

CHAPTER

71

POWER PLANT



CHAPTER 71
POWER PLANT

CH-SC-SU	Schem	Page	Sheet	Date	CH-SC-SU	Schem	Page	Sheet	Date
71-EFFECTIVE PAGES									
		1		May 06/2009					
		2		BLANK					
71-CONTENTS									
R		1		May 06/2009					
		2		BLANK					
71-ALPHABETICAL INDEX									
		1		Dec 18/2007					
O		2		BLANK					
	71-00-00								
R		101		May 06/2009					
D		102		May 06/2009					

A = Added, R = Revised, D = Deleted, O = Overflow

71-EFFECTIVE PAGES

CHAPTER 71
POWER PLANT

Title	CH-SC-SU	Schem	Page	Sheet	Date	Effectivity
<u>POWER PLANT</u>						
POWER PLANT - GENERAL ARRANGEMENT	71-00-00		101		May 06/2009	ALL

CHAPTER 71
POWER PLANT

CH-SC-SU	Title
71-00-00	POWER PLANT - GENERAL ARRANGEMENT

CH-SC-SU	Title
----------	-------

71-ALPHABETICAL INDEX

D280N032S

5001

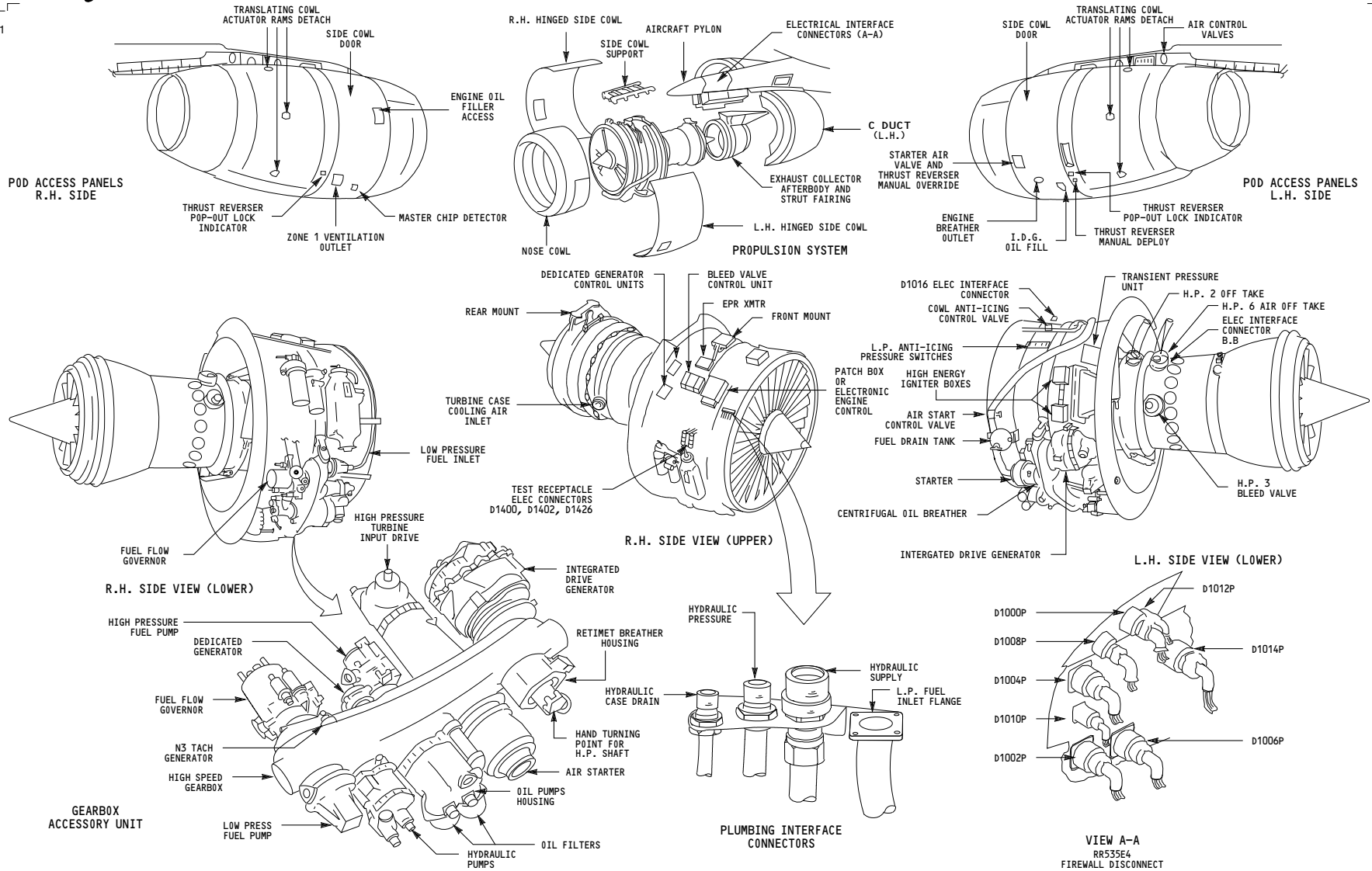

ALL	<p>POWER PLANT - GENERAL ARRANGEMENT</p> <p>D280N032S</p>
-----	--

71-00-00

Page 101

May 06/2009