

CHAPTER

74

IGNITION



CHAPTER 74
IGNITION

CH-SC-SU	Schem	Page	Sheet	Date	CH-SC-SU	Schem	Page	Sheet	Date
74-EFFECTIVE PAGES									
		1		Oct 09/2008					
		2		BLANK					
74-CONTENTS									
		1		Dec 18/2007					
		2		BLANK					
74-ALPHABETICAL INDEX									
		1		Dec 18/2007					
		2		BLANK					
74-31-01									
		101		Jan 21/2005					
		102		Jan 21/2005					
74-31-02									
		101		Jan 21/2005					
		102		Jan 21/2005					

A = Added, R = Revised, D = Deleted, O = Overflow

74-EFFECTIVE PAGES



CHAPTER 74
IGNITION

Title	CH-SC-SU	Schem	Page	Sheet	Date	Effectivity
<u>ENGINE IGNITION CONTROL</u>						
LEFT ENGINE IGNITION	74-31-01		101		Jan 21/2005	001-099
			102		Jan 21/2005	115-199
RIGHT ENGINE IGNITION	74-31-02		101		Jan 21/2005	001-099
			102		Jan 21/2005	115-199

CHAPTER 74
IGNITION

CH-SC-SU	Title
74-31-01	LEFT ENGINE IGNITION
74-31-02	RIGHT ENGINE IGNITION

CH-SC-SU	Title
----------	-------

74-ALPHABETICAL INDEX

-B
5014

WIRING DIAGRAMS
74-31-11

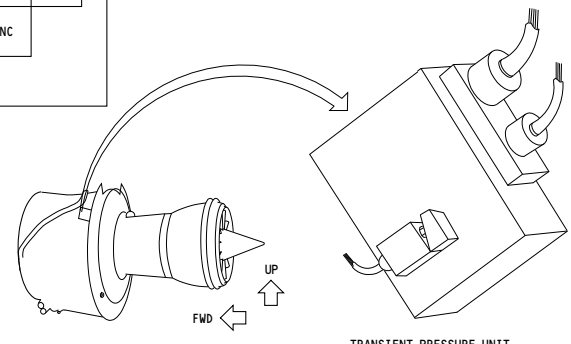
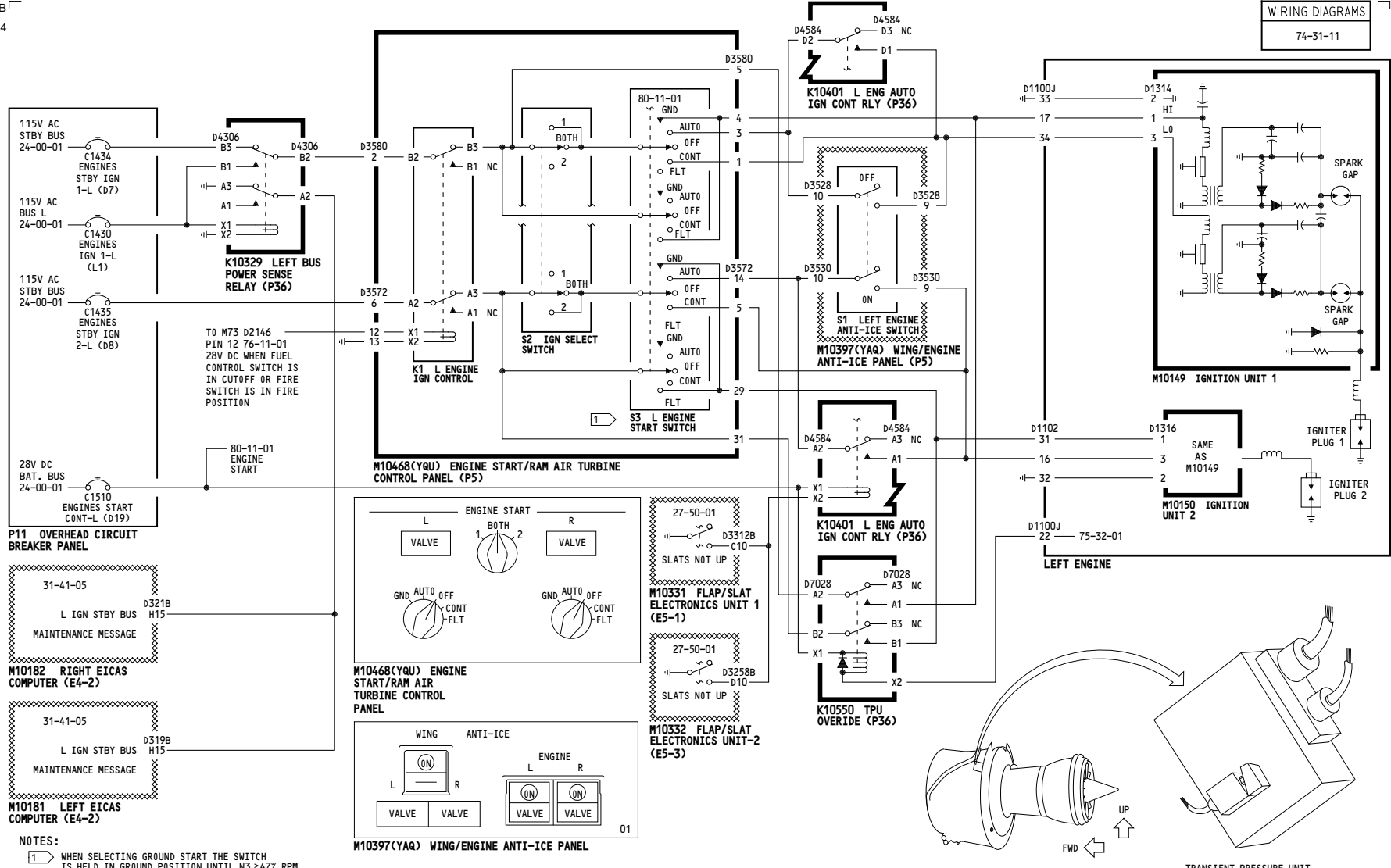

<p>001-099</p>	<p>LEFT ENGINE IGNITION</p> <p>D280N032S</p>
----------------	---

74-31-01

Page 101

Jan 21/2005

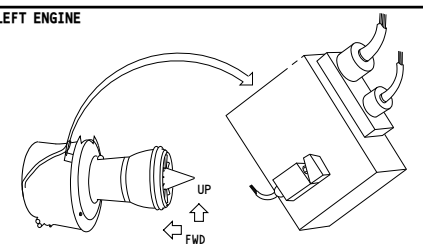
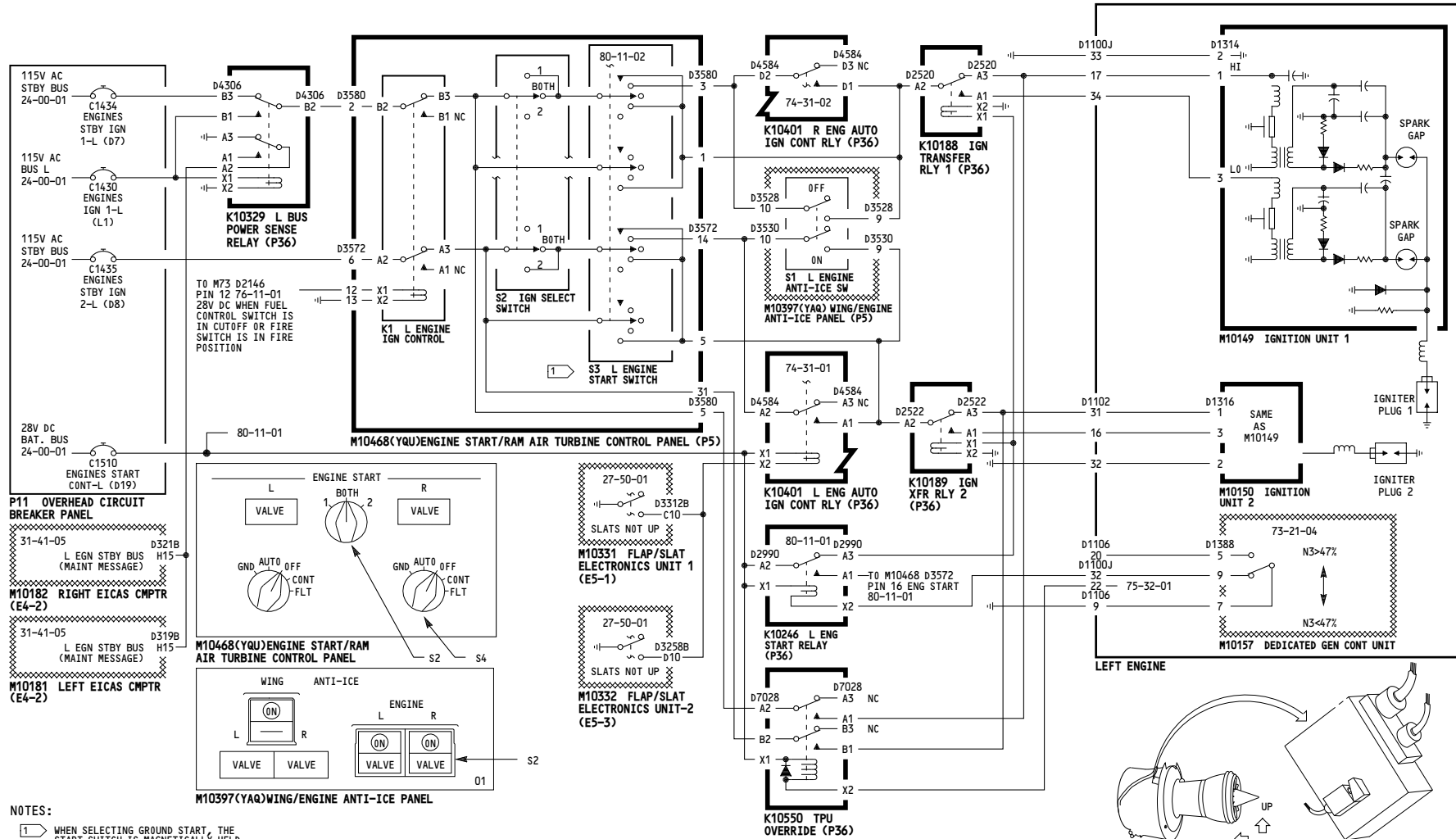

115-199	LEFT ENGINE IGNITION
D280N032S	

74-31-01

-B
5014

WIRING DIAGRAMS
74-31-21

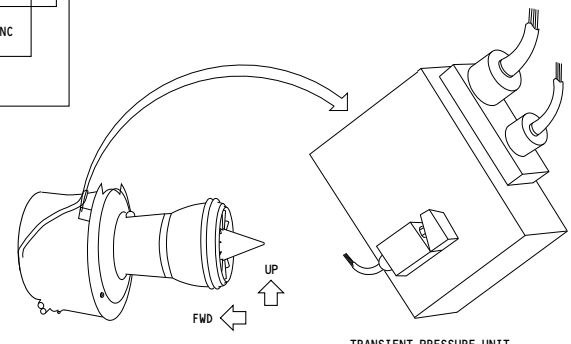
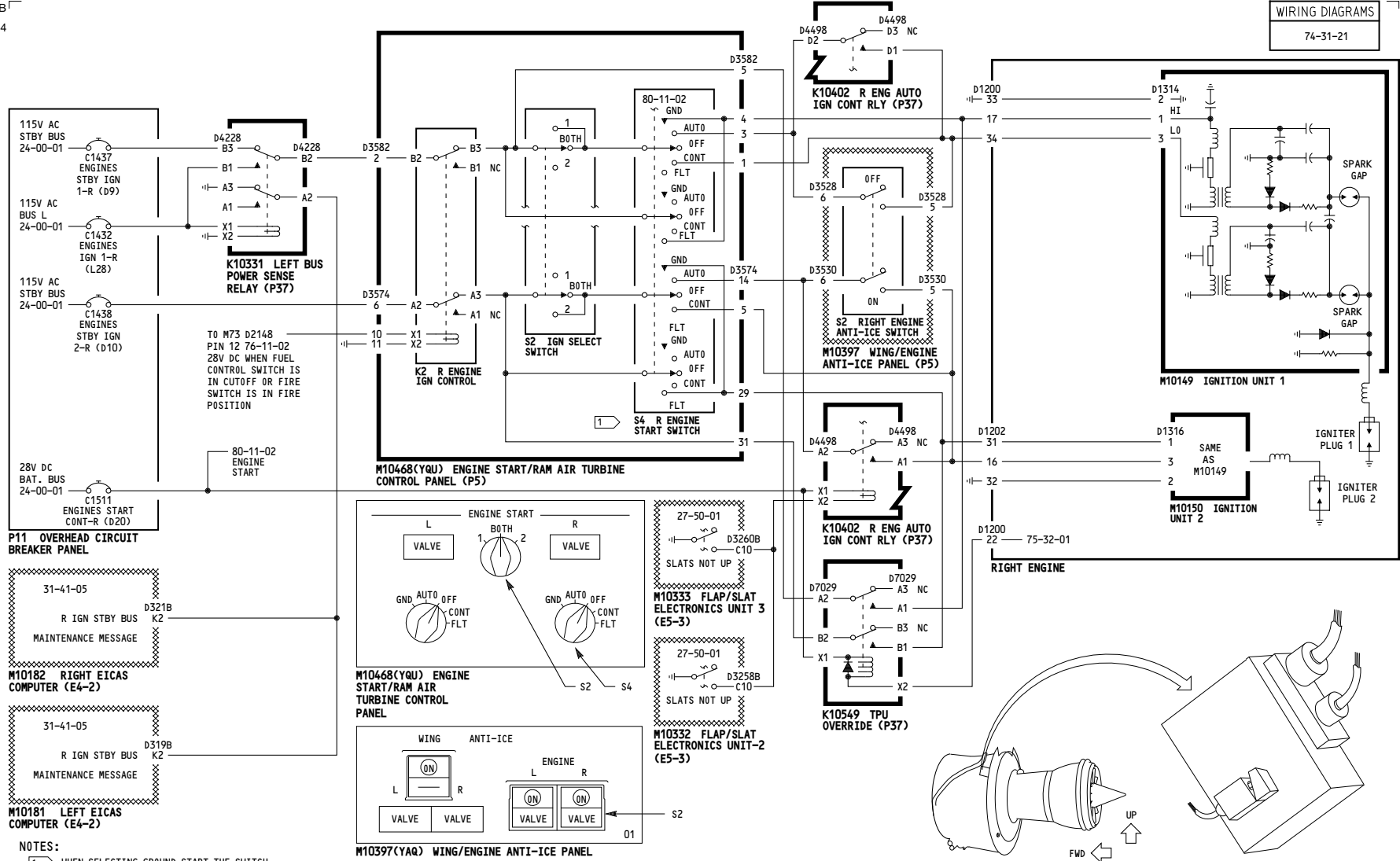

<p>001-099</p>	<p>RIGHT ENGINE IGNITION</p> <p>D280N032S</p>
----------------	--

74-31-02

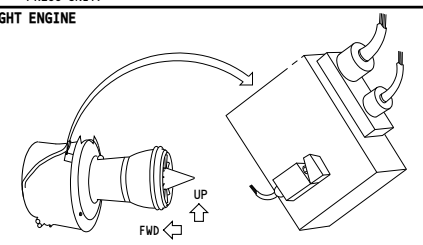
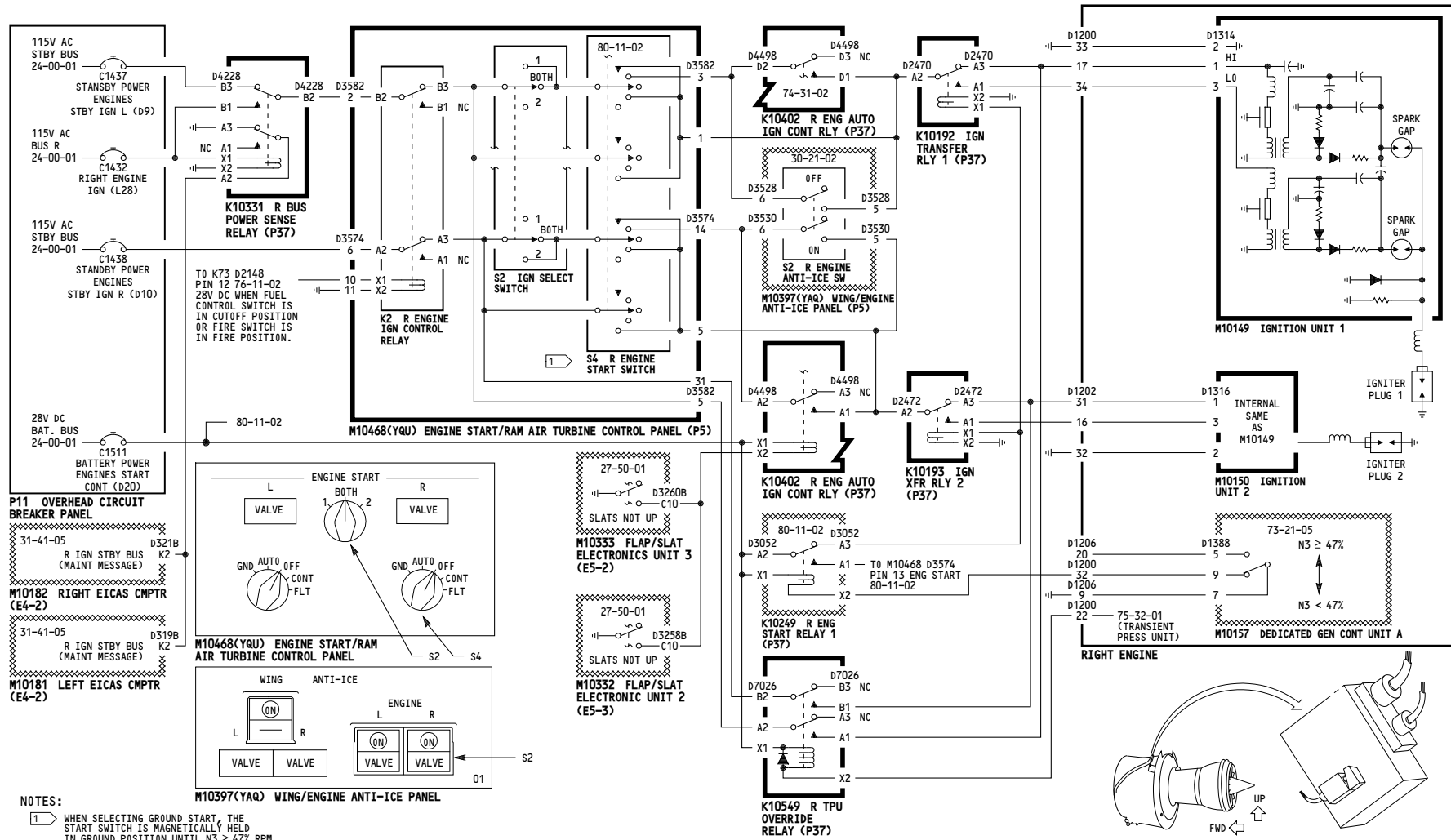

115-199	RIGHT ENGINE IGNITION
D280N032S	

74-31-02