

**CHAPTER**

**79**

**OIL**



CHAPTER 79  
OIL

CH-SC-SU	Schem	Page	Sheet	Date	CH-SC-SU	Schem	Page	Sheet	Date
79-EFFECTIVE PAGES					79-35-01				
		1		May 06/2009	R		101		May 06/2009
		2		BLANK					
79-CONTENTS									
R		1		May 06/2009					
		2		BLANK					
79-ALPHABETICAL INDEX									
		1		Dec 18/2007					
		2		BLANK					
	79-00-00								
R		101		May 06/2009					
	79-21-00								
R		101		May 06/2009					
	79-31-01								
R		101		May 06/2009					
D		102		May 06/2009					
A		101.1		May 06/2009					
	79-32-01								
R		101		May 06/2009					
	79-33-01								
R		101		May 06/2009					
D		102		May 06/2009					
	79-34-01								
R		101		May 06/2009					

A = Added, R = Revised, D = Deleted, O = Overflow

**79-EFFECTIVE PAGES**

Page 1  
May 06/2009

D280N032S



CHAPTER 79  
OIL

Title	CH-SC-SU	Schem	Page	Sheet	Date	Effectivity
<b><u>OIL</u></b>						
I ENGINE OIL SYSTEM	79-00-00		101		May 06/2009	ALL
<b><u>ENGINE OIL DISTRIBUTION SYSTEM</u></b>						
I ENGINE OIL DISTRIBUTION SYSTEM	79-21-00		101		May 06/2009	ALL
<b><u>OIL QUANTITY INDICATING SYSTEM</u></b>						
I ENGINE OIL QUANTITY INDICATION	79-31-01		101		May 06/2009	ALL
I			101.1		May 06/2009	001
<b><u>OIL PRESSURE INDICATING SYSTEM</u></b>						
I ENGINE OIL PRESSURE INDICATION	79-32-01		101		May 06/2009	ALL
<b><u>LOW OIL PRESSURE WARNING SYSTEM</u></b>						
I ENGINE OIL LOW PRESSURE WARNING	79-33-01		101		May 06/2009	ALL
<b><u>OIL TEMPERATURE INDICATING SYSTEM</u></b>						
I ENGINE OIL TEMPERATURE INDICATION	79-34-01		101		May 06/2009	ALL
<b><u>OIL FILTER BYPASS WARNING SYSTEM</u></b>						
I ENGINE OIL FILTER BYPASS WARNING	79-35-01		101		May 06/2009	ALL

CHAPTER 79  
OIL

CH-SC-SU	Title
79-21-00	ENGINE OIL DISTRIBUTION SYSTEM
79-35-01	ENGINE OIL FILTER BYPASS WARNING
79-33-01	ENGINE OIL LOW PRESSURE WARNING
79-32-01	ENGINE OIL PRESSURE INDICATION
79-31-01	ENGINE OIL QUANTITY INDICATION
79-00-00	ENGINE OIL SYSTEM
79-34-01	ENGINE OIL TEMPERATURE INDICATION

CH-SC-SU	Title
----------	-------

**79-ALPHABETICAL INDEX**

5000

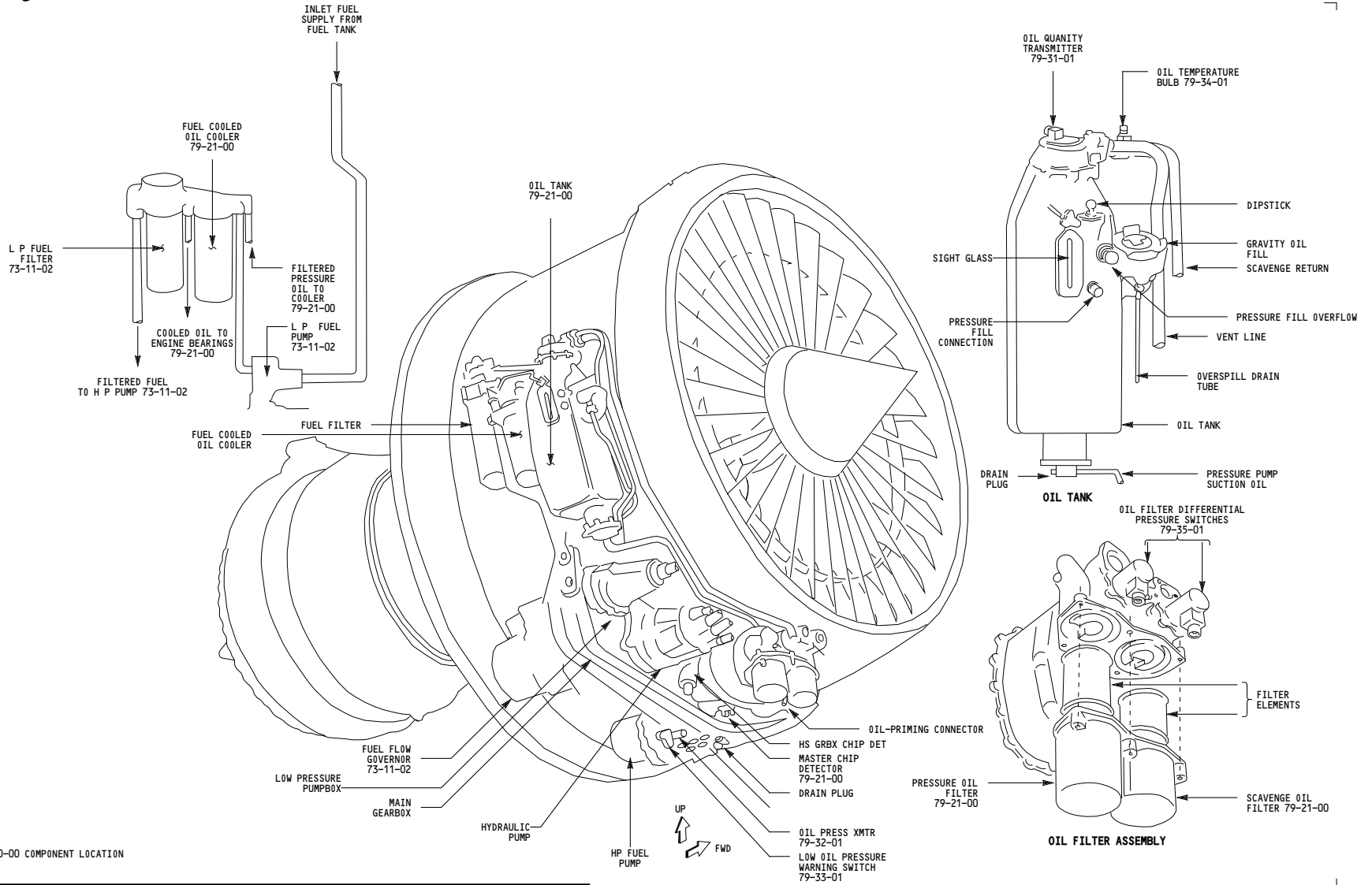

NOTE:  
SEE 71-00-00 COMPONENT LOCATION

ALL	<p align="center"><b>ENGINE OIL SYSTEM</b></p> <p align="center">D280N032S</p>
-----	--

**79-00-00**

Page 101

May 06/2009

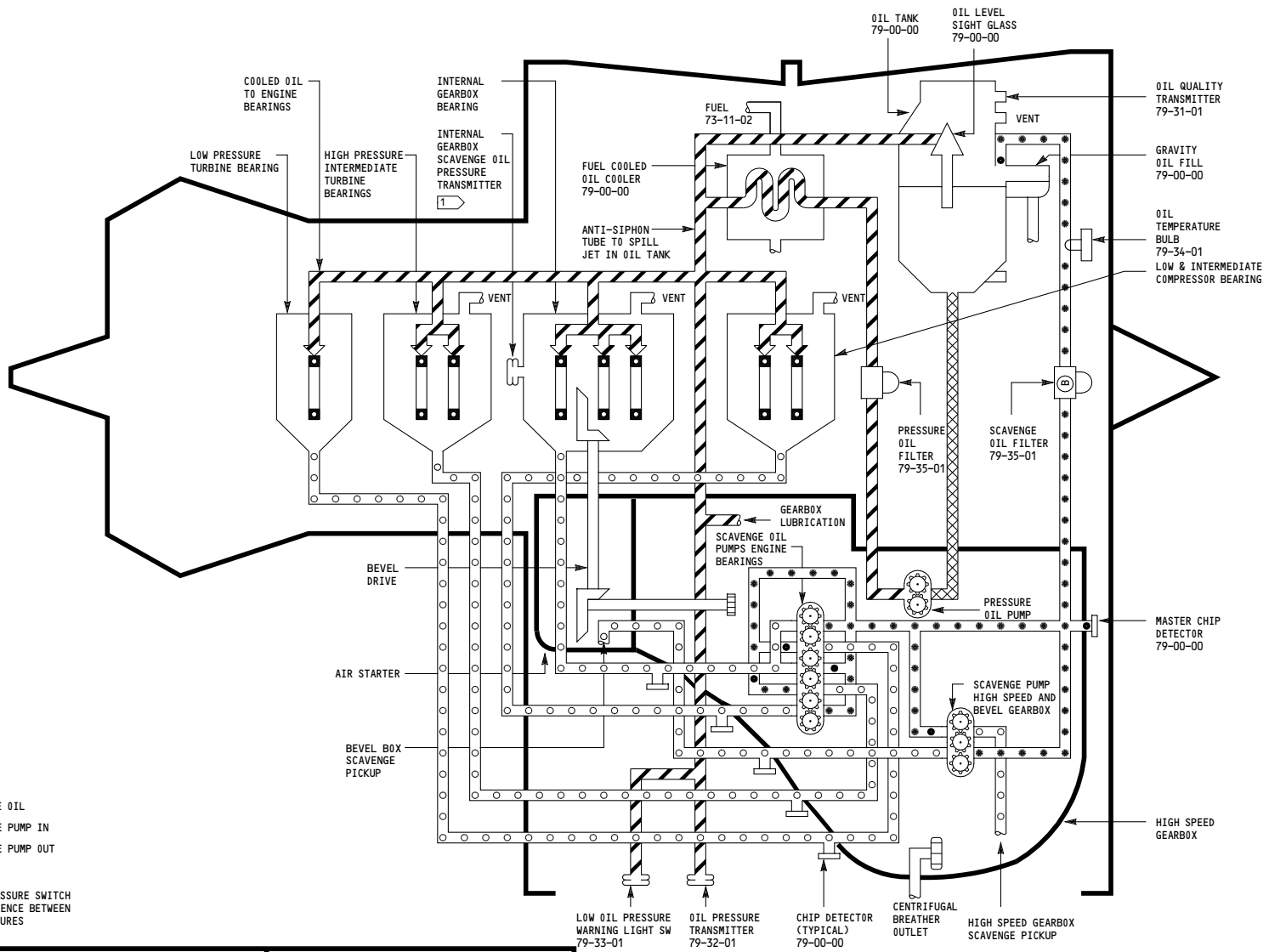

NOTES:

- PRESSURE OIL
- SCAVENGE PUMP IN
- SCAVENGE PUMP OUT
- SUPPLY
- LOW OIL PRESSURE SWITCH FROM DIFFERENCE BETWEEN THESE PRESSURES 79-32-01

ALL	<p><b>ENGINE OIL DISTRIBUTION SYSTEM</b></p> <p>D280N032S</p>
-----	---

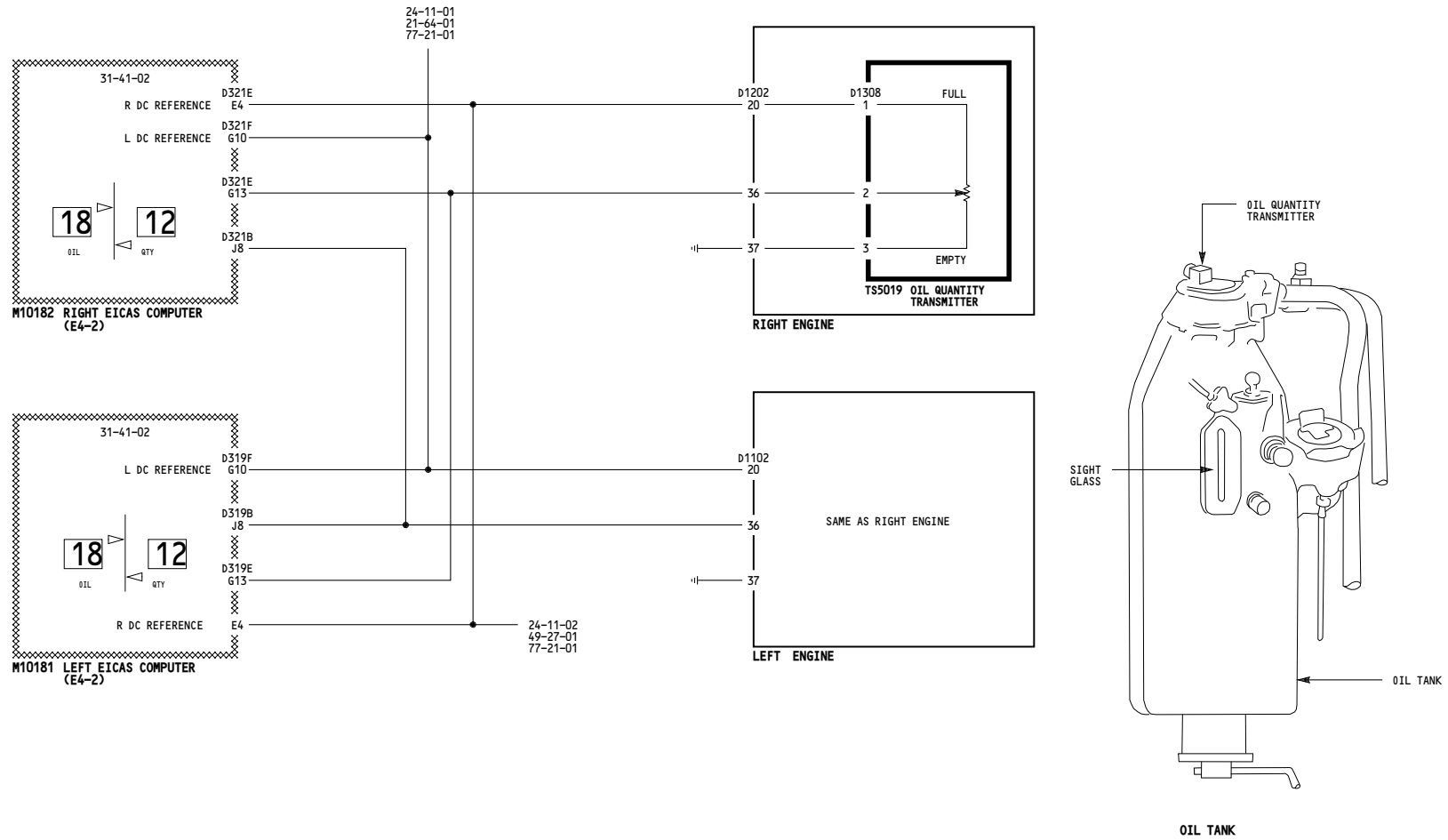

ALL	<p><b>ENGINE OIL QUANTITY INDICATION</b></p> <p>D280N032S</p>
-----	---

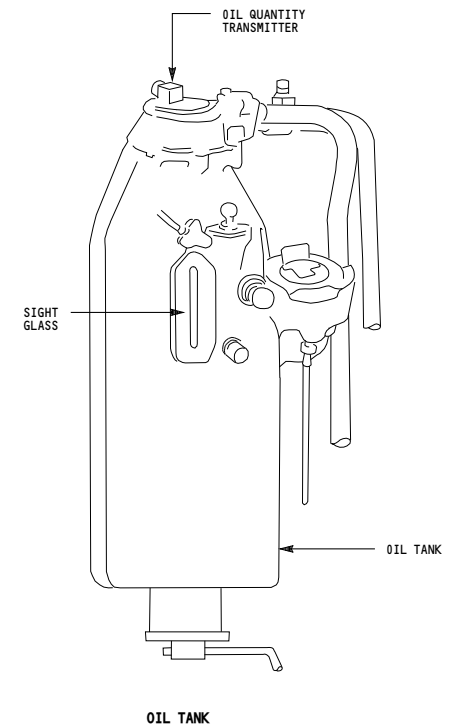
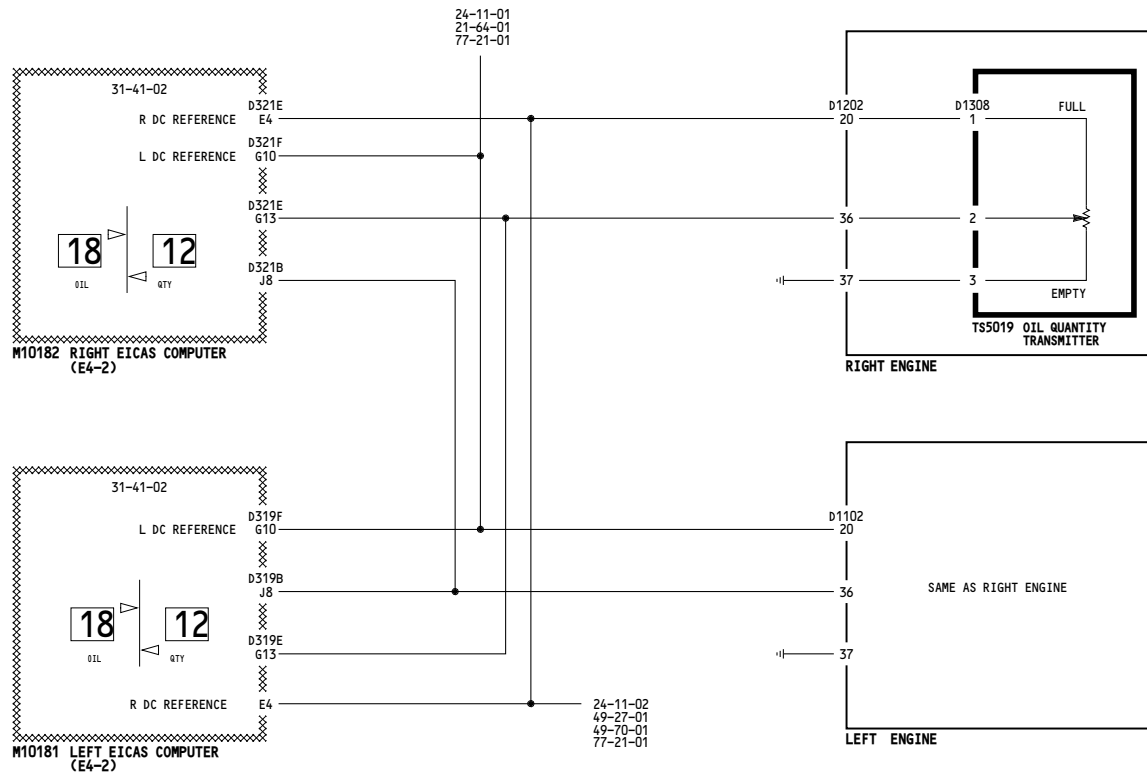

001	<p><b>ENGINE OIL QUANTITY INDICATION</b></p> <p>D280N032S</p>
-----	---

Incorporates  
31-0184 R02

**79-31-01**

Page 101.1

May 06/2009



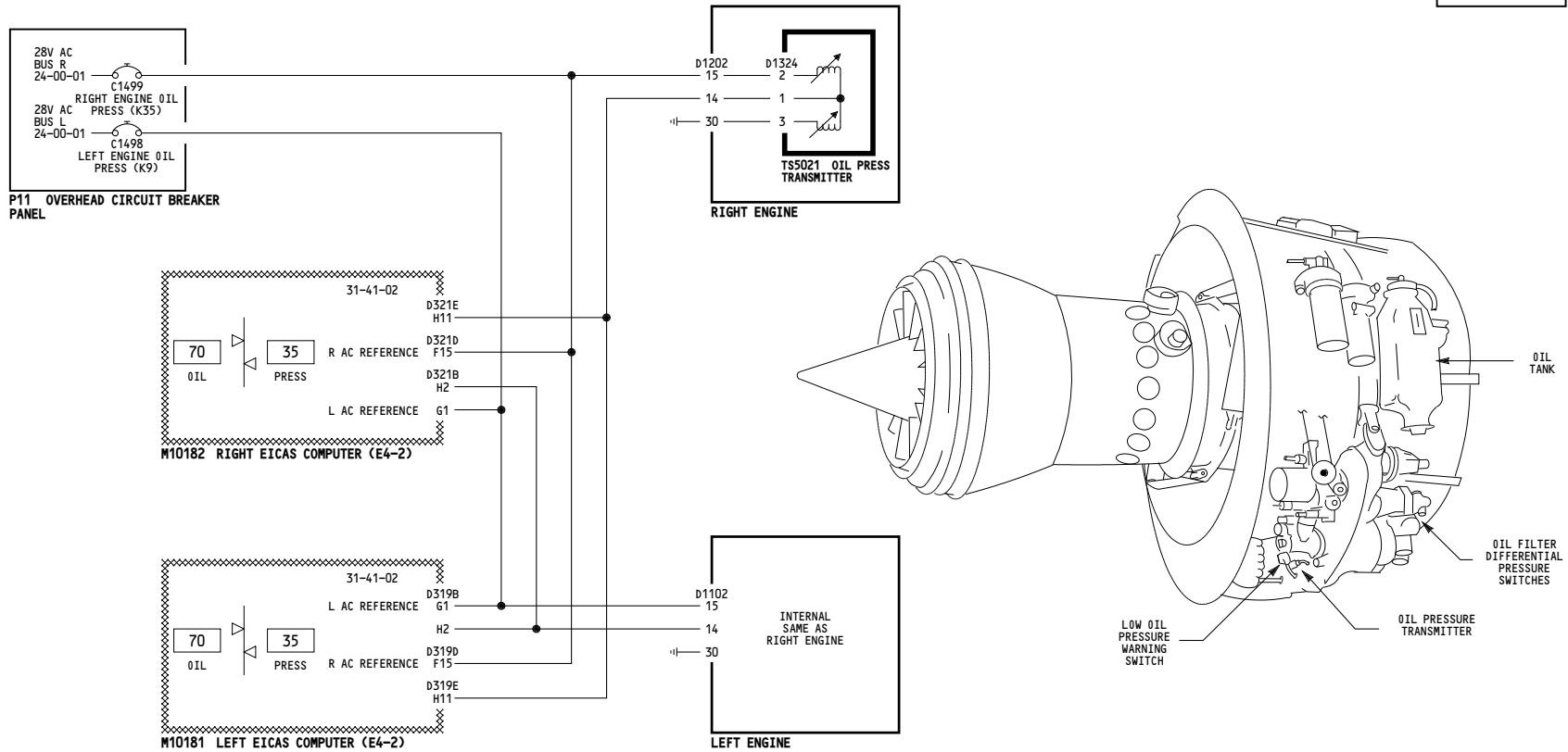

ALL	<b>ENGINE OIL PRESSURE INDICATION</b>
	D280N032S

-A  
5012

WIRING DIAGRAMS  
79-33-11

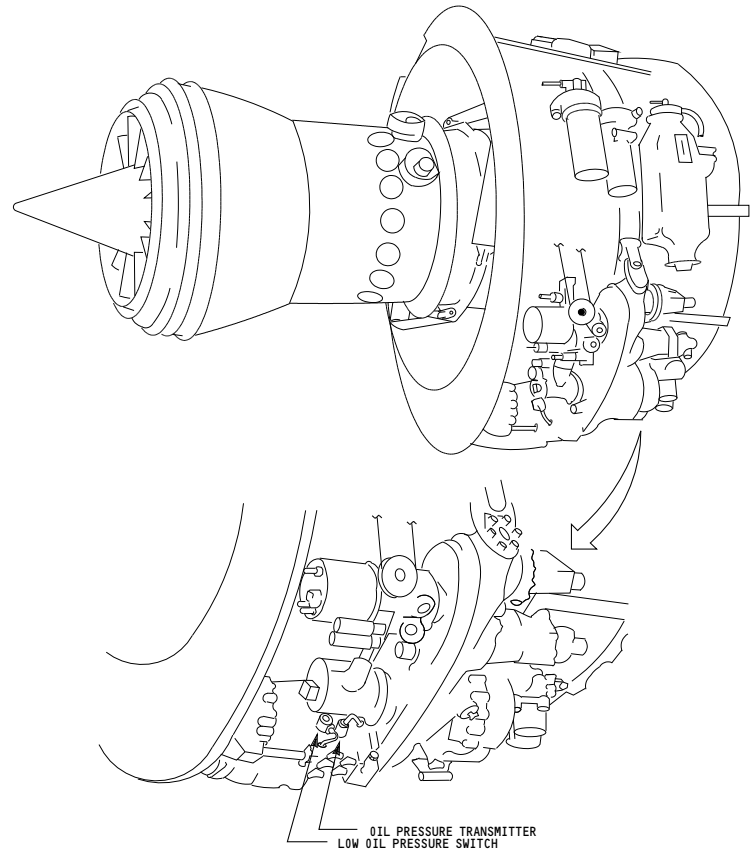
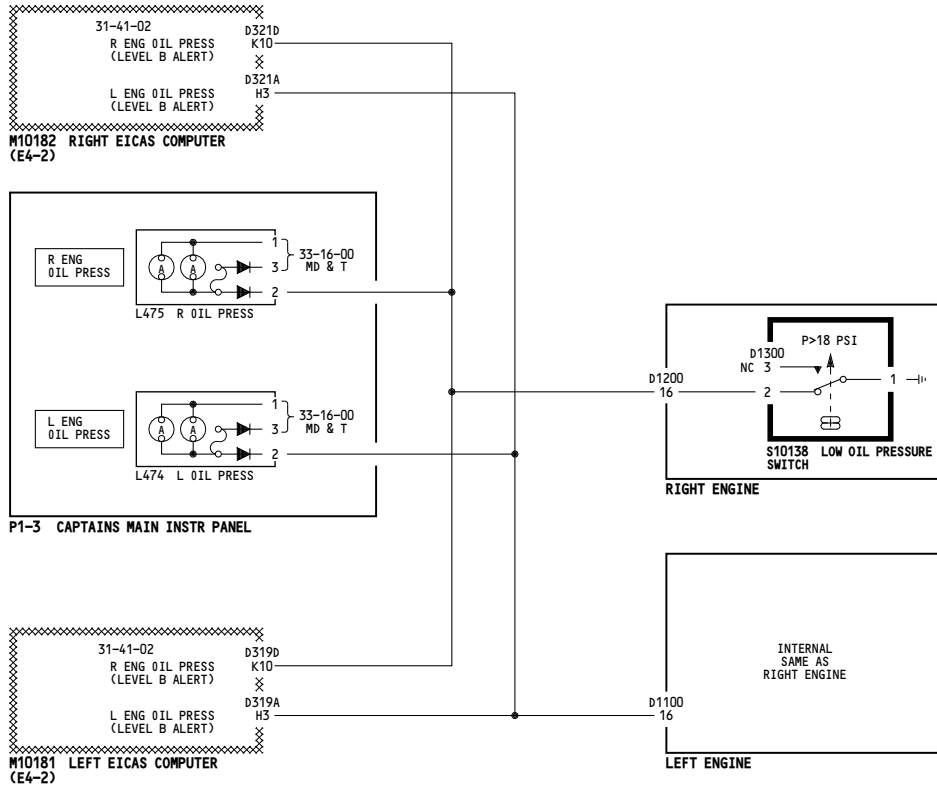

ALL	<p><b>ENGINE OIL LOW PRESSURE WARNING</b></p> <p>D280N032S</p>
-----	--

**79-33-01**

Page 101

May 06/2009

WIRING DIAGRAMS  
79-34-11

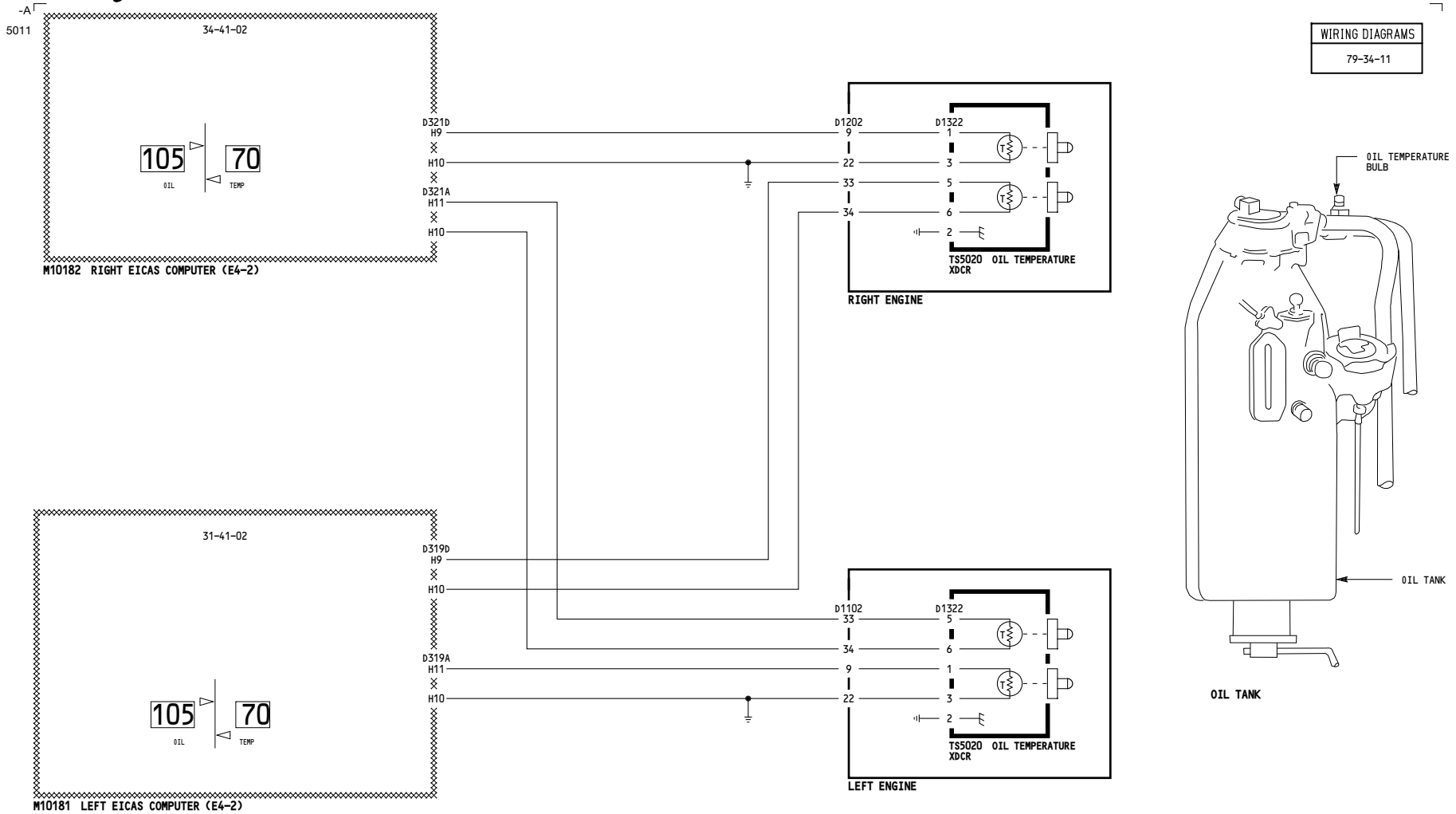

ALL	<p><b>ENGINE OIL TEMPERATURE INDICATION</b></p> <p>D280N032S</p>
-----	--

**79-34-01**

Page 101

May 06/2009

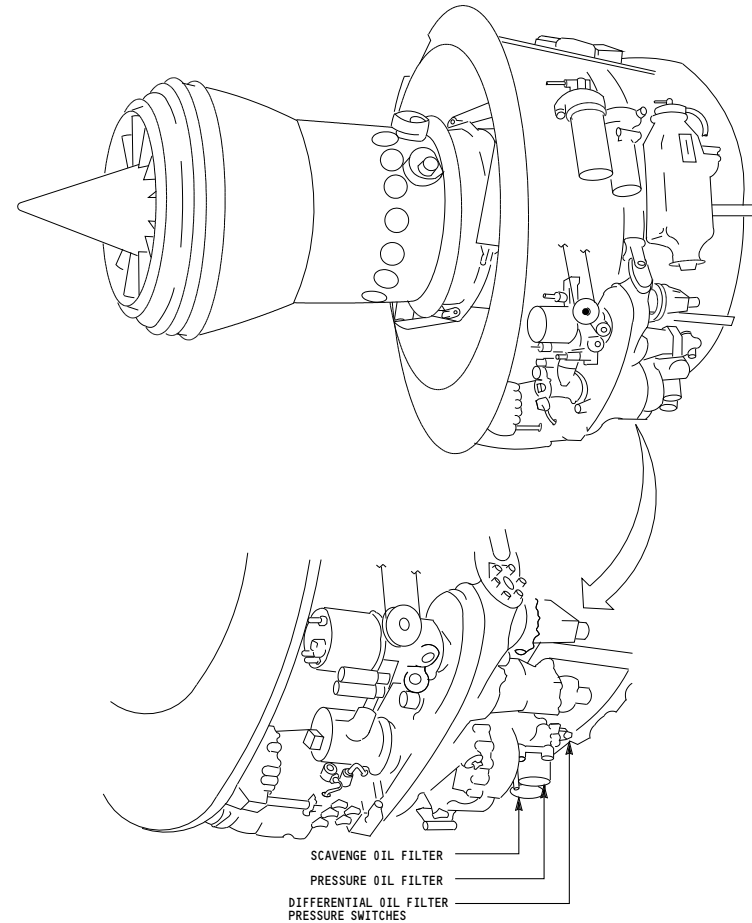
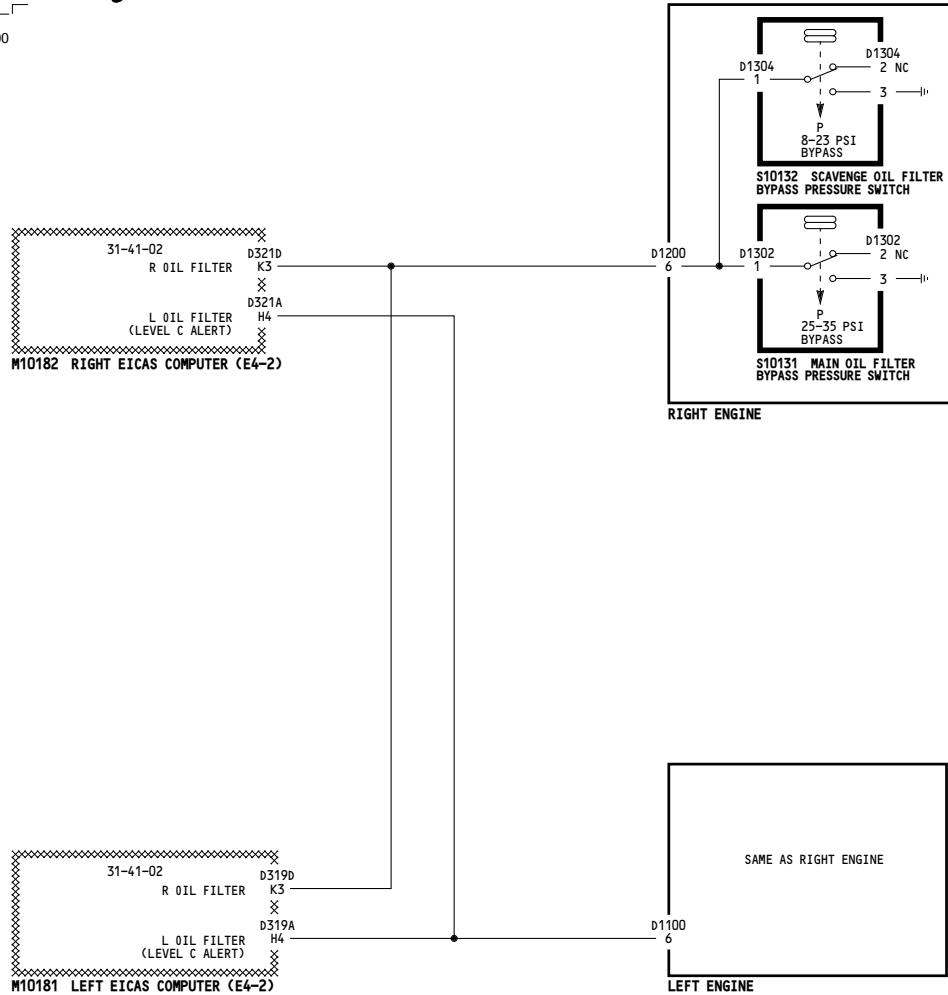

ALL	<b>ENGINE OIL FILTER BYPASS WARNING</b>
	D280N032S