

**CHAPTER**

**23**

**COMMUNICATIONS**



767

ILLUSTRATED TOOL AND EQUIPMENT MANUAL

CHAPTER 23  
COMMUNICATIONS

| Subject/Page    | Date        | Subject/Page | Date        | Subject/Page | Date |
|-----------------|-------------|--------------|-------------|--------------|------|
| EFFECTIVE PAGES |             | 23-40-07     |             |              |      |
| 1               | Apr 10/2008 | 1            | Oct 10/2006 |              |      |
| 2               | BLANK       | 2            | BLANK       |              |      |
| 23-CONTENTS     |             | 23-70-01     |             |              |      |
| O 1             | Apr 10/2008 | 1            | Apr 10/2006 |              |      |
| 2               | BLANK       | 2            | BLANK       |              |      |
| 23-10-01        |             | 23-70-02     |             |              |      |
| 1               | Oct 10/2006 | 1            | Oct 10/2007 |              |      |
| 2               | Oct 10/2006 | 2            | Apr 10/2007 |              |      |
| 23-10-02        |             | 3            | Apr 10/2007 |              |      |
| 1               | Apr 10/2006 | 4            | Apr 10/2007 |              |      |
| 2               | Apr 10/2006 |              |             |              |      |
| 23-20-01        |             |              |             |              |      |
| O 1             | Apr 10/2008 |              |             |              |      |
| 2               | Apr 10/2006 |              |             |              |      |
| 23-30-01        |             |              |             |              |      |
| 1               | Oct 10/2007 |              |             |              |      |
| 2               | Oct 10/2006 |              |             |              |      |
| 23-40-01        |             |              |             |              |      |
| 1               | Oct 10/2006 |              |             |              |      |
| 2               | Oct 10/2006 |              |             |              |      |
| 23-40-02        |             |              |             |              |      |
| 1               | Oct 10/2006 |              |             |              |      |
| 2               | Oct 10/2006 |              |             |              |      |
| 23-40-03        |             |              |             |              |      |
| 1               | Oct 10/2006 |              |             |              |      |
| 2               | Apr 10/2006 |              |             |              |      |
| 3               | Apr 10/2006 |              |             |              |      |
| 4               | BLANK       |              |             |              |      |
| 23-40-04        |             |              |             |              |      |
| 1               | Oct 10/2006 |              |             |              |      |
| 2               | Apr 10/2006 |              |             |              |      |
| 3               | Apr 10/2006 |              |             |              |      |
| 4               | BLANK       |              |             |              |      |
| 23-40-05        |             |              |             |              |      |
| 1               | Oct 10/2006 |              |             |              |      |
| 2               | Apr 10/2006 |              |             |              |      |
| 23-40-06        |             |              |             |              |      |
| 1               | Oct 10/2006 |              |             |              |      |
| 2               | Oct 10/2006 |              |             |              |      |

A = Added, R = Revised, O = Overflow, D = Deleted

# 23-EFFECTIVE PAGES



767

## ILLUSTRATED TOOL AND EQUIPMENT MANUAL

### TABLE OF CONTENTS

| <u>Subject</u> | <u>Title</u>  | <u>Part No.</u>             |
|----------------|---|-----------------------------|
| <b>23-</b>     | <b>COMMUNICATIONS</b>   |                             |
| 23-10-01       | TEST BOX - POWER SUPPLY, AUDIO ACCESSORY UNIT                     | A23011-1                    |
| 23-10-02       | TEST BOX - RADIO COMMUNICATIONS PANEL (RCP)<br>PROCESSOR CARD     | G23001-37, -41              |
| 23-20-01       | HOIST ADAPTER - SATCOM TOP - MOUNTED HIGH GAIN<br>ANTENNA         | J23001-1, -12               |
| 23-30-01       | TEST BOX ASSEMBLY - TV ANTENNA COUPLER                            | A23002-1, -14               |
| 23-40-01       | ACOUSTIC COUPLER - ATTENDANT'S HANDSET                            | A23001-1, -4, -8, -9        |
| 23-40-02       | TEST BOX - FLIGHT ATTENDANT INTERPHONE                            | A23004-1                    |
| 23-40-03       | TEST BOX - PRINTED CIRCUIT CARDS, AUDIO ACCESSORY<br>UNIT         | A23003-29, -30, -41,<br>-42 |
| 23-40-04       | TEST BOX - AUDIO SELECTOR PANEL                                   | A23009-20, -31              |
| 23-40-05       | TEST BOX - AUDIO ACCESSORY UNIT                                   | A23006-45, -46, -47         |
| 23-40-06       | EXTENDER BOARD - AUDIO ACCESSORY UNIT ASSEMBLY                    | B23001-1                    |
| 23-40-07       | ACOUSTIC COUPLER EQUIPMENT - TRANSMITTER AND<br>RECEIVER ASSEMBLY | C23002-1                    |
| 23-70-01       | PINGLITE  | PL1                         |
| 23-70-02       | SPANNER WRENCH  | 810-325                     |

# 23-CONTENTS

## ILLUSTRATED TOOL AND EQUIPMENT MANUAL

PART NUMBER: A23011-1**NAME:** TEST BOX - POWER SUPPLY, AUDIO ACCESSORY UNIT**AIRPLANE MAINTENANCE:** NO**COMPONENT MAINTENANCE:** YES**USAGE & DESCRIPTION:** The A23011 drawing has been transferred to BAE Systems and will no longer be revised by Boeing. The A23011 inclusion in the 767 ITEM is for information and historical purposes only.

This tool is used to test the Audio Accessory Unit power supply assembly. This tool is used on airplanes that have 285T0001-xx series Audio Accessory Unit. This tool is not used on airplanes that have 285T0001-2xx and on series Audio Accessory Unit. This tool is used on airplanes from line number 1 through 796 except the 767 freighter, 767-400 and those airplanes incorporating the provisions of PRR B13023. Refer to CMM 23-42-60 for further usage instructions.

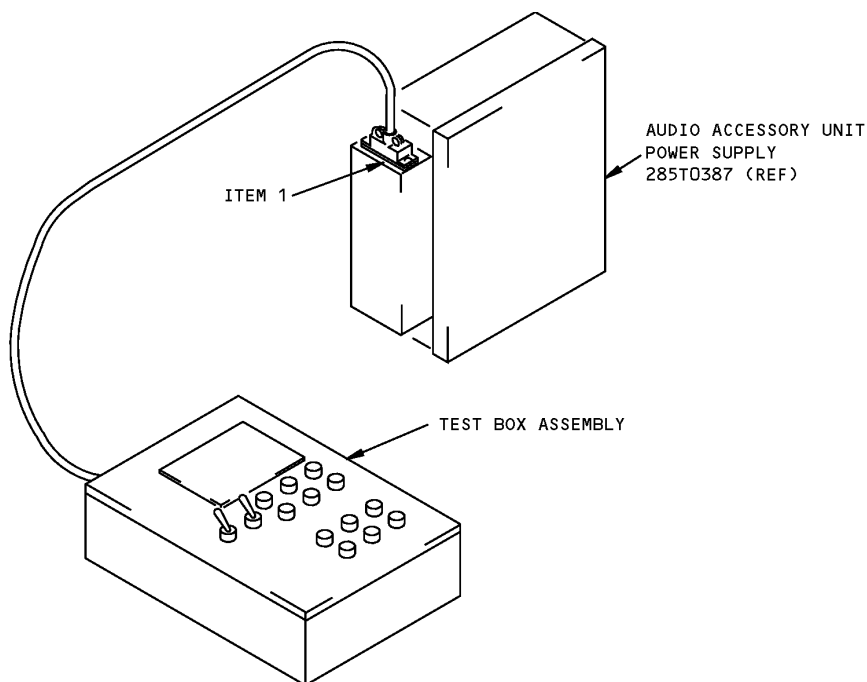
**WEIGHT:** 2 lbs (0.9 kg)**DIMENSIONS:** 2 x 7 x 9 inches (51 x 178 x 229 mm)

**Audio Accessory Power Supply Unit Test Box  
Figure 1**



767

ILLUSTRATED TOOL AND EQUIPMENT MANUAL

| REPAIRABLE/REPLACEABLE PARTS |          |              |             |
|------------------------------|----------|--------------|-------------|
| ITEM NO.                     | PART NO. | NOMENCLATURE | VENDOR CODE |
| 1                            | DE-9P    | CONNECTOR    | V71468      |

ILLUSTRATED TOOL AND EQUIPMENT MANUAL

**PART NUMBER: G23001-37, -41**

**NAME:** TEST BOX - RADIO COMMUNICATIONS PANEL (RCP) PROCESSOR CARD

**AIRPLANE MAINTENANCE:** NO

**COMPONENT MAINTENANCE:** YES

**USAGE & DESCRIPTION:** G23001-37 or -41 are used on all 767 airplanes. G23001-37 is used on airplanes equipped with an RCP processor card of 285U0038-33 or Or below. G23001-41 is used on airplanes equipped with an RCP processor card of 285U0038-38 or -39 only. Both G23001-37 and -41 are breakout boxes used to troubleshoot and test the radio panel communication processor. Refer to CMM 23-11-21 for complete usage instructions.

**WEIGHT:** G23001-37 - 5 lbs (2.3 kg)  
G23001-41 - 8 lbs (3.6 kg)

**DIMENSIONS:** G23001-37 - 5 x 13 x 17 inches (127 x 330 x 432 mm)  
G23001-41 - 5 x 17 x 22 inches (127 x 432 x 559 mm)

**NOTE:** G23001-37 supersedes G23001-32.

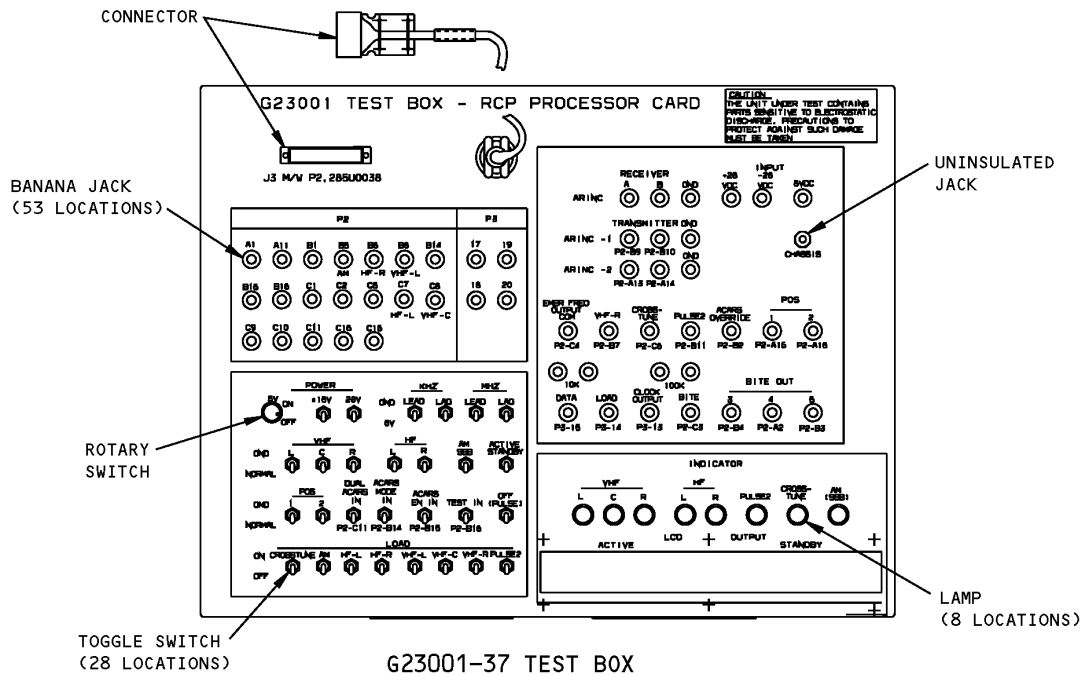

**RCP Processor Card Test Box - G23001-37**  
**Figure 1**

**767**  
**ILLUSTRATED TOOL AND EQUIPMENT MANUAL**

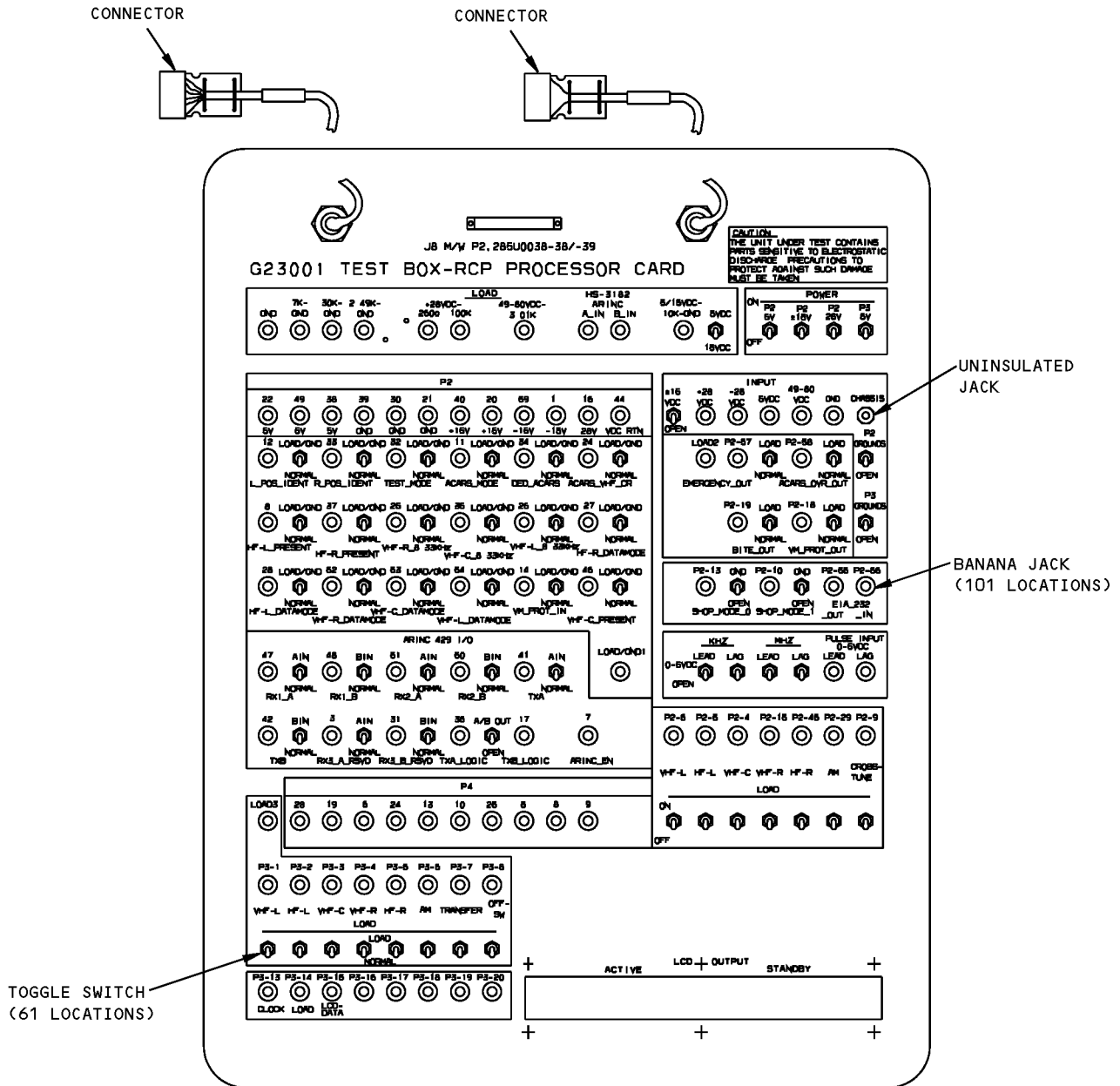

G23001-41 TEST BOX

**RCP Processor Card Test Box - G23001-41**  
**Figure 2**



767

## ILLUSTRATED TOOL AND EQUIPMENT MANUAL

PART NUMBER: J23001-1, -12

**NAME:** HOIST ADAPTER - SATCOM TOP - MOUNTED HIGH GAIN ANTENNA

**AIRPLANE MAINTENANCE:** YES

**COMPONENT MAINTENANCE:** NO

**USAGE & DESCRIPTION:** The J23001-1 or -12 tool is used to lift the SATCOM - High Gain Antenna during installation and maintenance for all 767 airplanes except the 767-200SF & -300BCF. Refer to Airplane Maintenance Manual 23-25-18 for complete usage instructions. These tools consist of a sling assembly and a storage box assembly.

**WEIGHT:** 3 lbs (1.4 kg)

**DIMENSIONS:** 6 x 6.5 x 9.5 inches (152 x 165 x 241 mm)

**NOTE:** J23001-12 replaces J23001-1 for future procurement.



**767  
ILLUSTRATED TOOL AND EQUIPMENT MANUAL**

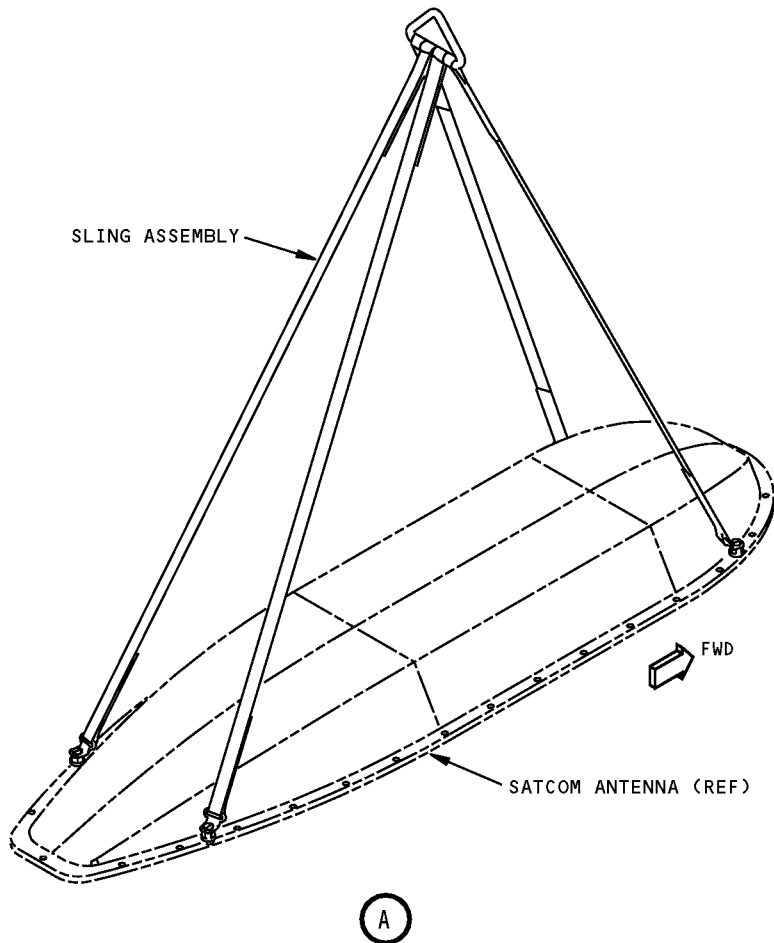
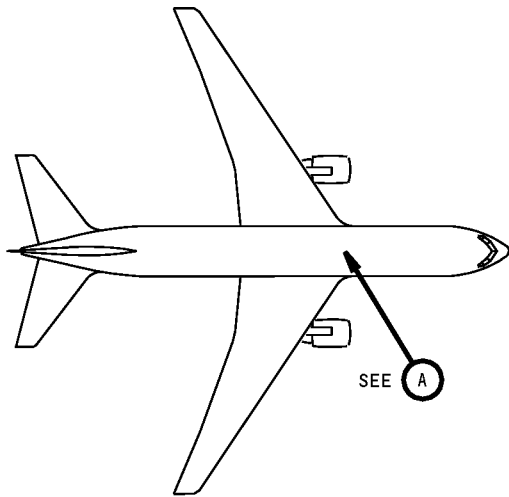

**Satcom Top-Mounted High Gain Antenna Hoist Adapter  
Figure 1**

## ILLUSTRATED TOOL AND EQUIPMENT MANUAL

**PART NUMBER: A23002-1, -14****NAME:** TEST BOX ASSEMBLY - TV ANTENNA COUPLER**AIRPLANE MAINTENANCE:** NO**COMPONENT MAINTENANCE:** YES**USAGE & DESCRIPTION:** The A23002 drawing has been transferred to BAE Systems and will no longer be revised by Boeing. The A23002 inclusion in the 767 ITEM is for information and historical purposes only.

This test equipment is connected to the J1 connector of the TV antenna coupler module assembly (M820) and is used to assist in measurement of both DC and RF parameters per Component Maintenance Manual 23-32-51. This tool is used on all 767 model airplanes except the 767 freighter.

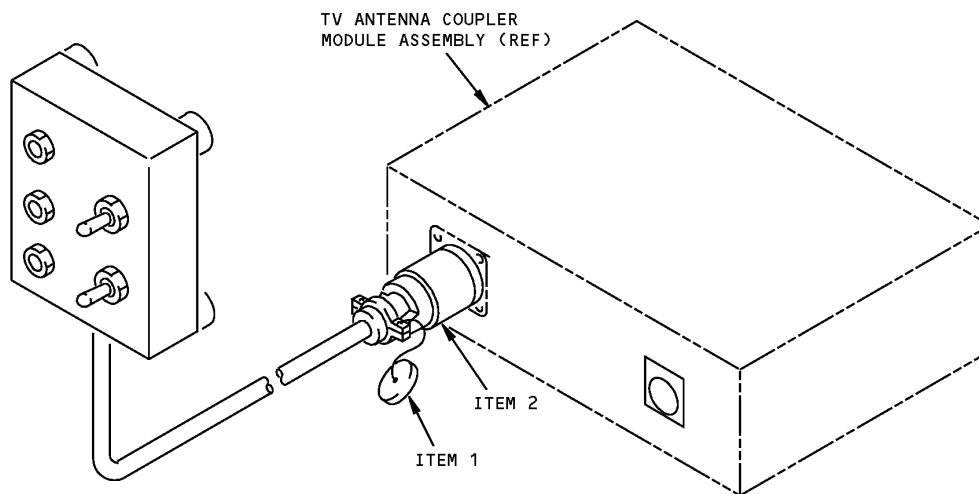
**WEIGHT:** 5 lbs (2.3 kg)**DIMENSIONS:** 4 x 9 x 12 inches (102 x 229 x 305 mm)**NOTE:** A23002-14 replaces A23002-1 for future procurement.

**TV Antenna Coupler Test Box Assembly  
Figure 1**



767

ILLUSTRATED TOOL AND EQUIPMENT MANUAL

| REPAIRABLE/REPLACEABLE PARTS |                 |              |             |
|------------------------------|-----------------|--------------|-------------|
| ITEM NO.                     | PART NO.        | NOMENCLATURE | VENDOR CODE |
| 1                            | M83723/59-110AC | CAP          |             |
| 2                            | M83723/86R105N  | CONNECTOR    |             |



767

## ILLUSTRATED TOOL AND EQUIPMENT MANUAL

**PART NUMBER: A23001-1, -4, -8, -9**

**NAME:** ACOUSTIC COUPLER - ATTENDANT'S HANDSET

**AIRPLANE MAINTENANCE:** NO

**COMPONENT MAINTENANCE:** YES

**USAGE & DESCRIPTION:** The A23001 drawing has been transferred to BAE Systems and will no longer be revised by Boeing. The A23001 inclusion in the 767 ITEM is for information and historical purposes only.

This tool is used in conjunction with A23004 flight attendant interphone test box to test 285T0038 interphone assembly per CMM 23-42-51, CMM 23-42-63 and 285N0412 per CMM 23-42-64. This tool is used on all 767 model airplanes except the 767 freighter. The -1 is used on 767s equipped with 285T0038 interphone assembly. The -1 and -4 are used on 767s equipped with genrad 1562-A audio signal generators. The -8 is used on 767s equipped with cirrus CRL-S11E audio signal generators. The -9 is used on 767s equipped with guest QC-20 audio signal generators. Also -4, -8, -9 are used on 767s equipped with 285N0412 handsets. The -1 consists of a -2 coupler. The -4 consists of a -5 coupler. The -8 consists of a -10 coupler. The -9 consists of a -11 coupler. All of -1, -4, -8 and -9 are stored in a -7 box assembly.

**WEIGHT:** 0.5 lb (0.2 kg)

**DIMENSIONS:** 1.5 x 2 x 4 inches (38 x 51 x 102 mm)

**ILLUSTRATED TOOL AND EQUIPMENT MANUAL**

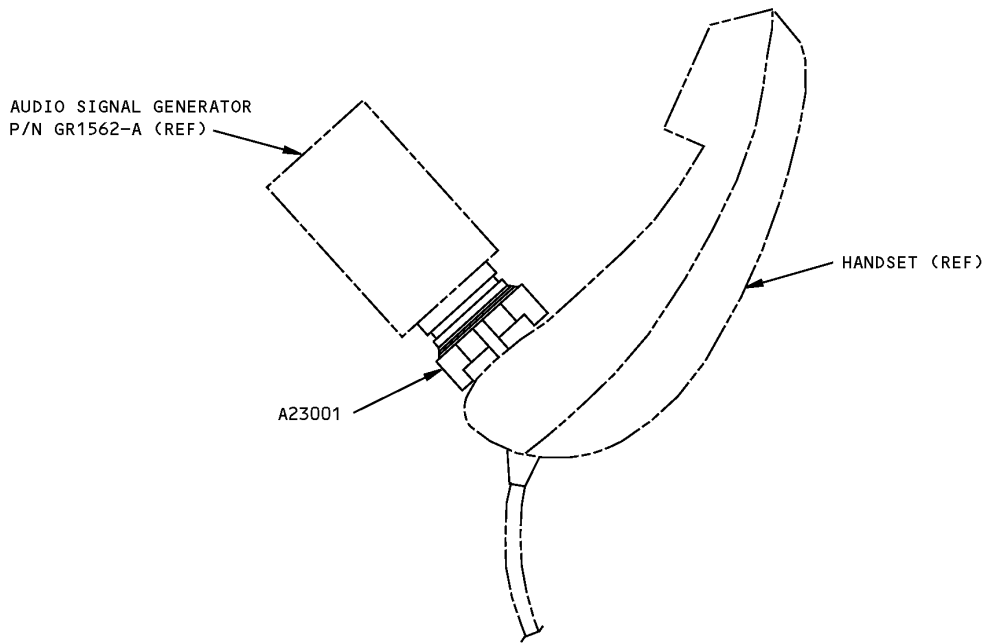

**Attendant's Handset Acoustic Coupler**  
**Figure 1**



767

## ILLUSTRATED TOOL AND EQUIPMENT MANUAL

**PART NUMBER: A23004-1**

**NAME:** TEST BOX - FLIGHT ATTENDANT INTERPHONE

**AIRPLANE MAINTENANCE:** NO

**COMPONENT MAINTENANCE:** YES

**USAGE & DESCRIPTION:** The A23004 drawing has been transferred to BAE Systems and will no longer be revised by Boeing. The A23004 inclusion in the 767 ITEM is for information and historical purposes only.

This test box is used to test the 285T0038 flight attendant interphone handset assembly per Component Maintenance Manual 23-42-51 and Component Maintenance Manual 23-42-63 and 285N0412 handset assembly per Component Maintenance Manual 23-42-64. This tool is used on all 767 model airplanes except the 767 freighter.

**WEIGHT:** 5 lbs (2.3 kg)

**DIMENSIONS:** 2 x 7 x 9 inches (51 x 178 x 229 kg)

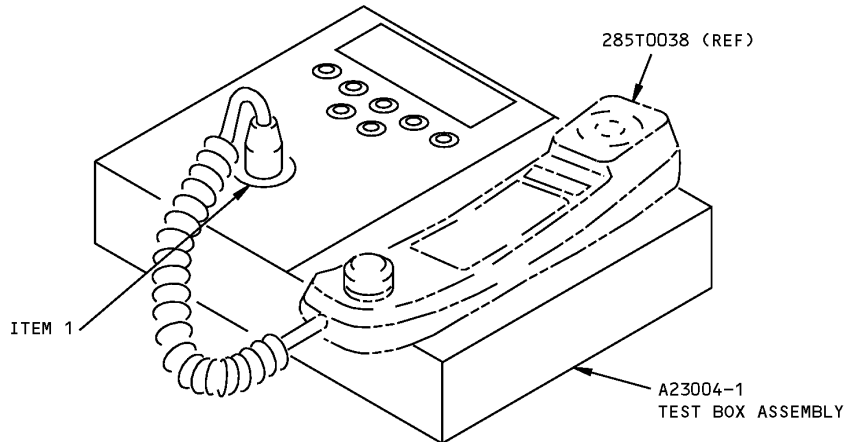

**Flight Attendant Interphone Test Box  
Figure 1**



767

ILLUSTRATED TOOL AND EQUIPMENT MANUAL

| REPAIRABLE/REPLACEABLE PARTS |          |              |             |
|------------------------------|----------|--------------|-------------|
| ITEM NO.                     | PART NO. | NOMENCLATURE | VENDOR CODE |
| 1                            | C5F      | CONNECTOR    | V82389      |



767

## ILLUSTRATED TOOL AND EQUIPMENT MANUAL

**PART NUMBER: A23003-29, -30, -41, -42**

**NAME:** TEST BOX - PRINTED CIRCUIT CARDS, AUDIO ACCESSORY UNIT

**AIRPLANE MAINTENANCE:** NO

**COMPONENT MAINTENANCE:** YES

**USAGE & DESCRIPTION:** The A23003 drawing has been transferred to BAE Systems and will no longer be revised by Boeing. The A23003 inclusion in the 767 ITEM is for information and historical purposes only.

A23003-29, -30, -40 and -41 used to perform functional tests on the interphone amplifier, main logic input/output, dual handset interface, and call interface printed circuit cards (PCA) in the audio accessory unit. A23003-41 and -42 are preferred for future procurement. The A23003-29,-30,-41 and -42 test box is used on all 767 airplanes except 767-400, 767 freighters and any 767 airplanes built after line number 796. A23003-29 and -30 have limited usage when testing handset interface PCA (285T0133). Refer to CMM 23-42-56. A23003-29,-30 and -41 have limited usage when testing call interface PCA (285T0135-23). A23003-42 is used in conjunction with A23003-29,-40 or -41 as applicable, for testing 285T0001 PCA's. A23003-42 also tests the 285T0135-23 call interface PCA's. Refer to CMM 23-42-58. Refer to CMM 23-42-53, CMM 23-42-54, CMM 23-42-56 and CMM 23-42-57 for complete usage instructions.

**WEIGHT:** A23003-29, -30, -41 - 10 lbs (4.5 kg)  
A23003-42 - 4 lbs (1.8 kg)

**DIMENSIONS:** A23003-29 - 4 x 16 x 18 inches (102 x 406 x 457 mm)  
A23003-30 - 4 x 16 x 18 inches (102 x 406 x 457 mm)  
A23003-41 - 4 x 16 x 18 inches (102 x 406 x 457 mm)  
A23003-42 - 4 x 12 x 14 inches (102 x 305 x 356 mm)

**NOTE:** A23003-41 supersedes A23003-34.  
A23003-41 replaces A23003-29 and -30 for future procurement.





**767**  
**ILLUSTRATED TOOL AND EQUIPMENT MANUAL**

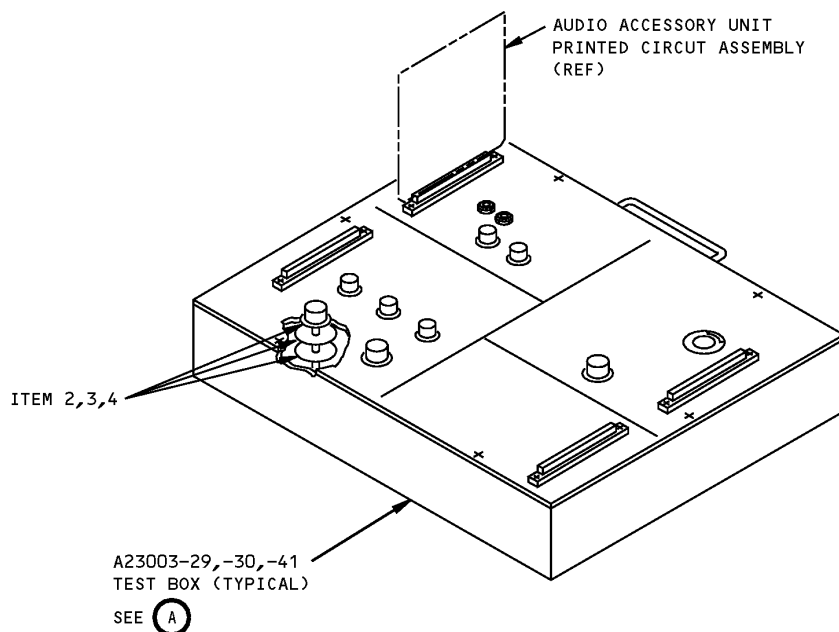

**Audio Accessory Unit Printed Circuit Cards Test Box**  
**Figure 2**

| <b>REPAIRABLE/REPLACEABLE PARTS</b> |                 |   |                    |
|-------------------------------------|-----------------|---|--------------------|
| <b>ITEM NO.</b>                     | <b>PART NO.</b> | <b>NOMENCLATURE</b>                     | <b>VENDOR CODE</b> |
| 1                                   | 389N-100K-S     | POTENTIOMETER                           | V12697             |
| 2                                   | 399174-AM       | ROTARY SWITCH SECTION                   | V76854             |
| 2                                   | D1D-0107        | ROTARY SWITCH SECTION (OPTIONAL)        | V79692             |
| 3                                   | 399117-AM       | ROTARY SWITCH SECTION                   | V76854             |
| 3                                   | D1D-0106        | ROTARY SWITCH SECTION (OPTIONAL)        | V79692             |
| 4                                   | 399257-A        | ROTARY SWITCH INDEX ASSEMBLY            | V76854             |
| 4                                   | D1-0108         | ROTARY SWITCH INDEX ASSEMBLY (OPTIONAL) | V79692             |
| 5                                   | D9G0223N        | ROTARY SWITCH                           | V79692             |
| 6                                   | D3C0111N        | ROTARY SWITCH                           | V79692             |
| 7                                   | 300052-001      | CONNECTOR                               | V03877             |



767

## ILLUSTRATED TOOL AND EQUIPMENT MANUAL

**PART NUMBER: A23009-20, -31**

**NAME:** TEST BOX - AUDIO SELECTOR PANEL

**AIRPLANE MAINTENANCE:** NO

**COMPONENT MAINTENANCE:** YES

**USAGE & DESCRIPTION:** The A23009 drawing has been transferred to BAE Systems and will no longer be revised by Boeing. The A23009 inclusion in the 767 ITEM is for information and historical purposes only.

A23009-20 or -31 are applicable to all 767 airplanes equipped with the 285T0022 audio selector panel. A23009-31 is a newer, simplified, smaller and lighter test box that is preferred for future procurement. A23009-20 has the same functionality. The A23009 tools are used to functionally test the 285T0022 audio selector panel and printed circuit assemblies 285T0226 and 285T0227. Refer to CMM 23-51-51, CMM 23-51-54 and 285T0226 per CMM 23-51-52 for usage instructions.

**WEIGHT:** A23009-20 - 10 lbs (4.5 kg)  
A23009-31 - 8 lbs (3.6 kg)

**DIMENSIONS:** A23009-20 - 6 x 15 x 18 inches (152 x 381 x 457 mm)  
A23009-31 - 4 x 10 x 17 inches (102 x 254 x 432 mm)

**NOTE:** A23009-31 supersedes A23009-25.  
A23009-31 replaces A23009-20 for future procurement.

**ILLUSTRATED TOOL AND EQUIPMENT MANUAL**

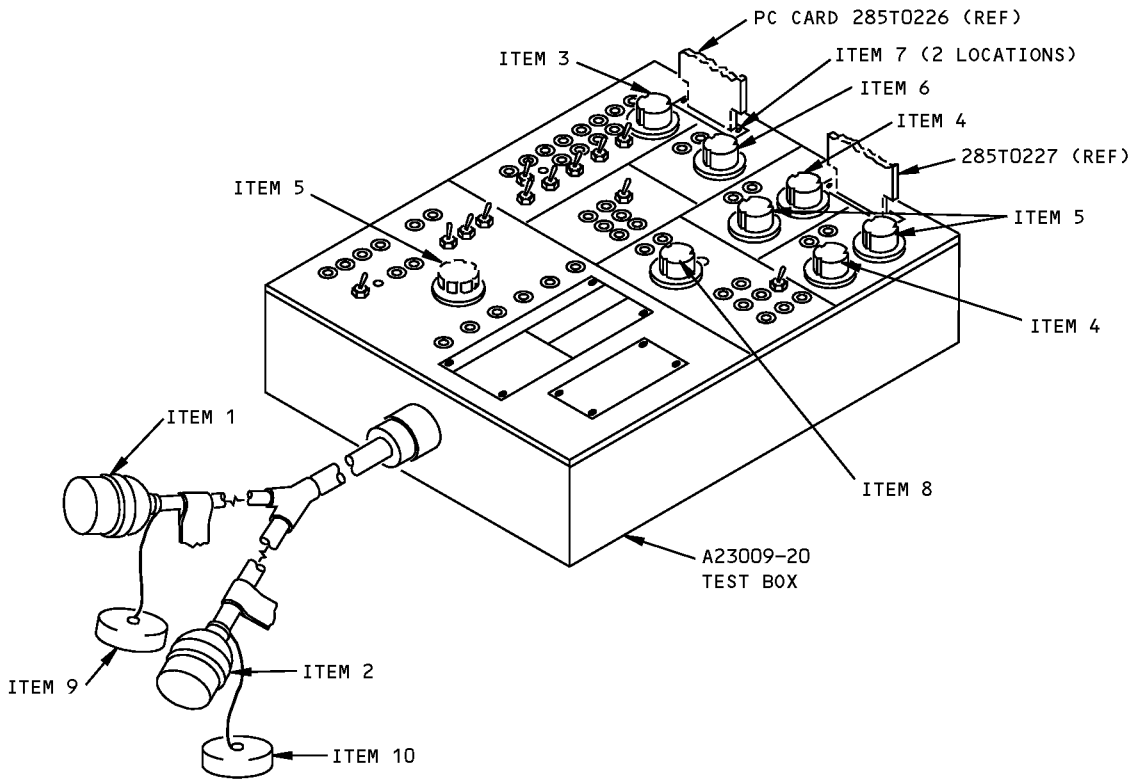

**Audio Selector Panel Test Box - A23009-20**  
**Figure 1**

ILLUSTRATED TOOL AND EQUIPMENT MANUAL

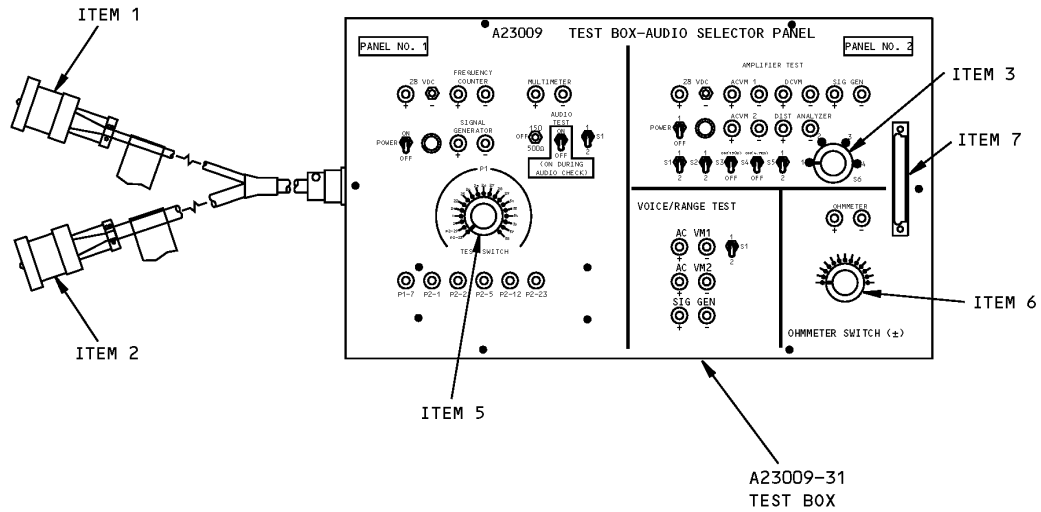

Audio Selector Panel Test Box - A23009-31  
Figure 2

| REPAIRABLE/REPLACEABLE PARTS |                 |              |             |
|------------------------------|-----------------|--------------|-------------|
| ITEM NO.                     | PART NO.        | NOMENCLATURE | VENDOR CODE |
| 1                            | MS24266R18B31SN | CONNECTOR    |             |
| 2                            | MS24266R20B41SN | CONNECTOR    |             |
| 3                            | 2550            | SWITCH       | V71950      |
| 4                            | PA-1001         | SWITCH       | V71950      |
| 5                            | PA-4001         | SWITCH       | V71950      |
| 6                            | PA-4003         | SWITCH       | V71950      |
| 7                            | 300055-003      | CONNECTOR    | V03877      |
| 8                            | PA-6019         | SWITCH       | V71950      |



767

## ILLUSTRATED TOOL AND EQUIPMENT MANUAL

**PART NUMBER: A23006-45, -46, -47**

**NAME:** TEST BOX - AUDIO ACCESSORY UNIT

**AIRPLANE MAINTENANCE:** NO

**COMPONENT MAINTENANCE:** YES

**USAGE & DESCRIPTION:** The A23006 drawing has been transferred to BAE Systems and will no longer be revised by Boeing. The A23006 inclusion in the 767 ITEM is for information and historical purposes only.

This tool is used to test Audio Accessory Unit 285T0001. This tool is used on airplanes that have 285T0001-xx series Audio Accessory Unit. This tool is not used on airplanes that have 285T0001-2xx and on series Audio Accessory Unit. This tool is used on airplanes from line number 1 through 796 except 767 freighter, 767-400 and those airplanes incorporating the provisions of PRR B13023. The -45 is used on all 767 airplanes except 767 airplanes listed above and airplanes equipped with 285T0001-46, 285T0001-69 and 285T0001-70 Audio Accessory Unit. The -46 is used on 767 airplanes equipped with 285T0001-46, 285T0001-69 and 285T0001-70 Audio Accessory Unit. The -47 is used on all 767 airplanes, except for the airplanes listed above. Refer to CMM 23-42-52 and CMM 23-42-61 for further usage instructions. Each of the -45, -46, -47 consists of a -19 board assembly, a -20 board assembly, two receptacle assemblies, two cup assemblies, related components and hardware. Also each of -46 and -47 includes a -18 switch assembly.

**WEIGHT:** 10 lbs (4.5 kg)

**DIMENSIONS:** 6 x 17 x 20 inches (152 x 432 x 508 mm)

**NOTE:** A23006-47 replaces A23006-45 and -46 for future procurement.  
A23006-47 supersedes A23006-39.  
A23006-39, -45, -46 supersede A23006-34, -26, -27 respectively.  
A23006-26, -27 supersede A23006-23, -22, -16, -1.

**767**  
**ILLUSTRATED TOOL AND EQUIPMENT MANUAL**

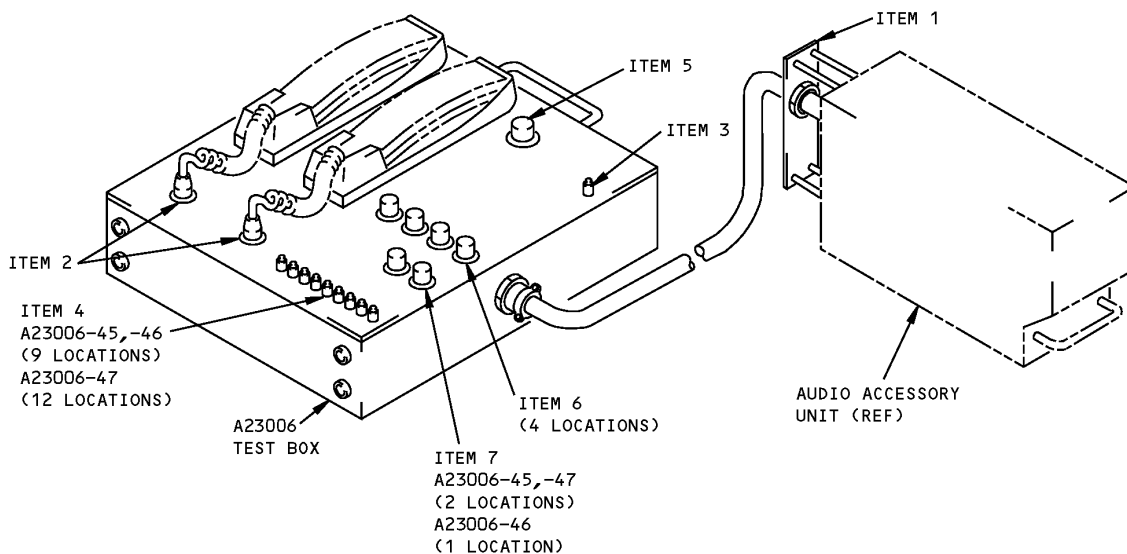

**Audio Accessory Unit Test Box**  
**Figure 1**

| <b>REPAIRABLE/REPLACEABLE PARTS</b> |                   |                     |                    |
|-------------------------------------|-------------------|---------------------|--------------------|
| <b>ITEM NO.</b>                     | <b>PART NO.</b>   | <b>NOMENCLATURE</b> | <b>VENDOR CODE</b> |
| 1                                   | BKAD1-125-30001   | CONNECTOR           | V71468             |
| 2                                   | C5F               | AUDIO RECEPTACLE    | V82389             |
| 3                                   | 507-3918-1471-600 | 28V RED LAMP        | V83330             |
| 4                                   | 507-3918-1473-600 | 28V AMBER LAMP      | V83330             |
| 5                                   | PA-4001           | ROTARY SWITCH       |                    |
| 6                                   | PSA-201           | ROTARY SWITCH       |                    |
| 7                                   | PSA-211           | ROTARY SWITCH       |                    |

**767**  
**ILLUSTRATED TOOL AND EQUIPMENT MANUAL**

**PART NUMBER: B23001-1**

**NAME:** EXTENDER BOARD - AUDIO ACCESSORY UNIT ASSEMBLY

**AIRPLANE MAINTENANCE:** NO

**COMPONENT MAINTENANCE:** YES

**USAGE & DESCRIPTION:** The B23001 drawing has been transferred to BAE Systems and will no longer be revised by Boeing. The B23001 inclusion in the 767 ITEM is for information and historical purposes only.

Used in conjunction with A23006 Audio Accessory Unit Test Box during test of 285T0001 Audio Accessory Unit Assembly. The Extender Board Assembly consists of a printed circuit board, bracket, solder and wire wrap.

**DIMENSIONS:** 5 x 10 inches (127 x 254 mm)

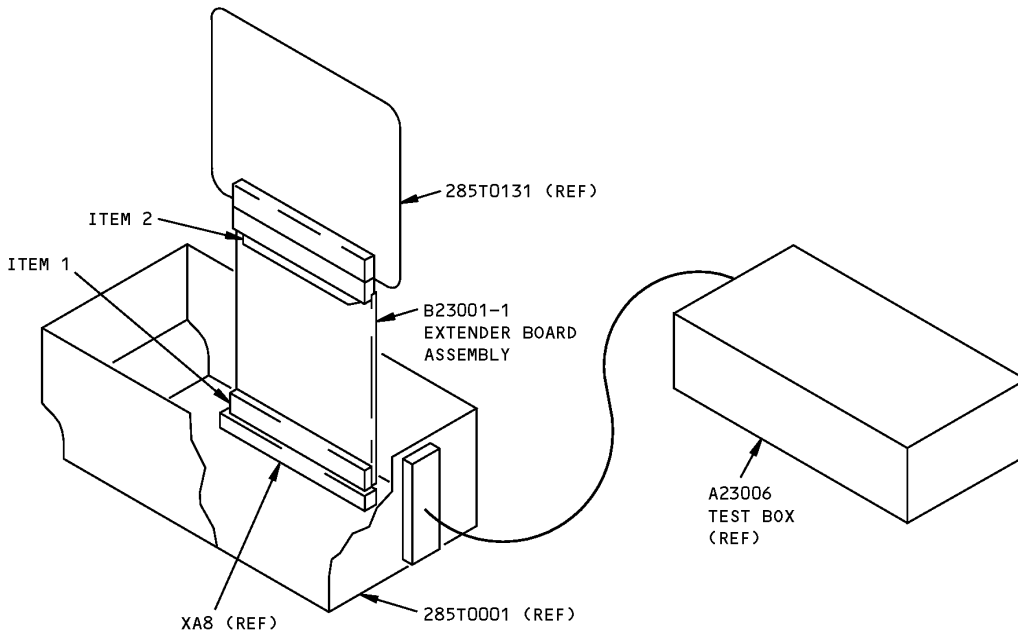

**Audio Accessory Unit Assembly Extender Board**  
**Figure 1**

| <b>REPAIRABLE/REPLACEABLE PARTS</b> |                    |                     |                    |
|-------------------------------------|--------------------|---------------------|--------------------|
| <b>ITEM NO.</b>                     | <b>PART NO.</b>    | <b>NOMENCLATURE</b> | <b>VENDOR CODE</b> |
| 1                                   | 300044-001 (OPT)   | CONNECTOR           | V03877             |
| 1                                   | 191-366-0006 (OPT) | CONNECTOR           | V26742             |
| 2                                   | 300052-004 (OPT)   | CONNECTOR           | V03877             |





767

ILLUSTRATED TOOL AND EQUIPMENT MANUAL

| REPAIRABLE/REPLACEABLE PARTS |                    |              |             |
|------------------------------|--------------------|--------------|-------------|
| ITEM NO.                     | PART NO.           | NOMENCLATURE | VENDOR CODE |
| 2                            | 192-366-0010 (OPT) | CONNECTOR    | V26742      |

## ILLUSTRATED TOOL AND EQUIPMENT MANUAL

PART NUMBER: C23002-1

**NAME:** ACOUSTIC COUPLER EQUIPMENT - TRANSMITTER AND RECEIVER ASSEMBLY

**AIRPLANE MAINTENANCE:** NO

**COMPONENT MAINTENANCE:** YES

**USAGE & DESCRIPTION:** The C23002 drawing has been transferred to BAE Systems and will no longer be revised by Boeing. The C23002 inclusion in the 767 ITEM is for information and historical purposes only.

This tool is used to connect the cabin attendant handset to sound level calibrator and sound level meter for functional testing of the handset module. Refer to CMM 23-42-15 for further usage instructions. This tool is used on the 767-400 airplanes. This tool consists of a transmitter assembly, a receiver assembly and a storage box assembly.

**WEIGHT:** 2 lbs (0.9 kg)

**DIMENSIONS:** 3 x 8 x 8 inches (76 x 203 x 203 mm)

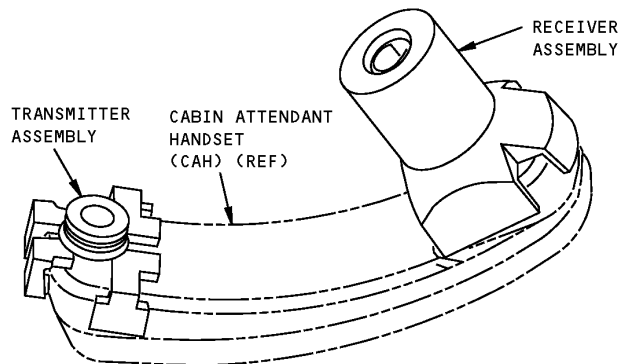

**Transmitter and Receiver Assembly Acoustic Coupler Equipment  
Figure 1**

## ILLUSTRATED TOOL AND EQUIPMENT MANUAL

PART NUMBER: PL1

NAME: PINGLITE

AIRPLANE MAINTENANCE: YES

COMPONENT MAINTENANCE: NO

**USAGE & DESCRIPTION:** This tool is used to check the operational status of Underwater Acoustic Beacons (pingers) in the 37.5 kHz range. It is intended primarily for use as a hand held, self-contained, checkout device to perform an operational test on a beacon without removing it from its mount on an aircraft, FDR, CVR, or other equipment.

**NOTE:** This tool is a supplier proprietary item and can only be obtained from Dukane, Seacom Division, St. Charles, Illinois 60174.

**NOTE:** PL1 replaces 42A12

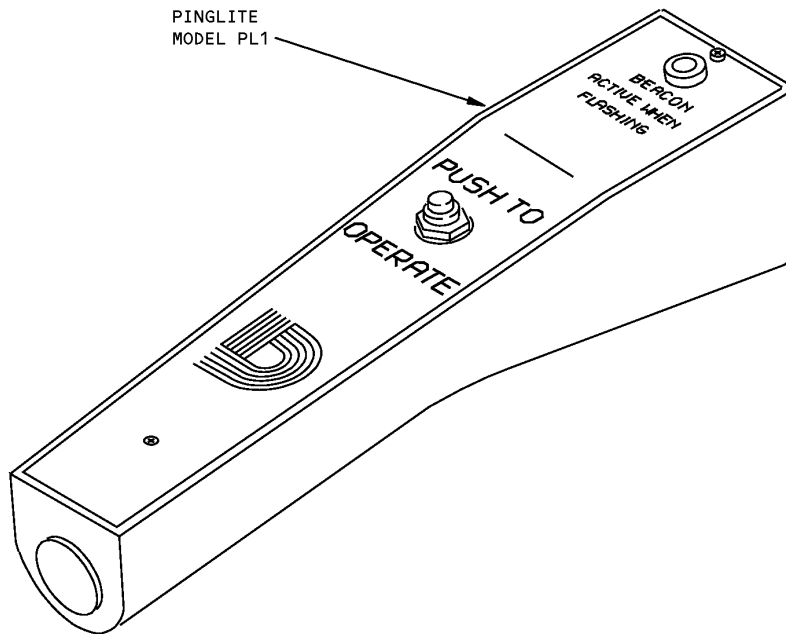

**Pinglite  
Figure 1**



767

**ILLUSTRATED TOOL AND EQUIPMENT MANUAL**

**PART NUMBER: 810-325**

**NAME:** SPANNER WRENCH

**AIRPLANE MAINTENANCE:** YES

**COMPONENT MAINTENANCE:** YES

**USAGE & DESCRIPTION:** The 810-325 spanner wrench is used to remove/install battery access covers of Dukane Underwater Locator Beacon (ULB) on Honeywell Voice Recorders and Flight Data Recorders. Refer to 767 AMM's 23-71-03, 31-31-02, and Honeywell CMM's 23-70-40, 23-70-44, 31-30-32, 31-30-37, 31-30-40 for further usage instructions.

**NOTE:** This tool is a supplier proprietary item and can only be obtained from Dukane, Ultrasonic Division, St. Charles, Illinois 60174.

**767  
ILLUSTRATED TOOL AND EQUIPMENT MANUAL**

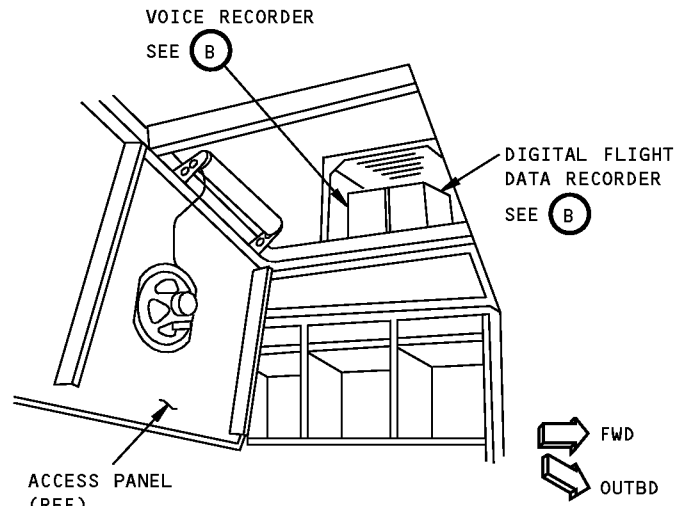
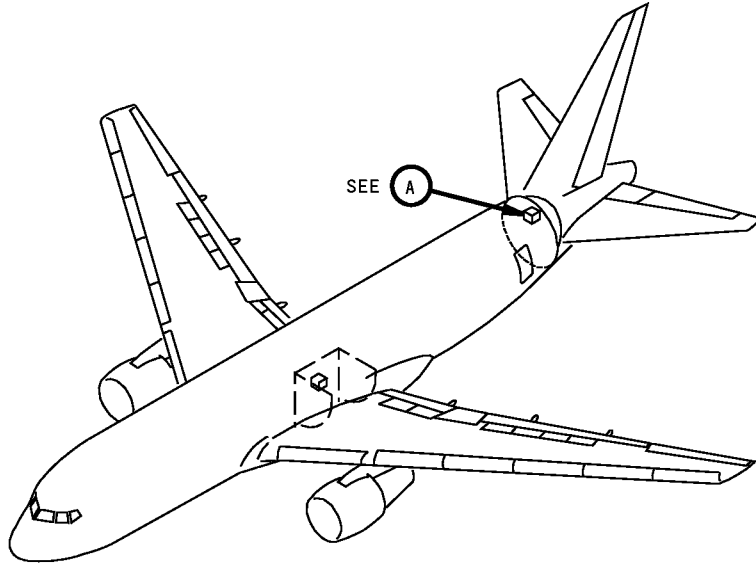

**VOICE RECORDER AND FLIGHT RECORDER  
(ELECTRONIC EQUIPMENT RACK, E7)**

**A**

**Voice Recorder and Flight Data Recorder Location  
Figure 1**

**ILLUSTRATED TOOL AND EQUIPMENT MANUAL**

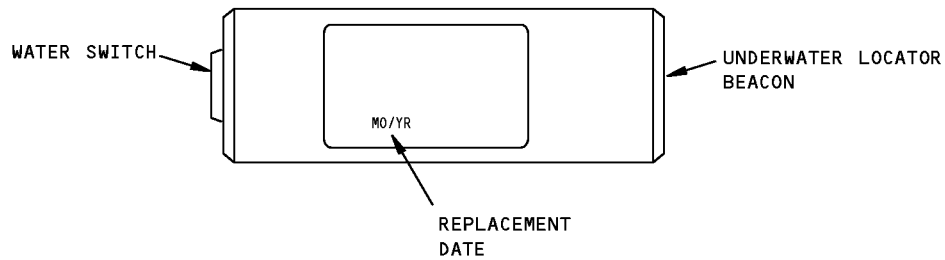
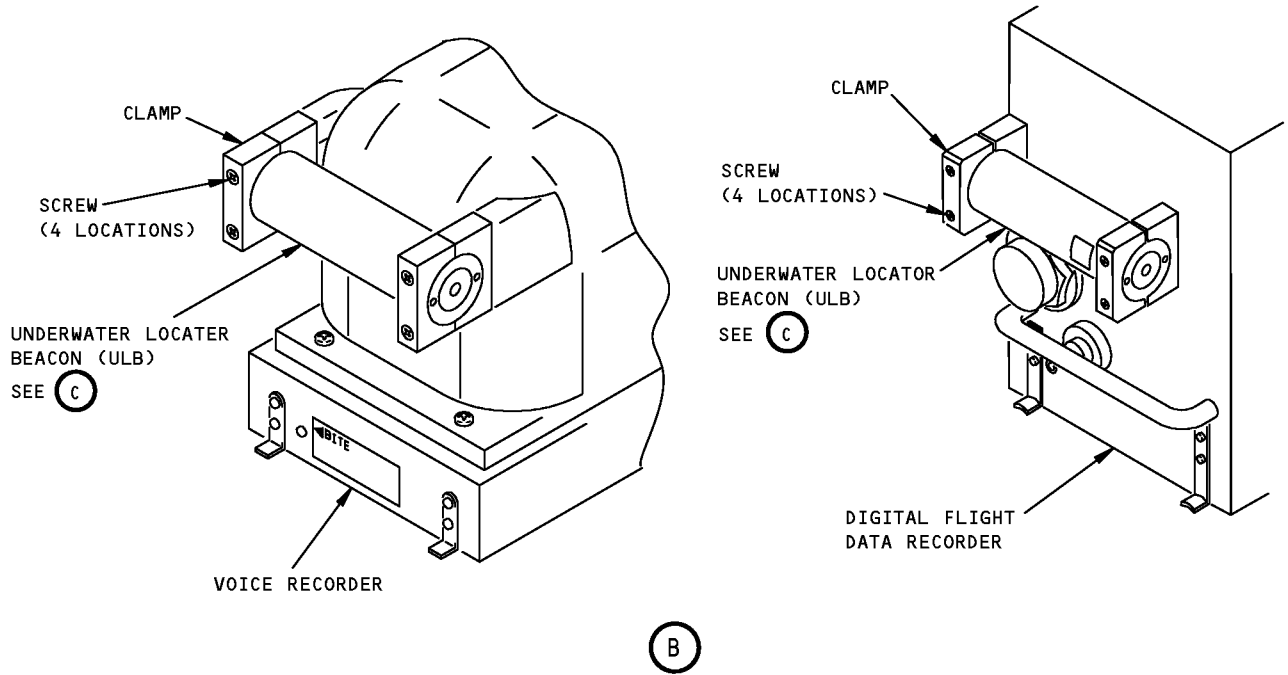

**UNDERWATER LOCATOR BEACON (ULB)**

(C)

**Underwater Locator Beacon (ULB) Location  
Figure 2**

**ILLUSTRATED TOOL AND EQUIPMENT MANUAL**

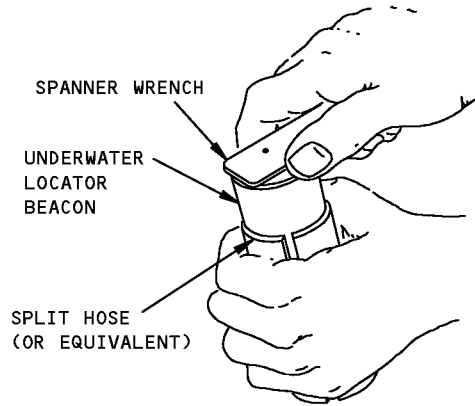

**ULB DISASSEMBLY (BATTERY ACCESS)**

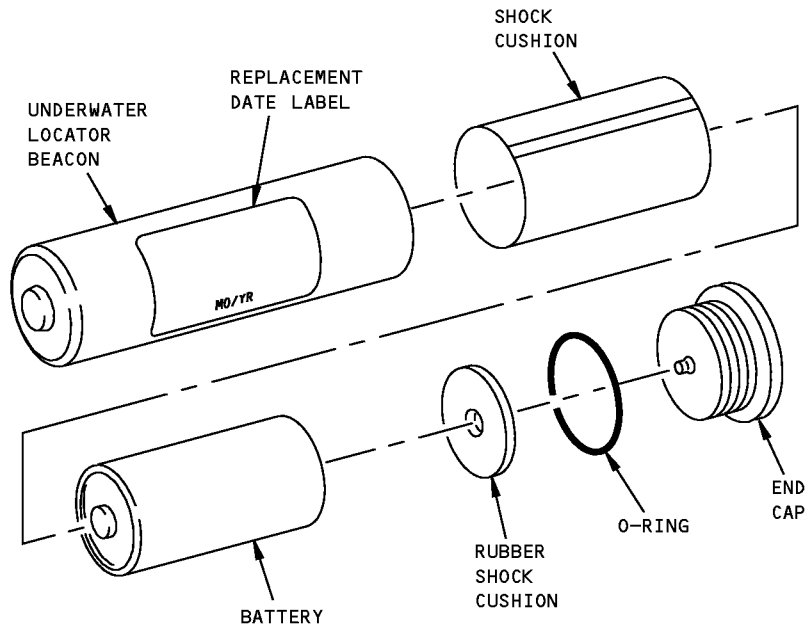

**BATTERY INSTALLATION**

**Underwater Locator Beacon (ULB) Battery Installation  
Figure 3**