

CHAPTER

25

**EQUIPMENT/
FURNISHINGS**



767
ILLUSTRATED TOOL AND EQUIPMENT MANUAL

CHAPTER 25
EQUIPMENT/FURNISHINGS

Subject/Page	Date	Subject/Page	Date	Subject/Page	Date
EFFECTIVE PAGES		25-50-01 (cont)		25-60-08 (cont)	
1	Apr 10/2008	2	Apr 10/2006	2	BLANK
2	BLANK	25-50-02			
25-CONTENTS		1	Apr 10/2006		
1	Apr 10/2006	2	BLANK		
2	BLANK	25-50-03			
25-10-01		1	Apr 10/2006		
1	Apr 10/2006	2	Apr 10/2006		
2	BLANK	25-50-04			
25-20-01		1	Apr 10/2006		
1	Apr 10/2006	2	Apr 10/2006		
2	Apr 10/2006	25-60-01			
25-20-02		1	Apr 10/2006		
1	Apr 10/2006	2	Apr 10/2006		
2	Apr 10/2006	3	Apr 10/2006		
25-20-03		4	BLANK		
1	Apr 10/2006	25-60-02			
2	Apr 10/2006	1	Apr 10/2006		
25-20-04		2	BLANK		
1	Apr 10/2006	25-60-03			
2	Apr 10/2006	1	Apr 10/2006		
25-20-05		2	Apr 10/2006		
1	Apr 10/2006	25-60-04			
2	BLANK	1	Apr 10/2006		
25-20-06		2	Apr 10/2006		
1	Apr 10/2006	25-60-05			
2	Apr 10/2006	1	Apr 10/2006		
25-20-07		2	Apr 10/2006		
1	Apr 10/2006	3	Apr 10/2006		
2	Apr 10/2006	4	BLANK		
25-30-01		25-60-06			
1	Apr 10/2006	1	Oct 10/2006		
2	Apr 10/2006	2	Oct 10/2006		
3	Apr 10/2006	3	Oct 10/2006		
4	BLANK	4	BLANK		
25-30-02		25-60-07			
1	Apr 10/2006	1	Apr 10/2006		
2	Apr 10/2006	2	BLANK		
25-50-01		25-60-08			
1	Apr 10/2006	1	Apr 10/2006		

A = Added, R = Revised, O = Overflow, D = Deleted

25-EFFECTIVE PAGES



767

ILLUSTRATED TOOL AND EQUIPMENT MANUAL

TABLE OF CONTENTS

<u>Subject</u>	<u>Title</u>	<u>Part No.</u>
25-	EQUIPMENT/FURNISHINGS	
25-10-01	ADJUSTOR - FRICTION BALL CATCH	A25017-1
25-20-01	INSTALLATION EQUIPMENT - LUGGAGE BIN SNUBBER	A25008-1
25-20-02	WRENCH SET - STOWAGE BIN RELEASE	A25018-10
25-20-03	GAGE-INSPECTION, SEAT TRACK, FLIGHT CREW	A25020-1, -4, -8
25-20-04	WRENCH, SPANNER TYPE	ST2580-163A
25-20-05	LEVER- STOWAGE BIN RELEASE	J25001-5
25-20-06	STANDARD TOOL - SPANNER NOSE PLIERS	ST2580-334C
25-20-07	WRENCH - ANTI-RATTLE NUT	C25001-1
25-30-01	REPLACEMENT EQUIPMENT - AIR CHILLER, FWD GALLEY	A25001-33
25-30-02	SLIDE BAR - AFT GALLEY AIR CHILLER	A25002-1
25-50-01	REMOVAL TOOL - BALL TRANSFER UNIT	A25009-2
25-50-02	PUSH PLATE - SPRING LOADED PDU	A25021-1
25-50-03	TEST EQUIPMENT - PDU, GUIDES, AND ROLLOUT STOPS	A25022-1
25-50-04	TEST EQUIPMENT - LATERAL GUIDE ASSEMBLY	J25003-35
25-60-01	SIMULATOR - DOOR OPENING ACTUATOR, OFF-WING ESCAPE SLIDE	A25003-24
25-60-02	SIMULATOR EQUIPMENT - OFF-WING ESCAPE SLIDE DOOR LATCH OPENING ACTUATOR	A25004-1
25-60-03	SIMULATOR - GAS PRESSURE VESSEL	A25005-29
25-60-04	WRENCH - INTEGRATOR, OFF-WING ESCAPE SYSTEM	A25011-2
25-60-05	ELECTRICAL TEST EQUIPMENT - OFF-WING ESCAPE SLIDE SYSTEM	A25012-19, -29
25-60-06	SIMULATOR EQUIPMENT - LATCH OPENING, OFF-WING ESCAPE SYSTEM	A25014-29
25-60-07	SAFETY EQUIPMENT - ESCAPE SYSTEM, OFF-WING	A25016-1
25-60-08	GAGE - ACTUATOR, LATCH OPENING, OFF-WING ESCAPE SYSTEM	A25019-1

25-CONTENTS

ILLUSTRATED TOOL AND EQUIPMENT MANUAL

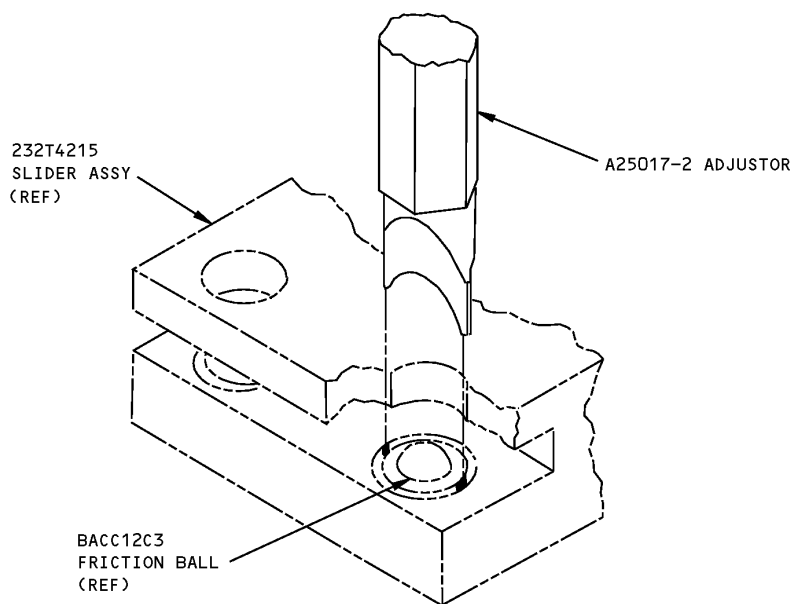
PART NUMBER: A25017-1**NAME:** ADJUSTOR - FRICTION BALL CATCH**AIRPLANE MAINTENANCE:** YES**COMPONENT MAINTENANCE:** NO**USAGE & DESCRIPTION:** Use to adjust the BACC12C3 friction-ball catch. The A25017-1 is used on the sunvisor slider adjustor and other locations. This tool consists of a -2 adjustor in a -3 bag.**WEIGHT:** 1 lb (0.45 kg)**DIMENSIONS:** 3 x 2 x 2 inches (76 x 51 x 51 mm)

**Friction Ball Catch Adjustor
Figure 1**



767

ILLUSTRATED TOOL AND EQUIPMENT MANUAL

PART NUMBER: A25008-1

NAME: INSTALLATION EQUIPMENT - LUGGAGE BIN SNUBBER

AIRPLANE MAINTENANCE: YES

COMPONENT MAINTENANCE: NO

USAGE & DESCRIPTION: This tool is used to install the luggage bin snubber; using the hollow, notched tube to compress the extended snubber, and the rod to align the snubber to the slotted-head screw.

WEIGHT: 1 lb (0.45 kg)

DIMENSIONS: 2 x 6 x 8 inches (51 x 152 x 203 mm)

**767
ILLUSTRATED TOOL AND EQUIPMENT MANUAL**

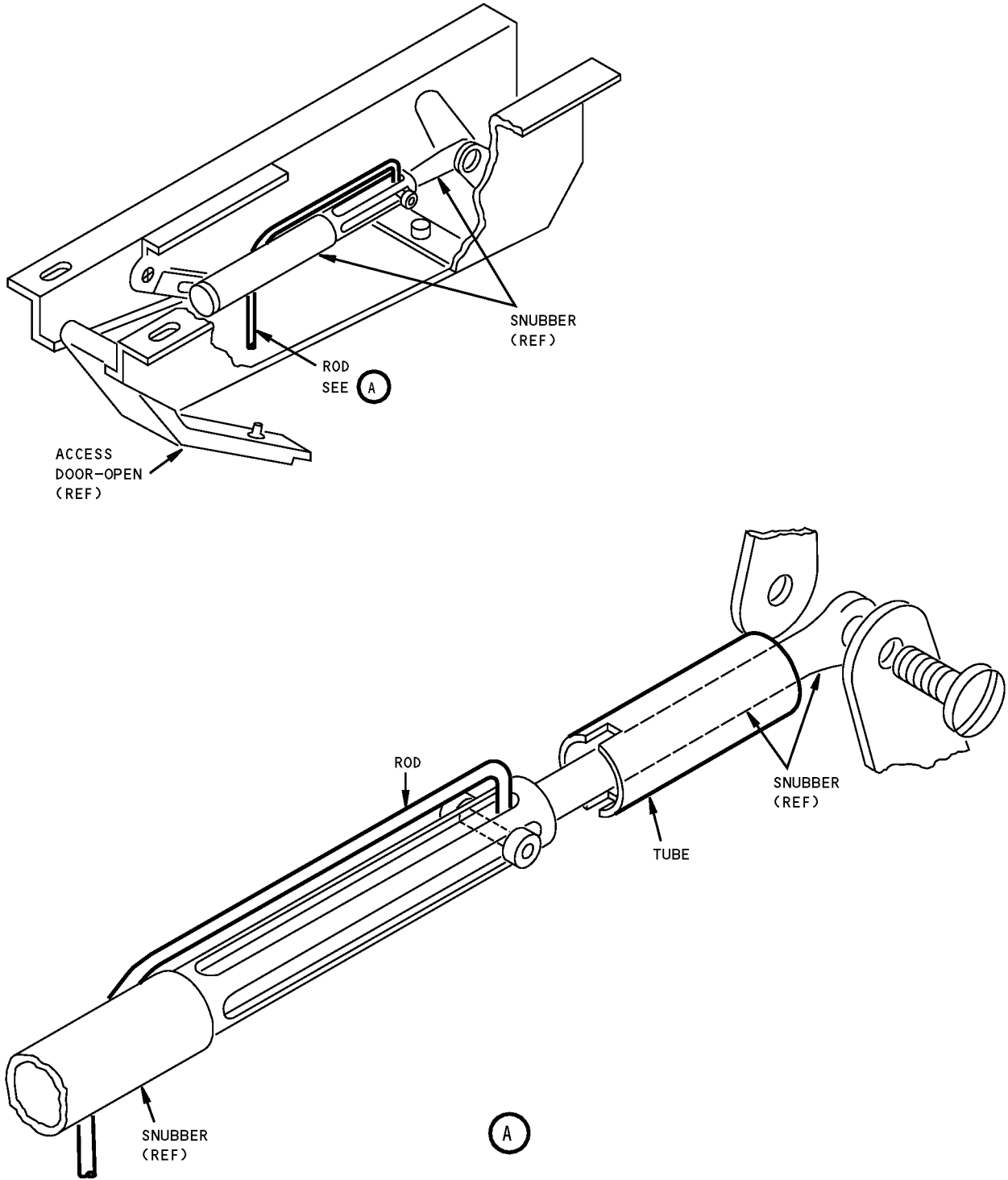

**Luggage Bin Snubber Installation Equipment
Figure 1**



767

ILLUSTRATED TOOL AND EQUIPMENT MANUAL

PART NUMBER: A25018-10

NAME: WRENCH SET - STOWAGE BIN RELEASE

AIRPLANE MAINTENANCE: YES

COMPONENT MAINTENANCE: NO

USAGE & DESCRIPTION: Used to release jammed center overhead stowage bin latches. This tool set is required only for S413T103 latches not equipped with emergency release levers. This tool consists of a -11 lever assembly and a -12 lever assembly, in a -8 box assembly.

WEIGHT: 2 lbs (1 kg)

DIMENSIONS: 2 x 8 x 10 inches (51 x 203 x 254 mm) (excluding box)

NOTE: A25018-10 supersedes A25018-1.
A25018-1 supersedes A25013-1.
A25013-1 supersedes A25010-1.

**767
ILLUSTRATED TOOL AND EQUIPMENT MANUAL**

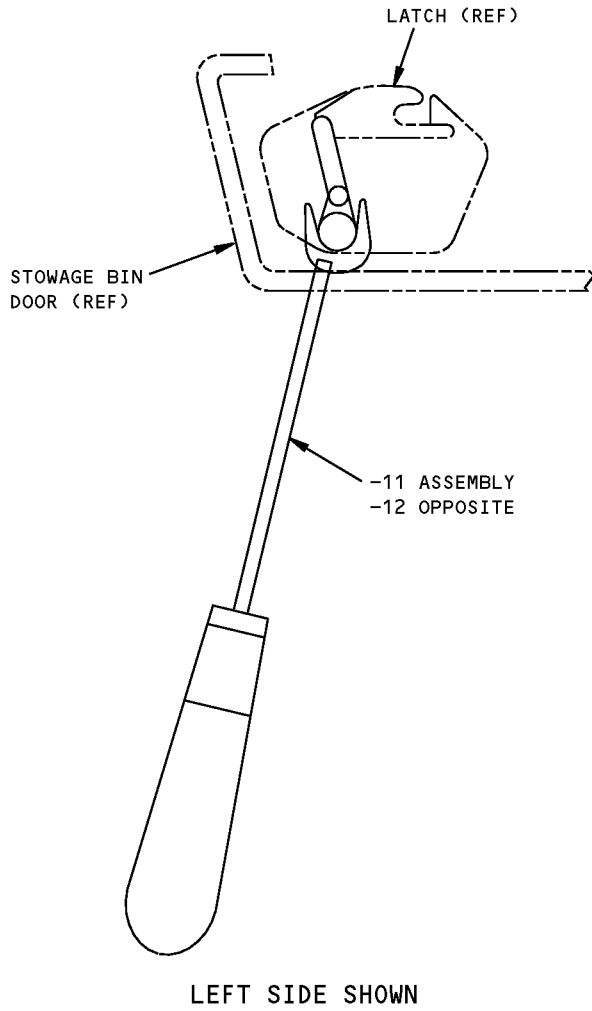

**Stowage Bin Release Wrench Set
Figure 1**



767

ILLUSTRATED TOOL AND EQUIPMENT MANUAL

PART NUMBER: A25020-1, -4, -8

NAME: GAGE-INSPECTION, SEAT TRACK, FLIGHT CREW

AIRPLANE MAINTENANCE: YES

COMPONENT MAINTENANCE: NO

USAGE & DESCRIPTION: The gages included in this tool are used to measure seat track wear to determine when the wear limit has been reached and the track should be replaced. Refer to AMM 25-11-01 for further usage instructions. Each gage consists of a steel bar with a protrusion that fits into the holes, and into the troughs worn between the holes of the seat tracks.

The -8 tool consists of 2 separate gages, a -5 gage which is used to measure IPECO seat tracks, and a -9 gage which is used to measure WEBER seat tracks. They are stored together in a -6 box assembly.

The -4 tool consists of only a -5 gage which is stored in a -6 box assembly.

The -1 tool consists of only a -2 gage which is stored in a -3 box assembly.

Both the -4 and the -1 tools are used to measure the IPECO seat tracks only.

WEIGHT: 1 lb (0.45 kg)

DIMENSIONS: 1 x 1 x 2 inches (25 x 25 x 51 mm)

NOTE: A25020-8 replaces A25020-4 for future procurement.
A25020-4 replaces A25020-1 for future procurement.

ILLUSTRATED TOOL AND EQUIPMENT MANUAL

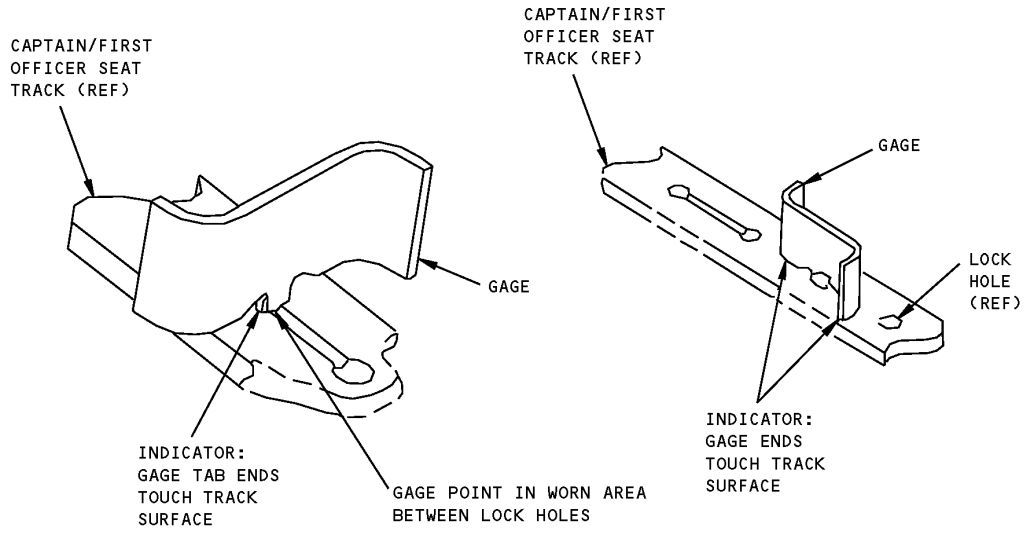

**Flight Crew Seat Track Inspection Gage
Figure 1**



767

ILLUSTRATED TOOL AND EQUIPMENT MANUAL

PART NUMBER: ST2580-163A

NAME: WRENCH, SPANNER TYPE

AIRPLANE MAINTENANCE: YES

COMPONENT MAINTENANCE: NO

USAGE & DESCRIPTION: This tool is used to tighten the anti-rattle nut part number 823377-403 that connect the front legs on Weber passenger seats to the airplane seat tracks. This tool consists of a half socket with a handle welded to it.

DIMENSIONS: 1.5 x 7.0 inches (38 x 178 mm)

NOTE: ST2580-334C replaces ST2580-163A for future procurement.

ILLUSTRATED TOOL AND EQUIPMENT MANUAL

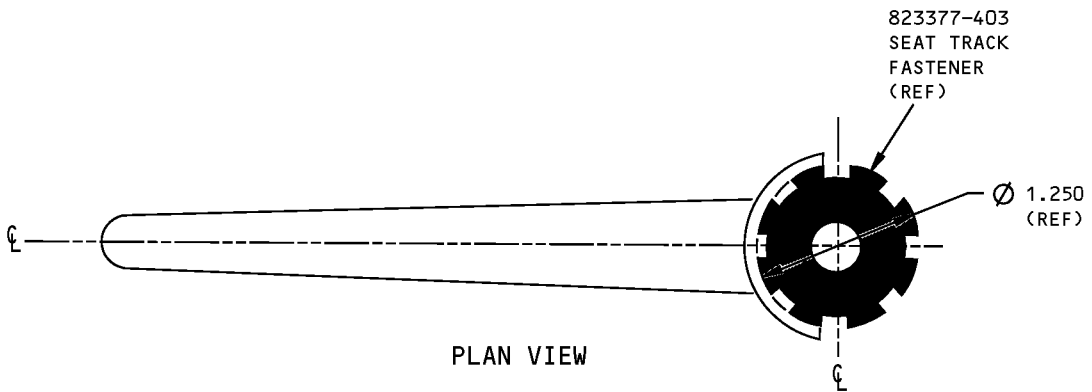
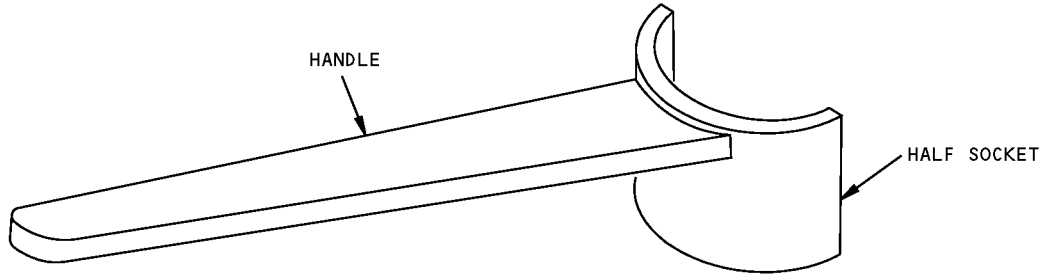

**Spanner Type Wrench
Figure 1**

ILLUSTRATED TOOL AND EQUIPMENT MANUAL

PART NUMBER: J25001-5**NAME:** LEVER- STOWAGE BIN RELEASE**AIRPLANE MAINTENANCE:** YES**COMPONENT MAINTENANCE:** NO

USAGE & DESCRIPTION: This lever is used to actuate the emergency release latch on overhead bins. Refer to AMM 25-28-01 and AMM 25-28-03 for further usage instructions. This tool is used on 767-400 airplanes. This tool consists of a tool assembly and a storage box assembly.

DIMENSIONS: 1 x 3 x 10 inches (25 x 76 x 254 mm)

NOTE: J25001-5 supersedes J25001-1.

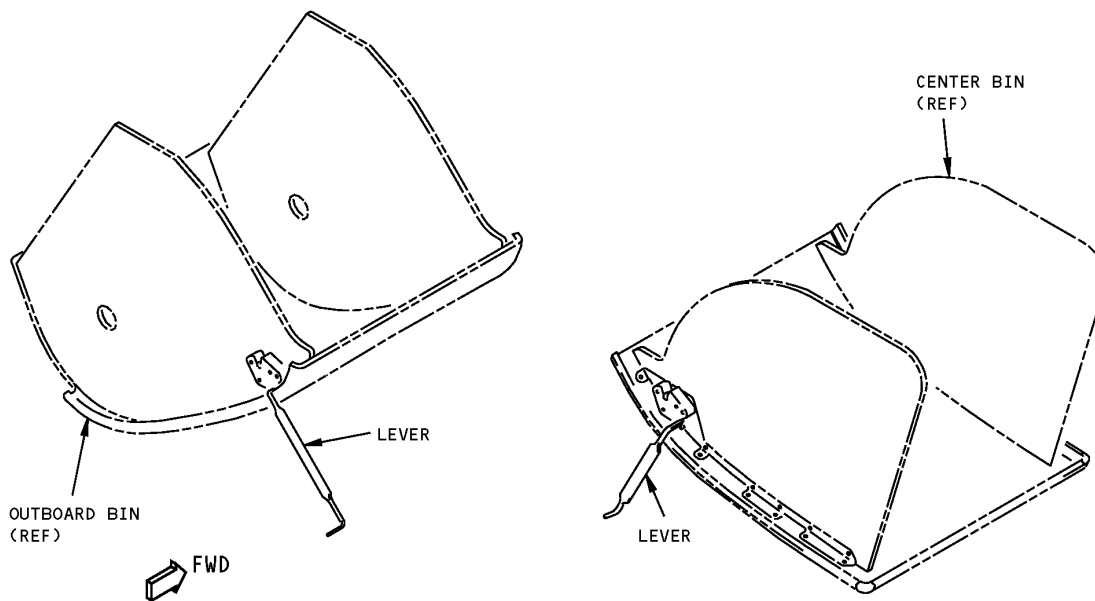

**Stowage Bin Release Lever
Figure 1**



767

ILLUSTRATED TOOL AND EQUIPMENT MANUAL

PART NUMBER: ST2580-334C

NAME: STANDARD TOOL - SPANNER NOSE PLIERS

AIRPLANE MAINTENANCE: YES

COMPONENT MAINTENANCE: NO

USAGE & DESCRIPTION: This tool is used to tighten anti-rattle nuts on passenger seats to seat tracks. Refer to AMM 25-25-01 for further usage instructions. The tool comes in two sizes: The -145, (0.145 inch spanner teeth) used on Rumbold seats and -185, (0.185 inch spanner teeth) used on Weber, Sicma and Recaro seats.

DIMENSIONS: 3 x 3 x 10 inches (76 x 76 x 254 mm)

NOTE: ST2580-334C replaces ST2580-163A for future procurement.

TABLE 1

A DIAMETER + 0.005 or -0.005	SEAT VENDOR	TOOL PART NO.	NUT PART NO.
0.185	RECARO	ST2580-334C-1-185	134-00-101-09
0.185	SICMA	ST2580-334C-1-185	91-000100-726-0
0.185	WEBER	ST2580-334C-1-185	823377-403
0.185	WEBER	ST2580-334C-1-185	845901-401
0.145	RUMBOLD	ST2580-334C-1-145	M78203-662

ILLUSTRATED TOOL AND EQUIPMENT MANUAL

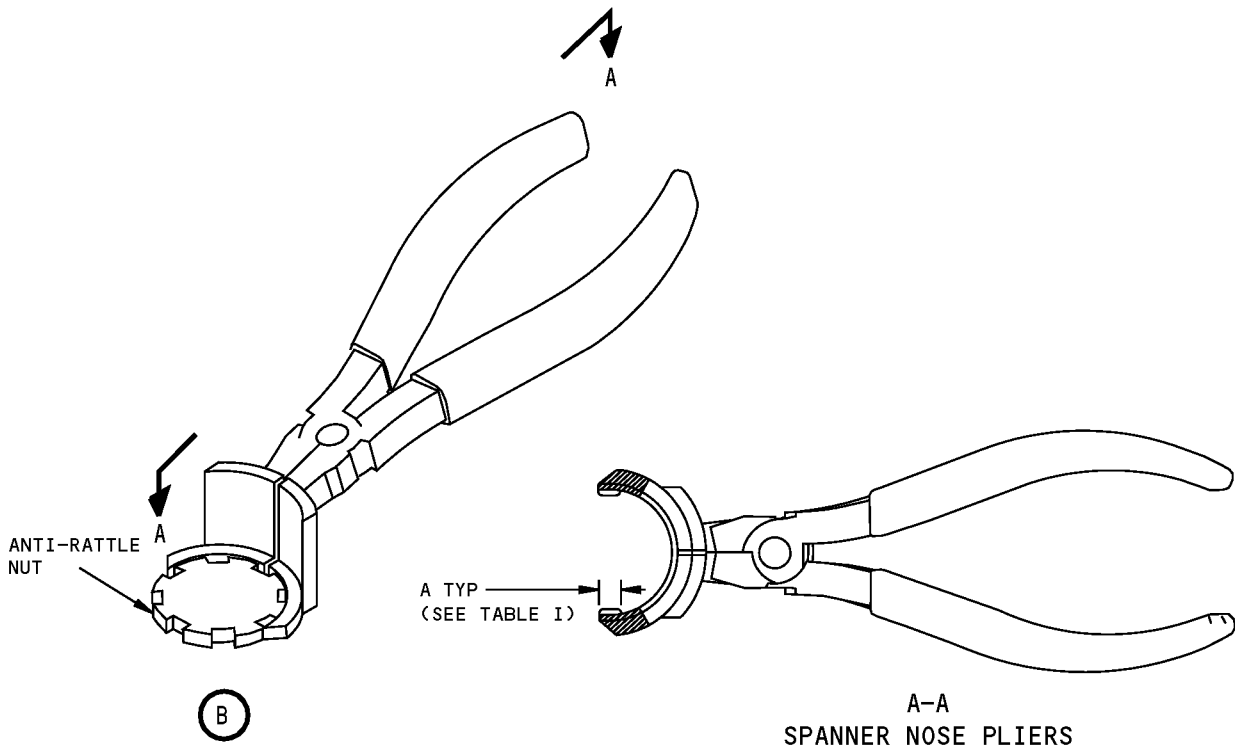
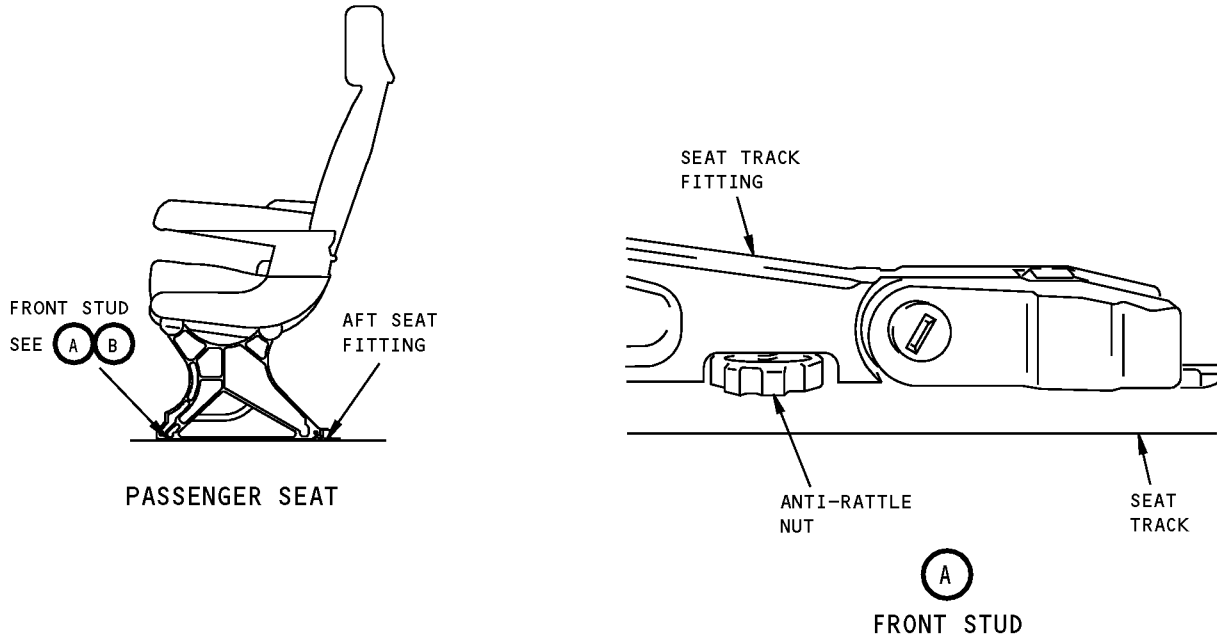

**Spanner Nose Pliers Standard Tool
Figure 1**



767

ILLUSTRATED TOOL AND EQUIPMENT MANUAL

PART NUMBER: C25001-1

NAME: WRENCH - ANTI-RATTLE NUT

AIRPLANE MAINTENANCE: YES

COMPONENT MAINTENANCE: NO

USAGE & DESCRIPTION: The C25001-1 wrench is used on all 767 passenger airplanes equipped with certain Recardo, Sicma, Weber and Rumbold passenger seats. The C25001 wrench is used to tighten and loosen Recardo 134-00-101-09, Sicma 91-000100-726-0, Weber 82377-403 and 845901-401 and Rumbold M78203-662 anti-rattle nuts. Refer to AMM 25-20-01 for complete usage instructions. C25001-1 consists of a C25001-2 wrench assembly contained in a storage box.

WEIGHT: 1 lb (0.45 kg)

DIMENSIONS: 2 x 6 x 10 inches (51 x 152 x 254 mm)

ILLUSTRATED TOOL AND EQUIPMENT MANUAL

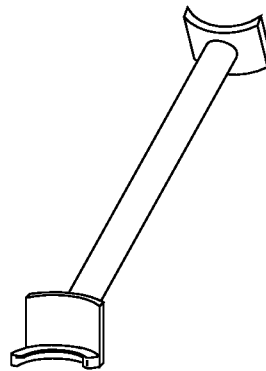
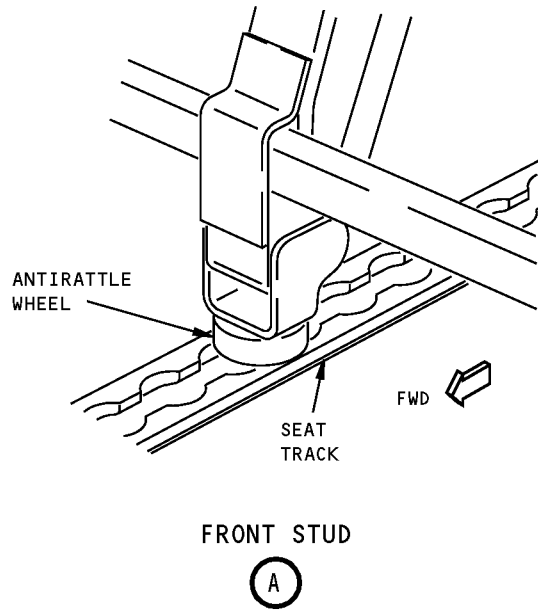
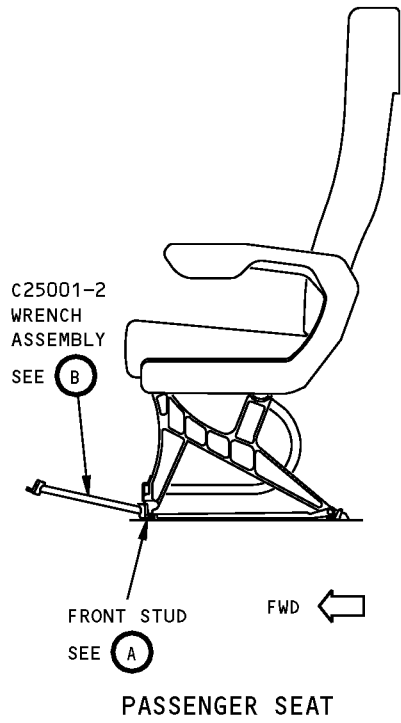

C25001-2
WRENCH ASSEMBLY

(B)

**Anti-Rattle Nut Wrench
Figure 1**

ILLUSTRATED TOOL AND EQUIPMENT MANUAL

PART NUMBER: A25001-33

NAME: REPLACEMENT EQUIPMENT - AIR CHILLER, FWD GALLEY

AIRPLANE MAINTENANCE: YES

COMPONENT MAINTENANCE: NO

USAGE & DESCRIPTION: This tool is a ramp assembly to position the air chiller for lowering through the E/E compartment access door during removal or returning the chiller to the position of installation. A customer furnished fishpole hoist is used during ramp positioning and also in lowering/hoisting the chiller. Approximate weight of the chiller is 85 lbs. This tool is used on all 767 airplanes with a lower lobe chiller.

WEIGHT: 40 lbs (18 kg)

DIMENSIONS: 4 x 55 x 63 inches (102 x 1397 x 1600 mm)

NOTE: A25001-33 supersedes A25001-1.

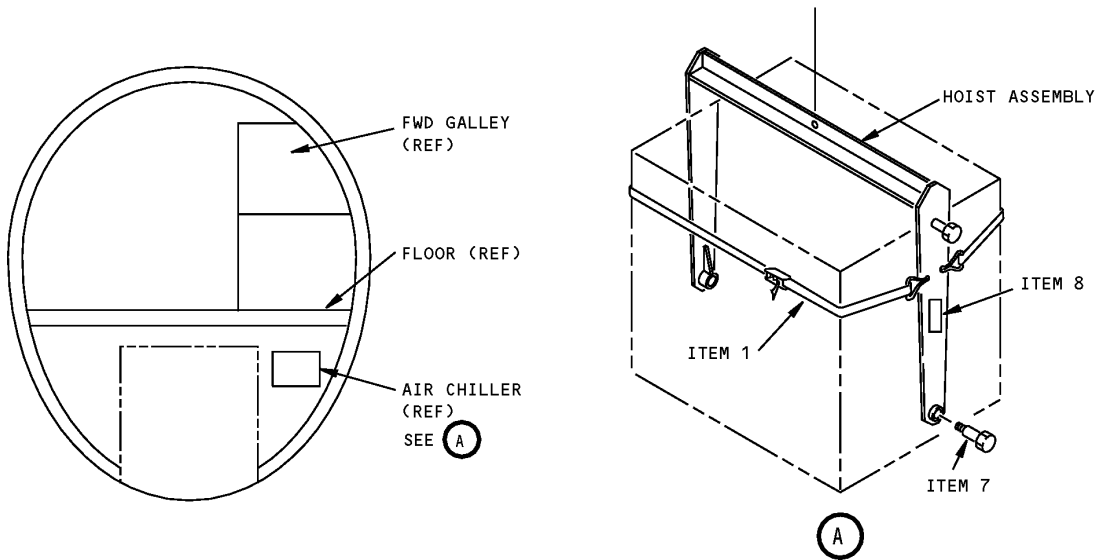

**Forward Galley Air Chiller Replacement Equipment
Figure 1 (Sheet 1 of 3)**

ILLUSTRATED TOOL AND EQUIPMENT MANUAL

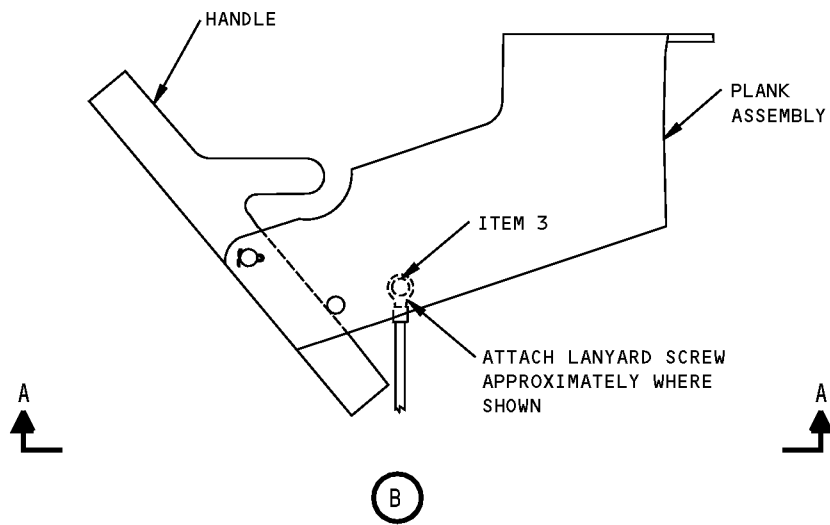
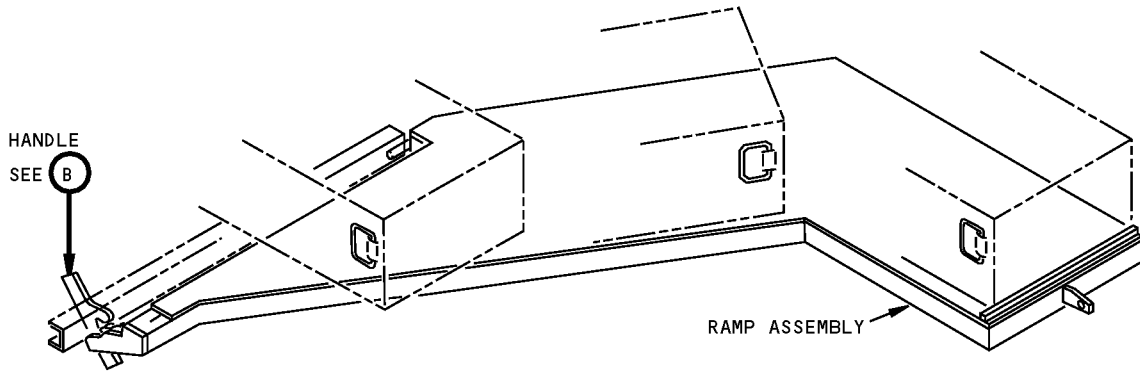

**Forward Galley Air Chiller Replacement Equipment
Figure 1 (Sheet 2 of 3)**

767
ILLUSTRATED TOOL AND EQUIPMENT MANUAL

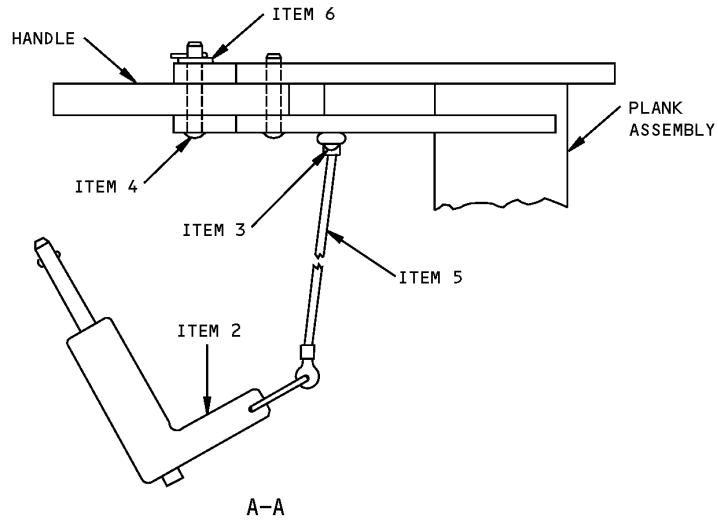

Forward Galley Air Chiller Replacement Equipment
Figure 1 (Sheet 3 of 3)

REPAIRABLE/REPLACEABLE PARTS			
ITEM NO.	PART NO.	NOMENCLATURE	VENDOR CODE
1	3101003LO30-015	STRAP ASSEMBLY	V01276
2	NAS1334A5C11D	BALL LOCKPIN	
3	MS21318-27	SCREW	
4	MS20392-3637	PIN	
5	CL-63-KA-6L	ATTACH CABLE	V99862
6	AN960-416	WASHER	
7	-39	BOLT ASSEMBLY	
8	F70308-2	PROOF LOAD TAG	



767

ILLUSTRATED TOOL AND EQUIPMENT MANUAL

PART NUMBER: A25002-1

NAME: SLIDE BAR - AFT GALLEY AIR CHILLER

AIRPLANE MAINTENANCE: YES

COMPONENT MAINTENANCE: NO

USAGE & DESCRIPTION: This tool is used to protect the edge of aft galley air chiller drip pan during removal and installation procedures. This tool is used on 767-200/-200ER/-300/-300ER/-400/-400ER, airplanes that are equipped with lower lobe chillers which have drain pans. The slide bar is a nylon strip which clips over the lip of the drip pan.

WEIGHT: 1 lb (0.45 kg)

DIMENSIONS: 1 x 1 x 18 inches (25 x 25 x 457 mm)

767
ILLUSTRATED TOOL AND EQUIPMENT MANUAL

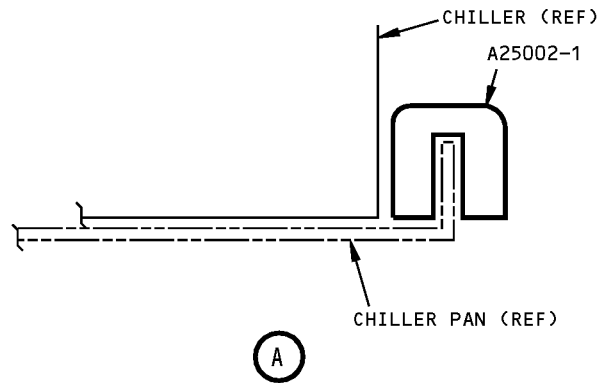
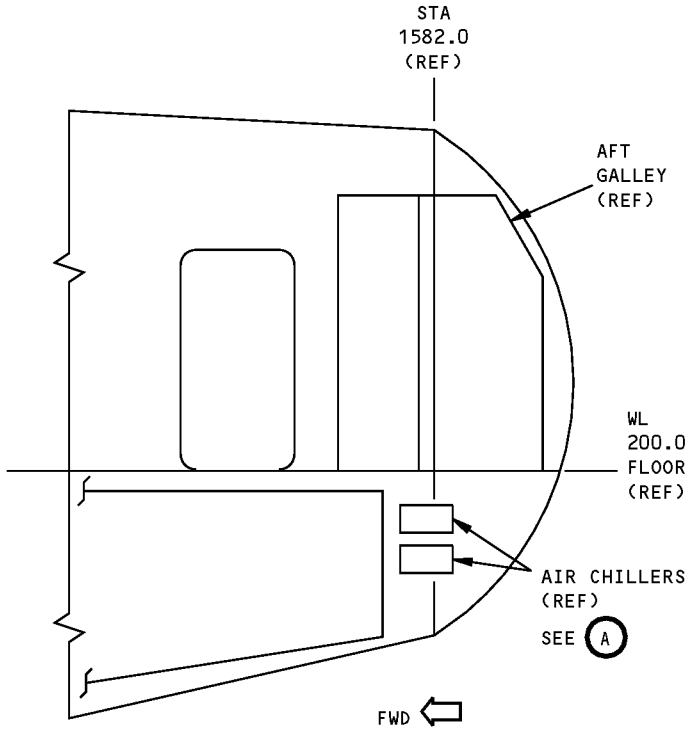

Aft Galley Air Chiller Slide Bar
Figure 1



767

ILLUSTRATED TOOL AND EQUIPMENT MANUAL

PART NUMBER: A25009-2

NAME: REMOVAL TOOL - BALL TRANSFER UNIT

AIRPLANE MAINTENANCE: YES

COMPONENT MAINTENANCE: NO

USAGE & DESCRIPTION: This tool consists of a drill template and a pair of pliers used to remove ball transfer units from the cargo compartment ball transfer panel.

DIMENSIONS: 3 x 4 x 9 inches (76 x 102 x 229 mm)

NOTE: A25009-2 supersedes A25009-1

ILLUSTRATED TOOL AND EQUIPMENT MANUAL

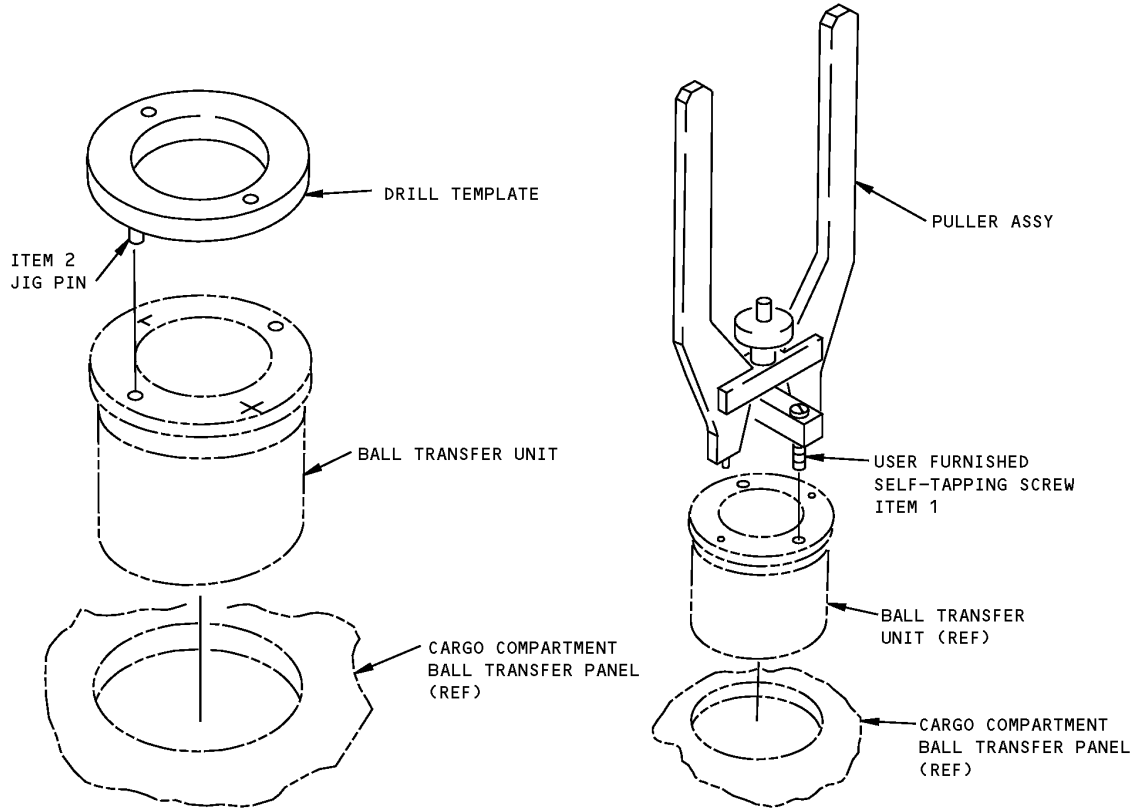

Ball Transfer Unit Removal Tool
Figure 1

REPAIRABLE/REPLACEABLE PARTS			
ITEM NO.	PART NO.	NOMENCLATURE	VENDOR CODE
1	-15	SET SCREW	
2	-14	PIN	

ILLUSTRATED TOOL AND EQUIPMENT MANUAL

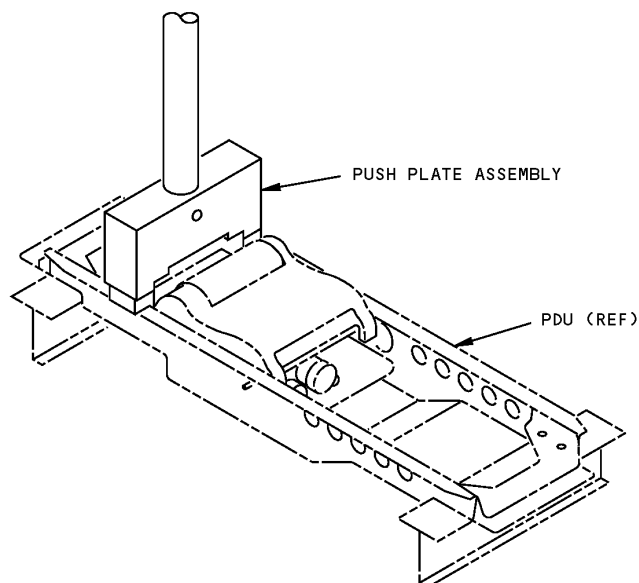
PART NUMBER: A25021-1**NAME:** PUSH PLATE - SPRING LOADED PDU**AIRPLANE MAINTENANCE:** YES**COMPONENT MAINTENANCE:** NO**USAGE & DESCRIPTION:** This tool is applicable to 767 freighter's only. This tool is used in the upper deck to depress and test the cargo system's spring loaded power drive units (PDU). This equipment consists of a push plate assembly, and a storage box. Refer to AMM 25-57-31 for further usage information.**WEIGHT:** 4 lbs (1.8 kg) (excluding box)**DIMENSIONS:** 2 x 7 x 42 inches (51 x 178 x 1067 mm) (excluding box)

**Spring Loaded Power Drive Unit Push Plate
Figure 1**

ILLUSTRATED TOOL AND EQUIPMENT MANUAL

PART NUMBER: A25022-1

NAME: TEST EQUIPMENT - PDU, GUIDES, AND ROLLOUT STOPS

AIRPLANE MAINTENANCE: YES

COMPONENT MAINTENANCE: NO

USAGE & DESCRIPTION: This equipment is used in the 767 general market freighter, to provide a means of breaking out wiring for testing and troubleshooting of the guides, rollout stops, and self-erecting power drive units. It consists of a test box assembly, an "A" adapter assembly, a "B" adapter assembly, and a storage box assembly. Refer to AMM 25-57-00-5 and 25-53-00-5 for further usage information.

WEIGHT: 40 lbs (18 kg) (excluding box)

DIMENSIONS: 12 x 20 x 30 inches (305 x 508 x 762 mm) (excluding box)

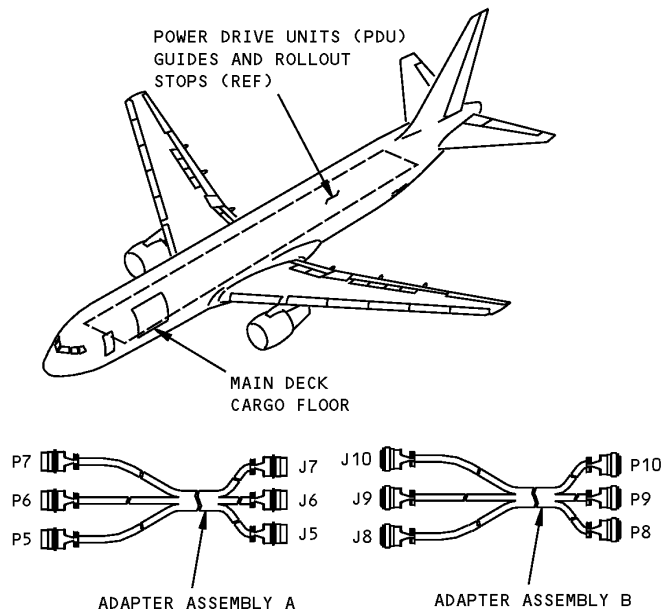

**Power Drive Unit Guides and Rollout Stops Test Equipment
Figure 1 (Sheet 1 of 2)**

ILLUSTRATED TOOL AND EQUIPMENT MANUAL

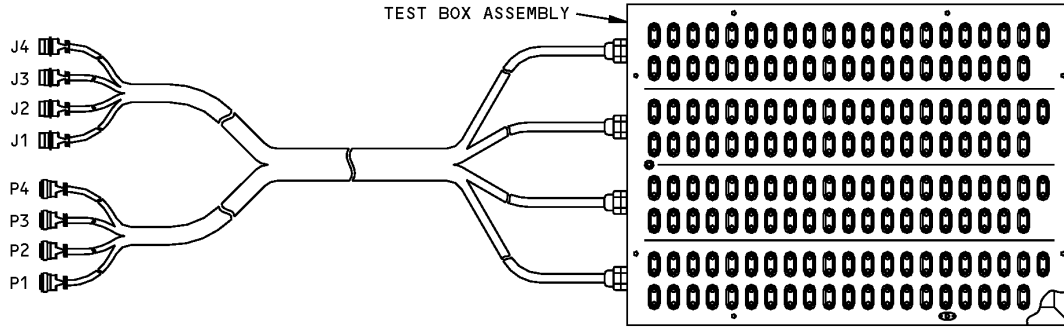

Power Drive Unit Guides and Rollout Stops Test Equipment
Figure 1 (Sheet 2 of 2)

REPAIRABLE/REPLACEABLE PARTS			
ITEM NO.	PART NO.	NOMENCLATURE	VENDOR CODE
1	MDP-S-O	SHORTING PLUG	V05276

767
ILLUSTRATED TOOL AND EQUIPMENT MANUAL

PART NUMBER: J25003-35

NAME: TEST EQUIPMENT - LATERAL GUIDE ASSEMBLY

AIRPLANE MAINTENANCE: NO

COMPONENT MAINTENANCE: YES

USAGE & DESCRIPTION: This equipment is used on all 767 airplanes except the 767 UPS freighter. This equipment is used to hold and test lateral guide assemblies during manual, electrical and pendulum test. It consists of a fixture assembly, a test box assembly, two mounting screws and a storage box assembly. Refer to CMM 25-53-14 for further usage information.

WEIGHT: 117 lbs (53 kg)

DIMENSIONS: 14 x 19 x 52 inches (356 x 483 x 1321 mm)

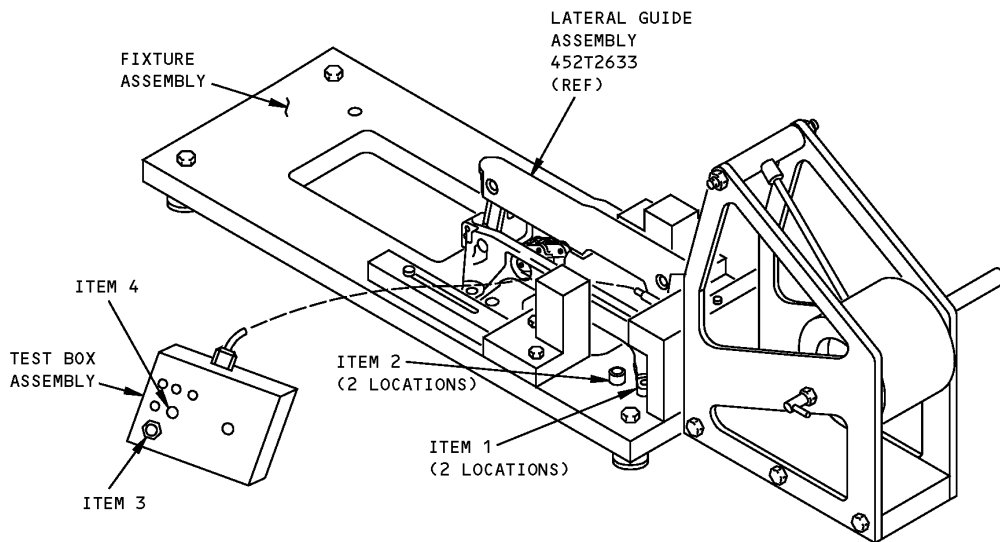

Lateral Guide Assembly Test Equipment
Figure 1

REPAIRABLE/REPLACEABLE PARTS			
ITEM NO.	PART NO.	NOMENCLATURE	VENDOR CODE
1	MS16997-97	SCREW	
2	MS16997-164	SCREW	
3	313001	FUSE	V75915



767

ILLUSTRATED TOOL AND EQUIPMENT MANUAL

REPAIRABLE/REPLACEABLE PARTS			
ITEM NO.	PART NO.	NOMENCLATURE	VENDOR CODE
4	507-4538-0931-610	LAMP	V83330



767

ILLUSTRATED TOOL AND EQUIPMENT MANUAL

PART NUMBER: A25003-24

NAME: SIMULATOR - DOOR OPENING ACTUATOR, OFF-WING ESCAPE SLIDE

AIRPLANE MAINTENANCE: YES

COMPONENT MAINTENANCE: NO

USAGE & DESCRIPTION: This tool is used for functional testing of the off-wing escape slide door opening actuator, by measuring the actuator firing pin travel. Both forward door and aft door actuators are removed and simulators mounted in their places. This tool is used on all 767 model airplanes except the 767-400ER and freighters. This tool consists of a simulator assembly and a box assembly.

WEIGHT: 3 lbs (1.4 kg)

DIMENSIONS: 3 x 8 x 10 inches (76 x 203 x 254 mm)

NOTE: A25003-24 supersedes A25003-20.
A25003-20 supersedes A25003-15.
A25003-15 supersedes A25003-8, -12.

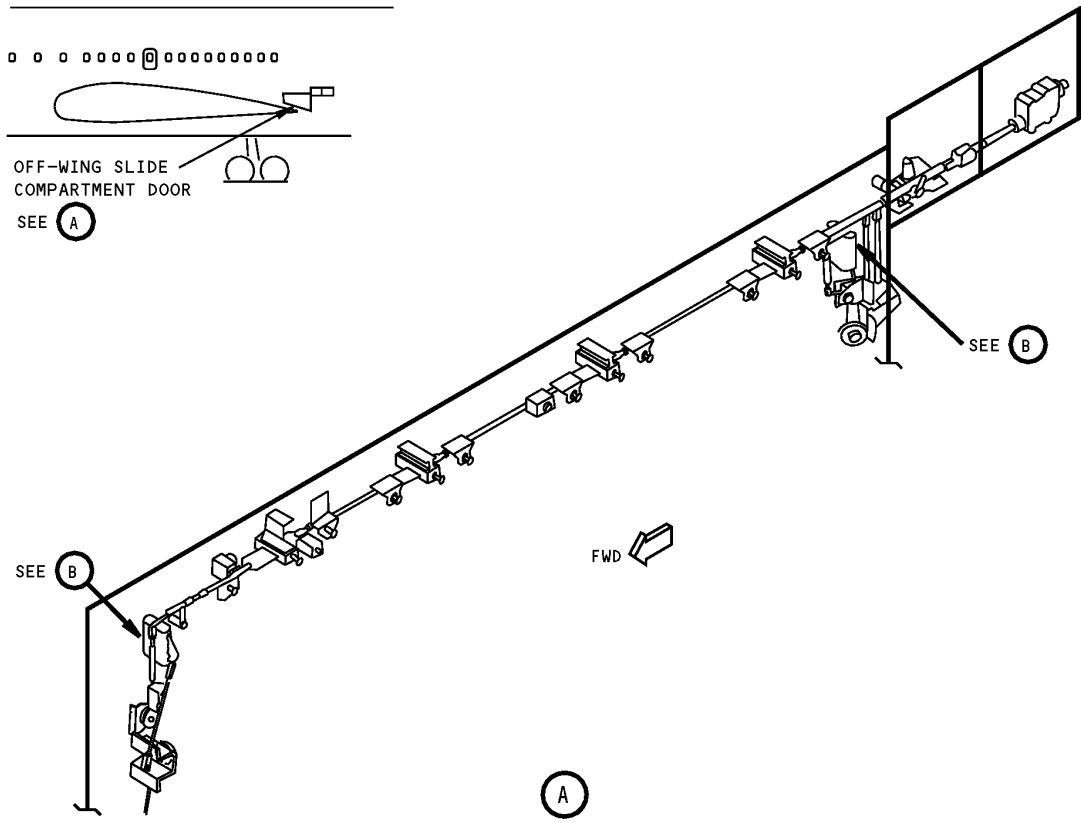

Off-Wing Escape Slide Door Opening Actuator Simulator
Figure 1 (Sheet 1 of 2)

ILLUSTRATED TOOL AND EQUIPMENT MANUAL

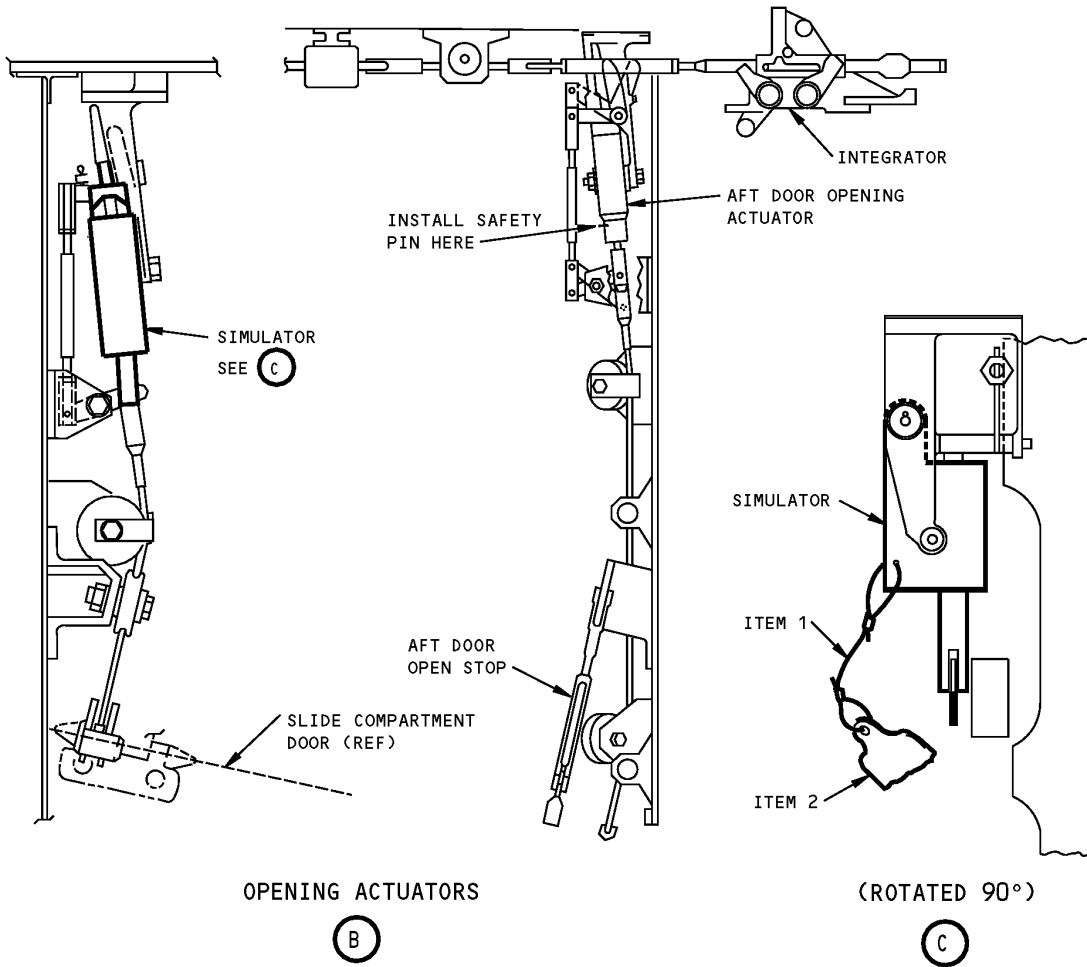

**Off-Wing Escape Slide Door Opening Actuator Simulator
Figure 1 (Sheet 2 of 2)**

REPAIRABLE/REPLACEABLE PARTS			
ITEM NO.	PART NO.	NOMENCLATURE	VENDOR CODE
1	CL-22-KA-10.0LR	LANYARD	V99862
2	NAS1756-24	WARNING STREAMER	

ILLUSTRATED TOOL AND EQUIPMENT MANUAL

PART NUMBER: A25004-1

NAME: SIMULATOR EQUIPMENT - OFF-WING ESCAPE SLIDE DOOR LATCH OPENING ACTUATOR

AIRPLANE MAINTENANCE: YES

COMPONENT MAINTENANCE: NO

USAGE & DESCRIPTION: This tool is used to functionally test the off-wing escape slide door latch opening actuator. The latch actuator is removed and the simulator installed in its place. Shop air supply provides pressure to simulate the firing pin of the door opening actuator.

WEIGHT: 8 lb (3.6 kg)

DIMENSIONS: 5 x 5 x 14 inches (127 x 127 x 356 mm)

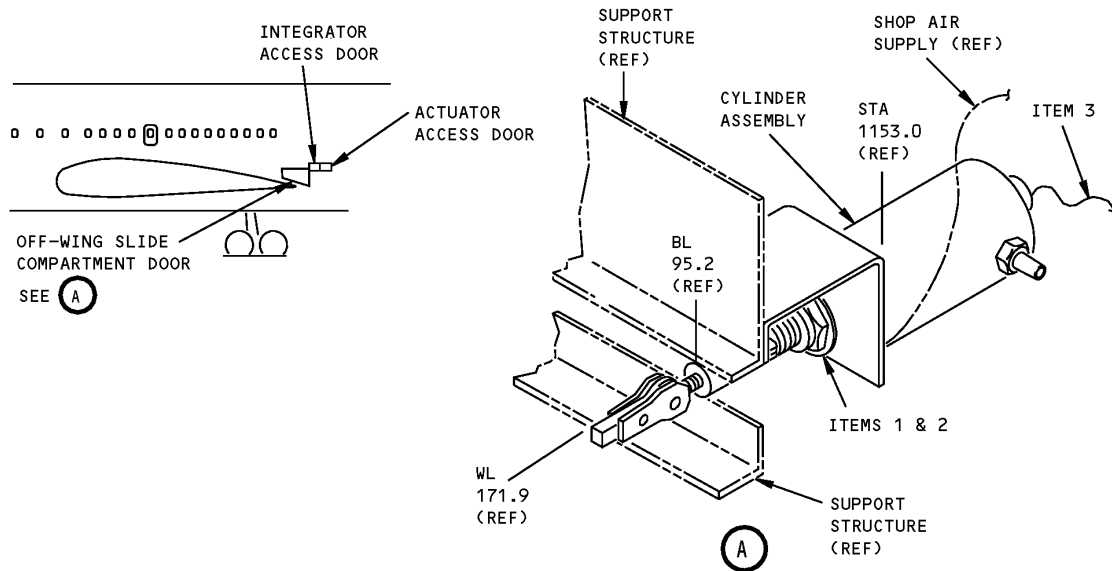

**Off-Wing Escape Slide Latch Opening Actuator Simulator Equipment
Figure 1**

REPAIRABLE/REPLACEABLE PARTS			
ITEM NO.	PART NO.	NOMENCLATURE	VENDOR CODE
1	AN316-16	NUT	
2	AN960-1616L	WASHER	
3	CL-21-KA-10.0	LANYARD	V99862

ILLUSTRATED TOOL AND EQUIPMENT MANUAL

PART NUMBER: A25005-29

NAME: SIMULATOR - GAS PRESSURE VESSEL

AIRPLANE MAINTENANCE: YES

COMPONENT MAINTENANCE: NO

USAGE & DESCRIPTION: This tool simulates the off-wing slide inflation bottle to measure trigger cable travel of the off-wing escape inflation system. The off-wing slide inflation bottle is removed and replaced by the A25005 spring-loaded simulator for testing. Refer to AMM 25-65-00 for further instructions. This tool is used on all 767 model airplanes except the freighters. This tool consists of a simulator assembly and a storage box.

WEIGHT: 25 lbs (11.3 kg)

DIMENSIONS: 9 x 9 x 28 inches (229 x 229 x 711 mm)

NOTE: A25005-29 supersedes A25005-21.
A25005-21 supersedes A25005-1.

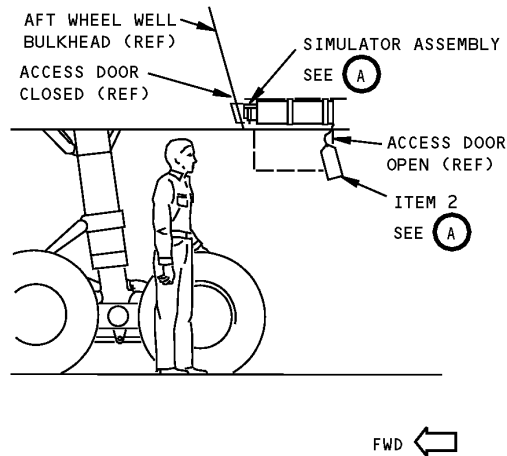

**Gas Pressure Vessel Simulator
Figure 1 (Sheet 1 of 2)**

767
ILLUSTRATED TOOL AND EQUIPMENT MANUAL

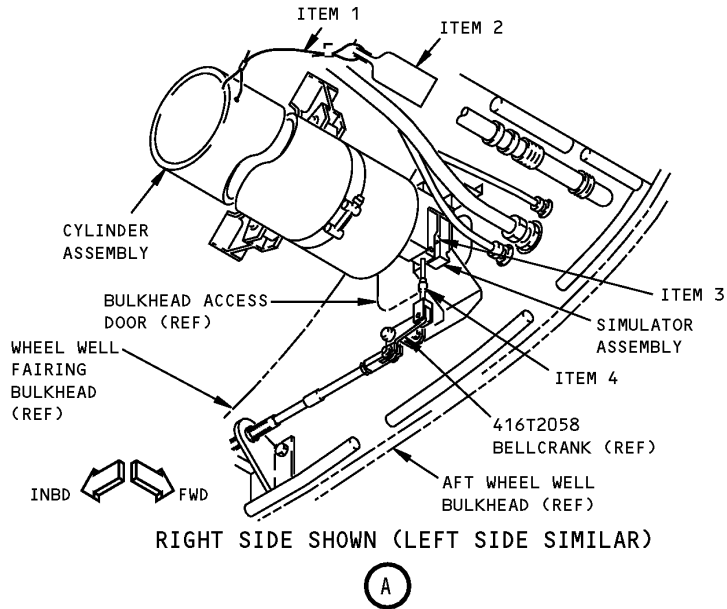

Gas Pressure Vessel Simulator
Figure 1 (Sheet 2 of 2)

REPAIRABLE/REPLACEABLE PARTS			
ITEM NO.	PART NO.	NOMENCLATURE	VENDOR CODE
1	CL-21-KA-10.0	LANYARD	V99862
2	NAS1756-24	WARNING STREAMER	
3	-7	ROLLER	
4	-3	CABLE ASSEMBLY	

ILLUSTRATED TOOL AND EQUIPMENT MANUAL

PART NUMBER: A25011-2

NAME: WRENCH - INTEGRATOR, OFF-WING ESCAPE SYSTEM

AIRPLANE MAINTENANCE: YES

COMPONENT MAINTENANCE: NO

USAGE & DESCRIPTION: This tool is used to unlatch or latch the off-wing slide compartment door during maintenance testing and removal/ installation of the escape system components. The 1/4-inch square drive wrench inserts into the integrator unlatch lever to move the latch aft or unlock the disarm system. The wrench also inserts into the latch lever to move the latch forward to lock and arm the system. This tool is used on all 767 model airplanes except the 767-400ER and freighters.

WEIGHT: 1 lb (0.45 kg)

DIMENSIONS: 1 x 5 x 5 inches (25 x 127 x 127 mm)

NOTE: A25011-2 supersedes A25011-1.

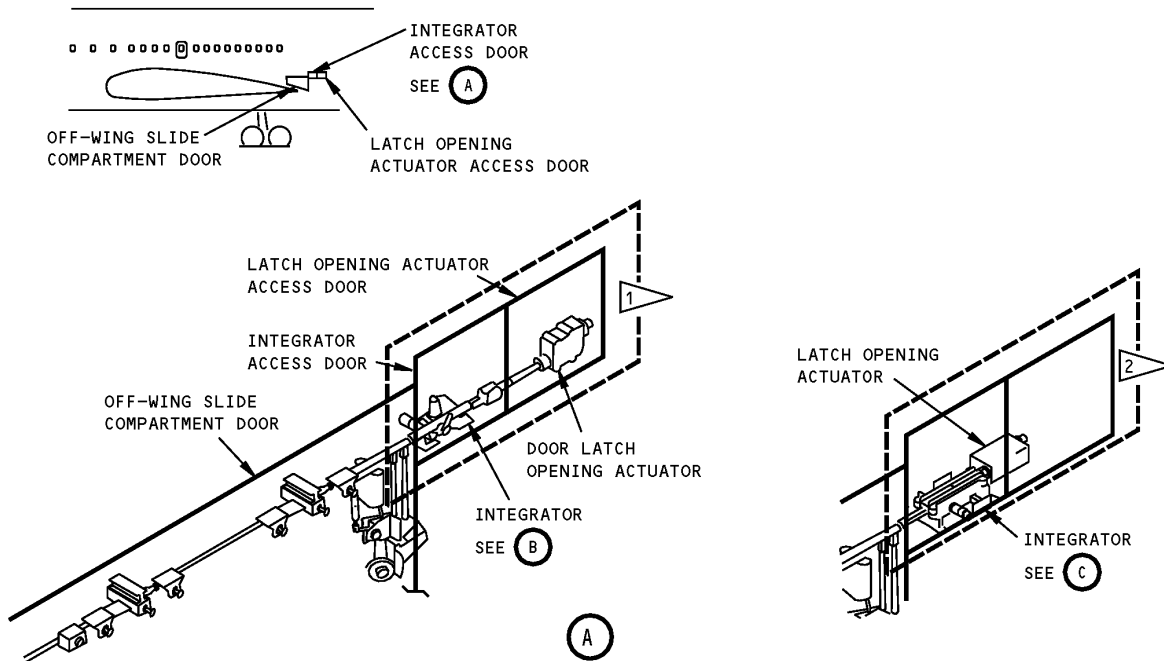

**Off-Wing Escape System Integrator Wrench
Figure 1 (Sheet 1 of 2)**

**767
ILLUSTRATED TOOL AND EQUIPMENT MANUAL**

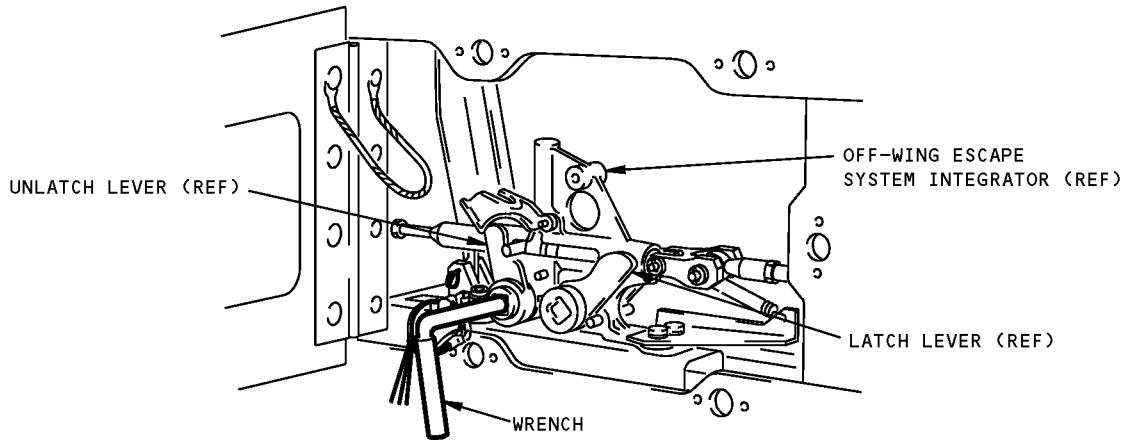

(B) 1

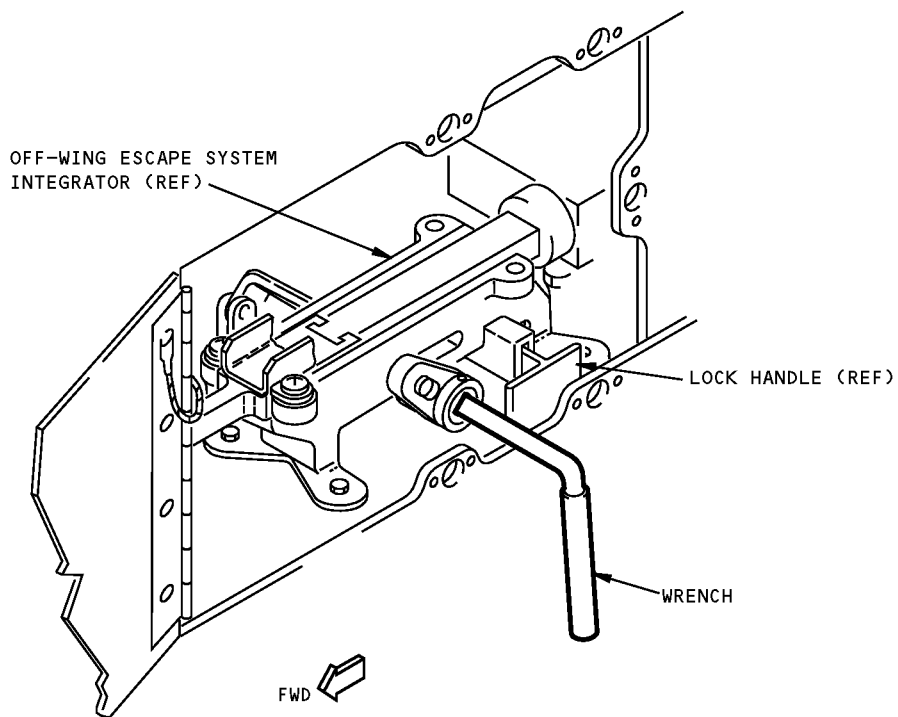

(C) 2

- 1 AIRPLANES HAVING INTEGRATORS WITH UNLATCH AND LATCH LEVERS
- 2 AIRPLANES HAVING INTEGRATORS WITH LOCK HANDLE

**Off-Wing Escape System Integrator Wrench
Figure 1 (Sheet 2 of 2)**



767

ILLUSTRATED TOOL AND EQUIPMENT MANUAL

PART NUMBER: A25012-19, -29

NAME: ELECTRICAL TEST EQUIPMENT - OFF-WING ESCAPE SLIDE SYSTEM

AIRPLANE MAINTENANCE: YES

COMPONENT MAINTENANCE: NO

USAGE & DESCRIPTION: A25012-9 electrical test equipment is used on all 767 models (except 767-400ER and freighters with built-up escape slides prior to line number 921). A25012-29 is used on all 767 models (except 767-400ER and freighters) with off-wing escape slide systems. The A25012-29 use also includes the non-built-up escape slide delivered from line number 921 and those retrofitted with the newer style slides. The A25012 electrical test equipment is used to simulate the door latch opening actuator and spoiler override actuator squibs during the off-wing escape slide test. Refer to AMM 25-65-00 for complete usage instructions.

The A25012 electrical test equipment consists of:

A25012-19		
QUANTITY	NOMENCLATURE	PART NUMBER
1	TEST BOX ASSEMBLY	A25012-2
1	CABLE ASSEMBLY	A25012-20
1	STORAGE BOX	

A25012-29		
QUANTITY	NOMENCLATURE	PART NUMBER
1	TEST BOX ASSEMBLY	A25012-30
1	CABLE ASSEMBLY	A25012-20
1	ADAPTER CABLE ASSEMBLY	A25012-31
1	STORAGE BOX	

WEIGHT: 20 lbs (9 kg)

DIMENSIONS: 12 x16 x16 inches (305 x 406 x 406 mm)

NOTE: A25012-29 replaces A25012-19 for future procurement.
A25012-19 supersedes A25012-1.

ILLUSTRATED TOOL AND EQUIPMENT MANUAL

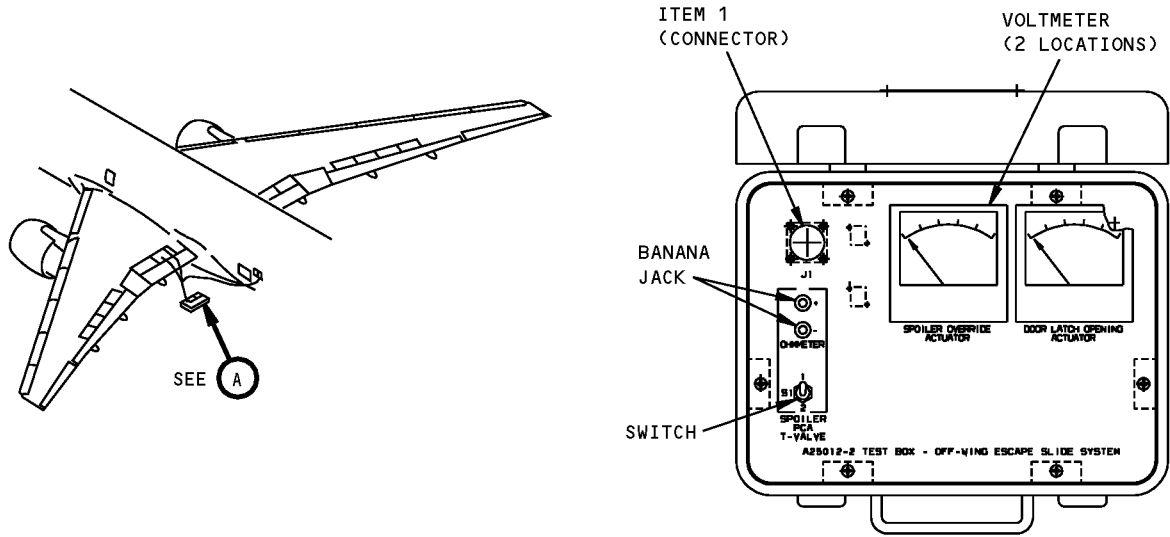

A25012-2 TEST BOX ASSEMBLY SHOWN
(A25012-30 SIMILAR)

(A)

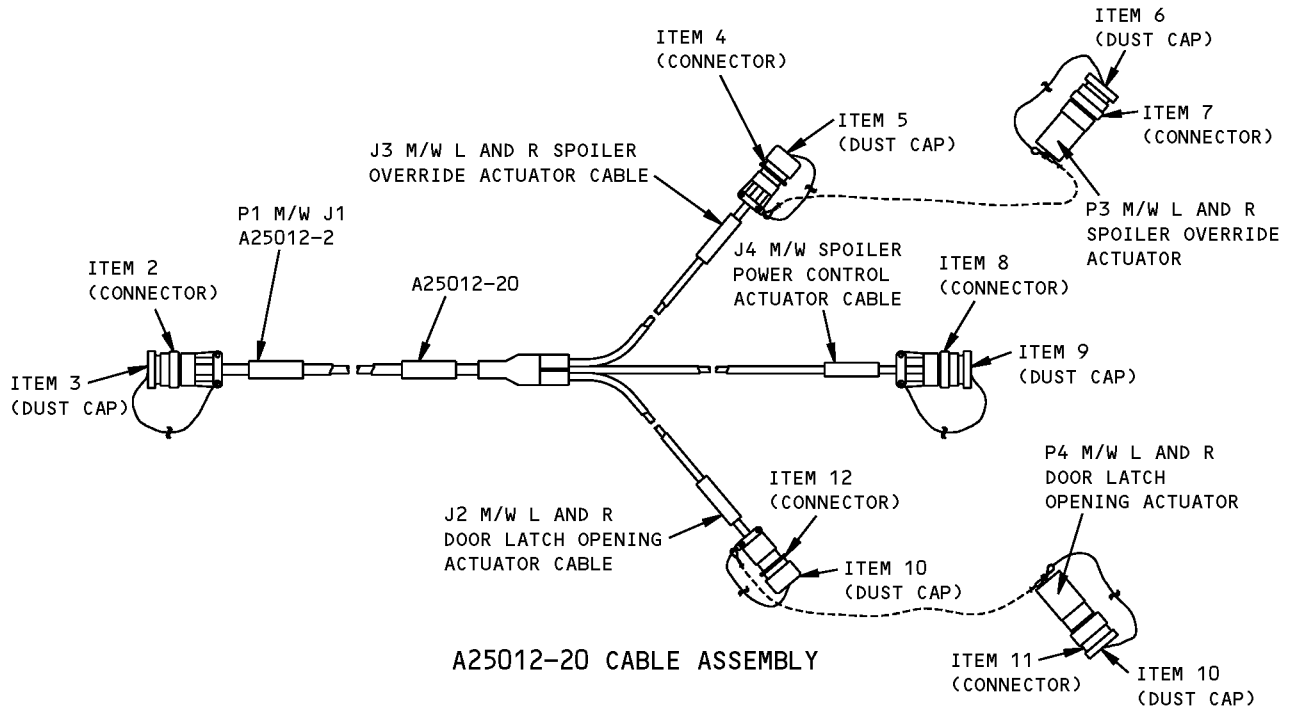

Off-Wing Escape Slide System Electrical Test Equipment
Figure 1 (Sheet 1 of 2)

ILLUSTRATED TOOL AND EQUIPMENT MANUAL

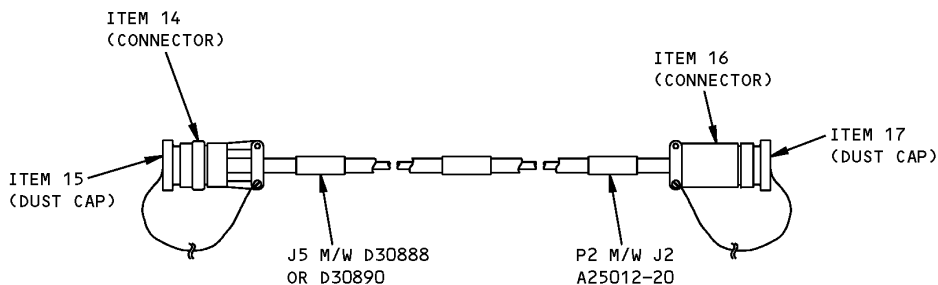

A25012-31
ADAPTER CABLE ASSEMBLY

Off-Wing Escape Slide System Electrical Test Equipment
Figure 1 (Sheet 2 of 2)

REPAIRABLE/REPLACEABLE PARTS			
ITEM NO.	PART NO.	NOMENCLATURE	VENDOR CODE
1	M83723/72R1415N	CONNECTOR	
2	M83723/75R1415N	CONNECTOR	
3	M83723/59-214AC	DUST CAP	
4	M83723/83R147N	CONNECTOR	
5	M83723/60-114AC	DUST CAP	
6	M83723/59-114AC	DUST CAP	
7	M83723/86R147N	CONNECTOR	
8	M83723/83R1610N	CONNECTOR	
9	M83723/60-116AC	DUST CAP	
10	KPT80-10CA	DUST CAP	V71468
11	KPSE06F10-6S	CONNECTOR	V71468
12	KPSE00F10-6P	CONNECTOR	V71468
13	M83723/72A803N	CONNECTOR	
14	M83723/60-208AR	DUST CAP	
15	KPSE06A10-6	CONNECTOR	V71468
16	KPT81-10CA	DUST CAP	

ILLUSTRATED TOOL AND EQUIPMENT MANUAL

PART NUMBER: A25014-29**NAME:** SIMULATOR EQUIPMENT - LATCH OPENING, OFF-WING ESCAPE SYSTEM**AIRPLANE MAINTENANCE:** YES**COMPONENT MAINTENANCE:** NO

USAGE & DESCRIPTION: The A25014-29 simulator equipment is used on all 767 model airplanes equipped with 416T2811 integrator assembly and lock handle, except the 767 freighter and 767-400ER. This tool is used to simulate the slide compartment door latch opening actuator during maintenance. Refer to AMM 25-65-00 and current A25014 drawing for further usage instructions. The tool consists of a slide assembly, an attachment assembly, an arm, a handle assembly, related hardware and a box assembly for storage.

WEIGHT: 6 lbs (2.7 kg)**DIMENSIONS:** 4 x 5 x 19 inches (102 x 127 x 483 mm)

NOTE: A25014-29 supersedes A25014-19.
A25014-19 supersedes A25014-16.
A25014-16 supersedes A25014-10.

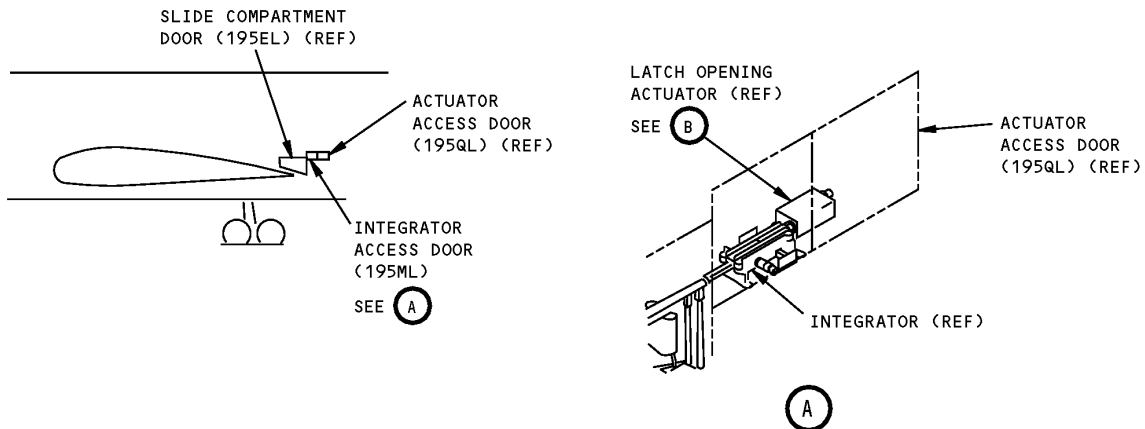

**Off-Wing Escape System Latch Opening Simulator Equipment
Figure 1 (Sheet 1 of 2)**

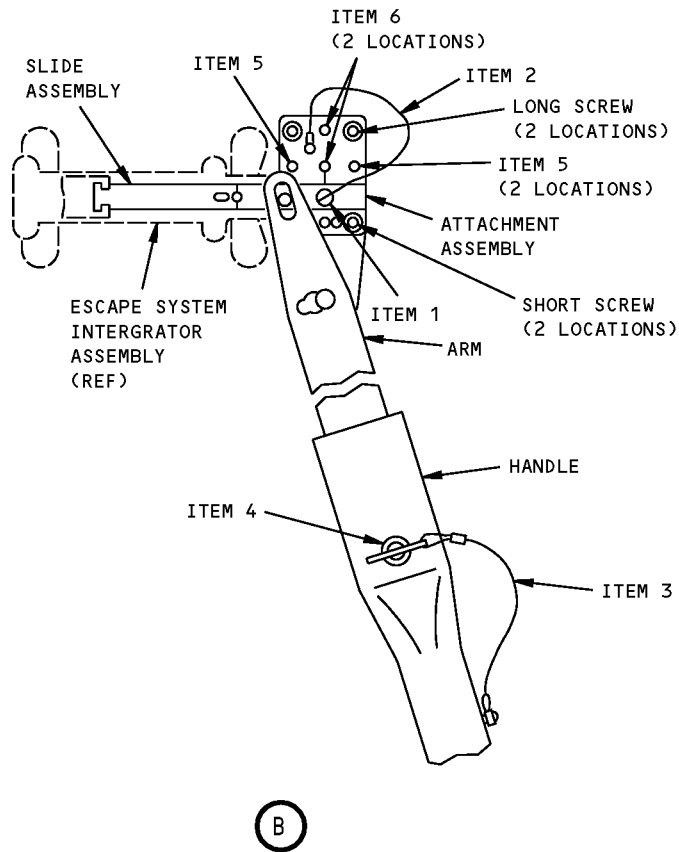

Off-Wing Escape System Latch Opening Simulator Equipment
Figure 1 (Sheet 2 of 2)



767

ILLUSTRATED TOOL AND EQUIPMENT MANUAL

REPAIRABLE/REPLACEABLE PARTS			
ITEM NO.	PART NO.	NOMENCLATURE	VENDOR CODE
1	D18-500	LOCK PIN	V00141
2	CL-23-KA-12.0L	LANYARD	V99862
3	CL-21-KA-8.0LR	LANYARD	V99862
4	CL-4-BLPR-.75	BALL LOCKPIN	V99862
5	MS16998-31	SCREW	
6	MS16998-32	SCREW	



767

ILLUSTRATED TOOL AND EQUIPMENT MANUAL

PART NUMBER: A25016-1

NAME: SAFETY EQUIPMENT - ESCAPE SYSTEM, OFF-WING

AIRPLANE MAINTENANCE: YES

COMPONENT MAINTENANCE: NO

USAGE & DESCRIPTION: This safety equipment provides shorting caps and pins when the original caps and pins on the airplane are missing. This tool is used on 767 model airplane equipped with a type III overwing emergency exit door. This tool is used on all 767 airplanes except the 767-400ER and freighters.

WEIGHT: 2 lbs (0.9 kg)

DIMENSIONS: 4 x 6 x 14 inches (102 x 152 x 356 mm)

A25016-1 SAFETY EQPT ESCAPE SYSTEM, OFF-WING		
CONTENTS	NOMENCLATURE	USED ON
MS3181-10	PROTECTIVE COVER	LATCH OPENING ACTUATOR
-2 ASSEMBLY ^{*[1]} 2174127 3092107	SAFETY PIN WARNING FLAG	DOOR OPENING ACTUATOR
350135-105	SAFETY PIN	REGULATOR, SLIDE INFLATION CYLINDER
6023149	SHORTING CAP	OVERRIDE ACTUATOR
A25016-5	PLACARD	

*[1] Each A25016-1 safety equipment contains two A25016-2 assemblies.

ILLUSTRATED TOOL AND EQUIPMENT MANUAL

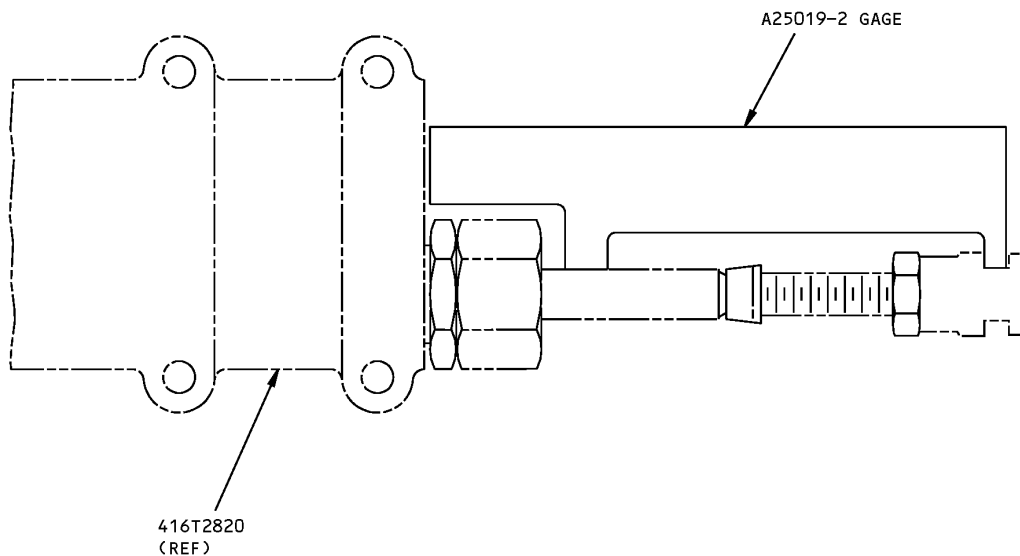
PART NUMBER: A25019-1**NAME:** GAGE - ACTUATOR, LATCH OPENING, OFF-WING ESCAPE SYSTEM**AIRPLANE MAINTENANCE:** YES**COMPONENT MAINTENANCE:** NO**USAGE & DESCRIPTION:** This tool is used for gaging the 3.30/+0.02 or -0.02 dimension on the 416T2820-1 Actuator Assembly. This tool is used on all 767 model airplanes except the 767-400ER and freighters. This tool consists of a -2 gage and a -3 box assembly.**WEIGHT:** 0.5 lb (0.2 kg)**DIMENSIONS:** 2 x 5 x 7 inches (51 x 127 x 178 mm)

Off-Wing Escape System Latch Opening Acuator Gage
Figure 1