

CHAPTER

31

**INDICATING/
RECORDING SYSTEM**



767

ILLUSTRATED TOOL AND EQUIPMENT MANUAL

CHAPTER 31
INDICATING/RECORDING SYSTEM

Subject/Page	Date	Subject/Page	Date	Subject/Page	Date
EFFECTIVE PAGES					
1	Apr 10/2008				
2	BLANK				
31-CONTENTS					
1	Apr 10/2006				
2	BLANK				
31-00-01					
1	Oct 10/2006				
2	Oct 10/2006				
31-00-02					
1	Oct 10/2006				
2	Apr 10/2006				
31-30-01					
1	Apr 10/2006				
2	Apr 10/2006				
3	Apr 10/2006				
4	BLANK				
31-50-01					
1	Oct 10/2006				
2	Apr 10/2006				
3	Apr 10/2006				
4	BLANK				
31-50-02					
1	Oct 10/2006				
2	Oct 10/2006				
31-50-03					
1	Apr 10/2006				
2	Apr 10/2006				
31-50-04					
1	Oct 10/2006				
2	Apr 10/2006				
3	Apr 10/2006				
4	BLANK				

A = Added, R = Revised, O = Overflow, D = Deleted

31-EFFECTIVE PAGES



767

ILLUSTRATED TOOL AND EQUIPMENT MANUAL

TABLE OF CONTENTS

<u>Subject</u>	<u>Title</u>	<u>Part No.</u>
31-	INDICATING/RECORDING SYSTEM	
31-00-01	TEST CABLE - WEU POWER SUPPLY	A31008-1
31-00-02	BREAKOUT BOX - POWER SUPPLY UNIT, WEU	A31010-1
31-30-01	ADAPTER CABLE - DIGITAL FLIGHT RECORDER SYSTEM TESTER	A31007-1, -30, -49, -59
31-50-01	TEST BOX - WEU POWER SUPPLY NOISE	A31005-1, -14
31-50-02	TEST BOX - WARNING ELECTRONICS UNIT (WEU) POWER SUPPLY	A31003-33, -34
31-50-03	SHORTING MODULE - MASTER WARNING PRINTED CIRCUIT ASSEMBLY	A31006-7
31-50-04	BREAKOUT BOX - WARNING ELECTRONICS UNIT POWER SUPPLY AND MONITOR	A31004-1

31-CONTENTS

Page 1
Apr 10/2006

D634T501

ILLUSTRATED TOOL AND EQUIPMENT MANUAL

PART NUMBER: A31008-1

NAME: TEST CABLE - WEU POWER SUPPLY

AIRPLANE MAINTENANCE: NO

COMPONENT MAINTENANCE: YES

USAGE & DESCRIPTION: The A31008 drawing has been transferred to BAE Systems and will no longer be revised by Boeing. The A31008 inclusion in the 767 ITEM is for information and historical purposes only.

The test cable is used to reconnect the WEU power supply after disassembly for test per CMM procedures. The cable is approximately 24 inches long with connectors and is contained in a storage box assembly.

WEIGHT: 2 lbs (0.9 kg)

DIMENSIONS: 5 x 5 x 2 inches (127 x 127 x 51 mm)

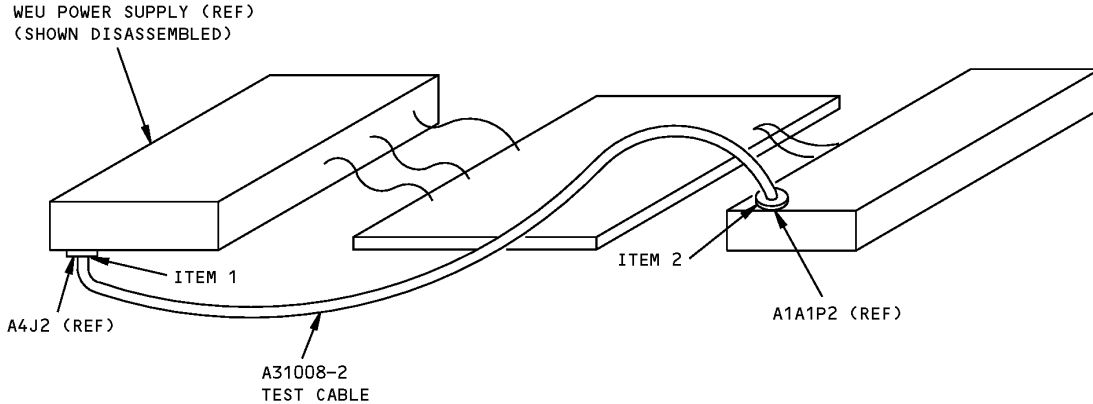

**WEU Power Supply Test Cable
Figure 1**

BREAKOUT BOX - POWER SUPPLY UNIT, WEU			
ITEM NO.	PART NO.	NOMENCLATURE	VENDOR CODE
1	DAMM15S	CONNECTOR	71468



767

ILLUSTRATED TOOL AND EQUIPMENT MANUAL

BREAKOUT BOX - POWER SUPPLY UNIT, WEU			
ITEM NO.	PART NO.	NOMENCLATURE	VENDOR CODE
2	DAMM15P	CONNECTOR	71468



767

ILLUSTRATED TOOL AND EQUIPMENT MANUAL

PART NUMBER: A31010-1

NAME: BREAKOUT BOX - POWER SUPPLY UNIT, WEU

AIRPLANE MAINTENANCE: NO

COMPONENT MAINTENANCE: YES

USAGE & DESCRIPTION: The A31010 drawing has been transferred to BAE Systems and will no longer be revised by Boeing. The A31010 inclusion in the 767 ITEM is for information and historical purposes only.

This tool is used on 767 airplanes line number 669 and up. This tool is used to bench test the warning electronic unit power supply. Refer to CMM 31-51-21 for complete usage information. This tool consists of a breakout box and a cable assembly.

WEIGHT: 5 lbs (2.3 kg)

DIMENSIONS: 5 x 11 x 17 inches (127 x 279 x 432 mm)

ILLUSTRATED TOOL AND EQUIPMENT MANUAL

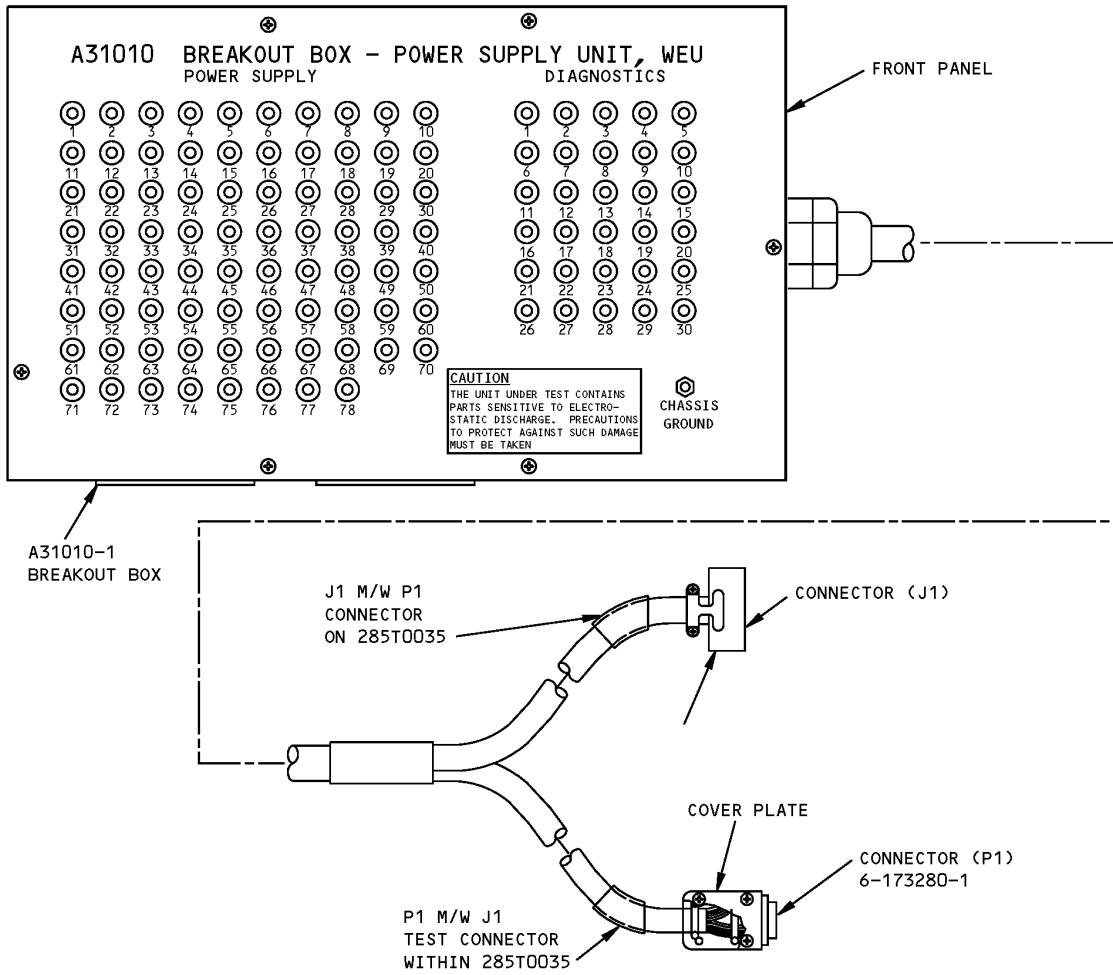

**WEU Power Supply Unit Breakout Box
 Figure 1**



767

ILLUSTRATED TOOL AND EQUIPMENT MANUAL

PART NUMBER: A31007-1, -30, -49, -59

NAME: ADAPTER CABLE - DIGITAL FLIGHT RECORDER SYSTEM TESTER

AIRPLANE MAINTENANCE: YES

COMPONENT MAINTENANCE: NO

USAGE & DESCRIPTION: This tool is an adapter cable assembly used to adapt Teledyne tester (2222786,2225302,2227295 or 2229738) or Sundstrand tester (981-6301-002) to digital flight recorder system test receptacle D1445. The A31007-1 consists of a A31007-2 cable assembly and a A31007-22 box assembly. The A31007-30 consists of a A31007-32 cable assembly and a A31007-21 box assembly. The A31007-49 consists of a A31007-35 cable assembly and a A31007-36 box assembly. The A31007-59 consists of a A31007-60 adapter assembly and a A31007-23 box assembly.

ADAPTER CABLE USAGE	
ADAPTER CABLE	TESTER
A31007-1	Teledyne Tester 2222786, 2227295, or 2225302
A31007-30	Sundstrand Tester 981-6301-002
A31007-49	Sundstrand Tester 981-6301-002
A31007-59	Teledyne Tester 2229738

DIMENSIONS: 4 x 8 x 8 inches - typical (excluding box)
12 x 12 x 4 - A31007-60 (excluding box)

NOTE: A31007-59 supersedes A31007-11.
A31007-30 supersedes A31007-16.

ILLUSTRATED TOOL AND EQUIPMENT MANUAL

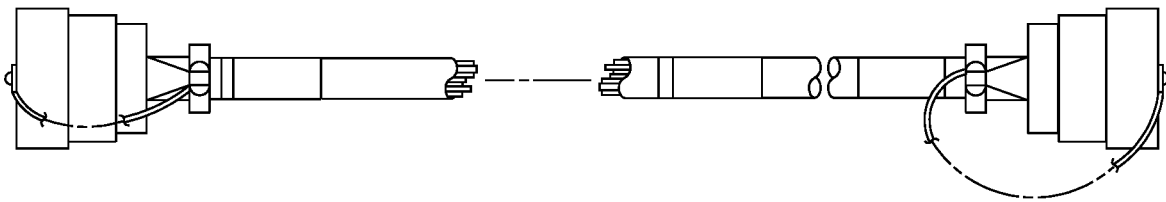
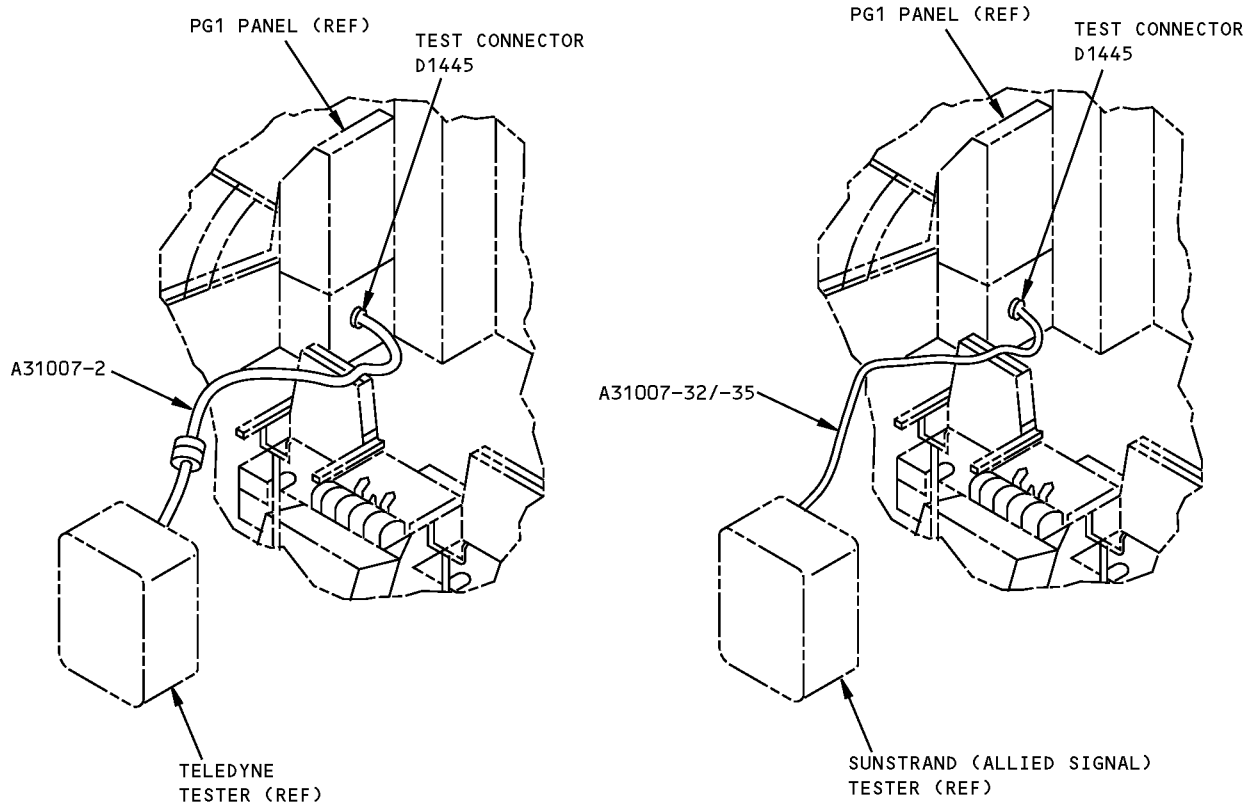

A31007-2, -32 AND -35

**Digital Flight Recorder System Tester Adapter Cable
Figure 1 (Sheet 1 of 2)**

**767
ILLUSTRATED TOOL AND EQUIPMENT MANUAL**

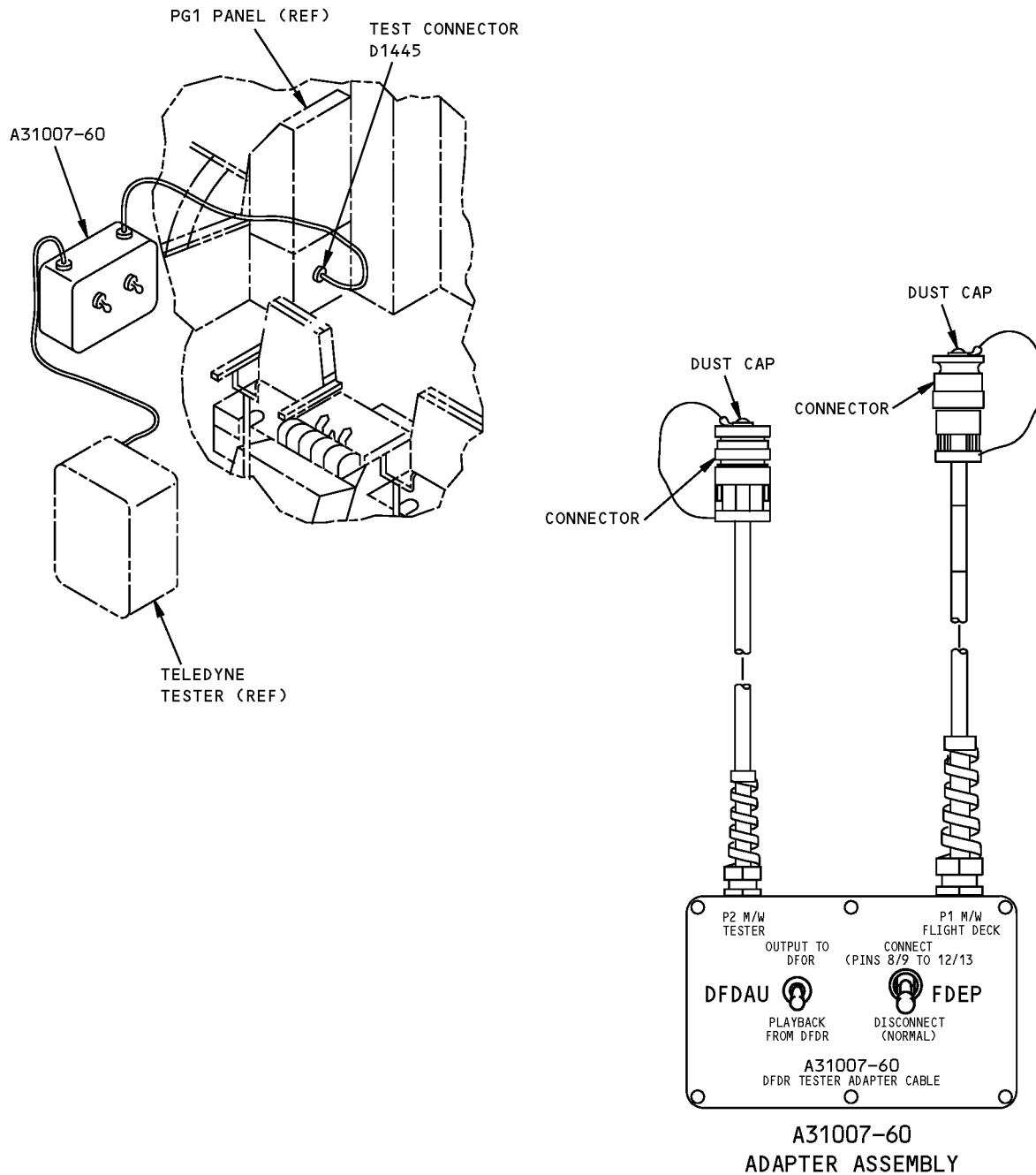

**Digital Flight Recorder System Tester Adapter Cable
Figure 1 (Sheet 2 of 2)**



767

ILLUSTRATED TOOL AND EQUIPMENT MANUAL

PART NUMBER: A31005-1, -14

NAME: TEST BOX - WEU POWER SUPPLY NOISE

AIRPLANE MAINTENANCE: NO

COMPONENT MAINTENANCE: YES

USAGE & DESCRIPTION: The A31005 drawing has been transferred to BAE Systems and will no longer be revised by Boeing. The A31005 inclusion in the 767 ITEM is for information and historical purposes only.

This test box is used to perform functional tests for noise on the Warning Electronic Unit (WEU) power supply assembly.

WEIGHT: 2 lbs (0.9 kg)

DIMENSIONS: 3 x 3 x 5 inches (76 x 76 127 mm)

NOTE: A31005-14 replaces A31005-1 for future procurement.

**767
ILLUSTRATED TOOL AND EQUIPMENT MANUAL**

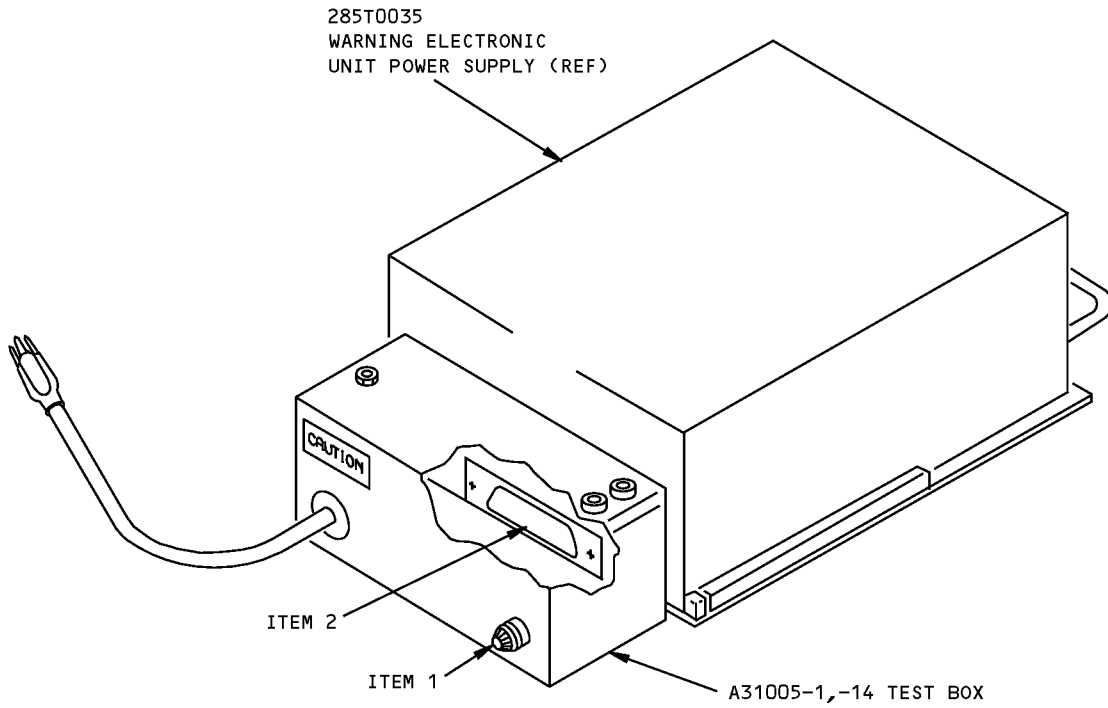

**WEU Power Supply Noise Test Box
Figure 1**



767

ILLUSTRATED TOOL AND EQUIPMENT MANUAL

REPAIRABLE/REPLACEABLE PARTS			
ITEM NO.	PART NO.	NOMENCLATURE	VENDOR CODE
1	313005	FUSE	V75915
2	DDMAM-78S	CONNECTOR	V71468

ILLUSTRATED TOOL AND EQUIPMENT MANUAL

PART NUMBER: A31003-33, -34

NAME: TEST BOX - WARNING ELECTRONICS UNIT (WEU) POWER SUPPLY

AIRPLANE MAINTENANCE: NO

COMPONENT MAINTENANCE: YES

USAGE & DESCRIPTION: The A31003 drawing has been transferred to BAE Systems and will no longer be revised by Boeing. The A31003 inclusion in the 767 ITEM is for information and historical purposes only.

This tool is a test box used to functionally test the WEU power supply unit and the monitor printed circuit assembly. The -33 is on all 767 except airplanes equipped with the WEA Power Supply 285T0035 and on.

WEIGHT: 9 lbs (4 kg)

DIMENSIONS: 5 x 11 x 17 inches (127 x 279 x 432 mm)

NOTE: A31003-34 supersedes A31 003-1, -29
 A31003-33 supersedes A31003-25
 A31003-29 replaces A31003-1, -25 for future procurement.

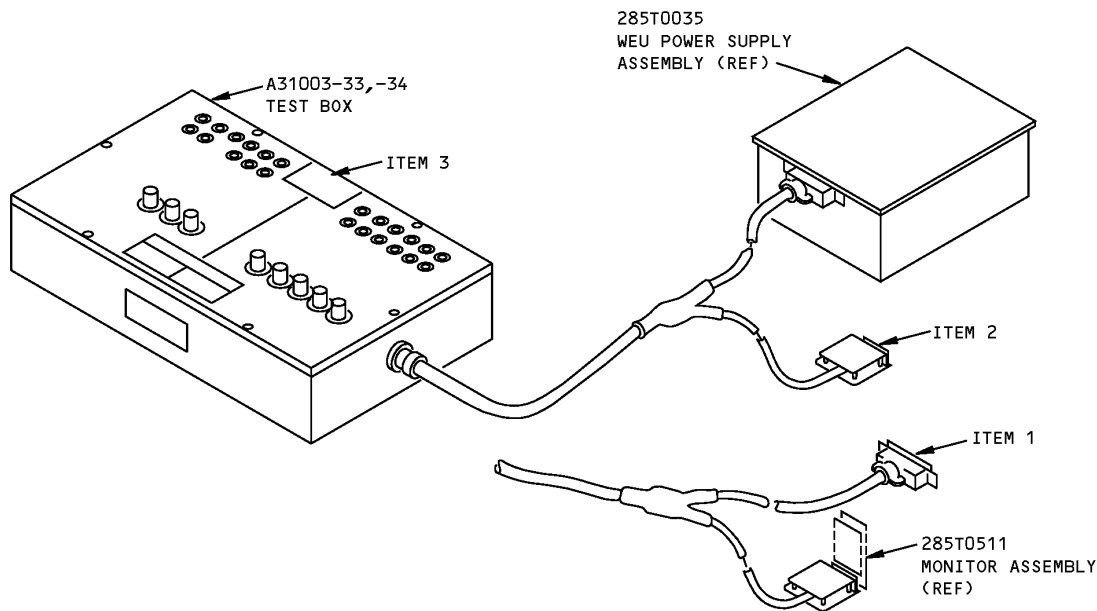

**WEU Power Supply Test Box
 Figure 1**



767

ILLUSTRATED TOOL AND EQUIPMENT MANUAL

REPAIRABLE/REPLACEABLE PARTS			
ITEM NO.	PART NO.	NOMENCLATURE	VENDOR CODE
1	DDMAM-78S	CONNECTOR	V71468
2	MDM25PL39B	CONNECTOR	V71468
3	312003	FUSE	V75915

ILLUSTRATED TOOL AND EQUIPMENT MANUAL

PART NUMBER: A31006-7

NAME: SHORTING MODULE - MASTER WARNING PRINTED CIRCUIT ASSEMBLY

AIRPLANE MAINTENANCE: YES

COMPONENT MAINTENANCE: NO

USAGE & DESCRIPTION: This tool replaces the master warning printed circuit assembly which places a ground on the output voltage circuit of the warning electronic unit power supply. The short circuit to ground causes a fault output signal from the warning electronic power supply. The tool consists of printed circuit assembly with a short circuit printed wiring pattern.

WEIGHT: 1 lb (0.45 kg)

DIMENSIONS: 1 x 6 x 8 inches (25 x 152 x 203 mm)

NOTE: The A31006-7 tool supersedes the A31006-5.

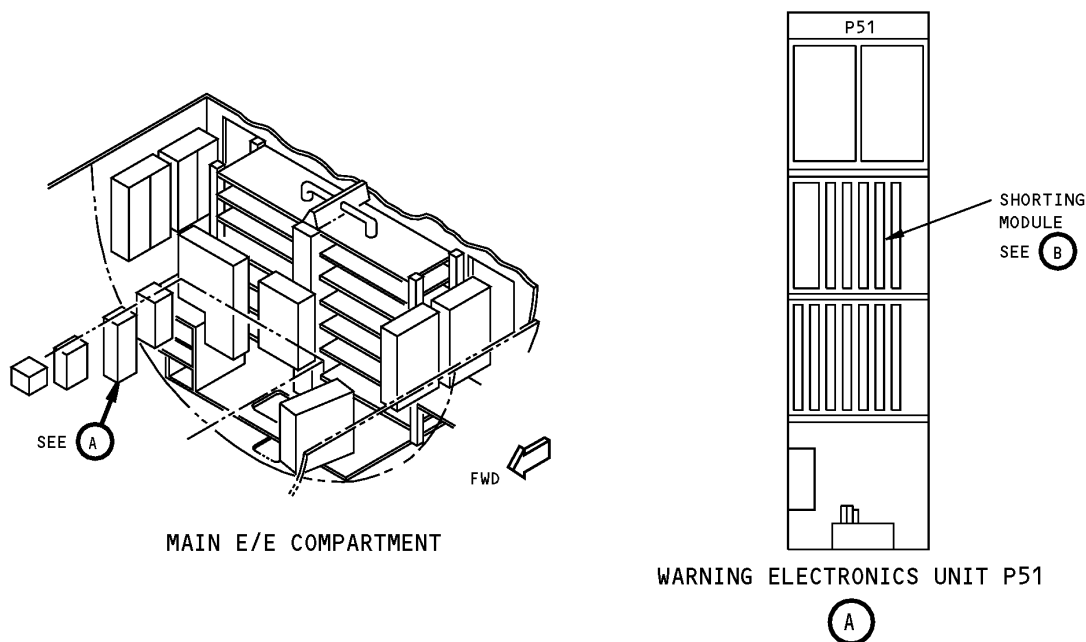

**Master Warning Printed Circuit Assembly Shorting Module
Figure 1 (Sheet 1 of 2)**

767
ILLUSTRATED TOOL AND EQUIPMENT MANUAL

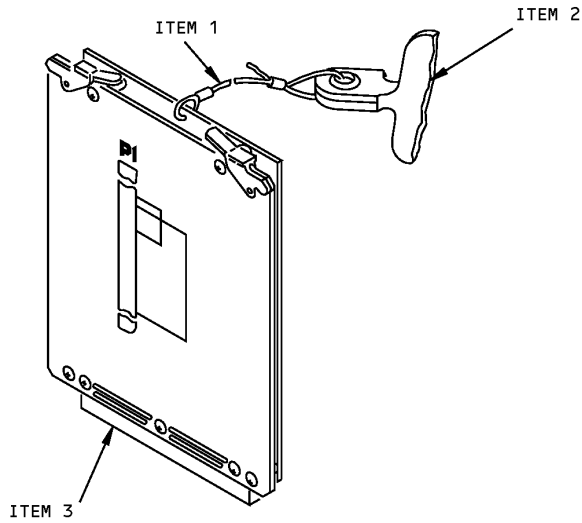

SHORTING MODULE ASSY

B

Master Warning Printed Circuit Assembly Shorting Module
Figure 1 (Sheet 2 of 2)

REPAIRABLE/REPLACEABLE PARTS			
ITEM NO.	PART NO.	NOMENCLATURE	VENDOR CODE
1	CL-22-KA-10.0-LR	CABLE ASSY	V94882
2	NAS1756-24	STREAMER - WARNING	
3	300044-001	CONNECTOR	V03877



767

ILLUSTRATED TOOL AND EQUIPMENT MANUAL

PART NUMBER: A31004-1

NAME: BREAKOUT BOX - WARNING ELECTRONICS UNIT POWER SUPPLY AND MONITOR

AIRPLANE MAINTENANCE: NO

COMPONENT MAINTENANCE: YES

USAGE & DESCRIPTION: The A31004 drawing has been transferred to BAE Systems and will no longer be revised by Boeing. The A31004 inclusion in the 767 ITEM is for information and historical purposes only.

This tool is used to perform continuity tests on the warning electronics unit power supply and monitor assembly. The tool consists of a breakout box and cable assembly.

WEIGHT: 5 lbs (2.3 kg)

DIMENSIONS: 5 x 11 x 17 inches (127 x 279 x 432 mm)

ILLUSTRATED TOOL AND EQUIPMENT MANUAL

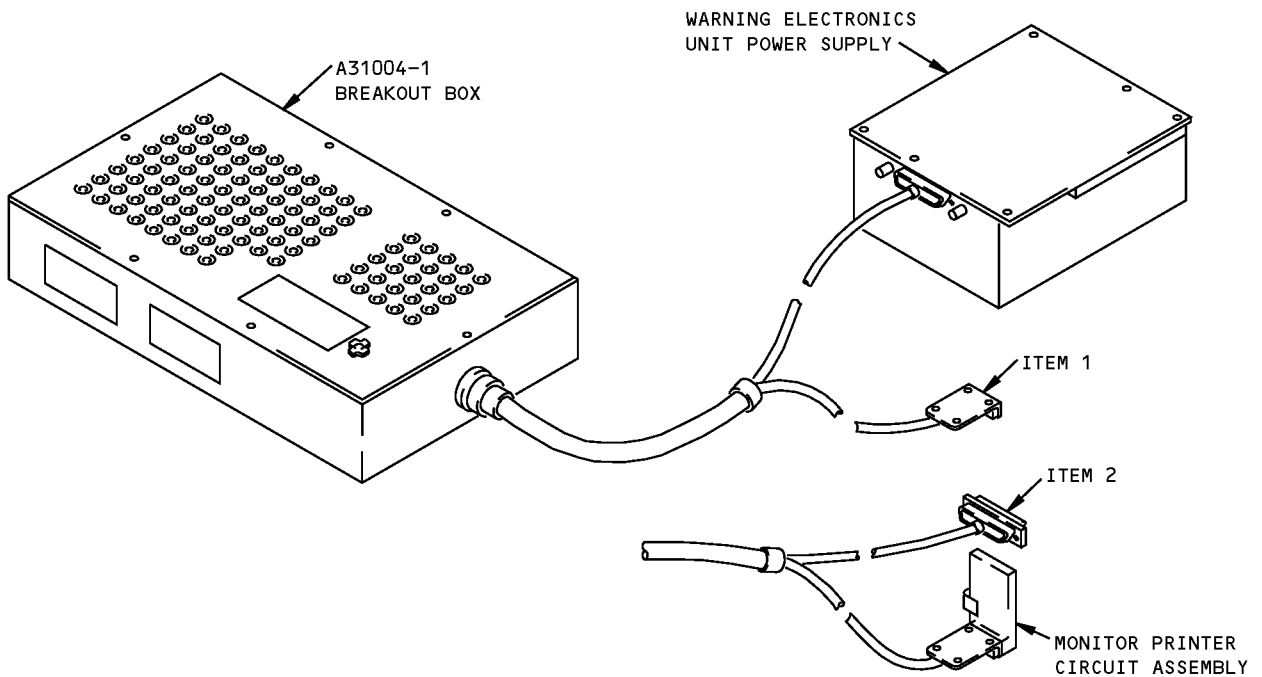

**Warning Electronics Unit Power Supply and Monitor Breakout Box
Figure 1**



767

ILLUSTRATED TOOL AND EQUIPMENT MANUAL

REPAIRABLE/REPLACEABLE PARTS			
ITEM NO.	PART NO.	NOMENCLATURE	VENDOR CODE
1	MDM-25PL39B	CONNECTOR J1	
2	DDMAM-78S	CONNECTOR P1	