

CHAPTER

36

PNEUMATIC POWER



767

ILLUSTRATED TOOL AND EQUIPMENT MANUAL

CHAPTER 36
PNEUMATIC POWER

Subject/Page	Date	Subject/Page	Date	Subject/Page	Date
EFFECTIVE PAGES		36-10-05 (cont)		36-10-17	
1	Apr 10/2008	2	Apr 10/2006	1	Apr 10/2006
2	BLANK	36-10-06		2	Apr 10/2006
36-CONTENTS		1	Apr 10/2006	36-10-18	
1	Apr 10/2006	2	Apr 10/2006	1	Apr 10/2006
2	BLANK	3	Apr 10/2006	2	Apr 10/2006
36-00-01		4	BLANK	36-10-19	
1	Apr 10/2006	36-10-07		1	Apr 10/2006
2	Apr 10/2006	1	Apr 10/2006	2	Apr 10/2006
36-00-02		2	Apr 10/2006	3	Apr 10/2006
1	Apr 10/2006	36-10-08		4	BLANK
2	Apr 10/2006	1	Apr 10/2006	36-10-20	
3	Apr 10/2006	2	Apr 10/2006	1	Apr 10/2006
4	BLANK	36-10-09		2	Apr 10/2006
36-00-03		1	Apr 10/2006	3	Apr 10/2006
1	Apr 10/2006	2	Apr 10/2006	4	Apr 10/2006
2	Apr 10/2006	36-10-10		5	Apr 10/2006
3	Apr 10/2006	1	Apr 10/2006	6	BLANK
4	BLANK	2	Apr 10/2006	36-10-21	
36-00-04		36-10-11		1	Apr 10/2006
1	Apr 10/2007	1	Apr 10/2006	2	Apr 10/2006
2	Apr 10/2007	2	Apr 10/2006	3	Apr 10/2006
3	Apr 10/2007	36-10-12		4	BLANK
4	Apr 10/2007	1	Apr 10/2006		
36-10-01		2	BLANK		
1	Apr 10/2006	36-10-13			
2	BLANK	1	Apr 10/2006		
36-10-02		2	Apr 10/2006		
1	Apr 10/2006	36-10-14			
2	Apr 10/2006	1	Apr 10/2006		
3	Apr 10/2006	2	Apr 10/2006		
4	Apr 10/2006	36-10-15			
36-10-03		1	Apr 10/2006		
1	Apr 10/2006	2	Apr 10/2006		
2	Apr 10/2006	3	Apr 10/2006		
36-10-04		4	BLANK		
1	Apr 10/2006	36-10-16			
2	Apr 10/2006	1	Apr 10/2006		
36-10-05		2	Apr 10/2006		
1	Apr 10/2006				

A = Added, R = Revised, O = Overflow, D = Deleted

36-EFFECTIVE PAGES

Page 1
Apr 10/2008

D634T501



767

ILLUSTRATED TOOL AND EQUIPMENT MANUAL

TABLE OF CONTENTS

<u>Subject</u>	<u>Title</u>	<u>Part No.</u>
36-	PNEUMATIC POWER	
36-00-01	DUMMY CHECK VALVE - INTERMEDIATE PRESSURE (IP) PNEUMATIC SYSTEM, DISPATCH EQUIPMENT	A36006-1
36-00-02	TEST EQUIPMENT - INTERMEDIATE PRESSURE (IP) DUMMY CHECK VALVE	A36007-1
36-00-03	TEST EQUIPMENT - PNEUMATIC SYSTEM HEALTH CHECK	G36035-1, -36
36-00-04	ADAPTER CABLE - BITE MODULE, AIR SUPPLY SYSTEM	A36021-1
36-10-02	REMOVAL/INSTALLATION EQUIPMENT - ENGINE PRECOOLER	A36001-1, -24, -44, -45
36-10-03	PLUG SET - PNEUMATIC DUCTS HYDROSTATIC PRESSURE TEST	A36003-173
36-10-04	INSTALLATION EQUIPMENT - CF6-80C2B BALL JOINT	A36004-15, -20
36-10-05	PLUG EQUIPMENT - DUCT TEST	B36005-2, -4
36-10-06	HOLD OPEN EQUIPMENT - PRESSURE REGULATING AND SHUT-OFF VALVE (PRSOV)	A36005-1, -15
36-10-07	PRESSURE TEST EQUIPMENT - DUCT ASSEMBLY	A36010-1
36-10-08	PRESSURE TEST EQUIPMENT - DUCT ASSEMBLY	A36011-1
36-10-09	PRESSURE TEST EQUIPMENT - DUCT ASSEMBLY	A36012-1
36-10-10	PRESSURE TEST EQUIPMENT - DUCT ASSEMBLY	A36013-1
36-10-11	PRESSURE TEST EQUIPMENT - DUCT ASSEMBLY	A36008-1
36-10-12	PRESSURE TEST PLUG - DUCT ASSEMBLY	A36016-1
36-10-13	PRESSURE TEST EQUIPMENT - DUCT ASSEMBLY	A36009-1
36-10-14	PRESSURE TEST EQUIPMENT - DUCT ASSEMBLY	J36010-1
36-10-15	PRESSURE TEST EQUIPMENT - DUCT ASSEMBLY	A36014-1
36-10-16	PRESSURE TEST EQUIPMENT - DUCT ASSEMBLY	A36015-1
36-10-17	PLUG - DUCT, PROOF PRESSURE TEST	A36017-1
36-10-18	PLUG EQUIPMENT - DUCT, PROOF PRESSURE TEST	A36018-1
36-10-19	PLUG EQUIPMENT - DUCT, PROOF PRESSURE TEST	A36019-1
36-10-20	PLUG EQUIPMENT - DUCTS, PROOF PRESSURE TEST	A36020-1
36-10-21	REMOVAL/INSTALLATION EQUIPMENT - RB211 PRECOOLER	A36022-1

36-CONTENTS



767

ILLUSTRATED TOOL AND EQUIPMENT MANUAL

PART NUMBER: A36006-1

NAME: DUMMY CHECK VALVE - INTERMEDIATE PRESSURE (IP) PNEUMATIC SYSTEM, DISPATCH EQUIPMENT

AIRPLANE MAINTENANCE: YES

COMPONENT MAINTENANCE: NO

USAGE & DESCRIPTION: The A36006-1 dummy check valve is used on 767 airplanes equipped with General Electric CF6-80A/A2 or Pratt and Whitney JT9D Series Engines. A36006 is a dispatch deviation tool, used in place of the intermediate pressure check valve (located in the 8th-Stage bleed air system). A36006 blocks the low pressure bleed duct. A36006 is used during conditions of an inoperative valve, a blown precooler or a blown duct condition. Refer to the 767 Dispatch Deviations Guide, 2-36-12-1.2 for complete usage instructions. A36006-1 consists of an A36006-2 dummy check valve contained in a storage box.

Functional test procedures for the A36006-1 dummy check valve are included in the current A36006 drawing. The functional test equipment also requires use of the A36007-1 test equipment.

WEIGHT: 8 lbs. (3.6 kg)

DIMENSIONS: 4 x 8 inches (102 x 203 mm)

**767
ILLUSTRATED TOOL AND EQUIPMENT MANUAL**

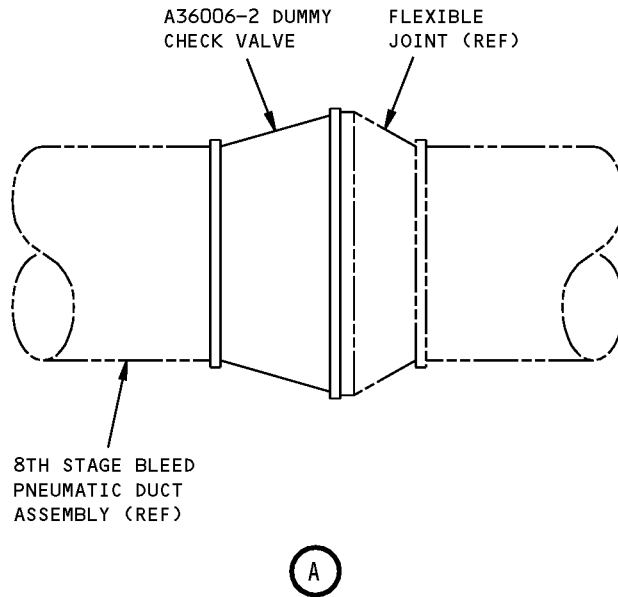
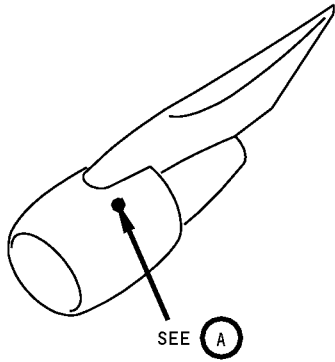

**Dispatch Equipment, Ip Pneumatic System, Dummy Check Valve
Figure 1**



767

ILLUSTRATED TOOL AND EQUIPMENT MANUAL

PART NUMBER: A36007-1

NAME: TEST EQUIPMENT - INTERMEDIATE PRESSURE (IP) DUMMY CHECK VALVE

AIRPLANE MAINTENANCE: YES

COMPONENT MAINTENANCE: NO

USAGE & DESCRIPTION: The A36007-1 test equipment is used on 767 airplanes equipped with General Electric CF6-80A/A2 or Pratt and Whitney JT9D Series Engines. The A36007-1 test equipment is used to perform burst pressure test, proof pressure test and external air leak test on the A36006-1 dummy check valve. Refer to the current A36006 and A36007 drawings for complete usage instructions. A36007-1 consists of:

A36007-1		
QUANTITY	NOMENCLATURE	PART NUMBER
1	SAFETY TEST CHAMBER ASSEMBLY	A36007-2
1	LARGE TEST PLUG ASSEMBLY	A36007-3
1	SMALL TEST PLUG ASSEMBLY	A36007-4
1	BLEED/PRESSURE RELEASE VALVE ASSEMBLY	A36007-5
1	HAND PUMP ASSEMBLY	A36007-6
1	AIR METERING ASSEMBLY	A36007-7
1	HOSE LINK ASSEMBLY	A36007-8
1	CLAMP	2320-750
1	CLAMP	2703-550
1	E-SEAL	2873-750
1	E-SEAL	2873-550
1	1 GALLON ENERPAC HYDRAULIC OIL	HF-101
1	STORAGE BOX	

WEIGHT: 50 lbs. (23 kg)

DIMENSIONS: 16 x 28 x 30 inches (406 x 711 x 762 mm)

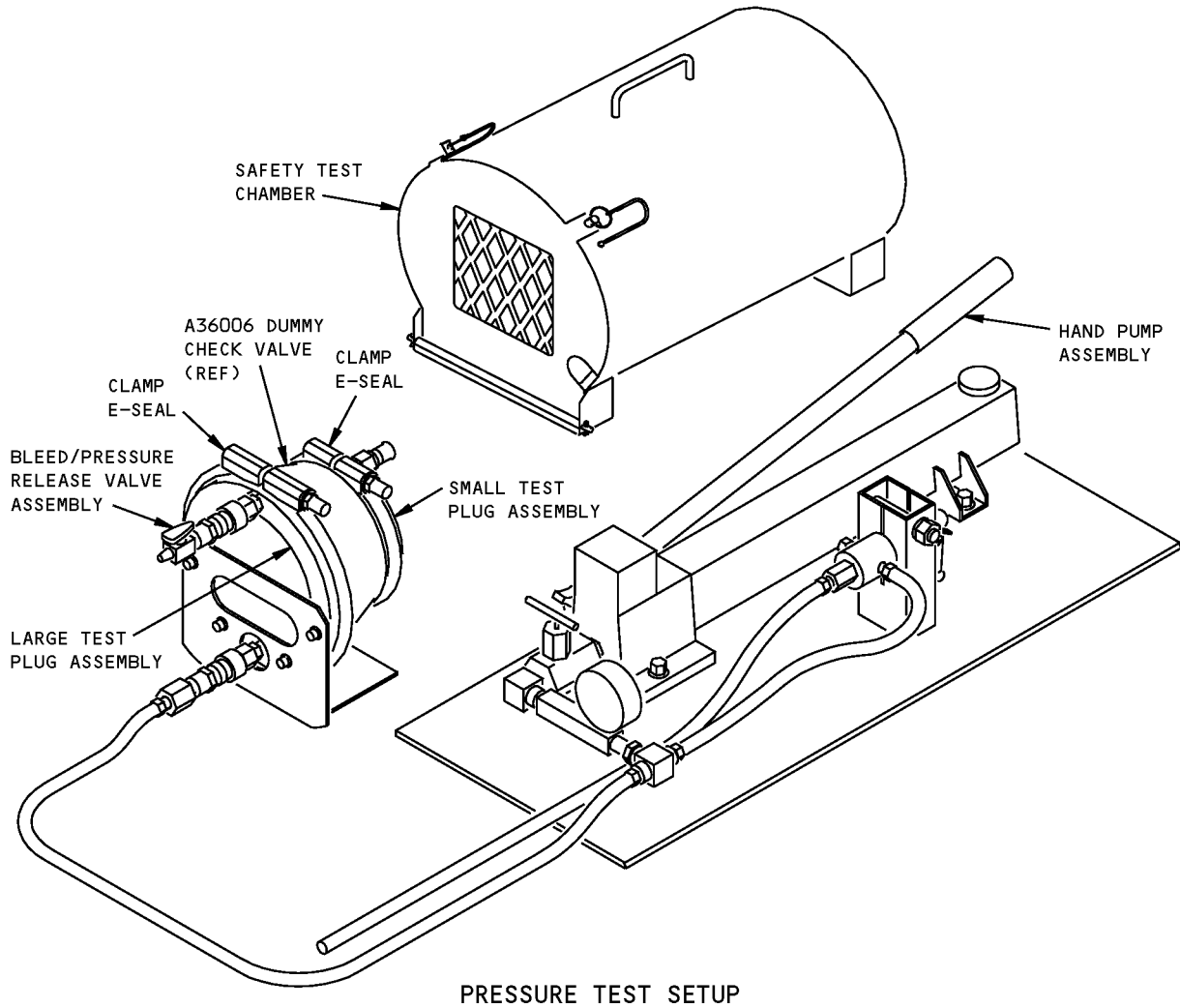

**Intermediate Pressure Dummy Check Valve Test Equipment
Figure 1 (Sheet 1 of 2)**

**767
ILLUSTRATED TOOL AND EQUIPMENT MANUAL**

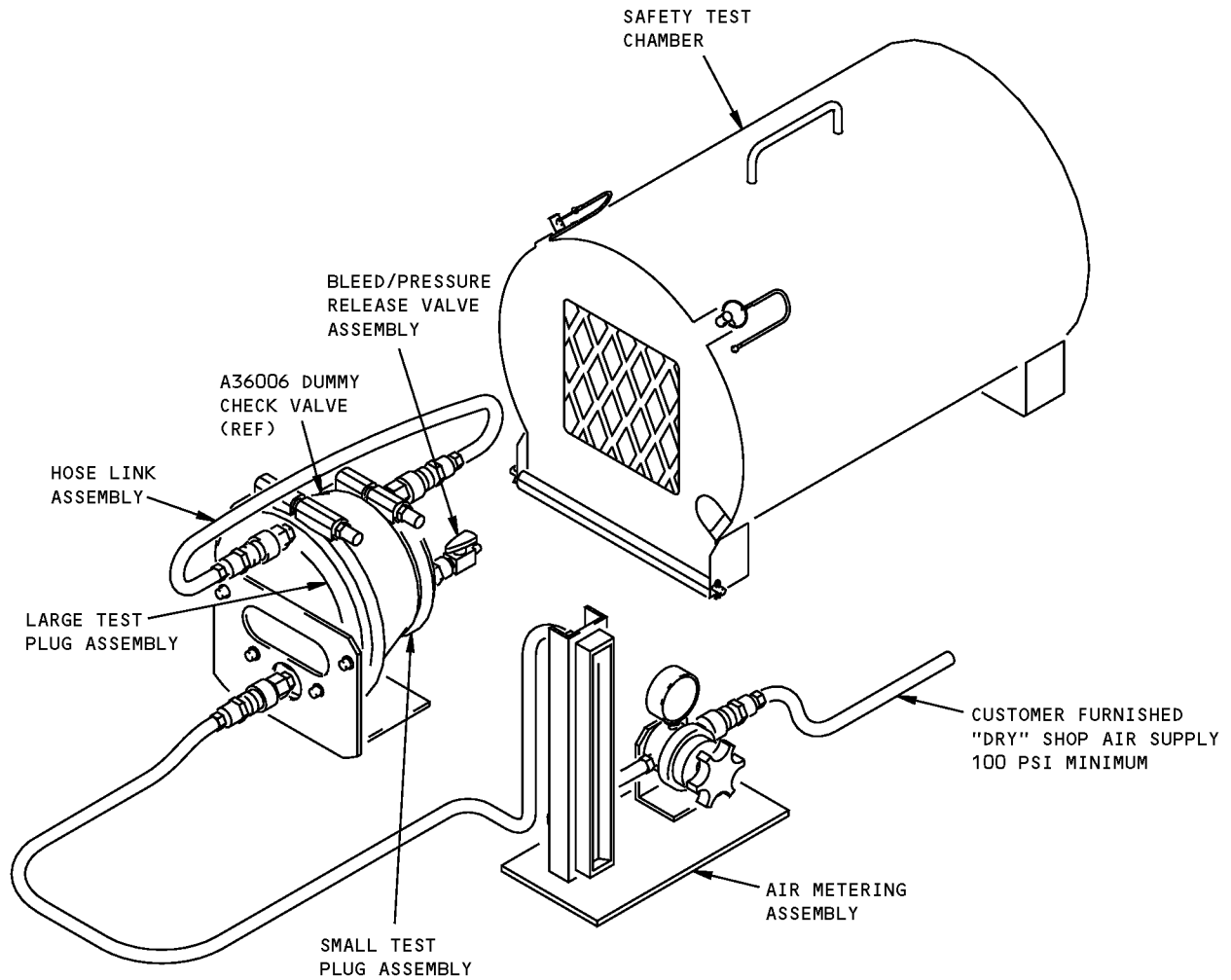

EXTERNAL AIR LEAK TEST SETUP

**Intermediate Pressure Dummy Check Valve Test Equipment
Figure 1 (Sheet 2 of 2)**



767

ILLUSTRATED TOOL AND EQUIPMENT MANUAL

PART NUMBER: G36035-1, -36

NAME: TEST EQUIPMENT - PNEUMATIC SYSTEM HEALTH CHECK

AIRPLANE MAINTENANCE: YES

COMPONENT MAINTENANCE: NO

USAGE & DESCRIPTION: The G36035-1 and -36 test equipment are used on 767 airplanes equipped with PW4000 and GE CF6-80C2 engines. The G36035 test equipment consists of a G36035-1 test box and a G36035-36 GE and PW fittings box. G36035 is used to perform the pneumatic system health check. Refer to AMM 36-00-26 for CF6-80C2 engines complete usage instructions. Refer to AMM 36-00-21, AMM 36-00-22, AMM 36-00-24, AMM 36-11-07, AMM 36-11-07 and AMM 36-11-18 for PW4000 complete usage instructions. G36035-1 consists of a test box. G36035-36 GE and PW fittings box consists of:

G36035-36		
QUANTITY	NOMENCLATURE	PART NUMBER
1	HOSE ASSEMBLY	G36035-11
1	HOSE ASSEMBLY	G36035-12
1	HOSE ASSEMBLY	G36035-13
1	FILTER FITTING ASSEMBLY	G36035-37
1	ACTUATOR FITTING ASSEMBLY	G36035-38
1	45 DEGREE FITTING ASSEMBLY	G36035-18
1	STRAIGHT FITTING ASSEMBLY	G36035-21
1	TEE FITTING ASSEMBLY	G36035-23
1	90 DEGREE FITTING ASSEMBLY	G36035-25
1	SHORT FITTING ASSEMBLY	G36035-30
1	ADAPTER ASSEMBLY	G36035-32
1	PRSOV FITTING ASSEMBLY	G36035-34
1	TEE FITTING ASSEMBLY	G36035-40
1	STORAGE BOX	

WEIGHT: G36035-1 - 35 lbs (16 kg)
G36035-36 - 15 lbs (7 kg)

DIMENSIONS: G36035-1 - 8 x 17 x 21 inches (203 x 432 x 533 mm)
G36035-36 - 8 x 17 x 21 inches (203 x 432 x 533 mm)

NOTE: G36035-36 supersedes G36035-2.

ILLUSTRATED TOOL AND EQUIPMENT MANUAL

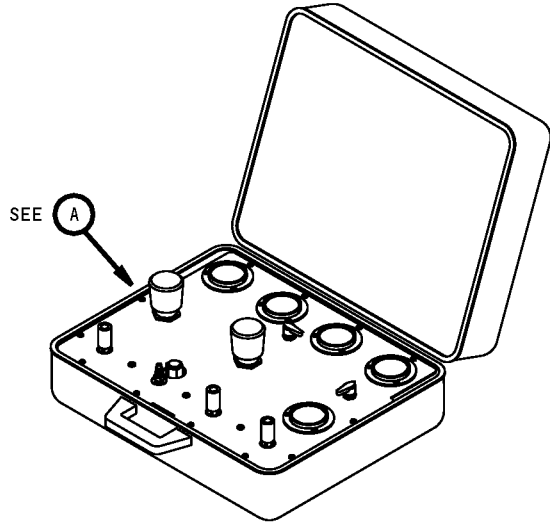

G36035-1 TEST BOX

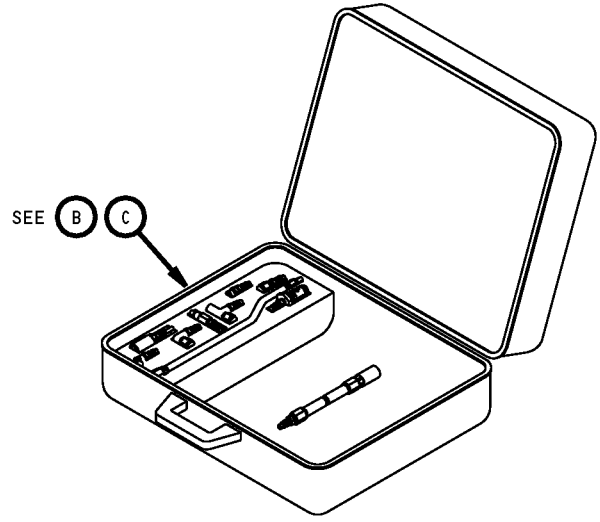

G36035-36 GE AND PW FITTINGS BOX

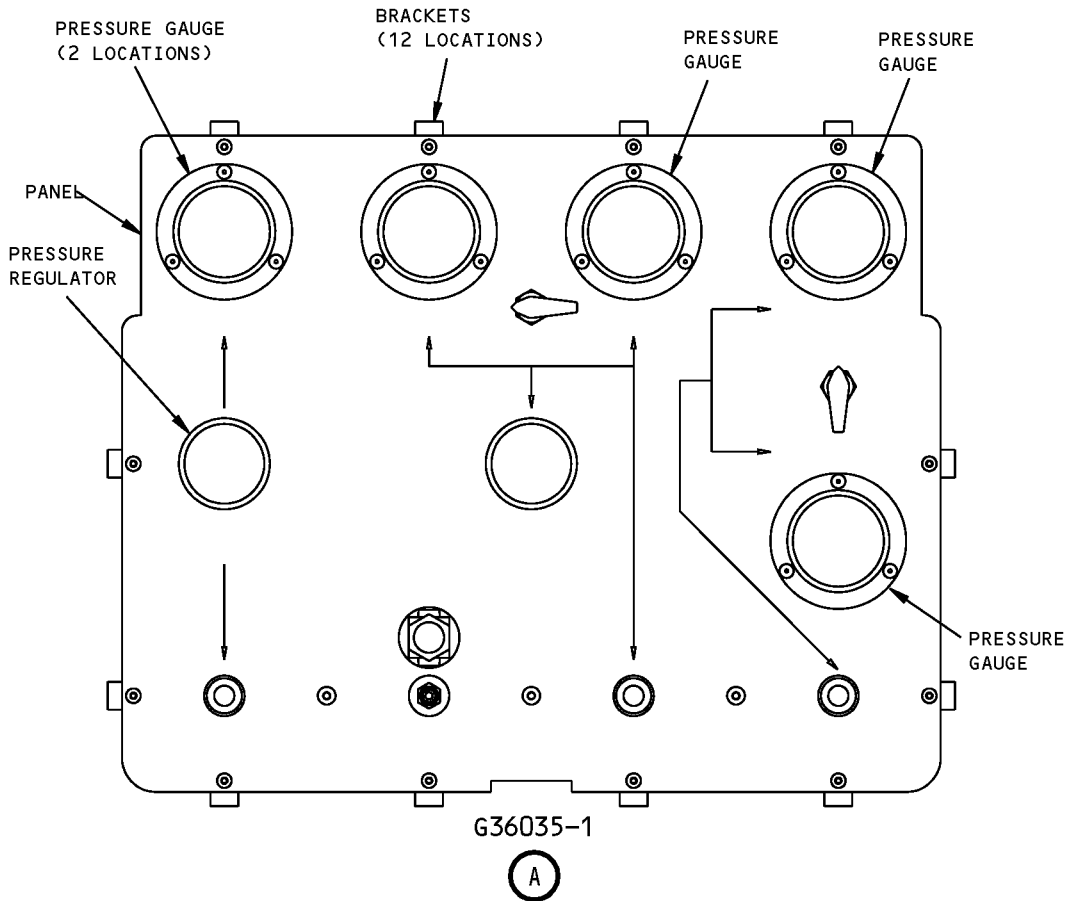

**Pneumatic System Health Check Test Equipment
Figure 1 (Sheet 1 of 2)**

ILLUSTRATED TOOL AND EQUIPMENT MANUAL

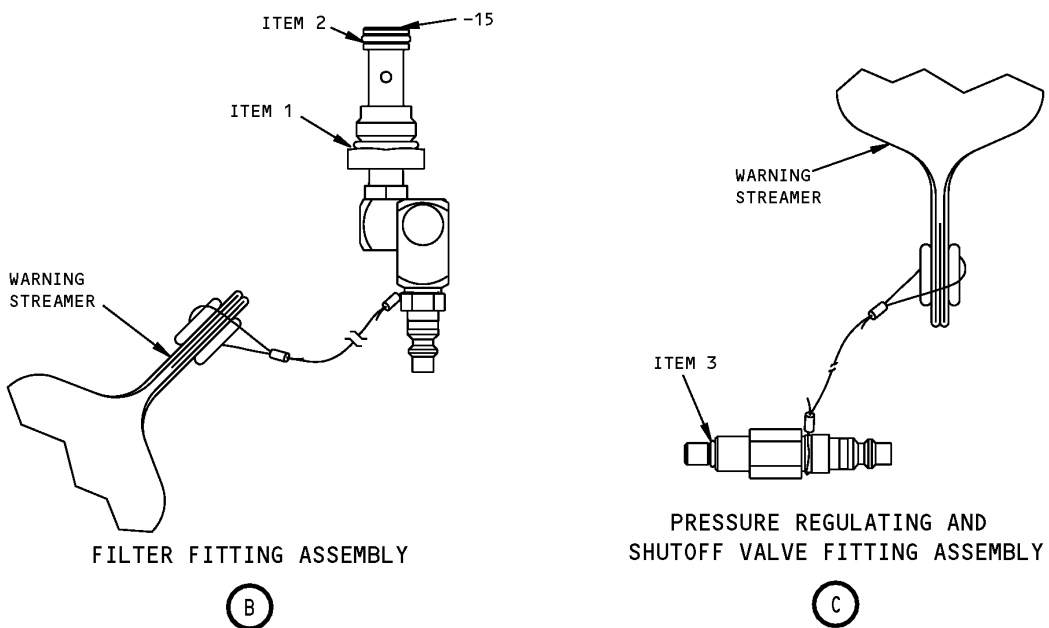

Pneumatic System Health Check Test Equipment
Figure 1 (Sheet 2 of 2)

REPAIRABLE/REPLACEABLE PART			
ITEM NO.	PART NO.	NOMENCLATURE	VENDOR CODE
1	AS568A-910	O-RING	V1LFP5
2	AS568A-112	O-RING	V1LFP5
3	AS568A-010	O-RING	V1LFP5

767
ILLUSTRATED TOOL AND EQUIPMENT MANUAL

PART NUMBER: A36021-1

NAME: ADAPTER CABLE - BITE MODULE, AIR SUPPLY SYSTEM

AIRPLANE MAINTENANCE: YES

COMPONENT MAINTENANCE: NO

USAGE & DESCRIPTION: The A36021-1 has limited usage on 767's with PW4000 and CF6-80C engines (except 767-400's). The usage includes 767 airplanes having S210T120-67 air supply, built in test equipment (BITE) module M129 and test points on the E1-2 shelf (typically, line number 346 and on. A36021 is also used on earlier 767 airplane incorporating Service Bulletin 767-36-0039. A36021-1 is used to connect the airplanes air supply system Bite module (right M129) via test points on the E1-2 shelf to perform a pneumatic system health check. Refer to AMM 36-00-30 and the current A36021 drawing for complete usage instructions. The A36021-1 consists of an A36021-2 cable assembly contained in a storage box.

WEIGHT: 3 lbs (1.4 kg)

DIMENSIONS: 3 x 10 x 10 inches (76 x 254 x 254 mm)

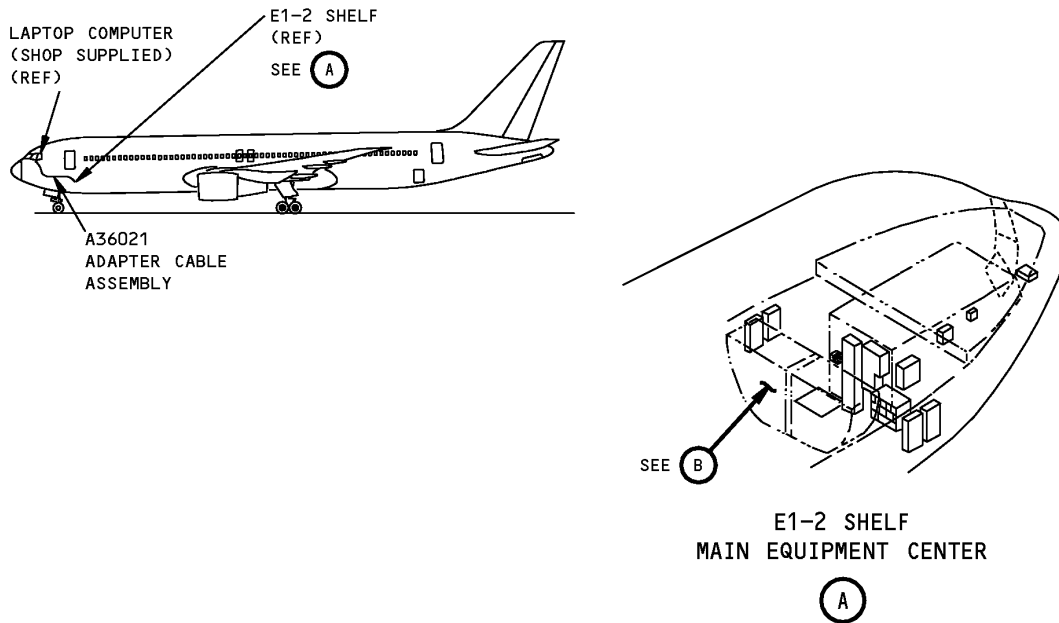

Air Supply System Bite Module Adapter Cable
Figure 1 (Sheet 1 of 4)

**767
ILLUSTRATED TOOL AND EQUIPMENT MANUAL**

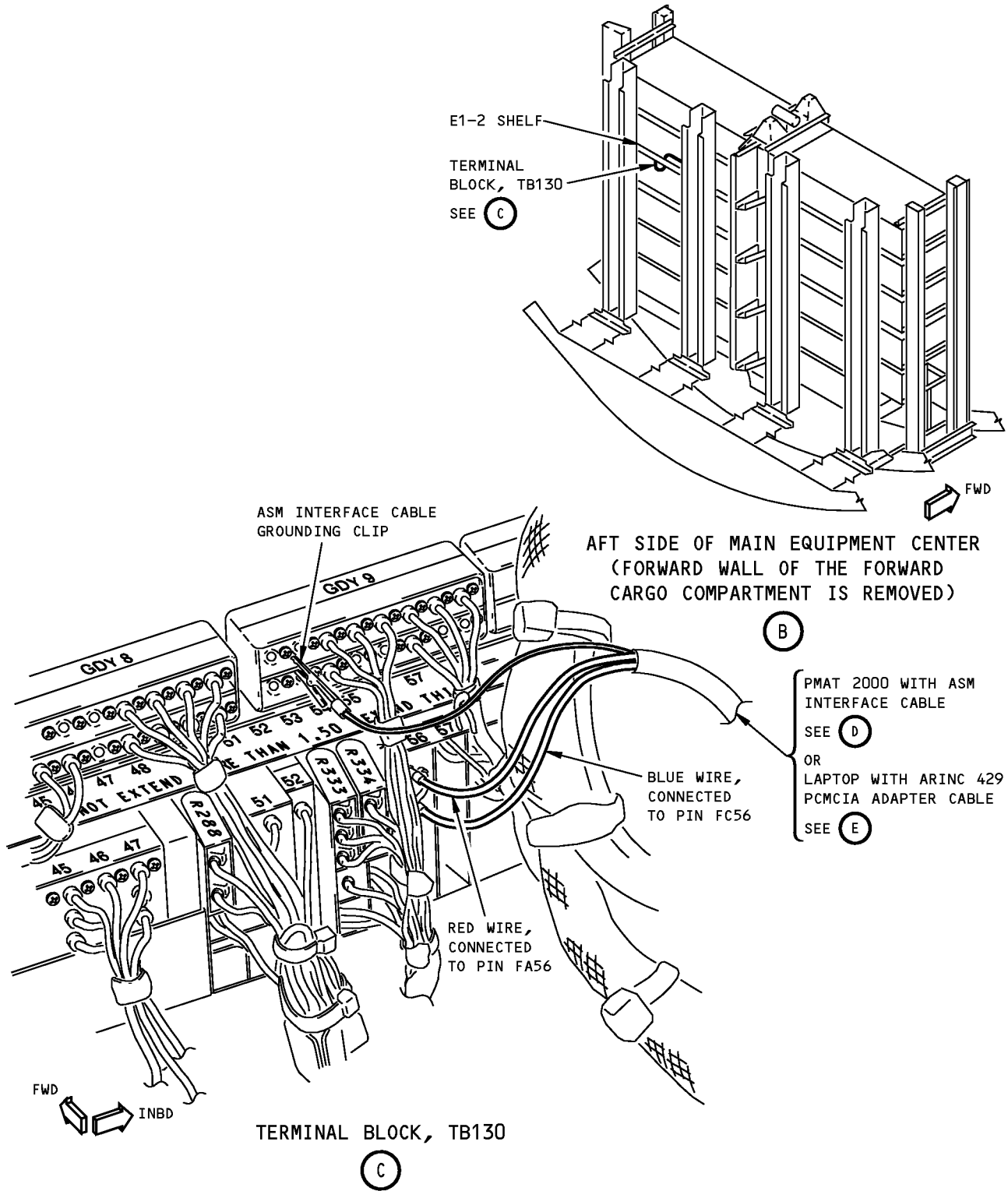

**Air Supply System Bite Module Adapter Cable
Figure 1 (Sheet 2 of 4)**

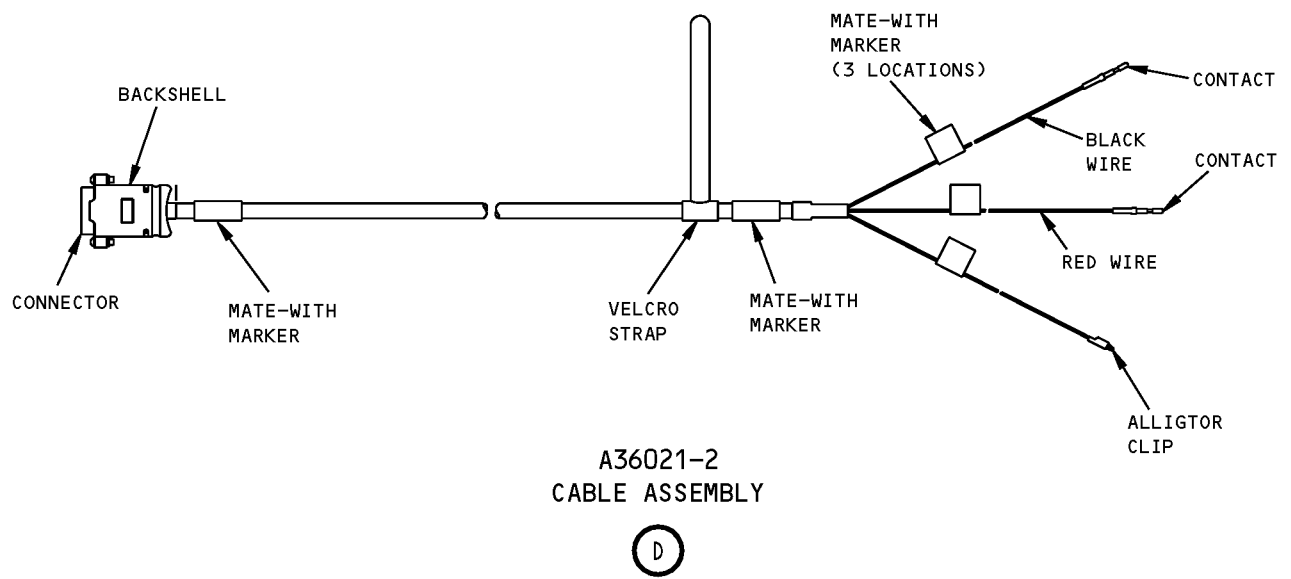

Air Supply System Bite Module Adapter Cable
Figure 1 (Sheet 3 of 4)

ILLUSTRATED TOOL AND EQUIPMENT MANUAL

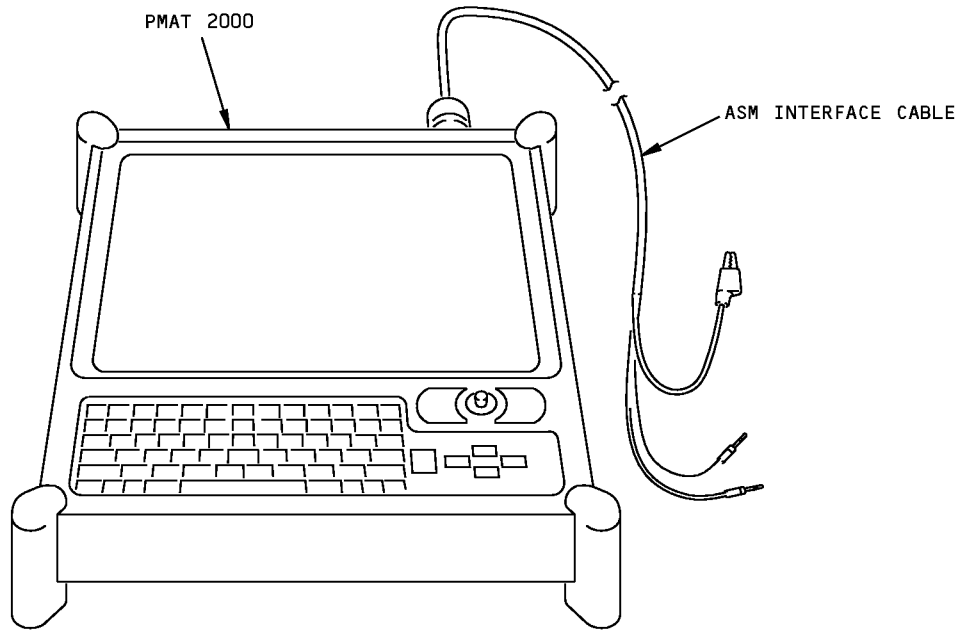

PMAT 2000 WITH ASM INTERFACE CABLE

(D)

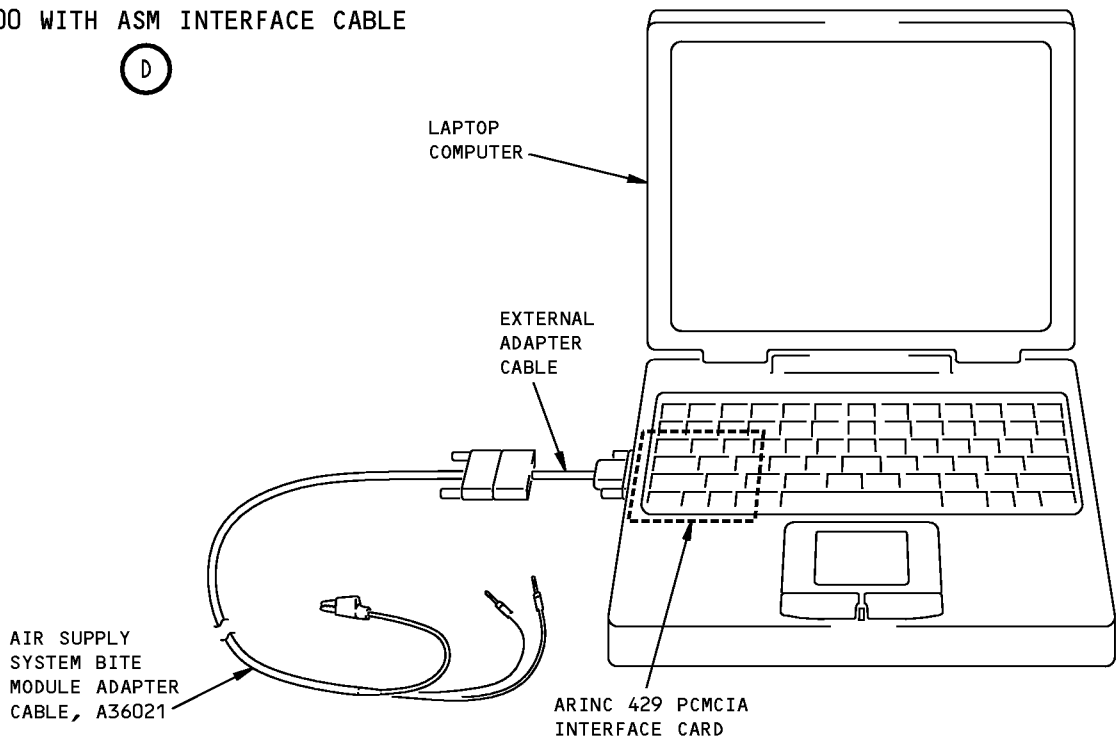

LAPTOP WITH ARINC 429 PCMCIA ADAPTER CABLE

(E)

Air Supply System Bite Module Adapter Cable
Figure 1 (Sheet 4 of 4)



767

ILLUSTRATED TOOL AND EQUIPMENT MANUAL

PART NUMBER: A71014-1, -24 WAS DELETED



767

ILLUSTRATED TOOL AND EQUIPMENT MANUAL

PART NUMBER: A36001-1, -24, -44, -45

NAME: REMOVAL/INSTALLATION EQUIPMENT - ENGINE PRECOOLER

AIRPLANE MAINTENANCE: YES

COMPONENT MAINTENANCE: NO

USAGE & DESCRIPTION: The A36001-1 or -45 removal installation equipment is used on 767 airplanes equipped with JT9D-7R4D or PW4000 engines. The A36001-24 or -44 removal installation equipment is used on 767 airplanes equipped with CF6-80A or CF6-80C2 engines. The A36001 equipment is an assortment of hand-operated lift devices that are used to remove and install the engine precooler. A36001 secures into support provisions in the precoolers and the various handles are used to lift the part into or out of position. Refer to AMM 36-11-15 for complete usage instructions. The A36001-44 and -45 removal/installation equipment consists of:

A36001-44		
QUANTITY	NOMENCLATURE	PART NUMBER
1	SMALL HANDLE ASSEMBLY	A36001-2
1	LARGE HANDLE ASSEMBLY	A36001-3
1	SMALL HANDLE ASSEMBLY (CF6-80A USE ONLY)	A36001-26
1	CARPET	A36001-42
2	HANDLE ASSEMBLY	A36001-48
1	STORAGE BOX	

A36001-45		
QUANTITY	NOMENCLATURE	PART NUMBER
2	SMALL HANDLE ASSEMBLY	A36001-2
1	LARGE HANDLE ASSEMBLY	A36001-3
2	WEDGES	A36001-43
2	HANDLE ASSEMBLY	A36001-48
1	STORAGE BOX	

WEIGHT: 15 lbs (7 kg)

DIMENSIONS: 8 x 14 x 28 inches (203 x 356 x 711 mm)

NOTE: A36001-45,-44 replace A36001-1,-24, respectively, for future procurement.

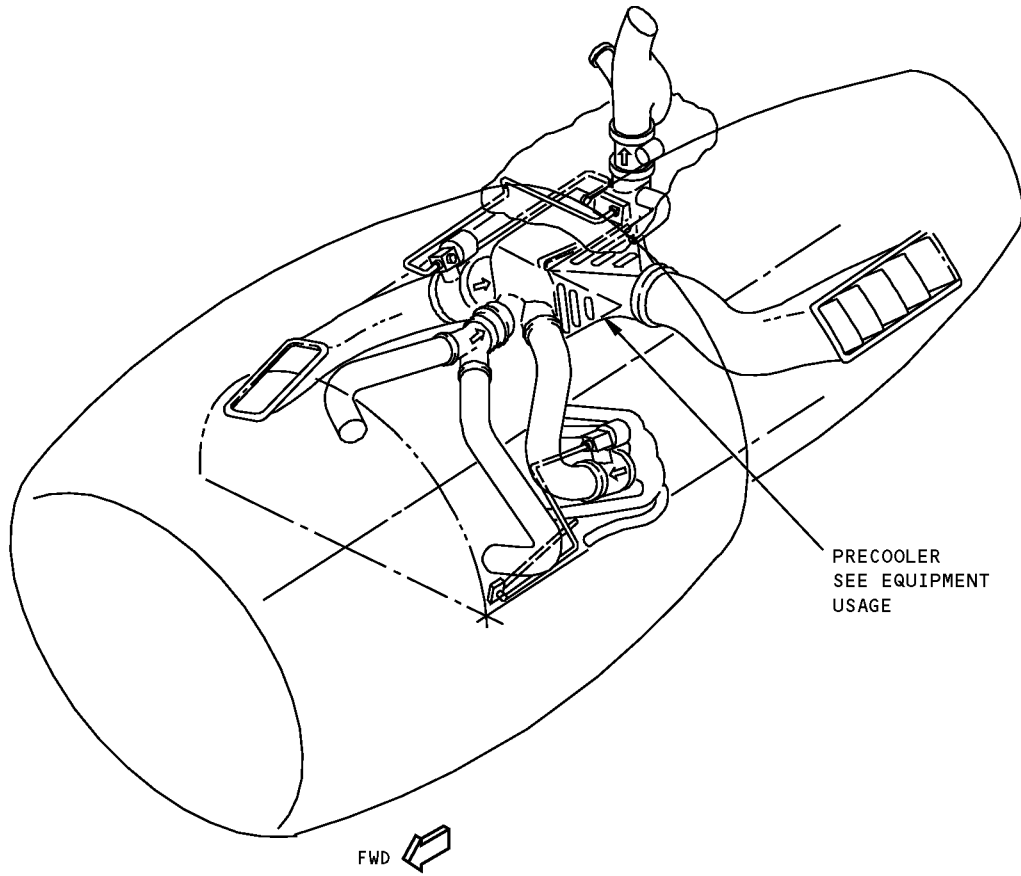

Engine Precooler Removal/Installation Equipment
Figure 1 (Sheet 1 of 3)

ILLUSTRATED TOOL AND EQUIPMENT MANUAL

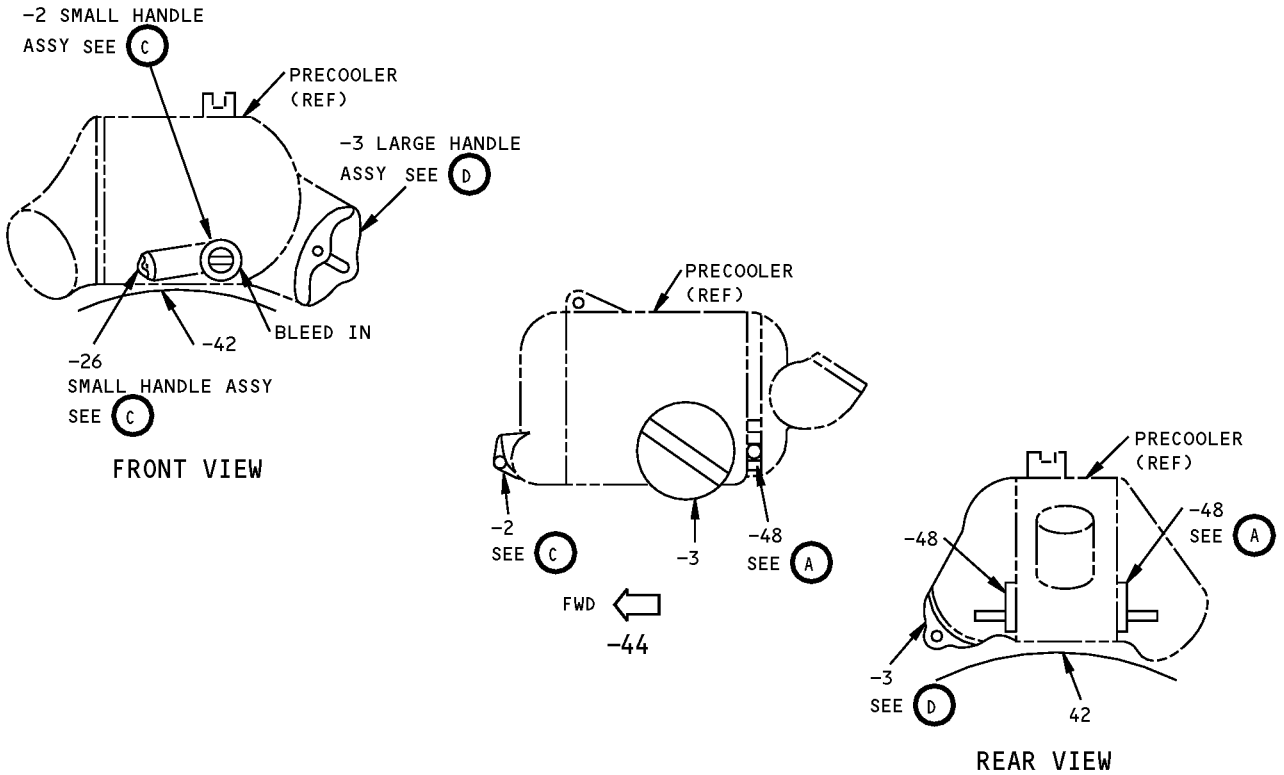

CF6-80A AND CF6-80C2 EQUIPMENT USAGE

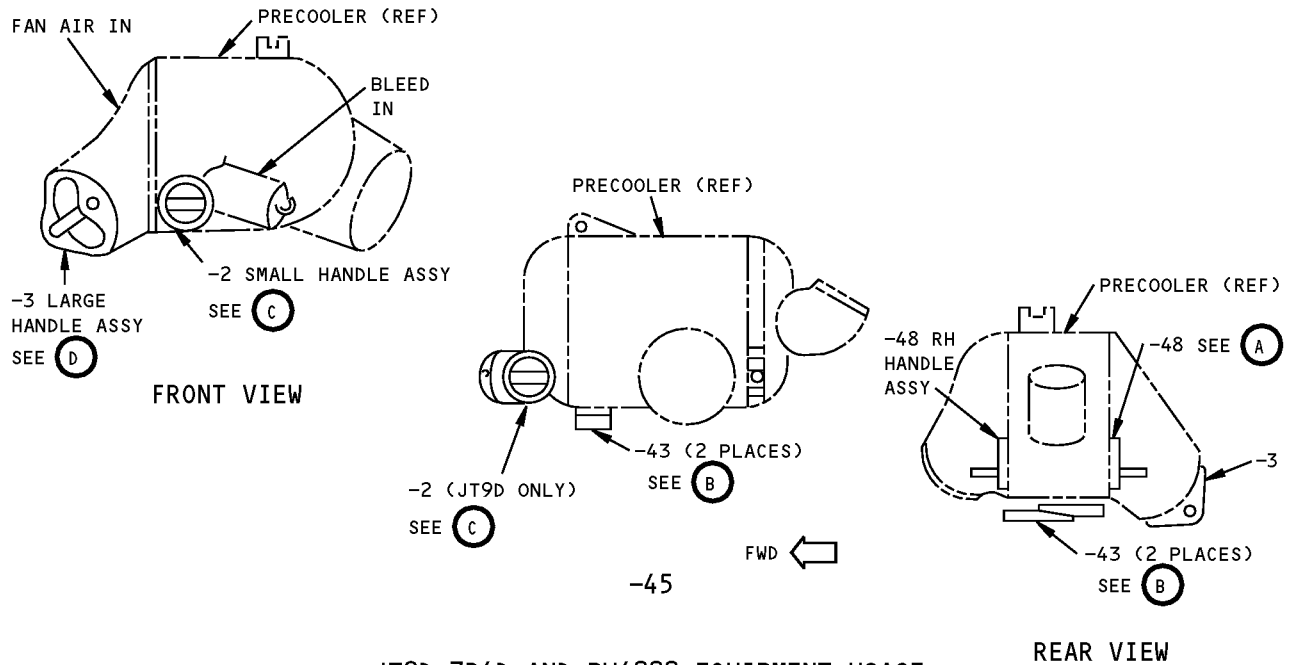

JT9D-7R4D AND PW4000 EQUIPMENT USAGE

**Engine Pre-cooler Removal/Installation Equipment
Figure 1 (Sheet 2 of 3)**

ILLUSTRATED TOOL AND EQUIPMENT MANUAL

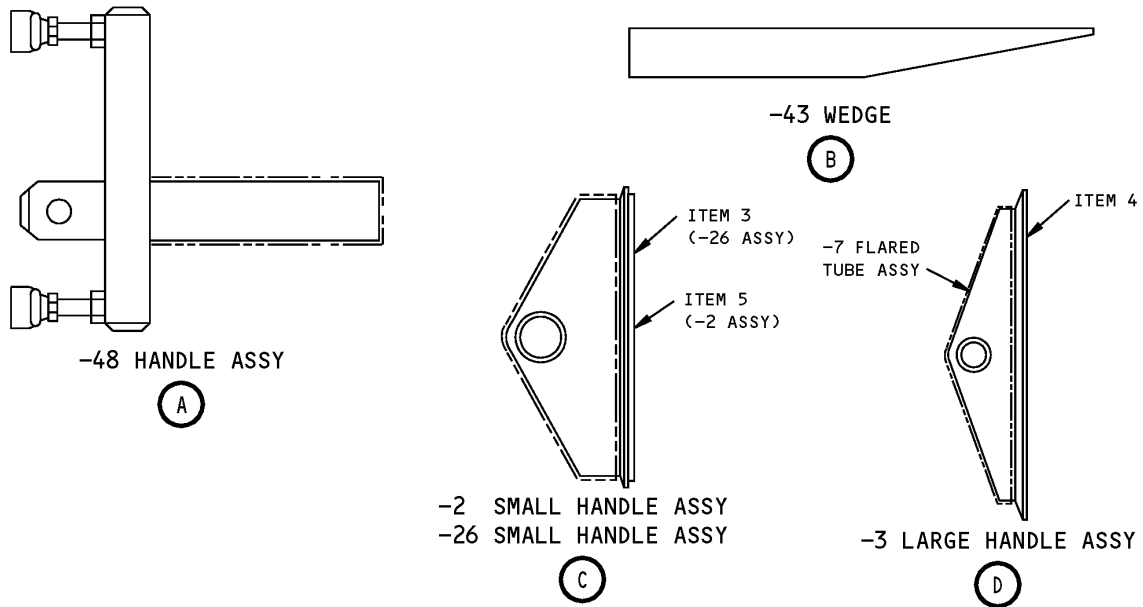

Engine Pre-cooler Removal/Installation Equipment
Figure 1 (Sheet 3 of 3)

REPAIRABLE/REPLACEABLE PARTS			
ITEM NO.	PART NO.	NOMENCLATURE	VENDOR CODE
3	A36001-29	PAD	
4	A36001-15	PAD	
5	A36001-12	PAD	

ILLUSTRATED TOOL AND EQUIPMENT MANUAL

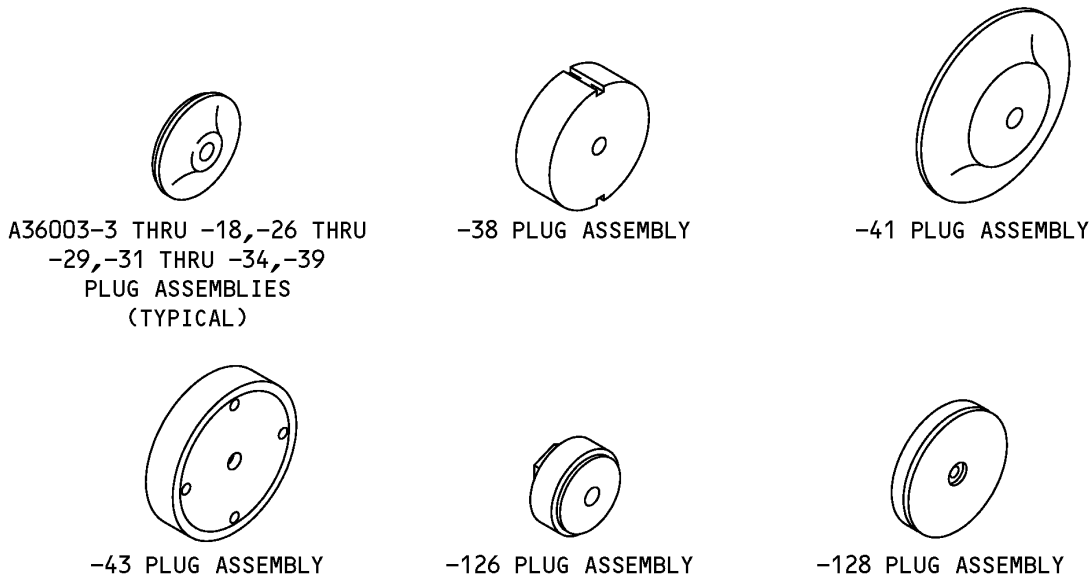
PART NUMBER: A36003-173**NAME:** PLUG SET - PNEUMATIC DUCTS HYDROSTATIC PRESSURE TEST**AIRPLANE MAINTENANCE:** NO**COMPONENT MAINTENANCE:** YES**USAGE & DESCRIPTION:** The A36003-173 plug set is used during component maintenance on all 767 airplanes. A36003 is used in the performance of hydrostatic proof pressure tests of 767 pneumatic duct systems. Refer to CMM 36-10-06 for complete use instructions. The plug set consists of various plug assemblies comprised of different diameter plugs, gaskets and clamps to facilitate testing assorted diameter ducts.**WEIGHT:** 14 (6 kg)**DIMENSIONS:** 6 x 18 x 18 inches (152 x 457 x 457 mm)**NOTE:** A36003-175 supersedes A36003-135.

**Pneumatic Ducts Hydrostatic Pressure Test Plug Set
Figure 1 (Sheet 1 of 2)**

ILLUSTRATED TOOL AND EQUIPMENT MANUAL

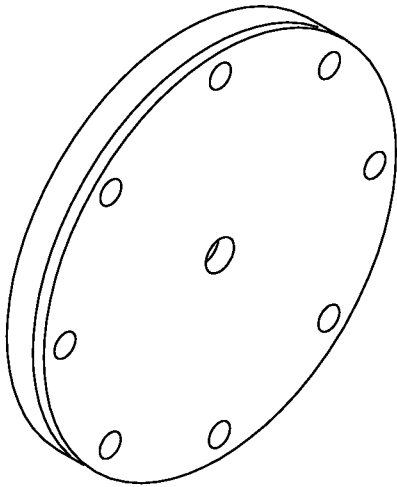

**-129,-133 PLUG ASSEMBLIES
(TYPICAL)**



**-130,-131,-132
PLUG ASSEMBLIES
(TYPICAL)**

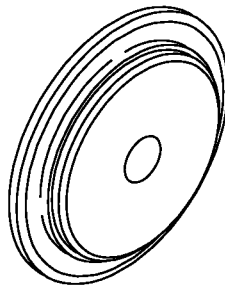

-174 PLUG

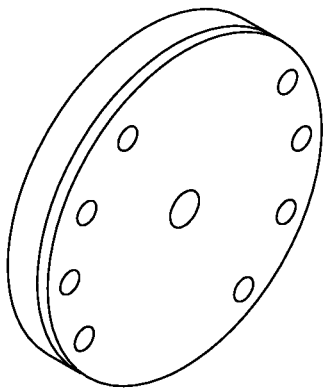

-134 PLUG ASSEMBLY

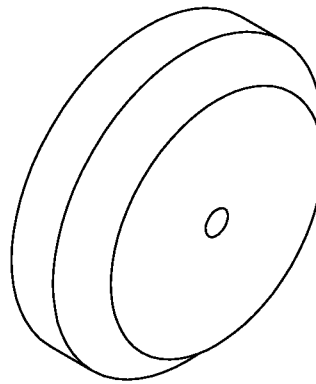

-175 CAP

**Pneumatic Ducts Hydrostatic Pressure Test Plug Set
Figure 1 (Sheet 2 of 2)**



767

ILLUSTRATED TOOL AND EQUIPMENT MANUAL

PART NUMBER: A36004-15, -20

NAME: INSTALLATION EQUIPMENT - CF6-80C2B BALL JOINT

AIRPLANE MAINTENANCE: YES

COMPONENT MAINTENANCE: YES

USAGE & DESCRIPTION: The A36004-15 installation equipment is used on all 767 airplanes during line and component maintenance. The A36004-20 installation tool is used on all 767 airplanes during component maintenance. A36004 is used to remove the engine air supply ducts. The A36004-15 installation equipment is used during both line and component maintenance. The A36004-3 adjustment wrench assembly (alternately named the alignment bar assembly) (part of A36004-15) is used to align the flanged retainer of the 322T1233 ball joint relative to the duct. The A36004-16 spanner wrench assembly (also part of A36004-15) is used to loosen the ball joint nut if the flanged retainer cannot be moved. If the duct has been removed from the airplane for service, the A36004-22 restrainer wrench assembly (part of A36004-20) must be used together with the A36004-16 spanner wrench assembly. A36004-15 and -20 consist of:

A36004-15		
QUANTITY	NOMENCLATURE	PART NUMBER
1	ADJUSTMENT WRENCH ASSEMBLY	A36004-3
1	SPANNER WRENCH ASSEMBLY	A36004-16
1	STORAGE BOX	

A36004-20		
QUANTITY	NOMENCLATURE	PART NUMBER
1	RESTRAINER WRENCH ASSEMBLY	A36004-22
1	STORAGE BOX	

WEIGHT: A36004-15 - 7 lbs (3.2 kg)
A36004-20 - 3 lbs (1.4 kg)

DIMENSIONS: A36004-15 - 6 x 6 x 20 inches (152 x 152 x 508 mm)
1 x 5 x 6 inches (25 x 127 x 152 mm)

NOTE: A36004-15 supersedes A36004-1.

ILLUSTRATED TOOL AND EQUIPMENT MANUAL

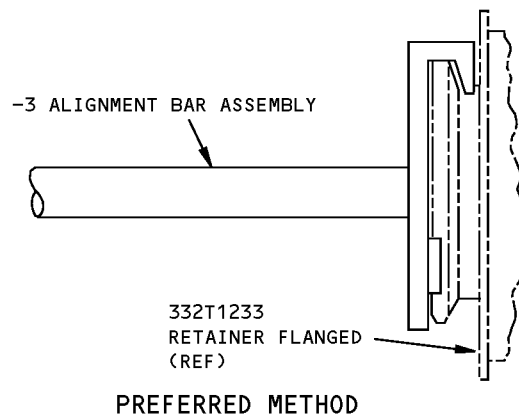
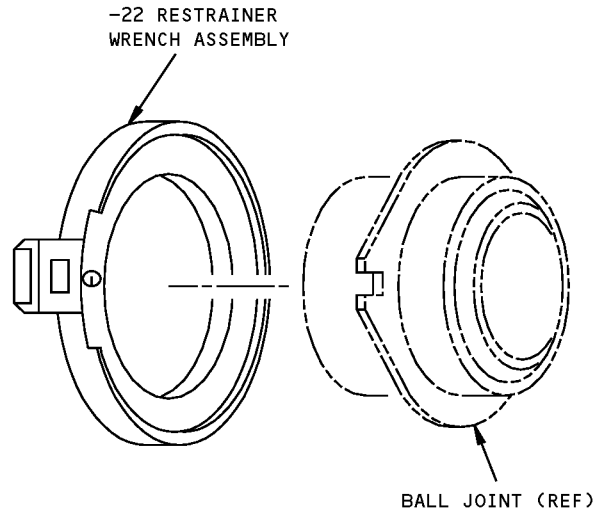
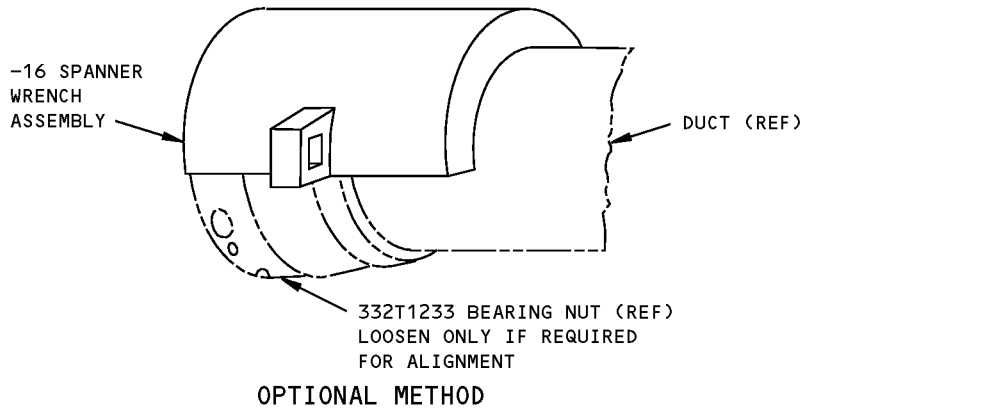

**CF6-80C2B Ball Joint Installation Equipment
Figure 1**



767

ILLUSTRATED TOOL AND EQUIPMENT MANUAL

PART NUMBER: B36005-2, -4

NAME: PLUG EQUIPMENT - DUCT TEST

AIRPLANE MAINTENANCE: NO

COMPONENT MAINTENANCE: YES

USAGE & DESCRIPTION: The B36005-2 or -4 plug equipment is used during component maintenance on all 767 airplanes. B36005 is used for hydrostatic pressure testing of ducts. B36005-2 and -4 consists of:

B36005-2		
QUANTITY	NOMENCLATURE	PART NUMBER
1	PLUG ASSEMBLY	B36005-202
1	CLAMP HALF	B36005-303
1	CLAMP HALF	B36005-304
2	BOLT	AN9-26
2	SCREW	MS16995-54
1	STORAGE BOX	

B36005-4		
QUANTITY	NOMENCLATURE	PART NUMBER
1	PLUG ASSEMBLY	B36005-202
1	CLAMP HALF	B36005-303
1	CLAMP HALF	B36005-304
2	BOLT	NAS6609-8
2	SCREW	NAS1352-4-20
1	STORAGE BOX	

WEIGHT: 7 lbs (3.2 kg)

DIMENSIONS: 1 x 6 x 8 inches (25 X 203 X 203 mm)

NOTE: B36005-4 replaces the B36005-2 for future procurement

ILLUSTRATED TOOL AND EQUIPMENT MANUAL

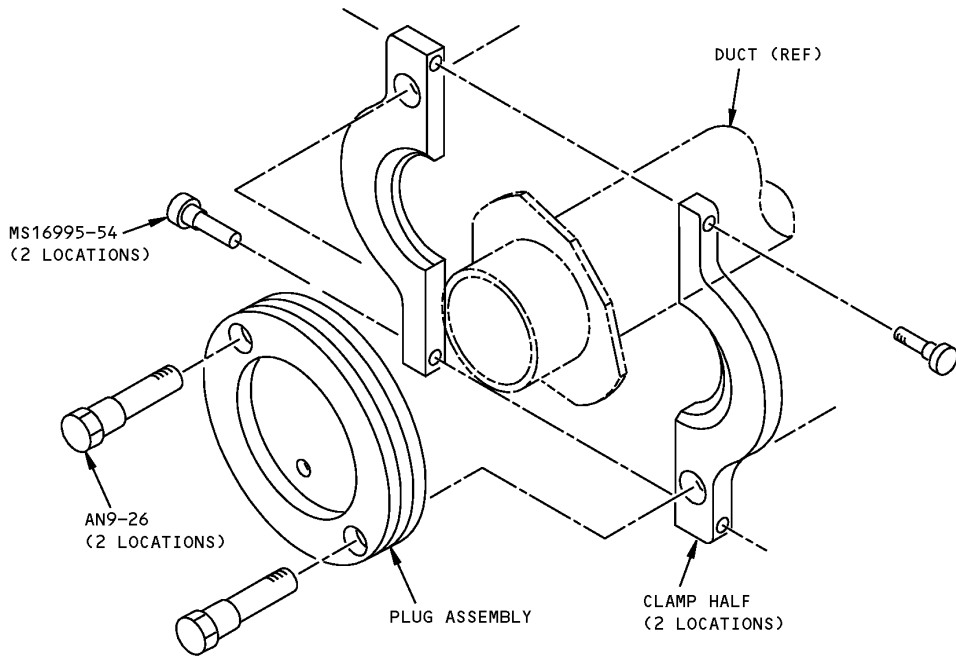

**Duct Test Plug Equipment
Figure 1**



767

ILLUSTRATED TOOL AND EQUIPMENT MANUAL

PART NUMBER: A36005-1, -15

NAME: HOLD OPEN EQUIPMENT - PRESSURE REGULATING AND SHUT-OFF VALVE (PRSOV)

AIRPLANE MAINTENANCE: YES

COMPONENT MAINTENANCE: NO

USAGE & DESCRIPTION: A36005-1 or -15 hold open equipment is used on 767 airplanes equipped with PW4000, JT9D and CF6-80A engines. A36005-1 or -15 is also used on 767 airplanes prior to line number 334 equipped with CF6-80C2 engines. A36005 is used to hold the valve and cam of the pressure regulating and shut off valve in the open position during testing of pneumatically operated thrust reversers or other pneumatic components. Refer to AMM 36-11-09 for complete usage instructions. A36005-1 consists of a A36005-2 valve lock assembly contained in a storage box. The A36005-15 consists of a A36005-16 valve lock assembly contained in a storage box.

WEIGHT: 1 lb (0.5 kg)

DIMENSIONS: 3 x 4 x 5 inches (76 x 102 x 127 mm)

NOTE: A36005-15 replaces A36005-1 for future procurement.
A36005 supersedes A71043.

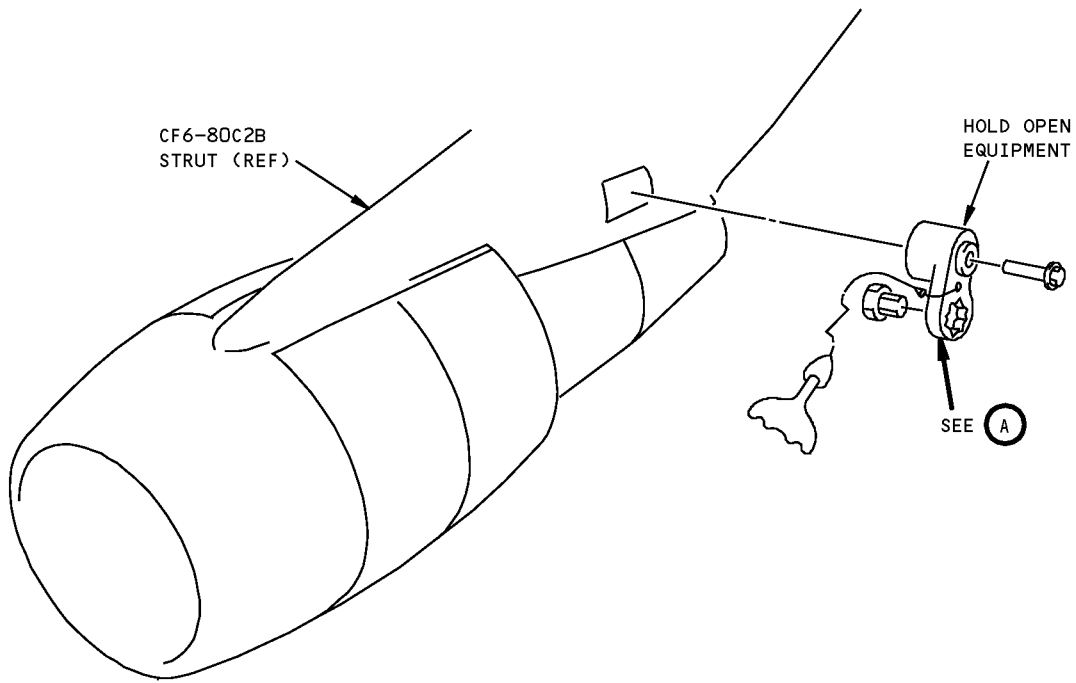

**Pressure Regulating And Shut-Off Valve Hold Open Equipment
Figure 1 (Sheet 1 of 2)**

ILLUSTRATED TOOL AND EQUIPMENT MANUAL

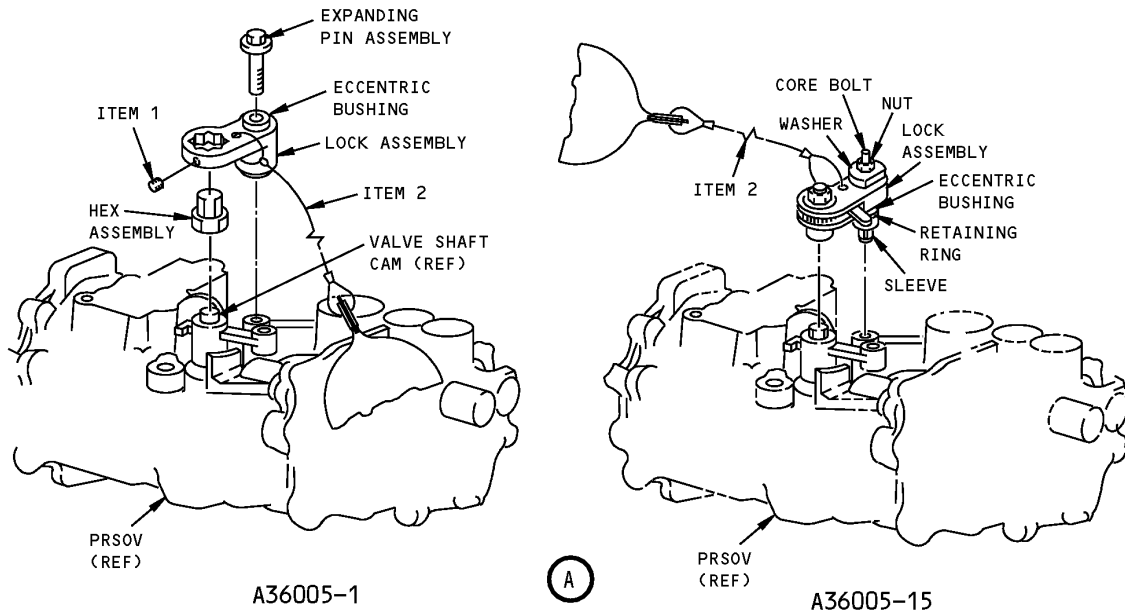

**Pressure Regulating And Shut-Off Valve Hold Open Equipment
Figure 1 (Sheet 2 of 2)**

REPAIRABLE/REPLACEABLE PARTS			
ITEM NO.	PART NO.	NOMENCLATURE	VENDOR CODE
1	MS1965-29	SET SCREW	
2	CL-23-KA-10.0-LR	CABLE ASSEMBLY	V99862



767

ILLUSTRATED TOOL AND EQUIPMENT MANUAL

PART NUMBER: A36010-1

NAME: PRESSURE TEST EQUIPMENT - DUCT ASSEMBLY

AIRPLANE MAINTENANCE: NO

COMPONENT MAINTENANCE: YES

USAGE & DESCRIPTION: The A36010-1 pressure test equipment is used on 767-200,-300 airplanes only. This equipment is used to seal flange 332T1244 during pressure testing of 332T1236 duct assembly. Refer to CMM 36-10-06 complete usage instructions. A36010-1 consists of:

A36010-1		
QUANTITY	NOMENCLATURE	PART NUMBER
1	PLUG ASSEMBLY	A36010-2
1	CLAMP HALF	A36010-4
1	THREADED CLAMP HALF	A36010-5
6	WASHER	AN960-816
6	SCREW	MS90728-113
1	STORAGE BOX	

WEIGHT: 16 lbs (7 kg)

DIMENSIONS: 4 x 11 x 13 inches (102 x 279 x 330 mm)

ILLUSTRATED TOOL AND EQUIPMENT MANUAL

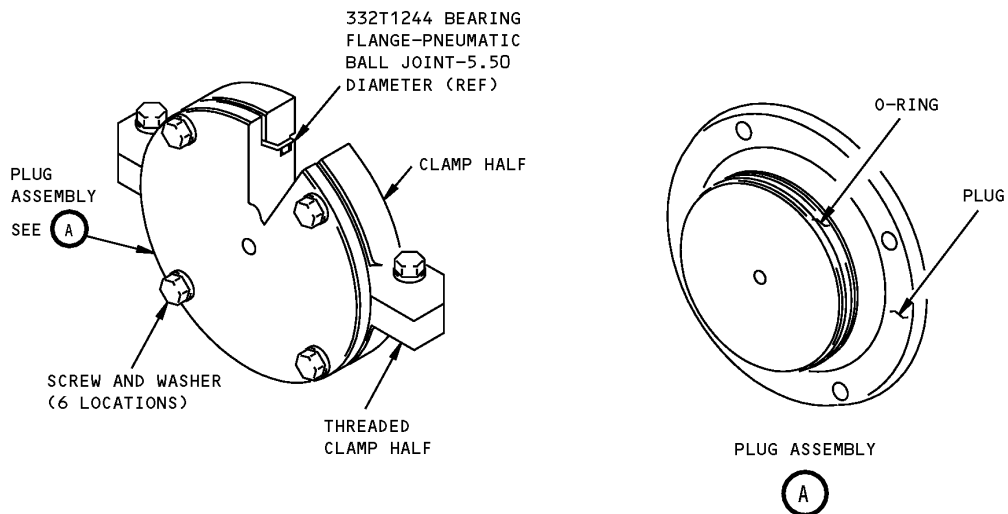

Duct Assembly Pressure Test Equipment
Figure 1

REPAIRABLE/REPLACEABLE PARTS			
ITEM NO.	PART NO.	NOMENCLATURE	VENDOR CODE
1	AN960-816	WASHER	
2	MS90728-113	SCREW	
3	2-428 N674-70	O-RING	



767

ILLUSTRATED TOOL AND EQUIPMENT MANUAL

PART NUMBER: A36011-1

NAME: PRESSURE TEST EQUIPMENT - DUCT ASSEMBLY

AIRPLANE MAINTENANCE: NO

COMPONENT MAINTENANCE: YES

USAGE & DESCRIPTION: The A36011-1 pressure test equipment is used during component maintenance on all 767 airplanes. A36011 is used to plug the flange on 212T3114 duct assembly during the hydrostatic proof pressure test. Refer to CMM 36-10-06 for complete usage instructions. A36011-1 consists of:

A36011-1		
QUANTITY	NOMENCLATURE	PART NUMBER
2	CLAMP	A36011-3
1	PLUG	A36011-4
4	WASHER	AN960-816
2	SCREW	MS16997-147
2	NUT	MS35691-33
1	O-RING	2-251-E540-80
1	STORAGE BOX	

WEIGHT: 13 lbs (6 kg)

DIMENSIONS: 2 x 7 x 10 inches (51 x 178 x 254 mm)

767
ILLUSTRATED TOOL AND EQUIPMENT MANUAL

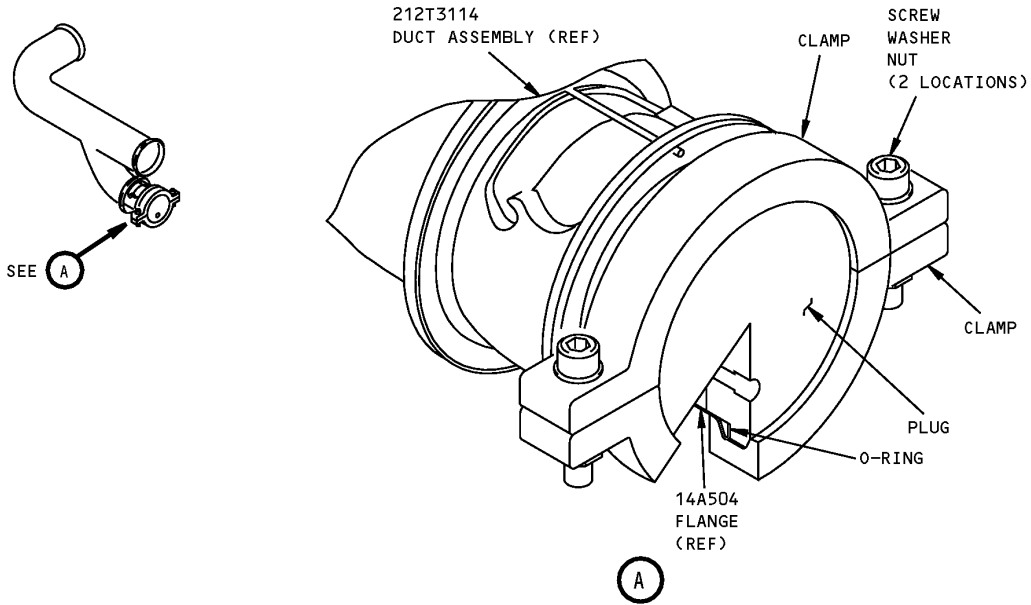

Duct Assembly Pressure Test Equipment
Figure 1

REPAIRABLE/REPLACEABLE PARTS			
ITEM NO.	PART NO.	NOMENCLATURE	VENDOR CODE
1	AN960-816	WASHER	
2	MS16997-147	SCREW	
3	MS35691-33	NUT	
4	2-251-E540-80	O-RING	V02697



767

ILLUSTRATED TOOL AND EQUIPMENT MANUAL

PART NUMBER: A36012-1

NAME: PRESSURE TEST EQUIPMENT - DUCT ASSEMBLY

AIRPLANE MAINTENANCE: NO

COMPONENT MAINTENANCE: YES

USAGE & DESCRIPTION: The A36012-1 pressure test equipment is used on 767-300 airplanes with RB211-524H engines. A36012 is used to plug the 312T5324-2 flange on the 312T5321 duct assembly during the hydrostatic proof pressure test. Refer to CMM 36-10-06 and the current A36012 drawing for complete usage instructions. A36012-1 consists of:

A36012-1		
QUANTITY	NOMENCLATURE	PART NUMBER
1	PLUG ASSEMBLY	A36012-2
2	CLAMP HALF	A36012-4
4	WASHER	AN960-816
2	NUT	MS35691-33
2	SCREW	MS90728-119
1	STORAGE BOX	

WEIGHT: 5 lbs (2.3 kg)

DIMENSIONS: 5 x 10 x 13 inches (127 x 254 x 330 mm)

767
ILLUSTRATED TOOL AND EQUIPMENT MANUAL

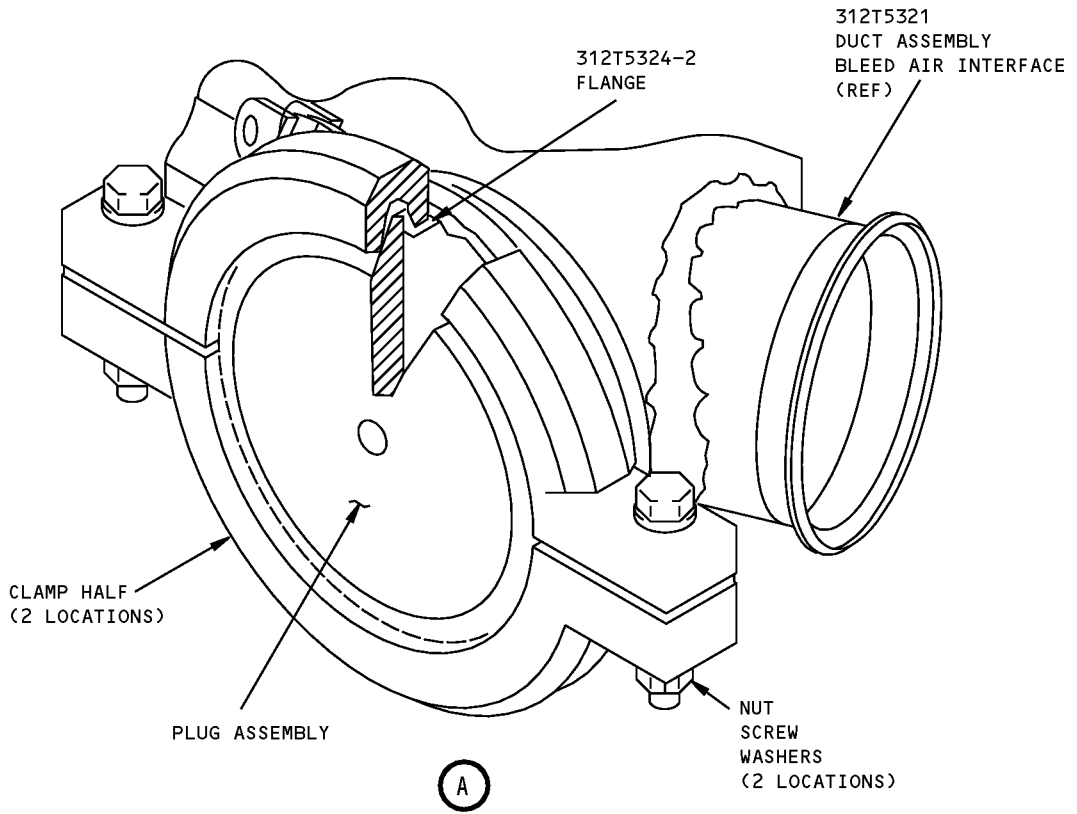
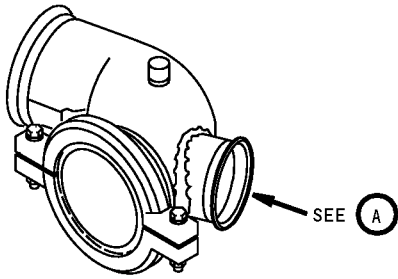

Duct Assembly Pressure Test Equipment
Figure 1



767

ILLUSTRATED TOOL AND EQUIPMENT MANUAL

PART NUMBER: A36013-1

NAME: PRESSURE TEST EQUIPMENT - DUCT ASSEMBLY

AIRPLANE MAINTENANCE: NO

COMPONENT MAINTENANCE: YES

USAGE & DESCRIPTION: The A36013-1 pressure test equipment is used during component maintenance on 767 airplanes with Pratt and Whitney engines. A36013 is used to seal 332T4339 flange during pressure test of 332T4326 duct assembly. Refer to CMM 36-10-06 for complete usage instructions. A36013-1 consists of:

A36013-1		
QUANTITY	NOMENCLATURE	PART NUMBER
1	PLUG ASSEMBLY	A36013-2
8	BOLT	AN4-7
16	WASHER	AN960-416L
8	NUT	MS35681-5
1	STORAGE BOX	

WEIGHT: 5 lbs (2.3 kg)

DIMENSIONS: 1 x 6 x 6 inches (25 x 152 x 152 mm)

767
ILLUSTRATED TOOL AND EQUIPMENT MANUAL

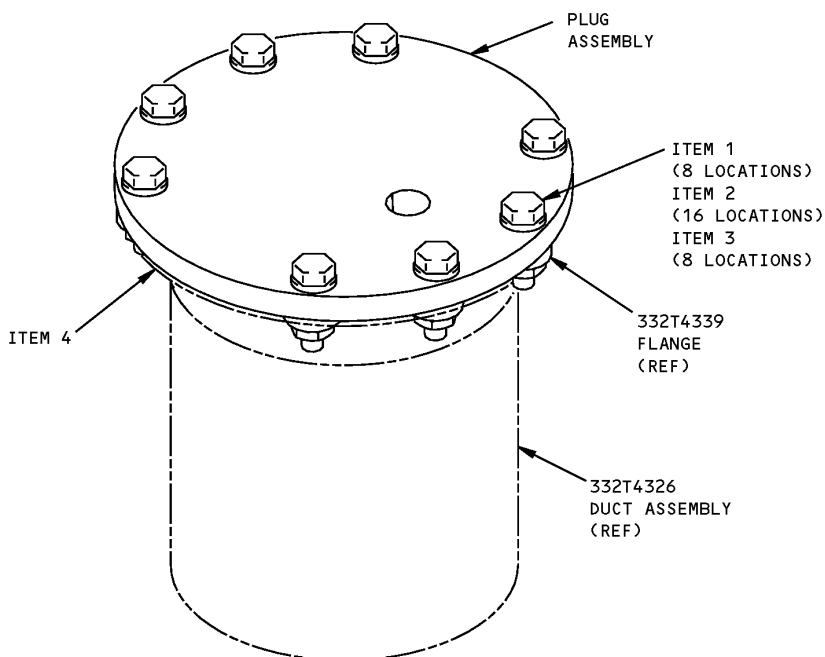

Duct Assembly Pressure Test Equipment
Figure 1

REPAIRABLE/REPLACEABLE PARTS			
ITEM NO.	PART NO.	NOMENCLATURE	VENDOR CODE
1	AN4-7	BOLT	
2	AN960-416L	WASHER	
3	MS35681-5	NUT	
4	2-340 N674-70	O-RING	V02697



767

ILLUSTRATED TOOL AND EQUIPMENT MANUAL

PART NUMBER: A36008-1

NAME: PRESSURE TEST EQUIPMENT - DUCT ASSEMBLY

AIRPLANE MAINTENANCE: NO

COMPONENT MAINTENANCE: YES

USAGE & DESCRIPTION: The A36008-1 pressure test equipment is used during component maintenance on 767 airplanes equipped with Pratt Whitney JT9D engines. A36008 is used to seal flange 332T3075 when testing duct assemblies 332T3235, 332T3238 and 332T3239. Refer to CMM 36-10-06 for complete usage instructions. A36008-1 consists of:

A36008-1		
QUANTITY	NOMENCLATURE	PART NUMBER
1	CLAMP ASSEMBLY	A36008-2
1	PLUG	A36008-3
1	O-RING	2-144
1	STORAGE BOX	

WEIGHT: 4 lbs (1.8 kg)

DIMENSIONS: 1 x 4 x 6 inches (25 x 102 x 152 mm)

ILLUSTRATED TOOL AND EQUIPMENT MANUAL

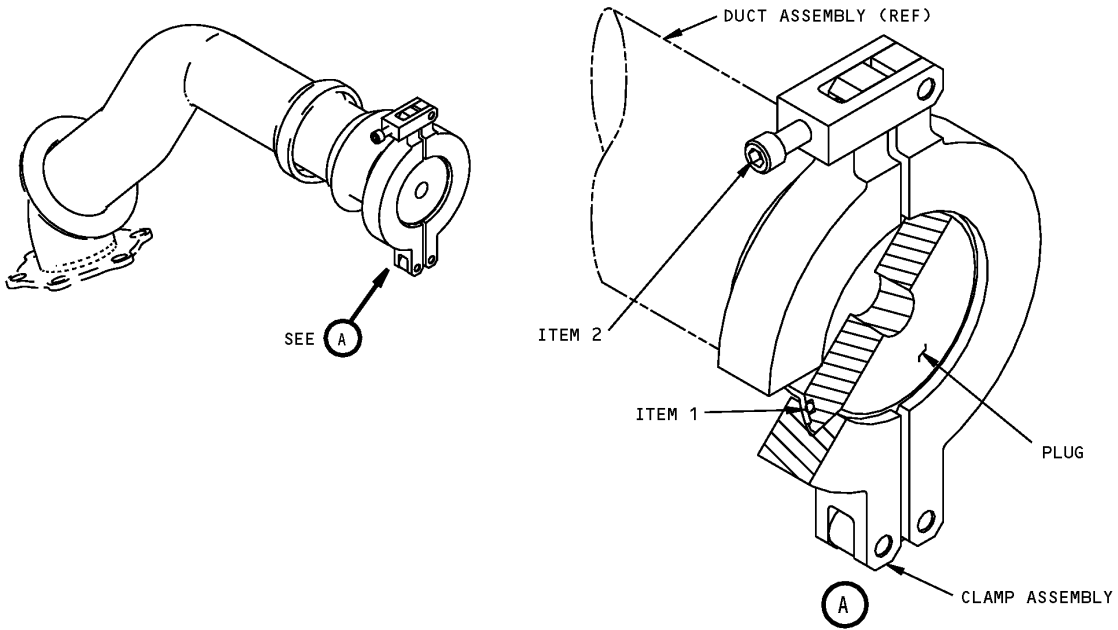

**Duct Assembly Pressure Test Equipment
Figure 1**

REPAIRABLE/REPLACEABLE PARTS			
ITEM NO.	PART NO.	NOMENCLATURE	VENDOR CODE
1	2-144-N674-70	O-RING	
2	MS16997-62	SOCKET HEAD CAP SCREW	

ILLUSTRATED TOOL AND EQUIPMENT MANUAL

PART NUMBER: A36016-1

NAME: PRESSURE TEST PLUG - DUCT ASSEMBLY

AIRPLANE MAINTENANCE: NO

COMPONENT MAINTENANCE: YES

USAGE & DESCRIPTION: The A36016-1 pressure test plug is used during component maintenance on 767-200 and -300 airplanes only. A36016 is used to seal boss assembly 213T2119-1 during hydrostatic pressure testing of duct assemblies 212N3091, 212N3092, 213N1007, 213N1008, 213N1100 and 213T2100. Refer to CMM 36-10-06 for complete usage instructions. A36016-1 consists of a A36016-2 plug assembly contained in a storage box.

WEIGHT: 5 lbs (2.3 kg)

DIMENSIONS: 2 x 3 x 4 inches (51 x 76 x 102 mm)

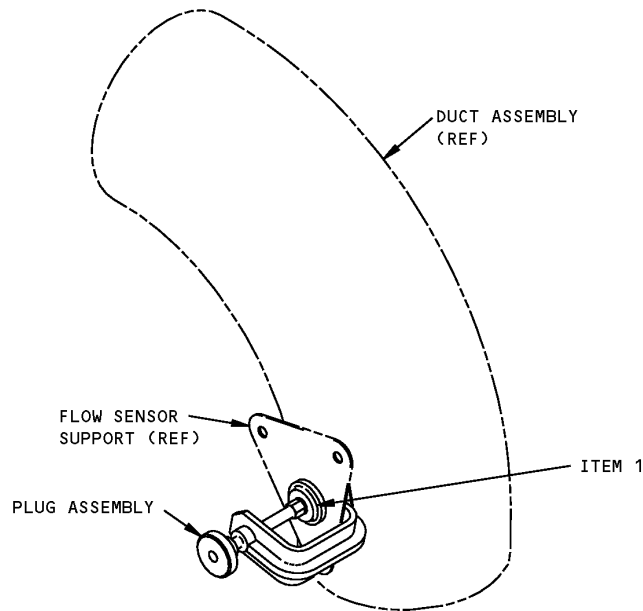

**Duct Assembly Pressure Test Plug
Figure 1**

REPAIRABLE/REPLACEABLE PARTS			
ITEM NO.	PART NO.	NOMENCLATURE	VENDOR CODE
1	A36016-7	O-RING	



767

ILLUSTRATED TOOL AND EQUIPMENT MANUAL

PART NUMBER: A36009-1

NAME: PRESSURE TEST EQUIPMENT - DUCT ASSEMBLY

AIRPLANE MAINTENANCE: NO

COMPONENT MAINTENANCE: YES

USAGE & DESCRIPTION: The A36009-1 pressure test equipment is used during component maintenance on all 767 airplanes. A36009 is used to plug the 212W3703-1 flange on the 212T3130 pneumatic ducts during hydrostatic pressure test. Refer to CMM 36-10-06 for complete usage instructions. A36009-1 consists of:

A36009-1		
QUANTITY	NOMENCLATURE	PART NUMBER
1	PLUG	A36009-3
12	NUT	A36009-4
12	BOLT	A36009-5
24	WASHER	A36009-6
1	O-RING	A36009-7
1	STORAGE BOX	

WEIGHT: 7 lbs (3.2 kg)

DIMENSIONS: 2 x 7 x 7 inches (51 x 178 x 178 mm)

767
ILLUSTRATED TOOL AND EQUIPMENT MANUAL

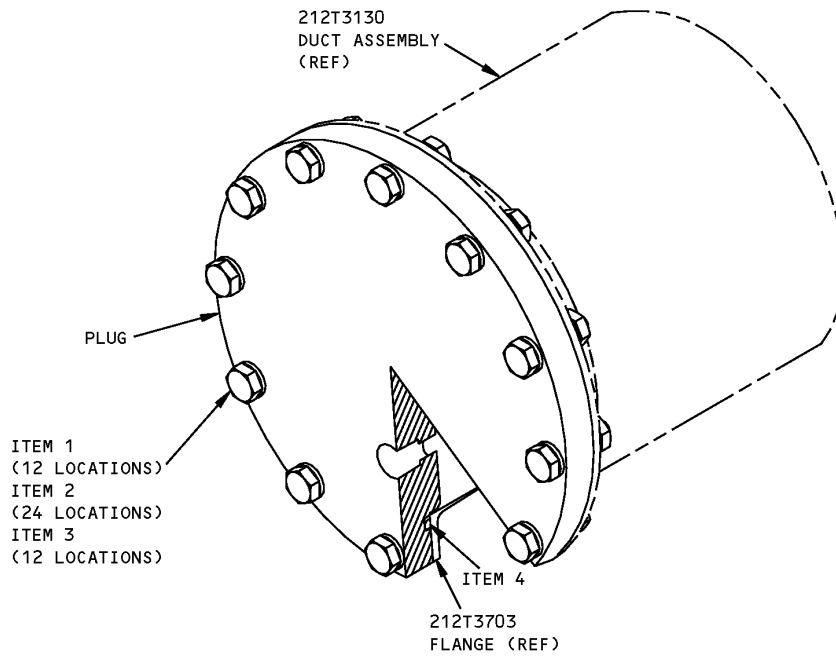

Duct Assembly Pressure Test Equipment
Figure 1

REPAIRABLE/REPLACEABLE PARTS			
ITEM NO.	PART NO.	NOMENCLATURE	VENDOR CODE
1	A36009-4	NUT	
2	A36009-6	WASHER	
3	A36009-5	BOLT	
4	A36009-7	O-RING	V02697



767

ILLUSTRATED TOOL AND EQUIPMENT MANUAL

PART NUMBER: J36010-1

NAME: PRESSURE TEST EQUIPMENT - DUCT ASSEMBLY

AIRPLANE MAINTENANCE: NO

COMPONENT MAINTENANCE: YES

USAGE & DESCRIPTION: The J36010-1 pressure test equipment is used during component maintenance on all 767 airplanes. J36010 is used to plug 212W1652-1 and 212T3703-2 flanges on the pneumatic duct assembly during hydrostatic pressure test. Refer to CMM 36-10-06 for complete usage instructions. J36010-1 consists of:

J36010-1		
QUANTITY	NOMENCLATURE	PART NUMBER
1	PLUG	J36010-2
12	NUT	J36010-4
12	BOLT	J36010-5
24	WASHER	J36010-6
1	O-RING	J36010-7
1	STORAGE BOX	

WEIGHT: 3 lbs (1.4 kg)

DIMENSIONS: 2 x 6 x 6 inches (51 x 152 x 152 mm)

ILLUSTRATED TOOL AND EQUIPMENT MANUAL

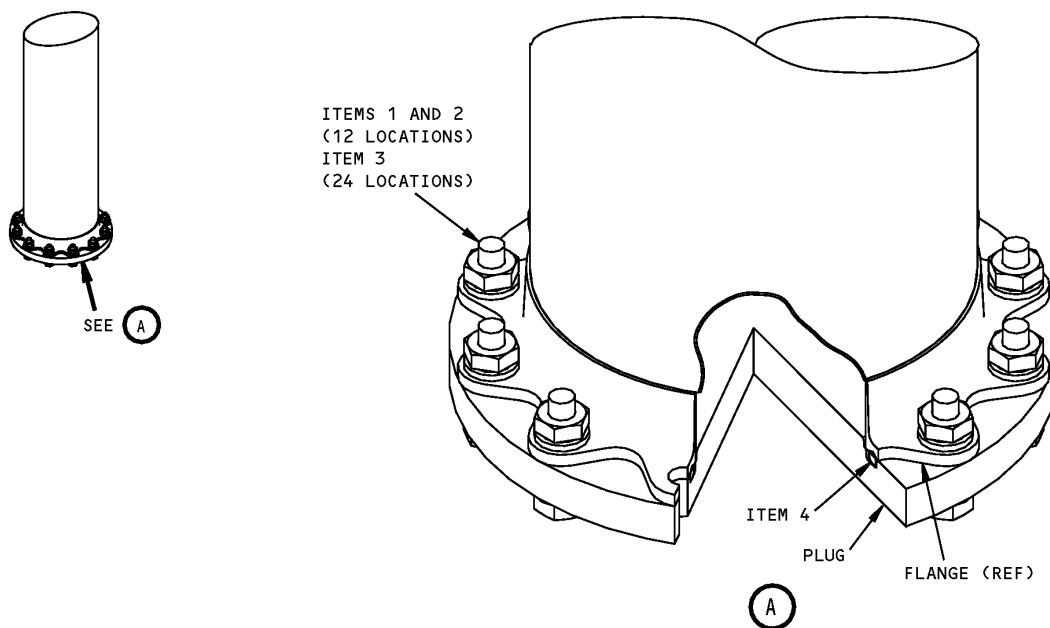

Duct Assembly Pressure Test Equipment
Figure 1

REPAIRABLE/REPLACEABLE PARTS			
ITEM NO.	PART NO.	NOMENCLATURE	VENDOR CODE
1	J36010-4	NUT	
2	J36010-5	BOLT	
3	J36010-6	WASHER	
4	J36010-7	O-RING	V02697



767

ILLUSTRATED TOOL AND EQUIPMENT MANUAL

PART NUMBER: A36014-1

NAME: PRESSURE TEST EQUIPMENT - DUCT ASSEMBLY

AIRPLANE MAINTENANCE: NO

COMPONENT MAINTENANCE: YES

USAGE & DESCRIPTION: The A36014-1 pressure test equipment is used during component maintenance on all 767 airplanes. A36014 is used to seal flanges 14A545-1,-3 or -11 when pressure testing duct assemblies 213N1100, 213N1101, 213T2103 and 213T2107. Refer to CMM 36-10-06 for complete usage instructions. A36014-1 consists of:

A36014-1		
QUANTITY	NOMENCLATURE	PART NUMBER
2	CLAMP ASSEMBLY	A36014-2
1	CAP	A36014-3
4	WING NUT	A36014-4
4	WASHER	A36014-5
1	O-RING	A36014-6
1	STORAGE BOX	

WEIGHT: 4 lbs (1.8 kg)

DIMENSIONS: 3 x 6 x 6 inches (76 x 152 x 152 mm)

**767
ILLUSTRATED TOOL AND EQUIPMENT MANUAL**

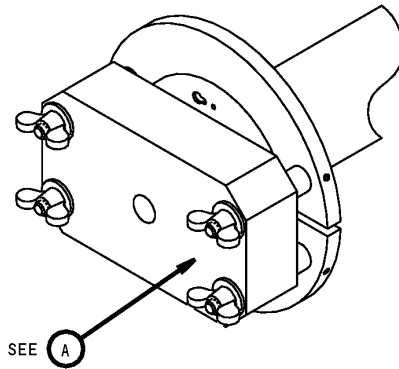

**Duct Assembly Pressure Test Equipment
Figure 1 (Sheet 1 of 2)**

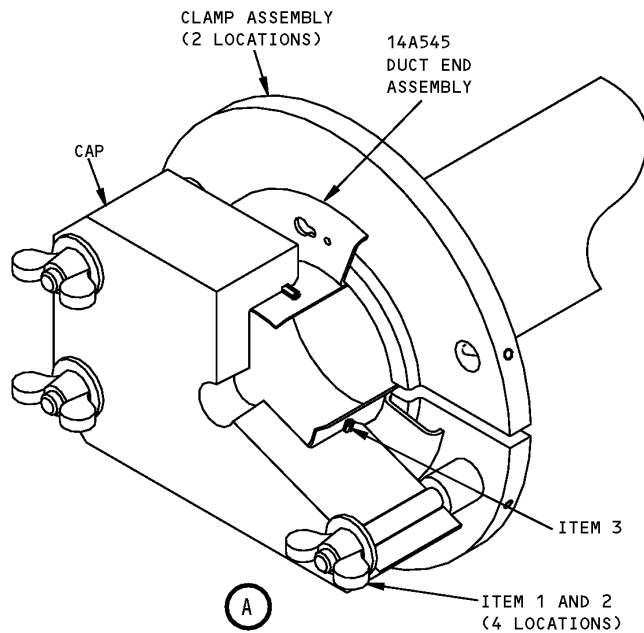

**Duct Assembly Pressure Test Equipment
Figure 1 (Sheet 2 of 2)**



767

ILLUSTRATED TOOL AND EQUIPMENT MANUAL

REPAIRABLE/REPLACEABLE PARTS			
ITEM NO.	PART NO.	NOMENCLATURE	VENDOR CODE
1	A36014-5	WASHER	
2	A36014-4	WING NUT	
3	A36014-6	O-RING	V02697



767

ILLUSTRATED TOOL AND EQUIPMENT MANUAL

PART NUMBER: A36015-1

NAME: PRESSURE TEST EQUIPMENT - DUCT ASSEMBLY

AIRPLANE MAINTENANCE: NO

COMPONENT MAINTENANCE: YES

USAGE & DESCRIPTION: The A36015-1 pressure test equipment is used during component maintenance on all 767 airplanes. A36015 is used to plug the 332T4334-4 flange during hydraulic proof pressure test of the 332T4321 manifold assembly. Refer to CMM 36-10-06 for complete usage instructions. A36015-1 consists of:

A36015-1		
QUANTITY	NOMENCLATURE	PART NUMBER
1	PLUG	A36015-3
1	O-RING	A36015-4
1	STORAGE BOX	

WEIGHT: 2 lbs (0.9 kg)

DIMENSIONS: 2 x 2 x 4 inches (51 X 51 X 102 mm)

767
ILLUSTRATED TOOL AND EQUIPMENT MANUAL

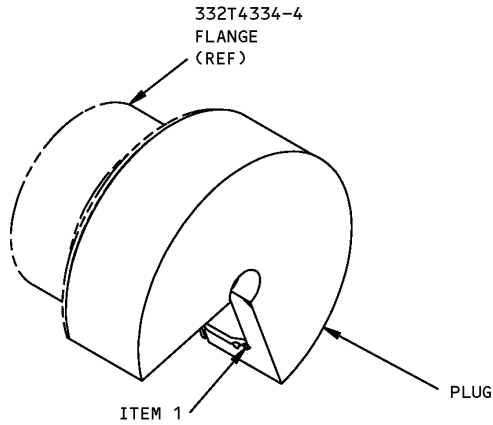

Duct Assembly Pressure Test Equipment
Figure 1

REPAIRABLE/REPLACEABLE PARTS			
ITEM NO.	PART NO.	NOMENCLATURE	VENDOR CODE
1	A36015-4	O-RING	V02697



767

ILLUSTRATED TOOL AND EQUIPMENT MANUAL

PART NUMBER: A36017-1

NAME: PLUG - DUCT, PROOF PRESSURE TEST

AIRPLANE MAINTENANCE: NO

COMPONENT MAINTENANCE: YES

USAGE & DESCRIPTION: The A36017-1 plug is used during component maintenance on all 767 airplanes. A36017 is used to seal the 312U2355-4 or -7 flanges on ducts while performing a hydrostatic pressure test. Refer to CMM 36-10-06 for complete usage information. A36017-1 consists of:

A36017-1		
QUANTITY	NOMENCLATURE	PART NUMBER
2	PLUG	A36017-3
6	NUT	A36017-4
11	BOLT	A36017-5
17	WASHER	A36017-6
2	O-RING	2-226 N674-70
1	STORAGE BOX	

WEIGHT: 1 lb (0.5 kg)

DIMENSIONS: 2 x 4 x 4 inches (51 x 102 x 102 mm))

767
ILLUSTRATED TOOL AND EQUIPMENT MANUAL

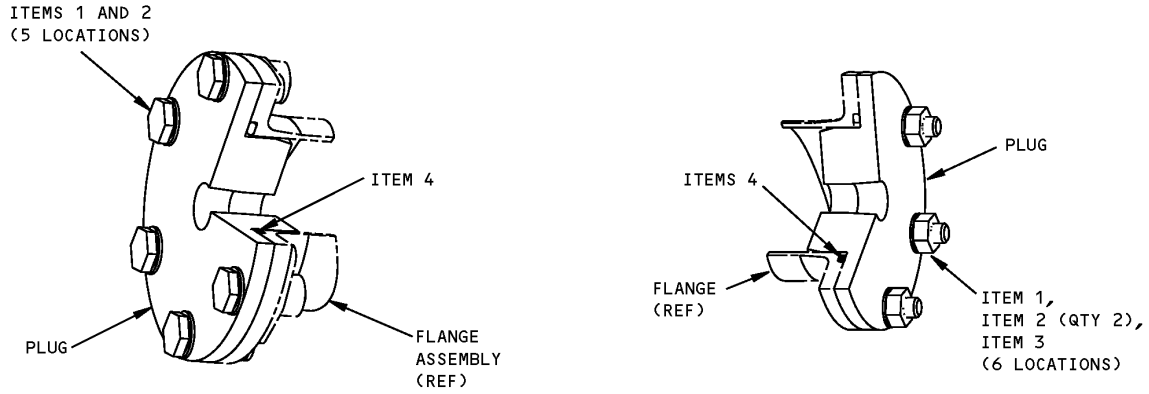

Proof Pressure Test Duct Plug
Figure 1

REPAIRABLE/REPLACEABLE PARTS			
ITEM NO.	PART NO.	NOMENCLATURE	VENDOR CODE
1	A36017-5	BOLT	
2	A36017-6	WASHER	
3	A36017-4	NUT	
4	2-226 N674-70	O-RING	V02697



767

ILLUSTRATED TOOL AND EQUIPMENT MANUAL

PART NUMBER: A36018-1

NAME: PLUG EQUIPMENT - DUCT, PROOF PRESSURE TEST

AIRPLANE MAINTENANCE: NO

COMPONENT MAINTENANCE: YES

USAGE & DESCRIPTION: The A36018-1 plug equipment is used during component maintenance on all 767 airplanes. A36018 is used to plug the retainer 332T3075-1 flange during proof pressure test. Refer to CMM 36-10-06 for complete usage instructions. A36018-1 consists of:

A36018-1		
QUANTITY	NOMENCLATURE	PART NUMBER
1	PLUG ASSEMBLY	A36018-2
1	BEARING NUT	A36018-3
1	STORAGE BOX	

WEIGHT: 3 lbs (1.4 kg)

DIMENSIONS: 4 x 4 inches (102 X 102 mm)

ILLUSTRATED TOOL AND EQUIPMENT MANUAL

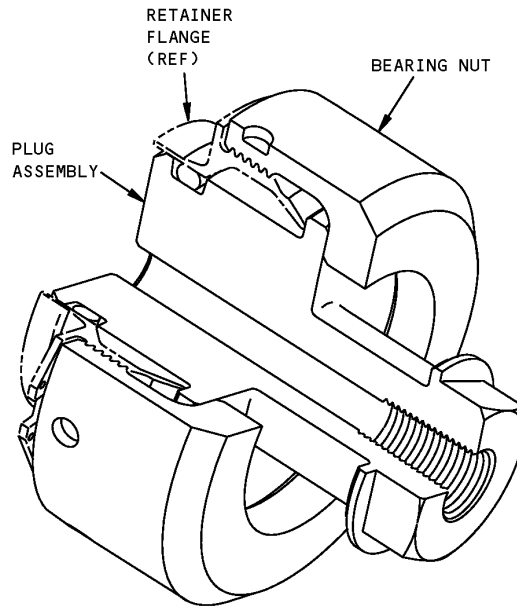

**Proof Pressure Test Duct Plug Equipment
Figure 1**



767

ILLUSTRATED TOOL AND EQUIPMENT MANUAL

PART NUMBER: A36019-1

NAME: PLUG EQUIPMENT - DUCT, PROOF PRESSURE TEST

AIRPLANE MAINTENANCE: NO

COMPONENT MAINTENANCE: YES

USAGE & DESCRIPTION: The A36019-1 plug equipment is used during component maintenance on all 767 airplanes. A36019 is used to plug the 332T4334 flange on the 332T4334 duct during hydrostatic pressure test. Refer to CMM 36-10-06 for complete usage instructions. A36019-1 consists of:

A36019-1		
QUANTITY	NOMENCLATURE	PART NUMBER
1	PLUG ASSEMBLY	A36019-3
2	CLAMP HALF	A36019-4
4	WASHER	A36019-5
2	NUT	A36019-6
2	SCREW	A36019-7
1	STORAGE BOX	

WEIGHT: 4 lbs (1.8 kg)

DIMENSIONS: 5 x 6 x 6 inches (127 x 152 x 152 mm)

ILLUSTRATED TOOL AND EQUIPMENT MANUAL

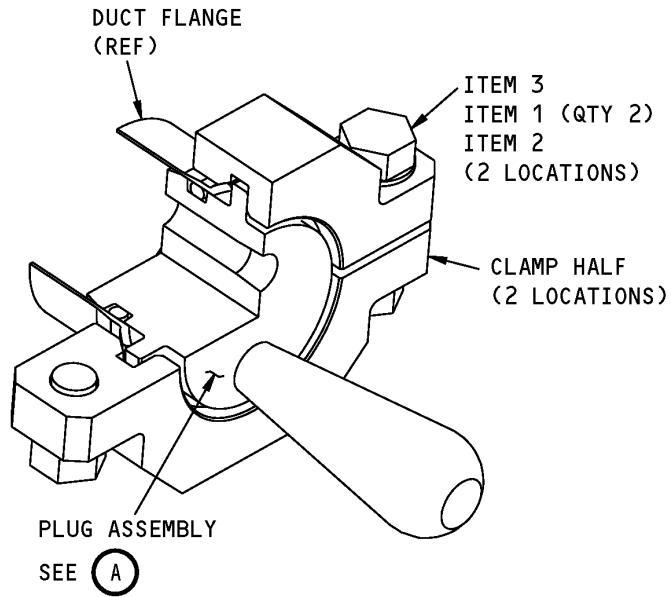

**Proof Pressure Test Duct Plug Equipment
Figure 1 (Sheet 1 of 2)**

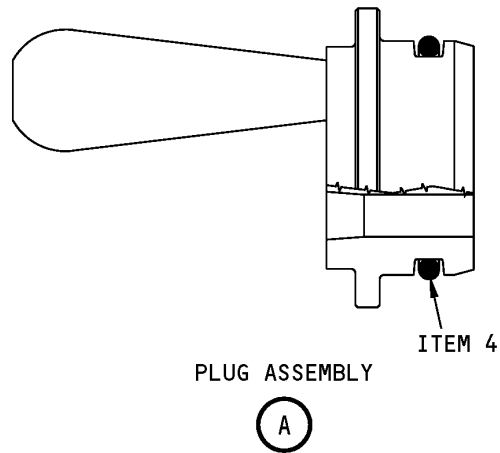

**Proof Pressure Test Duct Plug Equipment
Figure 1 (Sheet 2 of 2)**



767

ILLUSTRATED TOOL AND EQUIPMENT MANUAL

REPAIRABLE/REPLACEABLE PARTS			
ITEM NO.	PART NO.	NOMENCLATURE	VENDOR CODE
1	A36019-5	WASHER	
2	A36019-6	NUT	
3	A36019-7	SCREW	
4	2-230 N552-90	O-RING	V02697



767

ILLUSTRATED TOOL AND EQUIPMENT MANUAL

PART NUMBER: A36020-1

NAME: PLUG EQUIPMENT - DUCTS, PROOF PRESSURE TEST

AIRPLANE MAINTENANCE: NO

COMPONENT MAINTENANCE: YES

USAGE & DESCRIPTION: The A36010-1 plug equipment is used during component maintenance on all 767 airplanes. A36020 is used to plug duct assemblies 218T1100-1 and 218T1101-5 during hydrostatic pressure test. Refer to CMM 36-10-06 for complete usage instructions. A36020-1 consists of:

A36020-1		
QUANTITY	NOMENCLATURE	PART NUMBER
1	YOKE ASSEMBLY	A36020-2
1	COMPRESSION PLUG ASSEMBLY	A36020-3
2	OFFSET CAP ASSEMBLY	A36020-4
1	SHORT SPREADER	A36020-5
1	LOCK-ROD	A36020-6
5	0.500 NUT	A36020-7
1	0.375 NUT	A36020-8
5	0.500 WASHER	A36020-9
2	0.375 WASHER	A36020-10
2	ROUND CAP ASSEMBLY	A36020-11
1	PLUG ASSEMBLY	A36020-12
1	LARGE SPREADER ASSEMBLY	A36020-13
1	CURVED SPACER	A36020-14
1	LONG SPREADER	A36020-15
3	BUSHING	A36020-16
2	O-RING	2-112 N674-70
1	STORAGE BOX	

WEIGHT: 25 lbs (11 kg)

DIMENSIONS: 5 x 7 x 26 inches (127 x 178 x 660 mm)

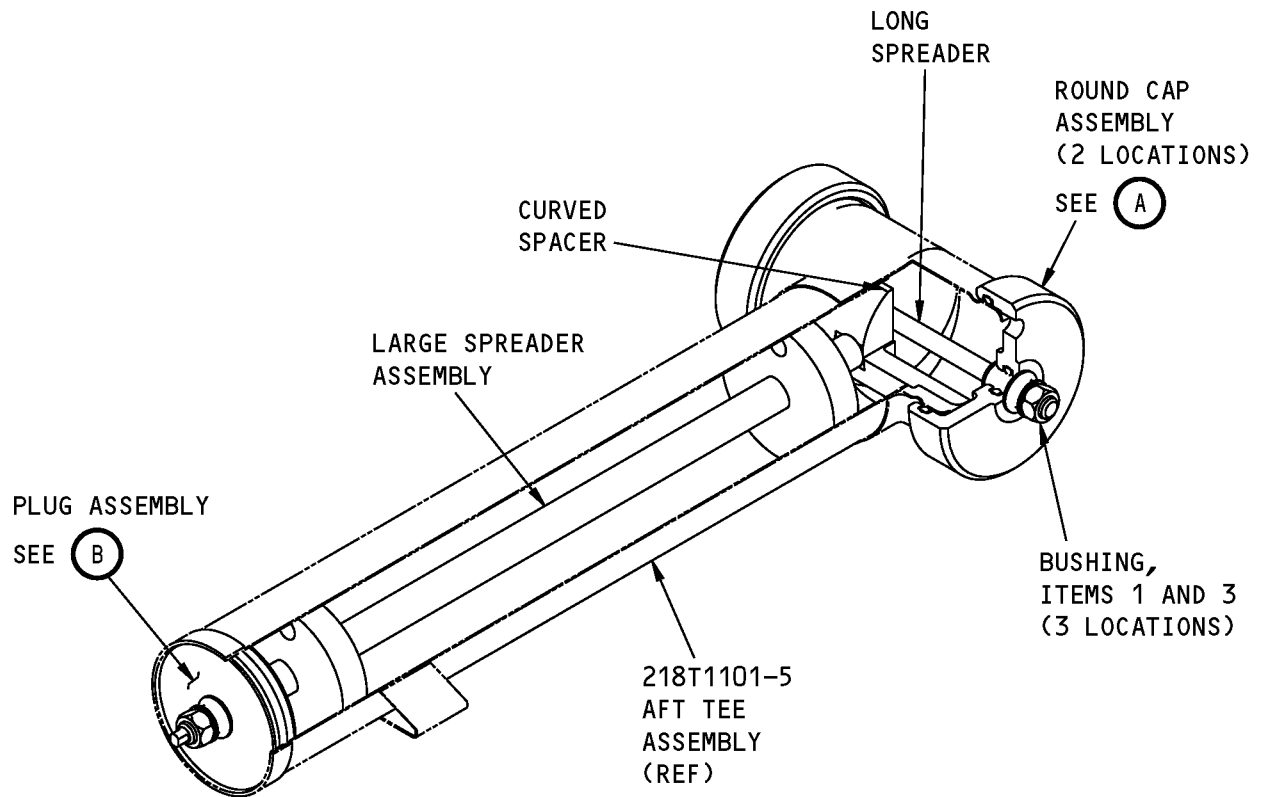

**Proof Pressure Test Ducts Plug Equipment
Figure 1 (Sheet 1 of 3)**

ILLUSTRATED TOOL AND EQUIPMENT MANUAL

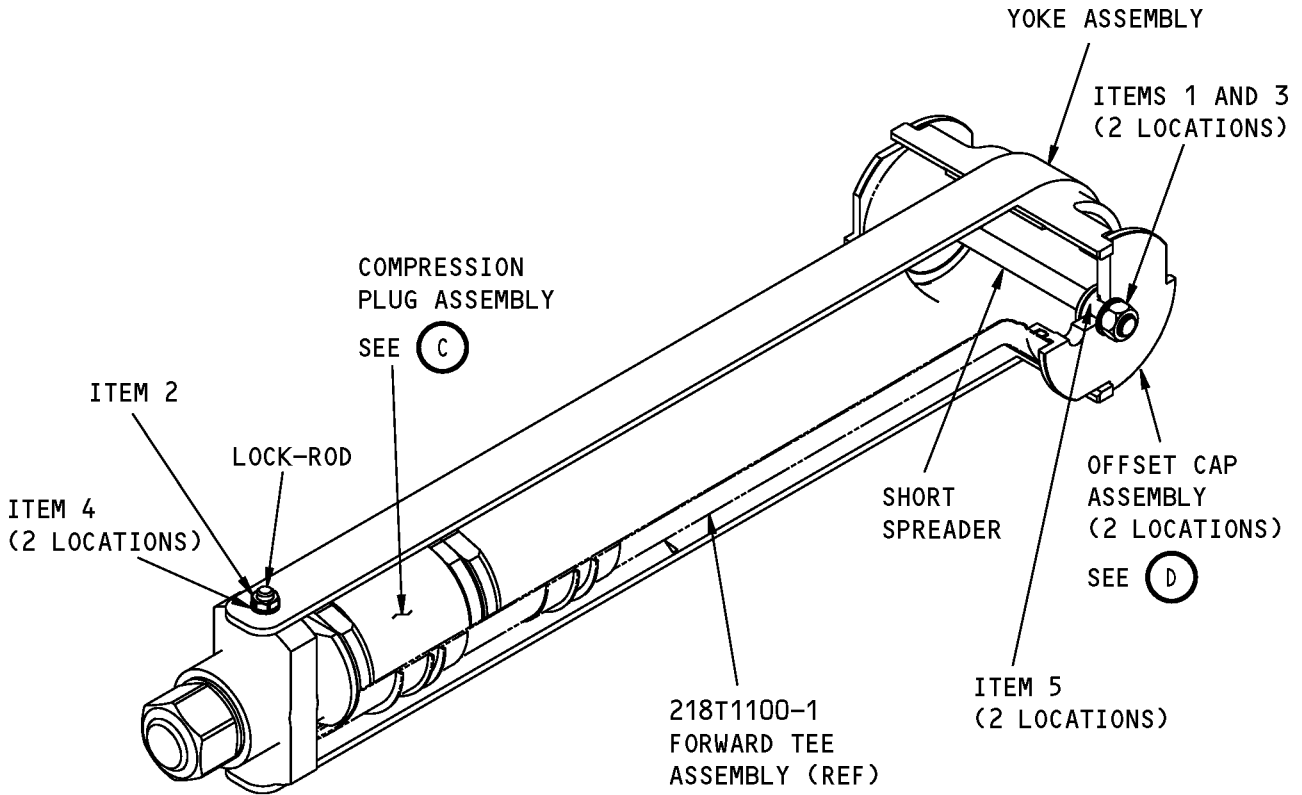

CAUTION: TURN NUT TO COMPRESS SEAL ONLY UNTIL RESISTANCE IS FELT AS SEAL PRESSES AGAINST INSIDE OF TUBE. DO NOT OVER-TIGHTEN.

**Proof Pressure Test Ducts Plug Equipment
Figure 1 (Sheet 2 of 3)**

ILLUSTRATED TOOL AND EQUIPMENT MANUAL

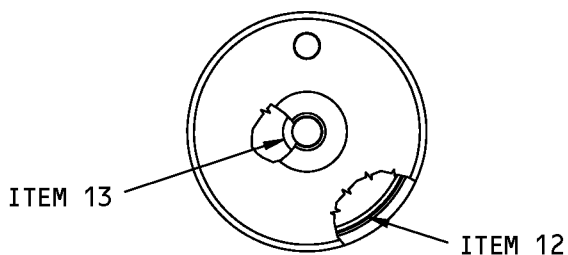

ROUND CAP ASSEMBLY

(A)

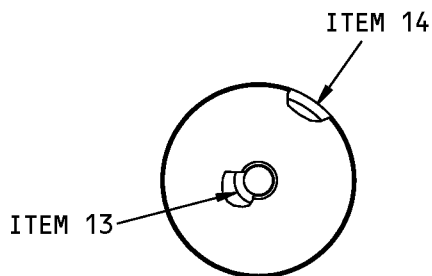

PLUG ASSEMBLY

(B)

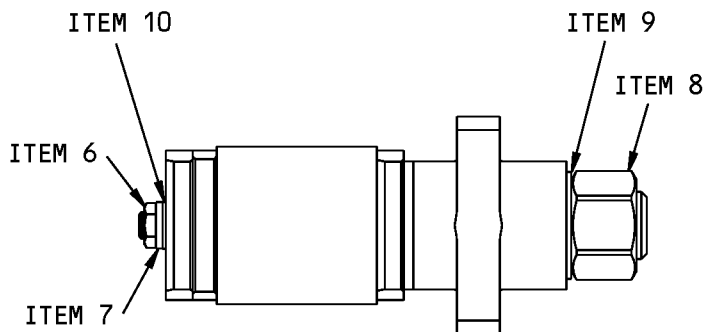

COMPRESSION PLUG ASSEMBLY

(C)

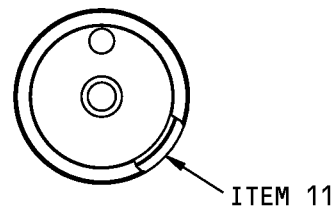

OFFSET CAP ASSEMBLY

(D)

**Proof Pressure Test Ducts Plug Equipment
Figure 1 (Sheet 3 of 3)**



767

ILLUSTRATED TOOL AND EQUIPMENT MANUAL

REPAIRABLE/REPLACEABLE PARTS			
ITEM NO.	PART NO.	NOMENCLATURE	VENDOR CODE
1	A36020-7	0.500 NUT	
2	A36020-8	0.375 NUT	
3	A36020-9	0.500 WASHER	
4	A36020-10	0.375 WASHER	
5	2-112 N674-70	O-RING	V02697
6	A36020-24	JAM NUT	
7	A36020-25	LOCK WASHER	
8	A36020-31	NUT	
9	A36020-32	WASHER	
10	A36020-33	WASHER	
11	2-336 N674-70	O-RING	V02697
12	2-343 N674-70	O-RING	V02697
13	2-311 N674-70	O-RING	V02697
14	2-339 N674-70	O-RING	V02697



767

ILLUSTRATED TOOL AND EQUIPMENT MANUAL

PART NUMBER: A36022-1

NAME: REMOVAL/INSTALLATION EQUIPMENT - RB211 PRECOOLER

AIRPLANE MAINTENANCE: YES

COMPONENT MAINTENANCE: NO

USAGE & DESCRIPTION: The A36022-1 removal/installation equipment is used on 767 airplanes equipped with RB211 engines. A36022 is used to remove or install the precooler with the RB211 engine installed on the airplane. Refer to the current A36022 drawing and AMM 36-11-15 for complete usage instructions. A36022 consists of:

A36022-1		
QUANTITY	NOMENCLATURE	PART NUMBER
1	ROLLER ASSEMBLY	A36022-2
1	SHELF ASSEMBLY	A36022-3
1	SHELF ASSEMBLY	A36022-4
1	PLATE ASSEMBLY	A36022-5
1	PLATE ASSEMBLY	A36022-6
1	ROD ASSEMBLY	A36022-7
1	ATTACH PLATE ASSEMBLY	A36022-8
1	HAND KNOB ASSEMBLY	A36022-9
1	STORAGE BOX	

WEIGHT: 72 lbs (33 kg)

DIMENSIONS: 12 x 20 x 42 inches (305 x 508 x 1067 mm)

ILLUSTRATED TOOL AND EQUIPMENT MANUAL

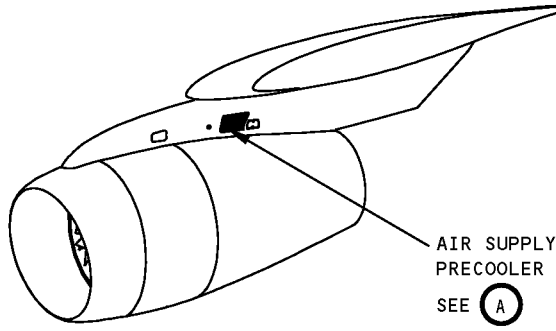

**RB211 Precooler Removal/Installation Equipment
Figure 1 (Sheet 1 of 2)**

ILLUSTRATED TOOL AND EQUIPMENT MANUAL

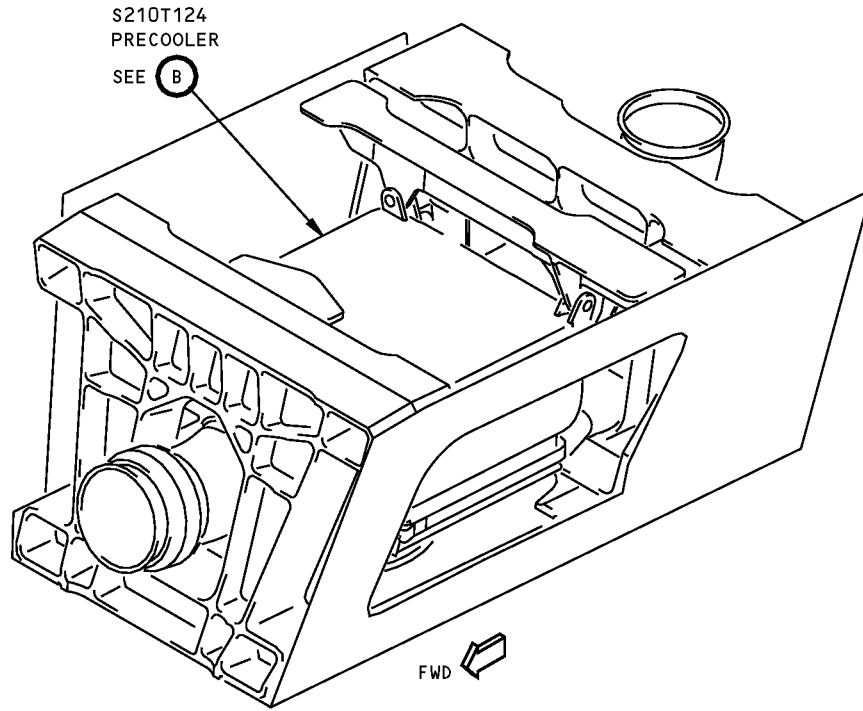

AIR SUPPLY PRECOOLER

(A)

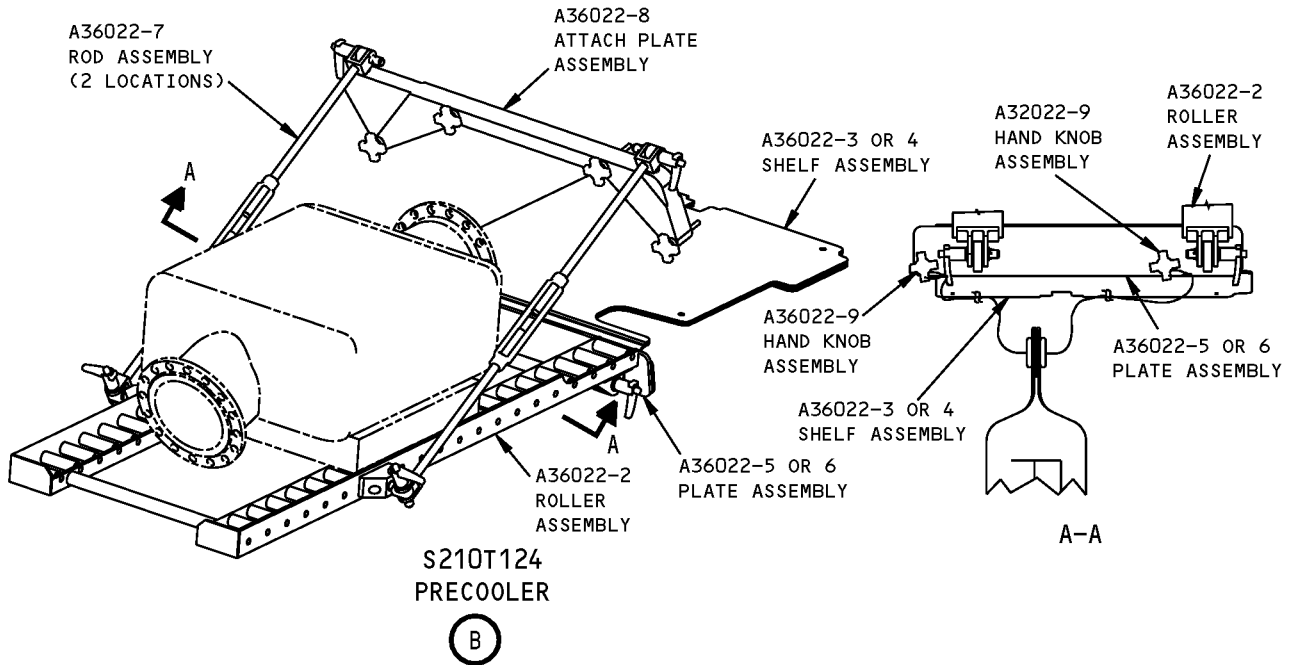

**RB211 Precooler Removal/Installation Equipment
Figure 1 (Sheet 2 of 2)**