

CHAPTER

52

DOORS



767
ILLUSTRATED TOOL AND EQUIPMENT MANUAL

CHAPTER 52
DOORS

Subject/Page	Date	Subject/Page	Date	Subject/Page	Date
EFFECTIVE PAGES		52-10-09		52-30-08	
1 thru 2	Oct 10/2008	1	Apr 10/2006	1	Apr 10/2006
		2	BLANK	2	Apr 10/2006
52-CONTENTS		52-10-10		52-30-09	
1	Apr 10/2008	1	Apr 10/2006	1	Oct 10/2007
2	Apr 10/2006	2	BLANK	2	Apr 10/2006
52-00-01		52-20-01		52-30-10	
1	Apr 10/2006	1	Apr 10/2006	1	Apr 10/2006
2	BLANK	2	Apr 10/2006	2	Apr 10/2006
52-00-02		52-20-02		3	Apr 10/2006
1	Apr 10/2006	1	Apr 10/2007	4	BLANK
2	BLANK	2	Apr 10/2007	52-30-11	
52-10-01		3	Apr 10/2007	1	Apr 10/2006
1	Apr 10/2006	4	BLANK	2	BLANK
2	Apr 10/2007	52-30-01		52-30-12	
3	Apr 10/2007	1	Apr 10/2006	1	Apr 10/2006
4	Apr 10/2006	2	Apr 10/2006	2	Apr 10/2006
52-10-02		52-30-02		52-30-13	
1	Apr 10/2006	1	Oct 10/2006	1	Apr 10/2006
2	Apr 10/2006	2	Oct 10/2006	2	Apr 10/2006
52-10-03		3	Apr 10/2006	3	Apr 10/2006
1	Apr 10/2006	4	BLANK	4	BLANK
2	Apr 10/2006	52-30-03		52-30-14	
52-10-04		1	Apr 10/2006	1	Oct 10/2007
1	Apr 10/2007	2	Apr 10/2006	2	Apr 10/2006
2	Apr 10/2007	3	Apr 10/2006	3	Apr 10/2006
3	Apr 10/2007	4	Apr 10/2006	4	BLANK
4	BLANK	52-30-04		52-30-15	
52-10-05		1	Apr 10/2006	1	Apr 10/2008
1	Oct 10/2007	2	Apr 10/2006	2	BLANK
2	Apr 10/2006	52-30-05		52-30-16	
52-10-06		1	Apr 10/2006	R 1	Oct 10/2008
1	Apr 10/2006	2	BLANK	2	BLANK
2	Apr 10/2006	52-30-06		52-30-17	
52-10-07		1	Apr 10/2006	1	Oct 10/2006
1	Apr 10/2006	2	Apr 10/2006	2	BLANK
2	BLANK	52-30-07		52-30-18	
52-10-08		1	Apr 10/2006	1	Oct 10/2007
1	Apr 10/2006	2	BLANK	2	Apr 10/2006
2	BLANK				

A = Added, R = Revised, O = Overflow, D = Deleted

52-EFFECTIVE PAGES



767
ILLUSTRATED TOOL AND EQUIPMENT MANUAL

CHAPTER 52
DOORS

Subject/Page	Date	Subject/Page	Date	Subject/Page	Date
52-30-19					
1	Oct 10/2007				
2	Apr 10/2006				
52-30-20					
1	Apr 10/2006				
2	Apr 10/2006				
52-30-21					
1	Apr 10/2006				
2	Apr 10/2006				
52-40-01					
1	Apr 10/2006				
2	Apr 10/2006				
52-40-02					
1	Apr 10/2006				
2	BLANK				
52-40-03					
1	Apr 10/2006				
2	Apr 10/2006				
3	Apr 10/2006				
4	BLANK				
52-50-01					
1	Oct 10/2006				
2	Apr 10/2006				

A = Added, R = Revised, O = Overflow, D = Deleted

52-EFFECTIVE PAGES

Page 2
Oct 10/2008

D634T501



767

ILLUSTRATED TOOL AND EQUIPMENT MANUAL

TABLE OF CONTENTS

<u>Subject</u>	<u>Title</u>	<u>Part No.</u>
52-	DOORS	
52-00-02	INSTALLATION TOOL - DOOR SEAL	B52004-1
52-10-01	SAFETY BARRIER - ENTRY, MID-ENTRY OR SERVICE DOOR	A52002-1, -13
52-10-02	TEST EQUIPMENT - LATCH LOCK, LARGE CARGO DOOR LATCH LOCK	A52018-1, -15
52-10-03	LOCK - COUNTERBALANCE, ENTRY AND SERVICE DOORS	A52003-1
52-10-04	GROUND LOCK - ENTRY/SERVICE DOOR	A52008-14
52-10-05	DUMMY WEIGHT SLIDE PACK - PASSENGER AND SERVICE DOOR	A52013-31
52-10-06	TEST FIXTURE - GEARBOX, OVERHEAD PASSENGER DOOR COUNTERBALANCE	A52017-1
52-10-07	MANDREL EQUIPMENT - BEARING INSTALLATION	A52020-1
52-10-08	CANOPY - FORWARD ENTRY DOOR	A52022-1
52-10-09	STAKING EQUIPMENT - GIRT BAR BEARING	A52030-1
52-10-10	SHAFT SUPPORT - COUNTERBALANCE, OVERHEAD PASSENGER DOOR	A52015-1, -3
52-20-01	SAFETY BARRIER - AFT EMERGENCY EXIT	A52027-1
52-20-02	GAGE - GIRT BAR, CARRIER DRIVE	A52029-1
52-30-01	SAFETY BARRIER - CARGO DOOR, FORWARD/AFT	A52005-1
52-30-02	SLING EQUIPMENT - DOOR HANDLING	A52004-41, -42, -43
52-30-03	REPLACEMENT EQUIPMENT - BULK CARGO DOOR	A52006-1
52-30-04	SAFETY BARRIER - FORWARD LARGE CARGO DOOR	A52007-1
52-30-05	TEST FIXTURE - BUNGEE SPRING, CARGO DOOR	A52009-1, -22
52-30-06	CLAMP EQUIPMENT - SPRING INSTALLATION/REMOVAL, BULK CARGO DOOR	A52010-50, -51
52-30-08	ADJUSTMENT SET - MAIN LATCH PIN, LARGE CARGO DOORS	A52014-1
52-30-09	RIGGING ADJUSTMENT EQUIPMENT - FORWARD AND AFT CARGO DOORS	A52016-1
52-30-10	DRIVER SET - HINGE PIN, LARGE CARGO DOOR	A52019-1
52-30-11	WRENCH - PROXIMITY SENSOR, BULK CARGO DOOR	A52021-1
52-30-12	BACKLASH CHECK EQUIPMENT - MANUAL DRIVE, LARGE CARGO DOOR	A52023-1
52-30-13	VERIFICATION EQUIPMENT - MAIN LATCH FITTINGS, LARGE CARGO DOOR	A52028-1
52-30-14	RIGGING EQUIPMENT - MAIN DECK CARGO DOOR	A52031-1
52-30-15	ADJUSTMENT TOOL SET - LATCH PINS, MAIN DECK CARGO DOOR	A52032-17
52-30-16	PERSONNEL SAFETY BARRIER - MAIN DECK CARGO DOOR	F70258-1

52-CONTENTS



767

ILLUSTRATED TOOL AND EQUIPMENT MANUAL

<u>Subject</u>	<u>Title</u>	<u>Part No.</u>
52-30-17	TORQUE WRENCH ADAPTER - BRAKES, SIDE CARGO DOOR	ME65B83635
52-30-18	VERIFICATION EQUIPMENT - MAIN LATCH FITTINGS, MAIN DECK CARGO DOOR	A52033-1
52-30-19	SLING EQUIPMENT - MAIN DECK CARGO DOOR	A52036-1
52-30-20	RIGGING EQUIPMENT - ROTARY ACTUATOR, MAIN DECK CARGO DOOR	A52034-1
52-30-21	DRIVER EQUIPMENT - INTERMEDIATE HINGE PINS, MAIN DECK CARGO DOOR	A52035-1
52-40-01	SAFETY BARRIER - ELECTRICAL/ELECTRONIC (E/E) ACCESS HATCH	A53002-5
52-40-02	SERVICE PLATFORM - SERVICE ACCESS DOOR	A52025-1
52-40-03	TEST EQUIPMENT - LATCH ASSEMBLY, BLOW OUT DOORS	J52024-2, -3
52-50-01	TEST BOX - FLIGHT DECK ACCESS SYSTEM (FDAS)	A52037-1

52-CONTENTS

Page 2
Apr 10/2006

D634T501



767

ILLUSTRATED TOOL AND EQUIPMENT MANUAL

PART NUMBER: PRE012T2000 WAS DELETED

ILLUSTRATED TOOL AND EQUIPMENT MANUAL

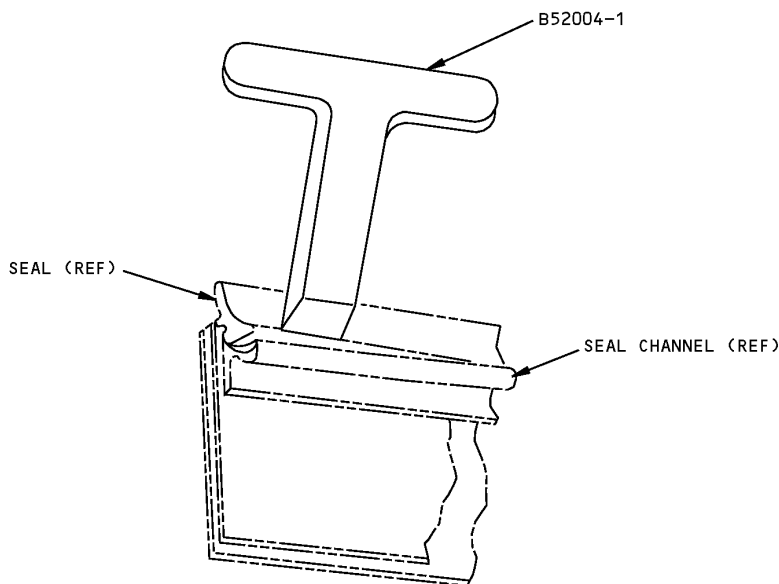
PART NUMBER: B52004-1**NAME:** INSTALLATION TOOL - DOOR SEAL**AIRPLANE MAINTENANCE:** YES**COMPONENT MAINTENANCE:** YES**USAGE & DESCRIPTION:** This tool is a T-handle device that is used to push the door seals into position in the door seal channel on exterior access and entry doors. Refer to Airplane Maintenance Manual 52-00-00 for complete usage instructions.**WEIGHT:** 1 lb (0.5 kg)**DIMENSIONS:** 1 x 5 x 5 inches (25 x 127 x 127 mm)

**Door Seal Installation Tool
Figure 1**



767

ILLUSTRATED TOOL AND EQUIPMENT MANUAL

PART NUMBER: A52002-1, -13

NAME: SAFETY BARRIER - ENTRY, MID-ENTRY OR SERVICE DOOR

AIRPLANE MAINTENANCE: YES

COMPONENT MAINTENANCE: NO

USAGE & DESCRIPTION: This tool is used to prevent injury to personnel. The tool locks over the service or entry door when the door is opened or removed and the loading/unloading apparatus is not in use. The tool is a lightweight aluminum frame across which webbing is secured.

WEIGHT: 22 lbs (10 kg)

DIMENSIONS: 2 x 46 x 65 inches (51 x 1168 x 1651 mm)

NOTE: A52002-13 replaces A52002-1 for future procurement.

ILLUSTRATED TOOL AND EQUIPMENT MANUAL

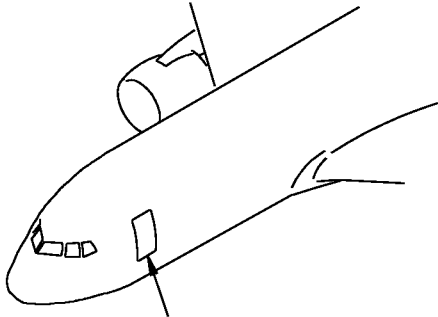

ENTRY/MID-ENTRY/SERVICE DOOR
(4 LOCATIONS -200/-200ER/-300/-300ER)
(6 LOCATIONS -300/-300ER/-400ER)

SEE (A)

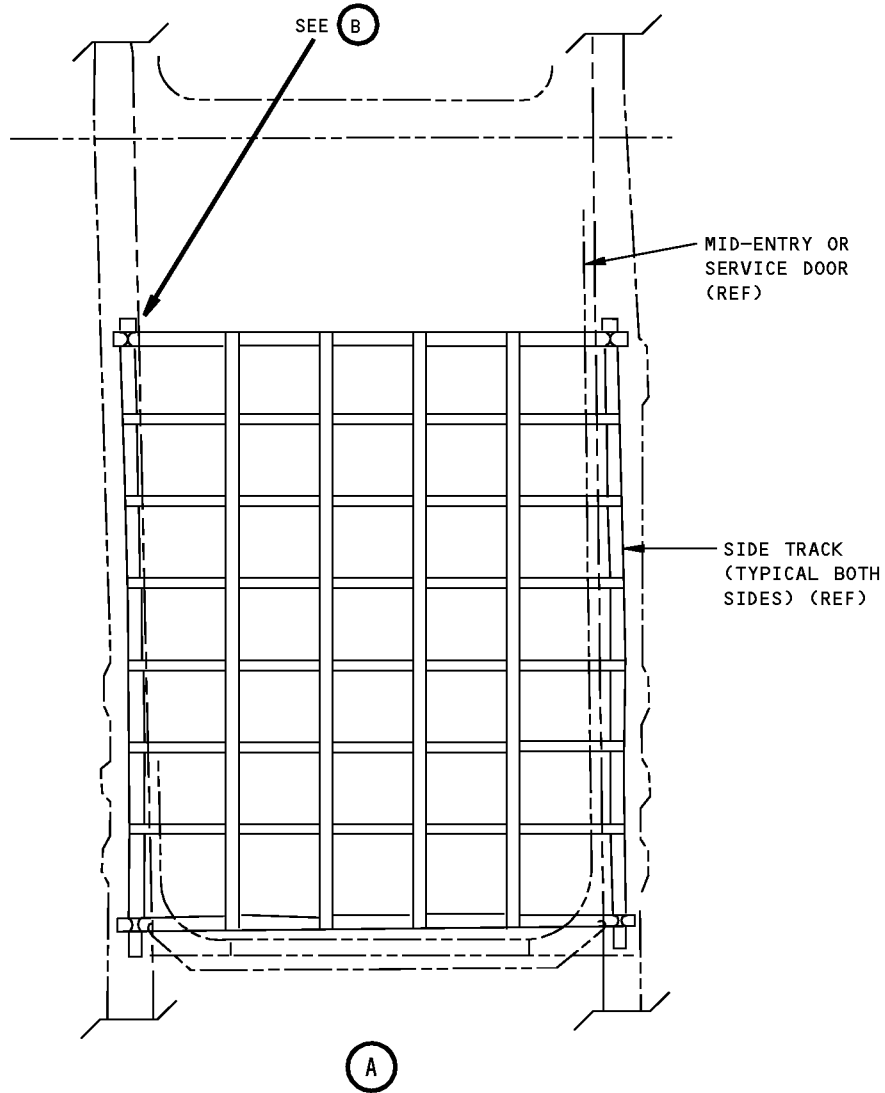

**Entry, Mid-Entry Or Service Door Safety Barrier
Figure 1 (Sheet 1 of 2)**

ILLUSTRATED TOOL AND EQUIPMENT MANUAL

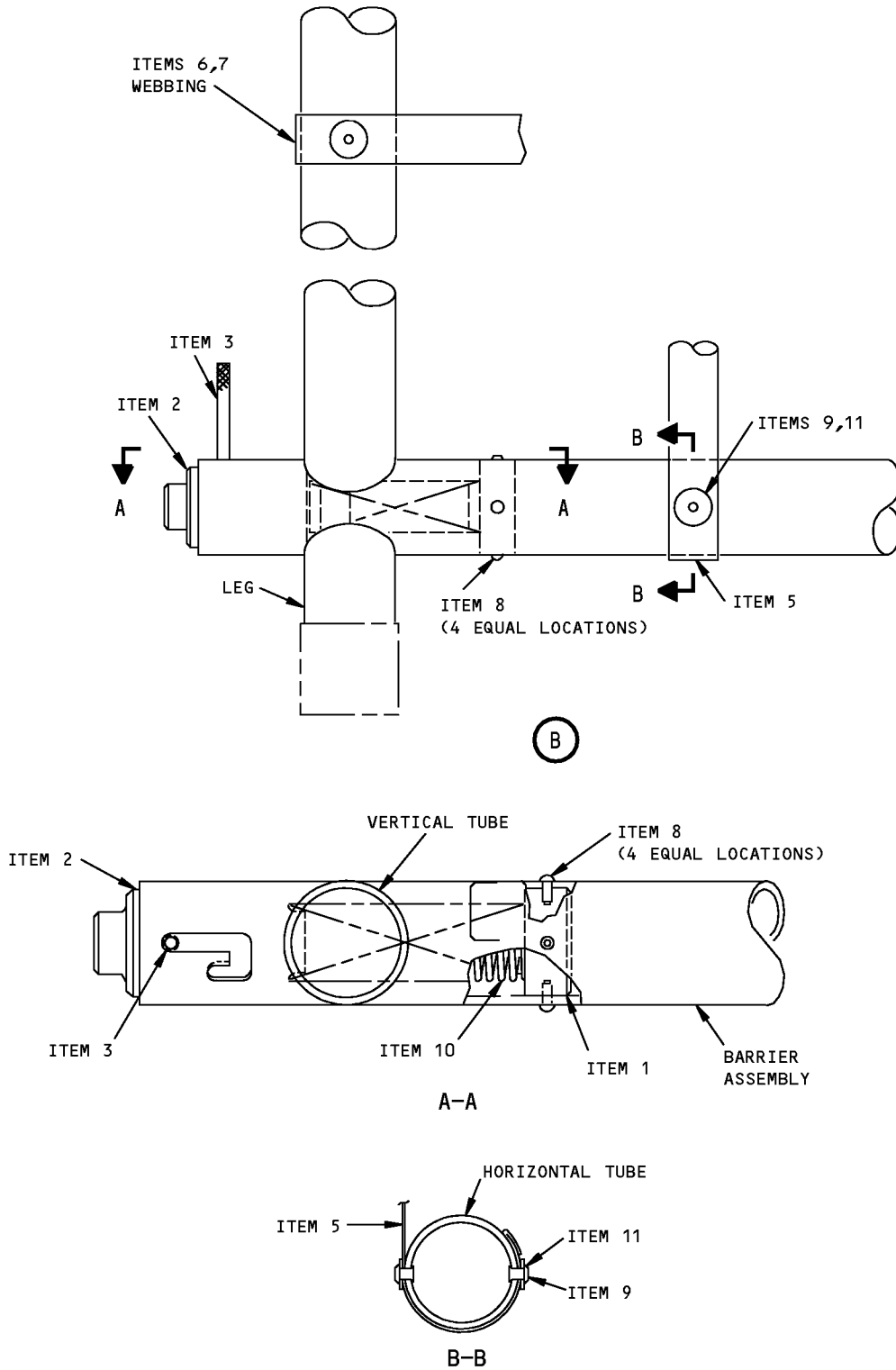

**Entry, Mid-Entry Or Service Door Safety Barrier
Figure 1 (Sheet 2 of 2)**



767

ILLUSTRATED TOOL AND EQUIPMENT MANUAL

REPAIRABLE/REPLACEABLE PARTS			
ITEM NO.	PART NO.	NOMENCLATURE	VENDOR CODE
1	A52022-6	PLUG	
2	A52022-7	SLIDE	
3	A52022-8	HANDLE	
4	A52022-9	END FITTING	
5	A52022-10	WEBBING	
6	A52022-11	WEBBING	
7	A52022-12	WEBBING ASSEMBLY	
8	MS21318-29	DRIVE SCREW	
9	AN960D9	WASHER	
10	C-1225-096-4000	SPRING	V92830
11	NAS1398D6-5	RIVET	



767

ILLUSTRATED TOOL AND EQUIPMENT MANUAL

PART NUMBER: A52018-1, -15

NAME: TEST EQUIPMENT - LATCH LOCK, LARGE CARGO DOOR LATCH LOCK

AIRPLANE MAINTENANCE: NO

COMPONENT MAINTENANCE: YES

USAGE & DESCRIPTION: The A52018 test equipment is used on 767-200, -200ER, -300 and -300ER airplanes. A52018 is used to hold the handle mechanism for testing engagement or disengagement torque. The equipment consists of a test frame assembly and a latch adapter

WEIGHT: 16 lbs (7 kg)

DIMENSIONS: 8 x 10 x 19 inches (203 x 254 x 483 mm)

NOTE: A52018-15 replaces A52018-1 for future procurement.

767
ILLUSTRATED TOOL AND EQUIPMENT MANUAL

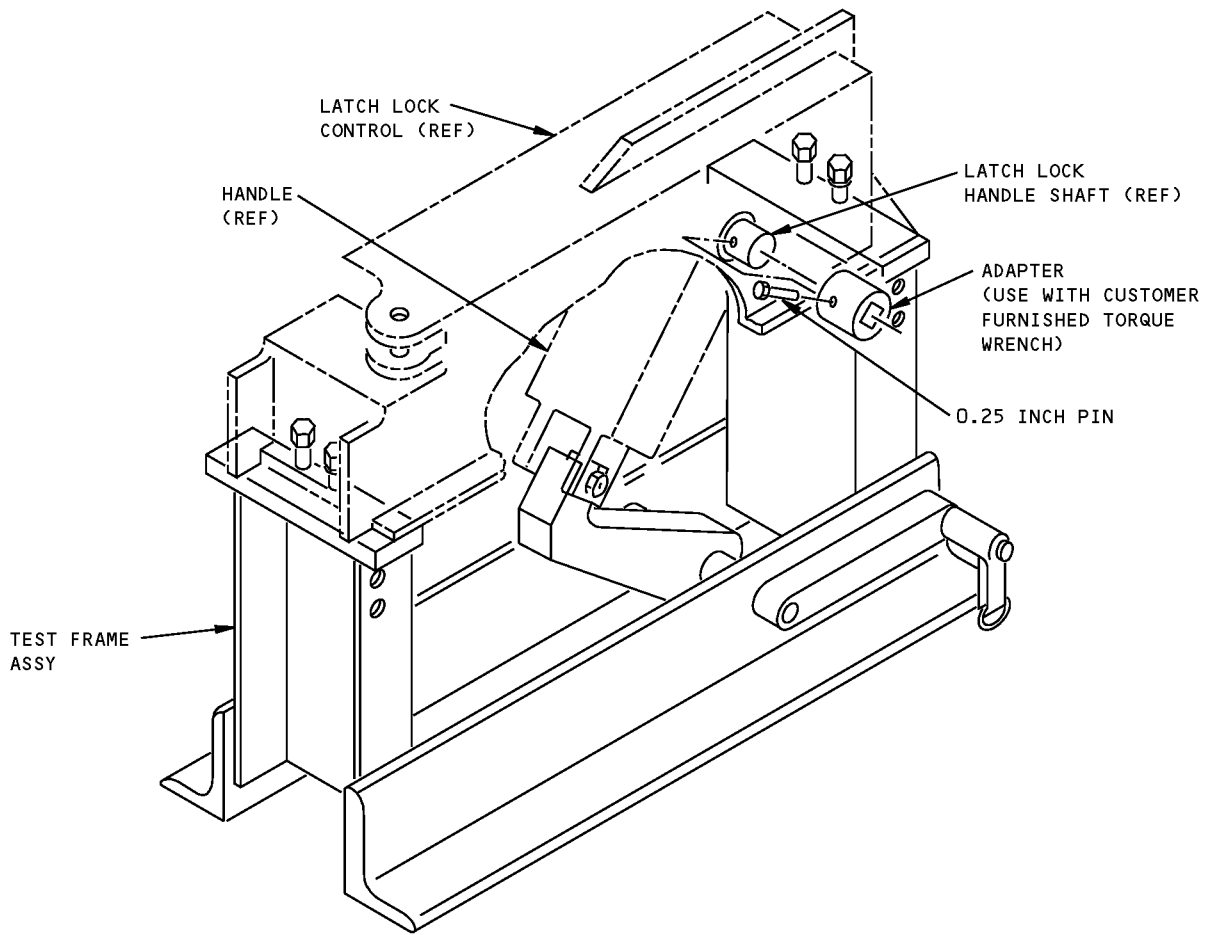

Latch Lock, Large Cargo Door Latch Lock Test Equipment
Figure 1



767

ILLUSTRATED TOOL AND EQUIPMENT MANUAL

PART NUMBER: A52003-1

NAME: LOCK - COUNTERBALANCE, ENTRY AND SERVICE DOORS

AIRPLANE MAINTENANCE: YES

COMPONENT MAINTENANCE: YES

USAGE & DESCRIPTION: This tool is a basic lock pin designed to secure the counterbalance in a fixed position when the service and entry doors are removed.

WEIGHT: 1 lb (0.5 kg)

DIMENSIONS: 4 x 4 x 6 inches (102 x 102 x 152 mm)

767
ILLUSTRATED TOOL AND EQUIPMENT MANUAL

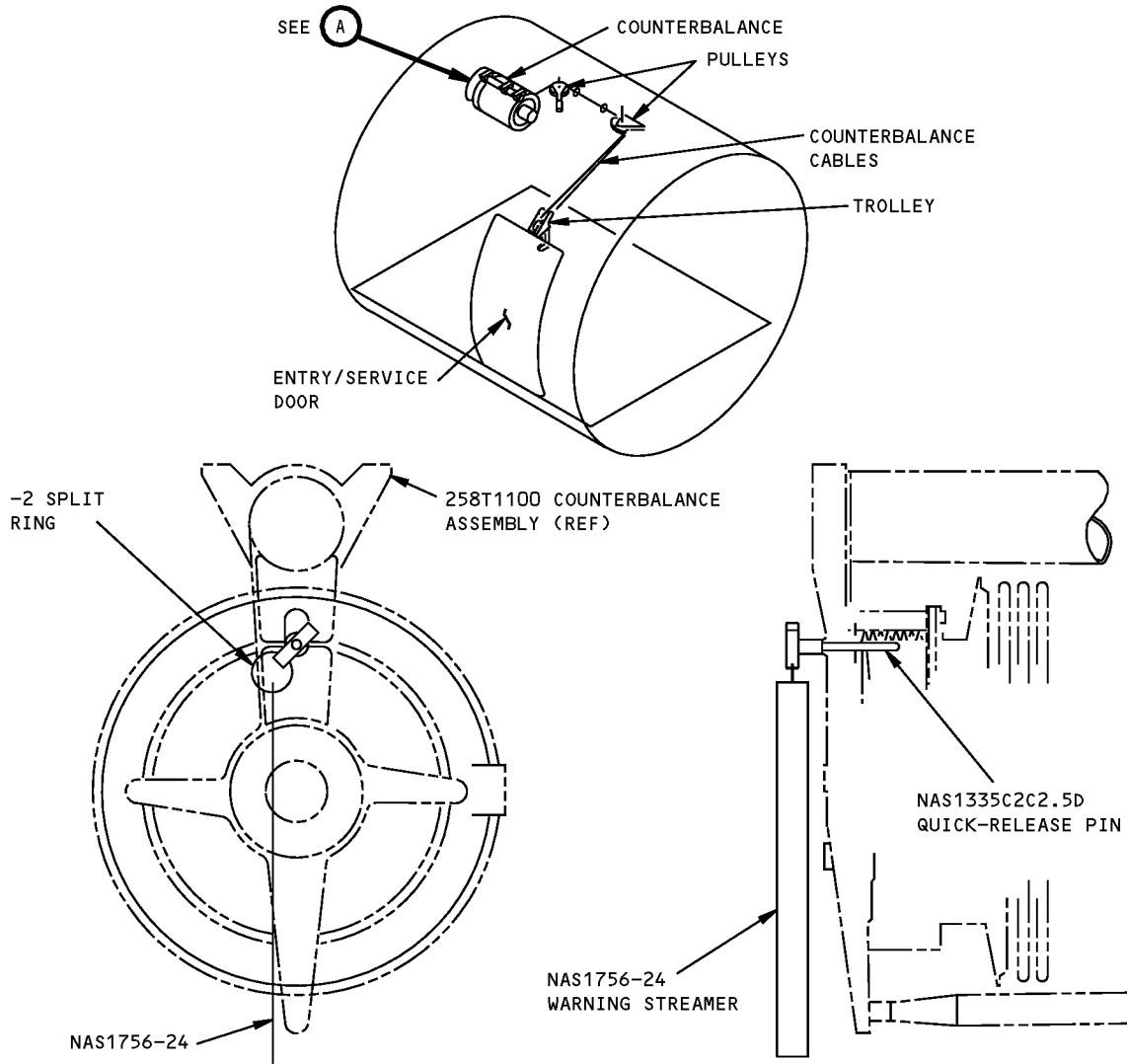

Entry And Service Doors Counterbalance Lock
Figure 1



767

ILLUSTRATED TOOL AND EQUIPMENT MANUAL

PART NUMBER: A52008-14

NAME: GROUND LOCK - ENTRY/SERVICE DOOR

AIRPLANE MAINTENANCE: YES

COMPONENT MAINTENANCE: NO

USAGE & DESCRIPTION: The A52008-14 entry/service door ground lock is used on all 767 airplanes. The tool is used to prevent the entry/service door opening from the outside while personnel are working on the counterbalance hoist. Refer to AMM 52-11-13 and current A52008 drawing for additional usage instructions. The A52008-14 consists of a -15 aft pin assembly and a -16 forward pin assembly and a storage box assembly. The -15 pin assembly is a straight pin used for the aft entry/service doors. The -16 pin assembly is a hinged spring pin to clear electrical wiring on the forward entry/service doors. The A52008-14 is a recommended spares item.

WEIGHT: 1 lb (0.5 kg)

DIMENSIONS: 2 x 6 x 6 inches (51 x 152 x 152 mm)

NOTE: A52008-14 supersedes A52008-10.

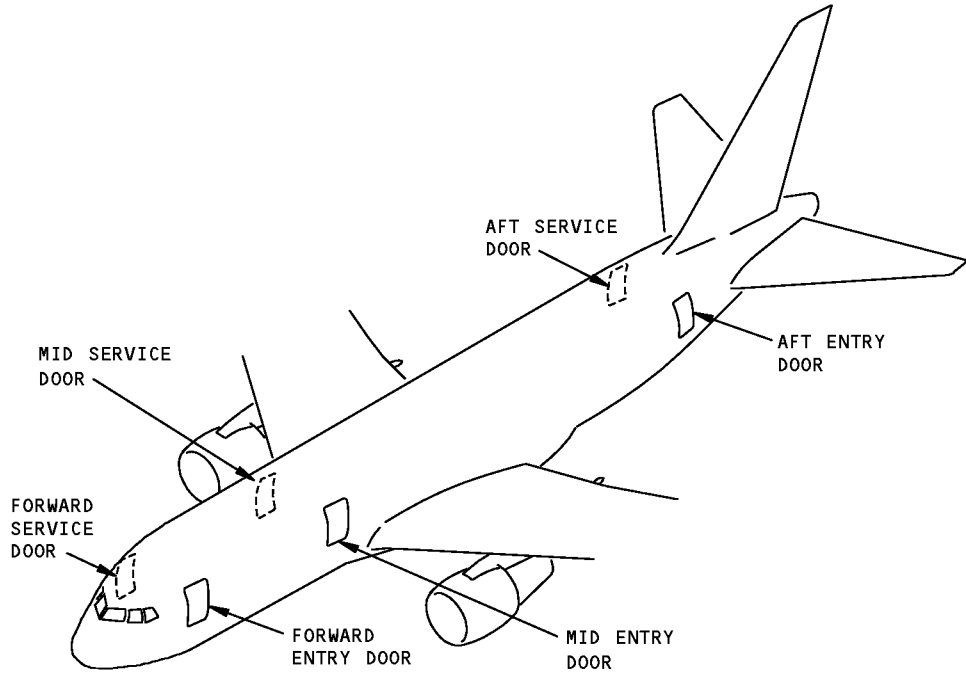

Entry/Service Door Locations
Figure 1

ILLUSTRATED TOOL AND EQUIPMENT MANUAL

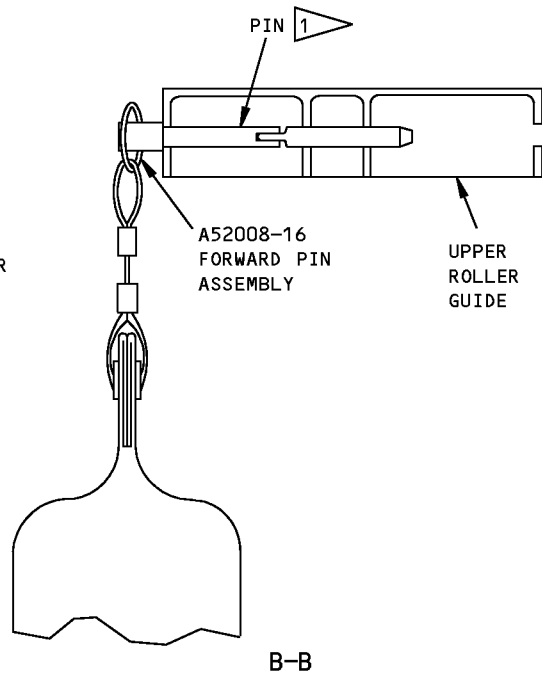
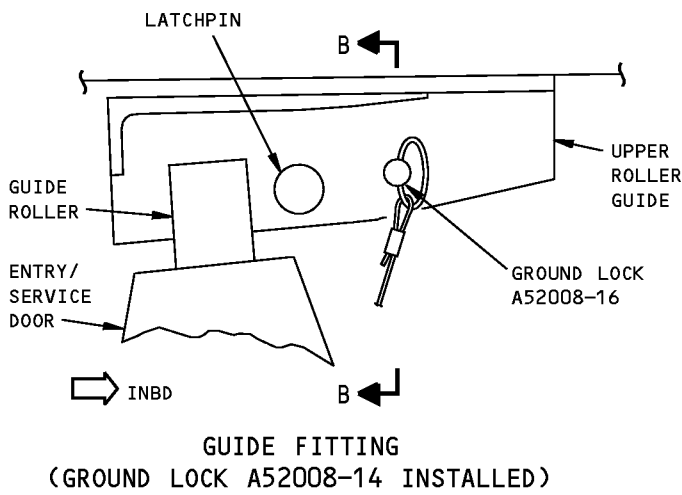
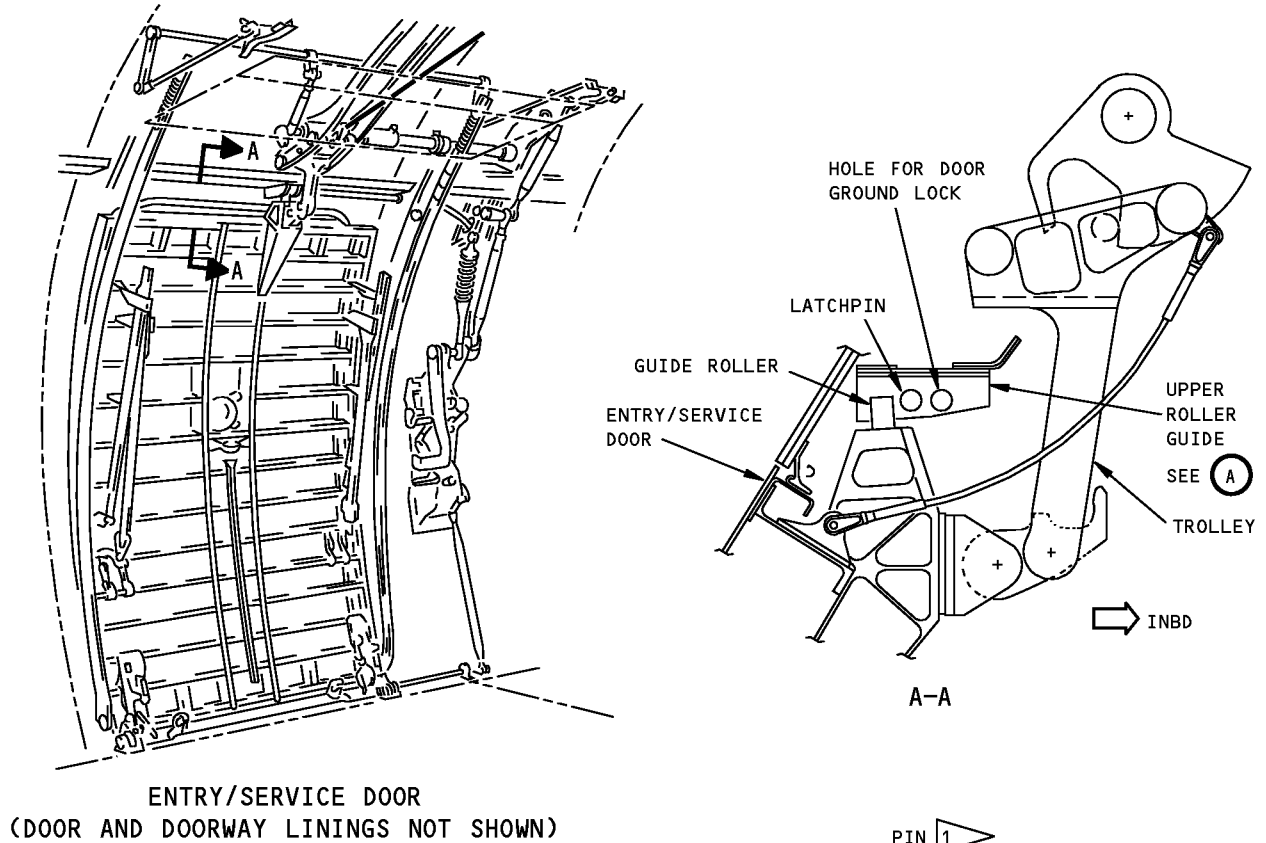

1 ▲ A52008-15 AFT PIN ASSEMBLY HAS STRAIGHT PIN

**Entry/Service Door Ground Locks
Figure 2**



767

ILLUSTRATED TOOL AND EQUIPMENT MANUAL

PART NUMBER: A52013-31

NAME: DUMMY WEIGHT SLIDE PACK - PASSENGER AND SERVICE DOOR

AIRPLANE MAINTENANCE: YES

COMPONENT MAINTENANCE: NO

USAGE & DESCRIPTION: The A52013-31 dummy weight slide pack is used on 767-200, -200ER, -300, -300ER and -400ER airplanes. A52013 is used during maintenance procedures to simulate various escape slide installations. A52013-31 consists of an A52013-30 frame assembly and an A52018-29 box assembly (which includes weights).

WEIGHT: A52013-30 - 35 lbs (16 kg)
A52013-29 - 280 lbs (127 kg)

DIMENSIONS: A52013-30 - 5 X 36 X 40 inches (127 x 914 x 1016 mm)
A52013-29 - 4 x 20 x 24 inches (102 x 508 x 1016 mm)

NOTE: A52013-31 supersedes A52013-1.

767
ILLUSTRATED TOOL AND EQUIPMENT MANUAL

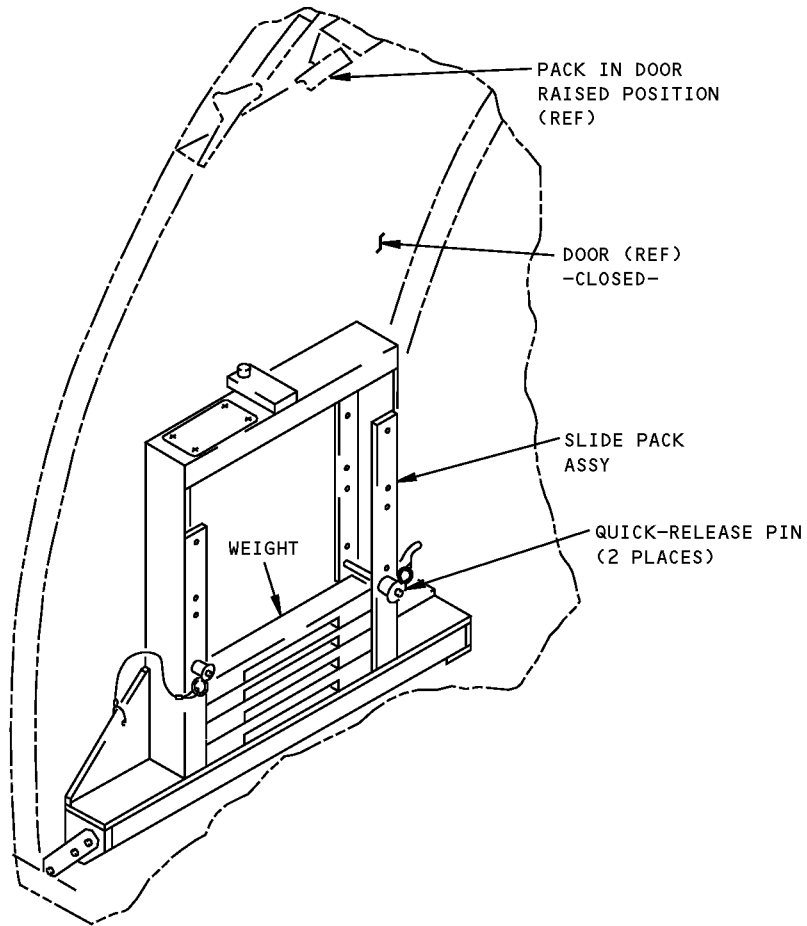

Passenger and Service Door Dummy Weight Slide Pack
Figure 1



767

ILLUSTRATED TOOL AND EQUIPMENT MANUAL

PART NUMBER: A52017-1

NAME: TEST FIXTURE - GEARBOX, OVERHEAD PASSENGER DOOR COUNTERBALANCE

AIRPLANE MAINTENANCE: NO

COMPONENT MAINTENANCE: YES

USAGE & DESCRIPTION: This tool is used in conjunction with the A27081 test box to measure rpm and dynamic torque on the gearbox assembly of the overhead passenger door counterbalance. Refer to CMM 52-11-71 for further usage instructions. This tool consists of a test stand on which are mounted a non-contact torque meter and a motor.

WEIGHT: 65 lbs (29 kg)

DIMENSIONS: 12 x 24 x 17 inches (305 x 610 x 432 mm)

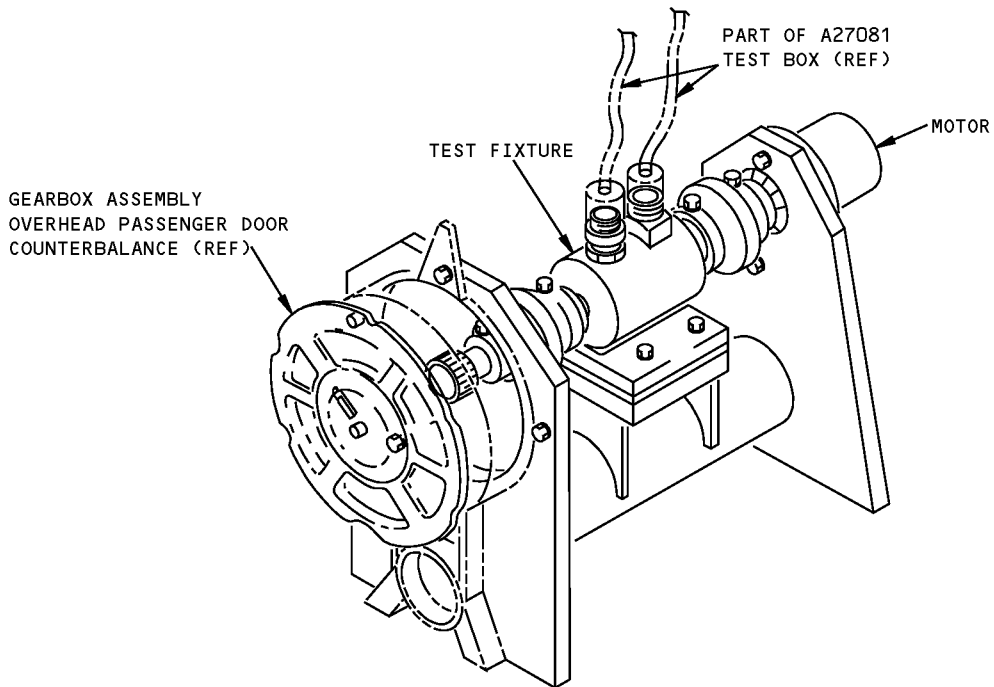

Overhead Passenger Door Counterbalance Gearbox Test Fixture
Figure 1

ILLUSTRATED TOOL AND EQUIPMENT MANUAL

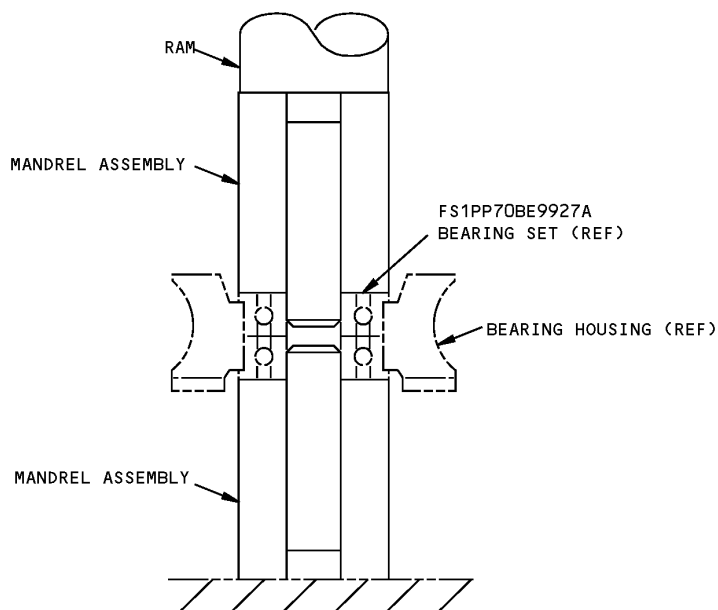
PART NUMBER: A52020-1**NAME:** MANDREL EQUIPMENT - BEARING INSTALLATION**AIRPLANE MAINTENANCE:** NO**COMPONENT MAINTENANCE:** YES**USAGE & DESCRIPTION:** This tool is used to install FS1PP70BE9927A bearing set. Refer to CMM 52-11-06 and CMM 52-11-22 for further usage instructions. This tool consists of two mandrel assemblies and a box assembly.**WEIGHT:** 1 lb (0.5 kg)**DIMENSIONS:** 2 x 2 x 3 inches (51 x 51 x 76 mm)**Bearing Installation Mandrel Equipment****Figure 1**

ILLUSTRATED TOOL AND EQUIPMENT MANUAL

PART NUMBER: A52022-1

NAME: CANOPY - FORWARD ENTRY DOOR

AIRPLANE MAINTENANCE: YES

COMPONENT MAINTENANCE: NO

USAGE & DESCRIPTION: The A52022-1 canopy is used on 767-200, -200ER, -300 and -300ER airplanes. The A52022 canopy is installed at the forward passenger/service door in order to protect the airplane's interior from rain during maintenance operations. The canopy is an aluminum weldment with an attached nylon cover.

WEIGHT: 15 lbs (7 (kg)

DIMENSIONS: 32 x 44 x 48 inches (813 x 1118 x 1219 mm)

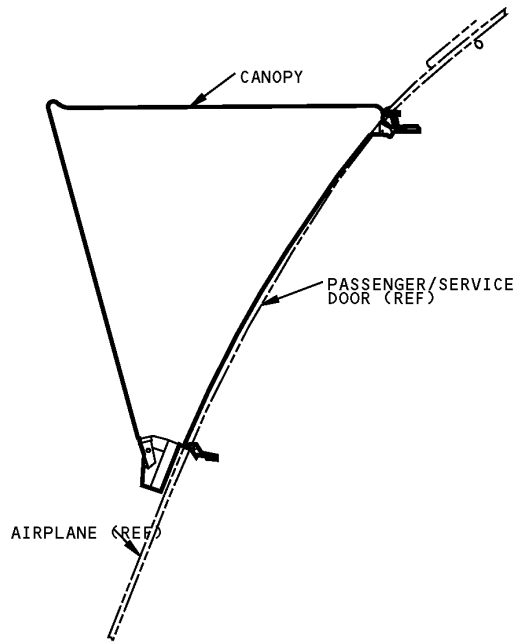

**Forward Entry Door Canopy
Figure 1**

ILLUSTRATED TOOL AND EQUIPMENT MANUAL

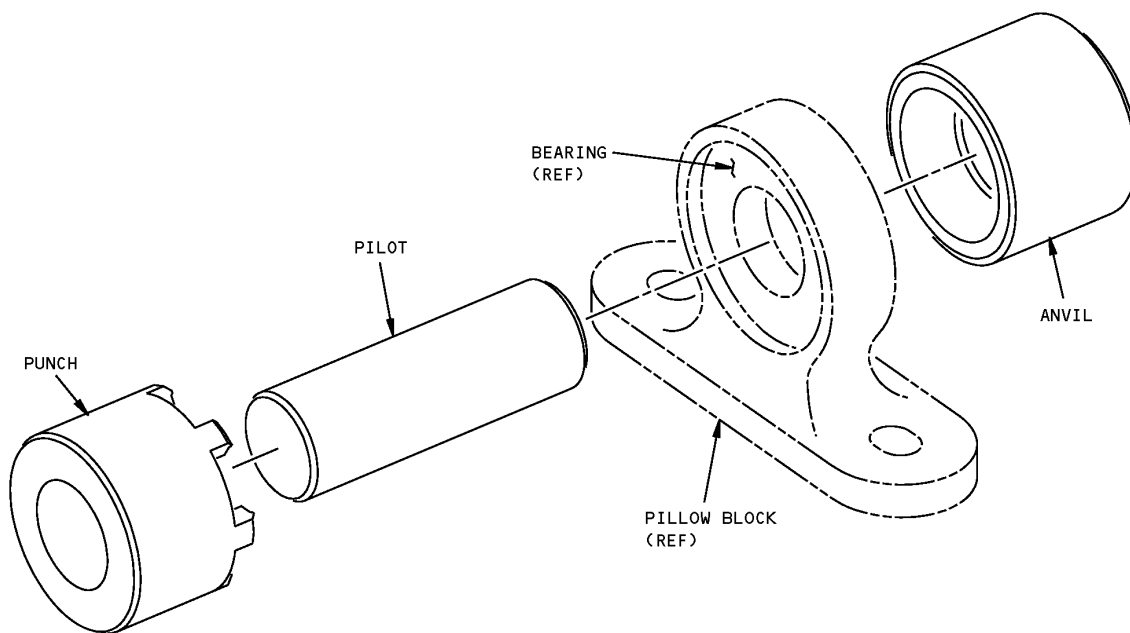
PART NUMBER: A52030-1**NAME:** STAKING EQUIPMENT - GIRT BAR BEARING**AIRPLANE MAINTENANCE:** YES**COMPONENT MAINTENANCE:** NO**USAGE & DESCRIPTION:** This tool is used to install the BACB10FU12 bearing in the 141T6253 pillow block. This tool consists of an anvil, punch, pilot and storage box assembly.**WEIGHT:** 1 lb (0.5 kg)**DIMENSIONS:** 4 x 5 x 8 inches (102 x 127 x 203 mm))

**Girt Bar Bearing Staking Equipment
Figure 1**

ILLUSTRATED TOOL AND EQUIPMENT MANUAL

PART NUMBER: A52015-1, -3

NAME:	SHAFT SUPPORT - COUNTERBALANCE, OVERHEAD PASSENGER DOOR
AIRPLANE MAINTENANCE:	NO
COMPONENT MAINTENANCE:	YES
USAGE & DESCRIPTION:	This tool is used to support the shaft of the overhead passenger door, counterbalance gearbox assembly while (shimming) centering the brake shoes in the V-groove of the gear. Refer to CMM 52-11-71 for further usage instructions. This tool consists of a support shaft.
WEIGHT:	1 lb (0.5 kg)
DIMENSIONS:	1 x 2 x 11 inches (25 x 51 x 279 mm)
NOTE:	A52015-3 replaces A52015-1.

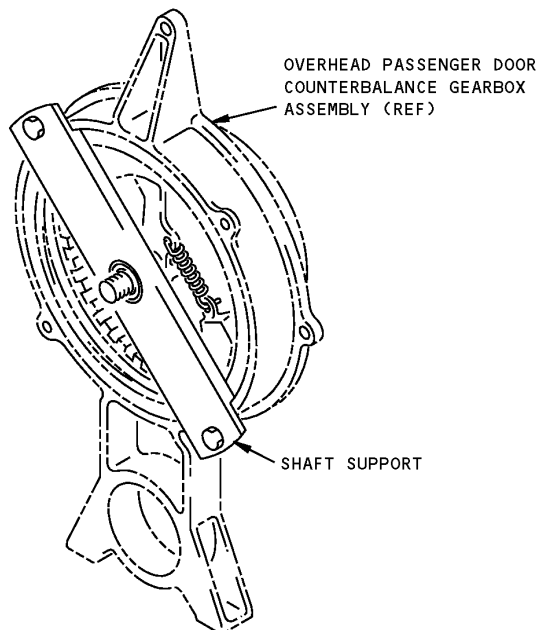

**Overhead Passenger Counterbalance Doorshaft Support
Figure 1**



767

ILLUSTRATED TOOL AND EQUIPMENT MANUAL

PART NUMBER: A52027-1

NAME: SAFETY BARRIER - AFT EMERGENCY EXIT

AIRPLANE MAINTENANCE: YES

COMPONENT MAINTENANCE: NO

USAGE & DESCRIPTION: The A52027-1 safety barrier has a limited effectivity. A52027-1 is used on 767-300 and -300ER airplanes that are equipped with aft type 1 emergency exit doors. A52027 is used to provide a personnel safely barrier across the aft emergency exit doors. Refer to Maintenance Manual 52-22-01 for complete usage instructions. A52027-1 consists of an A52027-2 barrier assembly contained in a storage box.

WEIGHT: 8 lbs (4 kg)

DIMENSIONS: 6 x 6 x 27 inches (152 x 152 x 686 mm)

**767
ILLUSTRATED TOOL AND EQUIPMENT MANUAL**

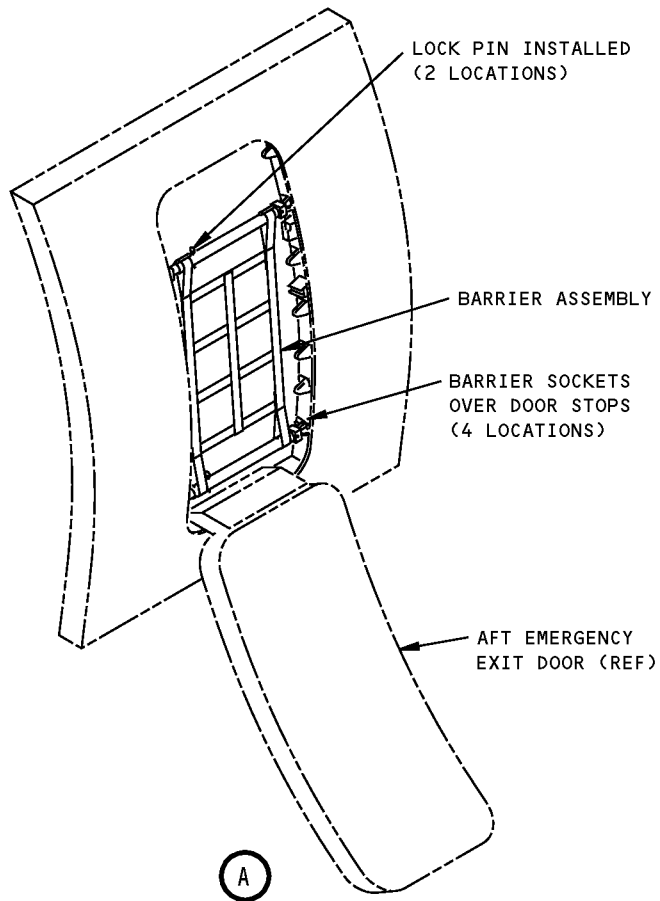
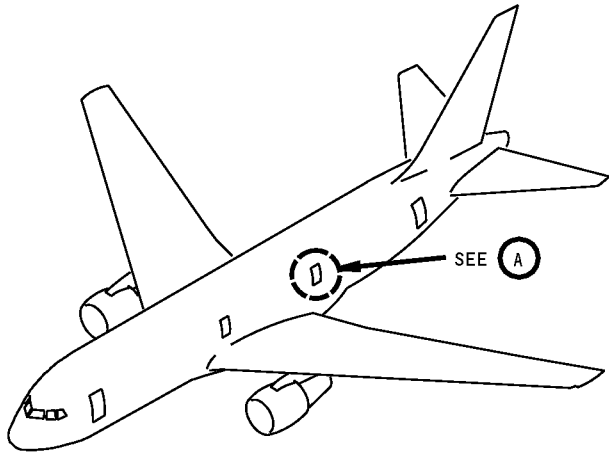

**Aft Emergency Exit Safety Barrier
Figure 1**



767

ILLUSTRATED TOOL AND EQUIPMENT MANUAL

PART NUMBER: A52029-1

NAME: GAGE - GIRT BAR, CARRIER DRIVE

AIRPLANE MAINTENANCE: YES

COMPONENT MAINTENANCE: NO

USAGE & DESCRIPTION: The A52029-1 girt bar carrier drive gage is used on all 767 airplanes. This tool is used to measure the entry/service door girt bar carrier drive jaw angle for the adjustment of the mode select mechanism. Refer to AMM 52-11-00 and current A52029 drawing for further instructions. This tool consists of a -2 gage assembly and a storage box assembly.

WEIGHT: 2 lbs (0.9 kg)

DIMENSIONS: 1 x 5 x 25 inches (25 x 127 x 635 mm)

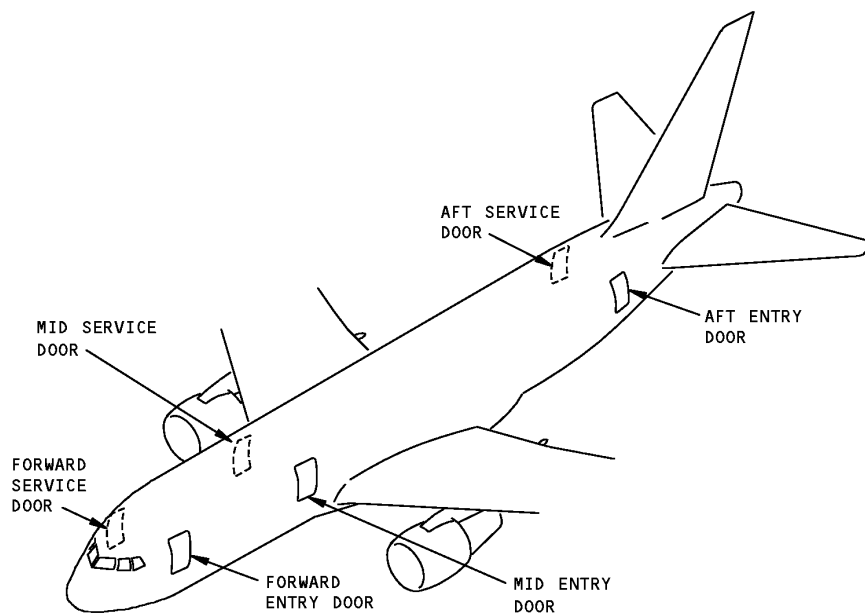

**Entry/Service Door Locations
Figure 1**

ILLUSTRATED TOOL AND EQUIPMENT MANUAL

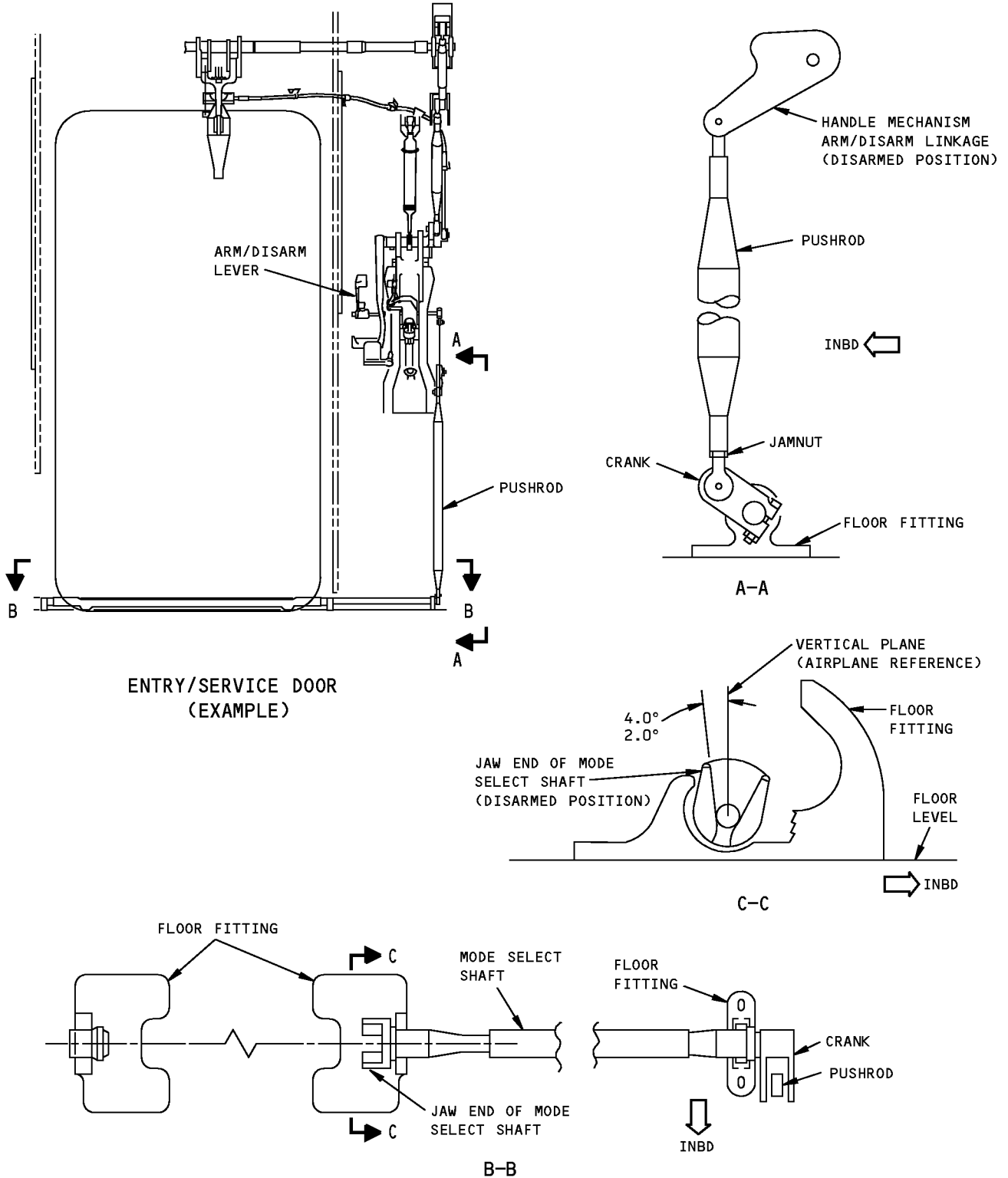

**ENTRY/SERVICE DOOR
(EXAMPLE)**

**Entry/Service Door Mode Select Mechanism
Figure 2**

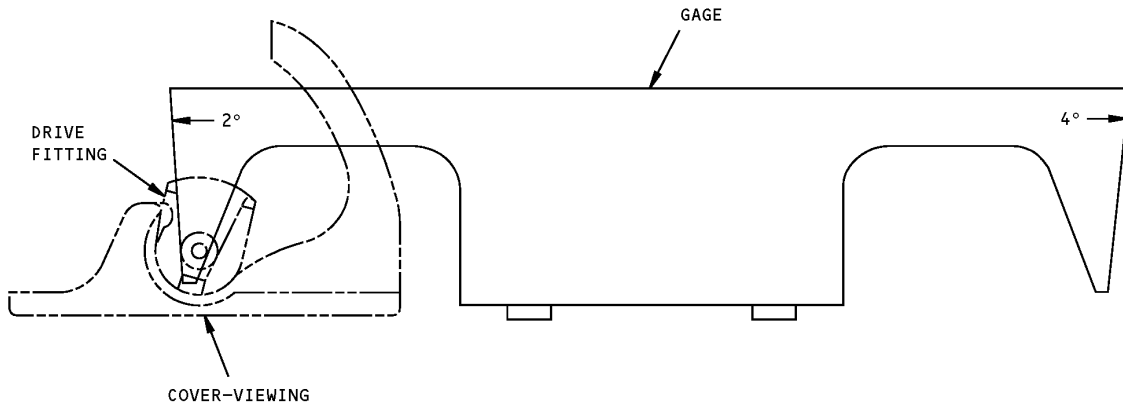

**Carrier Drive Girt Bar Gage
Figure 3**

ILLUSTRATED TOOL AND EQUIPMENT MANUAL

PART NUMBER: A52005-1

NAME: SAFETY BARRIER - CARGO DOOR, FORWARD/AFT

AIRPLANE MAINTENANCE: YES

COMPONENT MAINTENANCE: NO

USAGE & DESCRIPTION: The A52005-1 safety barrier is used on 767-200, -200ER, -300, -300ER and -400ER airplanes. A52005 is not used on the 767 freighter. A52005 is used to prevent injury to personnel when the forward and/or aft small cargo doors are open or removed and the loading or unloading equipment is not in use. Refer to AMM 25-33-02, AMM 25-53-01, AMM 25-53-01, AMM 25-53-03, AMM 25-53-04, AMM 25-53-08, AMM 25-53-09, AMM 25-53-11, AMM 25-53-12, AMM 25-53-13, AMM 25-53-14, AMM 25-53-15, AMM 25-53-26, AMM 25-53-27, AMM 52-35-00, AMM 52-35-01, AMM 52-35-02 and AMM 52-35-03 for complete usage instructions. A52005-1 consists of an A52005-2 frame assembly, an A52005-10 webbing assembly, two A52005-14 rubber pads and connecting hardware.

WEIGHT: 45 lbs (20 kg)

DIMENSIONS: 5 x 69 x 80 inches (127 x 1753 x 2032 mm)

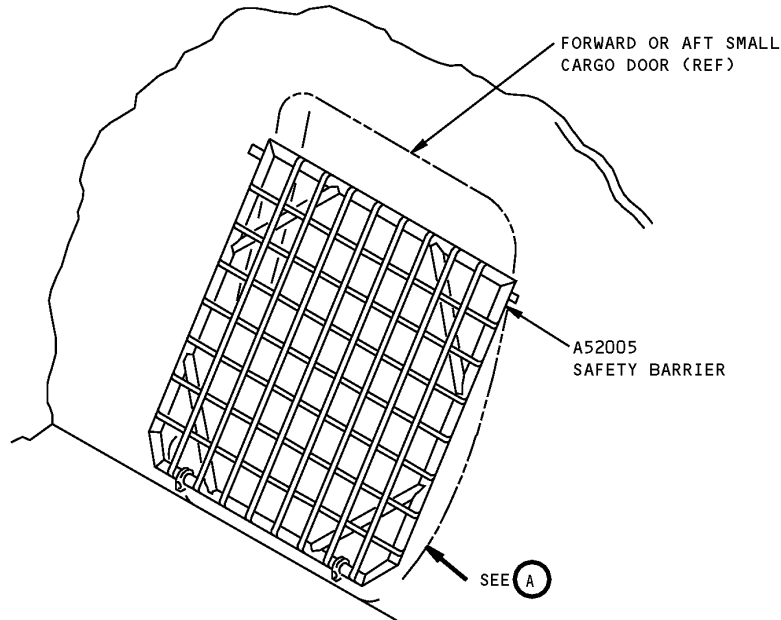

**Forward/Aft Cargo Door Safety Barrier
Figure 1 (Sheet 1 of 2)**

ILLUSTRATED TOOL AND EQUIPMENT MANUAL

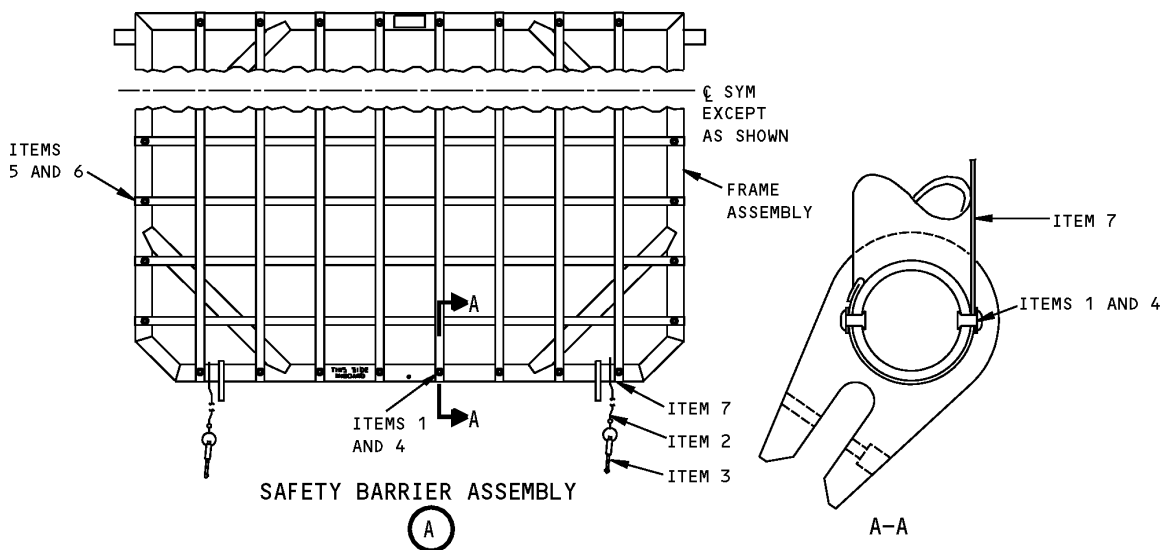

Forward/Aft Cargo Door Safety Barrier
Figure 1 (Sheet 2 of 2)

REPAIRABLE/REPLACEABLE PARTS			
ITEM NO.	PART NO.	NOMENCLATURE	VENDOR CODE
1	NAS1398D6-6	RIVET	
2	CL-22-KA-15.0LR	CABLE	V99862
3	NAS1334A6S21D	BALL LOCK PIN	
4	AN960D9	WASHER	
5	A52005-10	WEBBING ASSEMBLY	
6	A52005-4	WEBBING	
7	A52005-5	WEBBING	



767

ILLUSTRATED TOOL AND EQUIPMENT MANUAL

PART NUMBER: A52004-41, -42, -43

NAME: SLING EQUIPMENT - DOOR HANDLING

AIRPLANE MAINTENANCE: YES

COMPONENT MAINTENANCE: NO

USAGE & DESCRIPTION: The A52004-41, -42 and -43 sling equipment is used on all 767 airplanes. The A52004-41 "fitting equipment" is used with the A52004-43 "sling equipment" to remove or install the forward or aft small cargo door. The A52004-42 "fitting equipment - large cargo door" is used with the A52004-43 "sling equipment" to remove or install the optional forward large cargo door. The A52004-42 "fitting equipment - large cargo door" is used with the A52004-43 "sling equipment" to remove or install the forward or aft freighter cargo door. Refer to AMM 52-33-01, AMM 52-33-05, AMM 52-34-00, AMM 52-34-01, AMM 52-34-02, AMM 52-35-00, AMM 52-35-01, AMM 52-35-02, AMM 52-37-01, AMM 52-37-05 and current A52004 drawing for additional usage instructions.

A52004-41 consists of two A52004-48 forward/aft doors fitting assemblies contained in a storage box.

A52004-42 consists of two A52004-49 large door fitting assemblies contained in a storage box.

A52004-43 consists of an A52004-50 sling assembly contained in a storage box.

WEIGHT: A52004-41 - 5 lbs (2.2 kg)
A52004-42 - 5 lbs (2.2 kg)
A52004-43 - 30 lbs (14 kg)

DIMENSIONS: A52004-41 - 6 x 6 x 8 inches (152 x 152 x 203 mm)
A52004-42 - 6 x 6 x 8 inches (152 x 152 x 203 mm)
A52004-43 - 10 x 10 x 60 inches (254 x 254 x 1524 mm)

NOTE: A52004-41, -42 and -43 supersede A52004-40, -10 and -17 respectively.
A52004-41 and -43 supersede A52004-1.

ILLUSTRATED TOOL AND EQUIPMENT MANUAL

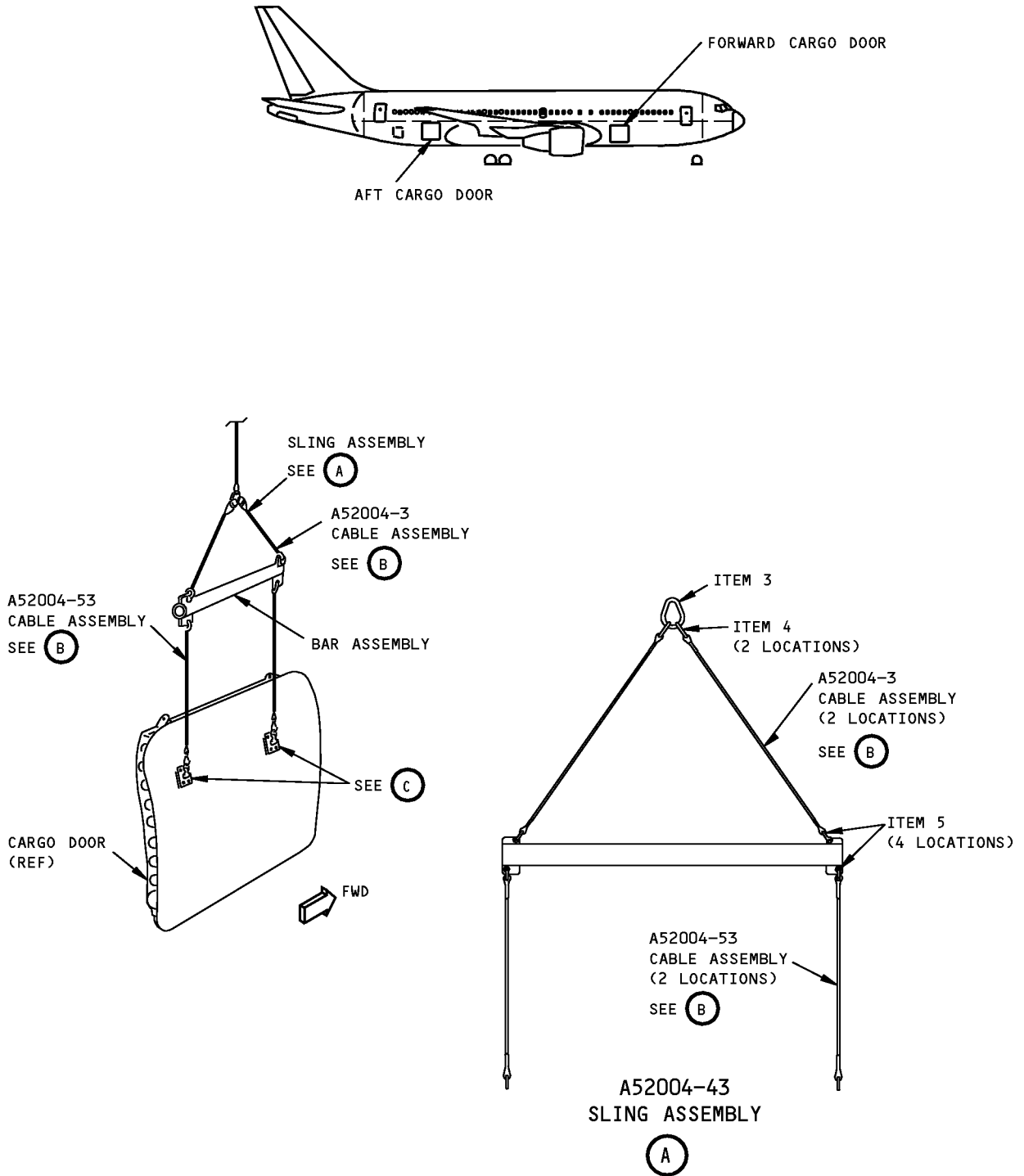

Door Handling Sling Equipment
Figure 1 (Sheet 1 of 2)

ILLUSTRATED TOOL AND EQUIPMENT MANUAL

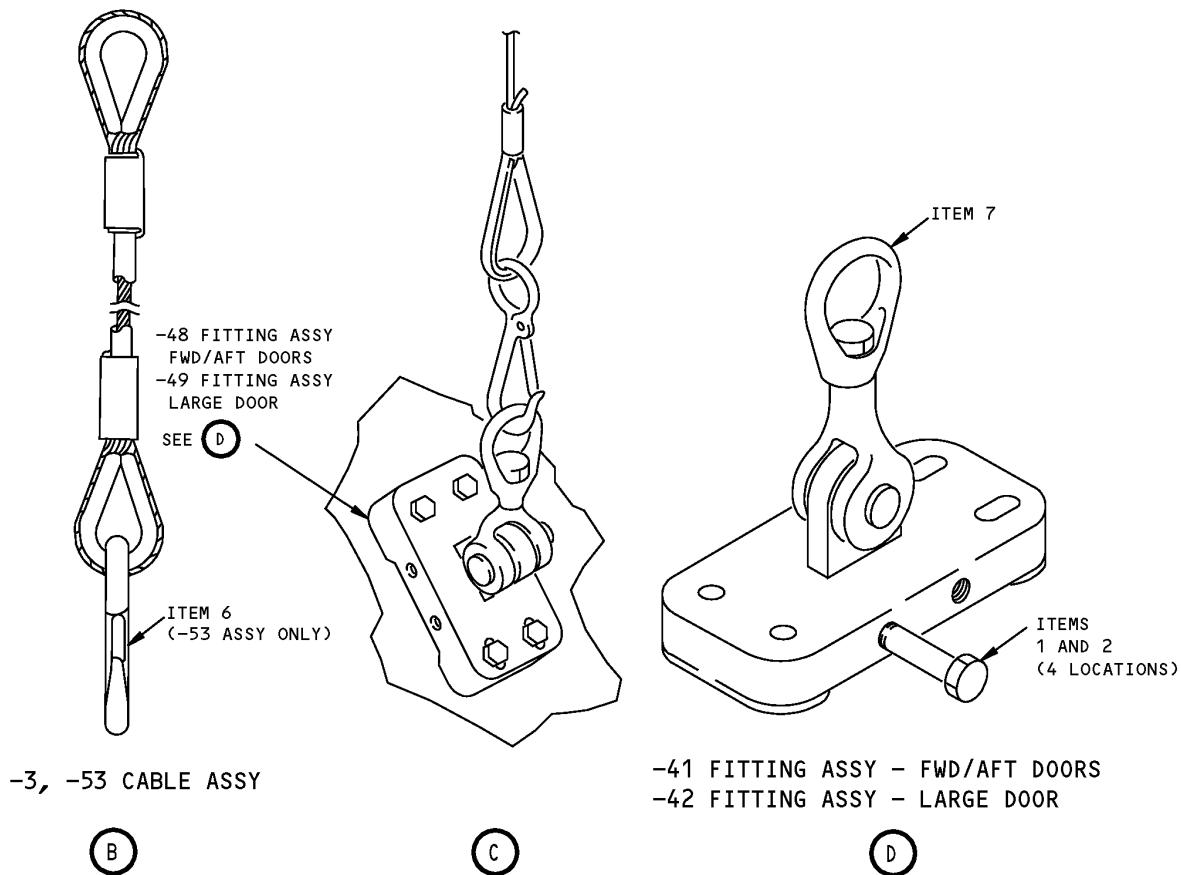

Door Handling Sling Equipment
Figure 1 (Sheet 2 of 2)

REPAIRABLE/REPLACEABLE PARTS			
ITEM NO.	PARTS NO.	NOMENCLATURE	VENDOR CODE
1	NAS1304-17	BOLT	
2	NAS1304-11	BOLT	
3	G-341-5/8	SLING LINK	V75535
4	G-336-1/2	CONNECTING LINK	V75535
5	G-213-5/16	SHACKLE	V75535
6	G-3315-9/16	SNAP HOOK	V75535
7	G-403-5/16	JAW END	V75535
8	F70308-2	PROOF LOAD TAG	



767

ILLUSTRATED TOOL AND EQUIPMENT MANUAL

PART NUMBER: A52006-1

NAME: REPLACEMENT EQUIPMENT - BULK CARGO DOOR

AIRPLANE MAINTENANCE: YES

COMPONENT MAINTENANCE: NO

USAGE & DESCRIPTION: The A52006-1 replacement equipment is used on all 767 airplanes. A52006 is used to remove and install the bulk cargo door. A52006 consists of two major components which are used in conjunction with a customer-furnished fishpole hoist. The A52006-2 beam assembly clamps onto the main deck floor beam, provides for lateral cargo door maneuverability and mounts the fishpole hoist. The A52006-3 carrier assembly locks onto the bulk cargo door and with the fishpole hoist, raises or lowers the door. Refer to AMM 52-36-01 for complete usage instructions. A52006-1 consists of an A52006-2 beam assembly and an A52006-3 carrier assembly both contained in a storage box.

WEIGHT: 54 lbs (15 kg)

DIMENSIONS: 5 x 18 x 92 inches (127 x 457 x 2337 mm)

767
ILLUSTRATED TOOL AND EQUIPMENT MANUAL

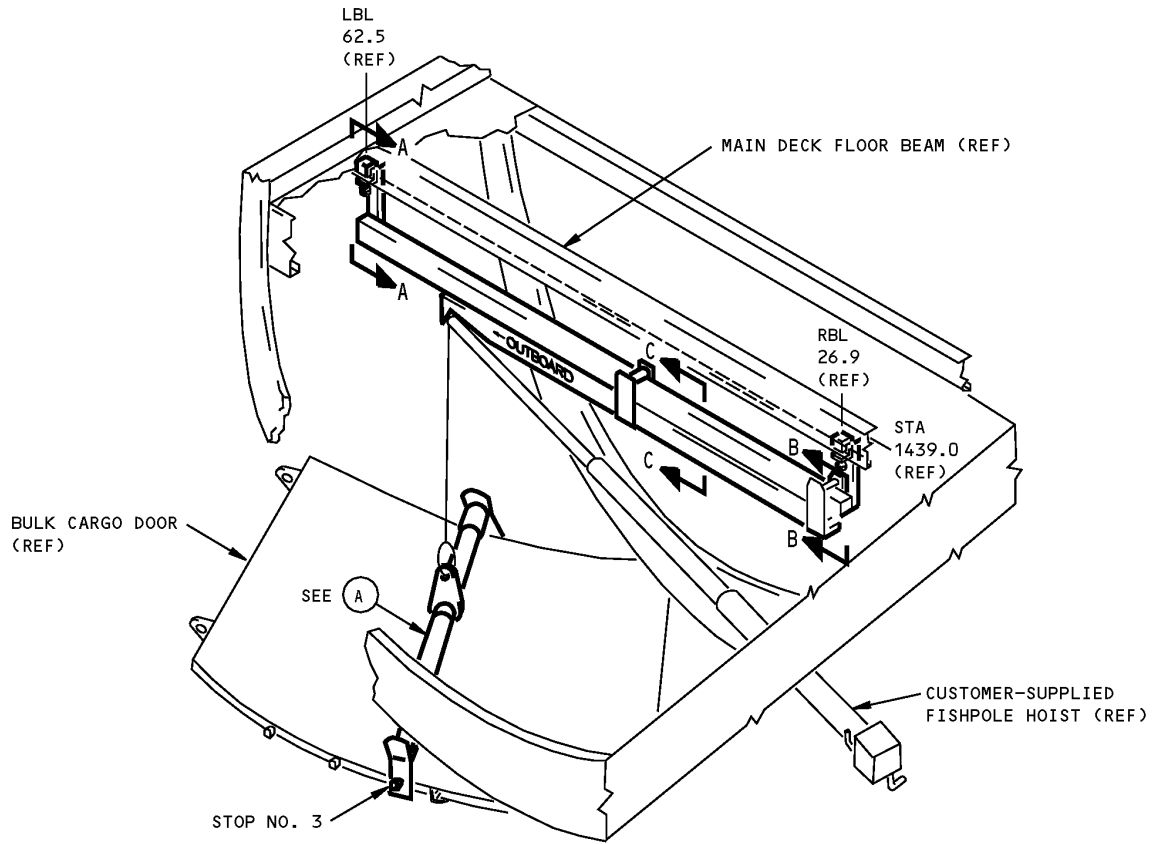

Bulk Cargo Door Replacement Equipment
Figure 1 (Sheet 1 of 2)

ILLUSTRATED TOOL AND EQUIPMENT MANUAL

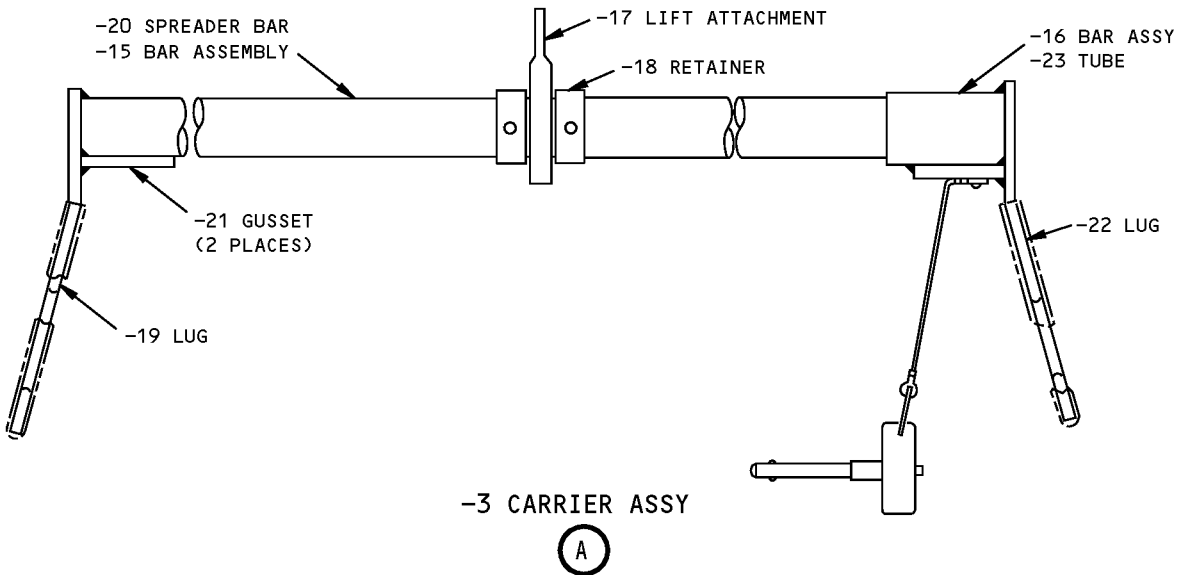
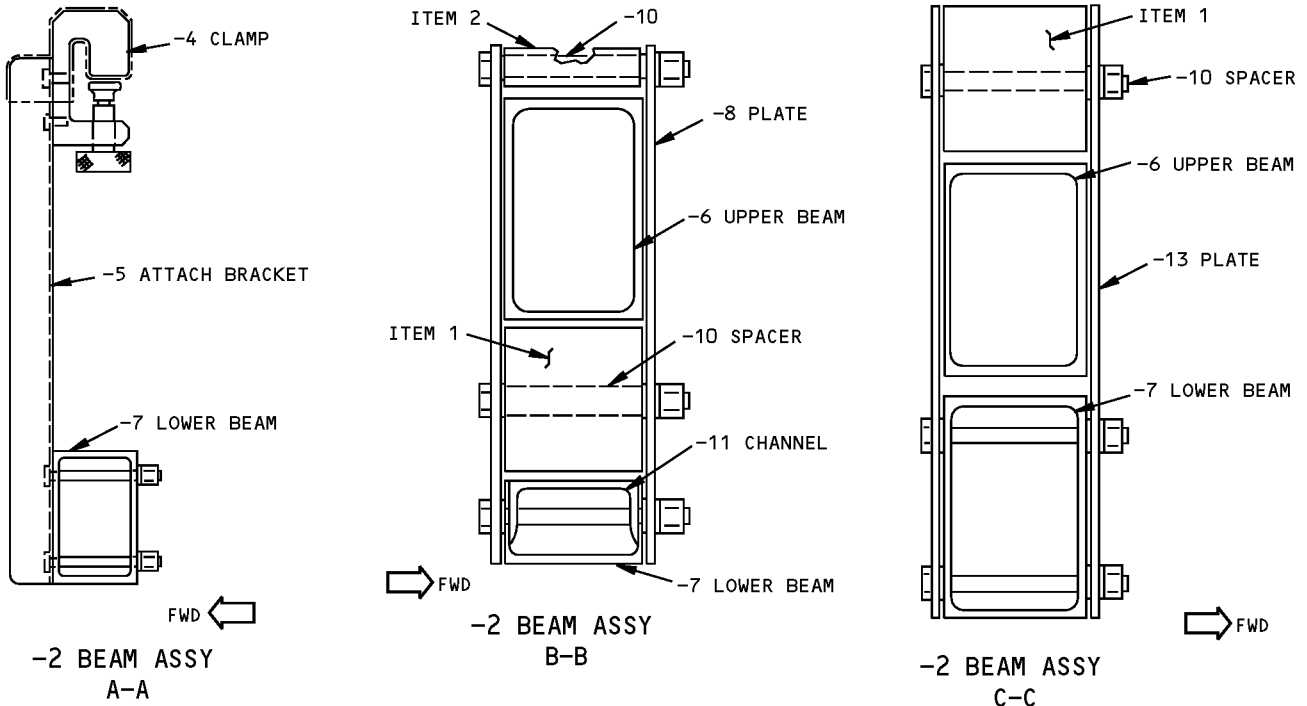

**Bulk Cargo Door Replacement Equipment
Figure 1 (Sheet 2 of 2)**



767

ILLUSTRATED TOOL AND EQUIPMENT MANUAL

REPAIRABLE/REPLACEABLE PARTS			
ITEM NO.	PART NO.	NOMENCLATURE	VENDOR CODE
1	A52006-9	ROLLER	
2	A52006-12	ROLLER	
3	F70308-2	PROOF LOAD TAG	

ILLUSTRATED TOOL AND EQUIPMENT MANUAL

PART NUMBER: A52007-1

NAME: SAFETY BARRIER - FORWARD LARGE CARGO DOOR

AIRPLANE MAINTENANCE: YES

COMPONENT MAINTENANCE: NO

USAGE & DESCRIPTION: The A52007-1 safety barrier is used on all 767 airplanes. A52007 is a webbing and frame assembly which is used when the door is open or removed to prevent personnel from falling from the large cargo door. Refer to AMM 25-53-00, AMM 25-53-02, AMM 25-53-03, AMM 25-53-04, AMM 25-53-09, AMM 25-53-11, AMM 25-53-12, AMM 25-53-13, AMM 25-53-14, AMM 25-53-15, AMM 25-53-16, AMM 25-53-21, AMM 25-53-22, AMM 25-53-23, AMM 25-53-24, AMM 25-53-25, AMM 25-53-26, AMM 25-53-27, AMM 52-33-00 and AMM 52-33-01 for complete usage instructions. A52007-1 consists of an aluminum frame, nylon webbing and connected with various hardware.

WEIGHT: 90 lbs (41 kg)

DIMENSIONS: 8 x 52 x 126 inches (203 x 1321 x 3200 mm)

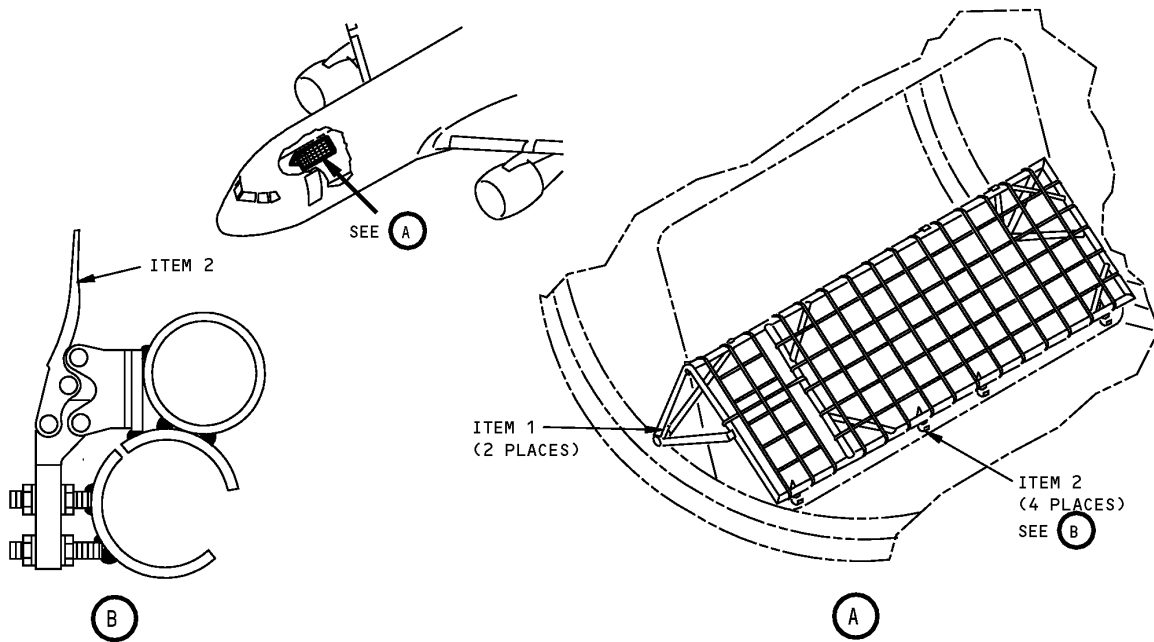

**Forward Large Cargo Door Safety Barrier
Figure 1**



767

ILLUSTRATED TOOL AND EQUIPMENT MANUAL

REPAIRABLE/REPLACEABLE PARTS			
ITEM NO.	PART NO.	NOMENCLATURE	VENDOR CODE
1	NAS1338C3C30D	BALL LOCK PIN	
2	CL-450-HTC	TOGGLE CLAMP	V99862

ILLUSTRATED TOOL AND EQUIPMENT MANUAL

PART NUMBER: A52009-1, -22

NAME: TEST FIXTURE - BUNGEE SPRING, CARGO DOOR

AIRPLANE MAINTENANCE: NO

COMPONENT MAINTENANCE: YES

USAGE & DESCRIPTION: The A52009-1 or -22 test fixture is used on all 767 airplanes. A52009 is used to perform a functional test on the cargo door bungee spring assembly. Refer to CMM 52-34-05 for complete usage instructions. Each of A52009-1 and A52009-22 test fixtures consists of an A52009-2 measuring assembly, an A52009-3 jack screw assembly, an A52009-7 base and connecting hardware. The A52009-22 also includes a CL-22-KA-8.0-LR cable assembly to secure usage placard to the test fixture.

WEIGHT: 30 lbs (14 kg)

DIMENSIONS: 6 x 10 x 45 inches (152 x 254 x 1143 mm)

NOTE: A52009-22 replaces A52009-1 for future procurement.

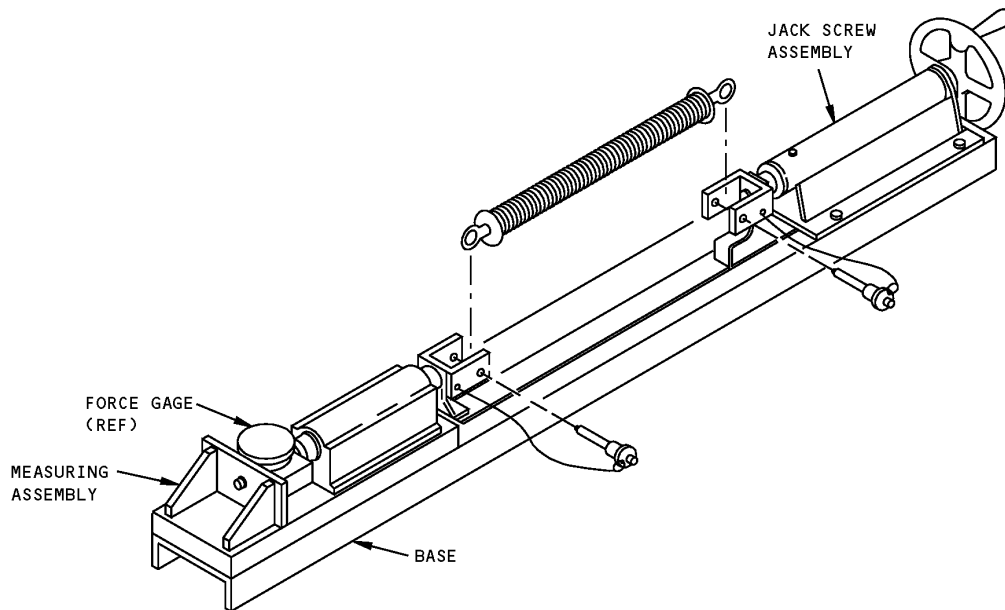

**Cargo Door Bungee Spring Test Fixture
Figure 1**



767

ILLUSTRATED TOOL AND EQUIPMENT MANUAL

PART NUMBER: A52010-50, -51

NAME: CLAMP EQUIPMENT - SPRING INSTALLATION/REMOVAL, BULK CARGO DOOR

AIRPLANE MAINTENANCE: YES

COMPONENT MAINTENANCE: YES

USAGE & DESCRIPTION: The A52010-50 or -51 clamp equipment is used on all 767 airplanes. A52010 is used to remove/install the spring in the spring tube assembly of the bulk cargo door balance system. The A52010-50 clamp equipment is used only on 767 airplanes. The A52010-51 clamp equipment is used on 757 and 767 airplanes. Refer to AMM 52-36-02, AMM 52-36-05 and CMM 52-36-25 for complete usage instructions. A52010-50 and -51 consist of:

A52010-50		
QUANTITY	NOMENCLATURE	PART NUMBER
1	CLAMP ASSEMBLY	A52010-31
1	CLAMP ASSEMBLY	A52010-52
1	STORAGE BOX	

A52010-51		
QUANTITY	NOMENCLATURE	PART NUMBER
1	CLAMP ASSEMBLY	A52010-26
1	CLAMP ASSEMBLY	A52010-31
1	CLAMP ASSEMBLY	A52010-52
1	STORAGE BOX	

WEIGHT: A52010-50 - 15 lbs (7 kg)
A52010-51 - 16 lbs (7 kg)

DIMENSIONS: A52010-50 - 7 x 10 x 41 inches (178 x 254 x 1041 mm)
A52010-51 - 7 x 10 x 45 inches (178 x 254 x 1143 mm)

NOTE: A52010-50 and -51 supersedes A52010-14 and -15 respectively.

767
ILLUSTRATED TOOL AND EQUIPMENT MANUAL

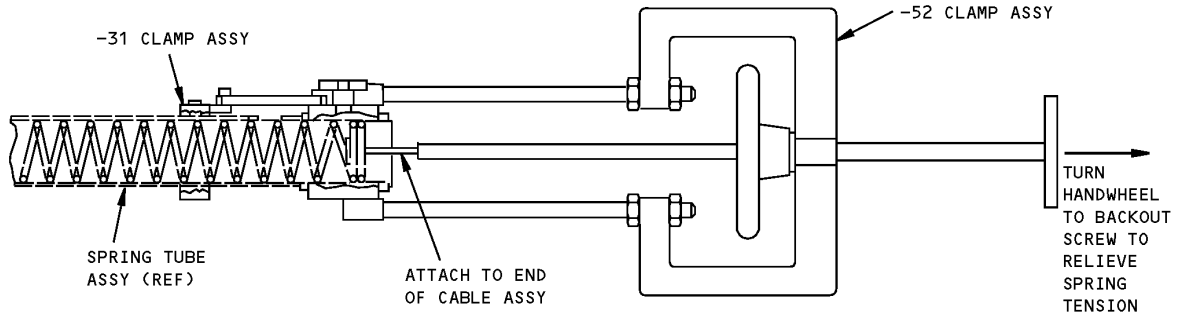

Bulk Cargo Door Spring Installation/Removal Clamp Equipment
Figure 1



767

ILLUSTRATED TOOL AND EQUIPMENT MANUAL

PART NUMBER: A52012-1, -6 WAS DELETED

ILLUSTRATED TOOL AND EQUIPMENT MANUAL

PART NUMBER: A52014-1

NAME: ADJUSTMENT SET - MAIN LATCH PIN, LARGE CARGO DOORS

AIRPLANE MAINTENANCE: YES

COMPONENT MAINTENANCE: NO

USAGE & DESCRIPTION: The A52014-1 adjustment set is used on all 767 airplanes with large forward cargo doors and 767-300 freighters with large forward and aft cargo doors. A52014 measures latch cam/latch pin fitting gaps to aid in adjusting latch pins on the large cargo door. Refer to AMM 52-33-00 and AMM 52-37-00 for complete usage instructions. A52014-1 consists of six A52014-2 adjustment assemblies and six A52014-3 adjustment assemblies contained in a storage box.

WEIGHT: 25 lbs (11 kg)

DIMENSIONS: 3 x 10 x 18 inches (76 x 254 x 457 mm)

NOTE: A52014 supersedes A52012.

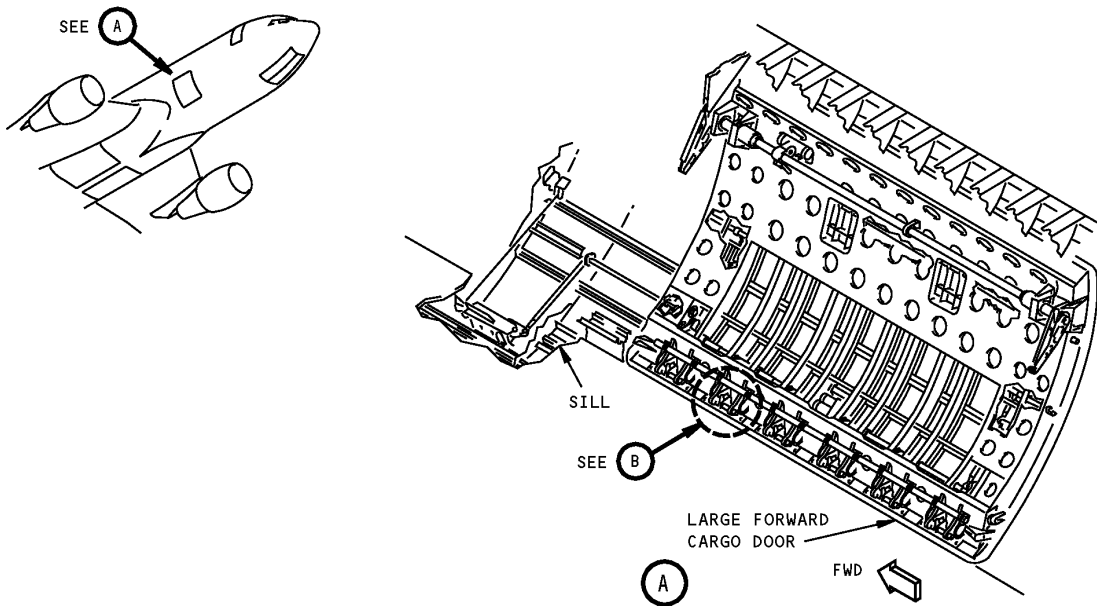

**Large Cargo Doors Main Latch Pin Adjustment Set
Figure 1 (Sheet 1 of 2)**

767
ILLUSTRATED TOOL AND EQUIPMENT MANUAL

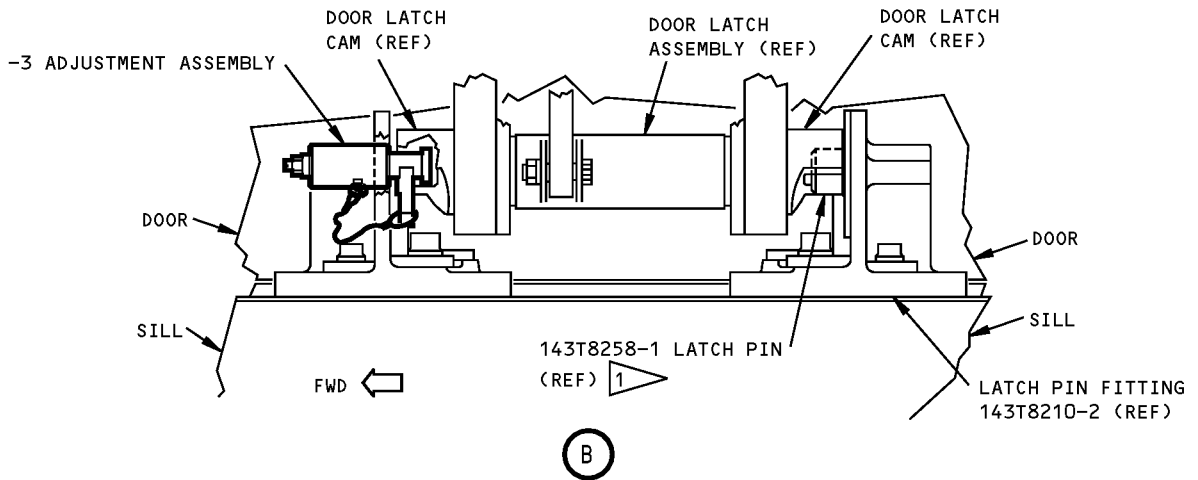

1 USE -2 ADJUSTMENT ASSEMBLY

Large Cargo Doors Main Latch Pin Adjustment Set
Figure 1 (Sheet 2 of 2)



767

ILLUSTRATED TOOL AND EQUIPMENT MANUAL

PART NUMBER: A52016-1

NAME: RIGGING ADJUSTMENT EQUIPMENT - FORWARD AND AFT CARGO DOORS

AIRPLANE MAINTENANCE: YES

COMPONENT MAINTENANCE: NO

USAGE & DESCRIPTION: The A52016-1 rigging adjustment equipment is used on all 767 airplanes. A52016 is used for rigging adjustment of the forward and aft cargo doors. Refer to AMM 52-35-00 and AMM 52-35-01 for complete usage instructions. A52016-1 consists of four A52016-2 wedges and one each of A52016-3, -5, -6, -7, -8, -9, -10, -11, -18, -19, -20, -24, -25, -26, -37, -40, -41, -42, -55 gage assemblies, all contained in a storage box.

WEIGHT: 15 lbs (7 kg)

DIMENSIONS: 3 x 10 x 27 inches (76 x 254 x 686 mm)

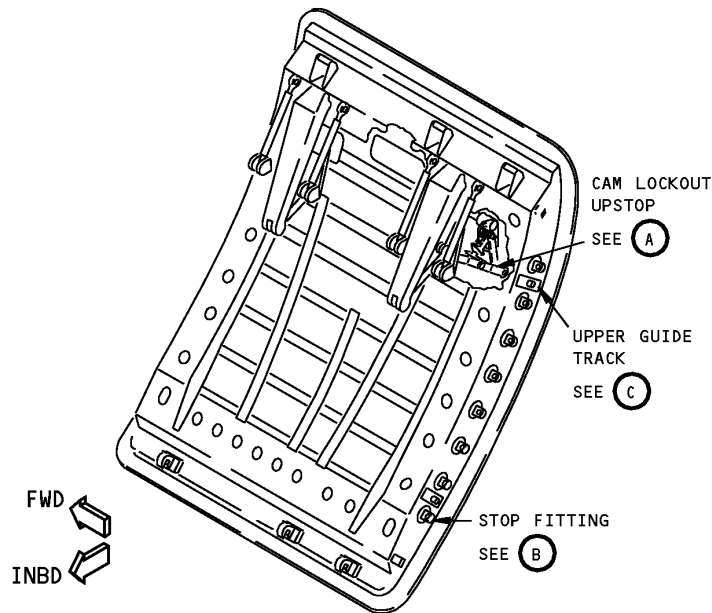

L79921 S0000190085_V2

**Forward And Aft Cargo Doors Rigging Adjustment Equipment
Figure 1 (Sheet 1 of 2)**

ILLUSTRATED TOOL AND EQUIPMENT MANUAL

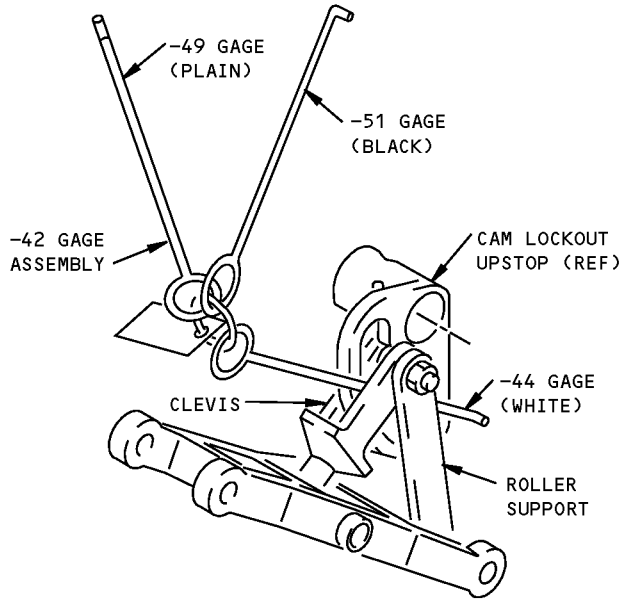

CAM LOCKOUT UPSTOP

(A)

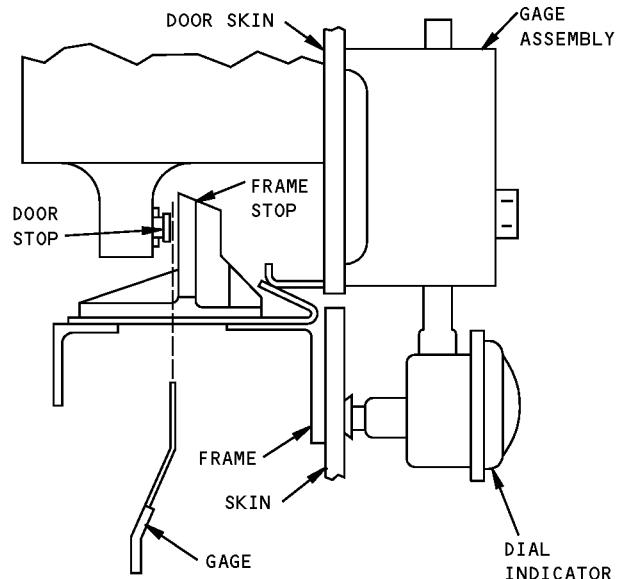

STOP FITTING - PLAN VIEW

(B)

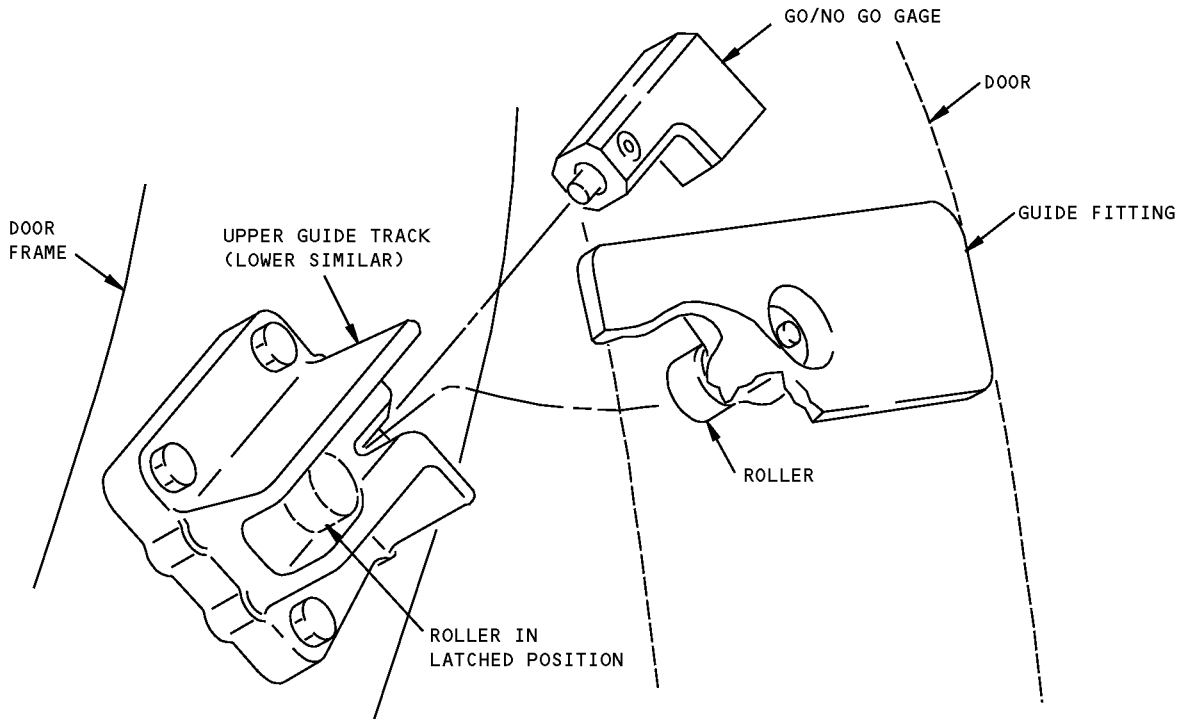

FORWARD UPPER GUIDE TRACK SHOWN

(C)

**Forward And Aft Cargo Doors Rigging Adjustment Equipment
Figure 1 (Sheet 2 of 2)**



767
ILLUSTRATED TOOL AND EQUIPMENT MANUAL

PART NUMBER: A52019-1

NAME: DRIVER SET - HINGE PIN, LARGE CARGO DOOR

AIRPLANE MAINTENANCE: YES

COMPONENT MAINTENANCE: NO

USAGE & DESCRIPTION: The A52019-1 driver set is used on all 767 airplanes. A52019 is used for removing the center hinge pins from the large forward cargo door. The different lengths of the A52019-2 thru -5 drivers are used to accommodate the different hinge pin lengths. Refer to AMM 52-33-00 for complete usage instructions. A52019-1 consists of:

A52019-1		
QUANTITY	NOMENCLATURE	PART NUMBER
1	ROD ASSEMBLY	A52019-2
1	ROD ASSEMBLY	A52019-3
1	ROD ASSEMBLY	A52019-4
1	ROD ASSEMBLY	A52019-5
1	STORAGE BOX	

WEIGHT: 4 lbs (1.8 kg)

DIMENSIONS: 1 x 6 x 68 inches (25 x 152 x 1727 mm)



767

ILLUSTRATED TOOL AND EQUIPMENT MANUAL

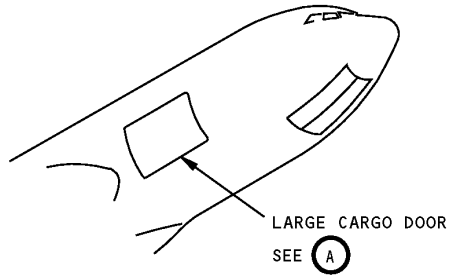

Large Cargo Door Hinge Pin Driver Set
Figure 1 (Sheet 1 of 2)

ILLUSTRATED TOOL AND EQUIPMENT MANUAL

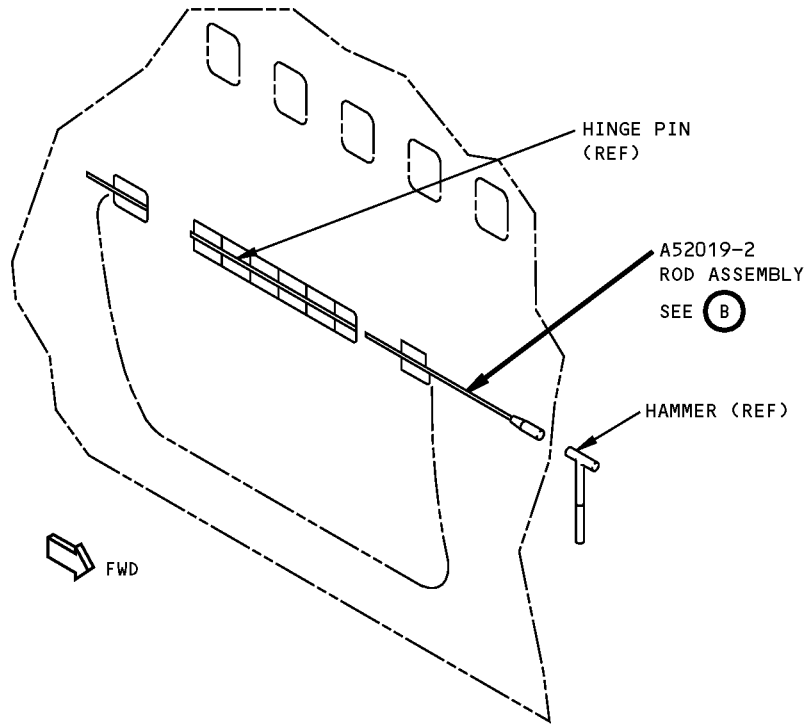

LARGE CARGO DOOR

(A)

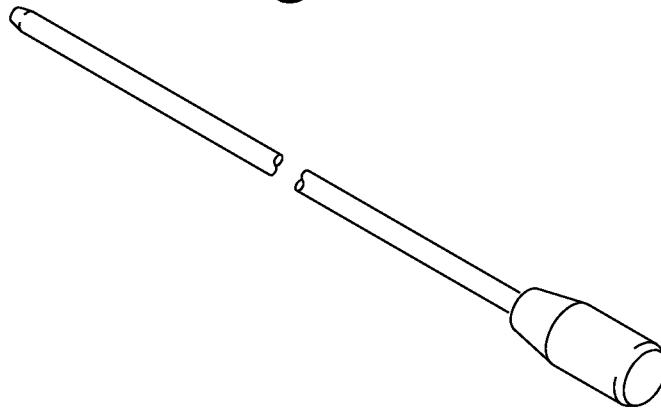

A52019-2 ROD ASSEMBLY SHOWN
A52019-3, -4, -5 SIMILAR

(B)

**Large Cargo Door Hinge Pin Driver Set
Figure 1 (Sheet 2 of 2)**

ILLUSTRATED TOOL AND EQUIPMENT MANUAL

PART NUMBER: A52021-1

NAME: WRENCH - PROXIMITY SENSOR, BULK CARGO DOOR

AIRPLANE MAINTENANCE: YES

COMPONENT MAINTENANCE: NO

USAGE & DESCRIPTION: The A52021-1 wrench is used on all 767 airplanes. A52021 is used to install or remove BACN10JC3 nuts which attach the S283T006-7 sensor in the bulk cargo door. refer to AMM 52-71-00 and AMM 52-71-01 for complete usage instructions. A52021-1 consists of an A52021-2 wrench contained in a storage box.

WEIGHT: 1 lb (0.5 kg)

DIMENSIONS: 3 x 7 x 8 inches (76 x 178 x 203 mm)

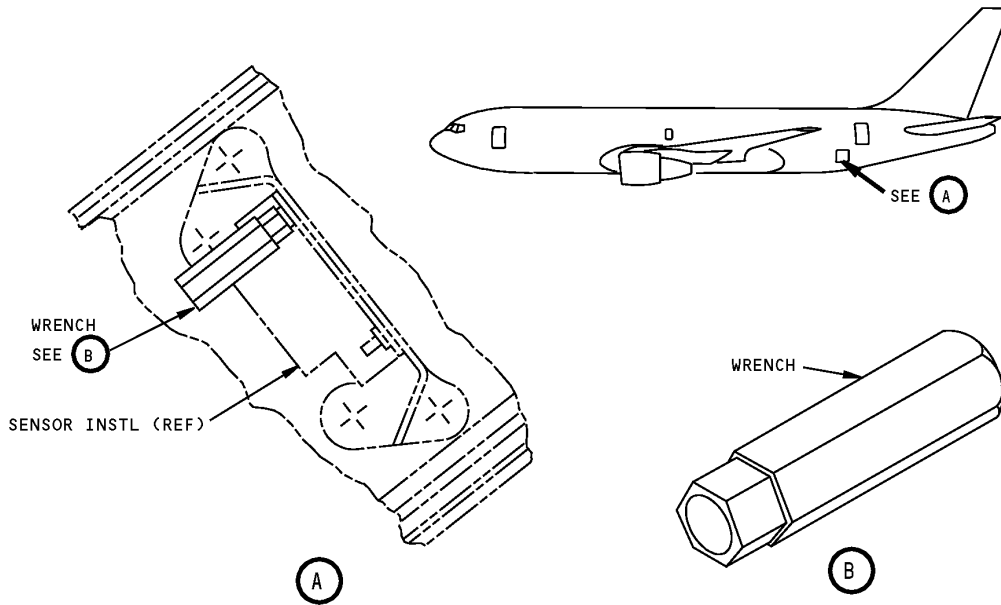

**Bulk Cargo Door Proximity Sensor Wrench
Figure 1**



767

ILLUSTRATED TOOL AND EQUIPMENT MANUAL

PART NUMBER: A52023-1

NAME: BACKLASH CHECK EQUIPMENT - MANUAL DRIVE, LARGE CARGO DOOR

AIRPLANE MAINTENANCE: NO

COMPONENT MAINTENANCE: YES

USAGE & DESCRIPTION: The A52023-1 verification equipment is used on all 767 airplanes. The A52023 backlash check equipment is on the 285T5001-1 large cargo door manual drive gearbox assembly. A52028-1 consists of:

A52028-1		
QUANTITY	NOMENCLATURE	PART NUMBER
1	ARM WELDMENT	A52028-2
1	ARM WELDMENT	A52028-3
1	DIAL INDICATOR	656-517J
1	BOLT	AN4-10A
1	WASHER	AN960-416
1	SELF-LOCKING HEX NUT	MS21044N4
1	SOCKET HEAD CAP SCREW	MS16998-45
1	STORAGE BOX	

WEIGHT: 5 lbs (2.3 kg)

DIMENSIONS: 4 x 6 x 12 inches (102 x 152 x 305 mm)

ILLUSTRATED TOOL AND EQUIPMENT MANUAL

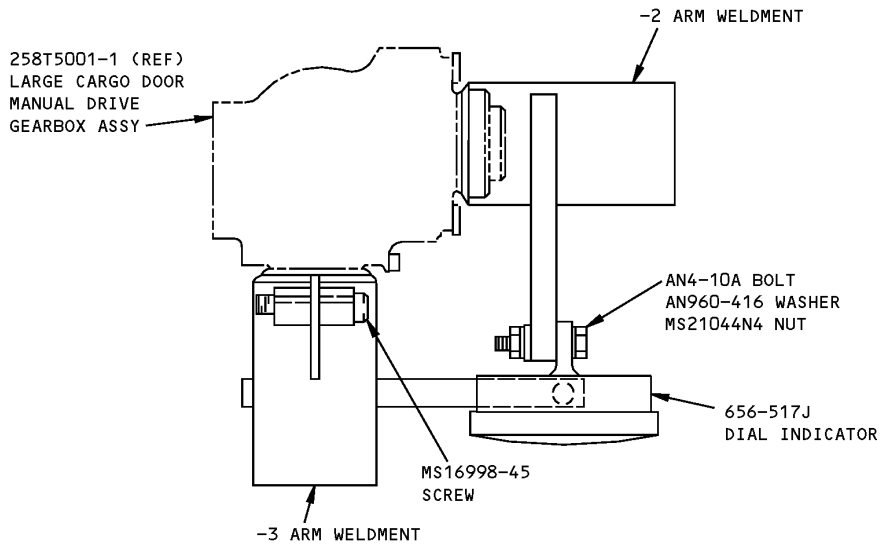

**Large Cargo Door Manual Drive Backlash Check Equipment
Figure 1**

ILLUSTRATED TOOL AND EQUIPMENT MANUAL

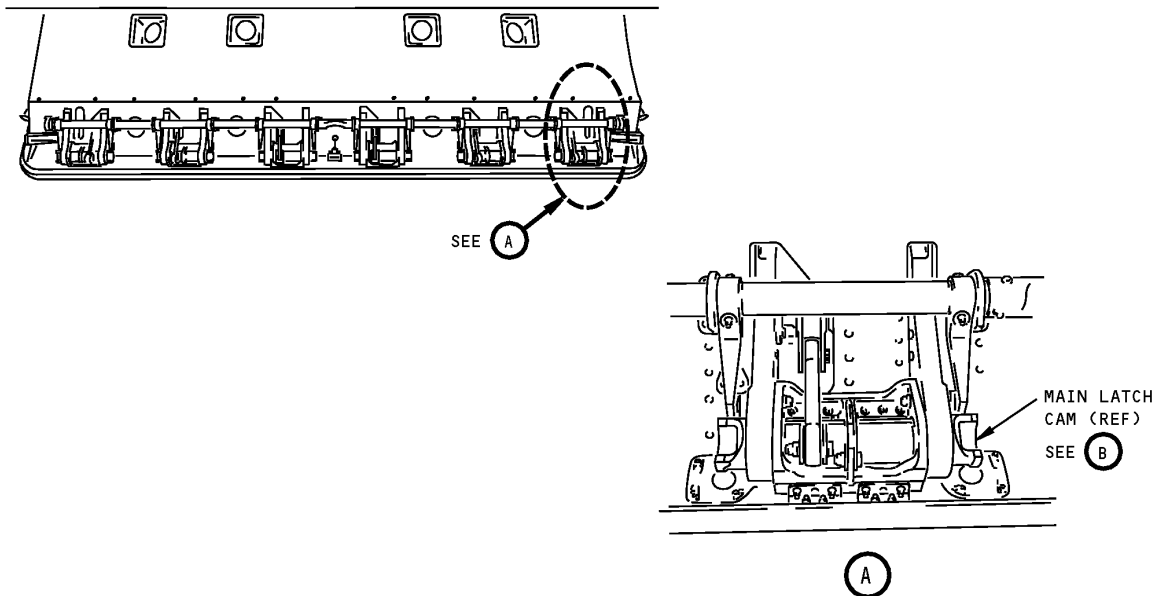
PART NUMBER: A52028-1**NAME:** VERIFICATION EQUIPMENT - MAIN LATCH FITTINGS, LARGE CARGO DOOR**AIRPLANE MAINTENANCE:** YES**COMPONENT MAINTENANCE:** NO**USAGE & DESCRIPTION:** The A52028-1 verification equipment is used on all 767 airplanes. A52028 uses two templates to aid in verifying and restoring the location of the alignment marks on the main latch cam and main latch pin fitting assembly of the large forward cargo door. A52028-1 consist of an A52028-2 templates and an A52028-3 template, both contained in a storage box.**WEIGHT:** 2 lbs (1 kg)**DIMENSIONS:** 1 x 5 x 5 inches (25 x 127 x 127 mm)

**Large Cargo Door Main Latch Fittings Verification Equipment
Figure 1 (Sheet 1 of 3)**

ILLUSTRATED TOOL AND EQUIPMENT MANUAL

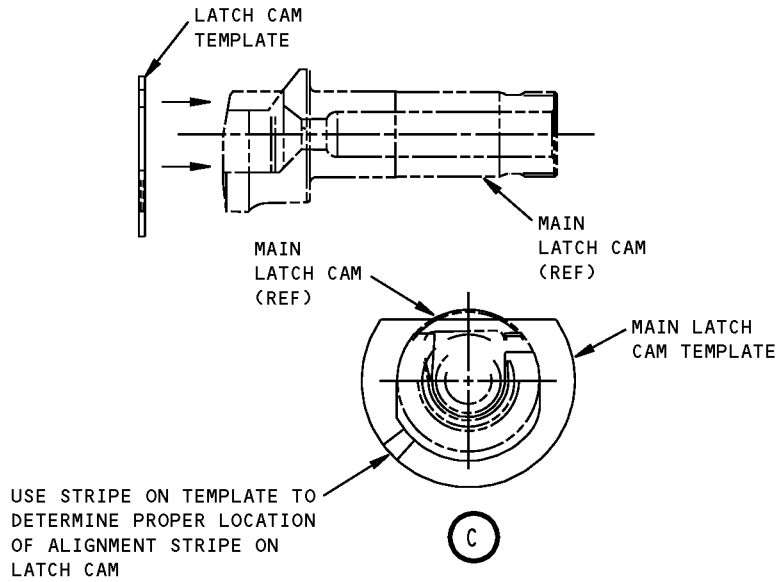
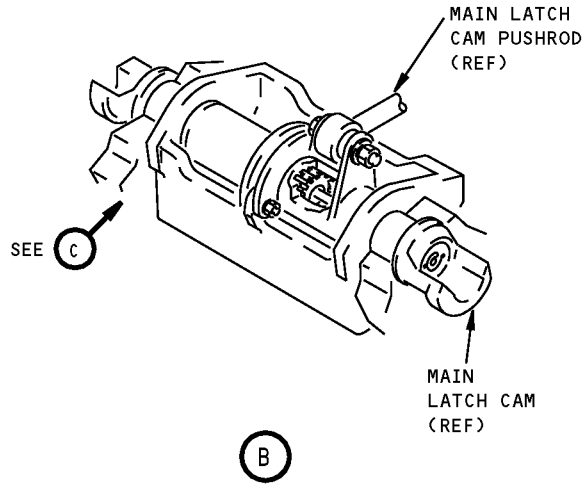

**Large Cargo Door Main Latch Fittings Verification Equipment
Figure 1 (Sheet 2 of 3)**

**767
ILLUSTRATED TOOL AND EQUIPMENT MANUAL**

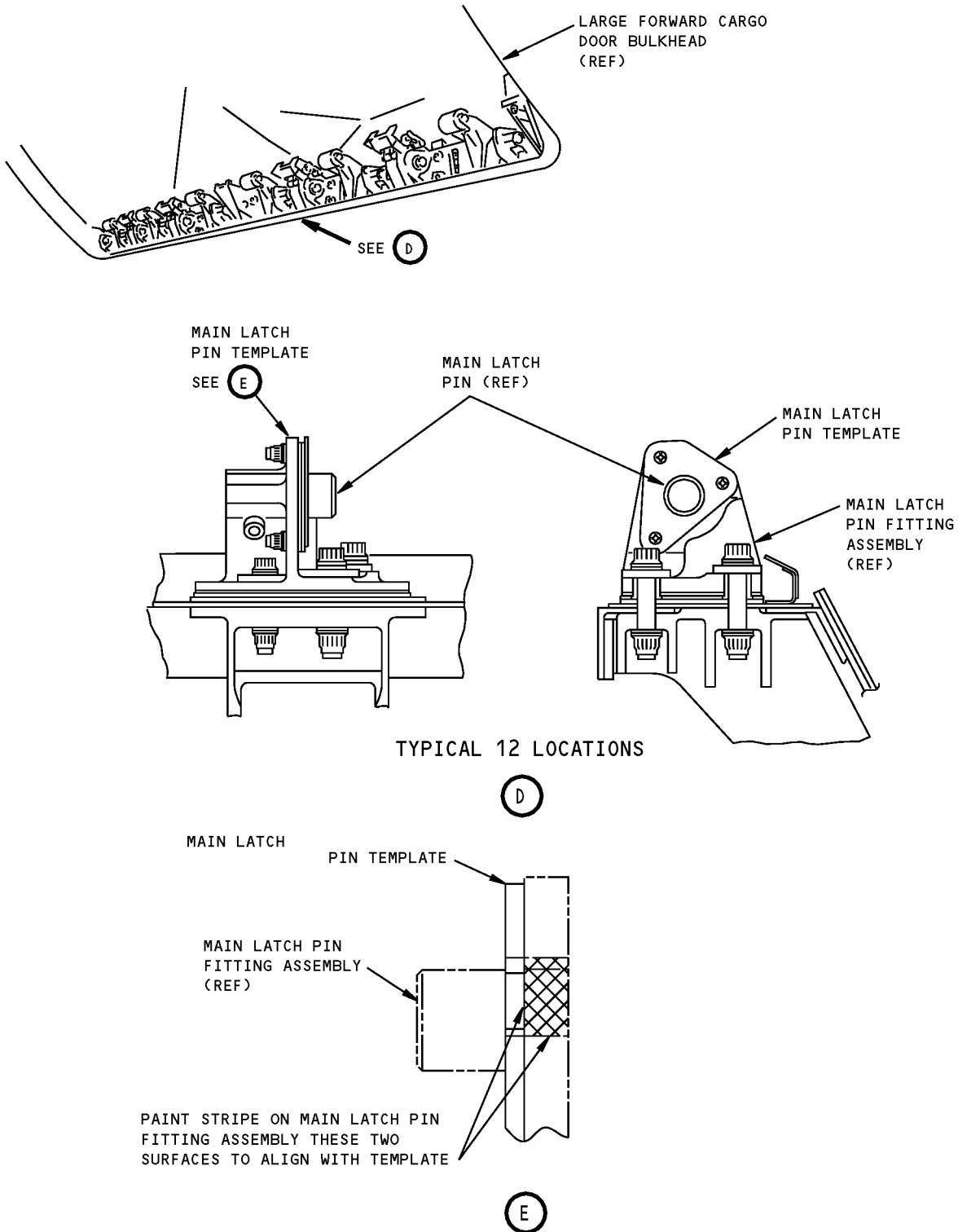

**Large Cargo Door Main Latch Fittings Verification Equipment
Figure 1 (Sheet 3 of 3)**



767

ILLUSTRATED TOOL AND EQUIPMENT MANUAL

PART NUMBER: A52031-1

NAME: RIGGING EQUIPMENT - MAIN DECK CARGO DOOR

AIRPLANE MAINTENANCE: YES

COMPONENT MAINTENANCE: NO

USAGE & DESCRIPTION: The A52031-1 rigging equipment is used on 767-200SF, -300F and -300BCF airplanes. The A52031-1 rigging equipment is used to aid in the rigging adjustments of the main deck cargo door. Refer to AMM 52-32-00 for complete usage instructions. A52031-1 consists of:

A52031-1		
QUANTITY	NOMENCLATURE	PART NUMBER
3	0.1875 RIGGING PIN ASSEMBLIES	A52031-2
1	0.3125 RIGGING PIN ASSEMBLY	A52031-3
1	MIDSPAN GO/NOGO ASSEMBLY	A52031-4
1	SKIN GAP GAGE ASSEMBLY	A52031-5
1	0.051GAGE ASSEMBLY	A52031-6
1	PLUG GAGE	CL-2-PGD-.150P-.170M
1	STORAGE BOX	

WEIGHT: 2 lbs (1 kg)

DIMENSIONS: 6 X 10 X 16 inches (152 x 254 x 6502 mm)

ILLUSTRATED TOOL AND EQUIPMENT MANUAL

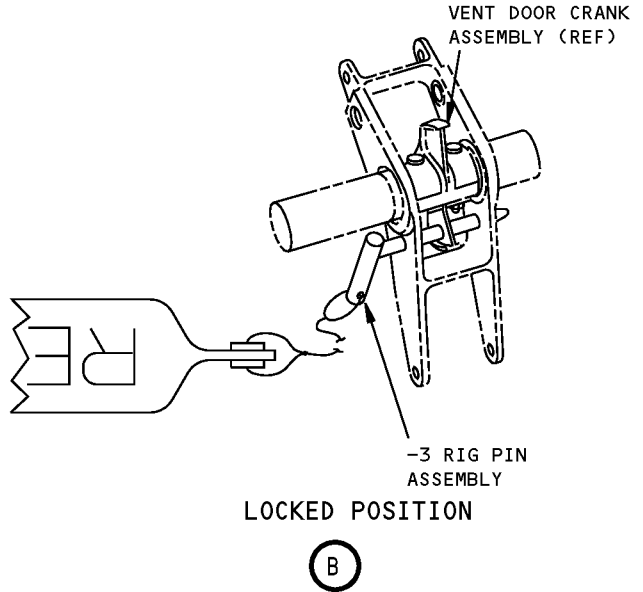
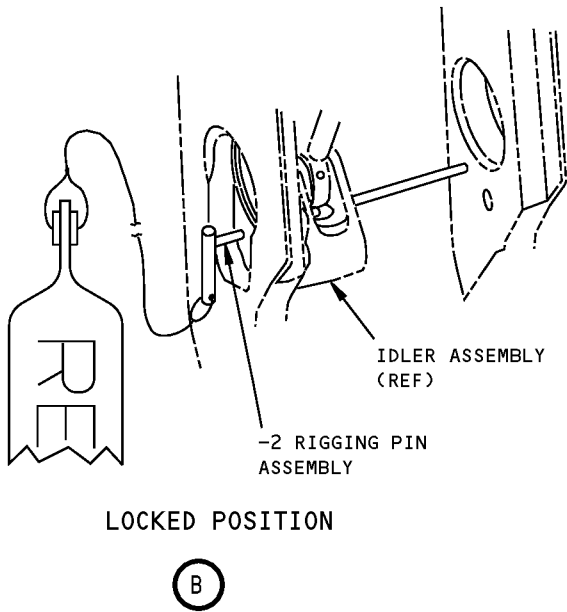
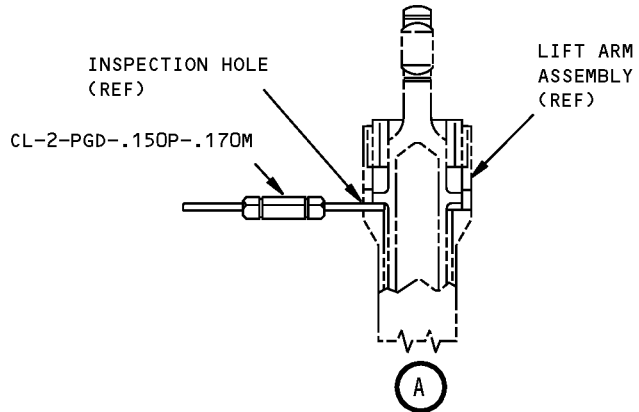
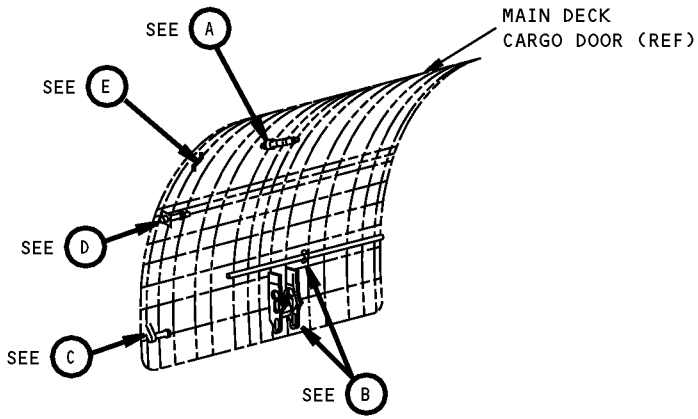

**Main Deck Cargo Door Rigging Equipment
Figure 1 (Sheet 1 of 2)**

ILLUSTRATED TOOL AND EQUIPMENT MANUAL

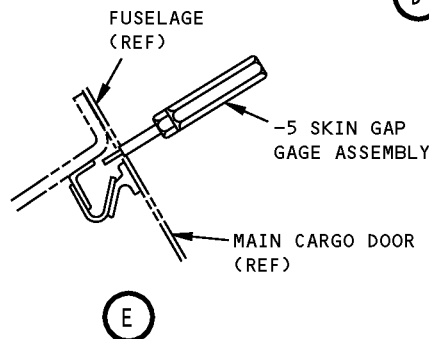
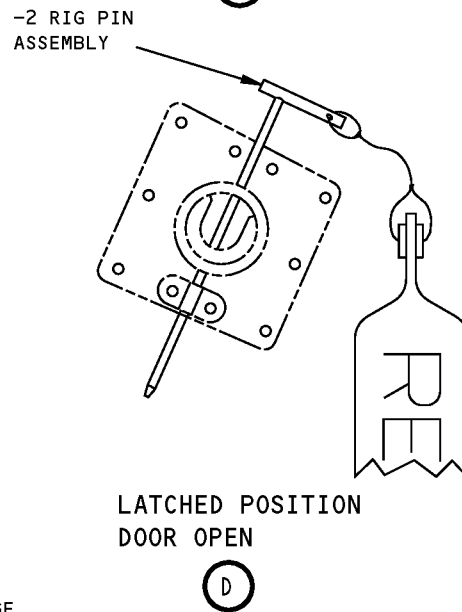
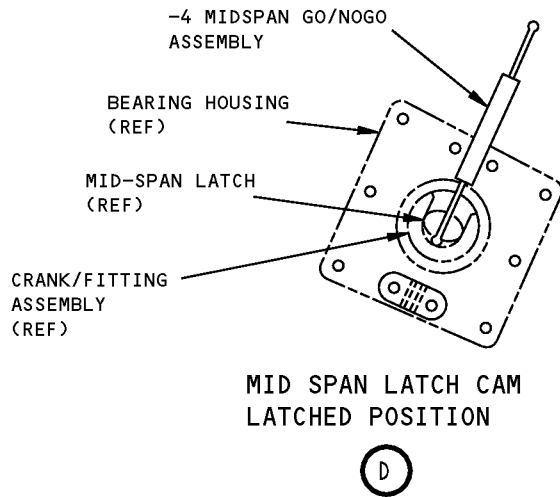
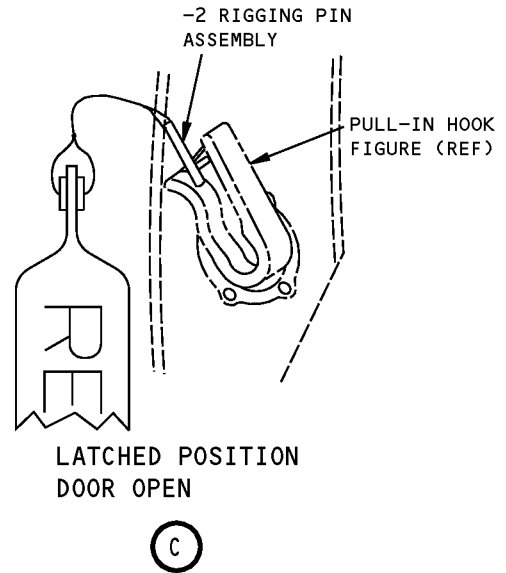
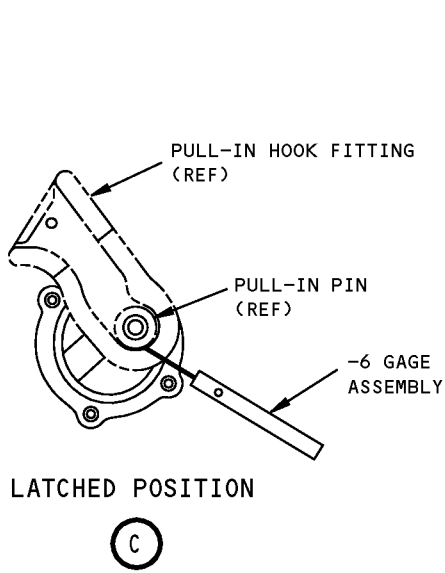

**Main Deck Cargo Door Rigging Equipment
Figure 1 (Sheet 2 of 2)**

ILLUSTRATED TOOL AND EQUIPMENT MANUAL

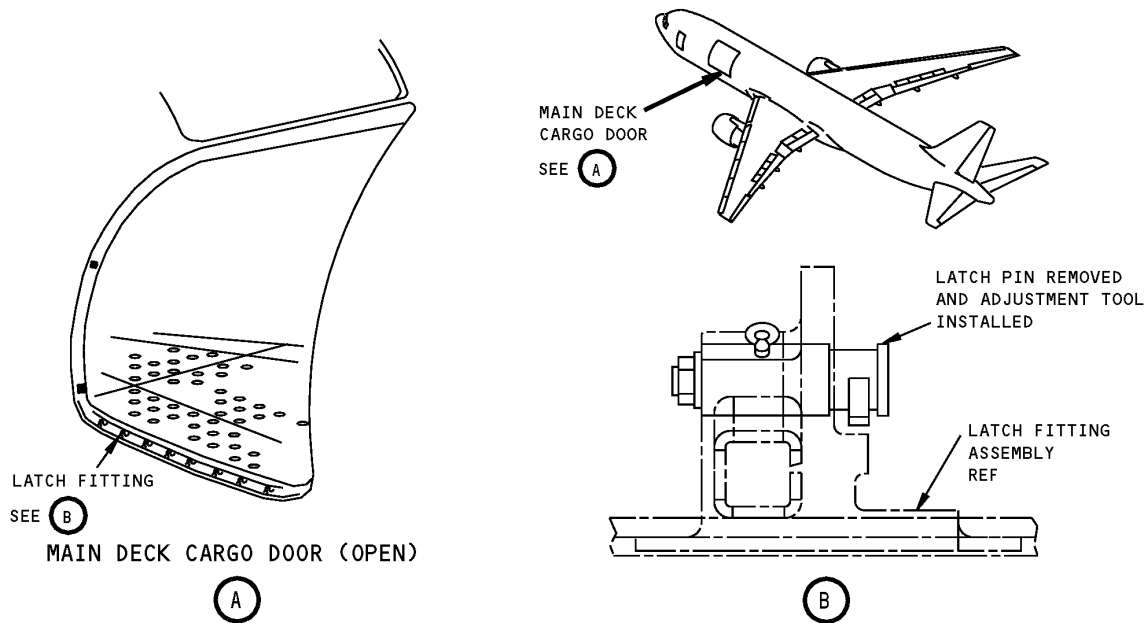
PART NUMBER: A52032-17**NAME:** ADJUSTMENT TOOL SET - LATCH PINS, MAIN DECK CARGO DOOR**AIRPLANE MAINTENANCE:** YES**COMPONENT MAINTENANCE:** NO**USAGE & DESCRIPTION:** A52032-17 adjustment tool set is used on 767-200SF, -300F & -300BCF airplanes. A52032-17 is used to aid in the adjustment of the main cargo door latch pin and latch fitting. Refer to AMM 52-32-00 for complete usage instructions. A52032-17 consists of six A52032-18 adjustment tools and six A52032-19 adjustment tools, all contained in a storage box.**WEIGHT:** 10 lbs (4.5 kg)**DIMENSIONS:** 4 x 8 x 12 inches (102 x 203 x 305 mm)**NOTE:** A52032-17 supersedes A52032-1.

Main Deck Cargo Door Latch Pins Adjustment Tool Set
Figure 1

ILLUSTRATED TOOL AND EQUIPMENT MANUAL

PART NUMBER: F70258-1

NAME: PERSONNEL SAFETY BARRIER - MAIN DECK CARGO DOOR

AIRPLANE MAINTENANCE: YES

COMPONENT MAINTENANCE: NO

USAGE & DESCRIPTION: The F70258-1 personnel safety barrier is used on 767-300F airplanes. F70258 is used to provide a personnel safety barrier for the main deck cargo door opening. Refer to the current F70258 drawing, AMM 52-32-00 and AMM52-32-01 for complete usage instructions. F70258 consists of nylon webbing, ring assemblies, webbing slides, and supplemental manufacturing instructions.

WEIGHT: 10 lbs (5 kg)

DIMENSIONS: 10 x 15 x 40 Inches (254 x 381 x 1016 mm)

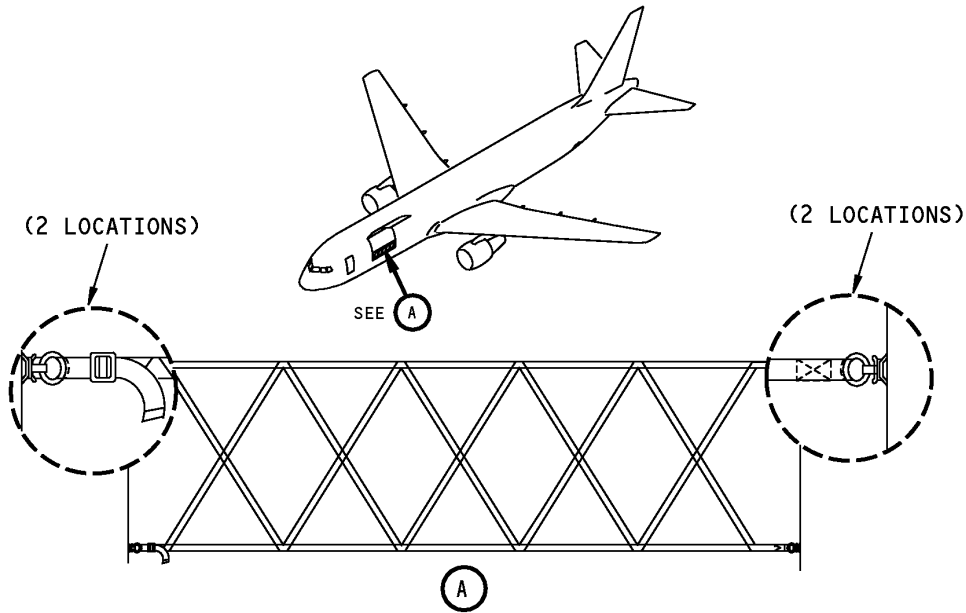

**Main Deck Cargo Door Personnel Safety Barrier
Figure 1**

ILLUSTRATED TOOL AND EQUIPMENT MANUAL

PART NUMBER: ME65B83635

NAME: TORQUE WRENCH ADAPTER - BRAKES, SIDE CARGO DOOR

AIRPLANE MAINTENANCE: YES

COMPONENT MAINTENANCE: NO

USAGE & DESCRIPTION: The ME65B83635 torque wrench adapter is used on 767-300F airplanes. This tool is used with a customer-furnished torque wrench to torque the main deck cargo door's brake assemblies on both sides of the cargo door. The ME65B83635 tool is a spanner-type wrench adapter that fits the teeth of main deck cargo doors brake assemblies. Refer to AMM 52-32-12 and current ME65B83635 drawing for further usage instructions.

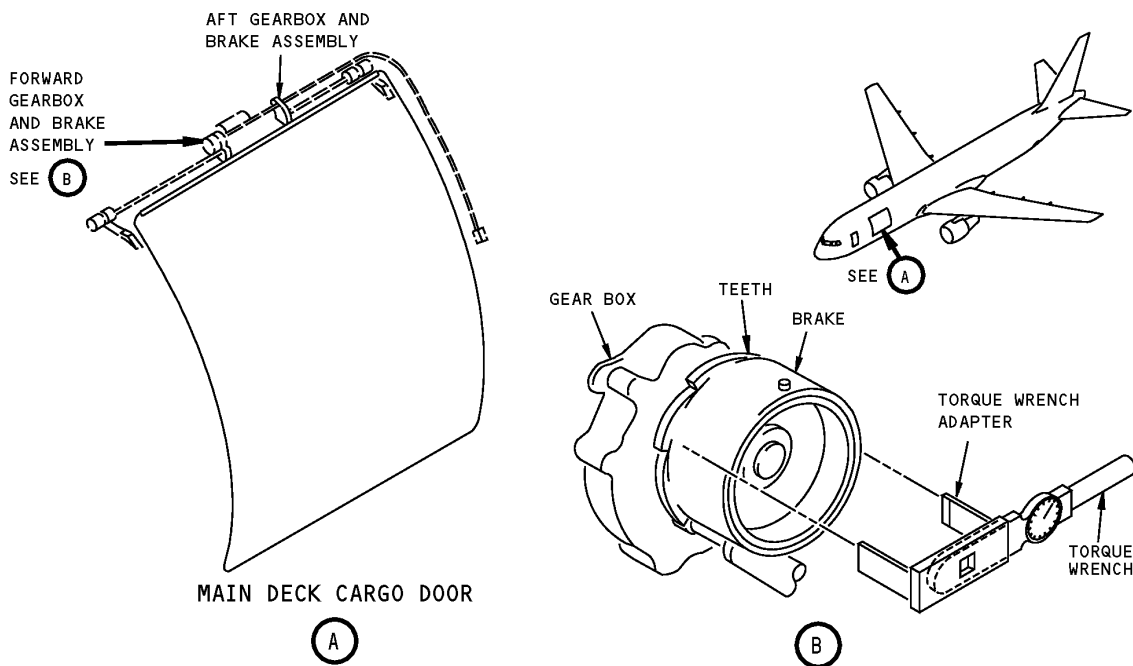

**Side Cargo Door Brakes Torque Wrench Adapter
Figure 1**



767

ILLUSTRATED TOOL AND EQUIPMENT MANUAL

PART NUMBER: A52033-1

NAME: VERIFICATION EQUIPMENT - MAIN LATCH FITTINGS, MAIN DECK CARGO DOOR

AIRPLANE MAINTENANCE: YES

COMPONENT MAINTENANCE: NO

USAGE & DESCRIPTION: The A52033-1 verification equipment is used on 767-200SF, -300BCF & -300F airplanes. A52033-1 is used as a template to aid in restoring and verifying the location of the alignment mark on the main latch pin fitting assemblies and main latch cams on the main deck cargo door. Refer to AMM 52-32-11 for complete usage instructions. A52033-1 consists of an A52033-2 cam template and an A52033-3 fitting template both contained in a storage box.

WEIGHT: 2 lbs (1 kg)

DIMENSIONS: 2 X 8 X 8 inches (51 x 203 x 203 mm)

ILLUSTRATED TOOL AND EQUIPMENT MANUAL

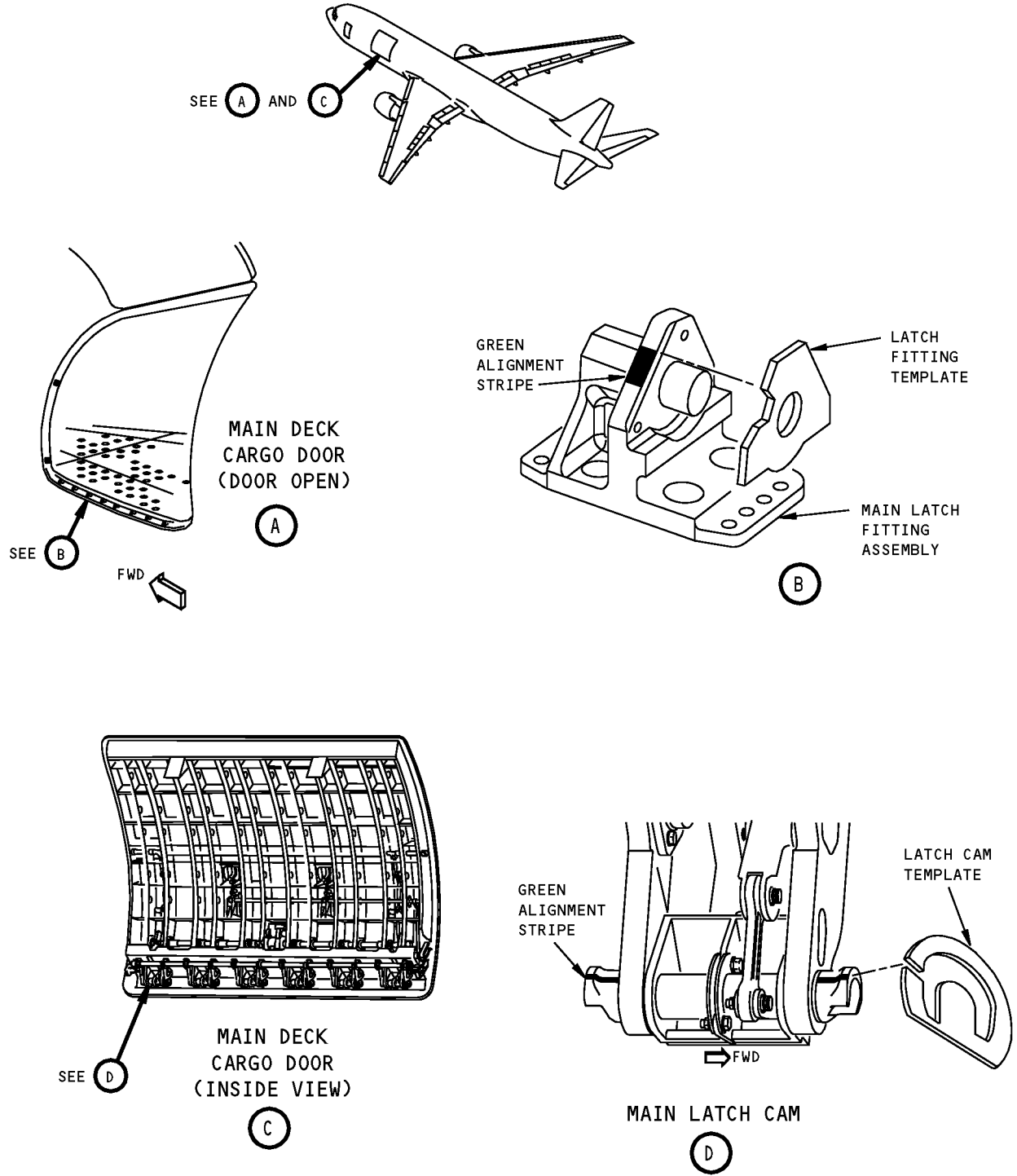

**Main Deck Cargo Door, Main Latch Fittings Verification Equipment
Figure 1**



767

ILLUSTRATED TOOL AND EQUIPMENT MANUAL

PART NUMBER: A52036-1

NAME: SLING EQUIPMENT - MAIN DECK CARGO DOOR

AIRPLANE MAINTENANCE: YES

COMPONENT MAINTENANCE: NO

USAGE & DESCRIPTION: A52036-1 sling equipment is used on 767-200SF, -300BCF & -300F airplanes. A52036-1 is used to remove and install the main deck cargo door. Refer to AMM 52-32-01 and AMM 52-32-01 for complete usage instructions. A52036-1 consists of an A52036-2 sling assembly and 16 NAS6604-15 bolts contained in a storage box.

WEIGHT: 75 lbs (34 kg)

DIMENSIONS: 24 X 30 X 56 inches (610 x 762 x 1422 mm)

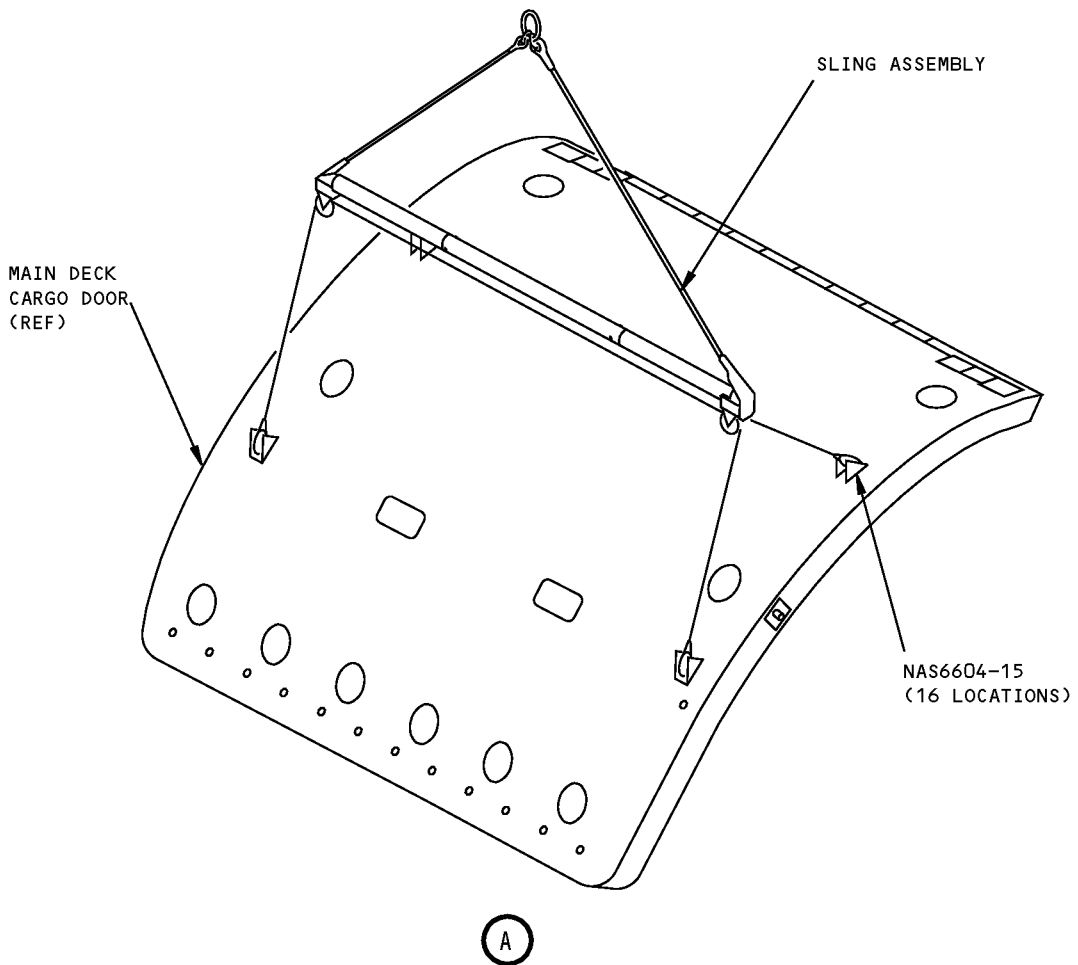
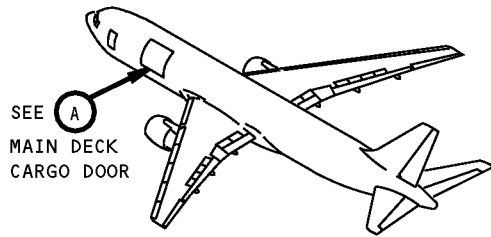

**Main Deck Cargo Door Sling Equipment
Figure 1**



767

ILLUSTRATED TOOL AND EQUIPMENT MANUAL

PART NUMBER: A52034-1

NAME: RIGGING EQUIPMENT - ROTARY ACTUATOR, MAIN DECK CARGO DOOR

AIRPLANE MAINTENANCE: YES

COMPONENT MAINTENANCE: NO

USAGE & DESCRIPTION: The A52034-1 rigging equipment is used on 767-300F airplanes. A52034 is used to aid in eliminating the backlash between the door lift system rotary actuators during actuator installation. Refer to AMM 52-32-03 for complete usage instructions. The A52034-1 rigging equipment consists of:

A52034-1		
QUANTITY	NOMENCLATURE	PART NUMBER
2	SPLINE SOCKETS	A52034-3
3	KNURLED NUTS	A52034-5
3	ALIGNMENT PINS	A52034-6
1	STORAGE BOX	

WEIGHT: 2 lbs (1 kg)

DIMENSIONS: 2 x 2 x 12 inches (51 x 51 x 305 mm)

767
ILLUSTRATED TOOL AND EQUIPMENT MANUAL

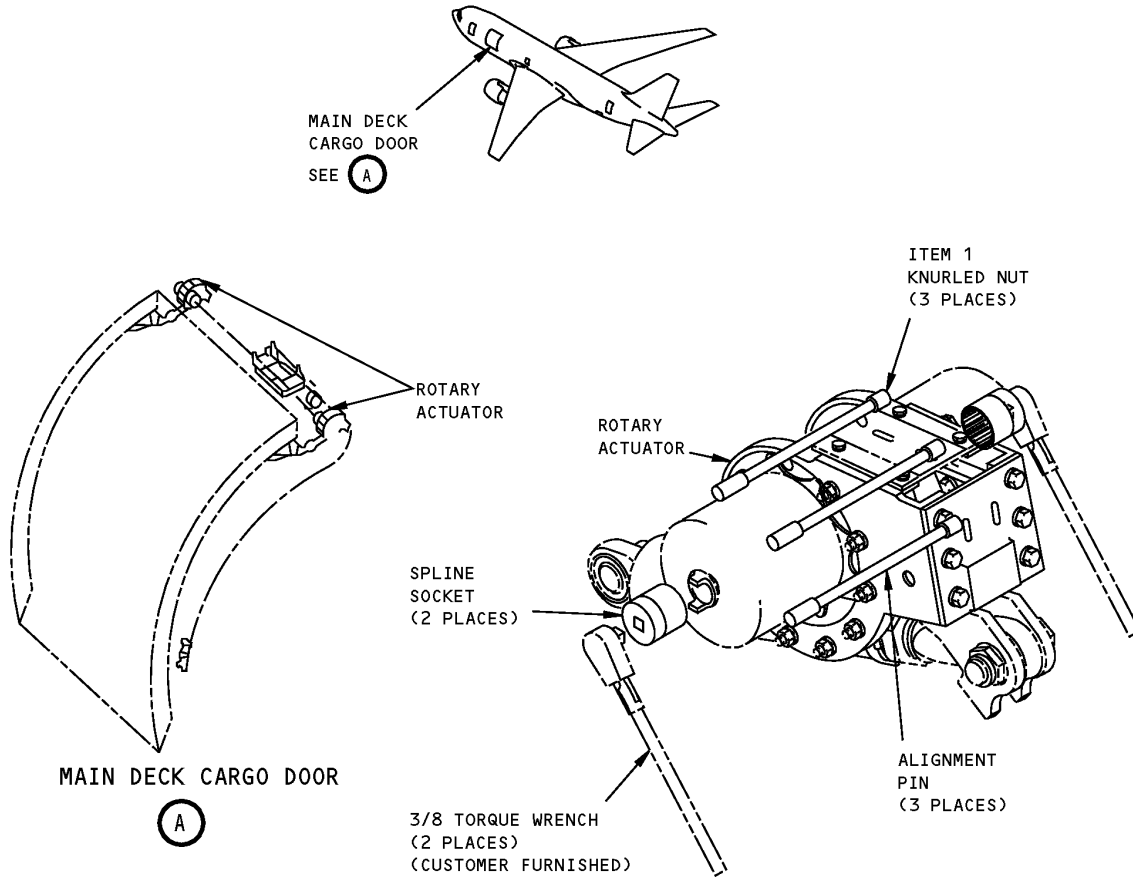

Main Deck Cargo Door Rotary Actuator Rigging Equipment
Figure 1

REPAIRABLE/REPLACEABLE PARTS			
ITEM NO.	PART NO.	NOMENCLATURE	VENDOR CODE
1	A52034-5	KNURLED NUT	



767

ILLUSTRATED TOOL AND EQUIPMENT MANUAL

PART NUMBER: A52035-1

NAME: DRIVER EQUIPMENT - INTERMEDIATE HINGE PINS, MAIN DECK CARGO DOOR

AIRPLANE MAINTENANCE: YES

COMPONENT MAINTENANCE: NO

USAGE & DESCRIPTION: A52035-1 driver equipment is used on 767-300F airplanes. The A52035 driver equipment is used in conjunction with the A52019 hinge pin driver tool set, to drive out the intermediate hinge pins on the main deck cargo door. Refer to AMM 52-32-01 for complete usage information. A52035-1 consists of:

A52035-1		
QUANTITY	NOMENCLATURE	PART NUMBER
1	SLIDE HAMMER	A52035-2
2	ROD	A52035-3
1	CHUCK KEY	A52035-4
1	DRILL CHUCK	7BA 3/8
1	STORAGE BOX	

WEIGHT: 4 lbs (1.8 kg)

DIMENSIONS: 2 x 2 x 84 inches (51 x 51 x 2134 mm)

ILLUSTRATED TOOL AND EQUIPMENT MANUAL

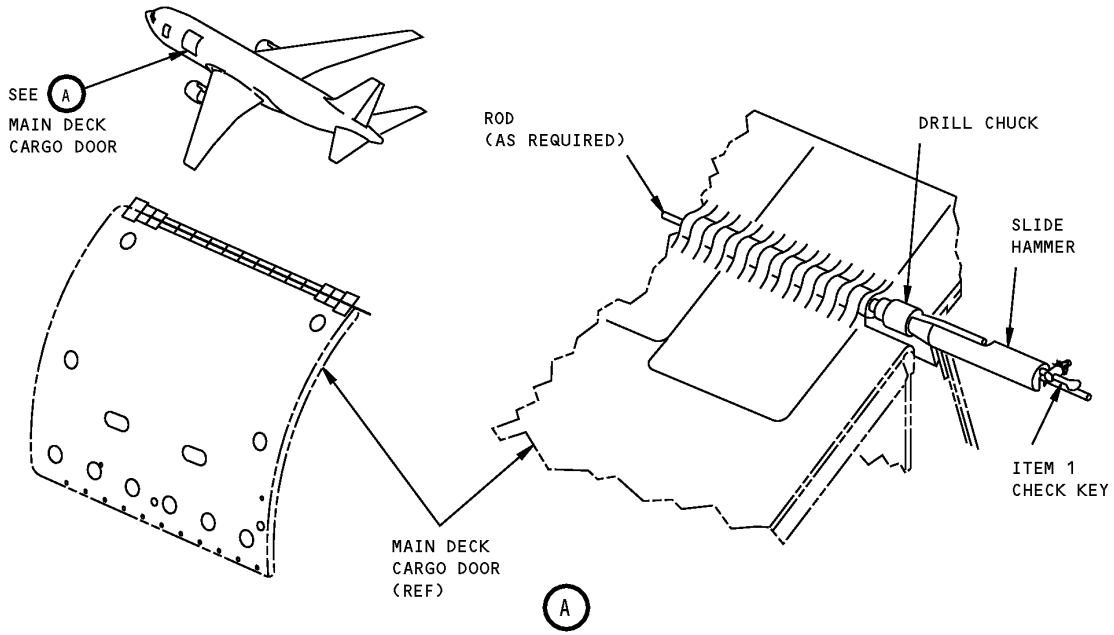

**Main Deck Cargo Door Intermediate Hinge Pins, Driver Equipment
Figure 1**

REPAIRABLE/REPLACEABLE PARTS			
ITEM NO.	PART NO.	NOMENCLATURE	VENDOR CODE
1	A52035-4	CHUCK KEY	3F776



767

ILLUSTRATED TOOL AND EQUIPMENT MANUAL

PART NUMBER: A53002-5

NAME: SAFETY BARRIER - ELECTRICAL/ELECTRONIC (E/E) ACCESS HATCH

AIRPLANE MAINTENANCE: YES

COMPONENT MAINTENANCE: NO

USAGE & DESCRIPTION: The A53002-5 safety barrier is used on all 767 airplanes. A53002 is a contoured wooden plate that fits into the intercostal installation of the electrical/electronics access hatch and prevents personnel from falling through the E/E compartment opening. Refer to the current A53002 drawing and AMM 52-48-04 for complete usage instructions. A53002-5 consists of an A53002-6 platform and two A53002-7 blocks.

WEIGHT: 9 lbs (4 kg)

DIMENSIONS: 4 x 21 x 25 inches (76 x 533 x 660 mm)

NOTE: A53002-5 supersedes A53002-1.

**767
ILLUSTRATED TOOL AND EQUIPMENT MANUAL**

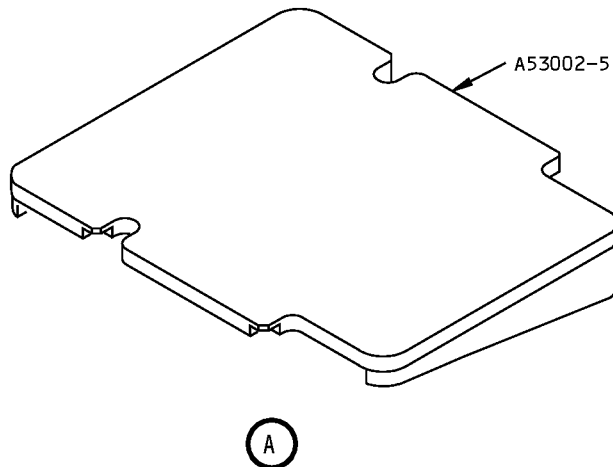
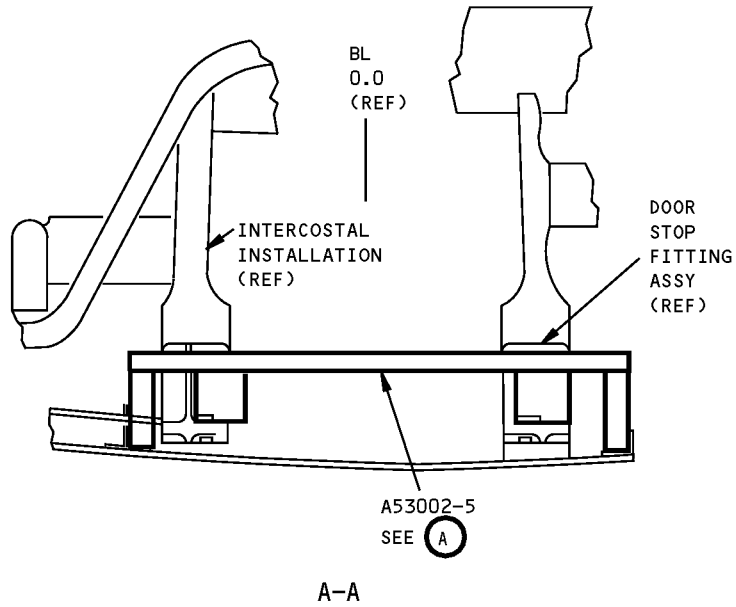
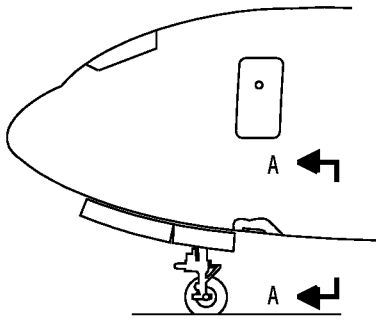

**Electrical/Electronic Access Hatch Safety Barrier
Figure 1**

ILLUSTRATED TOOL AND EQUIPMENT MANUAL

PART NUMBER: A52025-1

NAME: SERVICE PLATFORM - SERVICE ACCESS DOOR

AIRPLANE MAINTENANCE: YES

COMPONENT MAINTENANCE: NO

USAGE & DESCRIPTION: The A52025-1 service platform is used on all 767 airplanes. A52025 is an aluminum assembly that fits into the opening of the service access door and provides a safe work platform. Refer to the current A52025 drawing and AMM 52-48-00, AMM 52-48-09 and AMM 55-17-51 for complete usage instructions. A52025-1 consists of a diamond tread steel or optional aluminum plate assembly with rubber padding.

WEIGHT: 9 lbs (4 kg)

DIMENSIONS: 5 x 22 x 25 inches (127 x 559 x 635 mm)

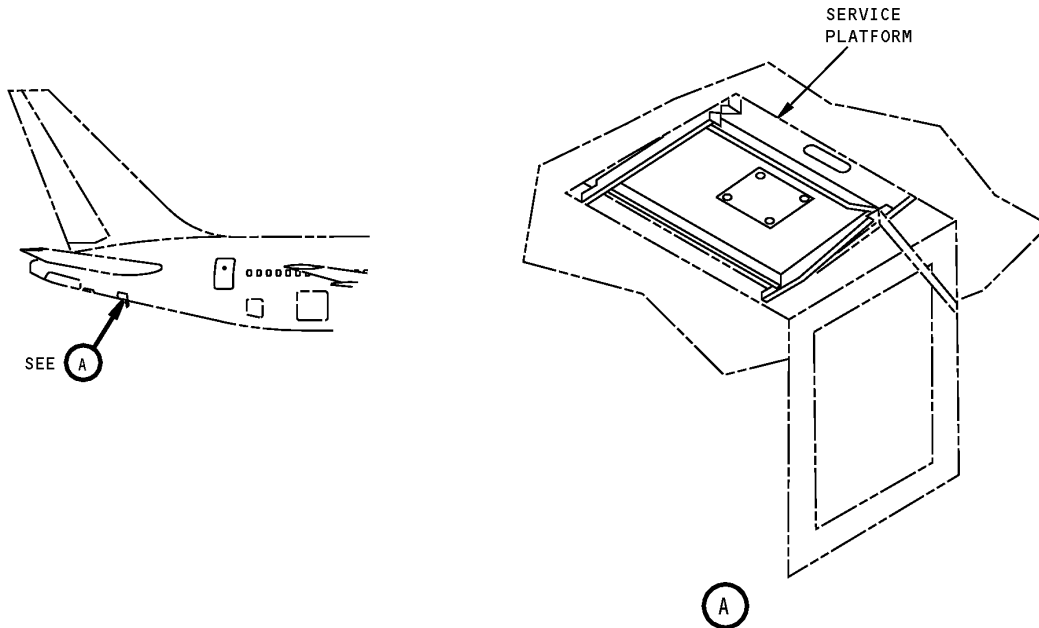

**Service Access Door Service Platform
Figure 1**



767

ILLUSTRATED TOOL AND EQUIPMENT MANUAL

PART NUMBER: J52024-2, -3

NAME: TEST EQUIPMENT - LATCH ASSEMBLY, BLOW OUT DOORS

AIRPLANE MAINTENANCE: YES

COMPONENT MAINTENANCE: NO

USAGE & DESCRIPTION: J52024-2 or -3 test equipment is used on all 767 airplanes. J52024 is used to functionally test the pressure relief feature of the 148T6604 blow out latch assembly, found on the service access and controls bay access doors. J52024 includes a tool to locate the J52024-4 hydraulic assembly (part of J52024-2 or -3). The J52024-9 gauge block locates a hydraulic cylinder on the J52024-4 hydraulic assembly. The J52024-9 gauge block is removed before use. Refer to AMM 52-48-05 and the current J52024 drawing for complete usage instructions. J52024-2 is contained in a J52024-12 storage box. J52024-3 is contained in a J52024-13 storage box. J52024-2 and -3 consists of the following:

J52024-2 OR -3		
QUANTITY	NOMENCLATURE	PART NUMBER
1	HYDRAULIC ASSEMBLY	J52024-4
1	HOOK/CORD ASSEMBLY (ONLY ON J52024-3 TEST EQUIPMENT)	J52024-5
1	PLIERS/CORD ASSEMBLY	J52024-6
1	SHORT BAR	J52024-7
2	SHOULDER SCREW	CL-33-SS
2	HOOK	J52024-8
1	GAUGE BLOCK	J52024-9
1	LONG BAR	J52024-10
1	STORAGE BOX	

WEIGHT: 25 lbs (11 kg)

DIMENSIONS: 10 x 12 x 24 inches (254 x 305 x 610 mm)

ILLUSTRATED TOOL AND EQUIPMENT MANUAL

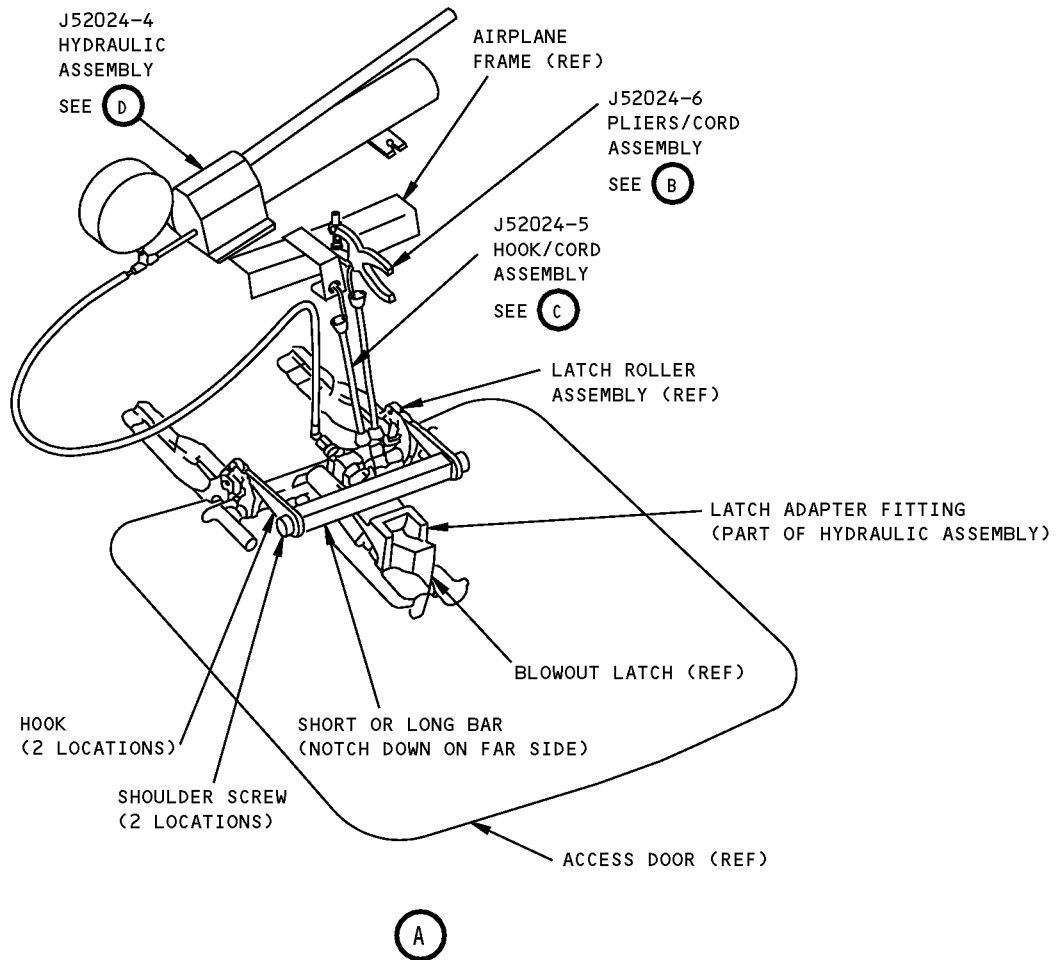
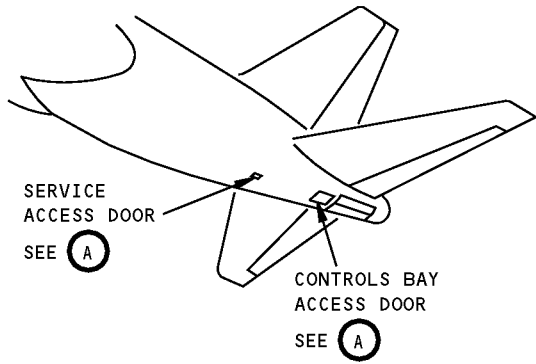

**Blow Out Doors Latch Assembly Test Equipment
Figure 1 (Sheet 1 of 2)**

ILLUSTRATED TOOL AND EQUIPMENT MANUAL

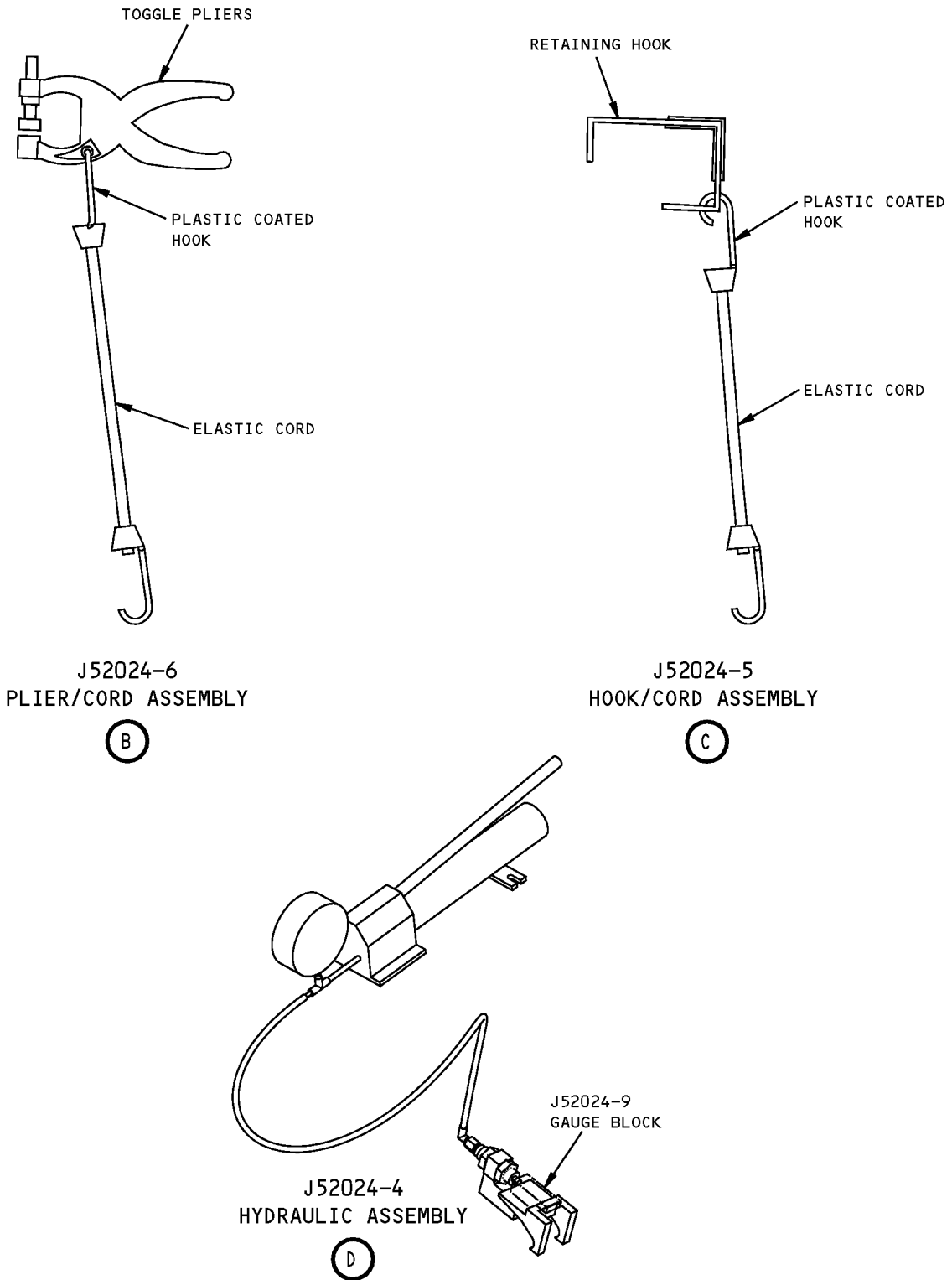

**Blow Out Doors Latch Assembly Test Equipment
Figure 1 (Sheet 2 of 2)**



767

ILLUSTRATED TOOL AND EQUIPMENT MANUAL

PART NUMBER: A52037-1

NAME: TEST BOX - FLIGHT DECK ACCESS SYSTEM (FDAS)

AIRPLANE MAINTENANCE: NO

COMPONENT MAINTENANCE: YES

USAGE & DESCRIPTION: The A52037 drawing has been transferred to BAE Systems and will no longer be revised by Boeing. The A52037 inclusion in the 767 ITEM is for information and historical purposes only.

The A52037-1 test box has limited usage on 767 airplanes that are equipped with flight deck access system (FDAS). The A52037-1 test box is used for bench testing flight deck access system (FDAS) keypad and chime module line replaceable units. Refer to CMM 52-51-03 and CMM 52-51-04 for complete usage instructions. The A52037-1 consists of only a test box.

WEIGHT: 8 lbs (3.6 kg)

DIMENSIONS: 5 x 11 x 15 inches (127 x 279 x 381 mm)

ILLUSTRATED TOOL AND EQUIPMENT MANUAL

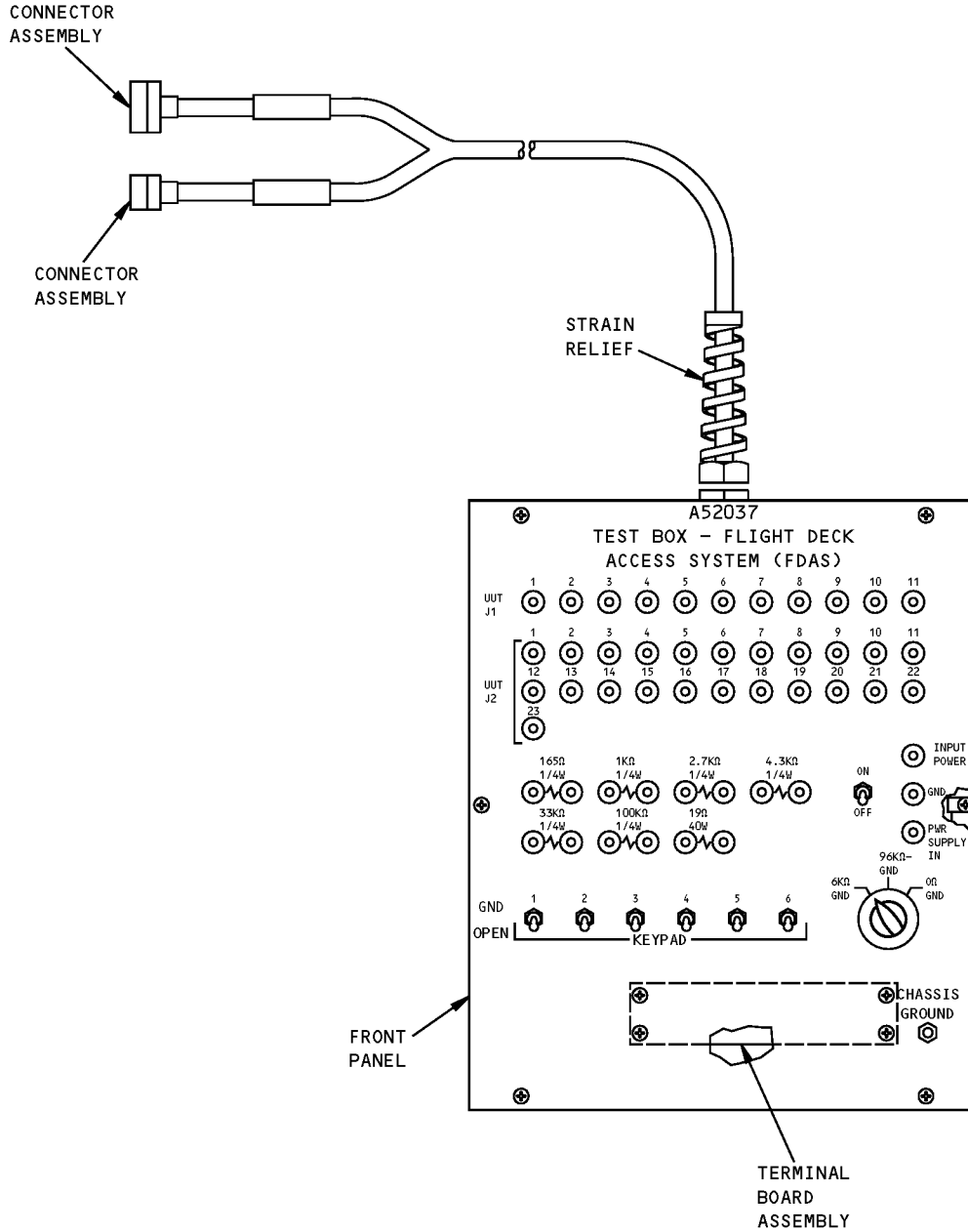

TEST BOX ASSEMBLY

**Flight Deck Access System Test Box
Figure 1**