

**CHAPTER**

**54**

**NACELLES/PYLONS**



767

ILLUSTRATED TOOL AND EQUIPMENT MANUAL

CHAPTER 54  
NACELLES/PYLONS

Subject/Page	Date	Subject/Page	Date	Subject/Page	Date
EFFECTIVE PAGES		54-50-08			
1	Apr 10/2008	1	Apr 10/2006		
2	BLANK	2	Apr 10/2007		
54-CONTENTS		3	Apr 10/2007		
1	Apr 10/2006	4	Apr 10/2007		
2	BLANK	54-50-09			
54-00-01		1	Apr 10/2006		
1	Apr 10/2006	2	Apr 10/2006		
2	Apr 10/2006	3	Apr 10/2006		
54-00-02		4	BLANK		
1	Oct 10/2006	54-50-10			
2	Apr 10/2006	1	Apr 10/2006		
54-10-01		2	Apr 10/2006		
1	Apr 10/2006	3	Apr 10/2006		
2	BLANK	4	BLANK		
54-50-01					
1	Apr 10/2006				
2	Apr 10/2006				
3	Apr 10/2006				
4	BLANK				
54-50-02					
1	Apr 10/2006				
2	Apr 10/2006				
3	Apr 10/2006				
4	Apr 10/2006				
54-50-03					
1	Apr 10/2006				
2	Apr 10/2006				
54-50-04					
1	Apr 10/2006				
2	BLANK				
54-50-05					
1	Apr 10/2006				
2	Apr 10/2006				
54-50-06					
1	Apr 10/2006				
2	BLANK				
54-50-07					
1	Apr 10/2006				
2	BLANK				

A = Added, R = Revised, O = Overflow, D = Deleted

# 54-EFFECTIVE PAGES



767

## ILLUSTRATED TOOL AND EQUIPMENT MANUAL

### TABLE OF CONTENTS

<u>Subject</u>	<u>Title</u>	<u>Part No.</u>
<b>54-</b>	<b>NACELLES/PYLONS</b>	
54-00-01	DRILL JIG - SIDE LINK, NACELLE STRUT	A54002-19, -9
54-00-02	HYDRAULIC PUMP - ENGINE "C" DUCT	B54001-30
54-10-01	PULLER EQUIPMENT - FUSE PIN	A54008-1, -13
54-50-01	SLING EQUIPMENT - STRUT UNLOAD, PIN REMOVAL/ INSTALLATION	A54001-165, -167, -168
54-50-02	SLING EQUIPMENT - STRUT REMOVAL AND INSTALLATION	A54003-1, -41, -42, -51
54-50-03	PRELOAD EQUIPMENT - STRUT INSTALLATION	A54004-27
54-50-04	SLING EQUIPMENT - STRUT, RB211-524H	A54012-1
54-50-05	SLING - DIAGONAL BRACE UNLOAD/RB211-524 ENGINE	A54007-15
54-50-06	PROOFLOAD FIXTURE RB211-524H STRUT SLING	A54009-1
54-50-07	REMOVAL TOOL - SPLIT BUSHING	B54016-1
54-50-08	REMOVAL/INSTALLATION KIT - MIDSPAR FUSE PIN	A54011-18, -24, -25, -26
54-50-09	STRUT SLING - PRELOAD/UNLOAD, DIAGONAL BRACE	G54007-165, -82, -91, -93
54-50-10	STRUT UNLOAD SLING - DIAGONAL BRACE ALIGNMENT	J54001-73, -74, -75, -76

# 54-CONTENTS

**ILLUSTRATED TOOL AND EQUIPMENT MANUAL**

**PART NUMBER: A54002-9, -19**

**NAME:** DRILL JIG - SIDE LINK, NACELLE STRUT

**AIRPLANE MAINTENANCE:** YES

**COMPONENT MAINTENANCE:** NO

**USAGE & DESCRIPTION:** The A54002-9 drill jig is used on 767-200 and -300 airplanes. The A54002-19 drill jig is used on 767-400 airplanes. A54002 locates and holds the true dimension length of the side links of the nacelle strut for drilling the fasteners. A54002 is used when replacing a side link. The tool is an adjustable holding jig side link assembly. Refer to AMM 54-51-01 for complete usage instructions. The A54002-9 consists of an A54002-10 jig assembly contained in a storage box. The A54002-19 consists of a A54002-20 jig assembly contained in a storage box.

**WEIGHT:** 5 lbs (2 kg)

**DIMENSIONS:** 4 x 6 x 12 inches (102 x 152 x 305 mm)

**NOTE:** A54002-9 supersedes A54002-1.

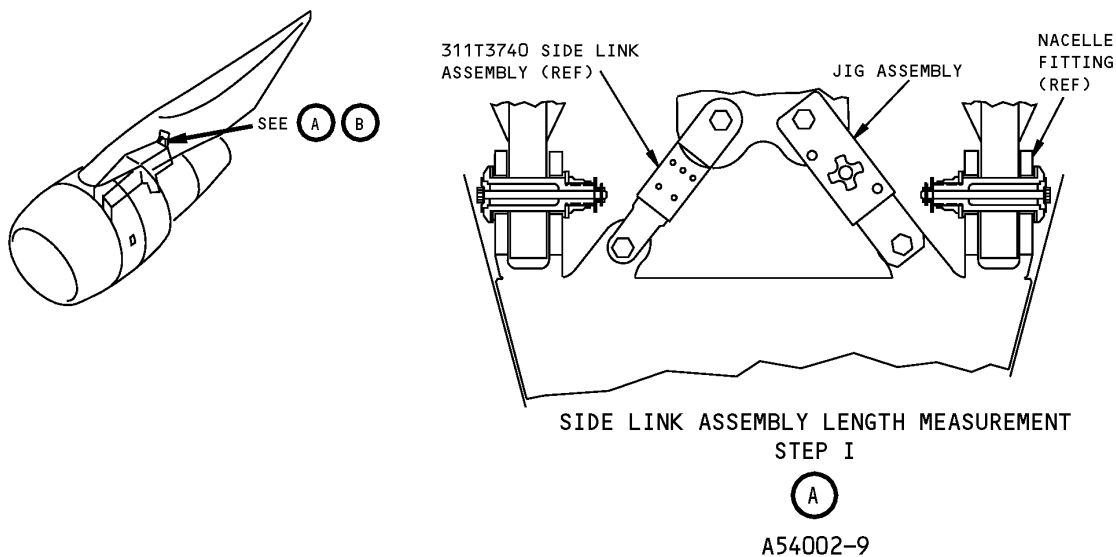

**Nacelle Strut Side Link Drill Jig  
Figure 1 (Sheet 1 of 2)**

**ILLUSTRATED TOOL AND EQUIPMENT MANUAL**

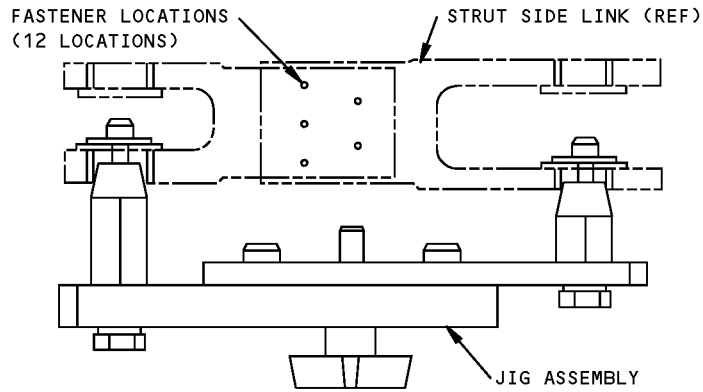

HOLDING JIG FOR DRILLING  
STEP II

(A)

A54002-9

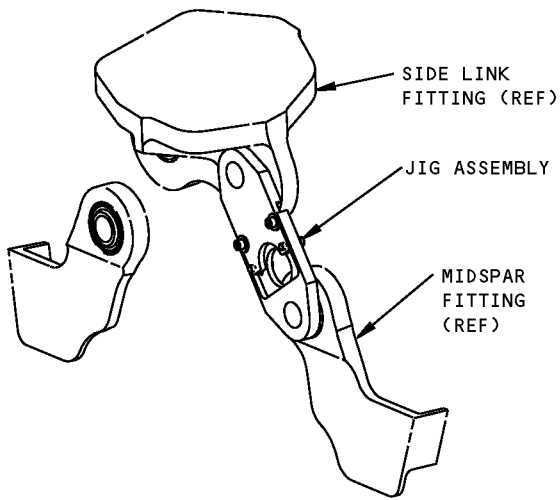

SIDE LINK ASSEMBLY LENGTH MEASUREMENT  
STEP I

(B)

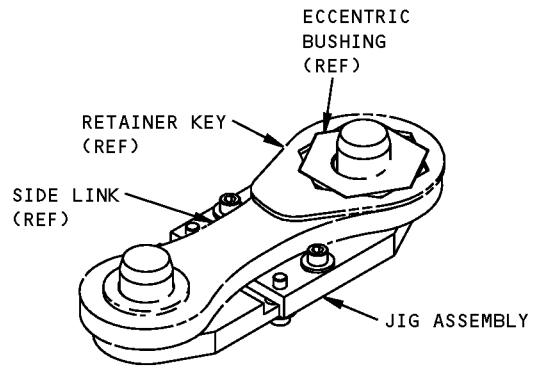

HOLDING JIG FOR DRILLING  
STEP II

(B)

A54002-19

**Nacelle Strut Side Link Drill Jig  
Figure 1 (Sheet 2 of 2)**

**ILLUSTRATED TOOL AND EQUIPMENT MANUAL**

**PART NUMBER: B54001-30**

**NAME:** HYDRAULIC PUMP - ENGINE "C" DUCT

**AIRPLANE MAINTENANCE:** YES

**COMPONENT MAINTENANCE:** NO

**USAGE & DESCRIPTION:** The B54001-30 hydraulic pump is used on all 767 airplanes. B54001 is used to open the "C" duct halves for engine maintenance. B54001 is a hydraulic pump that connects to the duct halves and applies sufficient pressure to open the duct halves. Refer to AMM 78-31-00, AMM 78-31-08, and the current B54001 drawing for additional usage instructions. B54001-1 consists of a B54001-31 pump assembly contained in a storage case.

**WEIGHT:** 40 lbs (18 kg)

**DIMENSIONS:** 8 x 13 x 21 inches 203 x 330 x 533 mm)

**NOTE:** B54001-30 supersedes B54001-25.

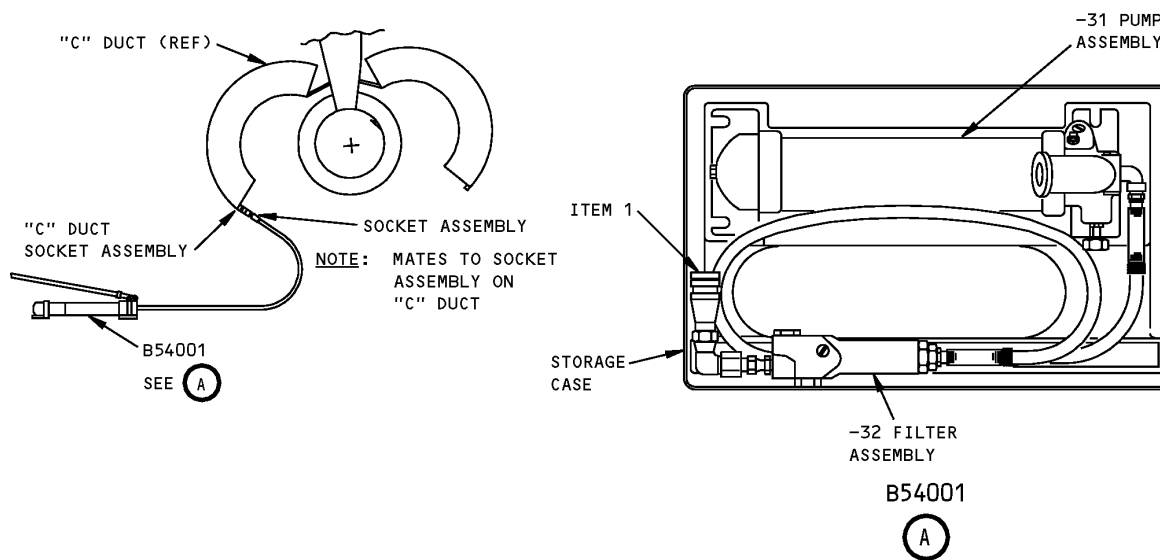

**Engine "C" Duct Hydraulic Pump  
Figure 1**



767

ILLUSTRATED TOOL AND EQUIPMENT MANUAL

REPAIRABLE/REPLACEABLE PARTS			
ITEM NO.	PART NO.	NOMENCLATURE	VENDOR CODE
1	SD-2-HK	DUST CAP	V73992
2	LLSDC-2-HK(S)	DUST CAP (OPTIONAL)	V73992

## ILLUSTRATED TOOL AND EQUIPMENT MANUAL

**PART NUMBER: A54008-1, -13****NAME:** PULLER EQUIPMENT - FUSE PIN**AIRPLANE MAINTENANCE:** YES**COMPONENT MAINTENANCE:** NO

**USAGE & DESCRIPTION:** The A54008-1 puller equipment is used on all 767 airplanes except 767-400. The A54008-13 puller equipment is used on all 767 airplanes. A54008 is used to remove strut attachment fuse pins at the midspar fittings. Refer to AMM 54-51-01 for complete usage instructions. The A54008-1 consists of an A54008-2 puller assembly, an A54008-4 pad assembly contained in a storage box. The A54008-13 consists of an A54008-14 puller assembly, an A54008-4 pad assembly contained in a storage box.

**WEIGHT:** 3 lbs (1.4 kg)**DIMENSIONS:** 4 x 4 x 14 inches (102 x 102 x 356 mm)

**NOTE:** A54011 replaces A54008 for future procurement.  
A54011-13 replaces A54008-1 for future procurement.

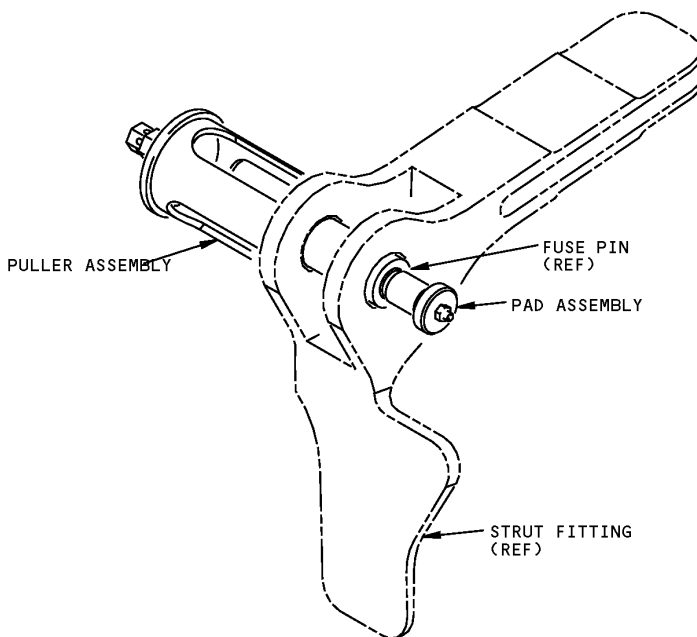

**Fuse Pin Puller Equipment  
Figure 1**





767

## ILLUSTRATED TOOL AND EQUIPMENT MANUAL

**PART NUMBER: A54001-165, -167, -168**

**NAME:** SLING EQUIPMENT - STRUT UNLOAD, PIN REMOVAL/INSTALLATION

**AIRPLANE MAINTENANCE:** YES

**COMPONENT MAINTENANCE:** NO

**USAGE & DESCRIPTION:** The A54001-165 or -168 sling equipment are used on 767 airplanes equipped with CF6-80A and CF6-80C2 engines. The A54001-167 sling equipment is used on 767 airplanes equipped with JT9D-7R4 and PW4000 engines. A54001 supports the engine while unloading the strut diagonal brace during removal and installation of the brace without removing the engine. Refer to AMM 54-51-03, AMM 54-51-04 and AMM 54-51-05 for complete usage instructions. The A54001-165 consists of an A54001-127 sling assembly contained in a storage box. The A54001-167 consists of an A54001-128 sling assembly, an A342-1 master link contained in a storage box. The A54001-168 consists of an A54001-158 sling assembly contained in a storage box.

**WEIGHT:** 160 lbs (73 kg)

**DIMENSIONS:**  
A54001-165 - 7 x 93 x 127 inches (178 x 2362 x 3226 mm)  
A54001-167 - 7 x 93 x 135 inches (178 x 2362 x 3429)  
A54001-168 - 7 x 93 x 127 inches (178 x 2362 x 3226)

**NOTE:** A54001-168 replaces A54001-165 for future procurement.  
A54001-165, -167 and -168 supersedes A54001-136, -137 and -157 respectively.

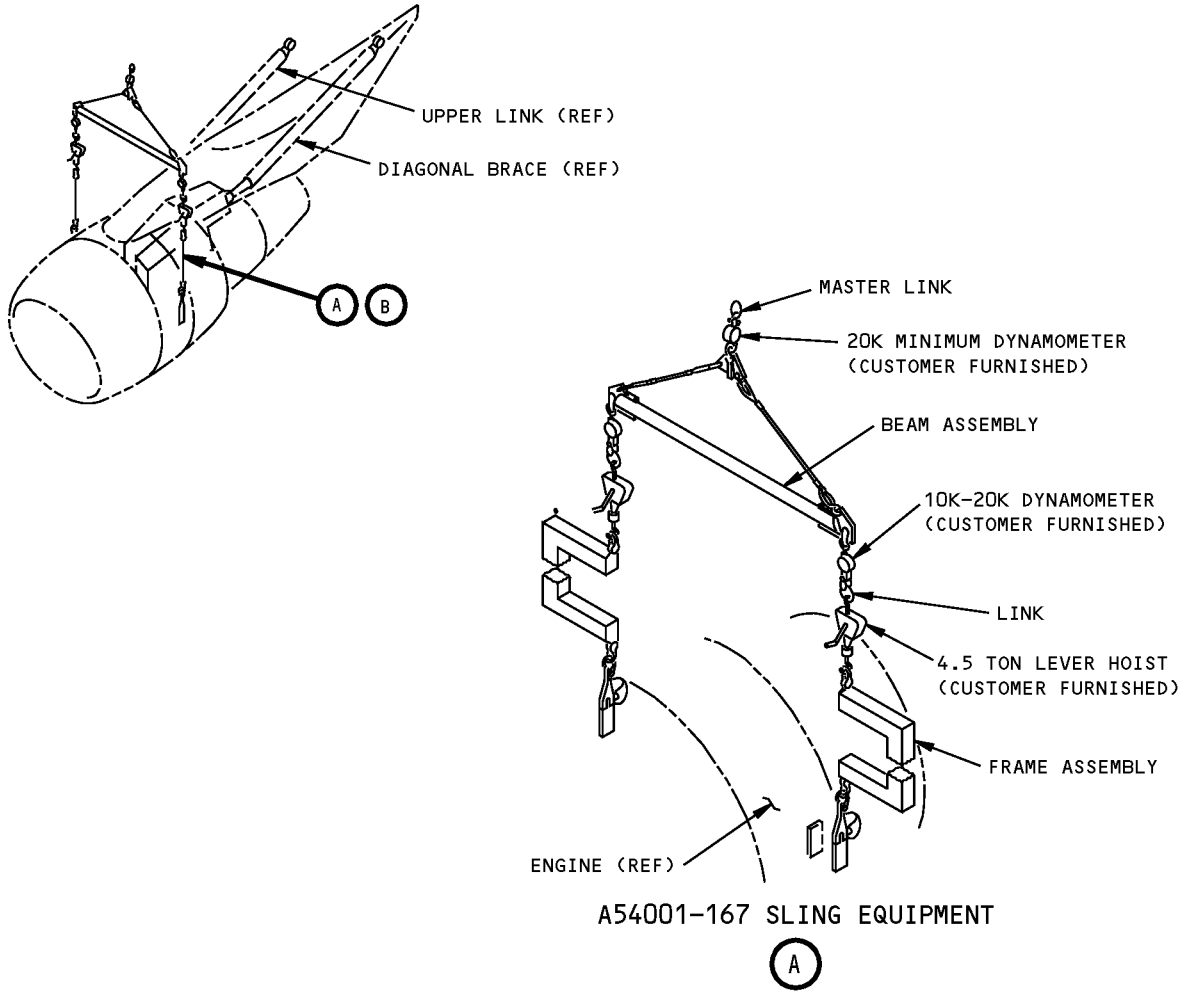

**Pin Removal/Installation, Strut Unload, Sling Equipment**  
**Figure 1 (Sheet 1 of 2)**

**767**  
**ILLUSTRATED TOOL AND EQUIPMENT MANUAL**

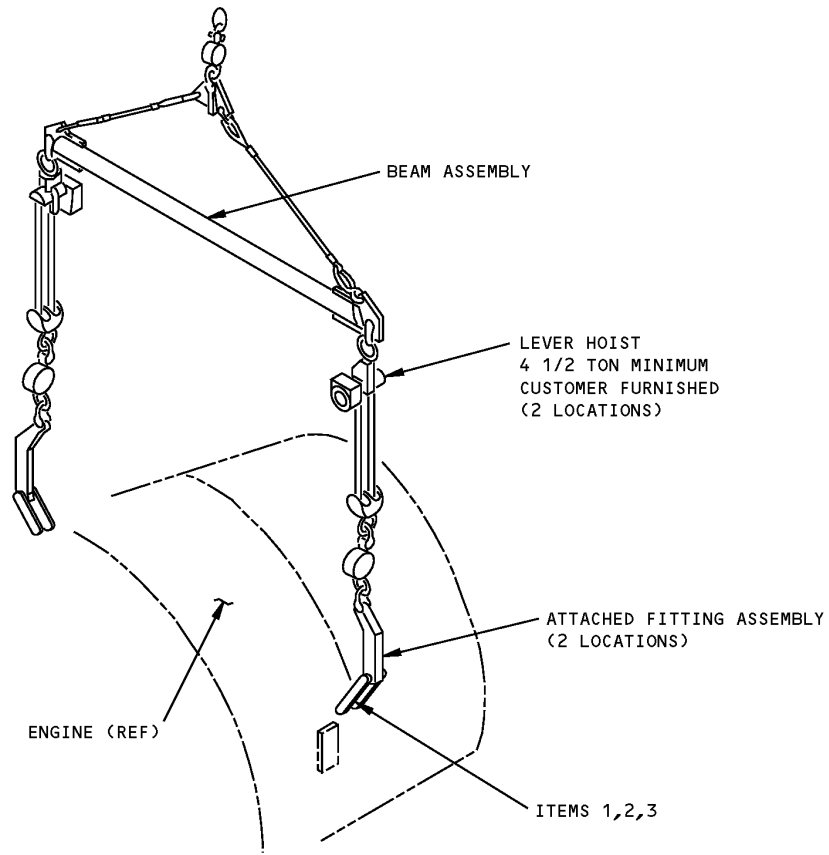

A54001-165 AND -168 SLING EQUIPMENT

B

**Pin Removal/Installation, Strut Unload, Sling Equipment**  
**Figure 1 (Sheet 2 of 2)**

REPAIRABLE/REPLACEABLE PARTS			
ITEM NO.	PART NO.	NOMENCLATURE	VENDOR CODE
1	A54001-95	BOLT	
2	A54001-96	NUT	
3	A54001-162	BOLT	



767

## ILLUSTRATED TOOL AND EQUIPMENT MANUAL

**PART NUMBER:** A54003-1, -41, -42, -51

**NAME:** SLING EQUIPMENT - STRUT REMOVAL AND INSTALLATION

**AIRPLANE MAINTENANCE:** YES

**COMPONENT MAINTENANCE:** NO

**USAGE & DESCRIPTION:** The A54003-1 or -51 sling assembly is used for 767 airplanes equipped with JT9D-7R4 and PW4000 engines. The A54003-41 sling equipment is used for 767 airplanes equipped with CF6-80A engines. The A54003-42 sling equipment is used for 767 airplanes equipped with CF6-80C2 engines. A54003 is used to remove or install engine struts by using a customer-furnished overhead crane or other lifting device. Refer to AMM 54-51-01, AMM 54-51-03, AMM 54-51-04 and AMM 54-51-05 for complete usage instructions. The A54003-41 and -42 are applicable for existing airplanes that are equipped with 5/16 inch bolts and are also applicable if service bulletin 767-54-33 has been incorporated or those delivered with 3/8 inch attachment bolts. A54003-1, -41, -42 and -51 consists of:

A54003-1		
QUANTITY	NOMENCLATURE	PART NUMBER
1	TOP FRAME ASSEMBLY	A54003-4
1	SIDE FRAME ASSEMBLY	A54003-5
1	FRAME ASSEMBLY	A54003-6
1	P & W FRONT FITTING ASSEMBLY	A54003-36
2	P & W BACK FITTING ASSEMBLY	A54003-8
VARIOUS	CONNECTING HARDWARE	

A54003-41		
QUANTITY	NOMENCLATURE	PART NUMBER
1	LEFT HAND 5/16 AFT FITTING	A54003-9
1	RIGHT HAND 5/16 AFT FITTING	A54003-10
1	GE SLING ASSEMBLY	A54003-43
1	LEFT HAND 3/8 AFT FITTING	A54003-45
1	RIGHT HAND 3/8 AFT FITTING	A54003-46
1	STORAGE BOX	

A54003-42		
QUANTITY	NOMENCLATURE	PART NUMBER
1	LEFT HAND 5/16 AFT FITTING	A54003-9



767

ILLUSTRATED TOOL AND EQUIPMENT MANUAL

A54003-42		
QUANTITY	NOMENCLATURE	PART NUMBER
1	RIGHT HAND 5/16 AFT FITTING	A54003-10
1	GE SLING ASSEMBLY	A54003-44
1	LEFT HAND 3/8 AFT FITTING	A54003-45
1	RIGHT HAND 3/8 AFT FITTING	A54003-46
1	STORAGE BOX	

A54003-51		
QUANTITY	NOMENCLATURE	PART NUMBER
1	P & W SLING ASSEMBLY	A54003-1
1	STORAGE BOX	

**WEIGHT:** 430 lbs (195 kg)

**DIMENSIONS:** 45 x 58 x 100 inches (1143 x 1473 x 2540 mm)

**NOTE:** A54003-51 replaces A54003-1 for future procurement.  
A54003-41 and -42 supersede A54003-2 and -3, respectively.

**ILLUSTRATED TOOL AND EQUIPMENT MANUAL**

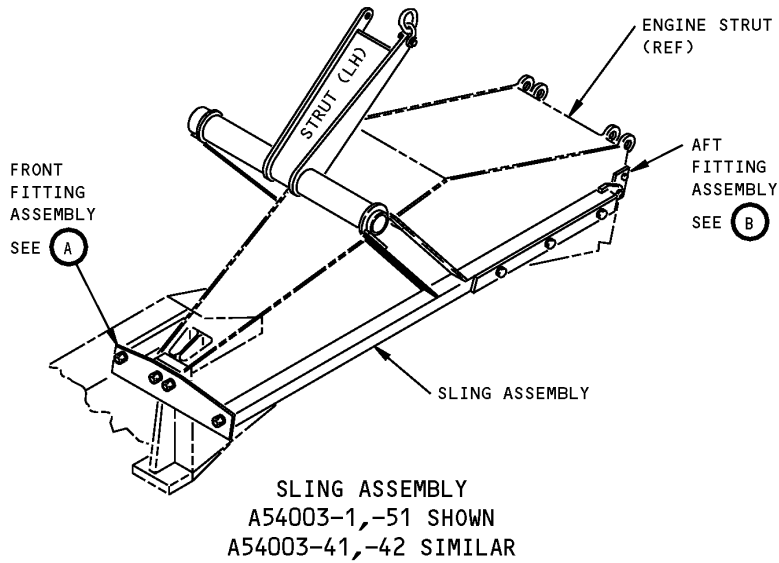

**Strut Removal and Installation Sling Equipment  
Figure 1 (Sheet 1 of 2)**

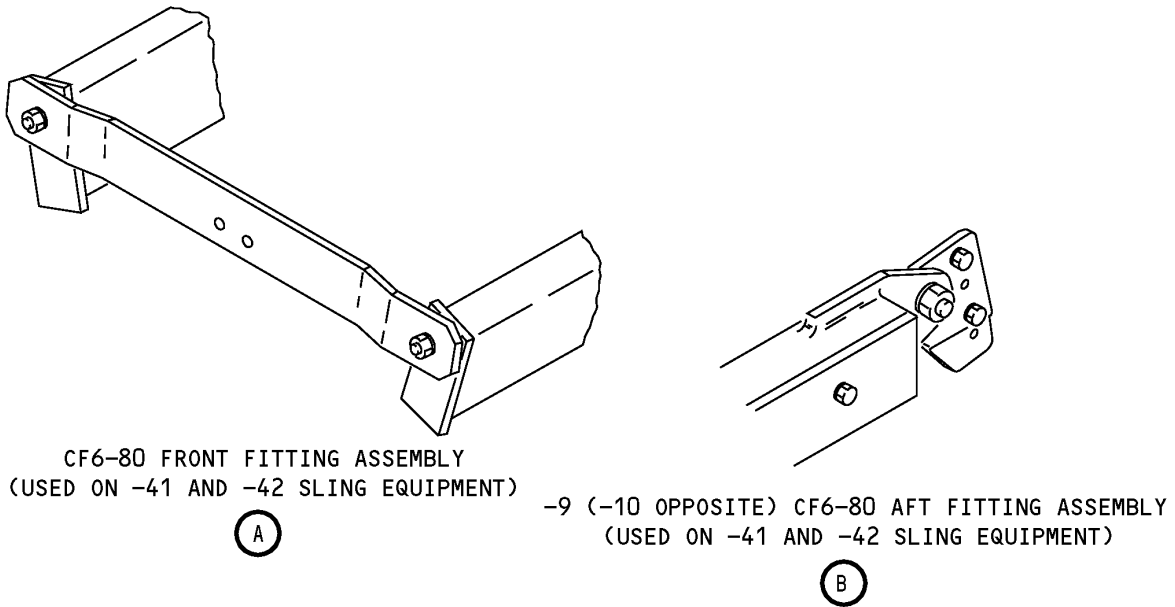

**Strut Removal and Installation Sling Equipment  
Figure 1 (Sheet 2 of 2)**



767

ILLUSTRATED TOOL AND EQUIPMENT MANUAL

REPAIRABLE/REPLACEABLE PARTS			
ITEM NO.	PART NO.	NOMENCLATURE	VENDOR CODE
1	AN960-616	WASHER	
2	AN960-716	WASHER	
3	MS21044N6	NUT	
4	MS21044N7	NUT	
5	NAS6605-17	BOLT	
6	NAS6606-13	BOLT	
7	NAS6607-13	BOLT	
8	NAS6607-16	BOLT	
9	G-341-5/8	SLING LINK	V75535
10	G-2130-1/2	SHACKLE	V75535
11	F70308-15	PROOF LOAD TAG	

**ILLUSTRATED TOOL AND EQUIPMENT MANUAL**

**PART NUMBER: A54004-27**

**NAME:** PRELOAD EQUIPMENT - STRUT INSTALLATION

**AIRPLANE MAINTENANCE:** YES

**COMPONENT MAINTENANCE:** NO

**USAGE & DESCRIPTION:** The A54004-27 preload equipment is used on 767 airplanes equipped with GE or P & W engines. A54004 is used to preload the engine strut, providing correct alignment of diagonal brace pins. Refer to AMM 54-51-01, AMM 54-51-03, AMM 54-51-04 and AMM 54-51-05 for complete usage instructions. A54004-27 consists of an A54004-33 base assembly, an A54004-20 cylinder assembly, an A54004-21 pump assembly, an A54004-28 outer tube assembly, all contained in a storage box.

**WEIGHT:** 250 lbs (113 kg)

**DIMENSIONS:** 14 x 96 x 98 inches (356 x 2438 x 2489 mm)

**NOTE:** G54007 or J54001 replaces A54004-27 for future procurement. A54004-27 supersedes A54004-19.

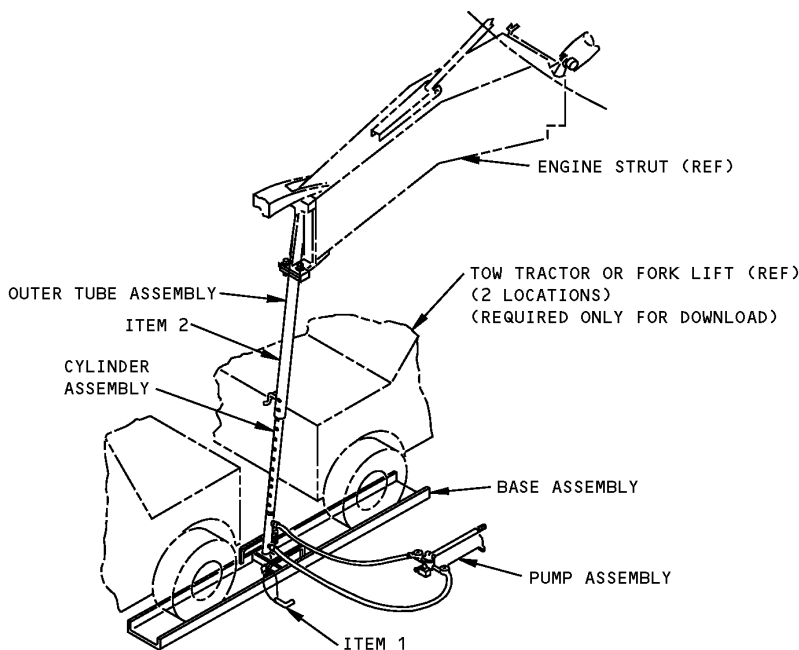

**Strut Installation Preload Equipment  
Figure 1**





767

ILLUSTRATED TOOL AND EQUIPMENT MANUAL

REPAIRABLE/REPLACEABLE PARTS			
ITEM NO.	PART NO.	NOMENCLATURE	VENDOR CODE
1	NAS1341C52.0D	BALL LOCK PIN	
2	CL-8-BLPL-3.00	BALL LOCK PIN	V99862

## ILLUSTRATED TOOL AND EQUIPMENT MANUAL

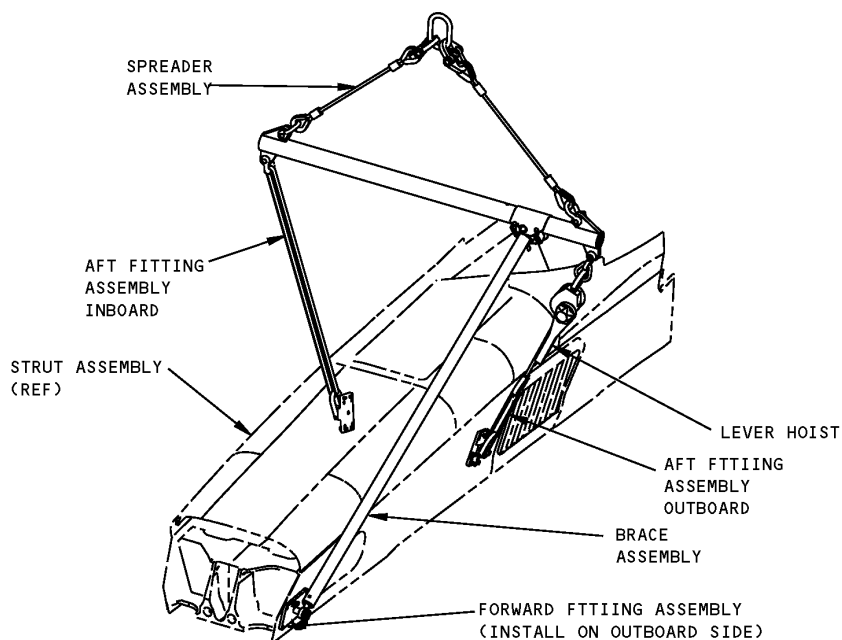
**PART NUMBER: A54012-1****NAME:** SLING EQUIPMENT - STRUT, RB211-524H**AIRPLANE MAINTENANCE:** YES**COMPONENT MAINTENANCE:** NO**USAGE & DESCRIPTION:** The A54012-1 sling equipment is used on 767 airplanes equipped with RB211-524H engines. A54012 is used to remove and install the RB211-524H engine strut. Refer to the current A54012 drawing and AMM 54-51-01 for complete usage information. A54012-1 consists of an A54012-2 sling assembly contained in a storage box.**WEIGHT:** 140 lbs (64 kg)**DIMENSIONS:** 15 x 15 x 75 inches (381 x 381 x 1905 mm)**NOTE:** A54012-1 supersedes A54005-1.

**RB211-524H Strut Sling Equipment**  
**Figure 1**



767

**ILLUSTRATED TOOL AND EQUIPMENT MANUAL**

**PART NUMBER: A54007-15**

**NAME:** SLING - DIAGONAL BRACE UNLOAD/RB211-524 ENGINE

**AIRPLANE MAINTENANCE:** YES

**COMPONENT MAINTENANCE:** NO

**USAGE & DESCRIPTION:** A54007-15 sling is used on 767-300 and 300ER airplanes equipped with RB211-524 engines. A54007 is used to apply a force to the strut so that the diagonal brace can be removed or installed. Refer to AMM 54-51-01, AMM 54-51-02, AMM 54-51-04 and AMM 54-51-05 for complete usage instructions. A54007-15 consists of an A54007-2 sling assembly, an A-342-3/4 link, both contained in a storage box.

**WEIGHT:** 35 lbs (16 kg)

**DIMENSIONS:** 12 x 18 x 36 inches (305 x 457 x 914 mm)

**NOTE:** A54007-15 supersedes A54007-1.  
J54001 replaces A54007 for future procurement for 767 Rolls-Royce engines.

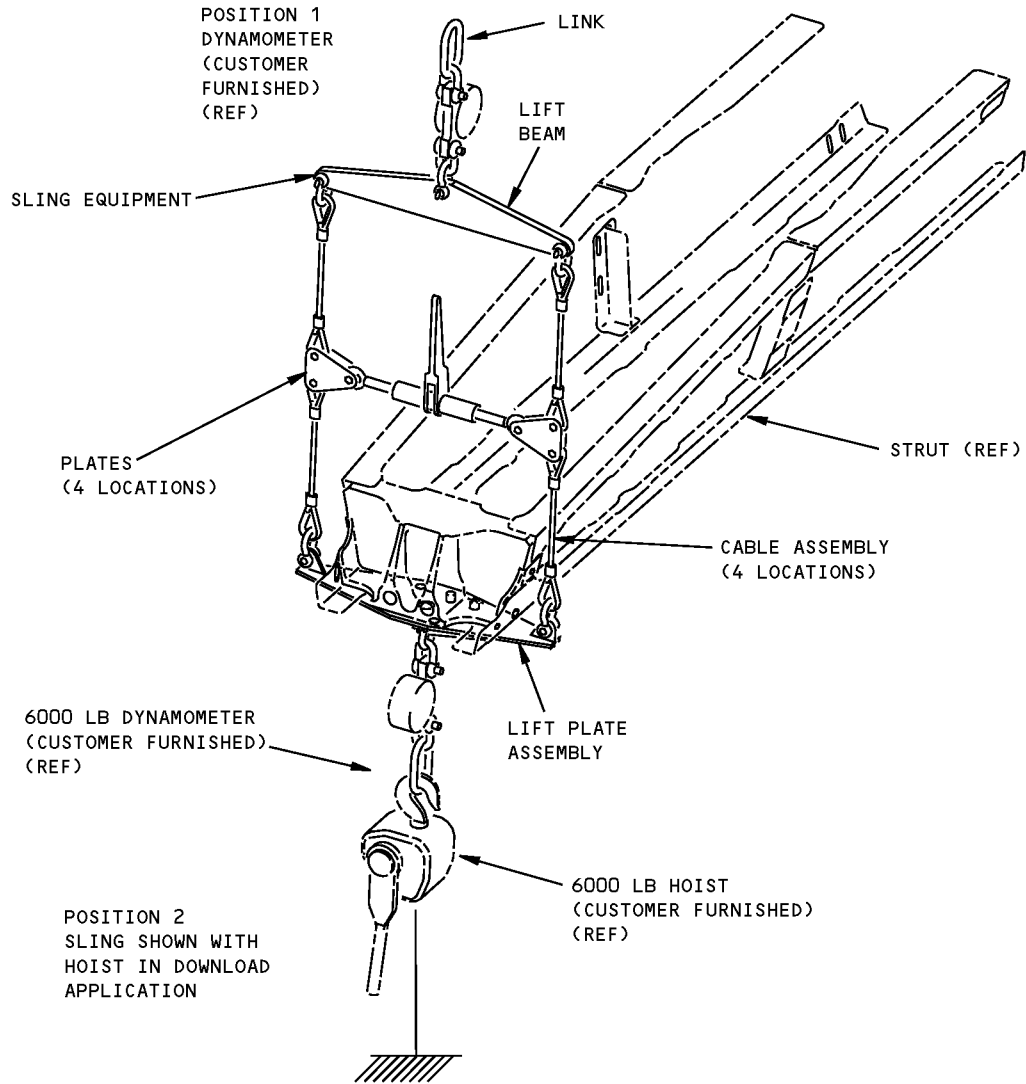

**Diagonal Brace Unload/RB211-524 Engine Sling**  
**Figure 1**

## ILLUSTRATED TOOL AND EQUIPMENT MANUAL

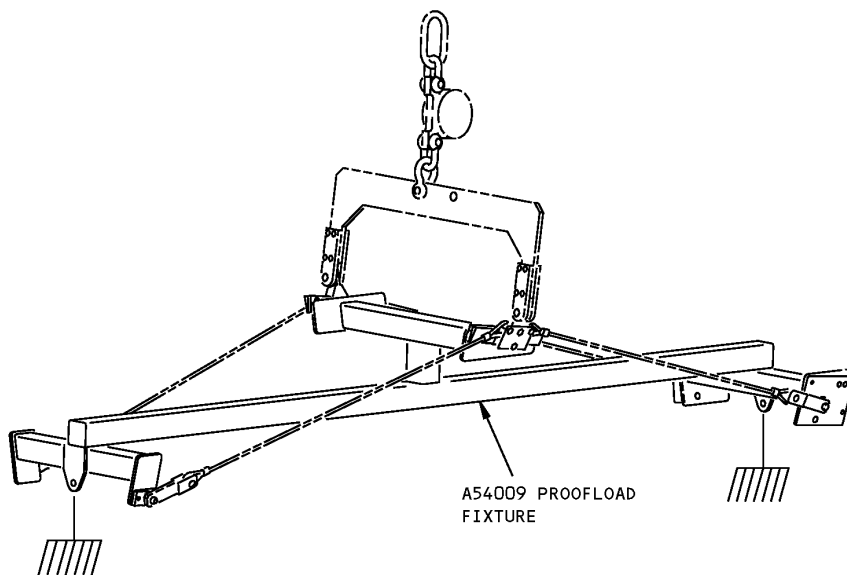
**PART NUMBER: A54009-1****NAME:** PROOFLOAD FIXTURE RB211-524H STRUT SLING**AIRPLANE MAINTENANCE:** YES**COMPONENT MAINTENANCE:** NO**USAGE & DESCRIPTION:** The A54009-1 proof load fixture is used to proof load the RB211-524H strut sling, which is used on 767 airplanes equipped with RB211-524H engines. A54009-1 is comprised of a main, support, forward, aft and upper beams and forward, aft, mid and end plate.**WEIGHT:** 110 lbs (50 kg)**DIMENSIONS:** 18 x 28 x 69 inches (305 x 711 x 1753 mm)

**RB211-524H Strut Sling Proofload Fixture**  
**Figure 1**

## ILLUSTRATED TOOL AND EQUIPMENT MANUAL

**PART NUMBER: B54016-1****NAME:** REMOVAL TOOL - SPLIT BUSHING**AIRPLANE MAINTENANCE:** YES**COMPONENT MAINTENANCE:** NO

**USAGE & DESCRIPTION:** The B54016-1 removal tool is used on 767 airplanes equipped with CF6-80A engines only. B54016 is used to remove bushings that have migrated in the upper and lower spar fittings on nacelle strut structures. Refer to the current B54016 drawing and the Structural Repair Manual (SRM) 54-51-90 for complete usage instructions. B54016-1 consists of a B54016-2 bushing puller assembly, one each of B54016-5, B54016-6, B54016-7 and B54016-8 split washer assemblies, all contained in a storage box.

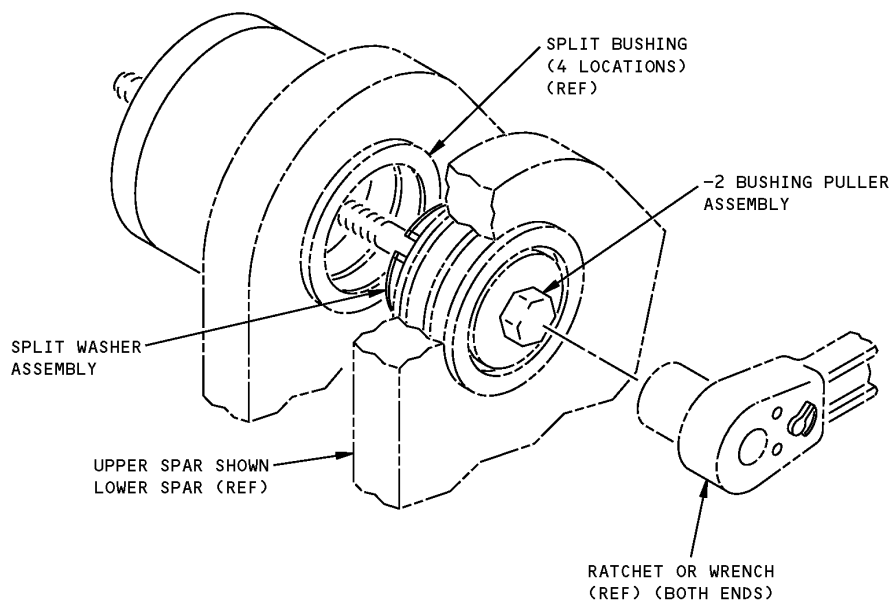
**WEIGHT:** 5 lbs (2.3 kg)**DIMENSIONS:** 3 x 5 x 8 inches (76 x 127 x 203 mm)

**Split Bushing Removal Tool  
Figure 1**



767

## ILLUSTRATED TOOL AND EQUIPMENT MANUAL

**PART NUMBER: A54011-18, -24, -25, -26**

**NAME:** REMOVAL/INSTALLATION KIT - MIDSPAR FUSE PIN

**AIRPLANE MAINTENANCE:** YES

**COMPONENT MAINTENANCE:** NO

**USAGE & DESCRIPTION:** The A54011-18, -24 or -25 removal/installation kits are used on 767-200 and -300 airplanes. The A54011-26 removal/installation kit is used on 767-400 airplanes only.

The A54011 removal/installation kits are used to remove or install the midspar fuse pins. Refer to AMM 54-51-05 for complete usage instructions.

The A54011-18 removal/installation kit is used with fuse pins part numbers 311T2102 and 311T3102 (pre-PRRB12699). The A54011-18 removal/installation kit is not recommended for future procurement. The A54011-18 removal/installation kit can be modified to become an A54011-25 removal/installation kit by adding the A54011-21 puller assembly.

A54011-24 removal/installation kit is used with fuse pin part number 310T2301 only (post-PRRB12699).

A54011-25 removal/installation kit contains the A54011-19 and -21 puller assemblies. The A54011-25 removal/installation kit can be created from either the A54011-18 or -24 removal/installation kit by adding the missing puller assembly. The A54011-25 removal/installation kit is used with fuse pin part numbers 311T2102, 311T3102 and 310T2301.

The A54011-18, -24, -25, and -26 removal/ installation kits consists of:

A54011-18		
QUANTITY	NOMENCLATURE	PART NUMBER
1	PULLER ASSEMBLY	A54011-19
1	SLUG AND NUT ASSEMBLY	A54011-3
1	SLIDE SCREW	CG240-8
1	SLIDE HAMMER	CG240-9
1	WRENCH ASSEMBLY	A54011-14
1	STORAGE BOX	

A54011-24		
QUANTITY	NOMENCLATURE	PART NUMBER
1	SLUG AND NUT ASSEMBLY	A54011-3
1	SLIDE SCREW	CG240-8



767

ILLUSTRATED TOOL AND EQUIPMENT MANUAL

A54011-24		
QUANTITY	NOMENCLATURE	PART NUMBER
1	SLIDE HAMMER	CG240-9
1	WRENCH ASSEMBLY	A54011-14
1	PULLER ASSEMBLY	A54011-21
1	STORAGE BOX	

A54011-25		
QUANTITY	NOMENCLATURE	PART NUMBER
1	PULLER ASSEMBLY	A54011-19
1	SLUG AND NUT ASSEMBLY	A54011-3
1	SLIDE SCREW	CG240-8
1	SLIDE HAMMER	CG240-9
1	WRENCH ASSEMBLY	A54011-14
1	PULLER ASSEMBLY	A54011-21
1	STORAGE BOX	

A54011-26		
QUANTITY	NOMENCLATURE	PART NUMBER
1	PULLER ASSEMBLY	A54011-27
1	SLUG AND NUT ASSEMBLY	A54011-28
1	SLIDE SCREW	CG240-8
1	SLIDE HAMMER	CG240-9
1	STORAGE BOX	

**WEIGHT:** 5 lbs (2.3 kg)

**DIMENSIONS:** 3 x 8 x 21 inches (76 x 203 x 533 mm)

**NOTE:** A54011-18 supersedes A54011-13.  
A54011 replaces A54008 for future procurement.



**767  
ILLUSTRATED TOOL AND EQUIPMENT MANUAL**

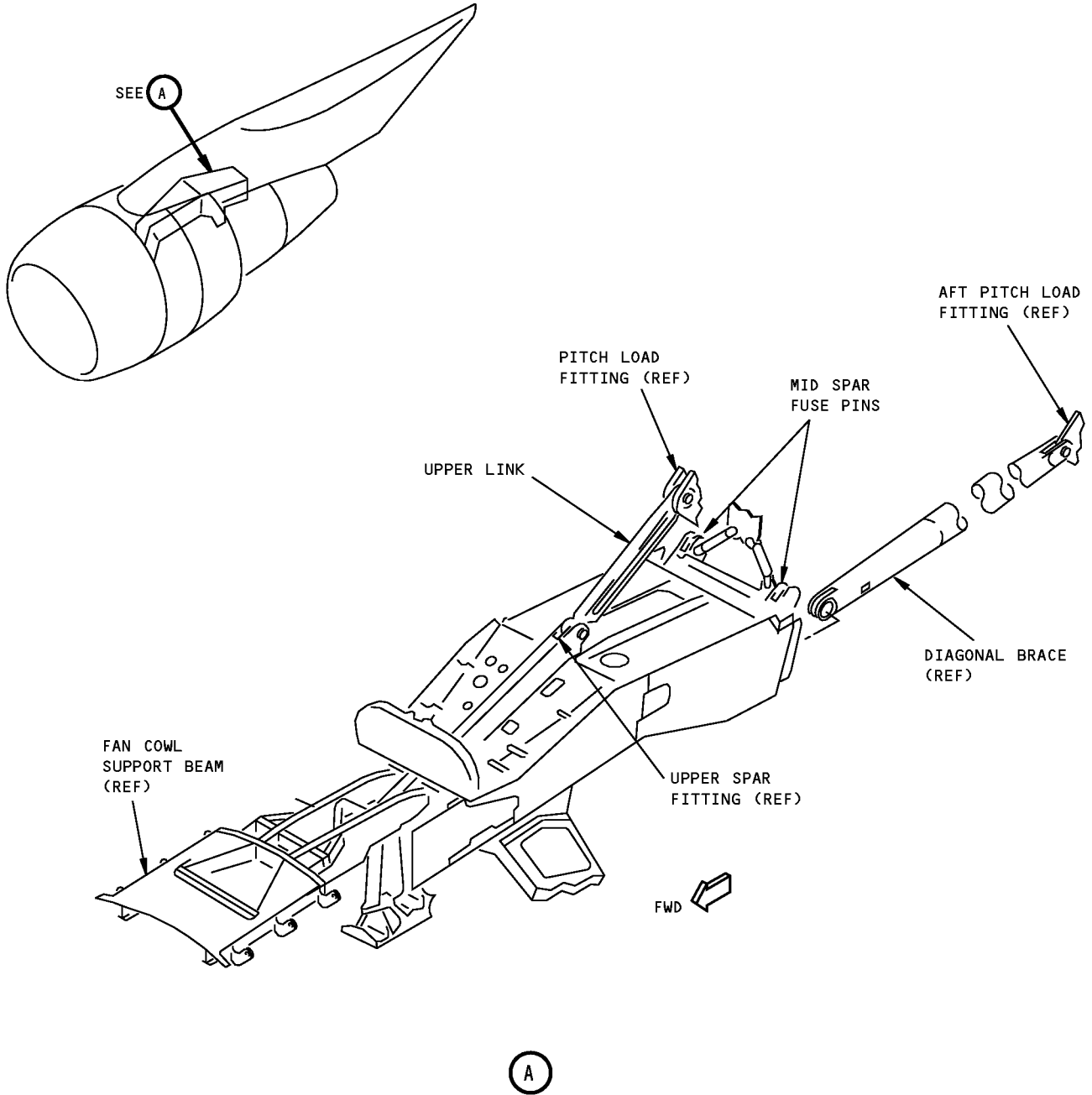

**Mid Spar Fuse Pin Location  
Figure 1**

**ILLUSTRATED TOOL AND EQUIPMENT MANUAL**

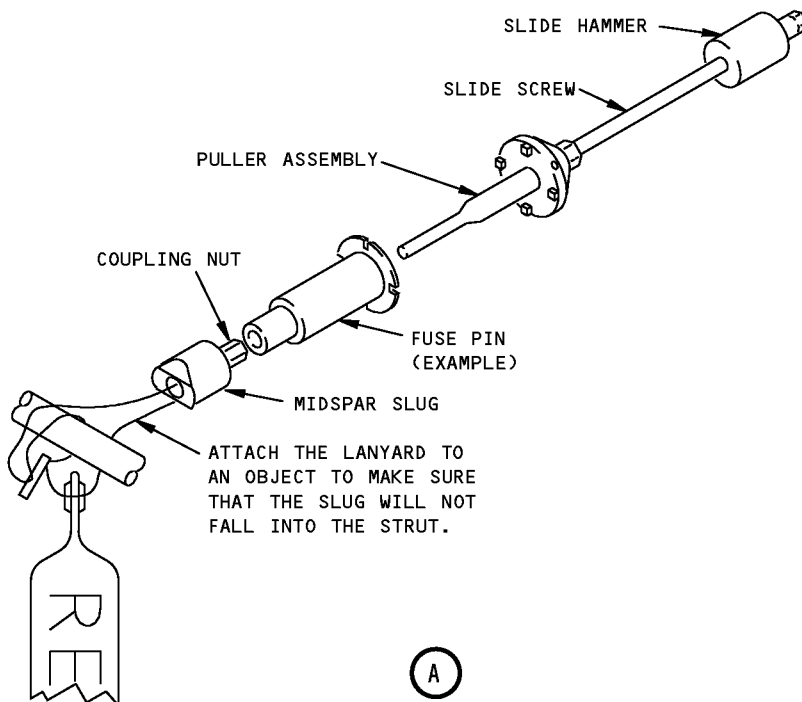
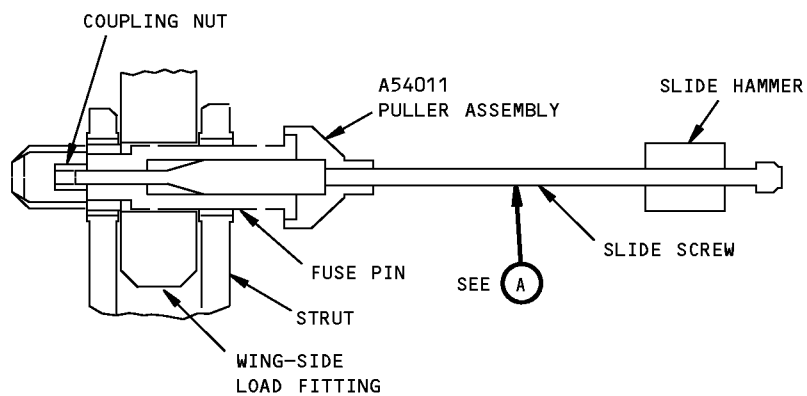

**Midspar Fuse Pin Removal/Installation Kit  
Figure 2**



767

## ILLUSTRATED TOOL AND EQUIPMENT MANUAL

**PART NUMBER: G54007-82, -91, -93, -165**

**NAME:** STRUT SLING - PRELOAD/UNLOAD, DIAGONAL BRACE

**AIRPLANE MAINTENANCE:** YES

**COMPONENT MAINTENANCE:** NO

**USAGE & DESCRIPTION:** The G54007-165 strut sling assembly and the G54007-93 mount base plate assembly are used together on 767 airplanes equipped with CF6-80C engines. The G54007-165 strut sling assembly and the G54007-82 mount base plate assembly are used together on 767 airplanes equipped with CF6-80A engines. G54007-165 strut sling assembly and the G54007-91 mount base plate assembly are used together on 767 airplanes equipped with either PW4000 or JT9D-7R4 engines.

G54007 equipment is used to unload or preload the diagonal brace during pin replacement with the engine removed. Refer to AMM 54-51-01 and AMM 54-51-05 for complete usage instructions.

The G54007-165 strut sling assembly consists of a G54007-155 strut sling contained in a storage box.

The G54007-82 mount base plate assembly consists of a G54007-126 base plate assembly contained in a storage box.

The G54007-91 mount base plate assembly consists of a G54007-130 base plate assembly contained in a storage box.

The G54007-93 mount base plate assembly consists of a G54007-132 base plate assembly contained in a storage box.

**WEIGHT:** 110 lbs (50 kg)

**DIMENSIONS:** 20 x 36 x 42 inches (508 x 914 x 1067 mm)

**NOTE:** J54001 is optional to G54007 for 767 General Electric and Pratt and Whitney engine strut usage.  
G54007-165 and -93 are preferred for future procurement for use with CF6-80C engine struts.  
G54007-165 supersedes G54007-80.

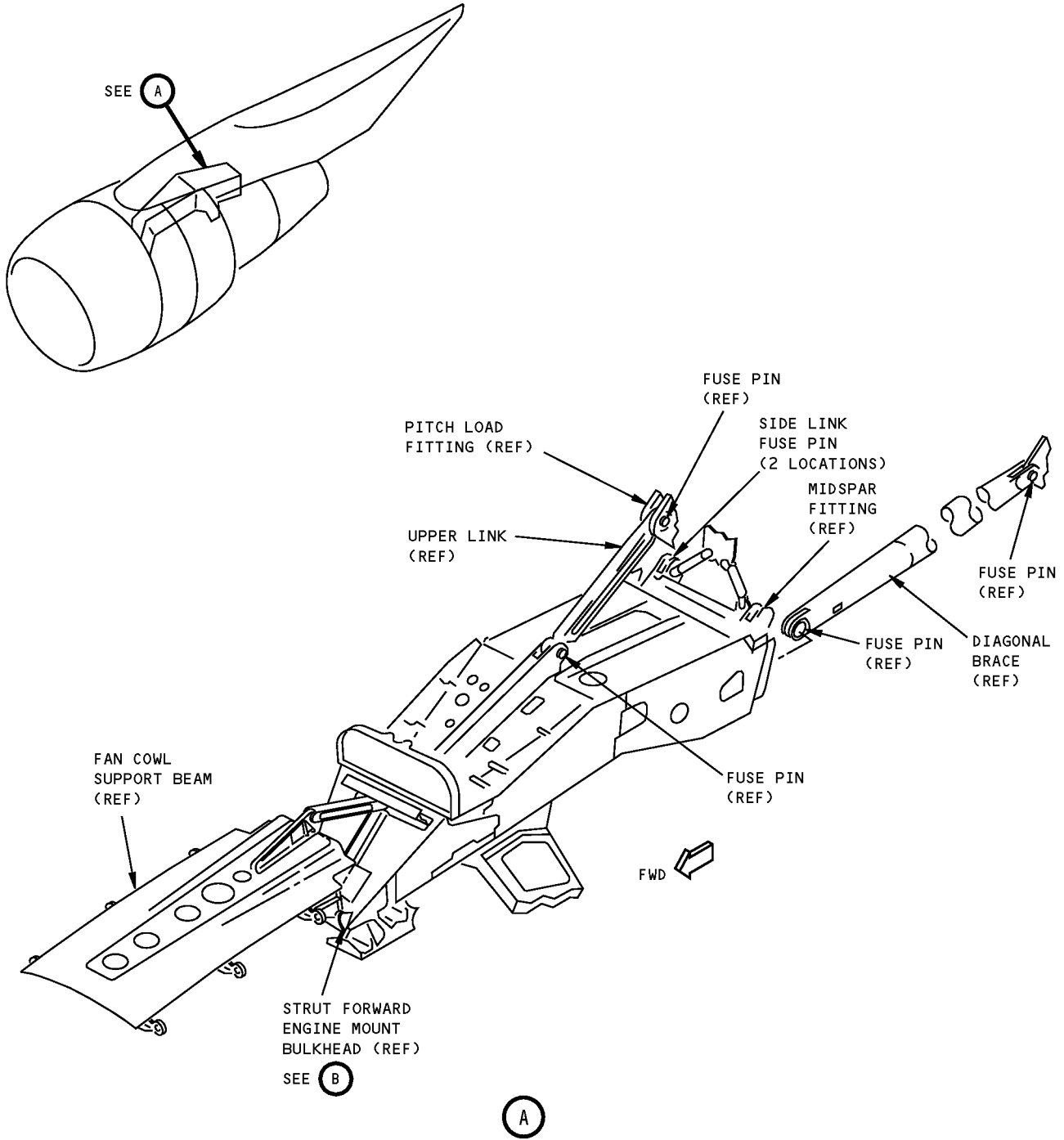

**Diagonal Brace Preload/Unload Strut Sling**  
**Figure 1 (Sheet 1 of 2)**

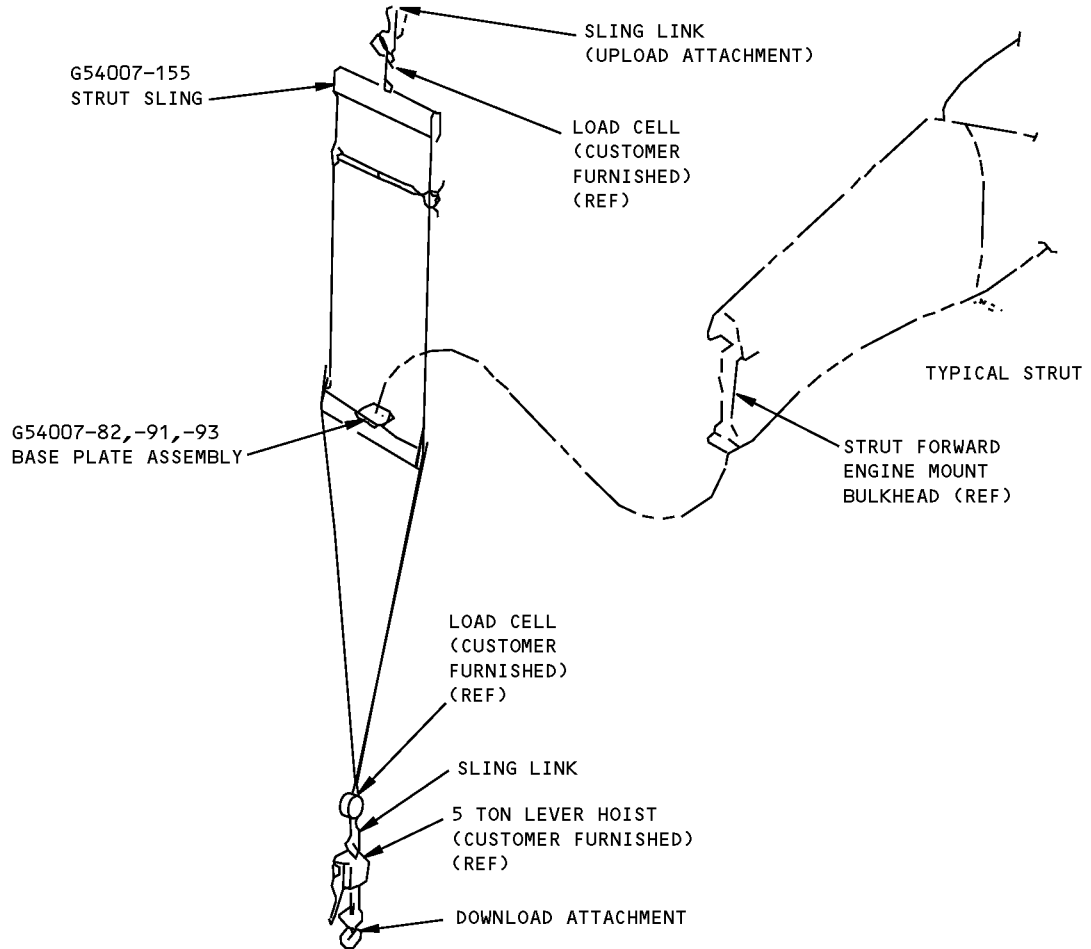

(B)

**Diagonal Brace Preload/Unload Strut Sling  
Figure 1 (Sheet 2 of 2)**



767

## ILLUSTRATED TOOL AND EQUIPMENT MANUAL

**PART NUMBER: J54001-73, -74, -75, -76**

**NAME:** STRUT UNLOAD SLING - DIAGONAL BRACE ALIGNMENT

**AIRPLANE MAINTENANCE:** YES

**COMPONENT MAINTENANCE:** NO

**USAGE & DESCRIPTION:** J54001-73 strut unload sling is used on all 767 airplanes. The J54001-74 base plate assembly is used in combination with the J54001-73 sling on 767 airplanes equipped with CF6-80C2 and CF6-80A engines. The J54001-75 base plate assembly is used in combination with the J54001-73 sling on 767 airplanes equipped with Pratt and Whitney PW4056 and JT9D-7R4 engines. The J54001-76 base plate assembly is used in combination with the J54001-73 sling on 767 airplanes equipped with Rolls Royce RB211 engines. The J54001 equipment is used to preload engine strut without the engine installed, during diagonal brace pin installation or removal. Refer to AMM 54-51-05 for complete usage instructions. The J54001-73 strut unload sling consists of a J54001-13 upper sling assembly, a J54001-18 lower beam assembly, a J54001-19 short cable assembly, a J54001-20 long cable assembly and the associated hardware. All of the J54001-73 sling equipment is contained in a sling storage box. The appropriate J54001 base plate for the engine configuration is contained in a base plate storage box.

**WEIGHT:** J54001-73 - 93 lbs (42 kg)  
J54001-74,-75,-76 - 12 lbs (5.4 kg)

**DIMENSIONS:** J54001-73 - 12 x 18 x 52 inches (305 x 457 x 1321 mm)  
J54001-74,-75,-76 - 4 x 8 x 12 inches (102 x 203 x 305 mm)

**NOTE:** G54007 is optional to J54001 for 767 General Electric and Pratt and Whitney usage.  
J54001 replaces A54007 for future procurement for 767 Rolls-Royce engines.  
J54001 or G54007 replaces A54004 for future procurement.

**ILLUSTRATED TOOL AND EQUIPMENT MANUAL**

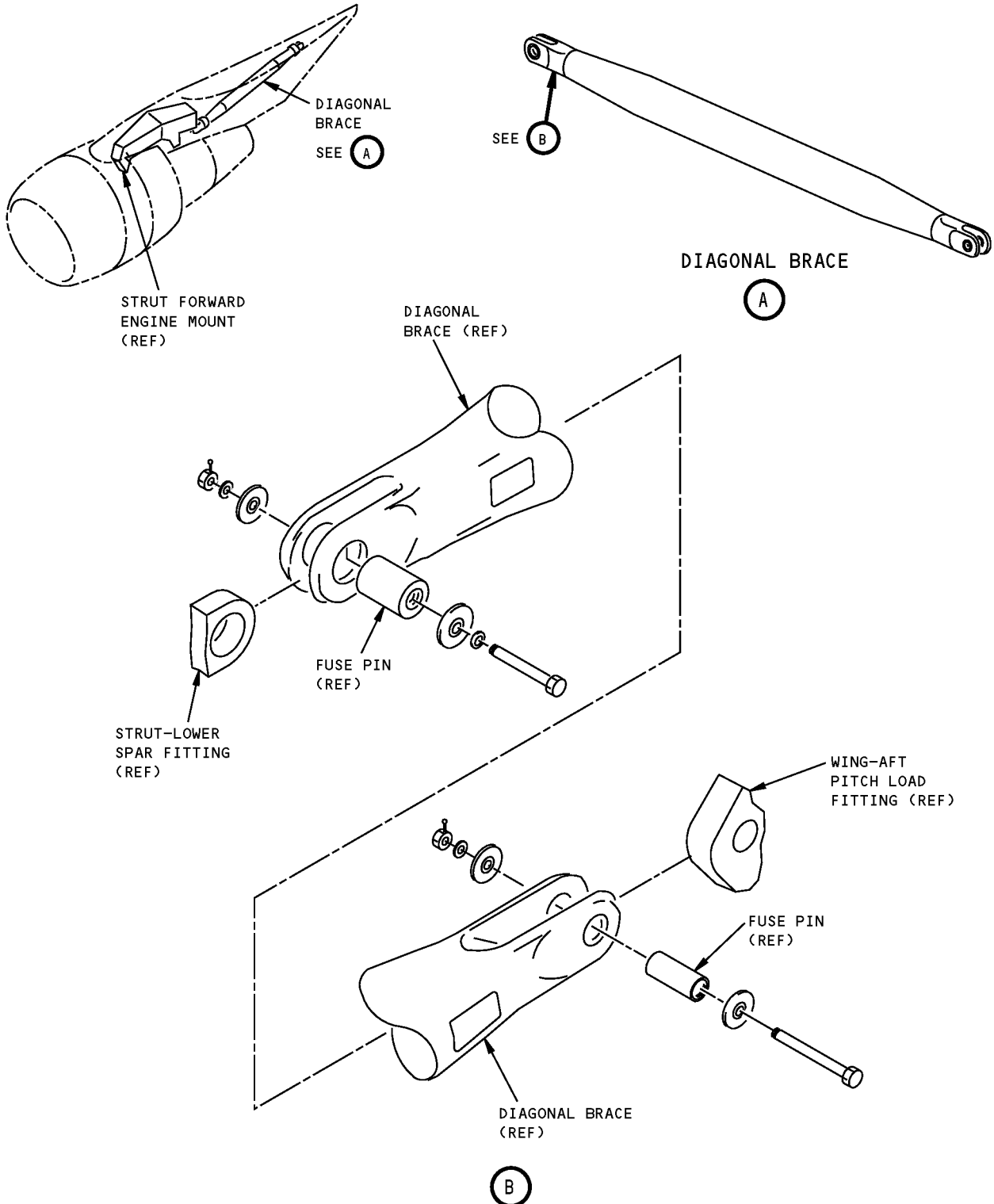

**Diagonal Brace Alignment Strut Unload Sling  
Figure 1 (Sheet 1 of 2)**

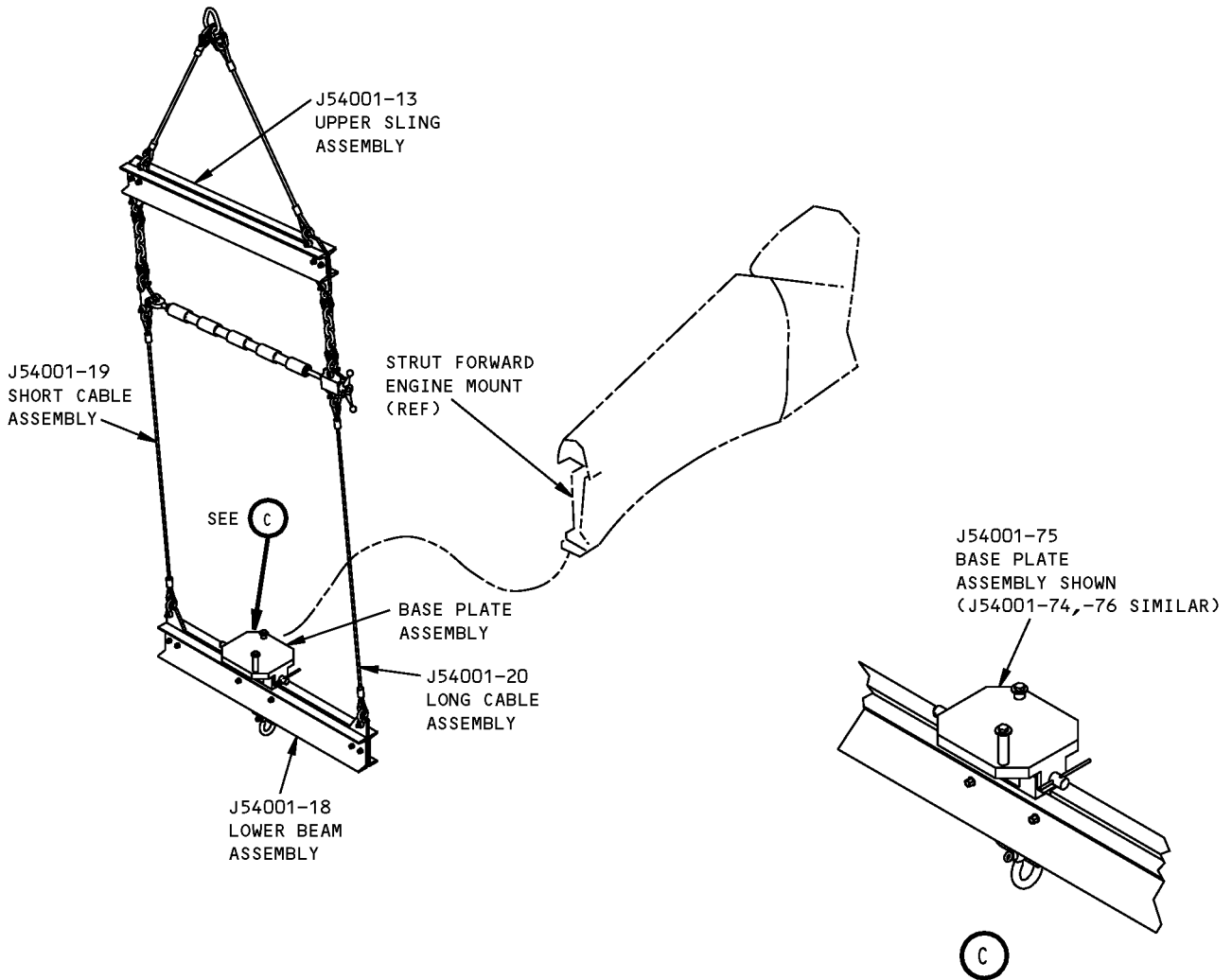

**Diagonal Brace Alignment Strut Unload Sling  
Figure 1 (Sheet 2 of 2)**