

CHAPTER

55

STABILIZER



767

ILLUSTRATED TOOL AND EQUIPMENT MANUAL

CHAPTER 55
STABILIZER

Subject/Page	Date	Subject/Page	Date	Subject/Page	Date
EFFECTIVE PAGES		55-30-02			
1	Apr 10/2008	1	Apr 10/2006		
2	BLANK	2	Apr 10/2007		
55-CONTENTS					
1	Oct 10/2007				
2	BLANK				
55-10-01					
1	Apr 10/2007				
2	Apr 10/2007				
3	Apr 10/2006				
4	Apr 10/2006				
5	Apr 10/2007				
6	Apr 10/2007				
55-10-02					
1	Oct 10/2007				
2	Apr 10/2006				
55-10-03					
1	Apr 10/2006				
2	Apr 10/2006				
3	Apr 10/2006				
4	Apr 10/2006				
55-10-04					
1	Apr 10/2007				
2	Apr 10/2007				
55-10-05					
1	Apr 10/2006				
2	Apr 10/2006				
55-10-06					
1	Apr 10/2006				
2	Apr 10/2006				
3	Apr 10/2006				
4	Apr 10/2006				
55-20-01					
1	Apr 10/2006				
2	Apr 10/2006				
55-30-01					
1	Apr 10/2007				
2	Apr 10/2007				
3	Apr 10/2007				
4	Apr 10/2007				

A = Added, R = Revised, O = Overflow, D = Deleted

55-EFFECTIVE PAGES



767

ILLUSTRATED TOOL AND EQUIPMENT MANUAL

TABLE OF CONTENTS

<u>Subject</u>	<u>Title</u>	<u>Part No.</u>
55-	STABILIZER	
55-10-01	LOCK EQUIPMENT - HORIZONTAL STABILIZER	A55001-19, -22, -42
55-10-02	REMOVAL EQUIPMENT - PIVOT BEARING, HORIZONTAL STABILIZER	A55005-1
55-10-03	JACKING EQUIPMENT - HINGE, HORIZONTAL STABILIZER	A55004-98
55-10-04	TEMPLATE - BLADE SEAL FITTING, HORIZONTAL STABILIZER	A55006-1
55-10-05	REMOVAL/INSTALLATION EQUIPMENT - PIVOT BEARING HORIZONTAL STABILIZER	A55007-1
55-10-06	REMOVAL/INSTALLATION EQUIPMENT - PIVOT BEARING, HORIZONTAL STABILIZER	A27114-1
55-20-01	ALIGNMENT EQUIPMENT - HINGE, INBOARD ELEVATOR	A55003-1
55-30-01	SLING - VERTICAL FIN INSTALLATION AND REMOVAL	A07007-33
55-30-02	TORQUE MULTIPLIER EQUIPMENT - TENSION BOLTS, VERTICAL FIN	A07006-1

55-CONTENTS

Page 1
Oct 10/2007

D634T501



767

ILLUSTRATED TOOL AND EQUIPMENT MANUAL

PART NUMBER: A55001-19, -22, -42

NAME: LOCK EQUIPMENT - HORIZONTAL STABILIZER

AIRPLANE MAINTENANCE: YES

COMPONENT MAINTENANCE: NO

USAGE & DESCRIPTION: The A55001-19, -22 lock equipment and A55001-42 test equipment is used on all 767 airplanes. A55001-19 or -22 lock equipment is used to secure the horizontal stabilizer during removal or installation of the stabilizer trim actuator. A55001-19 incorporates an A55001-13 fuse. Both A55001-22 and -42 incorporate an A55001-18 fuse handle. The fuse and fuse handles prevent damage to the airplane structure in the event power is applied to the stabilizer trim actuator with the A55001 lock or test equipment installed. A55001-19 is usable only when the stabilizer is in neutral position. A55001-19, -22, and -42 are designed as a turnbuckle arrangement and are adjustable for fine length adjustments. Both A55001-22 and -42 are usable with the stabilizer in any position. A55001-42 test equipment is similar in appearance and uses some common components of the A55001-19 or -22 but is used for checking free-play on the ballscrew of the horizontal stabilizer. A55001-42 also incorporates a push-pull force gauge required for doing the free-play checks. The A55001-19 test equipment can be reworked into the A55001-22 by using instructions on current A55001 drawing. The A55001-34 test equipment can be reworked into the A55001-42 test equipment by using instructions on current A55001 drawing. Refer to AMM 27-41-10 and current A55001 drawing for further usage instructions on the A55001-19 or -22 lock equipment and the A55001-42 test equipment. The A55001 equipment consists of:

A55001-19		
QUANTITY	NOMENCLATURE	PART NUMBER
1	LOCK ASSEMBLY	A55001-2
1	CLAMP FITTING	A55001-6
2	CLAMP ASSEMBLY	A55001-17
1	STORAGE BOX	

A55001-22		
QUANTITY	NOMENCLATURE	PART NUMBER
1	LOCK ASSEMBLY	A55001-23
1	CLAMP FITTING	A55001-6
2	CLAMP ASSEMBLY	A55001-17
1	STORAGE BOX	

767
ILLUSTRATED TOOL AND EQUIPMENT MANUAL

A55001-42		
QUANTITY	NOMENCLATURE	PART NUMBER
1	TEST ASSEMBLY	A55001-43
1	CLAMP FITTING	A55001-6
2	CLAMP ASSEMBLY	A55001-17
1	STORAGE BOX	

WEIGHT: 18 lbs (8.2 kg)

DIMENSIONS: 8 x 10 x 25 inches (203 x 254 x 635 mm)

NOTE: A55001-42 supersedes A55001-34.
A55001-22 replaces A55001-19 for future procurement.
A55001-19 supersedes A55001-1.

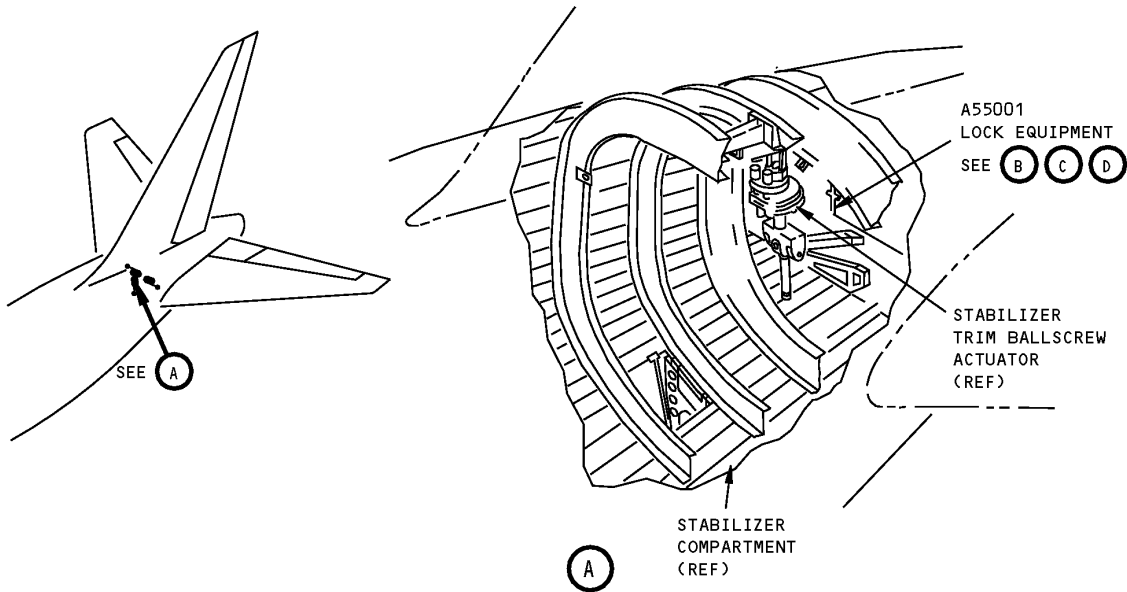

Horizontal Stabilizer Lock Equipment
Figure 1 (Sheet 1 of 4)

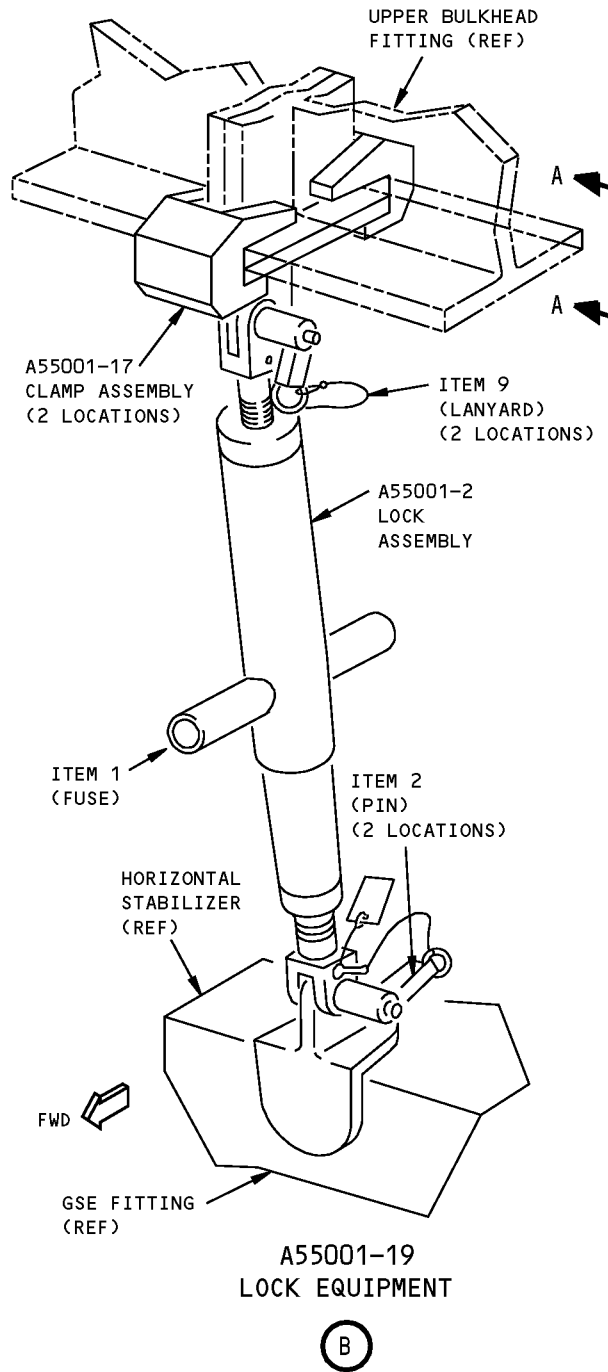

**Horizontal Stabilizer Lock Equipment
Figure 1 (Sheet 2 of 4)**

ILLUSTRATED TOOL AND EQUIPMENT MANUAL

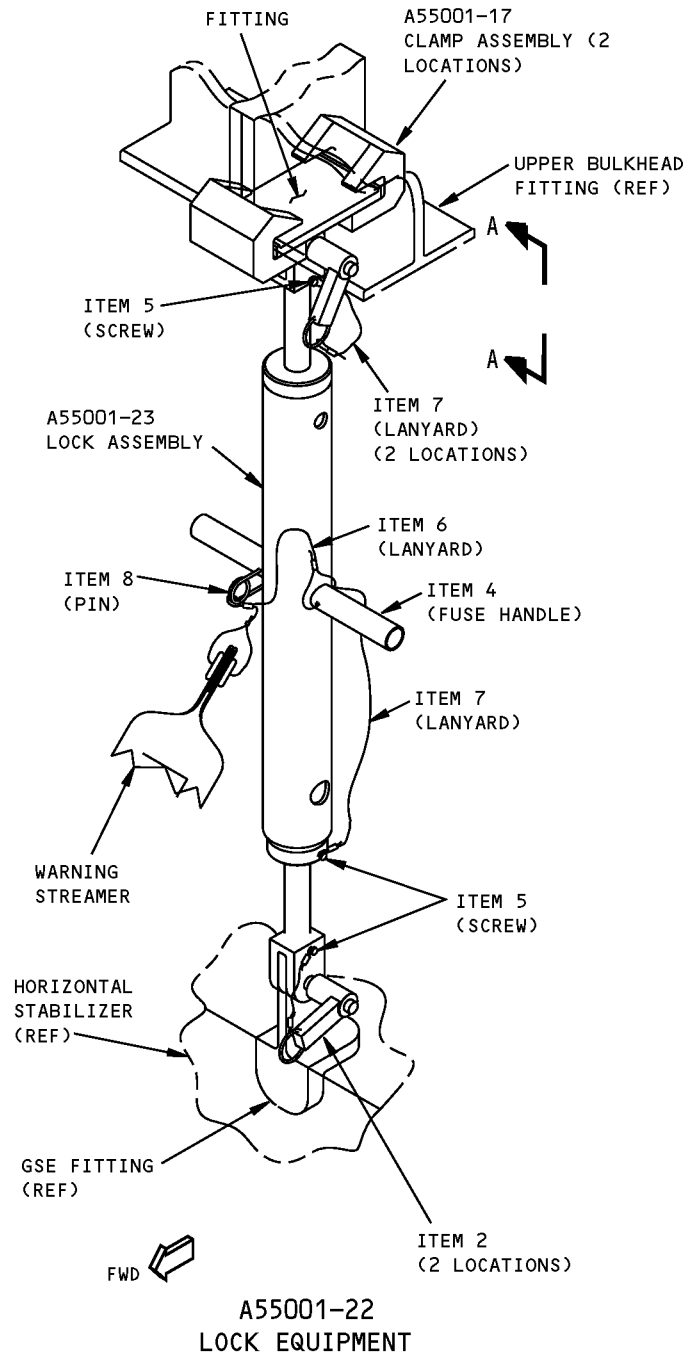

(C)

**Horizontal Stabilizer Lock Equipment
Figure 1 (Sheet 3 of 4)**

ILLUSTRATED TOOL AND EQUIPMENT MANUAL

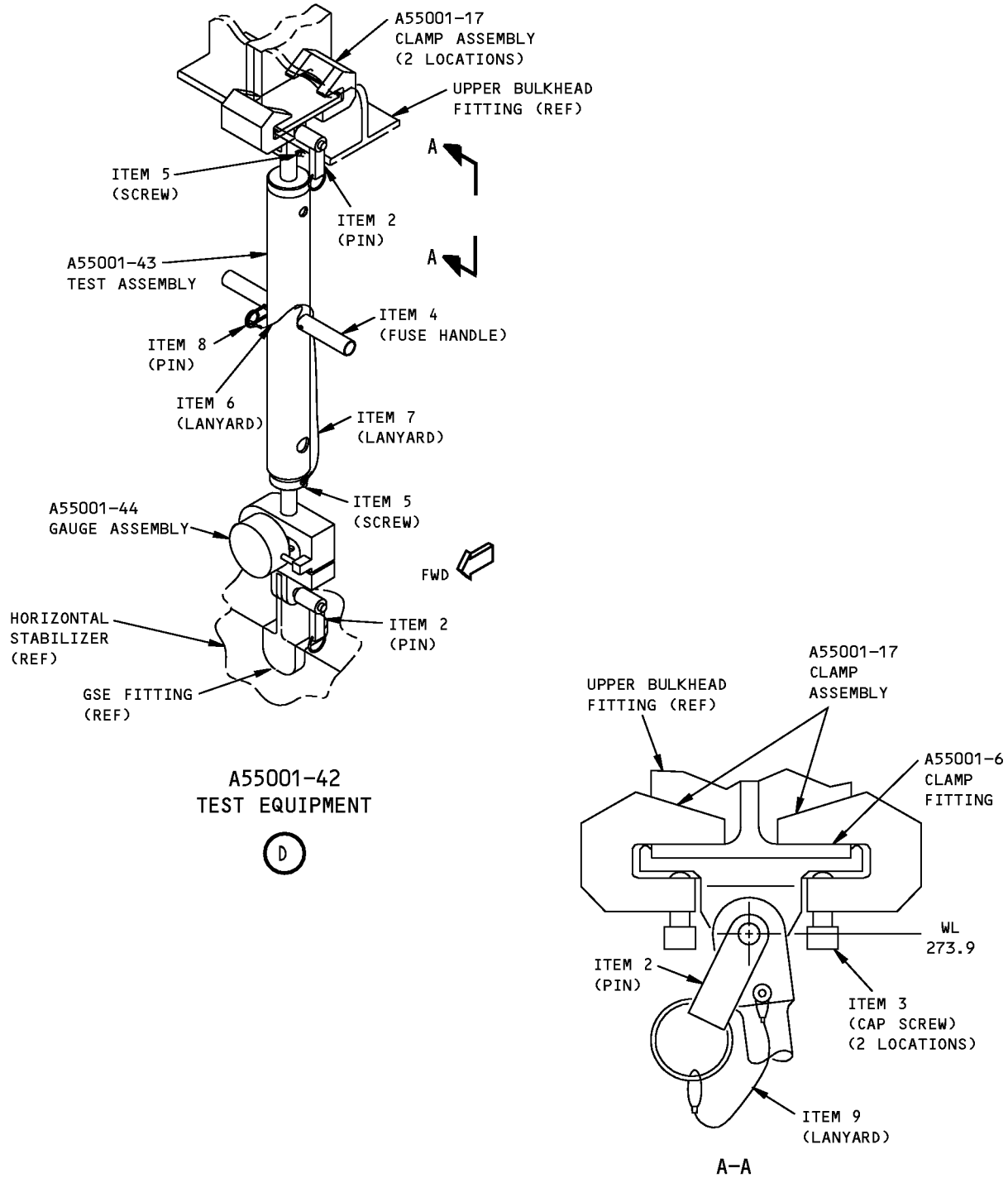

**Horizontal Stabilizer Lock Equipment
Figure 1 (Sheet 4 of 4)**



767

ILLUSTRATED TOOL AND EQUIPMENT MANUAL

REPAIRABLE/REPLACEABLE PARTS			
ITEM NO.	PART NO.	NOMENCLATURE	VENDOR CODE
1	A55001-13	FUSE	
2	NAS1337C5C12D	QUICK RELEASE PIN	
3	NAS1352-6-16P	CAP SCREW	
4	A55001-26	FUSE HANDLE	
5	NAS600-5	PAN HEAD SCREW	
6	CL-23-KA-6.0-LR	CABLE ASSEMBLY	V99862
7	CL-63-KA-15.0	CABLE ASSEMBLY	V99862
8	25-05	SAFETY PIN	V7V765
9	CL-62-KA-10.0	CABLE ASSEMBLY	V99862



767

ILLUSTRATED TOOL AND EQUIPMENT MANUAL

PART NUMBER: A55005-1

NAME: REMOVAL EQUIPMENT - PIVOT BEARING, HORIZONTAL STABILIZER

AIRPLANE MAINTENANCE: YES

COMPONENT MAINTENANCE: NO

USAGE & DESCRIPTION: The A55005-1 removal equipment is used on 767-200, -200ER, -300 and -300ER airplanes before line number 243 airplanes (V0197-V1000, V1026-V2000 and V2022-V5999). A55005 is used to remove the pivot bearings on the horizontal stabilizer. A55005 is used in conjunction with A32045-87 for removal of 180T0003 bearing - hinge support, A32045-48 for 182T1305 outboard nut, F70312-49 for 180T0010 nut - pivot and 180T0002 nut - inboard bearing, F70312-30 for 180T0010 nut-pivot and F70312-50 for 180T0012 trap fitting. Refer to AMM 55-17-51 for complete usage instructions. A55005-1 consists of an A55005-2 knurled screw assembly, an A55005-3 wrench, an A55005-6 washer, an A55005-7 rod and a CG253L puller, all contained in a storage box. .

WEIGHT: 7 lbs (3 kg)

DIMENSIONS: 6 x 6 x 14 inches (152 x 152 356 mm)

ILLUSTRATED TOOL AND EQUIPMENT MANUAL

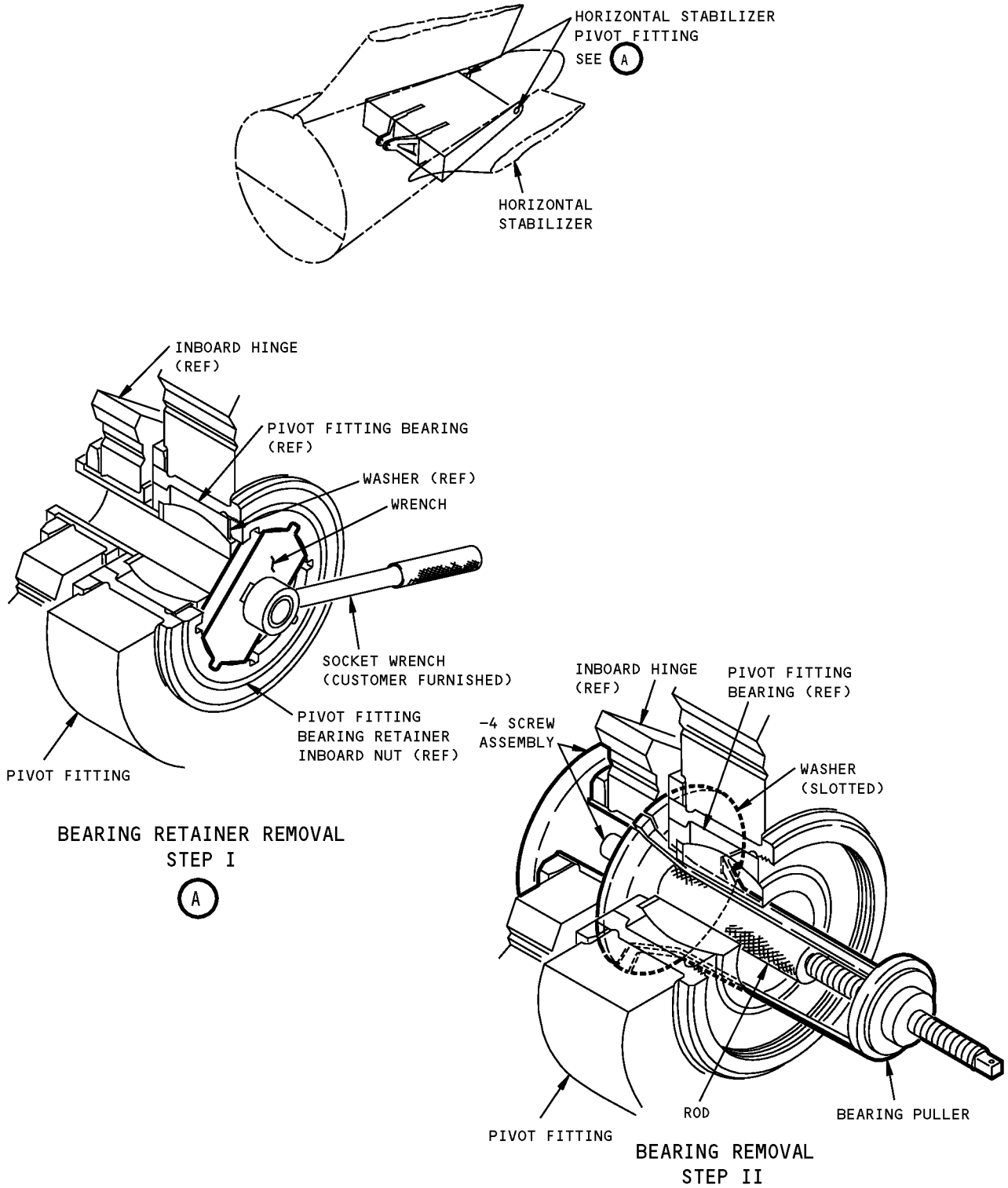

**Horizontal Stabilizer Pivot Bearing Removal Equipment
Figure 1**



767

ILLUSTRATED TOOL AND EQUIPMENT MANUAL

PART NUMBER: A55004-98

NAME: JACKING EQUIPMENT - HINGE, HORIZONTAL STABILIZER

AIRPLANE MAINTENANCE: YES

COMPONENT MAINTENANCE: NO

USAGE & DESCRIPTION: The A55004-98 jacking equipment is used on all 767 airplanes. A55004 is used to check hinge free play in horizontal stabilizer pivot pins, and to support the pivot fitting while a pivot pin is being adjusted or replaced. Refer to AMM 55-17-51 for complete usage instructions. A55004-98 consists of:

A55004-98		
QUANTITY	NOMENCLATURE	PART NUMBER
1	LEFT HAND BEAM ASSEMBLY	A55004-74
1	RIGHT HAND BEAM ASSEMBLY	A55004-75
1	SMALL TURNBUCKLE ASSEMBLY	A55004-5
1	LARGE TURNBUCKLE ASSEMBLY	A55004-84
1	CLAMP ASSEMBLY	A55004-85
1	CLAMP ASSEMBLY	A55004-86
1	HYDRAULIC ASSEMBLY	A55004-96
1	WASHER	AN960-616
1	CAP SCREW	MS16996-39
1	STORAGE BOX	

WEIGHT: 65 lbs (29 kg)

DIMENSIONS: 6 x 20 x 26 inches (152 x 508 x 660 mm)

NOTE: A55004-98 supersedes A55004-95.

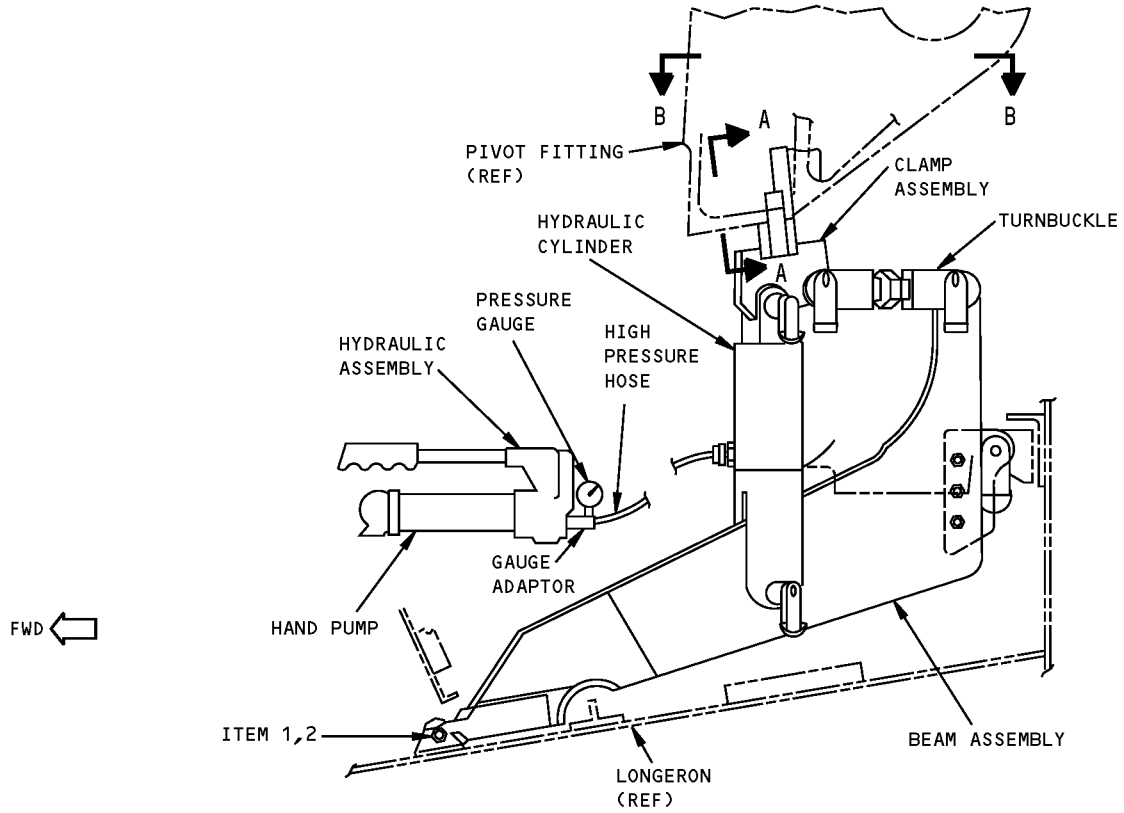

Horizontal Stabilizer Hinge Jacking Equipment
Figure 1 (Sheet 1 of 2)

ILLUSTRATED TOOL AND EQUIPMENT MANUAL

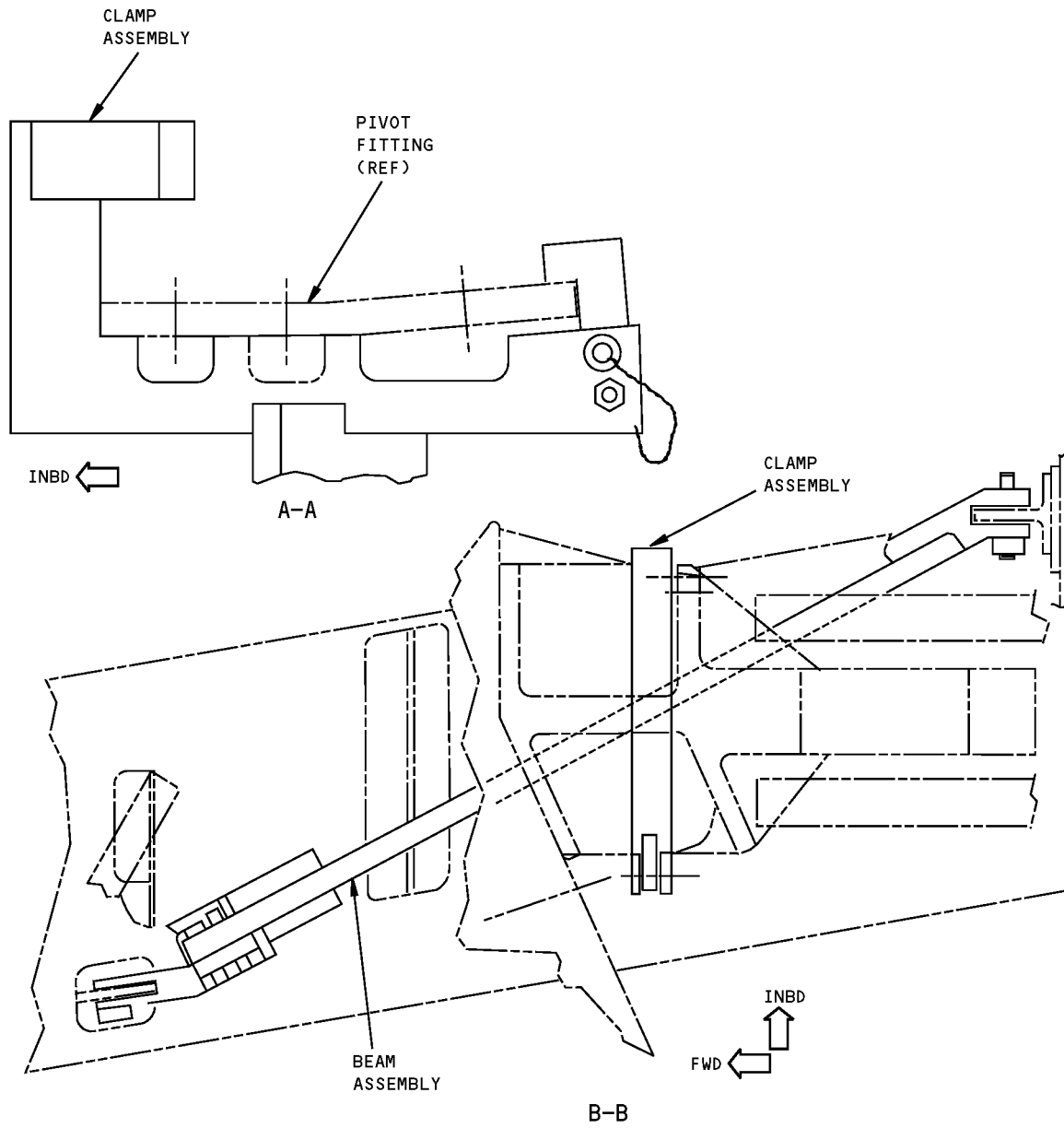

**Horizontal Stabilizer Hinge Jacking Equipment
Figure 1 (Sheet 2 of 2)**



767

ILLUSTRATED TOOL AND EQUIPMENT MANUAL

REPAIRABLE/REPLACEABLE PARTS			
ITEM NO.	PART NO.	NOMENCLATURE	VENDOR CODE
1	AN960-416	WASHER	
2	MS16996-39	CAP SCREW	

ILLUSTRATED TOOL AND EQUIPMENT MANUAL

PART NUMBER: A55006-1

NAME: TEMPLATE - BLADE SEAL FITTING, HORIZONTAL STABILIZER

AIRPLANE MAINTENANCE: YES

COMPONENT MAINTENANCE: NO

USAGE & DESCRIPTION: The A55006-1 template is used on 767-200, -200ER, -300 and -300ER airplanes with rubber horizontal stabilizer seals only. A55006 is used to gage the horizontal stabilizer blade seals during installation. Refer to AMM 55-10-02 for complete usage instructions. A55006-1 consists of a A55006-2 template contained in a storage box.

WEIGHT: 1 lb (0.4 kg)

DIMENSIONS: 0.2 x 2 x 3 inches (5 x 51 x 76 mm)

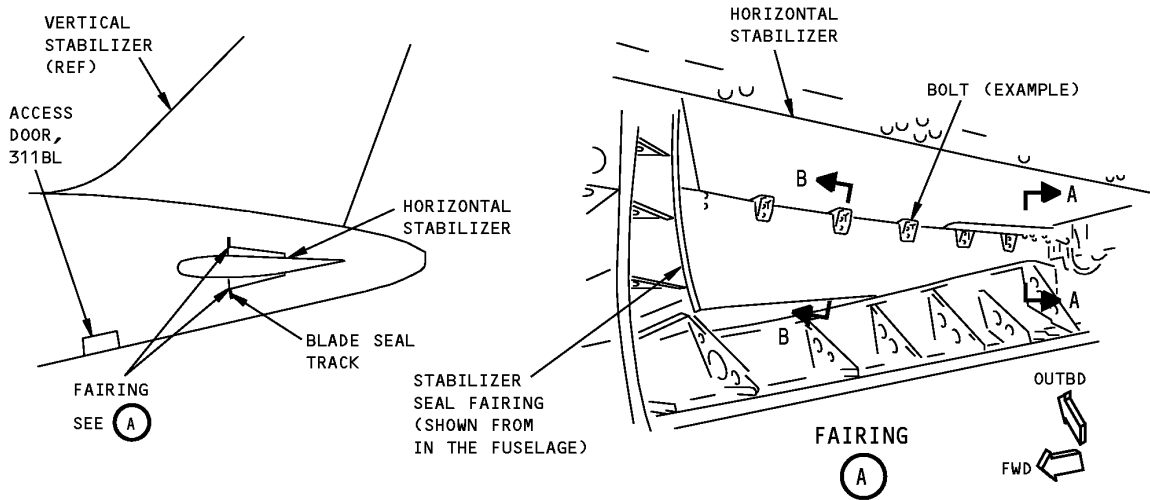

**Horizontal Stabilizer Blade Seal Location
Figure 1**

ILLUSTRATED TOOL AND EQUIPMENT MANUAL

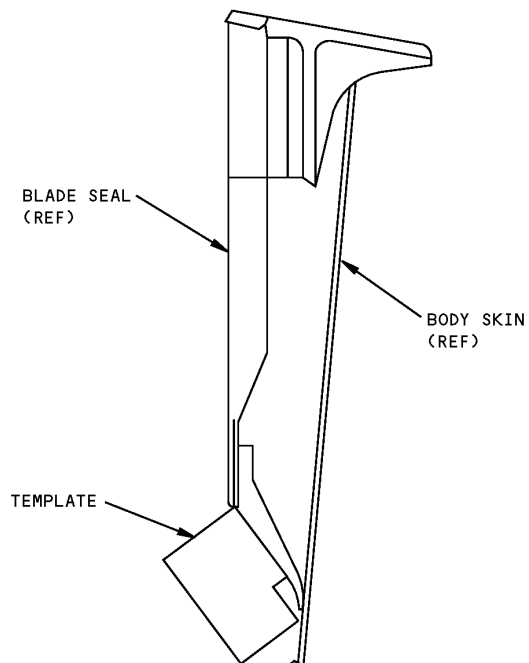

**Horizontal Stabilizer Template Blade Seal Fitting Template
Figure 2**



767

ILLUSTRATED TOOL AND EQUIPMENT MANUAL

PART NUMBER: A55007-1

NAME: REMOVAL/INSTALLATION EQUIPMENT - PIVOT BEARING HORIZONTAL STABILIZER

AIRPLANE MAINTENANCE: YES

COMPONENT MAINTENANCE: NO

USAGE & DESCRIPTION: The A55007-1 removal/installation equipment is used on 767 airplane effectivities V0197-V1000, V1026-V2000 and V2022-V5999 (line number 243 and on). A55007 is used to remove/install pivot bearings on horizontal stabilizer. A55007 is used in conjunction with A32045-87 for removal of 180T0003 bearing - hinge support, A32045-48 for 182T1305 outboard nut, F70312-49 for 180T0010 nut-pivot and 180T0002 nut - inboard bearing, F70312-30 for 180T0010 nut-pivot and F70312-50 for 180T0012 trap fitting. Refer to AMM 55-17-51 for complete usage instructions. A55007-1 consists of an A55007-2 installation assembly, an A55007-3 removal assembly, both contained in a storage box.

WEIGHT: 57 lbs (26 kg)

DIMENSIONS: 6 x 10 x 56 inches (152 x 254 x 1422 mm)

NOTE: A27114 replaces A55007 for future procurement.

**767
ILLUSTRATED TOOL AND EQUIPMENT MANUAL**

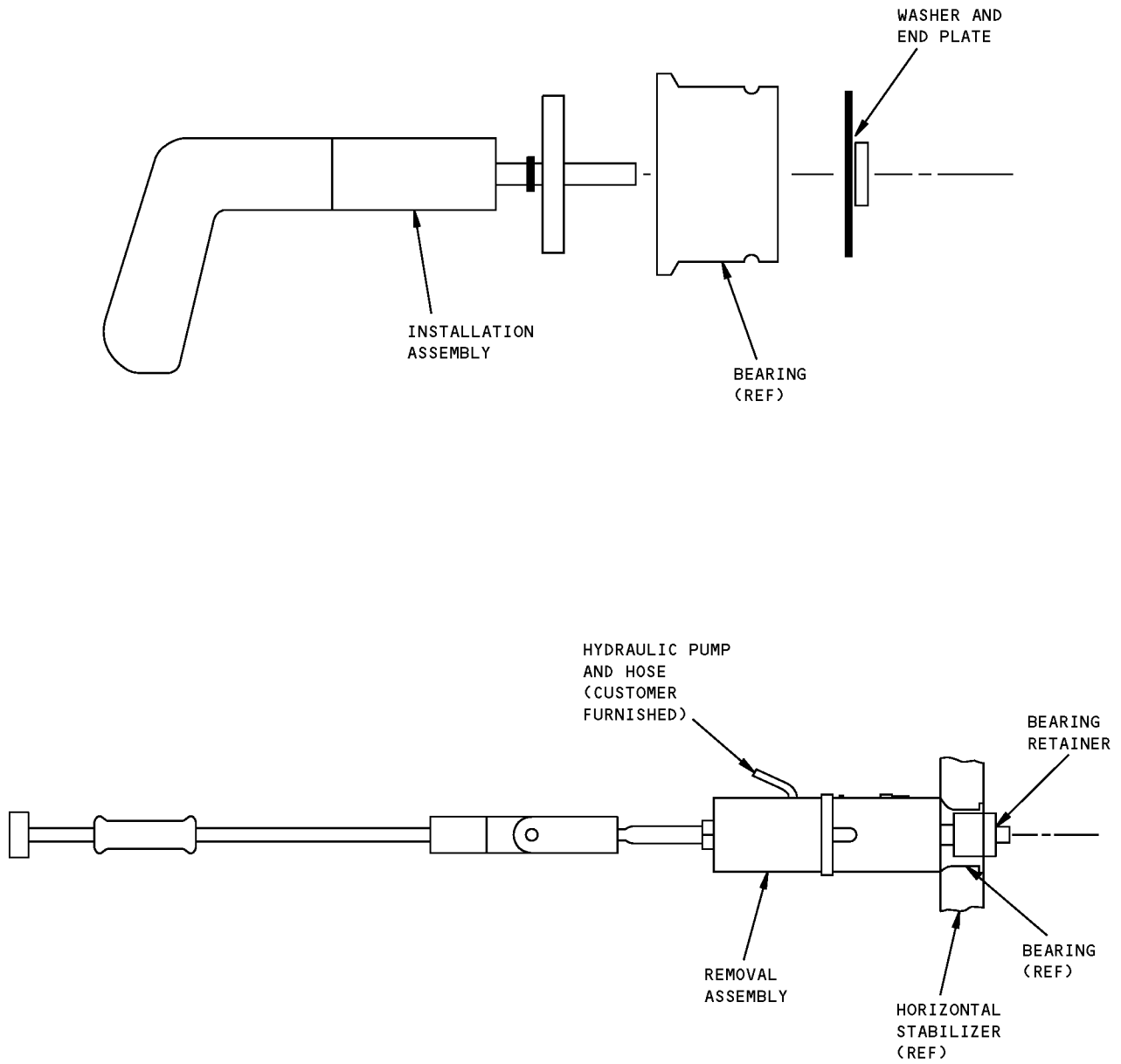

**Pivot Bearing Horizontal Stabilizer Removal/Installation Equipment
Figure 1**



767

ILLUSTRATED TOOL AND EQUIPMENT MANUAL

PART NUMBER: A27114-1

NAME: REMOVAL/INSTALLATION EQUIPMENT - PIVOT BEARING, HORIZONTAL STABILIZER

AIRPLANE MAINTENANCE: YES

COMPONENT MAINTENANCE: NO

USAGE & DESCRIPTION: The A27114-1 removal/installation equipment is used on all 767 airplanes. A27114 is used to remove or install the pivot bearing on horizontal stabilizer. Refer to AMM 55-17-51 for complete usage instructions. A27114-1 consists of:

A27114-1		
QUANTITY	NOMENCLATURE	PART NUMBER
1	INSTALLATION PLUG ASSEMBLY	A27114-2
1	SPANNER WRENCH ASSEMBLY BEARING	A27114-3
1	ALIGNMENT TOOL	A27114-4
1	BEARING PLUG	A27114-5
1	HOLDING PLATE	A27114-6
1	THREADED ROD	A27114-7
1	REMOVAL PLUG	A27114-8
1	SPANNER WRENCH RETAINER	A27114-9
1	BACKUP PLATE	A27114-10
2	SPHERICAL NUT/WASHER	CL-7-SNW
2	SCREW NUT	CL-16-JN
2	SCREW	CL-1/4-20 x 2.5 SHCS
1	CYLINDER AND PUMP SET	SCH-202H
1	STORAGE BOX	

WEIGHT: 75 lbs (34 kg)

DIMENSIONS: 6 x 10 x 56 inches (152 x 254 x 1422 mm)

ILLUSTRATED TOOL AND EQUIPMENT MANUAL

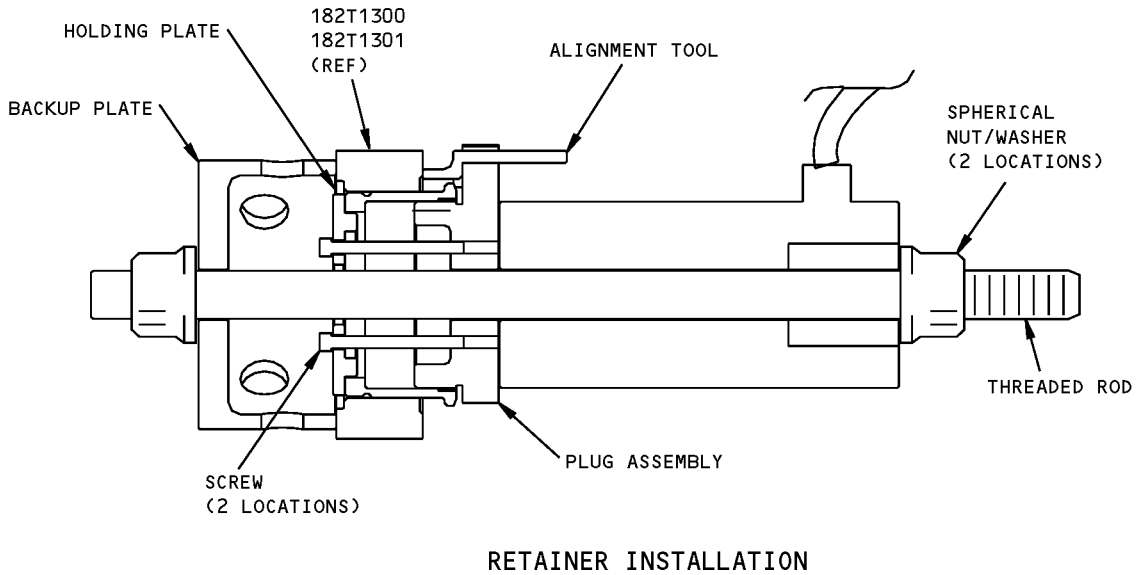
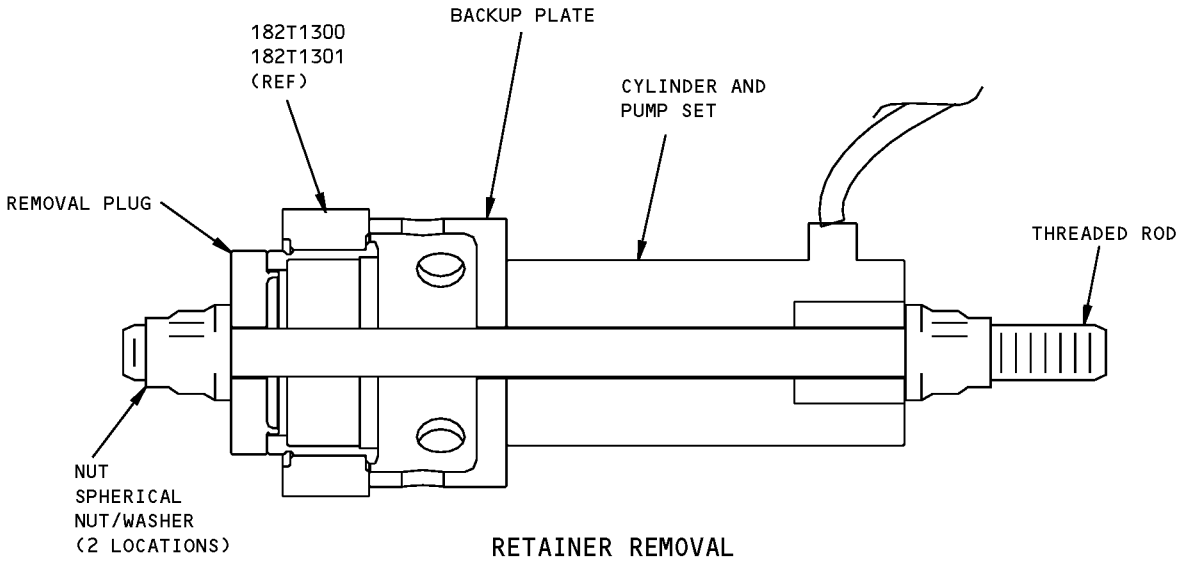

**Horizontal Stabilizer Pivot Bearing Removal/Installation Equipment
Figure 1 (Sheet 1 of 3)**

ILLUSTRATED TOOL AND EQUIPMENT MANUAL

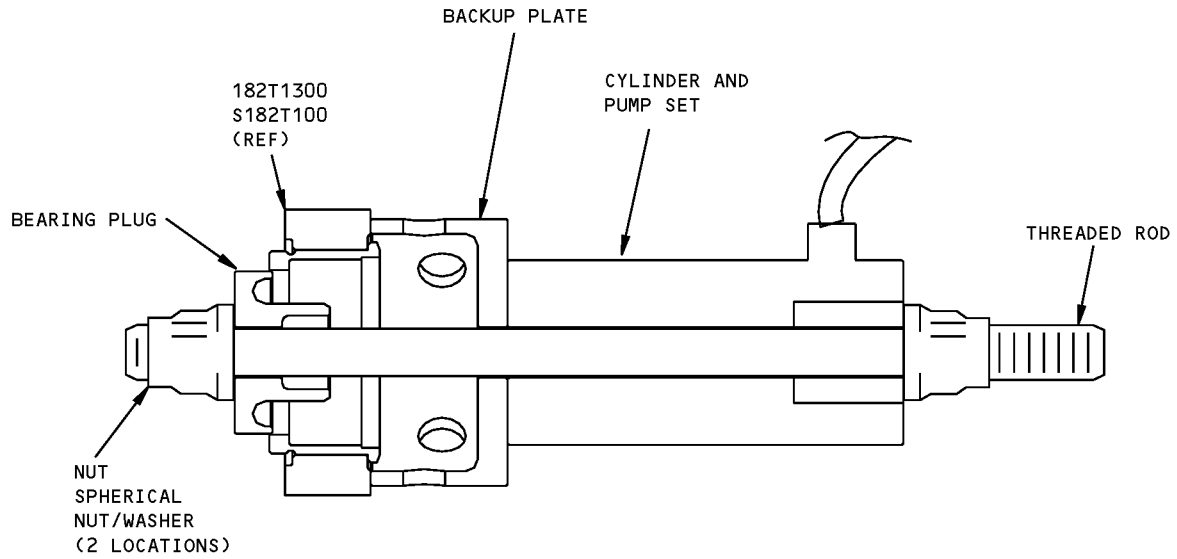

BEARING REMOVAL

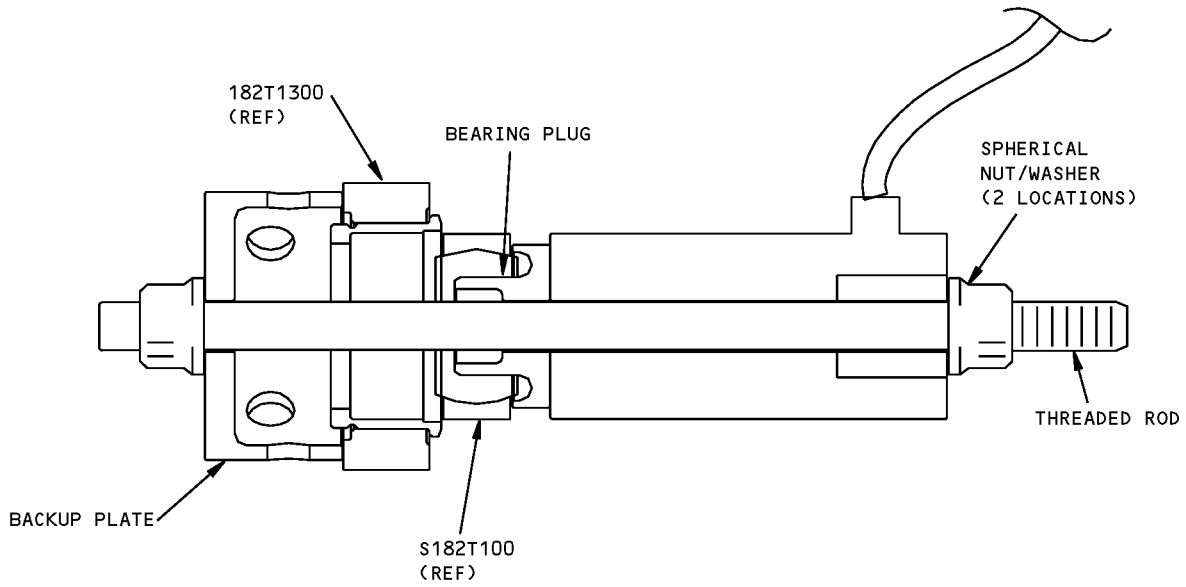

BEARING INSTALLATION

**Horizontal Stabilizer Pivot Bearing Removal/Installation Equipment
Figure 1 (Sheet 2 of 3)**

ILLUSTRATED TOOL AND EQUIPMENT MANUAL

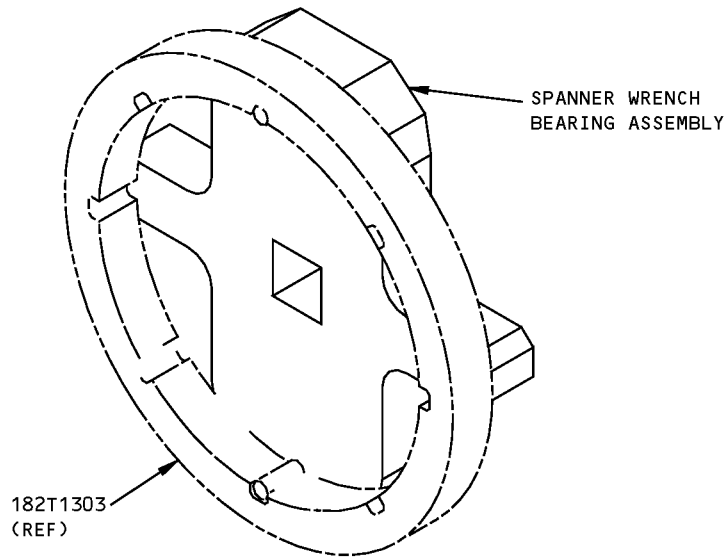

BEARING RING REMOVAL/INSTALLATION

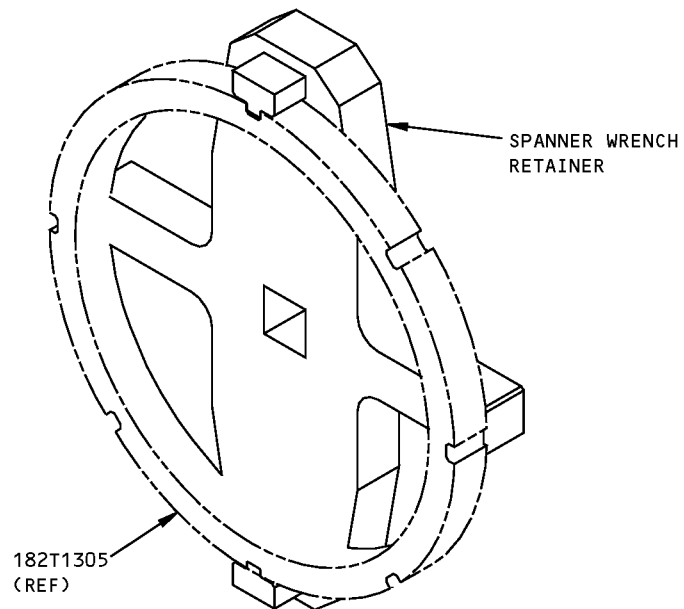

RETAINER RING REMOVAL/INSTALLATION

**Horizontal Stabilizer Pivot Bearing Removal/Installation Equipment
Figure 1 (Sheet 3 of 3)**



767

ILLUSTRATED TOOL AND EQUIPMENT MANUAL

PART NUMBER: A55003-1

NAME: ALIGNMENT EQUIPMENT - HINGE, INBOARD ELEVATOR

AIRPLANE MAINTENANCE: NO

COMPONENT MAINTENANCE: YES

USAGE & DESCRIPTION: The A55003-1 alignment equipment is used on all 767 airplanes. A55003 is used to align the inboard elevator hinge centerline and position of hinge fittings during a hinge replacement. Refer to CMM 55-20-11 for complete usage instructions.

A55003-1		
QUANTITY	NOMENCLATURE	PART NUMBER
1	ALIGNMENT JIG ASSEMBLY	A55003-2
1	PIN	A55003-3
2	PIN	A55003-4
1	STORAGE BOX	

WEIGHT: 16 lbs (7 kg)

DIMENSIONS: 3 x 8 x 53 inches (76 x 203 x 1346 mm)

**767
ILLUSTRATED TOOL AND EQUIPMENT MANUAL**

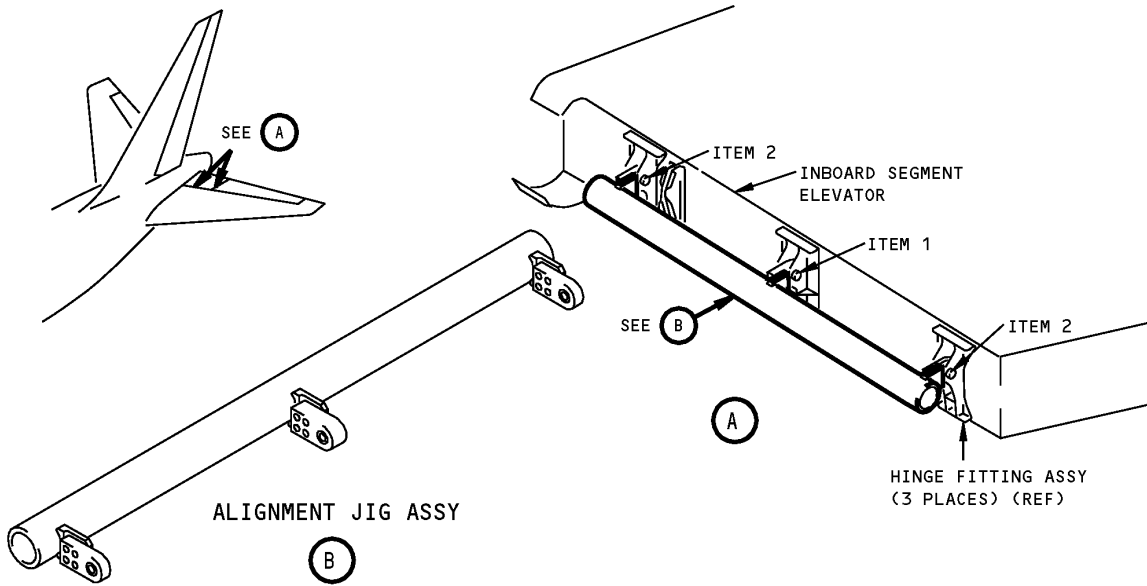

**Inboard Elevator Hinge Alignment Equipment
Figure 1**

REPAIRABLE/REPLACEABLE PARTS			
ITEM NO.	PART NO.	NOMENCLATURE	VENDOR CODE
1	A55003-3	PIN	
2	A55003-4	PIN	

767
ILLUSTRATED TOOL AND EQUIPMENT MANUAL

PART NUMBER: A07007-33

NAME: SLING - VERTICAL FIN INSTALLATION AND REMOVAL

AIRPLANE MAINTENANCE: YES

COMPONENT MAINTENANCE: YES

USAGE & DESCRIPTION: The A07007-33 sling is used on all 767 airplanes. A07007 is used for rotating the vertical fin from airplane attitude to an attitude with the side of fin horizontal with the ground, and back to airplane attitude (2 crane hooks are required, and the rudder must be installed). Refer to the current A07007 drawing for complete usage instructions. A07007-33 consists of an A07007-34 sling assembly contained in a storage box.

WEIGHT: 55 lbs (25 kg)

DIMENSIONS: 12 x 36 x 36 inches (305 x 914 x 914 mm)

NOTE: A07007-33 supersedes A07007-25.

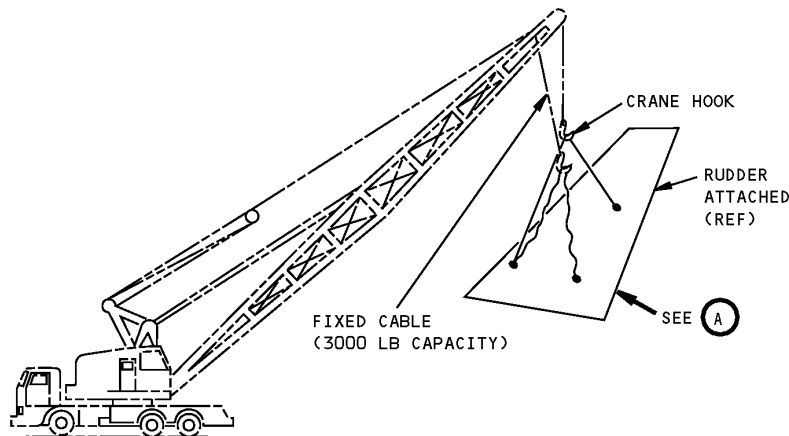

Vertical Fin Installation And Removal Sling
Figure 1 (Sheet 1 of 3)

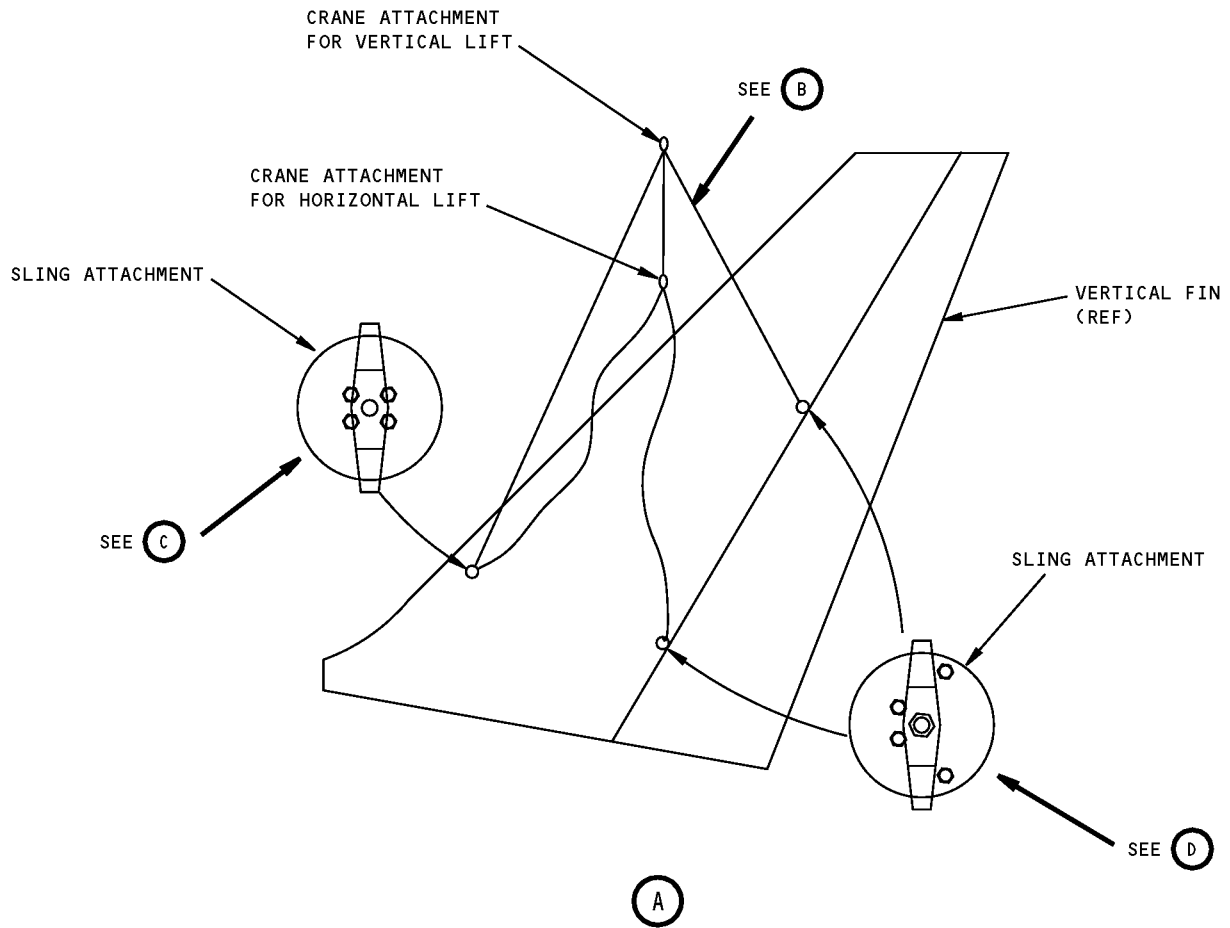

**Vertical Fin Installation And Removal Sling
Figure 1 (Sheet 2 of 3)**

ILLUSTRATED TOOL AND EQUIPMENT MANUAL

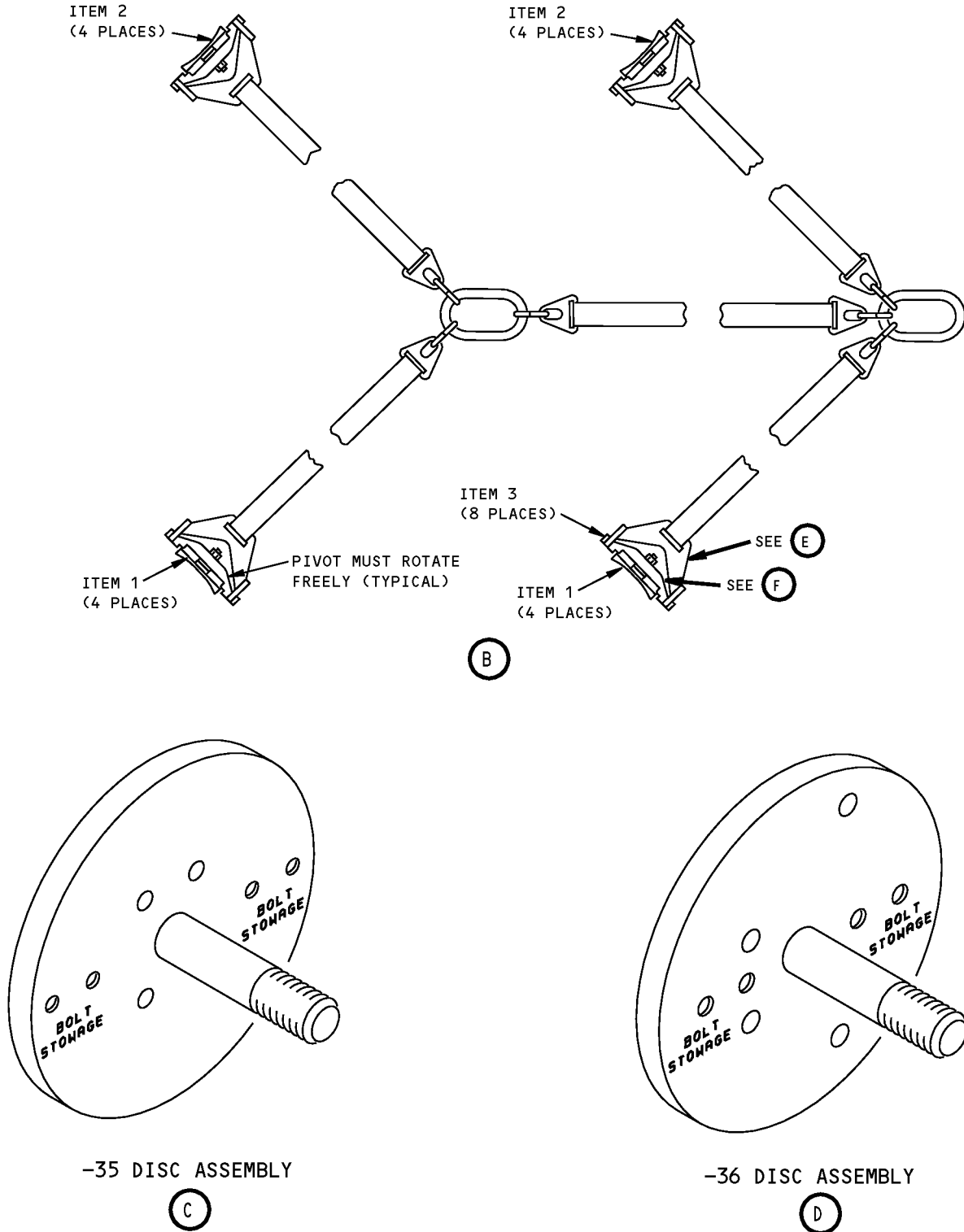

**Vertical Fin Installation And Removal Sling
Figure 1 (Sheet 3 of 3)**



767

ILLUSTRATED TOOL AND EQUIPMENT MANUAL

REPAIRABLE/REPLACEABLE PARTS			
ITEM NO.	PART NO.	NOMENCLATURE	VENDOR CODE
1	BACB30LE3U7	BOLT	
2	BACB30LE4U13	BOLT	
3	NAS6606-4	BOLT	



767

ILLUSTRATED TOOL AND EQUIPMENT MANUAL

PART NUMBER: A07006-1

NAME: TORQUE MULTIPLIER EQUIPMENT - TENSION BOLTS, VERTICAL FIN

AIRPLANE MAINTENANCE: YES

COMPONENT MAINTENANCE: NO

USAGE & DESCRIPTION: The A07006-1 torque multiplier equipment is used on all 767 airplanes. A07006 is used to remove the 16 tension bolts of the vertical fin. Refer to the current A07006 drawing for complete usage instructions. A07006-1 consists of:

A07006-1		
QUANTITY	NOMENCLATURE	PART NUMBER
2	PIPE	A07006-3
1	COUPLING	A07006-4
1	MULTIPLIER WRENCH	GA184A
1	5 INCH EXTENSION BAR	L42
1	UNIVERSAL JOINT	L82A
1	6 INCH EXTENSION BAR	L122
1	1-1/4 SOCKET	LDH342
1	11/16 SOCKET	LDH402
1	BREAKER BAR	SN248
1	STORAGE BOX	

WEIGHT: 18 lbs (8 kg)

DIMENSIONS: 4 x 12 x 46 inches (102 x 305 x 1168 mm)

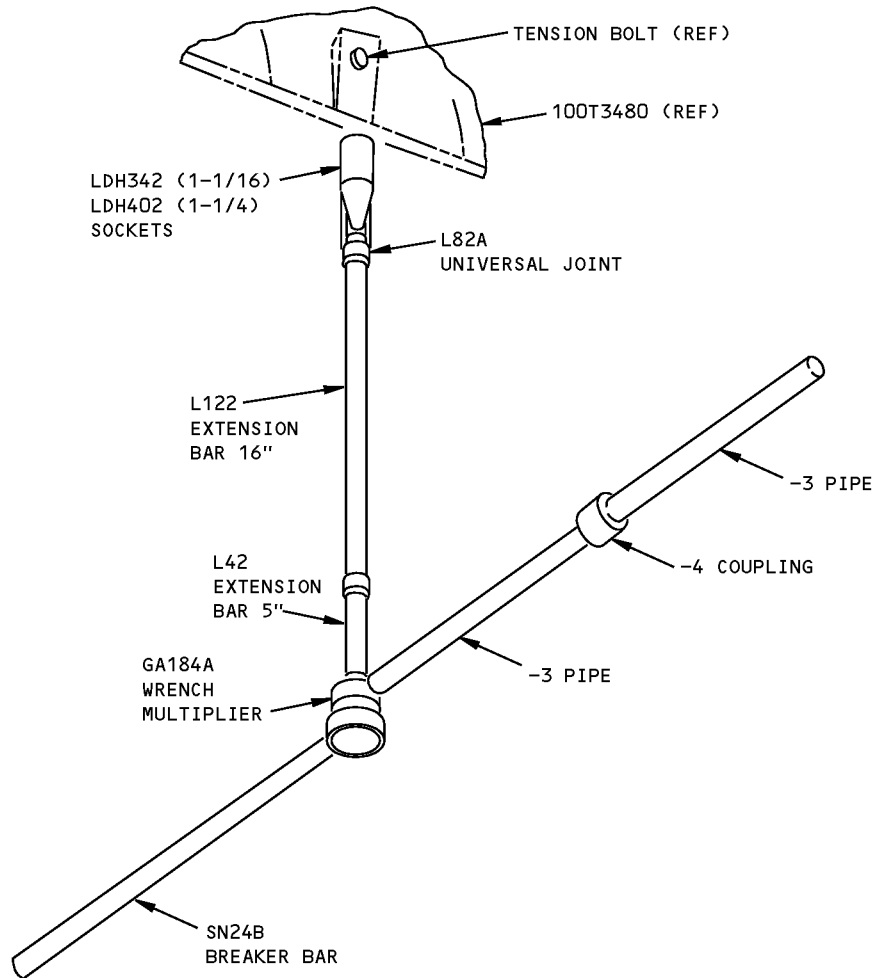

**Vertical Fin Tension Bolts Torque Multiplier Equipment
Figure 1**