

CHAPTER

57

WINGS



767
ILLUSTRATED TOOL AND EQUIPMENT MANUAL

CHAPTER 57
WINGS

Subject/Page	Date	Subject/Page	Date	Subject/Page	Date
EFFECTIVE PAGES					
1	Apr 10/2008				
2	BLANK				
57-CONTENTS					
1	Apr 10/2007				
2	BLANK				
57-30-01					
1	Apr 10/2006				
2	BLANK				
57-40-01					
1	Apr 10/2006				
2	Apr 10/2006				
57-40-02					
1	Apr 10/2007				
2	Oct 10/2006				
3	Oct 10/2006				
4	Apr 10/2007				
57-50-01					
1	Apr 10/2006				
2	Apr 10/2006				
57-50-02					
1	Apr 10/2006				
2	BLANK				
57-50-03					
1	Apr 10/2006				
2	BLANK				
57-50-04					
1	Oct 10/2006				
2	Oct 10/2006				
3	Oct 10/2006				
4	BLANK				

A = Added, R = Revised, O = Overflow, D = Deleted

57-EFFECTIVE PAGES



767

ILLUSTRATED TOOL AND EQUIPMENT MANUAL

TABLE OF CONTENTS

<u>Subject</u>	<u>Title</u>	<u>Part No.</u>
57-	WINGS	
57-30-01	SLING - RAKED WING TIP, INSTALLATION AND REMOVAL	A57004-1
57-40-01	LOCATING EQUIPMENT - WEDGE REPLACEMENT, INBOARD AND OUTBOARD LEADING EDGE SLAT	A57003-1
57-40-02	LUBRICATING EQUIPMENT - LEADING EDGE SLAT AUXILIARY ARM ROLLER BOLT	A57007-8
57-50-01	REPLACEMENT EQUIPMENT - OUTBOARD TRAILING EDGE FLAP	A57002-1
57-50-02	SOCKET ASSEMBLY - RETENTION NUT, MAIN LANDING GEAR ACTUATOR SUPPORT, WING	A57005-1
57-50-03	SPANNER WRENCH - SPECIAL NUT, INBOARD TRAILING EDGE MAIN FLAP	A57006-1
57-50-04	REMOVAL / INSTALLATION EQUIPMENT - MAIN LANDING GEAR BOTTLE PIN	A57008-1

57-CONTENTS

Page 1
Apr 10/2007

D634T501

767
ILLUSTRATED TOOL AND EQUIPMENT MANUAL

PART NUMBER: A57004-1

NAME: SLING - RAKED WING TIP, INSTALLATION AND REMOVAL

AIRPLANE MAINTENANCE: YES

COMPONENT MAINTENANCE: NO

USAGE & DESCRIPTION: The A57004-1 sling is used on 767-400 airplanes. A57004 is used for installation and removal of the raked wing tip. Refer to AMM 57-31-01 for complete usage instructions. A57004-1 consists of an A57004-2 sling assembly, four A57004-4 screws, two A57004-14 screws, all contained in a storage box.

WEIGHT: 19 lbs (8.6 kg)

DIMENSIONS: 12 x 12 x 15 inches (305 x 305 x 381 mm)

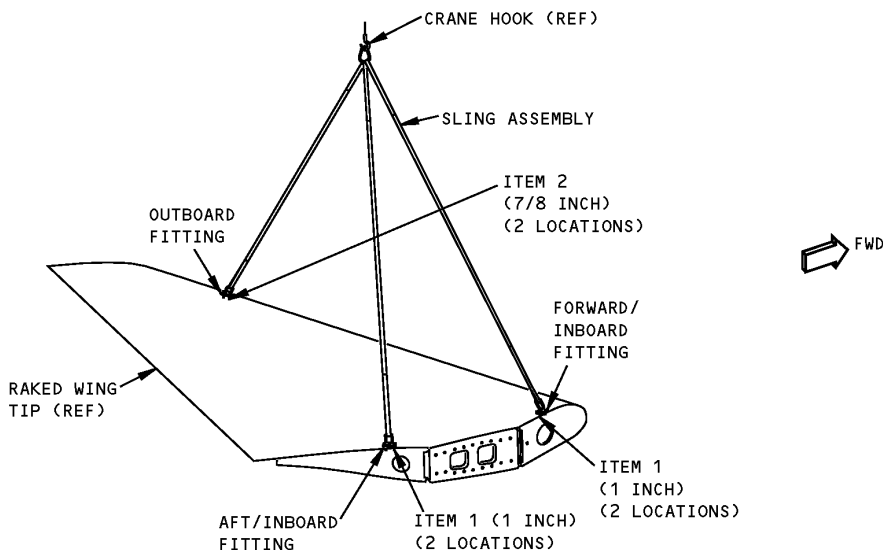

Raked Wing Tip Installation and Removal Sling
Figure 1

REPAIRABLE/REPLACEABLE PARTS			
ITEM NO.	PART NO.	NOMENCLATURE	VENDOR CODE
1	A57004-4	SCREW	
2	A57004-14	SCREW	



767

ILLUSTRATED TOOL AND EQUIPMENT MANUAL

PART NUMBER: A57003-1

NAME: LOCATING EQUIPMENT - WEDGE REPLACEMENT, INBOARD AND OUTBOARD LEADING EDGE SLAT

AIRPLANE MAINTENANCE: NO

COMPONENT MAINTENANCE: YES

USAGE & DESCRIPTION: The A57003-1 locating equipment is used during component maintenance on all 767 airplanes. A57003 is used to locate the inboard and outboard slat trailing edge wedge position during replacement. For complete usage instructions see CMM 57-43-37, CMM 57-43-41, CMM 57-43-45, CMM 57-43-51, CMM 57-43-55 and CMM 57-43-61. A57003-1 consists of:

A57003-1		
QUANTITY	NOMENCLATURE	PART NUMBER
2	INBOARD CLAMP BLOCK	A57003-2
1	INBOARD LEFT HAND TOOL ASSEMBLY	A57003-3
1	INBOARD RIGHT HAND TOOL ASSEMBLY	A57003-4
1	OUTBOARD LEFT HAND TOOL ASSEMBLY	A57003-5
1	OUTBOARD RIGHT HAND TOOL ASSEMBLY	A57003-6
2	OUTBOARD CLAMP BLOCK	A57003-7
1	STORAGE BOX	

WEIGHT: 31 lbs. (14 kg)

DIMENSIONS: 10 x 13 x 18 inches (254 x 330 x 457 mm)

ILLUSTRATED TOOL AND EQUIPMENT MANUAL

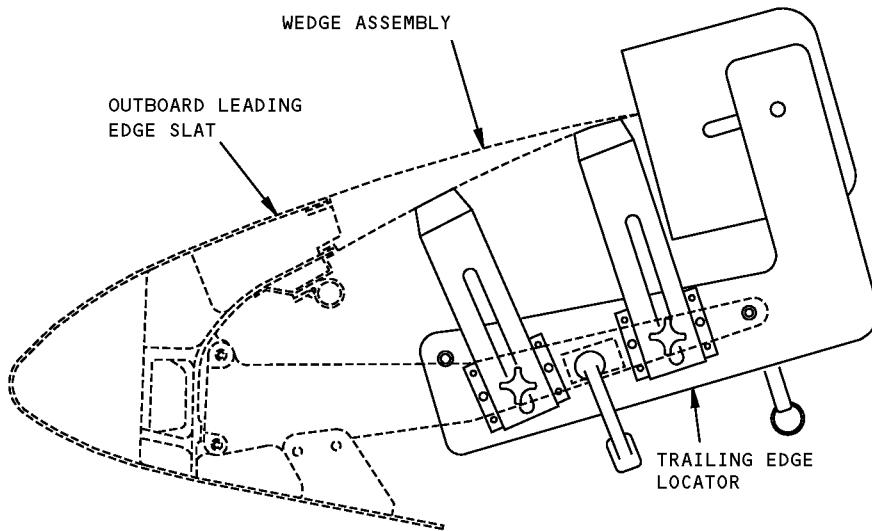
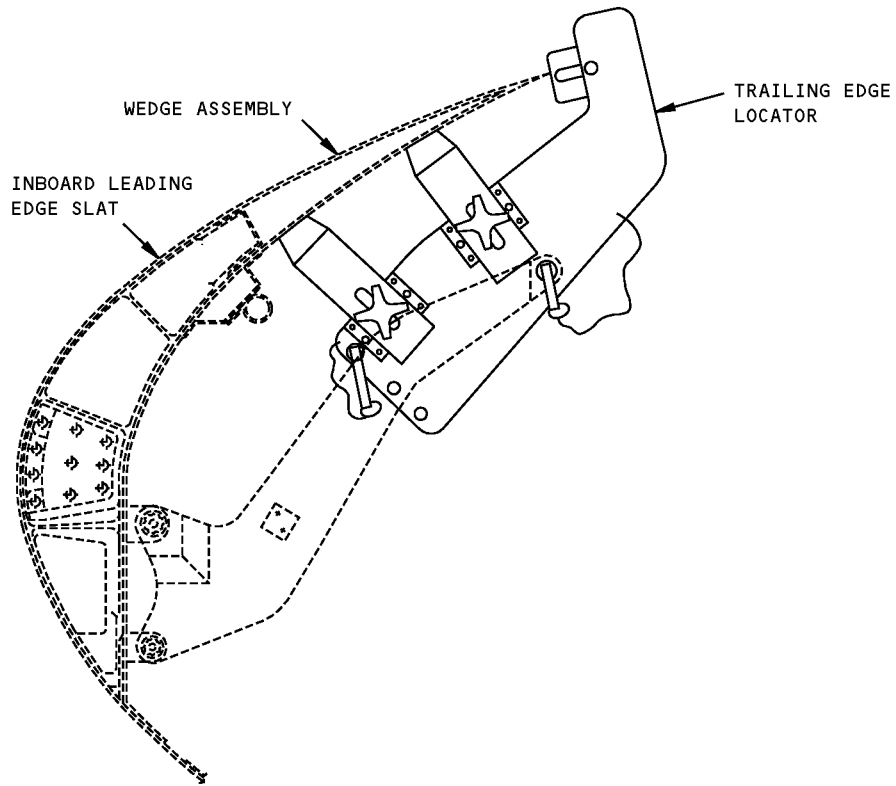

**Inboard and Outboard Leading Edge Slat Wedge Replacement Locating Equipment
Figure 1**



767

ILLUSTRATED TOOL AND EQUIPMENT MANUAL

PART NUMBER: A57007-8

NAME: LUBRICATING EQUIPMENT - LEADING EDGE SLAT AUXILIARY ARM ROLLER BOLT

AIRPLANE MAINTENANCE: YES

COMPONENT MAINTENANCE: NO

USAGE & DESCRIPTION: The A57007-8 lubricating equipment is used on all 767 airplanes. This tool is used to grease the bearing that fits around the leading edge slat auxiliary arm roller bolt. The A57007-3 cap and -9 fitting is used on the inboard auxiliary arm roller bolt. The A57007-5 cap and -10 fitting is used on the outboard auxiliary arm roller bolt. Refer to AMM 12-21-08, Service Letter 767-SL-57-037-B, and current A57007 drawing. The A57007-8 consists of the following:

A57007-8		
QUANTITY	NOMENCLATURE	PART NUMBER
1	FITTING	A57007-9
1	CAP	A57007-3
1	FITTING	A57007-10
1	CAP	A57007-5
1	STORAGE BOX	

WEIGHT: 1.6 lbs (.72 kg)

DIMENSIONS: 2.7 x 2.7 x 2.0 inches (69 x 69 x 50 mm)

NOTE: A57007-8 supersedes A57007-1.

ILLUSTRATED TOOL AND EQUIPMENT MANUAL

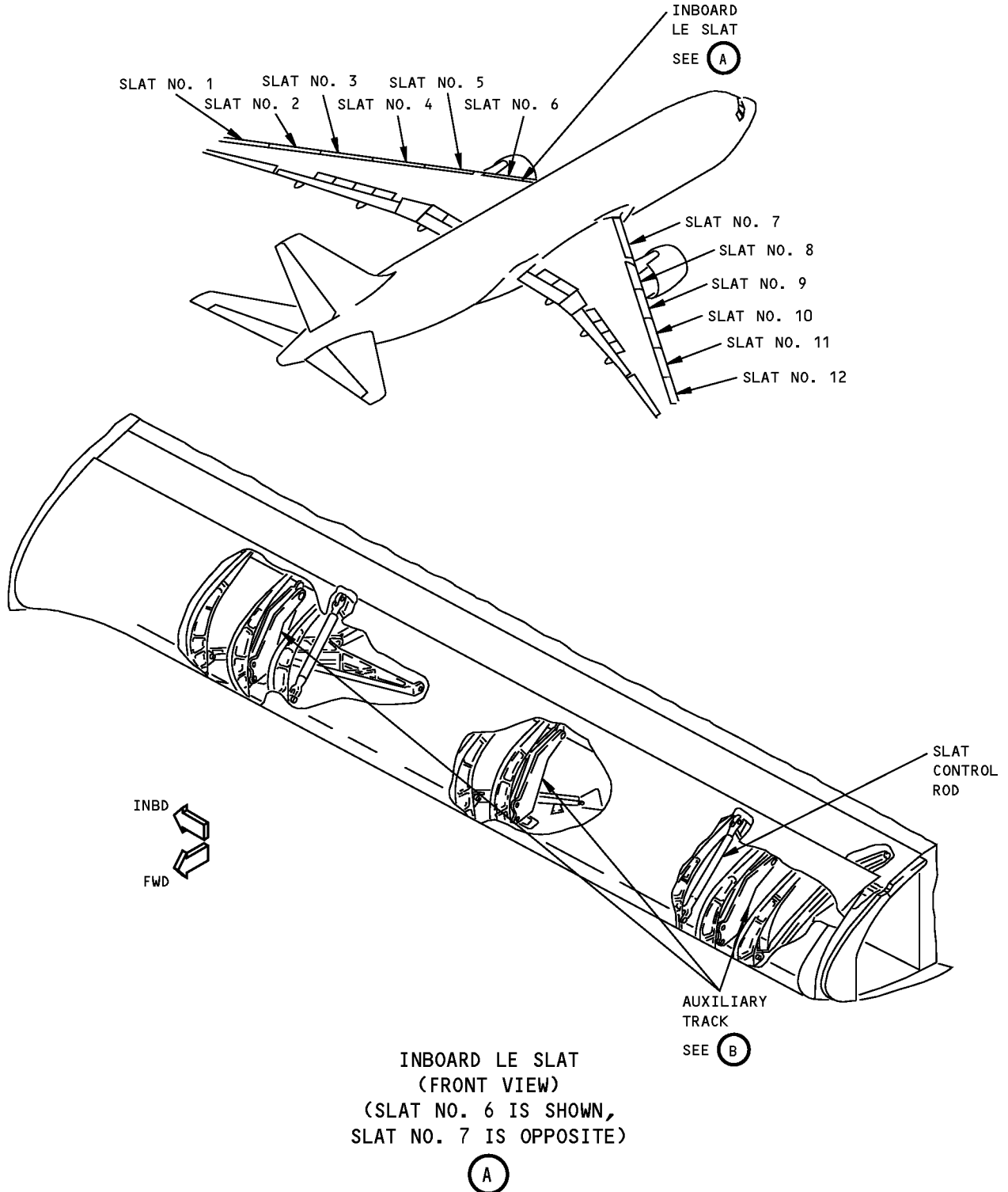

**Lubricating Equipment - Leading Edge Slat Auxiliary Arm Roller Bolt
Figure 1**

**767
ILLUSTRATED TOOL AND EQUIPMENT MANUAL**

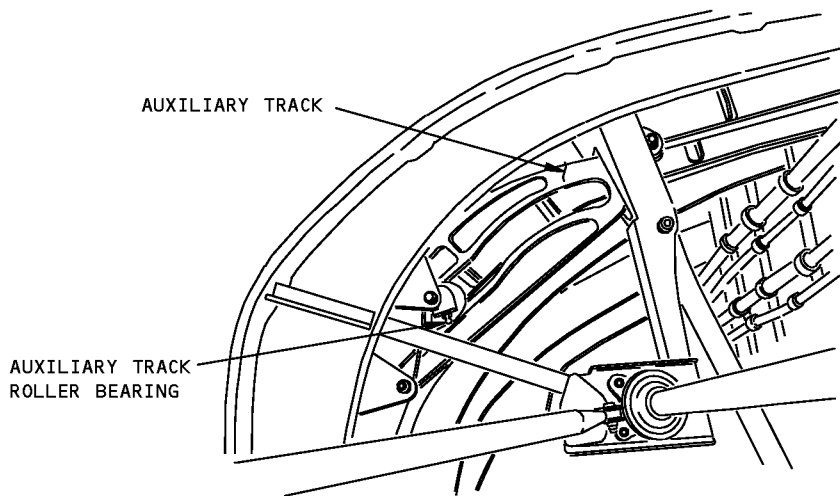
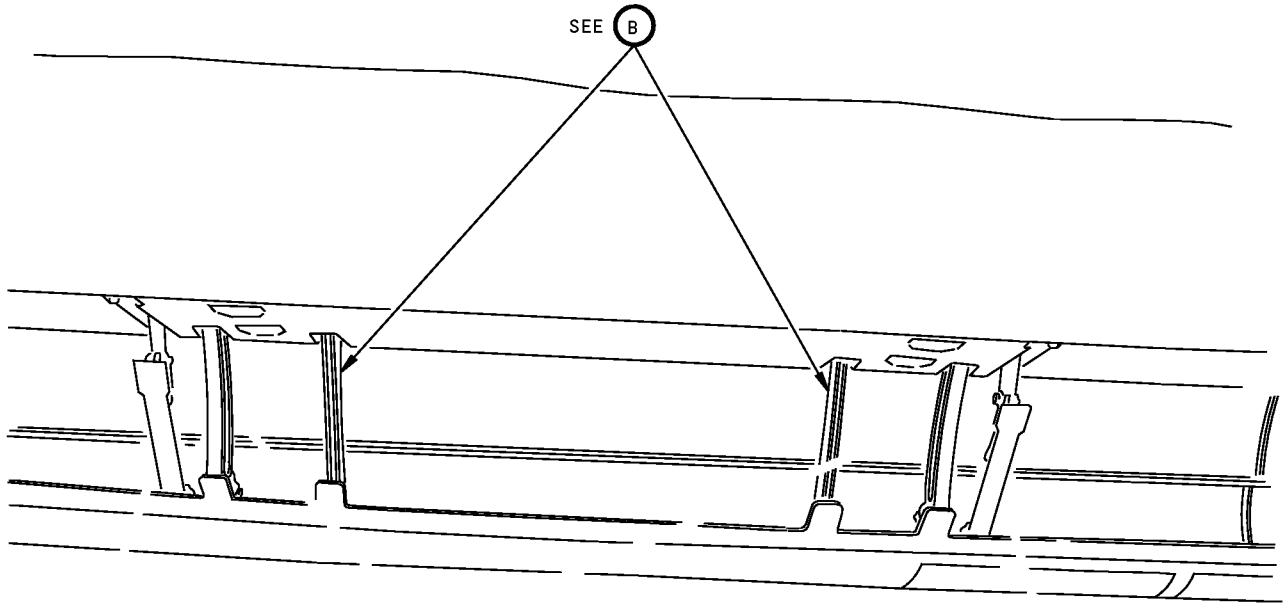

AUXILIARY TRACK
(3 AUXILIARY TRACKS ON EACH INBOARD SLAT)
(INBOARD VIEW)

1 POINT

B

**Lubricating Equipment - Leading Edge Slat Auxiliary Arm Roller Bolt
Figure 2 (Sheet 1 of 2)**

ILLUSTRATED TOOL AND EQUIPMENT MANUAL

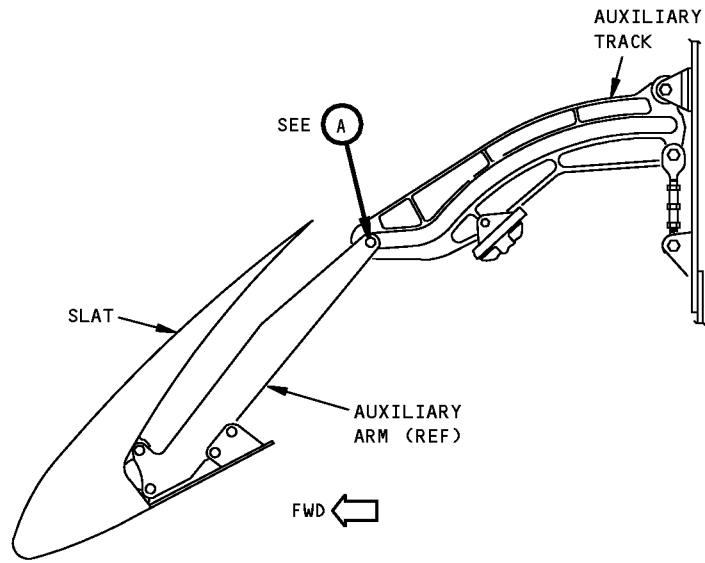

**AUXILIARY TRACK
(2 LOCATIONS)**

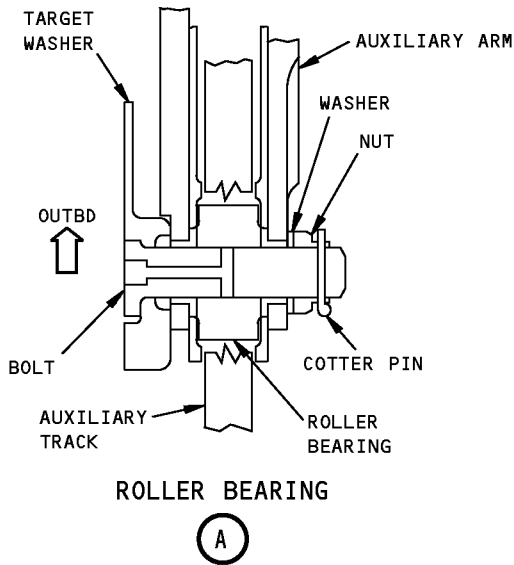

ROLLER BEARING

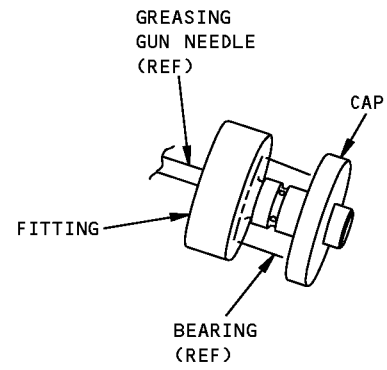

A57007 TOOL

**Lubricating Equipment - Leading Edge Slat Auxiliary Arm Roller Bolt
Figure 2 (Sheet 2 of 2)**



767

ILLUSTRATED TOOL AND EQUIPMENT MANUAL

PART NUMBER: A57002-1

NAME: REPLACEMENT EQUIPMENT - OUTBOARD TRAILING EDGE FLAP

AIRPLANE MAINTENANCE: NO

COMPONENT MAINTENANCE: YES

USAGE & DESCRIPTION: The A57002-1 replacement equipment is used during component maintenance on all 767 airplanes. A57002 is used for replacing the wedge assembly of the outboard trailing edge flap. Refer to CMM 57-53-51 for complete usage instructions. A57002-1 consists of :

A57002-1		
QUANTITY	NOMENCLATURE	PART NUMBER
1	RIGGING BAR ASSEMBLY	A57002-3
1	RIGGING BAR ASSEMBLY	A57002-4
1	RIGGING BAR ASSEMBLY	A57002-5
1	RIGGING BAR ASSEMBLY	A57002-6
1	RIGGING BAR ASSEMBLY	A57002-7
10	WEDGE	A57002-14
5	FEELER	A57002-15
5	WEBBING ASSEMBLY	A57002-22
2	STANDOFF ASSEMBLY	A57002-27
2	STANDOFF ASSEMBLY	A57002-28
2	STANDOFF ASSEMBLY	A57002-29
1	STORAGE BOX	

WEIGHT: 20 lbs (9 kg)

DIMENSIONS: 5 x 15 x 45 inches (127 x 381 x 1143 mm)

ILLUSTRATED TOOL AND EQUIPMENT MANUAL

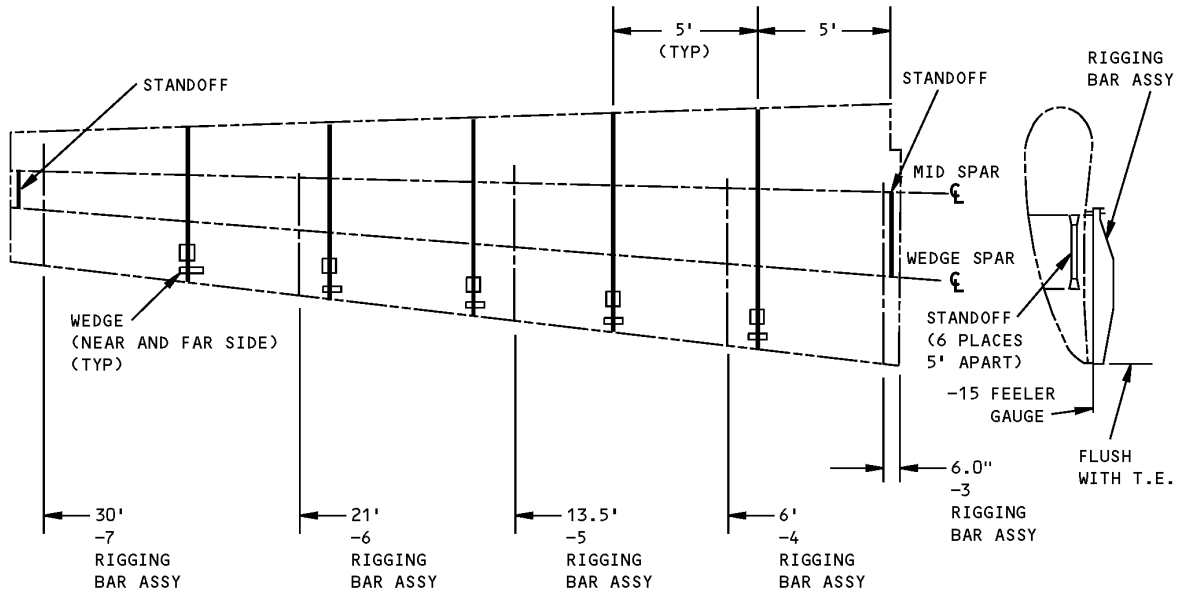

**Outboard Trailing Edge Flap Replacement Equipment
Figure 1**

ILLUSTRATED TOOL AND EQUIPMENT MANUAL

PART NUMBER: A57005-1

NAME: SOCKET ASSEMBLY - RETENTION NUT, MAIN LANDING GEAR ACTUATOR SUPPORT, WING

AIRPLANE MAINTENANCE: NO

COMPONENT MAINTENANCE: YES

USAGE & DESCRIPTION: The A57005-1 socket assembly is used on all 767 airplanes. A57005 is used to remove and install the main landing gear actuator wing bearing retention nut. Refer to CMM 57-54-39 for complete usage instructions. A57005-1 consists of a A57005-2 socket assembly contained in a storage box.

WEIGHT: 4 lbs (1.8 kg)

DIMENSIONS: 3 x 7 x 7 inches (76 x 178 x 178 mm)

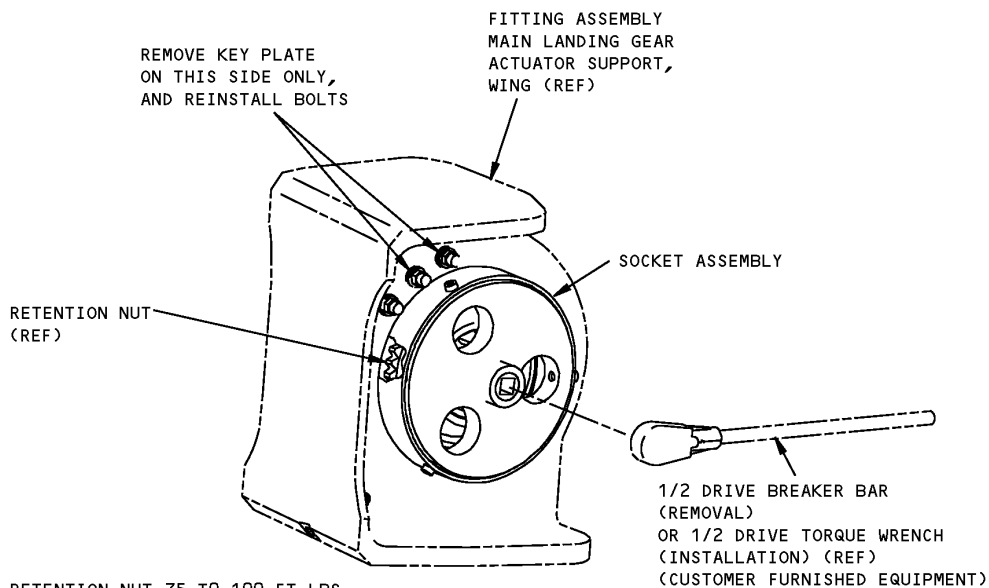

NOTE: TORQUE RETENTION NUT 75 TO 100 FT-LBS

**Wing Main Landing Gear Actuator Support Retention Nut Socket Assembly
Figure 1**

ILLUSTRATED TOOL AND EQUIPMENT MANUAL

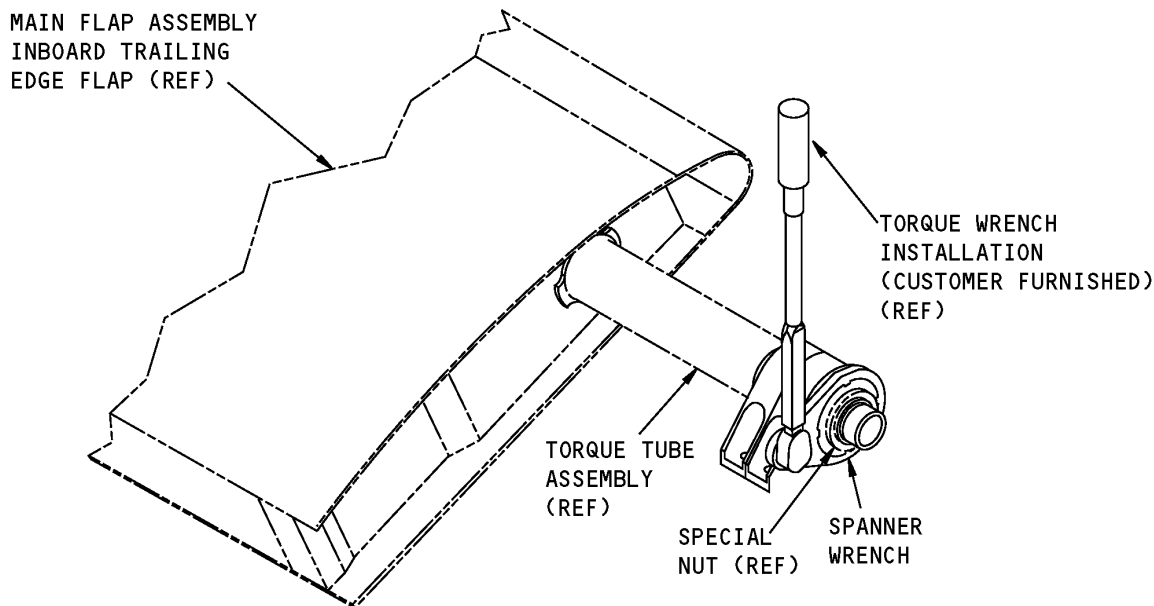
PART NUMBER: A57006-1**NAME:** SPANNER WRENCH - SPECIAL NUT, INBOARD TRAILING EDGE MAIN FLAP**AIRPLANE MAINTENANCE:** NO**COMPONENT MAINTENANCE:** YES**USAGE & DESCRIPTION:** The A57006-1 spanner wrench is used during component maintenance on all 767 airplanes. A57006 is used for the removal and installation of the special nut on the inboard trailing edge main flap torque tube assembly. Refer to the current A57006 -1 drawing for complete usage instructions. A57006-1 consists of an A57006-2 spanner wrench contained in a storage box.**WEIGHT:** 2 lbs (0.9 kg)**DIMENSIONS:** 1 x 5 x 8 inches (25 x 127 x 203 mm)

**Inboard Trailing Edge Main Flap, Special Nut, Spanner Wrench
Figure 1**



767

ILLUSTRATED TOOL AND EQUIPMENT MANUAL

PART NUMBER: A57008-1

NAME: REMOVAL / INSTALLATION EQUIPMENT - MAIN LANDING GEAR BOTTLE PIN

AIRPLANE MAINTENANCE: YES

COMPONENT MAINTENANCE: NO

USAGE & DESCRIPTION: The A57008-1 removal and installation equipment is used on all 767 airplanes. This tool is a spanner wrench that is used to remove and install the main landing gear bottle pin (part number 113T1144). To remove the 113T1144 bottle pin, the tool is used in conjunction with a customer furnished breaker bar. To install the 113T1144 bottle pin, the tool is used in conjunction with a customer furnished torque wrench. Refer to AMM 57-54-06 and current A57008 drawing for additional instructions. The A57008-1 consists of the following:

A57008-1		
QUANTITY	NOMENCLATURE	PART NUMBER
1	WRENCH ASSEMBLY	A57008-2
1	BAR	A57008-4
2	NUT	A57008-5
2	WASHER	A57008-6
1	STORAGE BOX	

WEIGHT: 6.4 lbs (2.9 kg)

DIMENSIONS: 3 x 4 x 26 inches (76 x 102 x 660 mm)

**767
ILLUSTRATED TOOL AND EQUIPMENT MANUAL**

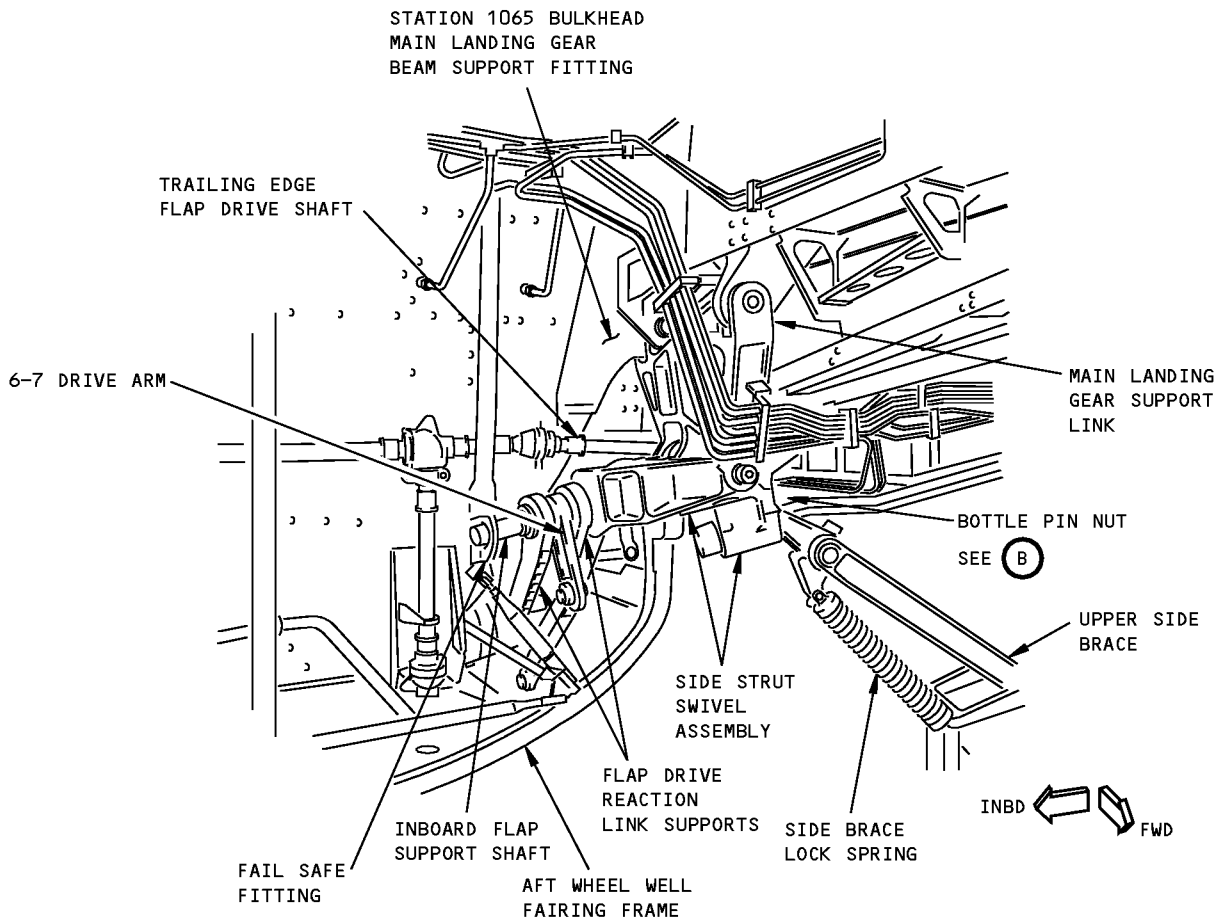
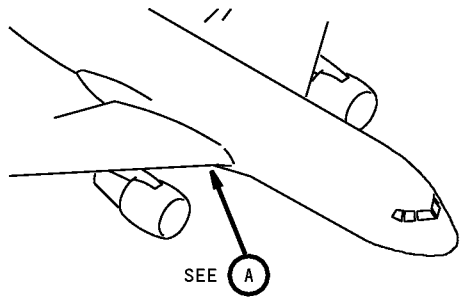

LEFT MAIN LANDING GEAR WHEEL WELL
(RIGHT MAIN LANDING GEAR WHEEL WELL IS OPPOSITE)

A

**Main Landing Gear Strut Swivel Fitting Installation
Figure 1 (Sheet 1 of 2)**

ILLUSTRATED TOOL AND EQUIPMENT MANUAL

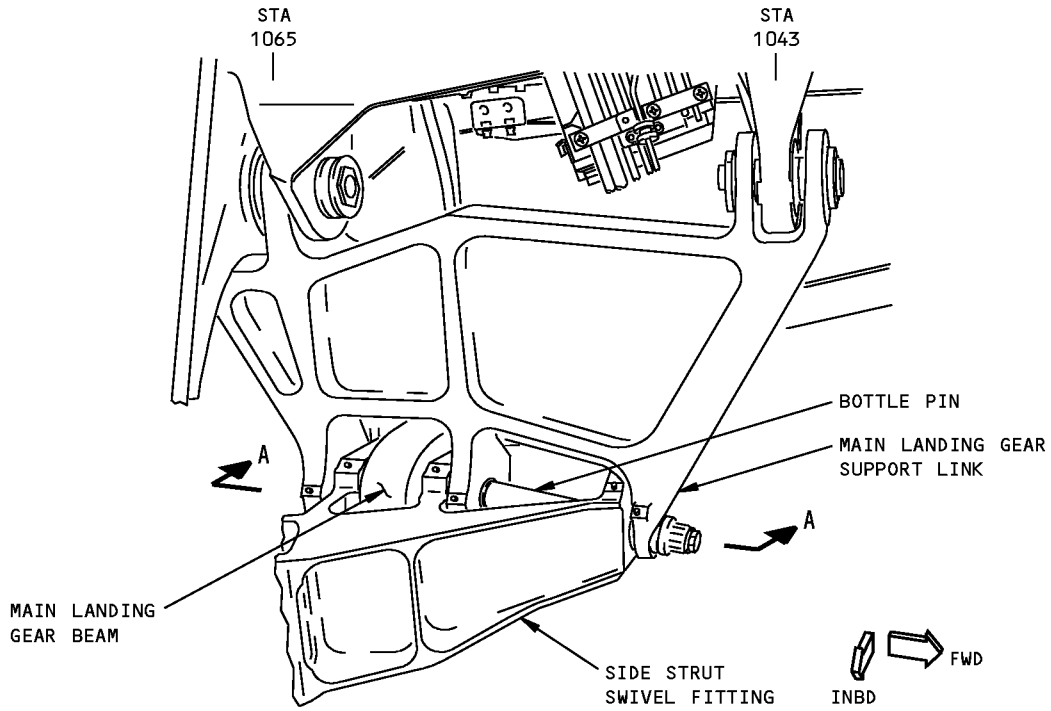

LEFT SIDE IS SHOWN, RIGHT SIDE IS OPPOSITE
(HYDRAULIC LINES NOT SHOWN FOR CLARITY)

B

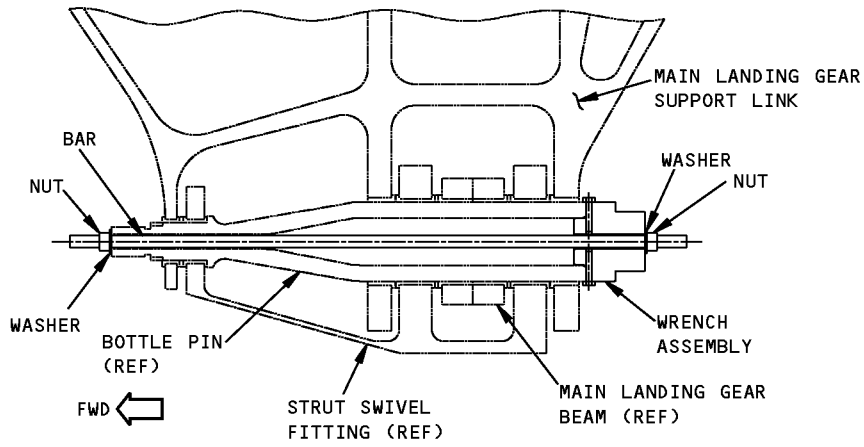

RIGHT SIDE IS SHOWN, LEFT SIDE IS OPPOSITE
A-A

**Main Landing Gear Strut Swivel Fitting Installation
Figure 1 (Sheet 2 of 2)**