

**CHAPTER**

**71**

**POWER PLANT**



767

ILLUSTRATED TOOL AND EQUIPMENT MANUAL

CHAPTER 71  
POWER PLANT

Subject/Page	Date	Subject/Page	Date	Subject/Page	Date
EFFECTIVE PAGES		71-00-05 (cont)		71-00-13	
1 thru 3	Apr 10/2008	4	Apr 10/2006	1	Apr 10/2006
4	BLANK	5	Apr 10/2006	2	Apr 10/2006
71-CONTENTS		6	Apr 10/2006	3	Apr 10/2006
1	Oct 10/2006	7	Apr 10/2006	4	Apr 10/2006
2	Oct 10/2006	8	Apr 10/2006	5	Oct 10/2007
3	Apr 10/2006	71-00-06		6	BLANK
4	BLANK	1	Apr 10/2006	71-00-14	
71-00-01		2	Apr 10/2006	1	Apr 10/2006
1	Apr 10/2007	3	Apr 10/2006	2	Apr 10/2006
2	Apr 10/2007	4	Apr 10/2006	3	Apr 10/2006
3	Oct 10/2006	71-00-07		4	Apr 10/2006
4	Apr 10/2006	1	Apr 10/2006	5	Apr 10/2006
5	Apr 10/2006	2	Apr 10/2006	6	BLANK
6	Apr 10/2006	71-00-08		71-00-15	
7	Apr 10/2006	1	Apr 10/2006	1	Apr 10/2006
8	Apr 10/2006	2	Apr 10/2006	2	Apr 10/2006
9	Apr 10/2006	3	Apr 10/2006	3	Apr 10/2006
10	BLANK	4	Apr 10/2006	4	BLANK
71-00-02		71-00-09		71-00-16	
1	Apr 10/2006	1	Oct 10/2006	1	Apr 10/2006
2	Apr 10/2006	2	Oct 10/2006	2	Apr 10/2006
3	Apr 10/2006	3	Oct 10/2006	3	Apr 10/2006
4	BLANK	4	Apr 10/2006	4	Apr 10/2006
71-00-03		5	Apr 10/2006	71-00-17	
1	Apr 10/2006	6	Apr 10/2006	1	Apr 10/2006
2	Apr 10/2006	7	Apr 10/2006	2	BLANK
3	Apr 10/2006	8	Apr 10/2006	71-00-18	
4	Apr 10/2006	71-00-10		1	Apr 10/2006
5	Apr 10/2006	1	Apr 10/2006	2	Apr 10/2006
6	Apr 10/2006	2	Apr 10/2006	71-00-19	
71-00-04		3	Oct 10/2007	1	Apr 10/2006
1	Apr 10/2006	4	BLANK	2	BLANK
2	Apr 10/2006	71-00-11		71-00-20	
3	Apr 10/2006	1	Apr 10/2006	1	Apr 10/2006
4	Apr 10/2006	2	Apr 10/2006	2	BLANK
71-00-05		71-00-12		71-00-21	
1	Oct 10/2006	1	Apr 10/2006	1	Apr 10/2006
2	Oct 10/2006	2	BLANK	2	Apr 10/2006
3	Apr 10/2006			3	Apr 10/2006

A = Added, R = Revised, O = Overflow, D = Deleted

# 71-EFFECTIVE PAGES



**767**  
**ILLUSTRATED TOOL AND EQUIPMENT MANUAL**

**CHAPTER 71**  
**POWER PLANT**

Subject/Page	Date	Subject/Page	Date	Subject/Page	Date
71-00-21 (cont)		71-00-34		71-00-44 (cont)	
4	BLANK	1	Apr 10/2006	6	Apr 10/2006
71-00-22		2	Apr 10/2006	7	Apr 10/2006
1	Apr 10/2006	3	Apr 10/2006	8	Apr 10/2006
2	Apr 10/2006	4	BLANK	9	Apr 10/2006
71-00-23		71-00-35		10	Apr 10/2006
1	Apr 10/2007	1	Apr 10/2006	11	Apr 10/2006
2	BLANK	2	BLANK	12	BLANK
71-00-24		71-00-36		71-00-45	
1	Apr 10/2006	1	Apr 10/2006	1	Apr 10/2006
2	Apr 10/2006	2	Apr 10/2006	2	BLANK
71-00-25		71-00-37		71-00-46	
1	Apr 10/2006	1	Apr 10/2006	1	Apr 10/2006
2	Apr 10/2006	2	BLANK	2	Apr 10/2006
3	Apr 10/2006	71-00-38		3	Apr 10/2006
4	Apr 10/2006	1	Apr 10/2006	4	BLANK
71-00-26		2	BLANK	71-00-47	
1	Apr 10/2006	71-00-39		1	Apr 10/2006
2	BLANK	1	Apr 10/2006	2	Apr 10/2006
71-00-27		2	BLANK	71-00-48	
1	Apr 10/2006	71-00-40		1	Apr 10/2006
2	Apr 10/2006	1	Apr 10/2006	2	Apr 10/2006
71-00-28		2	BLANK	71-00-49	
1	Apr 10/2006	71-00-41		1	Apr 10/2006
2	Apr 10/2006	1	Apr 10/2006	2	Apr 10/2006
71-00-29		2	Apr 10/2006	71-10-01	
1	Apr 10/2006	71-00-42		1	Apr 10/2006
2	BLANK	1	Apr 10/2006	2	Apr 10/2006
71-00-30		2	Apr 10/2006	71-10-02	
1	Apr 10/2006	3	Apr 10/2006	1	Apr 10/2006
2	BLANK	4	Apr 10/2006	2	Apr 10/2006
71-00-31		71-00-43		71-10-03	
1	Apr 10/2006	1	Apr 10/2006	1	Apr 10/2006
2	BLANK	2	BLANK	2	Apr 10/2006
71-00-32		71-00-44		71-10-04	
1	Apr 10/2006	1	Apr 10/2006	1	Oct 10/2006
2	Apr 10/2006	2	Apr 10/2006	2	Oct 10/2006
71-00-33		3	Apr 10/2006	71-10-05	
1	Apr 10/2006	4	Apr 10/2006	1	Apr 10/2006
2	BLANK	5	Apr 10/2006	2	Apr 10/2006

A = Added, R = Revised, O = Overflow, D = Deleted

# 71-EFFECTIVE PAGES



767

ILLUSTRATED TOOL AND EQUIPMENT MANUAL

CHAPTER 71  
POWER PLANT

Subject/Page	Date	Subject/Page	Date	Subject/Page	Date
71-10-06					
1	Oct 10/2007				
2	Oct 10/2007				
3	Apr 10/2006				
4	Apr 10/2006				
71-10-07					
1	Apr 10/2006				
2	Apr 10/2006				
71-10-08					
1	Apr 10/2006				
2	Apr 10/2006				
3	Apr 10/2006				
4	Apr 10/2006				
5	Apr 10/2006				
6	BLANK				
71-10-09					
1	Apr 10/2006				
2	BLANK				
71-10-10					
1	Apr 10/2006				
2	BLANK				
71-10-11					
1	Apr 10/2006				
2	BLANK				
71-10-12					
1	Apr 10/2006				
2	BLANK				
71-10-13					
1	Apr 10/2006				
2	BLANK				
71-20-01					
1	Apr 10/2006				
2	BLANK				

A = Added, R = Revised, O = Overflow, D = Deleted

# 71-EFFECTIVE PAGES

Page 3  
Apr 10/2008

D634T501



767

## ILLUSTRATED TOOL AND EQUIPMENT MANUAL

### TABLE OF CONTENTS

<u>Subject</u>	<u>Title</u>	<u>Part No.</u>
<b>71-</b>	<b>POWER PLANT</b>	
71-00-01	BOOTSTRAP EQUIPMENT - PRATT AND WHITNEY ENGINES	A71001-191
71-00-02	PROOF LOAD FIXTURE - BOOTSTRAP, PRATT AND WHITNEY ENGINES, JT9D7R4 AND PW4000	A71007-27, -39
71-00-03	SLING EQUIPMENT - PRATT AND WHITNEY ENGINE	A71008-1, -64, -65
71-00-04	PROOF LOAD EQUIPMENT - CRADLE, PRATT AND WHITNEY ENGINE	A71012-35
71-00-05	HOIST ADAPTER - INTEGRATED DRIVE GENERATOR	A71013-19, -32, -40, -45, -55, -82, -88
71-00-06	LIFT SLING - CORE COWL	A71017-1
71-00-07	PT2 PROBE ADAPTER	A71049-1
71-00-08	TORQUE EQUIPMENT - ENGINE MOUNTS, JT9D-7R4D AND PW4000 ENGINES	A71003-25, -41, -53, -54
71-00-09	BOOTSTRAP EQUIPMENT - GENERAL ELECTRIC ENGINE	A71011-262, -263
71-00-10	ENGINE HANDLING EQUIPMENT - CF6-80A	A71019-60
71-00-11	PROOF LOAD FIXTURE - CRADLE, CF6-80A ENGINE	A71020-1
71-00-12	PROOF LOAD FIXTURE - BOOTSTRAP, GE ENGINES	A71021-52
71-00-13	CRADLE - CF6-80A ENGINE 90 - INCH RAIL	A71023-53, -56
71-00-14	CRADLE - PRATT AND WHITNEY ENGINES, 90-INCH RAIL	A71006-79
71-00-15	SUPPORT PEDESTAL EQUIPMENT - CF6-80A ENGINE BUILDUP	A71025-1
71-00-16	LOCATING JIG - CF6-80A BUILDUP-TO-STRUT SYSTEM INTERFACES	A71024-1, -51, -68, -70
71-00-17	LOCATING JIG - ENGINE BUILDUP TO STRUT SYSTEMS INTERFACES JT9D-7R4D ENGINE	A71022-1, -60
71-00-18	HOLD OPEN EQUIPMENT - FAN COWL, 40 KNOTS, PRATT AND WHITNEY ENGINES	A71030-32
71-00-19	HOLD-OPEN EQUIPMENT - 40 KNOTS, PRATT AND WHITNEY CORE COWLS	A71032-14
71-00-20	WRENCH - AFT FLIGHT MOUNT ENGINE BUILDUP (EBU) "B" PACKAGE	A71034-1, -2, -3
71-00-21	TEST EQUIPMENT - ENGINE PRESSURE MONITORING	B71034-13, -29, -48
71-00-22	HOLD OPEN EQUIPMENT - FAN COWL, 20 KNOT, JT9D-7R4 ENGINE	A71029-36
71-00-23	MONITORING ASSEMBLY - BREATHER PRESSURE, JT9D-7R4 ENGINE	A71036-1
71-00-24	TEST EQUIPMENT - DRYING AND LEAK CHECK, JT9D-7R4D GEARBOX	A71037-1
71-00-25	COVER EQUIPMENT - BLEED VALVE, GE ENGINE	A71035-1, -13, -27

# 71-CONTENTS



767

## ILLUSTRATED TOOL AND EQUIPMENT MANUAL

<u>Subject</u>	<u>Title</u>	<u>Part No.</u>
71-00-26	GUARD - INLET, ENGINE RUN-UP	A71042-1, -29
71-00-27	EQUIPMENT - ENGINE SUPPORT	PWA 25056, 25757, 25758, 29245
71-00-28	SLING EQUIPMENT - ENGINE INLET COWL	A71005-33
71-00-29	SPECIFICATION - FLUSH CART, ENGINE INTEGRATED DRIVE GENERATOR (IDG) COOLING SYSTEM	A71040
71-00-30	SLING EQUIPMENT - INLET COWL, CF6-80C2B ENGINE	G71007-28
71-00-32	PROOF LOAD EQUIPMENT - CRADLE, CF6-80C2B ENGINE	G71008-1
71-00-33	CRADLE - CF6-80C2B ENGINE	G71002-48
71-00-34	SLING - ENGINE HANDLING, GE ENGINES	G71010-79, -80, -81
71-00-35	STORAGE STAND - SPARE ENGINE CARRIAGE	A71045-1
71-00-36	LOCATING JIG - ENGINE BUILDUP TO STRUT, CF6-80C2B ENGINE	G71012-107, -118, -119
71-00-37	BEAM - ENGINE HANDLING, RB211-524	G71014-1
71-00-38	SLING - FAN COWL, CF6-80C2B ENGINE	G71013-1
71-00-39	WRENCH - FLEX NUT, 15TH STAGE, MANIFOLD AND DUCT, PW4000	G71020-1
71-00-40	PROOF LOAD FIXTURE - RB211-524 ENGINE	G71017-1
71-00-41	SUPPORT EQUIPMENT - RB211-524 ENGINE, H2 HANDLING ATTACHMENT	G71018-1
71-00-42	CRADLE - RB211-524 (G AND H) ENGINE	G71015-75
71-00-43	PROOF LOAD FIXTURE - BOOTSTRAP, RB211 ENGINE	A71048-1
71-00-44	BOOTSTRAP EQUIPMENT - RB211-524H	A71047-150
71-00-45	LOCATING JIG - ENGINE BUILDUP (EBU) TO STRUT, SYSTEM PW4000	A71046-1
71-00-46	ADAPTER EQUIPMENT - LOAD TEST, PRESSURE RELIEF DOOR LATCH	B71044-10, -28
71-00-47	TORQUE EQUIPMENT - ENGINE MOUNT BOLTS, RB211-524G/H	A71054-1
71-00-48	TOOL SET, RB211 ENGINE MOUNT BOLT	3MIT65B89603
71-00-49	SPECIFICATION - POWERED HOIST SYSTEM, GROUND SUPPORT EQUIPMENT (GSE) OPERATIONS	J71006
71-10-01	HOLD OPEN EQUIPMENT - ENGINE FAN/CORE COWL, CF6-80C2B	G71022-44
71-10-02	SLING EQUIPMENT - CORE COWL	A71016-1, -23
71-10-03	HOLD OPEN EQUIPMENT - 40-KNOT, CF6-80A FAN COWL	A71026-1
71-10-04	HOLD OPEN EQUIPMENT - 40-KNOT, CF6-80A CORE COWL	A71033-31
71-10-05	HOLD OPEN EQUIPMENT - FAN COWL, 20 KNOTS, CF6-80A ENGINE	A71027-1
71-10-06	SLING EQUIPMENT - INLET COWL	B71040-36, -37, -39

# 71-CONTENTS

Page 2  
Oct 10/2006

D634T501



767

## ILLUSTRATED TOOL AND EQUIPMENT MANUAL

<u>Subject</u>	<u>Title</u>	<u>Part No.</u>
71-10-07	HOLD OPEN EQUIPMENT - 20 KNOT, PW4000 FAN AND CORE COWLS	G71023-52
71-10-08	TEST/OVERHAUL EQUIPMENT - COWL DOOR ACTUATOR	A78021-45, -46
71-10-09	HOLD OPEN BRACKET - JT9D ENGINE	A71050-1
71-10-10	TRANSPORTATION AND STORAGE PALLET - INLET COWL, CF6-80C2B ENGINE	A71051-1
71-10-11	SLING EQUIPMENT - INLET COWL, CF6-50 AND RB211-524 ENGINES	G71032-1
71-10-13	SLING EQUIPMENT - NOSE COWL, RB211-524 AND CF6-50 ENGINES	G71030-1
71-20-01	ALIGNMENT HANDLE - FORWARD ENGINE MOUNT	A71038-1

# 71-CONTENTS

Page 3  
Apr 10/2006

D634T501



767

## ILLUSTRATED TOOL AND EQUIPMENT MANUAL

**PART NUMBER: A71001-191**

**NAME:** BOOTSTRAP EQUIPMENT - PRATT AND WHITNEY ENGINES

**AIRPLANE MAINTENANCE:** YES

**COMPONENT MAINTENANCE:** NO

**USAGE & DESCRIPTION:** The A71001 bootstrap equipment is used on 767 airplanes equipped with Pratt and Whitney JT9D-7R4D or PW4056-4060 engines. A71001 is used in conjunction with the A71006 engine cradle to remove and install Pratt and Whitney JT9D-7R4D or PW4056-4060 engines. Refer to AMM 71-00-02 and the current A71001 drawing for additional usage instructions. A71001-191 consists of the following:

A71001-191		
QUANTITY	NOMENCLATURE	PART NUMBER
1	INBOARD AFT BRACE ASSEMBLY	A71001-9
1	OUTBOARD AFT BRACE ASSEMBLY	A71001-10
1	CABLE ASSEMBLY	A71001-18
1	4 INCH SHEAVE	A71001-19
2	6 INCH SHEAVE	A71001-20
2	HOLD OPEN AFT BRACKET ASSEMBLY	A71001-116
1	CLAMP ASSEMBLY	A71001-192
1	CLAMP ASSEMBLY	A71001-193
1	OUTBOARD LINK ASSEMBLY	A71001-144
1	INBOARD LINK ASSEMBLY	A71001-145
1	INBOARD AFT ARM ASSEMBLY	A71001-147
1	OUTBOARD AFT ARM ASSEMBLY	A71001-148
2	UPPER AFT BRACKET ASSEMBLY	A71001-160 (OR-165)
1	LOAD CELL ASSEMBLY	A71001-164
1	SUPPORT ASSEMBLY	A71001-169
2	3 TON LEVER HOIST	A71001-180
2	6 TON LEVER HOIST	A71001-181
2	LOWER AFT BRACKET ASSEMBLY	A71001-186
2	DYNAMOMETER	30006-0092
8	BOLT	BACB30US4K14
8	BOLT	BACB30US5K19
4	BOLT	BACB30US6K19





767

ILLUSTRATED TOOL AND EQUIPMENT MANUAL

A71001-191		
QUANTITY	NOMENCLATURE	PART NUMBER
2	BOLT	BACB30US16-21
1	1.0 BALL LOCK PIN	CL-12-BLPL-2.10-S
2	3/4 BALL LOCK PIN	CL-16-BLPL-2.10-S
2	RING	S-643-1
1	STORAGE BOX	

**WEIGHT:** 650 lbs (295 kg)

**DIMENSIONS:** 12 x 30 x 65 inches (305 x 762 x 1651 mm)

**NOTE:** A71001-191 supersedes A71001-185  
A71001-185 supersedes A71001-182

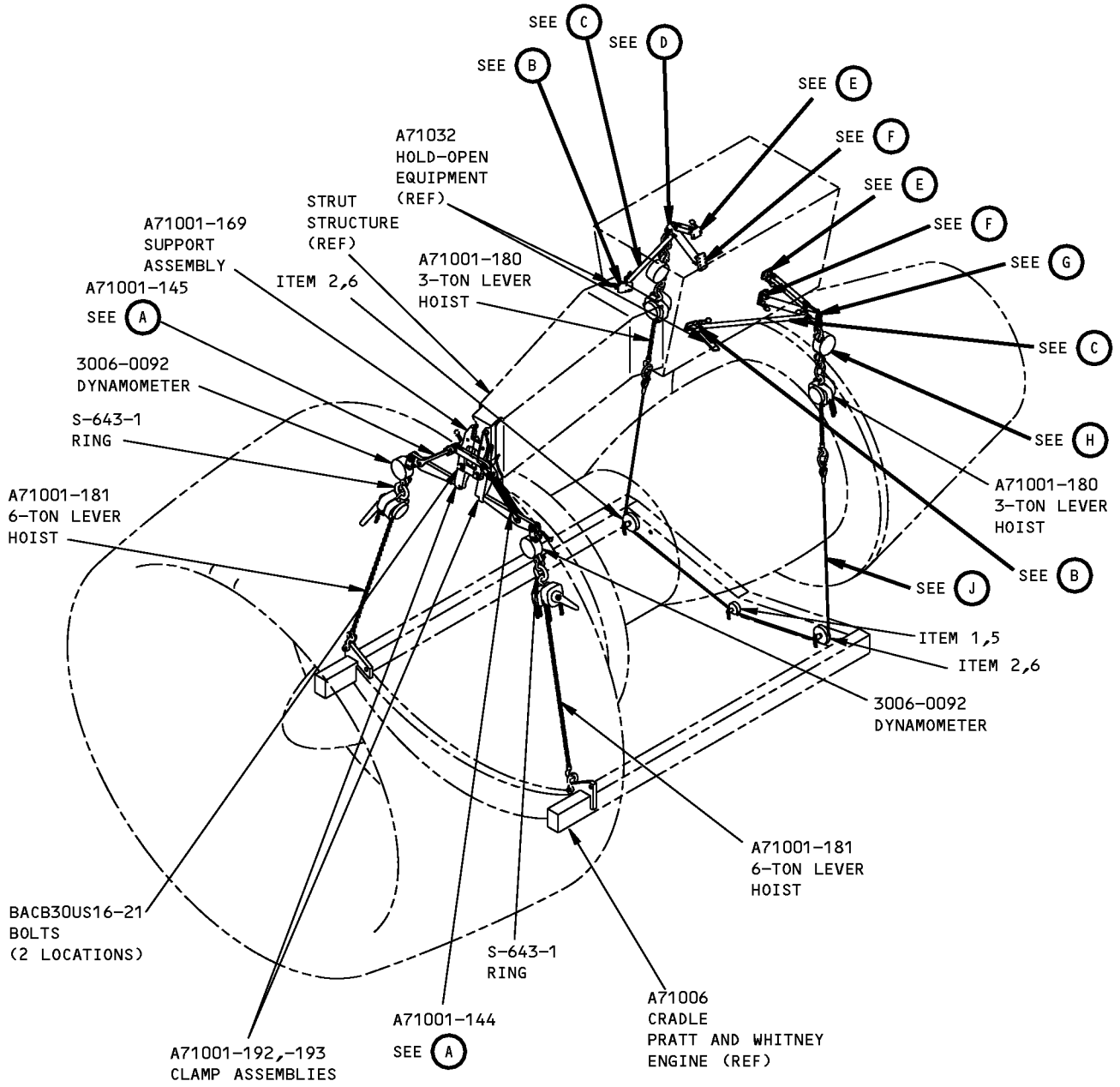

**Pratt and Whitney Engines Bootstrap Equipment  
Figure 1 (Sheet 1 of 6)**

**ILLUSTRATED TOOL AND EQUIPMENT MANUAL**

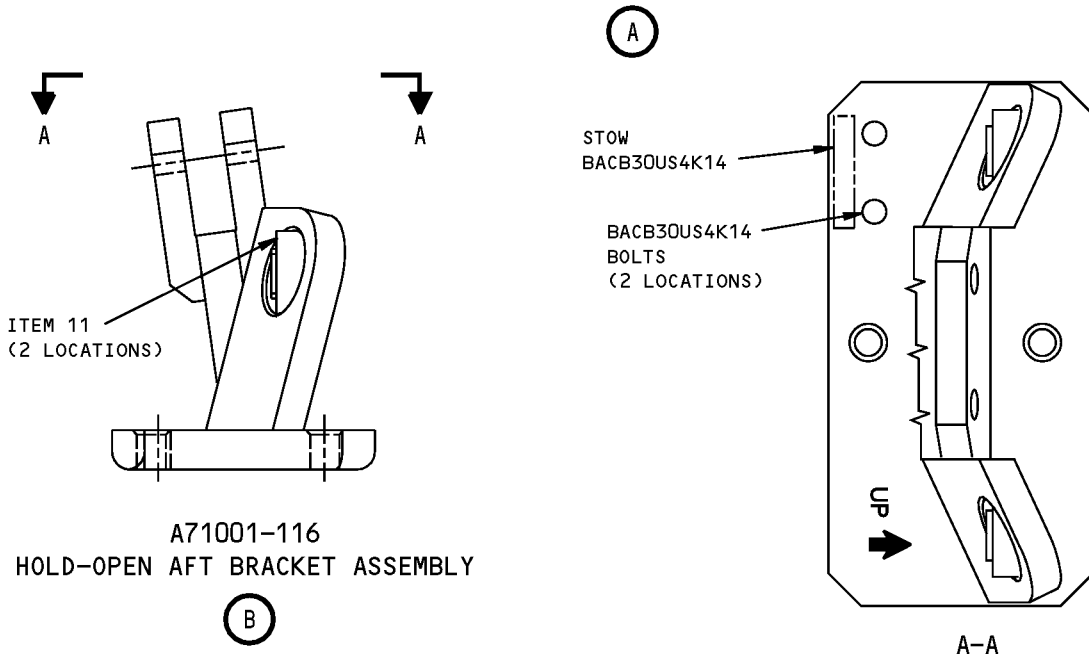
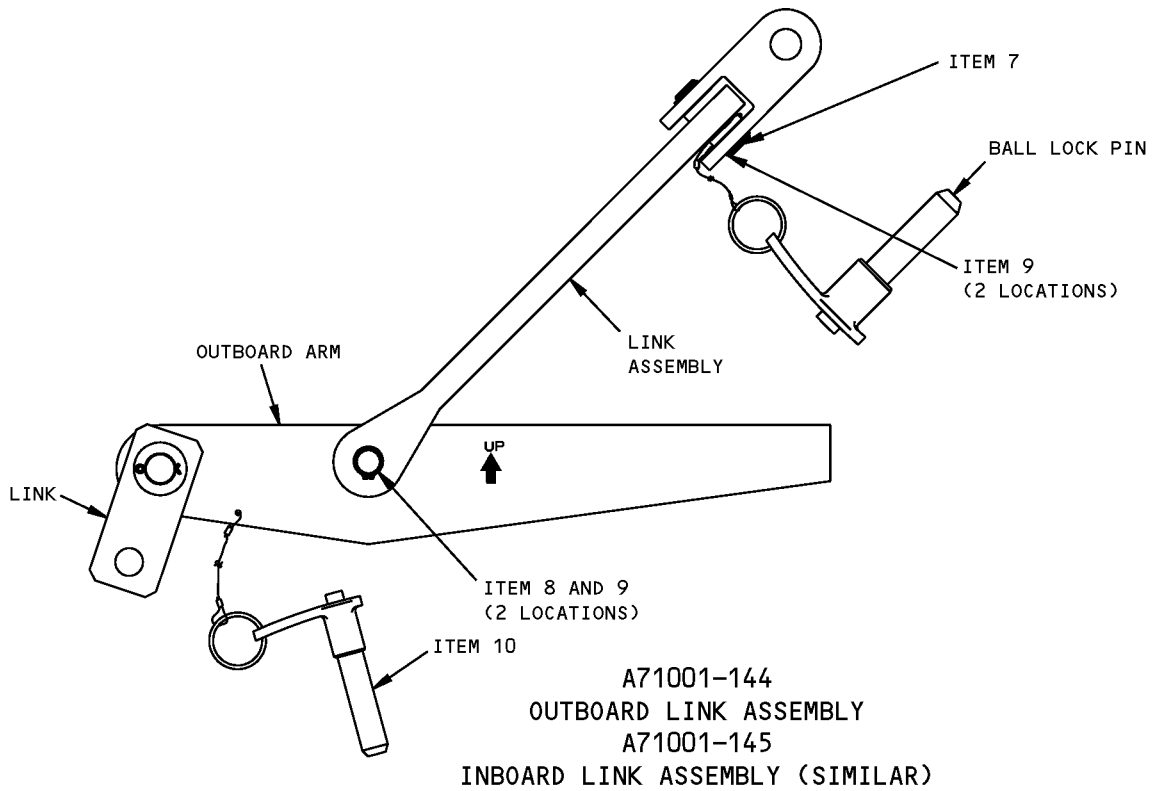

**Pratt and Whitney Engines Bootstrap Equipment  
Figure 1 (Sheet 2 of 6)**

**ILLUSTRATED TOOL AND EQUIPMENT MANUAL**

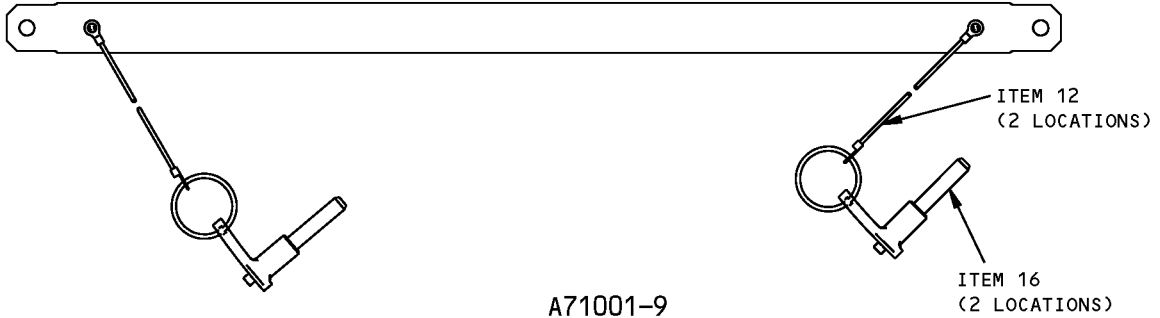

A71001-9  
AFT BRACE ASSEMBLY (INBOARD)  
A71001-10  
OUTBOARD AFT BRACE ASSEMBLY (OUTBOARD)(SIMILAR)

(C)

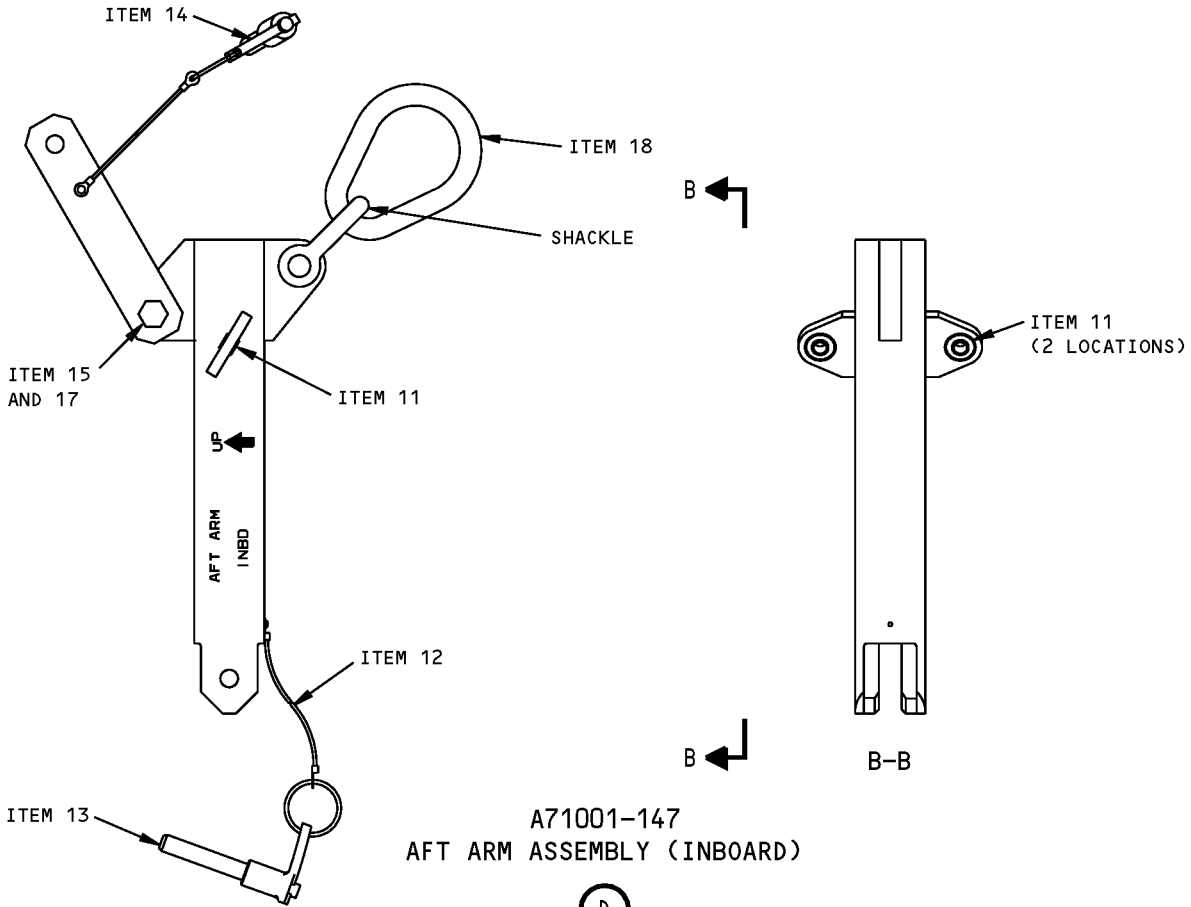

A71001-147  
AFT ARM ASSEMBLY (INBOARD)

(D)

**Pratt and Whitney Engines Bootstrap Equipment  
Figure 1 (Sheet 3 of 6)**

**767  
ILLUSTRATED TOOL AND EQUIPMENT MANUAL**

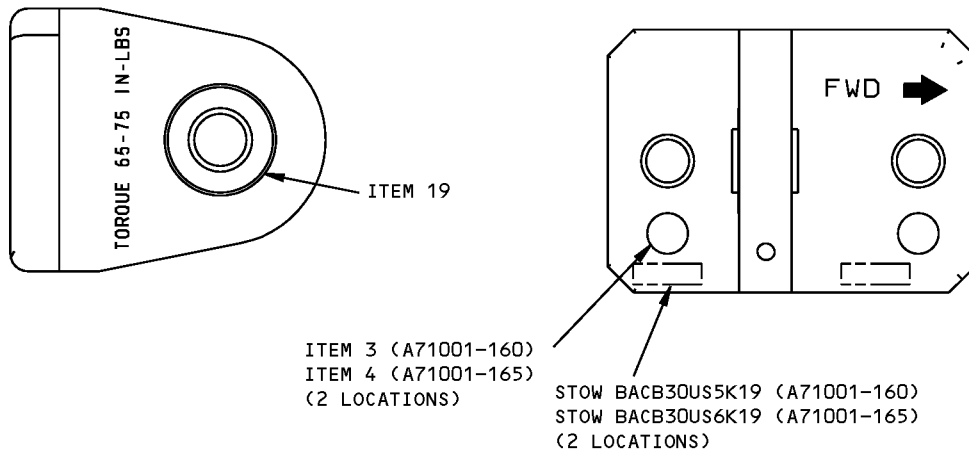

A71001-165  
AFT BRACKET ASSEMBLY (UPPER)  
A71001-160  
AFT BRACKET ASSEMBLY (UPPER) (SIMILAR)

(E)

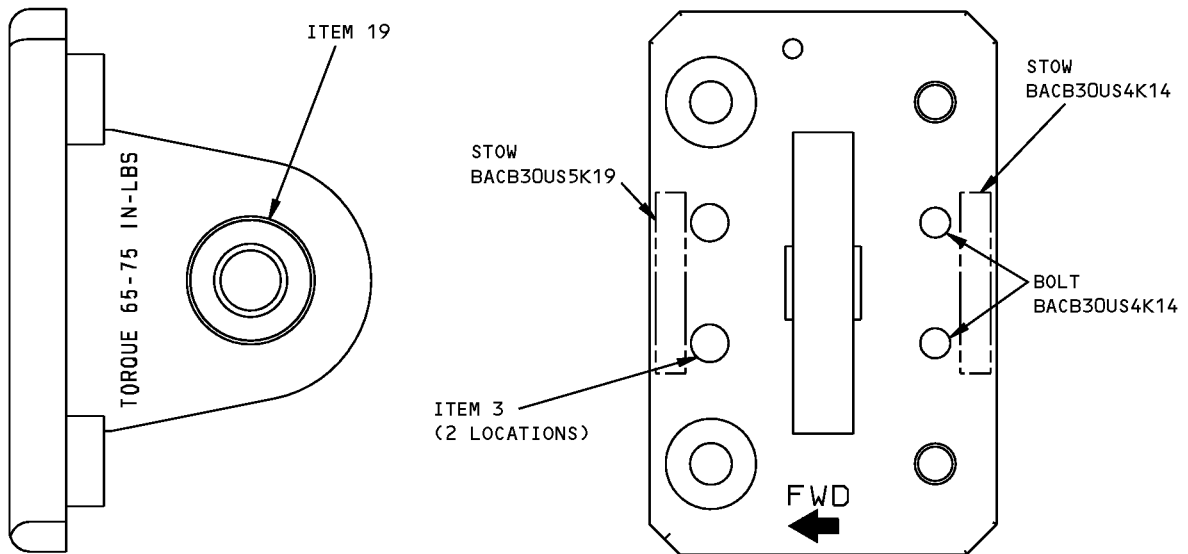

A71001-186  
AFT BRACKET ASSEMBLY (LOWER)

(F)

**Pratt and Whitney Engines Bootstrap Equipment  
Figure 1 (Sheet 4 of 6)**

**ILLUSTRATED TOOL AND EQUIPMENT MANUAL**

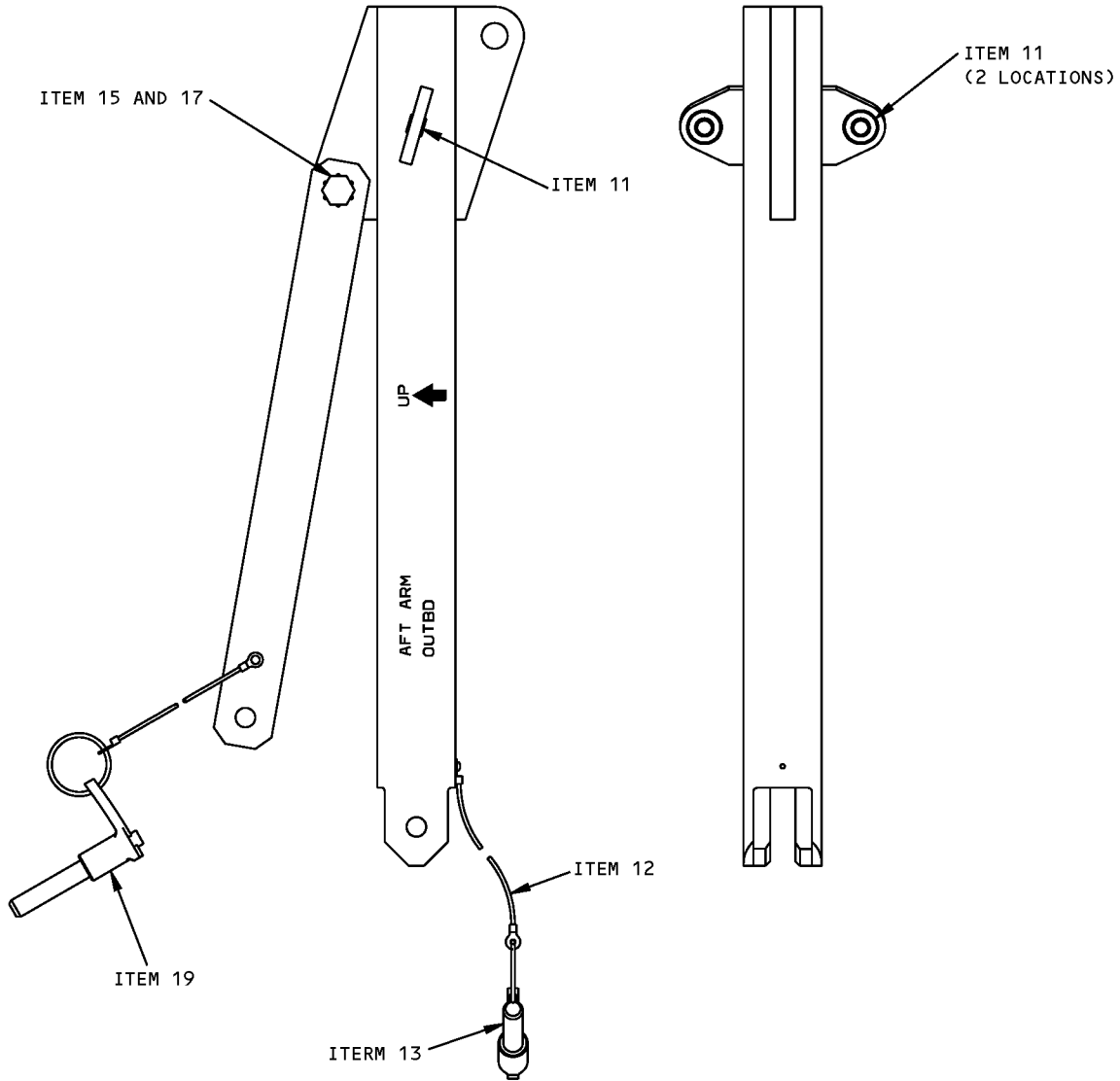

A71001-148  
AFT ARM ASSEMBLY (OUTBOARD)

G

**Pratt and Whitney Engines Bootstrap Equipment  
Figure 1 (Sheet 5 of 6)**

**ILLUSTRATED TOOL AND EQUIPMENT MANUAL**

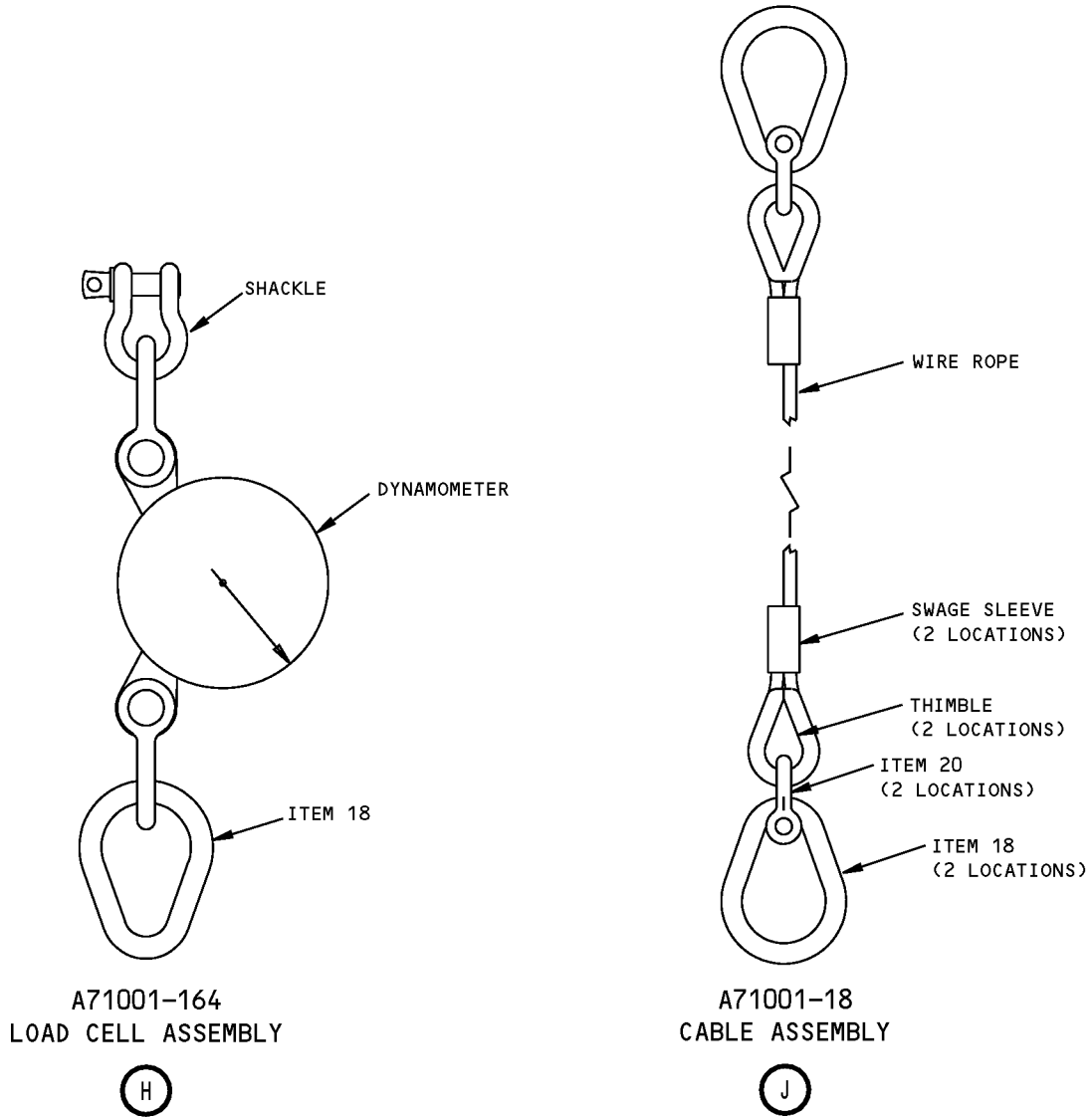

**Pratt and Whitney Engines Bootstrap Equipment  
Figure 1 (Sheet 6 of 6)**



767

ILLUSTRATED TOOL AND EQUIPMENT MANUAL

REPAIRABLE/REPLACEABLE PARTS			
ITEM NO.	PART NO.	NOMENCLATURE	VENDOR CODE
1	A71001-19	4 INCH SHEAVE	
2	A71001-20	6 INCH SHEAVE	
3	BACB30US5K19	BOLT	
4	BACB30US6K19	BOLT	
5	CL-12-BLPL-2.10-S	BALL LOCK PIN	V99862
6	CL-16-BLPL-2.10-S	BALL LOCK PIN	V99862
7	A71001-47	PIN	
8	A71001-46	PIN	
9	5100-75	RETAINING RING	V79136
10	CL-12-BLPL-2.30-S	BALL LOCK PIN	V99862
11	MS14101-6	BEARING	
12	CL-63-KA-10.0-S	CABLE ASSEMBLY	V99862
13	CL-8-BLPL-2.10-S	BALL LOCK PIN	V99862
14	CL-8-BLPL-1.70-S	BALL LOCK PIN	V99862
15	NAS1308-24	BOLT	
16	CL-6-BLPL-1.30-S	BALL LOCK PIN	V99862
17	MS21044N8	LOCK NUT	
18	G-341-5/8	PEAR RING	V75535
19	MS14103-8	BEARING	
20	G-210-7/16	SHACKLE	V75535





767

## ILLUSTRATED TOOL AND EQUIPMENT MANUAL

**PART NUMBER: A71007-27, -39**

**NAME:** PROOF LOAD FIXTURE - BOOTSTRAP, PRATT AND WHITNEY ENGINES, JT9D7R4 AND PW4000

**AIRPLANE MAINTENANCE:** NO

**COMPONENT MAINTENANCE:** YES

**USAGE & DESCRIPTION:** The A71007-27 or -39 proof load fixture is used to proof load the A71001 engine bootstrap, used on 767 airplanes equipped with JT9D-7R4D or PW4000 engines. The only difference between the A71007-27 and -39 is the A71007-39 has an A71001-40 head assembly that is 0.5 inch longer than the A71001-29 head assembly found on A71007-27. Existing parts are satisfactory but may be reworked in accordance with the current A71007 drawing. Refer to the current A71007 and A71001 drawings for complete proof load instructions. A71007 consists of a weldment of structural channel beams, hard points and connecting hardware.

**WEIGHT:** 1,500 lbs (680 kg)

**DIMENSIONS:** 104 x 60 x 83 inches (2642 x 1524 x 2108 mm)

**NOTE:** A71007-27 supersedes A71007-23.  
A71007-39 replaces A71007-27 for future procurement.

**ILLUSTRATED TOOL AND EQUIPMENT MANUAL**

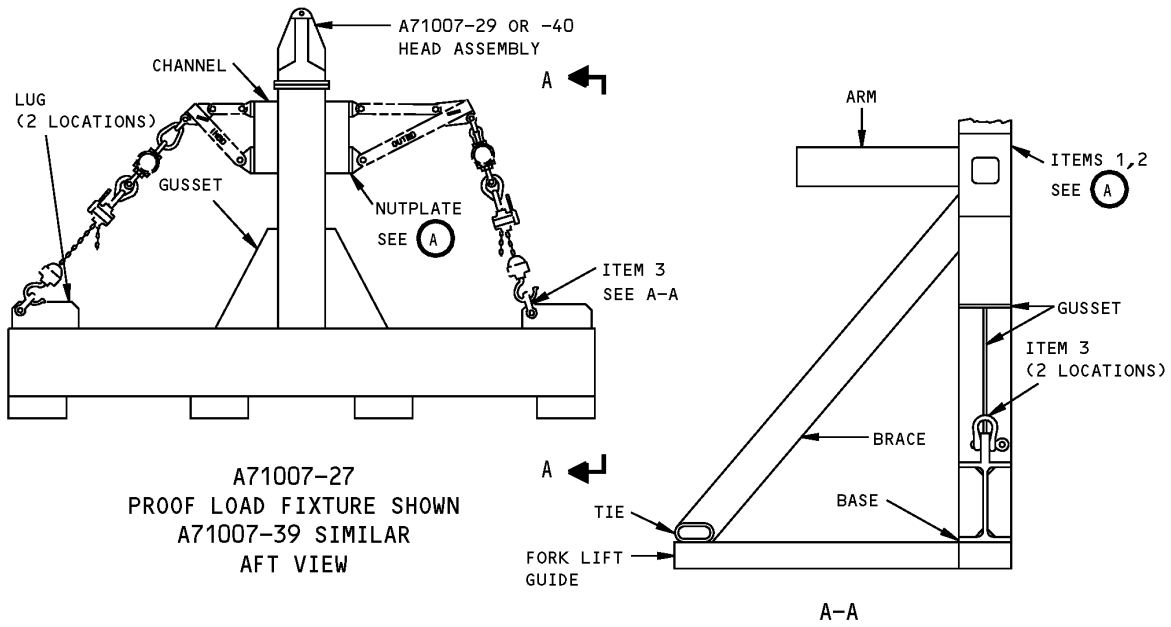

A71007-27  
PROOF LOAD FIXTURE SHOWN  
A71007-39 SIMILAR  
AFT VIEW

**Pratt and Whitney Engines Bootstrap Proof Load Fixture  
Figure 1 (Sheet 1 of 2)**

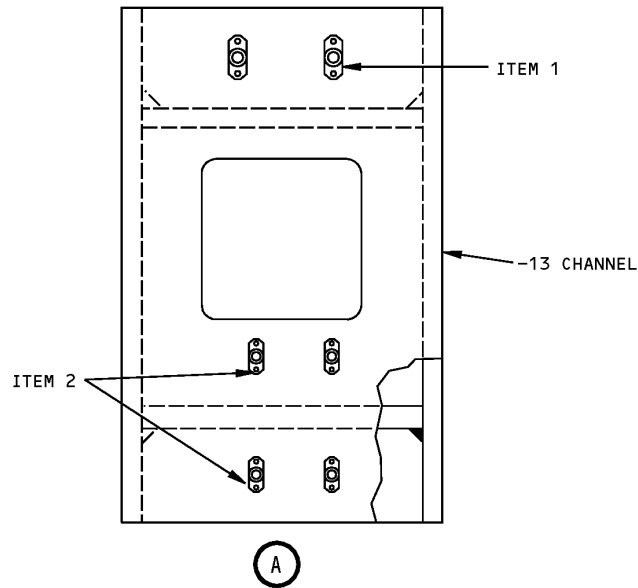

**Pratt and Whitney Engines Bootstrap Proof Load Fixture  
Figure 1 (Sheet 2 of 2)**



767

ILLUSTRATED TOOL AND EQUIPMENT MANUAL

REPAIRABLE/REPLACEABLE PARTS			
ITEM NO.	PART NO.	NOMENCLATURE	VENDOR CODE
1	23605-054	NUTPLATE	V80539
2	13605-048	NUTPLATE	V80539
3	G-209-7/8	SHACKLE	V75535



767

## ILLUSTRATED TOOL AND EQUIPMENT MANUAL

**PART NUMBER: A71008-1, -64, -65**

**NAME:** SLING EQUIPMENT - PRATT AND WHITNEY ENGINE

**AIRPLANE MAINTENANCE:** NO

**COMPONENT MAINTENANCE:** YES

**USAGE & DESCRIPTION:** A71008-1 or A71008-64 sling equipment is used on JT9D-7R4D engines. A71008-65 sling equipment is used on PW4000 engines. A71008 is an overhead sling fixture that handles engine and equipment from the front upper ground handling point on the engine fan case, and adapts for use on either the aft flight mount fitting or the aft flight mount lugs on the engine case. A71008 handles the bare engine, built-up engine and cradle or built-up engine, cradle and stand. It is not necessary to order complete end items for different engines. Conversion and adaptation to a different engine can be accomplished by interchanging front and/or aft fitting assemblies. Refer to the current A71008 drawing for complete usage instructions. The A71008 sling equipment consists of:

A71008-1		
QUANTITY	NOMENCLATURE	PART NUMBER
1	AFT FITTING ASSEMBLY	A71008-34
1	NUT	NAS1021N8
1	BOLT	NAS1308-30
1	MAIN FITTING ASSEMBLY	A71008-35
1	PROOF LOAD TAG	F70308-15
1	IDENTIFICATION TAG	F70308-16

A71008-64		
QUANTITY	NOMENCLATURE	PART NUMBER
1	FRONT FITTING ASSEMBLY	A71008-11
1	BEAM ASSEMBLY	A71008-61
1	AFT FITTING ASSEMBLY	A71008-62
1	STORAGE BOX	

A71008-65		
QUANTITY	NOMENCLATURE	PART NUMBER
1	FRONT FITTING ASSEMBLY	A71008-63
1	BEAM ASSEMBLY	A71008-61
1	AFT FITTING ASSEMBLY	A71008-59



**767**  
**ILLUSTRATED TOOL AND EQUIPMENT MANUAL**

A71008-65		
QUANTITY	NOMENCLATURE	PART NUMBER
1	STORAGE BOX	

**WEIGHT:** 800 lbs (363 kg)

**DIMENSIONS:** 8 x 24 x 100 inches (203 x 610 x 2540 mm)

**NOTE:** A71008-64 replaces A71008-1 for future procurement.

**767  
ILLUSTRATED TOOL AND EQUIPMENT MANUAL**

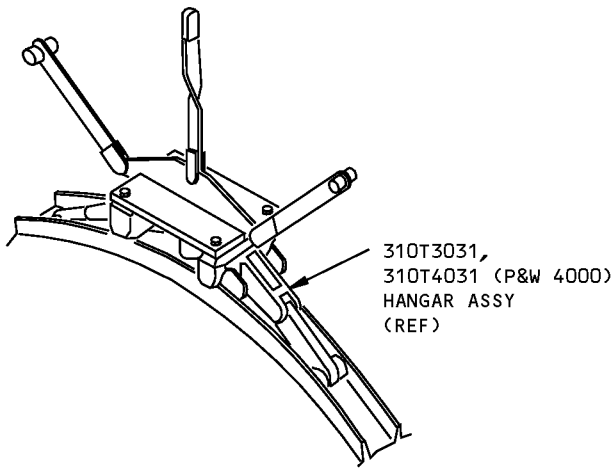
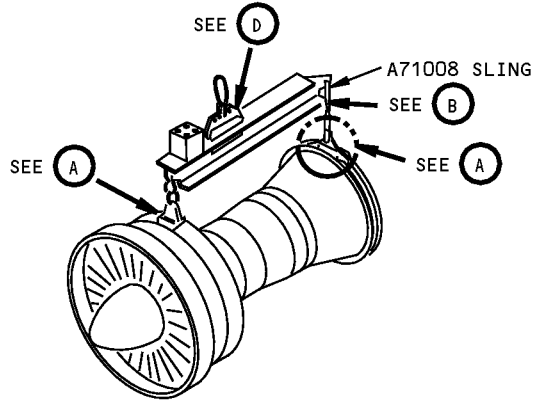

AFT FLIGHT MOUNT FITTING

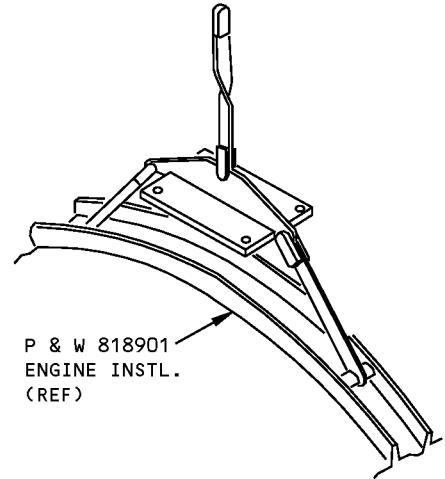

AFT FLIGHT MOUNT LUGS

(A)

**Pratt and Whitney Engines Sling Equipment  
Figure 1 (Sheet 1 of 3)**

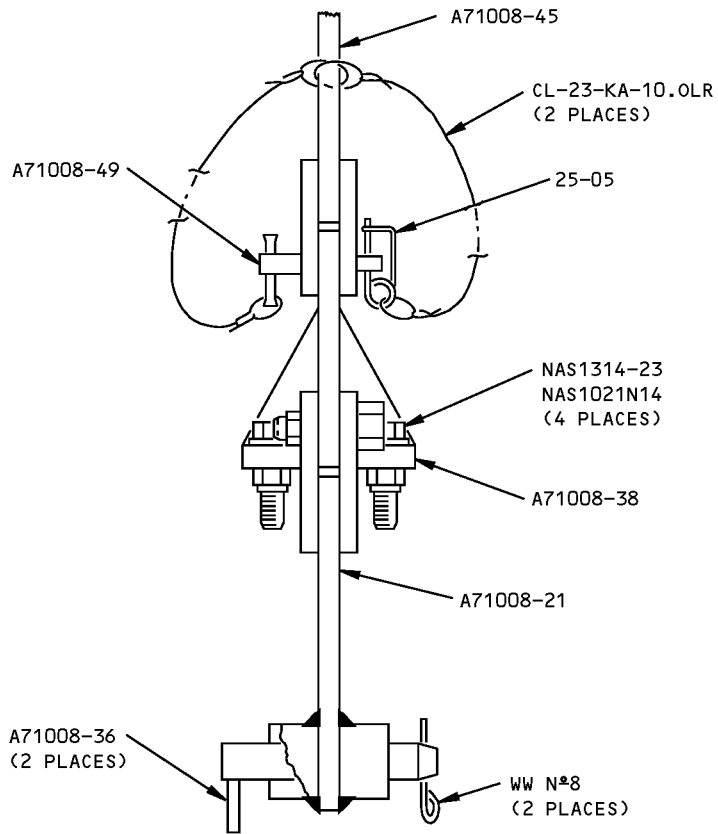

**A71008-65 SLING EQUIPMENT**

**Pratt and Whitney Engines Sling Equipment  
Figure 1 (Sheet 2 of 3)**

**ILLUSTRATED TOOL AND EQUIPMENT MANUAL**

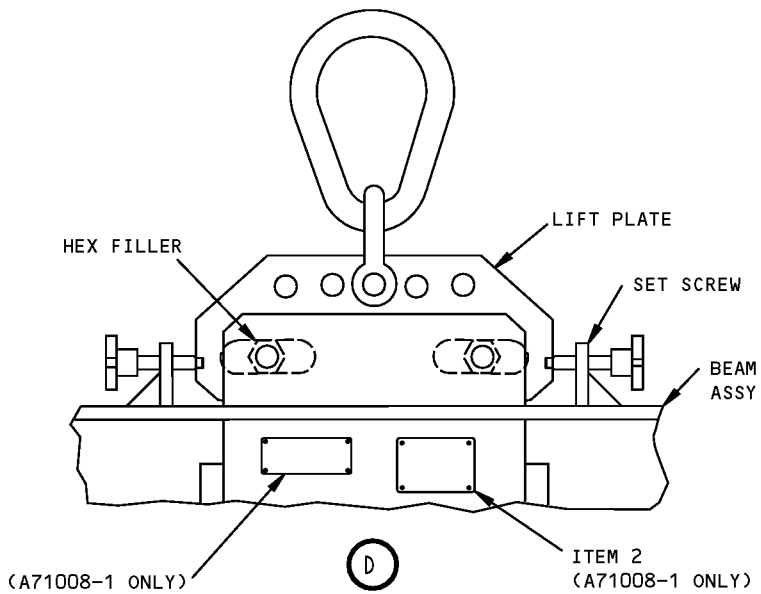
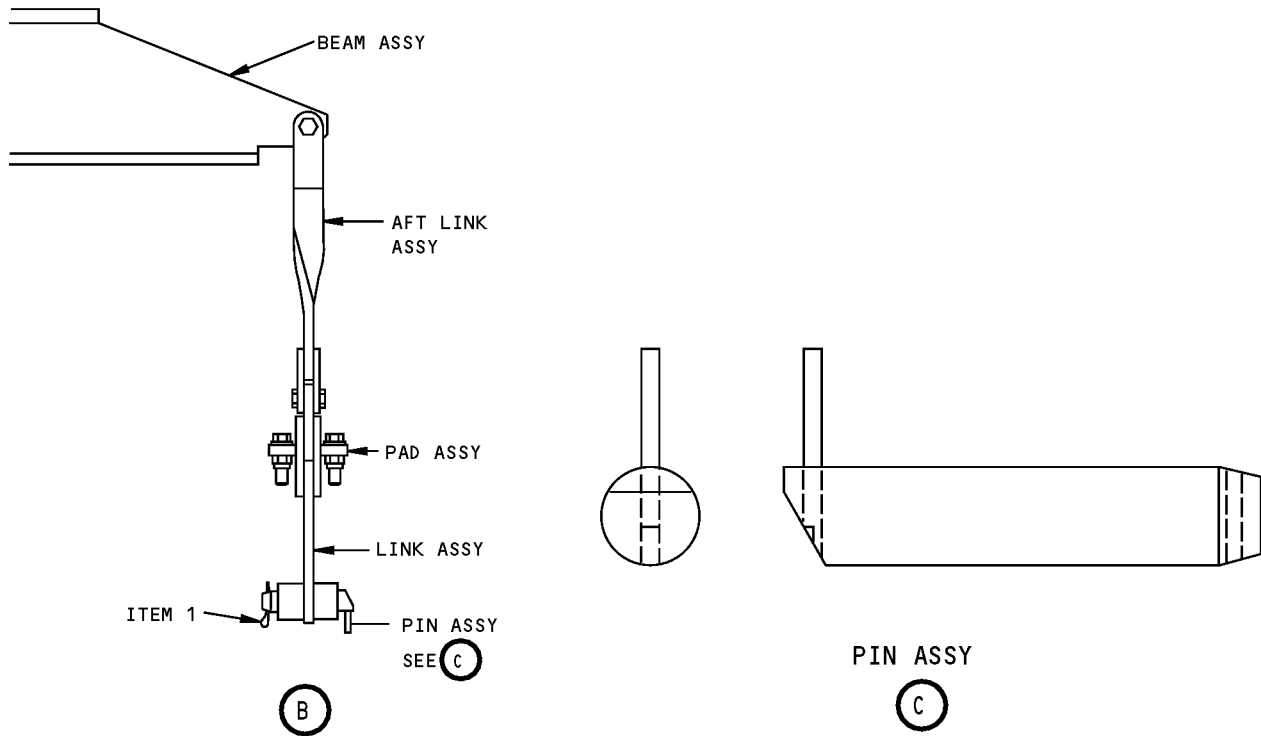

**Pratt and Whitney Engines Sling Equipment  
Figure 1 (Sheet 3 of 3)**





767

ILLUSTRATED TOOL AND EQUIPMENT MANUAL

REPAIRABLE/REPLACEABLE PARTS			
ITEM NO.	PART NO.	NOMENCLATURE	VENDOR CODE
1	WW NO. 8	HAIR PIN	V65029
2	F70308-15	PROOF LOAD TAG	
	A71008-29	HANDLE	



767

**ILLUSTRATED TOOL AND EQUIPMENT MANUAL**

**PART NUMBER: A71012-35**

**NAME:** PROOF LOAD EQUIPMENT - CRADLE, PRATT AND WHITNEY ENGINE

**AIRPLANE MAINTENANCE:** NO

**COMPONENT MAINTENANCE:** YES

**USAGE & DESCRIPTION:** The A71012-35 proof load equipment is used to proof load the A71006 engine cradle, which is used on the JT9D-7R4D engine. Refer to the current A71012 and A71006 drawings for complete usage instructions. A71012-35 consists of a A71012-36 load beam assembly, a A71012-37 front beam assembly, and a A71012-38 aft beam assembly.

**WEIGHT:** 740 lbs (336 kg)

**DIMENSIONS:** 12 x 62 x 100 inches (305 x 1575 x 2540 mm)

**NOTE:** A71012-35 supersedes A71012-1.

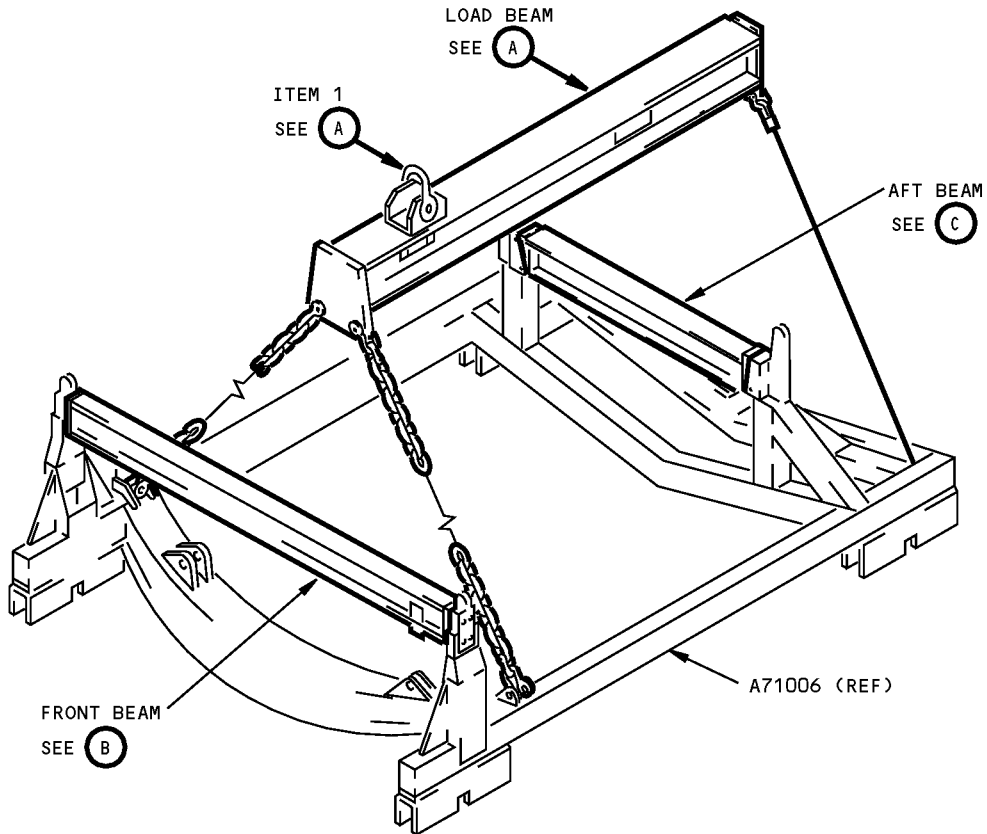

**Pratt and Whitney Engine Cradle Proof Load Equipment  
Figure 1 (Sheet 1 of 2)**

**ILLUSTRATED TOOL AND EQUIPMENT MANUAL**

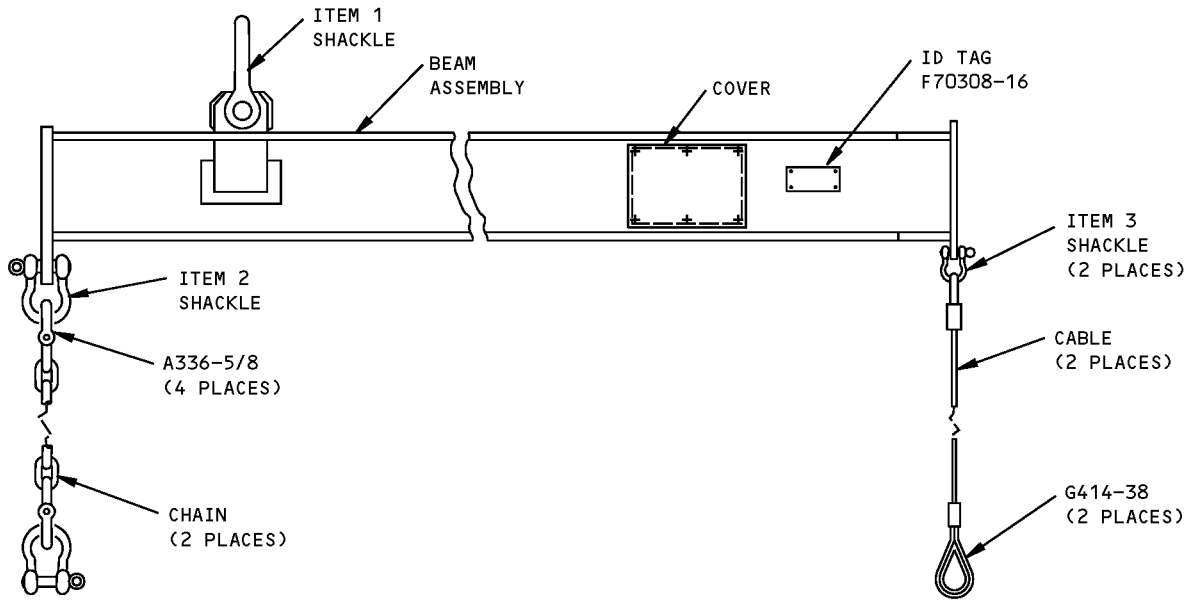

A

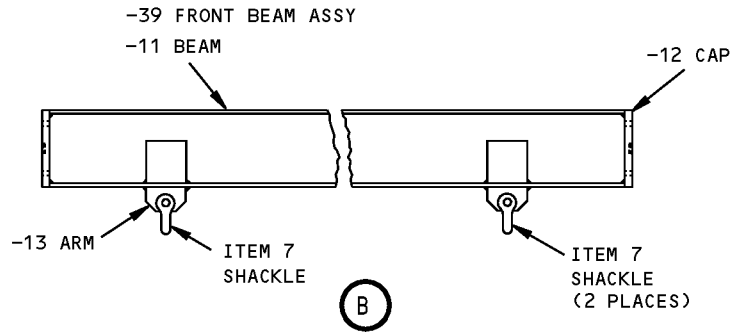

B

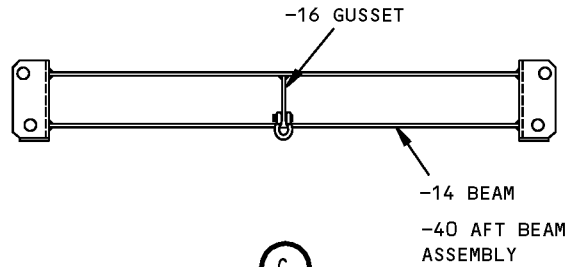

C

**Pratt and Whitney Engine Cradle Proof Load Equipment  
Figure 1 (Sheet 2 of 2)**



767

ILLUSTRATED TOOL AND EQUIPMENT MANUAL

REPAIRABLE/REPLACEABLE PARTS			
ITEM NO.	PART NO.	NOMENCLATURE	VENDOR CODE
1	G-209-1 3/8	SHACKLE	V19691
2	G-209-7/8	SHACKLE	V19691
3	G-209-7/16	SHACKLE	V19691
4	A336-5/8	CONNECTING LINK	V19691
5	MS24665-426	COTTER PIN	
6	MS20392-12C61	PIN	
7	G-209-5/8	SHACKLE	V19691
	G-209-1/2	SHACKLE	V19691



767

## ILLUSTRATED TOOL AND EQUIPMENT MANUAL

**PART NUMBER:** A71013-19, -32, -40, -45, -55, -82, -88

**NAME:** HOIST ADAPTER - INTEGRATED DRIVE GENERATOR

**AIRPLANE MAINTENANCE:** YES

**COMPONENT MAINTENANCE:** NO

**USAGE & DESCRIPTION:** The A71013 hoist adapter is used on all 767 airplanes except 767-400. A combination of an A71015 lift fixture (or acceptable commercial jack) and an A71013 adapter (and possibly an A71013 spacer) is required to remove/install the integrated drive generator (IDG). The A71013-32 and -55 are hoist adapters. The A71013-82 is a hoist adapter assembly. A71013-88 is an adapter assembly. The A71013-19,-40 and -45 are all spacer assemblies. Refer to AMM 24-11-01 and current A71013 drawing for additional instructions.

Information on the A71013 adapter/spacer/ jack/lift fixture compatibility is included below. In addition, with CF6-80A or 80C2B, JT9D-7R4D/E or PW4000 engines the IDG can also be removed with a combination of the A71013-45 spacer assembly and a A71013-88 adapter assembly. Commercial transmission-type jacks can also be used to remove/install a 767 IDG (except 767-400). Commercial jacks that are acceptable are the Lincoln, model B67554; Hein-Warner, model 62; Clore, model W93718,W93720 and W93724. Any of these models require the use of an A71013-19, -40 or -45 spacer and either an A71013-55 or -82 hoist adapter for the CF6-80A or 80C2B, JT9D-7R4D/E or PW4000 engines. To remove the IDG from a Rolls-Royce RB211-524H with the commercial jacks, a A71013-19 spacer is required together with a A71013-32, -55 or -82 hoist adapter.

The A71013-32 and -55 hoist adapters are generally a weldment of a steel plate, a clevis assembly and attached neoprene rubber pad and a nylon strap assembly. The A71013-82 hoist adapter assembly is considerably lighter than the A71013-32 or -55 hoist adapter. The A71013-82 consists of a weldment of aluminum plates, attached neoprene pads and a nylon strap assembly with ratchet. The A71013-88 adapter assembly is a simple welded steel plate and clevis assembly. The A71013-19, -40 and -45 spacer assemblies generally consist of steel weldments and attaching hardware.

**NOTE:** For 767-400 airplanes, refer to A20001 boom hoist, A24011 hoist adapter, and J20002 load positioner.

**WEIGHT:**

- A71013-19 - 12 lbs (5 kg)
- A71013-32 - 30 lbs (14 kg)
- A71013-40 - 20 lbs (9 kg)
- A71013-45 - 26 lbs (12 kg)
- A71013-55 - 30 lbs (14 kg)
- A71013-82 - 9 lbs (4 kg)
- A71013-88 - 14 lbs (6 kg)



767

## ILLUSTRATED TOOL AND EQUIPMENT MANUAL

**DIMENSIONS:**

A71013-19 - 3 x 11 x 12 inches (76 x 279 x 305 mm)  
A71013-32 - 8 x 10 x 17 inches (203 x 254 x 432 mm)  
A71013-40 - 8 x 10 x 16 inches (203 x 254 x 406 mm)  
A71013-45 - 6 x 12 x 14 inches (152 x 305 x 356 mm)  
A71013-55 - 8 x 10 x 17 inches (203 x 254 x 432 mm)  
A71013-82 - 9x 9 x 18 inches (229 x 229 x 457 mm)  
A71013-88 - 2 x 8 x 11 inches (51 x 203 x 279 mm)

**NOTE:**

A71013-82 supersedes A71013-70.  
A71013-82 replaces A71013-55 for future procurement.  
A71013 replaces 2ME65B89603 for future procurement.  
A71013 replaces G24013 for future procurement.

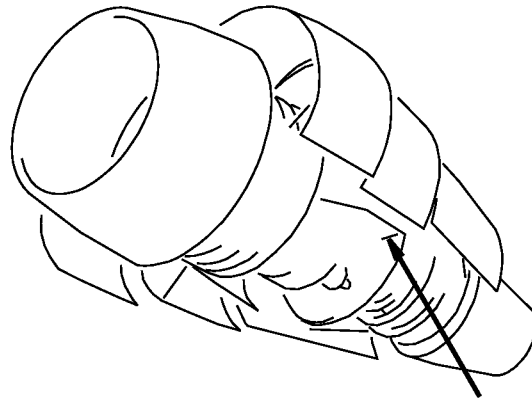

INTEGRATED DRIVE  
GENERATOR (IDG)

SEE (A)

**Integrated Drive Generator Hoist Adapter**  
**Figure 1 (Sheet 1 of 6)**



**767  
ILLUSTRATED TOOL AND EQUIPMENT MANUAL**

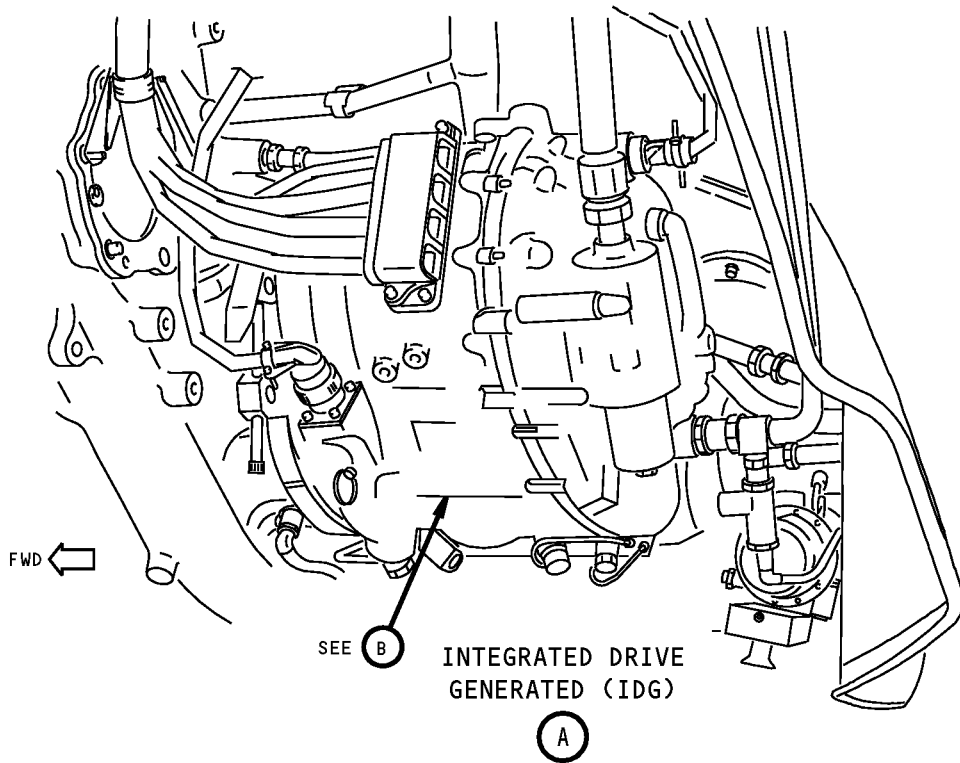

**Integrated Drive Generator Hoist Adapter  
Figure 1 (Sheet 2 of 6)**

**ILLUSTRATED TOOL AND EQUIPMENT MANUAL**

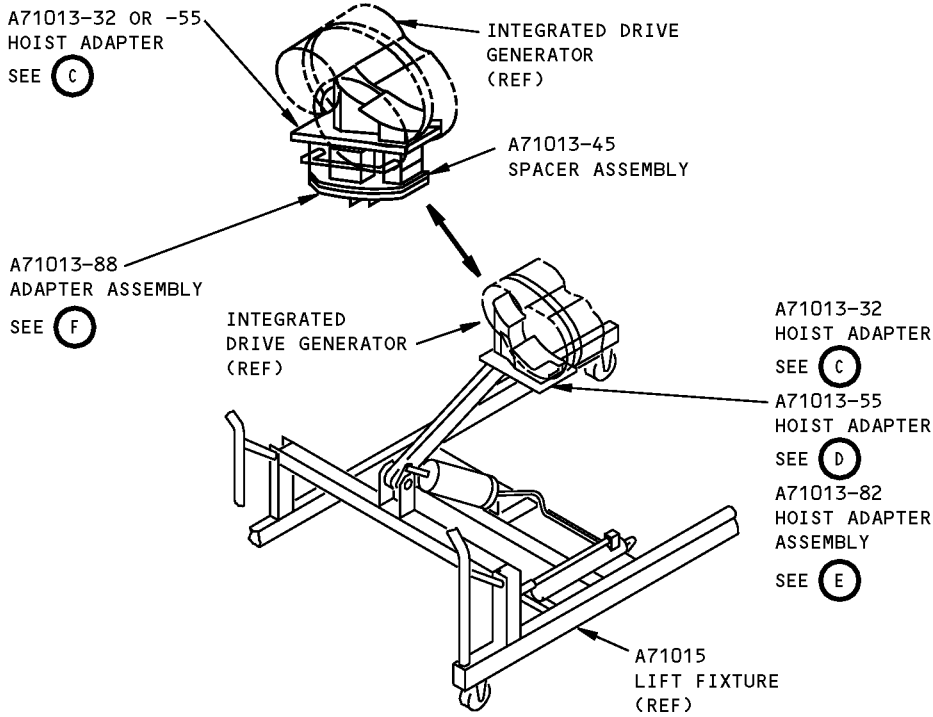

A71013-32, -45, -55, -82, -88

(B)

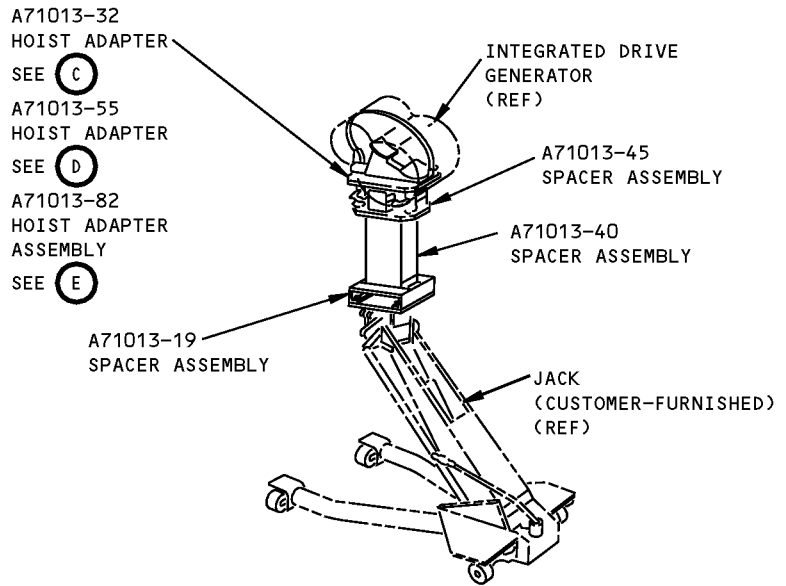

A71013-19, -32, -40, -45, -55, -82

(B)

**Integrated Drive Generator Hoist Adapter  
Figure 1 (Sheet 3 of 6)**

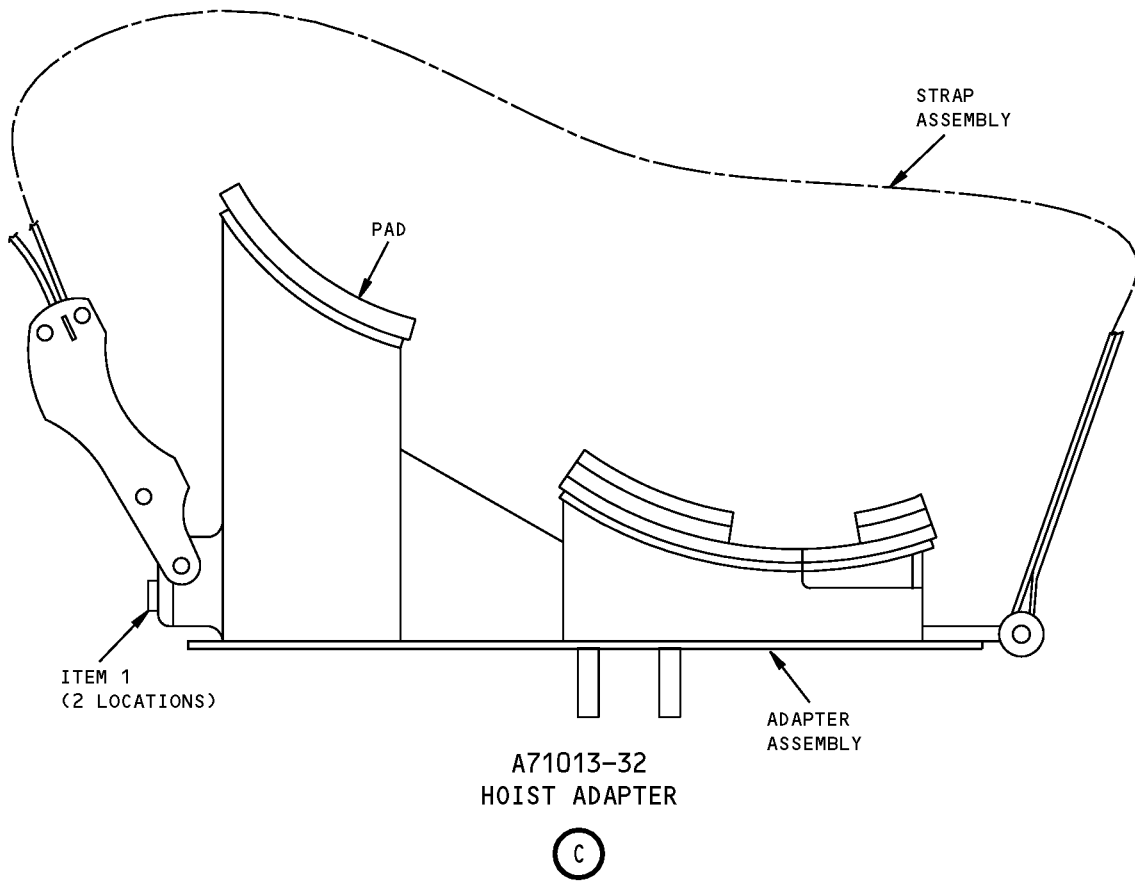

**Integrated Drive Generator Hoist Adapter  
Figure 1 (Sheet 4 of 6)**

**ILLUSTRATED TOOL AND EQUIPMENT MANUAL**

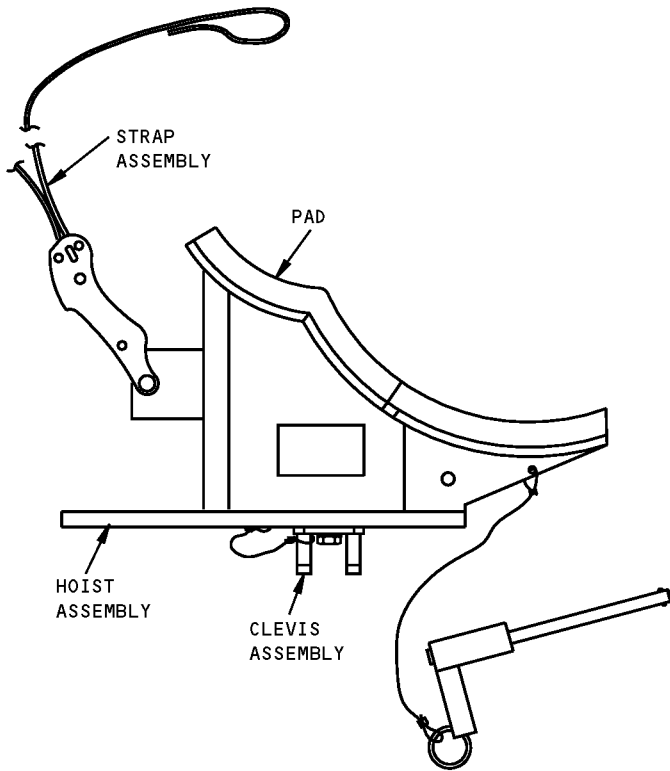

A71013-55  
HOIST ADAPTER

(D)

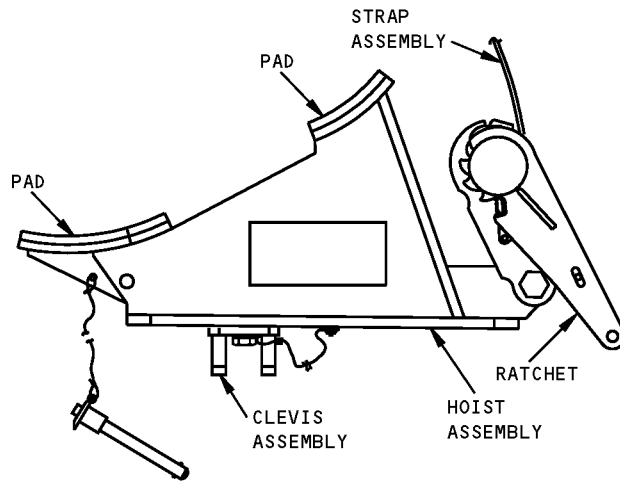

A71013-82  
HOIST ADAPTER ASSEMBLY

(E)

**Integrated Drive Generator Hoist Adapter  
Figure 1 (Sheet 5 of 6)**

**767**  
**ILLUSTRATED TOOL AND EQUIPMENT MANUAL**

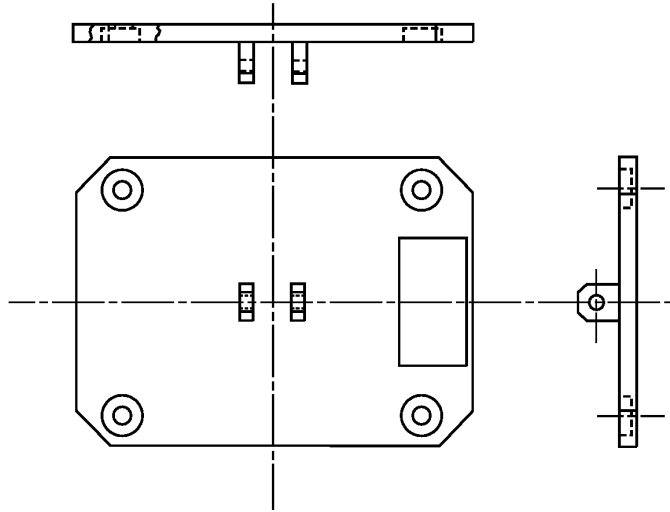

A71013-88  
 ADAPTER ASSEMBLY



**Integrated Drive Generator Hoist Adapter**  
**Figure 1 (Sheet 6 of 6)**

REPAIRABLE/REPLACEABLE PARTS			
ITEM NO.	PART NO.	NOMENCLATURE	VENDOR CODE
1	AN4-5A	BOLT	



767

**ILLUSTRATED TOOL AND EQUIPMENT MANUAL**

**PART NUMBER: A71017-1**

**NAME:** LIFT SLING - CORE COWL

**AIRPLANE MAINTENANCE:** YES

**COMPONENT MAINTENANCE:** NO

**USAGE & DESCRIPTION:** The A71017-1 lift sling is used on 767 airplanes equipped with CF6-80A engines. A71017 is a basic sling component that is used with the A20001-1 hoist and the A71016-3 arm to remove and install the CF6-80A engine core cowl. Refer to AMM 71-11-06 for complete usage instructions. A71017-1 consists of:

<b>A71017-1</b>		
<b>QUANTITY</b>	<b>NOMENCLATURE</b>	<b>PART NUMBER</b>
1	FORWARD SLING ASSEMBLY	A71017-2
1	AFT SLING ASSEMBLY	A71017-3
1	WEB STRAP	A71017-7
1	WEB STRAP	A71017-8
VARIOUS	CONNECTING HARDWARE	
1	STORAGE BOX	

**WEIGHT:** 9 lbs (4 kg)

**DIMENSIONS:** 6 x 12 x 12 inches (152 x 305 x 305 mm)

**ILLUSTRATED TOOL AND EQUIPMENT MANUAL**

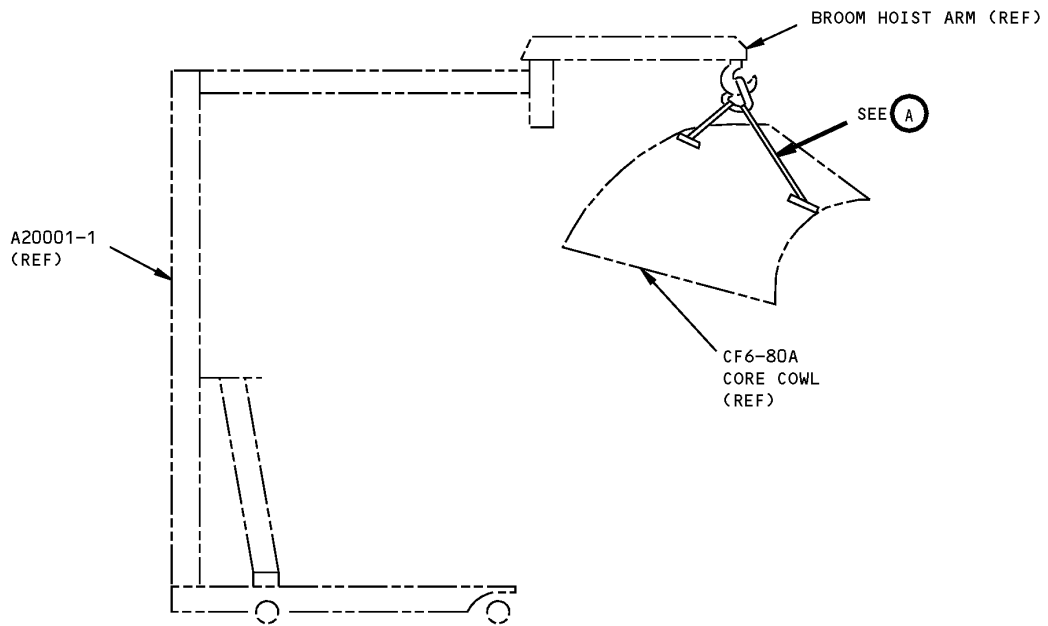

**Core Cowl Lift Sling  
Figure 1 (Sheet 1 of 2)**

**767  
ILLUSTRATED TOOL AND EQUIPMENT MANUAL**

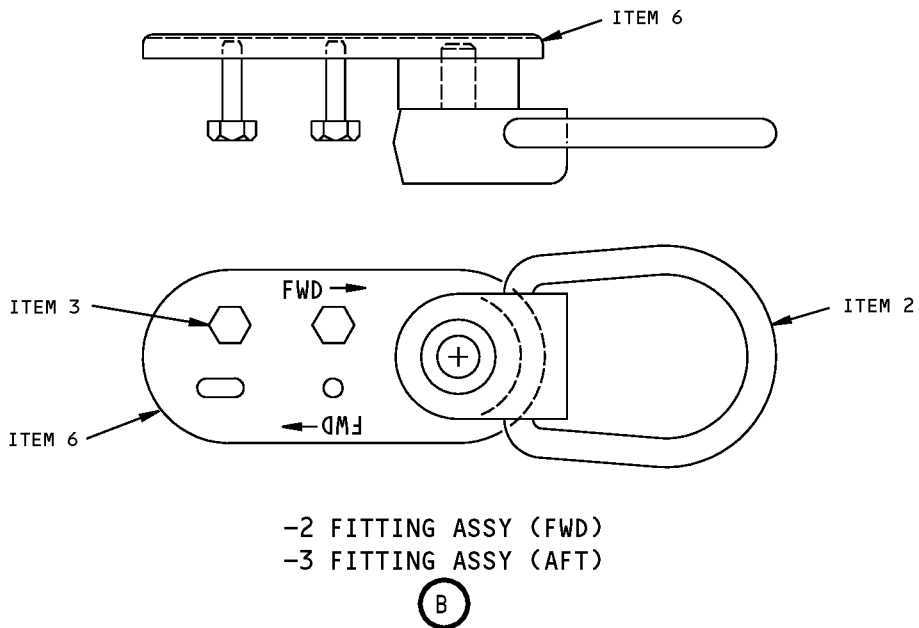
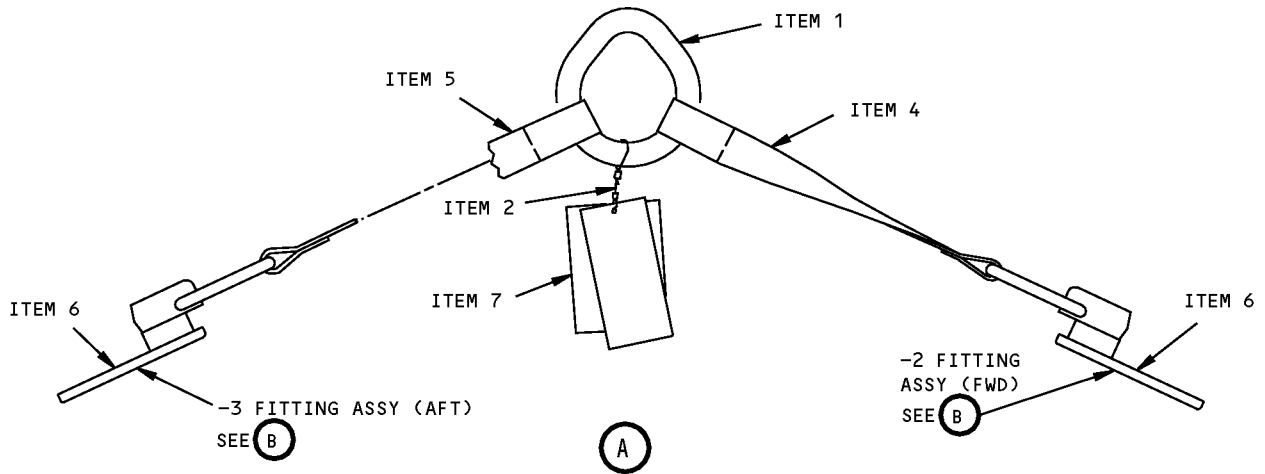

**Core Cowl Lift Sling  
Figure 1 (Sheet 2 of 2)**





767

ILLUSTRATED TOOL AND EQUIPMENT MANUAL

REPAIRABLE/REPLACEABLE PARTS			
ITEM NO.	PART NO.	NOMENCLATURE	VENDOR CODE
1	G-341-5/8	SLING LINK	V75535
2	CL-10-SHR	SAFETY HOIST RING	V99862
3	AN3-6A	HEX HEAD BOLT	
4	A71017-8	WEB STRAP	
5	A71017-7	WEB STRAP	
6	A71017-4	PAD ASSEMBLY	



767

**ILLUSTRATED TOOL AND EQUIPMENT MANUAL**

**PART NUMBER: A71049-1**

**NAME:** PT2 PROBE ADAPTER

**AIRPLANE MAINTENANCE:** YES

**COMPONENT MAINTENANCE:** NO

**USAGE & DESCRIPTION:** The A71049-1 PT2 probe adapter is used on 767 airplanes equipped with PW4000 engines. A71049 is used to facilitate testing of engine pressure and temperature sensor. Refer to AMM 71-00-00 for complete usage instructions. A71049-1 consists of a A71049-2 adapter assembly contained in a storage box.

**WEIGHT:** 2 lbs (0.9 kg)

**DIMENSIONS:** 2 x 3 x 8 inches (51 x 76 x 203 mm)

**767**  
**ILLUSTRATED TOOL AND EQUIPMENT MANUAL**

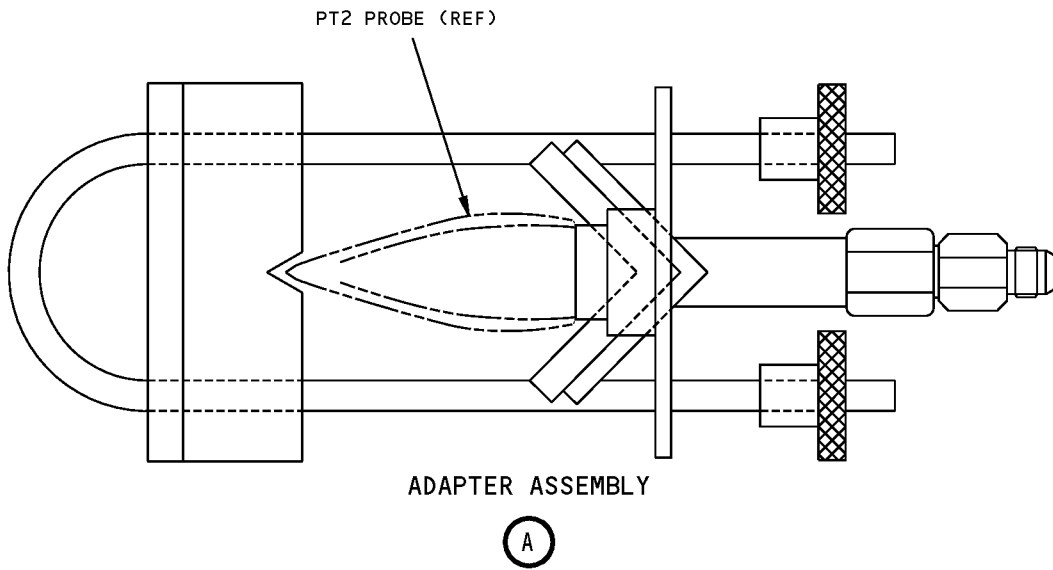
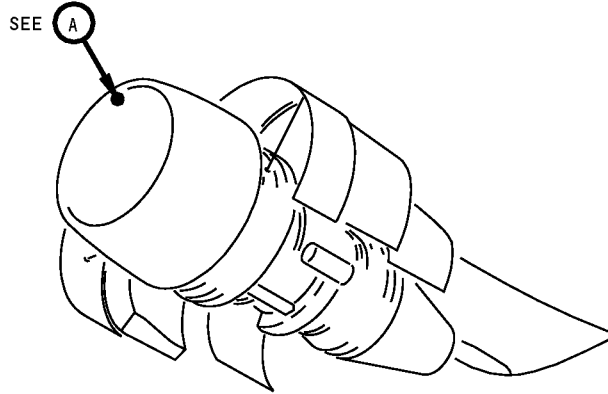

**PT2 Probe Adapter**  
**Figure 1**



767

## ILLUSTRATED TOOL AND EQUIPMENT MANUAL

**PART NUMBER:** A71003-25, -41, -53, -54

**NAME:** TORQUE EQUIPMENT - ENGINE MOUNTS, JT9D-7R4D AND PW4000 ENGINES

**AIRPLANE MAINTENANCE:** YES

**COMPONENT MAINTENANCE:** NO

**USAGE & DESCRIPTION:** The A71003-25 or -53 torque equipment is used on 767 airplanes equipped with Pratt and Whitney JT9D-7R4D or PW4000 engines. The A71003-25 or -53 is applicable to airplanes without vibration isolation mounts, prior to line number 304, that have not incorporated SB 71-0048. The A71003-41 or -54 torque equipment is used on 767 airplanes equipped with Pratt and Whitney 4000 engines. The A71003-41 or -54 is applicable to airplanes with vibration isolation mount, line number 304 and on, (PRRB11480-73) or those that have incorporated SB 71-0048. A71003 is used to adjust and torque the JT9D-7R4D or PW4000 engine mount bolts during an engine change. Refer to AMM 71-00-02 for complete usage instructions. The A71003-25, -41, -53 and -54 consist of:

A71003-25		
QUANTITY	NOMENCLATURE	PART NUMBER
1	FORWARD ADAPTER ASSEMBLY	A71003-2
1	AFT ADAPTER ASSEMBLY	A71003-11
1	12 POINT DEEP SOCKET	13-330
1	STORAGE BOX	

A71003-41		
QUANTITY	NOMENCLATURE	PART NUMBER
1	FORWARD ADAPTER ASSEMBLY	A71003-2
1	AFT ADAPTER ASSEMBLY	A71003-42
1	DEEP SOCKET	A71003-36
1	12 POINT DEEP SOCKET	13-330
1	STORAGE BOX	

A71003-53		
QUANTITY	NOMENCLATURE	PART NUMBER
1	FORWARD ADAPTER ASSEMBLY	A71003-55
1	AFT ADAPTER ASSEMBLY	A71003-11
1	12 POINT DEEP SOCKET	13-330
1	STORAGE BOX	



**767**  
**ILLUSTRATED TOOL AND EQUIPMENT MANUAL**

<b>A71003-54</b>		
<b>QUANTITY</b>	<b>NOMENCLATURE</b>	<b>PART NUMBER</b>
1	FORWARD ADAPTER ASSEMBLY	A71003-55
1	AFT ADAPTER ASSEMBLY	A71003-42
1	DEEP SOCKET	A71003-36
1	12 POINT DEEP SOCKET	13-330
1	STORAGE BOX	

**WEIGHT:** A71003-25 - 6 lbs (3 kg)  
A71003-41 - 5 lbs (2 kg)  
A71003-53 - 6 lbs (3 kg)  
A71003-54 - 6 lbs (3 kg)

**DIMENSIONS:** A71003-25 - 3 x 6 x 9 inches (76 x 152 x 229 mm)  
A71003-41 - 2 x 4 x 13 inches (51 x 102 x 330 mm)  
A71003-53 - 3 x 6 x 9 inches (76 x 152 x 229 mm)  
A71003-54 - 2 x 4 x 13 inches (51 x 102 x 330 mm)

**NOTE:** A71003-53 and -54 replace A71003-25 and -41 respectively for future procurement.  
A71003-41 supersedes A71003-26.

**ILLUSTRATED TOOL AND EQUIPMENT MANUAL**

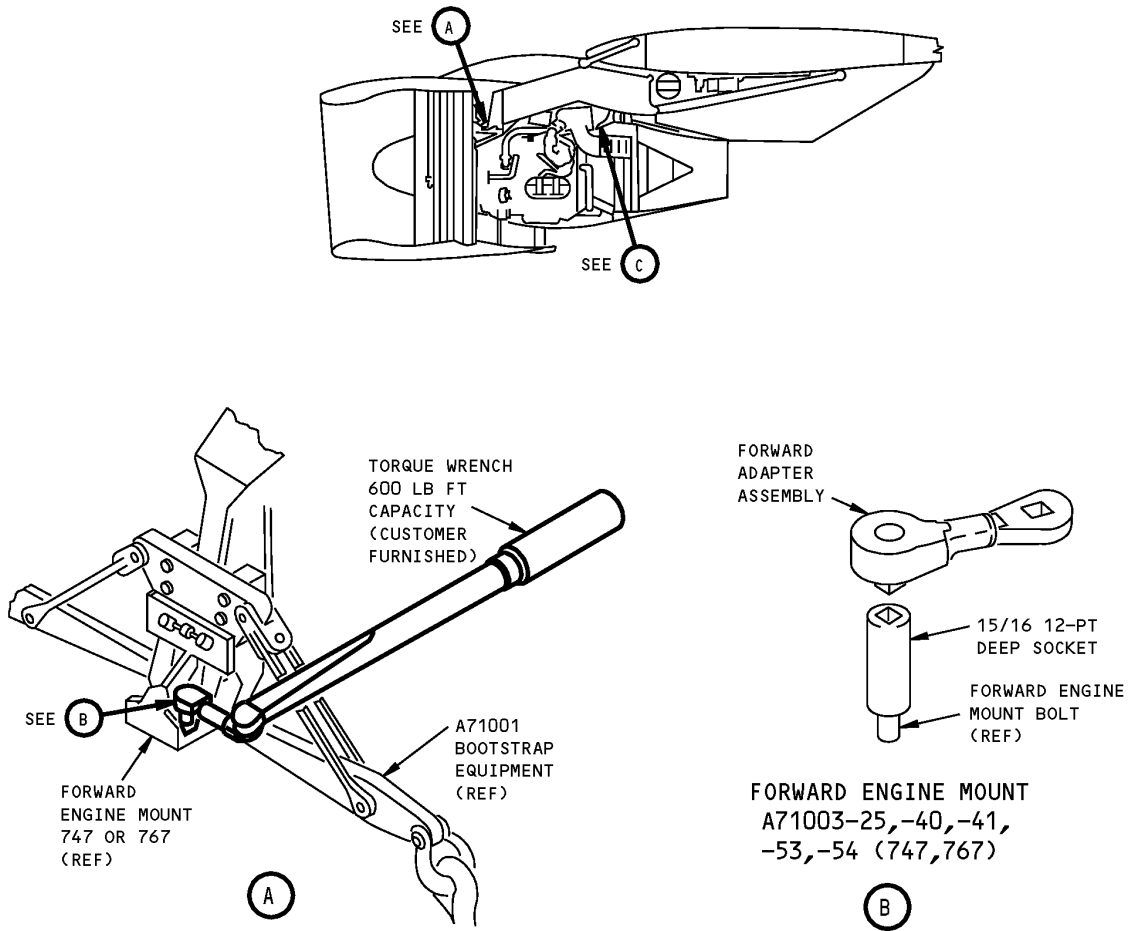

**JT9D-7R4D and PW4000 Engine Mounts Torque Equipment  
Figure 1 (Sheet 1 of 2)**

**767  
ILLUSTRATED TOOL AND EQUIPMENT MANUAL**

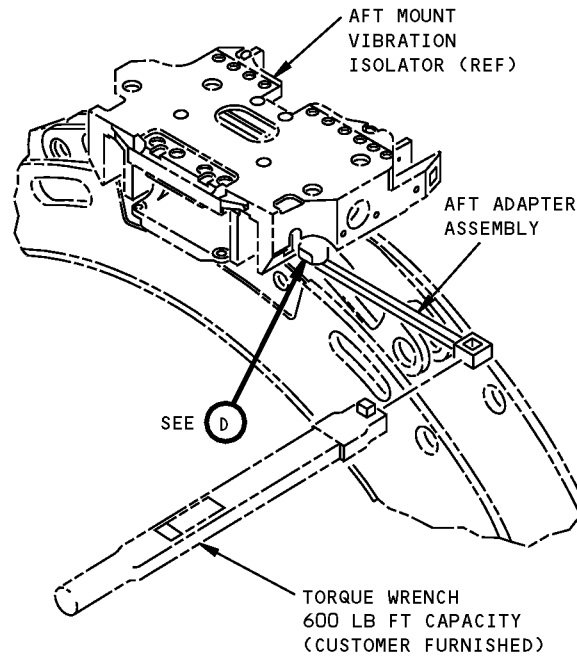

**AFT ENGINE MOUNT  
A71003-41,-54 (767 ONLY)**



(C)

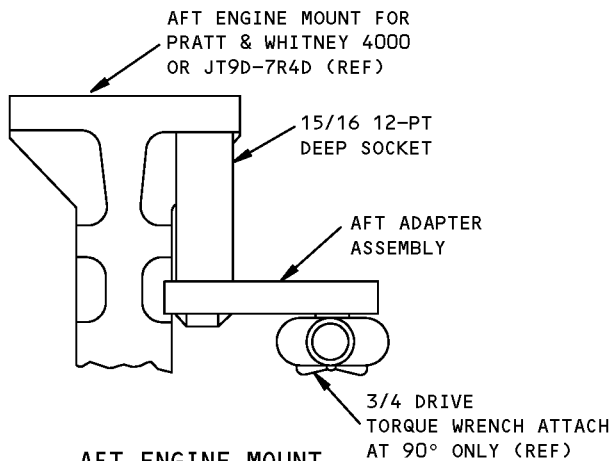

**AFT ENGINE MOUNT  
A71003-25,-53 (767 ONLY)**

(C)

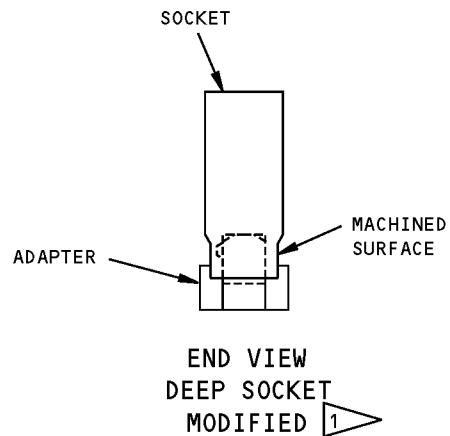

(D)

**JT9D-7R4D and PW4000 Engine Mounts Torque Equipment  
Figure 1 (Sheet 2 of 2)**



767

## ILLUSTRATED TOOL AND EQUIPMENT MANUAL

**PART NUMBER: A71011-262, -263**

**NAME:** BOOTSTRAP EQUIPMENT - GENERAL ELECTRIC ENGINE

**AIRPLANE MAINTENANCE:** YES

**COMPONENT MAINTENANCE:** NO

**USAGE & DESCRIPTION:** The A71011-262 bootstrap equipment is used on 767 airplanes equipped with CF6-80A engines. The A71011-263 bootstrap equipment is used on 767 airplanes equipped with CF6-80C2B engines. The A71011-262 is used in conjunction with the A71023 engine cradle, A78001 thrust reverser hold open equipment-40 knot, A71033 core cowl hold open equipment-40 Knot, A71026 fan cowl hold open equipment-20 knot, or A71027 fan cowl hold open equipment -20 knot to remove and install CF6-80A engine. The A71011-263 is used in conjunction with G71002 engine cradle, G78002 thrust reverser hold open equipment-40 knot to remove and install CF6-80C2B engine. Refer to AMM 71-00-02, 767 CF6-80A Engine Ground Handling Document (EGH), 747/767 CF6-80C2B EGH, and current A71011 drawing for additional usage instructions. The A71011-262 or -263 consists of the following:

A71011-262		
QUANTITY	NOMENCLATURE	PART NUMBER
1	LOAD CELL ASSEMBLY	A71011-16
1	4 INCH SHEAVE	A71011-18
2	6 INCH SHEAVE	A71011-19
1	OUTBOARD LINK ASSEMBLY	A71011-93
1	INBOARD LINK ASSEMBLY	A71011-94
1	CABLE ASSEMBLY	A71011-101
1	GUIDE ASSEMBLY	A71011-119
1	AFT OUTBOARD BRACE ASSEMBLY	A71011-149
1	AFT INBOARD BRACE ASSEMBLY	A71011-150
1	FORWARD SUPPORT ASSEMBLY	A71011-184
2	AFT HOIST	A71011-264
1	OUTBOARD ARM ASSEMBLY	A71011-203
1	INBOARD ARM ASSEMBLY	A71011-204
1	AFT LOWER BRACKET ASSEMBLY - LEFT HAND	A71011-245 <sup>[1]</sup>
1	AFT LOWER BRACKET ASSEMBLY - RIGHT HAND	A71011-246 <sup>[1]</sup>
2	FORWARD HOIST	A71011-265
1	FORWARD BRACKET ASSEMBLY - LEFT HAND	A71011-247 <sup>[1]</sup>
1	FORWARD BRACKET ASSEMBLY - RIGHT HAND	A71011-248 <sup>[1]</sup>





767

## ILLUSTRATED TOOL AND EQUIPMENT MANUAL

A71011-262		
QUANTITY	NOMENCLATURE	PART NUMBER
1	AFT UPPER BRACKET ASSEMBLY - LEFT HAND	A71011-249 <sup>[1]</sup>
1	AFT UPPER BRACKET ASSEMBLY - RIGHT HAND	A71011-250 <sup>[1]</sup>
1	PIVOT FOOT ASSEMBLY	A71011-251 <sup>[1]</sup>
1	PIVOT FOOT ASSEMBLY (OPPOSITE A71011-251)	A71011-252 <sup>[1]</sup>
1	BALL LOCK PIN	NAS1341C5C21D
2	BALL LOCK PIN	NAS1343C5C21D
2	DYNAMOMETER	30006-0092
2	RING	S-643-1
1	AFT LOWER BRACKET ASSEMBLY - LEFT HAND	A71011-185
1	AFT LOWER BRACKET ASSEMBLY - RIGHT HAND	A71011-186
1	AFT UPPER BRACKET ASSEMBLY - LEFT HAND	A71011-195
1	AFT UPPER BRACKET ASSEMBLY - RIGHT HAND	A71011-196
1	FORWARD BRACKET ASSEMBLY - LEFT HAND	A71011-214
1	FORWARD BRACKET ASSEMBLY - RIGHT HAND	A71011-215
1	STORAGE BOX	

\*[1] 767 AIRPLANES INCORPORATING SB 767-54-0033 OR PRR B111827-2

A71011-263		
QUANTITY	NOMENCLATURE	PART NUMBER
1	LOAD CELL ASSEMBLY	A71011-16
2	6 INCH SHEAVE	A71011-166
1	CLAMP ASSEMBLY	A71011-172
1	CLAMP ASSEMBLY (OPPOSITE A71011-173)	A71011-173
1	CABLE ASSEMBLY	A71011-101
1	AFT OUTBOARD BRACE ASSEMBLY	A71011-149
1	AFT INBOARD BRACE ASSEMBLY	A71011-150
1	FORWARD SUPPORT ASSEMBLY	A71011-164
2	AFT HOIST	A71011-264
1	OUTBOARD ARM ASSEMBLY	A71011-203
1	INBOARD ARM ASSEMBLY	A71011-204
1	TORQUE ADAPTER ASSEMBLY	A71011-238
1	AFT LOWER BRACKET ASSEMBLY - LEFT HAND	A71011-245 <sup>[1]</sup>
1	AFT LOWER BRACKET ASSEMBLY - RIGHT HAND	A71011-246 <sup>[1]</sup>



767

ILLUSTRATED TOOL AND EQUIPMENT MANUAL

A71011-263		
QUANTITY	NOMENCLATURE	PART NUMBER
2	FORWARD HOIST	A71011-265
1	FORWARD BRACKET ASSEMBLY - LEFT HAND	A71011-247 <sup>*[1]</sup>
1	FORWARD BRACKET ASSEMBLY - RIGHT HAND	A71011-248 <sup>*[1]</sup>
1	AFT UPPER BRACKET ASSEMBLY - LEFT HAND	A71011-249 <sup>*[1]</sup>
1	AFT UPPER BRACKET ASSEMBLY - RIGHT HAND	A71011-250 <sup>*[1]</sup>
1	PIVOT FOOT ASSEMBLY	A71011-251 <sup>*[1]</sup>
1	PIVOT FOOT ASSEMBLY (OPPOSITE A71011-251)	A71011-252 <sup>*[1]</sup>
1	BALL LOCK PIN	NAS1341C5C21D
2	BALL LOCK PIN	NAS1343C5C21D
2	DYNAMOMETER	30006-0092
2	RING	S-643-1
1	AFT LOWER BRACKET ASSEMBLY - LEFT HAND	A71011-185
1	AFT LOWER BRACKET ASSEMBLY - RIGHT HAND	A71011-186
1	AFT UPPER BRACKET ASSEMBLY - LEFT HAND	A71011-195
1	AFT UPPER BRACKET ASSEMBLY - RIGHT HAND	A71011-196
1	FORWARD BRACKET ASSEMBLY - LEFT HAND	A71011-214
1	FORWARD BRACKET ASSEMBLY - RIGHT HAND	A71011-215
1	STORAGE BOX	

\*[1] 767 AIRPLANES INCORPORATING SB 767-54-0033 OR PRR B111827-2

**WEIGHT:** 185 lbs (84 kg)

**DIMENSIONS:** 15 x 36 x 72 inches (381 x 914 x 1829 mm)

**NOTE:** A71011-262 supersedes A71011-242.  
A71011-263 supersedes A71011-243.

**ILLUSTRATED TOOL AND EQUIPMENT MANUAL**

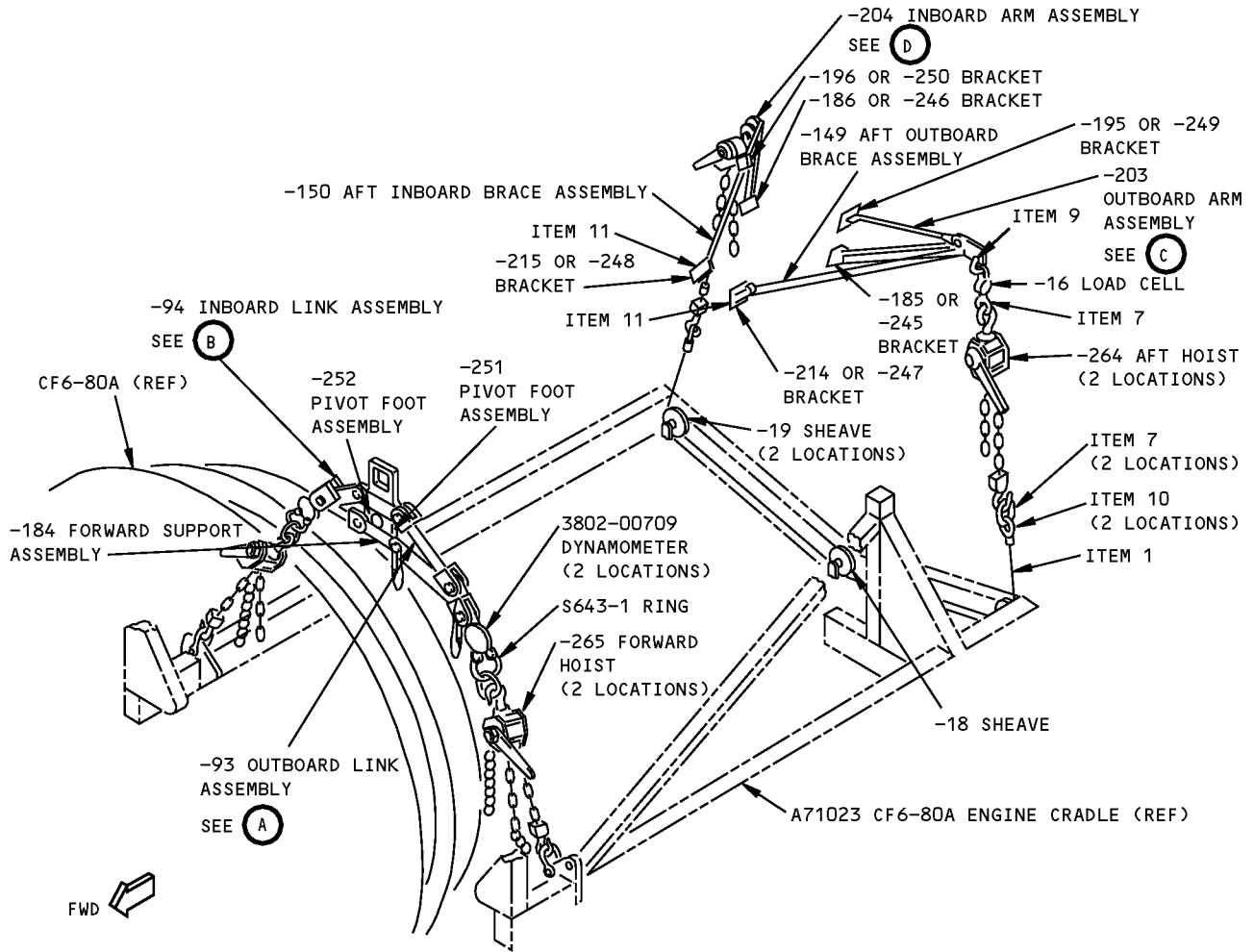

**A71011-262 BOOTSTRAP EQUIPMENT**

**General Electric Engine Bootstrap Equipment  
Figure 1 (Sheet 1 of 4)**

**767  
ILLUSTRATED TOOL AND EQUIPMENT MANUAL**

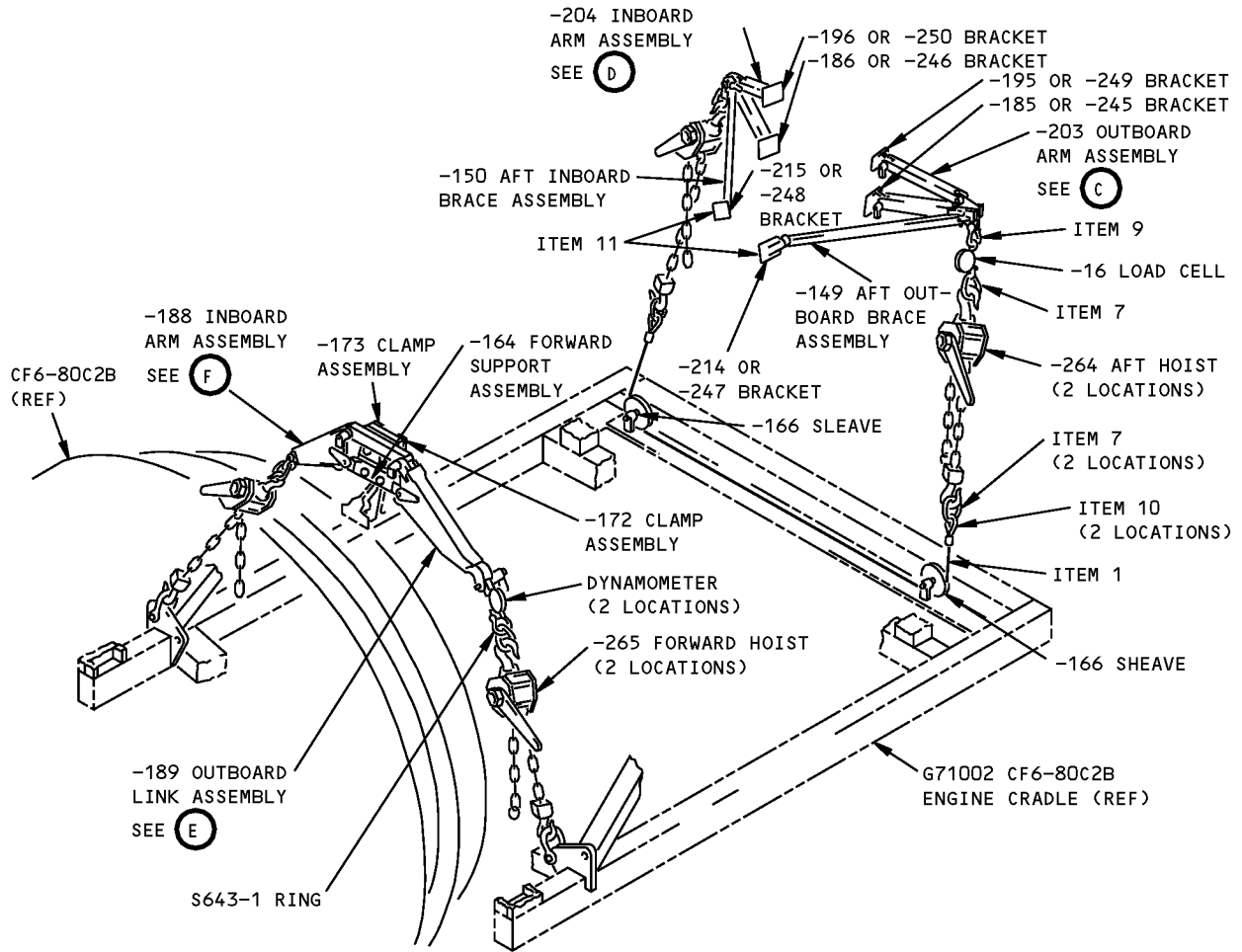

**A71011-263 BOOTSTRAP EQUIPMENT**

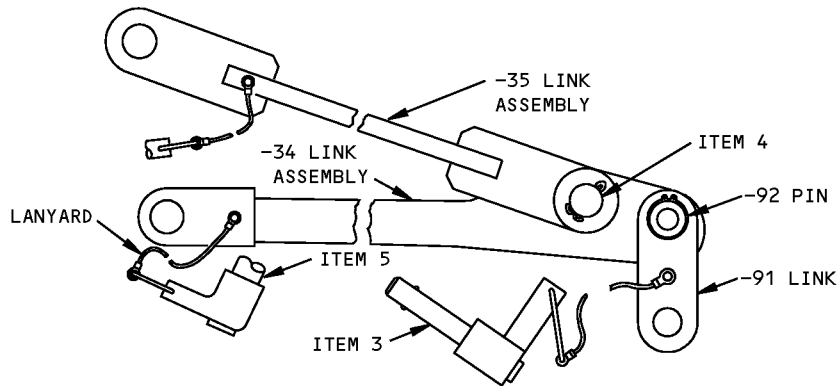

**-93 OUTBOARD LINK ASSEMBLY**

**(A)**

**General Electric Engine Bootstrap Equipment  
Figure 1 (Sheet 2 of 4)**

**ILLUSTRATED TOOL AND EQUIPMENT MANUAL**

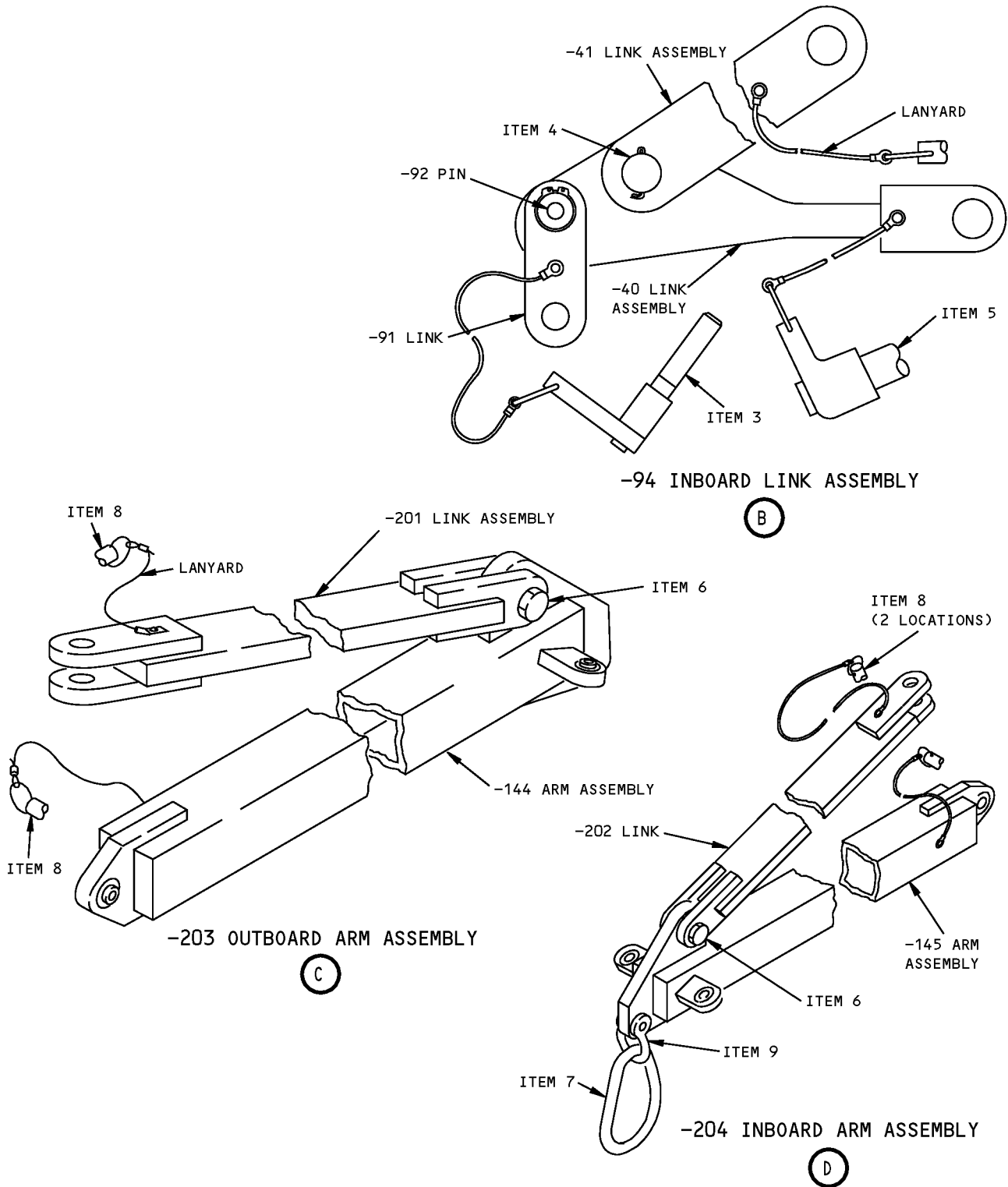

**General Electric Engine Bootstrap Equipment  
Figure 1 (Sheet 3 of 4)**

ILLUSTRATED TOOL AND EQUIPMENT MANUAL

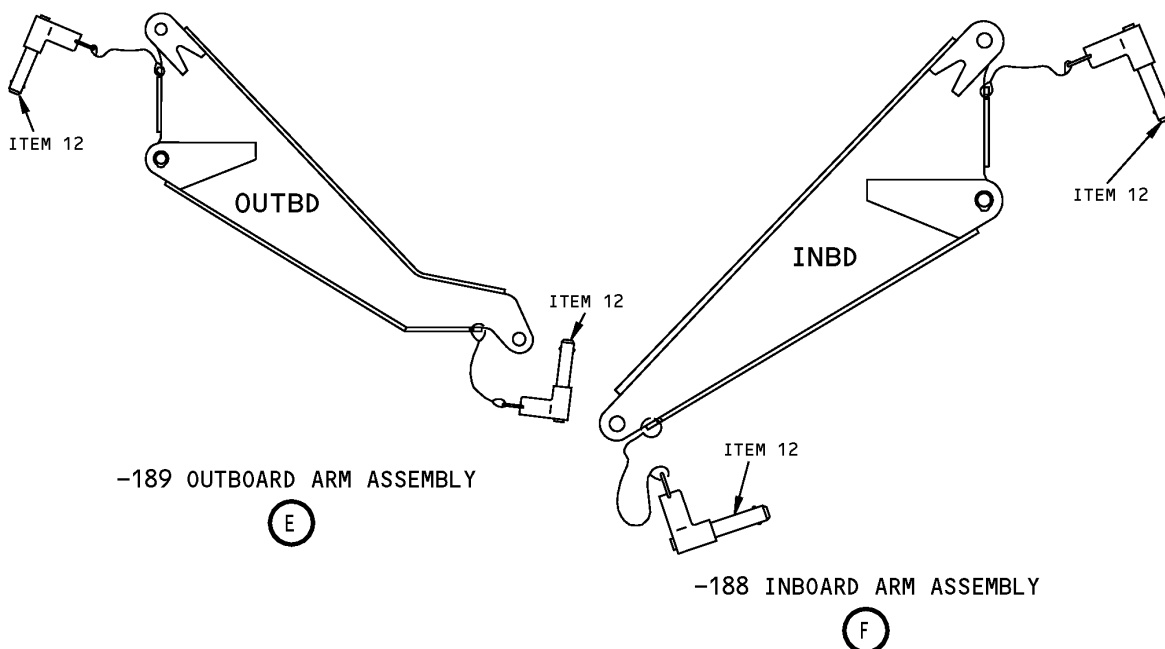

General Electric Engine Bootstrap Equipment  
Figure 1 (Sheet 4 of 4)

REPAIRABLE/REPLACEABLE PARTS			
ITEM NO.	PART NO.	NOMENCLATURE	VENDOR CODE
1	A71011-101	CABLE ASSEMBLY	
2	F70308-15	PROOF LOAD TAG	
3	NAS1341C5C17D	BALL LOCK PIN	
3	CL-12-BLPL-1.70-S (OPTIONAL)		V99862
4	MS20392-11C69	PIN	
5	NAS1342C5C21D	BALL LOCK PIN	
5	CL-14-BLPL-2.00-S (OPTIONAL)		V99862
6	NAS1108-24	BOLT	
7	G-341-5/8	PEAR RING	V75535
8	NAS1338C5C16D	BALL LOCK PIN	
8	CL-8-BLPL-1.60-S (OPTIONAL)		V99862
9	G-209-7/16	SHACKLE	V75535
10	G-210-7/16	SHACKLE	V75535
11	NAS1336C5C20D	BALL LOCK PIN	
11	CL-6-BLPL-2.00-S (OPTIONAL)		V99862
12	NAS1341C5C2.2D	BALL LOCK PIN	



767

ILLUSTRATED TOOL AND EQUIPMENT MANUAL

REPAIRABLE/REPLACEABLE PARTS			
ITEM NO.	PART NO.	NOMENCLATURE	VENDOR CODE
12	CL-12-BLPL-2.20-S (OPTIONAL)		V99862



767

## ILLUSTRATED TOOL AND EQUIPMENT MANUAL

**PART NUMBER: A71019-60**

**NAME:** ENGINE HANDLING EQUIPMENT - CF6-80A

**AIRPLANE MAINTENANCE:** NO

**COMPONENT MAINTENANCE:** YES

**USAGE & DESCRIPTION:** The A71019-60 engine handling equipment is during component maintenance on 767-200, -200ER, -300 and -300ER airplanes. A71019 is used in lifting/moving a bare or built-up engine, with or without engine flight mounts. Refer to The current A71019 drawing for complete usage instructions. The A71019-60 consists of:

A71019-60		
QUANTITY	NOMENCLATURE	PART NUMBER
1	BEAM ASSEMBLY	A71019-68
1	SPREADER BAR ASSEMBLY	A71019-3
1	PAD LINK ASSEMBLY	A71019-4
1	LINK ASSEMBLY	A71019-5
1	ENGINE LUG ASSEMBLY	A71019-6
1	LINK ASSEMBLY	A71019-8
1	FORWARD SPREADER BAR ASSEMBLY	A71019-41
8	WEIGHT (22 OR 25 LB +/-1 LB)	A71019-56
1	STORAGE BOX	

**WEIGHT:** 1400 lbs (635 kg)

**DIMENSIONS:** 12 x 12 x 60 inches (305 x 305 x 1524 mm)

**NOTE:** G71010 replaces A71019 for future procurement.



**767  
ILLUSTRATED TOOL AND EQUIPMENT MANUAL**

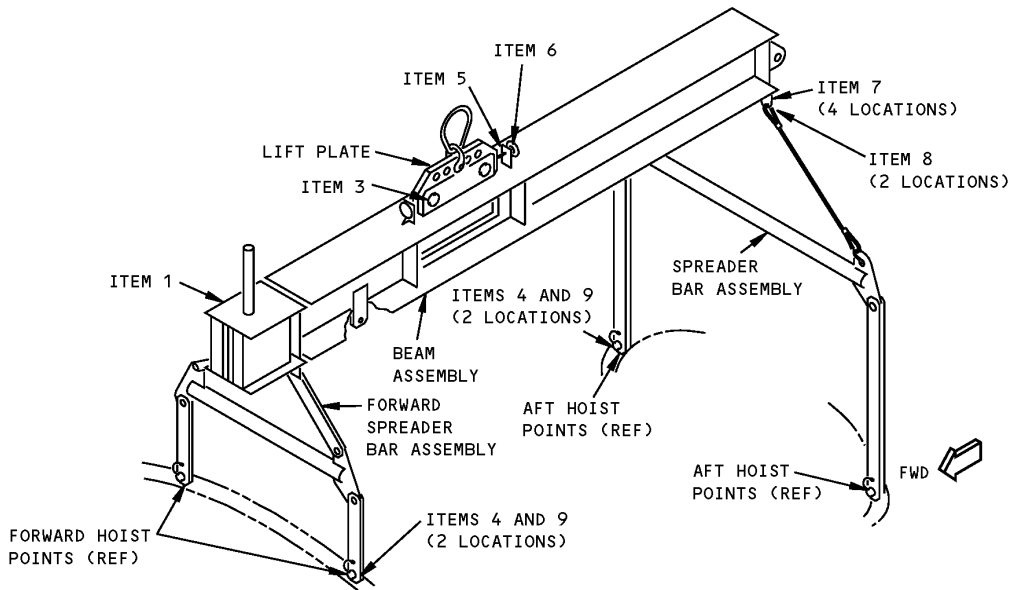

**A71019-60 CF6-80A ENGINE HANDLING EQUIPMENT  
USAGE I FORWARD AND AFT HOIST POINTS**

**CF6-80A Engine Handling Equipment  
Figure 1 (Sheet 1 of 2)**

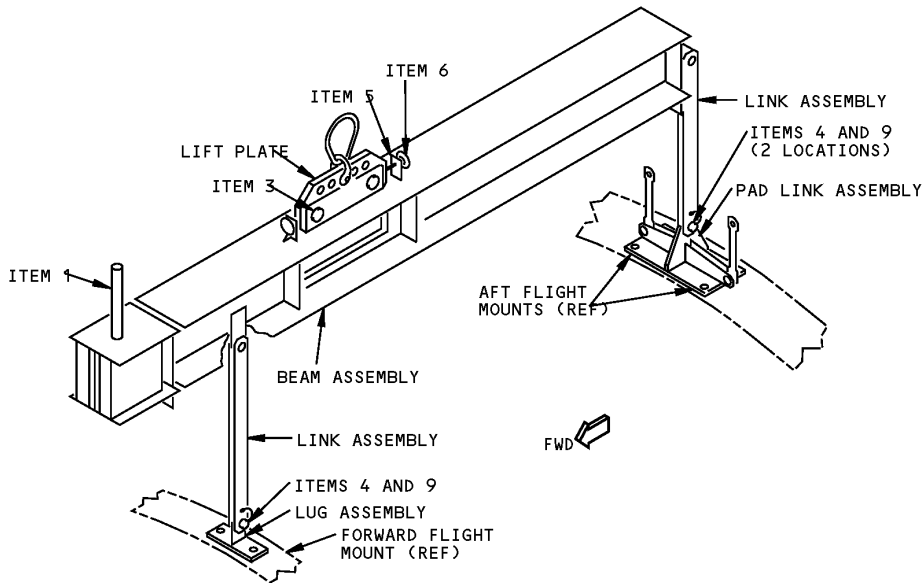

**A71019-60 CF6-80A ENGINE HANDLING EQUIPMENT  
USAGE II FORWARD AND AFT FLIGHT MOUNTS**

**CF6-80A Engine Handling Equipment  
Figure 1 (Sheet 2 of 2)**



767

ILLUSTRATED TOOL AND EQUIPMENT MANUAL

REPAIRABLE/REPLACEABLE PARTS			
ITEM NO.	PART NO.	NOMENCLATURE	VENDOR CODE
1	A71019-56	WEIGHTS	
2	A71019-19	HEX FILLER	
3	CL-23-KA-10LR	LANYARD	V99862
4	A71019-39	SET SCREW	
5	20213	HAND KNOB SCREW ASSEMBLY	
6	G-209-5/8	SHACKLE	V75535
7	G-414-1/2	THIMBLE	V75535
8	NAS1340C2C25D	BALL LOCK PIN	



767

**ILLUSTRATED TOOL AND EQUIPMENT MANUAL**

**PART NUMBER: A71020-1**

**NAME:** PROOF LOAD FIXTURE - CRADLE, CF6-80A ENGINE

**AIRPLANE MAINTENANCE:** NO

**COMPONENT MAINTENANCE:** YES

**USAGE & DESCRIPTION:** The A71020-1 proof load fixture is used to proof load the A71023 engine cradle, used on 767 airplanes equipped with CF6-80A engines. Refer to the current A71020 and A71023 drawings for complete usage instructions. A71020-1 consists of a A71020-2 forward mount, a A71020-3 aft mount and various connecting hardware.

**WEIGHT:** 1525 lbs (692 kg)

**DIMENSIONS:** 28 x 93 inches x 122 inches (711 x 2362 x 3099 mm)

ILLUSTRATED TOOL AND EQUIPMENT MANUAL

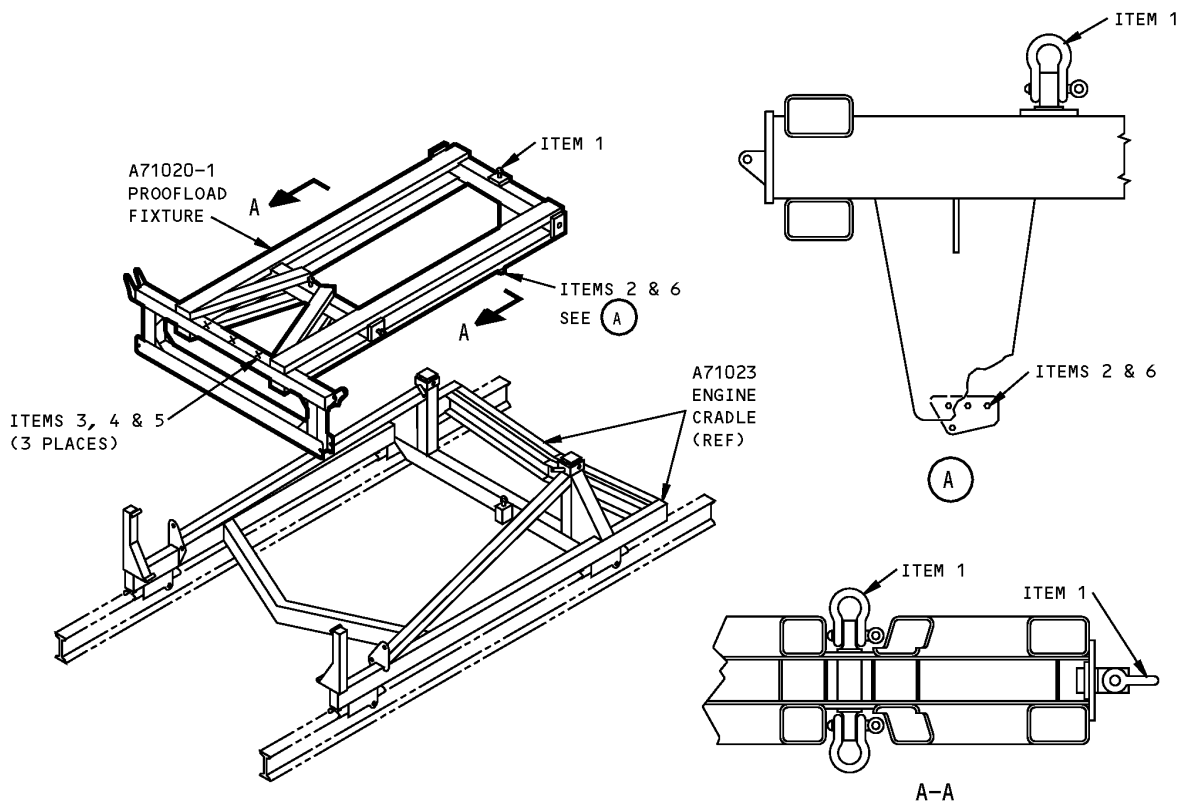

CF6-80A Engine Cradle Proof Load Fixture  
Figure 1

REPAIRABLE/REPLACEABLE PARTS			
ITEM NO.	PART NO.	NOMENCLATURE	VENDOR CODE
1	G-209-7/8	SHACKLE	V75535
2	MS35338-44	LOCK WASHER	
3	AN960XC716	WASHER	
4	AN315C7R	NUT	
5	AN7C53A	BOLT	
6	AN4C11A	BOLT	

## ILLUSTRATED TOOL AND EQUIPMENT MANUAL

**PART NUMBER: A71021-52****NAME:** PROOF LOAD FIXTURE - BOOTSTRAP, GE ENGINES**AIRPLANE MAINTENANCE:** NO**COMPONENT MAINTENANCE:** YES

**USAGE & DESCRIPTION:** A71021-52 proof load fixture is used tool to proof load the A71011-262 (767 airplanes with CF6-80A engines) or A71011-263 (767 airplanes with CF6-80C2 engines) bootstrap equipment. A71021 is also applicable to G71001 bootstrap equipment for GE engines on 747 airplanes. Refer to the current A71011 and A71021 drawings for complete usage instructions. A71021-52 consists of an A71021-53 base assembly, an A71021-37 forward mount assembly and various connecting hardware.

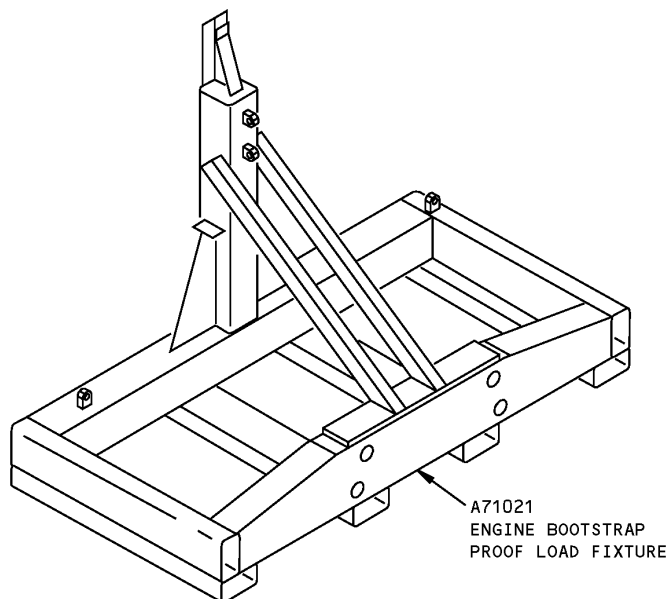
**WEIGHT:** 1750 lbs (794 kg)**DIMENSIONS:** 55 x 91 x 110 inches (1397 x 2311 x 2794 mm)**NOTE:** A71021-52 supersedes A71021-36.

**GE Engines Bootstrap Proof Load Fixture  
Figure 1**



767

## ILLUSTRATED TOOL AND EQUIPMENT MANUAL

**PART NUMBER: A71023-53, -56**

**NAME:** CRADLE - CF6-80A ENGINE 90 - INCH RAIL

**AIRPLANE MAINTENANCE:** YES

**COMPONENT MAINTENANCE:** NO

**USAGE & DESCRIPTION:** The A71023-53 (roller mounted) or -56 (bolted) cradle is used on 767 airplanes equipped with CF6-80A engines. A71023-53 is used in conjunction with the A71011 bootstrap equipment to remove or install the CF6-80A engine. The A71023-56 includes the A71023-53 usage application but also includes use with a 90-inch rail stand for transportation and storage. The A71023-56 engine cradle is directly bolted to a 90-inch rail system transportation stand. The overall height will allow for air shipment on a Lockheed L-100. A71023-53 can be modified to the A71023-56 configuration by removing the roller assemblies, drilling appropriate holes and adding appropriate connecting hardware. Refer to AMM 71-00-02 for complete usage instructions. A71023-53 and -56 consist of:

A71023-53		
QUANTITY	NOMENCLATURE	PART NUMBER
1	CRADLE ASSEMBLY	A71023-52
2	FORWARD ADAPTER ASSEMBLY	A71023-30
8	BOLT	AN10-11A
4	ROLLER ASSEMBLY	110095-11

A71023-56		
QUANTITY	NOMENCLATURE	PART NUMBER
1	CRADLE ASSEMBLY	A71023-52
2	FORWARD ADAPTER ASSEMBLY	A71023-30
2	GUIDE PIN	A71023-55
8	BEVEL WASHER	NAS1099-6610
4	BOLT	NAS6610-17

**WEIGHT:** 2100 lbs (953 kg)

**DIMENSIONS:** 56 x 96 x 141 inches (1422 x 2438 x 3581 mm)

**NOTE:** A71023-53 supersedes A71023-1.

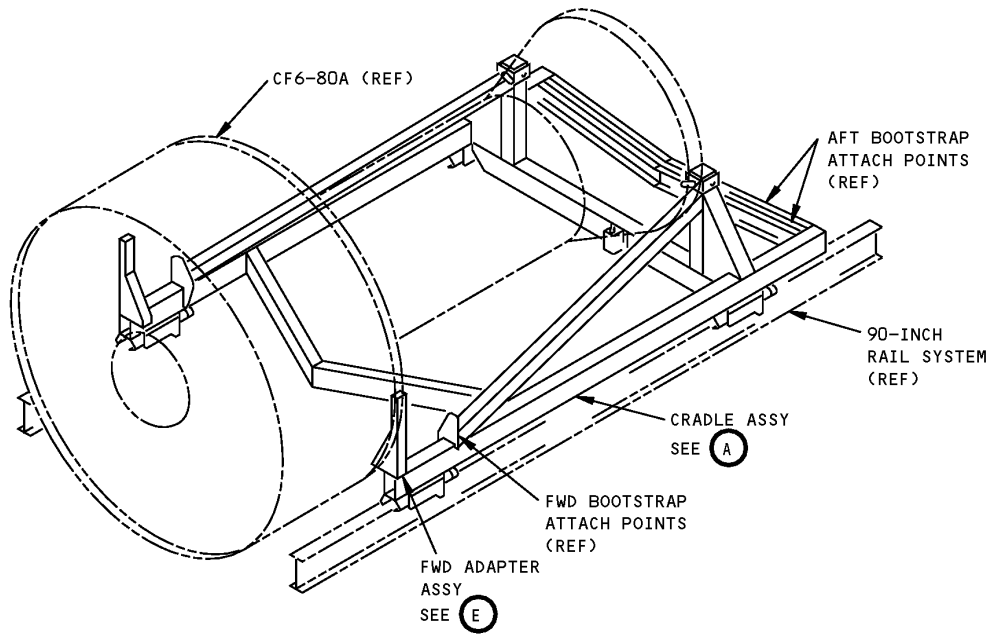

**CF6-80A Engine 90 - Inch Rail Cradle  
Figure 1 (Sheet 1 of 4)**

**767**  
**ILLUSTRATED TOOL AND EQUIPMENT MANUAL**

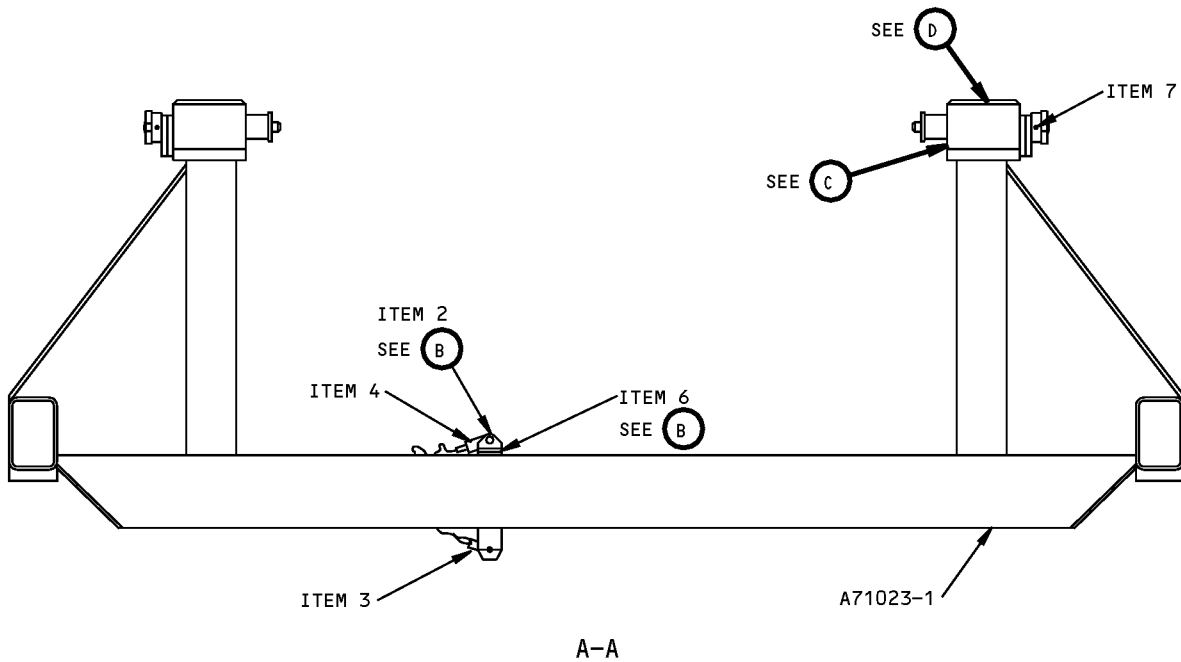
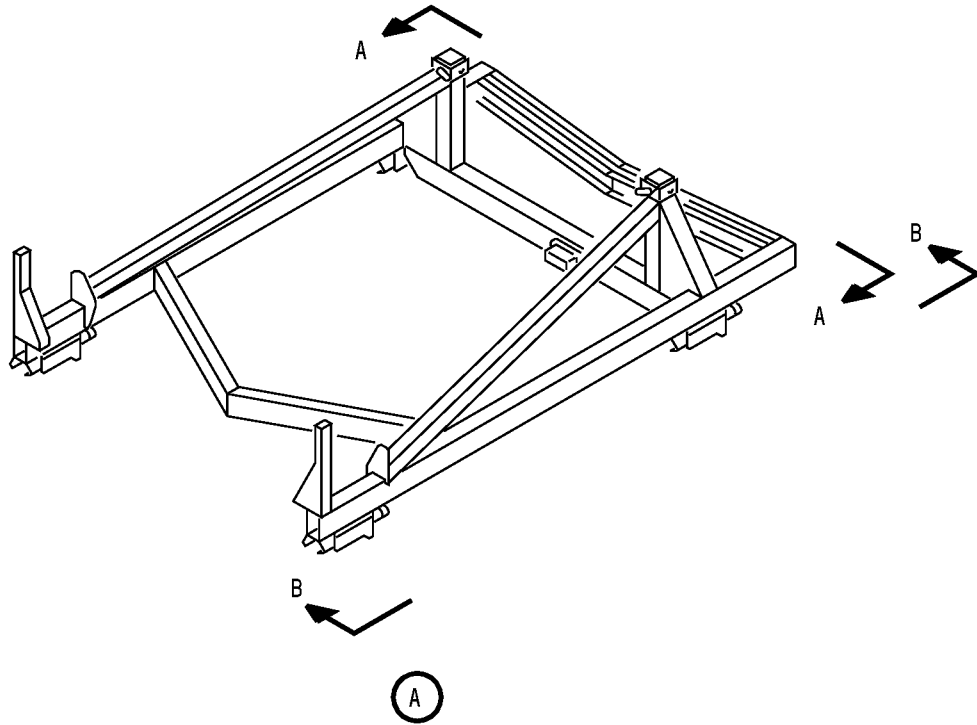

**CF6-80A Engine 90 - Inch Rail Cradle**  
**Figure 1 (Sheet 2 of 4)**



**767**  
**ILLUSTRATED TOOL AND EQUIPMENT MANUAL**

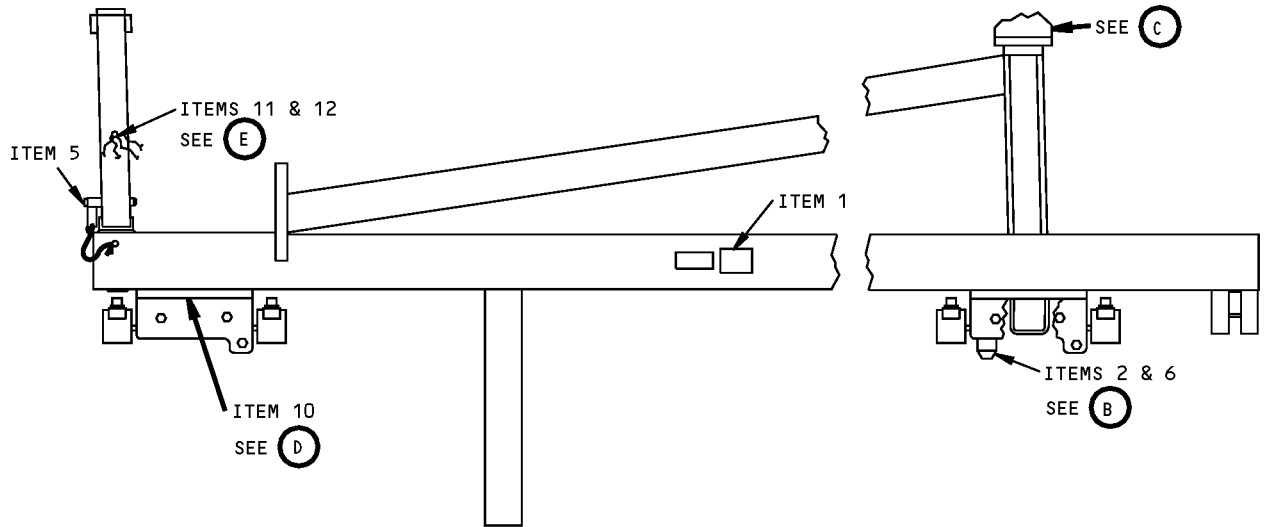

A71023  
B-B

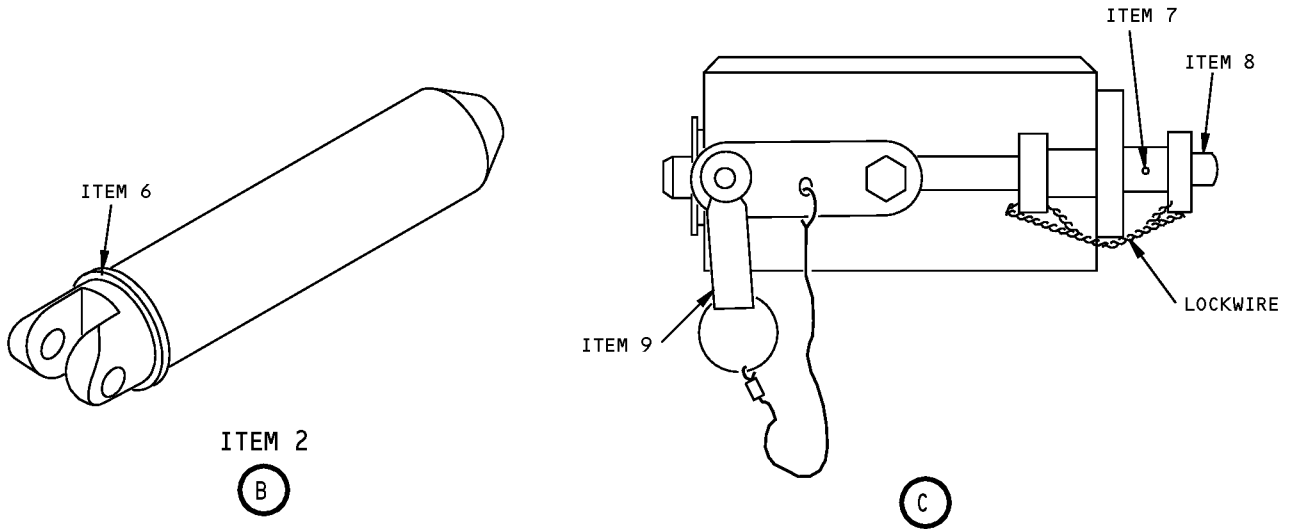

**CF6-80A Engine 90 - Inch Rail Cradle**  
**Figure 1 (Sheet 3 of 4)**

ILLUSTRATED TOOL AND EQUIPMENT MANUAL

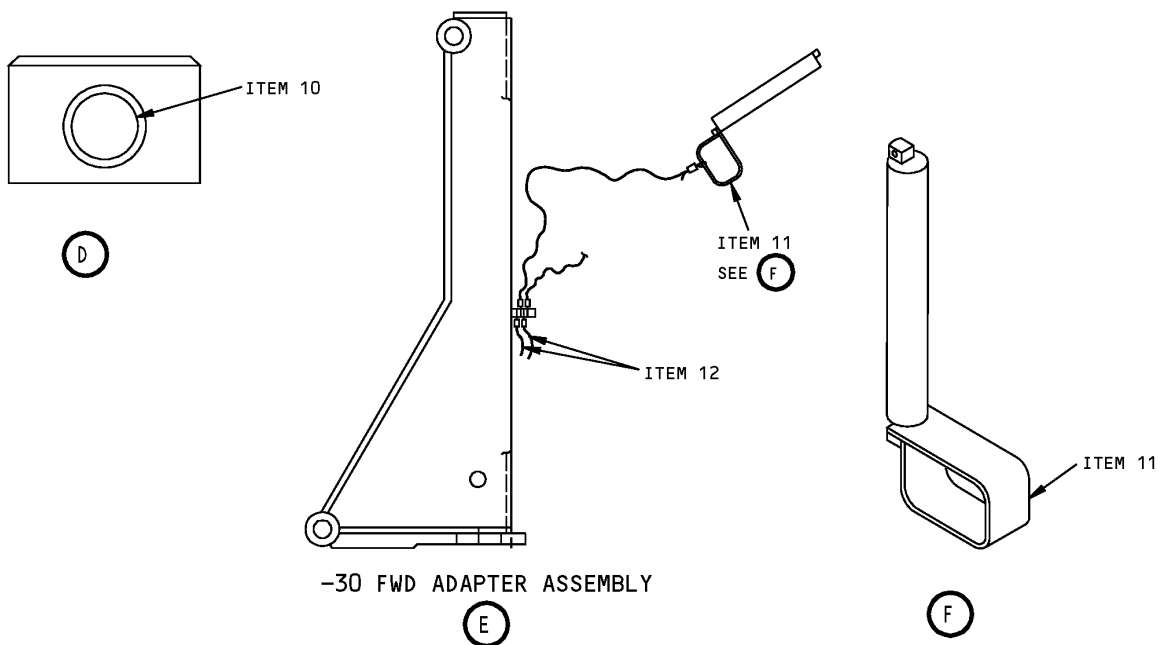

CF6-80A Engine 90 - Inch Rail Cradle  
Figure 1 (Sheet 4 of 4)

REPAIRABLE/REPLACEABLE PARTS			
ITEM NO.	PART NO.	NOMENCLATURE	VENDOR CODE
1	A71023-19	PIN	
2	NAS1334C5C20D	QUICK RELEASE PIN	
3	NAS1339C5C20D	QUICK RELEASE PIN	
4	NAS1341C5C31D	QUICK RELEASE PIN	
5	5100-200	RETAINING RING	V99652
6	MS16562-227	SPRING PIN	
7	MS16562-194	SPRING PIN	
8	NAS1340C5C1.50	QUICK RELEASE PIN	
9	B3240-16	BUSHING	V71041
10	A71023-37	PIN ASSEMBLY	
11	25-06	SAFETY PIN	V79136



767

**ILLUSTRATED TOOL AND EQUIPMENT MANUAL**

**PART NUMBER: A71006-79**

**NAME:** CRADLE - PRATT AND WHITNEY ENGINES, 90-INCH RAIL

**AIRPLANE MAINTENANCE:** YES

**COMPONENT MAINTENANCE:** NO

**USAGE & DESCRIPTION:** The A71006 cradle is used on 767 airplanes equipped with Pratt and Whitney engines. A71006 is used with both the 90-inch rail-mounted transportation/storage dolly and the A71001 bootstrap equipment. Refer to AMM 71-00-02 for complete usage instructions. A71006-79 consists of:

<b>A71006-79</b>		
<b>QUANTITY</b>	<b>NOMENCLATURE</b>	<b>PART NUMBER</b>
2	FORWARD ADAPTER ASSEMBLY	A71006-80
2	AFT ADAPTER ASSEMBLY	A71006-60
1	CRADLE ASSEMBLY	A71006-61

**WEIGHT:** 2400 lbs (1089 kg)

**DIMENSIONS:** 39 x 96 x 129 inches (991 x 2438 x 3277 mm)

**NOTE:** A71006-79 supersedes A71006-76.

**767**  
**ILLUSTRATED TOOL AND EQUIPMENT MANUAL**

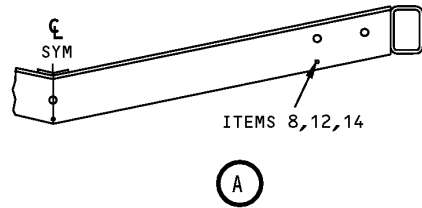
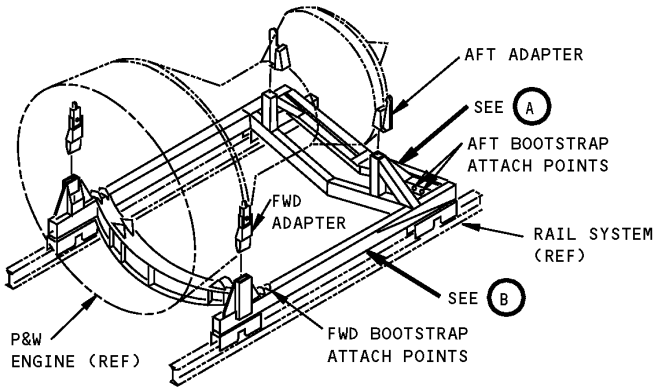

**Pratt and Whitney Engines 90 - Inch Rail Cradle**  
**Figure 1 (Sheet 1 of 3)**

**ILLUSTRATED TOOL AND EQUIPMENT MANUAL**

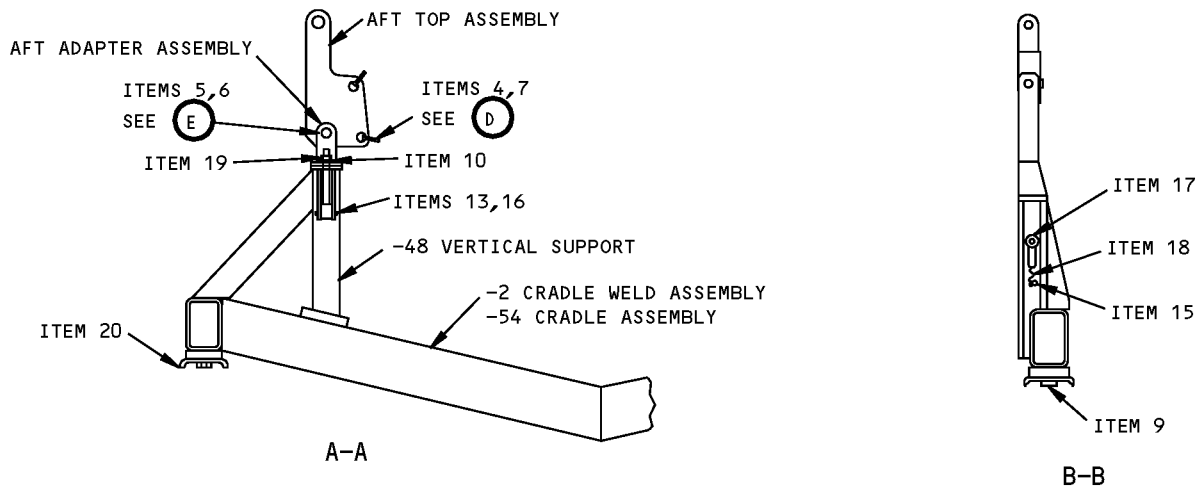
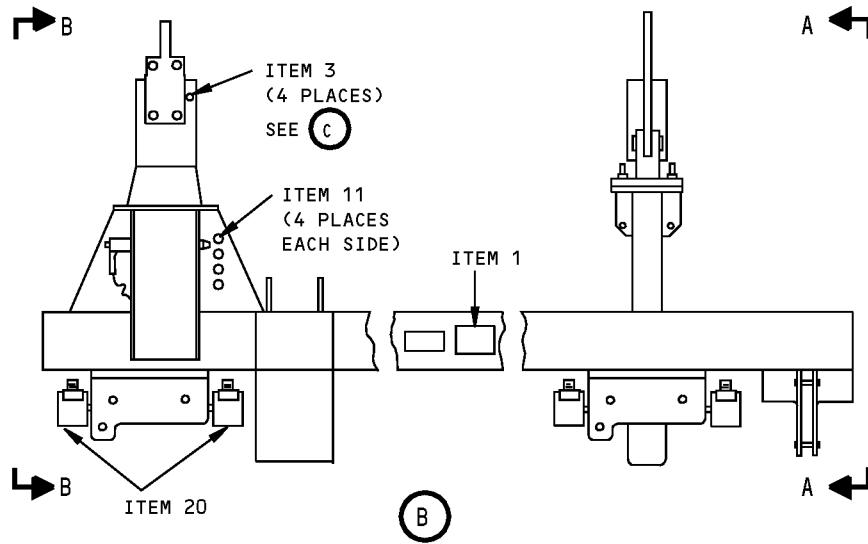

**Pratt and Whitney Engines 90 - Inch Rail Cradle  
Figure 1 (Sheet 2 of 3)**

ILLUSTRATED TOOL AND EQUIPMENT MANUAL

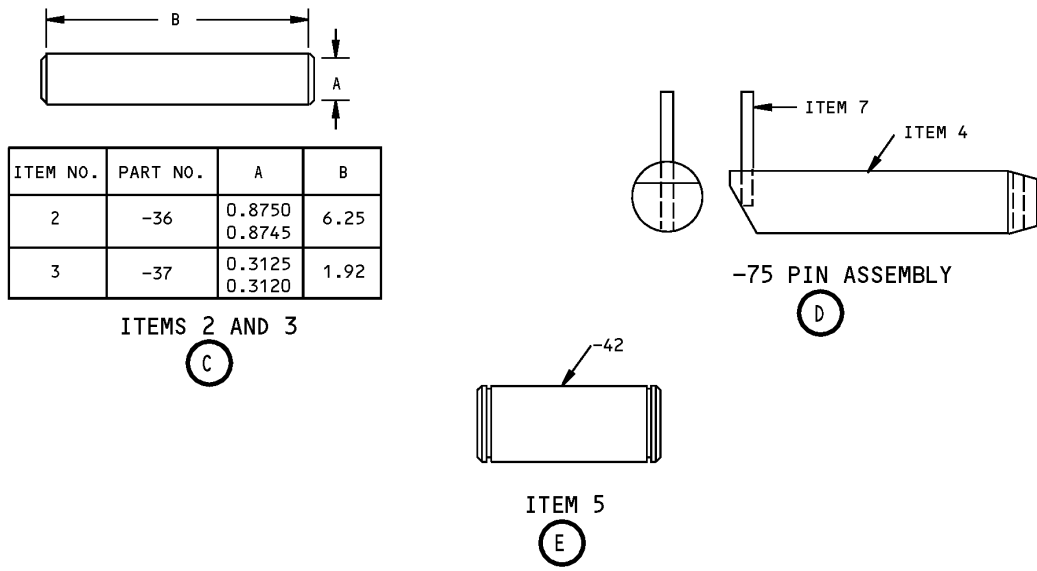

Pratt and Whitney Engines 90 - Inch Rail Cradle  
Figure 1 (Sheet 3 of 3)

REPAIRABLE/REPLACEABLE PARTS			
ITEM NO.	PART NO.	NOMENCLATURE	VENDOR CODE
1	F70308-15	PROOF LOAD TAG	
2	A71006-36	PIN	
3	A71006-37	PIN	
4	A71006-75	PIN ASSEMBLY	
5	A71006-42	PIN	
6	5100-125	RETAINING PIN	V79136
7	63-02	LYNCH PIN	V65029
8	AN4-23A	BOLT	
9	AN10-11A	BOLT	
10	AN960-1216L	WASHER	
11	MS20008-8	BOLT	
12	MS21044N4	NUT	
13	MS21044N12	SELF LOCKING NUT	
14	NAS43HT4-80	SPACER	
15	NAS602-4	SCREW	
16	NAS1312-32	BOLT	



767

ILLUSTRATED TOOL AND EQUIPMENT MANUAL

REPAIRABLE/REPLACEABLE PARTS			
ITEM NO.	PART NO.	NOMENCLATURE	VENDOR CODE
17	NAS1342C5C71D	QUICK RELEASE PIN	
18	CL-73-KA-12	CABLE ASSEMBLY	V99862
19	29510	LATCH SCREW	V94882
20	110095-11	ROLLER ASSEMBLY	V13189



767

## ILLUSTRATED TOOL AND EQUIPMENT MANUAL

**PART NUMBER: A71025-1**

**NAME:** SUPPORT PEDESTAL EQUIPMENT - CF6-80A ENGINE BUILDUP

**AIRPLANE MAINTENANCE:** NO

**COMPONENT MAINTENANCE:** YES

**USAGE & DESCRIPTION:** The A71025-1 support pedestal equipment is used on 767 airplanes equipped with CF6-80A engines. A71025 consists of four assemblies that are used to support the CF6-80A engine during 'quick engine change' buildup and tear down. The A71025 pedestal equipment is not designed to support excessive forward, aft or side loads. Refer to the CF6-80A Power Plant Buildup Manual 71-00-00 for additional information. A71025-1 consists of:

A71025-1		
QUANTITY	NOMENCLATURE	PART NUMBER
2	FORWARD PEDESTAL ASSEMBLY	A71025-2
1	BAR	A71025-3
1	LEFT PEDESTAL ASSEMBLY	A71025-4
1	RIGHT PEDESTAL ASSEMBLY	A71025-5

**WEIGHT:** 2000 lbs (907 kg)

**DIMENSIONS:** 36 x 93 x 144 inches (914 x 2362 x 3658 mm)



**ILLUSTRATED TOOL AND EQUIPMENT MANUAL**

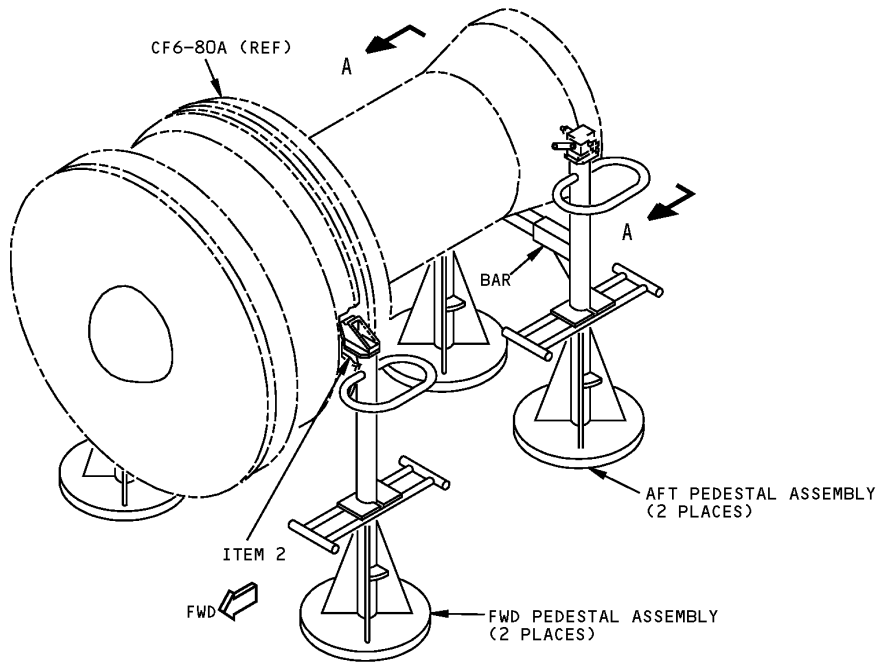

**CF6-80A Engine Buildup Support Pedestal Equipment  
Figure 1 (Sheet 1 of 2)**

ILLUSTRATED TOOL AND EQUIPMENT MANUAL

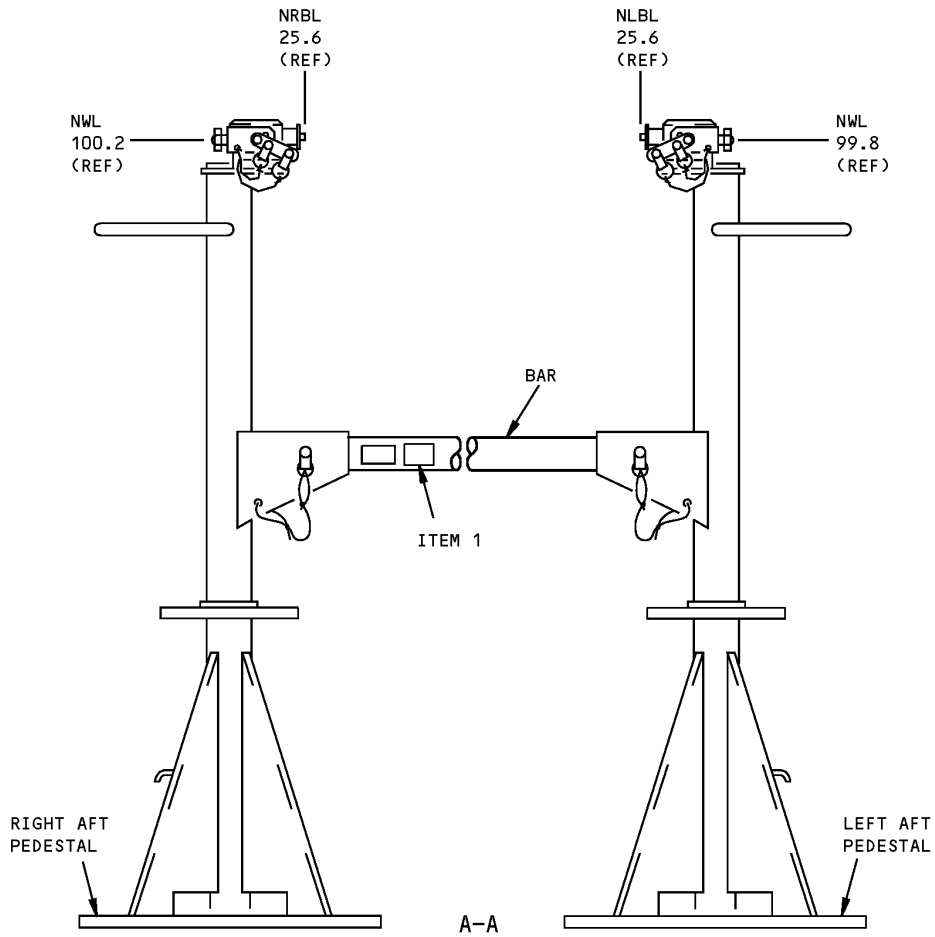

CF6-80A Engine Buildup Support Pedestal Equipment  
Figure 1 (Sheet 2 of 2)

REPAIRABLE/REPLACEABLE PARTS			
ITEM NO.	PART NO.	NOMENCLATURE	VENDOR CODE
1	F70308-15	PROOF LOAD TAG	
2	A71025-7	PIN ASSEMBLY	



767

## ILLUSTRATED TOOL AND EQUIPMENT MANUAL

**PART NUMBER: A71024-1, -51, -68, -70**

**NAME:** LOCATING JIG - CF6-80A BUILDUP-TO-STRUT SYSTEM INTERFACES

**AIRPLANE MAINTENANCE:** NO

**COMPONENT MAINTENANCE:** YES

**USAGE & DESCRIPTION:** The A71024-1 or -68 locating jig is used on 767 airplanes equipped with CF6-80A engines. The A71024-51 or -70 locating jig is used only on ANA 767 airplanes equipped with CF6-80A engines. A71024 is used to locate and interface the various engine buildup systems and provide connection paths for systems hookup. A mylar pattern is required for fabrication. The mylar pattern may be obtained by a request to Maintenance and Ground Operations Systems (MGOS) at Boeing Commercial Airplanes Services. Refer to the current A71024 drawing and the 767 CF6-80A Powerplant Buildup Manual for complete usage instructions. A71024 consists of the following major components: the locating jig, the front and aft pedestals, the raceway assemblies and two mount boxes.

**WEIGHT:** 150 lbs (68 kg)

**DIMENSIONS:** 36 X 40 110 inches (914 x 1016 x 2794 mm)

**NOTE:** A71024-68 and -70 replaces A71024-1 and -51, respectively.

**ILLUSTRATED TOOL AND EQUIPMENT MANUAL**

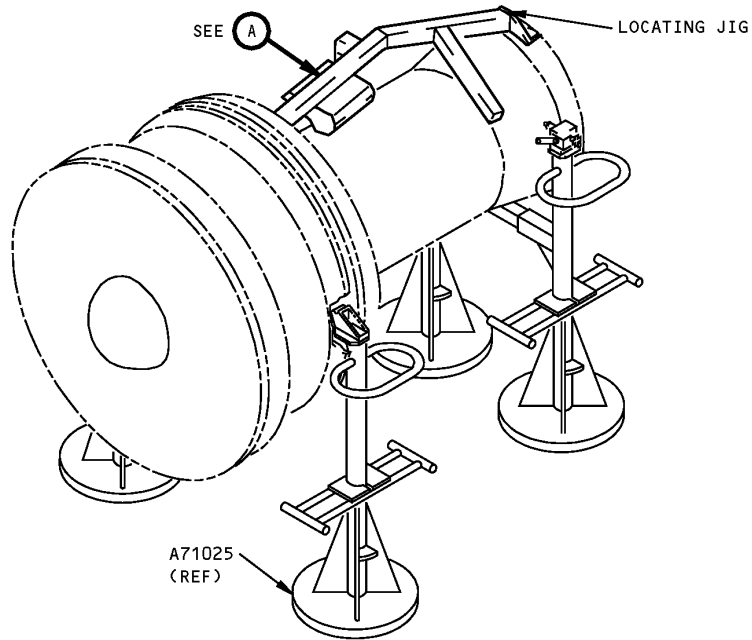

**CF6-80A Engine Buildup-to-Strut Systems Interfaces Locating Jig  
Figure 1 (Sheet 1 of 2)**

**767**  
**ILLUSTRATED TOOL AND EQUIPMENT MANUAL**

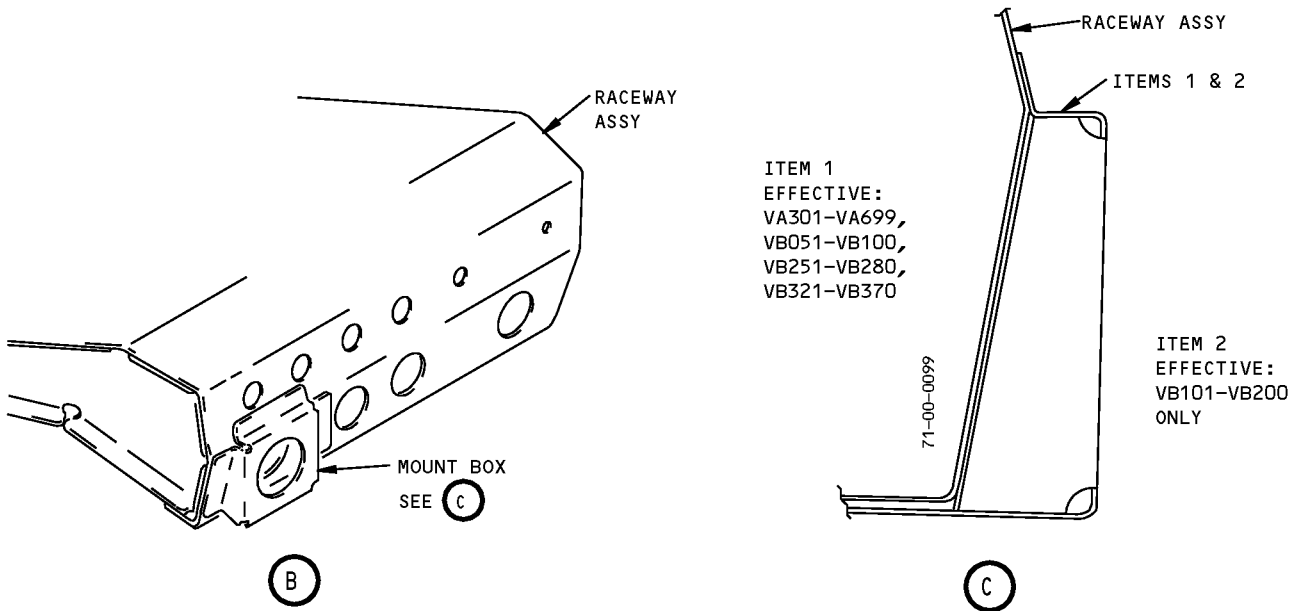
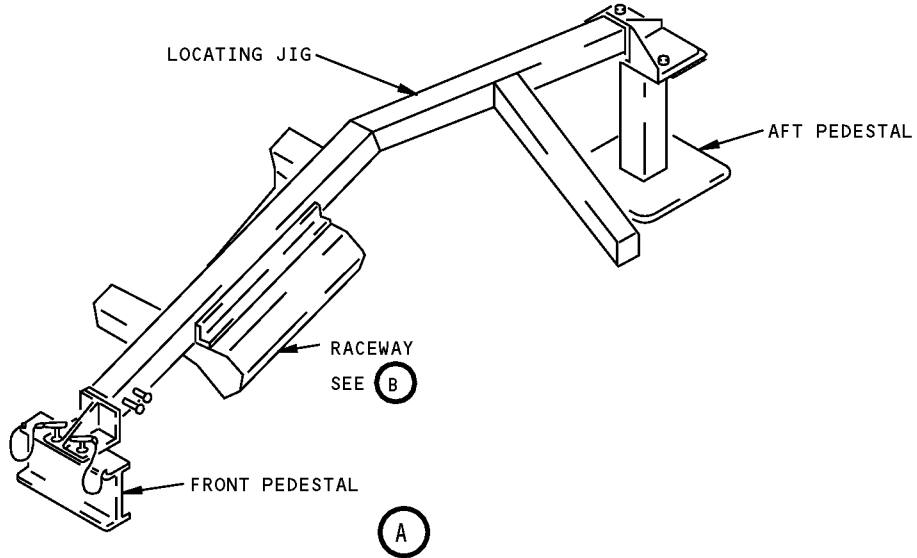

**CF6-80A Engine Buildup-to-Strut Systems Interfaces Locating Jig**  
**Figure 1 (Sheet 2 of 2)**



767

ILLUSTRATED TOOL AND EQUIPMENT MANUAL

REPAIRABLE/REPLACEABLE PARTS			
ITEM NO.	PART NO.	NOMENCLATURE	VENDOR CODE
1	A71024-35	MOUNT BOX	
2	A71024-53	MOUNT BOX	

**ILLUSTRATED TOOL AND EQUIPMENT MANUAL**

**PART NUMBER: A71022-1, -60**

**NAME:** LOCATING JIG - ENGINE BUILDUP TO STRUT SYSTEMS INTERFACES JT9D-7R4D ENGINE

**AIRPLANE MAINTENANCE:** NO

**COMPONENT MAINTENANCE:** YES

**USAGE & DESCRIPTION:** The A71022-1 locating jig is used on 767 airplanes equipped with JT9D-7R4D engines except for effectivities VB301-VB320. The A71022-60 locating jig is used on 767 airplanes equipped with JT9D-7R4D engines only on effectivities VB301-VB320. A71022 is used during engine buildup to align pneumatic tubes and electrical connectors to provide correct mating to the airplane engine struts. A mylar pattern is required for fabrication. The mylar pattern may be obtained by a request to Maintenance and Ground Operations Systems (MGOS) at Boeing Commercial Airplanes Services. Refer to AMM 71-00 and the current A71022 drawing for complete usage instructions. A71022 generally consists of a locating jig, forward and aft mounts, forward and aft pedestal assemblies and the raceway assembly.

**WEIGHT:** 150 lbs (68 kg)

**DIMENSIONS:** 40 x 50 x 95 inches (1016 x 1270 x 2413 mm)

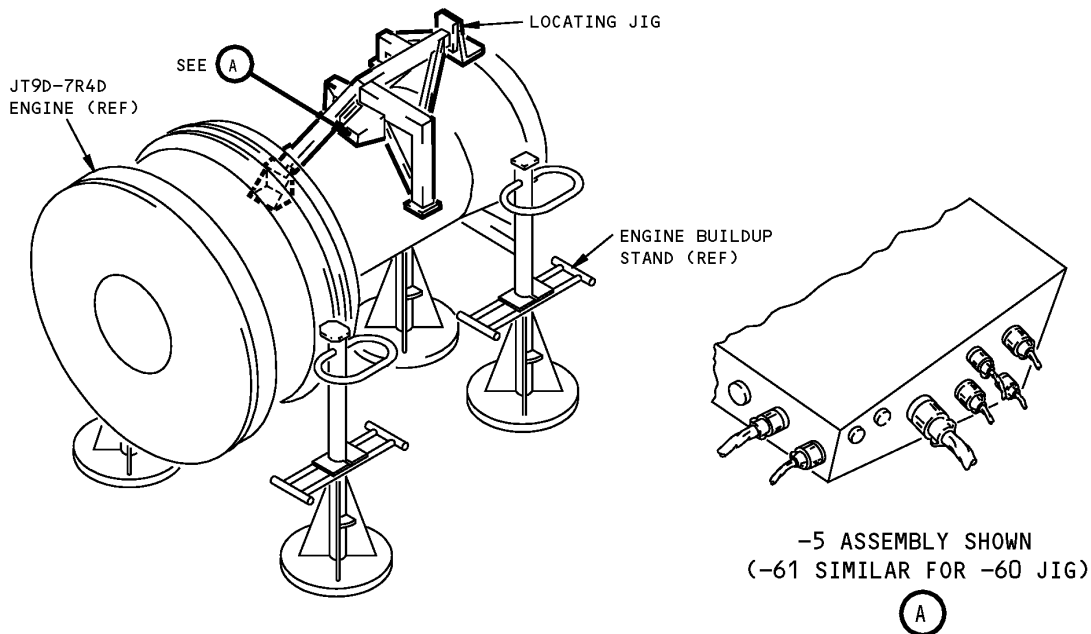

**Systems Interfaces, JT9D-7R4D Engine Buildup to Strut Locating Jig  
Figure 1**



767

## ILLUSTRATED TOOL AND EQUIPMENT MANUAL

**PART NUMBER: A71030-32**

**NAME:** HOLD OPEN EQUIPMENT - FAN COWL, 40 KNOTS, PRATT AND WHITNEY ENGINES

**AIRPLANE MAINTENANCE:** YES

**COMPONENT MAINTENANCE:** NO

**USAGE & DESCRIPTION:** The A71030-32 hold open equipment is used on 767 airplanes equipped with JT9D-7R4D or PW4000 engines. A71030 is used for holding the fan cowl in open position. Refer to AMM 71-00-02 for complete usage instructions. A71030-32 consists of an A71030-33 left hand hold-open assembly and an A71030-34 right hand hold-open assembly, both contained in a storage box.

**WEIGHT:** 98 lbs (44 kg)

**DIMENSIONS:** 10 x 50 x 112 inches (254 x 1270 x 2845 mm)

**NOTE:** A71030 and A71032 supersede A71010.  
A71030-32 supersedes A71030-1.

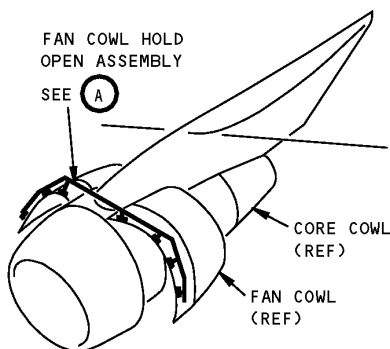

**Pratt and Whitney Engine Fan Cowl 40 Knot Hold Open Equipment  
Figure 1 (Sheet 1 of 2)**



**767**  
**ILLUSTRATED TOOL AND EQUIPMENT MANUAL**

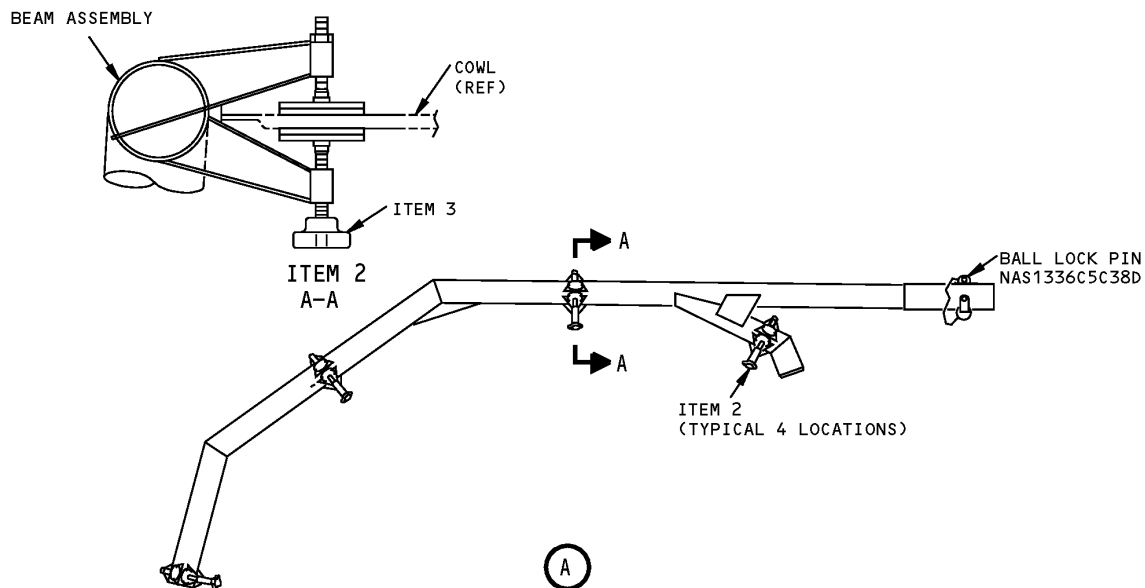

**Pratt and Whitney Engine Fan Cowl 40 Knot Hold Open Equipment**  
**Figure 1 (Sheet 2 of 2)**

REPAIRABLE/REPLACEABLE PARTS			
ITEM NO.	PART NO.	NOMENCLATURE	VENDOR CODE
1	F70308-15	PROOF LOAD TAG	
2	A71030-8	CLAMP PAD ASSEMBLY	
3	TH-104	ADJUSTABLE TORQUE HANDLE	V01226

**ILLUSTRATED TOOL AND EQUIPMENT MANUAL**

**PART NUMBER: A71032-14**

**NAME:** HOLD-OPEN EQUIPMENT - 40 KNOTS, PRATT AND WHITNEY CORE COWLS

**AIRPLANE MAINTENANCE:** YES

**COMPONENT MAINTENANCE:** NO

**USAGE & DESCRIPTION:** The A71032-14 hold-open equipment is used on the 767 airplanes equipped with JT9D-7R4D or PW4000 core cowls. A71032 is used for holding the core cowl in an open position. The A71032 hold-open assemblies are used with two A71001 -116 aft bracket hold-open assemblies. Refer to AMM 71-00-02 for complete usage information. A71032-14 consists of an A71032-19 forward left hand hold-open assembly, an A71032-20 forward right hand hold-open assembly, an A71032-21 aft left hand hold-open assembly, an A71032-22 aft right hand hold-open assemblies, all contained in a storage box.

**WEIGHT:** 30 lbs (14 kg)

**DIMENSIONS:** 3 x 4 x 37 inches (76 x 102 x 940 mm)

**NOTE:** A71032 and A71030 supersedes A71010.  
A71032-14 supersedes A71032-1.

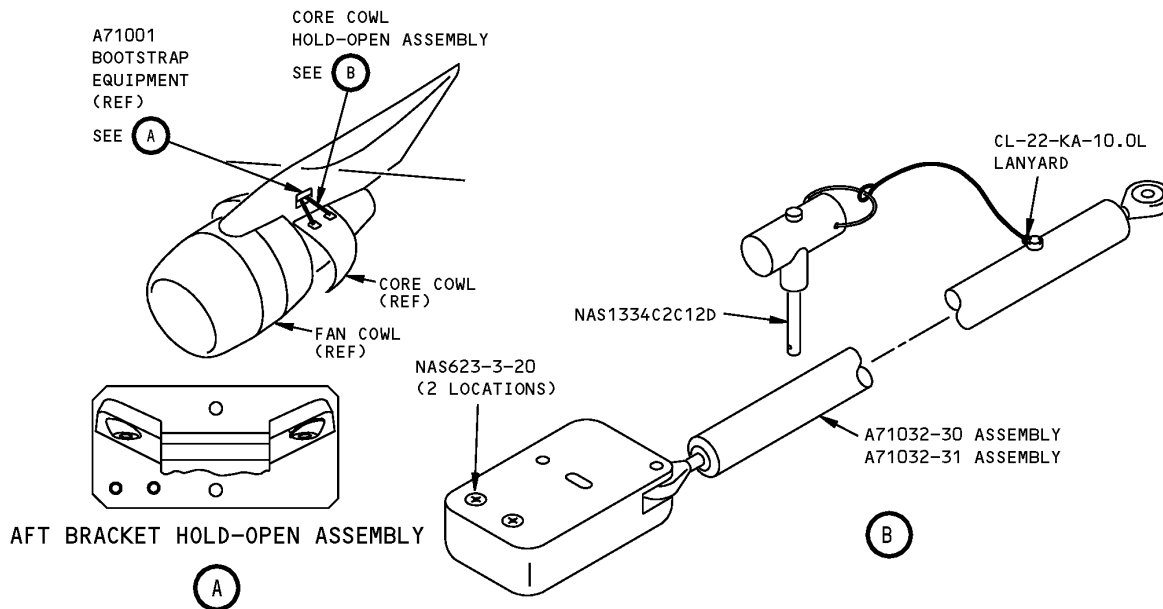

**Pratt and Whitney Core Cows, 40 Knot Hold Open Equipment  
Figure 1**

**ILLUSTRATED TOOL AND EQUIPMENT MANUAL**

**PART NUMBER: A71034-1, -2, -3**

**NAME:** WRENCH - AFT FLIGHT MOUNT ENGINE BUILDUP (EBU) "B" PACKAGE

**AIRPLANE MAINTENANCE:** YES

**COMPONENT MAINTENANCE:** YES

**USAGE & DESCRIPTION:** The A71034-1 wrench is used on airplanes equipped with the JT9D-7R4D engine. The A71034-2 wrench is used on airplanes equipped with the PW4000 engine. The A71034-3 wrench is used on 767 airplanes equipped with PW4000 and JT9D-7R4D engines. A71034 is used with a customer-furnished torque wrench to tighten the mounting bolts that secure the aft lower engine mount to the engine. Refer to AMM 71-21-02 for complete usage instructions. The A71034-1, -2 or -3 wrenches are all manufactured from a commercially-procured Snap-On XH148B wrench.

**WEIGHT:** 1.6 lbs (0.7 kg)

**DIMENSIONS:** 1 x 3 x 13 inches (25 x 76 x 330 mm)

**NOTE:** A71034-3 replaces A71034-2 for future procurement.

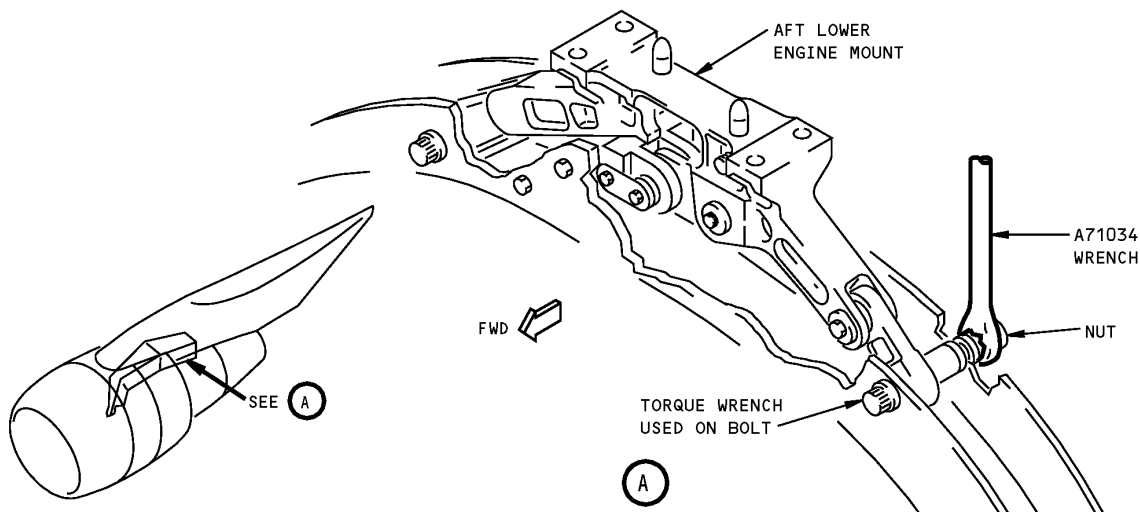

**Engine Buildup "B" Package Aft Flight Mount Wrench  
Figure 1**



767

## ILLUSTRATED TOOL AND EQUIPMENT MANUAL

**PART NUMBER: B71034-13, -29, -48**

**NAME:** TEST EQUIPMENT - ENGINE PRESSURE MONITORING

**AIRPLANE MAINTENANCE:** YES

**COMPONENT MAINTENANCE:** NO

**USAGE & DESCRIPTION:** The B71034-13 test equipment is used on 767-200 airplanes equipped with JT9D-7R4D or E engines. The B71034-29 test equipment is used on all 767 airplanes equipped with PW4000 engines. The B71034-48 test equipment is used on 767-200 or 767-300 airplanes equipped with JT9D-7R4D or E engines. B71034-48 and -13 are the same except B71034-48 has longer hoses to accommodate the 767-300. The B71034 test equipment is used to monitor engine pressure during maintenance test. Refer AMM 71-00-00 for complete usage instructions. The B71034 test equipment consists of:

<b>B71034-13</b>		
<b>QUANTITY</b>	<b>NOMENCLATURE</b>	<b>PART NUMBER</b>
1	GAUGE ASSEMBLY	A71034-15
1	GAUGE ASSEMBLY	A71034-16
1	GAUGE ASSEMBLY	A71034-17
1	GAUGE ASSEMBLY	A71034-18
1	GAUGE ASSEMBLY	A71034-19
1	HOSE ASSEMBLY	A71034-20
1	HOSE ASSEMBLY	A71034-21
1	HOSE ASSEMBLY	A71034-22
1	HOSE ASSEMBLY	A71034-23
1	HOSE ASSEMBLY	A71034-24
1	STORAGE BOX	

<b>B71034-29</b>		
<b>QUANTITY</b>	<b>NOMENCLATURE</b>	<b>PART NUMBER</b>
1	GAUGE ASSEMBLY	A71034-32
1	GAUGE ASSEMBLY	A71034-33
1	GAUGE ASSEMBLY	A71034-34
1	HOSE ASSEMBLY	A71034-37
1	HOSE ASSEMBLY	A71034-38
1	HOSE ASSEMBLY	A71034-39
1	STORAGE BOX	



**767**  
**ILLUSTRATED TOOL AND EQUIPMENT MANUAL**

<b>B71034-48</b>		
<b>QUANTITY</b>	<b>NOMENCLATURE</b>	<b>PART NUMBER</b>
1	GAUGE ASSEMBLY	A71034-15
1	GAUGE ASSEMBLY	A71034-16
1	GAUGE ASSEMBLY	A71034-17
1	GAUGE ASSEMBLY	A71034-18
1	GAUGE ASSEMBLY	A71034-19
1	HOSE ASSEMBLY	A71034-50
1	HOSE ASSEMBLY	A71034-51
1	HOSE ASSEMBLY	A71034-52
1	HOSE ASSEMBLY	A71034-53
1	HOSE ASSEMBLY	A71034-54
1	STORAGE BOX	

**WEIGHT:** B71034-13 - 100 lbs (45 kg)  
B71034-29 - 50 lbs (23 kg)  
B71034-48 - 100 lbs (45 kg)

**DIMENSIONS:** B71034-13 - 12 x 30 x 70 inches (305 x 762 x 1778 mm)  
B71034-29 - 12 x 24 x 48 inches (305 x 610 x 1219 mm)  
B71034-48 - 12 x 30 x 70 inches (305 x 762 x 1778 mm)

**NOTE:** B71034-48 replaces B71034-13 for future procurement.

**767  
ILLUSTRATED TOOL AND EQUIPMENT MANUAL**

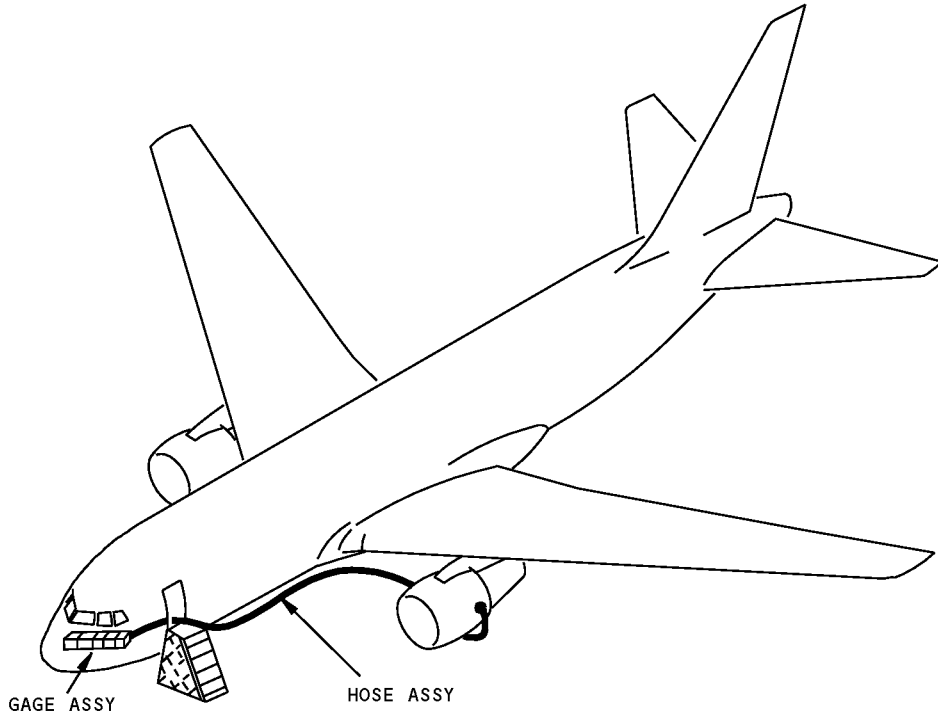

**Engine Pressure Monitoring Test Equipment  
Figure 1**

**ILLUSTRATED TOOL AND EQUIPMENT MANUAL**

**PART NUMBER: A71029-36**

**NAME:** HOLD OPEN EQUIPMENT - FAN COWL, 20 KNOT, JT9D-7R4 ENGINE

**AIRPLANE MAINTENANCE:** YES

**COMPONENT MAINTENANCE:** NO

**USAGE & DESCRIPTION:** The A71029-36 hold open equipment is used on 767 airplanes equipped with JT9D7R4 engines. A71029 is used with the A78001 thrust reverser hold open equipment to hold open the fan cowls during a JT9D-7R4 engine change or during engine maintenance. A71029 is limited to winds of 20 knots or less. Refer to the current A71029 drawing and AMM 71-00-02 for complete usage instructions. A71029-36 consists of an A71029-2 left hand assembly and an A71029-36 right hand assembly.

**WEIGHT:** 51 lbs (23 kg)

**DIMENSIONS:** 8 x 27 x 75 inches (203 x 686 x 1905 mm)

**NOTE:** A71029-36 supersedes A71029-1.

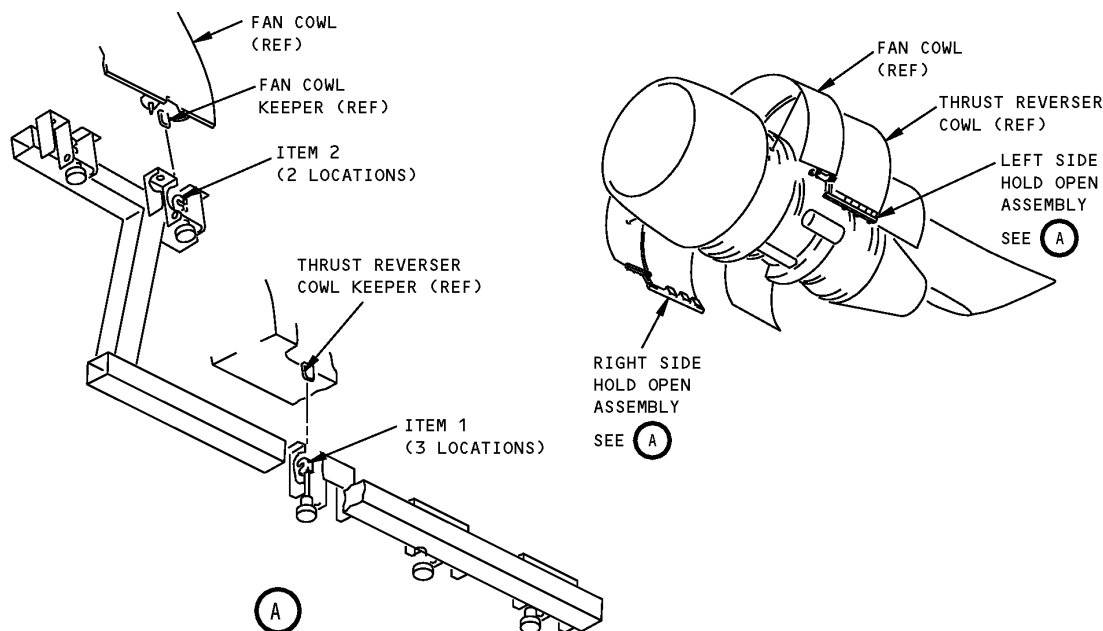

**JT9D-7R4 Engine 20 Knot Fan Cowl Hold Open Equipment  
Figure 1 (Sheet 1 of 2)**

**767**  
**ILLUSTRATED TOOL AND EQUIPMENT MANUAL**

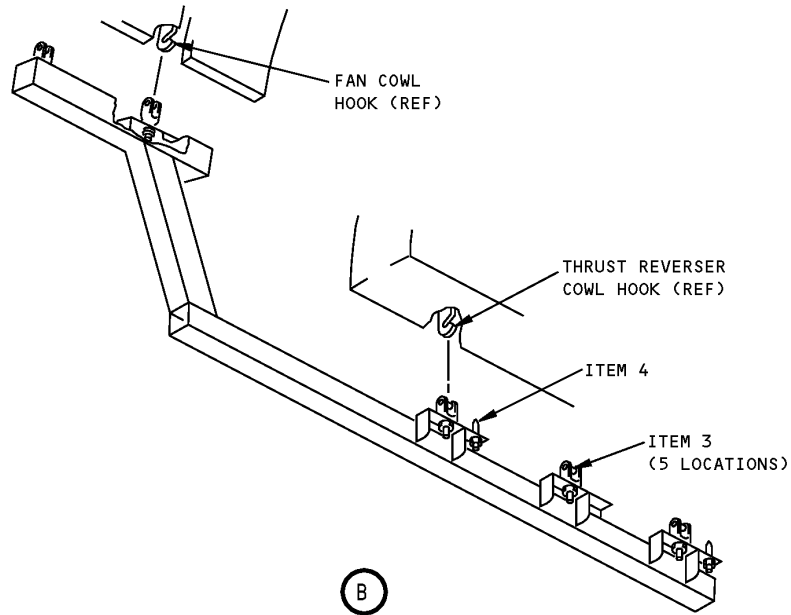

**JT9D-7R4 Engine 20 Knot Fan Cowl Hold Open Equipment**  
**Figure 1 (Sheet 2 of 2)**

<b>REPAIRABLE/REPLACEABLE PARTS</b>			
<b>ITEM NO.</b>	<b>PART NO.</b>	<b>NOMENCLATURE</b>	<b>VENDOR CODE</b>
1	A71029-9	HOOK	
2	A71029-10	HOOK	
3	A71029-12	KEEPER ASSEMBLY	
4	A71029-11	PIN	

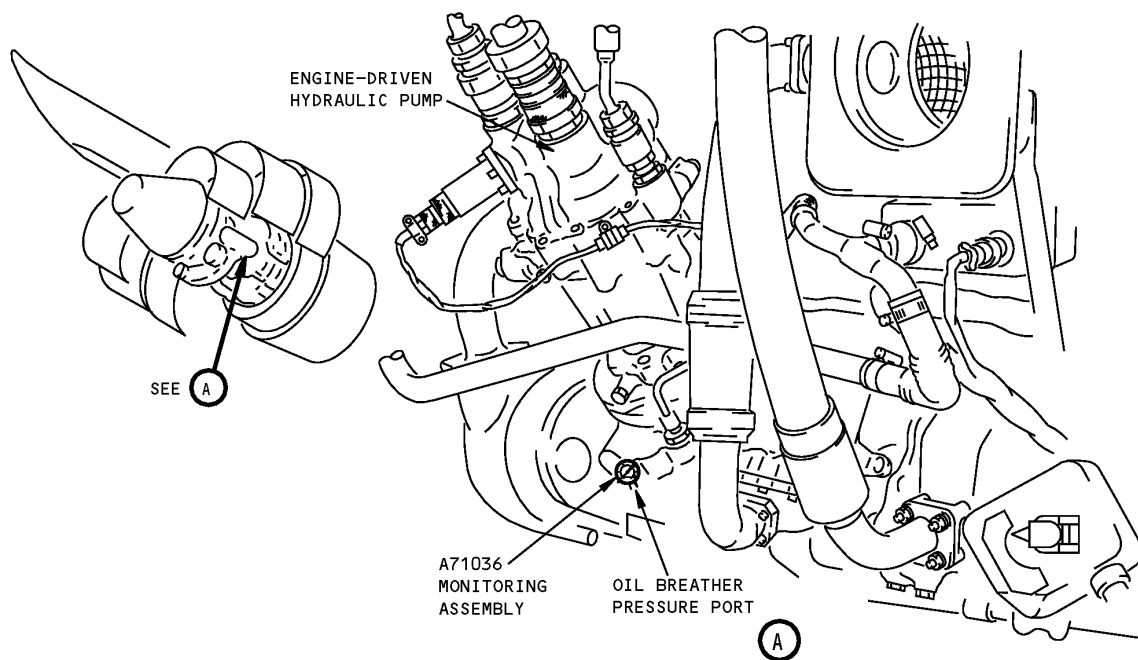

## ILLUSTRATED TOOL AND EQUIPMENT MANUAL

**PART NUMBER: A71036-1****NAME:** MONITORING ASSEMBLY - BREATHER PRESSURE, JT9D-7R4 ENGINE**AIRPLANE MAINTENANCE:** YES**COMPONENT MAINTENANCE:** NO**USAGE & DESCRIPTION:** The A71036-1 monitoring assembly is used on 767 airplanes equipped with JT9D-7R4 engines. A71036 is screwed into the removed oil breather pressure fitting to monitor breather pressure in the engine gearbox. Refer to AMM 71-00-00 and current A71036 drawing for additional usage instructions. A71036-1 consists of an A71036-2 monitoring assembly contained in a storage box.**WEIGHT:** 3 lbs (1.4 kg)**DIMENSIONS:** 2 x 3 x 5 inches (57 x 76 x 127 mm)

**JT9D-7R4 Engine Breather Pressure Monitoring Assembly  
Figure 1**

**ILLUSTRATED TOOL AND EQUIPMENT MANUAL**

**PART NUMBER: A71037-1**

**NAME:** TEST EQUIPMENT - DRYING AND LEAK CHECK, JT9D-7R4D GEARBOX

**AIRPLANE MAINTENANCE:** YES

**COMPONENT MAINTENANCE:** NO

**USAGE & DESCRIPTION:** The A71037 test equipment is used on 767 airplanes equipped with JT9D-7R4D/E engines. A71037 is used to regulate air at 130-150 pounds per hour flow at 10 psi maximum regulated pressure and 325F° (163°C) maximum regulated temperature. A71037 is used in conjunction with a commercial pneumatic start unit. A71037-1 consists of an A71037-2 adapter assembly, an A71037-3 gauge adapter assembly and various plumbing and connecting hardware.

**WEIGHT:** 100 lbs (45 kg)

**DIMENSIONS:** 6 x 11 x 631 inches (152 x 279 x 16,027 mm)

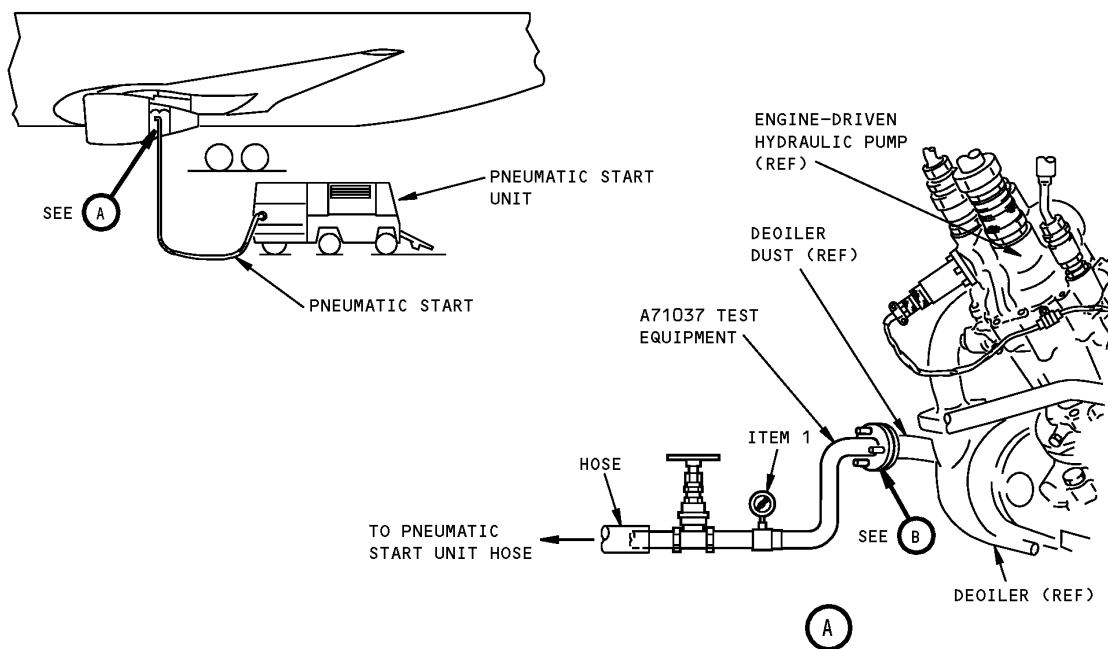

**JT9D-7R4D Gearbox Drying and Leak Check Test Equipment  
Figure 1 (Sheet 1 of 2)**

**767**  
**ILLUSTRATED TOOL AND EQUIPMENT MANUAL**

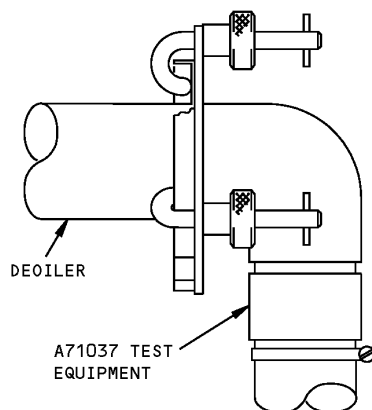

**JT9D-7R4D Gearbox Drying and Leak Check Test Equipment**  
**Figure 1 (Sheet 2 of 2)**

REPAIRABLE/REPLACEABLE PARTS			
ITEM NO.	PART NO.	NOMENCLATURE	VENDOR CODE
1	A71037-6	GAUGE	



767

## ILLUSTRATED TOOL AND EQUIPMENT MANUAL

**PART NUMBER: A71035-1, -13, -27**

**NAME:** COVER EQUIPMENT - BLEED VALVE, GE ENGINE

**AIRPLANE MAINTENANCE:** YES

**COMPONENT MAINTENANCE:** NO

**USAGE & DESCRIPTION:** The A71035-1 cover equipment is used on 767 airplanes equipped with CF6-80A engines. A71035-13 or -27 is used on 767 airplanes equipped with CF6-80C2B engine. This tool is used to cover the variable bleed valves and actuators during engine buildup and storage to prevent foreign objects from entering valve area. Refer to AMM 71-00-00, AMM 71-00-02 and AMM 71-00-03 for complete usage instructions. The A71035-1 and -13 cover equipment consists of neoprene covers with aluminum reinforcing straps held in place by shock cords. The A71035-27 cover equipment consist of vinyl cover held in place with nylon strap and velcro fasteners.

**WEIGHT:**  
A71035-1 - 15 lbs (7 kg)  
A71035-13 - 5 lbs (2 kg)  
A71035-27 - 3 lbs (1.3 kg)

**DIMENSIONS:**  
A71035-1 - 7 x 12 x 40 inches (178 x 305 x 1016 mm)  
A71035-13 - 4 x 12 x 24 inches (102 x 305 x 610 mm)  
A71035-27 - 4 x 9 x 15 inches (102 x 229 x 381 mm)

**NOTE:** A71035-27 replaces A71035-13 for future procurement.

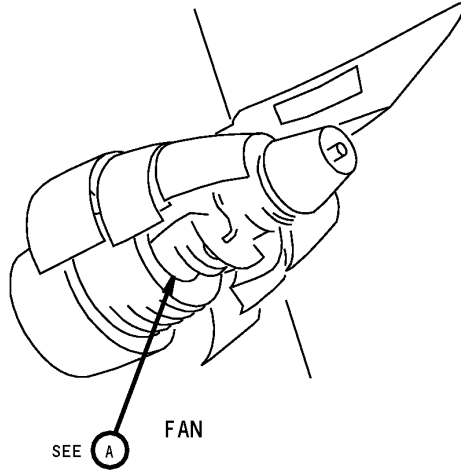

**General Electric Engine Bleed Valve Cover Equipment  
Figure 1 (Sheet 1 of 3)**

**ILLUSTRATED TOOL AND EQUIPMENT MANUAL**

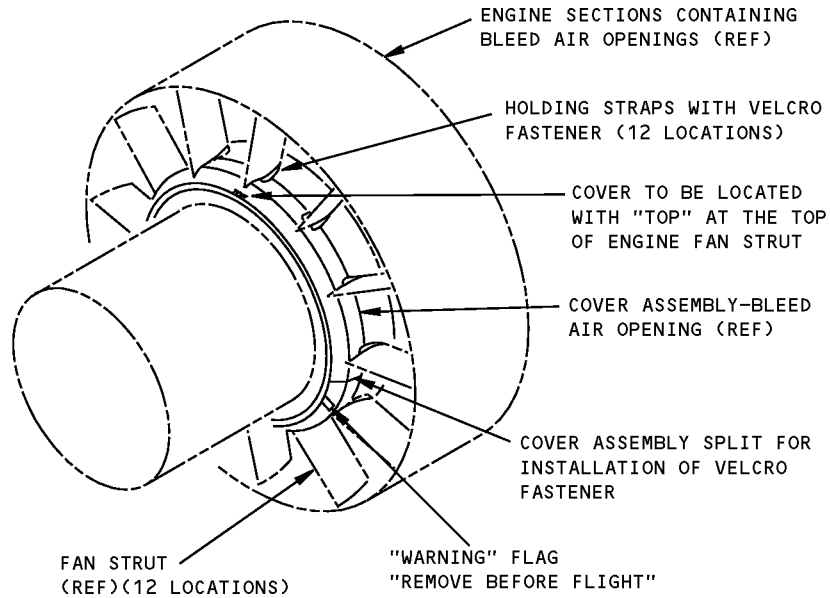
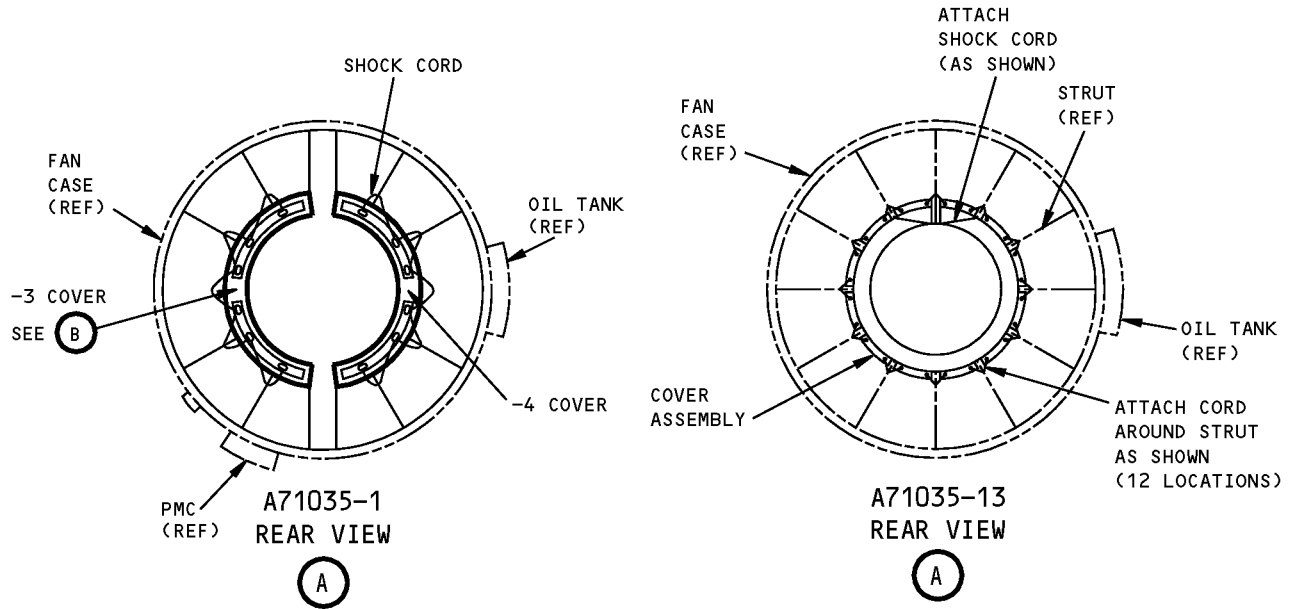

**A71035-27**

(A)

**General Electric Engine Bleed Valve Cover Equipment  
Figure 1 (Sheet 2 of 3)**

**ILLUSTRATED TOOL AND EQUIPMENT MANUAL**

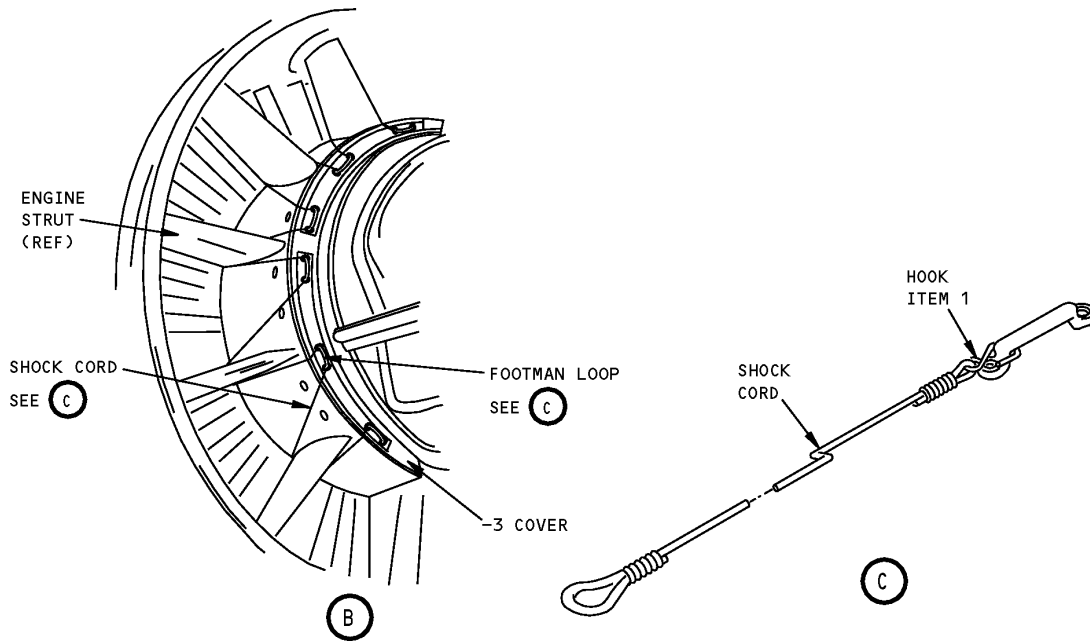

**General Electric Engine Bleed Valve Cover Equipment  
Figure 1 (Sheet 3 of 3)**

REPAIRABLE/REPLACEABLE PARTS			
ITEM NO.	PART NO.	NOMENCLATURE	VENDOR CODE
1	NAS1090-1	HOOK	

## ILLUSTRATED TOOL AND EQUIPMENT MANUAL

**PART NUMBER: A71042-1, -29****NAME:** GUARD - INLET, ENGINE RUN-UP**AIRPLANE MAINTENANCE:** YES**COMPONENT MAINTENANCE:** NO

**USAGE & DESCRIPTION:** The A71042-1 guard is used on airplanes equipped with the JT9D-7R4D or CF6-80A engines. The A71042-29 guard is used on airplanes equipped with the JT9D-7R4D, PW4000, CF6-80A, CF6-80C2 or RB211-524H engines. A71042 is used for personnel protection during engine runup. Refer to AMM 71-00-00 for further usage instructions. A71042-1 consists of a semicircular fence mounted on casters. A towing bar with lunette eye is attached to the assembly.

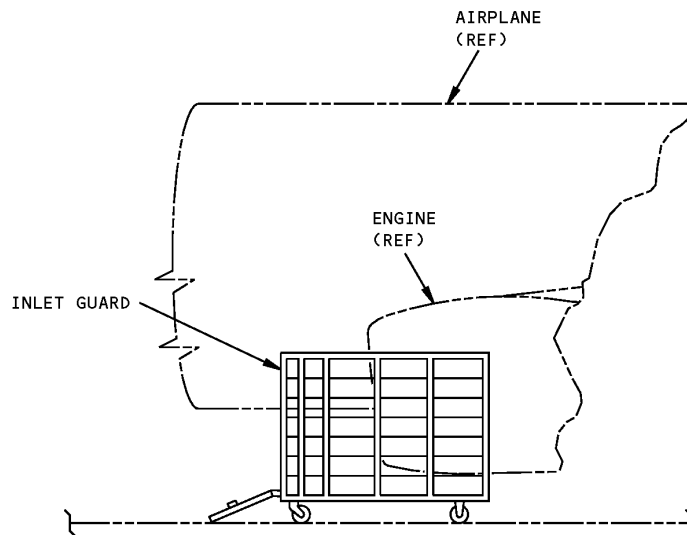
**WEIGHT:** 450 lbs (204 kg)**DIMENSIONS:** 70 x 100 x 130 inches (1778 x 2540 x 3302 mm)**NOTE:** A71042-29 replaces A71042-1 for future procurement.

**Engine Run-Up Inlet Guard  
Figure 1**



## ILLUSTRATED TOOL AND EQUIPMENT MANUAL

**PART NUMBER:** PWA 25056, 25757, 25758, 29245

**NAME:** EQUIPMENT - ENGINE SUPPORT

**AIRPLANE MAINTENANCE:** NO

**COMPONENT MAINTENANCE:** YES

**USAGE & DESCRIPTION:** This tool is used to support the P & W JT9D engine on each four sides during overhaul. There are two PWA 25056 brackets, two PWA 29243 brackets, three PWA 25926 adapters, three PWA 25757 fixed pedestals, and one PWA 25758 adjustable pedestal. The PWA 25758 adjustable pedestal is used on one side of the engine only, and can be adjusted to ensure the proper level of the engine on ground. This tool is a supplier proprietary item and can only be obtained from United Technologies Corporation, Pratt & Whitney Aircraft Group, 400 Main Street, E. Hartford, Connecticut 06108.

**DIMENSIONS:**  
PWA 25926 - 5 x 2 x 5 inches (127 x 51 x 127 mm)  
PWA 25757 - 24 x 3 x 48 inches (610 x 76 x 1219 mm)  
PWA 25758 - 24 x 3 x 60 inches (610 x 76 x 1524 mm)

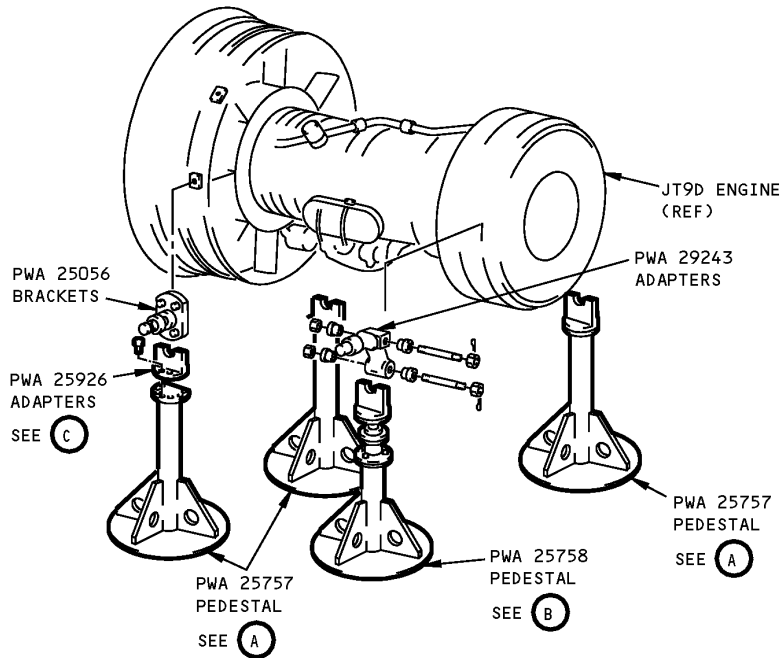

**Engine Support Equipment  
Figure 1 (Sheet 1 of 2)**

**ILLUSTRATED TOOL AND EQUIPMENT MANUAL**

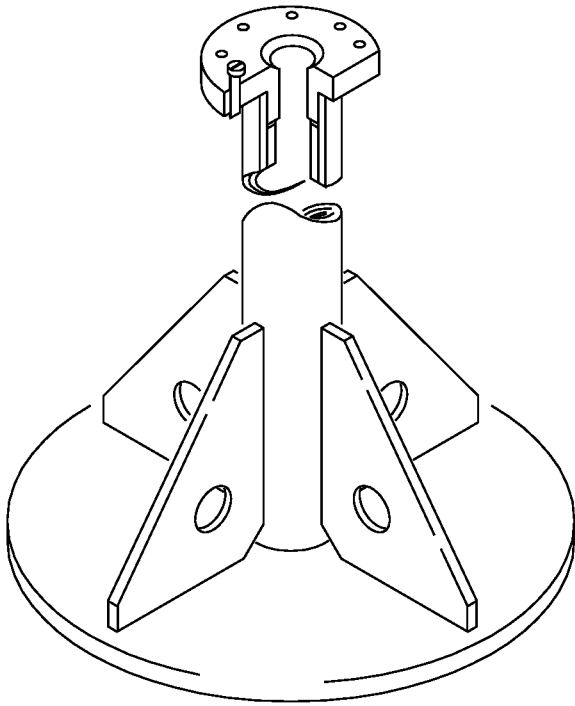

PWA 25757 PEDESTAL (FIXED)

(A)

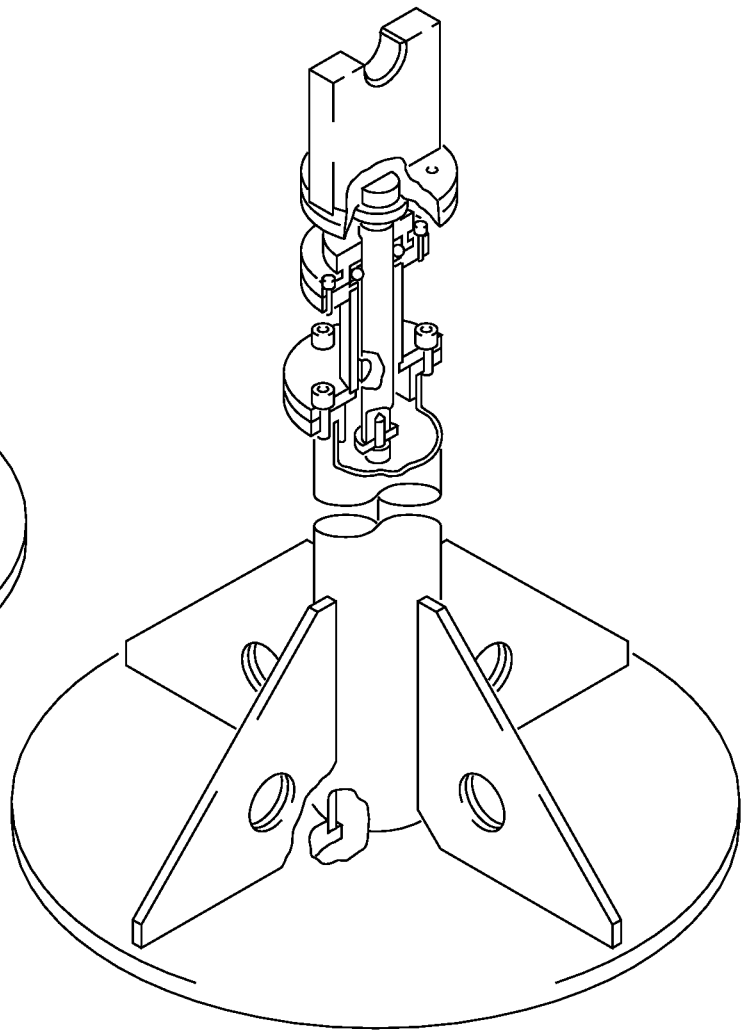

PWA 25758 PEDESTAL (ADJUSTABLE)

(B)

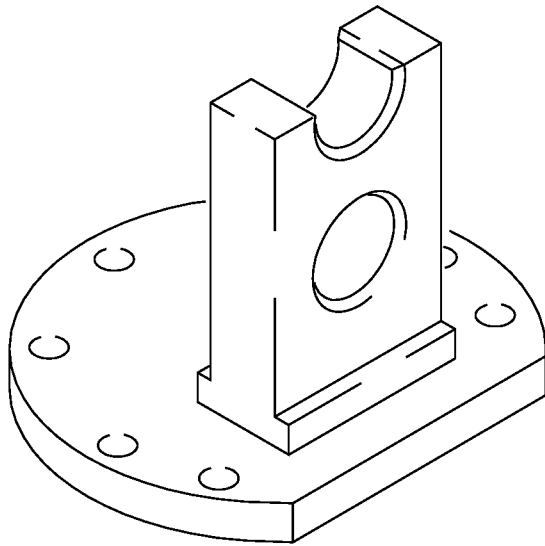

PWA 25926 ADAPTERS

(C)

**Engine Support Equipment  
Figure 1 (Sheet 2 of 2)**

## ILLUSTRATED TOOL AND EQUIPMENT MANUAL

**PART NUMBER: A71005-33****NAME:** SLING EQUIPMENT - ENGINE INLET COWL**AIRPLANE MAINTENANCE:** YES**COMPONENT MAINTENANCE:** NO

**USAGE & DESCRIPTION:** The A71005-33 is used on 767 airplanes equipped with CF6-80A, JT9D-7R4D and PW4000 engines. A71005 provides capabilities for lift, controlled rotation and pitch, while removing or installing inlet cowl to or from the shipping container, and removing or installing inlet cowl to or from the airplane engine. Refer to AMM 71-11-01 for complete usage instructions. The A71005-33 consists of an A71005-35 sling assembly, three A71005-34 strap assemblies, three 234B lever hoists, all contained in a storage box.

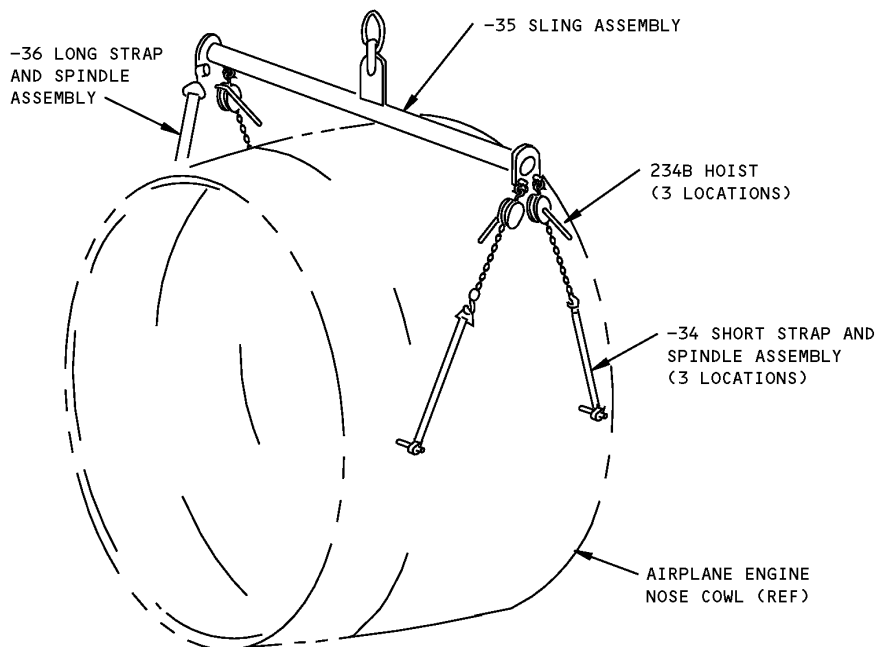
**WEIGHT:** 130 lbs (59 kg)**DIMENSIONS:** 12 x 16 x 120 inches (305 x 406 x 3048 mm)**NOTE:** A71005-33 supersedes A71005-31 and A71005-25.

**Engine Inlet Cowl Sling Equipment  
Figure 1 (Sheet 1 of 2)**

ILLUSTRATED TOOL AND EQUIPMENT MANUAL

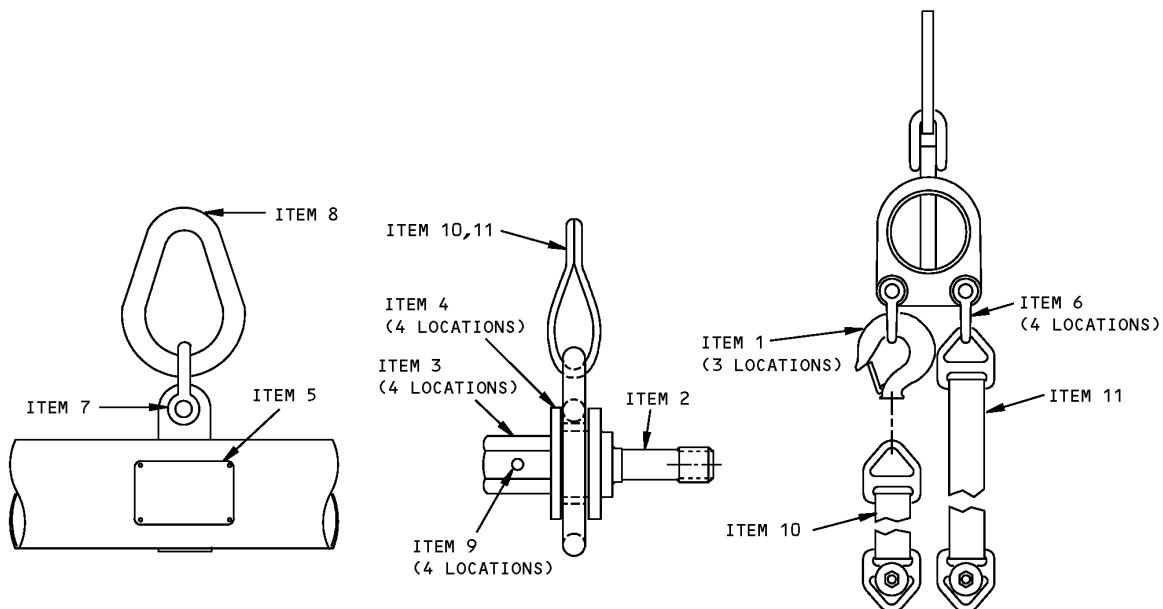

Engine Inlet Cowl Sling Equipment  
Figure 1 (Sheet 2 of 2)

REPAIRABLE/REPLACEABLE PARTS			
ITEM NO.	PART NO.	NOMENCLATURE	VENDOR CODE
1	234B	LEVER HOIST	V54399
2	A71005-9	SPINDLE	
3	A71005-10	NUT	
4	A71005-11	WASHER	
5	F70308-15	PROOF LOAD TAG	
6	G-213-1/2	SHACKLE	V75535
7	G-215-3/4	SHACKLE	V75535
8	G-341-3/4	SLING LINK	V75535
9	MS16562-34	SPRING PIN	
10	A71005-38	SHORT STRAP ASSEMBLY	V95957
11	A71005-39	LONG STRAP ASSEMBLY	V95957

**ILLUSTRATED TOOL AND EQUIPMENT MANUAL**

**PART NUMBER: A71040**

**NAME:** SPECIFICATION - FLUSH CART, ENGINE INTEGRATED DRIVE GENERATOR (IDG) COOLING SYSTEM

**AIRPLANE MAINTENANCE:** YES

**COMPONENT MAINTENANCE:** NO

**USAGE & DESCRIPTION:** The A71040 flush cart is designed to service all 767 airplanes. The flush cart includes an electric motor-driven pump, flow control valve, direction control valve, cooler, pressure relief valve, system filter, flow meter, hoses, a patch filter, and provisions for purging the IDG cooling system. The purpose of this system is to flush the IDG cooling System on an engine. The system supplies dry cleaning solvent at 250 psig (max) and 17 gpm (min) to the IDG cooling system through hoses attached to the cart. It is to be used on a flight-line or in a hangar or shop.

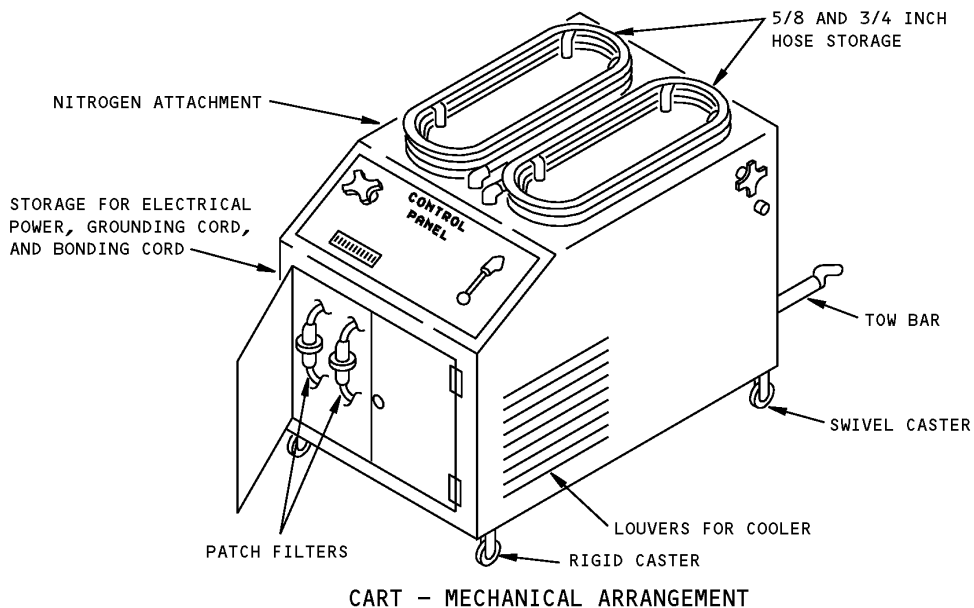

**Engine Integrated Drive Generator Cooling System Flush Cart  
Figure 1**

**ILLUSTRATED TOOL AND EQUIPMENT MANUAL**

**PART NUMBER: G71007-28**

**NAME:** SLING EQUIPMENT - INLET COWL, CF6-80C2B ENGINE

**AIRPLANE MAINTENANCE:** YES

**COMPONENT MAINTENANCE:** NO

**USAGE & DESCRIPTION:** The G71007 sling equipment is used on 767-200ER, -300, -300ER and -400 airplanes equipped with CF6-80C2B engines. G71007 is used to remove or install the inlet cowl of the CF6-80C2B engine. Refer to AMM 71-11-01 for complete usage instructions. G71007-28 consists of a G71007-30 sling assembly, a G71007-19 inboard bracket assembly, a G71007-18 outboard bracket assembly, all contained in a storage box.

**WEIGHT:** 36 lbs (16 kg)

**DIMENSIONS:** 8 x 12 x 107 inches (203 x 305 x 2718 mm)

**NOTE:** G71007-28 supersedes G71007-16.

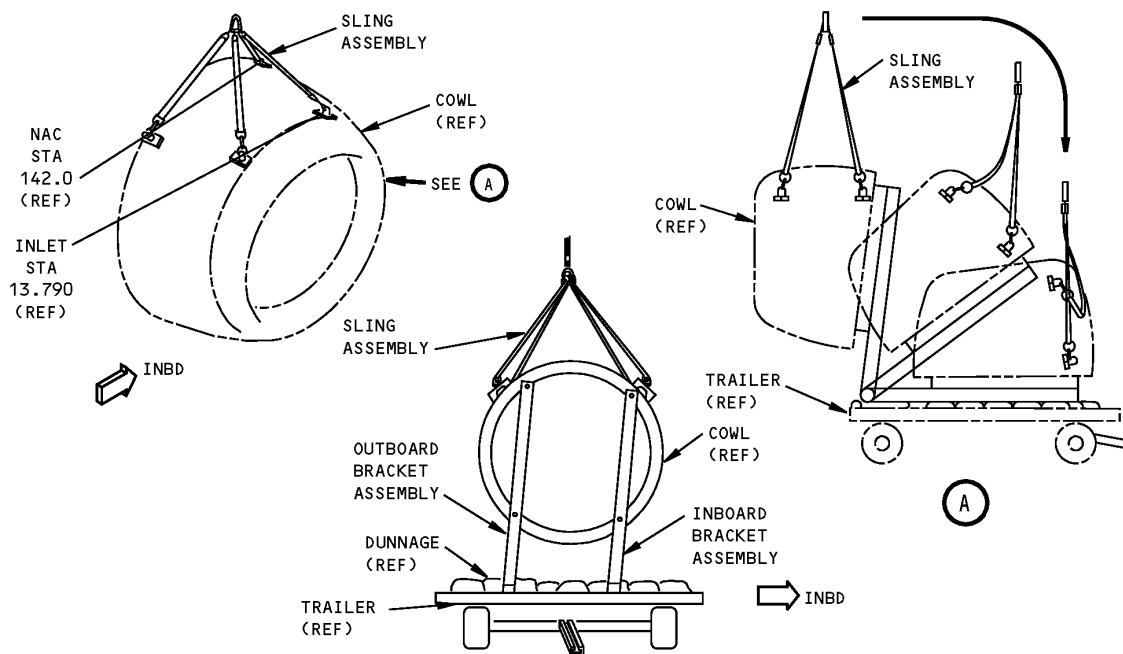

**CF6-80C2B Engine Inlet Cowl Sling Equipment  
Figure 1**



767

**ILLUSTRATED TOOL AND EQUIPMENT MANUAL**

**PART NUMBER: 2C6339G05/06 WAS DELETED**



767

## ILLUSTRATED TOOL AND EQUIPMENT MANUAL

**PART NUMBER: G71008-1**

**NAME:** PROOF LOAD EQUIPMENT - CRADLE, CF6-80C2B ENGINE

**AIRPLANE MAINTENANCE:** NO

**COMPONENT MAINTENANCE:** YES

**USAGE & DESCRIPTION:** The G71008-1 proof load equipment is used to proof load the G71002 engine cradle, which is used on 767 airplanes equipped with CF6-80C2B engines. Refer to the current G71002 and G71008 drawing for complete usage instructions. G71008-1 consists of a G71008-2 load beam assembly, a G71008-3 forward beam assembly and a G71008-4 aft beam assembly.

**WEIGHT:** 800 lbs (363 kg)

**DIMENSIONS:** 20 x 36 x 125 inches (508 x 914 x 3175 mm)



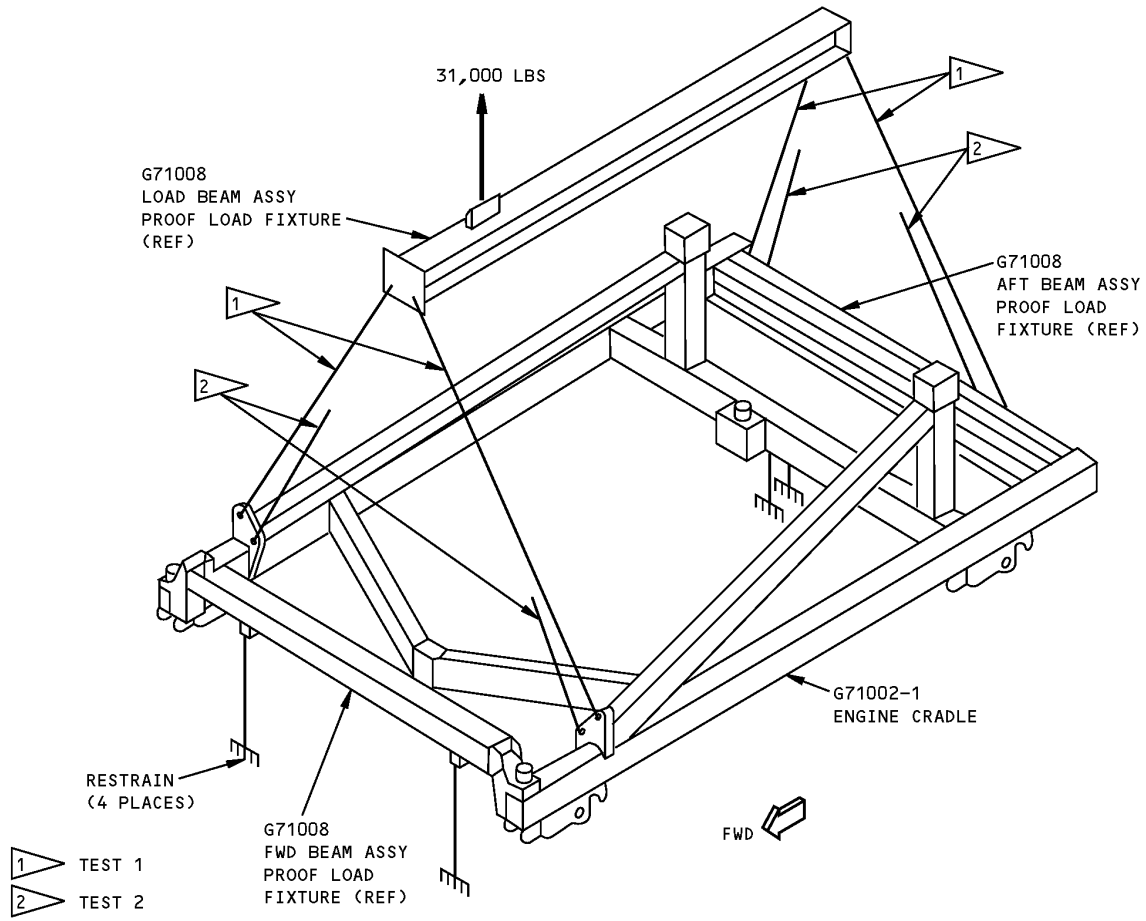

**CF6-80C2B Engine Cradle Proof Load Equipment  
Figure 1**

767  
ILLUSTRATED TOOL AND EQUIPMENT MANUAL

**PART NUMBER: G71002-48**

**NAME:** CRADLE - CF6-80C2B ENGINE

**AIRPLANE MAINTENANCE:** NO

**COMPONENT MAINTENANCE:** YES

**USAGE & DESCRIPTION:** The G71002-48 cradle is used on all 767 airplanes equipped with CF6-80C2B engines. G71002 is used to support the engine during transportation and bootstrap installation. G71002-48 consists of a G71002-49 frame assembly, two G71002-34 forward adapter assemblies and a G71002-35 pin assembly.

**WEIGHT:** 1700 lbs (771 kg)

**DIMENSIONS:** 60 x 105 x 145 inches (1524 x 2667 x 3683 mm)

**NOTE:** G71002-48 supersedes G71002-45.

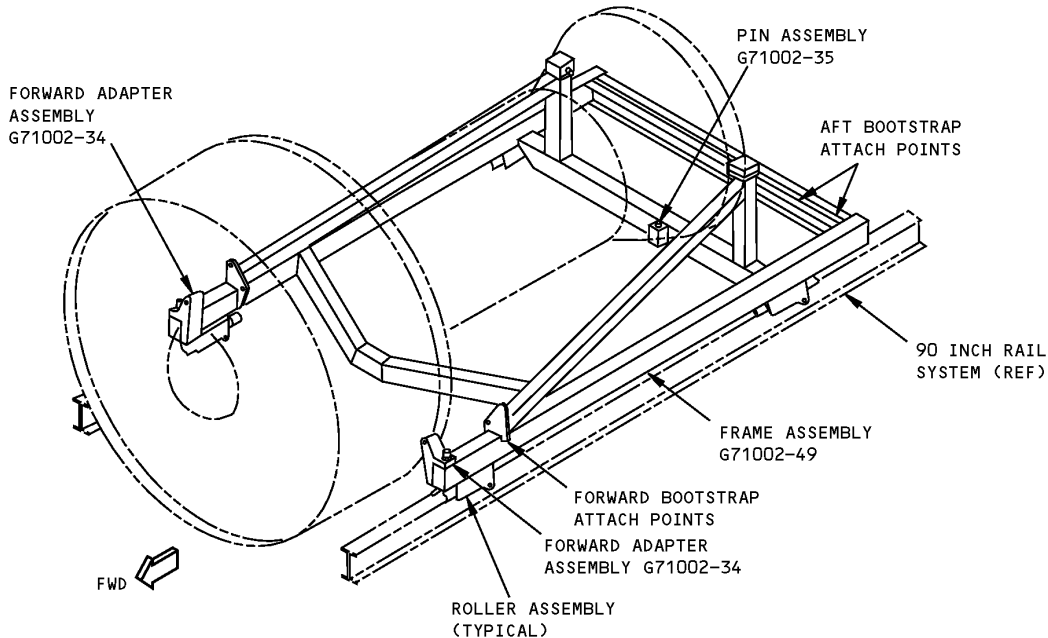

**CF6-80C2B Engine Cradle  
Figure 1**



767

## ILLUSTRATED TOOL AND EQUIPMENT MANUAL

**PART NUMBER: G71010-79, -80, -81**

**NAME:** SLING - ENGINE HANDLING, GE ENGINES

**AIRPLANE MAINTENANCE:** NO

**COMPONENT MAINTENANCE:** YES

**USAGE & DESCRIPTION:** The G71010-79,-80 or -81 slings are used during component maintenance on 767 airplanes equipped with GE engines. G71010-79 is used for airlines that include both CF6-80A and CF6-80C2 engines in their 767 fleet. G71010-80 is used for airlines with only CF6-80C2 engines in their 767 fleet. G71010-81 is used for airlines with only CF6-80A engines in their 767 fleet. G71010-80 may be converted to G71010-79 by adding a G71010-85 pad link assembly. G71010-81 may be converted to G71010-79 by adding a G71010-84 spreader bar. The G71010 sling is used to transport GE engines between fixtures. Refer to the current G71010 drawing for complete usage instructions. The G71010 sling consists of:

G71010-79		
QUANTITY	NOMENCLATURE	PART NUMBER
1	BEAM ASSEMBLY	G71010-83
1	SPREADER BAR ASSEMBLY	G71010-84
1	PAD LINK ASSEMBLY	G71010-85
1	CRANK ASSEMBLY	G71010-46
1	CRANK HANDLE	G71010-55
1	STORAGE BOX	

G71010-80		
QUANTITY	NOMENCLATURE	PART NUMBER
1	BEAM ASSEMBLY	G71010-83
1	SPREADER BAR ASSEMBLY	G71010-84
1	CRANK ASSEMBLY	G71010-46
1	CRANK HANDLE	G71010-55
1	STORAGE BOX	

G71010-81		
QUANTITY	NOMENCLATURE	PART NUMBER
1	BEAM ASSEMBLY	G71010-83
1	PAD LINK ASSEMBLY	G71010-85
1	CRANK ASSEMBLY	G71010-46

**767**  
**ILLUSTRATED TOOL AND EQUIPMENT MANUAL**

G71010-81		
QUANTITY	NOMENCLATURE	PART NUMBER
1	CRANK HANDLE	G71010-55
1	STORAGE BOX	

**WEIGHT:** 700 lbs (318 kg)

**DIMENSIONS:** 32 x 50 x 130 inches (813 x 1270 x 3302 mm)

**NOTE:** G71010-79, -80 and -81 supersede G71010-67, -68 and -69 respectively. G71010 replaces A71019 for future procurement.

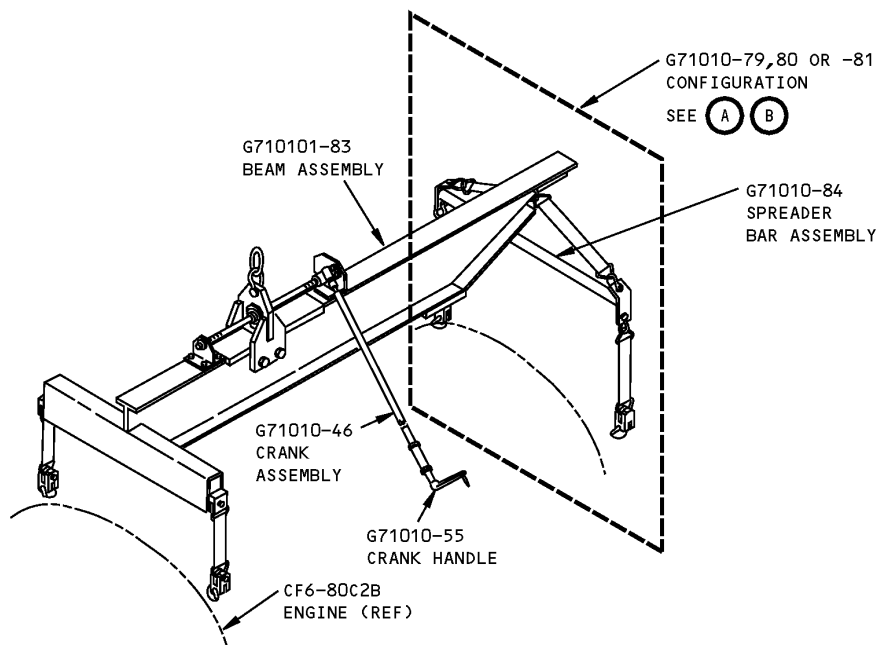

**General Electric Engines, Engine Handling Sling  
Figure 1 (Sheet 1 of 2)**

**ILLUSTRATED TOOL AND EQUIPMENT MANUAL**

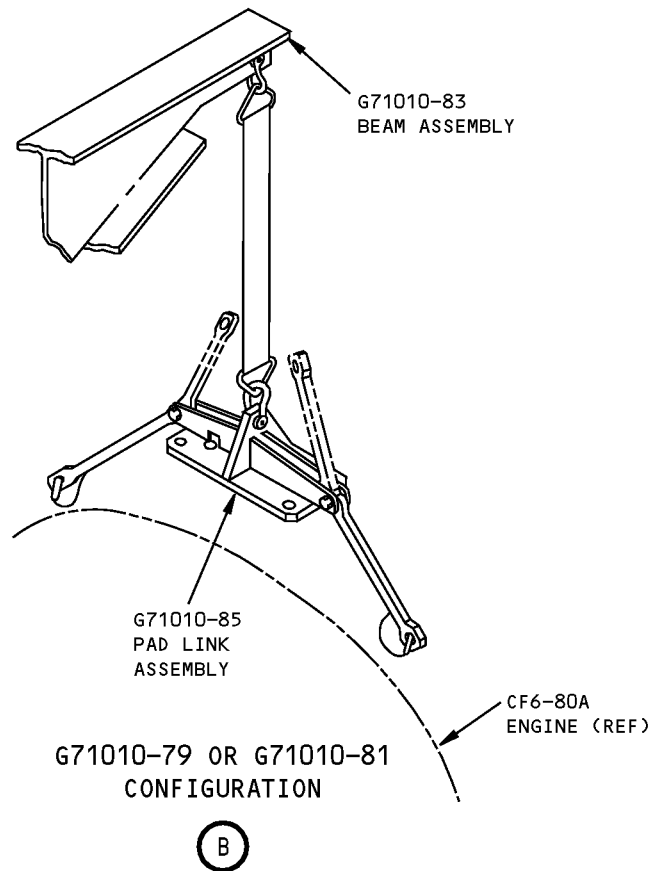
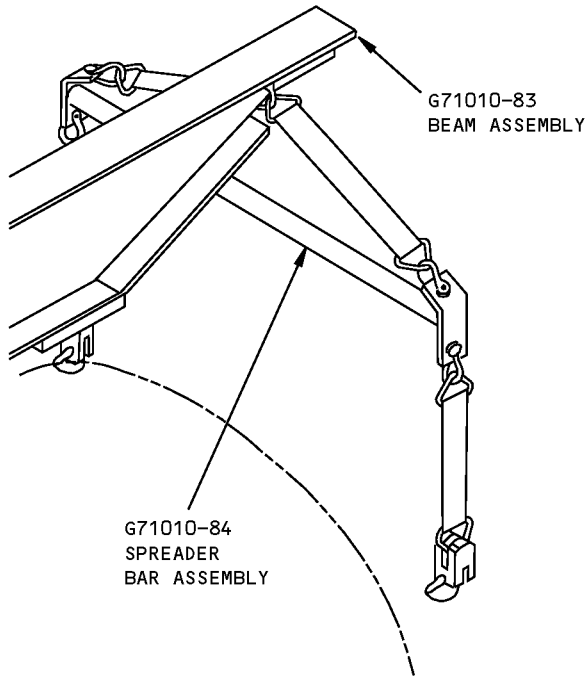

**General Electric Engines, Engine Handling Sling  
Figure 1 (Sheet 2 of 2)**

## ILLUSTRATED TOOL AND EQUIPMENT MANUAL

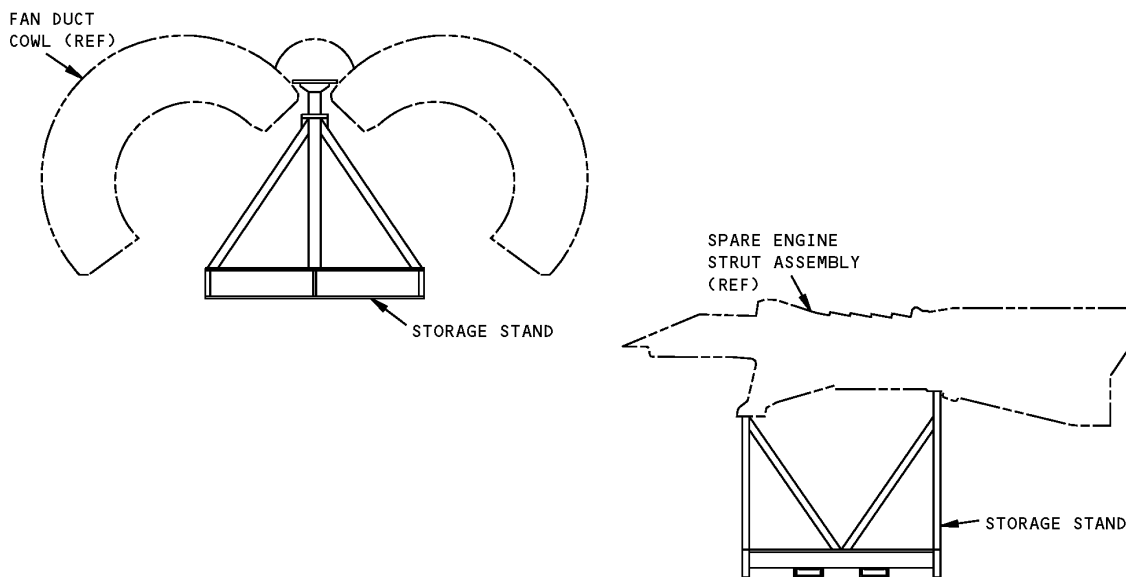
**PART NUMBER: A71045-1****NAME:** STORAGE STAND - SPARE ENGINE CARRIAGE**AIRPLANE MAINTENANCE:** NO**COMPONENT MAINTENANCE:** YES**USAGE & DESCRIPTION:** The A71045 storage stand is used on 767 airplanes equipped with JT9D-7R4D/E engines. A71045 is used to store JT9D-7R4D/E spare engine carriage complete with thrust reversers. A71045-1 consists of an A71045-2 storage stand assembly, an A71045-3 saddle assembly and various connecting hardware.**WEIGHT:** 1400 lbs (635 kg)**DIMENSIONS:** 70 x 84 x 84 inches (1778 x 2134 x 2134 mm)

**Spare Engine Carriage Storage Stand  
Figure 1**



767

## ILLUSTRATED TOOL AND EQUIPMENT MANUAL

**PART NUMBER: G71012-107, -118, -119**

**NAME:** LOCATING JIG - ENGINE BUILDUP TO STRUT, CF6-80C2B ENGINE

**AIRPLANE MAINTENANCE:** NO

**COMPONENT MAINTENANCE:** YES

**USAGE & DESCRIPTION:** The G71012-118 locating jig is used on engines equipped with power management control (PMC) and the G71012-119 locating jig is used on engines equipped with full authority digital control (FADEC). The G71012-107 jig stand equipment is used for storing either the G71012-118 or -119 locating jigs. G71012 is used to support and align engine systems during engine buildup for correct mating to strut. G71012-118 and -119 consist of a strong back assembly, a starter duct locator assembly, a pressure relief valve sensor locating assembly, raceway assembly, ECS forward precooler locating assembly, a duct locating assembly, a vent locating assembly, a raceway locating assembly, locating rod assemblies, a location bar assembly, a raceway assembly, a pad assembly and related hardware. G71012-107 consists of a forward stand assembly and aft stand assembly.

**WEIGHT:** 95 lbs (43 kg)

**DIMENSIONS:** 30 x 58 x 140 inches (762 x 1473 x 3556 mm)

**NOTE:** G71012-118 and -119 supersede G71012-3 and -4 respectively.

**ILLUSTRATED TOOL AND EQUIPMENT MANUAL**

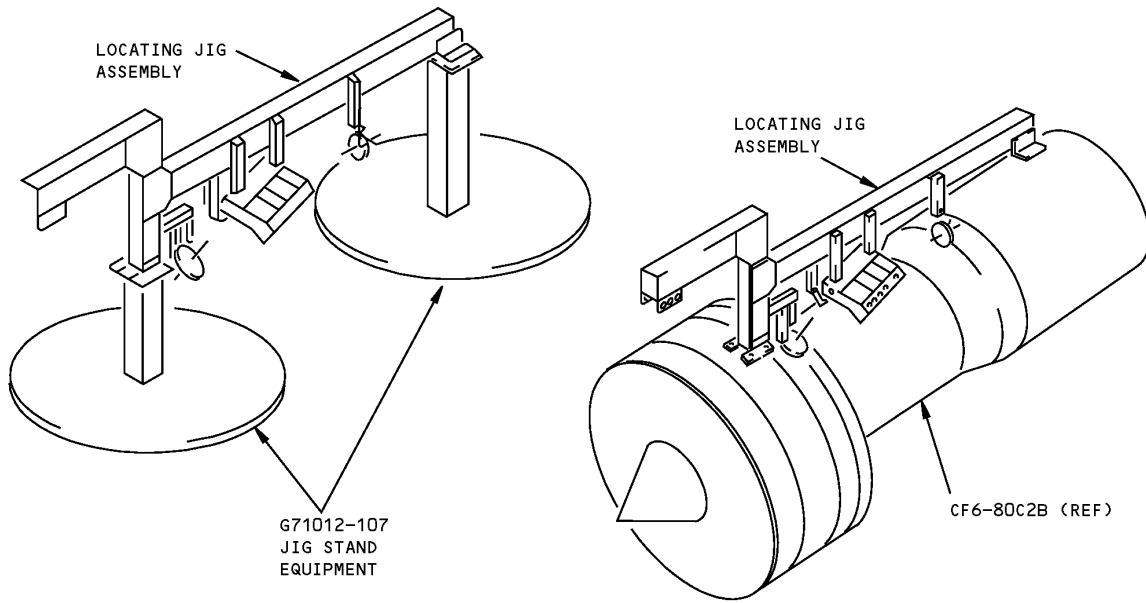

**CF6-80C2B Engine Buildup to Strut Locating Jig  
Figure 1**



## ILLUSTRATED TOOL AND EQUIPMENT MANUAL

**PART NUMBER: G71014-1****NAME:** BEAM - ENGINE HANDLING, RB211-524**AIRPLANE MAINTENANCE:** NO**COMPONENT MAINTENANCE:** YES

**USAGE & DESCRIPTION:** The G71014-1 beam is used on 767 airplanes equipped with RB211-524 engines. G71014 is used to transfer a Rolls Royce RB211-524 engine from a shipping stand to engine shop handling equipment. refer to the current G71014 drawing for complete usage instructions. G71014-1 consists of a G71014-2 spreader beam, a G71014-1 counterweight assembly, a G71014-10 forward attach fitting, a G71014-11 aft attach fitting, a G71014-24 cable assembly, a G71014-26 cable assembly and various connecting hardware.

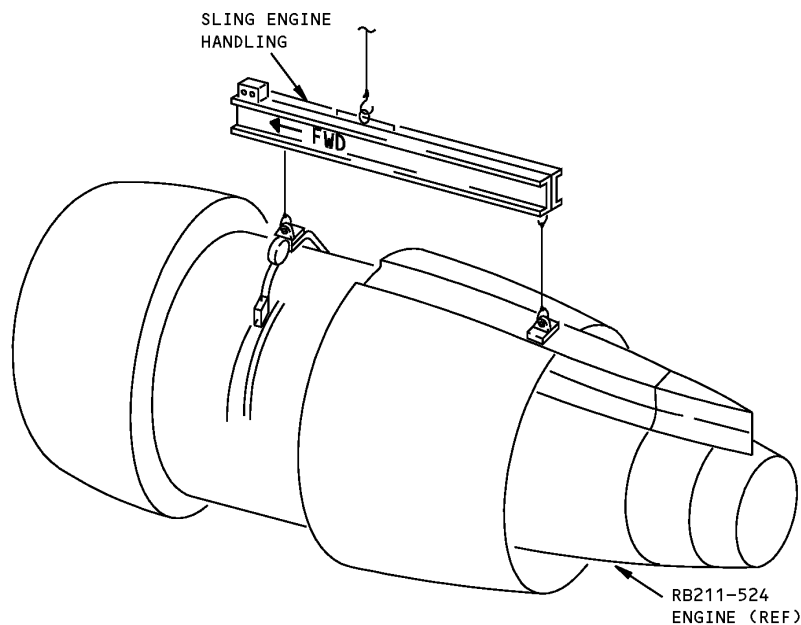
**WEIGHT:** 750 lbs (340 kg)**DIMENSIONS:** 8 x 20 x 114 inches (203 x 508 x 2896 mm)

**Engine Handling Sling  
Figure 1**

ILLUSTRATED TOOL AND EQUIPMENT MANUAL

PART NUMBER: G71013-1

**NAME:** SLING - FAN COWL, CF6-80C2B ENGINE

**AIRPLANE MAINTENANCE:** YES

**COMPONENT MAINTENANCE:** NO

**USAGE & DESCRIPTION:** The G71013-1 sling is used on 767 airplanes equipped with CF6-80C2B engines. G71013 is used to remove and install the CF6-80C2B fan cowl in conjunction with B71016 hoist/transporter or with overhead hoisting equipment. Refer to AMM 71-11-04 for complete usage instructions. G71013-1 consists of a G71013-2 sling assembly contained in a storage box.

**WEIGHT:** 10 lbs (5 kg)

**DIMENSIONS:** 10 x 10 x 32 inches (254 x 254 x 813 mm)

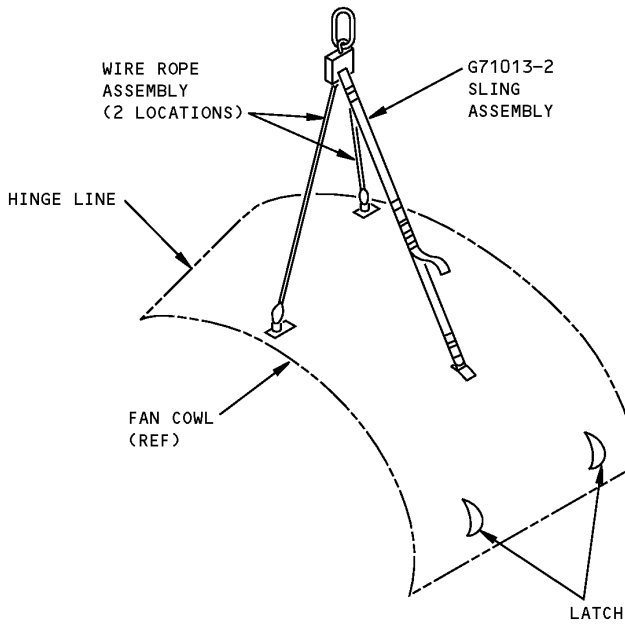

**CF6-80C2B Engine Fan Cowl Sling  
Figure 1**

**ILLUSTRATED TOOL AND EQUIPMENT MANUAL**

**PART NUMBER: G71020-1**

**NAME:** WRENCH - FLEX NUT, 15TH STAGE, MANIFOLD AND DUCT, PW4000

**AIRPLANE MAINTENANCE:** YES

**COMPONENT MAINTENANCE:** NO

**USAGE & DESCRIPTION:** The G71020-1 wrench is used on 767 airplanes equipped with PW4000 engines. G71020 is used to tighten the flex nuts on engine duct ball joints. Refer to the current G71020 drawing for complete usage instructions. The G71020-1 consists of a G71020-2 wrench contained in a storage box.

**WEIGHT:** 0.7 lb (0.3 kg)

**DIMENSIONS:** 0.5 x 4 x 7.5 inches (13 x 102 x 191 mm)

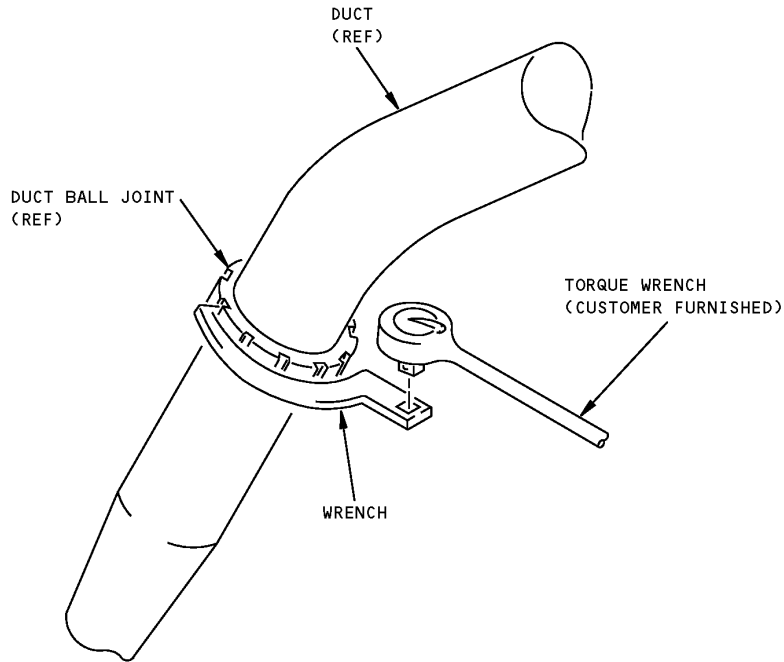

**PW4000, 15th Stage Manifold and Duct, Flex Nut Wrench  
Figure 1**

## ILLUSTRATED TOOL AND EQUIPMENT MANUAL

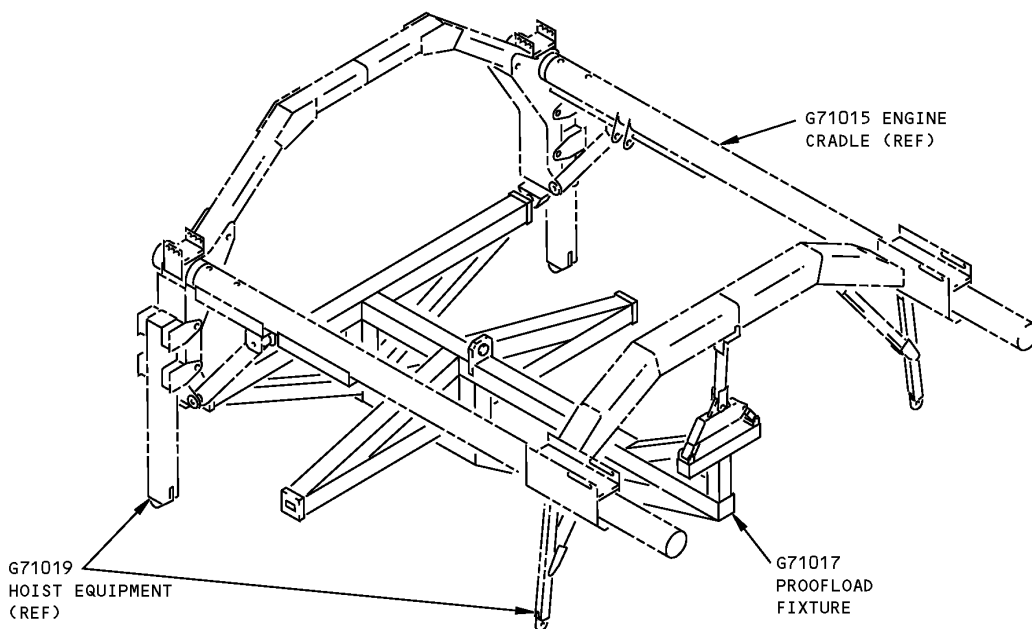
**PART NUMBER: G71017-1****NAME:** PROOF LOAD FIXTURE - RB211-524 ENGINE**AIRPLANE MAINTENANCE:** YES**COMPONENT MAINTENANCE:** NO**USAGE & DESCRIPTION:** The G71017-1 proof load fixture is used to proof load the G71015 engine cradle, used on 767 airplanes equipped with RB211-524 engines. Refer to the current G71017 and G71015 drawings for complete usage instructions. G71015-1 is a weldment with attaching hardware.**WEIGHT:** 750 lbs (340 kg)**DIMENSIONS:** 37 x 87 x 95 inches (940 x 2210 x 2413 mm)

**RB211-524 Engine Proof Load Fixture  
Figure 1**



767

## ILLUSTRATED TOOL AND EQUIPMENT MANUAL

**PART NUMBER: G71018-1**

**NAME:** SUPPORT EQUIPMENT - RB211-524 ENGINE, H2 HANDLING ATTACHMENT

**AIRPLANE MAINTENANCE:** YES

**COMPONENT MAINTENANCE:** NO

**USAGE & DESCRIPTION:** The G71018-1 support equipment is used on 767 airplanes equipped with RB211-524 engines. G71018 is used to support the RB211-524 engine on the G71015-1 engine cradle during engine change or engine buildup. G71018 supports the engine at the H2 handling attachment when the H3 handling attachment is inaccessible. Refer to the current G71018 drawing for complete usage instructions. G71018-1 consists of:

G71018-1		
QUANTITY	NOMENCLATURE	PART NUMBER
2	SUPPORT COLUMN ASSEMBLY	G71018-2
2	RETAINER STOP ASSEMBLY	G71018-11
2	TRUNNION ASSEMBLY	G71018-23
1	BELL CRANK ASSEMBLY	G71018-28
1	STORAGE BOX	

**WEIGHT:** 162 lbs (73 kg)

**DIMENSIONS:** 12 x 28 x 65 inches (305 x 711 x 1651 mm)

**ILLUSTRATED TOOL AND EQUIPMENT MANUAL**

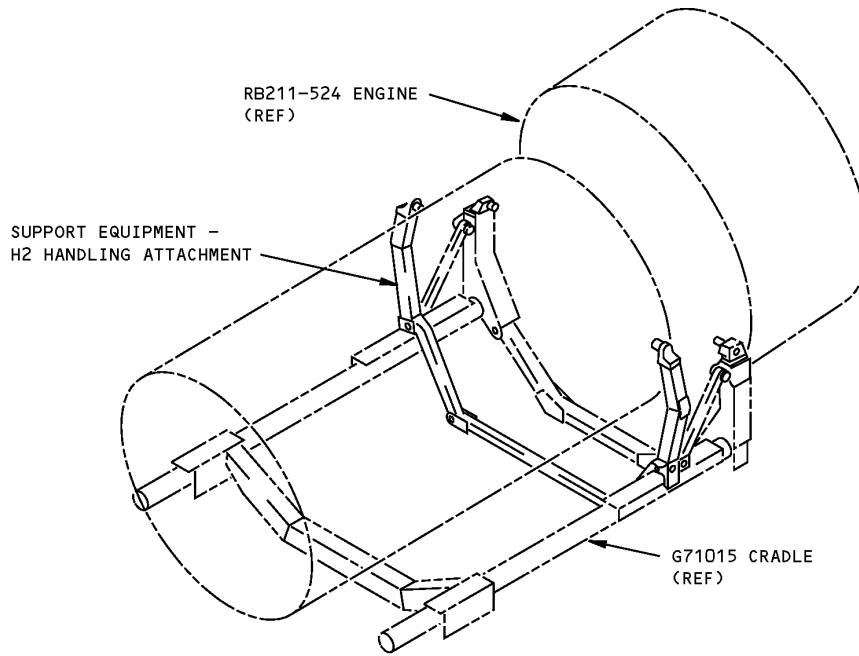

**RB211-524 Engine H2 Handling Attachment Support Equipment  
Figure 1**



767

## ILLUSTRATED TOOL AND EQUIPMENT MANUAL

**PART NUMBER: G71015-75**

**NAME:** CRADLE - RB211-524 (G AND H) ENGINE

**AIRPLANE MAINTENANCE:** YES

**COMPONENT MAINTENANCE:** YES

**USAGE & DESCRIPTION:** The G71015-75 cradle is used on 767 airplanes equipped with RB211-524G/H engines. G71015 is a structural steel cradle that is used with a 90-inch rail stand for storage, transportation and installation and removal of the RB211-524G/H engine. Refer to the current G71015 drawing for complete usage instructions.

G71015-75		
QUANTITY	NOMENCLATURE	PART NUMBER
1	FORWARD YOKE ASSEMBLY	G71015-76
1	AFT YOKE ASSEMBLY	G71015-77
1	AFT SUPPORT ASSEMBLY	G71015-78
2	TRUNNION ASSEMBLY	G71015-79
1	SELF ALIGNING BEARING	MS14103-12
4	BOLT	NAS6610-11

**WEIGHT:** 1400 lbs (635 kg)

**DIMENSIONS:** 56 x 100 x 133 inches (1422 x 2540 x 3378 mm)

**NOTE:** G71015-75 supersedes G71015-1.

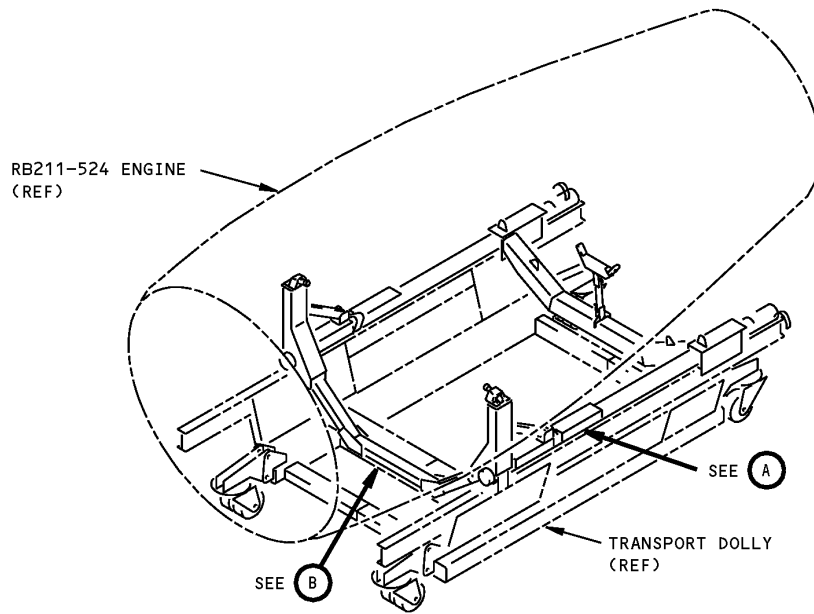

**RB211-524 G/H Engine Cradle  
Figure 1 (Sheet 1 of 3)**



**767**  
**ILLUSTRATED TOOL AND EQUIPMENT MANUAL**

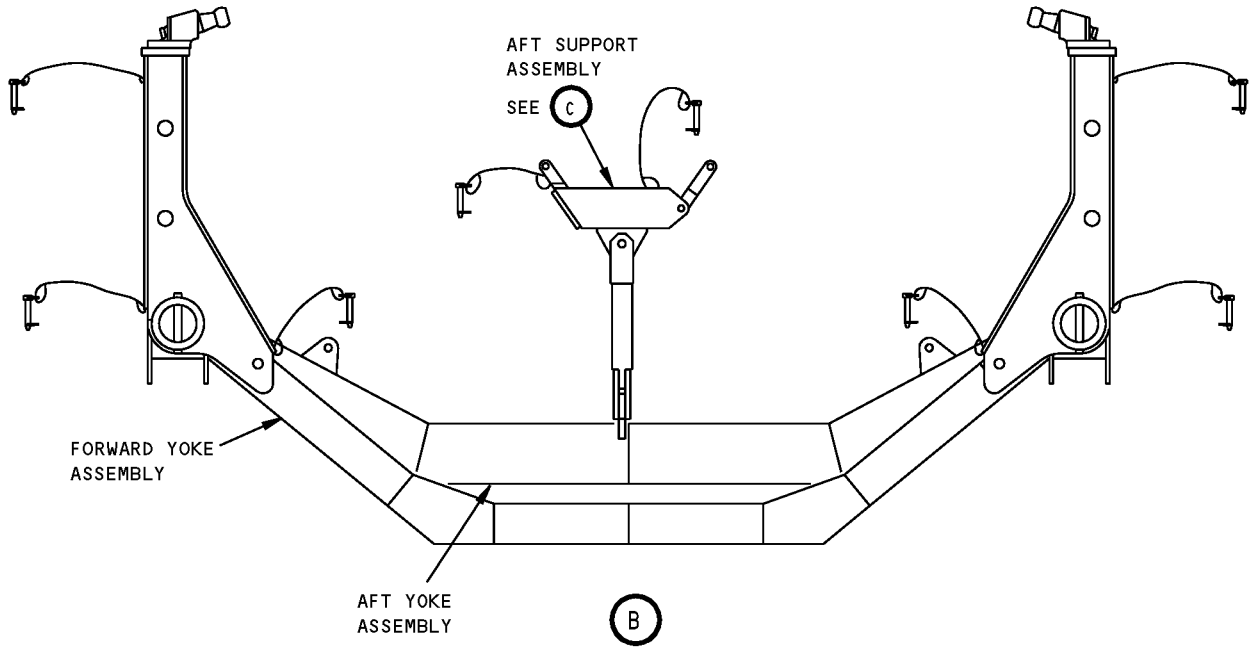
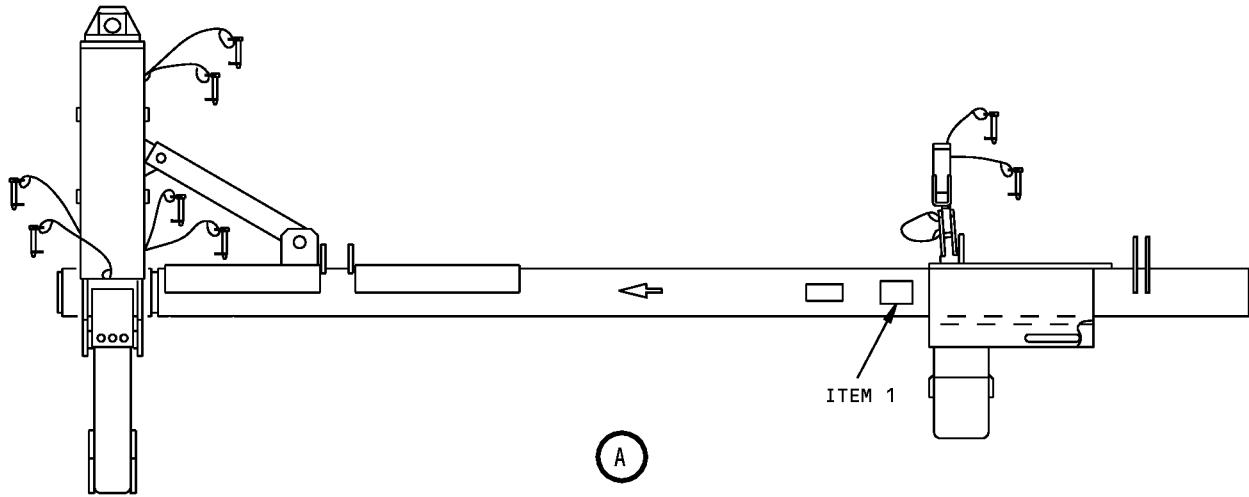

**RB211-524 G/H Engine Cradle**  
**Figure 1 (Sheet 2 of 3)**

ILLUSTRATED TOOL AND EQUIPMENT MANUAL

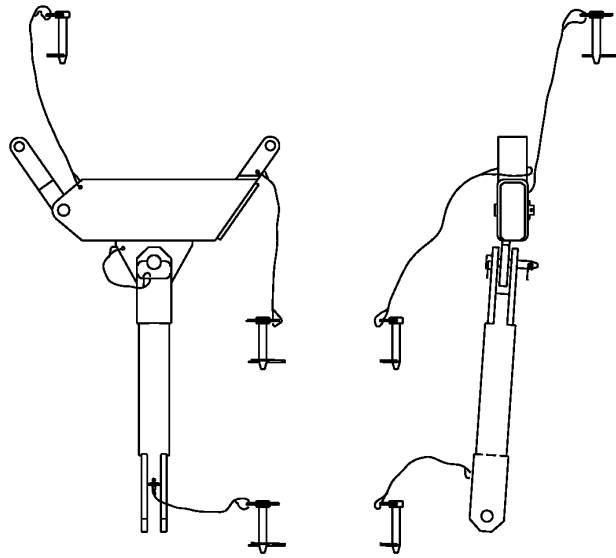

AFT SUPPORT ASSEMBLY



RB211-524 G/H Engine Cradle  
Figure 1 (Sheet 3 of 3)

REPAIRABLE/REPLACEABLE PARTS			
ITEM NO.	PART NO.	NOMENCLATURE	VENDOR CODE
1	F70308-15	PROOF LOAD TAG	

## ILLUSTRATED TOOL AND EQUIPMENT MANUAL

**PART NUMBER: A71048-1****NAME:** PROOF LOAD FIXTURE - BOOTSTRAP, RB211 ENGINE**AIRPLANE MAINTENANCE:** YES**COMPONENT MAINTENANCE:** NO

**USAGE & DESCRIPTION:** The A71048-1 proof load fixture is used to proof load the A71047 bootstrap equipment, used on 767 airplanes equipped with RB211-524H engines. Refer to the current A71047 and A71048 drawings for complete usage instructions. A71048-1 consists of an A71048-2 lower assembly, an A71048-3 upper assembly, an A71048-4 bracket assembly, an A71048-5 bracket assembly and various connecting hardware.

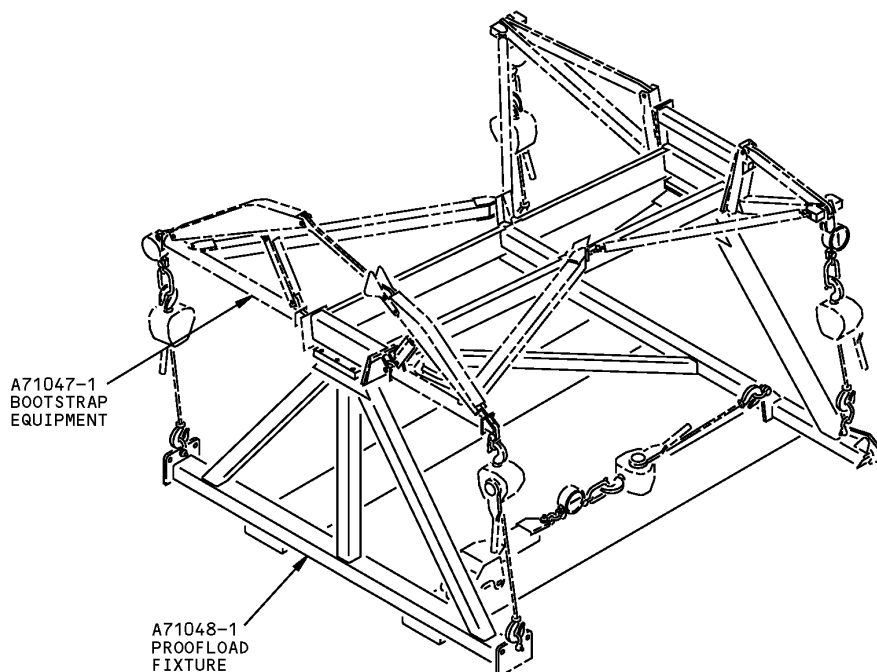
**WEIGHT:** 1700 lbs (771 kg)**DIMENSIONS:** 75 inches x 106 x 115 inches (1905 x 2692 x 2921 mm)

**RB211 Engine Bootstrap Proof Load Fixture  
Figure 1**



767

## ILLUSTRATED TOOL AND EQUIPMENT MANUAL

**PART NUMBER: A71047-150**

**NAME:** BOOTSTRAP EQUIPMENT - RB211-524H

**AIRPLANE MAINTENANCE:** YES

**COMPONENT MAINTENANCE:** NO

**USAGE & DESCRIPTION:** The A71047-150 bootstrap equipment is used on 767 airplanes equipped with RB211-524H engines. A71047-150 bootstrap equipment is used in conjunction with the G71015 cradle to remove and install the RB211-524H engines. The A71015 drawing allows for either A71015-152 and -153 manual lever action hoists or optional A4192-5MZ and A4195-5MZ pneumatically operated hoists. Refer to the current A71047 drawing for complete details regarding hoist options. Refer to AMM 71-00-02 for complete usage instructions. An A71048 proof-load fixture is required to proof-load the A71047-150 equipment. The A71015-150 bootstrap equipment is contained in a storage box and consists of:

A71015-150		
QUANTITY	NOMENCLATURE	PART NUMBER
3	DYNAMOMETER ASSEMBLY	A71047-4
1	FORWARD ARM ASSEMBLY - OUTBOARD	A71047-5
1	FORWARD ARM ASSEMBLY - INBOARD	A71047-143
1	DRAG BRACE ASSEMBLY - FORWARD OUTBOARD	A71047-7
1	DRAG BRACE ASSEMBLY - FORWARD INBOARD	A71047-8
1	DRAG BRACE ASSEMBLY - AFT OUTBOARD	A71047-9
1	DRAG BRACE ASSEMBLY - AFT INBOARD	A71047-10
1	AFT ARM ASSEMBLY - OUTBOARD	A71047-11
1	AFT ARM ASSEMBLY - INBOARD	A71047-12
1	FORWARD HOIST ASSEMBLY - RIGHT HAND	A71047-13
1	FORWARD HOIST ASSEMBLY - LEFT HAND	A71047-14
1	FORWARD STRUT ATTACH FITTING ASSEMBLY - LEFT HAND	A71047-15
1	FORWARD STRUT ATTACH FITTING ASSEMBLY - RIGHT HAND	A71047-16
1	MIDSTRUT FITTING ASSEMBLY - LEFT HAND	A71047-17
1	MIDSTRUT FITTING ASSEMBLY - RIGHT HAND	A71047-18
1	STRUT ATTACH FITTING ASSEMBLY - LEFT HAND	A71047-19
1	STRUT ATTACH FITTING ASSEMBLY - RIGHT HAND	A71047-20
1	THRU ROD ASSEMBLY	A71047-21
2	AFT HOIST ADAPTER ASSEMBLY	A71047-22



767

**ILLUSTRATED TOOL AND EQUIPMENT MANUAL**

<b>A71015-150</b>		
<b>QUANTITY</b>	<b>NOMENCLATURE</b>	<b>PART NUMBER</b>
2	AFT CHAIN HOIST, LEVER OPERATED	A71047-152
2	FORWARD CHAIN HOIST, AIR OPERATED	A71047-153
2	AFT CHAIN HOIST, AIR OPERATED (OPTION FOR A71047-152)	A4192-5MZ
2	FORWARD CHAIN HOIST, AIR OPERATED (OPTION FOR A71047-153)	A4195-5MZ
1	STORAGE BOX	

**WEIGHT:** 400 lbs (181 kg)

**DIMENSIONS:** 32 x 38 x 80 inches (813 x 965 x 2032 mm)

**NOTE:** A71047-150 supersedes A71047-142.

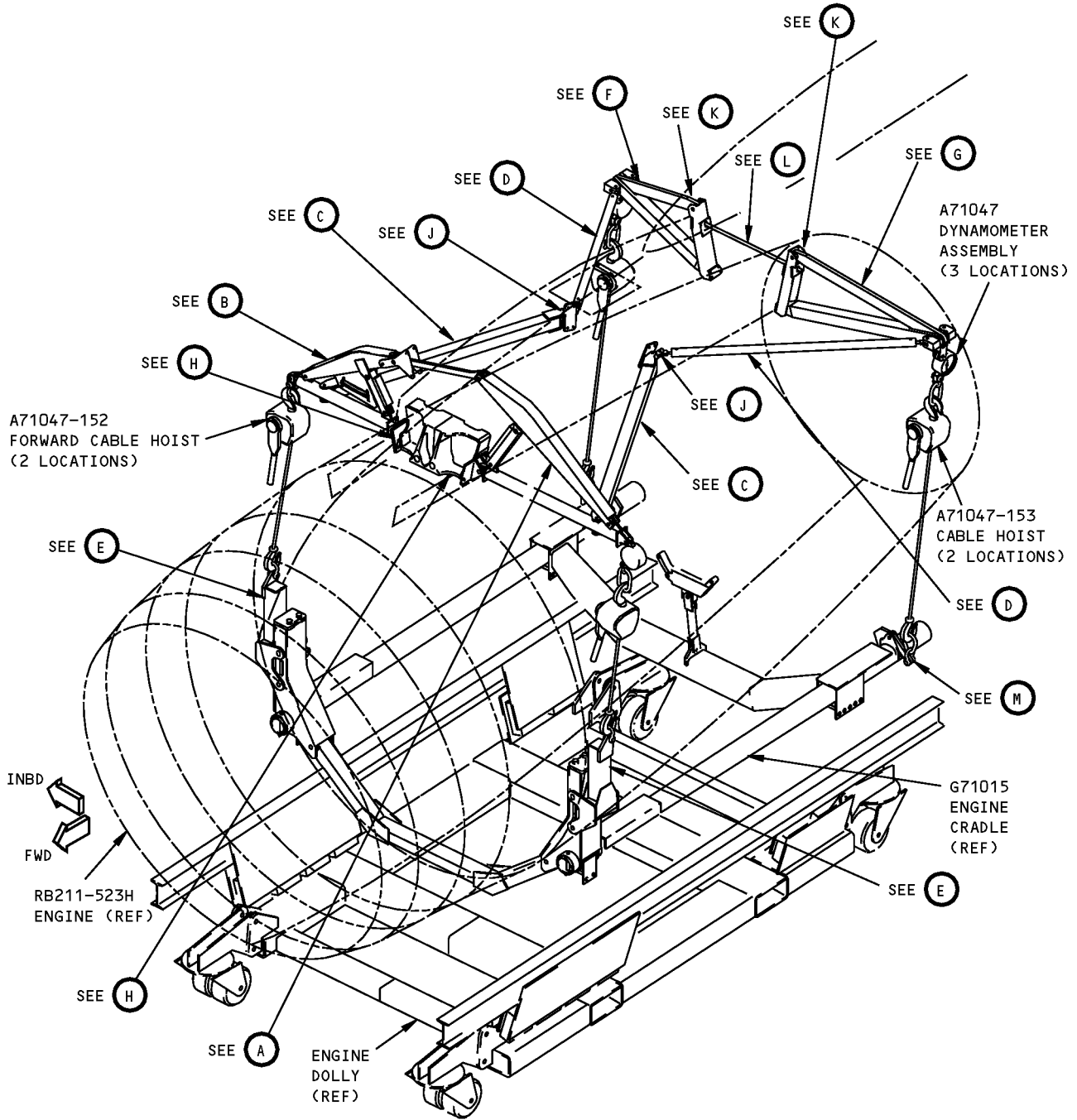

**RB211-524H Bootstrap Equipment**  
**Figure 1 (Sheet 1 of 9)**

**ILLUSTRATED TOOL AND EQUIPMENT MANUAL**

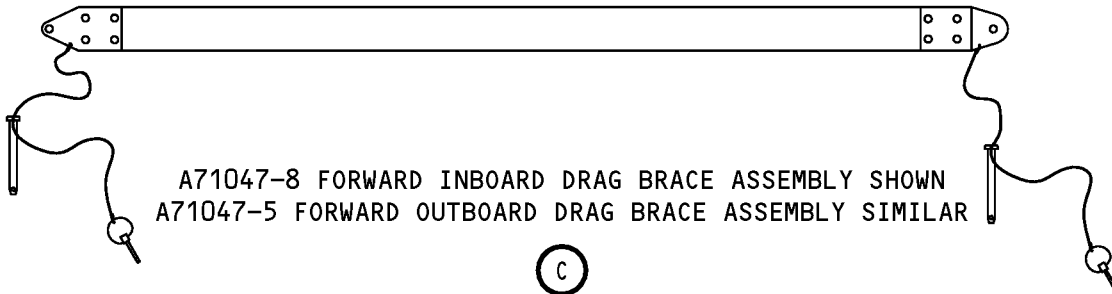
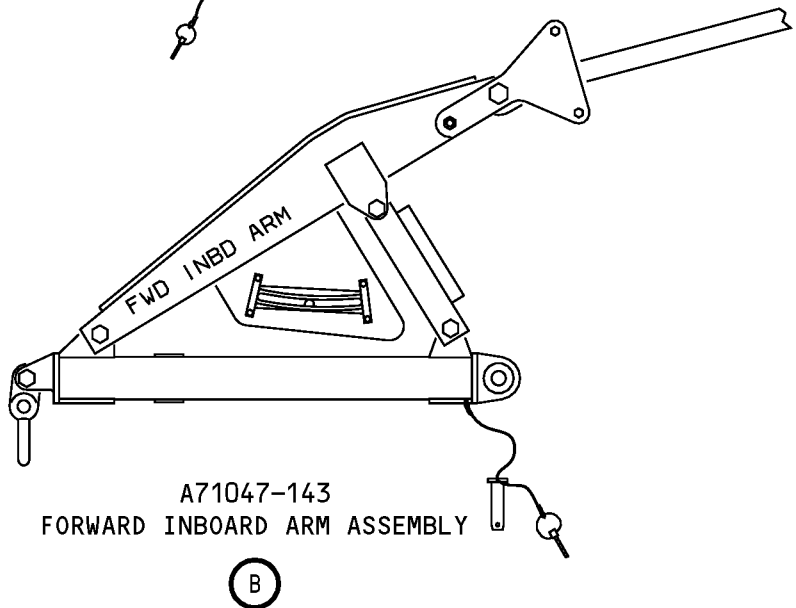
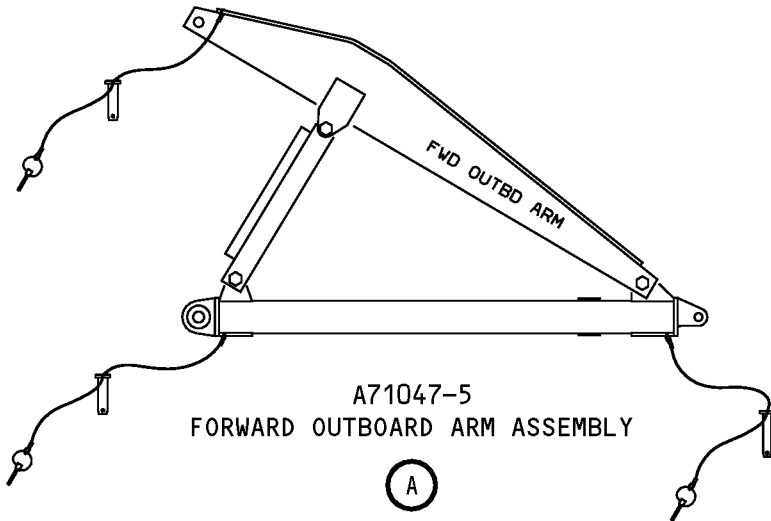

**RB211-524H Bootstrap Equipment  
Figure 1 (Sheet 2 of 9)**

**ILLUSTRATED TOOL AND EQUIPMENT MANUAL**

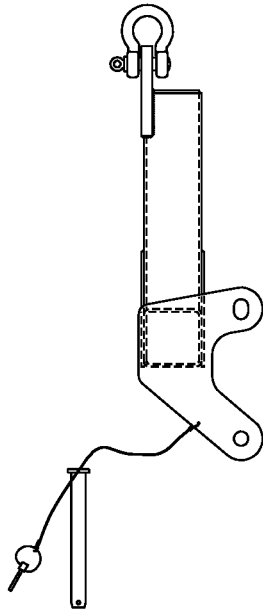
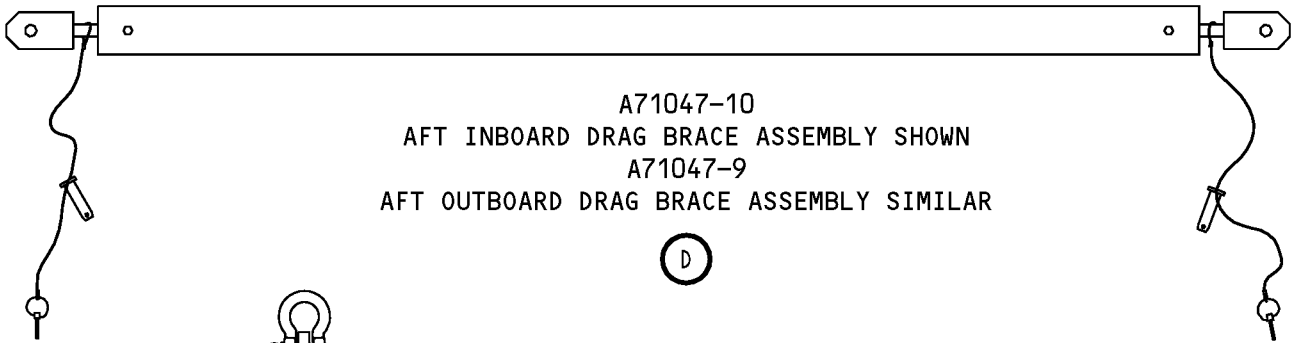

A71047-13  
RIGHT HAND FORWARD HOIST ASSEMBLY SHOWN  
A71047-14  
LEFT HAND FORWARD HOIST ASSEMBLY SIMILAR

(E)

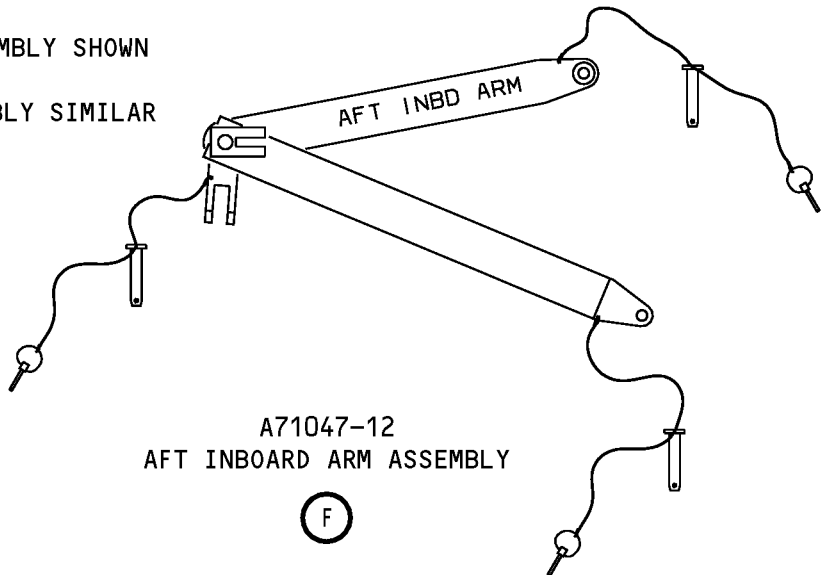

A71047-12  
AFT INBOARD ARM ASSEMBLY

**RB211-524H Bootstrap Equipment  
Figure 1 (Sheet 3 of 9)**



**767**  
**ILLUSTRATED TOOL AND EQUIPMENT MANUAL**

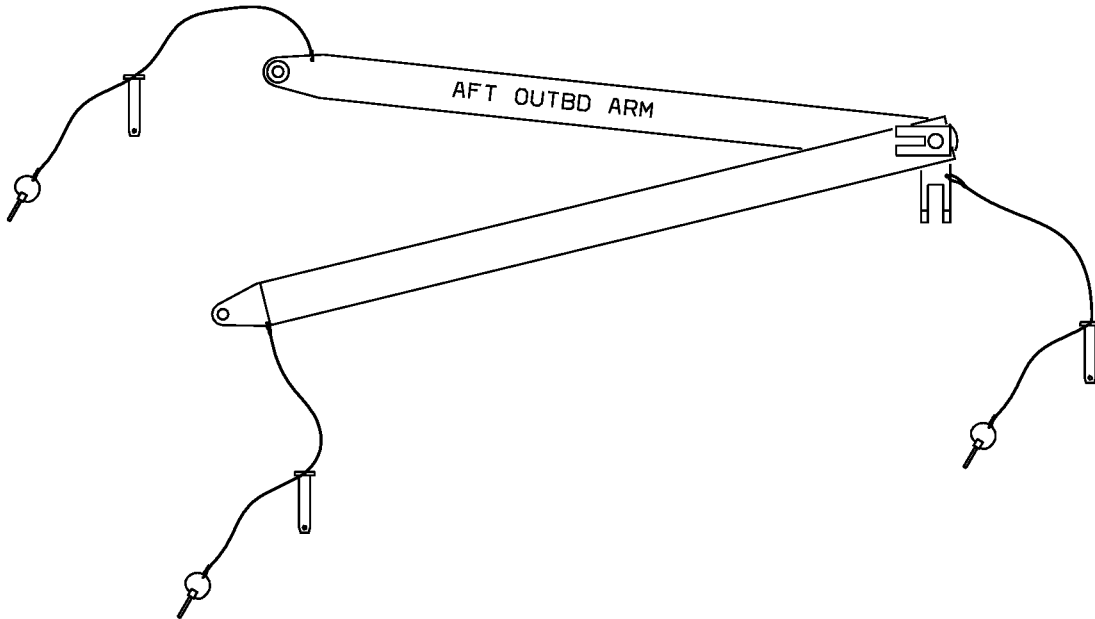

A71047-11  
AFT OUTBOARD ARM ASSEMBLY

ⓐ

**RB211-524H Bootstrap Equipment**  
**Figure 1 (Sheet 4 of 9)**

**ILLUSTRATED TOOL AND EQUIPMENT MANUAL**

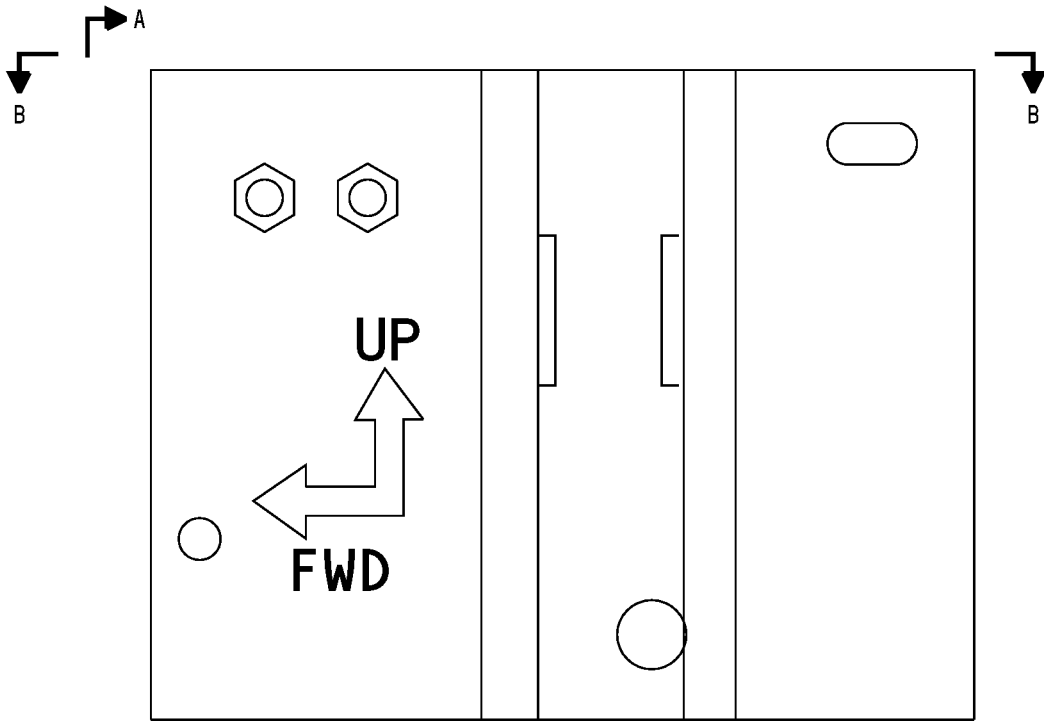

A71047-15  
LEFT HAND FORWARD STRUT ATTACHMENT FITTING SHOWN  
A71047-16  
RIGHT HAND FORWARD STRUT ATTACHMENT FITTING OPPOSITE

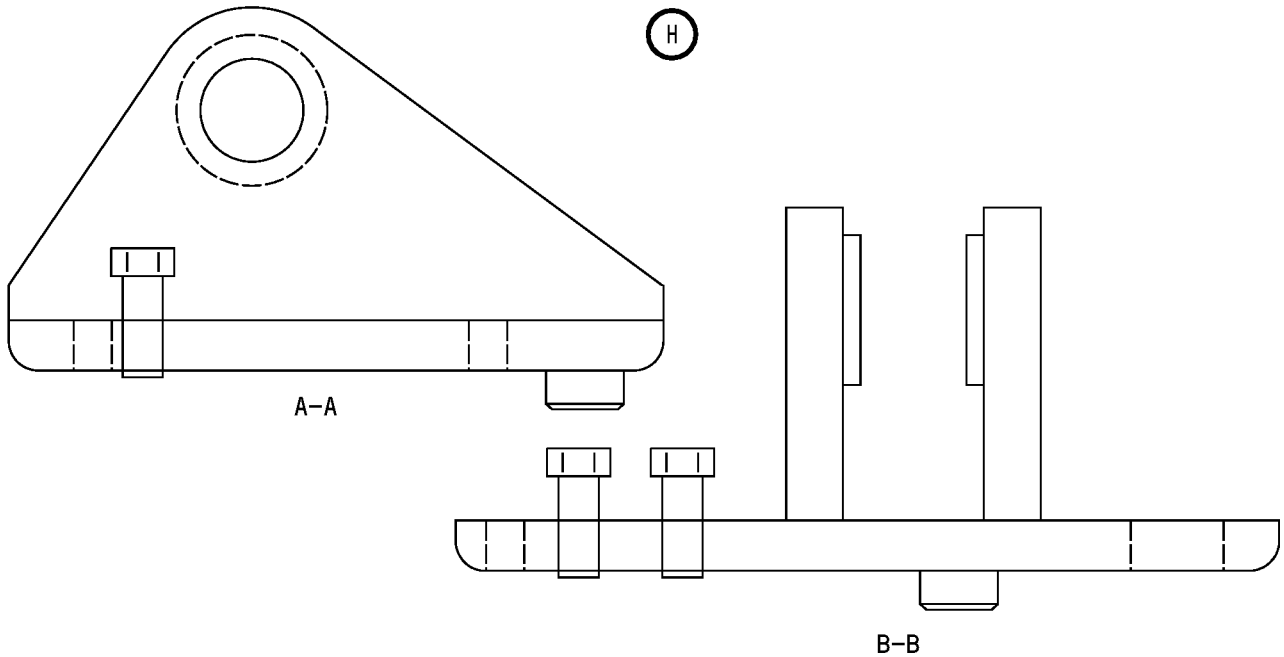

**RB211-524H Bootstrap Equipment**  
**Figure 1 (Sheet 5 of 9)**

**767  
ILLUSTRATED TOOL AND EQUIPMENT MANUAL**

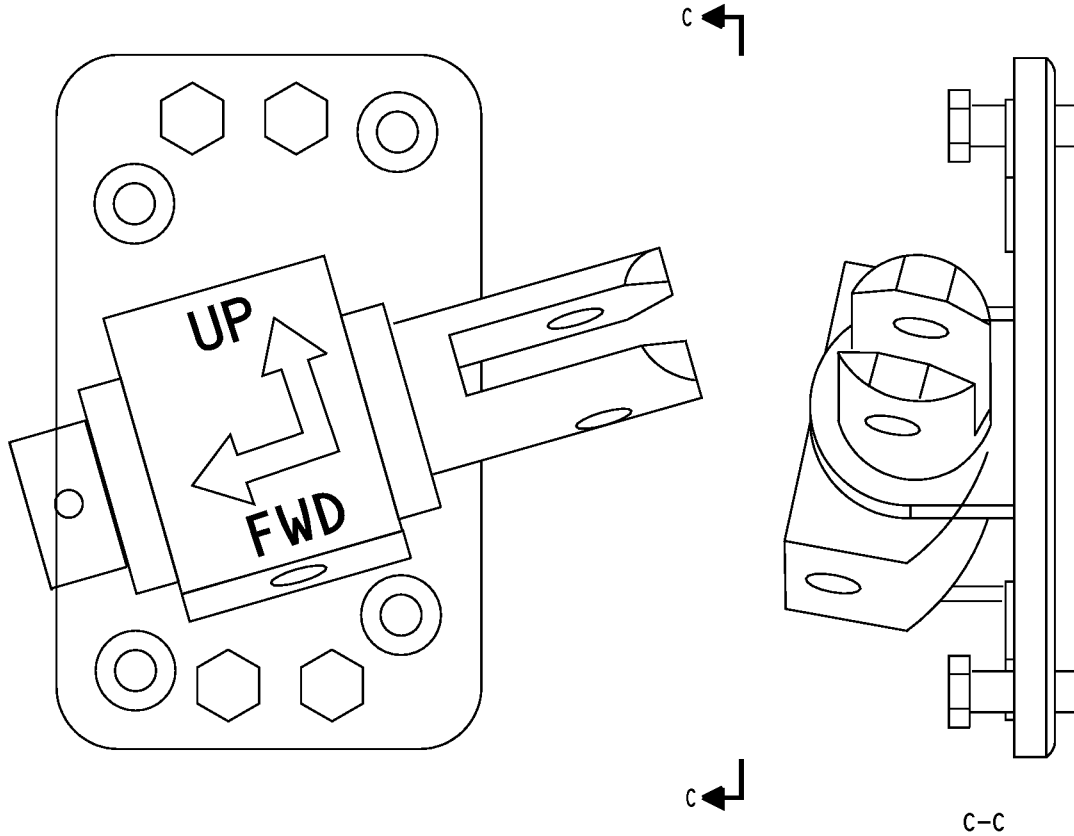

A71047-17  
LEFT HAND MIDSTRUT FITTING ASSEMBLY SHOWN  
A71047-18  
RIGHT HAND MIDSTRUT FITTING ASSEMBLY OPPOSITE

ⓐ

**RB211-524H Bootstrap Equipment  
Figure 1 (Sheet 6 of 9)**

**ILLUSTRATED TOOL AND EQUIPMENT MANUAL**

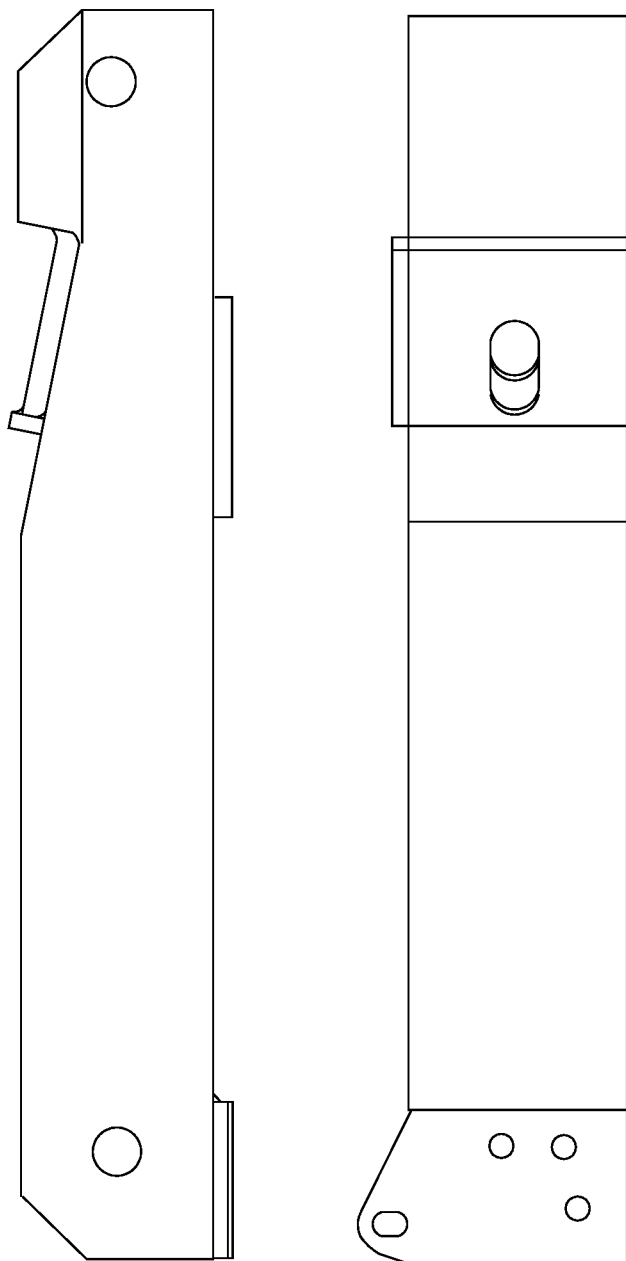

A71047-19  
LEFT HAND STRUT ATTACHMENT ASSEMBLY SHOWN  
A71047-20  
RIGHT HAND STRUT ATTACHMENT ASSEMBLY OPPOSITE

(K)

**RB211-524H Bootstrap Equipment**  
**Figure 1 (Sheet 7 of 9)**

**767**  
**ILLUSTRATED TOOL AND EQUIPMENT MANUAL**

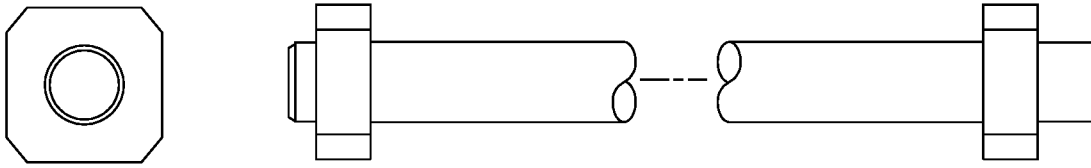

A71047-21  
THRU ROD ASSEMBLY



**RB211-524H Bootstrap Equipment**  
**Figure 1 (Sheet 8 of 9)**

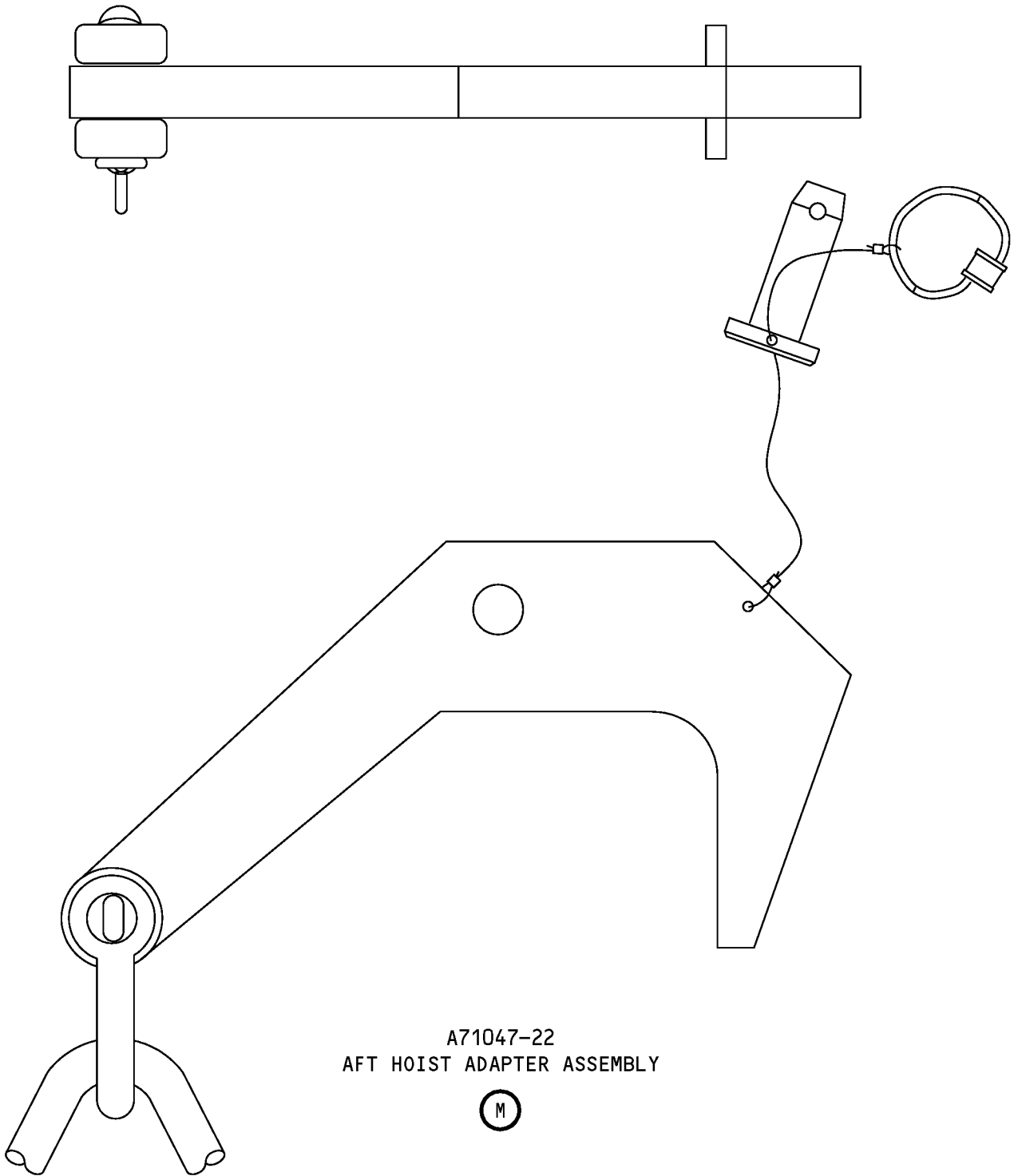

**RB211-524H Bootstrap Equipment  
Figure 1 (Sheet 9 of 9)**

## ILLUSTRATED TOOL AND EQUIPMENT MANUAL

**PART NUMBER: A71046-1****NAME:** LOCATING JIG - ENGINE BUILDUP (EBU) TO STRUT, SYSTEM PW4000**AIRPLANE MAINTENANCE:** YES**COMPONENT MAINTENANCE:** NO

**USAGE & DESCRIPTION:** The A71046-1 locating jig is used on 767 airplanes equipped with PW4000 engines. A71046 is used to align pneumatic tube and electrical connectors on engine buildup for correct mating to struts. Refer to the PW4000 Powerplant Buildup Manual 71-00-00 for complete usage instructions. A71046-1 consists of an A71046-2 locating jig assembly, an A71046-23 set-up rod assembly, both contained in a storage box.

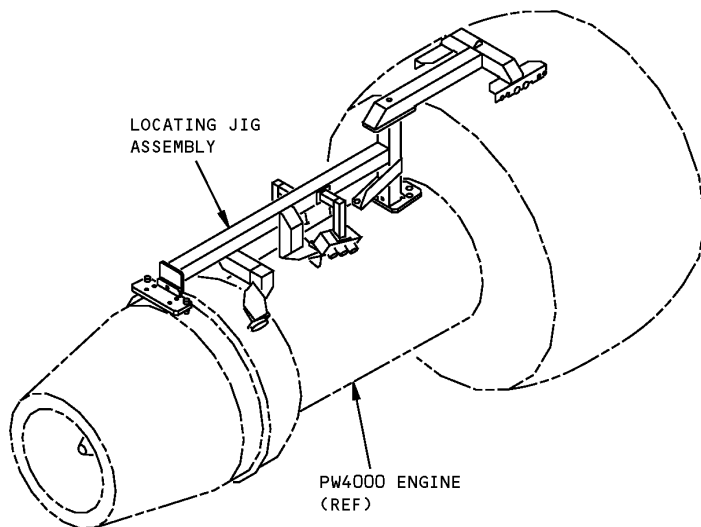
**WEIGHT:** 120 lbs (54 kg)**DIMENSIONS:** 31 x 35 x 90 inches (787 x 889 x 2286 mm)

**PW4000 Engine Buildup to Strut Locating Jig  
Figure 1**



767

## ILLUSTRATED TOOL AND EQUIPMENT MANUAL

**PART NUMBER: B71044-10, -28**

**NAME:** ADAPTER EQUIPMENT - LOAD TEST, PRESSURE RELIEF DOOR LATCH

**AIRPLANE MAINTENANCE:** YES

**COMPONENT MAINTENANCE:** NO

**USAGE & DESCRIPTION:** The B71044-10 or -28 adapter equipment is used on all 767 airplanes. B71044 is used to apply a test load, with the use of a torque wrench, on the pressure relief door latch. The B71044-10 equipment is used on pressure relief doors that have removable fasteners. The B71044-28 equipment expands the usage to pressure relief doors that have removable or permanent fasteners. Refer to AMM 71-11-03, AMM 71-11-08 and AMM 54-53-01 for complete usage instructions.

B71044-10		
QUANTITY	NOMENCLATURE	PART NUMBER
1	ADAPTER ASSEMBLY	B71044-27
1	PIVOT SUPPORT ASSEMBLY	B71044-11
1	STORAGE BOX	

B71044-28		
QUANTITY	NOMENCLATURE	PART NUMBER
1	ADAPTER ASSEMBLY	B71044-27
1	PIVOT SUPPORT ASSEMBLY	B71044-11
1	TORQUE ADAPTER	B71044-30
1	STORAGE BOX	

**WEIGHT:** 2 lbs (0.9 kg)

**DIMENSIONS:** 3 x 6 x 11 inches (76 x 152 x 279 mm)

**NOTE:** B71044-28 replaces B71044-10 for future procurement.



**ILLUSTRATED TOOL AND EQUIPMENT MANUAL**

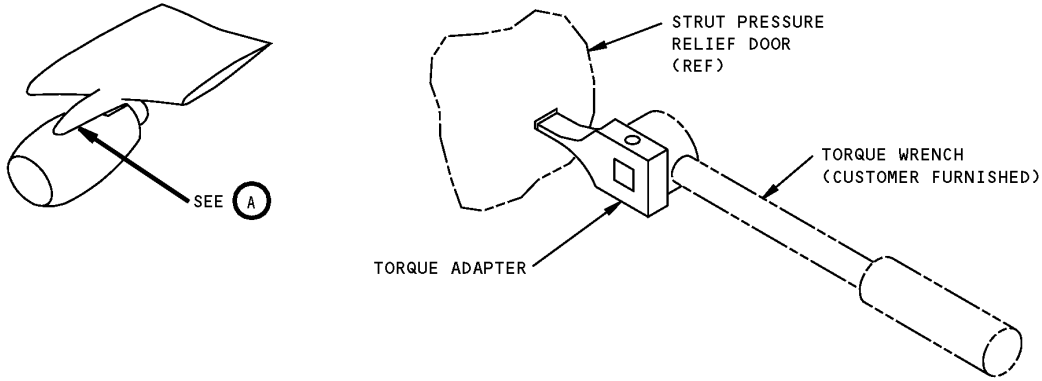

TEST FOR PERMANENT FASTENERS SHOWN

(A)

**Pressure Relief Door Latch Load Test Adapter Equipment  
Figure 1 (Sheet 1 of 2)**

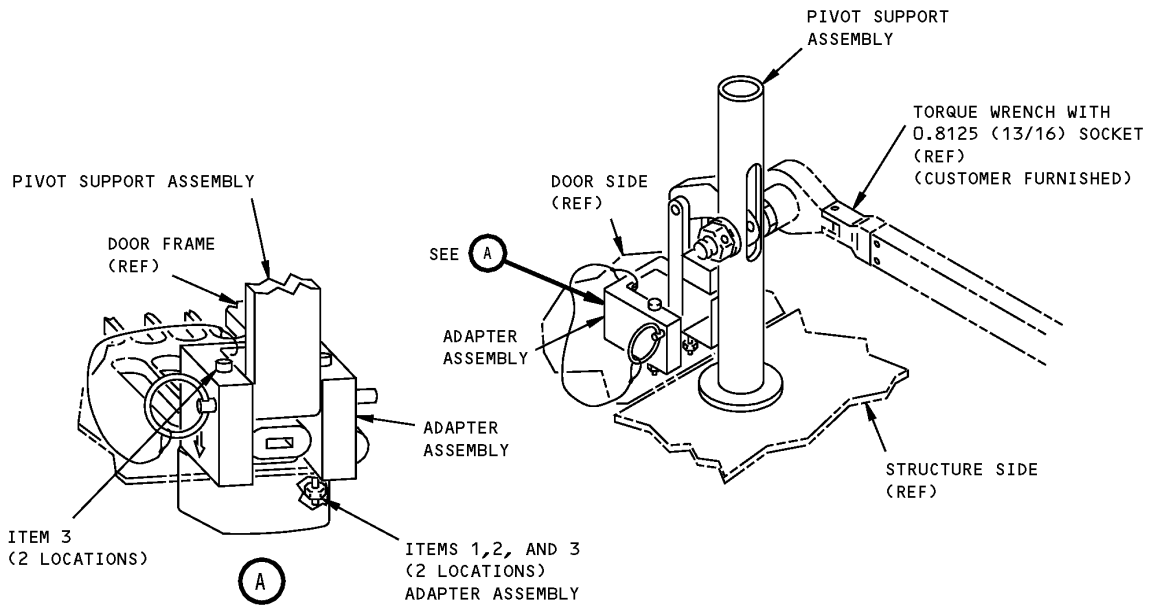

TEST FOR REMOVABLE FASTENERS SHOWN

**Pressure Relief Door Latch Load Test Adapter Equipment  
Figure 1 (Sheet 2 of 2)**



767

**ILLUSTRATED TOOL AND EQUIPMENT MANUAL**

<b>REPAIRABLE/REPLACEABLE PARTS</b>			
<b>ITEM NO.</b>	<b>PART NO.</b>	<b>NOMENCLATURE</b>	<b>VENDOR CODE</b>
1	B71044-5	HEX JAM NUT	
2	B71044-6	PLAIN WASHER	
3	B71044-7	HEX SOCKET HEAD CAP SCREW	



767

## ILLUSTRATED TOOL AND EQUIPMENT MANUAL

**PART NUMBER: A71054-1**

**NAME:** TORQUE EQUIPMENT - ENGINE MOUNT BOLTS, RB211-524G/H

**AIRPLANE MAINTENANCE:** YES

**COMPONENT MAINTENANCE:** NO

**USAGE & DESCRIPTION:** The A71054-1 torque equipment is used on 767 airplanes equipped with RB211-524G/H engines. A71054 is used to torque the mounting bolts of the RB211-524G/H engine. Refer to the current A71054 drawing for complete usage instructions. A71054-1 consists of:

A71054-1		
QUANTITY	NOMENCLATURE	PART NUMBER
1	RATCHET HEAD ASSEMBLY	A71054-2
1	EXTENSION ASSEMBLY	A71054-3
1	LONG SOCKET	A71054-7
1	SOCKET	GLDH342
1	STORAGE BOX	

**WEIGHT:** 13 lbs (6 kg)

**DIMENSIONS:** 2.0 x 6.0 x 36.0 inches (51 X 152 X 914 mm)

**767**  
**ILLUSTRATED TOOL AND EQUIPMENT MANUAL**

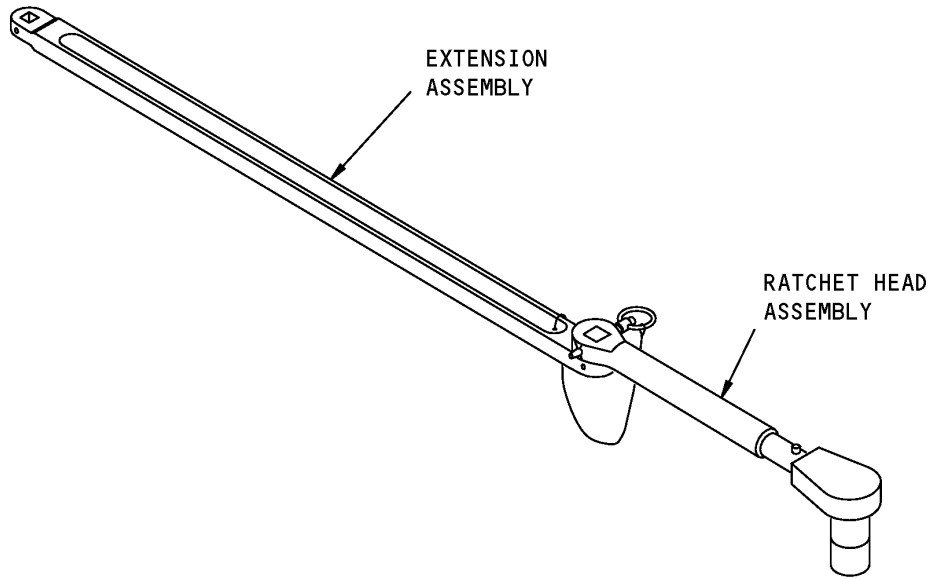

**RB211-524-G/H Engine Mount Bolts Torque Equipment**  
**Figure 1**



767

## ILLUSTRATED TOOL AND EQUIPMENT MANUAL

**PART NUMBER: 3MIT65B89603**

**NAME:** TOOL SET, RB211 ENGINE MOUNT BOLT

**AIRPLANE MAINTENANCE:** YES

**COMPONENT MAINTENANCE:** NO

**USAGE & DESCRIPTION:** The 3MIT65B89603 tool set is used on 767 airplanes equipped with RB211-524G/H engines. The 3MIT65B89603 tool set is used to remove or install the engine mount fasteners during removal or installation of the engine from the airplane. The tool set consists of 11 parts comprising special adapters, ratchet heads, sockets, and extensions. All the tools within the set should be arranged in various lever combinations which provide for the removal and installation of the forward and aft engine mount fasteners during engine removal or installation.

**ILLUSTRATED TOOL AND EQUIPMENT MANUAL**

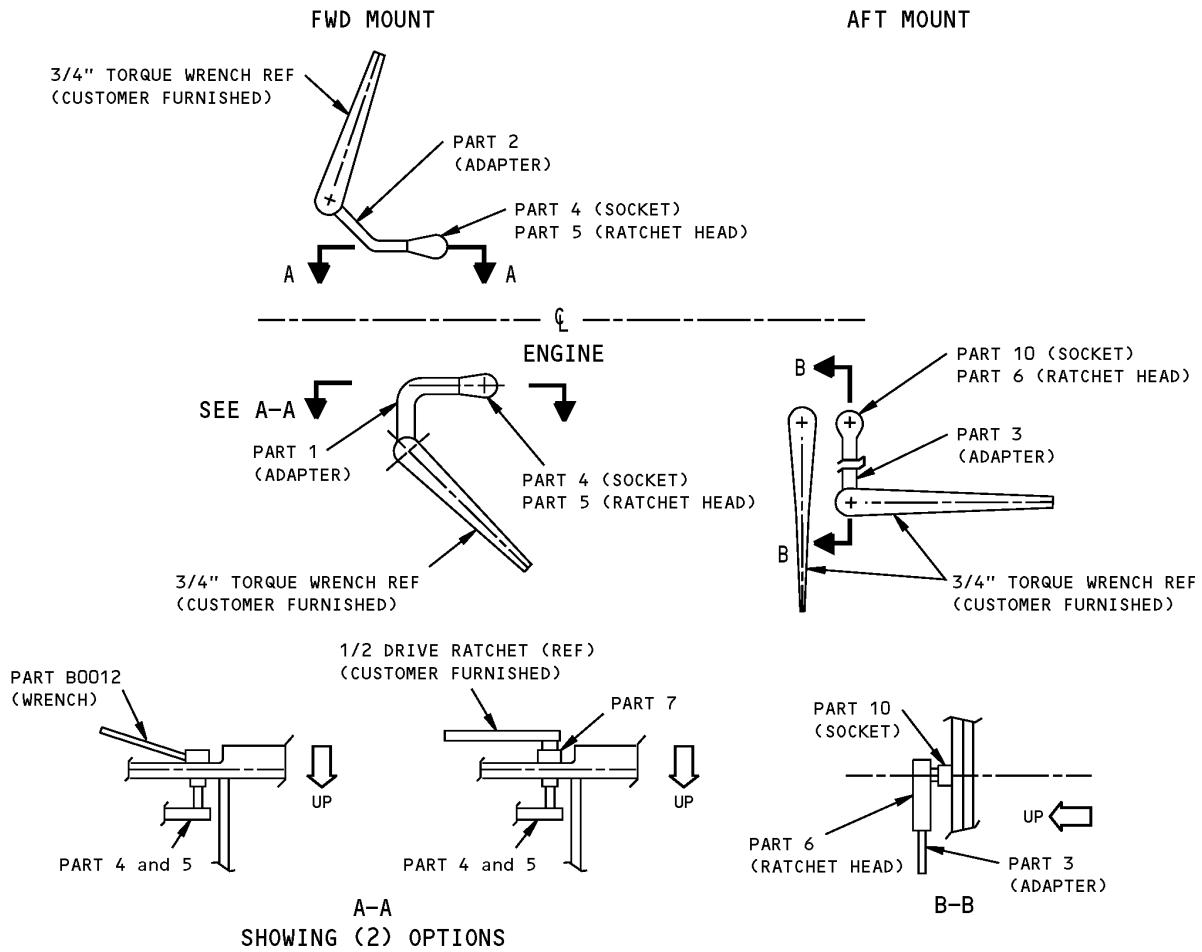

**RB211 Engine Mount Bolt Tool Set  
Figure 1**



767

## ILLUSTRATED TOOL AND EQUIPMENT MANUAL

**PART NUMBER: J71006**

**NAME:** SPECIFICATION - POWERED HOIST SYSTEM, GROUND SUPPORT EQUIPMENT (GSE) OPERATIONS

**AIRPLANE MAINTENANCE:** YES

**COMPONENT MAINTENANCE:** NO

**USAGE & DESCRIPTION:** The J71006 powered hoist system may be used on all 767 airplanes. J71006 is a specification drawing providing information for the design, purchase, fabrication and use of an air-powered hoisting system with a load readout capability. The powered hoisting system is an alternate to the manual lever hoists provided with engine bootstrap systems. The system will provide safer working conditions by eliminating the requirement for personnel to operate manual hoists while on ladders or stands. One operator will control all hoists and can observe the loads applied to the airplane component. The system will provide a preset overload protection for the hoisting system and for the specific airplane model and engine type. Equipment and usage instructions conforming to this specification were developed by a joint agreement between the Boeing Company and Morgan Aero Products of Everett, Washington. A prototype was developed, tested and used to remove and install airplane components. The J71006 drawing also presents interface information necessary to allow Boeing designed ground support equipment to be used with the powered hoist system.

The following system description is only a general observation of the basic functions of the J71006 system. It ignores many safety features and exact operating points that are too complex for description in this document.

The J71006 powered hoist system is controlled electrically and manually. The control cabinet is transportable by one person. It contains control components, batteries and battery charging systems, connecting hardware, pneumatic controls and plumbing and redundant manual control of valves.

Four, 4-chain hoists are pneumatically operated and electrically controlled with a manual backup. Nominal pneumatic pressure required to move the hoists is 90 psi. The hoists are required to have a working load of no less than 12,000 pounds each. The hoists shall have a minimum 10 feet of lift. The hoist's air motor drive shall provide a lift speed of 4 inches per minute. A load cell is provided with each hoist. Load cell readouts are given on the control pendant with a toggle allowing for "tare" and "total" weight displayed.

The control pendant displays the load cell readout. The control pendant also allows for control of each hoist separately or with both forward and/or both aft hoists at the same time. The control pendant allows for 50 feet of travel from the control cabinet. The hoist control on the pendant allows for setting and automatic sensing of predetermined loads and will limit loads with an automatic shutoff.

**767**  
**ILLUSTRATED TOOL AND EQUIPMENT MANUAL**

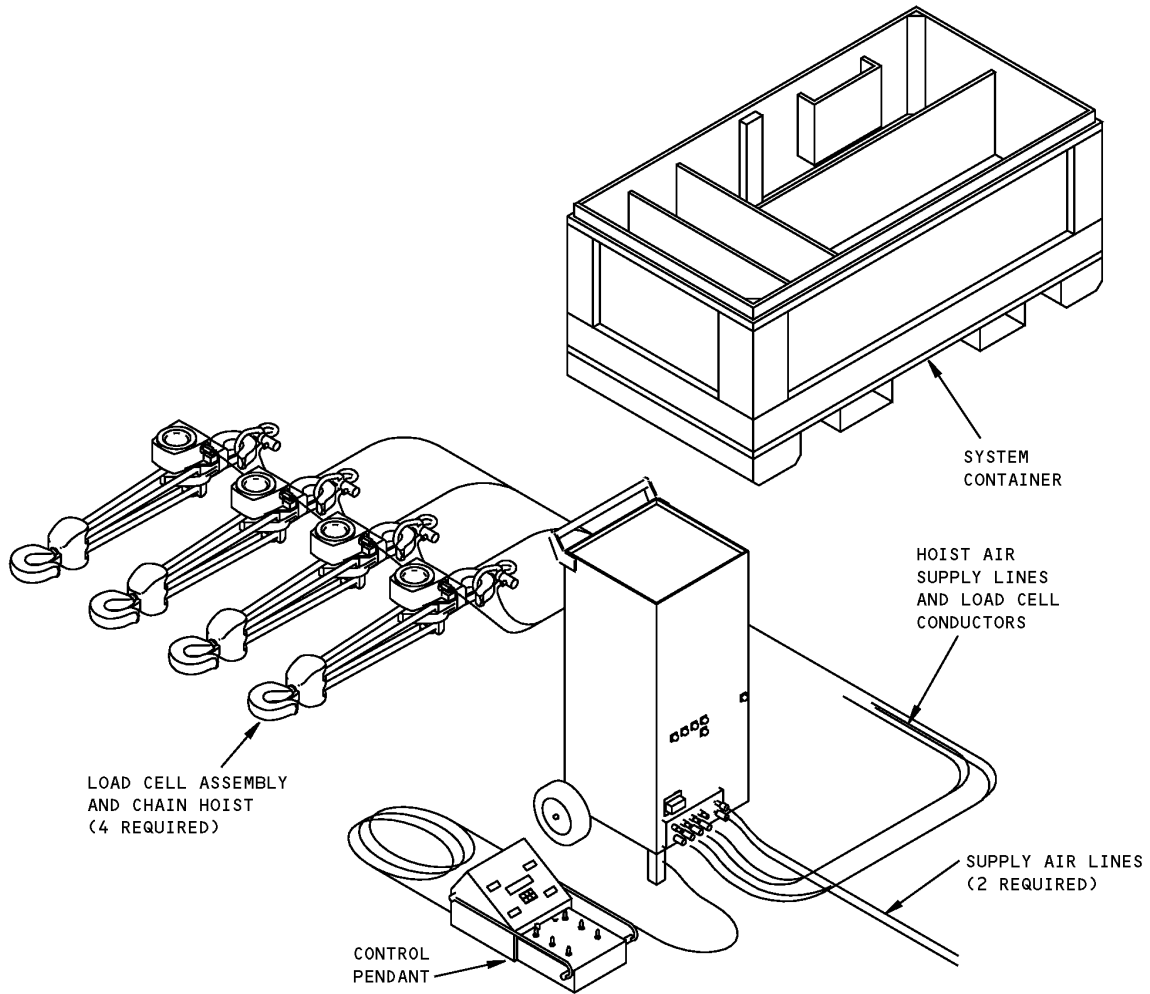

**GSE Operations Powered Hoist System Specification**  
**Figure 1**





767

## ILLUSTRATED TOOL AND EQUIPMENT MANUAL

**PART NUMBER: G71022-44**

**NAME:** HOLD OPEN EQUIPMENT - ENGINE FAN/CORE COWL, CF6-80C2B

**AIRPLANE MAINTENANCE:** YES

**COMPONENT MAINTENANCE:** NO

**USAGE & DESCRIPTION:** G71022-44 is used on 767 airplanes that are equipped with CF6-80C2B engines. G71022-44 is used to hold the fan and core cowls open and is used in conjunction with the G78002 thrust reverser cowl hold open set. G71022-44 is not to be used when the wind velocity exceeds 20 knots. Refer to AMM 71-00-02 for complete usage information. G71022-44 consists of a G71022-2 and -3 right and left core cowl attachment assemblies, G71022-45 and -46 left hand and right hand thrust reverser attachment assemblies and two G71022-6 fan cowl attachment assemblies, all contained in a storage box.

**WEIGHT:** 100 lbs (45 kg)

**DIMENSIONS:** 10 x 20 x 30 inches (254 x 508 x 762 mm)

**NOTE:** G71022-44 supersedes G71022-1.

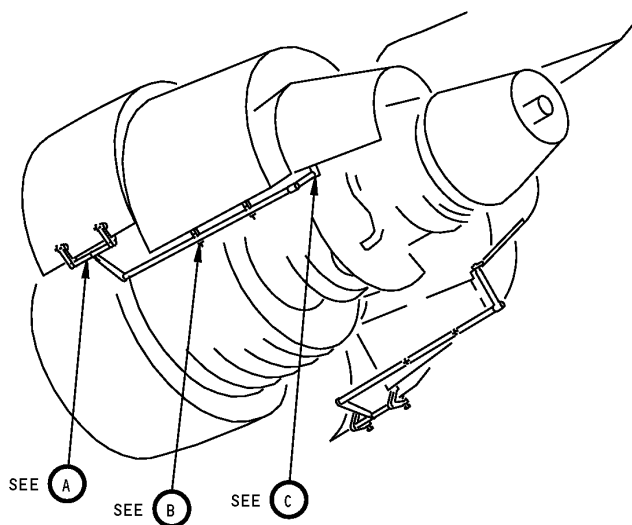

**CF6-80C2B Engine Fan/Core Cowl Hold Open Equipment  
Figure 1 (Sheet 1 of 2)**

**767**  
**ILLUSTRATED TOOL AND EQUIPMENT MANUAL**

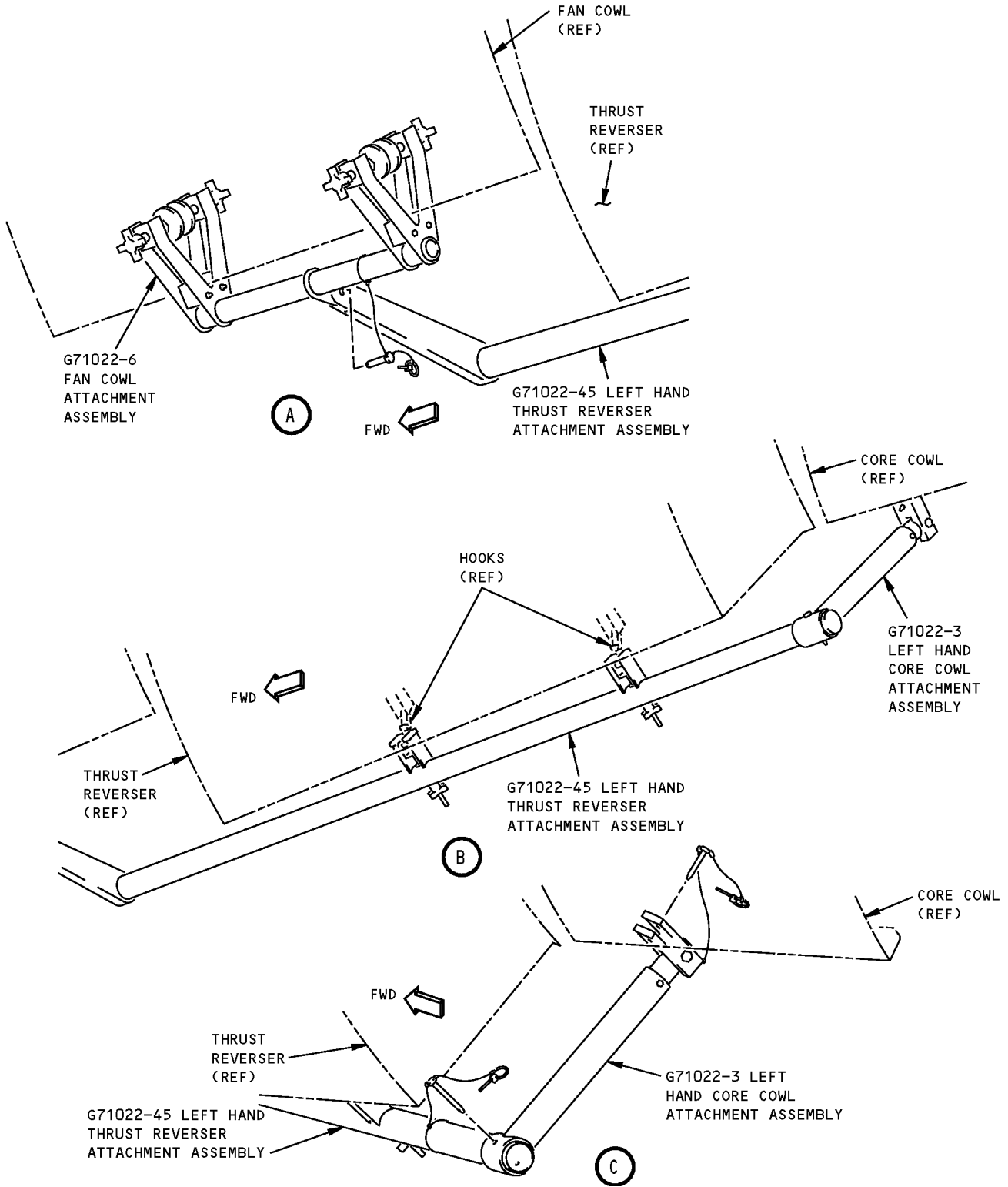

**CF6-80C2B Engine Fan/Core Cowl Hold Open Equipment**  
**Figure 1 (Sheet 2 of 2)**



767

## ILLUSTRATED TOOL AND EQUIPMENT MANUAL

**PART NUMBER: A71016-1, -23**

**NAME:** SLING EQUIPMENT - CORE COWL

**AIRPLANE MAINTENANCE:** YES

**COMPONENT MAINTENANCE:** NO

**USAGE & DESCRIPTION:** The A71016-1 sling equipment is used on 767 airplanes with JT9D-7R4D and PW4000 standard nacelle engines. A71016-23 sling equipment is used on 767 airplanes with JT9D-7R4D load sharing nacelle engines. A71016 is a sling used in conjunction with an A20001 hoist to lift and position the core cowl during engine maintenance operations. Refer to AMM 71-11-06 for complete usage instructions. A71016-1 consists of an A71016-3 left hand sling assembly and an A71016-4 right hand sling assembly, both contained in a storage box. A71016-23 consists of an A71016-19 left hand sling assembly and an A71016-20 right hand sling assembly, both contained in a storage box.

**WEIGHT:** 26 lbs (12 kg)

**DIMENSIONS:** 3 x 11 x 31 inches (76 x 279 x 787 mm)

**ILLUSTRATED TOOL AND EQUIPMENT MANUAL**

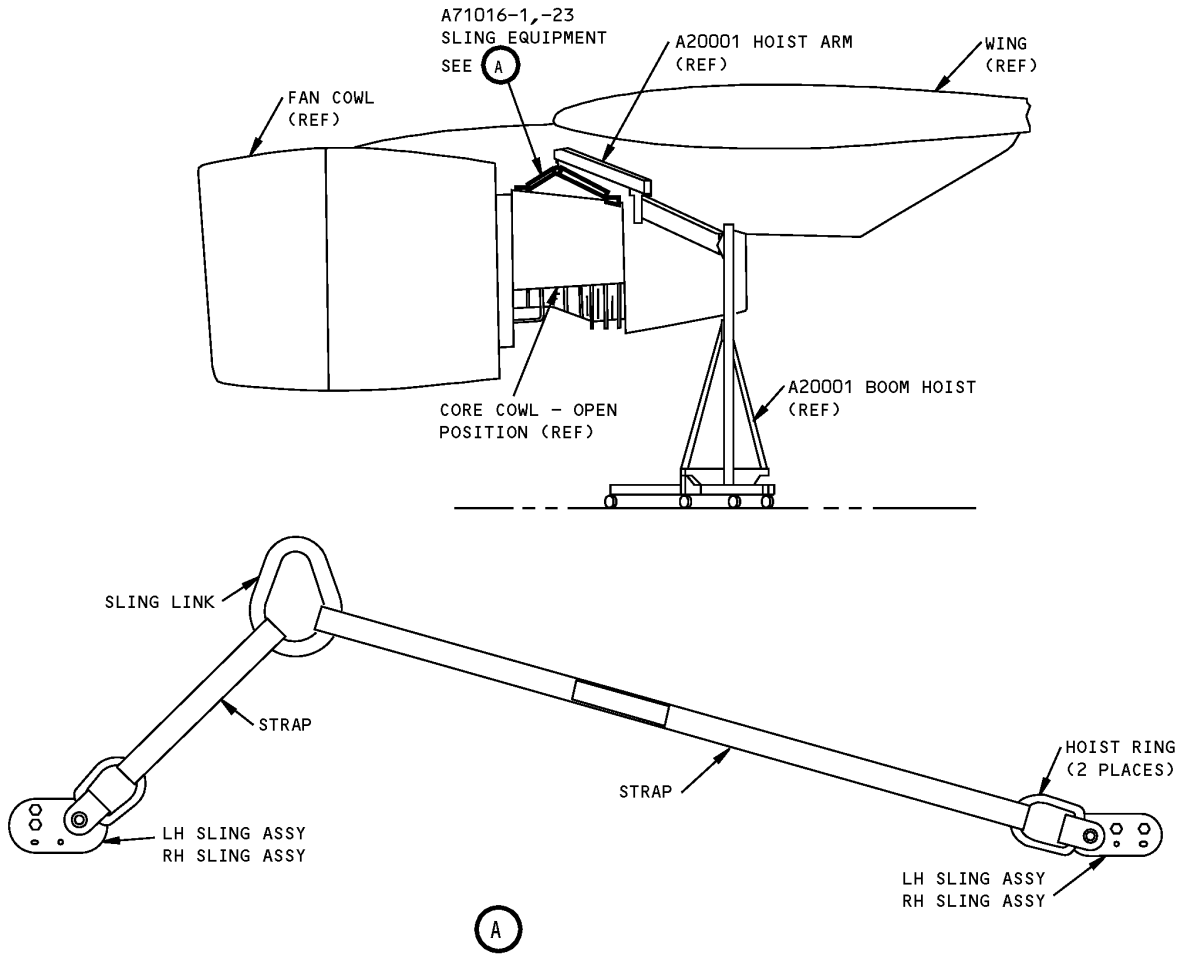

**JT9D-7R4D AND PW4000 Core Cowl Sling Equipment  
Figure 1**

**ILLUSTRATED TOOL AND EQUIPMENT MANUAL**

**PART NUMBER: A71026-1**

**NAME:** HOLD OPEN EQUIPMENT - 40-KNOT, CF6-80A FAN COWL

**AIRPLANE MAINTENANCE:** YES

**COMPONENT MAINTENANCE:** NO

**USAGE & DESCRIPTION:** The A71026-1 hold open equipment is used on 767-200 and -200ER airplanes equipped with CF6-80A engines. A71026-1 consists of left, right, and center components that are used to hold the CF6-80A engine fan cowls open during engine change operations. A71026 is designed for 40-knot ground wind loads. Refer to the current A71026 drawing for complete usage instructions. A71026-1 consists of an A71026-2 center hold open assembly, A71026-3 left hand end hold open assembly and an A71026-4 right hand end hold open assembly, all contained in a storage box.

**WEIGHT:** 98 lbs (44 kg)

**DIMENSIONS:** 20 x 30 175 inches (508 x 762 x 4445 mm)

**NOTE:** A71026 and A71033 replaces A71018 for future procurement.

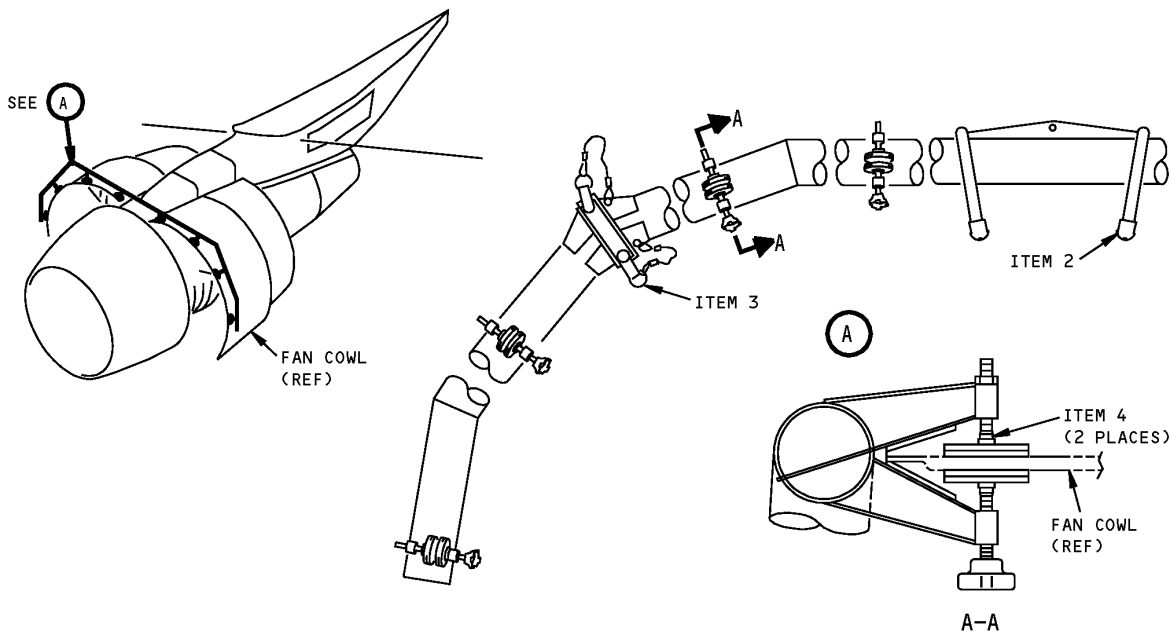

**40 Knot, CF6-80A Fan Cowl Hold Open Equipment  
Figure 1**



767

ILLUSTRATED TOOL AND EQUIPMENT MANUAL

REPAIRABLE/REPLACEABLE PARTS			
ITEM NO.	PART NO.	NOMENCLATURE	VENDOR CODE
1	F70308-15	PROOF LOAD TAG	
2	64-20	RUBBER CAP	V70485
3	NAS1339C2C54D	QUICK RELEASE PIN	
4	A71026-35	CLAMP KNOB ASSEMBLY	



767

## ILLUSTRATED TOOL AND EQUIPMENT MANUAL

**PART NUMBER: A71033-31**

**NAME:** HOLD OPEN EQUIPMENT - 40-KNOT, CF6-80A CORE COWL

**AIRPLANE MAINTENANCE:** YES

**COMPONENT MAINTENANCE:** NO

**USAGE & DESCRIPTION:** The A71033-31 hold open equipment is used on all 767 airplanes equipped with CF6-80A engines. A71033 consists of left-hand and right-hand components that are used to hold the CF6-80A engine core cowls open during engine change operations. A71033 is designed for 40-knot ground wind loads. Refer to AMM 71-00-02 and current A71033 drawing for additional usage instructions. The A71033-31 consists of the following:

A71033-31		
QUANTITY	NOMENCLATURE	PART NUMBER
1	FORWARD LEFT HAND HOLD OPEN ASSEMBLY	A71033-20
1	FORWARD RIGHT HAND HOLD OPEN ASSEMBLY	A71033-21
1	AFT LEFT HAND HOLD OPEN ASSEMBLY	A71033-29
1	AFT RIGHT HAND HOLD OPEN ASSEMBLY	A71033-30
1	STORAGE BOX	

**WEIGHT:** 26 lbs (12 kg)

**DIMENSIONS:** 3.5 x 5 x 48 inches (89 x 127 x 1219 mm)

**NOTE:** A71033 and A71026 replace A71018.  
A71033-19 replaces A71033-1 for future procurement.  
A71033-31 supersedes A71033-19.

**ILLUSTRATED TOOL AND EQUIPMENT MANUAL**

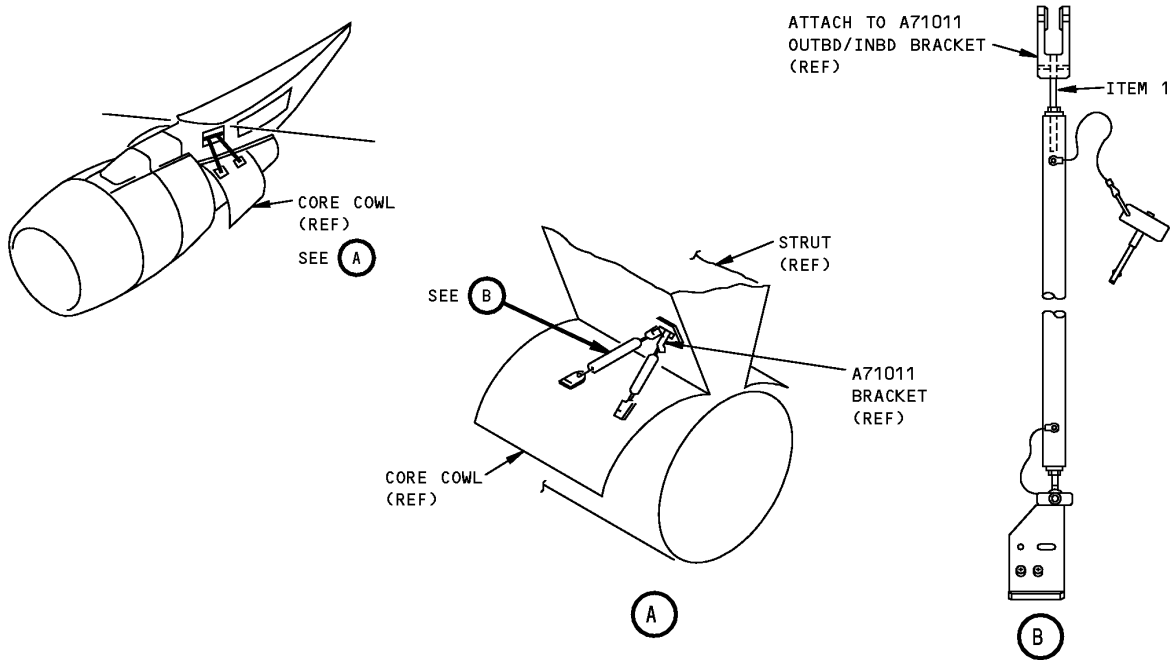

**CF6-80A, 40-Knot, Core Cowl Hold Open Equipment  
Figure 1**

REPAIRABLE/REPLACEABLE PARTS			
ITEM NO.	PART NO.	NOMENCLATURE	VENDOR CODE
1	A71033-11	ROD	



**ILLUSTRATED TOOL AND EQUIPMENT MANUAL**

**PART NUMBER: A71027-1**

**NAME:** HOLD OPEN EQUIPMENT - FAN COWL, 20 KNOTS, CF6-80A ENGINE

**AIRPLANE MAINTENANCE:** YES

**COMPONENT MAINTENANCE:** NO

**USAGE & DESCRIPTION:** The A71027-1 hold open equipment is used on 767 airplanes equipped with CF6-80A engines. A71027 is used with the A78001 thrust reverser hold open equipment to hold open the fan cowls during a CF6-80A engine change or during engine maintenance. A71027 is limited to winds of 20 knots or less. refer to the current A71027 drawing for complete usage instructions. A71027-1 consists of an A71027-2 left hand assembly and an A71027-3 right hand assembly.

**WEIGHT:** 51 lbs (23 kg)

**DIMENSIONS:** 12 x 24 x 65 inches (305 x 610 x 1651 mm)

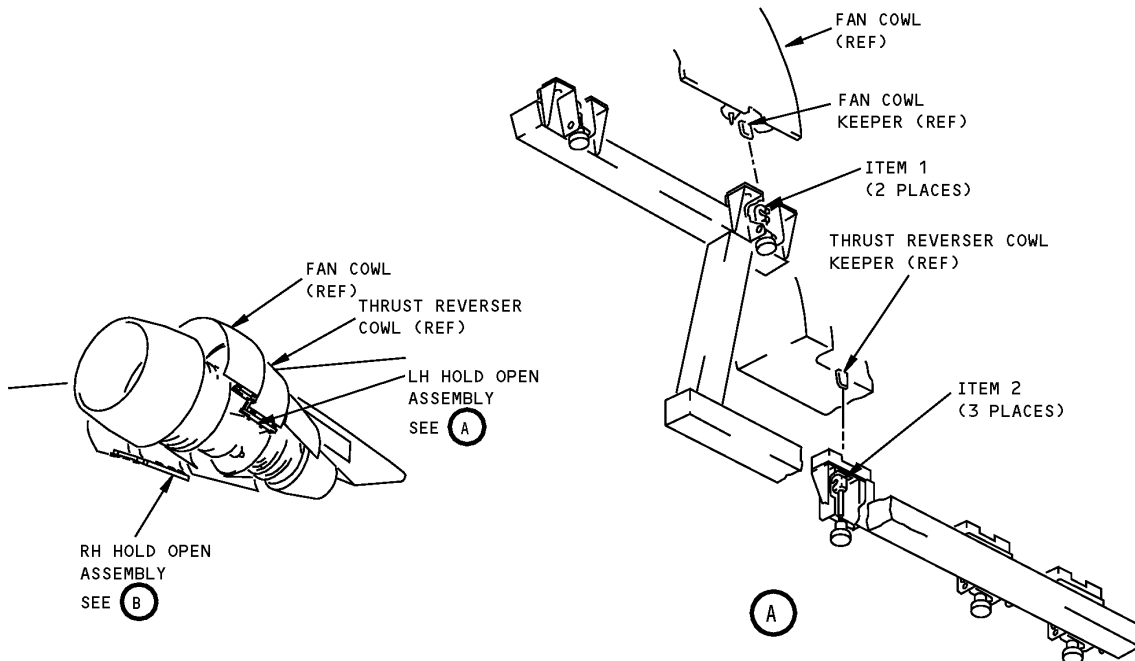

**CF6-80A Engine, 20 Knots, Fan Cowl Hold Open Equipment  
Figure 1 (Sheet 1 of 2)**

**767**  
**ILLUSTRATED TOOL AND EQUIPMENT MANUAL**

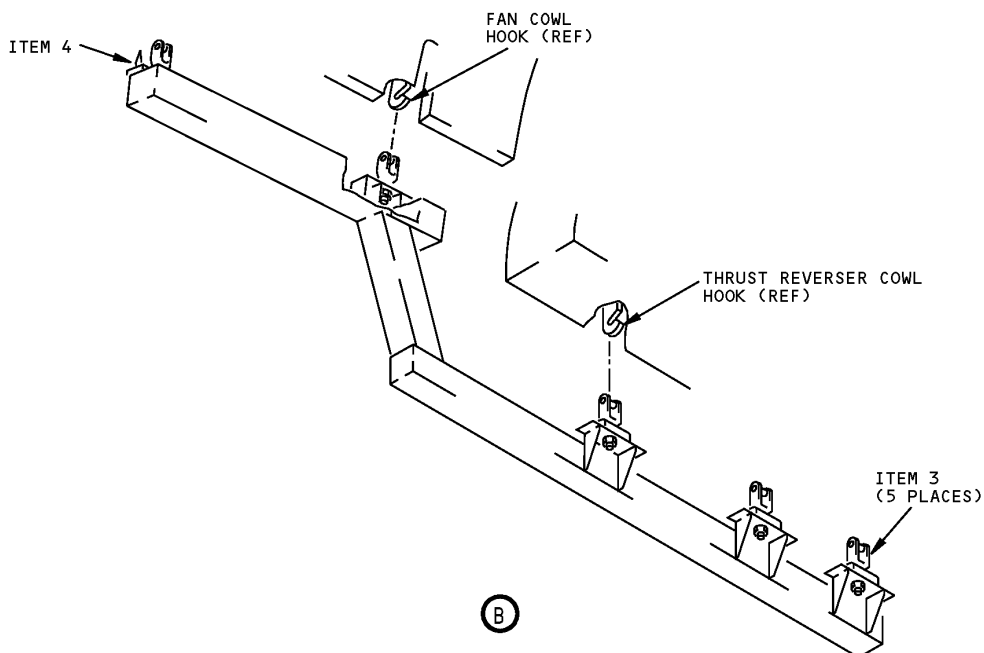

**CF6-80A Engine, 20 Knots, Fan Cowl Hold Open Equipment**  
**Figure 1 (Sheet 2 of 2)**

<b>REPAIRABLE/REPLACEABLE PARTS</b>			
<b>ITEM NO.</b>	<b>PART NO.</b>	<b>NOMENCLATURE</b>	<b>VENDOR CODE</b>
1	A71027-8	HOOK	
2	A71027-9	HOOK	
3	A71027-12	KEEPER ASSEMBLY	
4	A71027-13	PIN	



767

## ILLUSTRATED TOOL AND EQUIPMENT MANUAL

**PART NUMBER: B71040-36, -37, -39**

**NAME:** SLING EQUIPMENT - INLET COWL

**AIRPLANE MAINTENANCE:** YES

**COMPONENT MAINTENANCE:** NO

**USAGE & DESCRIPTION:** The B71040-36,-37 or -39 inlet cowl sling equipment is used on 767 airplanes equipped with RB211-524 engines. B71040 is used to remove or install the nose cowl from RB211-524 engines. The B71040-39 equipment also may be used on nose cowls of 737-600 thru -900 airplanes equipped with CFM56-7 engines. The only tooling difference for the CFM56-7 and the RB211-524 nose cowls is RB211-524 engines use B71040-24 lifting strap assemblies while the CFM56-7 engines use B71040-25 lifting strap assemblies. All B71040 sling equipment allows the nose cowl to be rotated from the engine installation position to flat (inlet side up). The optional Chain Bag (Part Number A1234-7) is for Morgan Aero Hoists only. For Ingersoll and Harrington Hoists, operator must secure compatible chain bag. Refer to AMM 71-11-01 for complete usage instructions. B71040 consists of:

<b>B71040-36</b>		
<b>QUANTITY</b>	<b>NOMENCLATURE</b>	<b>PART NUMBER</b>
1	LIFTING SLING ASSEMBLY	B71040-2
2	LIFTING BAR ASSEMBLY	B71040-3
2	CHAIN HOIST	B71040-40
2	CHAIN BAG	A1234-7
1	STORAGE BOX	

<b>B71040-37</b>		
<b>QUANTITY</b>	<b>NOMENCLATURE</b>	<b>PART NUMBER</b>
4	LIFTING STRAP ASSEMBLY	B71040-24
1	LIFTING SLING ASSEMBLY	B71040-32
2	CHAIN HOIST	B71040-40
2	CHAIN BAG	A1234-7
1	WELDLESS SLING LINK	G-341-5/8
1	STORAGE BOX	

<b>B71040-39</b>		
<b>QUANTITY</b>	<b>NOMENCLATURE</b>	<b>PART NUMBER</b>
4	LIFTING STRAP ASSEMBLY	B71040-24
4	LIFTING STRAP ASSEMBLY	B71040-25



767

**ILLUSTRATED TOOL AND EQUIPMENT MANUAL**

<b>B71040-39</b>		
<b>QUANTITY</b>	<b>NOMENCLATURE</b>	<b>PART NUMBER</b>
1	LIFTING SLING ASSEMBLY	B71040-32
2	CHAIN HOIST	B71040-40
2	CHAIN BAG	A1234-7
1	WELDLESS SLING LINK	G-341-5/8
1	STORAGE BOX	

**WEIGHT:** 120 lbs (54 kg)

**DIMENSIONS:** 18 x 24 x 120 inches (457 x 610 x 3048 mm)

**NOTE:** B71040-36, -37 and -39 supersede B71040-20, -21 and -23 respectively.  
B71040-39 replaces B71040-36 and -37 for future procurement.

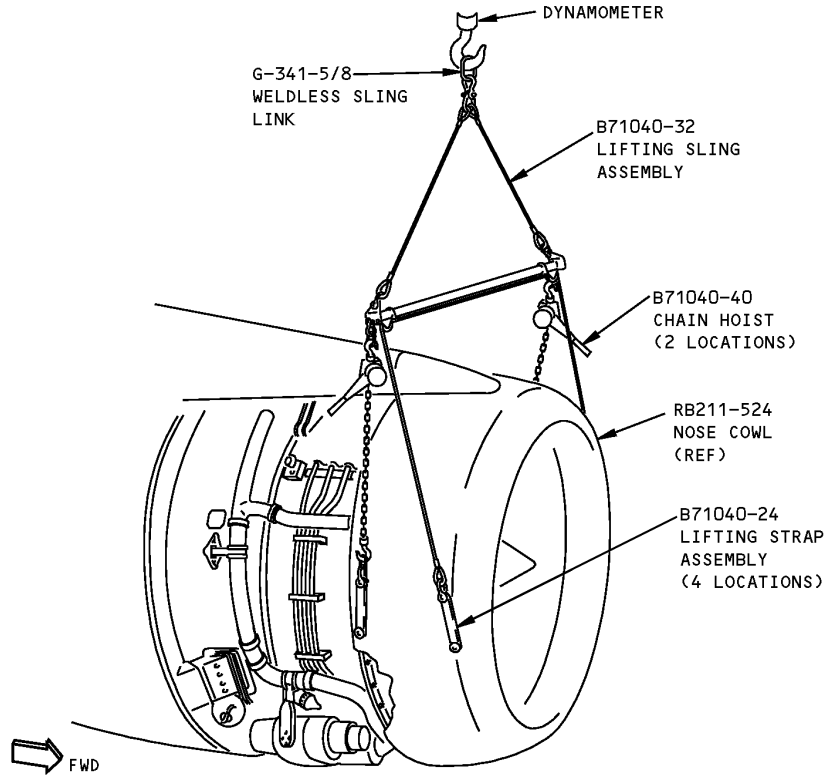

B71040-39 SLING EQUIPMENT SHOWN  
B71040-36 AND -37 SIMILAR

**Inlet Cowl Sling Equipment  
Figure 1 (Sheet 1 of 2)**

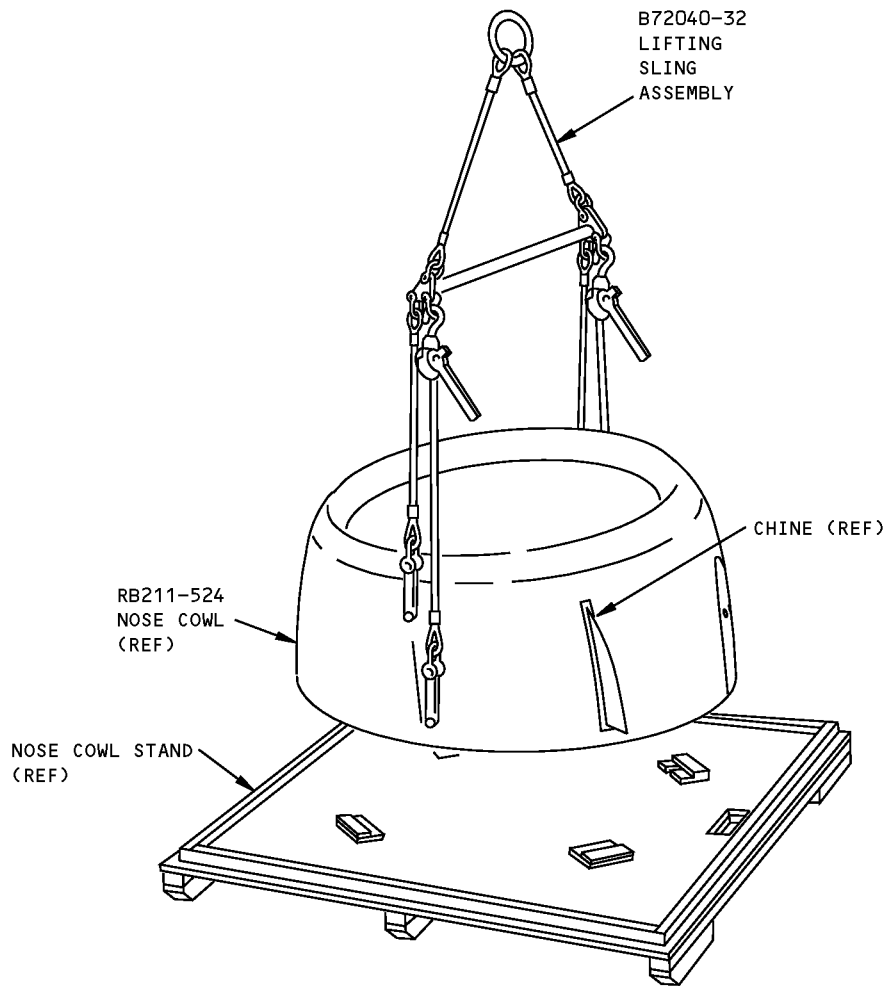

**Inlet Cowl Sling Equipment  
Figure 1 (Sheet 2 of 2)**



767

## ILLUSTRATED TOOL AND EQUIPMENT MANUAL

**PART NUMBER: G71023-52**

**NAME:** HOLD OPEN EQUIPMENT - 20 KNOT, PW4000 FAN AND CORE COWLS

**AIRPLANE MAINTENANCE:** YES

**COMPONENT MAINTENANCE:** NO

**USAGE & DESCRIPTION:** G71023-52 is used on 767 airplanes with PW4000 engines. G71023-52 hold open equipment is used to support the fan and core cowl of a PW4000 engine in an open position. G71023-52 usage is limited to 20 knots wind speed or less. Refer to AMM 71-00-02 for complete usage instructions. G71023-52 consists of two G71023-2 aft tube assemblies, a G71023-3 and -4 left and right core cowl attachment assemblies, a G71023-5 and -6 left and right thrust reverser attachment assemblies, a G71023-7 and -8 left and right forward tube assemblies and a G71023-9 and -10 left and right cowl attachment assemblies. All components are contained in a storage box.

**WEIGHT:** 66 lbs (30 kg)

**DIMENSIONS:** 7 x 26 x 58 inches (178 x 660 x 1473 mm)

**NOTE:** G71023-52 supersedes G71023-1.

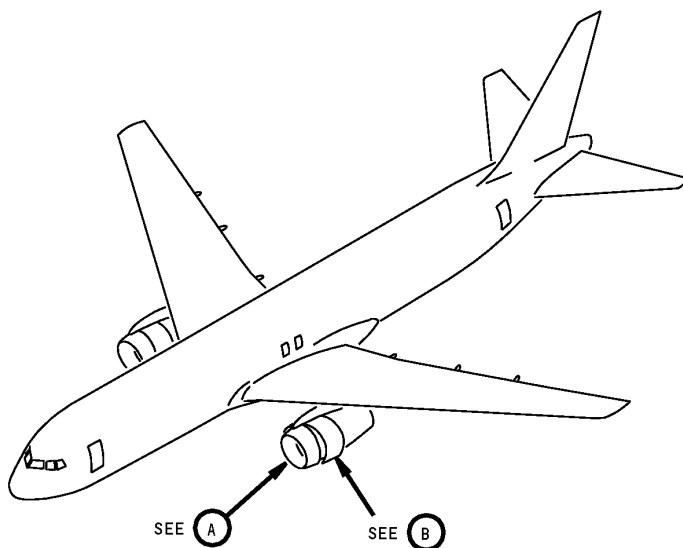

**PW4000 Fan And Core Cowls, 20 Knot, Hold Open Equipment  
Figure 1 (Sheet 1 of 2)**

**ILLUSTRATED TOOL AND EQUIPMENT MANUAL**

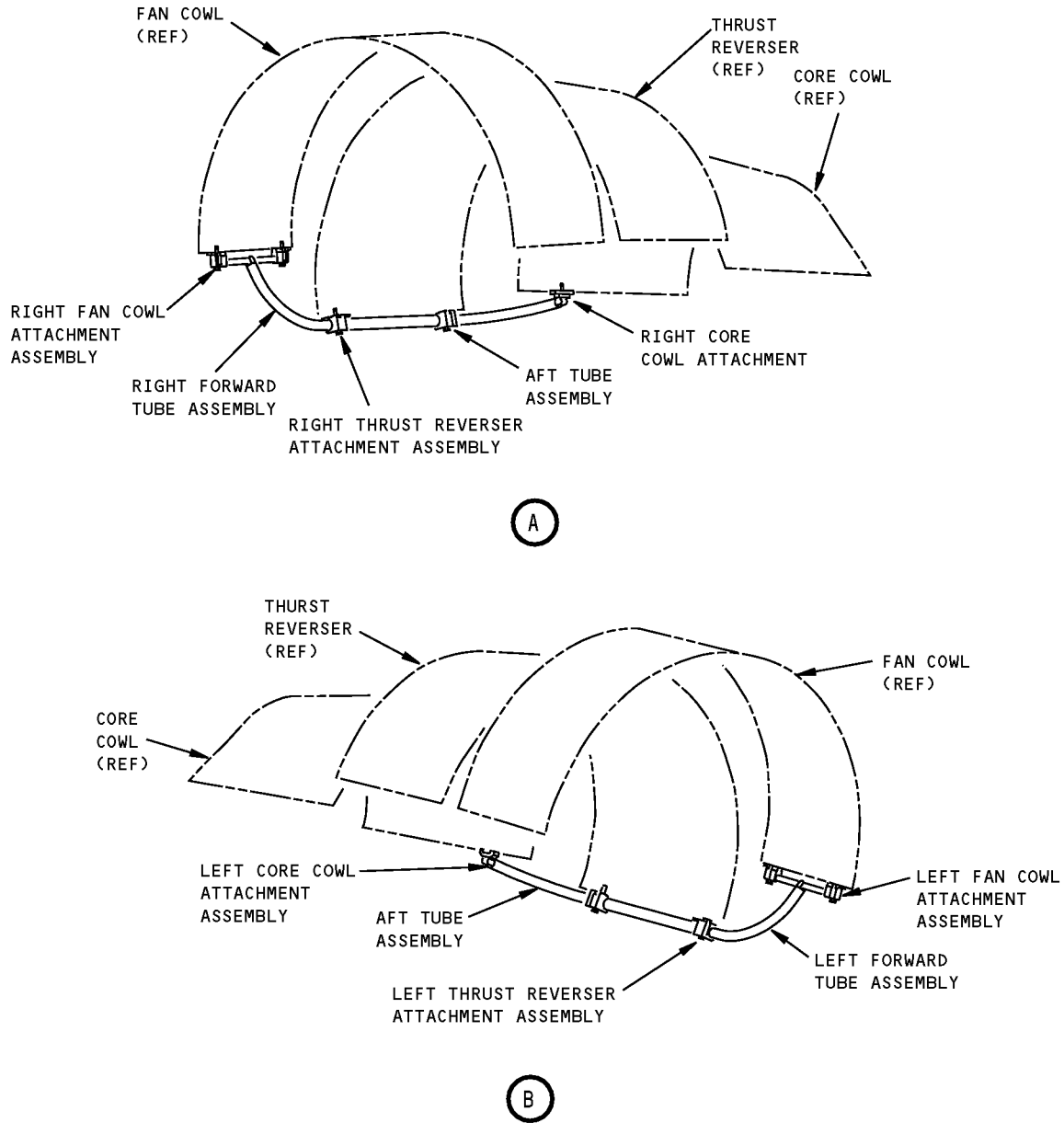

**PW4000 Fan And Core Cowls, 20 Knot, Hold Open Equipment  
Figure 1 (Sheet 2 of 2)**





767

## ILLUSTRATED TOOL AND EQUIPMENT MANUAL

**PART NUMBER: A78021-45, -46**

**NAME:** TEST/OVERHAUL EQUIPMENT - COWL DOOR ACTUATOR

**AIRPLANE MAINTENANCE:** NO

**COMPONENT MAINTENANCE:** YES

**USAGE & DESCRIPTION:** The A78021-45 or -46 is used during component maintenance on all 767 airplanes from line number 731 and on. The A78021-46 is also applicable to 767 airplanes if the SB 767-78-0083 has been incorporated. A78021 is used for test and overhaul procedures for the cowl door actuators. Refer to CMM 78-31-08 for complete usage instructions. A78021-45 and -46 consist of:

A78021-45		
QUANTITY	NOMENCLATURE	PART NUMBER
1	TEST FIXTURE	A78021-47
1	SPRING COMPRESSOR	A78021-3
1	CAP WRENCH	A78021-4
2	HOLDING BLOCK	A78021-5
1	SOCKET ROD	A78021-6
2	PISTON RETAINER	A78021-7
1	STORAGE BOX	

A78021-46		
QUANTITY	NOMENCLATURE	PART NUMBER
1	TEST FIXTURE	A78021-47
1	SPRING COMPRESSOR	A78021-3
1	CAP WRENCH	A78021-4
2	HOLDING BLOCK	A78021-5
1	SOCKET ROD	A78021-6
2	PISTON RETAINER	A78021-7
1	PISTON PULLER ASSEMBLY	A78021-48
1	CAP WRENCH ASSEMBLY	A78021-33
1	RESERVOIR SIZING TOOL	A78021-34
1	SIZING TOOL	A78021-35
1	SEAL SLIDE	A78021-36
1	RESERVOIR SEAL SLIDE	A78021-37
1	GLAND WRENCH	A78021-38



767

**ILLUSTRATED TOOL AND EQUIPMENT MANUAL**

A78021-46		
QUANTITY	NOMENCLATURE	PART NUMBER
1	GUIDE	A78021-41
1	PISTON HOLDER ASSEMBLY	A78021-49
1	STORAGE BOX	

**WEIGHT:** 500 lbs (227 kg)

**DIMENSIONS:** 24 x 24 x 68 inches (610 x 610 x 1727 mm)

**NOTE:** A78021-46 replaces A78021-45 for future procurement.  
A78021-46 supersedes A78021-31.  
A78021-45 supersedes A78021-1.

**767  
ILLUSTRATED TOOL AND EQUIPMENT MANUAL**

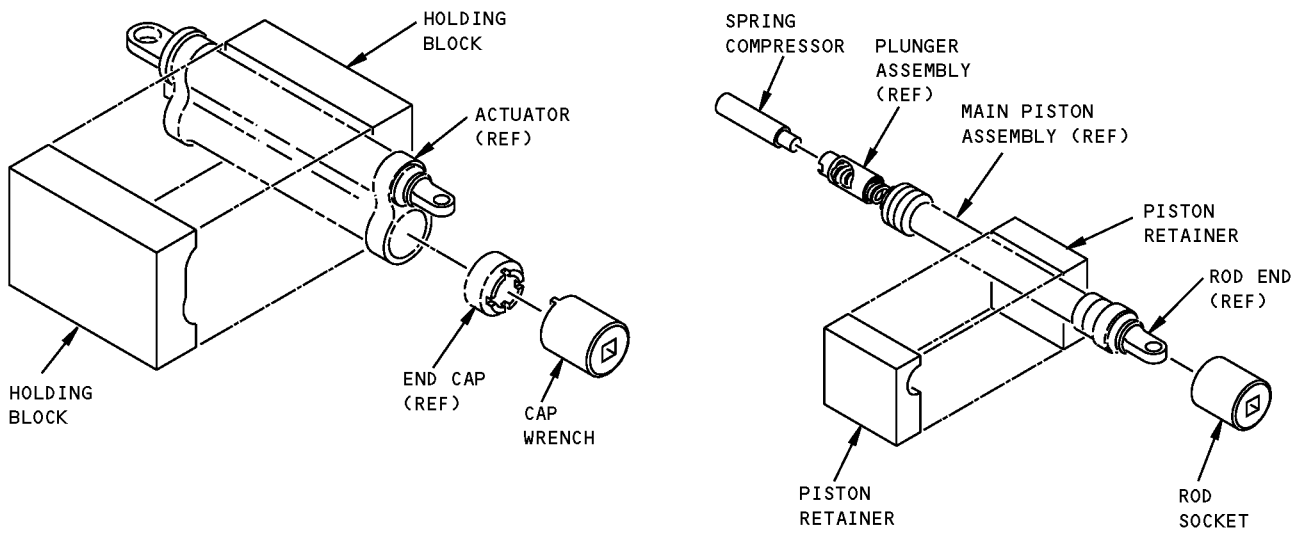

A78021-45,-46

**Cowl Door Actuator Test/Overhaul Equipment  
Figure 1 (Sheet 1 of 3)**

**ILLUSTRATED TOOL AND EQUIPMENT MANUAL**

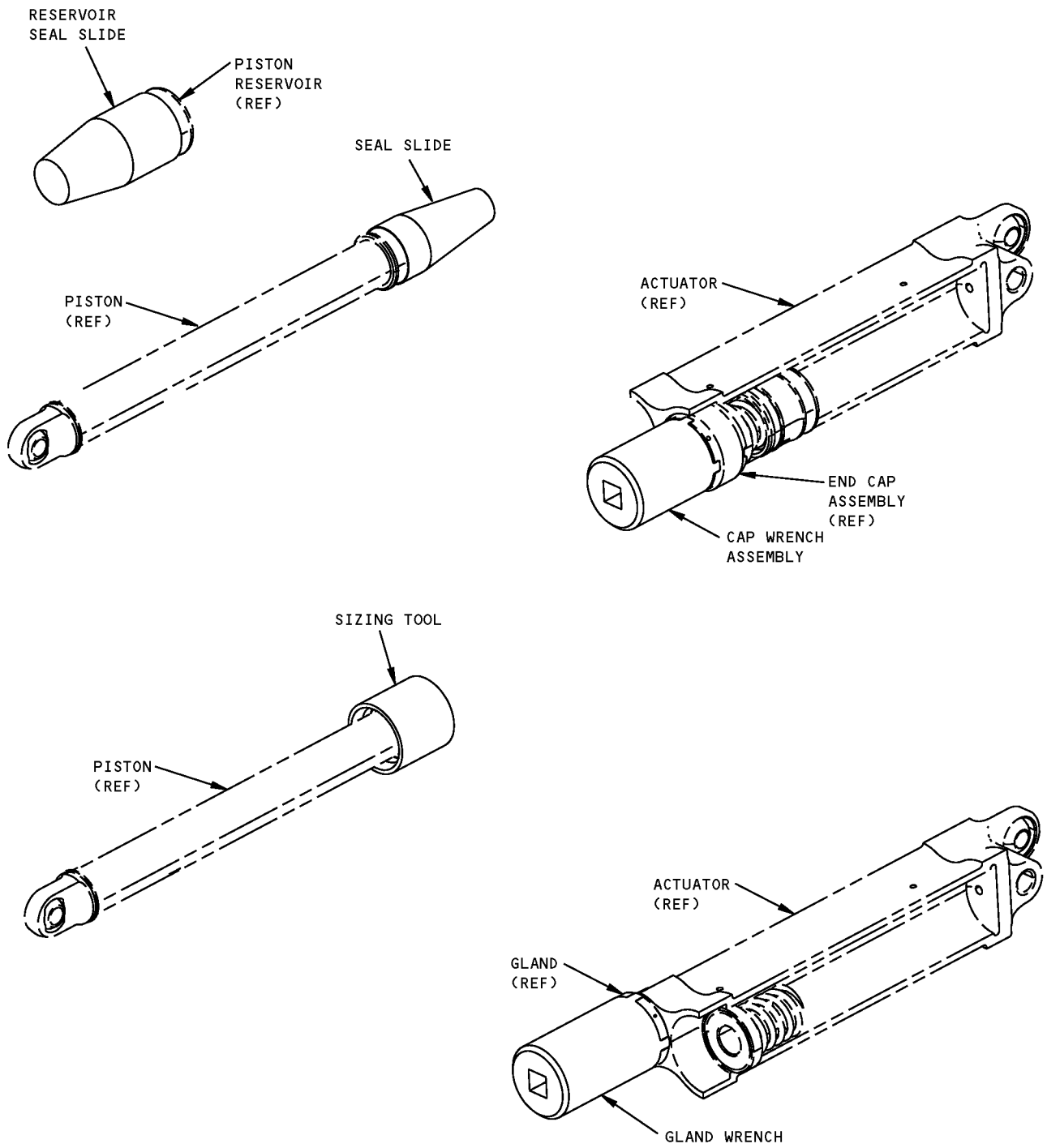

A78021-46

**Cowl Door Actuator Test/Overhaul Equipment  
Figure 1 (Sheet 2 of 3)**

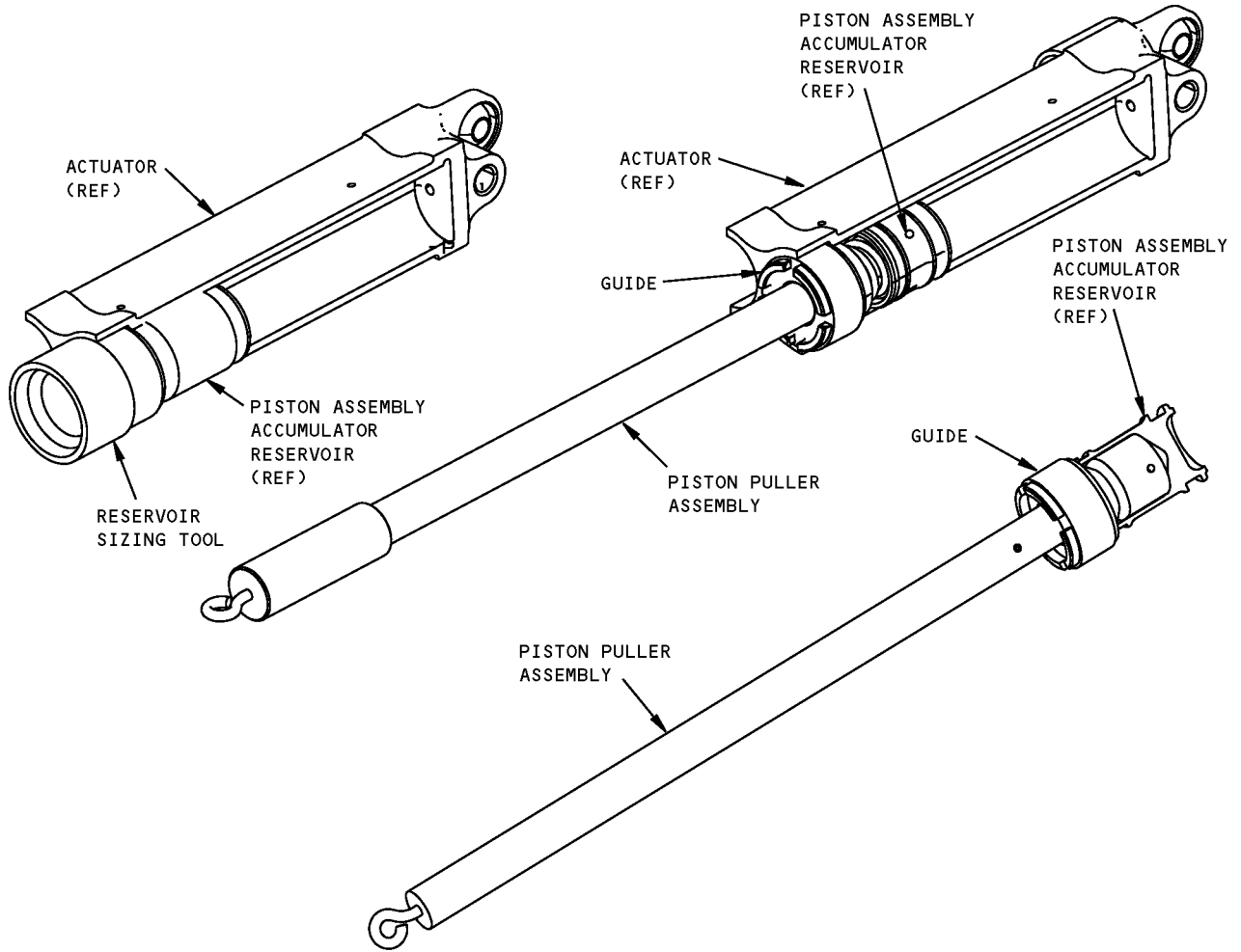

A78021-46

**Cowl Door Actuator Test/Overhaul Equipment  
Figure 1 (Sheet 3 of 3)**

ILLUSTRATED TOOL AND EQUIPMENT MANUAL

PART NUMBER: A71050-1

**NAME:** HOLD OPEN BRACKET - JT9D ENGINE

**AIRPLANE MAINTENANCE:** YES

**COMPONENT MAINTENANCE:** NO

**USAGE & DESCRIPTION:** The A71050-1 hold open bracket is used on 767 airplanes equipped with JT9D engines. A71050 is used to facilitate engine removal and replacement. Refer to the current A71050 drawing for complete usage instructions. A71050-1 consists of an A71050-2 bracket assembly contained in a storage box.

**WEIGHT:** 2.3 lbs (1 kg)

**DIMENSIONS:** 3.0 x 4.0 x 5.0 inches (76 x 102 x 127 mm)

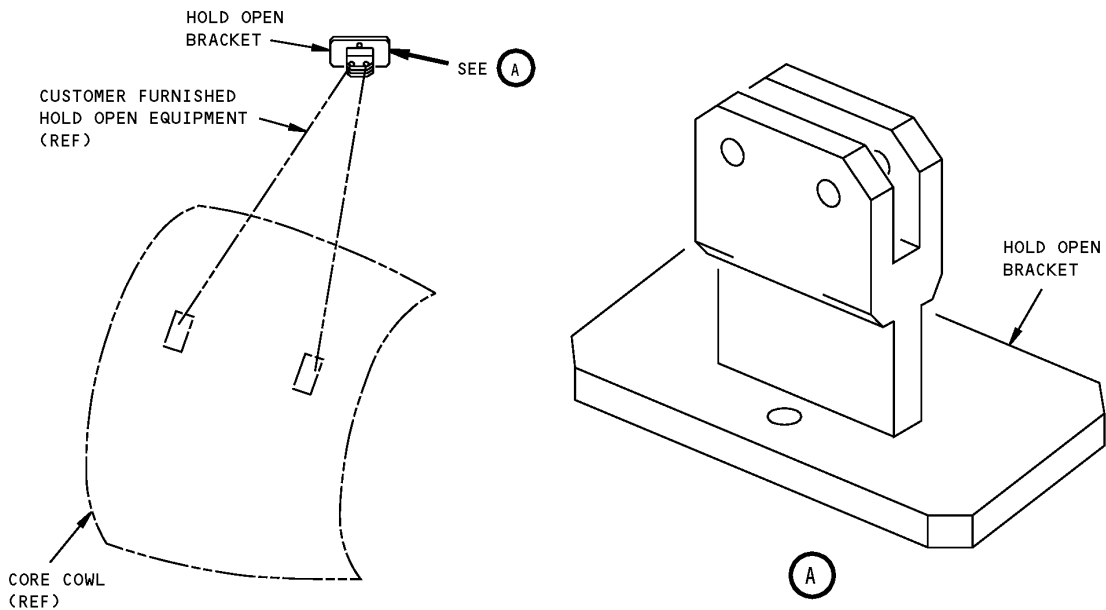

**JT9D Engine Hold Open Bracket  
Figure 1**

## ILLUSTRATED TOOL AND EQUIPMENT MANUAL

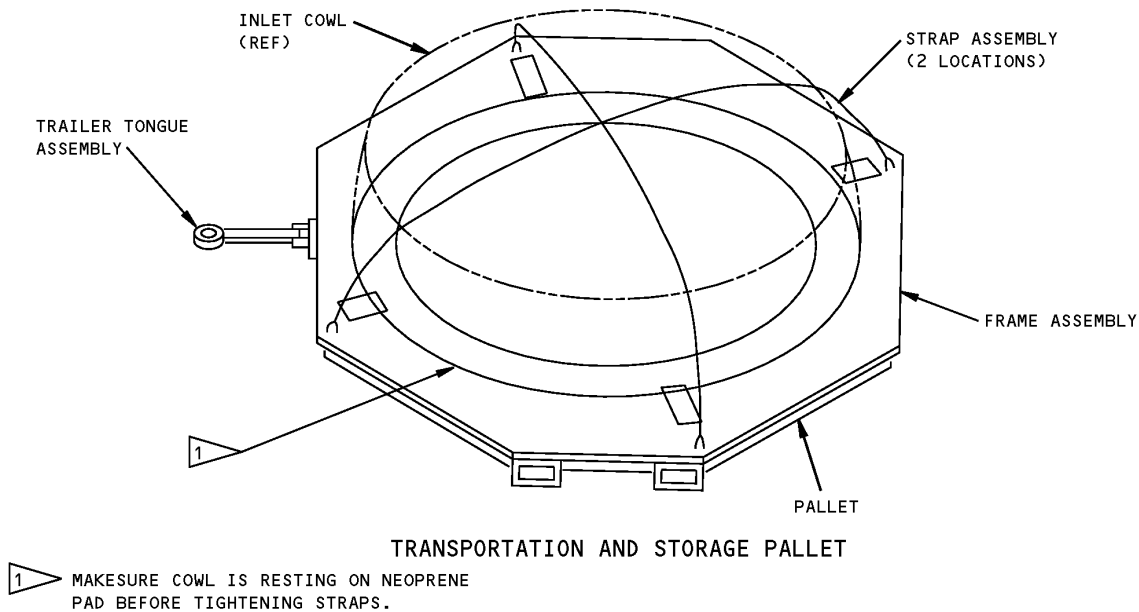
**PART NUMBER: A71051-1****NAME:** TRANSPORTATION AND STORAGE PALLET - INLET COWL, CF6-80C2B ENGINE**AIRPLANE MAINTENANCE:** YES**COMPONENT MAINTENANCE:** NO**USAGE & DESCRIPTION:** The A71051-1 transportation and storage pallet is used on 767 airplanes equipped with CF6-80C2B engines. A71051 pallet is mounted on casters with straps to hold inlet cowl in place. A71051 is used to support the CF6-80C2B inlet cowl for storage or routine handling. Refer to the current A71051 drawing for complete usage instructions. A71051-1 consists of an A71051-2 frame assembly, an A00003-1 trailer tongue assembly, two 522770 strap assemblies, two 4-5108-439 rigid casters, two 4-5109-439 swivel casters and related hardware.**WEIGHT:** 970 lbs (440 kg)**DIMENSIONS:** 13 x 120 x 124 inches (330 x 3048 x 3150 mm)

**CF6-80C2B Engine Inlet Cowl, Transportation And Storage Pallet**  
**Figure 1**

**ILLUSTRATED TOOL AND EQUIPMENT MANUAL**

**PART NUMBER: G71032-1**

**NAME:** SLING EQUIPMENT - INLET COWL, CF6-50 AND RB211-524 ENGINES

**AIRPLANE MAINTENANCE:** YES

**COMPONENT MAINTENANCE:** NO

**USAGE & DESCRIPTION:** The G71032-1 sling equipment is used on all 767 airplanes equipped with RB211-524 engines. G71032 is used to lift the inlet cowl to and from transportation equipment and to remove or install the inlet cowl. Refer to AMM 71-11-01 for complete usage instructions. G71032-1 consists of a G71032-2 sling assembly contained in a storage box.

**WEIGHT:** 150 lbs (68 kg)

**DIMENSIONS:** 16 x 24 x 112 inches (406 x 610 x 2845 mm)

**NOTE:** G71032 supersedes 20HME65B94200-1.  
G71030 replaces G71032 for future procurement.

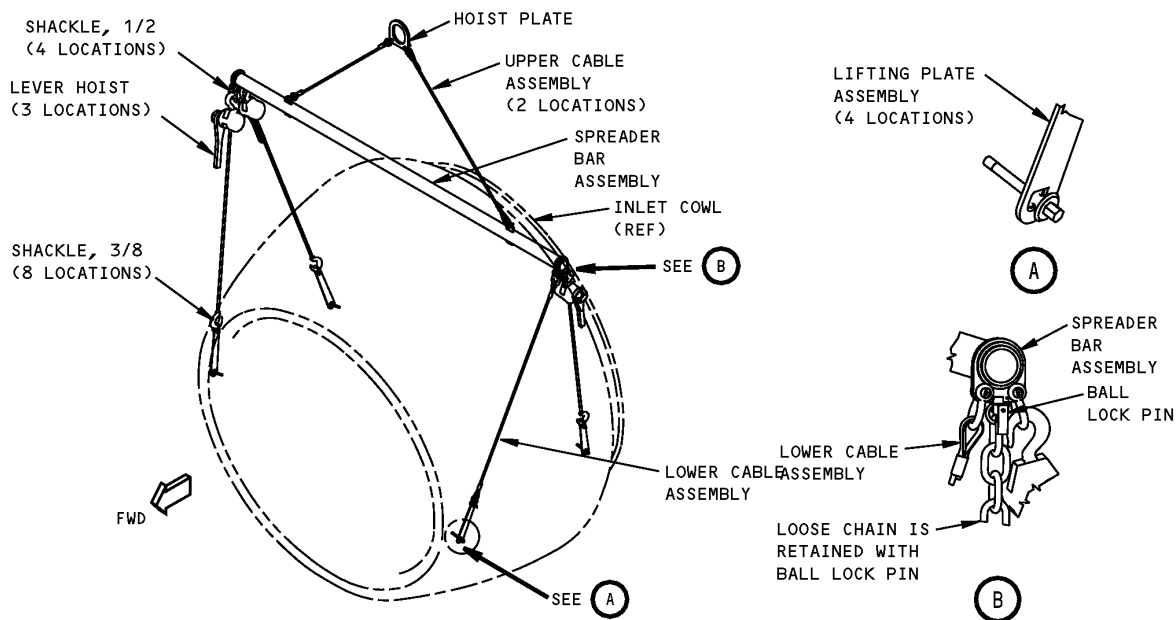

**CF6-50 and RB211-524 Engine Inlet Cowl Sling Equipment  
Figure 1**





767

**ILLUSTRATED TOOL AND EQUIPMENT MANUAL**

**PART NUMBER: 20HME65B94200-1 WAS DELETED**

**ILLUSTRATED TOOL AND EQUIPMENT MANUAL**

**PART NUMBER: G71030-1**

**NAME:** SLING EQUIPMENT - NOSE COWL, RB211-524 AND CF6-50 ENGINES

**AIRPLANE MAINTENANCE:** YES

**COMPONENT MAINTENANCE:** NO

**USAGE & DESCRIPTION:** The G71030-1 sling equipment is used on 767-300ER airplanes. G71030 is used to transfer the nose cowl from shipping to the installation position and reverse. Refer to AMM 71-00-02 for complete usage instructions. G71030-1 consists of a G71030-2 sling assembly contained in a storage box .

**WEIGHT:** 125 lbs (57 kg)

**DIMENSIONS:** 12 X 18 X 109 inches (305 x 457 x 2769 mm)

**NOTE:** G71030 supersedes 30HME65B89603.  
G71030 replaces G71032 for future procurement.

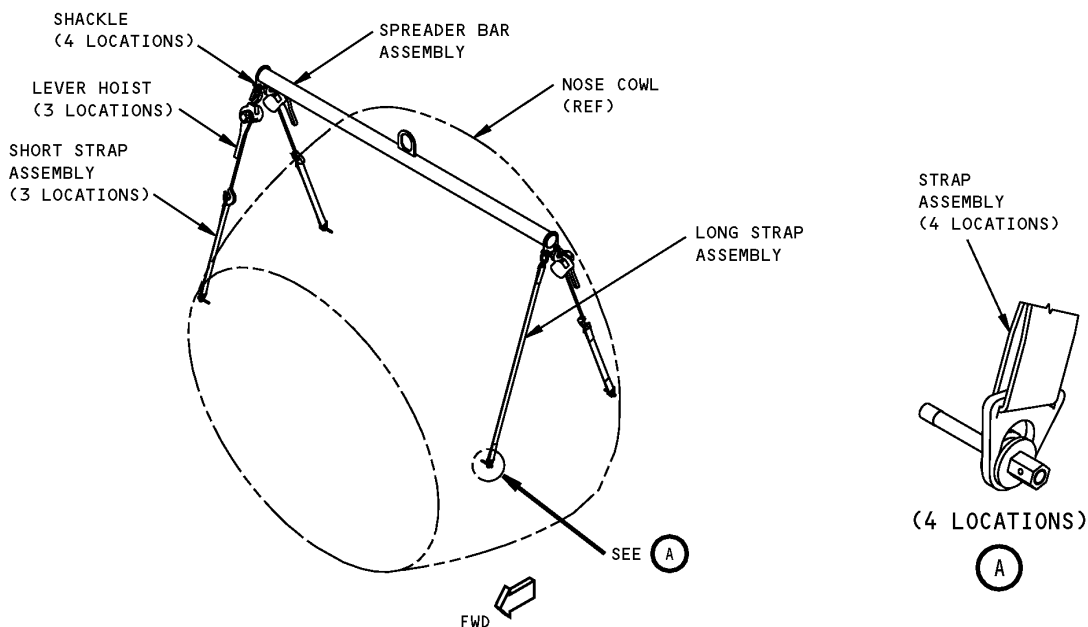

**RB211-524 and CF6-50 Engines Nose Cowl Sling Equipment  
Figure 1**

## ILLUSTRATED TOOL AND EQUIPMENT MANUAL

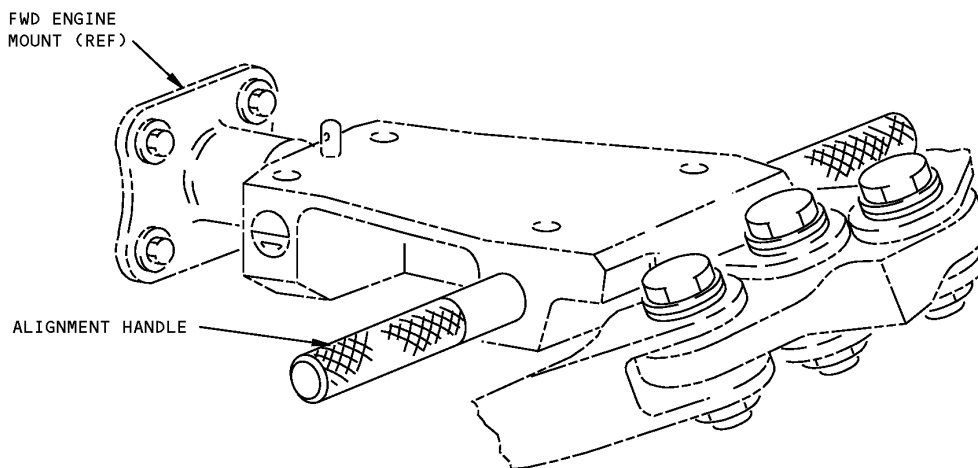
**PART NUMBER: A71038-1****NAME:** ALIGNMENT HANDLE - FORWARD ENGINE MOUNT**AIRPLANE MAINTENANCE:** YES**COMPONENT MAINTENANCE:** NO**USAGE & DESCRIPTION:** A71038-1 alignment handle is used on all 767 airplanes equipped with JT9D-7R4 engines. A71038 is used to align the JT9D-7R4 forward engine mount during engine installation. Refer to AMM 71-00-02 for complete usage instructions. A71038-1 consists of an A71038-2 handle contained in a storage box.**WEIGHT:** 3 lbs (1.4 kg)**DIMENSIONS:** 2 x 4 x 18 inches (51 x 102 x 457 mm)

**Forward Engine Mount Alignment Handle  
Figure 1**