

CHAPTER

77

ENGINE INDICATING



767

ILLUSTRATED TOOL AND EQUIPMENT MANUAL

CHAPTER 77 ENGINE INDICATING

Subject/Page	Date	Subject/Page	Date	Subject/Page	Date
EFFECTIVE PAGES					
1	Apr 10/2008				
2	BLANK				
77-CONTENTS					
1	Apr 10/2006				
2	BLANK				
77-10-01					
1	Apr 10/2007				
2	Apr 10/2006				
3	Apr 10/2006				
4	Apr 10/2006				
5	Oct 10/2007				
6	Apr 10/2006				
7	Apr 10/2006				
8	Apr 10/2006				
9	Oct 10/2007				
10	BLANK				
77-10-02					
1	Apr 10/2006				
2	Apr 10/2006				
3	Apr 10/2006				
4	Apr 10/2006				
5	Apr 10/2006				
6	BLANK				
77-20-01					
1	Apr 10/2006				
2	BLANK				
77-30-01					
1	Apr 10/2006				
2	Apr 10/2006				
77-30-02					
1	Oct 10/2006				
2	Apr 10/2006				
77-30-03					
1	Apr 10/2006				
2	BLANK				

A = Added, R = Revised, O = Overflow, D = Deleted

77-EFFECTIVE PAGES

Page 1
Apr 10/2008

D634T501



767

ILLUSTRATED TOOL AND EQUIPMENT MANUAL

TABLE OF CONTENTS

<u>Subject</u>	<u>Title</u>	<u>Part No.</u>
77-	ENGINE INDICATING	
77-10-01	TEST BOX - TACHOMETER SYSTEM	A77004-18, -19
77-10-02	TEST EQUIPMENT - ENGINE N1 AND N2 INTERFACE	A77005-59, -60, -61
77-20-01	TEST EQUIPMENT - INDICATING SYSTEM, EXHAUST GAS TEMPERATURE (EGT)	A77003-18
77-30-01	TEST BOX - ELECTRONIC ENGINE CONTROL MONITOR POWER SUPPLY	A77001-1
77-30-02	TEST BOX - DISPLAY BOARD, ELECTRONIC ENGINE CONTROL MONITOR	A77002-1
77-30-03	TEST BOX - GENERIC AIRBORNE VIBRATION MONITOR (AVM) INTERFACE	C77004-10

77-CONTENTS



767

ILLUSTRATED TOOL AND EQUIPMENT MANUAL

PART NUMBER: A77004-18, -19

NAME: TEST BOX - TACHOMETER SYSTEM

AIRPLANE MAINTENANCE: YES

COMPONENT MAINTENANCE: NO

USAGE & DESCRIPTION: The A77004-18 test box is used on 767-200, -200ER, and -300 airplanes equipped with CF6-80A engines. The A77004-19 test box is used on 767-200, -200ER, and -300 airplanes equipped with JT9D-7R4D or JT9D-7R4E engines. A77004, together with a customer-furnished signal generator and frequency counter, is used to functionally test the N1/N2 tachometer system. On 767-200, -200ER, and -300 airplanes equipped with CF6-80A engines, refer to AMM 77-12-01, AMM 77-12-02 and the current A77004 drawing for complete usage instructions. On 767-200, -200ER, and -300 airplanes equipped with JT9D-7R4D/E engines, refer to AMM 77-12-00 and the current A77004 drawing for complete usage instructions.

A77004-18 consists of an A77004-20 box assembly and an A77004-22 cable assembly, both contained in a storage box.

A77004-19 consists of an A77004-21 box assembly and an A77004-23 cable assembly, both contained in a storage box.

WEIGHT: 4 lbs (1.8 kg)

DIMENSIONS: 12 x 12 x 10 inches (305 x 305 x 254 mm)

NOTE: A77004-18 and -19 supersedes A77004-1 and -2, respectively.

767
ILLUSTRATED TOOL AND EQUIPMENT MANUAL

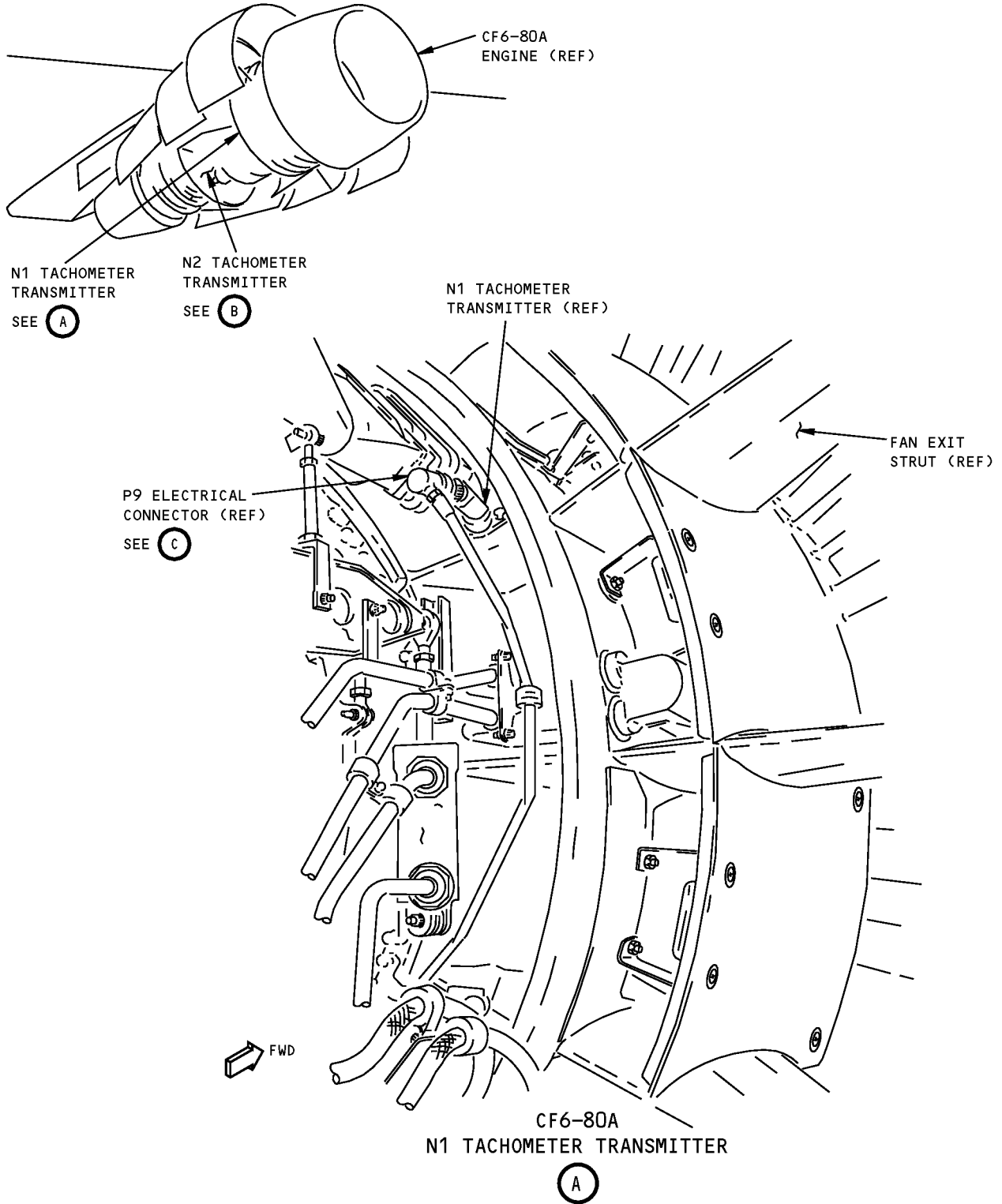

A77004-18 Tachometer System Test Box
Figure 1 (Sheet 1 of 3)

767
ILLUSTRATED TOOL AND EQUIPMENT MANUAL

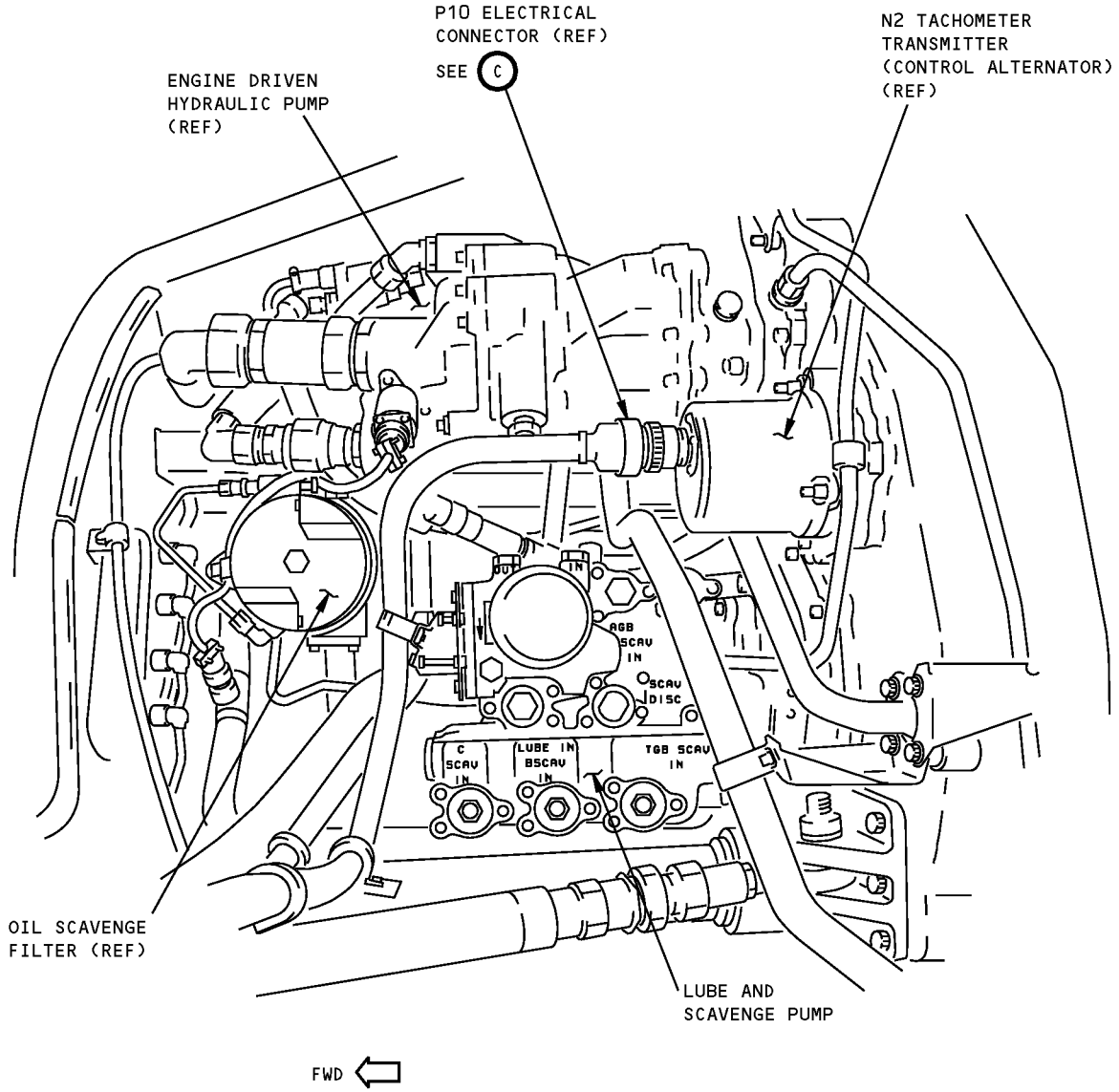

CF6-80A
N2 TACHOMETER TRANSMITTER

(B)

A77004-18 Tachometer System Test Box
Figure 1 (Sheet 2 of 3)

ILLUSTRATED TOOL AND EQUIPMENT MANUAL

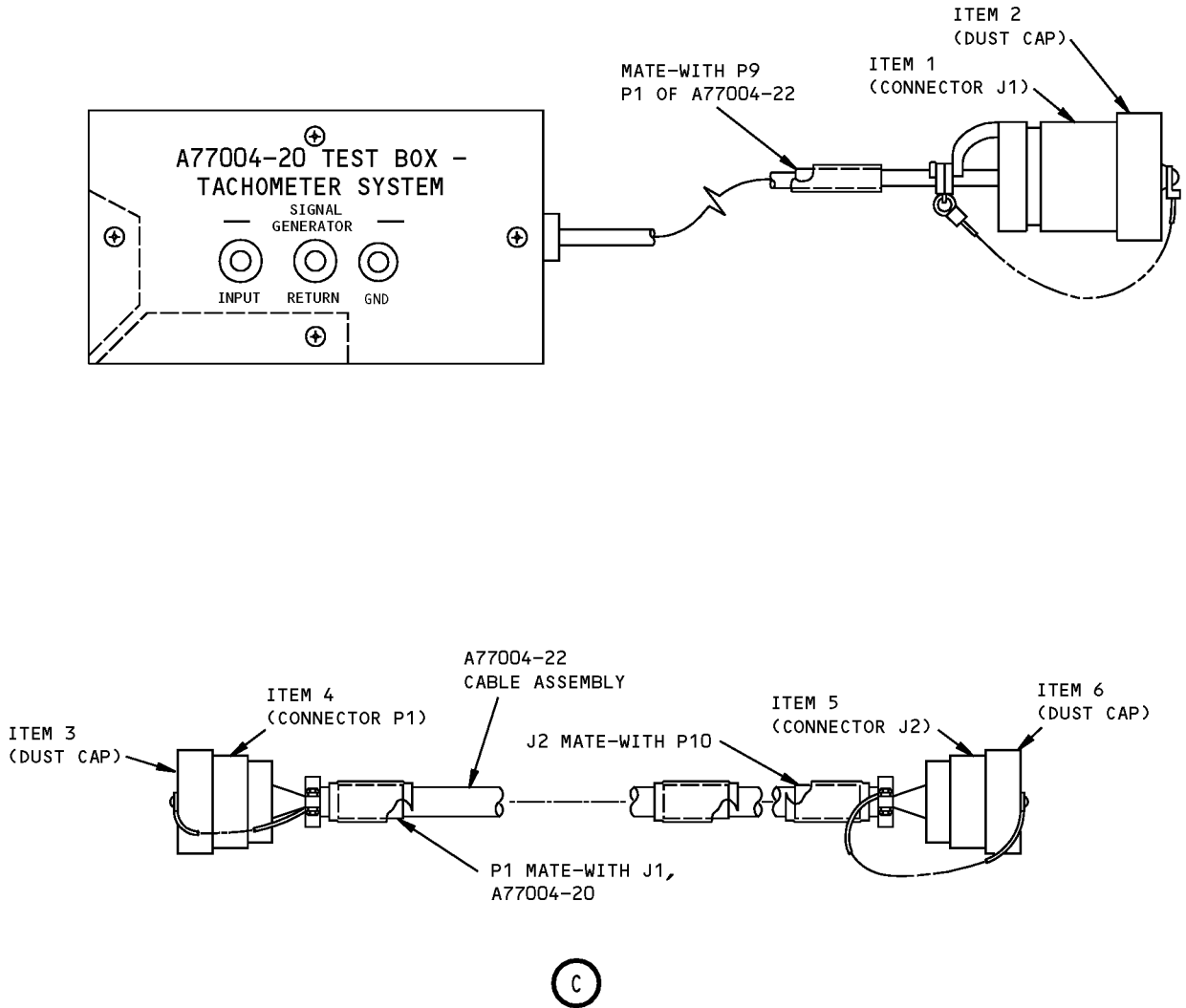

**A77004-18 Tachometer System Test Box
Figure 1 (Sheet 3 of 3)**



767

ILLUSTRATED TOOL AND EQUIPMENT MANUAL

A77004-18 TEST BOX, REPAIRABLE/REPLACEABLE PARTS			
ITEM NO.	PART NO.	NOMENCLATURE	VENDOR CODE
1	M83723/83R1056	CONNECTOR	
2	M83723/60-110AC	DUST CAP	
3	M83723/59-110AC	DUST CAP	
4	M83723/86R1056	CONNECTOR	
5	M83723/83R1610N	CONNECTOR	
6	M83723/60-116AC	DUST CAP	

**767
ILLUSTRATED TOOL AND EQUIPMENT MANUAL**

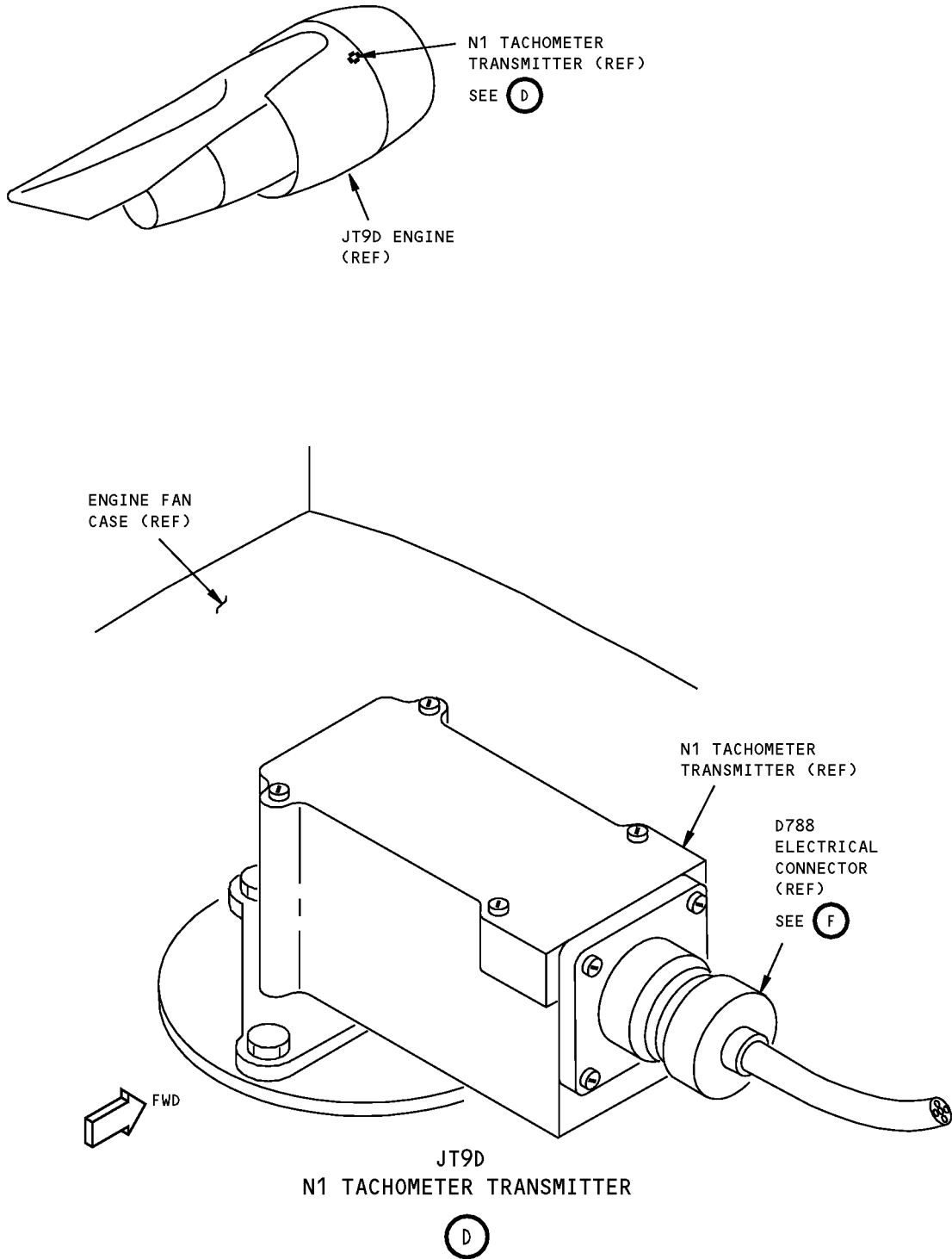

**A77004-19 Tachometer System Test Box
Figure 2 (Sheet 1 of 3)**

**767
ILLUSTRATED TOOL AND EQUIPMENT MANUAL**

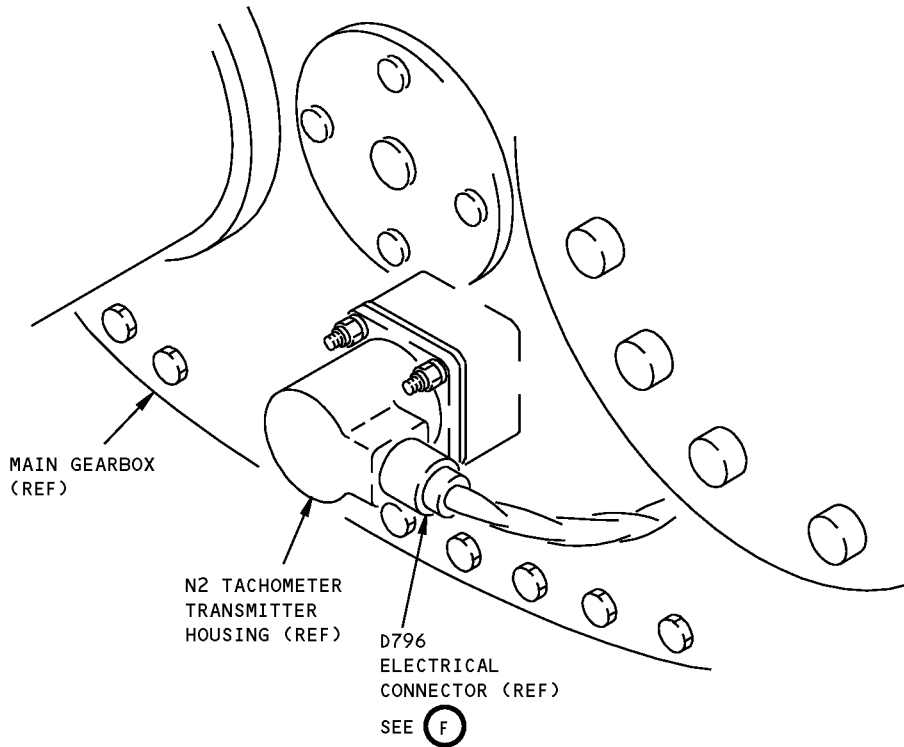
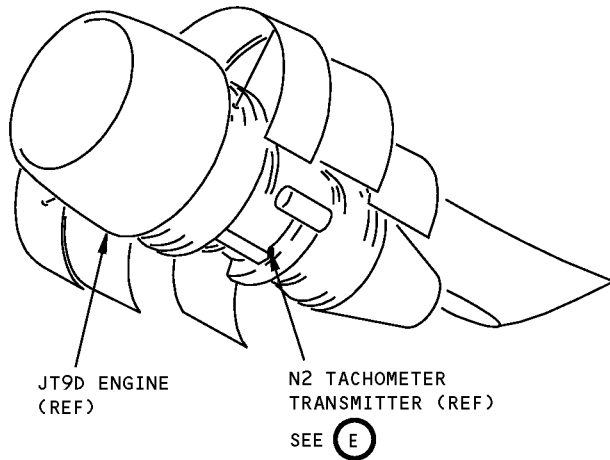

JT9D
N2 TACHOMETER TRANSMITTER

(E)

**A77004-19 Tachometer System Test Box
Figure 2 (Sheet 2 of 3)**

ILLUSTRATED TOOL AND EQUIPMENT MANUAL

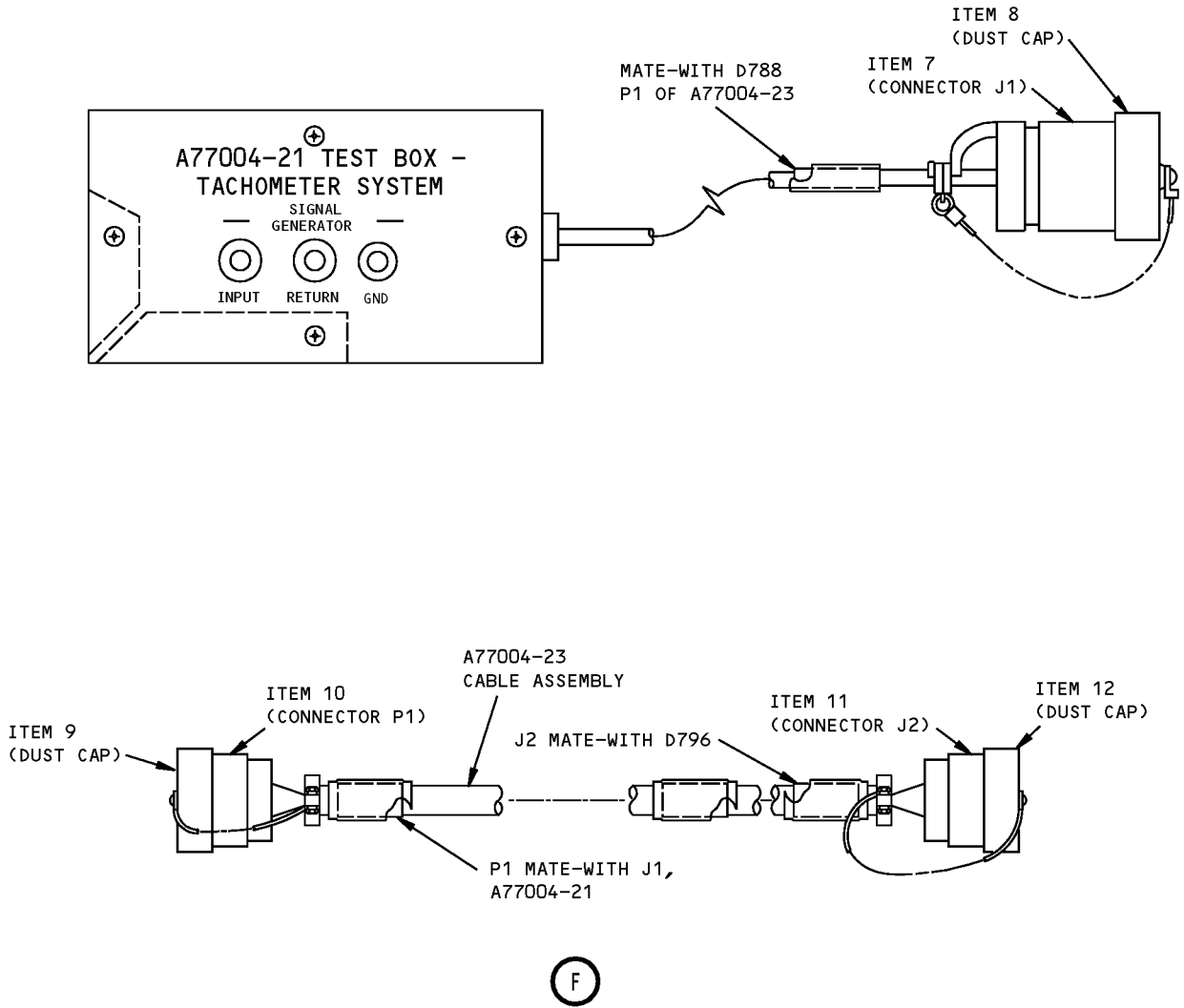

**A77004-19 Tachometer System Test Box
Figure 2 (Sheet 3 of 3)**



767

ILLUSTRATED TOOL AND EQUIPMENT MANUAL

A77004-19 TEST BOX, REPAIRABLE/REPLACEABLE PARTS			
ITEM NO.	PART NO.	NOMENCLATURE	VENDOR CODE
7	M83723/83R1476	CONNECTOR	
8	M83723/60-114AC	DUST CAP	
9	M83723/59-114AC	DUST CAP	
10	M83723/86R1476	CONNECTOR	
11	M83723/83R123N	CONNECTOR	
12	M83723/60-112AC	DUST CAP	



767

ILLUSTRATED TOOL AND EQUIPMENT MANUAL

PART NUMBER: A77005-59, -60, -61

NAME: TEST EQUIPMENT - ENGINE N1 AND N2 INTERFACE

AIRPLANE MAINTENANCE: YES

COMPONENT MAINTENANCE: NO

USAGE & DESCRIPTION: The A77005-59 test equipment is used on 767 airplanes with CF6-80C2 (PMC, non-FADEC). The A77005-60 test equipment is used on 767 airplanes with (PMC, non-FADEC) and CF6-80C2 (FADEC). The A77005-61 test equipment is used on 767 airplanes with CF6-80C2 (FADEC only). A77005 is used to provide N1 and N2 interface to perform engine tachometer system adjustment test on CF6-80C2 (FADEC and Non-FADEC) series engines. Refer to AMM 77-12-00 and AMM 77-31-00 for complete usage instructions. The A77005-59 consists of a A77005-67 test box contained in a storage box. The A77005-60 consists of a A77005-68 test box, a A77005-39 cable assembly, a A77005-40 cable assembly, all contained in a storage box. The A77005-61 consists of a A77005-69 test box contained in a storage box.

WEIGHT: 10 lbs (4.5 kg)

DIMENSIONS: 6 x 10 x 15 inches (152 x 254 x 381 mm)

NOTE: A77005-59,-60 and -61 supersedes A77005-24,-37 and -52 respectively.

767
ILLUSTRATED TOOL AND EQUIPMENT MANUAL

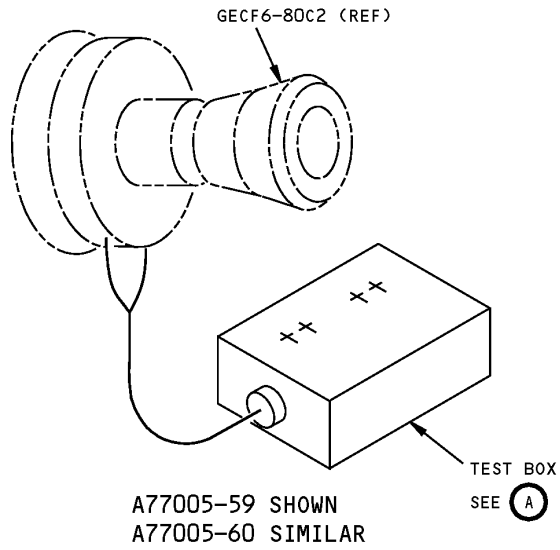

Engine N1 and N2 Interface Equipment
Figure 1 (Sheet 1 of 4)

**767
ILLUSTRATED TOOL AND EQUIPMENT MANUAL**

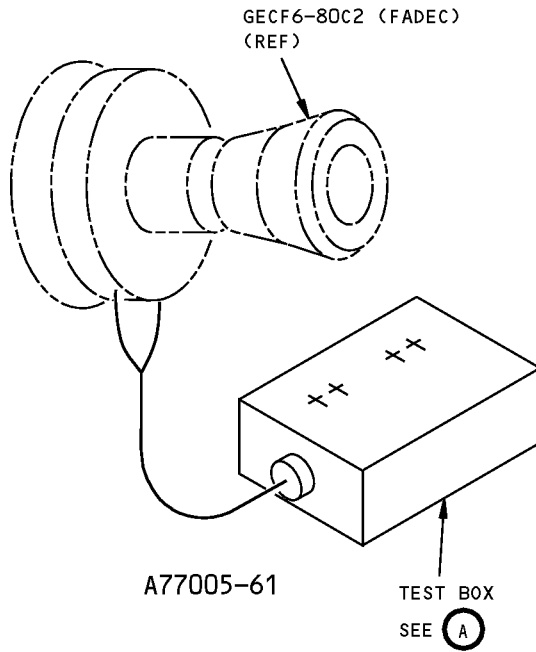
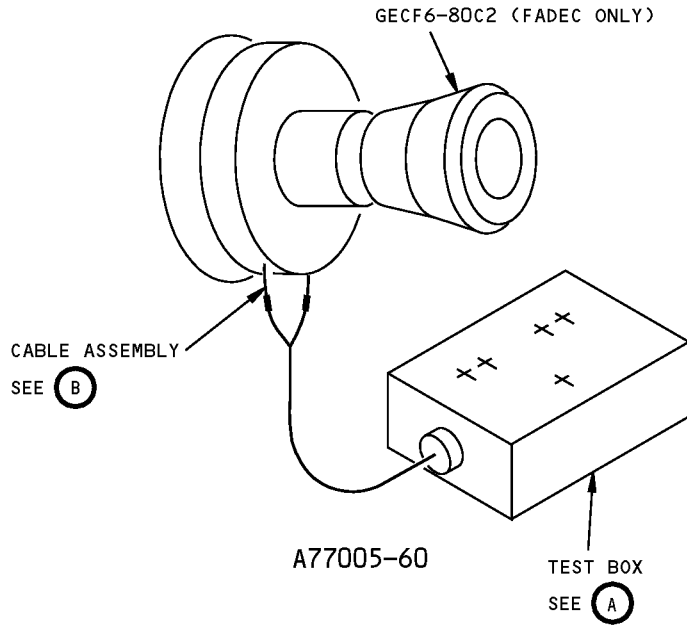

**Engine N1 and N2 Interface Equipment
Figure 1 (Sheet 2 of 4)**

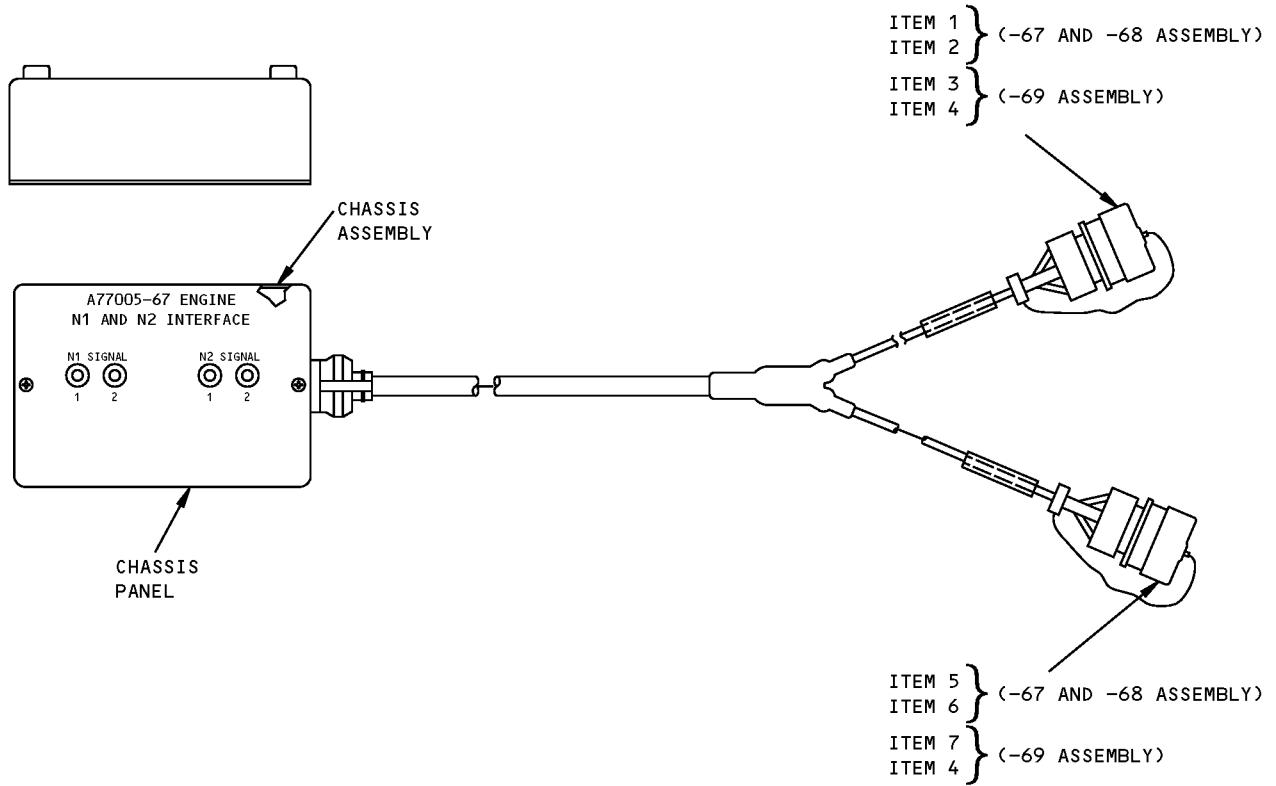

A77005-67 TEST BOX SHOWN
A77005-68 AND -69 TEST BOX SIMILAR

(A)

**Engine N1 and N2 Interface Equipment
Figure 1 (Sheet 3 of 4)**

ILLUSTRATED TOOL AND EQUIPMENT MANUAL

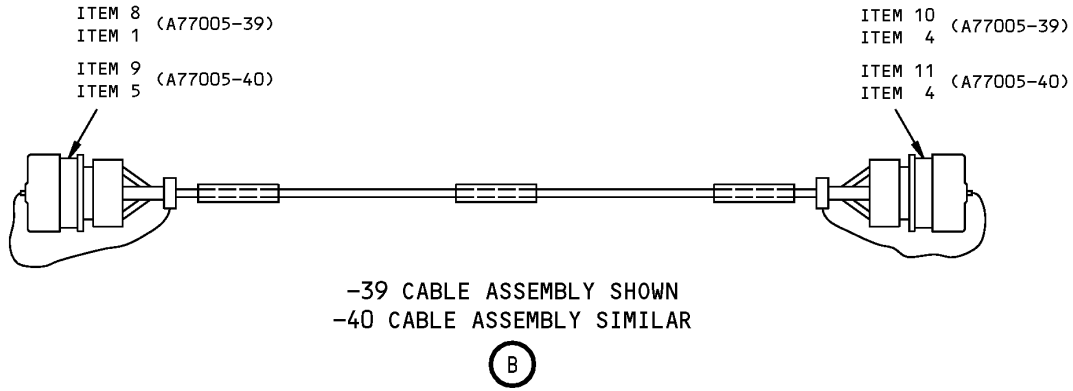

Engine N1 and N2 Interface Equipment
Figure 1 (Sheet 4 of 4)

REPAIRABLE/REPLACEABLE PARTS			
ITEM NO.	PART NO.	NOMENCLATURE	VENDOR CODE
1	M83723/60-114AC	DUST CAP	
2	M83723/83R147N	CONNECTOR	
3	M83723/90Y105N	CONNECTOR	
4	M83723/60-110AC	DUST CAP	
5	M83723/60-116AC	DUST CAP	
6	M83723/83R1610N	CONNECTOR	
7	M83723/90Y1059	CONNECTOR	
8	M83723/86R147N	CONNECTOR	
9	M83723/86R1610N	CONNECTOR	
10	M83723/90Y105N	CONNECTOR	
11	M83723/90Y1059	CONNECTOR	

767
ILLUSTRATED TOOL AND EQUIPMENT MANUAL

PART NUMBER: A77003-18

NAME: TEST EQUIPMENT - INDICATING SYSTEM, EXHAUST GAS TEMPERATURE (EGT)

AIRPLANE MAINTENANCE: YES

COMPONENT MAINTENANCE: NO

USAGE & DESCRIPTION: The A77003-18 test equipment is used on 767 airplanes equipped with JT9D-7R4D and JT9D-7R4E engines. A77003 is used to test the exhaust gas temperature (EGT) indicating system. Refer to AMM 77-21-00 for complete usage instructions. A77003-18 consists of an A77003-29 test box assembly and an A77003-36 adapter cable assembly, both contained in a storage box.

WEIGHT: 3 lbs (1.4 kg)

DIMENSIONS: 12 x 12 x 6 inches (305 x 305 x 152 mm)

NOTE: A77003-18 supersedes A77003-15.

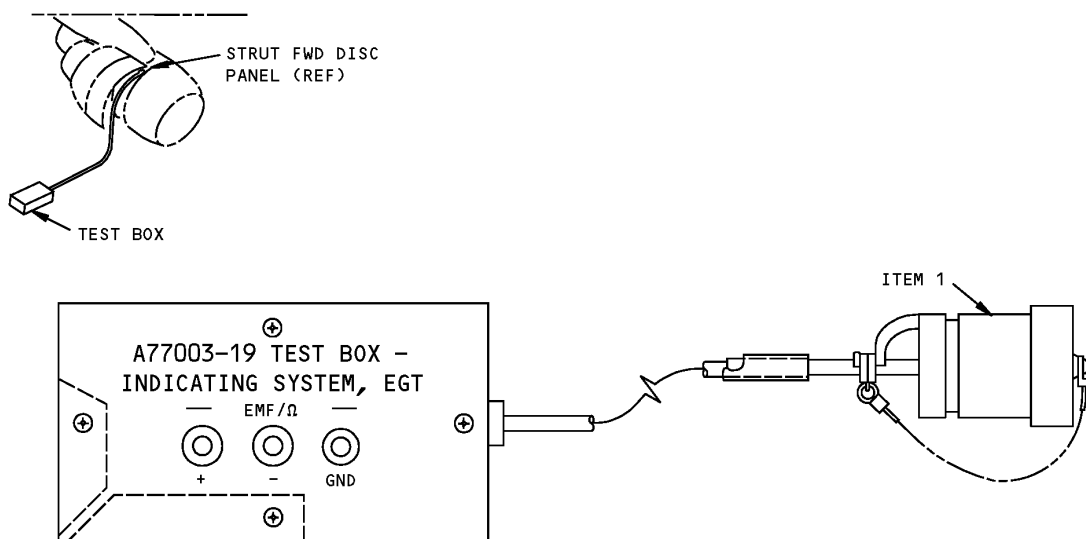

Exhaust Gas Temperature Indicating System Test Equipment
Figure 1

REPAIRABLE/REPLACEABLE PARTS			
ITEM NO.	PART NO.	NOMENCLATURE	VENDOR CODE
1	ZZY-R-1028-42P	CONNECTOR	3G791

ILLUSTRATED TOOL AND EQUIPMENT MANUAL

PART NUMBER: A77001-1**NAME:** TEST BOX - ELECTRONIC ENGINE CONTROL MONITOR POWER SUPPLY**AIRPLANE MAINTENANCE:** NO**COMPONENT MAINTENANCE:** YES**USAGE & DESCRIPTION:** The A77001 drawing has been transferred to BAE Systems and will no longer be revised by Boeing. The A77001 inclusion in the 767 ITEM is for information and historical purposes only.

The A77001-1 test box is used during component maintenance on 767-200, -200ER and -300 airplanes. A77001 is used to functionally test the circuitry and continuity of the electronic engine control monitor (EECM) module assembly. Refer to CMM 77-35-06 for complete usage instructions. A77001 consists of a test box and test cable.

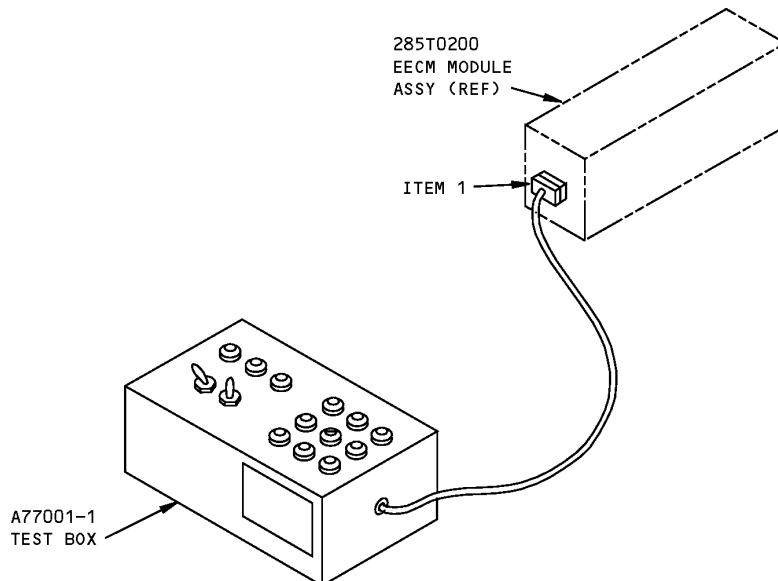
WEIGHT: 2 lbs (0.9 kg)**DIMENSIONS:** 3 X 6 X 8 inches (76 X 152 X 203 mm)

**Electronic Engine Control Monitor Power Supply Test Box
Figure 1**



767

ILLUSTRATED TOOL AND EQUIPMENT MANUAL

REPAIRABLE/REPLACEABLE PARTS			
ITEM NO.	PART NO.	NOMENCLATURE	VENDOR CODE
1	DAMA-15S	CONNECTOR	V71468

ILLUSTRATED TOOL AND EQUIPMENT MANUAL

PART NUMBER: A77002-1

NAME: TEST BOX - DISPLAY BOARD, ELECTRONIC ENGINE CONTROL MONITOR

AIRPLANE MAINTENANCE: NO

COMPONENT MAINTENANCE: YES

USAGE & DESCRIPTION: The A77002 drawing has been transferred to BAE Systems and will no longer be revised by Boeing. The A77002 inclusion in the 767 ITEM is for information and historical purposes only.

The A77002-1 test box is used on all 767 airplanes during component maintenance. A77002 is used to functionally test the character displays on the engine control monitor display board. Refer to CMM 77-35-05 for complete usage instructions. The test box consists of a printed circuit assembly and panel with terminals, switches and a power on light.

WEIGHT: 8 lbs (3.6 kg)

DIMENSIONS: 4 x 8 x 12 inches (102 x 203 x 305 mm)

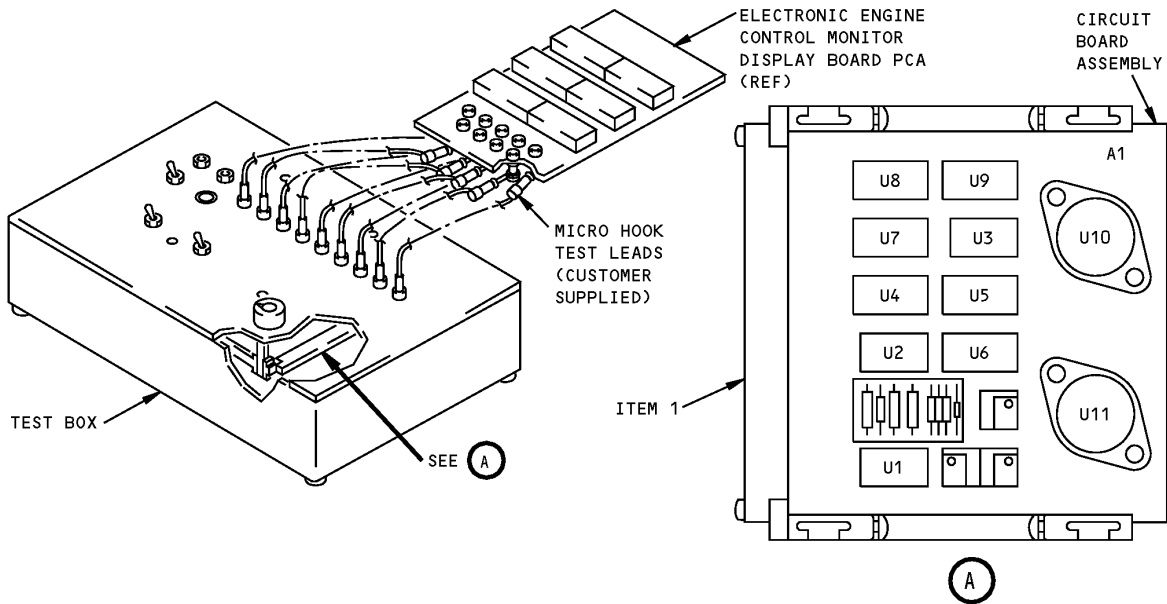

**Electronic Engine Control Monitor Display Board
Figure 1**



767

ILLUSTRATED TOOL AND EQUIPMENT MANUAL

REPAIRABLE/REPLACEABLE PARTS			
ITEM NO.	PART NO.	NOMENCLATURE	VENDOR CODE
1	R636-2	CONNECTOR	V82893

ILLUSTRATED TOOL AND EQUIPMENT MANUAL

PART NUMBER: C77004-10

NAME: TEST BOX - GENERIC AIRBORNE VIBRATION MONITOR (AVM) INTERFACE

AIRPLANE MAINTENANCE: YES

COMPONENT MAINTENANCE: NO

USAGE & DESCRIPTION: The C77004-10 test box is used on all 767 airplanes. C77004 provides an interface between a customer furnished ARINC 429 transmitter/receiver during troubleshooting of the generic airborne vibration monitor. See the current C77004 drawing, AMM 77-31-00 and FIM 77-31-00 for complete usage instructions. C77004-10 consists of a C77004-11 test box assembly and a C77004-6 box assembly.

WEIGHT: 3 lbs (1.4 kg)

DIMENSIONS: 2 x 5 x 8 inches (51 x 127 x 203 mm)

NOTE: C77004-10 supersedes C77004-1.

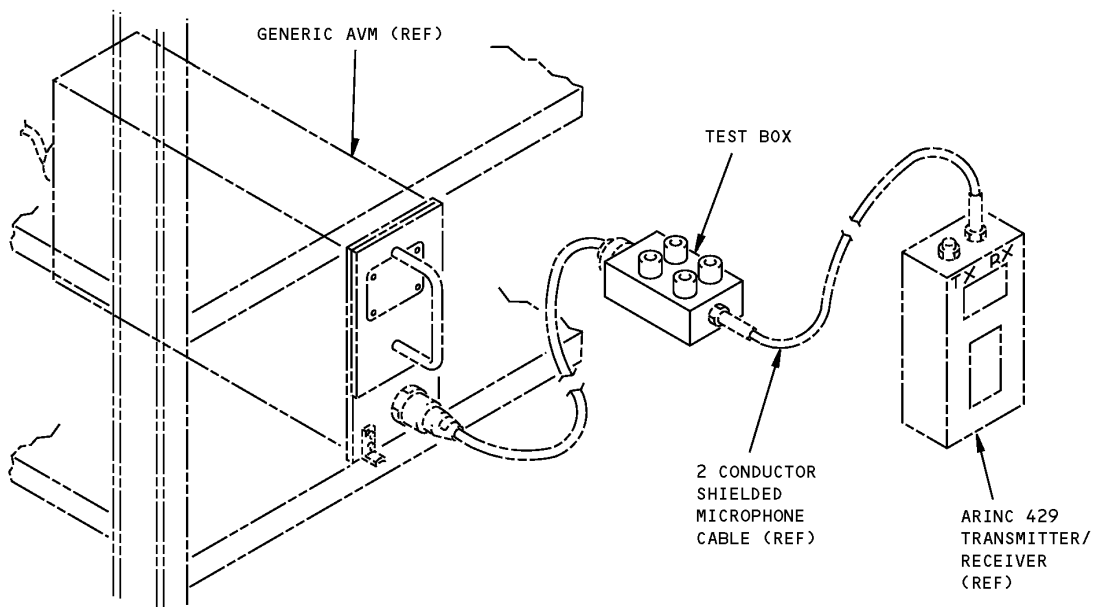

**Generic AVM Interface Test Box
Figure 1**