

CHAPTER

80

STARTING



767
ILLUSTRATED TOOL AND EQUIPMENT MANUAL

CHAPTER 80
STARTING

Subject/Page	Date	Subject/Page	Date	Subject/Page	Date
EFFECTIVE PAGES					
1	Apr 10/2008				
2	BLANK				
80-CONTENTS					
1	Apr 10/2006				
2	BLANK				
80-10-01					
1	Apr 10/2006				
2	Apr 10/2006				

A = Added, R = Revised, O = Overflow, D = Deleted

80-EFFECTIVE PAGES

Page 1
Apr 10/2008

D634T501



767

ILLUSTRATED TOOL AND EQUIPMENT MANUAL

TABLE OF CONTENTS

<u>Subject</u>	<u>Title</u>	<u>Part No.</u>
80-	STARTING	
80-10-01	DRIVE EXTENSION - STARTER VALVE AND PRESSURE REGULATING AND SHUTOFF VALVE (PRSOV)	G71021-16

80-CONTENTS

ILLUSTRATED TOOL AND EQUIPMENT MANUAL

PART NUMBER: G71021-16

NAME: DRIVE EXTENSION - STARTER VALVE AND PRESSURE REGULATING AND SHUTOFF VALVE (PRSOV)

AIRPLANE MAINTENANCE: YES

COMPONENT MAINTENANCE: NO

USAGE & DESCRIPTION: The G71021-16 drive extension is used on 767 airplanes equipped with PW4000, JT9D and CF6-80C2B engines. G71021 is used to manually operate the pressure regulating and shut off valve (PRSOV) and the starter valve on all PW4000, JT9D and CF6-80C2B engines by using a combination of 8 inch and 36 inch long extensions. Refer to AMM 36-11-04 and 71-00-00 for further usage instructions. G71021-1 consists of an 8 inch and 36 inch long extension bars and a storage box assembly.

WEIGHT: 7 lbs (3 kg)

DIMENSIONS: 2 x 2 x 37 inches (51 x 51 x 940 mm)

NOTE: G71021-16 supersedes G71021-1, -6 and -11.

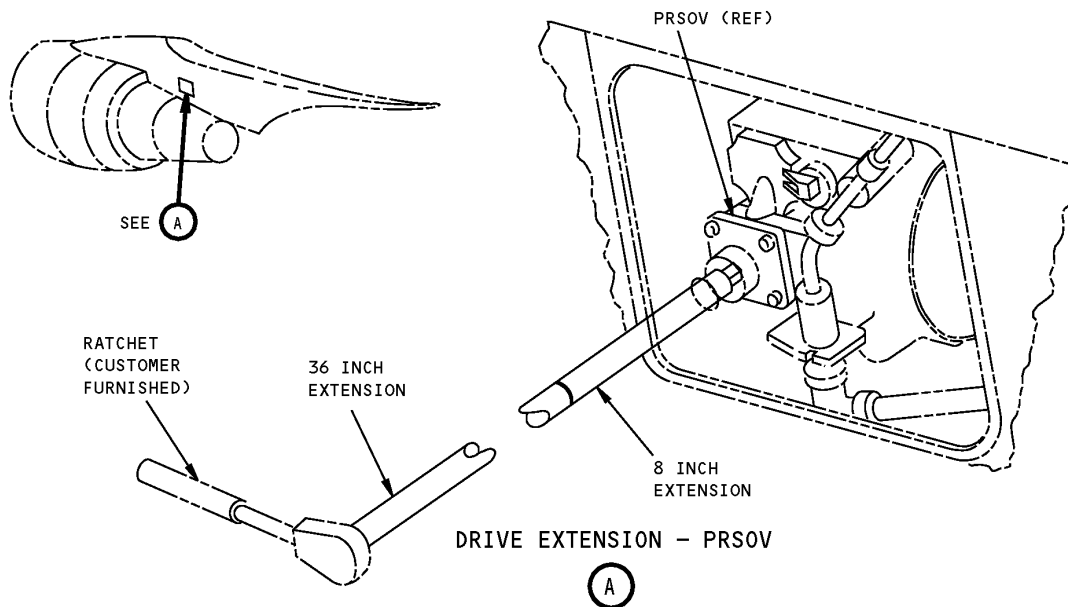

**Starter Valve and PRSOV Drive Extension
Figure 1 (Sheet 1 of 2)**

ILLUSTRATED TOOL AND EQUIPMENT MANUAL

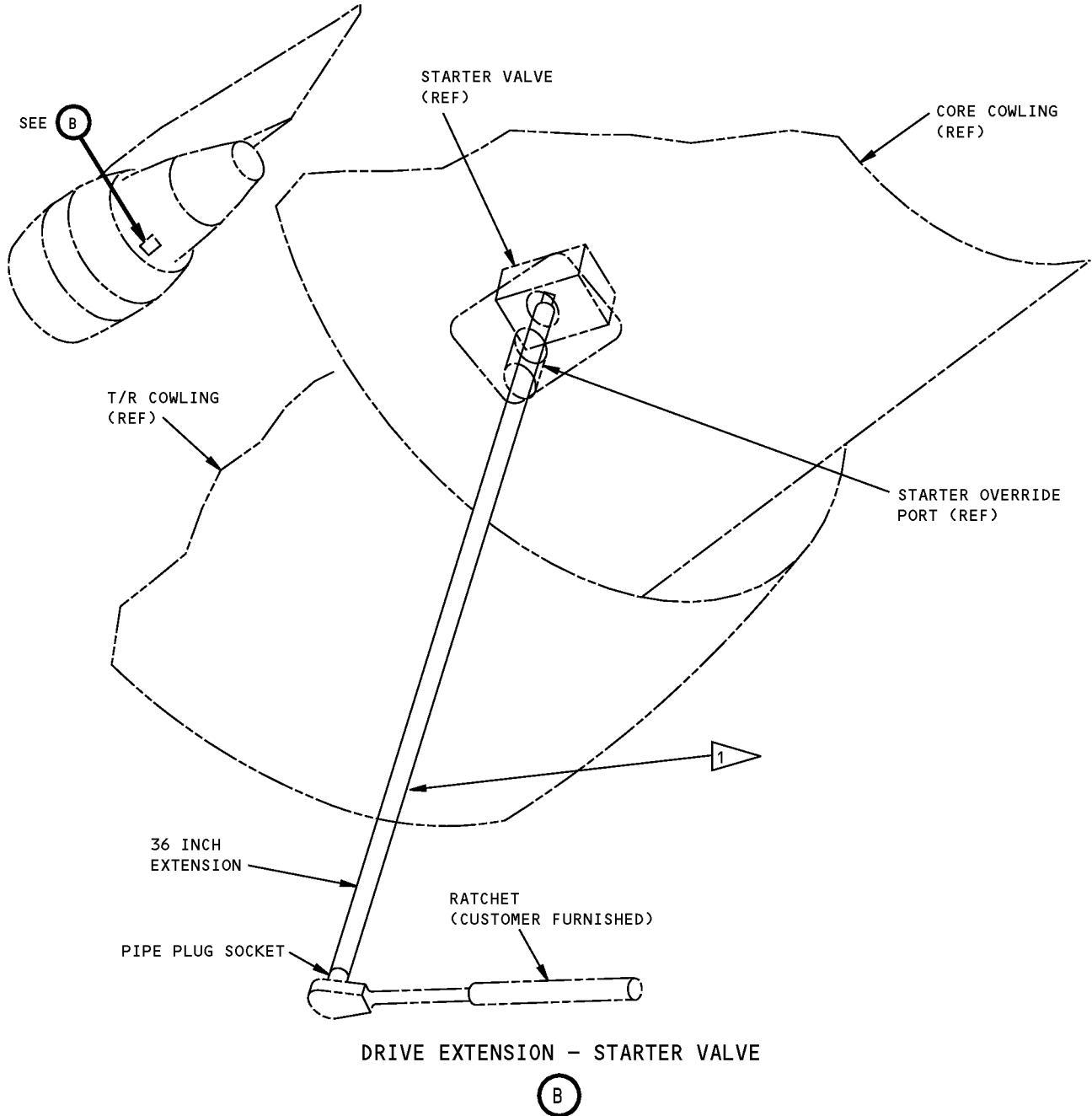

NOTE: CF6-80C2B STARTER VALVE IS LOCATED AT NACELLE BUTTOCK LINE O.O.

1 THE 747 INBOARD CF6-80C2B USE THE 36 INCH EXTENSION ONLY. THE 747 OUTBOARD CF6-80C2B ENGINE COMBINE THE 8 INCH AND THE 36 INCH EXTENSIONS. ON THE 747 PW4000, THE JT9D ENGINES AND ON THE 767, COMBINE THE 8 INCH AND 36 INCH EXTENSIONS.

**Starter Valve and PRSOV Drive Extension
Figure 1 (Sheet 2 of 2)**