

## OIL FILTER BYPASS WARNING SYSTEM

HXL  
DEC 22/06

79-35-00  
SECTION TITLE  
PAGE 1

**BOEING**  
767  
PARTS CATALOG (MAINTENANCE)

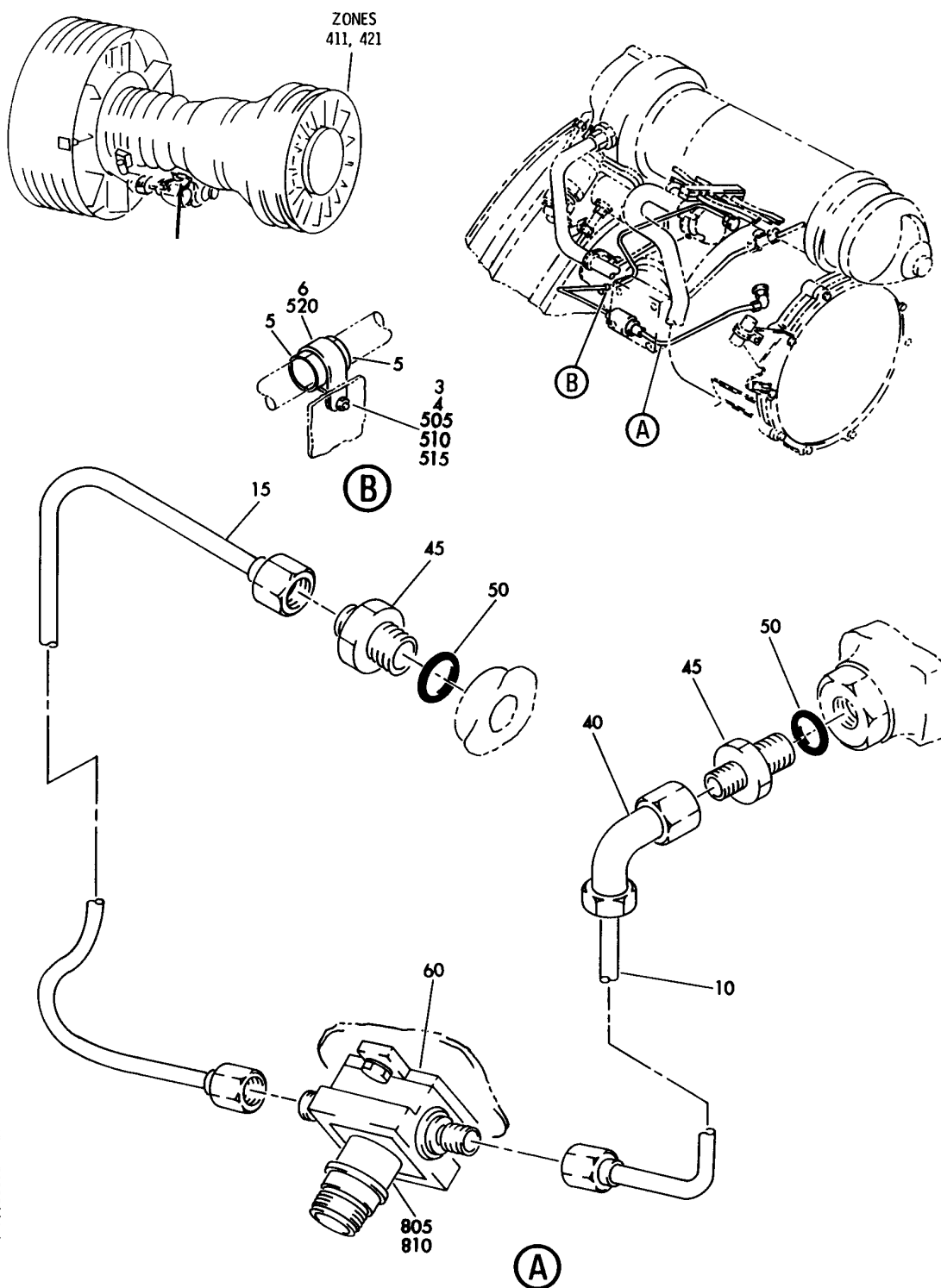

V 79350102 REV 140

SWITCH AND WIRING INSTL-OIL FILTER DIFFERENTIAL PRESSURE  
FIGURE 2

**79-35-01-02**

HXL  
DEC 22/06

79-35-01-02  
PAGE 0



767

PARTS CATALOG (MAINTENANCE)

FIG ITEM	PART NUMBER	1 2 3 4 5 6 7	NOMENCLATURE	EFFECT FROM TO	UNITS PER ASSY
2			SWITCH AND WIRING INSTL- OIL FILTER DIFFERENTIAL PRESSURE		
- 1	332T4453-1		SWITCH INSTL-OIL FILTER DIFFERENTIAL PRESSURE FOR NHA SEE: 71-00-51-02		RF
3	NAS1802-3		.SCREW-		1
4	PLH53C		.NUT SUPPLIER CODE: V62554 SPECIFICATION NUMBER: BACN10YR3C OPTIONAL PART: H52732-3C V15653		1
5	BACC10GT2-04		.CLAMP SHELL		2
6	S500-4		.CLAMP SUPPLIER CODE: V18076 SPECIFICATION NUMBER: BACC10HS04 OPTIONAL PART: 025029-04 V84971 44LC17H4PB V22175 490-04RPB V83930		1
10	332T4453-3		.TUBE ASSY- TUBING MATERIAL: 0.250 IN. OD 0.016 IN. WALL 7.5 IN. LG 21-6-9 BMS7-185 F-25.01 CRES		1
15	332T4453-4		.TUBE ASSY- TUBING MATERIAL: 0.250 IN. OD 0.016 IN. WALL 15.0 IN. LG 21-6-9 BMS7-185 F-25.01 CRES		1

ILLUSTRATION ITEMS NOT ON PARTS LIST ARE NOT APPLICABLE

- ITEM NOT ILLUSTRATED

HXL

79-35-01-02

BOEING PROPRIETARY - Copyright © - Unpublished Work - See title page for details.

79-35-01  
FIG. 02  
PAGE 1  
DEC 22/07

 **BOEING**  
767  
**PARTS CATALOG (MAINTENANCE)**

FIG ITEM	PART NUMBER	1 2 3 4 5 6 7	NOMENCLATURE	EFFECT FROM TO	UNITS PER ASSY
2					
- 20	AP2097H04		.. SLEEVE SUPPLIER CODE: V01673 SPECIFICATION NUMBER: BACS13BX04H OPTIONAL PART: 2-02903-04H V11328 35235V04 V08199 AFP175V04 V30974 DBOS13BX04H V14798		2
- 25	MS21921-4J		.. NUT		2
40	NAS1762J0404		. ELBOW		1
45	MS21916J6-4		. REDUCER		2
50	M83248-1-906		. PACKING		2
60	59T695		. SWITCH- SUPPLIER CODE: V77445 ATTACHING PARTS		1
- 65	NAS1802-3-10		. SCREW		3
- 70	AN960C10L		. WASHER		3
- 75	BRH10C3M		. NUT- SUPPLIER CODE: V52828 SPECIFICATION NUMBER: BACN10JC3CM OPTIONAL PART: T6C1032JM V11815 97E02 V80539 109LH9075-3W V72962 VN303D02 V92215 NS202101SE02 V80539 H01-3BAC V15653 BACN10YR3CM BACN10YR3C		3
ILLUSTRATION ITEMS NOT ON PARTS LIST ARE NOT APPLICABLE					

- ITEM NOT ILLUSTRATED

HXL

# 79-35-01-02

BOEING PROPRIETARY - Copyright © - Unpublished Work - See title page for details.

79-35-01  
FIG. 02  
PAGE 2  
DEC 22/07



767

PARTS CATALOG (MAINTENANCE)

FIG ITEM	PART NUMBER	1 2 3 4 5 6 7	NOMENCLATURE	EFFECT FROM TO	UNITS PER ASSY
2					
- 75	PLH53CM		.NUT- SUPPLIER CODE: VF0224 SPECIFICATION NUMBER: BACN10YR3CM OPTIONAL PART: H52732-3CM V15653 BACN10JC3CM BACN10YR3C		3
- 75	PLH53C		.NUT- SUPPLIER CODE: V62554 SPECIFICATION NUMBER: BACN10YR3C OPTIONAL PART: H52732-3C V15653 BACN10JC3CM BACN10YR3CM		3
- 500	332T4240-6		-----*----- WIRING INSTL-ENGINE BUILD-UP (OIL FILTER DIFFERENTIAL PRESSURE SWITCH ONLY) VARIABLE DRAWING REF: 332T4240-5007 FOR NHA/OTHER SYS DET SEE: 71-00-51-02		RF
505	NAS1802-3		.SCREW- SIZE DETERMINED ON INSTL.		1
510	AN960C10L		.WASHER		1
515	PLH53C		.NUT- SUPPLIER CODE: V62554 SPECIFICATION NUMBER: BACN10YR3C OPTIONAL PART: H52732-3C V15653 BACN10JC3CM BACN10YR3CM BACN10JC3C		1

ILLUSTRATION ITEMS NOT ON PARTS LIST ARE NOT APPLICABLE

- ITEM NOT ILLUSTRATED

HXL

79-35-01-02

BOEING PROPRIETARY - Copyright © - Unpublished Work - See title page for details.

79-35-01  
FIG. 02  
PAGE 3  
DEC 22/08



767

PARTS CATALOG (MAINTENANCE)

FIG ITEM	PART NUMBER	1 2 3 4 5 6 7	NOMENCLATURE	EFFECT FROM TO	UNITS PER ASSY
2 515	BRH10C3		.NUT- SUPPLIER CODE: V52828 SPECIFICATION NUMBER: BACN10JC3C OPTIONAL PART: T6C1032J V11815 97-02 V80539 101LH9075-3W V72962 VN303B02 V92215 NS202101S02 V80539 H31-3BAC V15653 BACN10JC3CM BACN10YR3CM BACN10YR3C		1
515	BRH10C3M		.NUT- SUPPLIER CODE: V52828 SPECIFICATION NUMBER: BACN10JC3CM OPTIONAL PART: T6C1032JM V11815 97E02 V80539 109LH9075-3W V72962 VN303D02 V92215 NS202101SE02 V80539 H01-3BAC V15653 BACN10JC3C BACN10YR3CM BACN10YR3C		1

ILLUSTRATION ITEMS NOT ON PARTS LIST ARE NOT APPLICABLE

- ITEM NOT ILLUSTRATED

HXL

79-35-01-02

BOEING PROPRIETARY - Copyright © - Unpublished Work - See title page for details.

79-35-01  
FIG. 02  
PAGE 4  
DEC 22/06

 **BOEING**  
767  
**PARTS CATALOG (MAINTENANCE)**

FIG ITEM	PART NUMBER	1 2 3 4 5 6 7	NOMENCLATURE	EFFECT FROM TO	UNITS PER ASSY
2 515	PLH53CM		.NUT- SUPPLIER CODE: VF0224 SPECIFICATION NUMBER: BACN10YR3CM OPTIONAL PART: H52732-3CM V15653 BACN10JC3CM BACN10JC3C BACN10YR3C		1
520	BACC10GU		.CLAMP- SIZE DETERMINED ON INSTL.		1
- 800	286T3510-043		.WIRE BUNDLE ASSY		RF
805	G899314S		..CLAMP- SUPPLIER CODE: V06324 SPECIFICATION NUMBER: BACC10HD14A OPTIONAL PART: G8993M14S V06324 S2251-14-30S V07418 6000-123-01 V14283 900-555F14-10 V31461 ELECTRICAL EQUIP NUMBER: D10974T WIRING DIAGRAM REF: 793511		1
810	R071014B7S7L		..CONNECTOR- SUPPLIER CODE: V41118 SPECIFICATION NUMBER: BACC63BP14B7S7L ELECTRICAL EQUIP NUMBER: D10974 WIRING DIAGRAM REF: 793511		1

ILLUSTRATION ITEMS NOT ON PARTS LIST ARE NOT APPLICABLE

- ITEM NOT ILLUSTRATED

HXL

# 79-35-01-02

BOEING PROPRIETARY - Copyright © - Unpublished Work - See title page for details.

79-35-01  
FIG. 02  
PAGE 5  
DEC 22/08