



BOEING
767
FAULT ISOLATION/MAINT MANUAL

Scandinavian Airlines System

PAGE	DATE	CODE	PAGE	DATE	CODE	PAGE	DATE	CODE
CHAPTER 33 TAB			33-FAULT CODE DIAGRAM			33-11-00		
LIGHTS			CONT.			101 FEB 10/94 01		
EFFECTIVE PAGES			19	AUG 10/98	22	102	FEB 10/94	01
SEE LAST PAGE OF LIST FOR			20	AUG 10/98	15	103	FEB 10/94	01
NUMBER OF PAGES			21	AUG 10/98	08	104	FEB 10/94	01
33-CONTENTS			22	AUG 10/98	06	105	FEB 10/94	01
1	AUG 22/06	SAS	23	AUG 10/98	06	106	FEB 10/94	01
2	APR 22/06	SAS	24	AUG 10/98	09	107	FEB 10/94	01
3	APR 22/00	SAS	25	AUG 10/98	06	108	NOV 10/94	01
4	DEC 22/99	SAS	26	AUG 10/98	11	109	DEC 22/06	01
5	DEC 22/99	SAS	27	AUG 10/98	10	110	NOV 10/94	01
6	DEC 22/99	SAS	28	MAY 10/88	02	111	FEB 10/94	01
7	DEC 22/99	SAS	29	MAY 10/88	02	112	BLANK	
8	BLANK		30	AUG 10/98	09	33-13-00		
33-HOW TO USE THE FIM			31	AUG 10/98	09	101	FEB 10/94	01
1	AUG 22/99	01	32	AUG 10/98	01	102	AUG 10/95	01
2	AUG 22/99	01	33	AUG 10/98	10	103	FEB 10/94	01
3	AUG 22/99	01	34	AUG 10/98	09	104	FEB 10/94	01
4	AUG 22/99	01	33-FAULT CODE INDEX			105	FEB 10/94	01
5	AUG 22/99	01	1	MAY 10/96	10	106	NOV 10/95	01
6	AUG 22/99	01	2	MAY 10/96	19	107	FEB 10/94	02
33-INDEX			3	AUG 10/96	30	108	FEB 10/94	02
1	NOV 10/95	13	4	MAY 10/96	22	109	NOV 10/95	02
2	NOV 10/90	01	5	MAY 10/96	20	110	AUG 22/01	02
3	NOV 10/90	10	6	MAY 10/96	18	33-14-00		
4	NOV 10/95	36	7	MAY 10/96	16	101	MAY 10/94	01
33-EICAS MESSAGES			8	MAY 10/96	03	102	AUG 10/95	01
1	NOV 10/90	01	9	MAY 10/96	03	103	MAY 10/94	01
2	NOV 10/90	01	10	MAY 10/96	07	104	MAY 10/94	01
3	NOV 10/90	01	11	MAY 10/96	13	105	MAY 10/94	01
4	BLANK		12	MAY 10/96	05	106	FEB 10/94	03
33-FAULT CODE DIAGRAM			13	MAY 10/97	20	33-16-00		
1	NOV 01/84	01	14	MAY 10/96	20	101	FEB 10/94	01
2	MAY 01/86	03	15	APR 22/01	20	102	FEB 10/94	01
3	FEB 10/96	01	16	AUG 10/96	29	103	FEB 10/94	01
4	AUG 10/96	04	17	MAY 10/96	27	104	NOV 10/95	01
5	AUG 10/87	03	18	APR 22/01	26	105	FEB 10/94	03
6	FEB 01/86	05	19	APR 22/01	24	106	NOV 10/95	01
7	NOV 10/95	01	20	MAY 10/96	24	107	APR 22/99	14
8	AUG 01/82	01	21	MAY 10/96	23	108	FEB 10/94	01
9	NOV 10/95	02	22	MAY 10/96	26	33-21-00		
10	NOV 01/85	02	23	MAY 10/96	28	101	NOV 10/95	01
11	NOV 10/95	01	24	MAY 10/96	27	102	NOV 10/94	01
12	NOV 10/95	01	25	DEC 22/01	24	103	NOV 10/94	01
13	AUG 10/98	01	26	DEC 22/01	16	104	NOV 10/94	01
14	AUG 10/98	08	27	DEC 22/01	21	105	NOV 10/94	01
15	AUG 10/98	02	28	DEC 22/01	15	106	APR 22/99	01
16	AUG 10/98	19	29	DEC 22/01	09	107	NOV 10/94	01
17	AUG 10/98	01	30	APR 22/01	06	108	NOV 10/94	01
18	AUG 10/98	01	31	MAY 10/96	04	109	MAY 10/95	01
			32	MAY 10/96	02	110	BLANK	
			33-BITE INDEX					
			1	AUG 22/99	01			
			2	AUG 22/99	01			
			3	AUG 22/99	01			
			4	BLANK				

R = REVISED, A = ADDED OR D = DELETED
 F = FOLDOUT PAGE
 33
 AUG 22/09

D633T633

CHAPTER 33
 EFFECTIVE PAGES
 PAGE 1
 CONTINUED



BOEING
767
FAULT ISOLATION/MAINT MANUAL

Scandinavian Airlines System

PAGE	DATE	CODE	PAGE	DATE	CODE	PAGE	DATE	CODE
33-22-00			33-31-00		CONT.	33-51-00		CONT.
101	NOV 10/95	01	117	MAY 10/94	02	105	MAY 10/94	01
102	NOV 10/94	01	118	MAY 10/94	02	106	NOV 10/95	06
103	NOV 10/94	01	119	MAY 10/94	02	107	DEC 22/05	10
104	DEC 22/99	02	120	AUG 10/98	02	108	DEC 22/05	05
105	DEC 22/99	02	121	NOV 10/95	01	109	FEB 10/95	01
106	DEC 22/99	02	122	BLANK		110	BLANK	
107	DEC 22/99	02						
108	DEC 22/99	02	33-37-00					
109	DEC 22/99	02	101	MAY 10/94	01			
110	DEC 22/99	02	102	MAY 10/94	01			
			103	MAY 10/94	01			
33-24-00			104	MAY 10/94	01			
101	FEB 10/94	01	105	MAY 10/94	01			
102	FEB 10/94	01	106	DEC 22/99	01			
103	FEB 10/94	01	107	DEC 22/99	01			
104	APR 22/06	01	108	DEC 22/99	01			
105	APR 22/06	01	109	DEC 22/99	01			
106	APR 22/06	01	110	DEC 22/99	01			
107	NOV 10/95	01	111	DEC 22/99	01			
108	APR 22/06	01	112	BLANK				
33-25-00			33-41-00					
101	NOV 10/95	01	101	NOV 10/94	01			
102	NOV 10/95	01	102	MAY 10/95	01			
103	AUG 10/93	01						
104	AUG 10/93	01	33-42-00					
			101	MAY 10/94	01			
33-26-00			102	MAY 10/94	01			
101	APR 10/98	01	103	NOV 10/94	01			
102	FEB 10/94	01	104	DEC 22/99	01			
103	AUG 10/94	01	105	DEC 22/06	01			
104	APR 10/98	01	106	DEC 22/99	01			
105	AUG 10/95	01	107	DEC 22/99	03			
106	BLANK		108	DEC 22/99	03			
33-27-00			33-43-00					
101	FEB 10/94	01	101	MAY 10/94	01			
102	FEB 10/94	01	102	MAY 10/94	01			
103	NOV 10/95	01	103	MAY 10/94	01			
104	BLANK		104	BLANK				
33-31-00			33-44-00					
101	NOV 10/95	01	101	NOV 10/96	03			
102	MAY 10/95	01	102	DEC 22/99	01			
103	MAY 10/94	01	103	DEC 22/99	02			
104	MAY 10/94	01	104	BLANK				
105	MAY 10/94	01						
106	MAY 10/94	01	33-45-00					
107	MAY 10/94	01	101	MAY 10/94	02			
108	MAY 10/95	01	102	MAY 10/95	02			
109	NOV 10/95	01	103	APR 22/01	02			
110	AUG 10/95	01	104	BLANK				
111	MAY 10/94	01						
112	MAY 10/94	01	33-51-00					
113	MAY 10/94	01	101	MAY 10/94	05			
114	MAY 10/94	01	102	MAY 10/94	01			
115	MAY 10/94	01	103	MAY 10/94	01			
116	MAY 10/94	01	104	AUG 10/98	06			

R = REVISED, A = ADDED OR D = DELETED

F = FOLDOUT PAGE

33

AUG 22/09

D633T633

CHAPTER 33
EFFECTIVE PAGES
PAGE 2
LAST PAGE



767

FAULT ISOLATION/MAINT MANUAL

CHAPTER 33 - LIGHTS

TABLE OF CONTENTS

<u>Subject</u>	Chapter Section <u>Subject</u>	<u>Page</u>	<u>Effectivity</u>
HOW TO USE THE FIM	33-HOW TO USE THE FIM	1	ALL
INDEX	33-INDEX	1	ALL
EICAS MESSAGES	33-EICAS MESSAGES	1	ALL
FAULT CODE DIAGRAMS	33-FAULT CODE DIAGRAM	1	ALL
FAULT CODE INDEX	33-FAULT CODE INDEX	1	ALL
BITE INDEX	33-BITE INDEX	1	ALL
<u>LIGHTS</u>	33-00-00		
<u>FLIGHT COMPARTMENT LIGHTS</u>	33-10-00		
FLIGHT COMPARTMENT ILLUMINATION	33-11-00		
Component Location		101	ALL
Component Index			
Component Location			
Fault Isolation			
Flight Compartment Dome Light Problems (Fig. 106)		108	
Flight Compartment Glareshield Floodlight Problems (Fig. 104)		106	
Flight Compartment Glareshield Floodlight Problems (Fig. 105)		107	
Flight Compartment Main Power Distribution Panel (P6) Floodlight Problems (Fig. 107)		111	
Flight Compartment Panel Floodlight Problems (Fig. 103)		104	

33-CONTENTS

SAS

Page 1
Aug 22/06



BOEING
767
FAULT ISOLATION/MAINT MANUAL

CHAPTER 33 - LIGHTS

TABLE OF CONTENTS

<u>Subject</u>	Chapter Section <u>Subject</u>	<u>Page</u>	<u>Effectivity</u>
INTEGRAL PANEL LIGHTS	33-13-00		
Component Location		101	ALL
Component Index			
Component Location			
Fault Isolation			
Flight Compartment - Aisle Stand/Overhead CB Panel Light Problems (Fig. 107)		109	
Flight Compartment - Captain's and Center Panel Light Problems (Fig. 103)		104	
Flight Compartment - First Officer's Panel Light Problems (Fig. 104)		105	
Flight Compartment - Glareshield Panel Light Problems (Fig. 106)		107	
Flight Compartment - Overhead Panel Light Problems (Fig. 105)		106	
Flight Compartment - Right Side Panel Light Problems (Fig. 108)		110	
FLIGHT COMPARTMENT MISCELLANEOUS LIGHTS	33-14-00		
Component Location		101	ALL
Component Index			
Component Location			
Fault Isolation			
Flight Compartment Chart Light Problems (Fig. 104)		105	
Flight Compartment Flt Kit/Utility/Note Pad Light Problems (Fig. 105)		106	
Flight Compartment Map Light Problems (Fig. 103)		104	
MASTER DIM AND TEST	33-16-00		
Component Location		101	ALL
Component Index			
Component Location			
Fault Isolation			
Flight Compartment Master Dim and Test Problems (Fig. 103)		104	

33-CONTENTS

SAS

Page 2
Apr 22/06



767
FAULT ISOLATION/MAINT MANUAL

CHAPTER 33 - LIGHTS

TABLE OF CONTENTS

<u>Subject</u>	<u>Chapter Section Subject</u>	<u>Page</u>	<u>Effectivity</u>
<u>PASSENGER COMPARTMENT LIGHTS</u>	33-20-00		
PASSENGER COMPARTMENT ILLUMINATION	33-21-00		
Component Location		101	ALL
Component Index			
Component Location			
Fault Isolation			
Indirect Ceiling Lights Problems (Fig. 104)		106	
Night Lights Problems (Fig. 105)		107	
Partition Washlights Problems (Fig. 107)		109	
Sidewall Washlights Problems (Fig. 106)		108	
PASSENGER LOADING LIGHTS	33-22-00		
Component Location		101	ALL
Component Index			
Component Location			
Fault Isolation			
Aft Direct Ceiling Lights Problems with CABIN Switch in HI (Fig. 108)		109	
Aft Direct Ceiling Lights Problems with CABIN Switch on P22 In The Second Position (Fig. 106)		107	
Aft Direct Ceiling Lights Problems with CABIN Switch In Third Position (Fig. 107)		108	
Aft Direct Ceiling Lights Problems With CABIN Switch In LO (Fig. 105)		106	
Attendant's Work Lights Problems (Fig. 104)		105	
Forward Direct Ceiling Lights Problems (Fig. 109)		110	
Threshold Entry Lights Problems (Fig. 103)		104	



BOEING
767
FAULT ISOLATION/MAINT MANUAL

CHAPTER 33 - LIGHTS

TABLE OF CONTENTS

<u>Subject</u>	Chapter Section <u>Subject</u>	<u>Page</u>	<u>Effectivity</u>
PASSENGER SIGNS	33-24-00		
Component Location		101	ALL
Component Index			
Component Location			
Fault Isolation			
No Smoking Lights Problems (Fig. 104)		104	
Seat Belts and Return To Seat Lights Problems (Fig. 105)		106	
CALL LIGHTS	33-25-00		
Component Location		101	ALL
Component Index			
Component Location			
Fault Isolation			
Cabin Chime Sounds Intermittently (Fig. 103A)		104	
Lavatory Call System Problems (Fig. 103)		103	
LAVATORY LIGHTS	33-26-00		
Component Location		101	ALL
Component Index			
Component Location			
Fault Isolation			
Lavatory Lights Problems (Fig. 103)		104	
GALLEY LIGHTS	33-27-00		
Component Location		101	ALL
Component Index			
Component Location			
Fault Isolation			
Galley Lights Problems (Fig. 103)		103	



767
FAULT ISOLATION/MAINT MANUAL

CHAPTER 33 - LIGHTS

TABLE OF CONTENTS

<u>Subject</u>	<u>Chapter Section Subject</u>	<u>Page</u>	<u>Effectivity</u>
<u>CARGO AND SERVICE COMPARTMENT LIGHTS</u>	33-30-00		
SERVICE LIGHTS	33-31-00		
Component Location		101	ALL
Component Index			
Component Location			
Fault Isolation			
APU Compartment Lights		114	
Problems (Fig. 107)			
Forward Cargo Door Exterior		120	
Lights Problems			
Forward Equipment Center		116	
Lights Problems (Fig. 109)			
Left Air Conditioning		113	
Compartment Lights Problems			
(Fig. 106)			
Main Equipment Center Lights		117	
Problems (Fig. 110)			
Main Gear Wheel Well Service		111	
Lights Problems (Fig. 104)			
Right Air Conditioning		112	
Compartment Lights Problems			
(Fig. 105)			
Tailcone Compartment Lights		115	
Problems (Fig. 108)			
LOWER LOBE CARGO COMPARTMENT	33-37-00		
LIGHTS			
Component Location		101	ALL
Component Index			
Component Location			
Fault Isolation			
Aft Cargo Compartment Light		109	
Problems (Fig. 105)			
Forward Cargo Compartment		107	
Light Problems (Fig. 104)			
Forward Cargo Compartment		106	
Lights OFF with Forward Cargo			
Access Door Open (Fig. 103)			



767

FAULT ISOLATION/MAINT MANUAL

CHAPTER 33 - LIGHTS

TABLE OF CONTENTS

<u>Subject</u>	Chapter Section <u>Subject</u>	<u>Page</u>	<u>Effectivity</u>
<u>EXTERIOR LIGHTS</u>	33-40-00		
WING ILLUMINATION LIGHTS	33-41-00		
Component Location		101	ALL
Component Index			
Component Location			
LANDING, RUNWAY TURNOFF AND TAXI LIGHTS	33-42-00		
Component Location		101	ALL
Component Index			
Component Location			
Fault Isolation			
Nose Gear Landing Light Problems (Fig. 105)		107	
Runway Turnoff Light Problems (Fig. 104)		106	
Taxi Light Problems (Fig. 103)		104	
Wing Landing Light Problems (Fig. 106)		108	
POSITION LIGHTS	33-43-00		
Component Location		101	ALL
Component Index			
Component Location			
ANTI-COLLISION LIGHTS	33-44-00		
Component Location		101	ALL
Component Index			
Component Location			
LOGO LIGHTS	33-45-00		
Component Location		101	ALL
Component Index			
Component Location			
Fault Isolation			
Logo Lights Problems (Fig. 103)		103	
<u>EMERGENCY LIGHTING</u>	33-50-00		
EMERGENCY LIGHTS	33-51-00		
Component Location		101	ALL
Component Index			
Component Location			
Fault Isolation			
Exterior Emergency Lights Problems (Fig. 104)		109	



767
FAULT ISOLATION/MAINT MANUAL

CHAPTER 33 - LIGHTS

TABLE OF CONTENTS

<u>Subject</u>	Chapter Section <u>Subject</u>	<u>Page</u>	<u>Effectivity</u>
Interior Emergency Lights Problems (Fig. 103)		107	

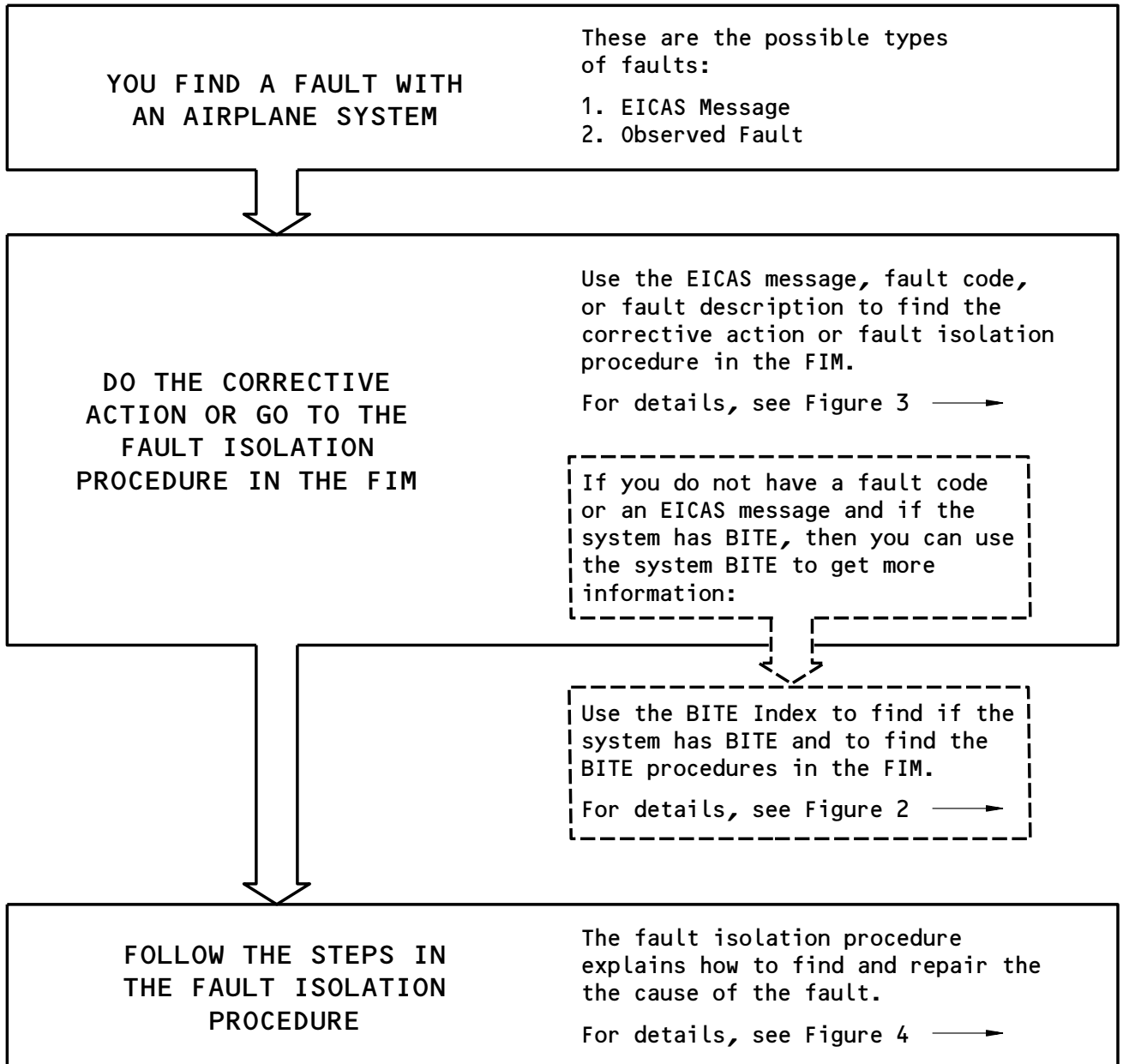

Basic Fault Isolation Process
Figure 1

EFFECTIVITY

ALL

33-HOW TO USE THE FIM

01

Page 1
Aug 22/99

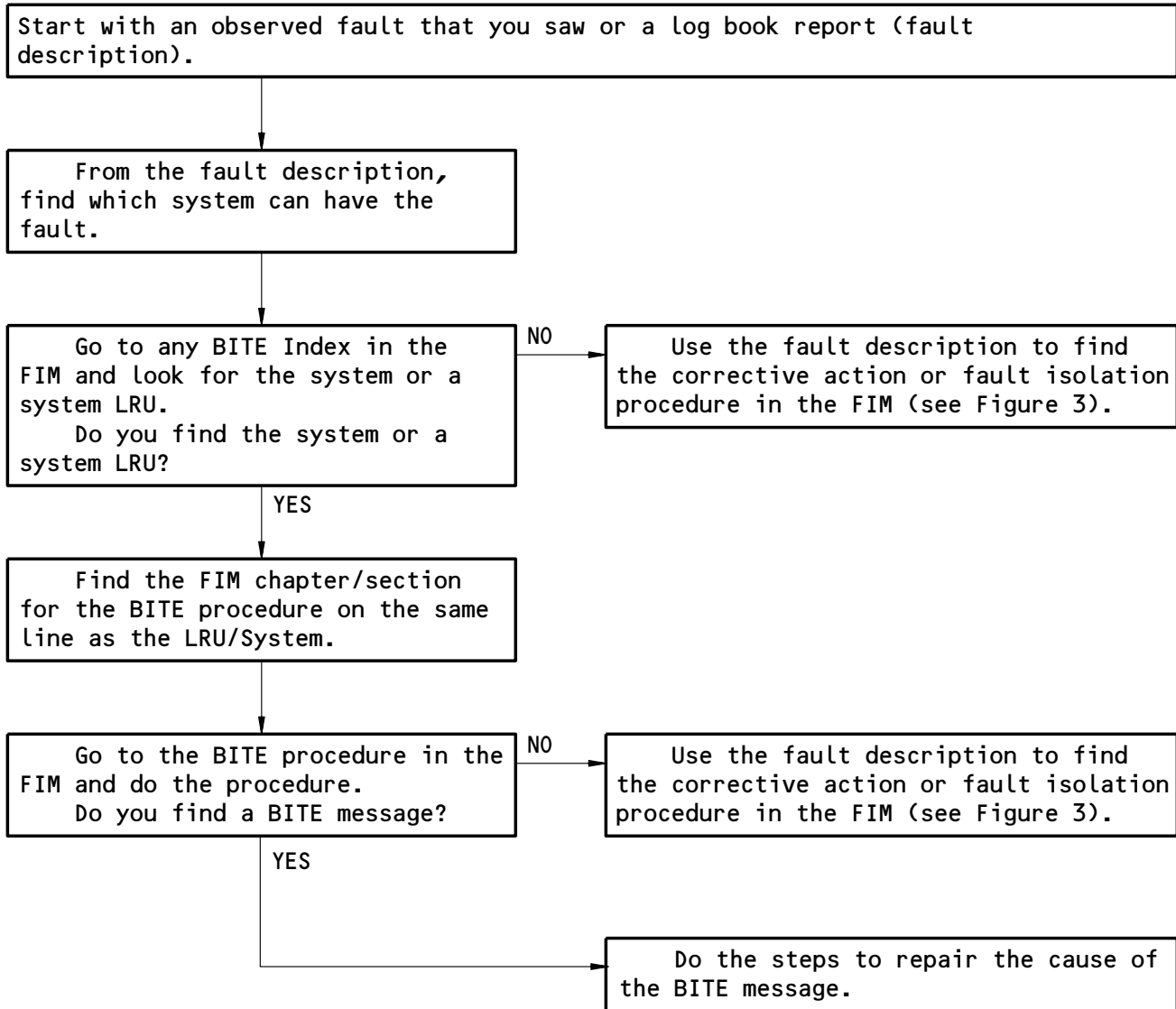

How to Get Fault Information from BITE
Figure 2

EFFECTIVITY

ALL

33-HOW TO USE THE FIM

01

Page 2
Aug 22/99

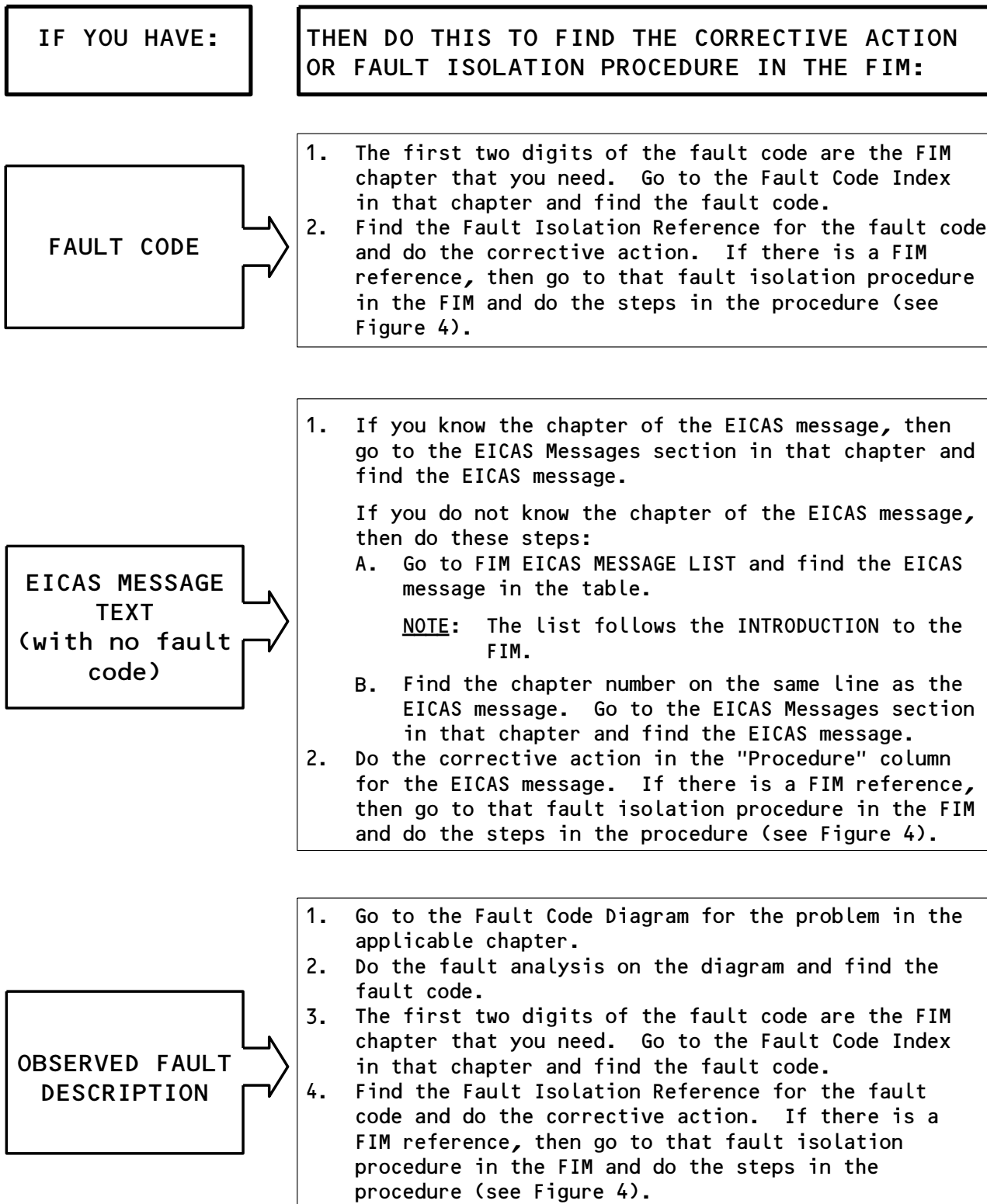

How to Find the Corrective Action or Fault Isolation Procedure in the FIM

Figure 3

EFFECTIVITY

ALL

33-HOW TO USE THE FIM

01

Page 3
Aug 22/99

ASSUMED CONDITIONS AT START OF TASK

- External electrical power is OFF
- Hydraulic power and pneumatic power are OFF
- Engines are shut down
- Circuit breakers for the system are closed
- No equipment in the system is deactivated

PREREQUISITES

- This box gives the steps to get the airplane from the normal shutdown condition to the configuration necessary to do the fault isolation procedure.
- The Prerequisites give procedure references, circuit breakers, and special tools and equipment requirements.

FAULT ISOLATION BLOCKS

- Start the fault isolation procedure at block 1 unless specified differently.
- Do the check to get an answer to the question in the box. Follow the arrow that applies to your answer. This will go to the next check.
- When you get to a box in the column at the right of the page, you have isolated that fault. Do the steps in that box to repair the cause of the fault.
- Make sure that fault is corrected to complete the procedure.

Do the Fault Isolation Procedure
Figure 4

EFFECTIVITY

ALL

33-HOW TO USE THE FIM

01

Page 4
Aug 22/99

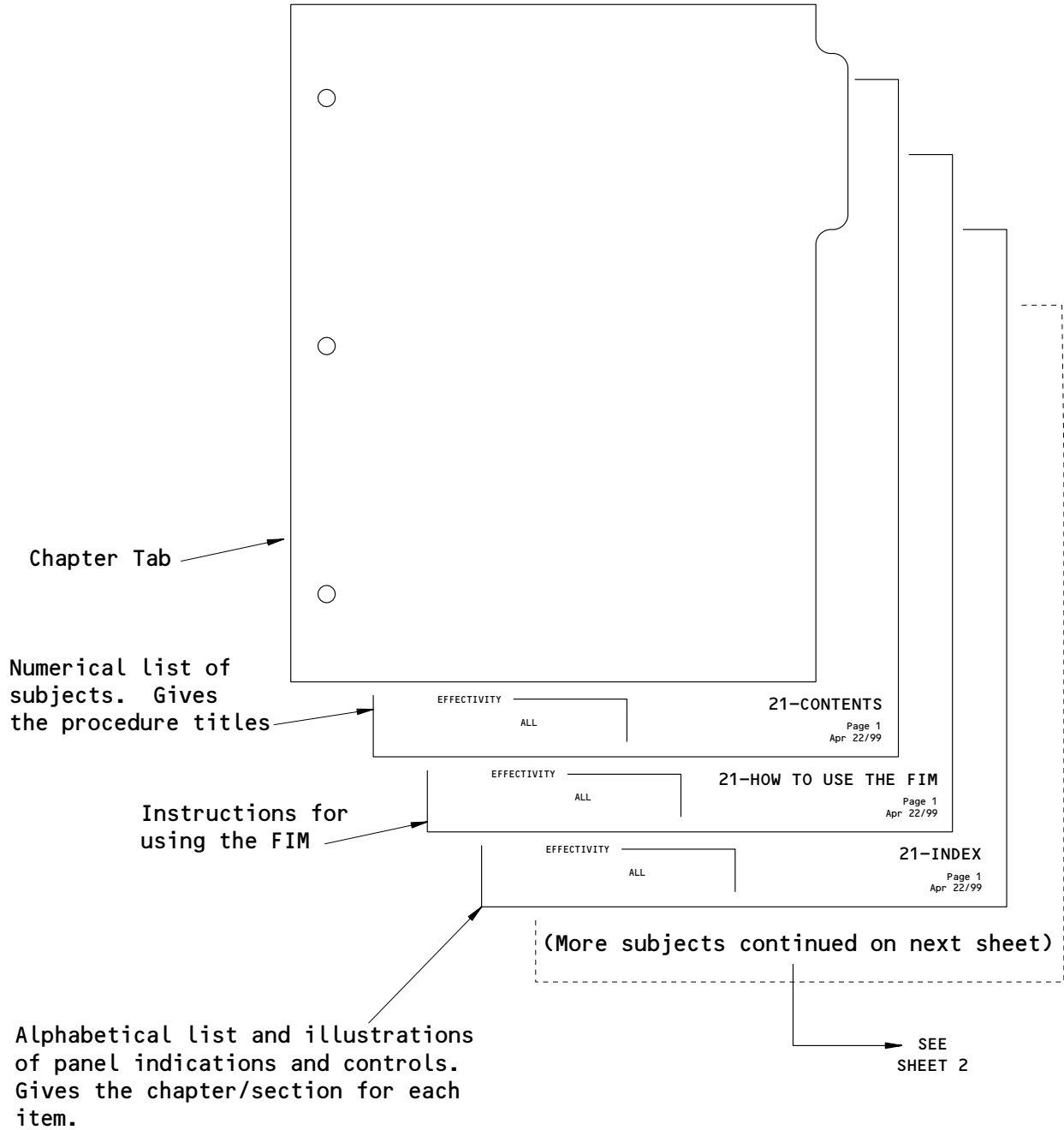

Subjects in Each FIM Chapter
Figure 5 (Sheet 1)

<p>EFFECTIVITY</p> <hr/> <p align="center">ALL</p>	<p align="center">33-HOW TO USE THE FIM</p> <p align="right">01 Page 5 Aug 22/99</p>
--	--

K37692

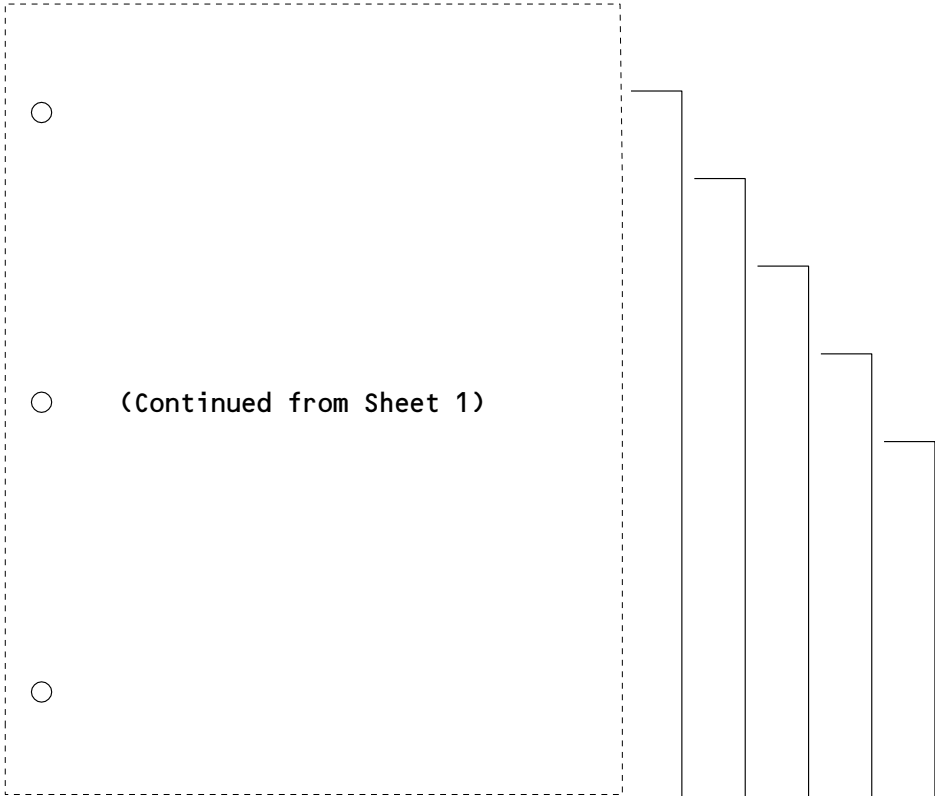

Alphabetical list of the EICAS messages. Gives the procedure to repair the cause of the message or a reference to a fault isolation procedure.

Failure analysis diagrams for the airplane systems to find the correct fault code for the fault.

Numerical list of fault codes. Gives the procedure to repair the cause of the fault or a reference to a fault isolation procedure.

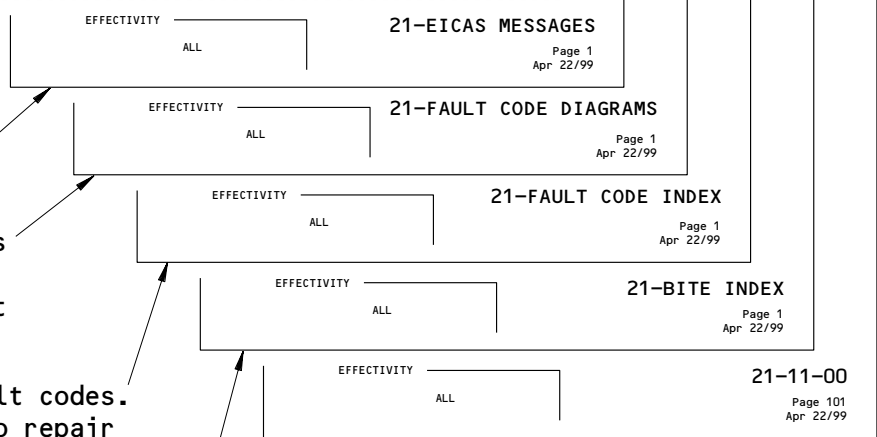

Alphabetical list of all the LRUs/systems that have BITE. Gives the chapter/section for the BITE procedure.

Component index, component location, and fault isolation procedures for the systems in the chapter.

Subjects in Each FIM Chapter
Figure 5 (Sheet 2)

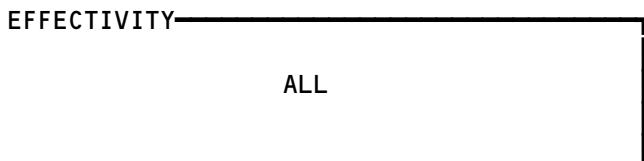

33-HOW TO USE THE FIM

<u>TITLE</u>	<u>CHAP/SEC</u>	<u>TITLE</u>	<u>CHAP/SEC</u>
--------------	-----------------	--------------	-----------------

EXTERIOR LIGHTS

ANTICOLLISION	3344
LANDING (NOSE)	3342
LANDING (WING)	3342
LOGO	3345
POSITION	3343
RUNWAY TURNOFF	3342
TAXI	3342
WHEEL WELL	3331
WING	3341

CABIN LIGHTS

CEILING	
DIRECT	3322
INDIRECT	3321
CLOSET	3322
EMER EXIT	3351
EMERGENCY (INTERIOR)	
(ATTND PNL SW)	3351
EMERGENCY (INTERIOR)	
(OVHD PNL SW)	3351
ENTRY	3322
EXIT	3351
FLOOR EMER ESCAPE PATH	3351
GALLEY	3327
LAVATORY	
CALL	COMMUNICATIONS
DOME	3326
MIRROR	3326
RETURN TO SEAT	3324
SIGNS	3324
NIGHT	3321
NO SMOKING SIGNS	3324
PASSENGER CALL	COMMUNICATIONS
READING	2334
SEAT BELT SIGNS	3324
SIDEWALL WASHLIGHTS	3322
THRESHOLD	3322
TRACK LIGHTING	3351
WORK	3322

COCKPIT LIGHTS

CHART	3314
COMPASS	3313
DOME	3311
FLIGHT KIT	3314
FLOODLIGHTS	
AISLE STAND	3311
GLARESHIELD	3311
INSTRUMENT PANEL	3311
LIGHT OVERRIDE	3311
MAP	3314
MASTER DIM & TEST SW	3316
MISCELLANEOUS BULBS/LAMPS	3316
PANELS	
AISLE STAND	3313
AUDIO SELECTOR	
PANEL	COMMUNICATIONS
GLARESHIELD	3313
INSTRUMENT	3313
MISCELLANEOUS	3313
OVERHEAD	3313
OVERHEAD CB	3313
SPARE BULBS	2510
THRESHOLD	3322
UTILITY	3314

LIGHTS - INDEX

EFFECTIVITY

ALL

33-INDEX

<u>TITLE</u>	<u>CHAP/SEC</u>
AIR CONDITIONING COMPARTMENT LIGHTS	3331
APU AND TAILCONE COMPARTMENT LIGHTS	3331
CARGO COMPARTMENT LIGHTS - AFT	3337
CARGO COMPARTMENT LIGHTS - FWD	3337
CARGO LOAD EXTERIOR LIGHTS	3331
ELECTRICAL EQUIPMENT CENTER LIGHTS	3331
EXTERIOR EMERGENCY LIGHTS TEST	3351

LIGHTS - INDEX (GROUND)

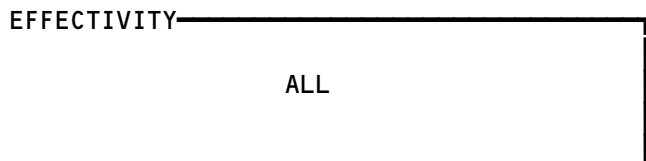

33-INDEX

BOEING

767

FAULT ISOLATION/MAINT MANUAL

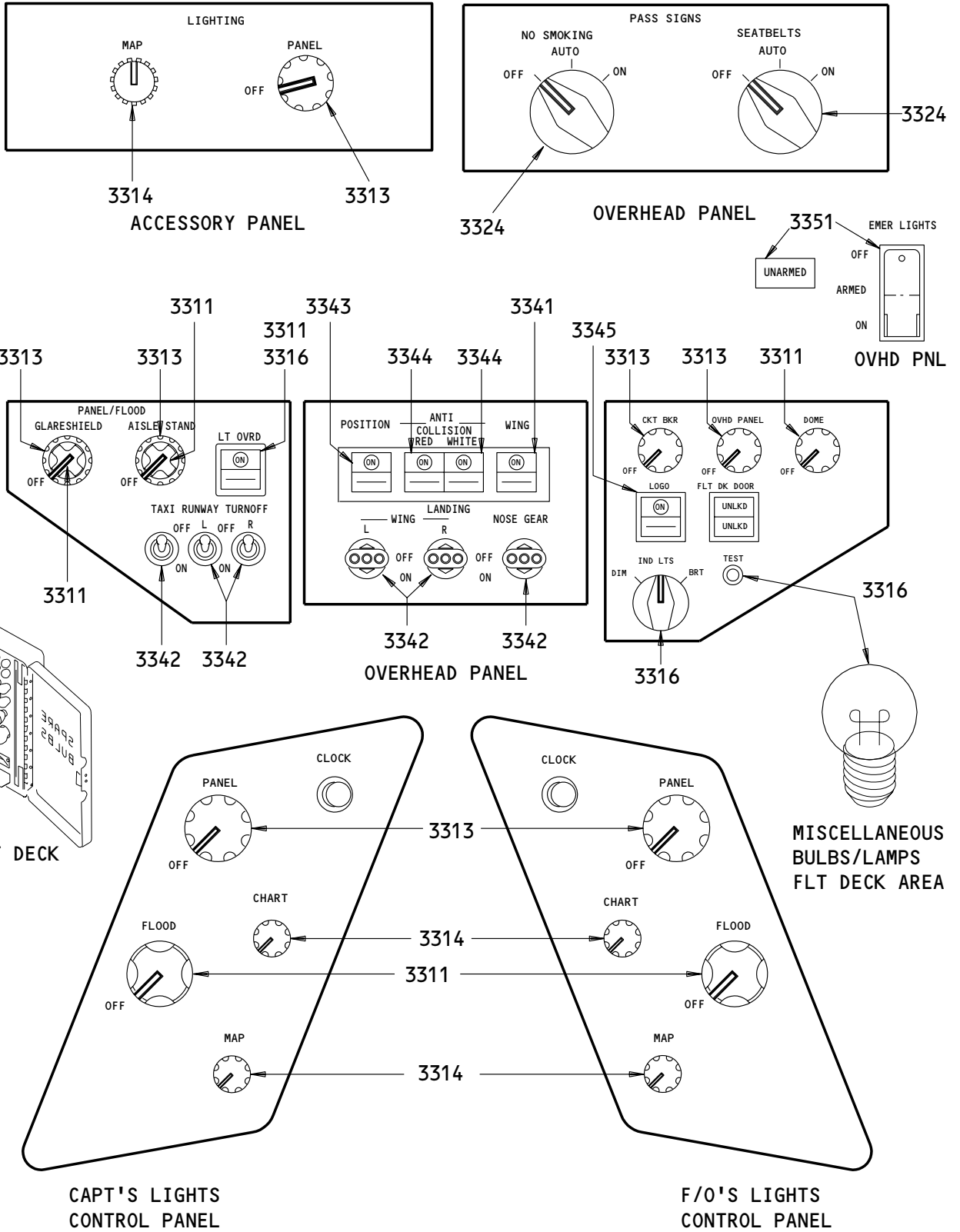

LIGHTS - INDEX

EFFECTIVITY	ALL
-------------	-----

33-INDEX

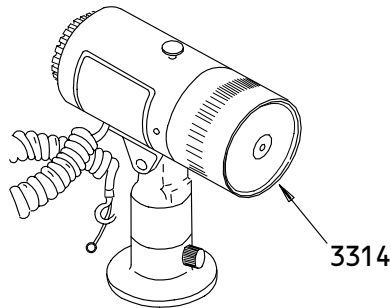
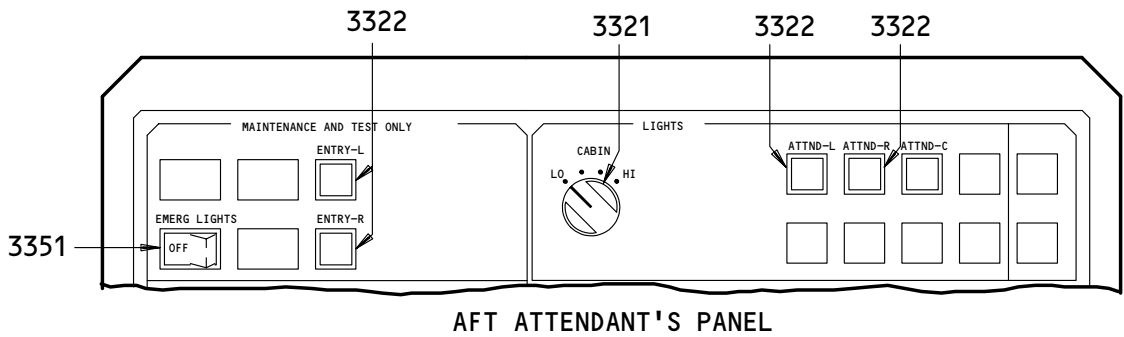
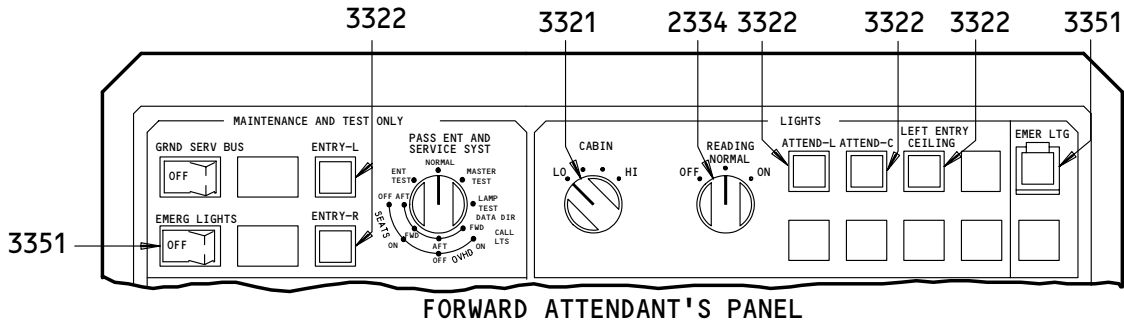

EACH CREWMEMBER STATION

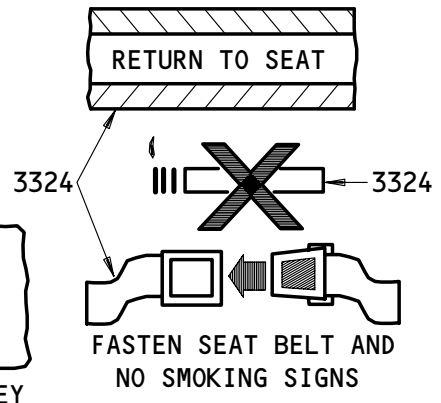
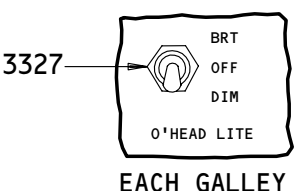
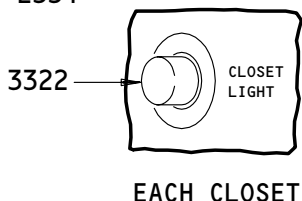
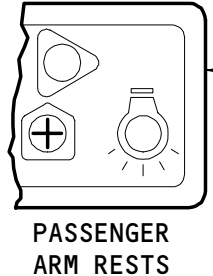
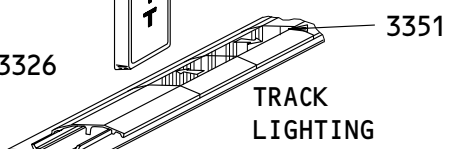
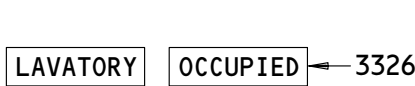
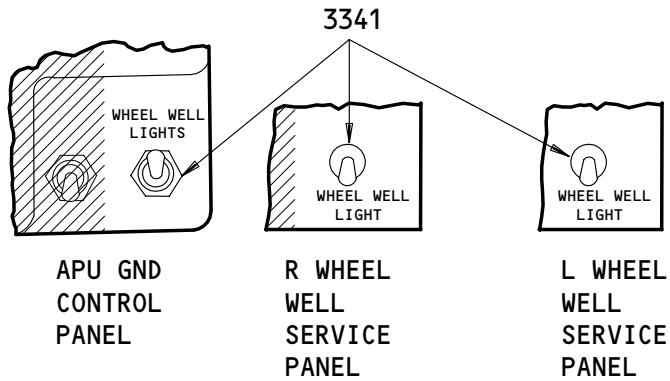

LIGHTS - INDEX

EFFECTIVITY

ALL

33-INDEX

E78463

LIGHTS - EICAS MESSAGE LIST

1. General

- A. This procedure shows the EICAS message locations and gives a list of procedures to find the solution for each message.
 - (1) EICAS Message Locations (Fig. 1)
 - (a) Figure 1 shows the location of the EICAS display units and the area where the messages show on the display units.
 - (b) Each message level has a different location. The location and color of each message level is also shown.
 - (2) The EICAS MESSAGE LIST gives the message, level, and procedure for each message.
 - (a) The EICAS MESSAGE column lists the messages alphabetically. Messages which start with L, R, or C are put together and alphabetized at L.
 - (b) The LEVEL column gives all levels for each message as follows:
 - A - Warning messages
 - B - Caution messages
 - C - Advisory messages
 - S - Status messages
 - M - Maintenance messages
 - (c) The PROCEDURE column gives the steps that are necessary to remove the message and includes one or more of the procedures that follow:
 - 1) A Fault Isolation Manual procedure reference
 - 2) A Maintenance Manual procedure and reference
 - 3) Wiring checks and a Wiring Diagram Manual reference
 - 4) A reference to an EICAS message list in a different chapter.
 - 5) A reference to a FAULT CODE INDEX and specified fault codes
 - 6) A step to change the airplane configuration

EFFECTIVITY

ALL

33-EICAS MESSAGES

01

Page 1
Nov 10/90

BOEING
767
FAULT ISOLATION/MAINT MANUAL

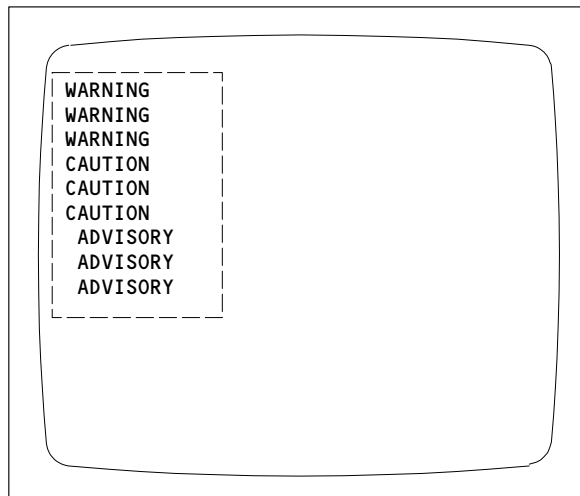
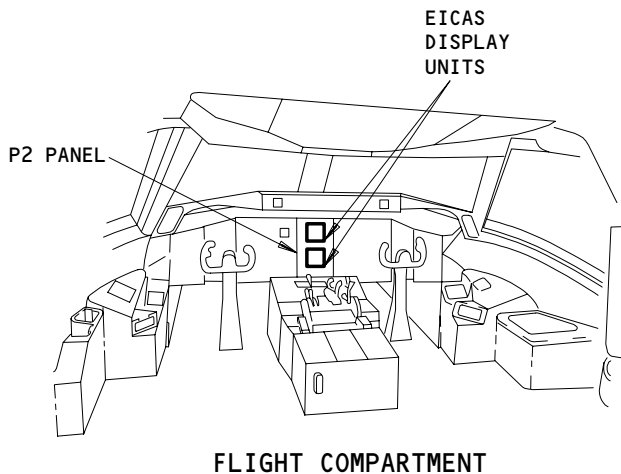

ENGINE PRIMARY PAGE OR COMPACTED PAGE
(TOP DISPLAY UNIT)

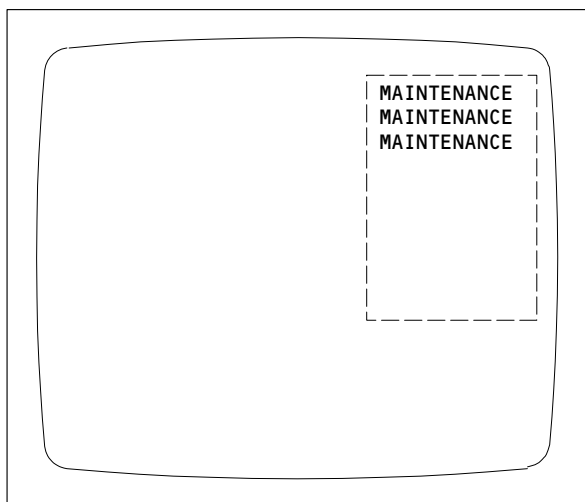

ECS/MSG PAGE
(BOTTOM DISPLAY UNIT)

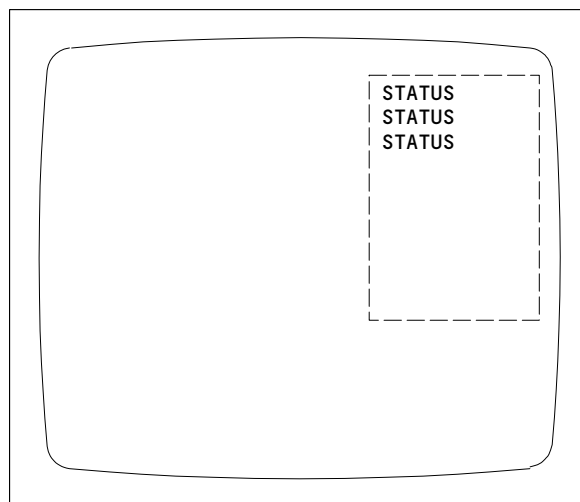

STATUS PAGE
(BOTTOM DISPLAY UNIT)

LEVEL	COLOR
A-WARNING	RED
B-CAUTION	YELLOW
C-ADVISORY	YELLOW
S-STATUS	WHITE
M-MAINTENANCE	WHITE

EICAS Message Locations
Figure 1

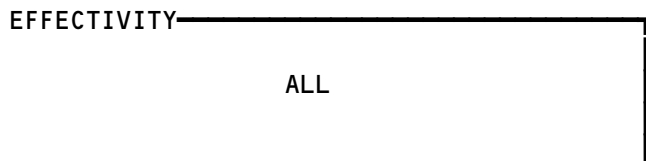

33-EICAS MESSAGES

BOEING
 767
 FAULT ISOLATION/MAINT MANUAL

EICAS MESSAGE LIST		
EICAS MESSAGE	LEVEL	PROCEDURE
EMER LIGHTS	C	Place EMER LIGHTS switch on P5 to ARMED position. If fault persists, replace EMER LIGHTS switch YBIS1 (WDM 33-51-11).

EFFECTIVITY

ALL

33-EICAS MESSAGES

01

Page 3
Nov 10/90

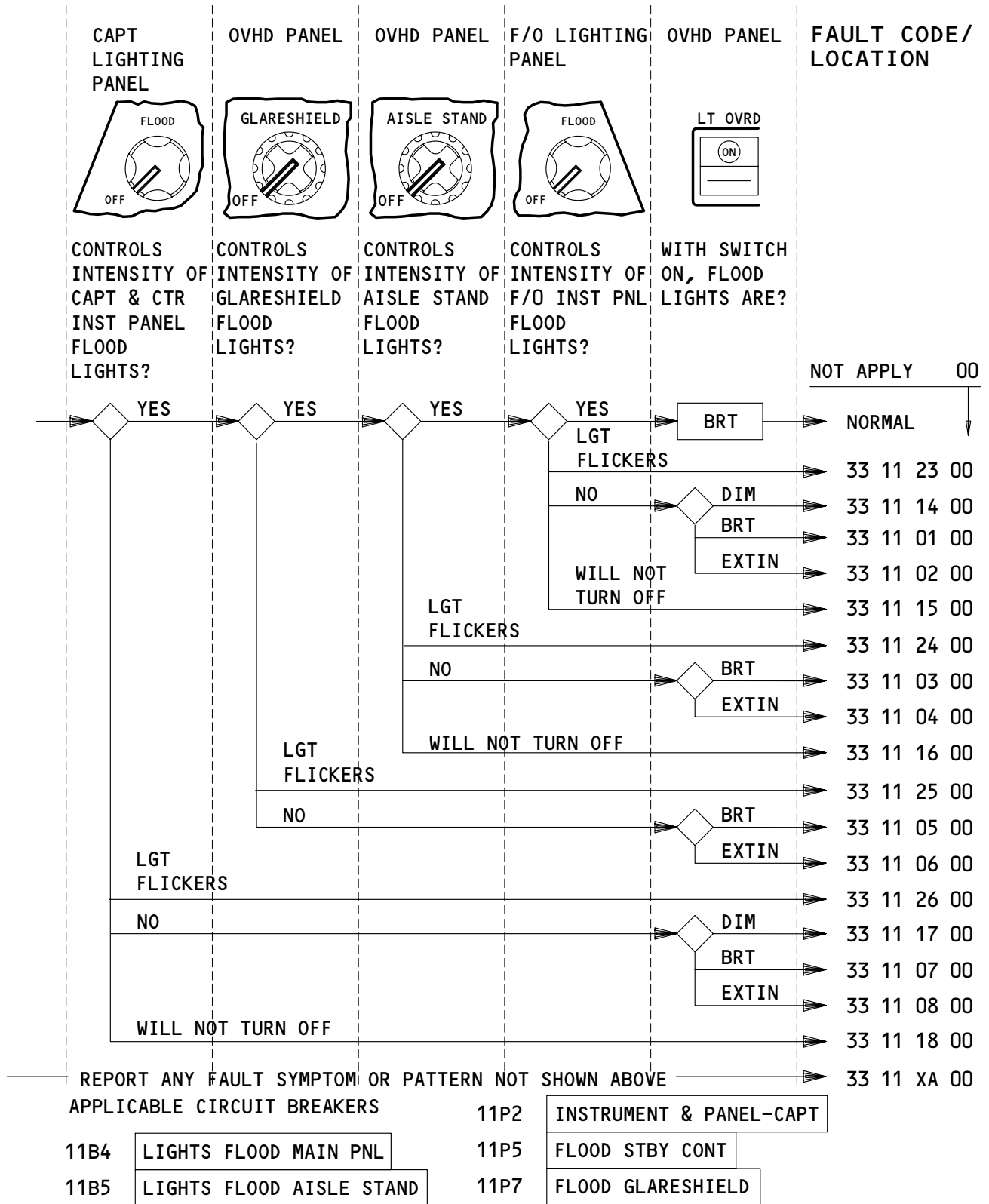

FLOODLIGHTS - FAULT CODES

EFFECTIVITY

ALL

33-FAULT CODE DIAGRAM

01

Page 1
Nov 01/84

BOEING
 767
 FAULT ISOLATION/MAINT MANUAL

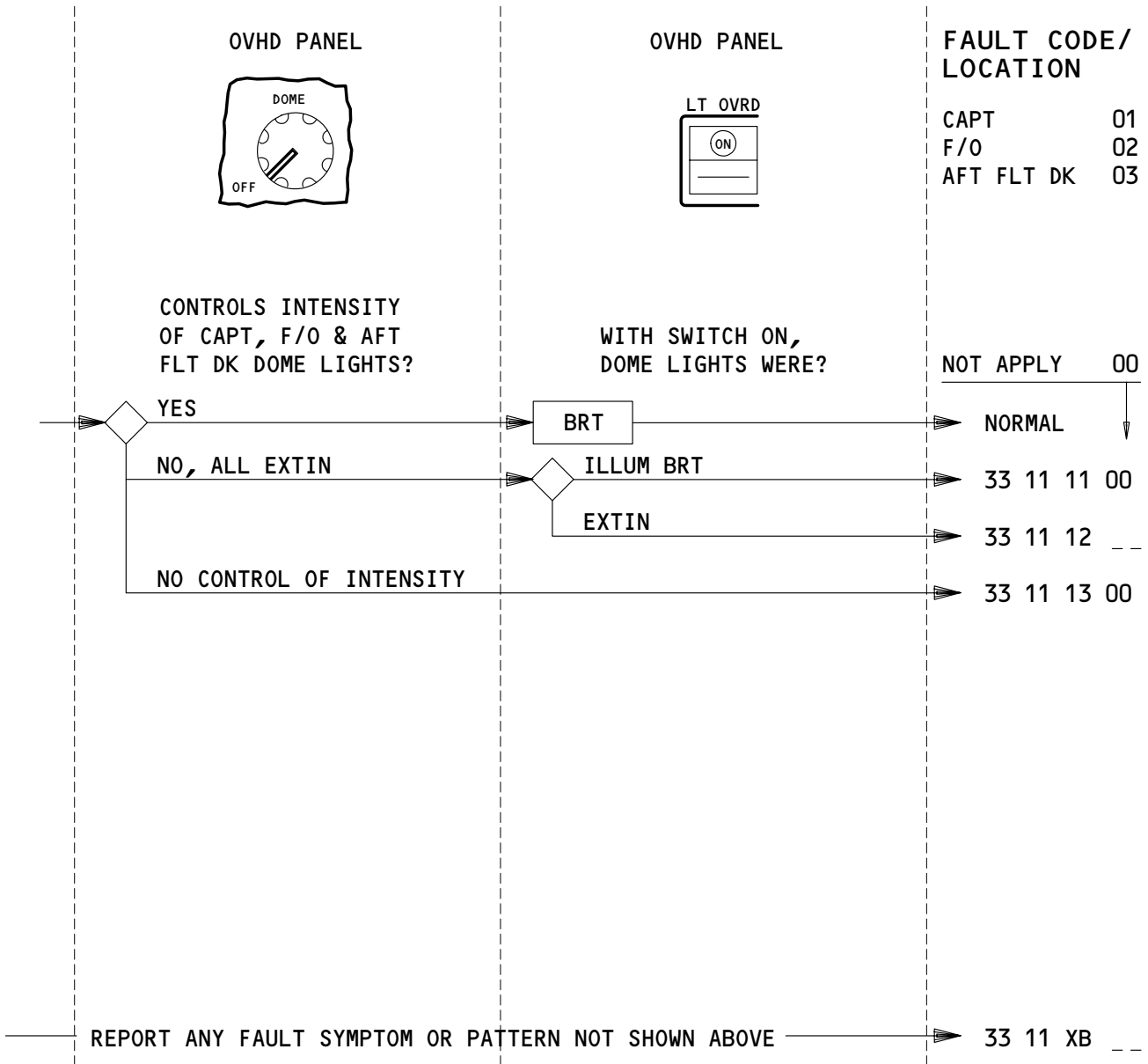

APPLICABLE CIRCUIT BREAKERS

DOME LIGHTS - FAULT CODES

EFFECTIVITY

ALL

33-FAULT CODE DIAGRAM

03

Page 2
May 01/86

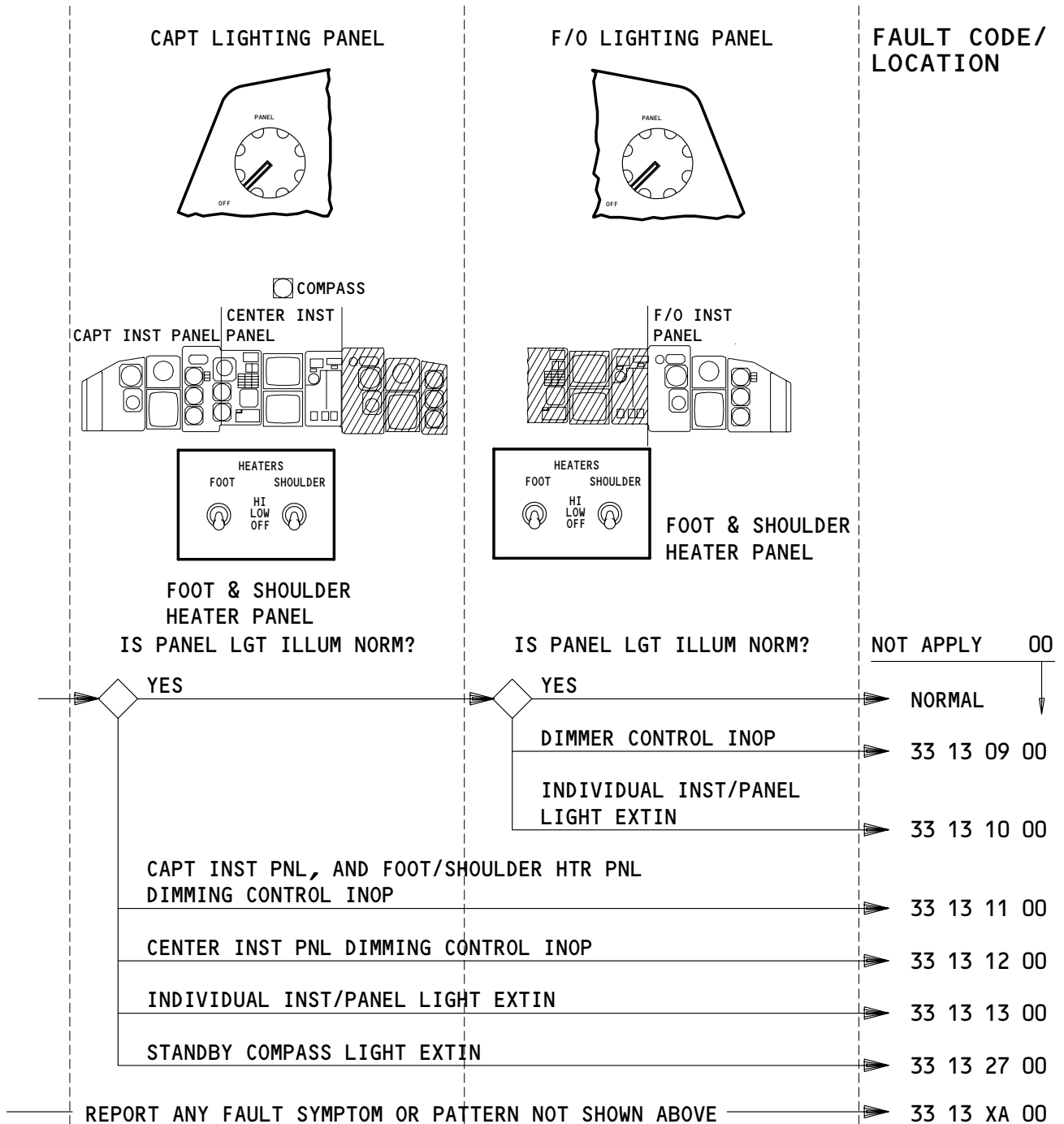

APPLICABLE CIRCUIT BREAKERS

11P2	INSTRUMENT & PANEL CAPT
11P28	INSTRUMENT & PANEL F/O

PILOTS' INSTRUMENT/MISC PANEL LIGHTING - FAULT CODES

EFFECTIVITY

ALL

33-FAULT CODE DIAGRAM

01

Page 3
Feb 10/96

BOEING

767

FAULT ISOLATION/MAINT MANUAL

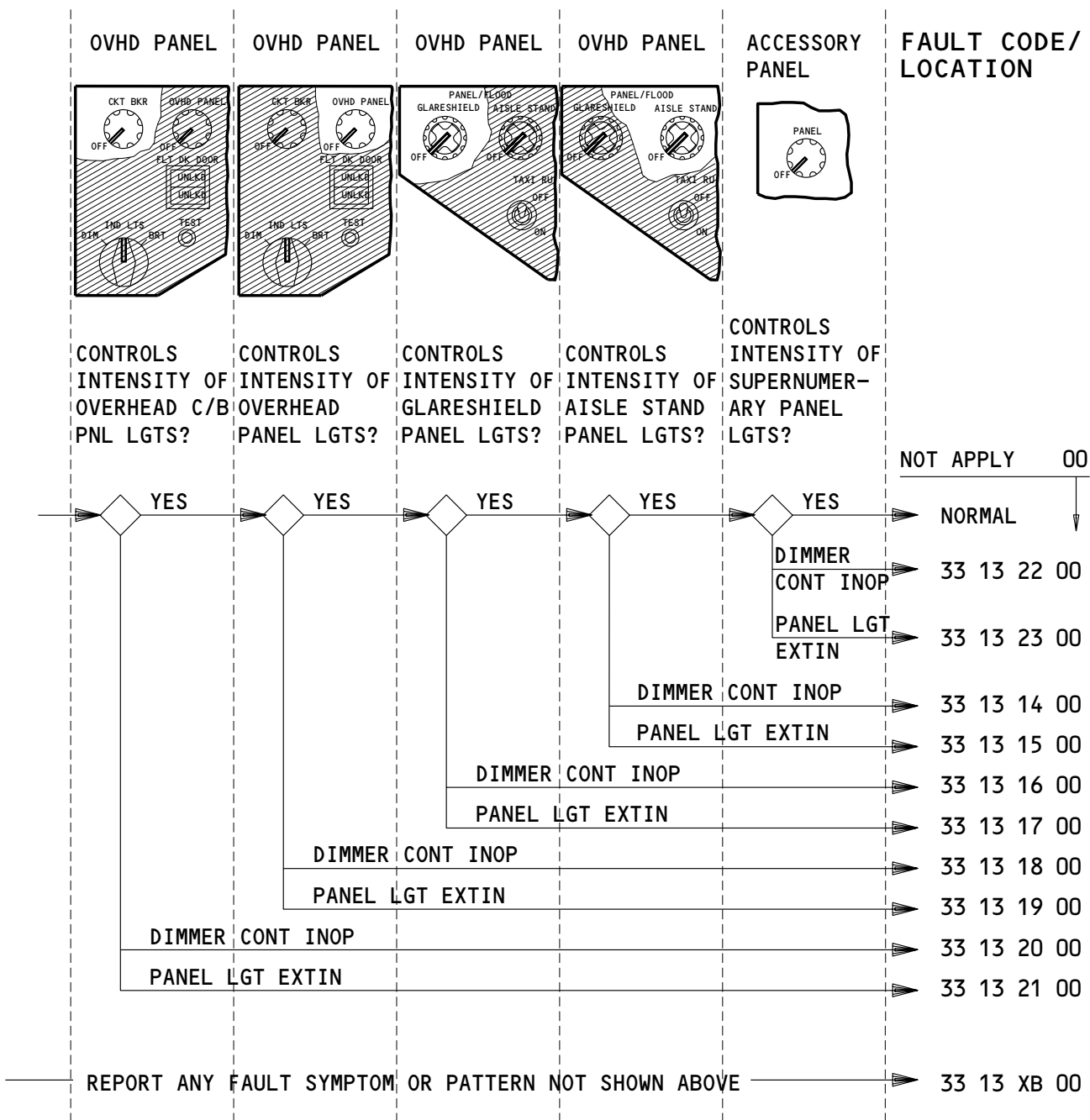

APPLICABLE CIRCUIT BREAKERS AS INSTALLED

11B7	LIGHTS(-)STBY INSTR	11P4	INSTRUMENT & PANEL OVHD (C/B, CB)
11P1	INSTRUMENT & PANEL AISLE STAND	11P28	INSTRUMENT & PANEL F/O
11P3	INSTRUMENT & PANEL OVHD	11P30	INSTRUMENT & PANEL GLARESHIELD

OVERHEAD, GLARESHIELD, AISLE STAND AND SUPERNUMERARY PANEL LIGHTS - FAULT CODES

EFFECTIVITY

ALL

33-FAULT CODE DIAGRAM

F94917

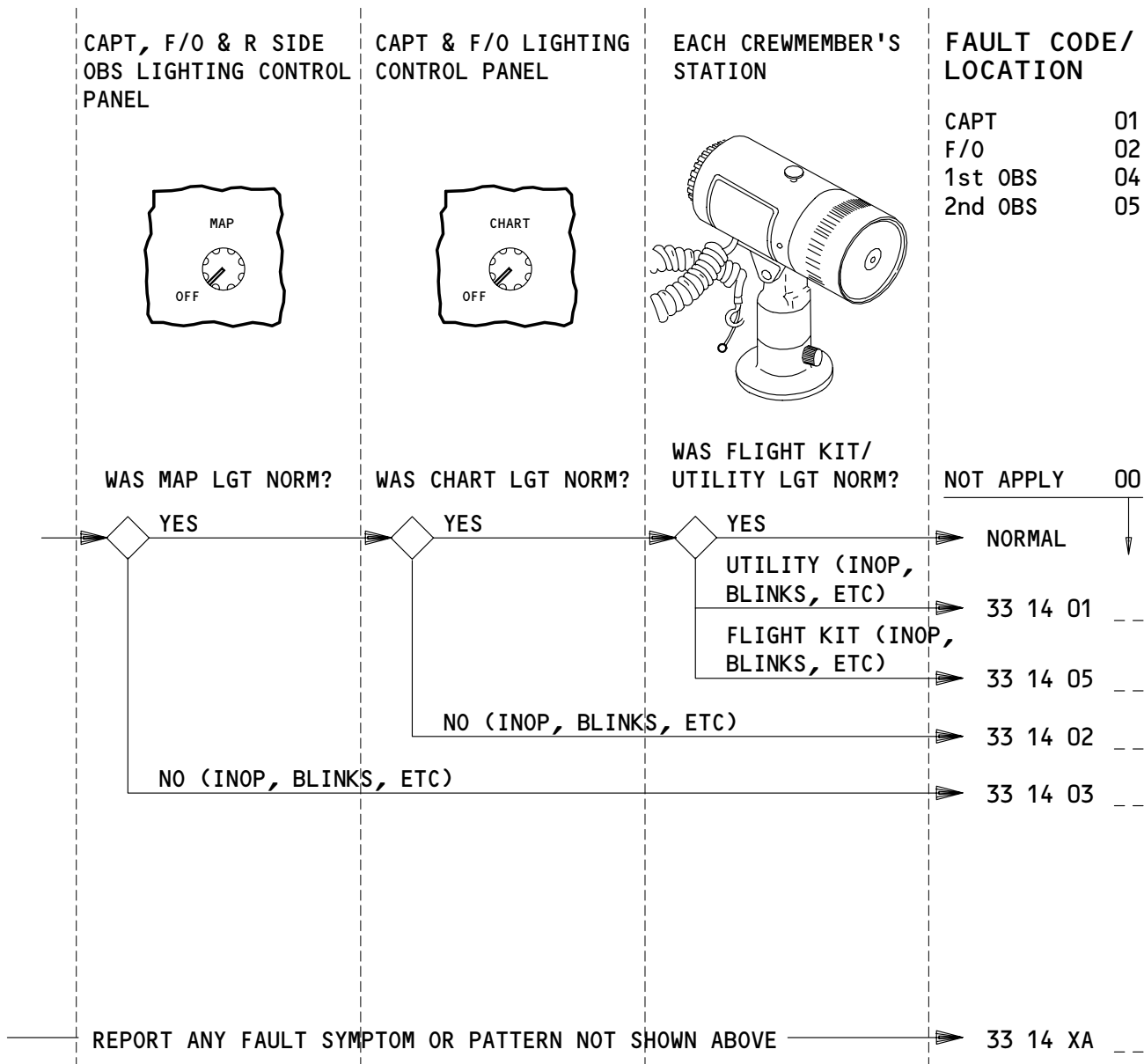

APPLICABLE CIRCUIT BREAKERS

- 11P8 CHART
- 11P31 MAP
- 11P32 UTILITY

MAP, CHART, FLIGHT KIT/UTILITY LIGHTS - FAULT CODES

EFFECTIVITY

ALL

33-FAULT CODE DIAGRAM

BOEING

767 FAULT ISOLATION/MAINT MANUAL

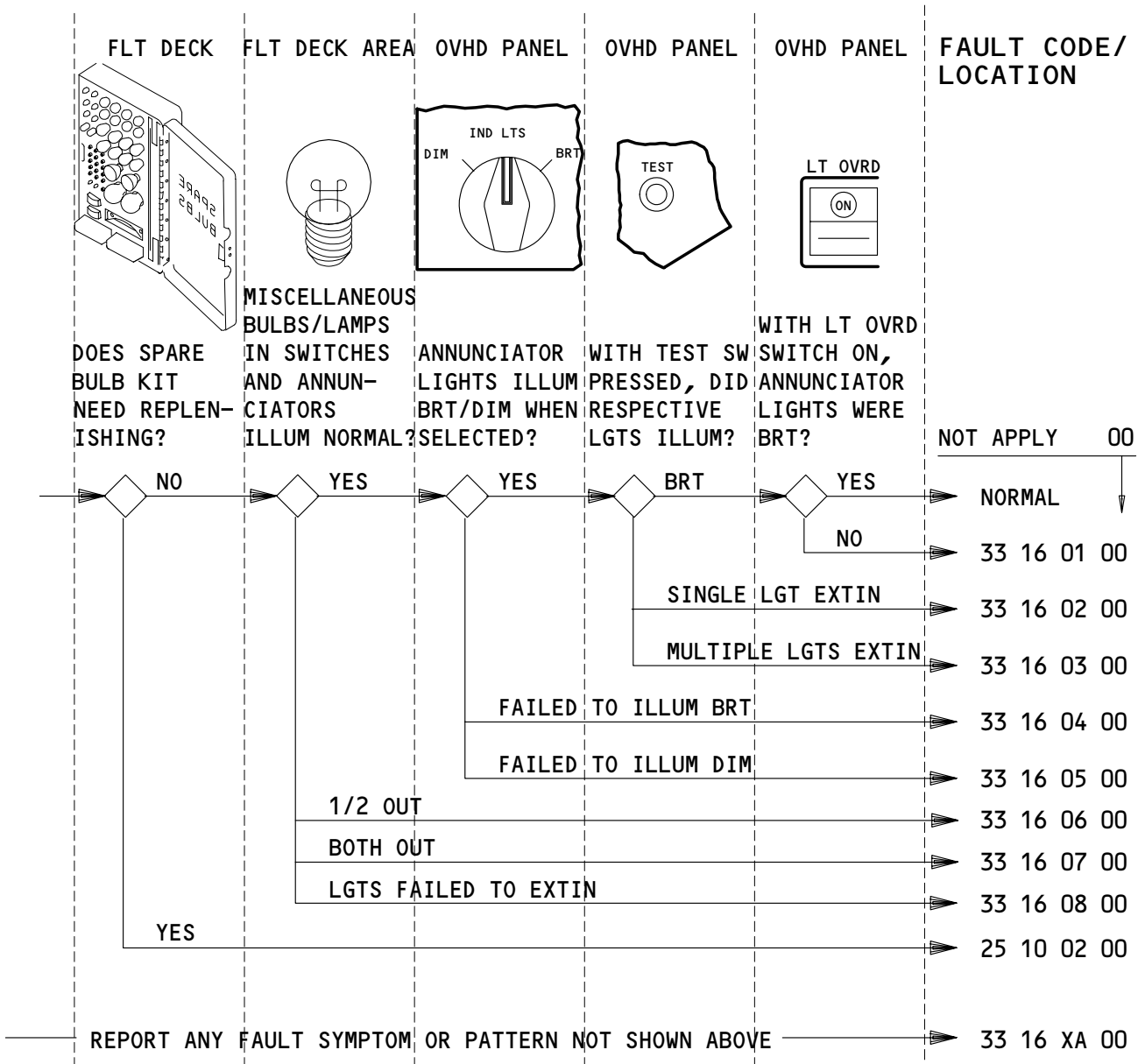

APPLICABLE CIRCUIT BREAKERS

11A32	IND LIGHTS TEST	11R3	LEFT IND LTS 3
11A33	IND LIGHTS 1	11R5	IND LTS DIM CONT
11A34	IND LIGHTS 2	11R28	RIGHT IND LTS 1
11A35	IND LIGHTS 3	11R29	RIGHT IND LTS 2
11R1	LEFT IND LTS 1	11R30	RIGHT IND LTS 3
11R2	LEFT IND LTS 2		

MISCELLANEOUS BULBS/MASTER DIM AND TEST – FAULT CODES

EFFECTIVITY

ALL

33-FAULT CODE DIAGRAM

05

Page 6
Feb 01/86

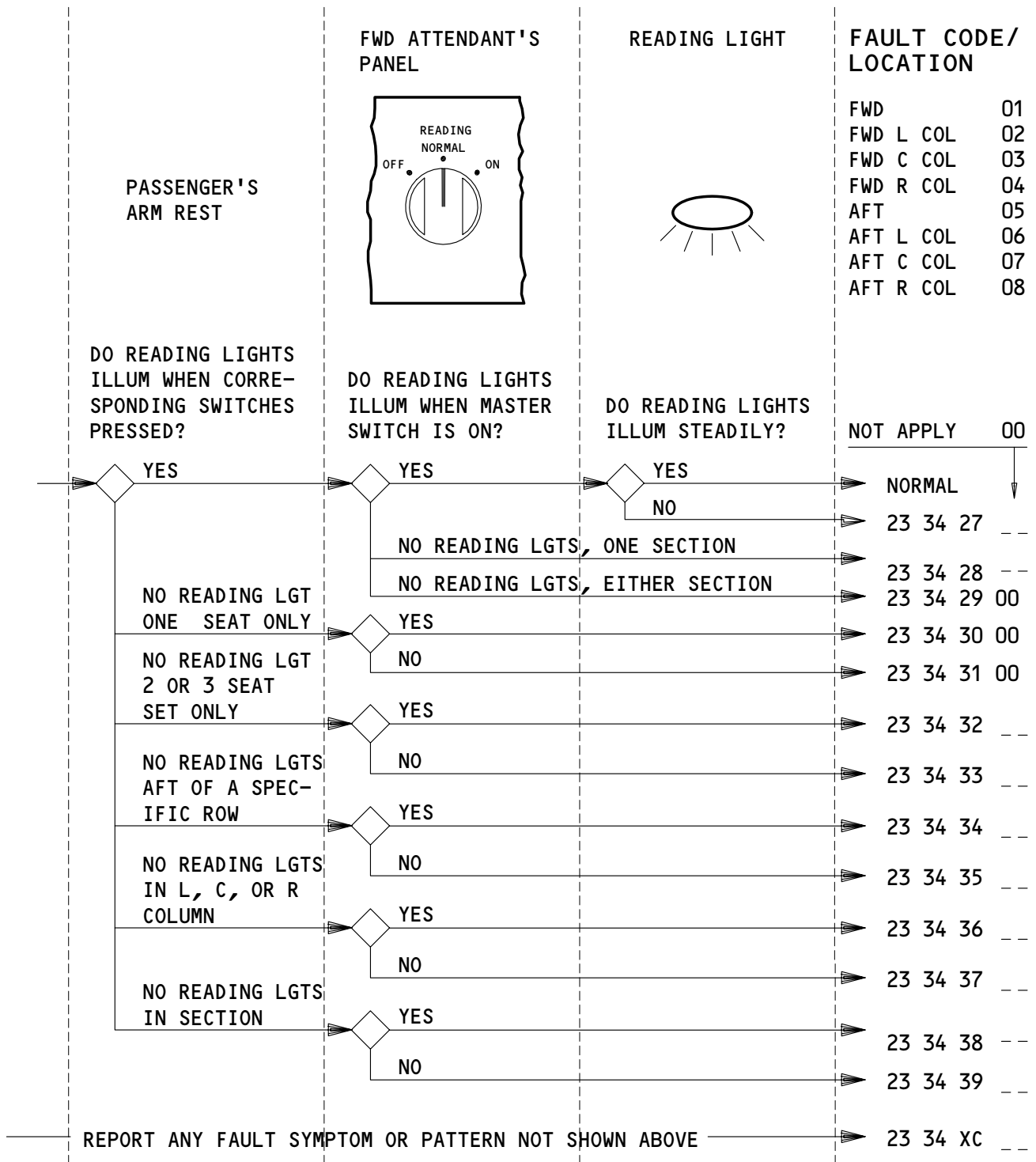

APPLICABLE CIRCUIT BREAKERS

11T8 PASS ENTMT/SERVICE CONT

READING LIGHTS - FAULT CODES

EFFECTIVITY

ALL

33-FAULT CODE DIAGRAM

01

Page 7
Nov 10/95

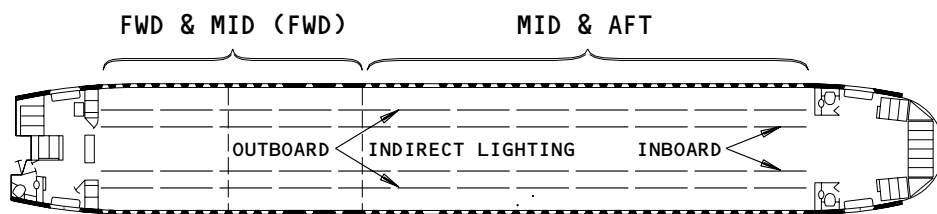

FAULT CODE/
LOCATION

ATTENDANT'S PANELS

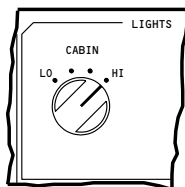

AFT

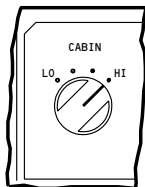

FWD

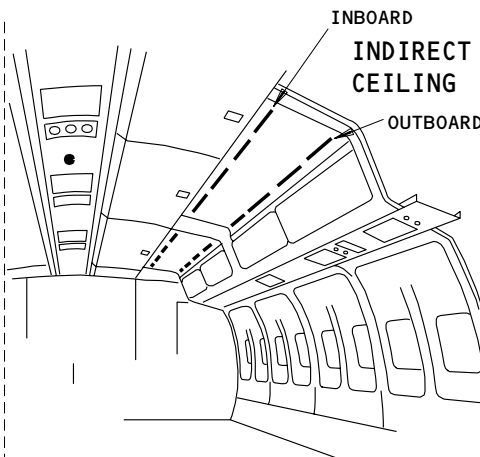

ARE FWD/AFT SWITCHES IN HI POSITION?

YES

ALL ILLUM

NOT APPLY 00

NORMAL

ONE OR TWO EXTIN, FLICKERS
(REPORT BY NEAREST AISLE
SEAT NO.)

33 21 01 00

ALL FWD & MID (FWD) EXTIN
(SEE TOP OF PAGE)

33 21 02 00

ALL MID & AFT INBD EXTIN

33 21 03 00

ALL MID & AFT OUTBD EXTIN

33 21 04 00

REPORT ANY FAULT SYMPTOM OR PATTERN NOT SHOWN ABOVE

33 21 XA 00

APPLICABLE CIRCUIT BREAKERS

FWD EQUIPMENT CENTER

INDIRECT CEILING LIGHTS - FAULT CODES

EFFECTIVITY

ALL

33-FAULT CODE DIAGRAM

01

Page 8
Aug 01/82

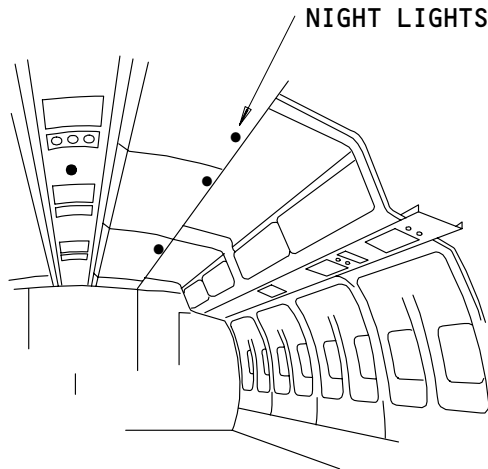

FAULT CODE/
LOCATION

**FORWARD ATTENDANT
CONTROL PANEL**

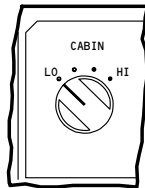

**AFT ATTENDANT
CONTROL PANEL**

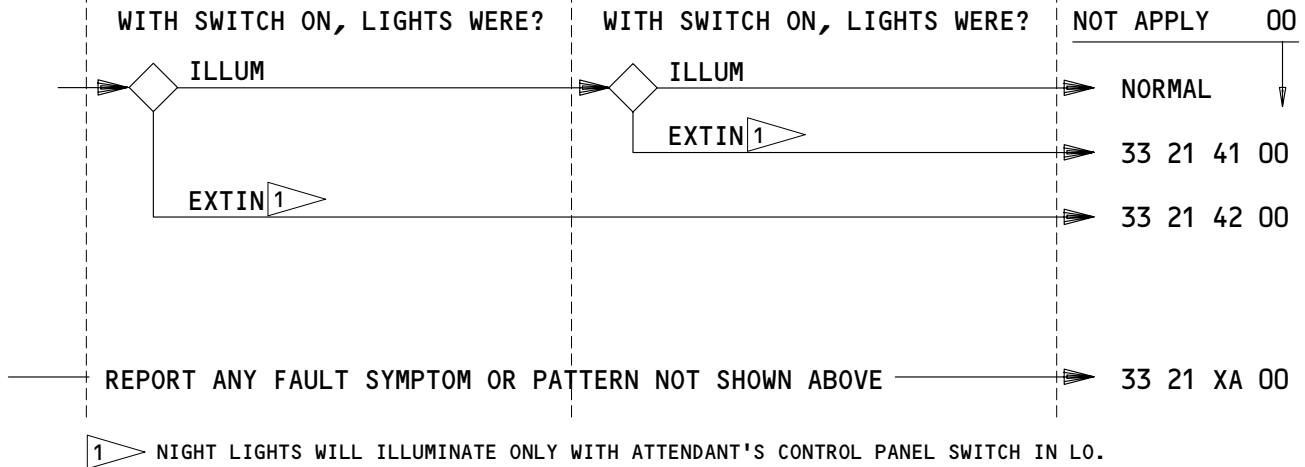
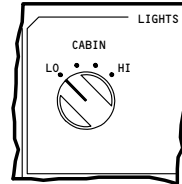

APPLICABLE CIRCUIT BREAKERS

11R32 NIGHT FWD

NIGHT LIGHTS - FAULT CODES

EFFECTIVITY	ALL
-------------	-----

33-FAULT CODE DIAGRAM

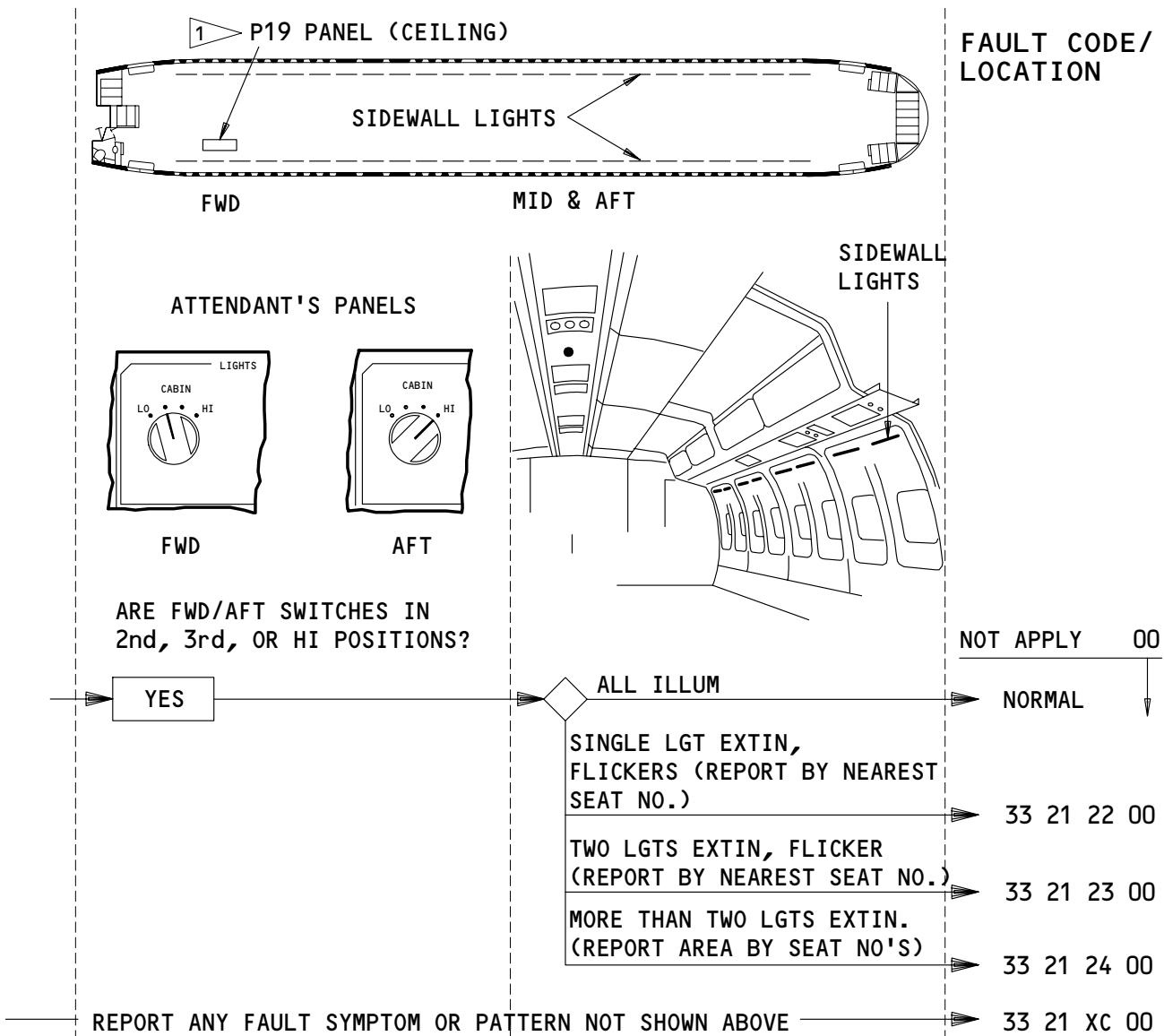

1 LIGHTS MAY BE CONTROLLED FROM THE FWD OR AFT ATTENDANTS PANEL DEPENDING ON FLEXIBILITY SWITCH POSITION ON P19. (LOCATED BEHIND PANEL IN FWD COMPT CEILING).

APPLICABLE CIRCUIT BREAKERS
FWD EQUIPMENT CENTER

SIDEWALL WASHLIGHTS - FAULT CODES

EFFECTIVITY
ALL

33-FAULT CODE DIAGRAM

123730

Not Used
Figure 11

EFFECTIVITY

ALL

33-FAULT CODE DIAGRAM

01

Page 11
Nov 10/95

FORWARD ATTENDANT'S
CONTROL PANEL

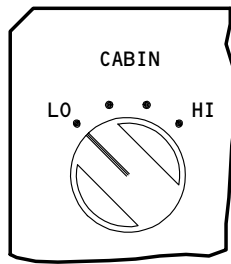

AFT ATTENDANT'S
CONTROL PANEL

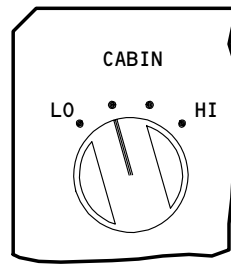

FAULT CODE/
LOCATION

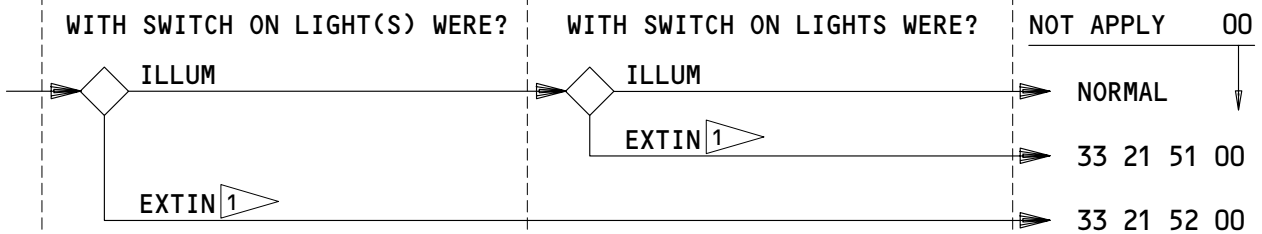

REPORT ANY FAULT SYMPTOM OR PATTERN NOT SHOWN ABOVE → 33 21 XA 00

1 CHECK LIGHT IN EACH OF THE FOUR SWITCH POSITIONS. IT IS NORMAL FOR A LIGHT TO REMAIN EXTINGUISHED IN ONE OR TWO OR THREE OF THE SWITCH POSITIONS BUT NOT ALL FOUR. THE FLIGHT DECK DOOR MUST BE CLOSED FOR THE FORWARD MOST LIGHT TO ILLUMINATE.

APPLICABLE CIRCUIT BREAKERS

11R32 NIGHT FWD

FWD EQUIPMENT CENTER

DIRECT CEILING LIGHTS - FAULT CODES

EFFECTIVITY

ALL

33-FAULT CODE DIAGRAM

01

Page 12
Nov 10/95

Not Used
Figure 13

EFFECTIVITY

ALL

33-FAULT CODE DIAGRAM

01

Page 13
Aug 10/98

H63136

BOEING
767
FAULT ISOLATION/MAINT MANUAL

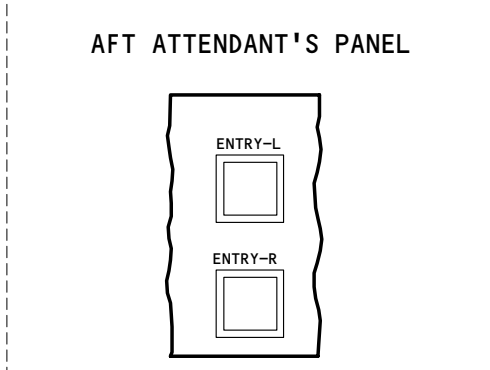
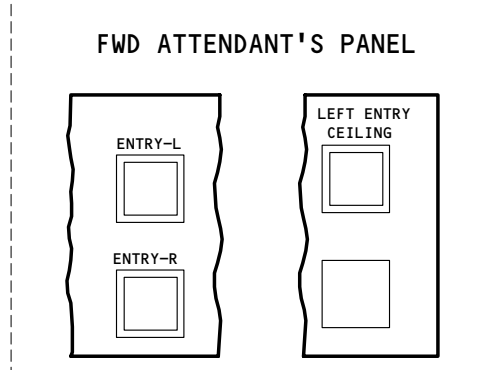

FAULT CODE/ LOCATION

FWD L ENTRY	
CEILING	01
FWD L ENTRY	02
FWD R ENTRY	03
AFT L ENTRY	04
AFT R ENTRY	05

WITH FWD ENTRY DOOR OPEN AND SWITCHES ON, FWD ENTRY LIGHTS ARE:

WITH AFT ENTRY DOOR OPEN AND SWITCHES ON, AFT ENTRY LIGHTS ARE:

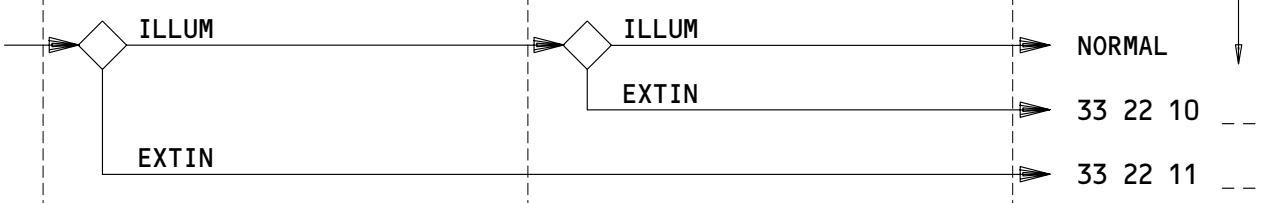

REPORT ANY FAULT SYMPTOM OR PATTERN NOT SHOWN ABOVE → 33 22 XC _ _

APPLICABLE CIRCUIT BREAKERS
FWD EQUIP CTR
11U28 ENT LTS POT WATER

THRESHOLD ENTRY LIGHTS - FAULT CODES

EFFECTIVITY ————
ALL

33-FAULT CODE DIAGRAM

160898

CLOSET LIGHTS

FAULT CODE/
LOCATION

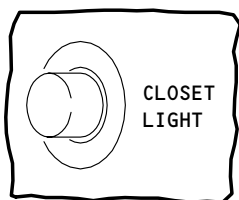

DID LGT(S) ILLUM?

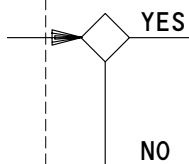

NOT APPLY 00
NORMAL
33 22 29 00

REPORT ANY FAULT SYMPTOM OR PATTERN NOT SHOWN ABOVE → 33 22 XD 00

APPLICABLE CIRCUIT BREAKERS

NONE

CLOSET LIGHTS – FAULT CODES

EFFECTIVITY

ALL

33-FAULT CODE DIAGRAM

02

Page 15
Aug 10/98

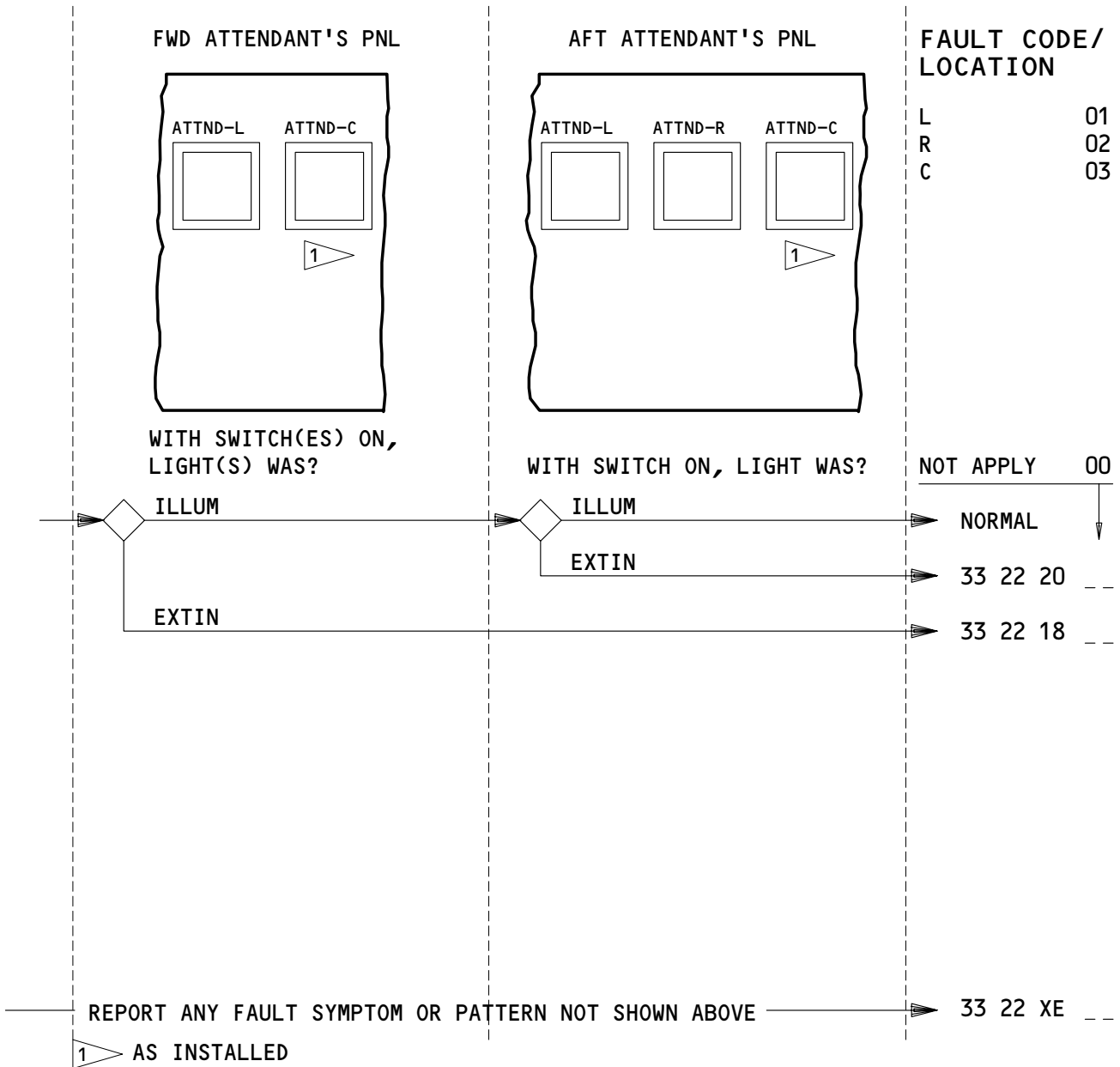

APPLICABLE CIRCUIT BREAKERS
FWD EQUIPMENT CENTER

ATTENDANT'S WORK LIGHTS - FAULT CODES

EFFECTIVITY

ALL

33-FAULT CODE DIAGRAM

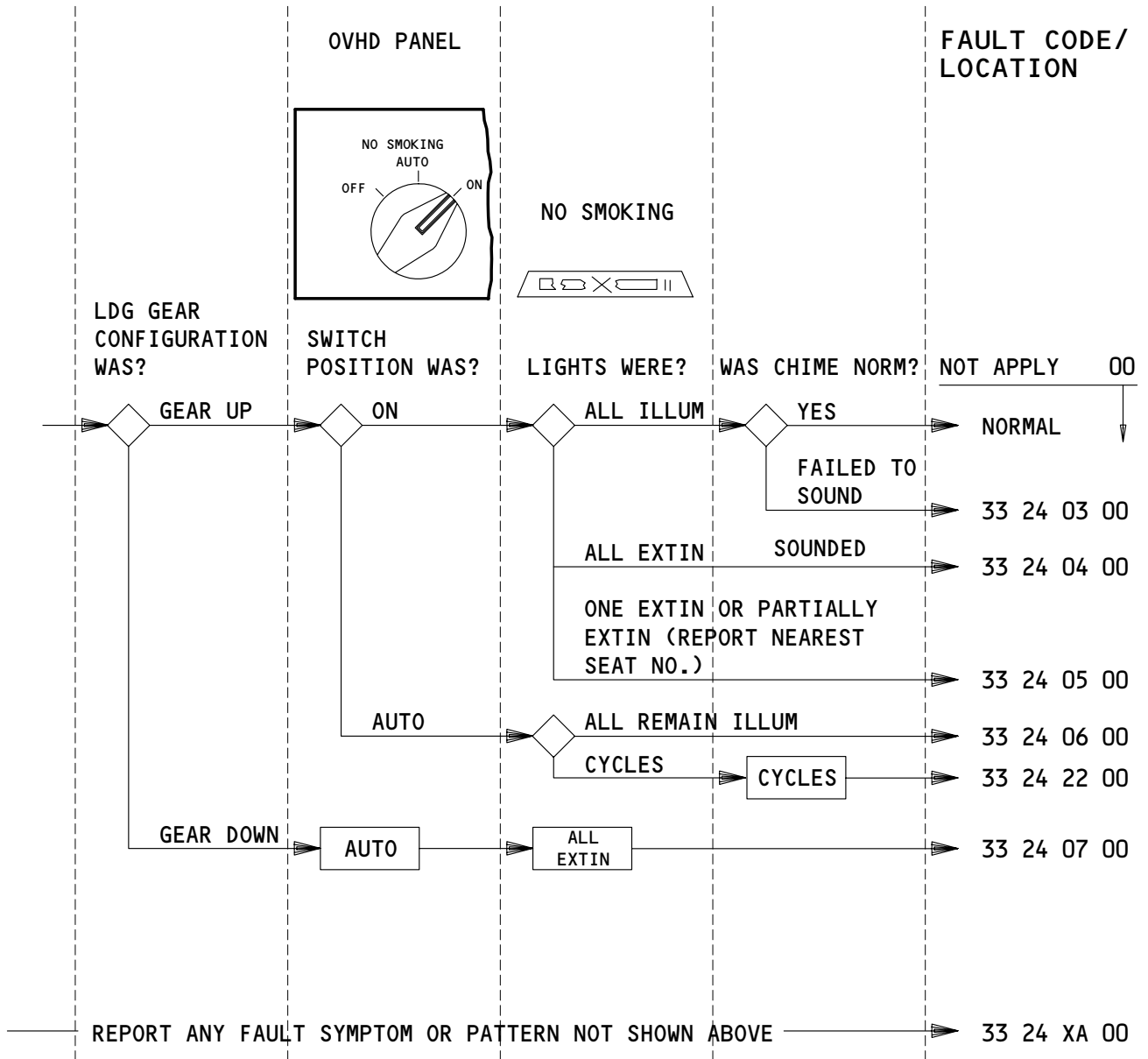

APPLICABLE CIRCUIT BREAKERS

11P9 PASS SIGN CONT

NO SMOKING LIGHTS - FAULT CODES

EFFECTIVITY

ALL

33-FAULT CODE DIAGRAM

01

Page 17
Aug 10/98

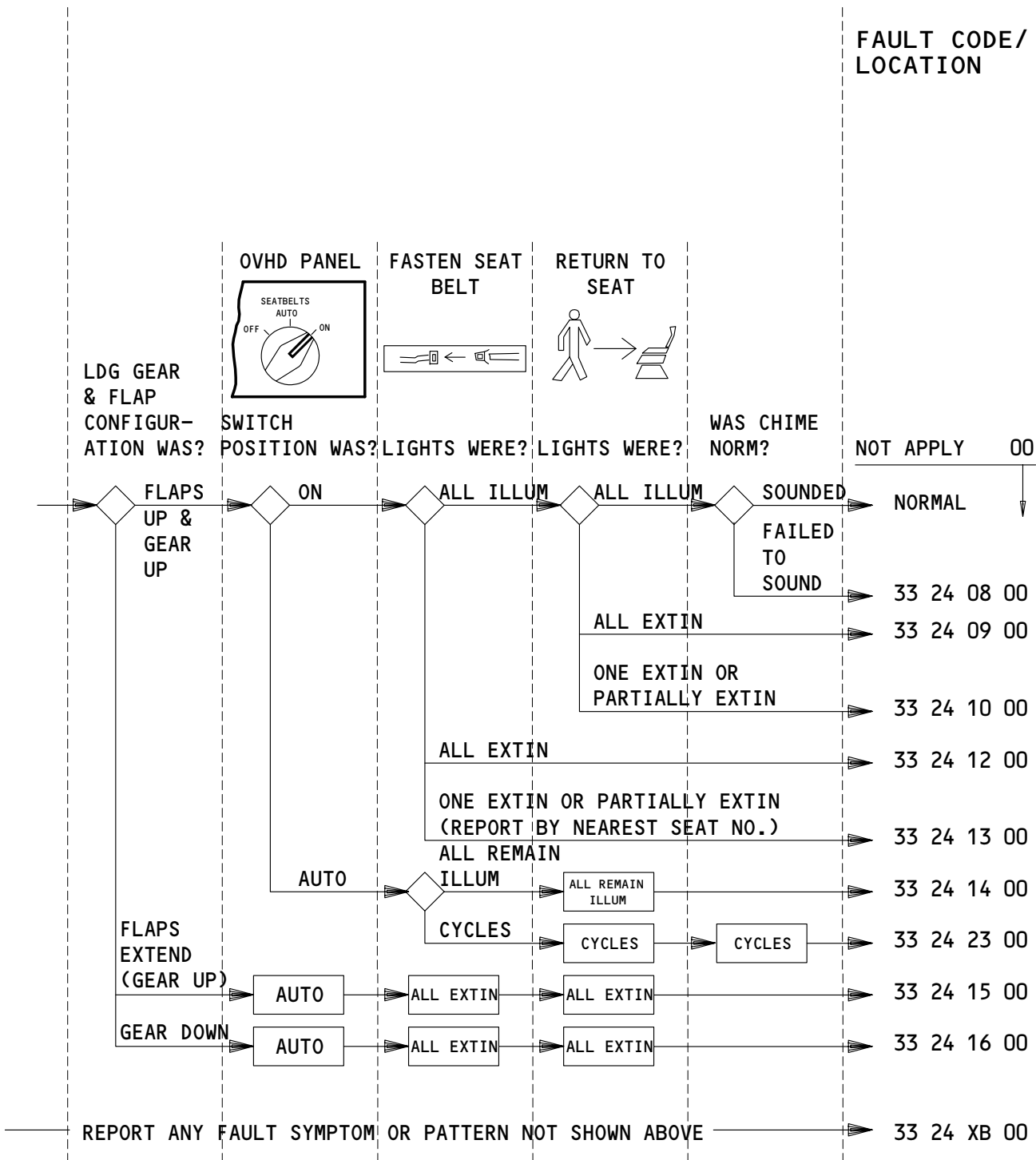

APPLICABLE CIRCUIT BREAKERS

11P9 PASS SIGN CONT

SEATBELTS/RETURN TO SEAT LIGHTS – FAULT CODES

EFFECTIVITY

ALL

33-FAULT CODE DIAGRAM

01

Page 18
Aug 10/98

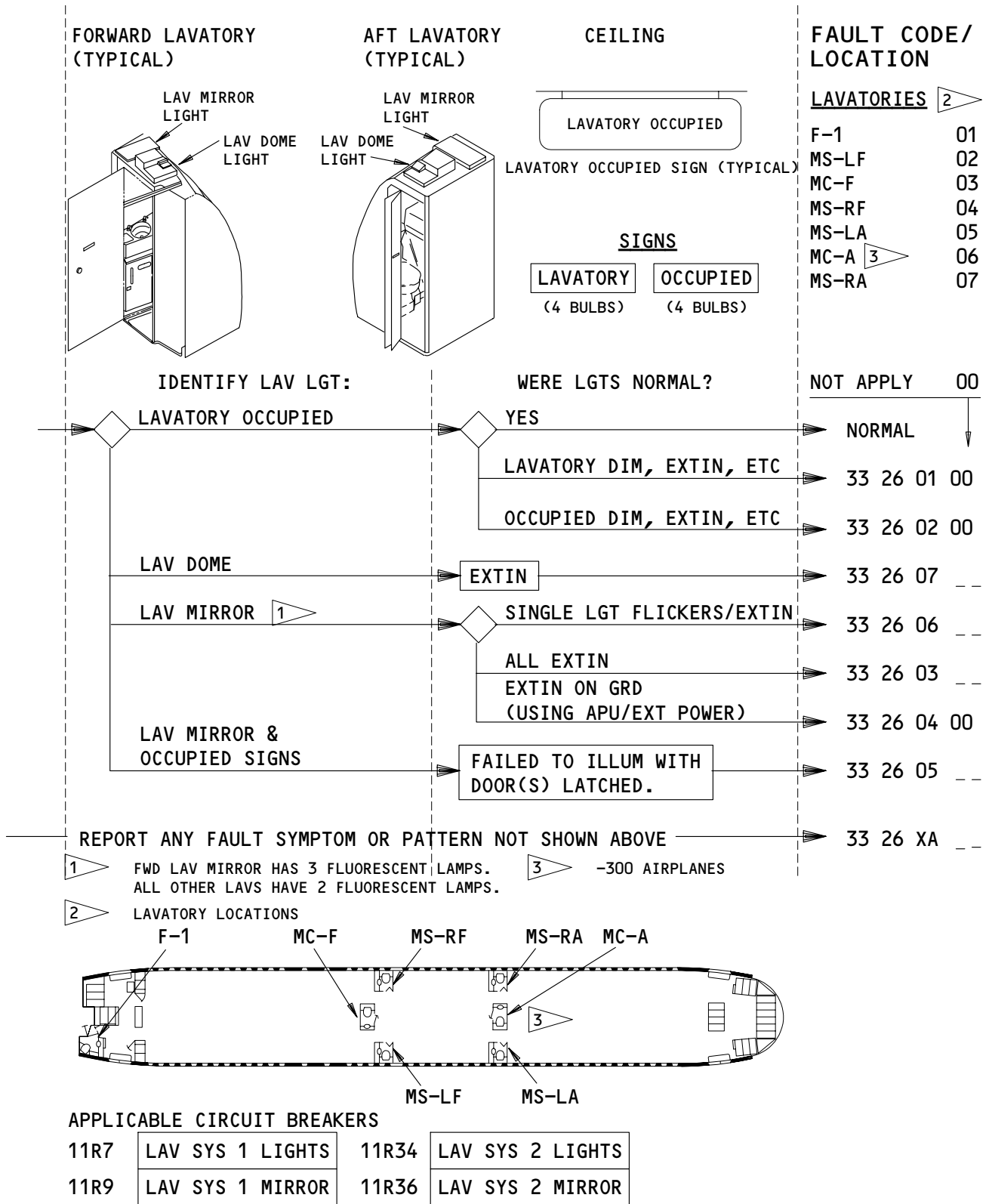

LAVATORY LIGHTS - FAULT CODES

EFFECTIVITY
SAS AIRPLANES

33-FAULT CODE DIAGRAM

FORWARD LAVATORY (TYPICAL)

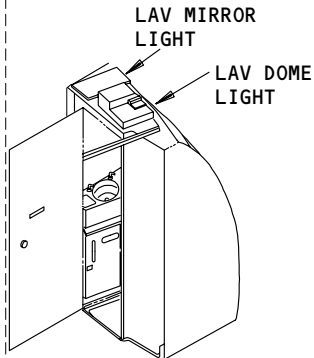

AFT LAVATORY (TYPICAL)

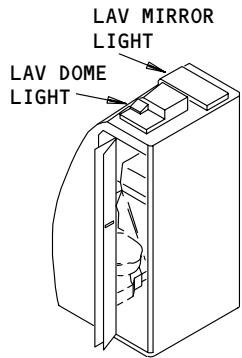

CEILING

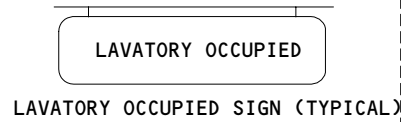

SIGNS

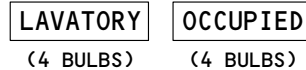

FAULT CODE/LOCATION

<u>LAVATORIES</u> 2	
A	01
B	02
C	03
D	04
E	05
F	06

IDENTIFY LAV LGT:

WERE LGTS NORMAL?

NOT APPLY 00

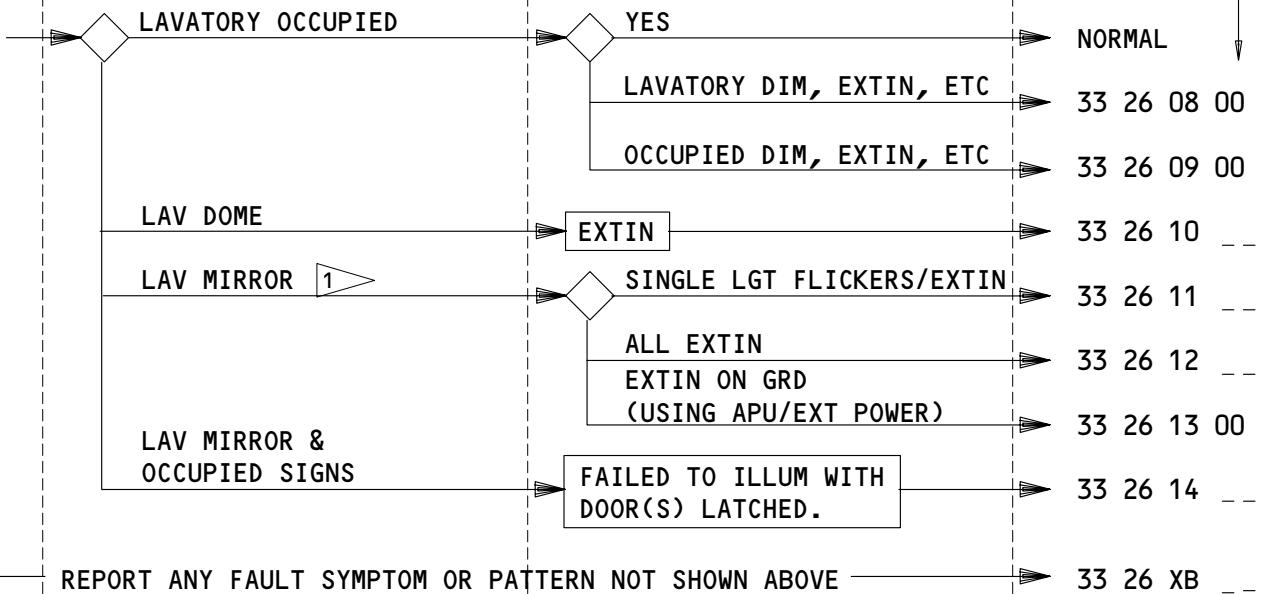

1 FWD LAV MIRROR HAS 3 FLUORESCENT LAMPS. ALL OTHER LAVS HAVE 2 FLUORESCENT LAMPS.

2 LAVATORY LOCATIONS

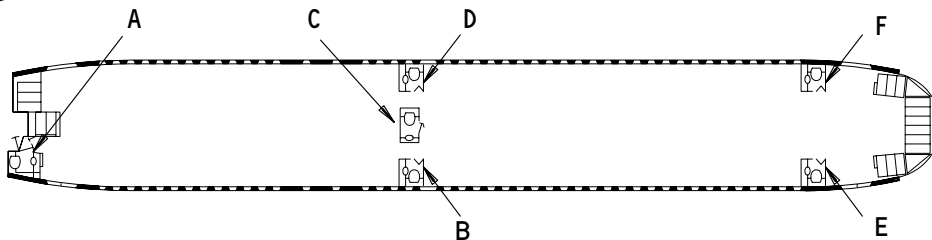

APPLICABLE CIRCUIT BREAKERS

11R7	LAV SYS 1 LIGHTS	11R34	LAV SYS 2 LIGHTS
11R9	LAV SYS 1 MIRROR	11R36	LAV SYS 2 MIRROR

LAVATORY LIGHTS - FAULT CODES

EFFECTIVITY
MTH AIRPLANES

33-FAULT CODE DIAGRAM

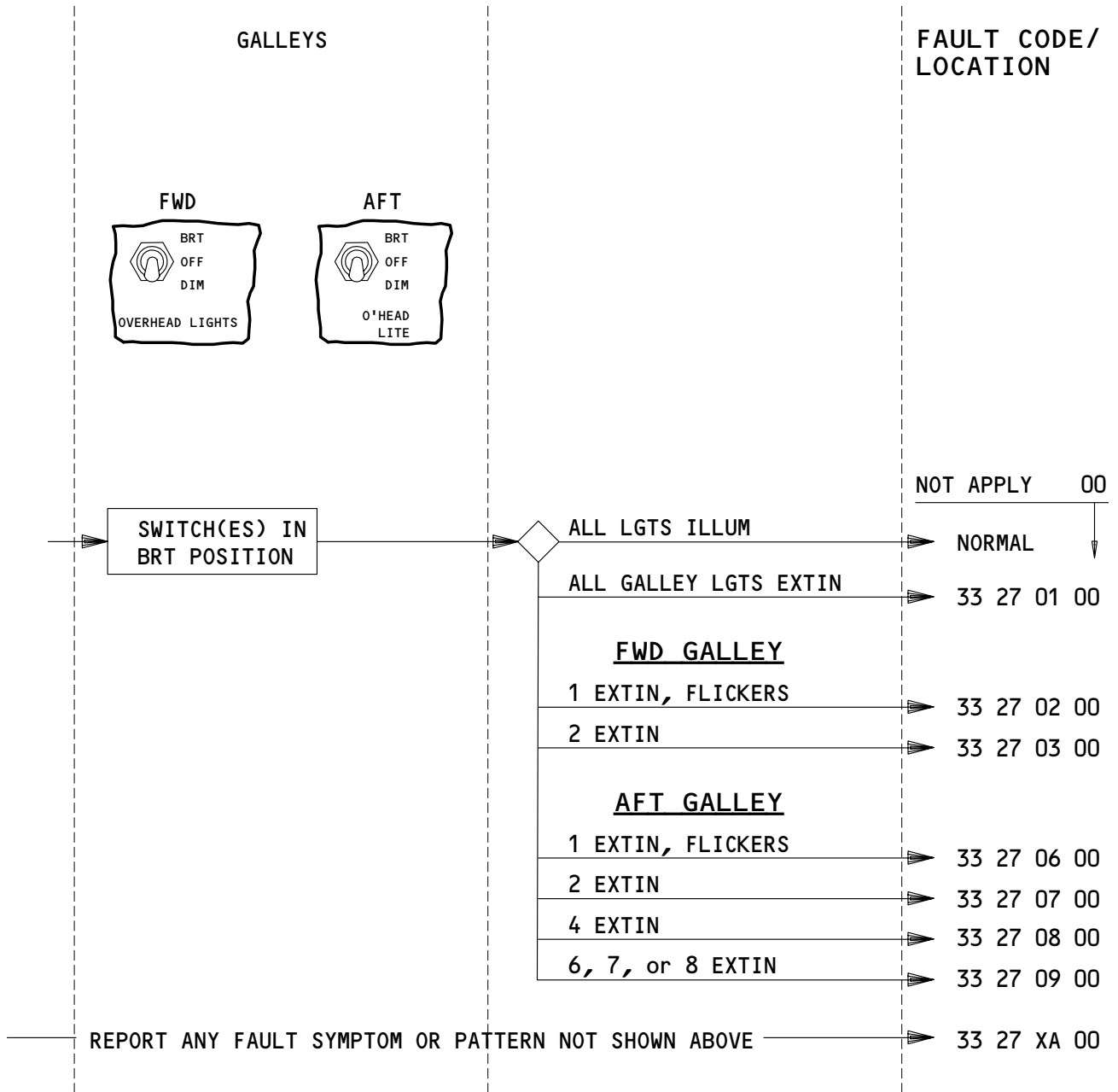

APPLICABLE CIRCUIT BREAKERS

FWD EQUIPMENT CENTER

GALLEY LIGHTS – FAULT CODES

EFFECTIVITY

ALL

33-FAULT CODE DIAGRAM

08

Page 21
Aug 10/98

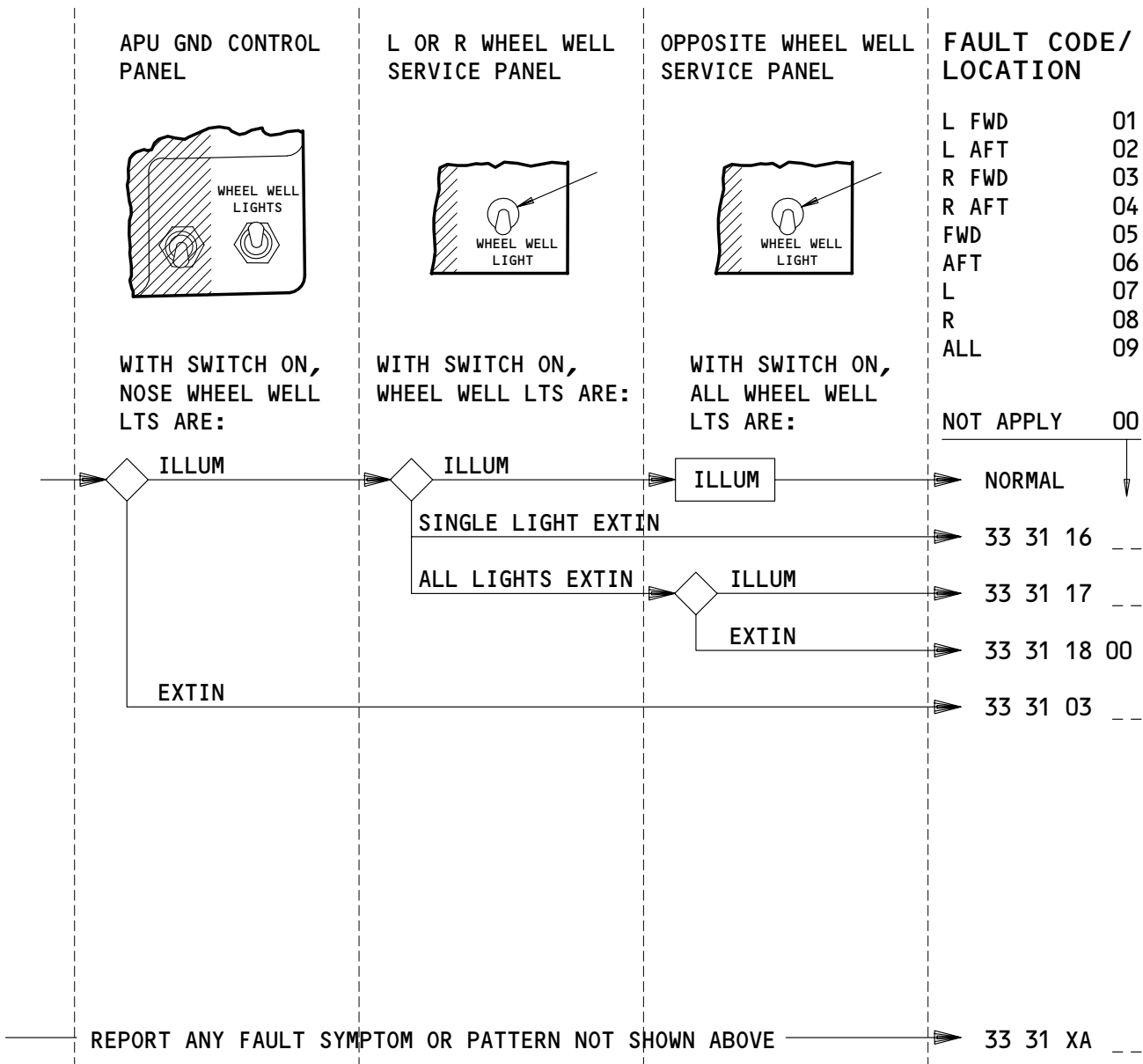

APPLICABLE CIRCUIT BREAKERS

FWD EQUIPMENT CENTER

WHEEL WELL LIGHTS - FAULT CODES

EFFECTIVITY

ALL

33-FAULT CODE DIAGRAM

BOEING

767

FAULT ISOLATION/MAINT MANUAL

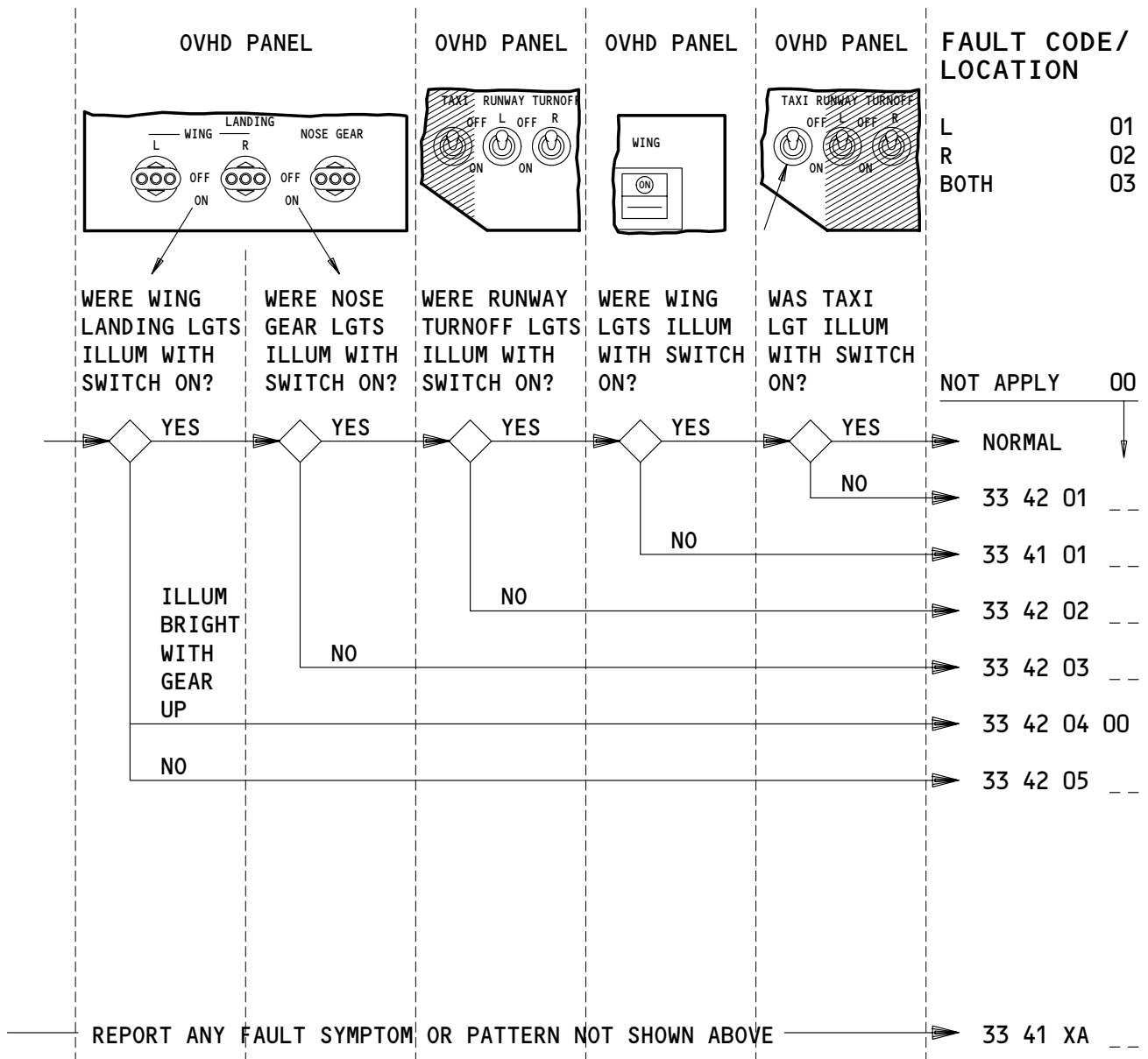

APPLICABLE CIRCUIT BREAKERS

- 11N1 NOSE GEAR CONT
- 11N3 LANDING NOSE GEAR L
- 11N4 LANDING NOSE GEAR R
- 11N5 LANDING WING L
- 11N6 RUNWAY TURNOFF L
- 11N8 TAXI L

- 11N9 TAXI R
- 11N31 LANDING WING DIM CONT
- 11N32 LANDING WING R
- 11N33 RUNWAY TURNOFF R
- 11N35 WING ILLUM

LANDING, RUNWAY TURNOFF, WING AND TAXI LIGHTS - FAULT CODES

EFFECTIVITY

ALL

33-FAULT CODE DIAGRAM

48919

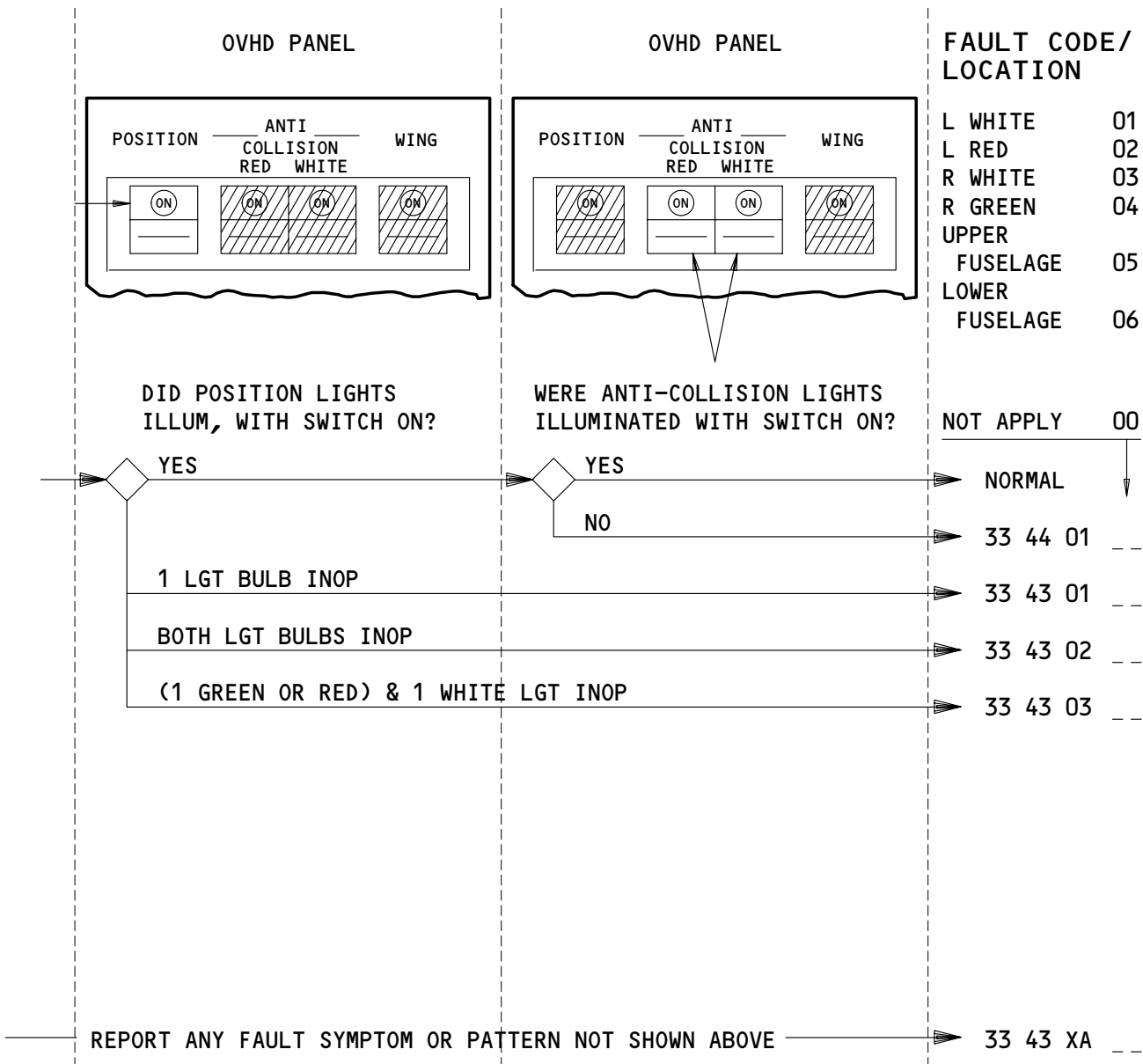

APPLICABLE CIRCUIT BREAKERS

11N7	ANTI COLL WHITE	11S28	POSITION L
11N34	ANTI COLL RED	11S30	POSITION R

POSITION AND ANTI-COLLISION LIGHTS - FAULT CODES

EFFECTIVITY

ALL

33-FAULT CODE DIAGRAM

Not Used
Figure 24

EFFECTIVITY

ALL

33-FAULT CODE DIAGRAM

06

Page 25
Aug 10/98

BOEING

767

FAULT ISOLATION/MAINT MANUAL

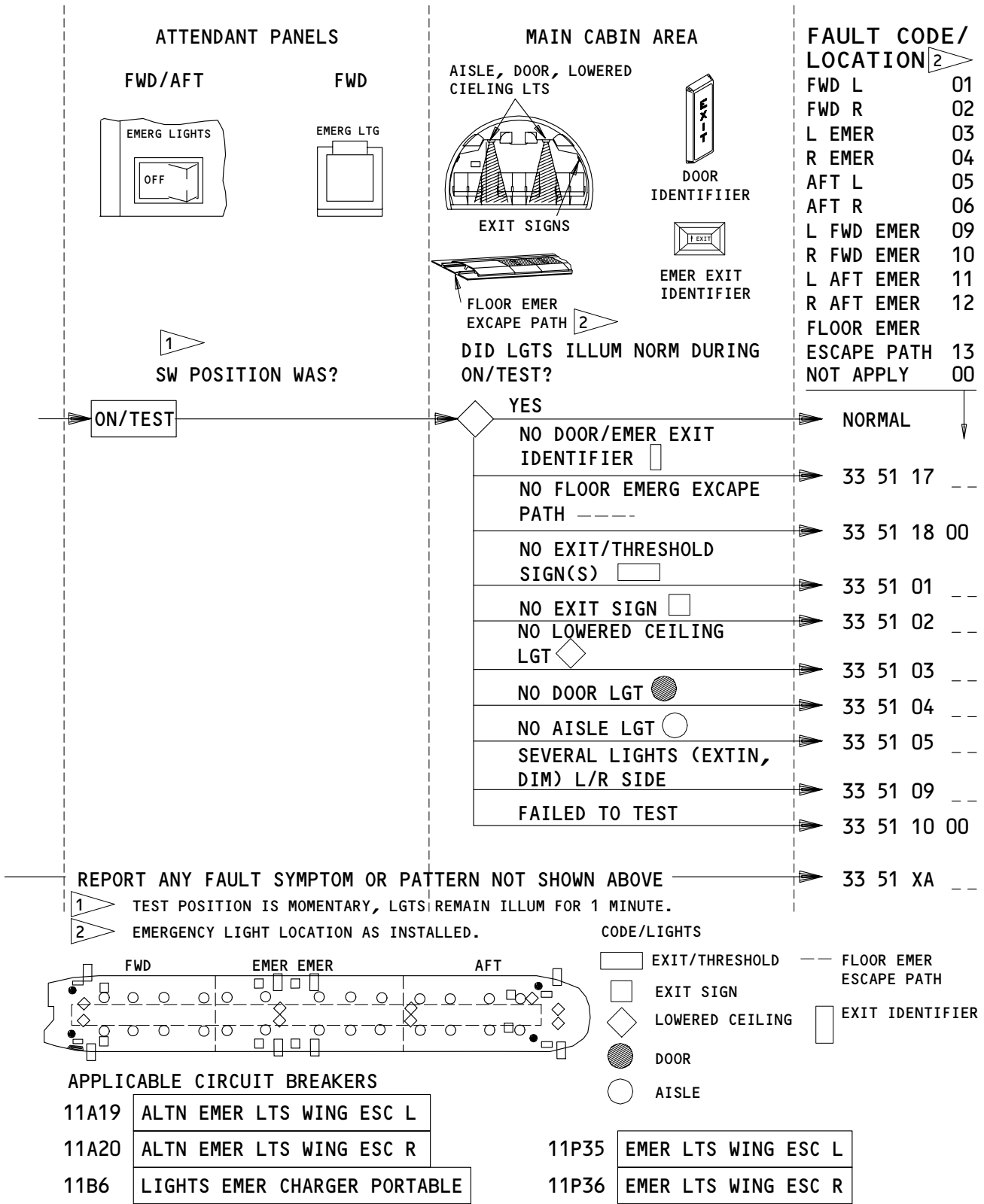

EMERGENCY LIGHTS INTERIOR (ATTND PNL SW) - FAULT CODES

EFFECTIVITY

ALL

33-FAULT CODE DIAGRAM

BOEING
767
FAULT ISOLATION/MAINT MANUAL

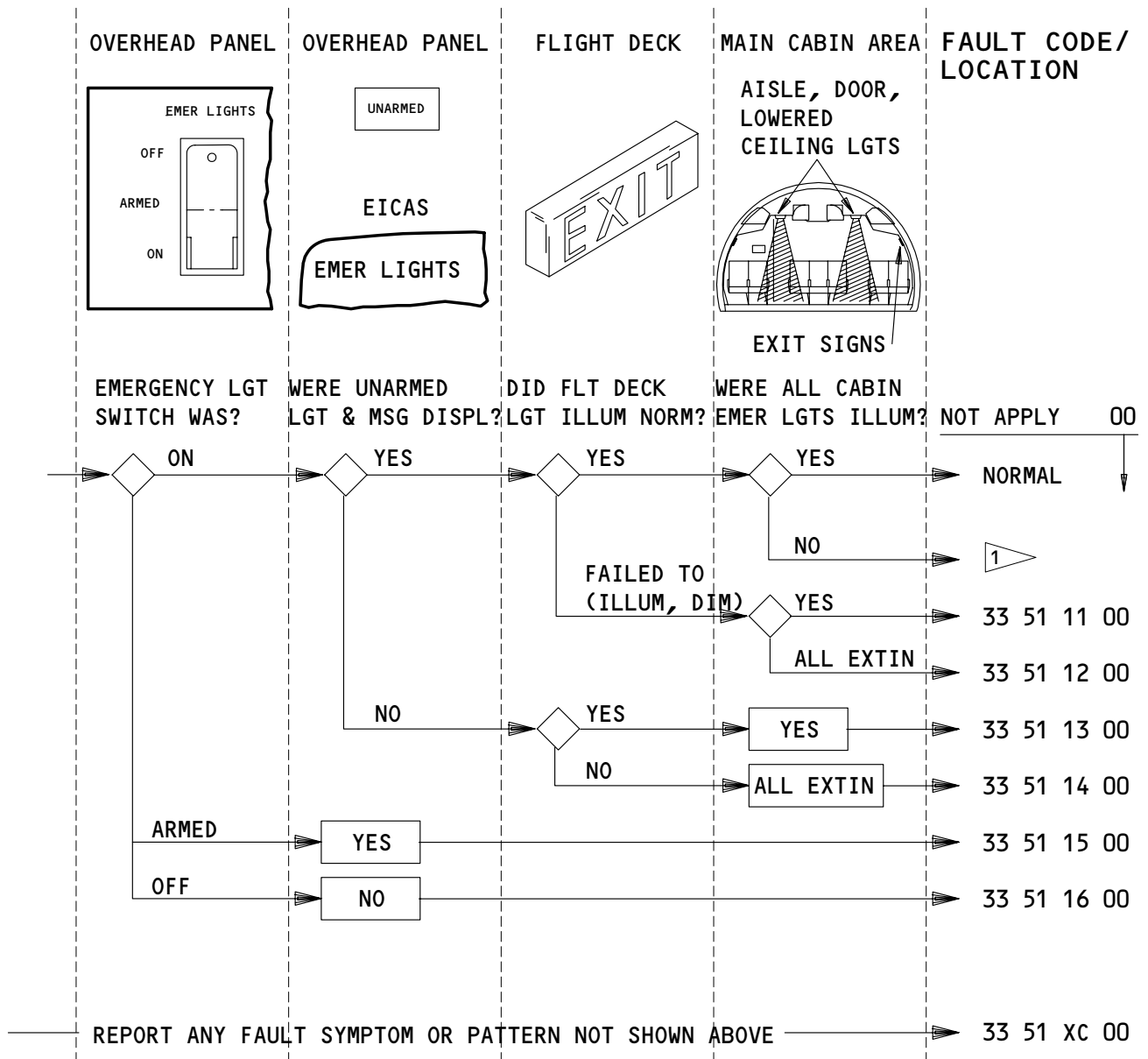

1 SEE "EMERGENCY LIGHTS INTERIOR (ATTND PNL SW)" FAULT CODES.

APPLICABLE CIRCUIT BREAKERS

11A19	ALTN EMER LTS WING ESC L
11A20	ALTN EMER LTS WING ESC R
11B6	LIGHTS EMER CHARGER PORTABLE
11P35	EMER LTS WING ESC L
11P36	EMER LTS WING ESC R

EMERGENCY LIGHTS INTERIOR (OVHD PNL SW) - FAULT CODES

EFFECTIVITY

ALL

33-FAULT CODE DIAGRAM

BOEING
767
FAULT ISOLATION/MAINT MANUAL

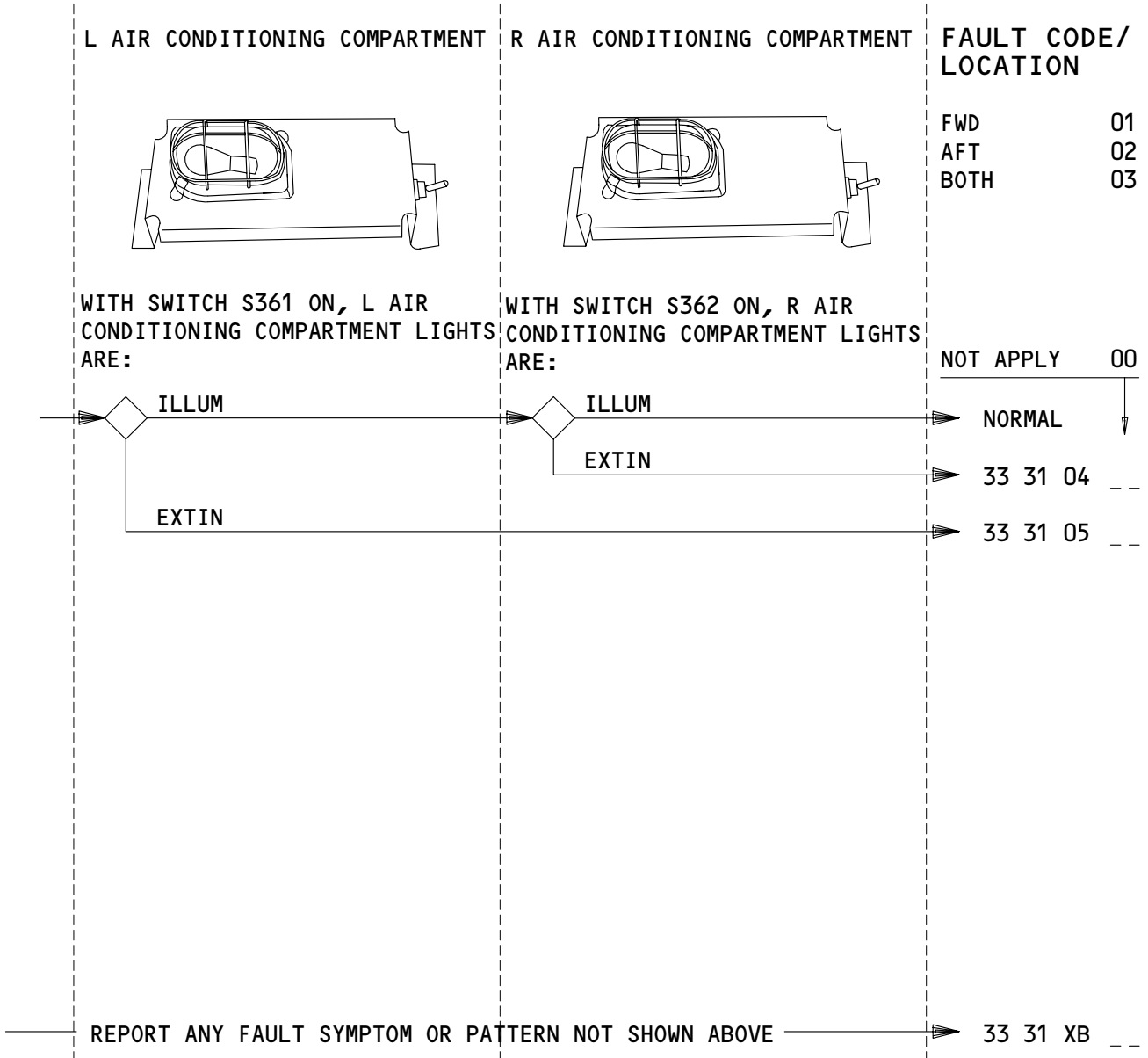

APPLICABLE CIRCUIT BREAKERS

34S2 LIGHTS AIR COND COMPT

AIR CONDITIONING COMPARTMENT LIGHTS - FAULT CODES (GROUND)

EFFECTIVITY

ALL

33-FAULT CODE DIAGRAM

02

Page 28
May 10/88

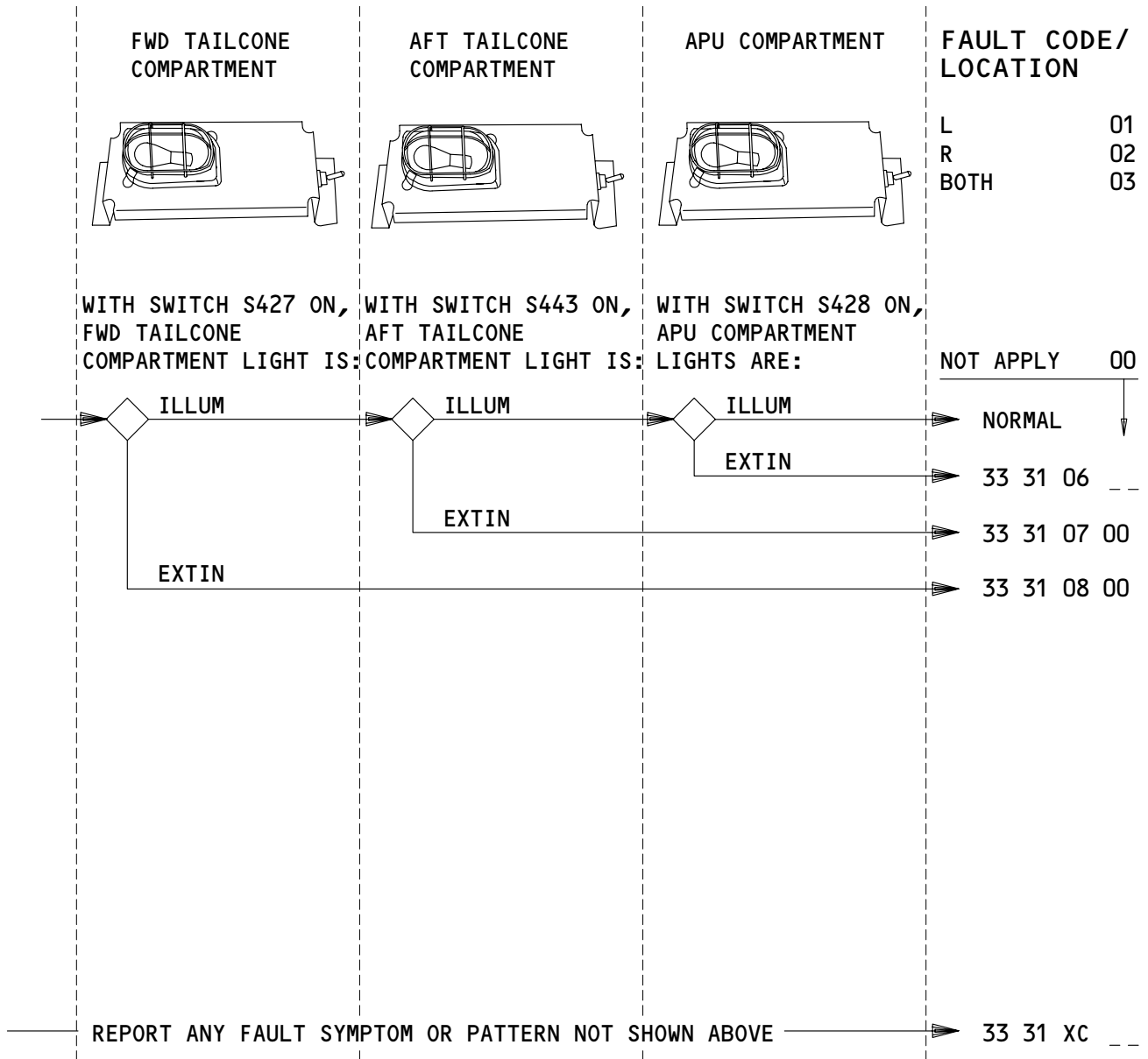

APPLICABLE CIRCUIT BREAKERS

34S3 LIGHTS APU/TAIL COMPT

APU & TAILCONE COMPARTMENT LIGHTS - FAULT CODES (GROUND)

EFFECTIVITY

ALL

33-FAULT CODE DIAGRAM

BOEING

767

FAULT ISOLATION/MAINT MANUAL

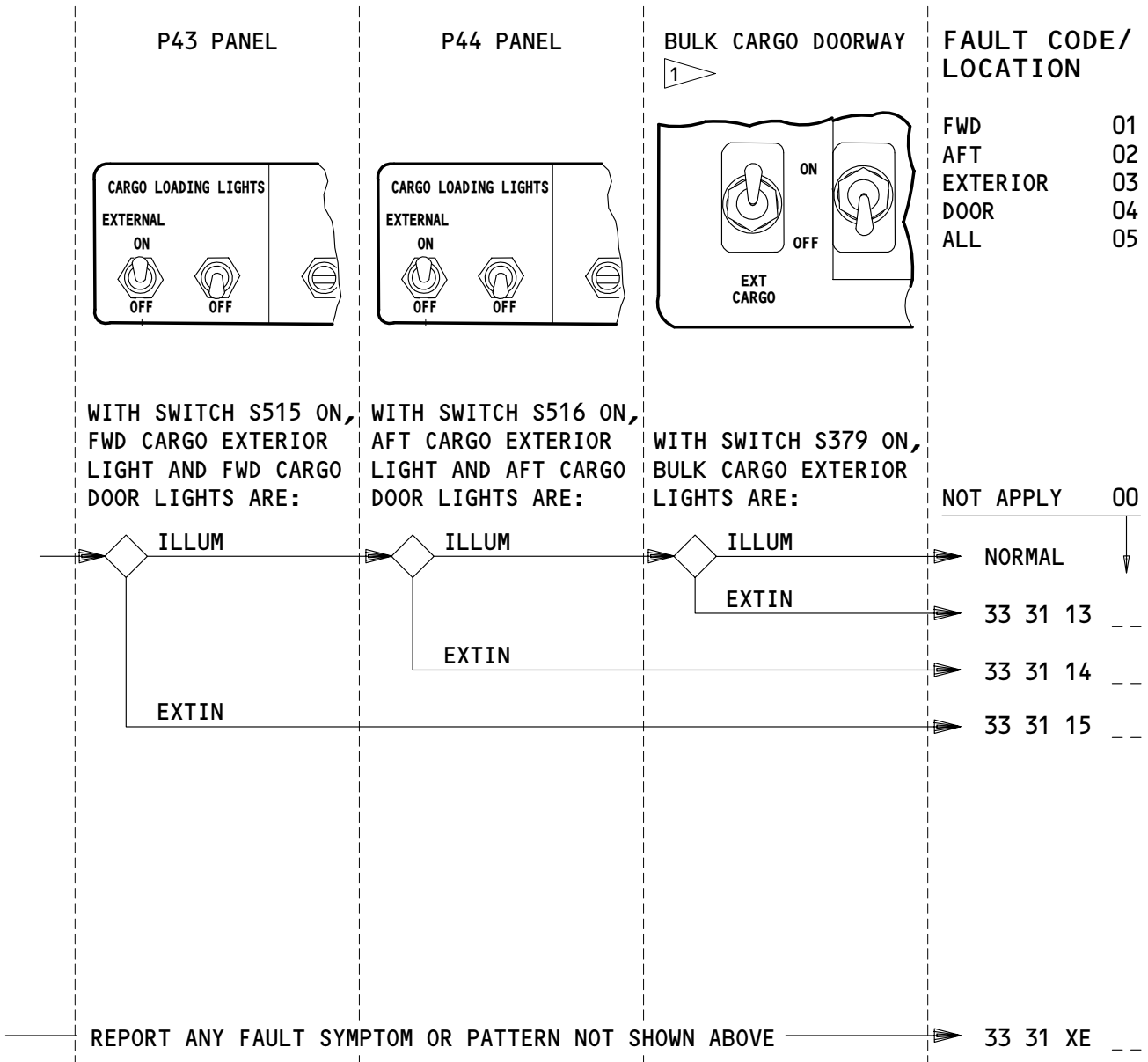

APPLICABLE CIRCUIT BREAKERS

34J2	CONT FWD CARGO HDLG	35D9	LIGHTS EXTERIOR
34J3	CONT AFT CARGO HDLG	39D6	LIGHTS DOOR AREA
35D6	LIGHTS DOOR AREA	39D7	LIGHTS CARGO AREA
35D7	LIGHTS CARGO AREA	39D8	LIGHTS EXTERIOR BULK 1
35D8	LIGHTS EXTERIOR	39D9	LIGHTS EXTERIOR AFT 1
		39D9	LIGHTS EXTERIOR 2

1 ALL SAS AIRPLANES
 2 ALL MTH AIRPLANES

CARGO LOAD EXTERIOR LIGHTS - FAULT CODES (GROUND)

EFFECTIVITY

ALL

33-FAULT CODE DIAGRAM

09

Page 30
Aug 10/98

BOEING
767
FAULT ISOLATION/MAINT MANUAL

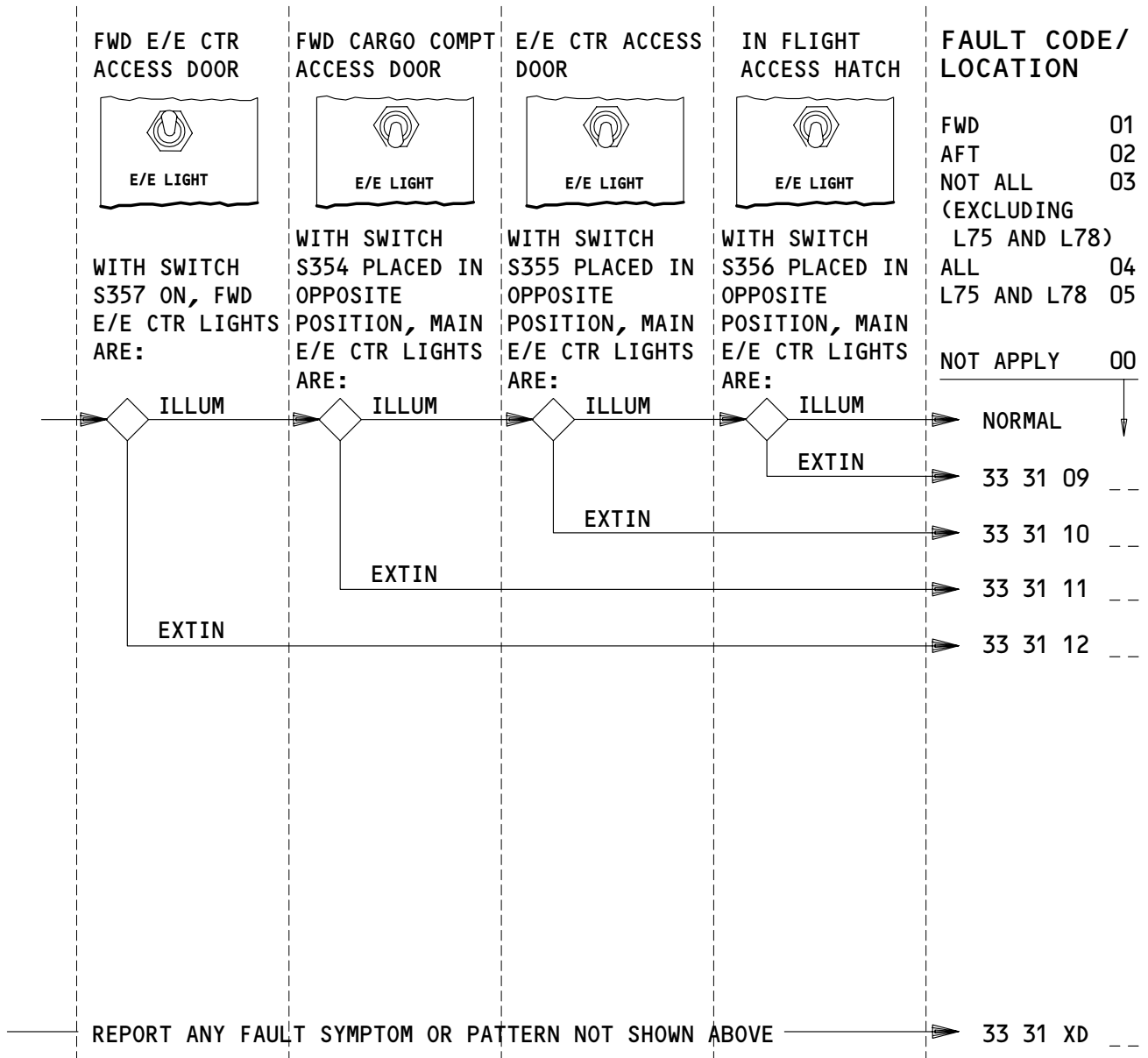

APPLICABLE CIRCUIT BREAKERS

33K6 LIGHTS ELEC EQUIP CTR

ELECTRICAL EQUIPMENT CENTER LIGHTS – FAULT CODES (GROUND)

EFFECTIVITY

ALL

33-FAULT CODE DIAGRAM

09

Page 31
Aug 10/98

BOEING
767
FAULT ISOLATION/MAINT MANUAL

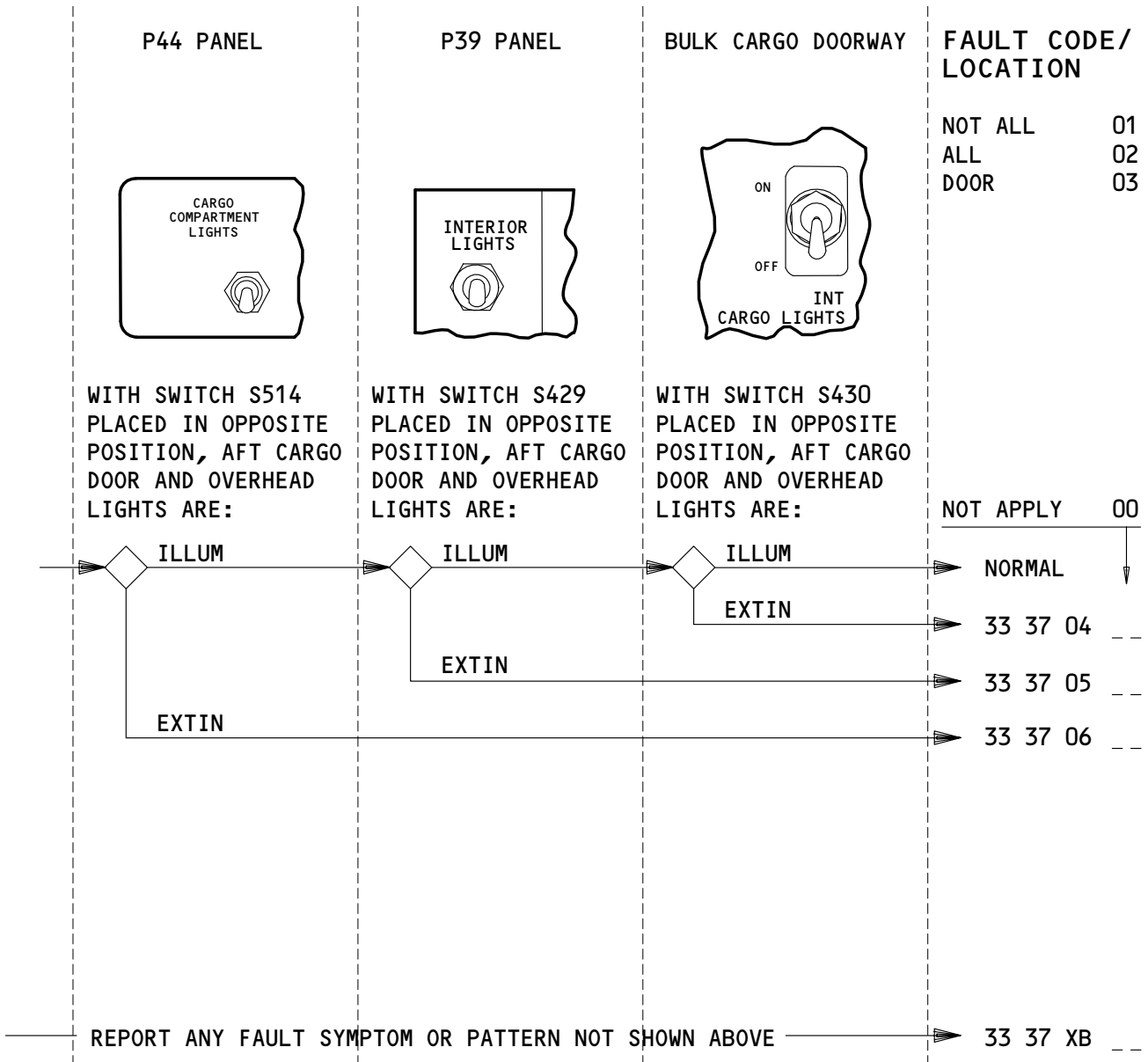

APPLICABLE CIRCUIT BREAKERS

34J3	CONT AFT CARGO HDLG
34S11	LIGHTS AFT COMPT
39D3	LIGHTS COMPT A
39D4	LIGHTS COMPT B
39D5	LIGHTS DOOR SILL

AFT CARGO COMPARTMENT LIGHTS - FAULT CODES (GROUND)

EFFECTIVITY

ALL

33-FAULT CODE DIAGRAM

01

Page 32
Aug 10/98

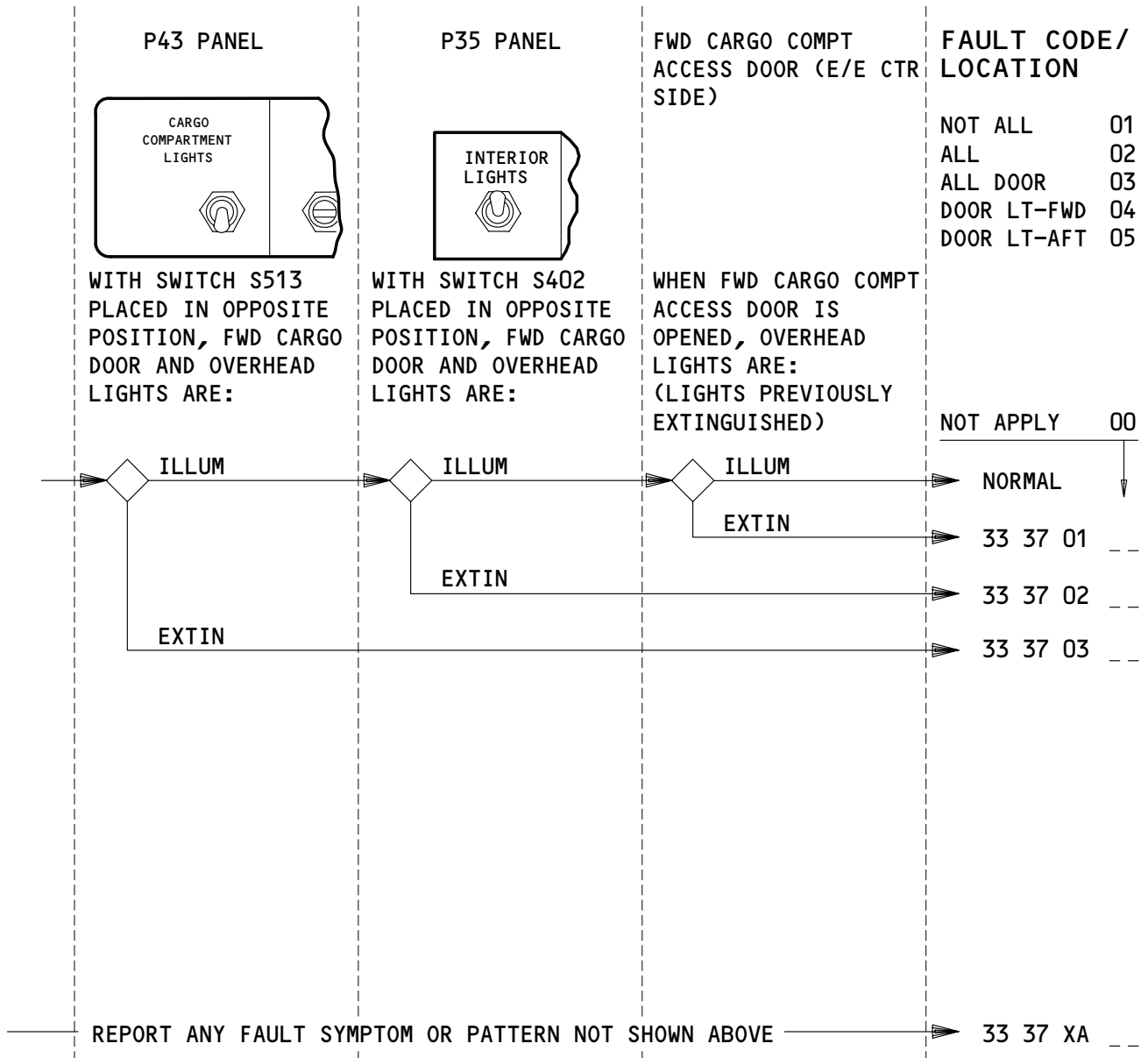

APPLICABLE CIRCUIT BREAKERS

34J2	CONT FWD CARGO HDLG
34S10	LIGHTS FWD CARGO
35D3	LIGHTS COMPT A
35D4	LIGHTS COMPT B
35D5	LIGHTS DOOR SILL

FWD CARGO COMPARTMENT LIGHTS - FAULT CODES (GROUND)

EFFECTIVITY

ALL

33-FAULT CODE DIAGRAM

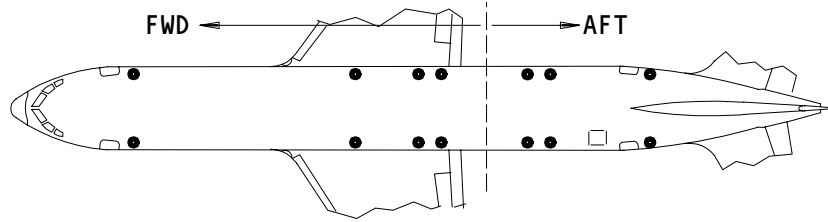

**FAULT CODE/
LOCATION**

FWD 01
AFT 02
ALL 03

APU SHUTDOWN
PANEL

EMER EXIT
LT TEST

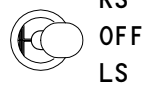

EXTERIOR EMER
LTS ARE:
ILLUM

PASSENGER CABIN
DOOR OPEN &
ARMED ALL EXTERIOR
EMER LTS ON DOOR
SIDE ARE:

NOT APPLY 00

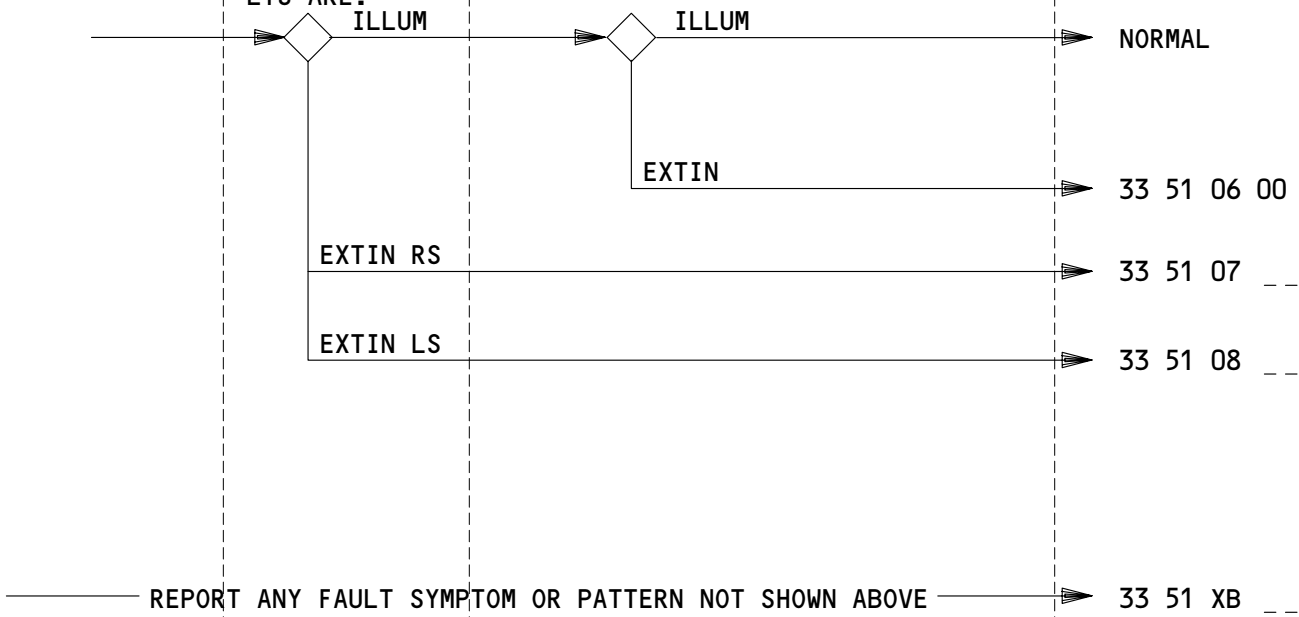

APPLICABLE CIRCUIT BREAKERS

11A19	EMER LTS/OFF WG ESC ALT L
11A20	EMER LTS/OFF WG ESC ALT R

11P35	EMER LTS/OFF WG ESC L
11P36	EMER LTS/OFF WG ESC R

EXTERIOR EMERGENCY LIGHTS TEST - FAULT CODES (GROUND)

EFFECTIVITY	ALL
-------------	-----

33-FAULT CODE DIAGRAM

BOEING
 767
 FAULT ISOLATION/MAINT MANUAL

FAULT CODE	1. LOG BOOK REPORT 2. FAULT ISOLATION REFERENCE
33 11 XA 00	1. A floodlight problem was encountered by the flight crew which is not covered in the fault code diagram (Ref fault code diagram for flight crew action). 2. SSM 33-11-01
33 11 XB --	1. A (01=Capt, 02=F/O, 03=aft flt dk) dome light problem was encountered by the flight crew which is not covered in the fault code diagram (Ref fault code diagram for flight crew action). 2. SSM 33-11-02
33 13 XA 00	1. A pilots instrument/misc panel lighting problem was encountered by the flight crew which is not covered in the fault code diagram (Ref fault code diagram for flight crew action). 2. SSM 33-13-01
33 13 XB 00	1. An overhead, glareshield, aisle stand and supernumerary panel lights problem was encountered by the flight crew which is not covered in the fault code diagram (Ref fault code diagram for flight crew action). 2. SSM 33-13-01
33 14 XA --	1. A (01=Capt, 02=F/O, 04=1st obs, 05=2nd obs) map, chart, or flight kit/utility light problem was encountered by the flight crew which is not covered in the fault code diagram (Ref fault code diagram for flight crew action). 2. SSM 33-14-01
33 16 XA 00	1. A miscellaneous bulbs/master dim and test problem was encountered by the flight crew which is not covered in the fault code diagram (Ref fault code diagram for flight crew action). 2. SSM 33-16-01
33 21 XA 00	1. An indirect ceiling light problem was encountered by the flight crew which is not covered in the fault code diagram (Ref fault code diagram for flight crew action). 2. SSM 33-21-01

EFFECTIVITY

ALL

33-FAULT CODE INDEX

BOEING
 767
 FAULT ISOLATION/MAINT MANUAL

FAULT CODE	1. LOG BOOK REPORT 2. FAULT ISOLATION REFERENCE
33 21 XC 00	1. A sidewall washlight problem was encountered by the flight crew which is not covered in the fault code diagram (Ref fault code diagram for flight crew action). 2. SSM 33-21-03
33 22 XA 00	1. A forward direct ceiling lights problem was encountered by the flight crew which is not covered in the fault code diagram (Ref fault code diagram for flight crew action). 2. SSM 33-22-02
33 22 XB --	Not Used
33 22 XC --	1. A (01=fwd L entry ceiling, 02=fwd L entry, 03=fwd R entry, 04=aft L, 05=aft R) threshold entry lights problem was encountered by the flight crew which is not covered in the fault code diagram (Ref fault code diagram for flight crew action). 2. SSM 33-22-01
33 22 XD 00	1. A closet light problem was encountered by the flight crew which is not covered in the fault code diagram (Ref fault code diagram for flight crew action). 2. SSM 33-22-01
33 22 XE --	1. A (01=L, 02=R, 03=C) attendant's work lights problem was encountered by the flight crew which is not covered in the fault code diagram (Ref fault code diagram for flight crew action). 2. SSM 33-22-01
33 22 XF --	Not Used
33 22 XG --	1. A (01=aft lavatory, 02=aft galley) aft direct ceiling lights problem was encountered by the flight crew which is not covered in the fault code diagram (Ref fault code diagram for flight crew action). 2. SSM 33-22-02
33 24 XA 00	1. A no smoking light problem was encountered by the flight crew which is not covered in the fault code diagram (Ref fault code diagram for flight crew action). 2. SSM 33-24-01

EFFECTIVITY

ALL

33-FAULT CODE INDEX

BOEING
 767
 FAULT ISOLATION/MAINT MANUAL

FAULT CODE	1. LOG BOOK REPORT 2. FAULT ISOLATION REFERENCE
33 24 XB 00	1. A seatbelts/return to seat light problem was encountered by the flight crew which is not covered in the fault code diagram (Ref fault code diagram for flight crew action). 2. SSM 33-24-01
33 25 XA --	1. A (01=A, 02=B, 03=C, 04=D, 05=E, 06=F, 08=fwd L, 09=fwd R, 10=mid L, 11=mid R, 12=mid ctr L, 13=mid ctr R, 14=mid aft L, 15=mid aft R, 16=aft L, 17=aft R, 18=all) lavatory attendant call problem was encountered by the flight crew which is not covered in the fault code diagram (Ref Chapter 23 fault code diagram for flight crew action). 2. SSM 33-25-01
33 25 XB --	1. A (01=F-1, 02=MC-F, 03=MS-LF, 04=MS-RF, 05=MC-A, 06=MS-LA, 07=MS-RA, 08=fwd L, 09=fwd R, 10=mid fwd L, 11=mid fwd R, 12=mid L, 13=mid R, 14=mid ctr L, 15=mid ctr R, 16=mid aft L, 17=mid aft R, 18=aft L, 19=aft R, 20=purser) lavatory attendant call problem was encountered by the flight crew which is not covered in the fault code diagram (Ref Chapter 23 fault code diagram for flight crew action). 2. SSM 33-25-01
33 26 XA --	1. A (01=F-1, 02=MS-LF, 03=MC-F, 04=MS-RF, 05=MS-LA, 06=MC-A, 07=MS-RA) lavatory lights problem was encountered by the flight crew which is not covered in the fault code diagram (Ref fault code diagram for flight crew action). 2. SSM 33-26-01, SSM 33-26-02
33 26 XB --	1. A (01=A, 02=B, 03=C, 04=D, 05=E, 06=F) lavatory lights problem was encountered by the flight crew which is not covered in the fault code diagram (Ref fault code diagram for flight crew action). 2. SSM 33-26-01, SSM 33-26-02
33 27 XA 00	1. A galley lights problem was encountered by the flight crew which is not covered in the fault code diagram (Ref fault code diagram for flight crew action). 2. SSM 33-27-01

EFFECTIVITY

ALL

33-FAULT CODE INDEX

BOEING
 767
 FAULT ISOLATION/MAINT MANUAL

FAULT CODE	1. LOG BOOK REPORT 2. FAULT ISOLATION REFERENCE
33 31 XA --	1. A (01=L fwd, 02=L aft, 03=R fwd, 04=R aft, 05=fwd, 06=aft, 07=L, 08=R, 09=all) wheel well light problem was encountered by the flight crew which is not covered in the fault code diagram (Ref fault code diagram for flight crew action). 2. SSM 33-31-01
33 31 XC --	1. A (01=L, 02=R, 03=both) APU or tailcone compartment lights problem was encountered on ground which is not covered in the fault code diagram (Ref GROUND fault code diagram for flight crew action). 2. SSM 33-31-02
33 31 XD --	1. A (01=fwd, 02=aft, 03=not all, 04=all, 05=L75 and L78) electrical equipment center lights problem was encountered on ground which is not covered in the fault code diagram (Ref GROUND fault code diagram for flight crew action). 2. SSM 33-31-03
33 31 XE --	1. A (01=fwd, 02=aft, 03=exterior, 04=door, 05=all) cargo load exterior lights problem was encountered on ground which is not covered in the fault code diagram (Ref GROUND fault code diagram for flight crew action). 2. SSM 33-31-04
33 37 XA --	1. A (01=not all, 02=all, 03=all door, 04=door 1t-fwd, 05=door 1t-aft) fwd cargo compartment lights problem was encountered on ground which is not covered in the fault code diagram (Ref GROUND fault code diagram for flight crew action). 2. SSM 33-37-01

EFFECTIVITY

ALL

33-FAULT CODE INDEX

BOEING
 767
 FAULT ISOLATION/MAINT MANUAL

FAULT CODE	1. LOG BOOK REPORT 2. FAULT ISOLATION REFERENCE
33 37 XB --	1. A (01=not all, 02=all, 03=door) aft cargo compartment lights problem was encountered on ground which is not covered in the fault code diagram (Ref GROUND fault code diagram for flight crew action). 2. SSM 33-37-02
33 41 XA --	1. A (01=L, 02=R, 03=both) landing, runway turnoff, wing, or taxi lights problem was encountered by the flight crew which is not covered in the fault code diagram (Ref fault code diagram for flight crew action). 2. SSM 33-41-01, SSM 33-42-01, and SSM 33-42-02
33 43 XA --	1. A (01=L white, 02=L red, 03=R white, 04=R green, 05=upper fuselage, 06=lower fuselage) position/anti-collision light problem was encountered by the flight crew which is not covered in the fault code diagram (Ref fault code diagram for flight crew action). 2. SSM 33-43-01 and SSM 33-44-01
33 45 XA --	1. A (01=L inbd, 02=L outbd, 03=R inbd, 04=R outbd, 05=LH, 06=RH) logo lights problem was encountered by the flight crew which is not covered in the fault code diagram (Ref fault code diagram for flight crew action). 2. SSM 33-45-01
33 51 XA --	1. A (02=fwd L, 03=fwd R, 04=mid, 05=mid L, 06=mid R, 08=aft L, 09=aft R, 10=L emer, 11=R emer, 12=floor emer escape path) emergency lights interior (attnd pnl sw) problem was encountered by the flight crew which is not covered in the fault code diagram (Ref fault code diagram for flight crew action). 2. SSM 33-51-01
33 51 XB --	1. A (01=fwd, 02=aft, 03=all) exterior emergency light problem was encountered on ground which is not covered in the fault code diagram (Ref GROUND fault code diagram for flight crew action). 2. SSM 33-51-01

EFFECTIVITY

ALL

33-FAULT CODE INDEX

20

Page 5
May 10/96

BOEING
 767
 FAULT ISOLATION/MAINT MANUAL

FAULT CODE	1. LOG BOOK REPORT 2. FAULT ISOLATION REFERENCE
33 51 XC 00	1. A emergency lights interior (ovhd pnl sw) problem was encountered by the flight crew which is not covered in the fault code diagram (Ref fault code diagram for flight crew action). 2. SSM 33-51-01
33 11 01 00	1. F/O's inst pnl floodlight control will not illum or control intensity of lgts. Lgts illum brt with lgt ovrd switch ON. 2. Replace F/O panel floodlight control potentiometer R508 (WDM 33-11-11).
33 11 02 00	1. F/O's inst pnl floodlight control will not illum or control intensity of lgts. Lgts do not illum brt with lgt ovrd switch ON. 2. Relamp F/O instrument panel floodlight L51 (AMM 33-11-00). If fault persists, replace F/O panel floodlight dimmer control unit M506 (AMM 33-11-03).
33 11 03 00	1. Aisle stand floodlight control will not illum or control intensity of lgts. Lgts illum brt with lgt ovrd switch ON. 2. Replace left lighting control panel M10056 (PANEL/FLOOD AISLE STAND control YCWR2 is faulty) (WDM 33-11-13).
33 11 04 00	1. Aisle stand floodlight control will not illum or control intensity of lgts. Lgts do not illum brt with lgt ovrd switch ON. 2. Relamp aisle stand floodlight L707 (AMM 33-11-00).
33 11 05 00	1. Glareshield floodlight control will not illum or control intensity of lgts. Lgts illum brt with lgt ovrd switch ON. 2. Replace left lighting control panel M10056 (PANEL/FLOOD GLARESHIELD control YCWR1 is faulty) (WDM 33-11-13).
33 11 06 00	1. Glareshield floodlight control will not illum or control intensity of lgts. Lgts do not illum brt with lgt ovrd switch ON. 2. Replace glareshield floodlight dimmer control unit M843 (AMM 33-11-03).
33 11 07 00	1. Capt & ctr inst pnl floodlight control will not illum or control intensity of (captain's inst pnl, center inst pnl) lgts. Lgts illum brt with lgt ovrd switch ON. 2. Replace Capt & ctr panel floodlight control potentiometer R507 (WDM 33-11-11).

EFFECTIVITY

ALL

33-FAULT CODE INDEX

BOEING
 767
 FAULT ISOLATION/MAINT MANUAL

FAULT CODE	1. LOG BOOK REPORT 2. FAULT ISOLATION REFERENCE
33 11 08 00	1. Capt & ctr inst pnl floodlight control will not illum or control intensity of lgts. Lgts do not illum brt with lgt ovrd sw ON. 2. Replace Capt & ctr panel floodlights dimmer control unit M505 (AMM 33-11-03).
33 11 09 --	Not Used
33 11 10 --	Not Used
33 11 11 00	1. CAPT, F/O & aft flight deck dome light would not illuminate using dome light switch but illuminate brightly with light override switch ON. 2. Replace right lighting control panel M10057 (DOME control YCXT1 is faulty) (WDM 33-11-14).
33 11 12 --	1. (01=Capt, 02=F/O, 03=Aft flt dk) dome lgt would not illum using dome lgt switch or with lgt ovrd switch ON. 2. Relamp Capt (F/O, aft flight deck) dome light L38 (L39, L47) (AMM 33-11-00).
33 11 13 00	1. Capt, F/O & aft flt dk dome lgt intensity could not be controlled with dome lgt switch. 2. Replace right lighting control panel M10057 (DOME control YCXT1 is faulty) (WDM 33-11-14). If fault persists, replace flood, dome & MD&T override relay K749 (WDM 33-11-14).
33 11 14 00	1. F/O's inst pnl floodlight control will not control intensity of lgts. Lgts remain dim with lgt ovrd sw on. 2. Replace F/O panel floodlight dimmer control unit M506 (AMM 33-11-03). If fault persists, perform FIM 33-11-00/101, Fig. 103, Block 1.
33 11 15 00	1. F/O's inst pnl floodlight control will not control intensity of lgts. Lgts remain dim with control off. 2. Replace F/O floodlight standby power relay K744 (WDM 33-11-11). If fault persists, perform FIM 33-11-00/101, Fig. 103, Block 1.
33 11 16 00	1. Aisle stand floodlight control will not control intensity of lgt. Lgt remains dim with control off. 2. Replace standby light control relay K728 (WDM 33-11-13). If fault persists, replace left lighting control panel M10056 (PANEL/FLOOD AISLE STAND control YCWR2 is faulty) (WDM 33-11-13).

EFFECTIVITY

ALL

33-FAULT CODE INDEX

BOEING
 767
 FAULT ISOLATION/MAINT MANUAL

FAULT CODE	1. LOG BOOK REPORT 2. FAULT ISOLATION REFERENCE
33 11 17 00	1. Capt & ctr inst pnl floodlight control will not control intensity of lgts. Lgts remain dim with lgt ovrd sw on. 2. Replace Capt & ctr panel floodlights dimmer control unit M505 (AMM 33-11-03). If fault persists, perform FIM 33-11-00/101, Fig. 103, Block 1.
33 11 18 00	1. Capt & ctr inst pnl floodlight control will not control intensity of lgts. Lgts remain dim with control off. 2. Replace Capt floodlight standby power relay K743 (WDM 33-11-11). If fault persists, perform FIM 33-11-00/101, Fig. 103, Block 1.
33 11 19 -- thru 33 11 22 --	Not Used
33 11 23 00	1. F/O's inst pnl floodlight flickers. 2. Relamp F/O instrument panel floodlight L51 (AMM 33-11-00). If fault persists, replace F/O panel floodlight dimmer control unit M506 (AMM 33-11-03).
33 11 24 00	1. Aisle stand floodlight flickers. 2. Replace left lighting control panel M10056 (PANEL/FLOOD AISLE STAND control YCWR2 is faulty) (WDM 33-11-13).
33 11 25 00	1. Glareshield floodlight flickers. 2. Replace glareshield floodlight dimmer control unit M843 (AMM 33-11-03). If fault persists, replace left lighting control panel M10056 (PANEL/FLOOD GLARESHIELD control YCWR1 is faulty) (WDM 33-11-13).
33 11 26 00	1. Capt & ctr inst pnl floodlights flicker. 2. Relamp Capt (Ctr) instrument panel floodlight L49 (L50) (AMM 33-11-00). If fault persists, replace Capt & ctr panel floodlights dimmer control unit M505 (AMM 33-11-03).
33 13 01 -- thru 33 13 08 --	Not Used
33 13 09 00	1. F/O inst and panel lgt dimmer control inop. 2. FIM 33-13-00/101, Fig. 104, Block 1

EFFECTIVITY

ALL

33-FAULT CODE INDEX

03

Page 8
May 10/96



BOEING
767
FAULT ISOLATION/MAINT MANUAL

FAULT CODE	1. LOG BOOK REPORT 2. FAULT ISOLATION REFERENCE
33 13 10 00	1. F/O inst panel (state location) lgt extin. 2. (For Pushbutton Switch/lights) Relamp switch/light (AMM 33-13-00). If fault persists, replace diode/fuse card (AMM 33-13-00). If fault persists, replace switch/light (AMM 33-13-00). (For Lightplates) Replace lightplate (AMM 33-13-01). (For Instrument Lights) Relamp instrument light (AMM 33-13-03). (For Lights Not Specifically Covered Above) Relamp or replace light as necessary (WDM 33-13-13).
33 13 11 00	1. Capt inst pnl and foot/shoulder heater panel dimmer control inop. 2. Replace Capt instrument & panel lights dimmer control unit M788 (AMM 33-13-02).
33 13 12 00	1. Center inst panel dimmer control inop. 2. Replace pilots ctr instrument panel dimmer control unit M790 (AMM 33-13-02).
33 13 13 00	1. Capt inst panel (state location) lgt extin. 2. (For Pushbutton Switch/lights) Relamp switch/light (AMM 33-13-00). If fault persists, replace diode/fuse card (AMM 33-13-00). If fault persists, replace switch/light (AMM 33-13-00). (For Lightplates) Replace lightplate (AMM 33-13-01). (For Instrument Lights) Relamp instrument light (AMM 33-13-03). (For Lights Not Specifically Covered Above) Relamp or replace light as necessary (WDM 33-13-11).
33 13 14 00	1. Aisle stand panel lgts dimmer control inop. 2. FIM 33-13-00/101, Fig. 107, Block 1
33 13 15 00	1. Aisle stand panel lgt (state location) extin. 2. (For Pushbutton Switch/lights) Relamp switch/light (AMM 33-13-00). If fault persists, replace diode/fuse card (AMM 33-13-00). If fault persists, replace switch/light (AMM 33-13-00). (For Lightplates) Replace lightplate (AMM 33-13-01). (For Instrument Lights) Relamp instrument light (AMM 33-13-03). (For Lights Not Specifically Covered Above) Relamp or replace light as necessary (WDM 33-13-18).

EFFECTIVITY

ALL

33-FAULT CODE INDEX

03

Page 9
May 10/96

BOEING
 767
 FAULT ISOLATION/MAINT MANUAL

FAULT CODE	1. LOG BOOK REPORT 2. FAULT ISOLATION REFERENCE
33 13 16 00	1. Glareshield panel lgts dimmer control inop. 2. FIM 33-13-00/101, Fig. 106, Block 1
33 13 17 00	1. Glareshield panel lgt (state location) extin. 2. (For Pushbutton Switch/lights) Relamp switch/light (AMM 33-13-00). If fault persists, replace diode/fuse card (AMM 33-13-00). If fault persists, replace switch/light (AMM 33-13-00). (For Lightplates) Replace lightplate (AMM 33-13-01). (For Instrument Lights) Relamp instrument light (AMM 33-13-03). (For Lights Not Specifically Covered Above) Relamp or replace light as necessary (WDM 33-13-17).
33 13 18 00	1. Overhead panel lgts dimmer control inop. 2. FIM 33-13-00/101, Fig. 105, Block 1
33 13 19 00	1. Overhead panel lgt (state location) extin. 2. (For Pushbutton Switch/lights) Relamp switch/light (AMM 33-13-00). If fault persists, replace diode/fuse card (AMM 33-13-00). If fault persists, replace switch/light (AMM 33-13-00). (For Lightplates) Replace lightplate (AMM 33-13-01). (For Instrument Lights) Relamp instrument light (AMM 33-13-03). (For Lights Not Specifically Covered Above) Relamp or replace light as necessary (WDM 33-13-19).
33 13 20 00	1. Overhead CB panel lgts dimmer control inop. 2. FIM 33-13-00/101, Fig. 107, Block 1
33 13 21 00	1. Overhead CB panel lgt (state location) extin. 2. Replace lightplate (AMM 33-13-01).
33 13 22 00	1. Supernumerary panel lgts dimmer control inop. 2. Replace right side panel dimmer control unit M1130 (AMM 33-13-02). If fault persists, replace right side obs lighting control panel M1129 (PANEL control YDZR2 is faulty) (WDM 33-13-21).

EFFECTIVITY

ALL

33-FAULT CODE INDEX

07

Page 10
May 10/96

BOEING
 767
 FAULT ISOLATION/MAINT MANUAL

FAULT CODE	1. LOG BOOK REPORT 2. FAULT ISOLATION REFERENCE
33 13 23 00	1. Supernumerary panel lgt (state location) extin. 2. (For Pushbutton Switch/lights) Relamp switch/light (AMM 33-13-00). If fault persists, replace diode/fuse card (AMM 33-13-00). If fault persists, replace switch/light (AMM 33-13-00). (For Lightplates) Replace lightplate (AMM 33-13-01). (For Instrument Lights) Relamp instrument light (AMM 33-13-03). (For Lights Not Specifically Covered Above) Relamp or replace light as necessary (WDM 33-13-21).
33 13 24 -- thru 33 13 26 --	Not Used
33 13 27 00	1. Standby compass lgt extin. 2. Relamp pilots standby magnetic compass N99 (WDM 33-13-11).
33 14 01 --	1. (04=1st obs, 05=2nd obs) utility lgt (inop, blinks, etc). 2. FIM 33-14-00/101, Fig. 105, Block 1
33 14 02 --	1. (01=Capt, 02=F/O) chart lgt (inop, blinks, etc). 2. FIM 33-14-00/101, Fig. 104, Block 1
33 14 03 --	1. (01=Capt, 02=F/O, 04=1st obs) map lgt (inop, blinks, etc). 2. FIM 33-14-00/101, Fig. 103, Block 1
33 14 04 --	Not Used
33 14 05 --	1. (01=Capt, 02=F/O) flight kit lgt (inop, blinks, etc). 2. FIM 33-14-00/101, Fig. 105, Block 1
33 16 01 00	1. Annunciator lgts illum dim with lgt ovrd switch ON. 2. FIM 33-16-00/101, Fig. 103, Block 29
33 16 02 00	1. Single lgt extin with ind lts test switch pressed. (Specify lgt) 2. Relamp annunciator (AMM 33-13-00 for switch/light annunciator, AMM 33-16-02 for annunciator). If fault persists, replace annunciator diode/fuse card (AMM 33-13-00 for switch/light annunciator, AMM 33-16-02 for annunciator). If fault persists, replace annunciator (AMM 33-13-00 for switch/light annunciator, AMM 33-16-02 for annunciator).

EFFECTIVITY

ALL

33-FAULT CODE INDEX

13

Page 11
May 10/96

BOEING
 767
 FAULT ISOLATION/MAINT MANUAL

FAULT CODE	1. LOG BOOK REPORT 2. FAULT ISOLATION REFERENCE
33 16 03 00	1. Multiple lgts extin with ind lts test switch pressed. (Specify inop lts) 2. FIM 33-16-00/101, Fig. 103, Block 20
33 16 04 00	1. Annunciator lgts failed to illum brt with ind lts selector switch in BRT. 2. FIM 33-16-00/101, Fig. 103, Block 1
33 16 05 00	1. With ind lts selector switch in DIM annunciator lgts failed to illum dim. 2. FIM 33-16-00/101, Fig. 103, Block 1
33 16 06 00	1. Single bulb inop in _____. (identify switch, annunciator or other) 2. Relamp annunciator (AMM 33-13-00 for switch/light annunciator, AMM 33-16-02 for annunciator). If fault persists, replace annunciator diode/fuse card (AMM 33-13-00 for switch/light annunciator, AMM 33-16-02 for annunciator). If fault persists, replace annunciator (AMM 33-13-00 for switch/light annunciator, AMM 33-16-02 for annunciator).
33 16 07 00	1. Both bulbs inop in _____. (identify switch, annunciator or other) 2. Relamp annunciator (AMM 33-13-00 for switch/light annunciator, AMM 33-16-02 for annunciator). If fault persists, replace annunciator diode/fuse card (AMM 33-13-00 for switch/light annunciator, AMM 33-16-02 for annunciator). If fault persists, replace annunciator (AMM 33-13-00 for switch/light annunciator, AMM 33-16-02 for annunciator).
33 16 08 00	1. Several lgts (identify) failed to extin. 2. FIM 33-16-00/101, Fig. 103, Block 22
33 21 01 00	1. One or two lights extinguish or flicker (Report by nearest aisle seat no.) 2. FIM 33-21-00/101, Fig. 104, Block 7
33 21 02 00	1. All fwd and mid (fwd) lights extinguish. 2. Replace forward indirect ceiling lights transformer T180.
33 21 03 00	1. All mid and aft inbd lights extinguished. 2. FIM 33-21-00/101, Fig. 104, Block 10
33 21 04 00	1. All mid and aft outbd lights extinguished. 2. FIM 33-21-00/101, Fig. 104, Block 12

EFFECTIVITY

ALL

33-FAULT CODE INDEX

05

Page 12
May 10/96

BOEING
 767
 FAULT ISOLATION/MAINT MANUAL

FAULT CODE	1. LOG BOOK REPORT 2. FAULT ISOLATION REFERENCE
33 21 08 -- thru 33 21 21 --	Not Used
33 21 22 00	1. Single sidewall wash light extinguished or flickers. (Report by nearest seat no.) 2. Relamp extinguished light (AMM 33-21-00)
33 21 23 00	1. Two sidewall wash lights extinguish or flicker. (Report by nearest seat no.) 2. Replace ballast associated to the two extinguished lights (WDM 33-21-31).
33 21 24 00	1. More than two sidewall wash lights extinguished. (Report by area seat nos.) 2. FIM 33-21-00/101, Fig. 106, Block 1
33 21 24 00	1. 767-200 AIRPLANES; More than two sidewall wash lights extinguished. (Report by area seat nos.) 2. FIM 33-21-00/101, Fig. 106, Block 1
33 21 51 00	1. Direct ceiling light(s) extin (report location by nearest seat no.) with aft attendant panel light switch ON. 2. FIM 33-21-00/101.
33 21 52 00	1. Direct ceiling light(s) extin (report location by nearest seat no.) with fwd attendant panel light switch ON. 2. FIM 33-21-00/101.
33 22 03 --	Not Used
33 22 05 --	Not Used
33 22 10 --	1. (04=Aft L, 05=Aft R) entry lgt extin with lgt switch ON. 2. FIM 33-22-00/101, Fig. 104, Block 14
33 22 11 --	1. (01=Fwd L entry ceiling, 02=Fwd L entry, 03=Fwd R entry) lgt extin with lgt switch ON. 2. FIM 33-22-00/101, Fig. 104, Block 1
33 22 12 -- thru 33 22 17 --	Not Used

EFFECTIVITY

ALL

33-FAULT CODE INDEX

20

Page 13
May 10/97

BOEING
 767
 FAULT ISOLATION/MAINT MANUAL

FAULT CODE	1. LOG BOOK REPORT 2. FAULT ISOLATION REFERENCE
33 22 18 --	1. Fwd (01=L, 03=C) attendant's work lgt extin with switch ON. 2. FIM 33-22-00/101, Fig. 105, Block 1
33 22 19 --	Not Used
33 22 20 --	1. Aft (01=L, 02=R, 03=C) attendant's work lgt(s) extin with switch ON. 2. Relamp extinguished light (AMM 33-22-00).
33 22 26 -- thru 33 22 28 --	Not Used
33 22 29 00	1. (Report location by nearest seat no.) closet lights will not illuminate. 2. Relamp extinguished light (AMM 33-22-00). If fault persists, replace closet light switch (WDM 33-22-21).
33 24 01 00	1. No smoking switch fails to sound chime. (Ref Chapter 23 for fault code diagram.) 2. FIM 33-24-00/101, Fig. 104, Block 1
33 24 02 00	1. Fasten seat belt switch fails to sound chime. (Ref Chapter 23 for fault code diagram.) 2. FIM 33-24-00/101, Fig. 105, Block 1
33 24 03 00	1. When switch ON, no smoking lgts illum. Chime failed to sound. 2. Replace passenger address amplifier M177 (AMM 23-31-01).

EFFECTIVITY

ALL

33-FAULT CODE INDEX

20

Page 14
May 10/96

BOEING
 767
 FAULT ISOLATION/MAINT MANUAL

FAULT CODE	1. LOG BOOK REPORT 2. FAULT ISOLATION REFERENCE
33 24 04 00	1. When switch ON, all no smoking lgts remained extin. 2. FIM 33-24-00/101, Fig. 104, Block 10
33 24 05 00	1. When switch ON, no smoking lgt at (report nearest seat no.) failed to illum. 2. Relamp extinguished light (AMM 33-24-00).
33 24 06 00	1. With switch in AUTO, and landing gear retracted, all no smoking lgts fail to extin. 2. FIM 33-24-00/101, Fig. 104, Block 11
33 24 07 00	1. With switch in AUTO, and ldg. gear extended, all no smoking lgts fail to illum. 2. FIM 33-24-00/101, Fig. 104, Block 14
33 24 10 --	1. SAS 767-300 AIRPLANES; Return to seat lgt in (01=F-1, 02=MS-LF, 03=MC-F, 04=MS-RF, 05=MS-LA, 06=MC-A, 07=MS-RA) lav is (extin, partially illum) with switch ON. 2. Relamp extinguished light (AMM 33-24-00).
33 24 10 00	1. RETURN TO SEAT light in (specify lav location) lavatory is (extinguished, partially illuminated) with switch ON. 2. Relamp extinguished light (AMM 33-24-00).
33 24 11 --	Not Used
33 24 17 -- thru 33 24 21 --	Not Used
33 24 22 00	1. With no smoking sw in AUTO and landing gear retracted, no smoking signs and chime cycled on and off. 2. Replace Cabin Pressure Switch S467 (WDM 33-24-11). If fault persists, perform PSEU BITE procedure (FIM 32-09-03/101, Fig. 103, Block 1).

EFFECTIVITY

ALL

33-FAULT CODE INDEX

20

Page 15
Apr 22/01

BOEING
 767
 FAULT ISOLATION/MAINT MANUAL

FAULT CODE	1. LOG BOOK REPORT 2. FAULT ISOLATION REFERENCE
33 24 23 00	1. With seatbelts sw in AUTO and landing gear retracted, seatbelt signs and chimes cycle on and off. 2. Replace Cabin Pressure Switch S467 (WDM 33-24-11). If fault persists, perform PSEU BITE procedure (FIM 32-09-03/101, Fig. 103, Block 1).
33 24 24 00	1. Cabin chime sounds intermittently with (fasten seatbelt/no smoking) sw in AUTO. (Ref Chapter 23 for fault code diagram.) 2. Replace Cabin Pressure Switch S467 (WDM 33-24-11). If fault persists, replace Flap/Slat Electronic Unit M545 (AMM 27-51-01). If fault persists, replace Proximity Switch Elex Unit M162 (AMM 32-09-04).
33 24 25 -- thru 33 24 27 --	Not Used
33 25 01 --	1. (01=A, 02=B, 03=C, 04=D, 05=E, 06=F) lav call lgt reset sw will not reset call lght(s). (Ref Chapter 23 for fault code diagram). 2. Replace attendant call/reset switch (S3) (WDM 33-25-11).
33 25 02 --	1. (08=Fwd L, 09=Fwd R, 12=Mid ctr L, 13=Mid ctr R, 14=Mid aft L, 15=Mid aft R, 16=Aft L, 17=Aft R, 18=All) amber lav call lgt inop. (Ref Chapter 23 for fault code diagram). 2. FIM 33-25-00/101, Fig. 103, Block 1
33 25 03 --	1. (08=Fwd L, 10=Mid L, 11=Mid R, 16=Aft L, 17=Aft R) lav call chime inop when calling from _____ lav. Lav call lgts are normal. (Ref Chapter 23 for fault code diagram). 2. FIM 33-25-00/101, Fig. 103, Block 1
33 25 04 --	Not Used
33 25 05 --	1. (01=A, 02=B, 03=C, 04=D, 05=E, 06=F, 18=All) lav call sw(s) will not illum call lgts or sound chime. (Ref Chapter 23 for fault code diagram). 2. FIM 33-25-00/101, Fig. 103, Block 1

EFFECTIVITY

ALL

33-FAULT CODE INDEX

BOEING
 767
 FAULT ISOLATION/MAINT MANUAL

FAULT CODE	1. LOG BOOK REPORT 2. FAULT ISOLATION REFERENCE
33 25 06 --	1. (01=A, 02=B, 03=C, 04=D, 05=E, 06=F) lav call lgt reset sw lgt by lav door inop. (Ref Chapter 23 for fault code diagram). 2. FIM 33-25-00/101, Fig. 103, Block 1
33 25 07 --	1. (08=Fwd L, 10=Mid L, 11=Mid R, 16=Aft L, 17=Aft R) chime sounds intermittently. (Ref Chapter 23 for fault code diagram). 2. FIM 33-25-00/101, Fig. 103A, Block 1
33 25 08 --	1. (01=F-1, 02=MC-F, 03=MS-LF, 04=MS-RF, 05=MC-A, 06=MS-LA, 07=MS-RA) lav call lgt reset sw will not reset call lght(s). (Ref Chapter 23 for fault code diagram). 2. Replace attendant call/reset switch (S3) (WDM 33-25-11).
33 25 09 --	1. (01=F-1, 02=MC-F, 03=MS-LF, 04=MS-RF, 05=MC-A, 06=MS-LA, 07=MS-RA) lav call lgt reset sw lgt by lav door inop. (Ref Chapter 23 for fault code diagram). 2. FIM 33-25-00/101, Fig. 103, Block 1
33 25 10 --	1. (08=Fwd L, 09=Fwd R, 10=Mid fwd L, 11=Mid fwd R, 12=Mid L, 13=Mid R, 14=Mid ctr L, 15=Mid ctr R, 16=Mid aft L, 17=Mid aft R, 18=Aft L, 19=Aft R) amber lav call lgt inop. (Ref Chapter 23 for fault code diagram). 2. FIM 33-25-00/101, Fig. 103, Block 1
33 25 11 --	1. (08=Fwd L, 09=Fwd R, 12=Mid L, 13=Mid R, 18=Aft L, 19=Aft R, 20=Purser) lav call chime inop when calling from _____ lav. Lav call lgts are normal. (Ref Chapter 23 for fault code diagram). 2. FIM 33-25-00/101, Fig. 103, Block 1

EFFECTIVITY

ALL

33-FAULT CODE INDEX

BOEING
 767
 FAULT ISOLATION/MAINT MANUAL

FAULT CODE	1. LOG BOOK REPORT 2. FAULT ISOLATION REFERENCE
33 25 12 --	1. (01=F-1, 02=MC-F, 03=MS-LF, 04=MS-RF, 05=MC-A, 06=MS-LA, 07=MS-RA) lav call sw(s) will not illum call lgts or sound chime. (Ref Chapter 23 for fault code diagram). 2. FIM 33-25-00/101, Fig. 103, Block 1
33 25 13 --	1. (08=Fwd L, 09=Fwd R, 12=Mid L, 13=Mid R, 18=Aft L, 19=Aft R, 20=Purser) chime sounds intermittently. (Ref Chapter 23 for fault code diagram). 2. FIM 33-25-00/101, Fig. 103A, Block 1
33 26 01 00	1. LAVATORY sign lgt (specify location or seat no.) (failed to illum, dim, etc). 2. Relamp extinguished light (AMM 33-26-00).
33 26 02 00	1. OCCUPIED sign lgt (specify location or seat no.) (failed to illum, dim, etc). 2. Relamp extinguished light (AMM 33-26-00).
33 26 03 --	1. SAS AIRPLANES; (01=F-1, 02=MS-LF, 03=MC-F, 04=MS-RF, 05=MS-LA, 06=MC-A, 07=MS-RA) lav mirror lgts extin. 2. FIM 33-26-00/101, Fig. 103, Block 4
33 26 04 00	1. All lavatory mirror lights extinguished on ground with engines not running. 2. FIM 33-26-00/101, Fig. 103, Block 1
33 26 05 --	1. SAS AIRPLANES; (01=F-1, 02=MS-LF, 03=MC-F, 04=MS-RF, 05=MS-LA, 06=MC-A, 07=MS-RA) lavatory mirror and OCCUPIED lgts do not illum with door latched. 2. FIM 33-26-00/101, Fig. 103, Block 1

EFFECTIVITY

ALL

33-FAULT CODE INDEX

BOEING
 767
 FAULT ISOLATION/MAINT MANUAL

FAULT CODE	1. LOG BOOK REPORT 2. FAULT ISOLATION REFERENCE
33 26 06 --	1. SAS AIRPLANES; (01=F-1, 02=MS-LF, 03=MC-F, 04=MS-RF, 05=MS-LA, 06=MC-A, 07=MS-RA) lavatory mirror lgt(s) (extin, flickers) with door switch latched. 2. FIM 33-26-00/101, Fig. 103, Block 2
33 26 07 --	1. SAS AIRPLANES; (01=F-1, 02=MS-LF, 03=MC-F, 04=MS-RF, 05=MS-LA, 06=MC-A, 07=MS-RA) lav dome lgt inop. 2. Relamp extinguished light (AMM 33-26-00).
33 26 08 00	1. LAVATORY sign light (specify location or seat no.) (failed to illuminate, dimmer, etc). 2. Relamp extinguished light (AMM 33-26-00).
33 26 09 00	1. OCCUPIED sign light (specify location or seat no.) (failed to illuminate, dimmer, etc). 2. Relamp extinguished light (AMM 33-26-00).
33 26 10 --	1. (01=A, 02=B, 03=C, 04=D, 05=E, 06=F,)lavatory dome light inoperative. 2. Relamp extinguished light (AMM 33-26-00).
33 26 11 --	1. (01=A, 02=B, 03=C, 04=D, 05=E, 06=F) lavatory mirror lgt(s) (extin, flickers) with door switch latched. 2. FIM 33-26-00/101, Fig. 103, Block 2
33 26 12 --	1. (01=A, 02=B, 03=C, 04=D, 05=E, 06=F) lav mirror lgts extin. 2. FIM 33-26-00/101, Fig. 103, Block 4

EFFECTIVITY

ALL

33-FAULT CODE INDEX

BOEING
 767
 FAULT ISOLATION/MAINT MANUAL

FAULT CODE	1. LOG BOOK REPORT 2. FAULT ISOLATION REFERENCE
33 26 13 00	1. All lavatory mirror lights extinguished on ground with engines not running. 2. FIM 33-26-00/101, Fig. 103, Block 1
33 26 14 --	1. (01=A, 02=B, 03=C, 04=D, 05=E, 06=F) lavatory mirror and OCCUPIED lgts do not illum with door latched. 2. FIM 33-26-00/101, Fig. 103, Block 1
33 27 01 00	1. All galley lgts extin with all galley lgt switches BRT. 2. FIM 33-27-00/101, Fig. 103, Block 1
33 27 02 00	1. Single light in fwd galley extin or flickers with galley lgt switch BRT. 2. FIM 33-27-00/101, Fig. 103, Block 1
33 27 03 00	1. Both fwd galley lgts extin with galley lgt switch BRT. 2. Relamp extinguished light (AMM 33-27-00).
33 27 04 --	Not Used
33 27 05 --	Not Used
33 27 06 00	1. One AFT galley lgt extin or flickers with galley lgt switch BRT. 2. FIM 33-27-00/101, Fig. 103, Block 26
33 27 07 00	1. Two AFT galley lgts extin with galley lgt switch BRT. 2. FIM 33-27-00/101, Fig. 103, Block 13
33 27 08 00	1. Four AFT galley lgts extin with galley lgt switch BRT. 2. FIM 33-27-00/101, Fig. 103, Block 13

EFFECTIVITY

ALL

33-FAULT CODE INDEX

BOEING
 767
 FAULT ISOLATION/MAINT MANUAL

FAULT CODE	1. LOG BOOK REPORT 2. FAULT ISOLATION REFERENCE
33 27 09 00	1. (Six, seven, eight) Aft galley lights extinguished with galley light switch BRT. 2. FIM 33-27-00/101, Fig. 103, Block 13
33 31 01 --	Not Used
33 31 02 --	Not Used
33 31 03 --	1. (05=Fwd, 06=Aft, 09=All) Nose wheel well light(s) extinguish with switch ON. 2. (05=Fwd, 06=Aft) Relamp extinguished light (AMM 33-31-00). (09=All) Replace nose gear wheel well light switch S324 (WDM 33-31-11).
33 31 04 --	1. The (01=fwd, 02=aft, 03=both) right air conditioning compartment light(s) is (are) extinguished with switch S362 ON. 2. (01=Fwd, 02=Aft) Relamp extinguished light (AMM 33-31-00). (03=Both) Replace right air conditioning compartment lights switch S362 (WDM 33-31-21).
33 31 05 --	1. The (01=fwd, 02=aft, 03=both) left air conditioning compartment light(s) is (are) extinguished with switch S361 ON. 2. (01=Fwd, 02=Aft) Relamp extinguished light (AMM 33-31-00). (03=Both) Replace left air conditioning compartment lights switch S361 (WDM 33-31-21).
33 31 06 --	1. The (01=L, 02=R, 03=both) APU compartment light(s) is (are) extinguished with switch S428 ON. 2. (01=L, 02=R) Relamp extinguished light (AMM 33-31-00). (03=Both) Replace APU compartment light switch S428 (WDM 33-31-33).

EFFECTIVITY

ALL

33-FAULT CODE INDEX

BOEING
 767
 FAULT ISOLATION/MAINT MANUAL

FAULT CODE	1. LOG BOOK REPORT 2. FAULT ISOLATION REFERENCE
33 31 07 00	1. The aft tailcone compartment light is extinguished with switch S443 ON. 2. Relamp aft tailcone compartment light L179 (AMM 33-31-00). If fault persists, perform FIM 33-31-00/101, Fig. 108, Block 1.
33 31 08 00	1. The fwd tailcone compartment light is extinguished with switch S427 ON. 2. Relamp fwd tailcone compartment light L178 (AMM 33-31-00). If fault persists, perform FIM 33-31-00/101, Fig. 108, Block 1.
33 31 09 03	1. At least one but not all main E/E ctr lights are extinguished with switch S356 placed in opposite position. 2. Relamp extinguished light(s) (AMM 33-31-00).
33 31 09 04	1. All main E/E ctr lights are extinguished with switch S356 placed in opposite position. 2. FIM 33-31-00/101, Fig. 110, Block 1
33 31 09 05	1. Main E/E ctr lights L75 and L78 are extinguished with switch S356 placed in opposite position. All other main E/E ctr lights are on. 2. Replace Sys No. 2 Air/Gnd Relay K209 (WDM 33-31-41).
33 31 10 03	1. At least one but not all main E/E ctr lights are extinguished with switch S355 placed in opposite position. 2. Relamp extinguished light(s) (AMM 33-31-00).
33 31 10 04	1. All main E/E ctr lights are extinguished with switch S355 placed in opposite position. 2. FIM 33-31-00/101, Fig. 110, Block 1

EFFECTIVITY

ALL

33-FAULT CODE INDEX

BOEING
 767
 FAULT ISOLATION/MAINT MANUAL

FAULT CODE	1. LOG BOOK REPORT 2. FAULT ISOLATION REFERENCE
33 31 10 05	1. Main E/E ctr lights L75 and L78 are extinguished with switch S355 placed in opposite position. All other main E/E ctr lights are on. 2. Replace Sys No. 2 Air/Gnd Relay K209 (WDM 33-31-41).
33 31 11 03	1. At least one but not all main E/E ctr lights are extinguished with switch S354 placed in opposite position. 2. Relamp extinguished light(s) (AMM 33-31-00).
33 31 11 04	1. All main E/E ctr lights are extinguished with switch S354 placed in opposite position. 2. FIM 33-31-00/101, Fig. 110, Block 1
33 31 11 05	1. Main E/E ctr lights L75 and L78 are extinguished with switch S354 placed in opposite position. All other main E/E ctr lights are on. 2. Replace Sys No. 2 Air/Gnd Relay K209 (WDM 33-31-41).
33 31 12 --	1. The (01=fwd, 02=aft, 04=all) fwd E/E ctr light(s) is (are) extinguished with switch S357 ON. 2. (01=Fwd, 02=Aft) Relamp extinguished light(s) (AMM 33-31-00). (04=ALL) FIM 33-31-00/101, Fig. 109, Block 1
33 31 13 --	1. The (01=fwd, 02=aft, 05=all) bulk cargo exterior light(s) is (are) extinguished with switch S379 ON. 2. (01=Fwd, 02=Aft) Relamp extinguished light (AMM 33-31-00). (05=ALL) FIM 33-31-00/101, Fig. 113, Block 1
33 31 14 --	1. The (01=fwd, 02=aft) aft cargo door light is extinguished with switch S516 ON. The aft cargo exterior light is on. 2. Relamp extinguished light (AMM 33-31-00).

EFFECTIVITY

ALL

33-FAULT CODE INDEX

BOEING
 767
 FAULT ISOLATION/MAINT MANUAL

FAULT CODE	1. LOG BOOK REPORT 2. FAULT ISOLATION REFERENCE
33 31 14 03	1. The aft cargo exterior light is extinguished with switch S516 ON. The aft cargo door lights are on. 2. Relamp aft cargo exterior light L138 (AMM 33-31-00).
33 31 14 04	1. The aft cargo door lights are extinguished with switch S516 ON. The aft cargo exterior light is on. 2. Replace aft cargo door lights enable relay K422 (WDM 33-31-61).
33 31 14 05	1. All aft cargo exterior and door lights are extinguished with switch S516 ON. 2. FIM 33-31-00/101, Fig. 112, Block 1
33 31 15 --	1. The (01=fwd, 02=aft) fwd cargo door light is extinguished with switch S515 ON. The fwd cargo exterior light is on. 2. Relamp extinguished light (AMM 33-31-00).
33 31 15 03	1. The fwd cargo exterior light is extinguished with switch S515 ON. The fwd cargo door lights are on. 2. Relamp fwd cargo exterior light L137 (AMM 33-31-00).
33 31 15 04	1. The fwd cargo door lights are extinguished with switch S515 ON. The fwd cargo exterior light is on. 2. Replace fwd cargo door lights enable relay K30 (WDM 33-31-61).
33 31 15 05	1. All fwd cargo exterior and door lights are extinguished with switch S515 ON. 2. FIM 33-31-00/101, Fig. 111, Block 1
33 31 16 --	1. (01=L fwd, 02=L aft, 03=R fwd, 04=R aft) Wheel well light extinguished. 2. Relamp extinguished light (AMM 33-31-00).

EFFECTIVITY

ALL

33-FAULT CODE INDEX

BOEING
 767
 FAULT ISOLATION/MAINT MANUAL

FAULT CODE	1. LOG BOOK REPORT 2. FAULT ISOLATION REFERENCE
33 31 17 --	1. All wheel well lights extinguish with (07=L, 08=R) wheel light switch ON. All lights illuminate with opposite switch on. 2. Replace L (R) wheel well light switch S468 (S319) (WDM 33-31-11).
33 31 18 00	1. All wheel well lights extinguish with both wheel well light switches ON. 2. FIM 33-31-00/101, Fig. 104, Block 1
33 37 01 01	1. At least one but not all fwd cargo compartment overhead lights are extinguished with fwd cargo compartment access door open. 2. Relamp extinguished light(s) (AMM 33-37-00).
33 37 01 02	1. All fwd cargo compartment overhead lights are extinguished with fwd cargo compartment access door open. 2. FIM 33-37-00/101, Fig. 103, Block 1
33 37 02 01	1. At least one but not all fwd cargo compartment overhead lights are extinguished with switch S402 placed in opposite position. 2. Relamp extinguished light(s) (AMM 33-37-00).
33 37 02 02	1. All fwd cargo compartment overhead and door lights are extinguished with switch S402 placed in opposite position. 2. FIM 33-37-00/101, Fig. 104, Block 1
33 37 02 03	1. Both fwd cargo compartment door lights are extinguished with switch S402 placed in opposite position. The fwd cargo compartment overhead lights are on. 2. Replace fwd cargo door lights enable relay K30 (WDM 33-37-11).

EFFECTIVITY

ALL

33-FAULT CODE INDEX

BOEING
 767
 FAULT ISOLATION/MAINT MANUAL

FAULT CODE	1. LOG BOOK REPORT 2. FAULT ISOLATION REFERENCE
33 37 02 --	1. The (04=fwd, 05=aft) fwd cargo compartment door light is extinguished with switch S402 placed in opposite position. The fwd cargo compartment overhead lights are on. 2. Relamp extinguished light (AMM 33-37-00).
33 37 03 01	1. At least one but not all fwd cargo compartment overhead lights are extinguished with switch S513 placed in opposite position. 2. Relamp extinguished light(s) (AMM 33-37-00).
33 37 03 02	1. All fwd cargo compartment overhead and door lights are extinguished with switch S513 placed in opposite position. 2. FIM 33-37-00/101, Fig. 104, Block 1
33 37 03 03	1. Both fwd cargo compartment door lights are extinguished with switch S513 placed in opposite position. The fwd cargo compartment overhead lights are on. 2. Replace fwd cargo door lights enable relay K30 (WDM 33-37-11).
33 37 03 --	1. The (04=fwd, 05=aft) fwd cargo compartment door light is extinguished with switch S513 placed in opposite position. The fwd cargo compartment overhead lights are on. 2. Relamp extinguished light (AMM 33-37-00).
33 37 04 01	1. At least one but not all aft cargo compartment overhead lights are extinguished with switch S430 placed in opposite position. 2. Relamp extinguished light(s) (AMM 33-37-00).
33 37 04 02	1. All aft cargo compartment overhead and door lights are extinguished with switch S430 placed in opposite position. 2. FIM 33-37-00/101, Fig. 105, Block 1

EFFECTIVITY

ALL

33-FAULT CODE INDEX

BOEING
 767
 FAULT ISOLATION/MAINT MANUAL

FAULT CODE	1. LOG BOOK REPORT 2. FAULT ISOLATION REFERENCE
33 37 04 03	1. The aft cargo compartment door light is extinguished with switch S430 placed in opposite position. The aft cargo compartment overhead lights are on. 2. Relamp aft cargo compartment doorsill light L546 (AMM 33-37-00). If fault persists, replace aft cargo door lights enable relay K422 (WDM 33-37-21).
33 37 05 01	1. At least one but not all aft cargo compartment overhead lights are extinguished with switch S429 placed in opposite position. 2. Relamp extinguished light(s) (AMM 33-37-00).
33 37 05 02	1. All aft cargo compartment overhead and door lights are extinguished with switch S429 placed in opposite position. 2. FIM 33-37-00/101, Fig. 105, Block 1
33 37 05 03	1. The aft cargo compartment door light is extinguished with switch S429 placed in opposite position. The aft cargo compartment overhead lights are on. 2. Relamp aft cargo compartment doorsill light L546 (AMM 33-37-00). If fault persists, replace aft cargo door lights enable relay K422 (WDM 33-37-21).
33 37 06 01	1. At least one but not all aft cargo compartment overhead lights are extinguished with switch S514 placed in opposite position. 2. Relamp extinguished light(s) (AMM 33-37-00).
33 37 06 02	1. All aft cargo compartment overhead and door lights are extinguished with switch S514 placed in opposite position. 2. FIM 33-37-00/101, Fig. 105, Block 1

EFFECTIVITY

ALL

33-FAULT CODE INDEX

BOEING
 767
 FAULT ISOLATION/MAINT MANUAL

FAULT CODE	1. LOG BOOK REPORT 2. FAULT ISOLATION REFERENCE
33 37 06 03	1. The aft cargo compartment door light is extinguished with switch S514 placed in opposite position. The aft cargo compartment overhead lights are on. 2. Relamp aft cargo compartment doorsill light L546 (AMM 33-37-00). If fault persists, replace aft cargo door lights enable relay K422 (WDM 33-37-21).
33 41 01 --	1. (01=L, 02=R, 03=Both) wing light(s) failed to illuminate with switch ON. 2. (01=L, 02=R) Relamp L(R) wing illumination light L61 (L60) (AMM 33-41-00). (03=Both) Replace anti-collision and landing light control module M56 (FIM 33-44-00/101, Fig. 101).
33 42 01 --	1. (01=L, 02=R, 03=Both) Taxi light(s) failed to illuminate with switch ON. 2. FIM 33-42-00/101, Fig. 104, Block 1
33 42 02 --	1. (01=L, 02=R) Runway turnoff light failed to illuminate with switch ON. 2. FIM 33-42-00/101, Fig. 105, Block 1
33 42 02 03	1. Both runway turnoff lights failed to illuminate with switch ON. 2. Replace left lighting control module M10056 (WDM 33-42-21).
33 42 03 --	1. (01=L, 02=R) Nose gear landing light failed to illuminate with switch ON. 2. FIM 33-42-00/101, Fig. 106, Block 1

EFFECTIVITY

ALL

33-FAULT CODE INDEX

BOEING
 767
 FAULT ISOLATION/MAINT MANUAL

FAULT CODE	1. LOG BOOK REPORT 2. FAULT ISOLATION REFERENCE
33 42 03 03	1. Both nose gear landing lights failed to illuminate with switch ON. 2. FIM 33-42-00/101, Fig. 106, Block 3
33 42 04 00	1. Wing landing lights remained bright with landing gear retracted. 2. Replace landing gear lever module M937 (landing gear lever switch [S3] is faulty) (AMM 32-31-01).
33 42 05 --	1. (01=L, 02=R, 03=Both) Wing landing light(s) failed to illuminate with switch ON. 2. FIM 33-42-00/101, Fig. 106, Block 1
33 43 01 --	1. One(01=L white, 02=L red, 03=R white, 04=R green) position light failed to illuminate. 2. Relamp position light L107 (left red) or L108 (right green) (AMM 33-43-01); or L105 (left white) or L106 (right white) (AMM 33-43-02).
33 43 02 --	1. Both (01=L white, 02=L red, 03=R white, 04=R green) position lights failed to illuminate. 2. Relamp position lights L107 (left red) or L108 (right green) (AMM 33-43-01); or L105 (left white) or L106 (right white) (AMM 33-43-02).
33 43 03 --	1. One (02=L red, 04=R green) and one white position light failed to illuminate. 2. Replace position light transformer A T131 (left) or T132 (right) or position light transformer B T133 (left) or T134 (right) (AMM 33-43-03).

EFFECTIVITY

ALL

33-FAULT CODE INDEX

09

Page 29
Dec 22/01

BOEING
 767
 FAULT ISOLATION/MAINT MANUAL

FAULT CODE	1. LOG BOOK REPORT 2. FAULT ISOLATION REFERENCE
33 44 01 --	1. (01=L white, 03=R white, 05=upper fuselage, 06=lower fuselage) Anti-collision light(s) failed to illuminate. 2. Replace the lamp in the anti-collision light assembly. If the fault continues, replace the anti-collision light assembly. If fault continues, replace power supply. Left wing tip L101 (AMM 33-44-01) or M588 (AMM 33-44-03). Right wing tip L102 (AMM 33-44-01) or M589 (AMM 33-44-03). Upper fuselage L103 (AMM 33-44-02) or M570 (AMM 33-44-04). Lower fuselage L104 (AMM 33-44-02) or M571 (AMM 33-44-04).
33 45 01 --	1. (01=L inbd, 02=L outbd, 03=R inbd, 04=R outbd) logo lgt extin with switch on. 2. FIM 33-45-00/101, Fig. 103, Block 1
33 45 02 --	1. (05=LH, 06=RH) logo lgts extin with switch on. 2. FIM 33-45-00/101, Fig. 103, Block 1
33 45 03 00	1. All logo lgts extin with switch on. 2. FIM 33-45-00/101, Fig. 103, Block 1
33 51 01 --	1. (02=Fwd L, 03=Fwd R, 08=Aft L, 09=Aft R) EXIT/THRESHOLD sign is extin with atnd (emerg test sw) ON. 2. Relamp extinguished light (AMM 33-51-00).
33 51 02 --	1. (02=Fwd L, 03=Fwd R, 05=Mid L, 06=Mid R, 08=Aft L, 09=Aft R) EXIT sign is extin with atnd (emerg test sw) ON. (Specify nearest seat, if applicable). 2. Relamp extinguished light (AMM 33-51-00).
33 51 03 --	1. (02=Fwd L, 03=Fwd R, 04=Mid, 05=Mid L, 06=Mid R, 08=Aft L, 09=Aft R) lowered ceiling lights is extinguished with attendant's (emergency test switch) ON. 2. Relamp extinguished light (AMM 33-51-00).
33 51 04 --	1. (02=Fwd L, 03=Fwd R, 08=Aft L, 09=Aft R) door lgt is extin with atnd (emerg test sw) ON. 2. Relamp extinguished light (AMM 33-51-00).
33 51 05 --	1. (02=Fwd L, 03=Fwd R, 05=Mid L, 06=Mid R, 08=Aft L, 09=Aft R) aisle lgt is extin with atnd (emerg test sw) ON. (Specify location by nearest seat no.) 2. Relamp extinguished light (AMM 33-51-00).

EFFECTIVITY

ALL

33-FAULT CODE INDEX

06

Page 30
Apr 22/01

BOEING
 767
 FAULT ISOLATION/MAINT MANUAL

FAULT CODE	1. LOG BOOK REPORT 2. FAULT ISOLATION REFERENCE
33 51 06 00	1. All exterior emergency lights extinguish on same side of airplane as entry/service door or escape hatch under test. 2. FIM 32-09-03/101, Fig. 104, Block 1
33 51 07 --	1. (01=Fwd, 02=Aft, 03=All) right side exterior emergency lights extinguish with test switch to RS. 2. FIM 33-51-00/101, Fig. 104, Block 1
33 51 08 --	1. (01=Fwd, 02=Aft, 03=All) left side exterior emergency lights extinguish with test switch to LS. 2. FIM 33-51-00/101, Fig. 104, Block 2
33 51 09 --	1. (02=Fwd L, 03=Fwd R, 05=Mid L, 06=Mid R, 08=Aft L, 09=Aft R, 10=L Emer, 11=R Emer, 12=Floor emer escape path) cabin area emergency lgts (fail to illum, dim) during test or on. (describe) 2. FIM 33-51-00/101, Fig. 103, Block 1
33 51 10 00	1. Emergency lgts failed to test. 2. FIM 33-51-00/101, Fig. 103, Block 1
33 51 11 00	1. Flight deck emer exit lgt (failed to illum, dim) with ovhd emer lgts sw ON. All cabin emer lgts were normal. 2. Relamp flight deck emergency exit light L286 (AMM 33-51-01).
33 51 12 00	1. Flight deck and main cabin emer lgts failed to illum with ovhd emer lgts sw ON. 2. Replace ovhd emergency lights switch YBIS1 (WDM 33-51-11).
33 51 13 00	1. EICAS msg EMER LIGHTS did not display and UNARMED lgt did not illum with ovhd emer lgts sw ON. All emer lgts illum norm. 2. Replace ovhd emergency lights switch YBIS1 (WDM 33-51-11).
33 51 14 00	1. EICAS msg EMER LIGHTS did not display, UNARMED lgt and all emer lgts failed to illum with ovhd emer lgts sw ON. 2. Replace ovhd emergency lights switch YBIS1 (WDM 33-51-11).
33 51 15 00	1. EICAS msg EMER LIGHTS displayed and UNARMED lgt illum with emer lgts sw ARMED. 2. Replace ovhd emergency lights switch YBIS1 (WDM 33-51-11).
33 51 16 00	1. EICAS msg EMER LIGHTS did not display and UNARMED lgt did not illum with ovhd emer lgts sw OFF. 2. Replace ovhd emergency lights switch YBIS1 (WDM 33-51-11).

EFFECTIVITY

ALL

33-FAULT CODE INDEX

04

Page 31
May 10/96

BOEING
 767
 FAULT ISOLATION/MAINT MANUAL

FAULT CODE	1. LOG BOOK REPORT 2. FAULT ISOLATION REFERENCE
33 51 17 --	1. (02=Fwd L, 03=Fwd R, 08=Aft L, 09=Aft R, 10=L Emer, 11=R Emer) exit identifier light(s) inoperative with attendant's (emergency test switch) ON. 2. FIM 33-51-00/101, Fig. 103, Block 1
33 51 18 00	1. Floor emer escape path lgt(s) (state location) inop with atnd (emer test sw) ON. 2. FIM 33-51-00/101, Fig. 103, Block 1

EFFECTIVITY

ALL

33-FAULT CODE INDEX

BITE Index

1. General

- A. Use this index to find the BITE procedure for the applicable LRU/System.
- B. The BITE procedure will provide the fault isolation instructions for the fault indications/LRU maintenance messages.

<u>LRU/System Name</u>	<u>Acronym</u>	<u>FIM Reference</u>
ACARS Management Unit		23-22
Air Data Computer	ADC	34-12
Air Data Inertial Reference Unit	ADIRU	34-26
Air Supply Control and Test Unit	ASCTU	36-20
Air Traffic Control Transponder	ATC	34-53
Airborne Vibration Monitor Signal Conditioner	AVM	77-31
Antiskid/Autobrake Control Unit	AACU	32-42
APU Fire Detection System		26-15
Automatic Direction Finder Receiver	ADF	34-57
APU Control Unit (or Electronic Control Unit)	ECU	49-11
Autopilot/Flight Director	AFDS	22-00
Auxiliary Zone Temperature Controller	AZTC	2160/21-61
Brake Temperature Monitor Unit	BTMU	32-46
Bus Power Control Unit	BPCU	24-20
Cabin Pressure Controller	CPC	21-30/21-31
Cabin Temperature Controller	CTC	21-61
Digital Flight Data Acquisition Unit	DFDAU	31-31
Distance Measuring Equipment Interrogator	DME	34-55
Duct Leak (Wing and Body)		26-18
E/E Cooling Control Card (If cards installed)		21-58
ECS Bleed Configuration Card		36-10
Electronic Control Unit	ECU	49-11
Electronic Engine Control Monitor Unit (Non-FADEC Engines)	EECM	71-EECM Message Index
Electronic Flight Instrument System	EFIS	34-22

Bite Index
Figure 1 (Sheet 1)

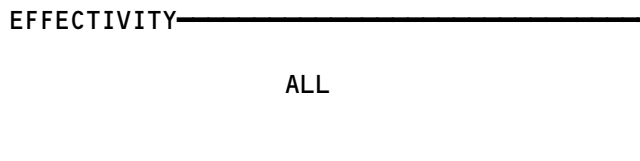

33-BITE INDEX

BOEING
 767
 FAULT ISOLATION/MAINT MANUAL

<u>LRU/System Name</u>	<u>Acronym</u>	<u>FIM Reference</u>
Engine Fire/Overheat Detection System		26-11
Engine Indication and Crew Alerting System Computer	EICAS	31-41
Enhanced Ground Proximity Warning Computer	EGPWC	34-46
Equipment Cooling System Controller		21-58
Equipment Cooling Temperature Controller		21-58
Flap/Slat Electronic Unit	FSEU	27-51
Flap/Stabilizer Position Module	FSPM	27-58
Flight Management Computer	FMC	34-61
Fuel Quantity Indicating System Processor	FQIS	28-41
Ground Proximity Warning Computer	GPWC	34-46
HF (High Frequency) Communication		23-11
In-Flight Entertainment Equipment Cooling Card		21-58
Inertial Reference Unit	IRU	34-21
Instrument Comparator Unit	ICU	34-25
Instrument Landing System Receiver	ILS	34-31
Large Format Display System	LFDS	31-63
Lower Cargo Compartment Smoke Detection System		26-16
Maintenance Control Display Panel	MCDP	22-00
Multi-Mode Receiver	MMR	34-31
PA (Passenger Address) Amplifier		23-31
Pack Standby Temperature Controller	PSTC	21-51
Pack Temperature Controller	PTC	21-51
Passenger Entertainment System	PES	23-34
Power Supply Module (Control System Electronics Units)	PSM	27-09
Propulsion Interface and Monitor Unit (FADEC Engines)	PIMU	71-PIMU Message Index
Proximity Switch Electronics Unit	PSEU	32-09

Bite Index
Figure 1 (Sheet 2)

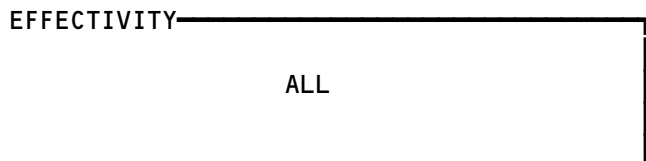

33-BITE INDEX



767

FAULT ISOLATION/MAINT MANUAL

<u>LRU/System Name</u>	<u>Acronym</u>	<u>FIM Reference</u>
Radio Altimeter Transmitter/Receiver	RA	34-33
Rudder Ratio Changer Module	RRCM	27-09
Satellite Data Unit	SDU	23-25
Spoiler Control Module	SCM	27-09
Stabilizer Trim/Elevator Asymmetry Limit Module	SAM	27-09
Stall Warning Computer/Module (in Warning Electronic Unit)	SWC	27-32
Strut Overheat Detection System (RR Engines)		26-12
Thrust Management Computer/Autothrottle	TMC	22-00
Traffic Alert and Collision Avoidance Computer	TCAS	34-45
VHF (Very High Frequency) Communication		23-12
VOR/Marker Beacon Receiver	VOR/MKR	34-51
Warning Electronic Unit BITE Module (Stall Warning)	WEU	27-32
Weather Radar Transceiver	WXR	34-43
Wheel Well Fire Detection		26-17
Window Heat Control Unit	WHCU	30-41
Yaw Damper Module	YDM	22-21
Yaw Damper/Stabilizer Trim Module	YSM	27-09
Zone Temperature Controller	ZTC	21-60/21-61

Bite Index
Figure 1 (Sheet 3)

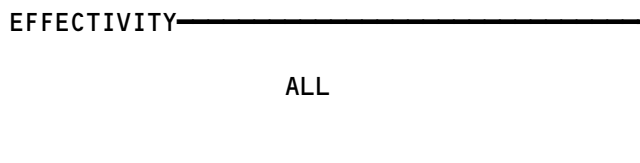

33-BITE INDEX

01

Page 3
Aug 22/99



767

FAULT ISOLATION/MAINT MANUAL

FLIGHT COMPARTMENT ILLUMINATION

COMPONENT*	FIG. 102 SHT	QTY *	ACCESS/AREA	AMM REFERENCE
CIRCUIT BREAKER -	1		FLT COMPT, P11	*
CIRCUIT BREAKER -	2		119AL, MAIN EQUIP CTR, P33	*
DIMMER CONTROL UNIT, FLOODLIGHT	2		FLT COMPT, P9	33-11-03
LIGHT -				
FLOOD				33-11-00
DOME				33-11-00
SWITCH -				
LIGHT	1		FLT COMPT, P5, P7 AND P61	*

* SEE THE SSM OR WDM FOR THE EQUIPMENT NUMBER, QUANTITY AND LOCATION OF EACH COMPONENT IN THE LIGHTING CIRCUIT.

Flight Compartment Illumination - Component Index
Figure 101

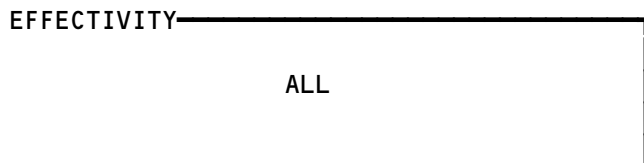

33-11-00

01

Page 101
Feb 10/94

123748

BOEING
767
FAULT ISOLATION/MAINT MANUAL

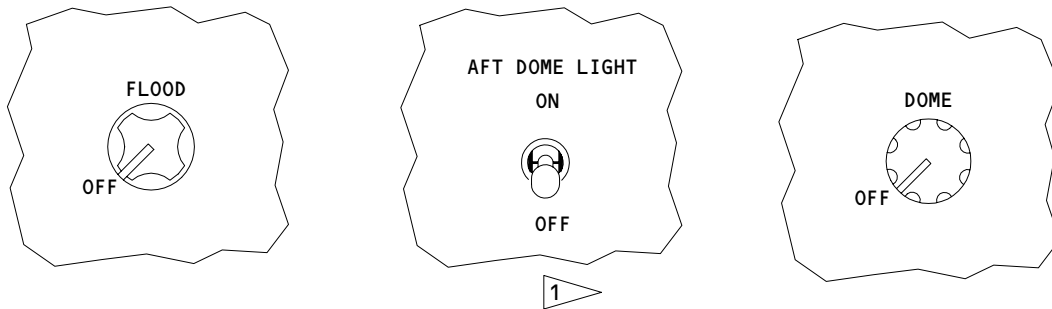
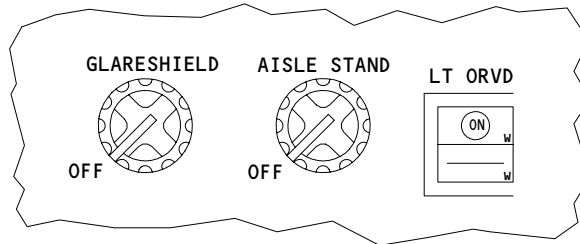
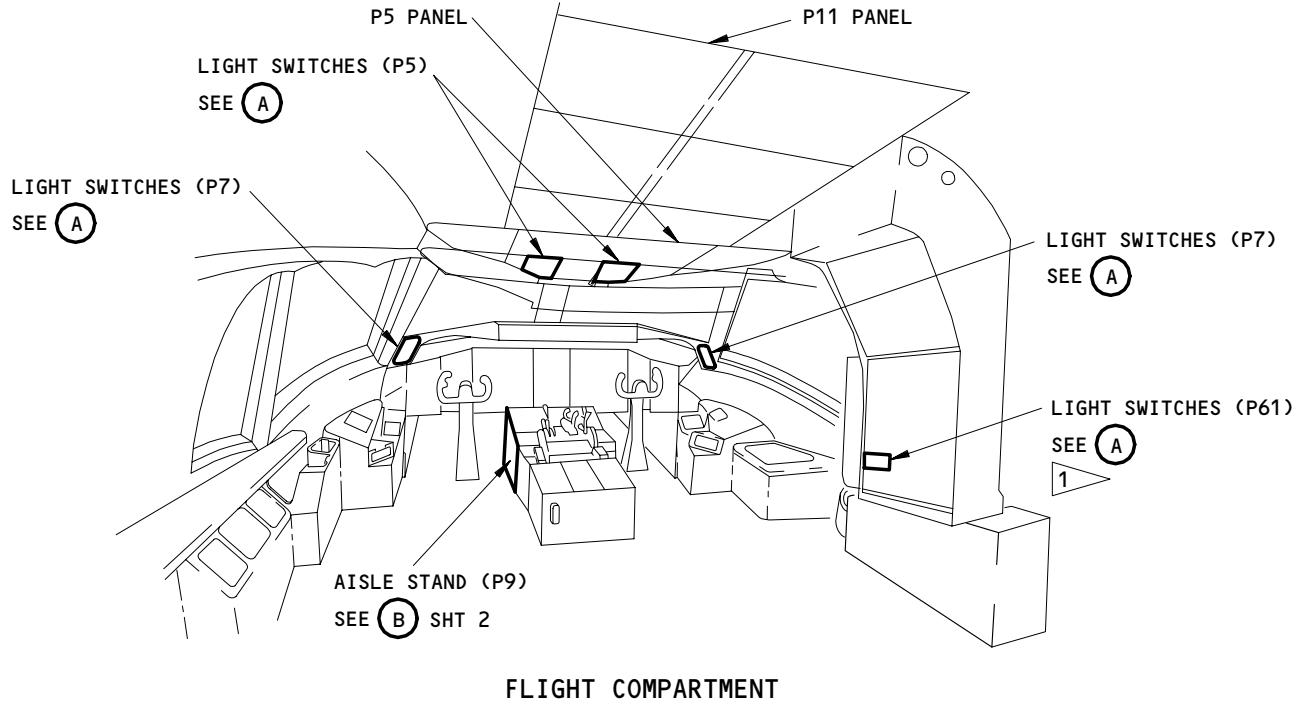

**LIGHT SWITCHES
(EXAMPLE)**

(A)

1 NOT INSTALLED ON ALL AIRPLANES

**Flight Compartment Illumination - Component Location
Figure 102 (Sheet 1)**

EFFECTIVITY	ALL
-------------	-----

33-11-00

01

Page 102
Feb 10/94

223853

BOEING
767
FAULT ISOLATION/MAINT MANUAL

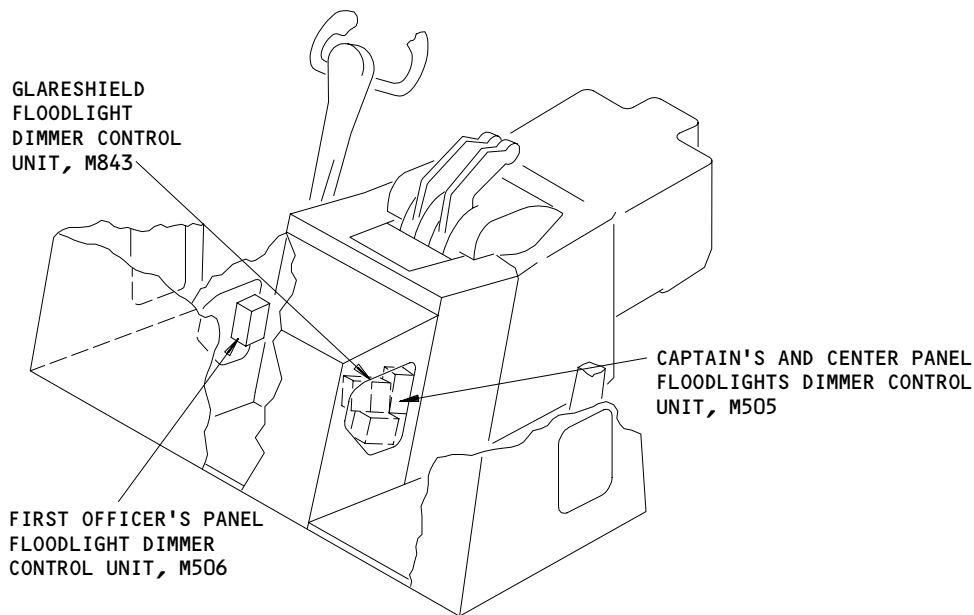

AISLE STAND (P9)

B

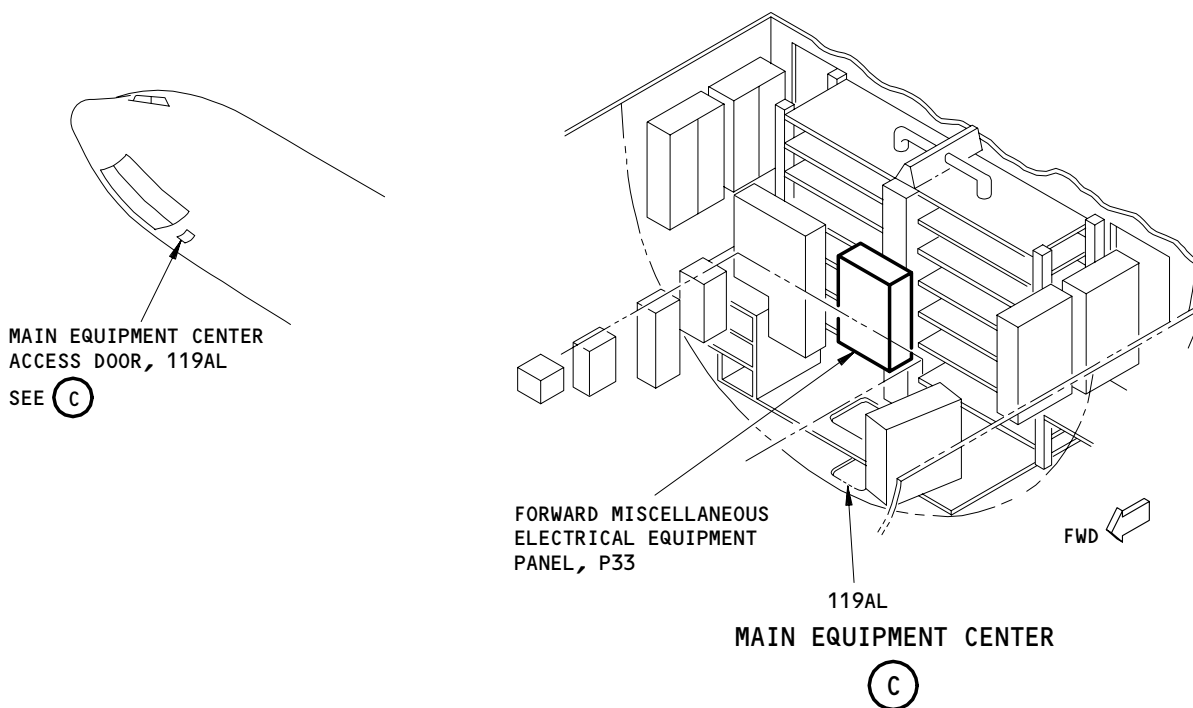

Flight Compartment Illumination - Component Location
Figure 102 (Sheet 2)

EFFECTIVITY	ALL
-------------	-----

33-11-00

01

Page 103
Feb 10/94

D18201

**FLIGHT COMPARTMENT
PANEL FLOODLIGHT
PROBLEMS**

PREREQUISITES
MAKE SURE THESE CIRCUIT BREAKERS ARE CLOSED:
11B4,11P5,33K7
MAKE SURE THE AIRPLANE IS IN THE CONFIGURATION THAT
FOLLOWS:
ELECTRICAL POWER IS ON (MM 24-22-00/201)

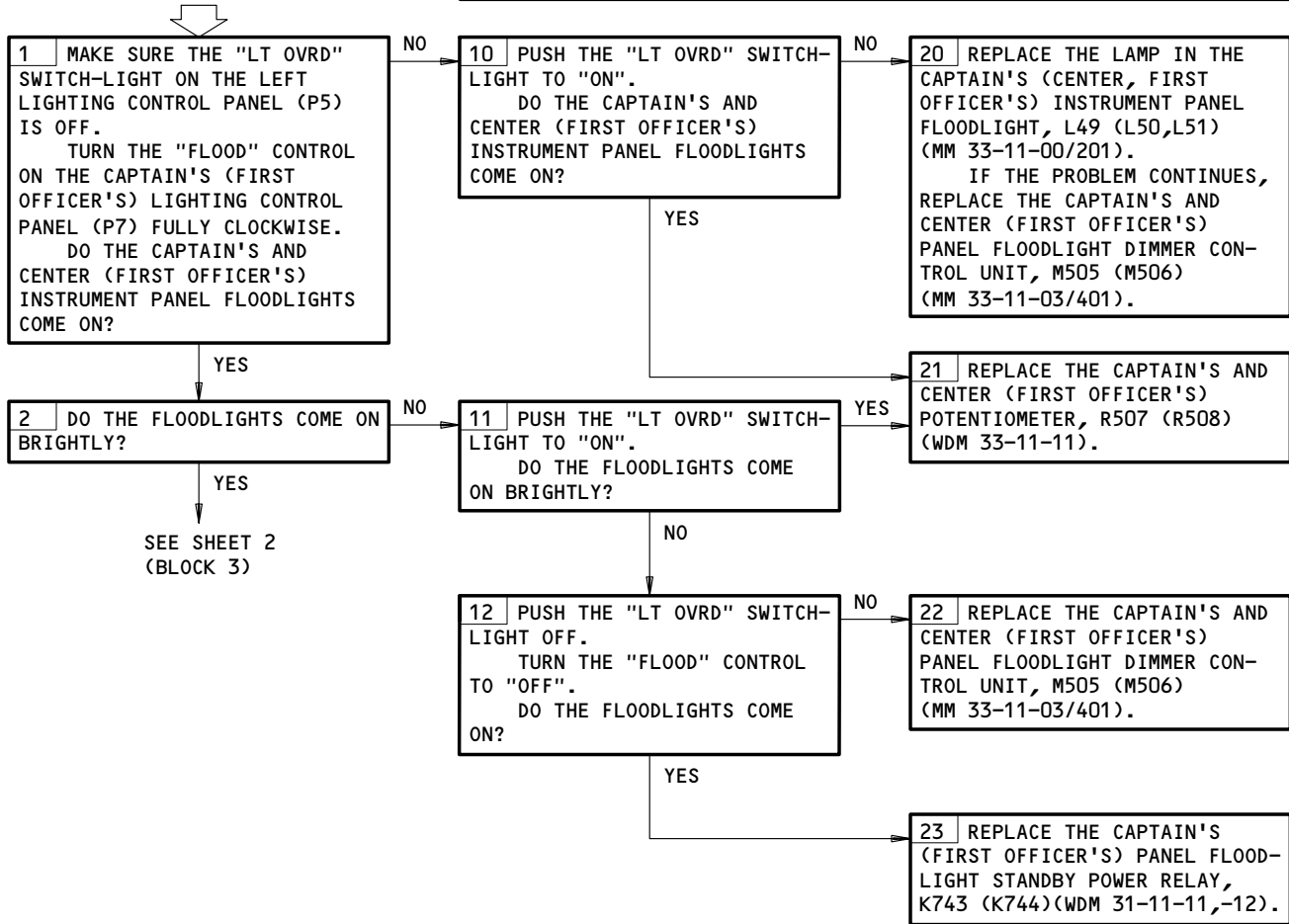

Flight Compartment Panel Floodlight Problems
Figure 103 (Sheet 1)

EFFECTIVITY	ALL
-------------	-----

33-11-00

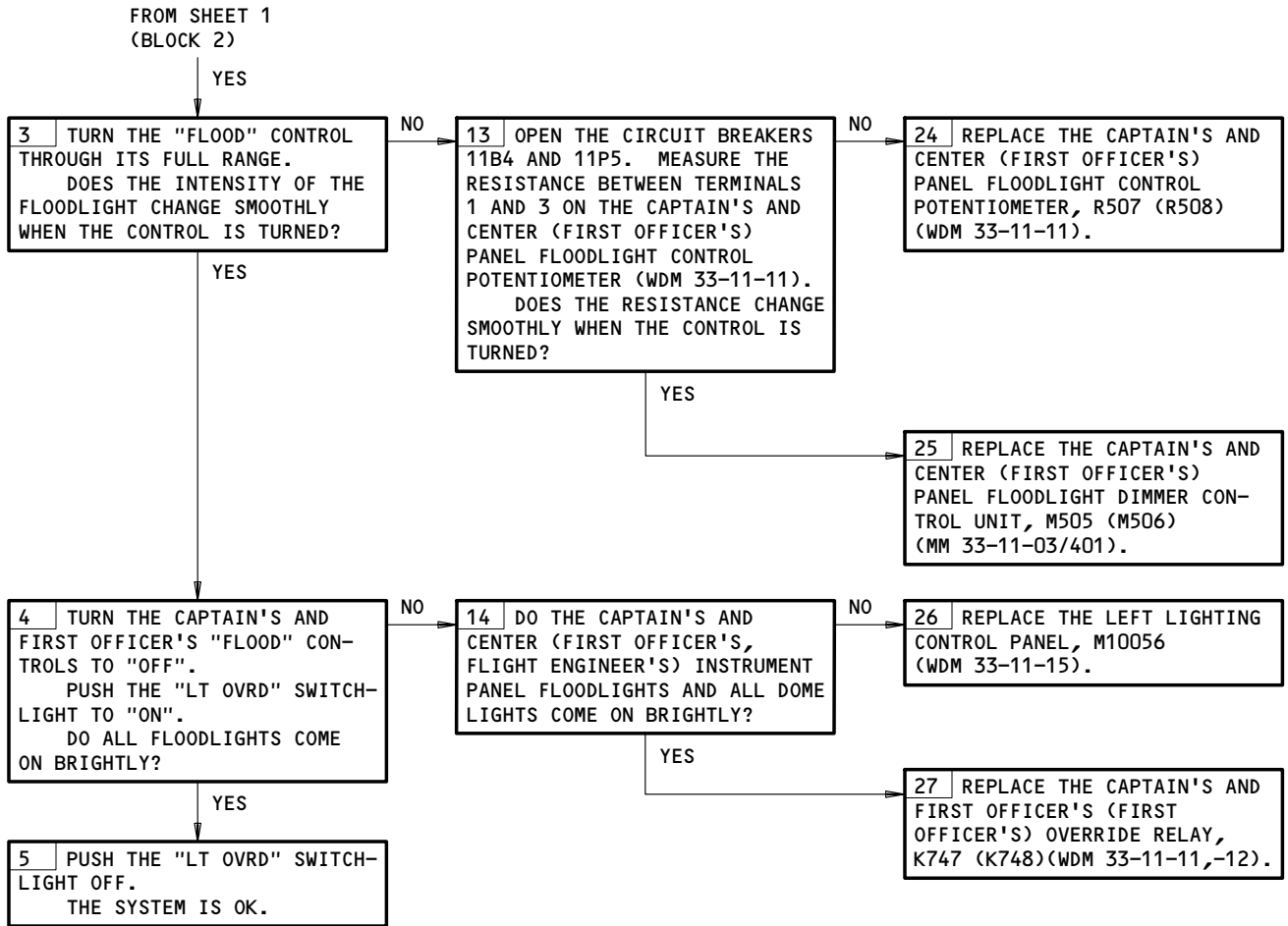

Flight Compartment Panel Floodlight Problems
Figure 103 (Sheet 2)

EFFECTIVITY

ALL

33-11-00

**FLIGHT COMPARTMENT
GLARESHIELD FLOOD-
LIGHT PROBLEMS**

PREREQUISITES
MAKE SURE THIS CIRCUIT BREAKER IS CLOSED:
11P7
MAKE SURE THE AIRPLANE IS IN THE CONFIGURATION THAT
FOLLOWS:
ELECTRICAL POWER IS ON (MM 24-22-00/201)

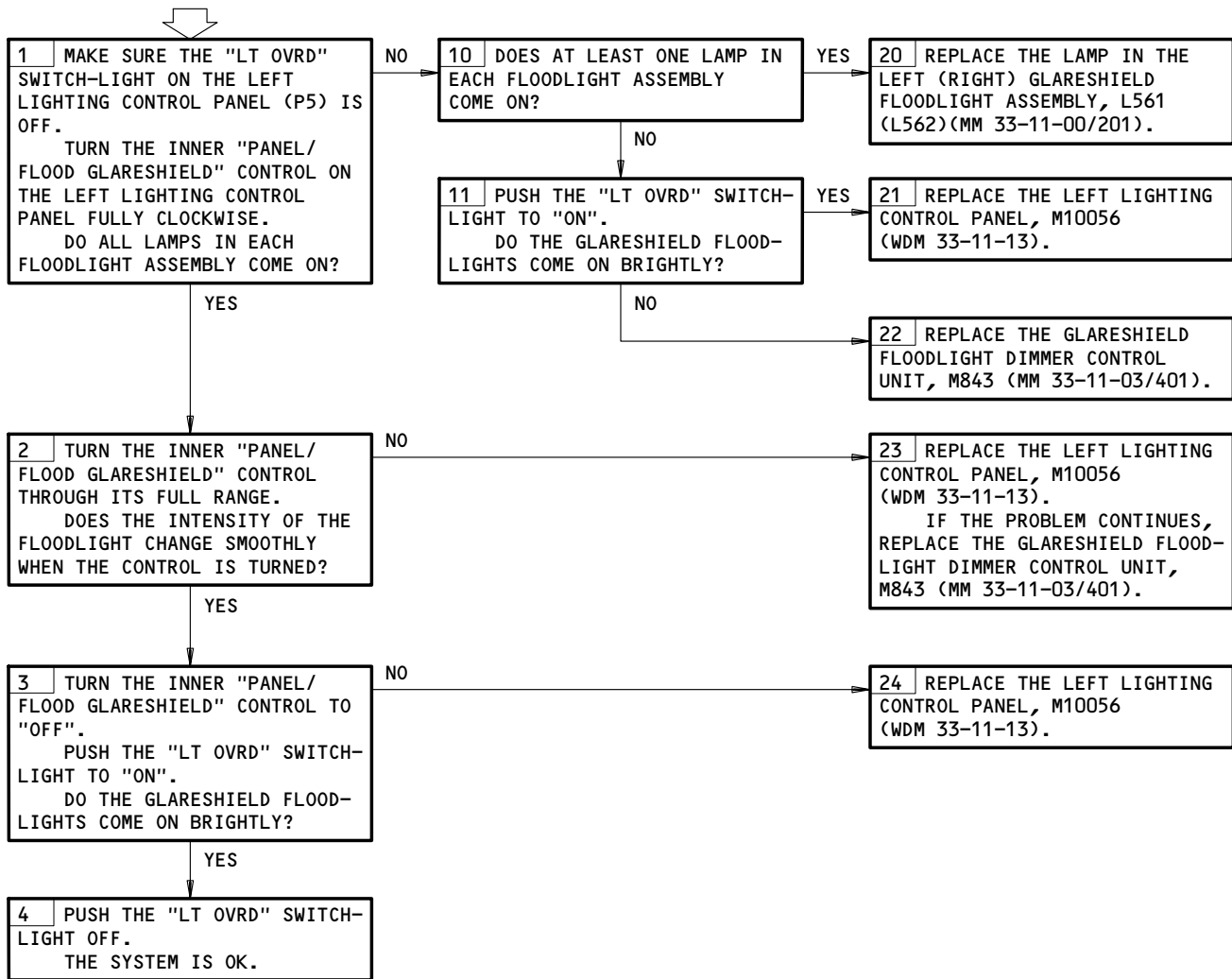

Flight Compartment Glareshield Floodlight Problems
Figure 104

EFFECTIVITY

ALL

33-11-00

01

Page 106
Feb 10/94

309402

**FLIGHT COMPARTMENT
GLARESHIELD FLOOD-
LIGHT PROBLEMS**

PREREQUISITES

MAKE SURE THESE CIRCUIT BREAKERS ARE CLOSED:
11B5,11P2

MAKE SURE THE AIRPLANE IS IN THE CONFIGURATION THAT
FOLLOWS:

ELECTRICAL POWER IS ON (MM 24-22-00/201)

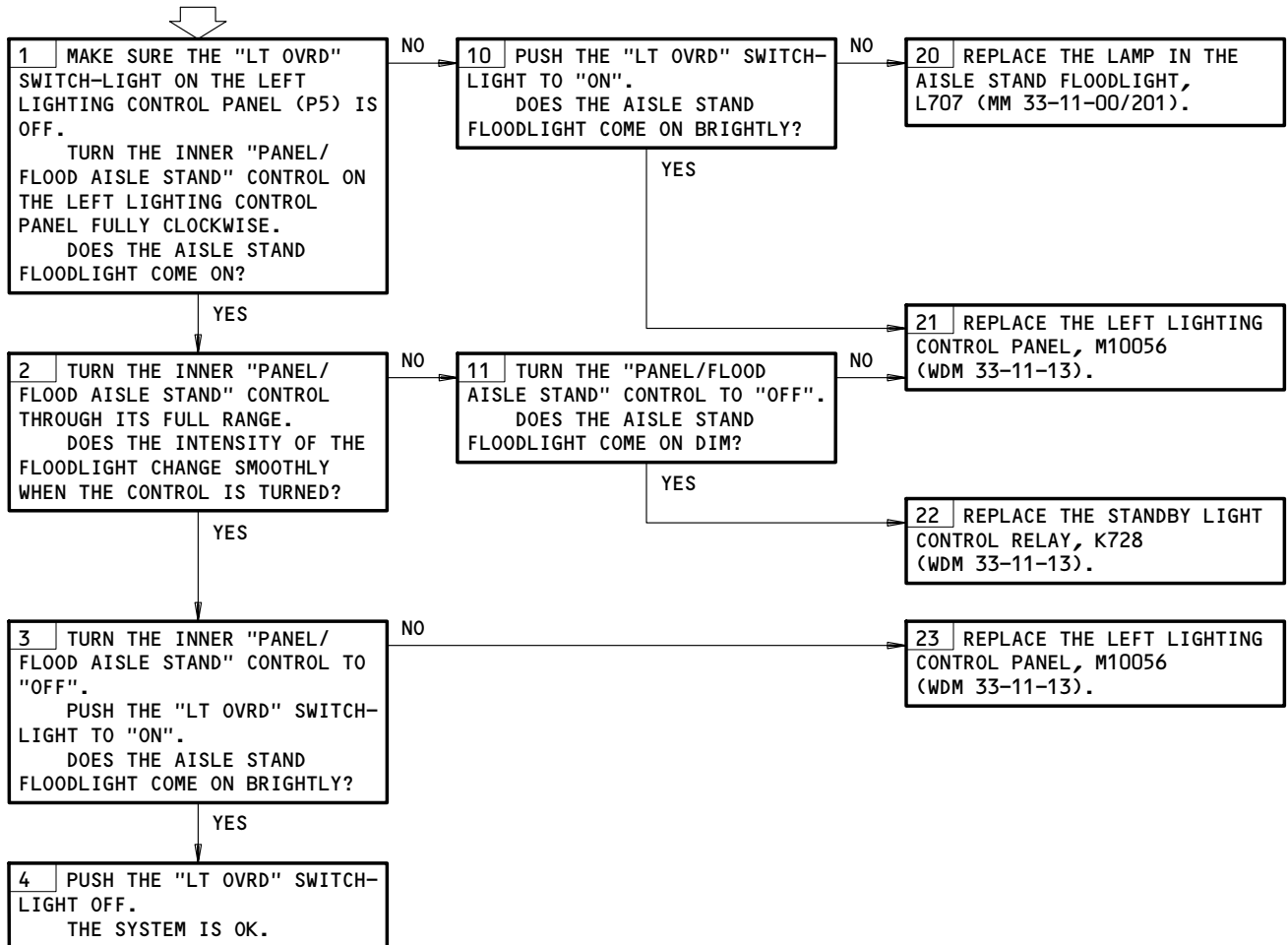

Flight Compartment Glareshield Floodlight Problems
Figure 105

EFFECTIVITY

ALL

33-11-00

01

Page 107
Feb 10/94

**FLIGHT COMPARTMENT
DOME LIGHT PROBLEMS**

PREREQUISITES
 MAKE SURE THESE CIRCUIT BREAKERS ARE CLOSED:
 11B4,11P5,33K7
 MAKE SURE THE AIRPLANE IS IN THE CONFIGURATION THAT
 FOLLOWS:
 ELECTRICAL POWER IS ON (MM 24-22-00/201)

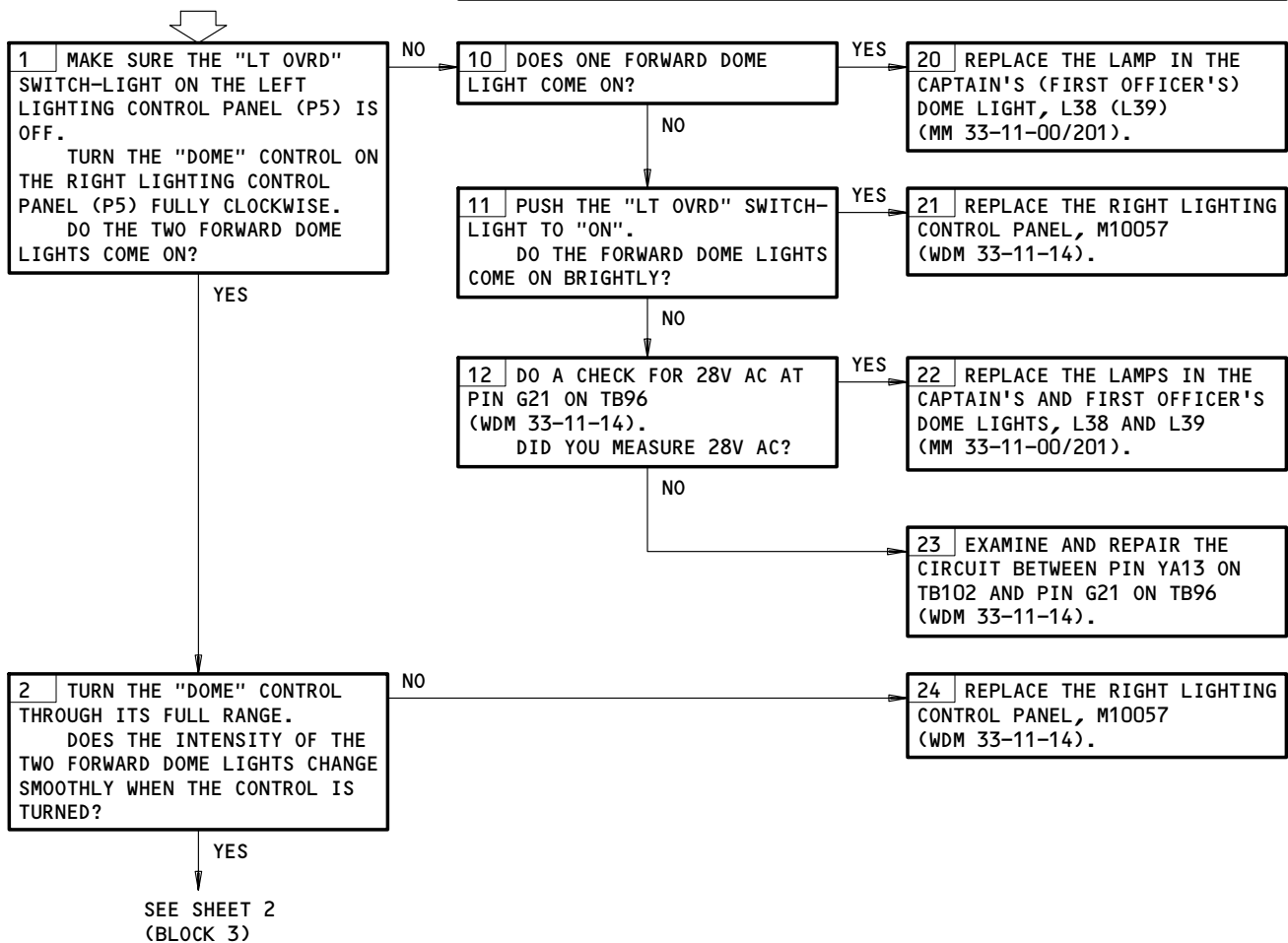

Flight Compartment Dome Light Problems
Figure 106 (Sheet 1)

EFFECTIVITY
 AIRPLANES WITH A DOME LIGHTS SWITCH
 ON THE P5 AND P61 PANELS

33-11-00

46399

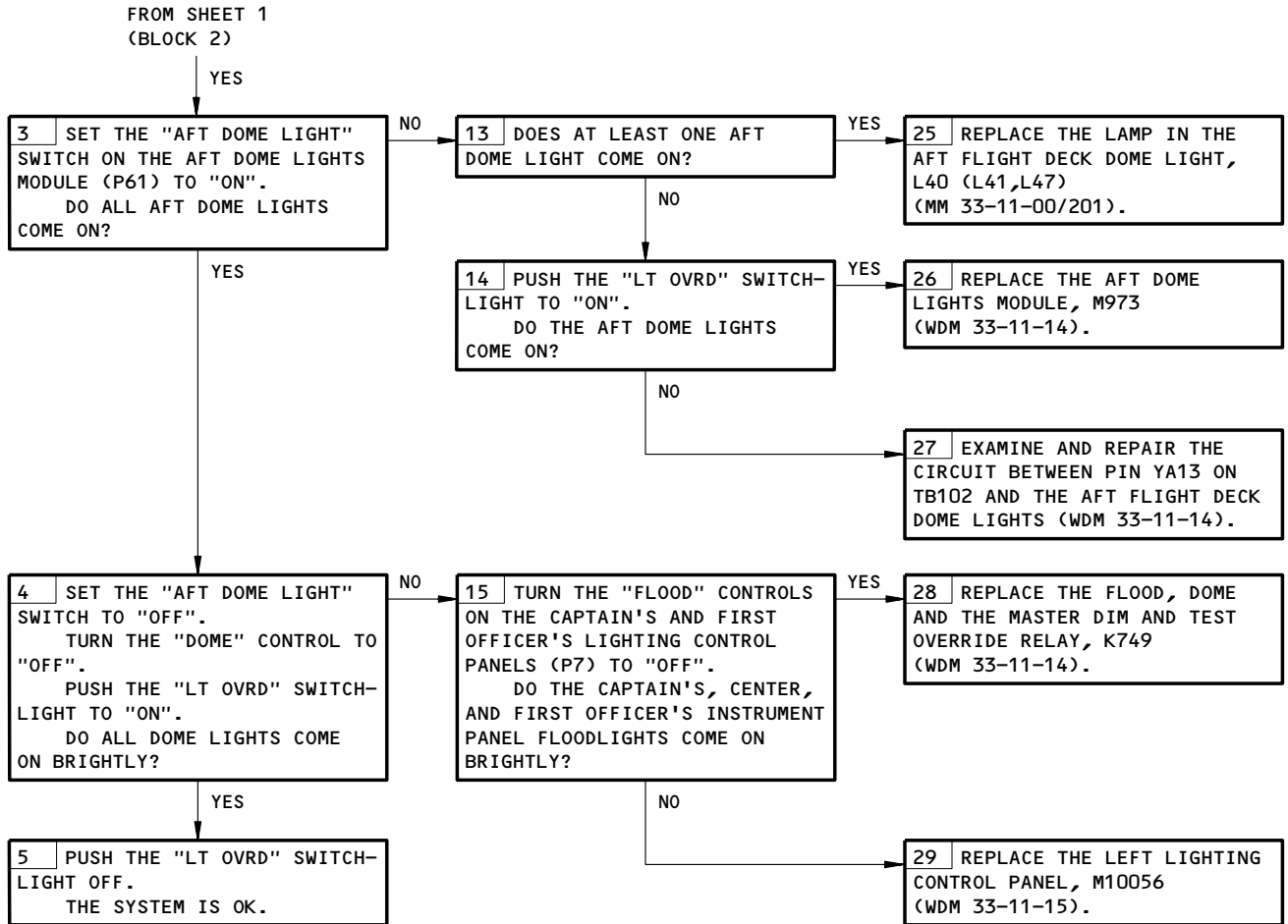

Flight Compartment Dome Light Problems
Figure 106 (Sheet 2)

EFFECTIVITY
 AIRPLANES WITH A DOMES LIGHTS SWITCH
 ON THE P5 AND P61 PANELS

33-11-00

**FLIGHT COMPARTMENT
DOME LIGHT PROBLEMS**

PREREQUISITES
 MAKE SURE THESE CIRCUIT BREAKERS ARE CLOSED:
 11B4, 11P5, 33K7
 MAKE SURE THE AIRPLANE IS IN THE CONFIGURATION THAT
 FOLLOWS:
 ELECTRICAL POWER IS ON (MM 24-22-00/201)

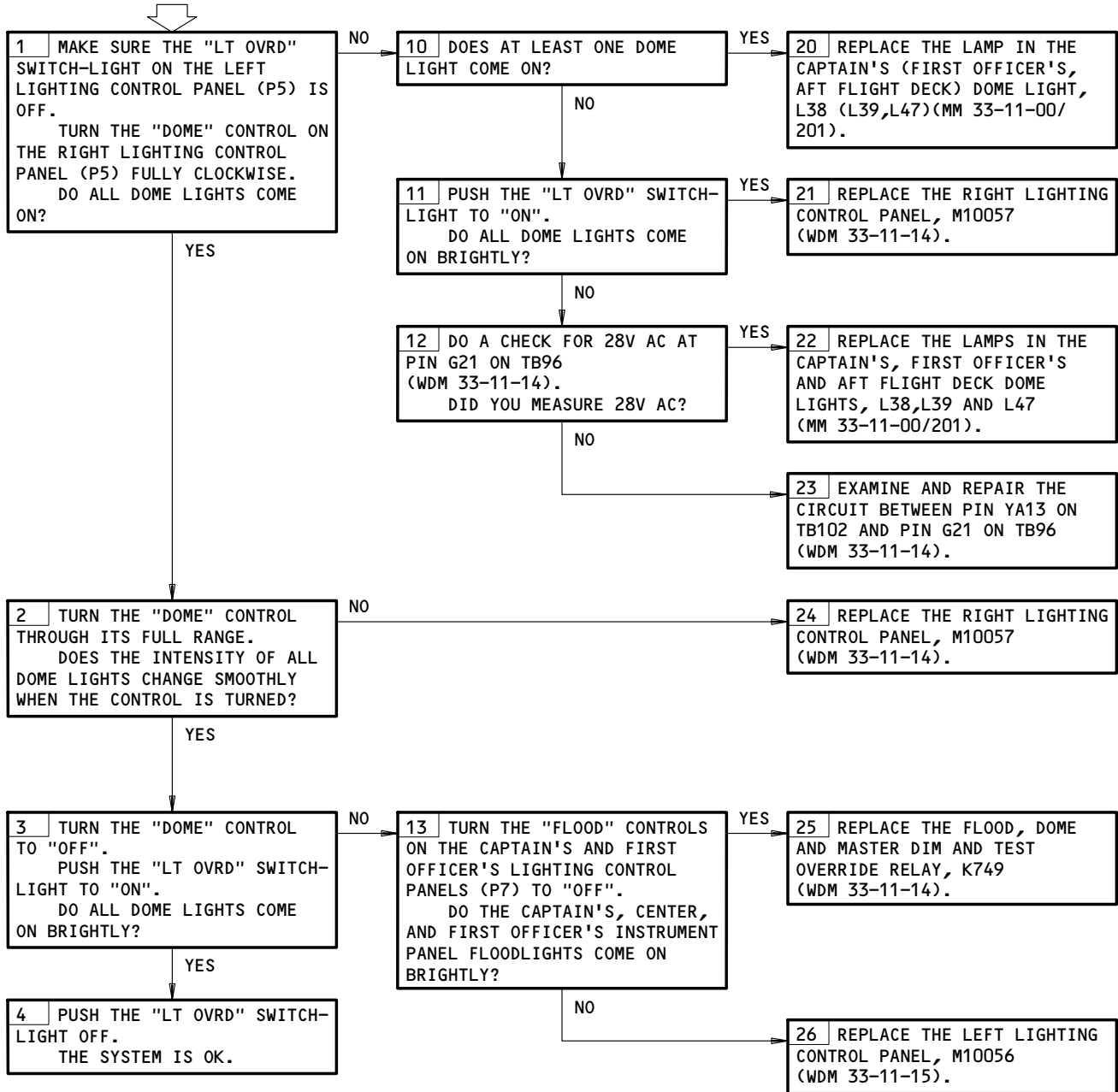

Flight Compartment Dome Light Problems
Figure 106 (Sheet 3)

EFFECTIVITY
 AIRPLANES WITH ONLY A SWITCH
 ON THE P5 PANEL

33-11-00

**FLIGHT COMPARTMENT
MAIN POWER DISTRI-
BUTION PANEL (P6)
FLOODLIGHT PROBLEMS**

PREREQUISITES

MAKE SURE THIS CIRCUIT BREAKER IS CLOSED:
11P31

MAKE SURE THE AIRPLANE IS IN THE CONFIGURATION THAT
FOLLOWS:

ELECTRICAL POWER IS ON (MM 24-22-00/201)

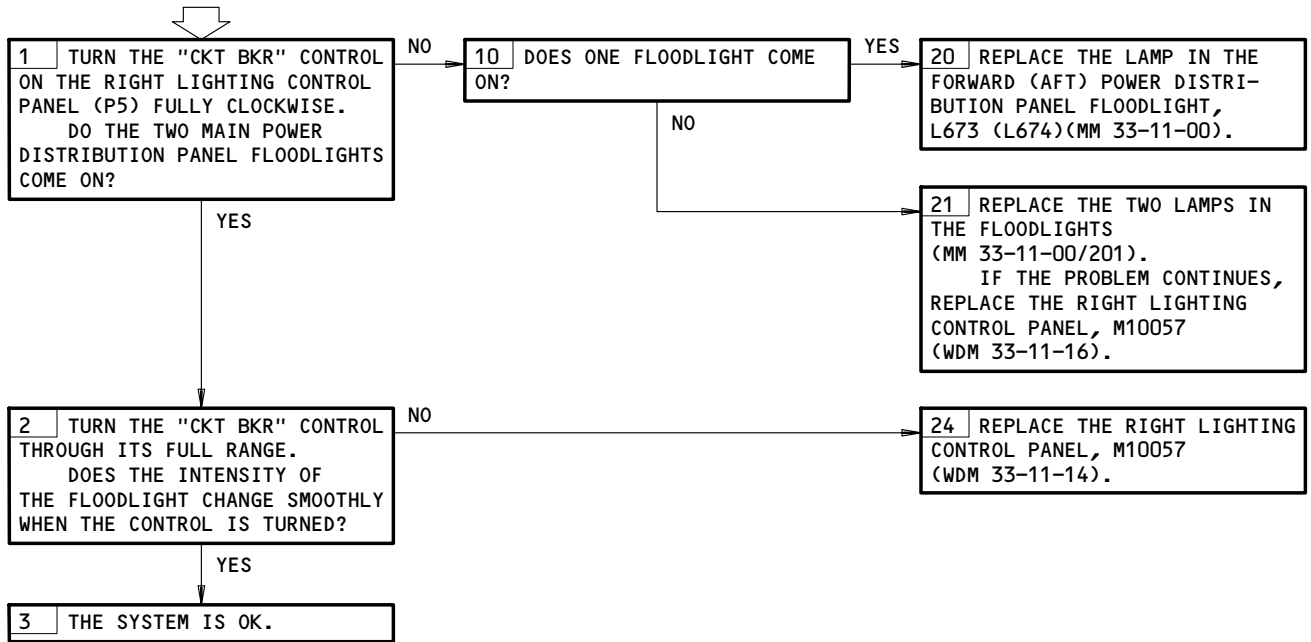

Flight Compartment Main Power Distribution Panel (P6) Floodlight Problems
Figure 107

EFFECTIVITY

ALL

33-11-00

01

Page 111
Feb 10/94

61039



BOEING
 767
 FAULT ISOLATION/MAINT MANUAL

INTEGRAL PANEL LIGHTS

COMPONENT*	FIG. 102 SHT	QTY *	ACCESS/AREA	AMM REFERENCE
CIRCUIT BREAKER - DIMMER CONTROL UNIT - LIGHT - CIRCUIT BREAKER PANEL INSTRUMENT AND PANEL RELAY - SWITCH - LIGHT	--		FLT COMPT, P11	
	1		FLT COMPT	33-13-02
			FLT COMPT	*
			FLT COMPT	*
	2		FLT COMPT, P5 AND P7	*

* SEE THE SSM OR WDM FOR THE EQUIPMENT NUMBER, QUANTITY AND LOCATION OF EACH COMPONENT IN THE LIGHTING CIRCUIT.

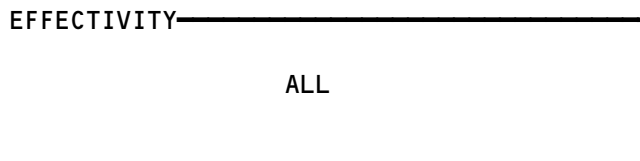
Integral Panel Lights - Component Index
Figure 101



33-13-00

01

Page 101
Feb 10/94

D20235

BOEING
767
FAULT ISOLATION/MAINT MANUAL

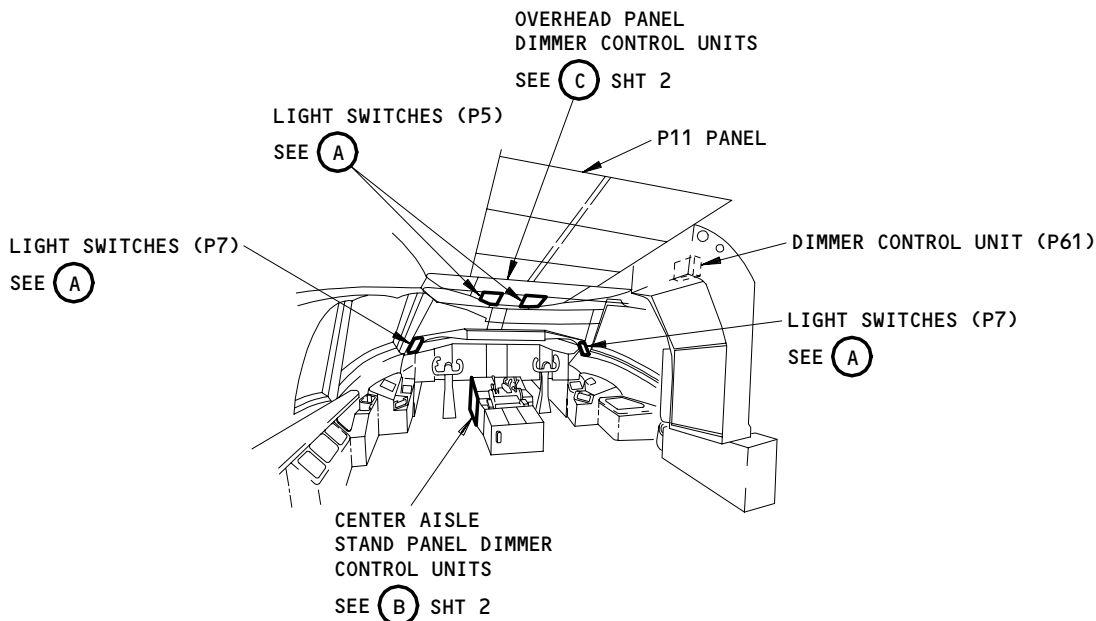

FLIGHT COMPARTMENT

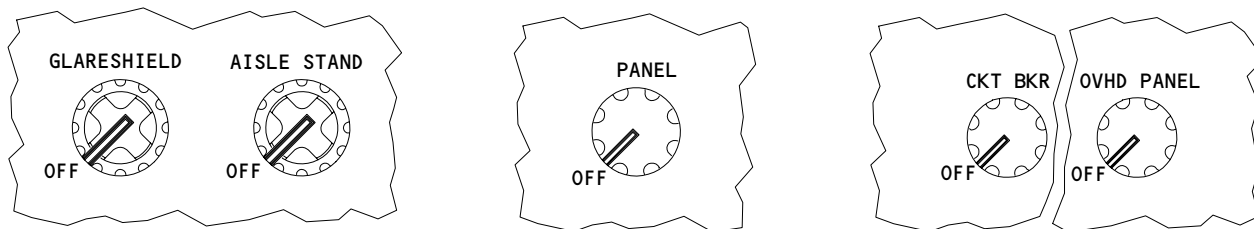

LIGHT SWITCHES
(EXAMPLE)

(A)

Integral Panel Lights - Component Location
Figure 102 (Sheet 1)

EFFECTIVITY	ALL
-------------	-----

33-13-00

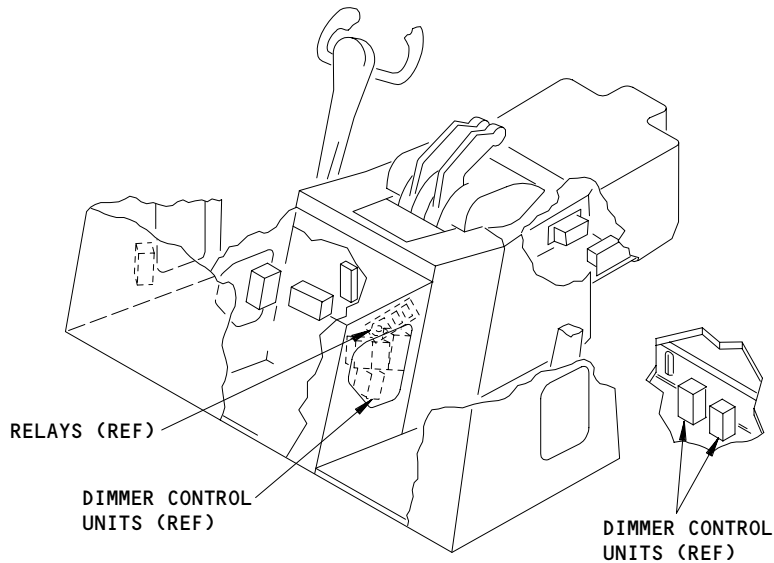

CENTER AISLE STAND
PANEL DIMMER CONTROL UNITS

(B)

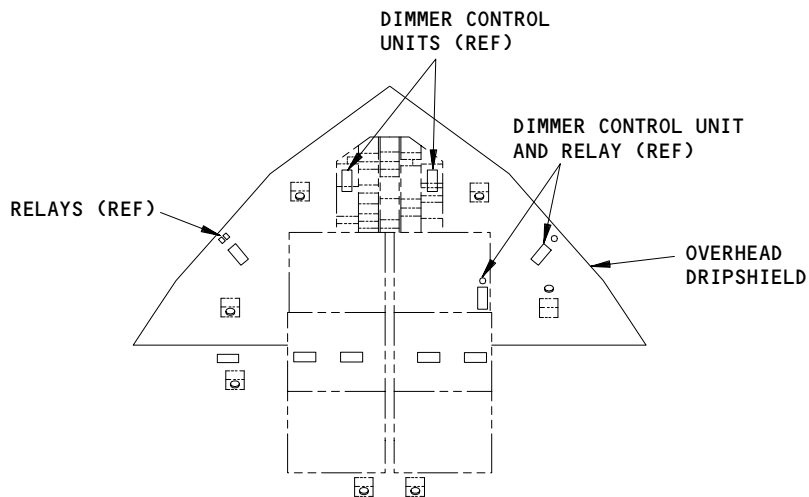

OVERHEAD PANEL DIMMER CONTROL UNITS

(C)

Integral Panel Lights - Component Location (Details from Sht 1)
Figure 102 (Sheet 2)

EFFECTIVITY	
	ALL

33-13-00

**FLIGHT COMPARTMENT –
CAPTAIN'S AND
CENTER PANEL LIGHT
PROBLEMS**

PREREQUISITES
ELECTRICAL POWER (MM 24-22-00)
CB'S: 11B7,11P2

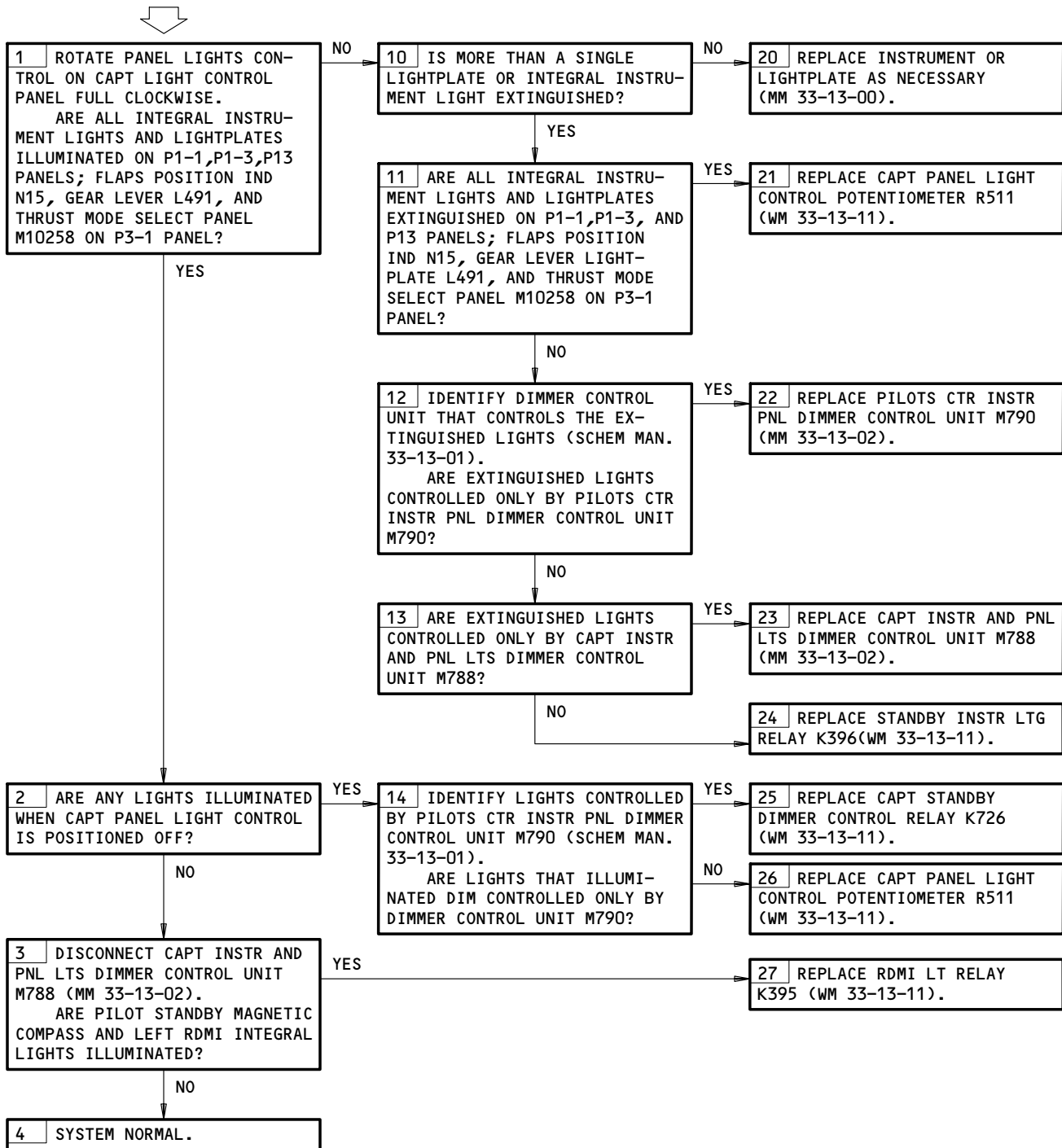

Flight Compartment - Captain's and Center Panel Light Problems
Figure 103

EFFECTIVITY

ALL

33-13-00

01

Page 104
Feb 10/94

**FLIGHT COMPARTMENT
FIRST OFFICER'S
PANEL LIGHT
PROBLEMS**

PREREQUISITES
ELECTRICAL POWER (MM 24-22-00)
CB'S: 11P2,11P28

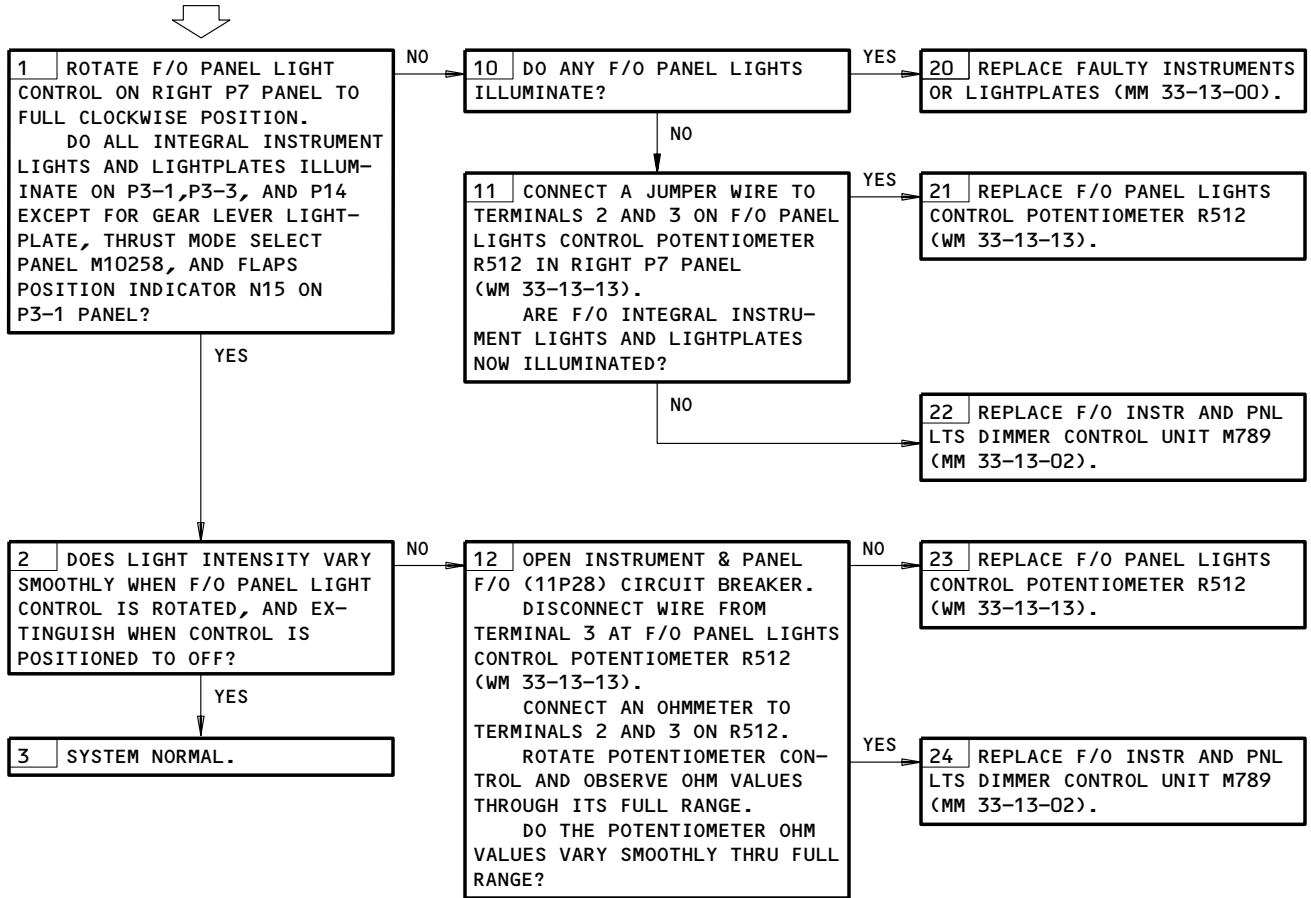

Flight Compartment - First Officer's Panel Light Problems
Figure 104

EFFECTIVITY

ALL

33-13-00

01

Page 105
Feb 10/94

48490

**FLIGHT COMPARTMENT –
OVERHEAD PANEL
LIGHT PROBLEMS**

PREREQUISITES
MAKE SURE EACH APPLICABLE CIRCUIT BREAKER IS CLOSED:
(SSM 33-13-01 OR WDM 33-13-16)
MAKE SURE THE AIRPLANE IS IN THIS CONFIGURATION:
ELECTRICAL POWER IS ON (AMM 24-22-00/201)

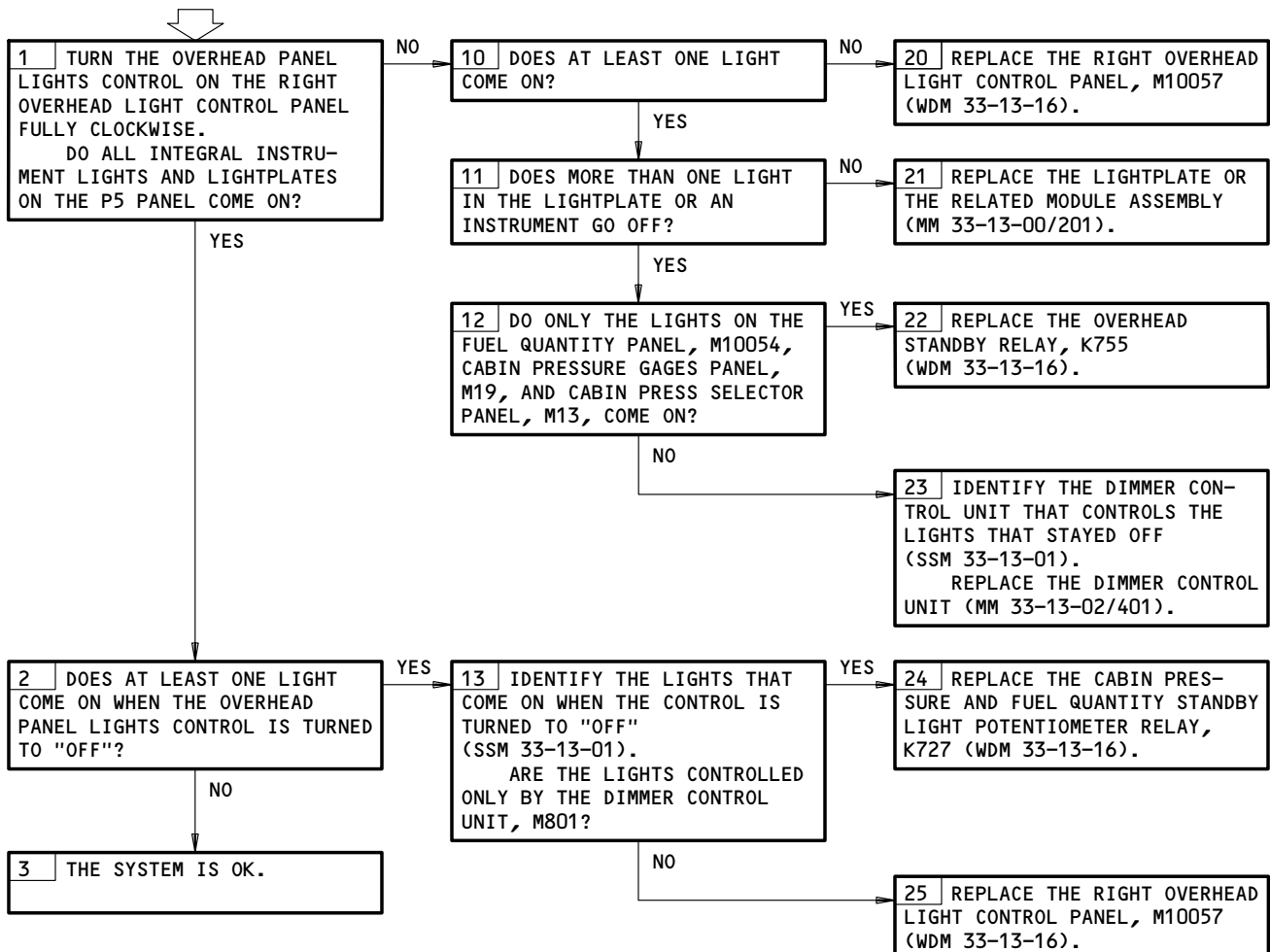

Flight Compartment – Overhead Panel Light Problems
Figure 105

EFFECTIVITY

ALL

33-13-00

01

Page 106
Nov 10/95

314040

**FLIGHT COMPARTMENT -
GLARESHIELD PANEL
LIGHT PROBLEMS**

PREREQUISITES
ELECTRICAL POWER (MM 24-22-00)
CB'S: 11B7,11P2,11P30

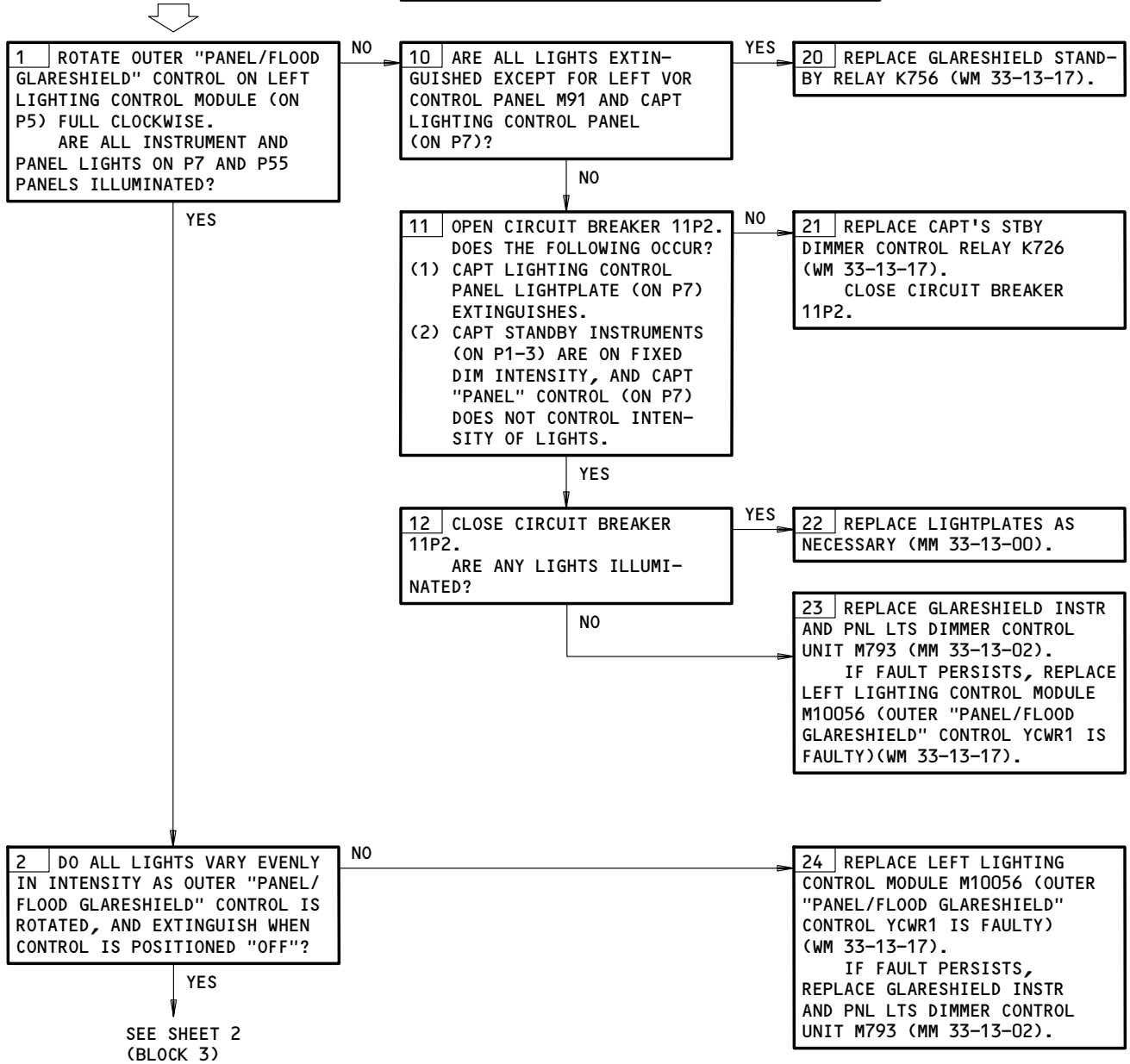

Flight Compartment - Glareshield Panel Light Problems
Figure 106 (Sheet 1)

EFFECTIVITY	ALL
--------------------	-----

33-13-00

FROM SHEET 1
(BLOCK 2)

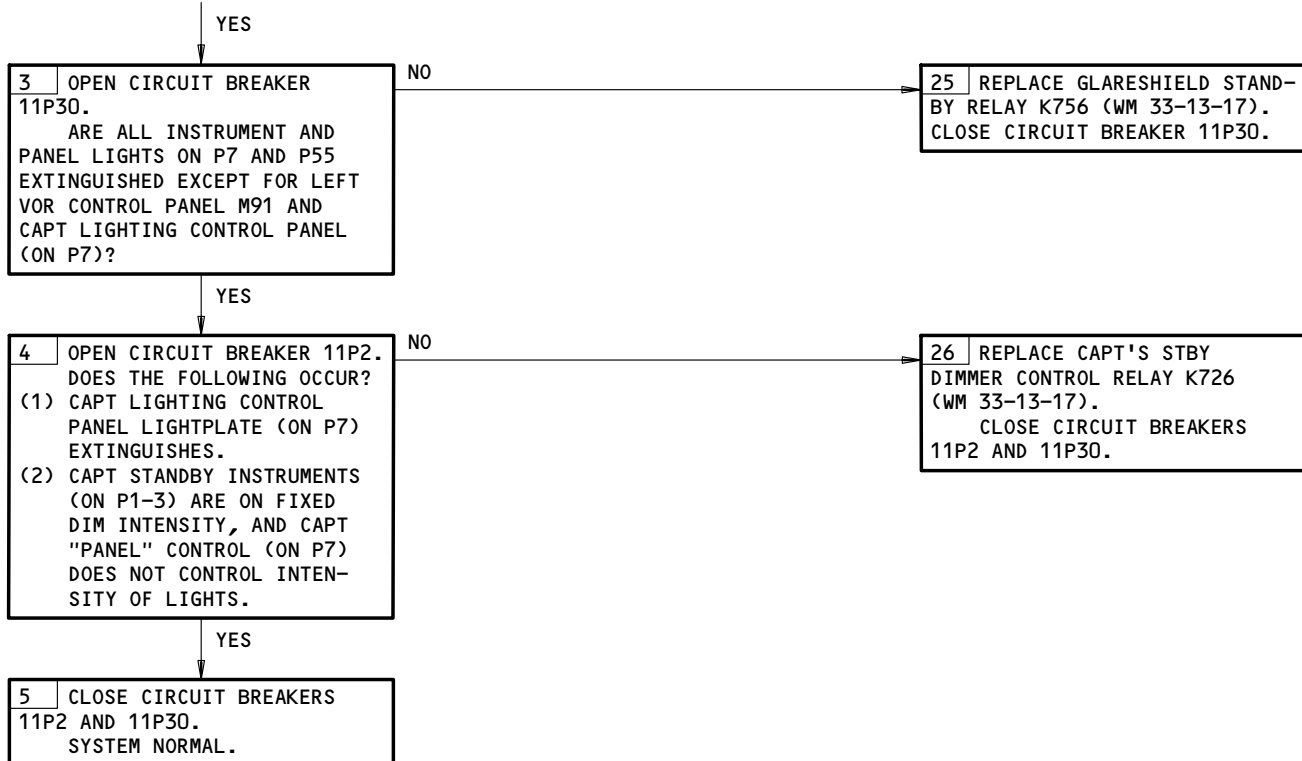

Flight Compartment - Glareshield Panel Light Problems
Figure 106 (Sheet 2)

EFFECTIVITY	ALL
-------------	-----

33-13-00

**FLIGHT COMPARTMENT -
AISLE STAND/OVERHEAD
CB PANEL LIGHT
PROBLEMS**

PREREQUISITES
MAKE SURE EACH APPLICABLE CIRCUIT BREAKER IS CLOSED:
(SSM 33-13-01 OR WDM 33-13-18 THRU 33-13-19)
MAKE SURE THE AIRPLANE IS IN THIS CONFIGURATION:
ELECTRICAL POWER IS ON (AMM 24-22-00/201)

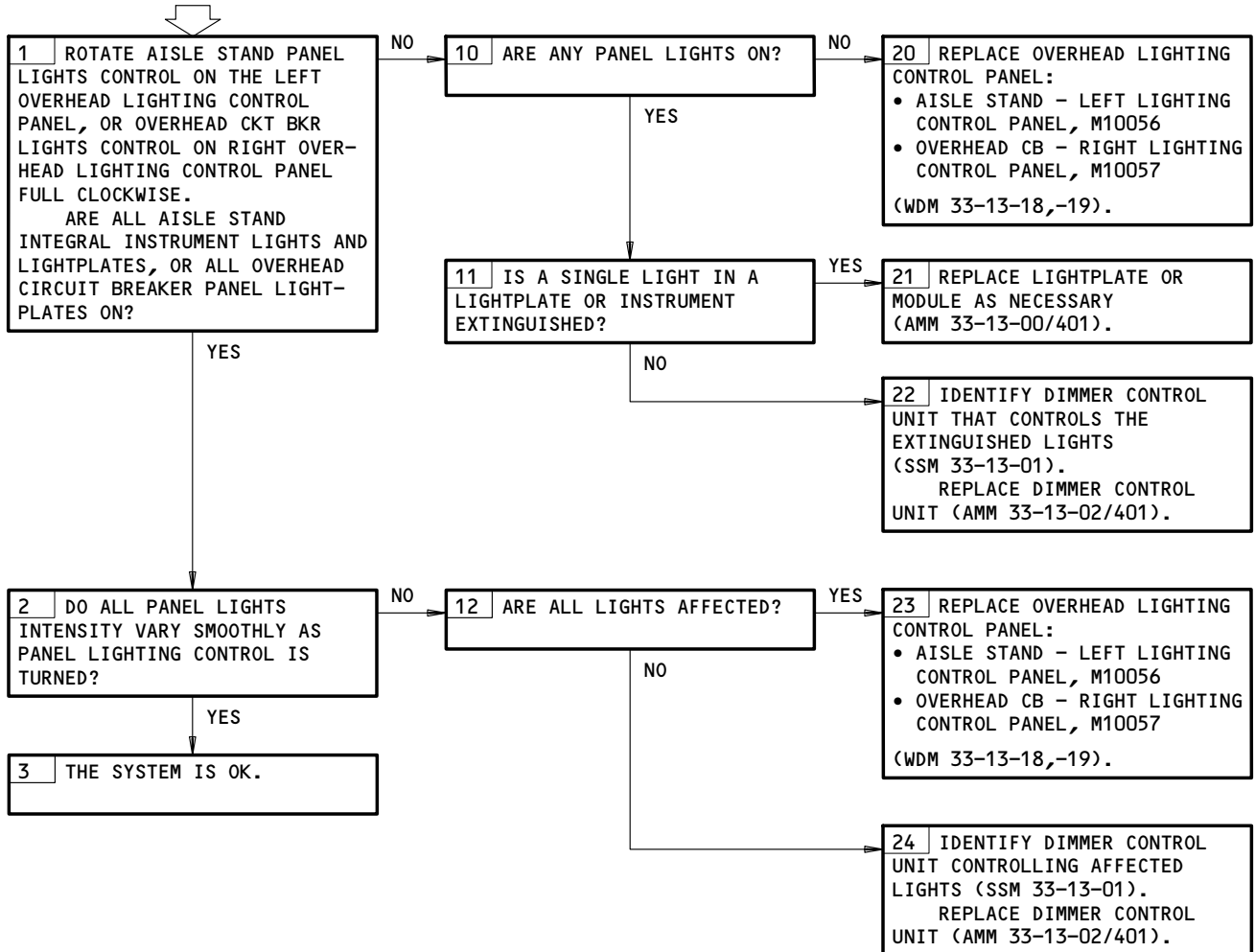

Flight Compartment - Aisle Stand/Overhead CB Panel Light Problems
Figure 107

EFFECTIVITY	ALL
-------------	-----

33-13-00

314036

**FLIGHT COMPARTMENT -
RIGHT SIDE PANEL
LIGHT PROBLEMS**

PREREQUISITES
ELECTRICAL POWER (MM 24-22-00)
CB'S: 11P28

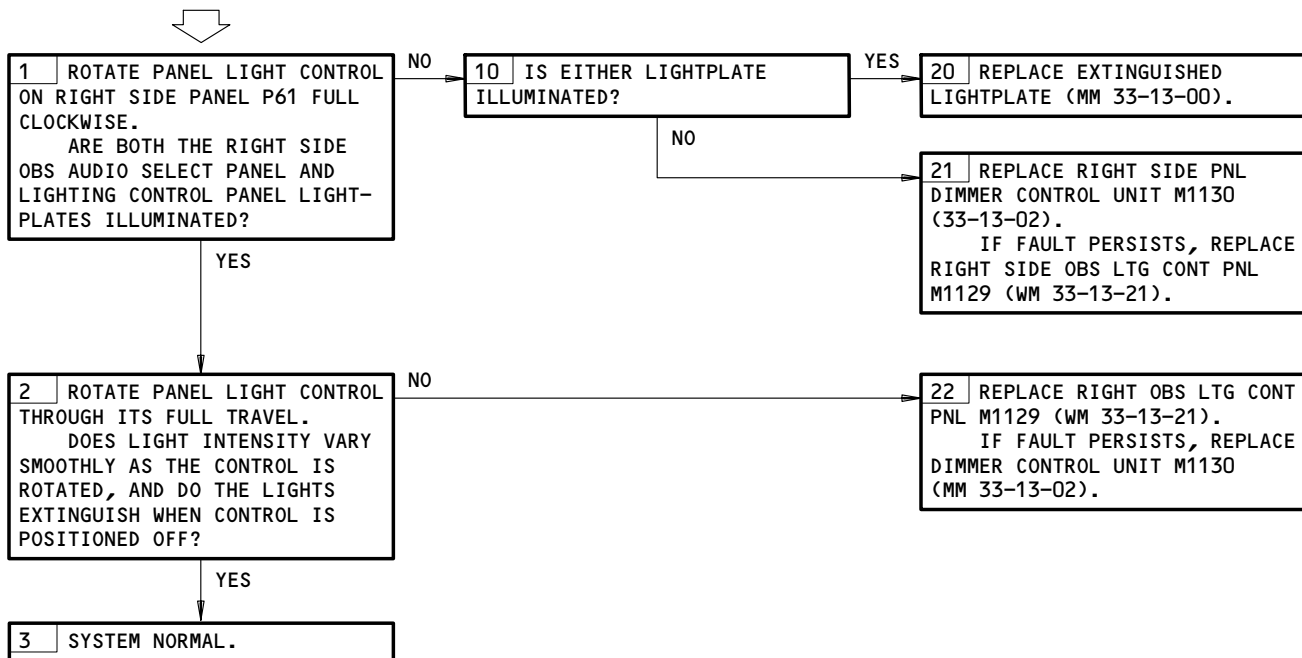

Flight Compartment - Right Side Panel Light Problems
Figure 108

EFFECTIVITY
AIRPLANES WITH PANEL LIGHTS ON THE RIGHT
SIDE PANEL

33-13-00



767
 FAULT ISOLATION/MAINT MANUAL

FLIGHT COMPARTMENT MISCELLANEOUS LIGHTS

COMPONENT*	FIG. 102 SHT	QTY *	ACCESS/AREA	AMM REFERENCE
BOX - SPARE LAMP	2		FLT COMPT	*
CIRCUIT BREAKER - LIGHT -	--		FLT COMPT, P11	*
CHART	1		FLT COMPT	33-14-00
FLIGHT KIT	1		FLT COMPT	33-14-00
MAP	1		FLT COMPT	33-14-00
NOTE PAD 	1		FLT COMPT	33-14-00
UTILITY	1		FLT COMPT	33-14-00
SWITCH -	1		FLT COMPT	*

* SEE THE SSM OR WDM FOR THE EQUIPMENT NUMBER, QUANTITY AND LOCATION OF EACH COMPONENT IN THE LIGHTING CIRCUIT.

 NOT INSTALLED ON ALL AIRPLANES

Flight Compartment Miscellaneous Lights - Component Index
 Figure 101

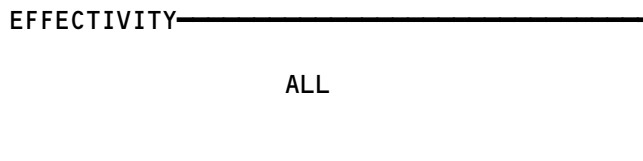

33-14-00

BOEING

767

FAULT ISOLATION/MAINT MANUAL

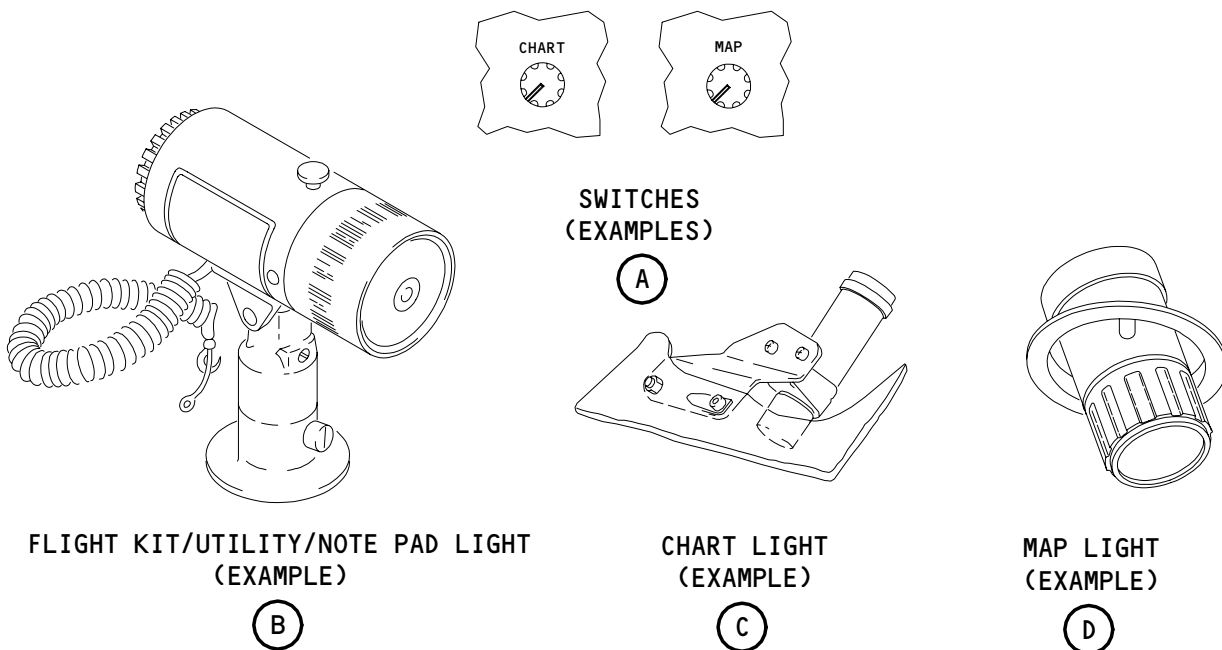
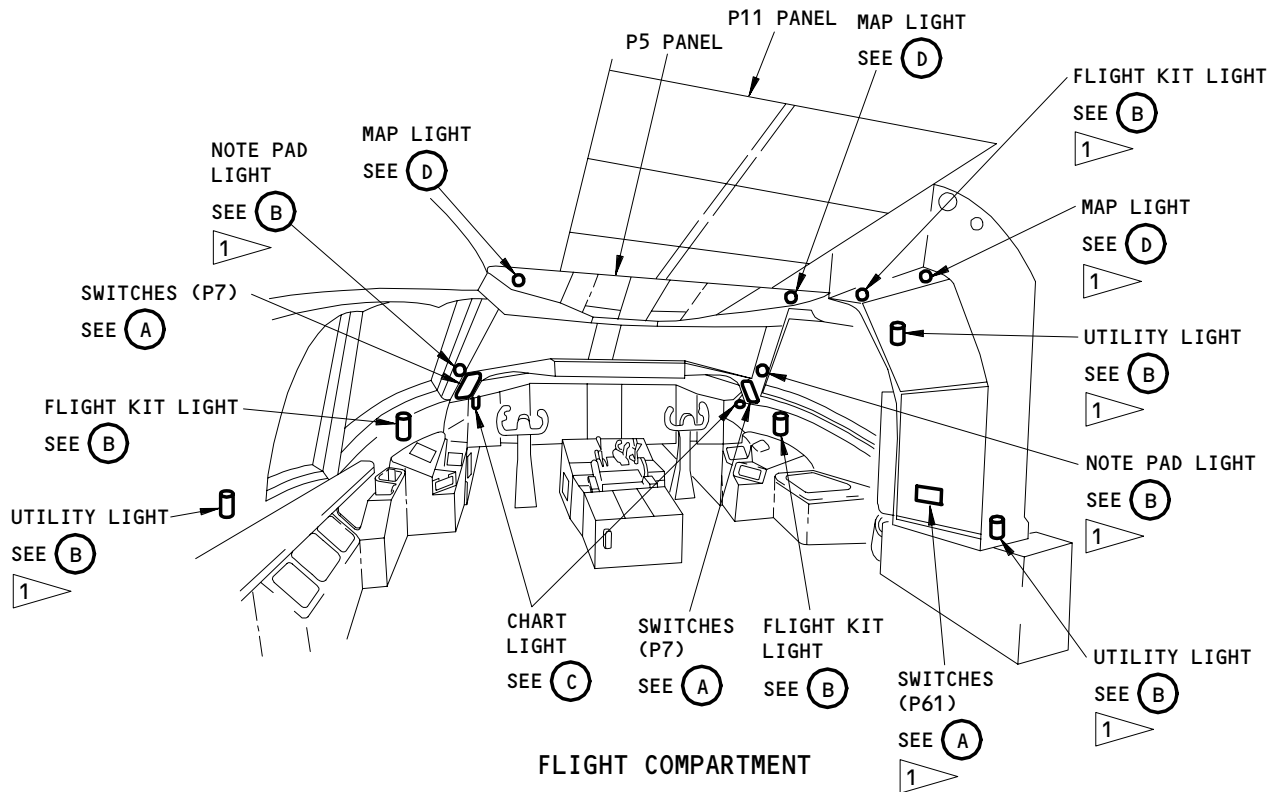

1 NOT INSTALLED ON ALL AIRPLANES

Flight Compartment Miscellaneous Lights - Component Location
Figure 102 (Sheet 1)

EFFECTIVITY	
	ALL

33-14-00

01

Page 102
Aug 10/95

BOEING
767
FAULT ISOLATION/MAINT MANUAL

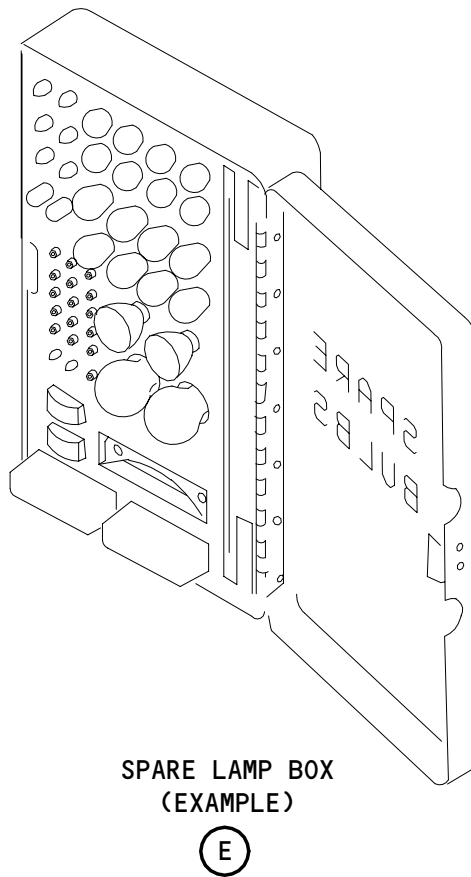
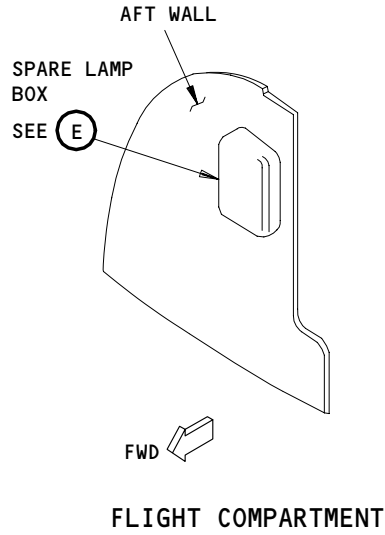

Flight Compartment Miscellaneous Lights - Component Location
Figure 102 (Sheet 2)

EFFECTIVITY	
	ALL

33-14-00

01

Page 103
May 10/94

E15296

**FLIGHT COMPARTMENT
MAP LIGHT PROBLEMS**

PREREQUISITES
MAKE SURE THIS CIRCUIT BREAKER IS CLOSED:
11P31
MAKE SURE THE AIRPLANE IS IN THIS CONFIGURATION:
ELECTRICAL POWER IS ON (AMM 24-22-00/201)

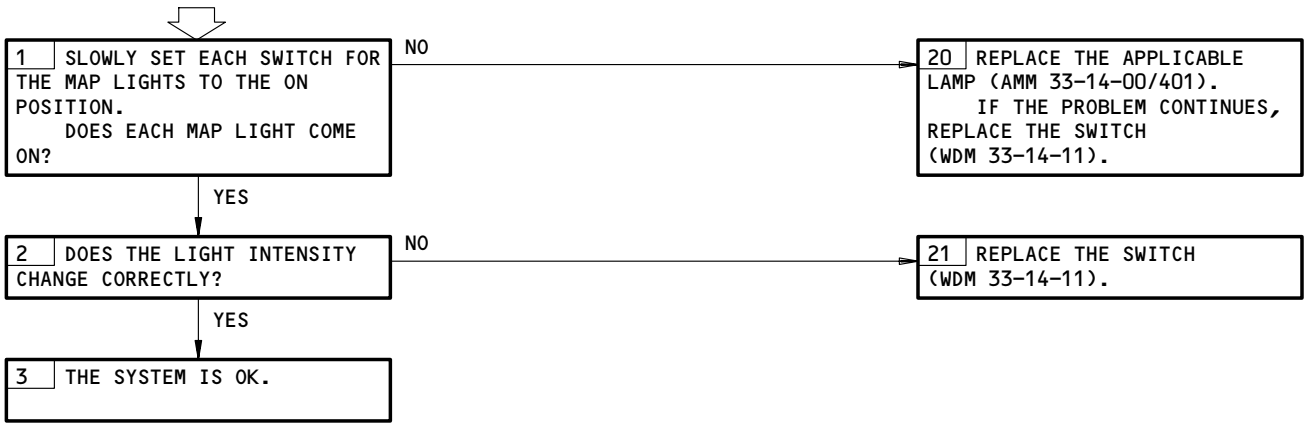

Flight Compartment Map Light Problems
Figure 103

EFFECTIVITY	ALL
-------------	-----

33-14-00

PREREQUISITES

MAKE SURE THIS CIRCUIT BREAKER IS CLOSED:
11P8

MAKE SURE THE AIRPLANE IS IN THIS CONFIGURATION:
ELECTRICAL POWER IS ON (AMM 24-22-00/201)

**FLIGHT COMPARTMENT
CHART LIGHT PROBLEMS**

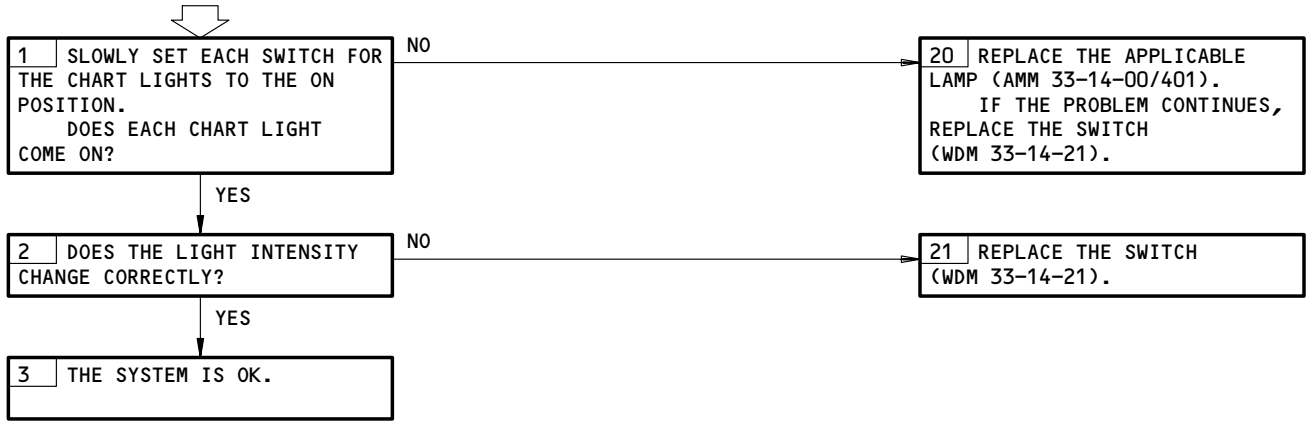

Flight Compartment Chart Light Problems
Figure 104

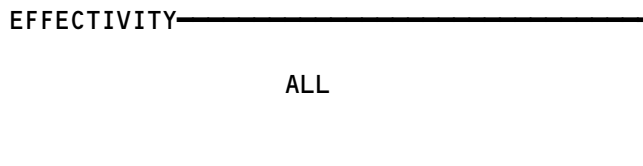

33-14-00

FLIGHT COMPARTMENT
 FLT KIT/UTILITY/
 NOTE PAD LIGHT
 PROBLEMS

PREREQUISITES
 ELECTRICAL POWER (MM 24-22-00)
 CB: 11P32



Flight Compartment Flt Kit/Utility/Note Pad Light Problems
 Figure 105

EFFECTIVITY	ALL
-------------	-----

33-14-00



BOEING
 767
 FAULT ISOLATION/MAINT MANUAL

MASTER DIM AND TEST

COMPONENT*	FIG. 102 SHT	QTY *	ACCESS/AREA	AMM REFERENCE
CARD -				
DIMMER PC	2		119AL, MAIN EQUIP CTR, P29	33-16-01
REVERSE CURRENT BLOCKING DIODE PC	2		119AL, MAIN EQUIP CTR, P29	33-16-01
CIRCUIT BREAKER -	1		FLT COMPT, P6 AND P11	*
RECEPTACLE - SHORTING	1		FLT COMPT, P1-3	*
RELAY -	2		119AL, MAIN EQUIP CTR, P29	*
RELAY -	2		119AL, MAIN EQUIP CTR, P36	*
SENSOR - MASTER DIM AND TEST AUTOBRIGHT	2		FLT COMPT, P1-3	*
SWITCH -				
LIGHT	1		FLT COMPT, P5	*
TEST	1		FLT COMPT, P5	*

* SEE THE SSM OR WDM FOR THE EQUIPMENT NUMBER, QUANTITY AND LOCATION OF EACH COMPONENT IN THE LIGHTING CIRCUIT.

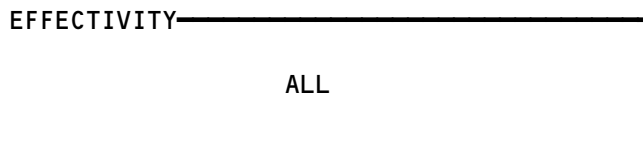
Master Dim and Test - Component Index
Figure 101



33-16-00

BOEING
767
FAULT ISOLATION/MAINT MANUAL

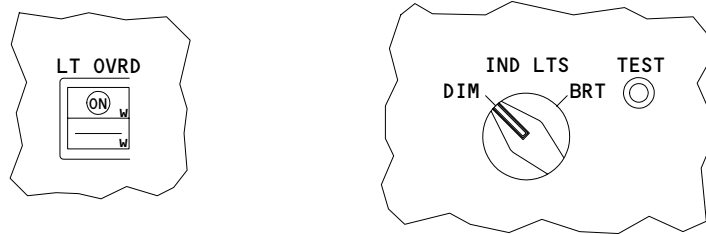
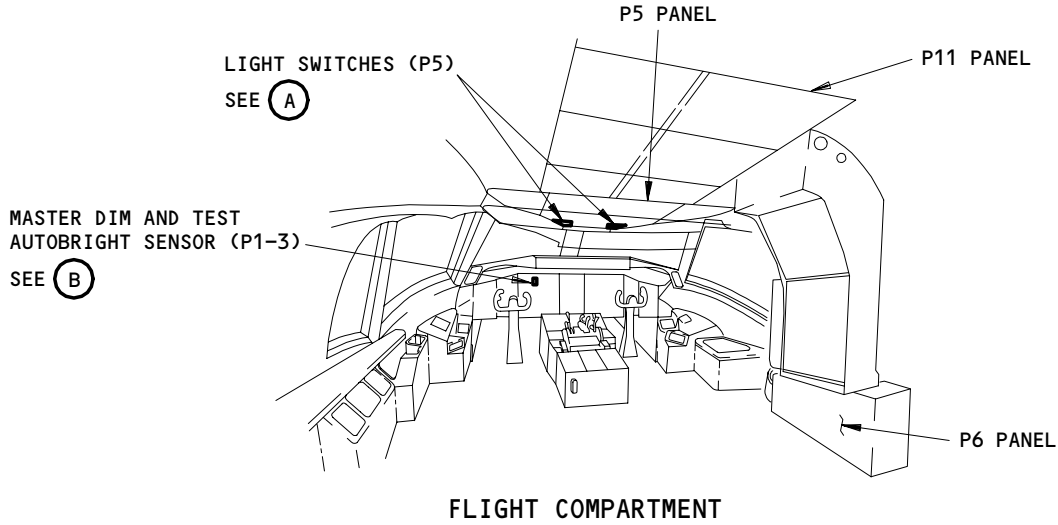

**LIGHT SWITCHES
(EXAMPLE)**

(A)

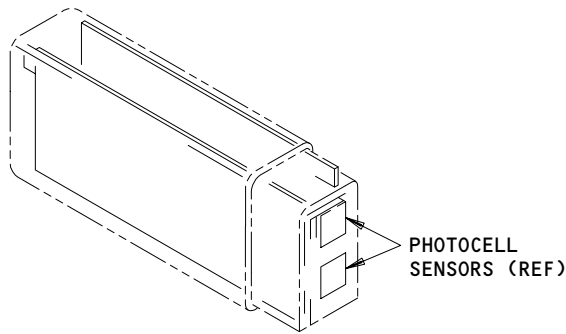

**MASTER DIM AND TEST
AUTOBRIGHT SENSOR, P1-3**

(B)

**Master Dim and Test - Component Location
Figure 102 (Sheet 1)**

EFFECTIVITY	ALL

33-16-00

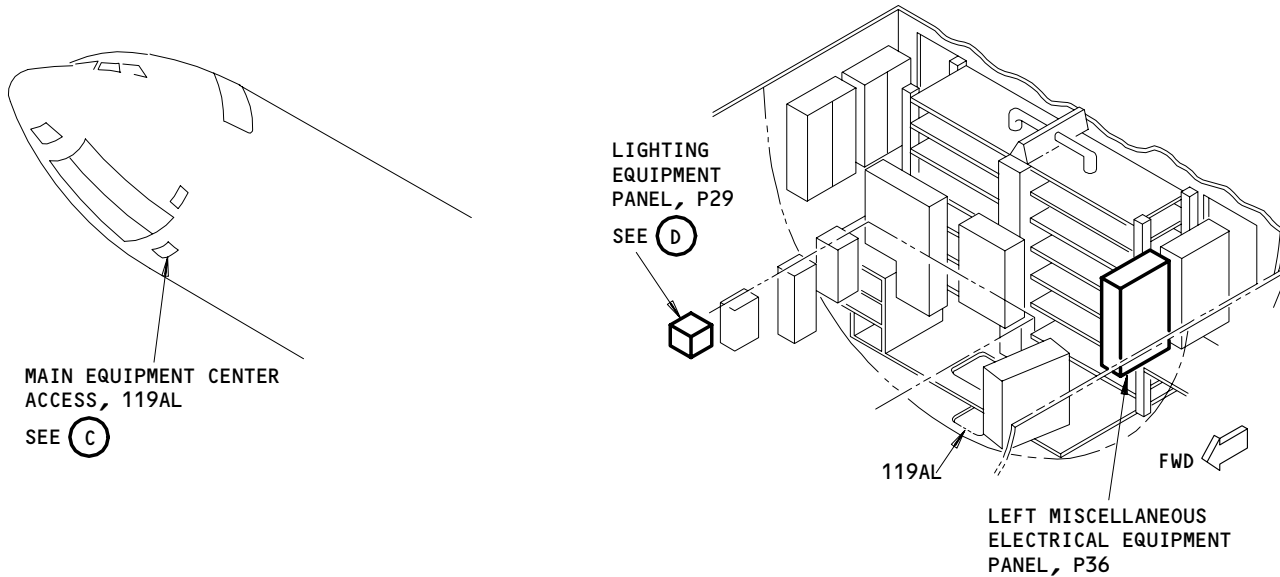

MAIN EQUIPMENT CENTER

(C)

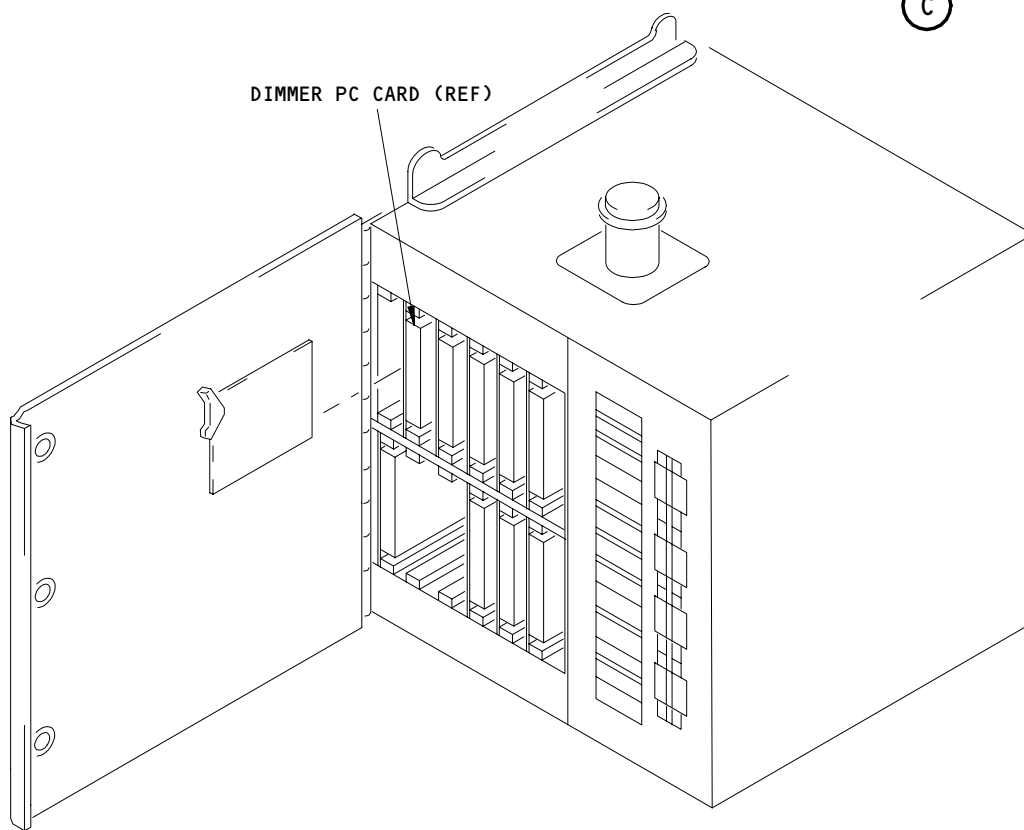

LIGHTING EQUIPMENT PANEL, P29

(D)

Master Dim and Test - Component Location
Figure 102 (Sheet 2)

EFFECTIVITY	
	ALL

33-16-00

**FLIGHT COMPARTMENT
MASTER DIM AND TEST
PROBLEMS**

PREREQUISITES

MAKE SURE THESE SYSTEMS WILL OPERATE:
EFIS (AMM 34-22-00/501)
EICAS (AMM 31-41-00/501)
IRU (AMM 34-21-00/501)

MAKE SURE EACH APPLICABLE CIRCUIT BREAKER IS CLOSED:
(SSM 33-16-01 OR WDM 33-16-11 THRU 33-16-99)

MAKE SURE THE AIRPLANE IS IN THIS CONFIGURATION:
ELECTRICAL POWER IS ON (AMM 24-22-00/201)

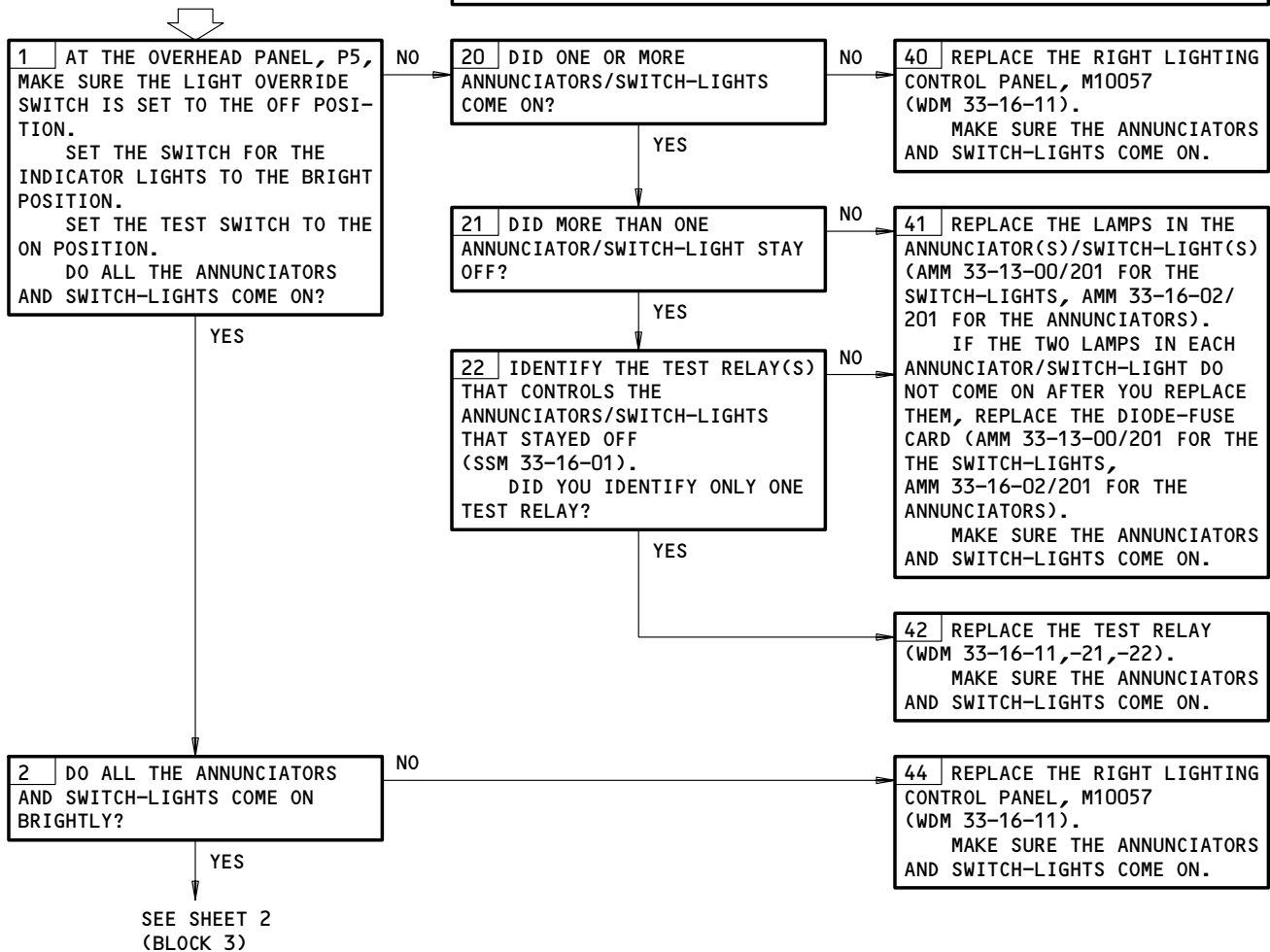

Flight Compartment Master Dim and Test Problems
Figure 103 (Sheet 1)

EFFECTIVITY

ALL

33-16-00

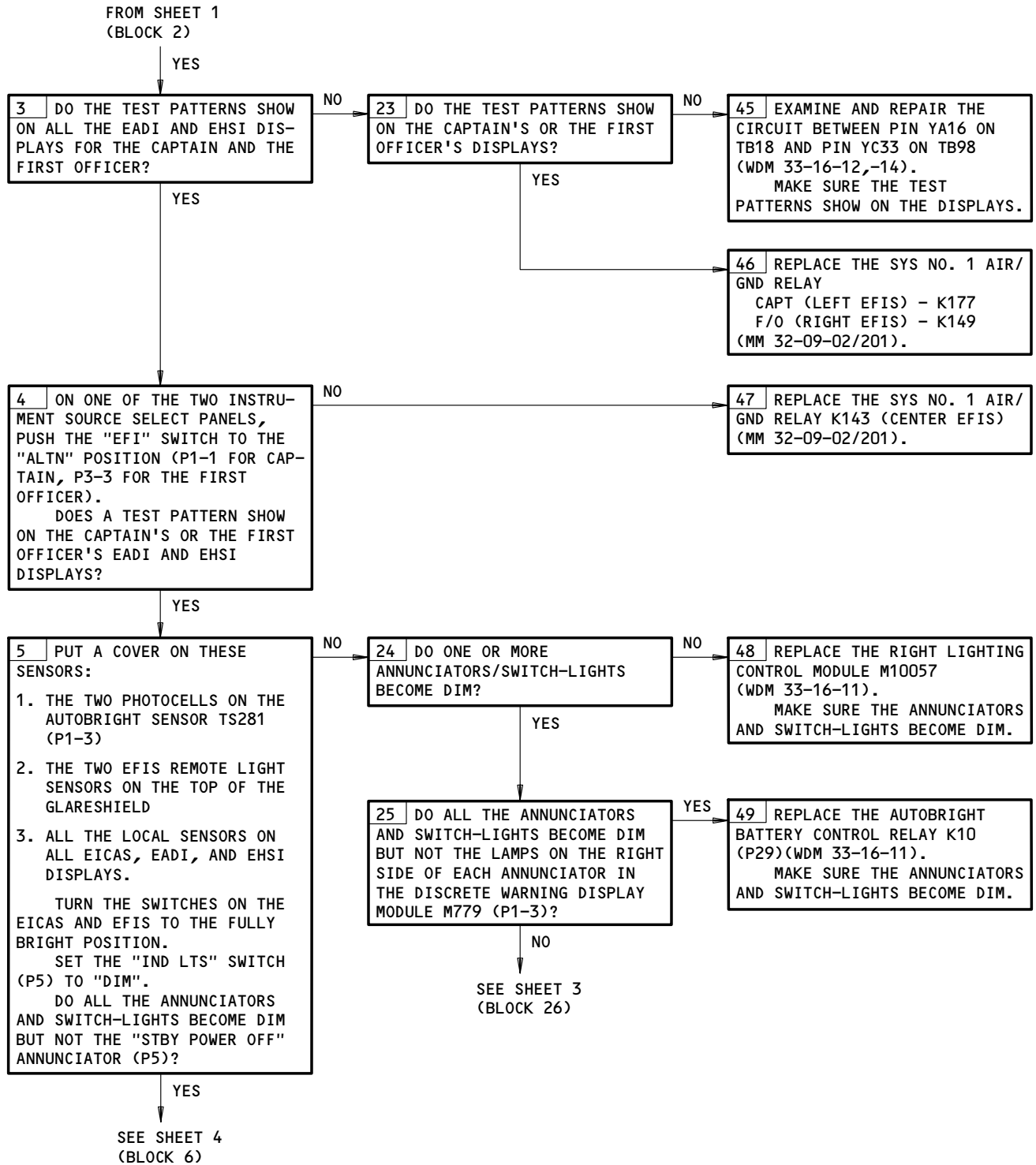

Flight Compartment Master Dim and Test Problems
Figure 103 (Sheet 2)

EFFECTIVITY

ALL

33-16-00

03

Page 105
Feb 10/94

BOEING
767
FAULT ISOLATION/MAINT MANUAL

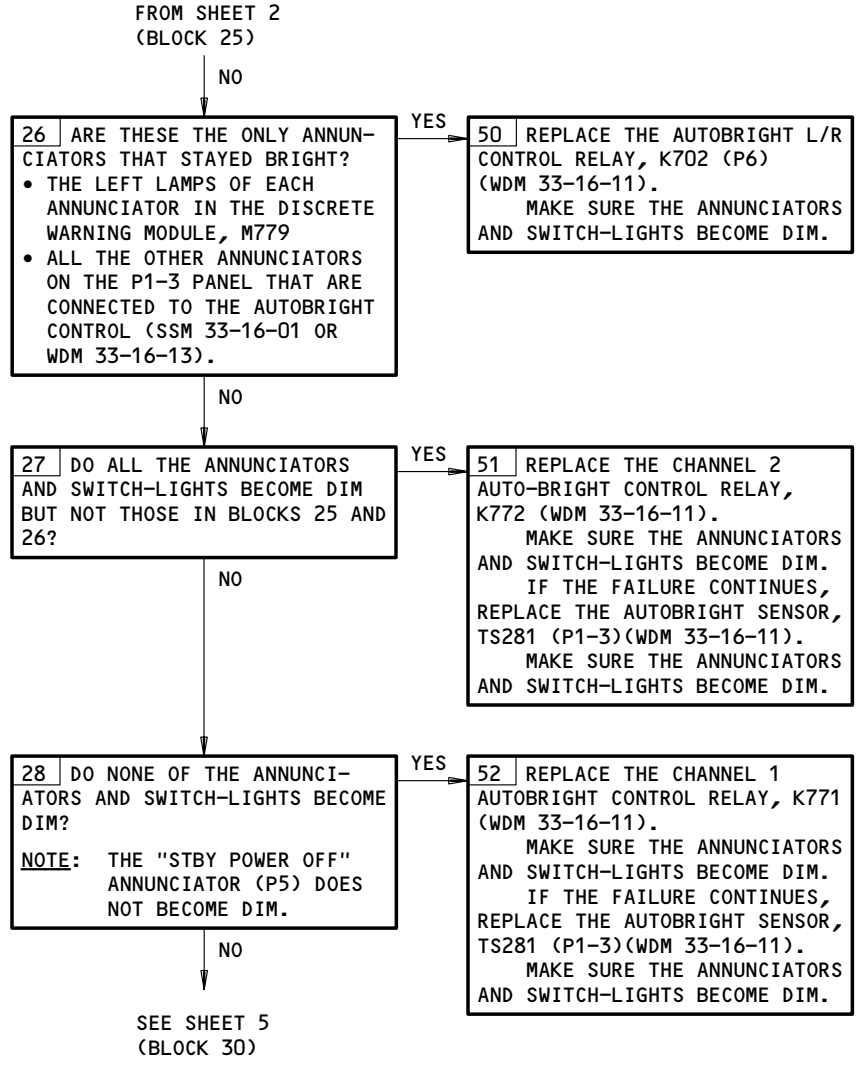

Flight Compartment Master Dim and Test Problems
Figure 103 (Sheet 3)

EFFECTIVITY

ALL

33-16-00

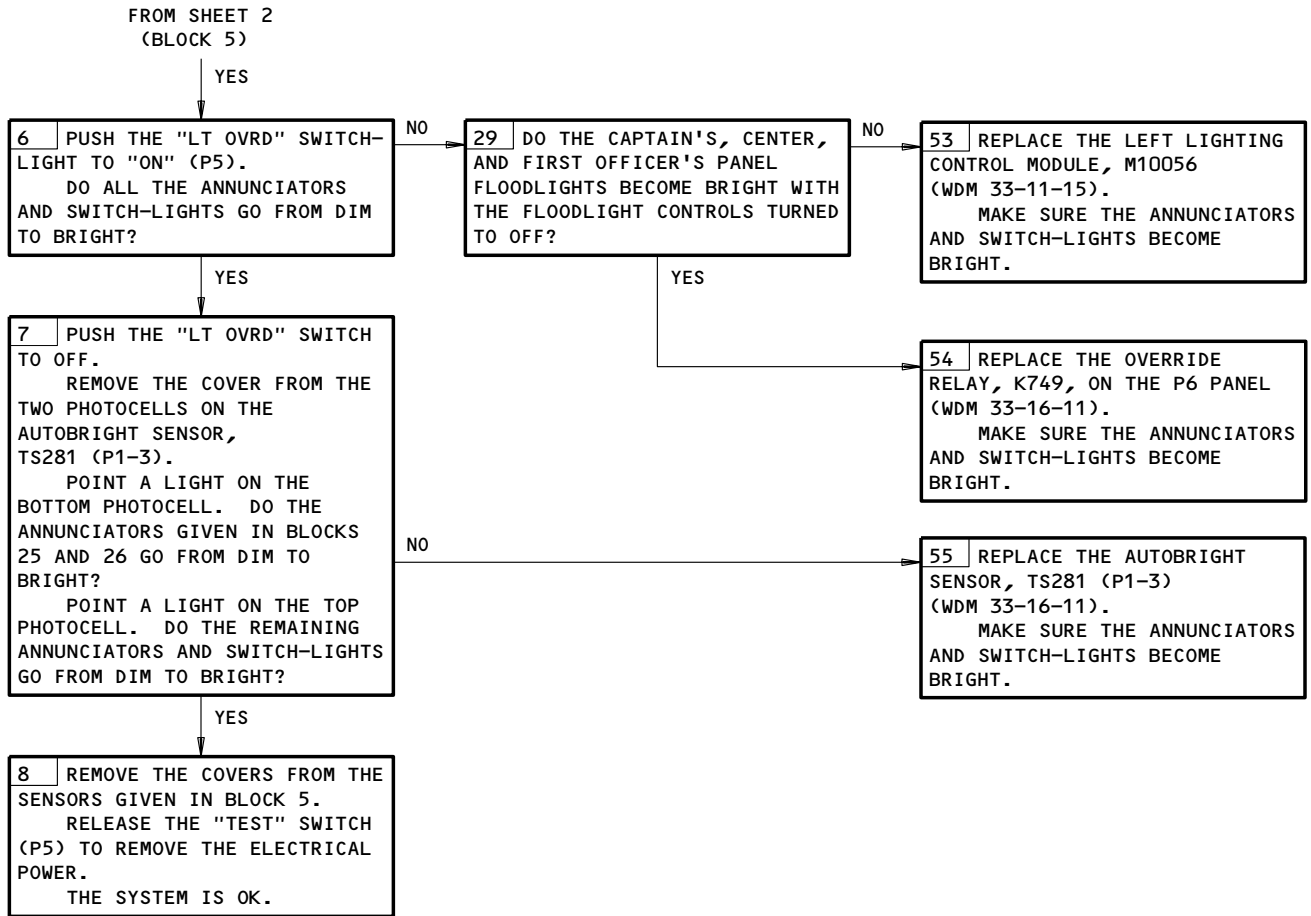

Flight Compartment Master Dim and Test Problems
Figure 103 (Sheet 4)

EFFECTIVITY

ALL

33-16-00

FROM SHEET 3
(BLOCK 28)

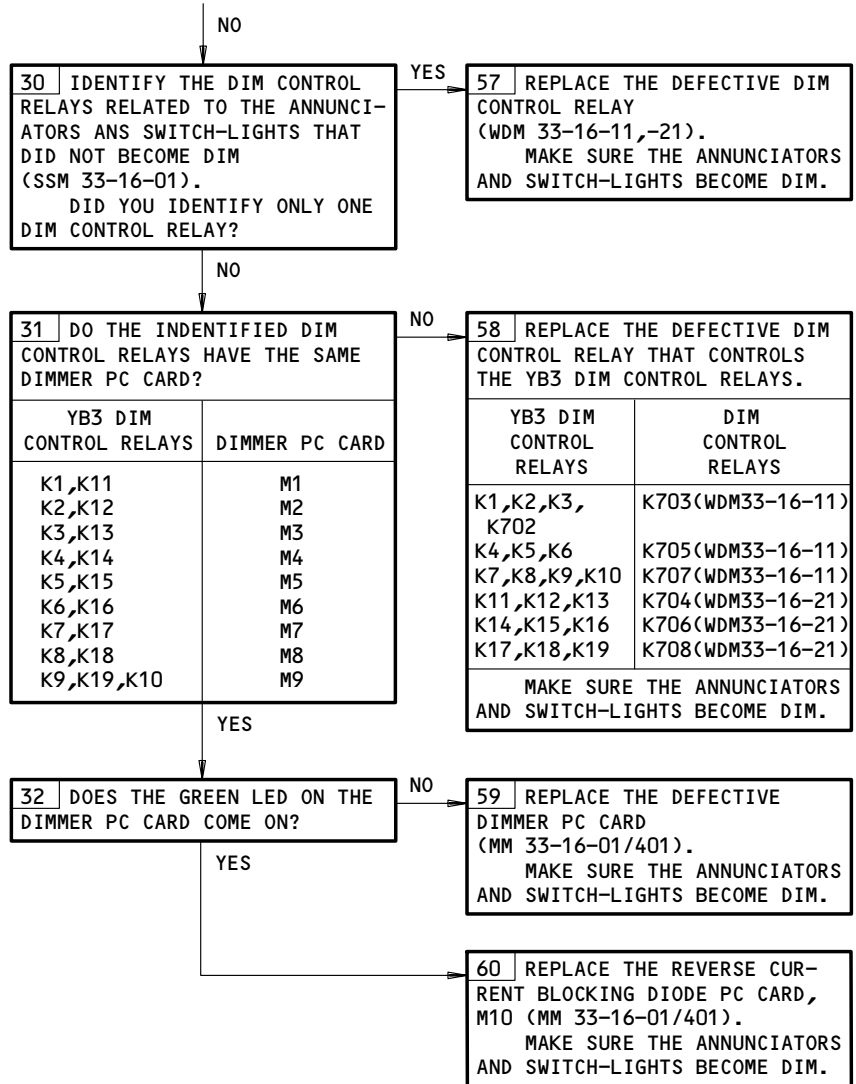

Flight Compartment Master Dim and Test Problems
Figure 103 (Sheet 5)



EFFECTIVITY	ALL
-------------	-----

33-16-00



767
 FAULT ISOLATION/MAINT MANUAL

PASSENGER COMPARTMENT ILLUMINATION

COMPONENT*	FIG. 102 SHT	QTY *	ACCESS/AREA	AMM REFERENCE
BALLAST -	--		PASS. COMPT	33-21-00
CIRCUIT BREAKER -	1		FLT COMPT, P11	*
CIRCUIT BREAKER -	1		119AL, MAIN EQUIP CTR, P36,P37	*
LIGHT -				
INDIRECT CEILING	2		PASS. COMPT	33-21-00
NIGHT	2		PASS. COMPT	33-21-00
PARTITION WASH 	2		PASS. COMPT	33-21-00
SIDEWALL	2		PASS. COMPT	33-21-00
RELAY -	2		PASS. COMPT, P19,P25	
SWITCH -				
LIGHT	2		PASS. COMPT	*
PASS. CABIN ALTITUDE 	--		PASS. COMPT	*
TRANSFORMER -			PASS. COMPT	*

* SEE THE SSM OR WDM FOR THE EQUIPMENT NUMBER, QUANTITY, AND LOCATION OF EACH COMPONENT IN THE LIGHTING CIRCUIT.

 NOT INSTALLED ON ALL AIRPLANES

Passenger Compartment Illumination - Component Index
 Figure 101

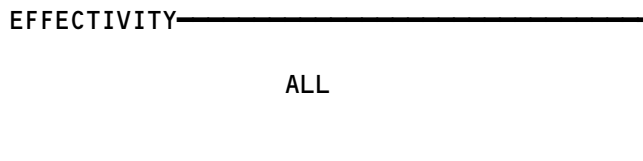

33-21-00

01

Page 101
 Nov 10/95

998639

BOEING
767
FAULT ISOLATION/MAINT MANUAL

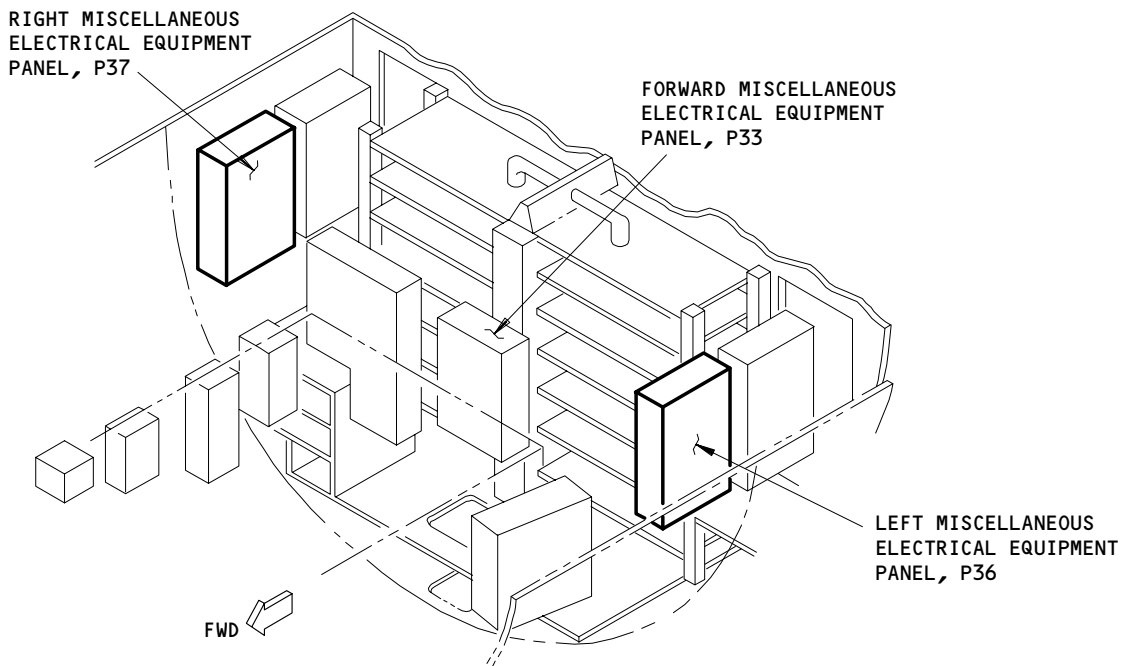
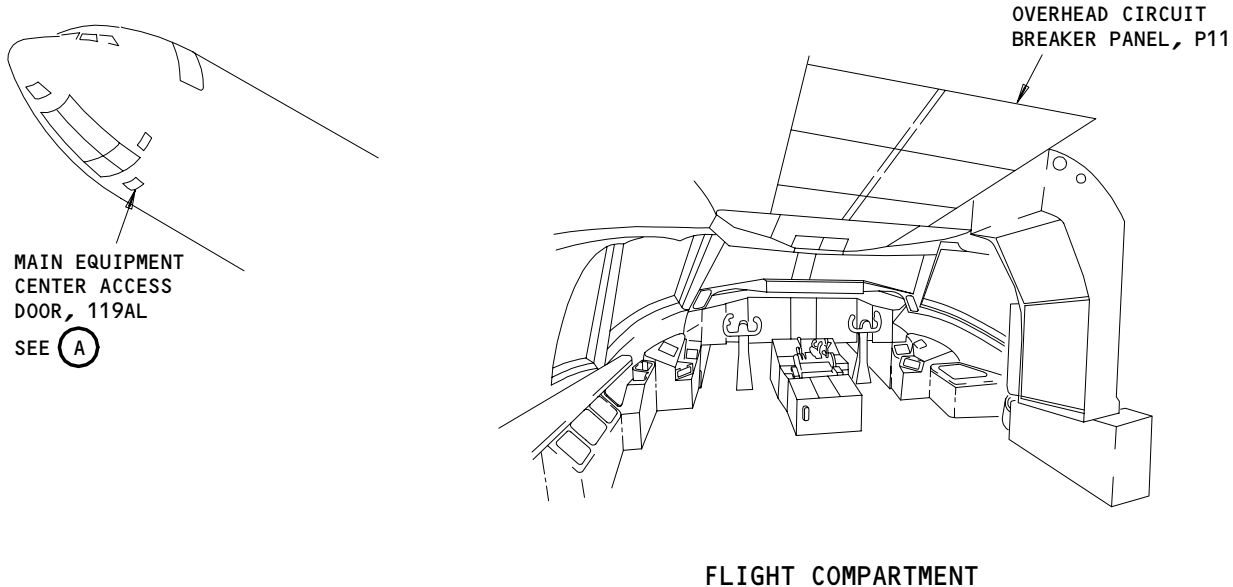

(A)

Passenger Compartment Illumination Lights - Component Location
Figure 102 (Sheet 1)

EFFECTIVITY	
	ALL

33-21-00

01

Page 102
Nov 10/94

BOEING
767
FAULT ISOLATION/MAINT MANUAL

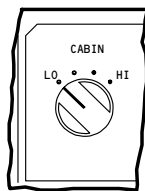
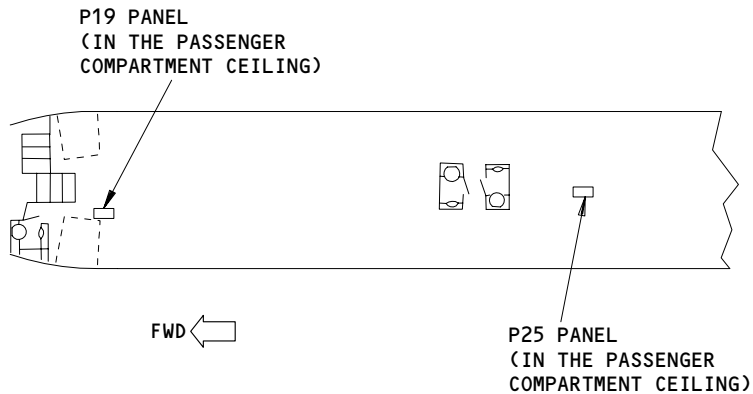
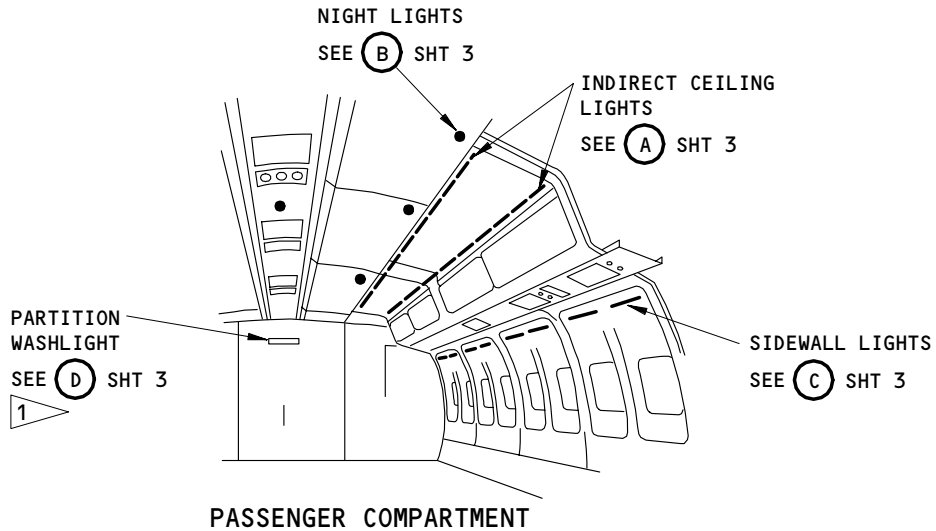

ATTENDANT LIGHTS
CONTROL SWITCH
(INSTALLED ON
ATTENDANT'S PANEL)

1 NOT INSTALLED ON ALL AIRPLANES

Passenger Compartment Illumination Lights - Component Location
Figure 102 (Sheet 2)

EFFECTIVITY	
	ALL

33-21-00

01

Page 103
Nov 10/94

953413

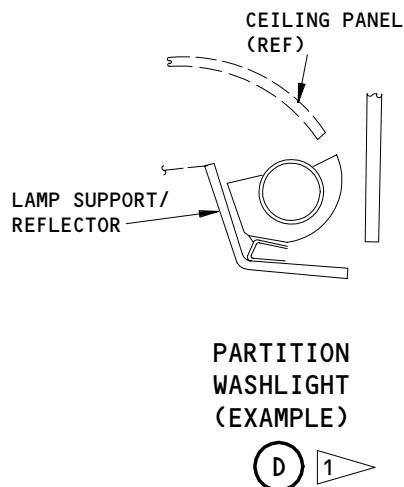
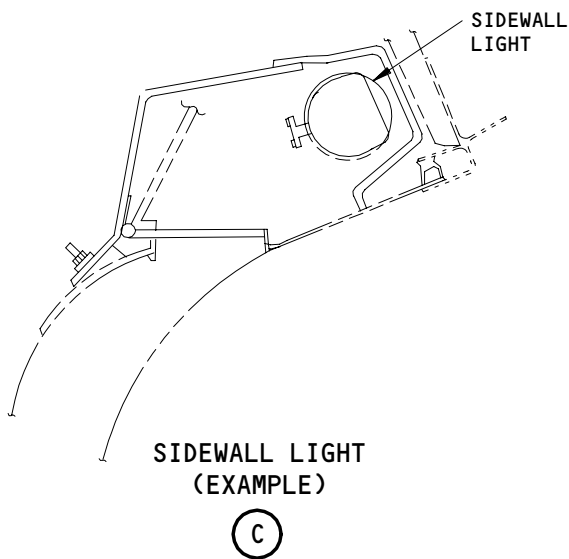
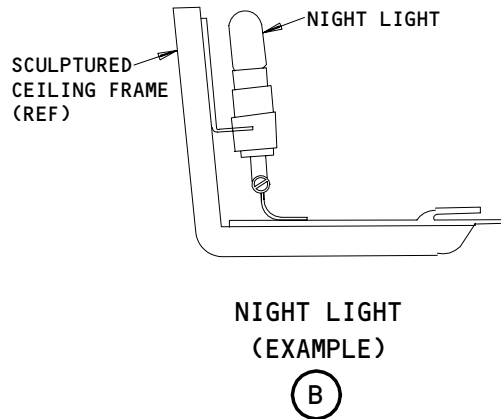
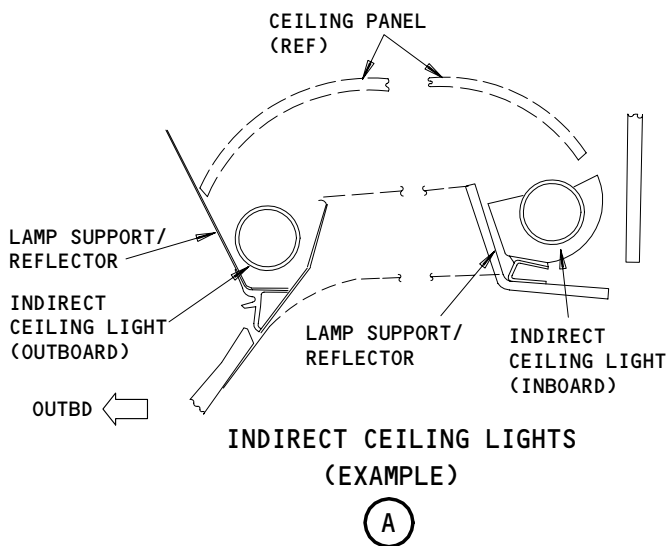

1 NOT INSTALLED ON ALL AIRPLANES

Passenger Compartment Illumination Lights - Component Location
Figure 102 (Sheet 3)

EFFECTIVITY	ALL
-------------	-----

33-21-00

Not Used
Figure 103

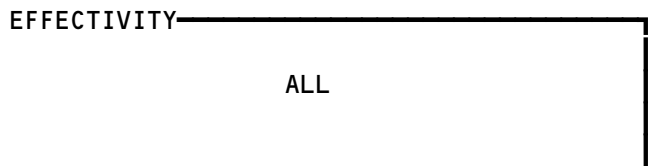

33-21-00

01

Page 105
Nov 10/94

D16443

PREREQUISITES
MAKE SURE THE APPLICABLE CIRCUIT BREAKERS ARE CLOSED:
(SSM 33-21-01; WDM 33-21-11)
MAKE SURE THE AIRPLANE IS IN THIS CONFIGURATION:
ELECTRICAL POWER IS ON (AMM 24-22-00/201)

INDIRECT CEILING LIGHTS PROBLEMS

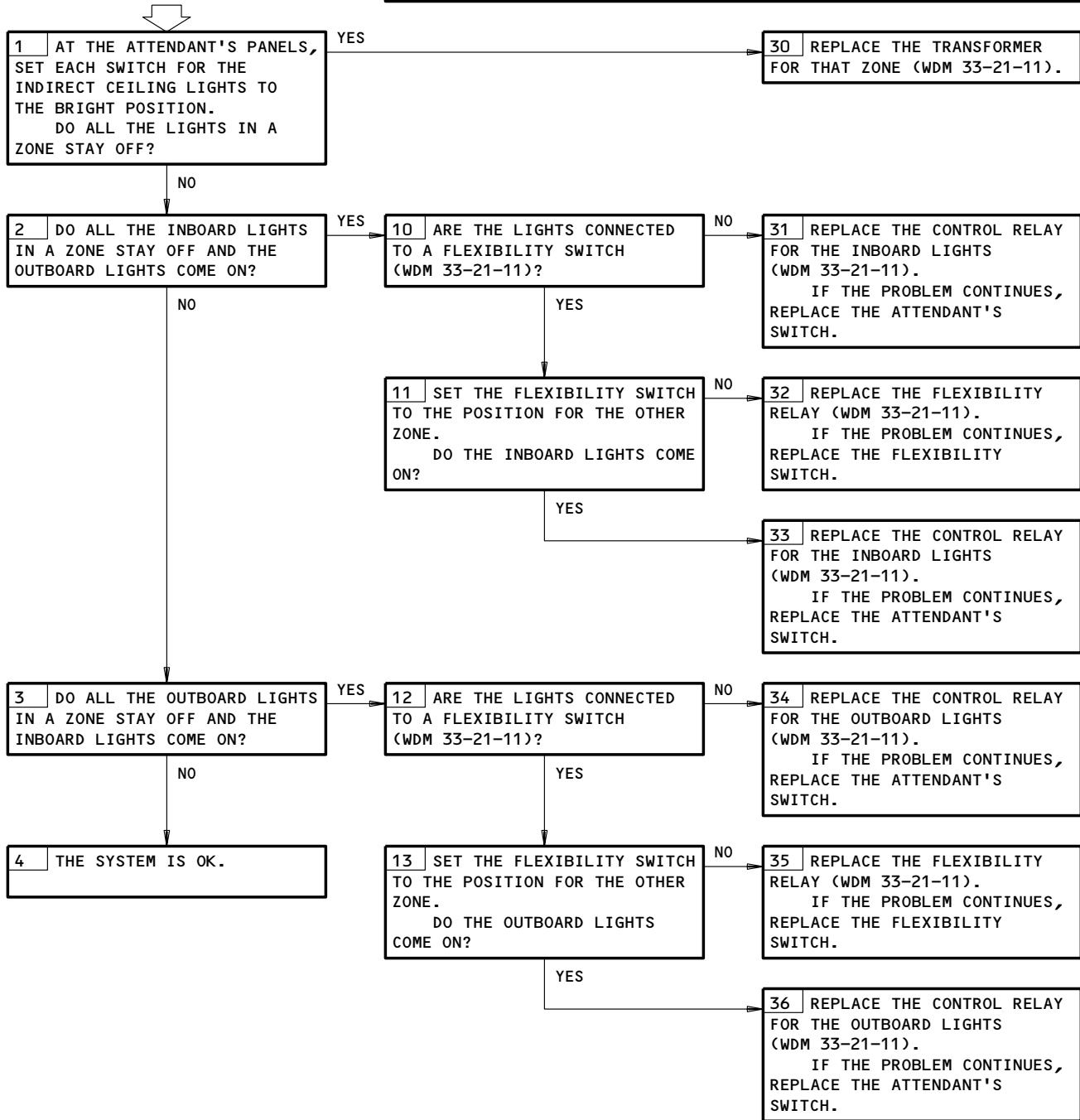

Indirect Ceiling Lights Problems
Figure 104

EFFECTIVITY

ALL

33-21-00

01

Page 106
Apr 22/99

770550

PREREQUISITES
 MAKE SURE THE APPLICABLE CIRCUIT BREAKERS ARE CLOSED:
 (SSM 33-21-02; WDM 33-21-21)
 MAKE SURE THE AIRPLANE IS IN THIS CONFIGURATION:
 ELECTRICAL POWER IS ON (AMM 24-22-00/201)

NIGHT LIGHTS PROBLEMS

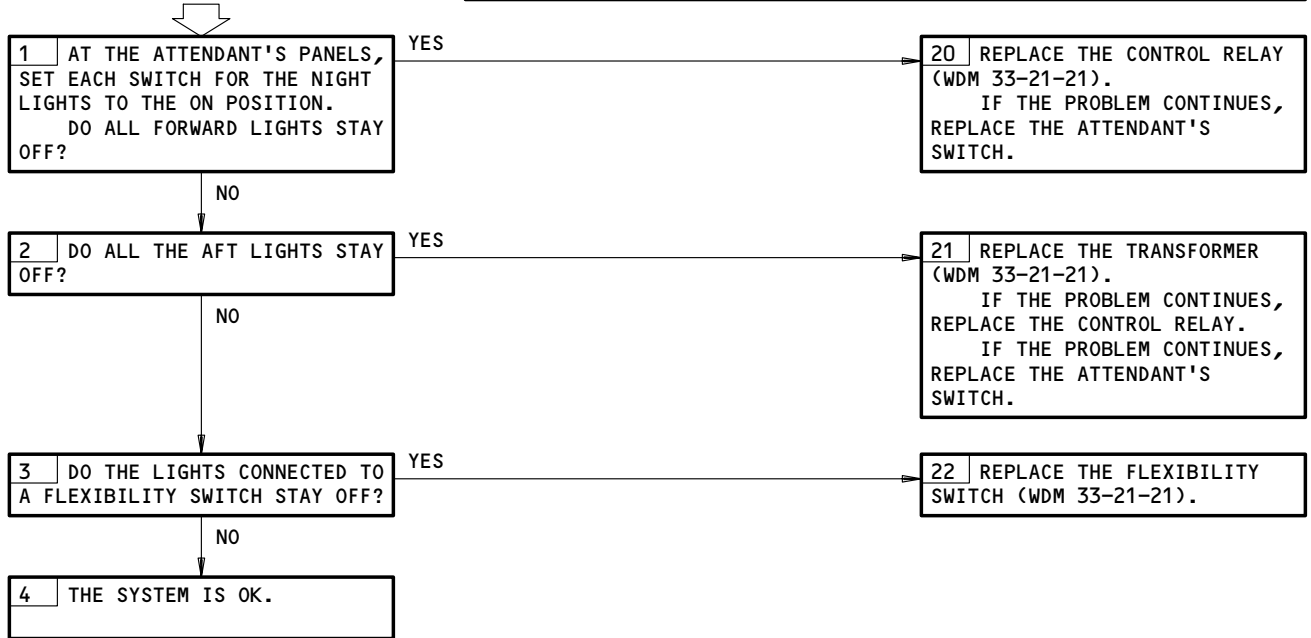

Night Lights Problems
Figure 105

EFFECTIVITY ————
 ALL

33-21-00

674627

SIDEWALL WASHLIGHTS PROBLEMS

PREREQUISITES
 MAKE SURE THE APPLICABLE CIRCUIT BREAKERS ARE CLOSED:
 (SSM 33-21-03; WDM 33-21-31)
 MAKE SURE THE AIRPLANE IS IN THIS CONFIGURATION:
 ELECTRICAL POWER IS ON (AMM 24-22-00/201)

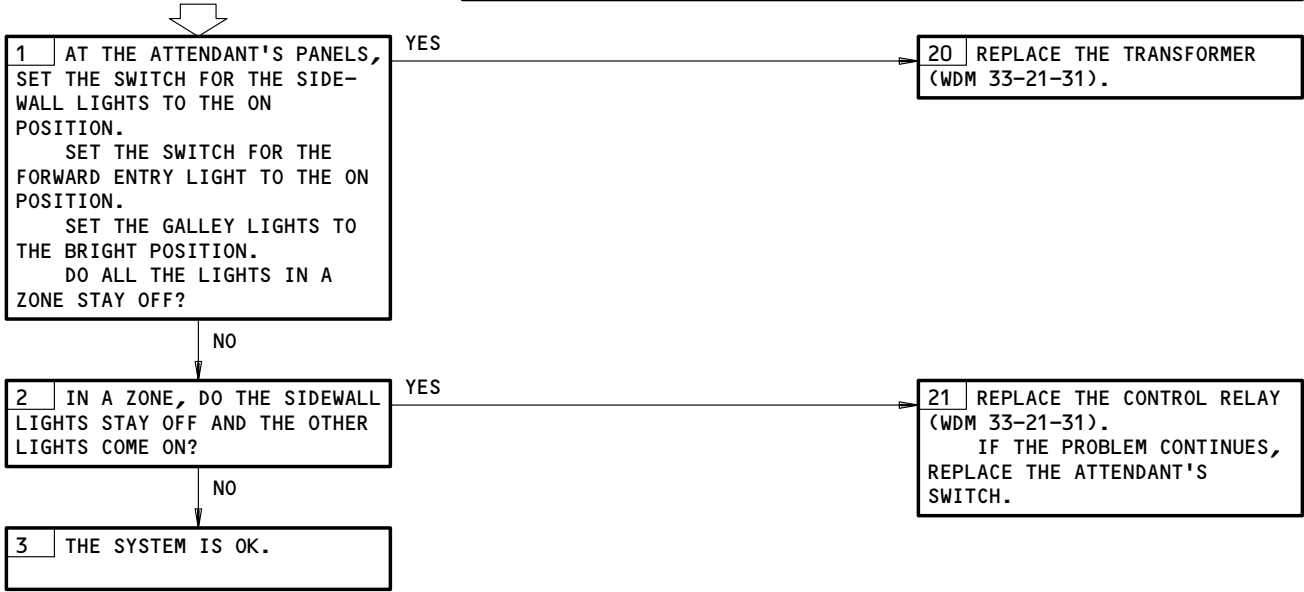

Sidewall Washlights Problems
Figure 106

EFFECTIVITY	ALL
-------------	-----

33-21-00

**PARTITION
WASHLIGHTS PROBLEMS**

PREREQUISITES

MAKE SURE EACH APPLICABLE CIRCUIT BREAKER IS CLOSED
(SSM 33-21-01 THRU 33-21-03 OR WDM 33-21-11 THRU
33-21-36)

MAKE SURE THE AIRPLANE IS IN THIS CONFIGURATION:
ELECTRICAL POWER IS ON (AMM 24-22-00/201)

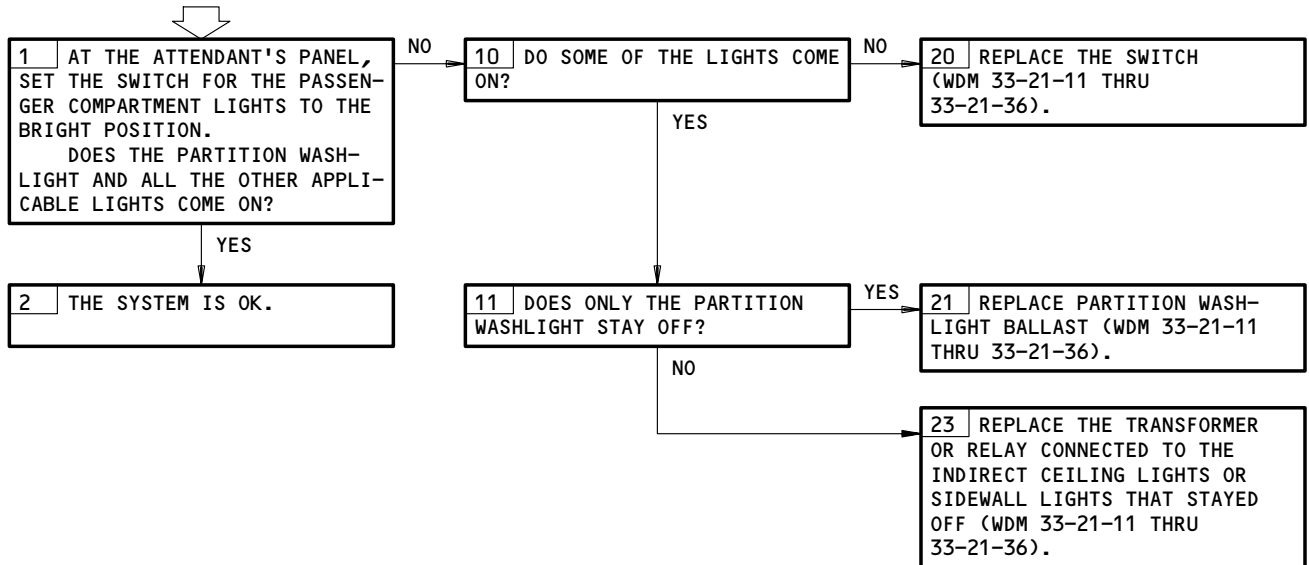



Partition Washlights Problems
Figure 107

EFFECTIVITY
AIRPLANES WITH PARTITION WASHLIGHTS

33-21-00

BOEING
767
FAULT ISOLATION/MAINT MANUAL

PASSENGER LOADING LIGHTS

COMPONENT	FIG. 102 SHT	QTY	ACCESS/AREA	AMM REFERENCE
BALLAST -	--		PASS. COMPT, ADJACENT TO LIGHT	33-22-00
CIRCUIT BREAKER -	1		119AL, MAIN EQUIP CTR, P33	33-22-00
LIGHT -				
ATTENDANT WORK	2		PASS. COMPT	33-22-00
CLOSET	--		PASS. COMPT	33-22-00
DIRECT CEILING	--		PASS. COMPT	33-22-00
ENTRY	2		PASS. COMPT	33-22-00
PANEL -				
AFT ATTENDANT'S	--		PASS. COMPT	33-22-06
FWD ATTENDANT'S	--		PASS. COMPT	33-22-05
RELAY -	--		PASS. COMPT, P19,P25	*
SWITCH -				
ALTITUDE PRESSURE 	--		PASS. COMPT, P19	*
DOOR	--		FLT COMPT DOOR	*
LIGHT	2		PASS. COMPT	*
PROX ELEC UNIT 	1		119AL, MAIN EQUIP CTR, E1-SHELF	*
TRANSFORMER -	1		119AL, MAIN EQUIP CTR	*

* SEE THE SSM OR WDM FOR THE EQUIPMENT NUMBER, QUANTITY, AND LOCATION OF EACH COMPONENT IN THE LIGHTING CIRCUIT.

 NOT INSTALLED ON ALL AIRPLANES

Passenger Loading Lights - Component Index
Figure 101

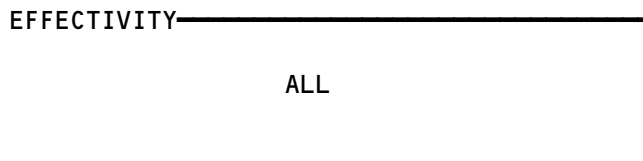

33-22-00

01

Page 101
Nov 10/95

201749

BOEING
767
FAULT ISOLATION/MAINT MANUAL

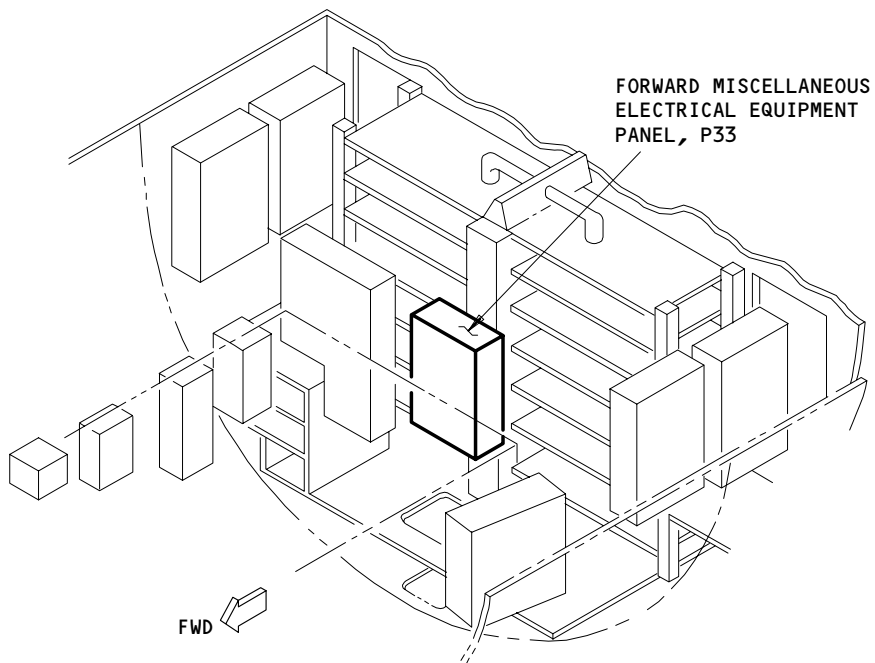
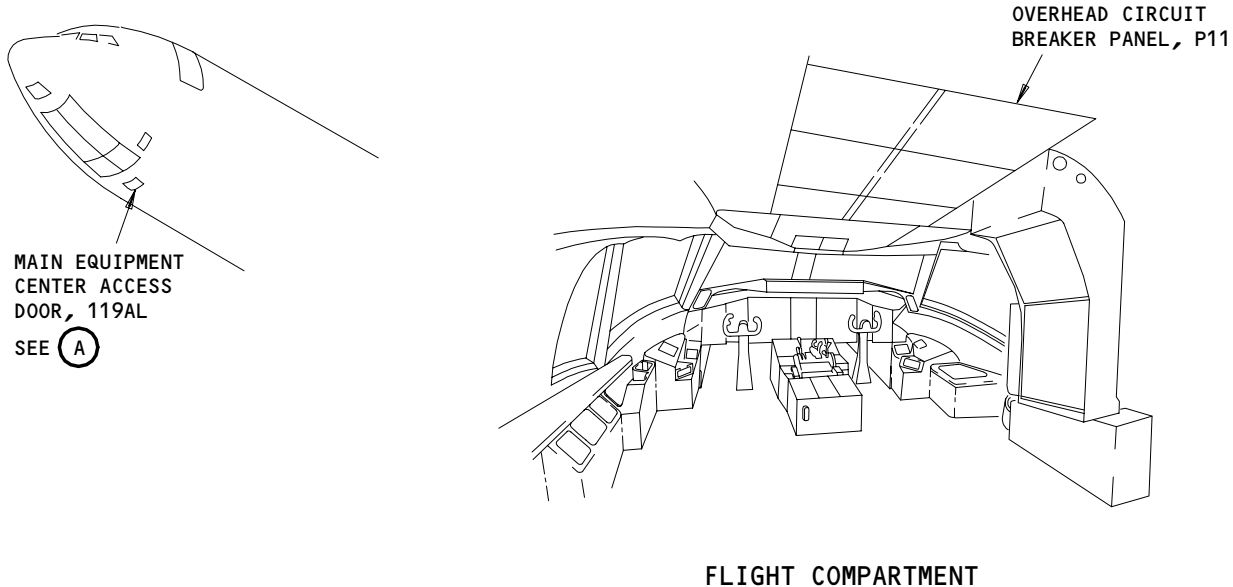

Passenger Loading Lights - Component Location
Figure 102 (Sheet 1)

EFFECTIVITY	
	ALL

33-22-00

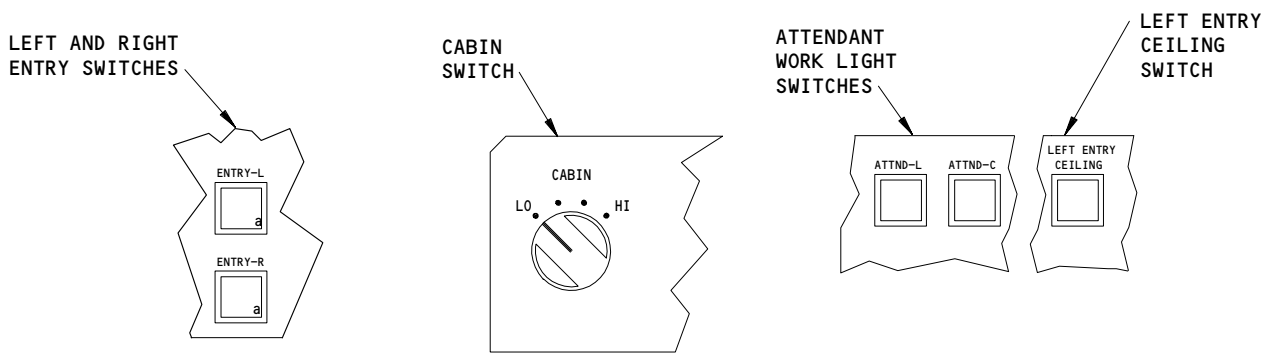

**ATTENDANT'S PANEL LIGHTS
 CONTROL SWITCHES
 (EXAMPLE)**

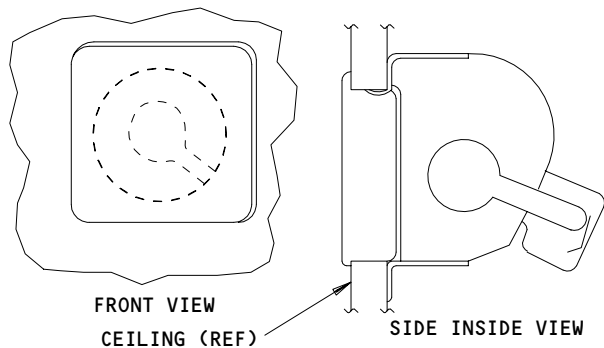

**ATTENDANT'S WORK LIGHTS/ENTRY LIGHTS
 (EXAMPLE)**

**Passenger Loading Lights - Component Location
 Figure 102 (Sheet 2)**

EFFECTIVITY	ALL
-------------	-----

33-22-00

950150

THRESHOLD ENTRY LIGHTS PROBLEMS

PREREQUISITES
MAKE SURE THESE CIRCUIT BREAKERS ARE CLOSED:
11U28, 33K4, 33K5
MAKE SURE THE AIRPLANE IS IN THIS CONFIGURATION:
ELECTRICAL POWER IS ON (AMM 24-22-00/201)

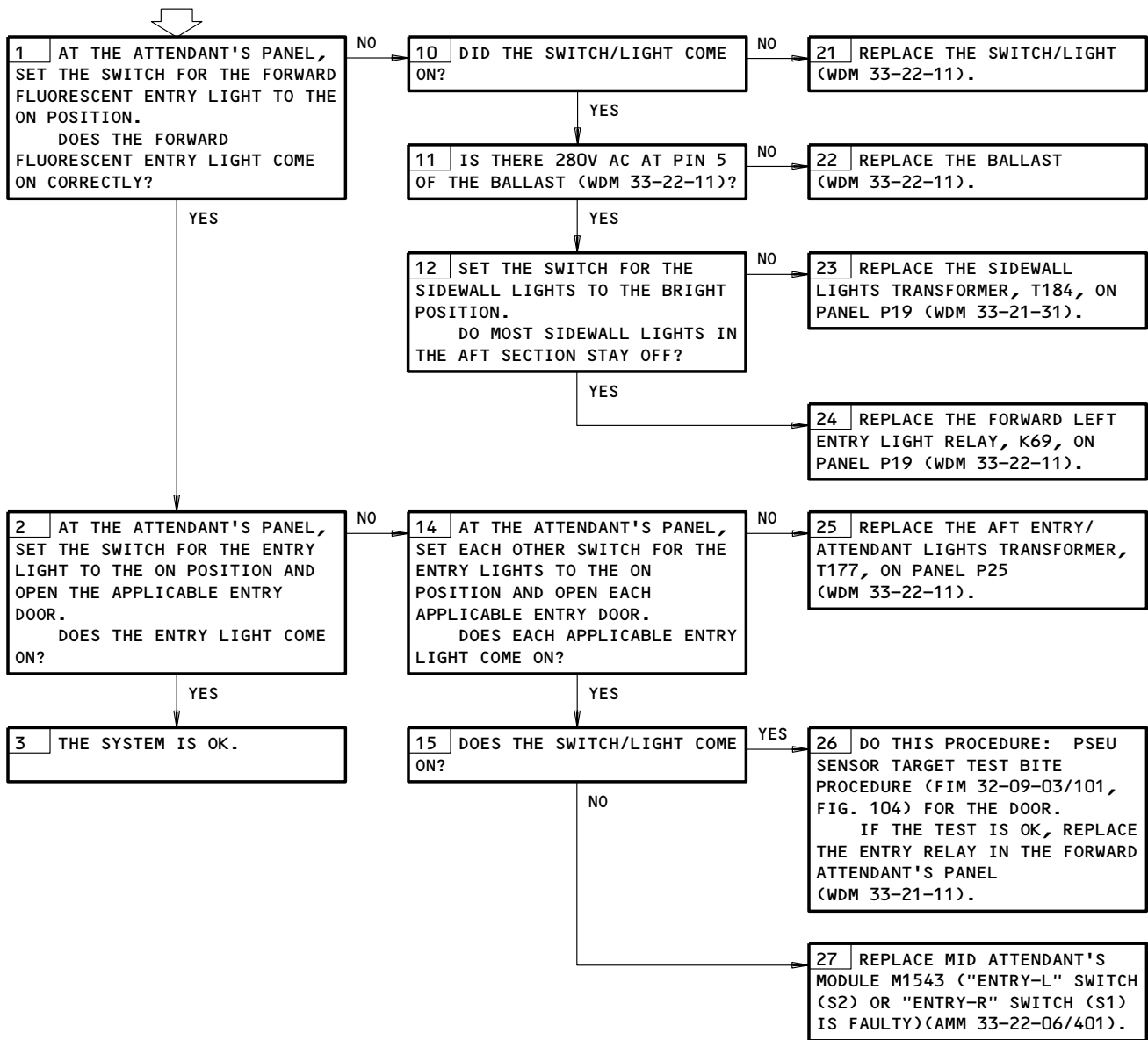

Threshold Entry Lights Problems
Figure 103

EFFECTIVITY ————
ALL

33-22-00

ATTENDANT'S WORK LIGHTS PROBLEMS

PREREQUISITES
 MAKE SURE THESE CIRCUIT BREAKERS ARE CLOSED:
 33K4, 33K5
 MAKE SURE THE AIRPLANE IS IN THIS CONFIGURATION:
 ELECTRICAL POWER IS ON (AMM 24-22-00/201)

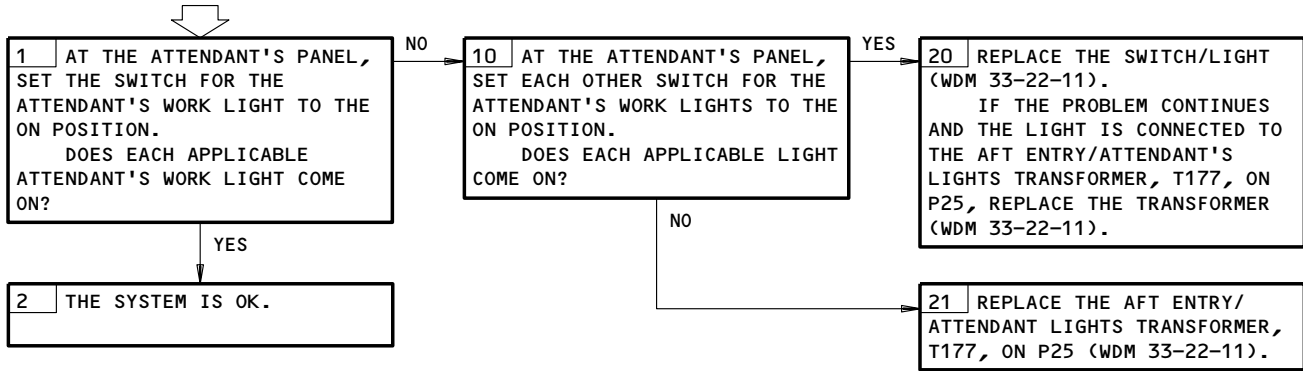

Attendant's Work Lights Problems
Figure 104

EFFECTIVITY

ALL

33-22-00

AFT DIRECT CEILING LIGHTS PROBLEMS WITH "CABIN" SWITCH ON P22 IN "LO"

PREREQUISITES
MAKE SURE EACH APPLICABLE CIRCUIT BREAKER IS CLOSED:
(SSM 33-22-02 OR WDM 33-22-42)
MAKE SURE THE AIRPLANE IS IN THIS CONFIGURATION:
ELECTRICAL POWER IS ON (AMM 24-22-00/201)

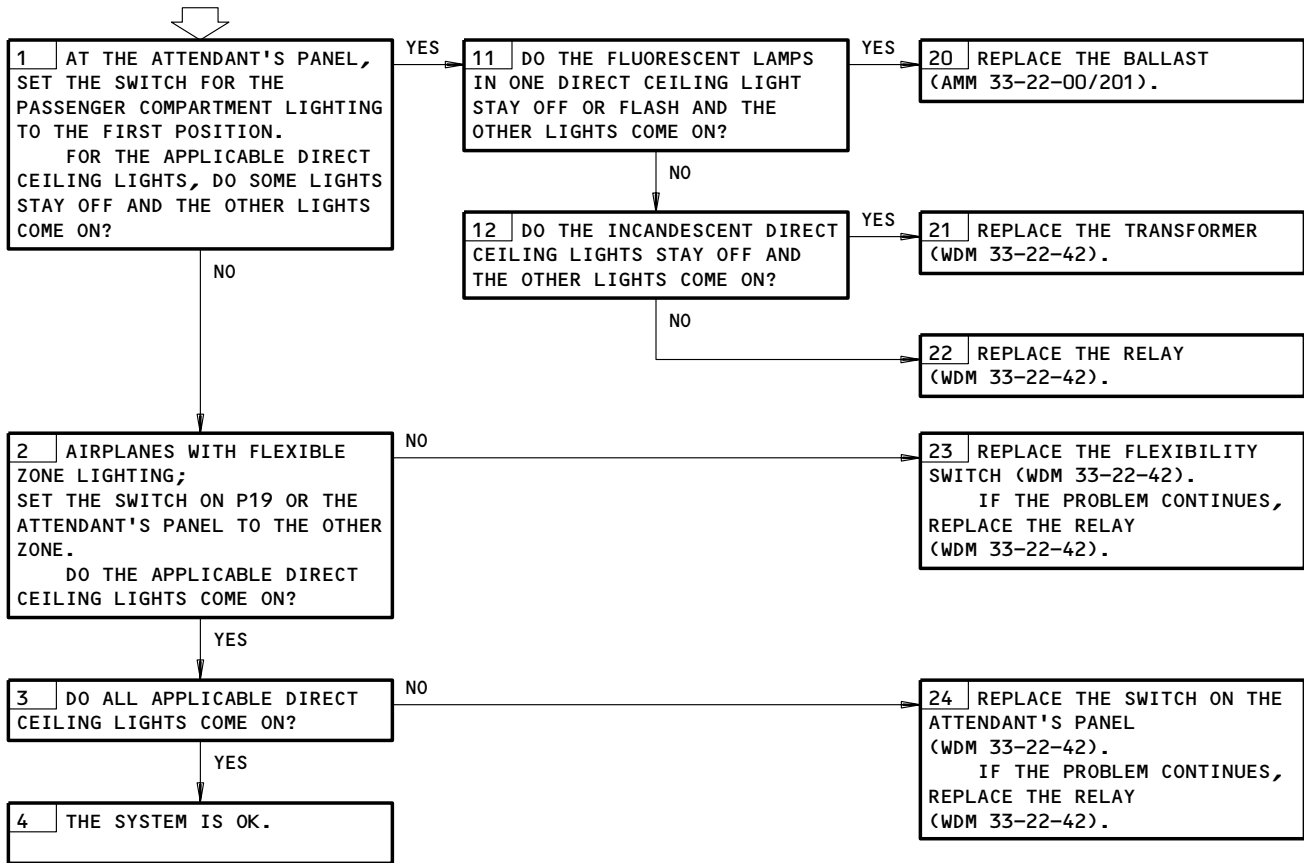

Aft Direct Ceiling Lights Problems with CABIN Switch in LO
Figure 105

EFFECTIVITY	ALL
-------------	-----

33-22-00

AFT DIRECT CEILING LIGHTS PROBLEMS WITH "CABIN" SWITCH ON P22 IN THE SECOND POSITION

PREREQUISITES
MAKE SURE EACH APPLICABLE CIRCUIT BREAKER IS CLOSED:
(SSM 33-22-02 OR WDM 33-22-42)
MAKE SURE THE AIRPLANE IS IN THIS CONFIGURATION:
ELECTRICAL POWER IS ON (AMM 24-22-00/201)

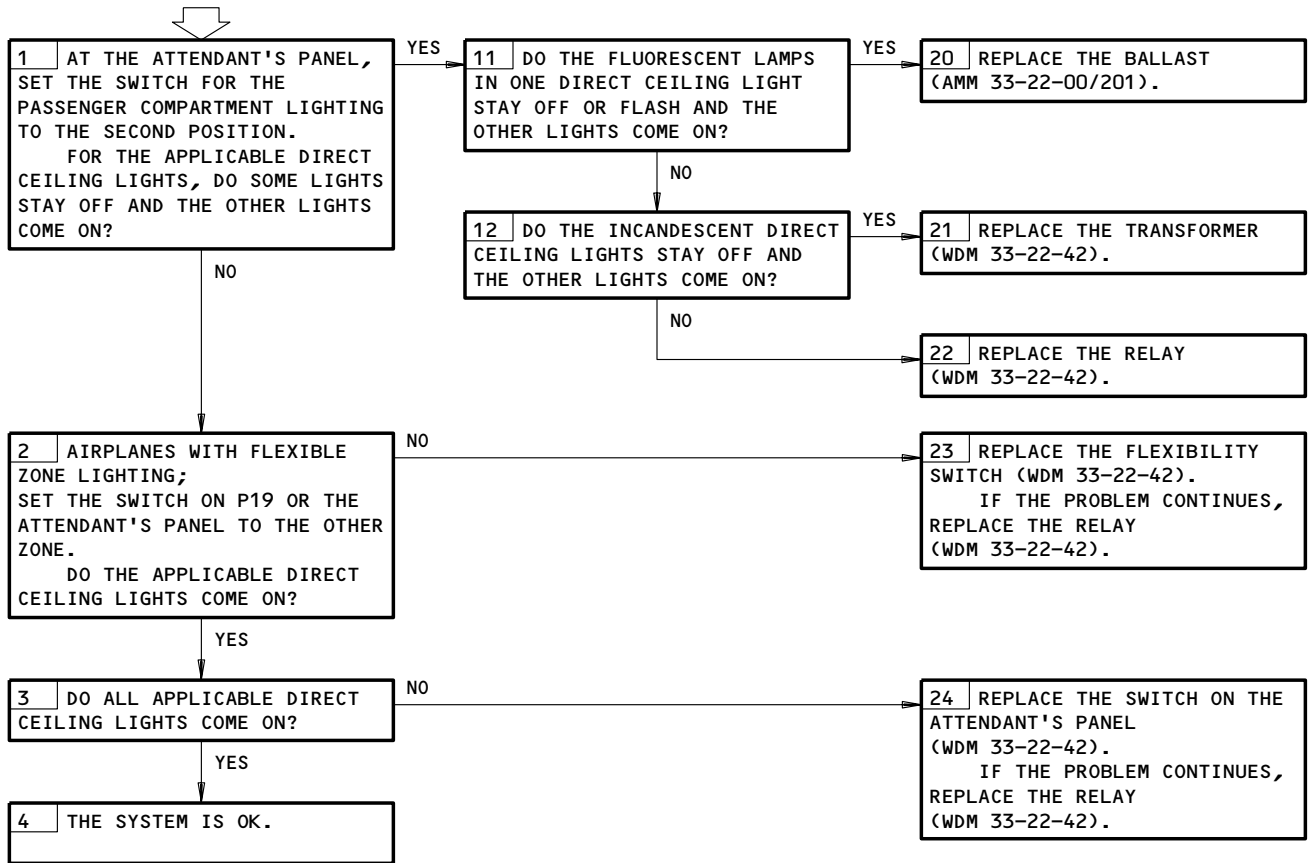

Aft Direct Ceiling Lights Problems with CABIN Switch on P22 in the Second Position
Figure 106

EFFECTIVITY

ALL

33-22-00

AFT DIRECT CEILING LIGHTS PROBLEMS WITH "CABIN" SWITCH ON P22 IN THIRD POSITION

PREREQUISITES
 MAKE SURE EACH APPLICABLE CIRCUIT BREAKER IS CLOSED:
 (SSM 33-22-02 OR WDM 33-22-42)
 MAKE SURE THE AIRPLANE IS IN THIS CONFIGURATION:
 ELECTRICAL POWER IS ON (AMM 24-22-00/201)

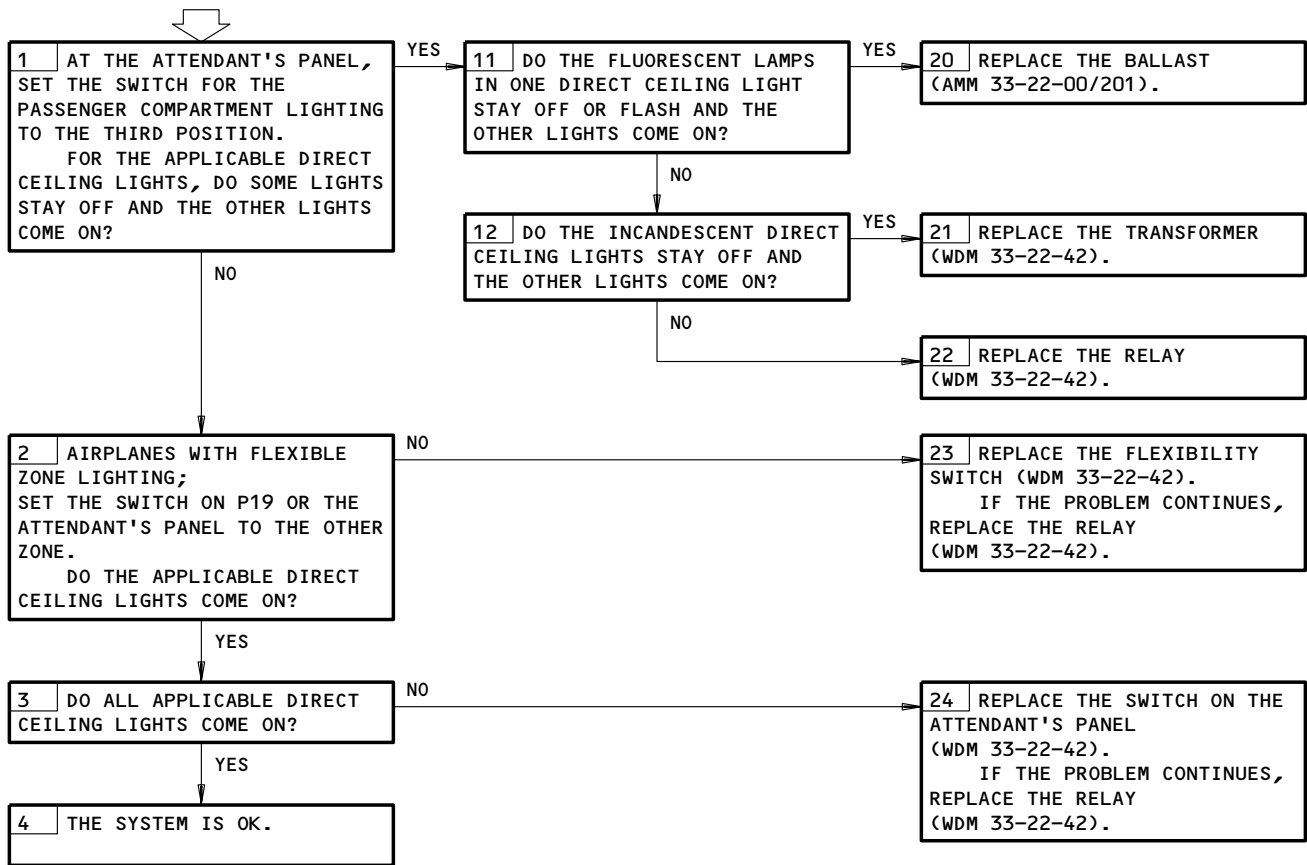

Aft Direct Ceiling Lights Problems with CABIN Switch in Third Position
Figure 107

EFFECTIVITY	ALL
-------------	-----

33-22-00

AFT DIRECT CEILING LIGHTS PROBLEMS WITH "CABIN" SWITCH ON PANEL P22 IN "HI"

PREREQUISITES
MAKE SURE EACH APPLICABLE CIRCUIT BREAKER IS CLOSED:
(SSM 33-22-02 OR WDM 33-22-42)
MAKE SURE THE AIRPLANE IS IN THIS CONFIGURATION:
ELECTRICAL POWER IS ON (AMM 24-22-00/201)

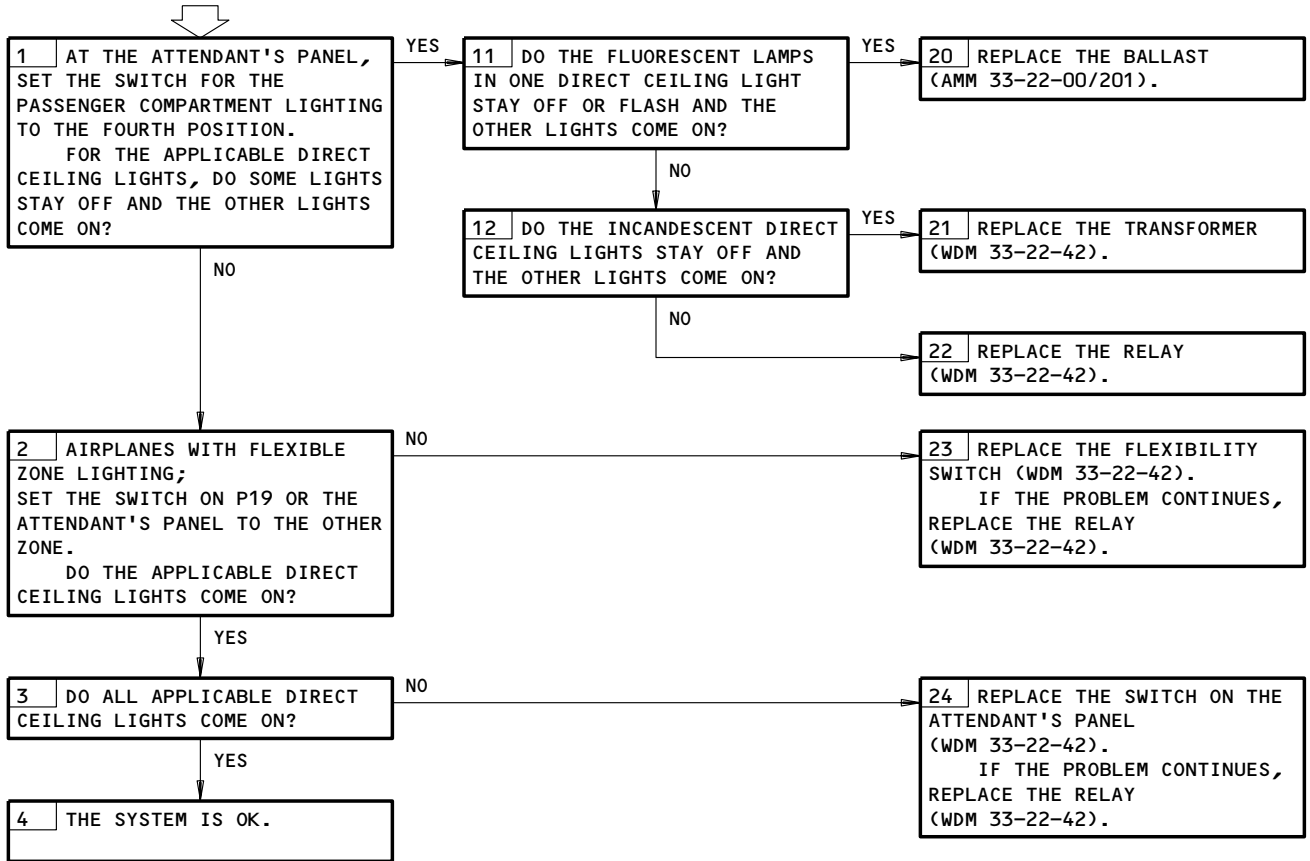

Aft Direct Ceiling Lights Problems with CABIN Switch in HI
Figure 108

EFFECTIVITY

ALL

33-22-00

**FORWARD DIRECT
CEILING LIGHTS
PROBLEMS**

PREREQUISITES
 MAKE SURE EACH APPLICABLE CIRCUIT BREAKER IS CLOSED:
 (SSM 33-22-02 OR WDM 33-22-41)
 MAKE SURE THE AIRPLANE IS IN THIS CONFIGURATION:
 ELECTRICAL POWER IS ON (AMM 24-22-00/201)
 FLIGHT COMPARTMENT DOOR IS CLOSED

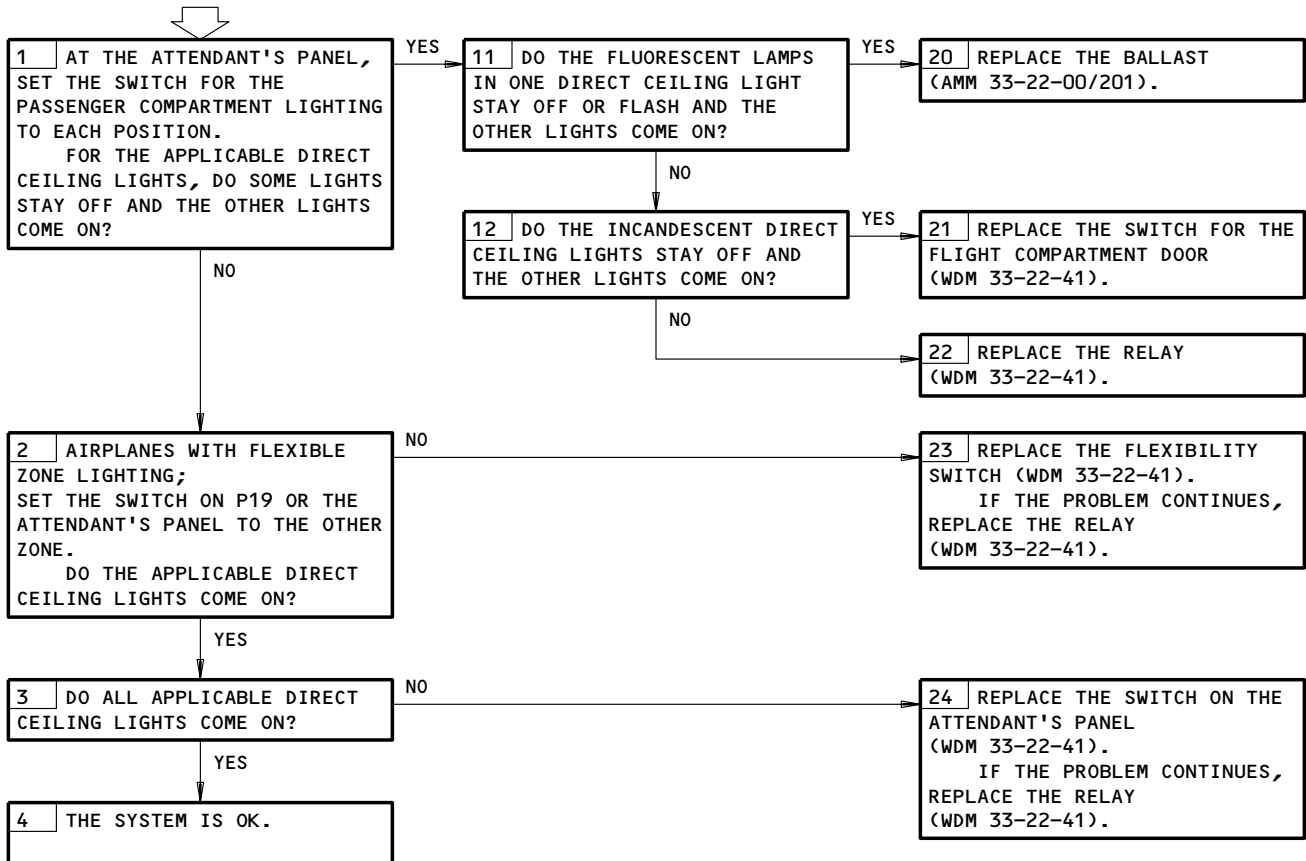

Forward Direct Ceiling Lights Problems
Figure 109

EFFECTIVITY	ALL
-------------	-----

33-22-00

BOEING
767
FAULT ISOLATION/MAINT MANUAL

PASSENGER SIGNS

COMPONENT*	FIG. 102 SHT	QTY *	ACCESS/AREA	AMM REFERENCE
CIRCUIT BREAKER -			FLT COMPT, P11	*
CIRCUIT BREAKER -			119AL, MAIN EQUIP CTR, P33	*
LIGHT -				
NO SMOKING FASTEN SEAT BELT			EACH PASS. SERVICE UNIT	33-24-00
RETURN TO SEAT			EACH LAVATORY	33-24-00
RELAY -			PASS. COMPT, P19	*
SWITCH -				
ELEX UNIT PROXIMITY			119AL, MAIN EQUIP CTR, E1-2	*
LIGHT			FLT COMPT, P5	*
FLAPS/SLATS ELEC UNIT			119AL, MAIN EQUIP CTR, E2-4	*
PRESSURE			PASS. COMPT, P19	*

* SEE THE SSM OR WDM FOR THE EQUIPMENT NUMBER, QUANTITY, AND LOCATION OF EACH COMPONENT IN THE LIGHTING CIRCUIT.

Passenger Signs - Component Index
Figure 101

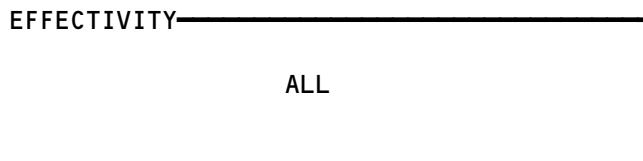

33-24-00

01

Page 101
Feb 10/94

D18886

BOEING

767 FAULT ISOLATION/MAINT MANUAL

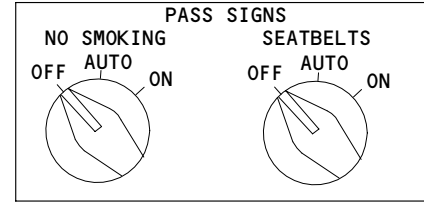
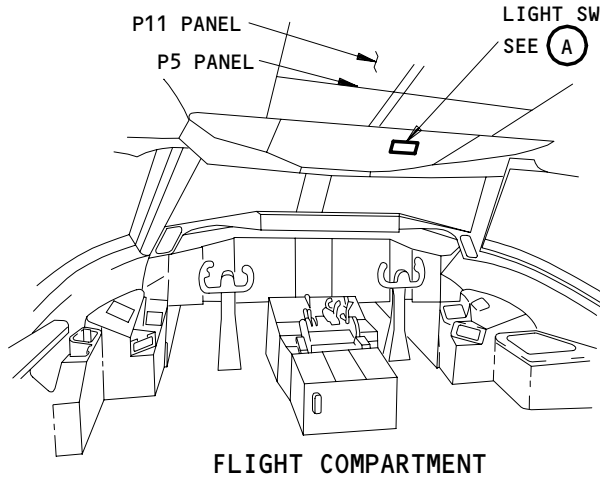

LIGHT SWITCHES

(A)

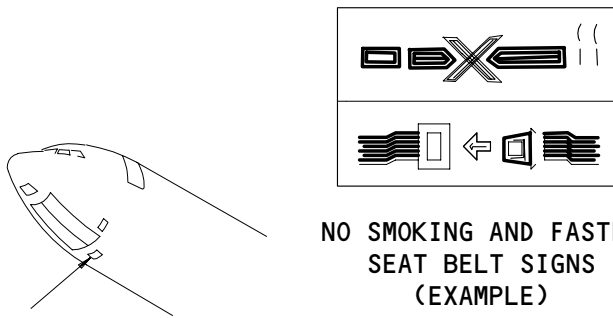

RETURN TO SEAT SIGN (EXAMPLE)

MAIN EQUIPMENT CENTER ACCESS DOOR, 119AL
SEE (B)

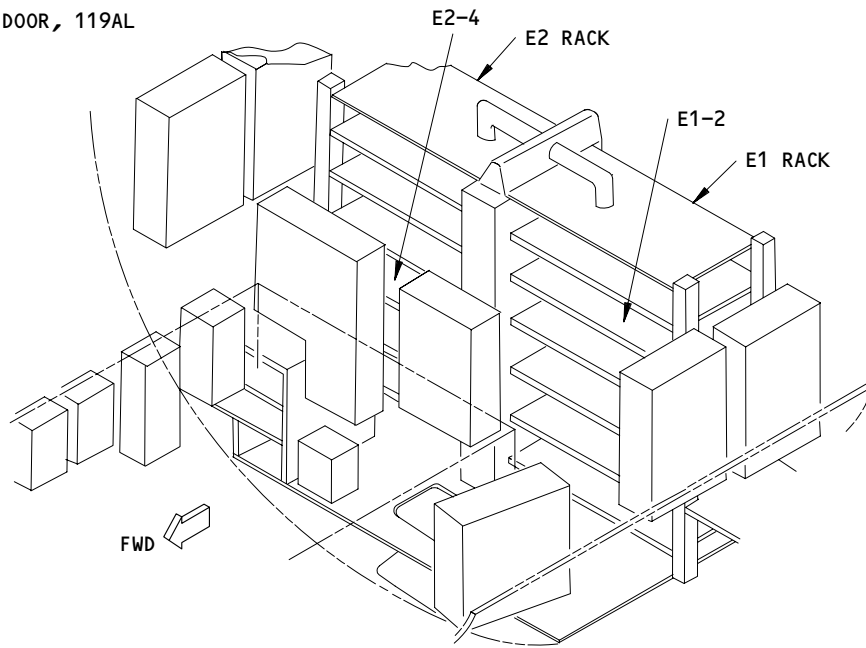

MAIN EQUIPMENT CENTER

(B)

Passenger Signs - Component Location
Figure 102

EFFECTIVITY	ALL
-------------	-----

33-24-00

Not Used
Figure 103

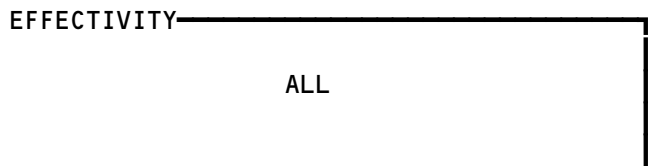

33-24-00

01

Page 103
Feb 10/94

191775

NO SMOKING LIGHTS PROBLEMS

PREREQUISITES

MAKE SURE EACH APPLICABLE CIRCUIT BREAKER IS CLOSED:
(SSM 33-24-01 OR WDM 33-24-11)

MAKE SURE THE AIRPLANE IS IN THIS CONFIGURATION:
ELECTRICAL POWER IS ON (AMM 24-22-00/201)

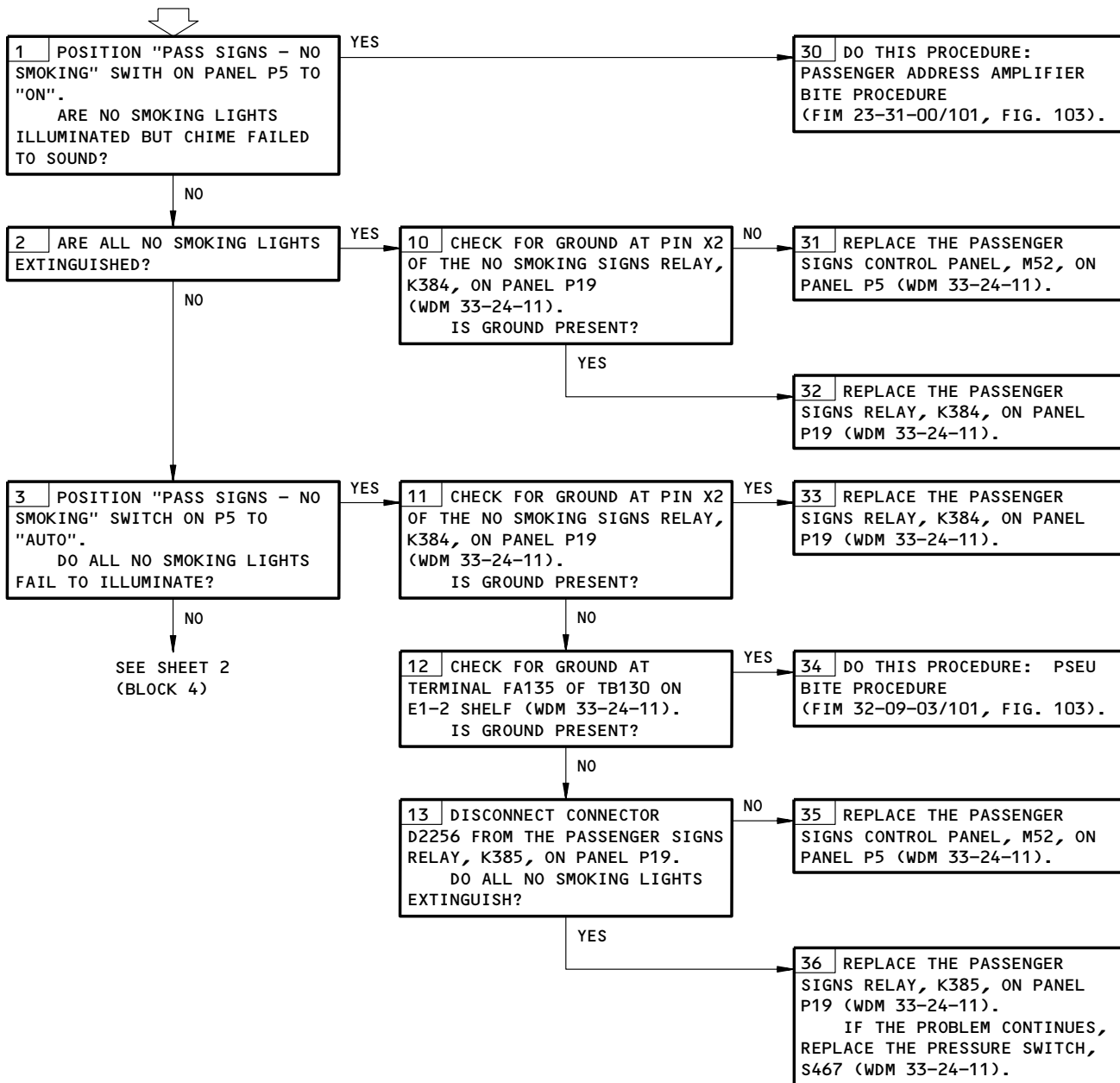

No Smoking Lights Problems
Figure 104 (Sheet 1)

EFFECTIVITY

ALL

33-24-00

01

Page 104
Apr 22/06

951016

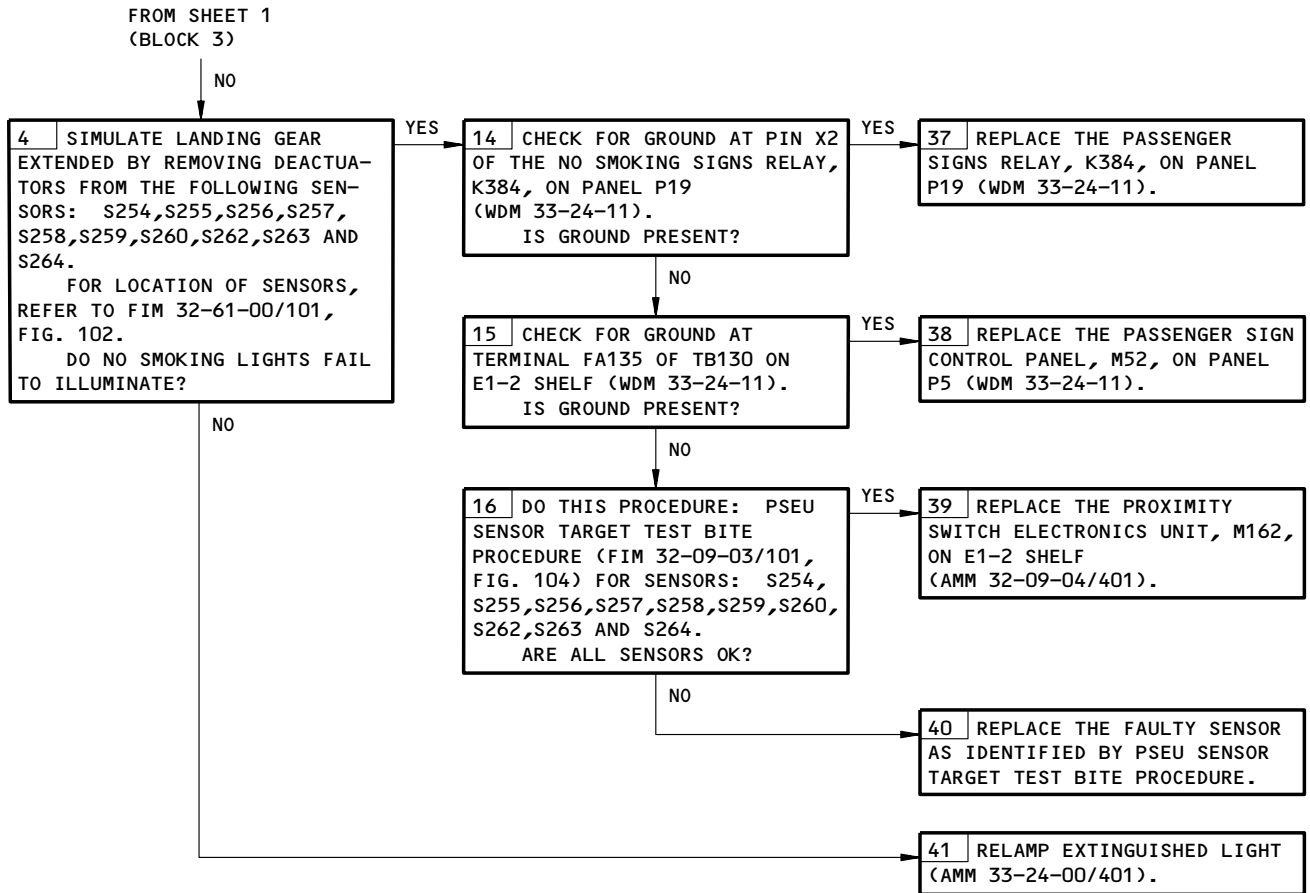

No Smoking Lights Problems
Figure 104 (Sheet 2)

EFFECTIVITY

ALL

33-24-00

**SEAT BELTS AND
RETURN TO SEAT
LIGHT PROBLEMS**

PREREQUISITES

MAKE SURE EACH APPLICABLE CIRCUIT BREAKER IS CLOSED:
(SSM 33-24-01 OR WDM 33-24-11)

MAKE SURE THE AIRPLANE IS IN THIS CONFIGURATION:
ELECTRICAL POWER IS ON (AMM 24-22-00/201)

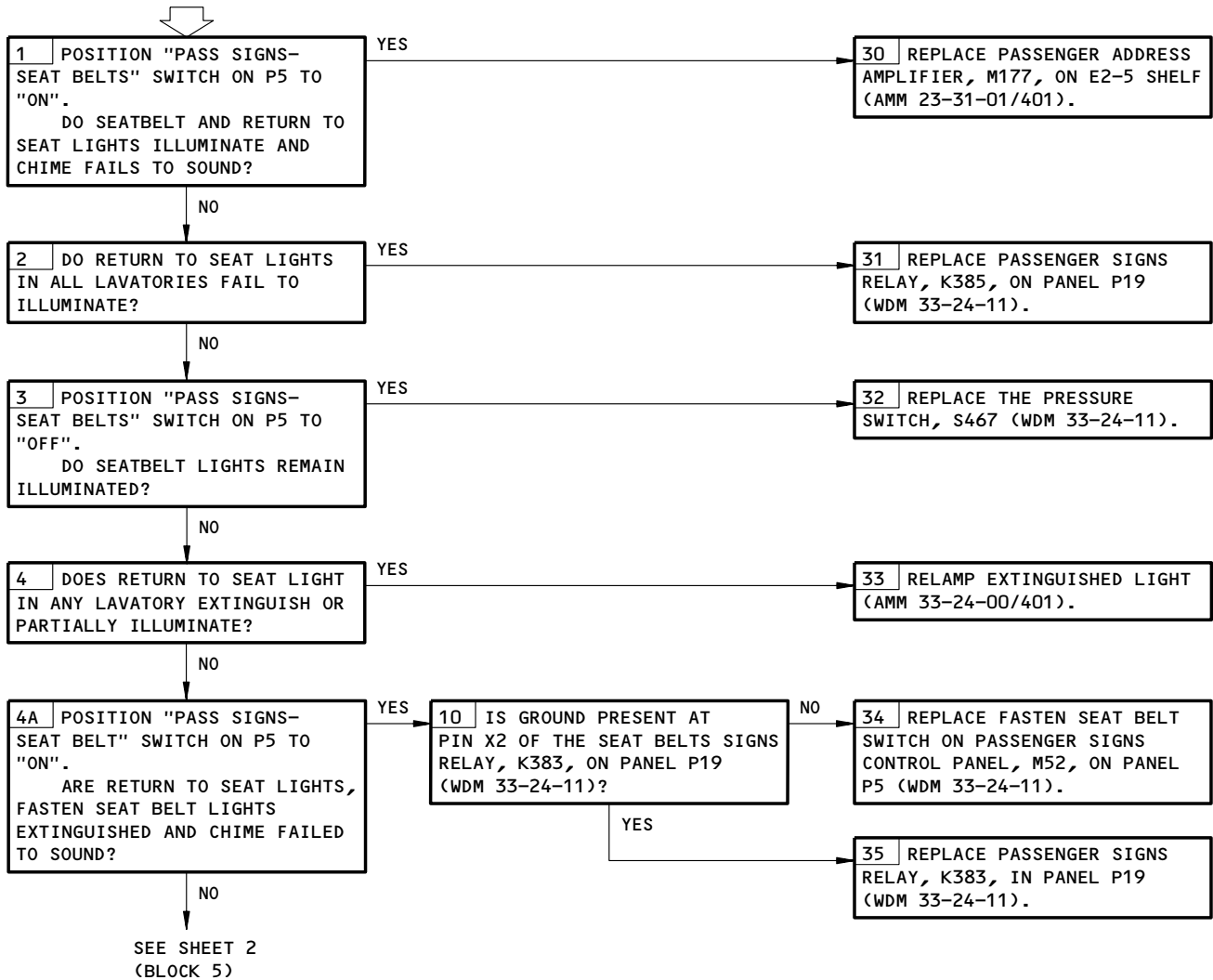

Seat Belts and Return To Seat Lights Problems
Figure 105 (Sheet 1)

EFFECTIVITY

ALL

33-24-00

01

Page 106
Apr 22/06

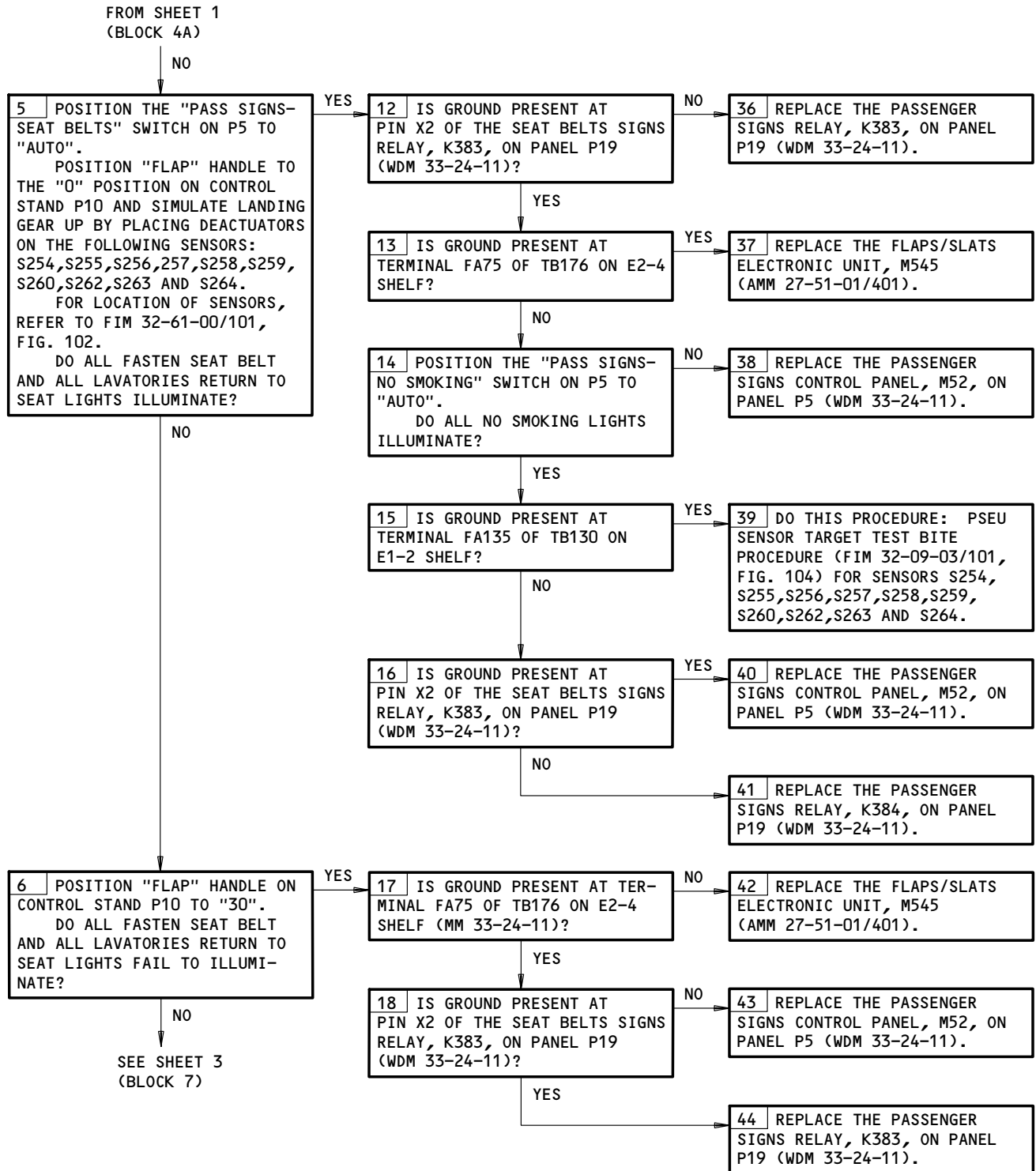

Seat Belts and Return To Seat Lights Problems
Figure 105 (Sheet 2)

EFFECTIVITY

ALL

33-24-00

01

Page 107
Nov 10/95

FROM SHEET 2
(BLOCK 6)

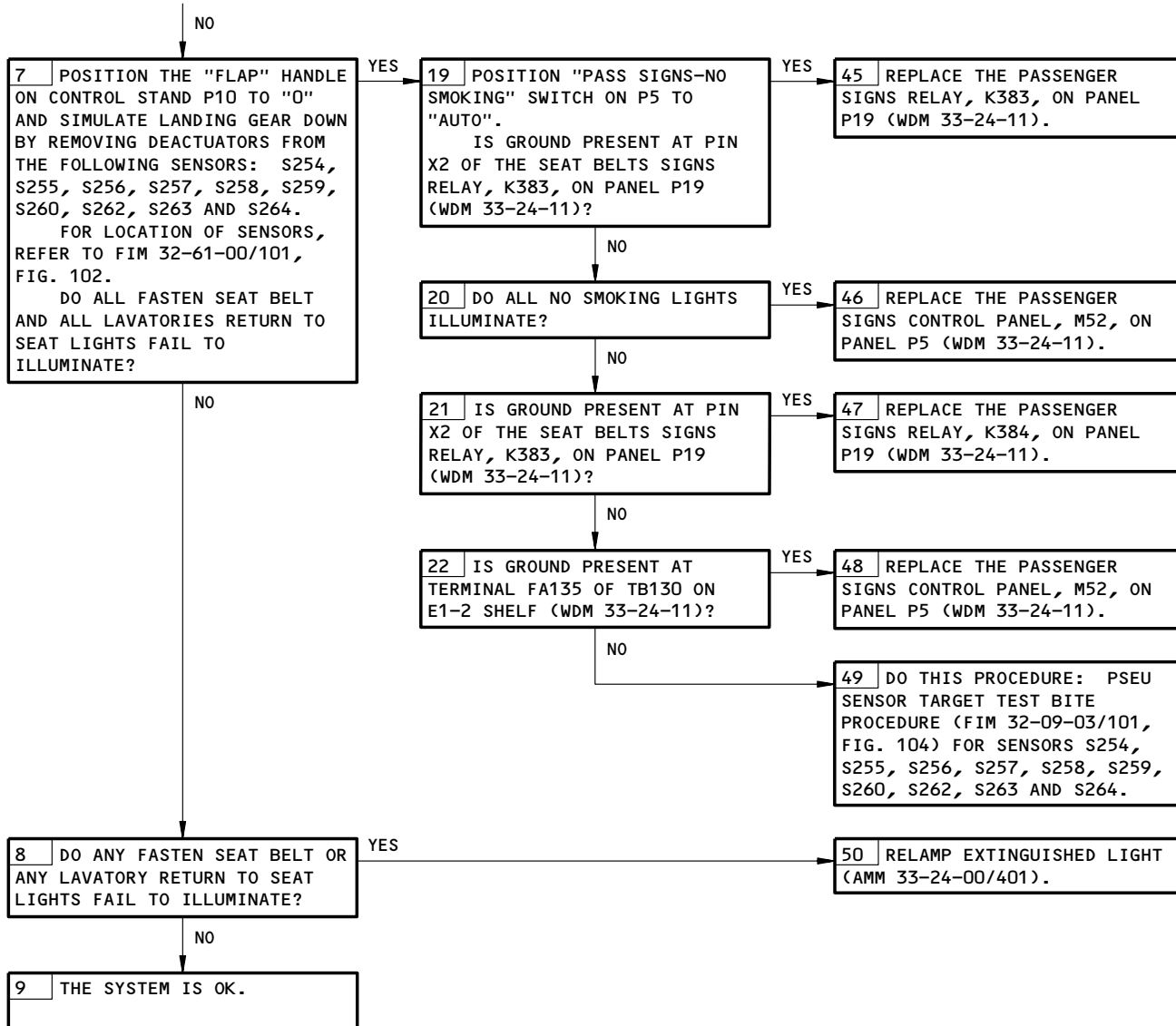

Seatbelts and Return To Seat Lights Problems
Figure 105 (Sheet 3)

EFFECTIVITY ————
ALL

33-24-00



BOEING
 767
 FAULT ISOLATION/MAINT MANUAL

PASSENGER CALL LIGHTS

COMPONENT*	FIG. 102 SHT	QTY *	ACCESS/AREA	AMM REFERENCE
CIRCUIT BREAKER - LIGHT - CALL RELAY - SWITCH - CALL RESET			FLT COMPT, P11	*
			PASS. COMPT EACH LAVATORY	33-25-00 *
			EACH LAVATORY	*
			EACH LAVATORY	*

* SEE THE SSM OR WDM FOR THE EQUIPMENT NUMBER, QUANTITY, AND LOCATION OF EACH COMPONENT IN THE LIGHTING CIRCUIT.

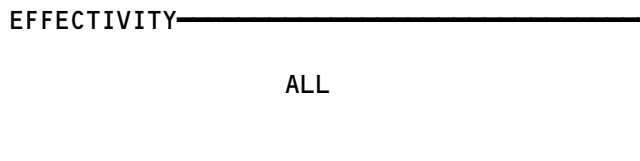
Passenger Call Lights - Component Index
Figure 101



33-25-00

01

Page 101
Nov 10/95

852025

BOEING
767
FAULT ISOLATION/MAINT MANUAL

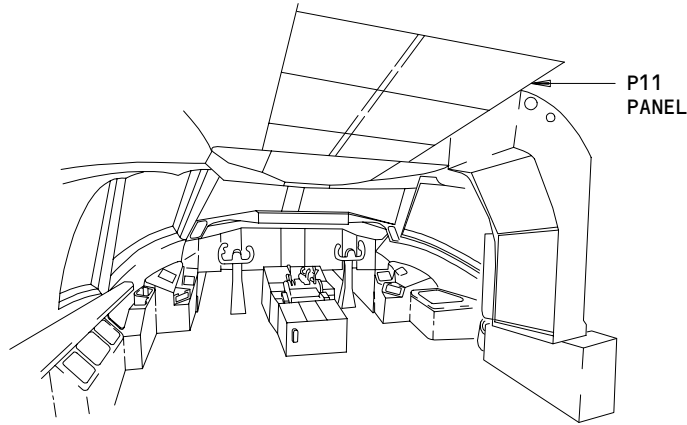

FLIGHT COMPARTMENT

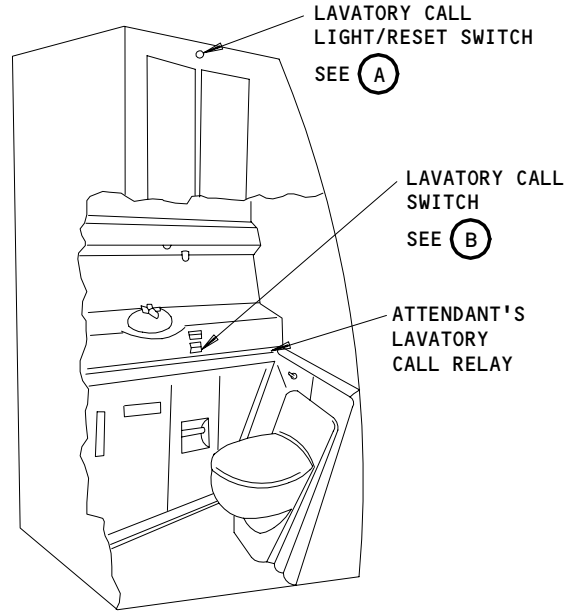

LAVATORY
(EXAMPLE)

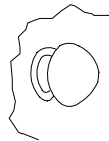

LAVATORY CALL LIGHT/RESET SWITCH
(EXAMPLE)

(A)

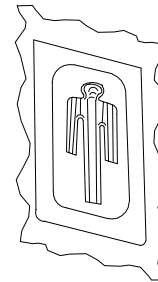

LAVATORY CALL SWITCH
(EXAMPLE)

(B)

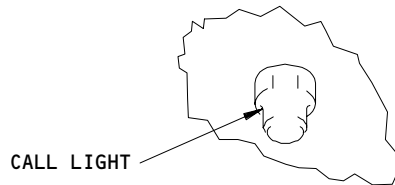

CALL LIGHT
(EXAMPLE)

Passenger Call Lights - Component Location
Figure 102

EFFECTIVITY	ALL
-------------	-----

33-25-00

01

Page 102
Nov 10/95

852079

PREREQUISITES

MAKE SURE THESE CIRCUIT BREAKERS ARE CLOSED:
11C22,11P34

MAKE SURE THE AIRPLANE IS IN THIS CONFIGURATION:
ELECTRICAL POWER IS ON (AMM 24-22-00/201)

**LAVATORY CALL
SYSTEM PROBLEMS**

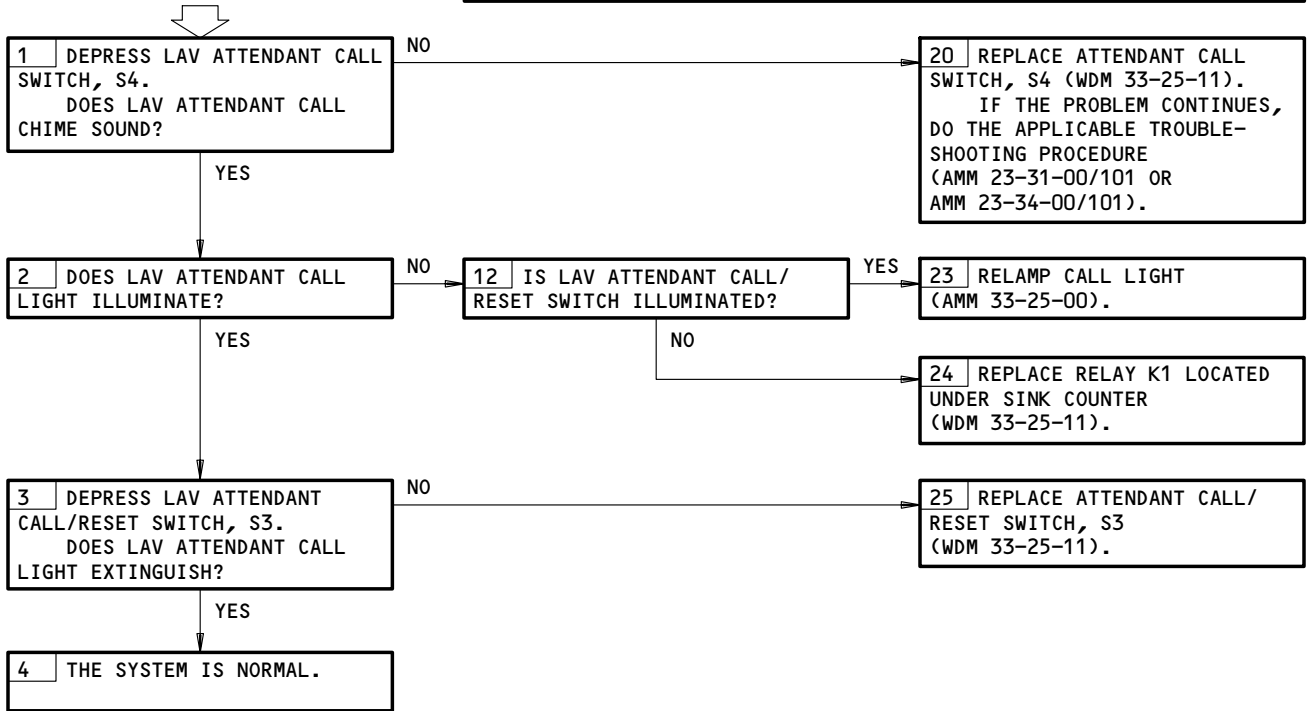

Lavatory Call System Problems
Figure 103

EFFECTIVITY

ALL

33-25-00

01

Page 103
Aug 10/93

C62156

**CABIN CHIME SOUNDS
INTERMITTENTLY**

PREREQUISITES
MAKE SURE THESE CIRCUIT BREAKERS ARE CLOSED:
11C22,11P34
MAKE SURE THE AIRPLANE IS IN THIS CONFIGURATION:
ELECTRICAL POWER IS ON (AMM 24-22-00/201)

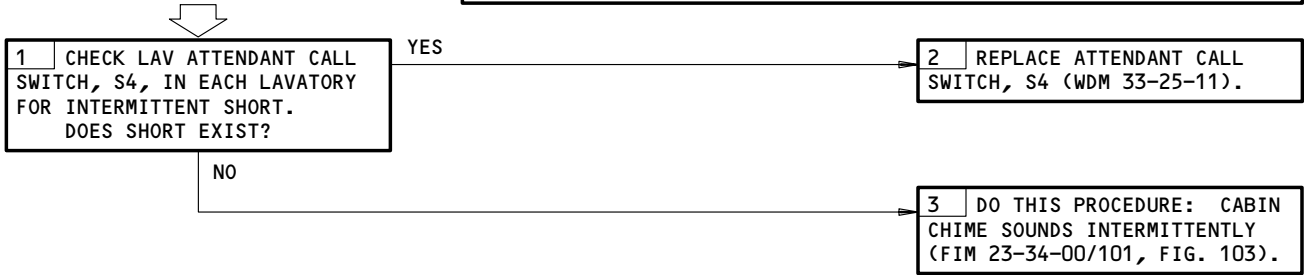





Cabin Chime Sounds Intermittently
Figure 103A

EFFECTIVITY	ALL
-------------	-----



33-25-00

BOEING
767
FAULT ISOLATION/MAINT MANUAL

LAVATORY LIGHTS

COMPONENT*	FIG. 102 SHT	QTY *	ACCESS/AREA	AMM REFERENCE
BALLAST -	2	*	EACH LAVATORY	33-26-02
CIRCUIT BREAKER -	1	*	FLT COMPT, P11	*
CIRCUIT BREAKER -	1	*	119AL, MAIN EQUIP CTR, P34	*
LIGHT -				
MIRROR	2	*	EACH LAVATORY	33-26-00
LAVATORY OCCUPIED 	*	*	FLT COMPT	*
DOME	2	*	EACH LAVATORY	33-26-00
RELAY -	2	*	EACH LAVATORY	33-26-00
SIGN -				
LAVATORY OCCUPIED 	2	*	PASS. COMPT/FLT COMPT	33-26-00
SWITCH -				
DOOR LATCH	2	*	EACH LAVATORY	*
EXTERNAL (HANDICAPPED) 	2	*	EACH LAVATORY	*
HOLD-OPEN DEVICE 	2	*	EACH LAVATORY	*

* SEE THE SSM OR WDM FOR THE EQUIPMENT NUMBER, QUANTITY, AND LOCATION OF EACH COMPONENT IN THE LIGHTING CIRCUIT.

-  NOT INSTALLED IN EACH FLIGHT COMPARTMENT
-  NOT INSTALLED ON ALL LAVATORIES

Lavatory Lights - Component Index
Figure 101

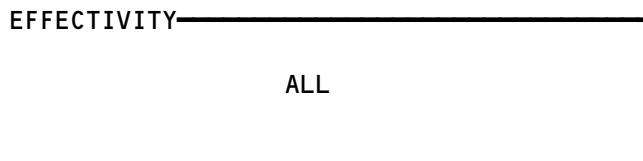

33-26-00

01

Page 101
Apr 10/98

852089

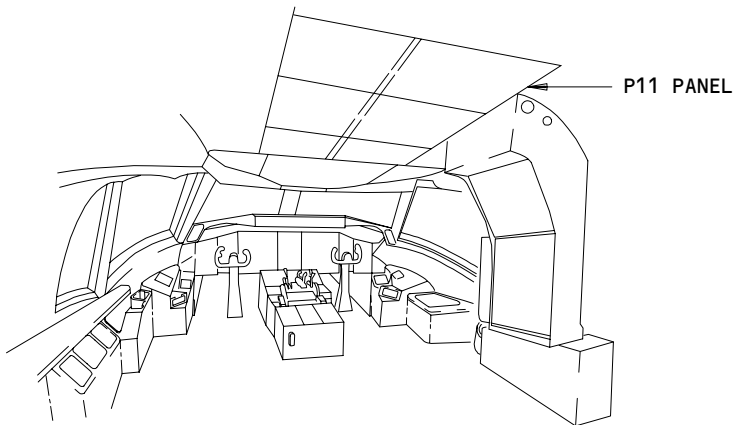

FLIGHT COMPARTMENT

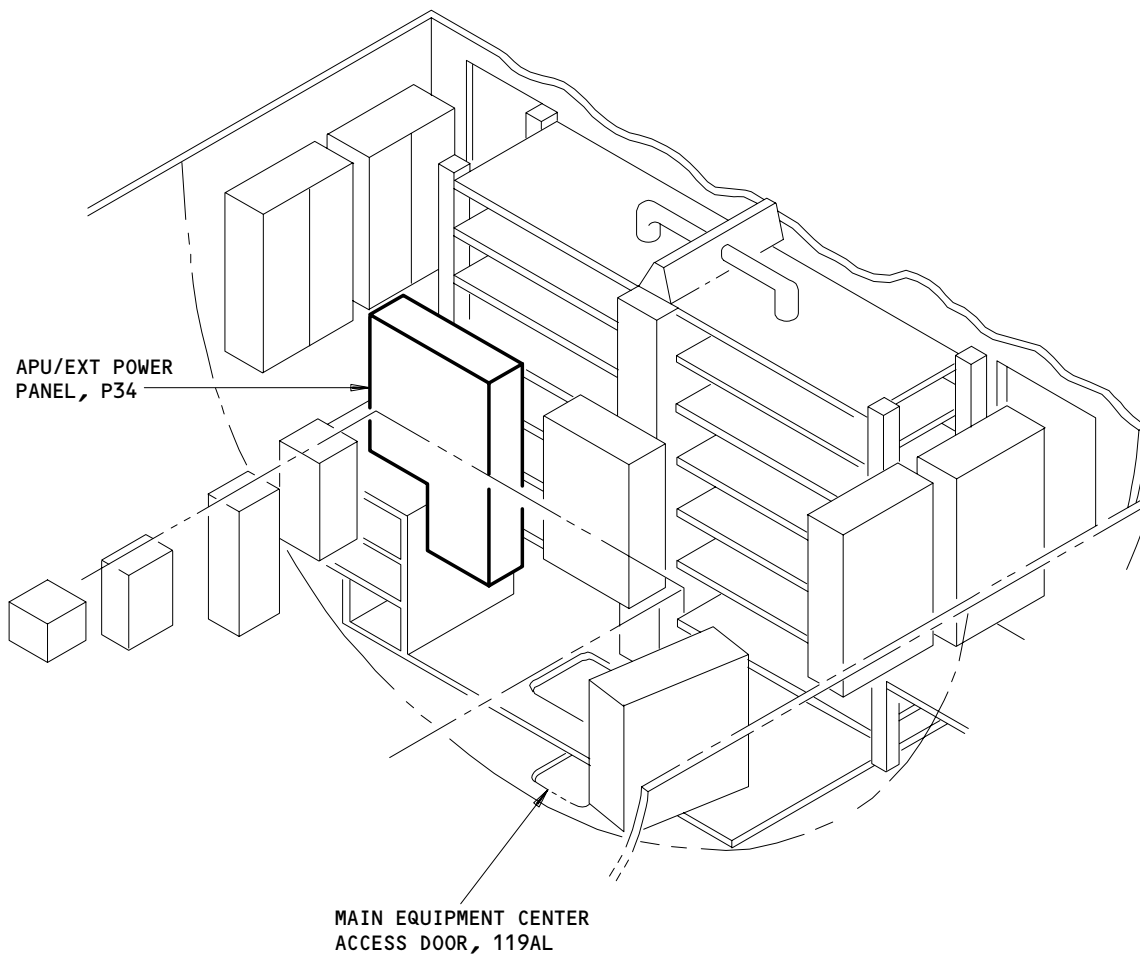

MAIN EQUIPMENT CENTER

Lavatory Lights - Component Location
 Figure 102 (Sheet 1)

EFFECTIVITY	
	ALL

33-26-00

BOEING
767
FAULT ISOLATION/MAINT MANUAL

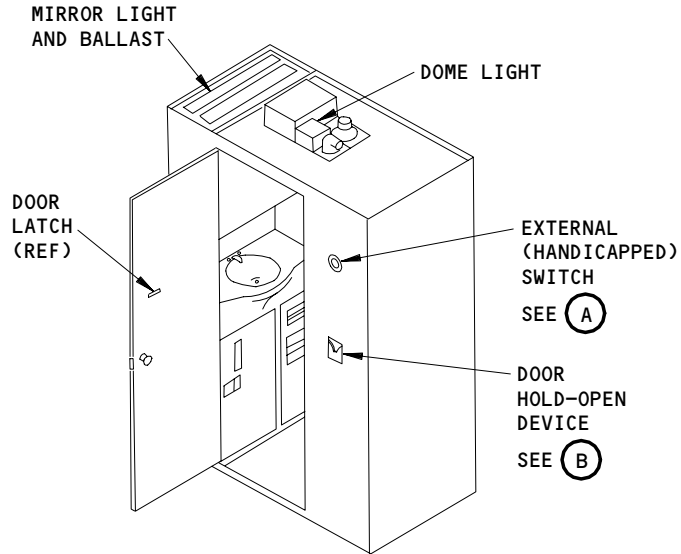

LAVATORY
(EXAMPLE)



LAVATORY OCCUPIED SIGN
(EXAMPLE, INSTALLED IN THE
PASSENGER COMPARTMENT)

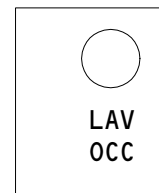
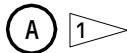

LAVATORY OCCUPIED LIGHT
(EXAMPLE)



EXTERNAL (HANDICAPPED) SWITCH

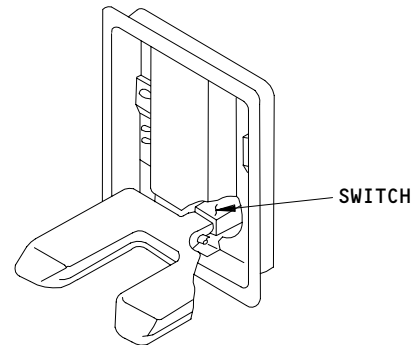
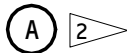

DOOR HOLD-OPEN DEVICE
(EXAMPLE)



1 INSTALLED IN THE FLIGHT COMPARTMENT
OF SOME AIRPLANES

2 NOT INSTALLED ON ALL LAVATORIES

Lavatory Lights - Component Location
Figure 102 (Sheet 2)

EFFECTIVITY	ALL
-------------	-----

33-26-00

LAVATORY LIGHTS PROBLEMS

PREREQUISITES
 MAKE SURE EACH APPLICABLE CIRCUIT BREAKER IS CLOSED:
 (SSM 33-26-01 THRU 33-26-02 OR WDM 33-26-11 THRU 33-26-21)
 MAKE SURE THE AIRPLANE IS IN THIS CONFIGURATION:
 ELECTRICAL POWER IS ON (AMM 24-22-00/201)

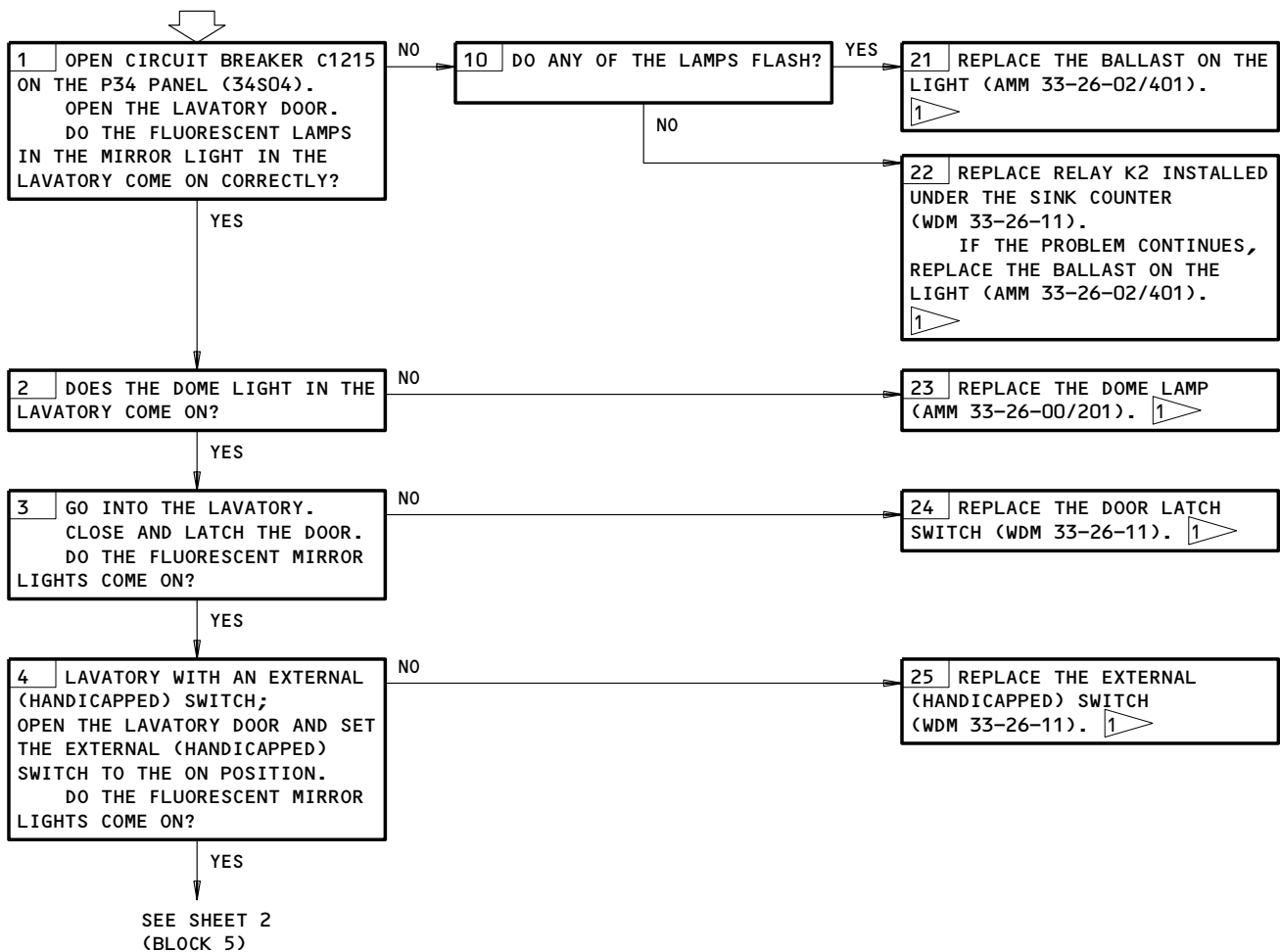

1 ▷ CLOSE CIRCUIT BREAKER C1215 WHEN TASK IS COMPLETE.

Lavatory Lights Problems
Figure 103 (Sheet 1)

EFFECTIVITY	ALL
-------------	-----

33-26-00

35302

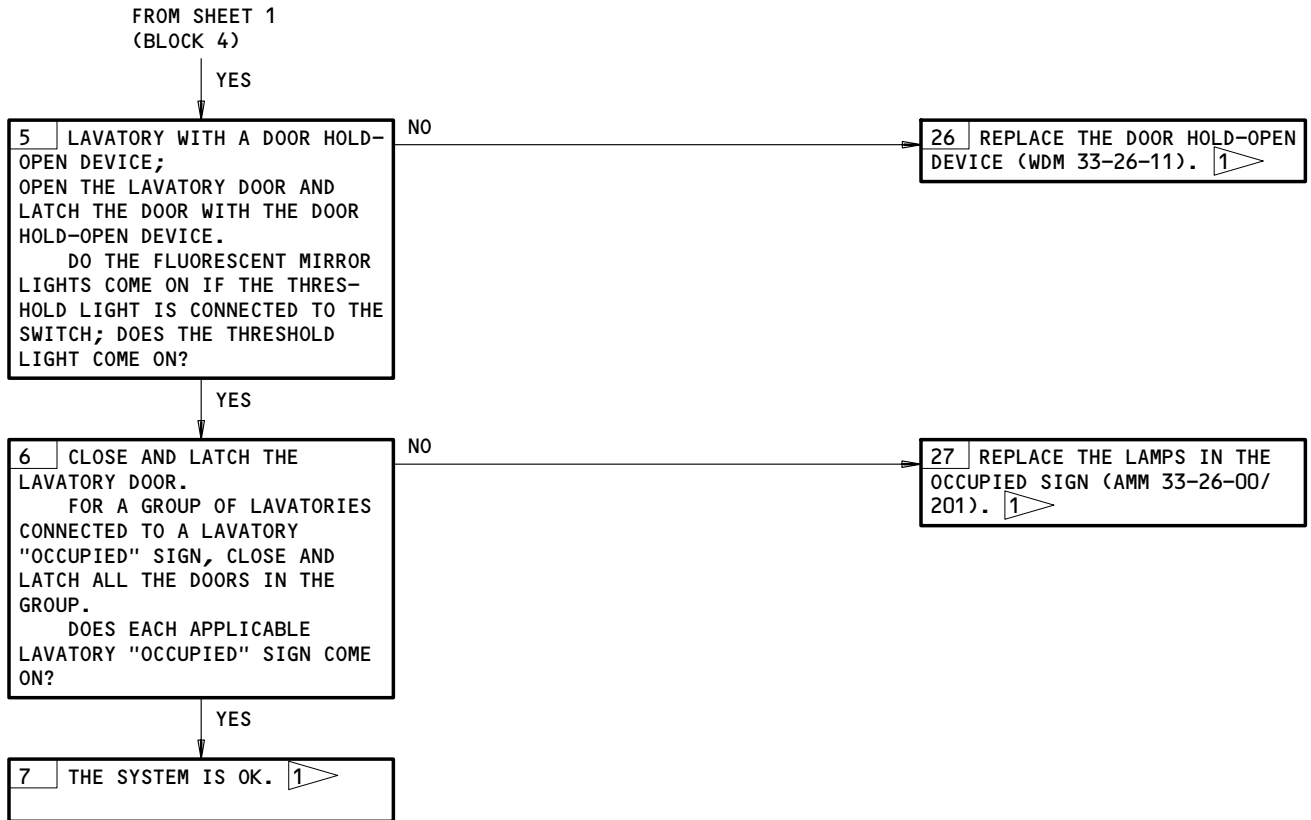

Lavatory Lights Problems
Figure 103 (Sheet 2)

EFFECTIVITY

ALL

33-26-00

01

Page 105
Aug 10/95



BOEING
 767
 FAULT ISOLATION/MAINT MANUAL

GALLEY LIGHTS

COMPONENT*	FIG. 102 SHT	QTY *	ACCESS/AREA	AMM REFERENCE
BALLAST -		*	EACH GALLEY	33-27-00
CIRCUIT BREAKER -		*	119AL, MAIN EQUIP CTR, P33	*
LIGHT -		*	PASS. COMPT	*
AFT DIRECT CEILING		*	MID GALLEY	*
GALLEY		*	AFT, FWD AND MID GALLEY	*
RELAY -		*	119AL, MAIN EQUIP CTR, P19,P25	*
SWITCH-LIGHT -		*	EACH GALLEY	*
TRANSFORMER -		*	119AL, MAIN EQUIP CTR, P19	*

* SEE THE SSM OR WDM FOR THE EQUIPMENT NUMBER, QUANTITY, AND LOCATION OF EACH COMPONENT IN THE LIGHTING CIRCUIT.

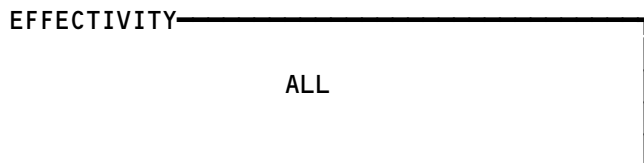
Galley Lights - Component Index
Figure 101



33-27-00

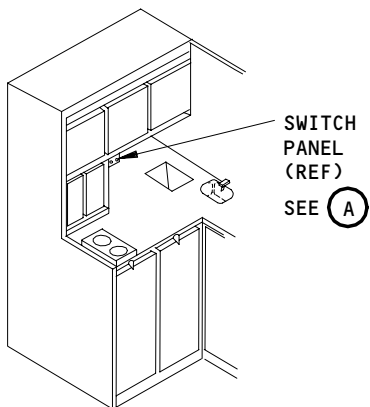

**FORWARD GALLEY
(EXAMPLE)**

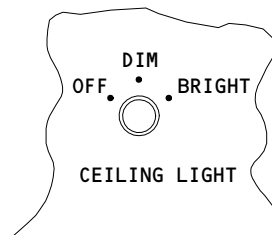
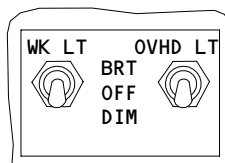

(EXAMPLES)

(A)

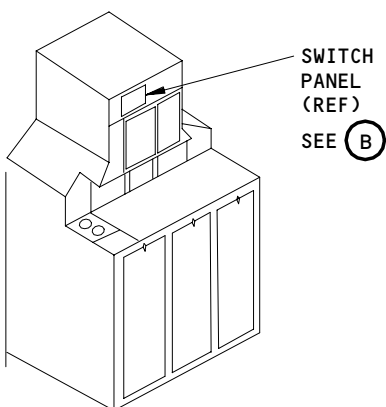

**MID CABIN GALLEY ¹
(EXAMPLE)**

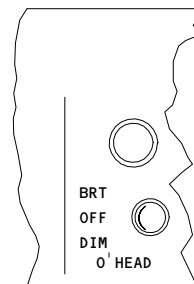

(EXAMPLES)

(B) ¹

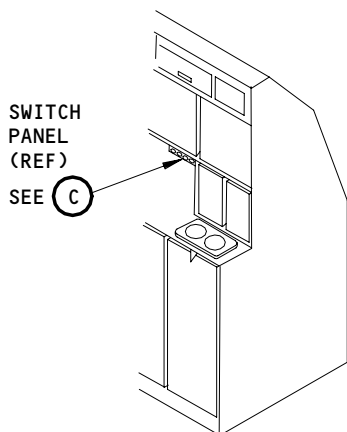

**AFT GALLEY
(EXAMPLE)**

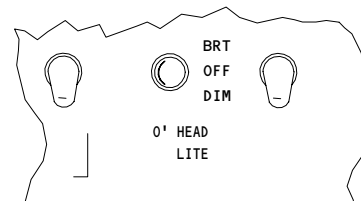
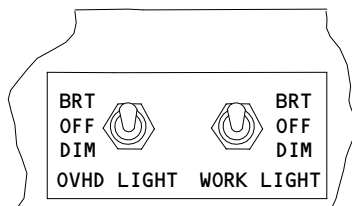

(EXAMPLES)

(C)

¹ NOT INSTALLED ON ALL AIRPLANES

**Galley Lights - Component Location
Figure 102**

EFFECTIVITY	ALL
-------------	-----

33-27-00

**GALLEY LIGHTS
PROBLEMS**

PREREQUISITES
 MAKE SURE THESE CIRCUIT BREAKERS ARE CLOSED:
 33L7
 MAKE SURE THE AIRPLANE IS IN THIS CONFIGURATION:
 ELECTRICAL POWER IS ON (AMM 24-22-00/201)

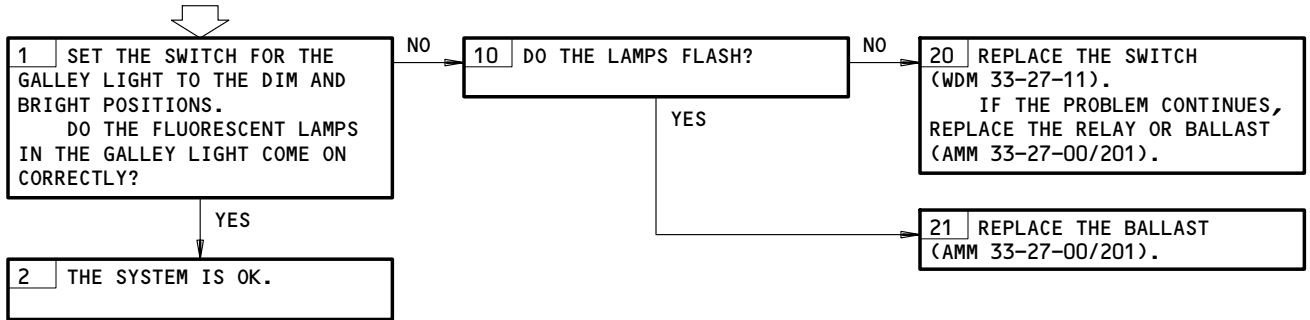

Galley Lights Problems
Figure 103

EFFECTIVITY	ALL
-------------	-----

33-27-00

BOEING
767
FAULT ISOLATION/MAINT MANUAL

SERVICE LIGHTS

COMPONENT*	FIG. 102 SHT	QTY *	ACCESS/AREA	AMM REFERENCE
CIRCUIT BREAKER -	7	*	119AL, MAIN EQUIP CTR, P33,P34	*
CIRCUIT BREAKER 1 -	7	*	821 (822), FWD (AFT) CARGO COMPT, P35 (P39)	*
LIGHT -	---	---		
AIR COND COMPT	5	*	193GL,194FR, ECS BAY	*
APU COMP	3,4	*	315AL,316AR, APU COMPT	*
EXTERIOR CARGO LOADING 1	8	*	INSIDE/BESIDE CARGO DOOR	*
MAIN EQUIP CTR	6	*	119AL, MAIN EQUIP CTR	*
MAIN AND NOSE GEAR WHEEL WELL	2	*	MLG WHEEL WELL	*
TAILCONE COMPT	3,4	*	312AR,313AL	*
SWITCH -				
AIR COND COMPT LIGHTS	5	*	193GL,194FR, ECS BAY	*
APU COMPT LIGHTS	3	*	315AL,316AR, APU COMPT	*
EXTERIOR CARGO LOADING LIGHTS 1	8	*	EXT CARGO DOOR CONTROL PNL, P43, P44	*
IN-FLIGHT MAIN EQUIP CTR LIGHT	6	*	119AL, MAIN EQUIP CTR	*
MAIN EQUIP CTR LIGHTS	6	*	113AL, FWD OF NLG WHEEL WELL	*
MAIN WHEEL WELL LIGHTS	2	*	MLG WHEEL WELL, FWD WALL	*
NOSE GEAR WHEEL WELL LIGHTS	1	*	NLG WHEEL WELL, APU SHUTDOWN	*
TAILCONE COMPT LIGHTS	3,4	*	312AR,313AL, STABILIZER TORSION BOX	*
RELAY -	7	*	119AL, MAIN EQUIP CTR	*
TRANSFORMER -	---	*	NEAR THE LIGHT SWITCH	*

* SEE THE SSM OR WDM FOR THE EQUIPMENT NUMBER, QUANTITY AND LOCATION OF EACH COMPONENT IN THE LIGHTING CIRCUIT.

1 NOT INSTALLED ON ALL AIRPLANES

Service Lights - Component Index
Figure 101

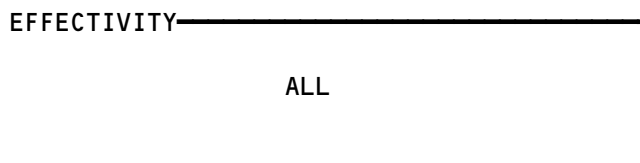

33-31-00

01

Page 101
Nov 10/95

719156

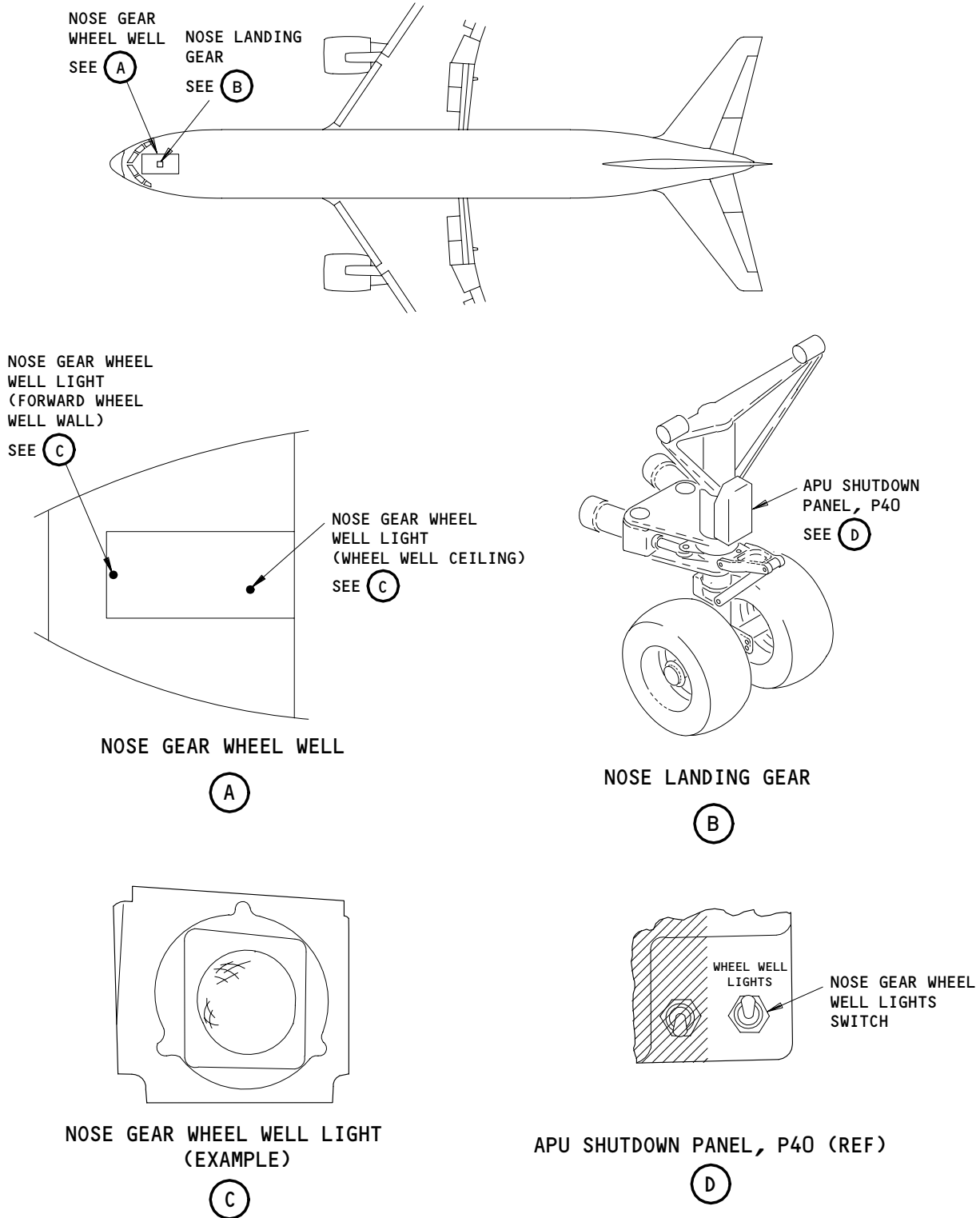

Service Lights - Component Location
Figure 102 (Sheet 1)

EFFECTIVITY	ALL
-------------	-----

33-31-00

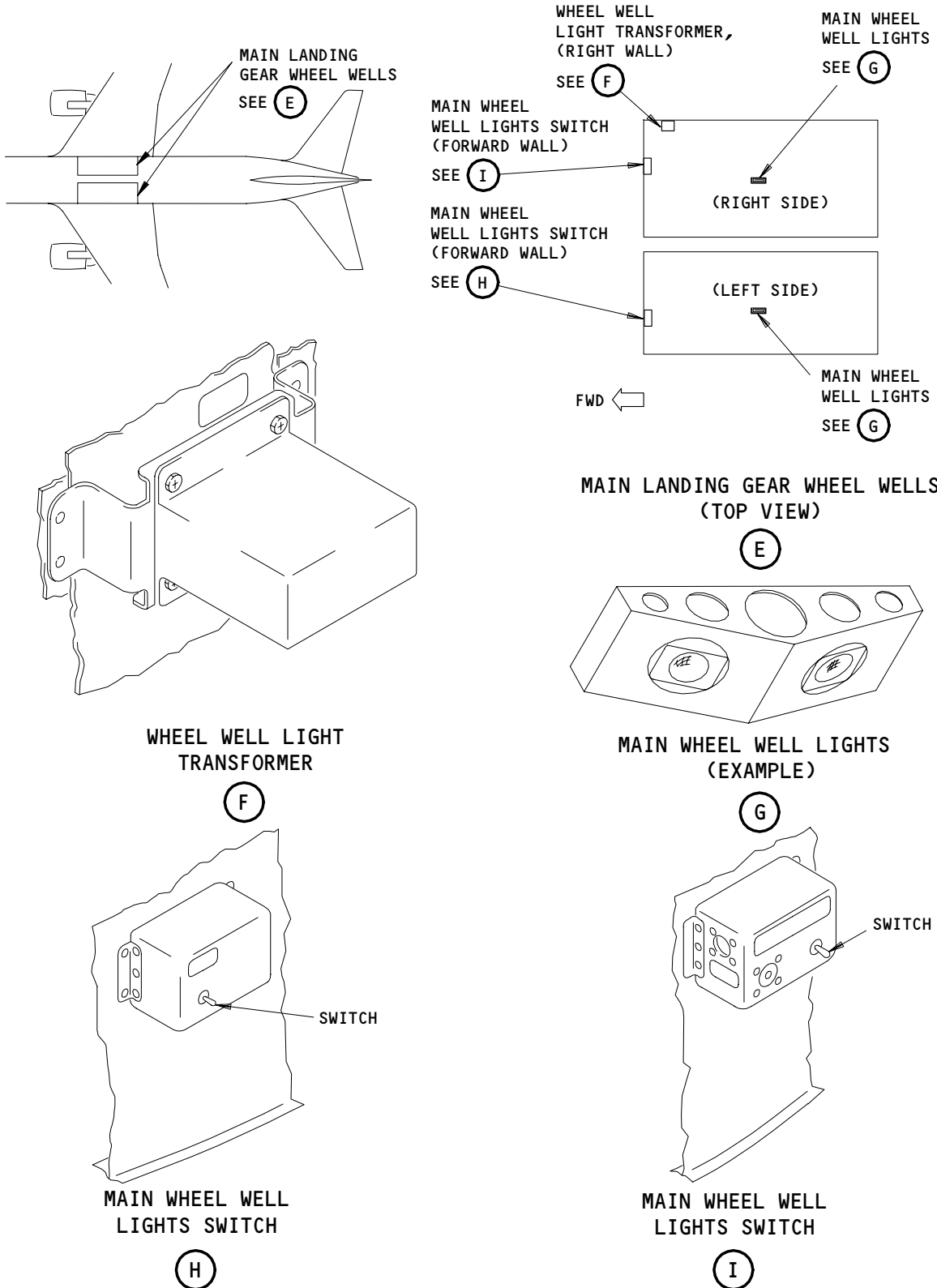

Service Lights - Component Location
Figure 102 (Sheet 2)

EFFECTIVITY

ALL

33-31-00

01

Page 103
May 10/94

BOEING

767

FAULT ISOLATION/MAINT MANUAL

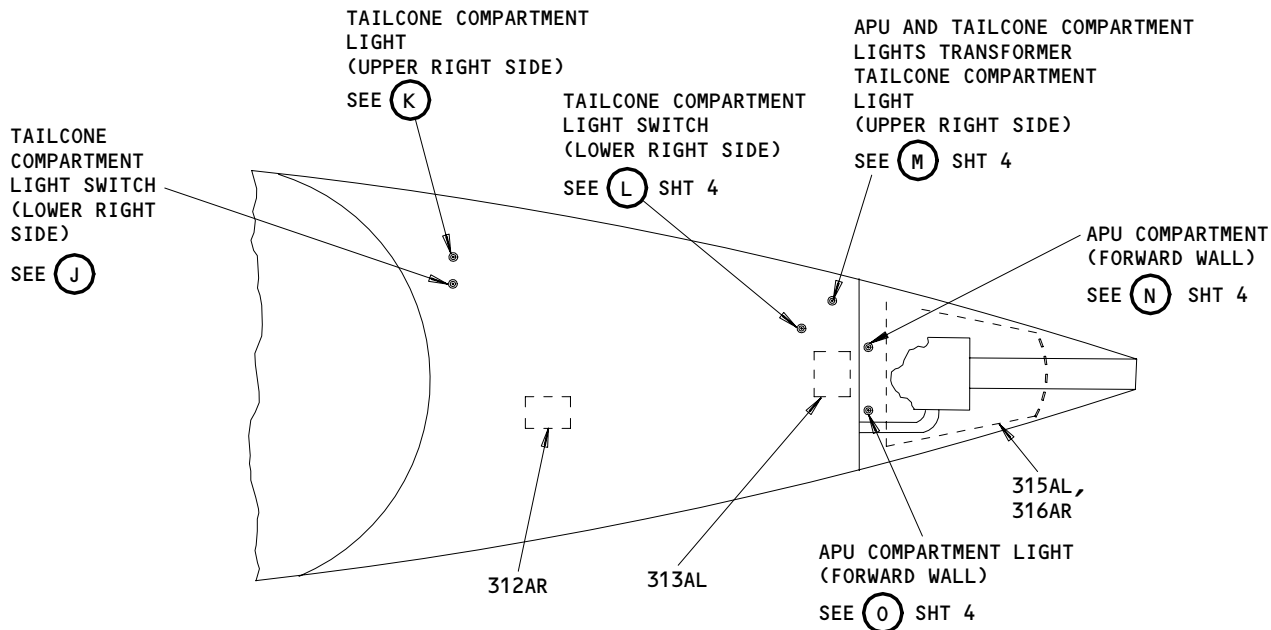

**APU COMPARTMENT
(TOP VIEW)**

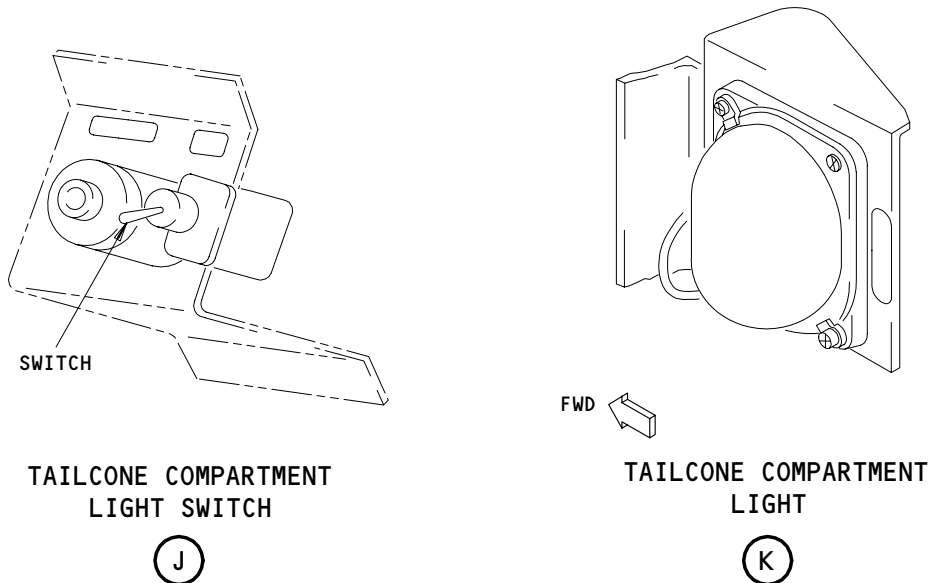

Service Lights - Component Location
Figure 102 (Sheet 3)

EFFECTIVITY	ALL
-------------	-----

33-31-00

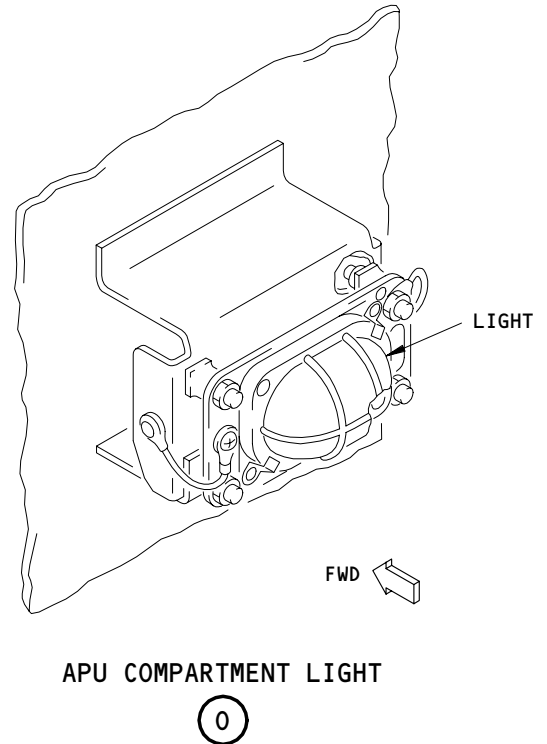
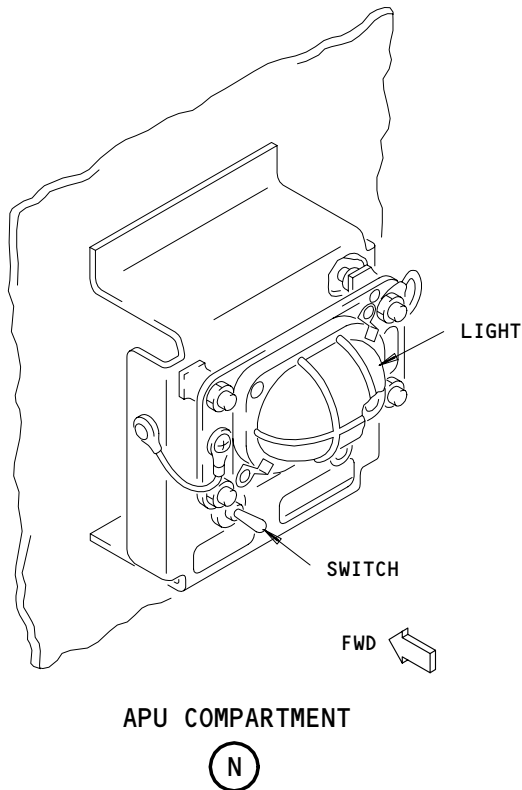
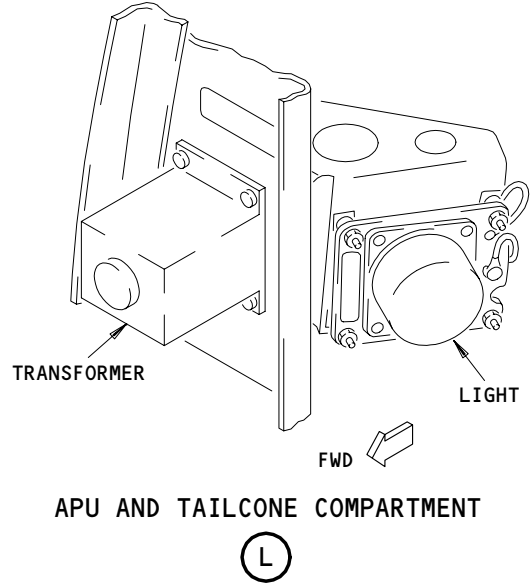
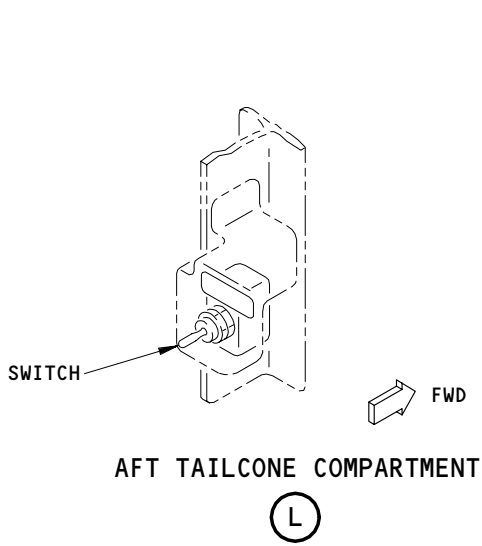

Service Lights - Component Location (Details from Sht 3)
Figure 102 (Sheet 4)

EFFECTIVITY	ALL
-------------	-----

94788

33-31-00

01

Page 105
May 10/94

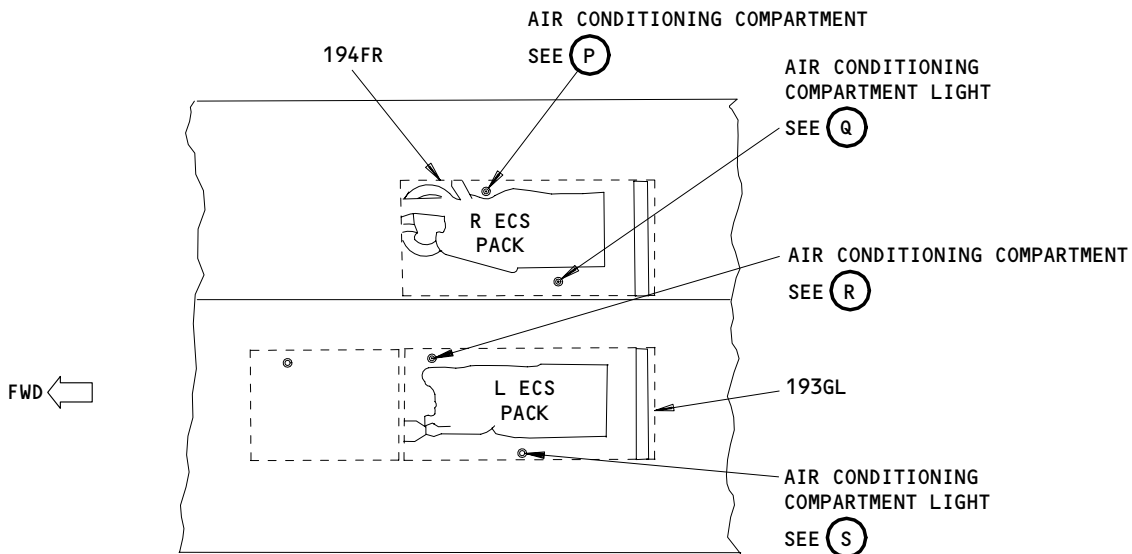

ECS BAY
(TOP VIEW)

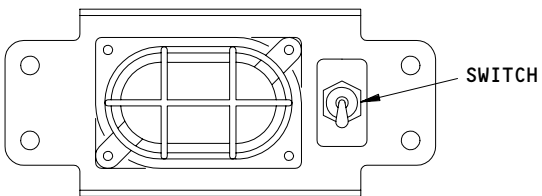

AIR CONDITIONING COMPARTMENT SWITCH

(P)

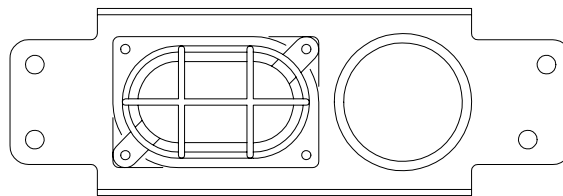

AIR CONDITIONING COMPARTMENT LIGHT

(Q)

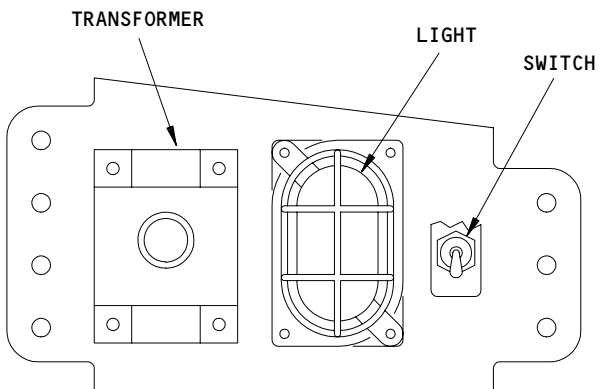

AIR CONDITIONING COMPARTMENT

(R)

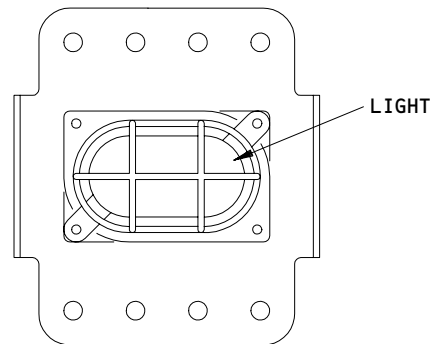

AIR CONDITIONING COMPARTMENT LIGHT

(S)

Service Lights - Component Location
Figure 102 (Sheet 5)

EFFECTIVITY

ALL

33-31-00

01

Page 106
May 10/94

717392

BOEING

767

FAULT ISOLATION/MAINT MANUAL

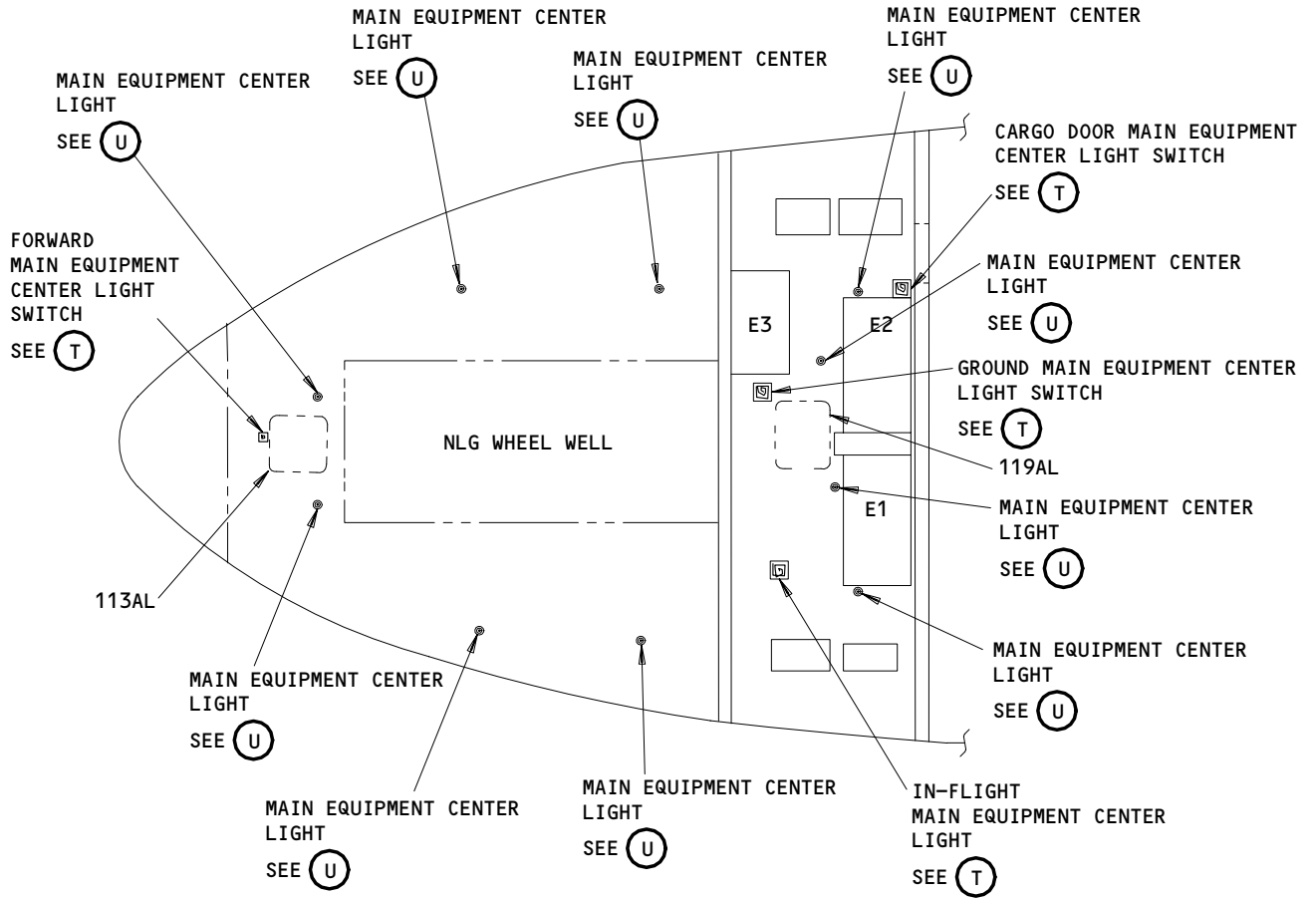

MAIN EQUIPMENT CENTER

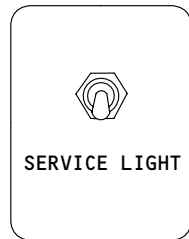

MAIN EQUIPMENT CENTER
LIGHTS SWITCH
(EXAMPLE)

(T)

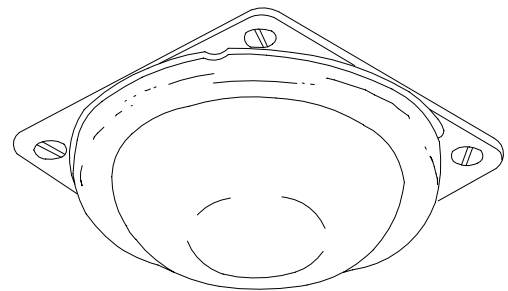

MAIN EQUIPMENT CENTER LIGHT
(EXAMPLE)

(U)

Service Lights - Component Location
Figure 102 (Sheet 6)

EFFECTIVITY	
	ALL

33-31-00

01

Page 107
May 10/94

BOEING
 767
 FAULT ISOLATION/MAINT MANUAL

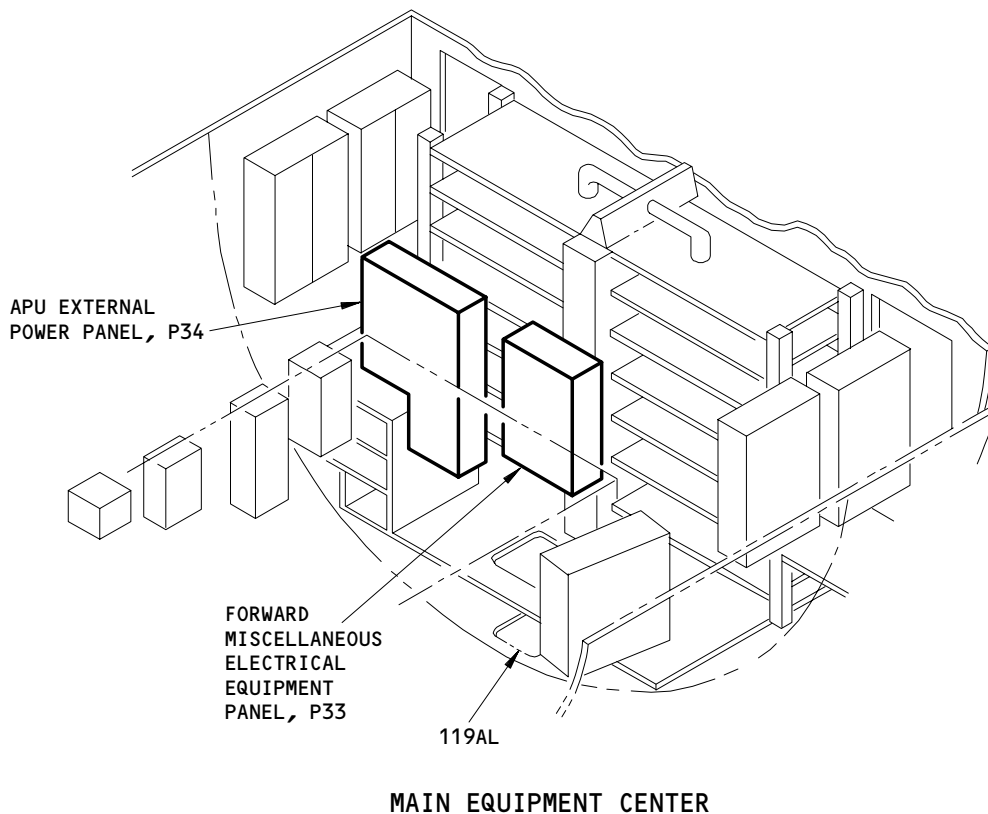
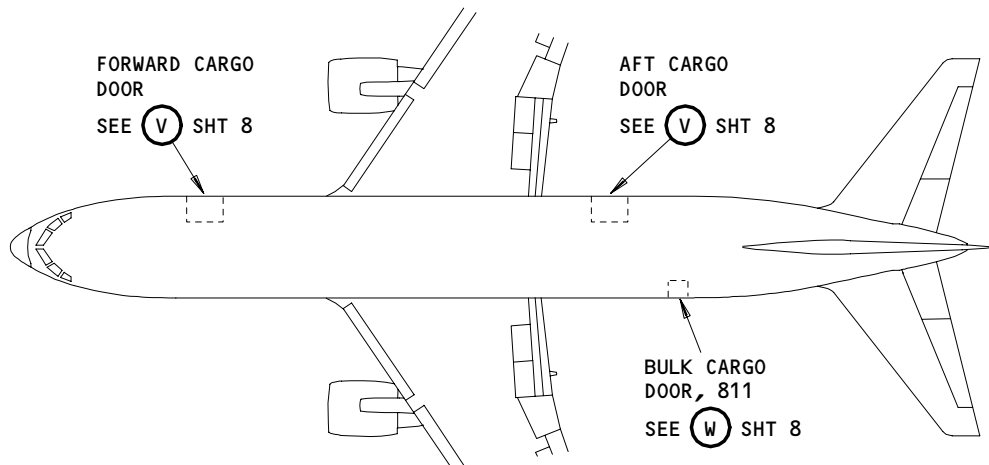

Service Lights - Component Location
Figure 102 (Sheet 7)

EFFECTIVITY	ALL
-------------	-----

33-31-00

666241

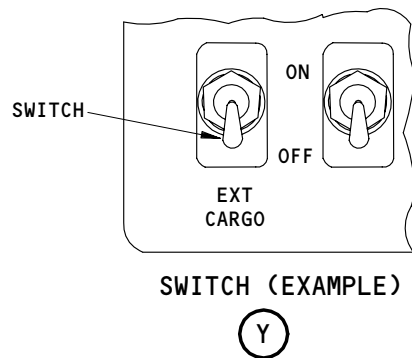
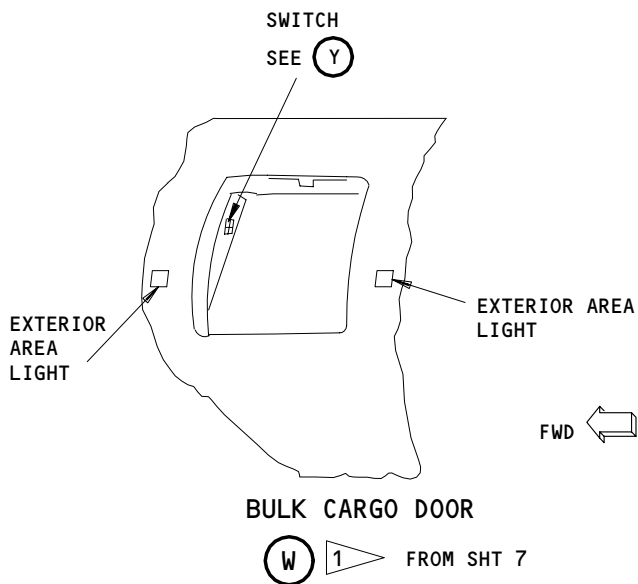
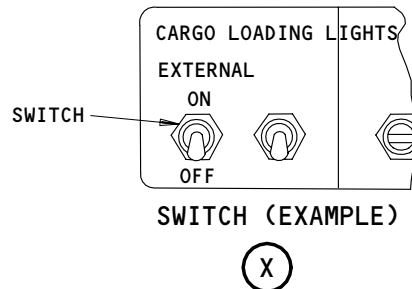
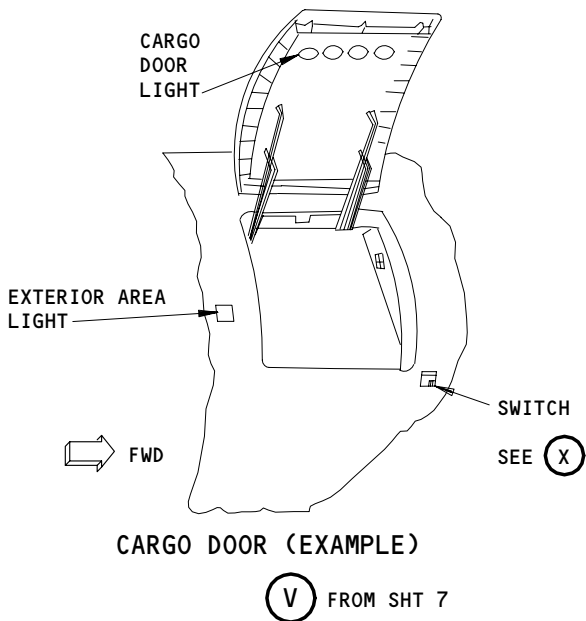

1 NOT INSTALLED ON ALL AIRPLANES

Service Lights - Component Location
Figure 102 (Sheet 8)

EFFECTIVITY
AIRPLANES WITH EXTERIOR CARGO LOADING
LIGHTS

33-31-00

Not Used
Figure 103

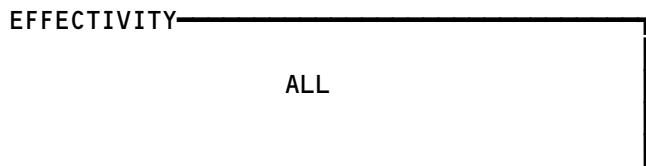

33-31-00

01

Page 110
Aug 10/95

93315

**MAIN GEAR WHEEL
WELL SERVICE LIGHTS
PROBLEMS**

PREREQUISITES

MAKE SURE THIS CIRCUIT BREAKER IS CLOSED:
33J5

MAKE SURE THE AIRPLANE IS IN THE CONFIGURATION THAT
FOLLOWS:
ELECTRICAL POWER IS ON (MM 24-22-00/201)

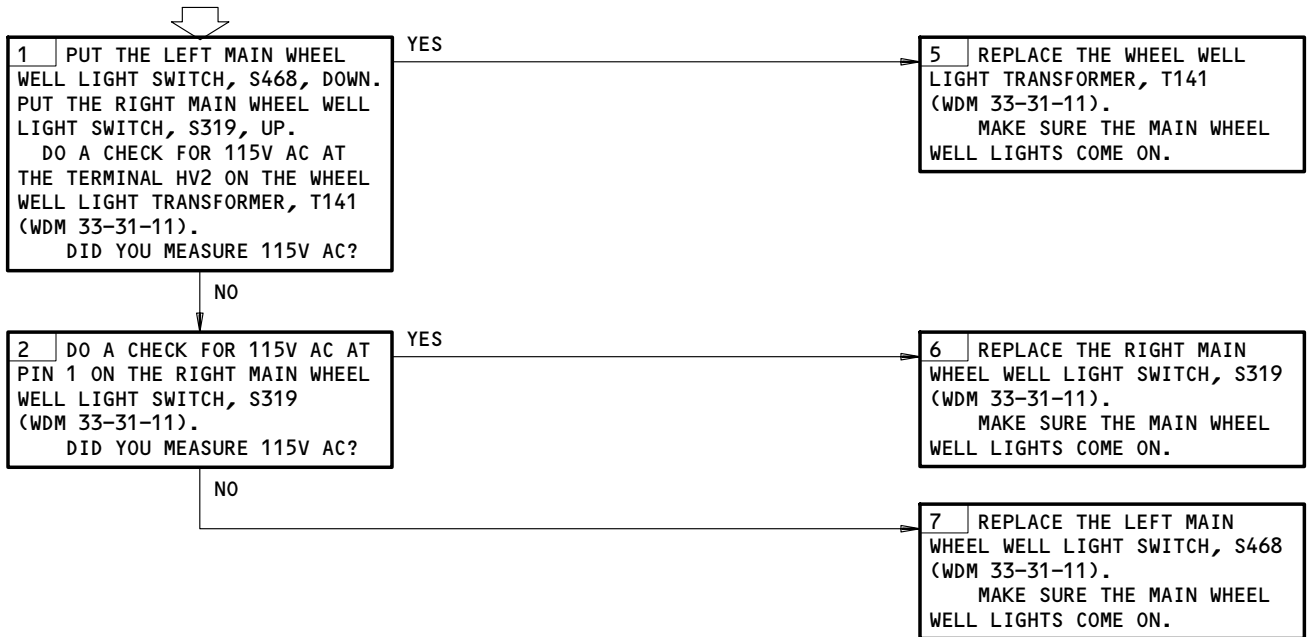

Main Gear Wheel Well Service Lights Problems
Figure 104

EFFECTIVITY

ALL

33-31-00

01

Page 111
May 10/94

**RIGHT AIR CONDI-
TIONING COMPARTMENT
LIGHTS PROBLEMS**

PREREQUISITES
MAKE SURE THIS CIRCUIT BREAKER IS CLOSED:
34S2
MAKE SURE THE AIRPLANE IS IN THE CONFIGURATION THAT
FOLLOWS:
ELECTRICAL POWER IS ON (MM 24-22-00/201)

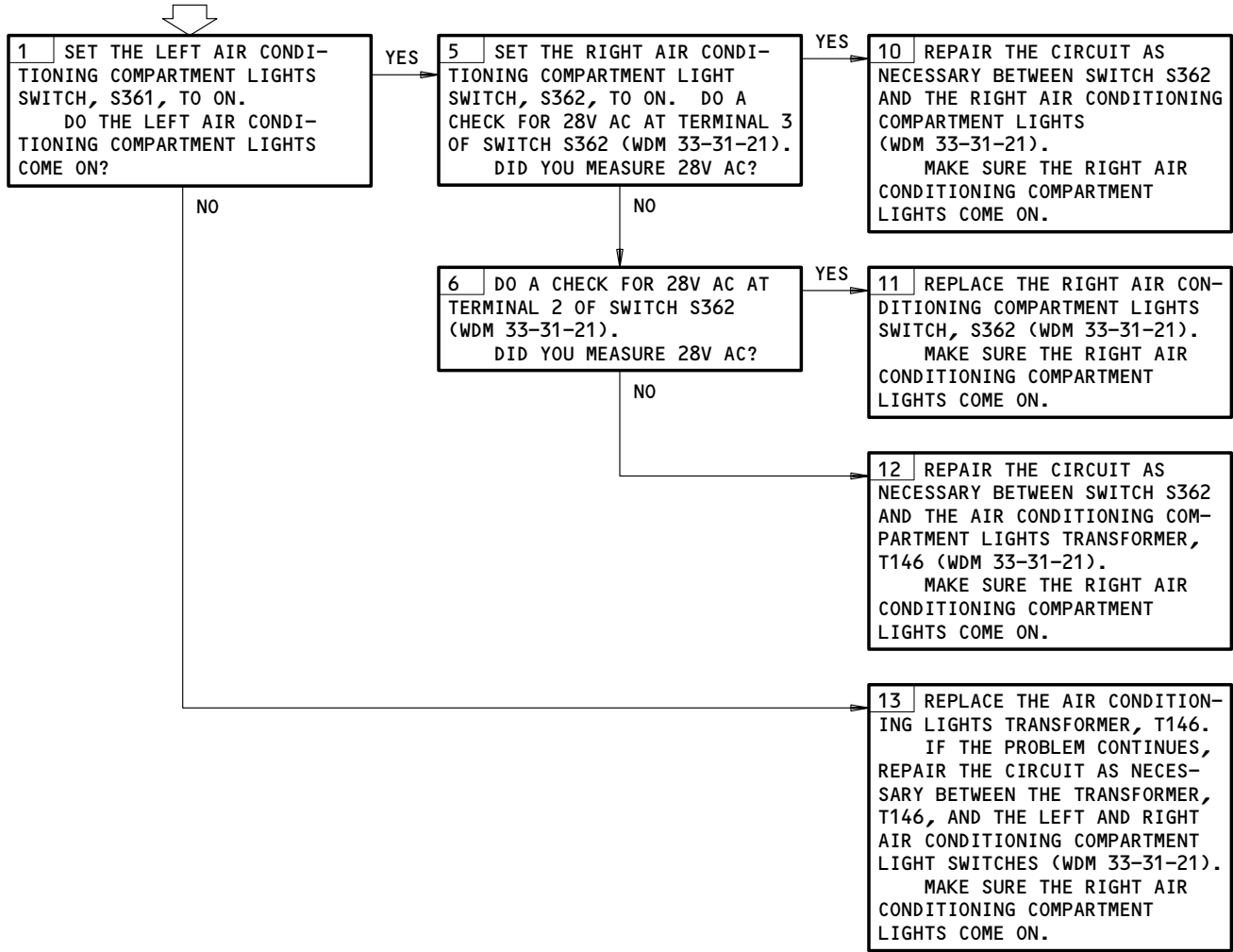

Right Air Conditioning Compartment Lights Problems
Figure 105

EFFECTIVITY	ALL
-------------	-----

33-31-00

**LEFT AIR CONDI-
TIONING COMPARTMENT
LIGHTS PROBLEMS**

PREREQUISITES

MAKE SURE THIS CIRCUIT BREAKER IS CLOSED:
34S2

MAKE SURE THE AIRPLANE IS IN THE CONFIGURATION THAT
FOLLOWS:
ELECTRICAL POWER IS ON (MM 24-22-00/201)

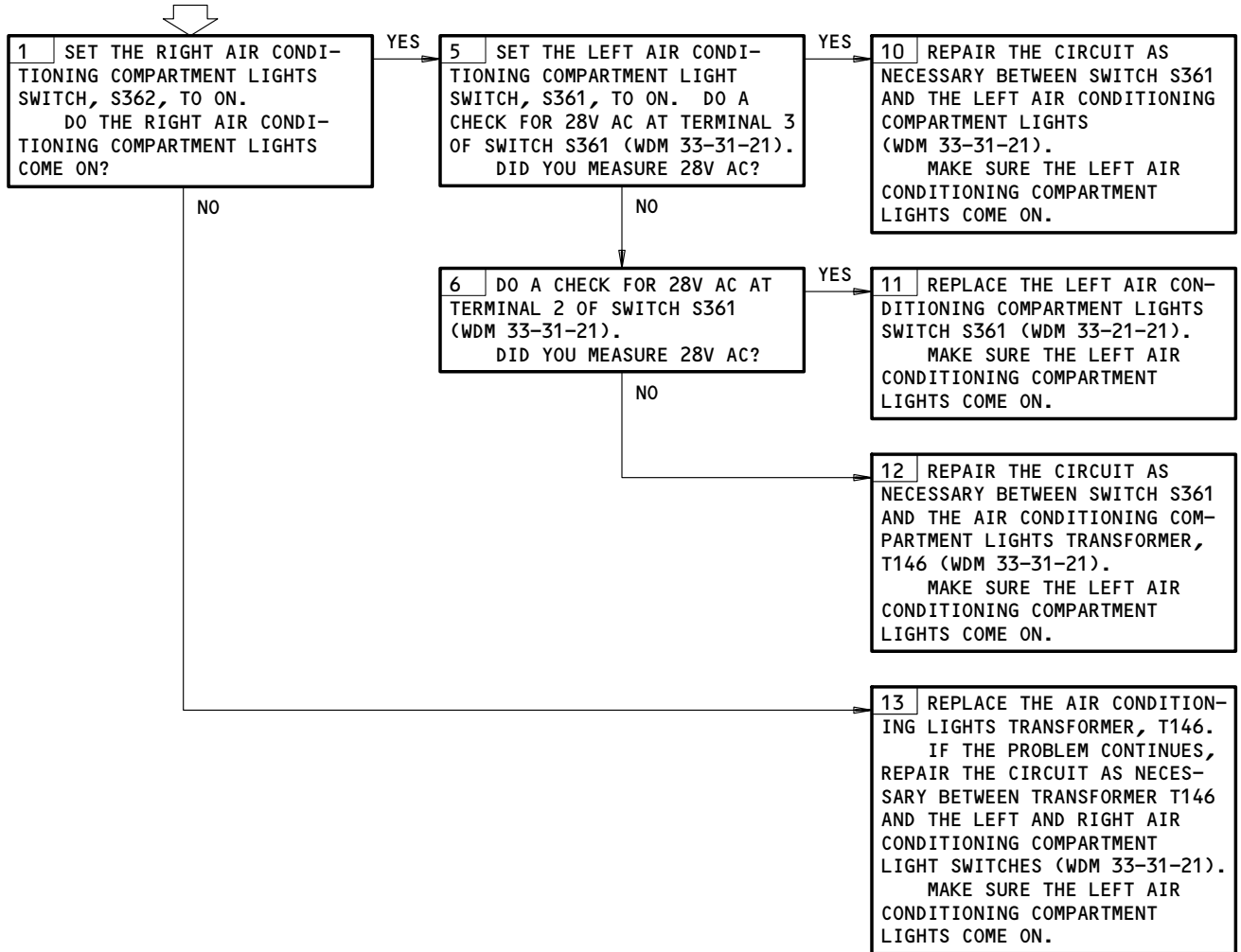

Left Air Conditioning Compartment Lights Problems
Figure 106

EFFECTIVITY	ALL
-------------	-----

33-31-00

APU COMPARTMENT LIGHTS PROBLEMS

PREREQUISITES
 MAKE SURE THIS CIRCUIT BREAKER IS CLOSED:
 34S3
 MAKE SURE THE AIRPLANE IS IN THE CONFIGURATION THAT FOLLOWS:
 ELECTRICAL POWER IS ON (MM 24-22-00/201)

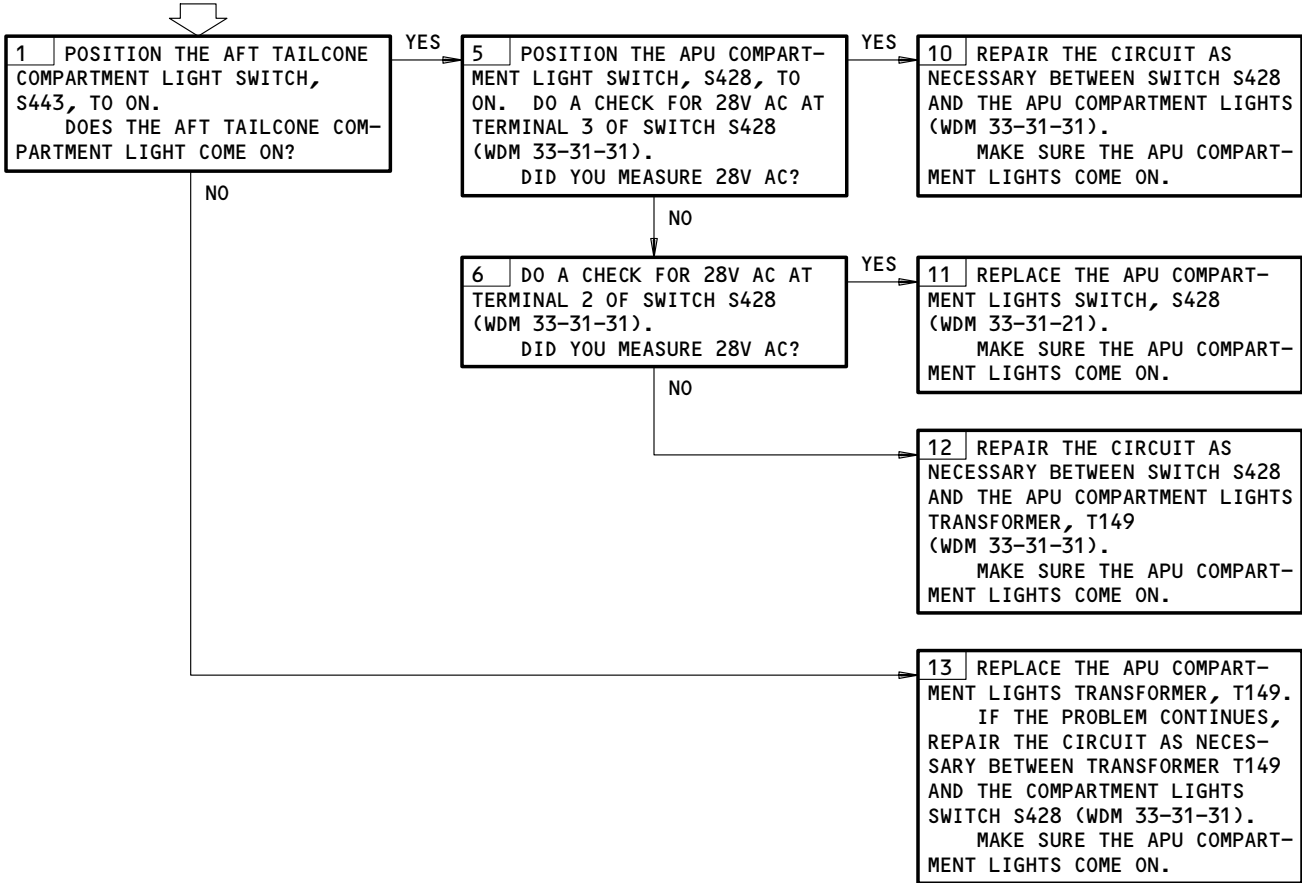

APU Compartment Lights Problems
Figure 107

EFFECTIVITY	ALL
-------------	-----

33-31-00

TAILCONE COMPARTMENT LIGHTS PROBLEMS

PREREQUISITES
MAKE SURE THIS CIRCUIT BREAKER IS CLOSED:
34S3

MAKE SURE THE AIRPLANE IS IN THE CONFIGURATION THAT FOLLOWS:
ELECTRICAL POWER IS ON (MM 24-22-00/201)

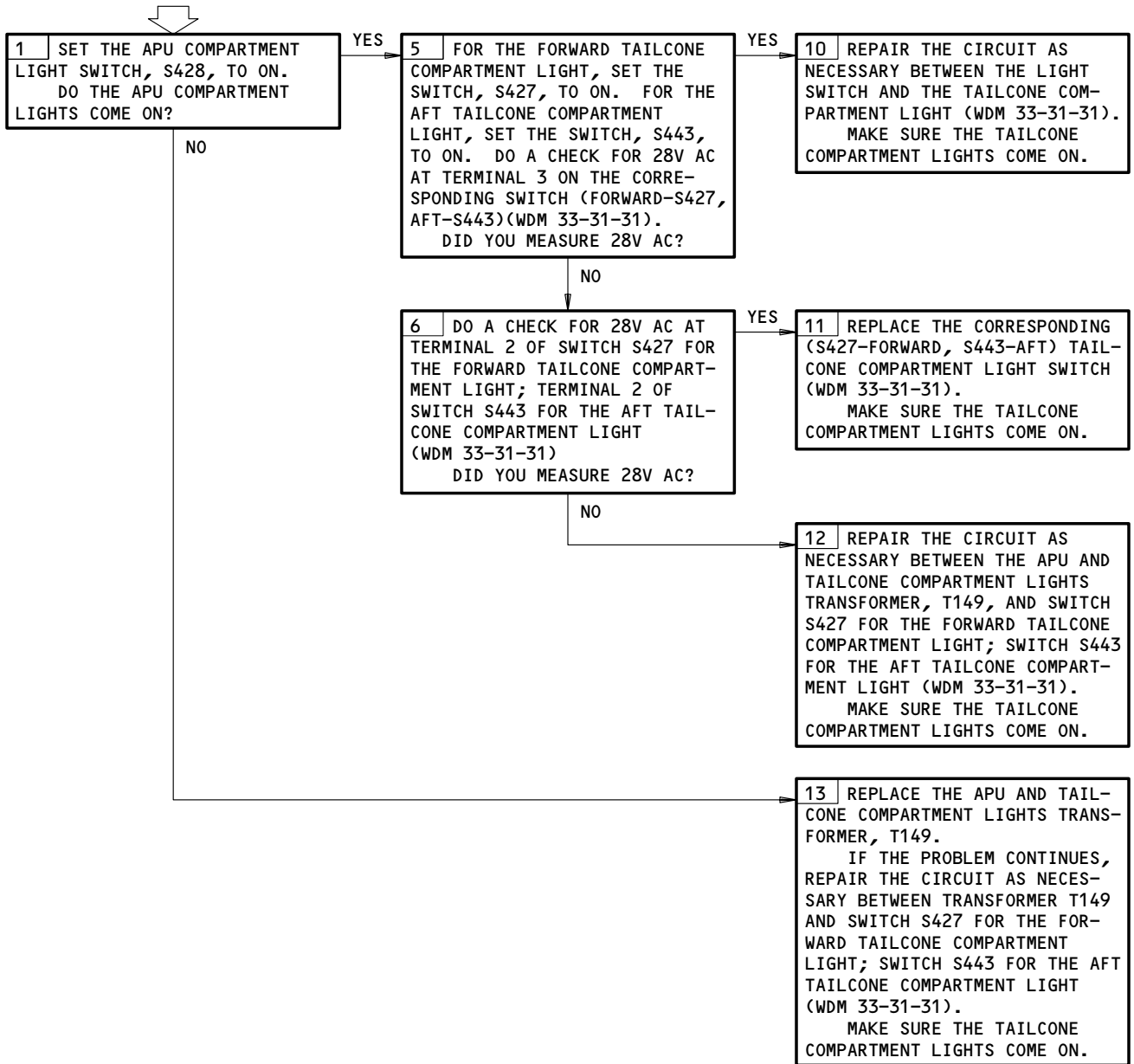

Tailcone Compartment Lights Problems
Figure 108

EFFECTIVITY	ALL
-------------	-----

33-31-00

FORWARD EQUIPMENT CENTER LIGHTS PROBLEMS

PREREQUISITES
 MAKE SURE THIS CIRCUIT BREAKER IS CLOSED:
 33K6
 MAKE SURE THE AIRPLANE IS IN THE CONFIGURATION THAT FOLLOWS:
 ELECTRICAL POWER IS ON (MM 24-22-00/201)

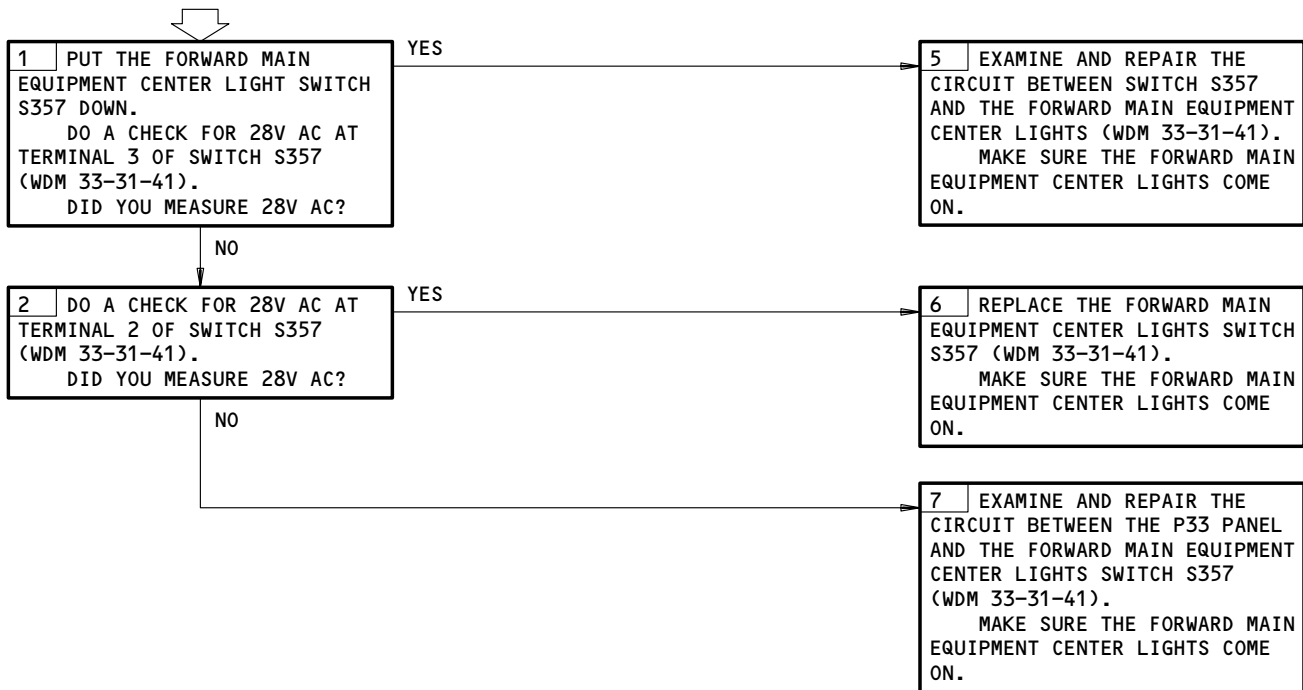

Forward Equipment Center Lights Problems
Figure 109

EFFECTIVITY	ALL
-------------	-----

33-31-00

**MAIN EQUIPMENT
CENTER LIGHTS
PROBLEMS**

PREREQUISITES

MAKE SURE THIS CIRCUIT BREAKER IS CLOSED:
33K6

MAKE SURE THE AIRPLANE IS IN THE CONFIGURATION THAT
FOLLOWS:
ELECTRICAL POWER IS ON (MM 24-22-00/201)

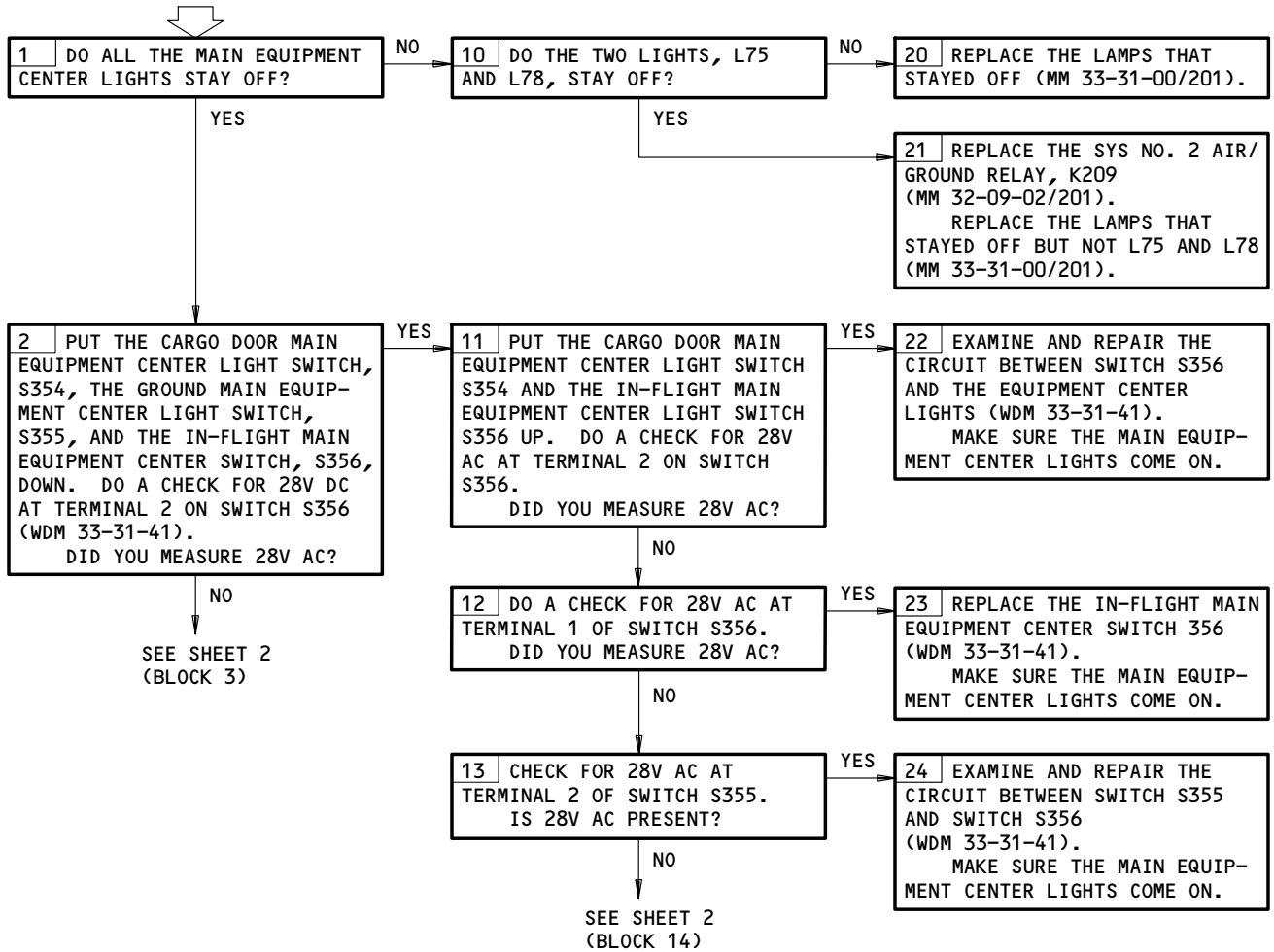

Main Equipment Center Lights Problems
Figure 110 (Sheet 1)

EFFECTIVITY

ALL

33-31-00

02

Page 117
May 10/94

183576

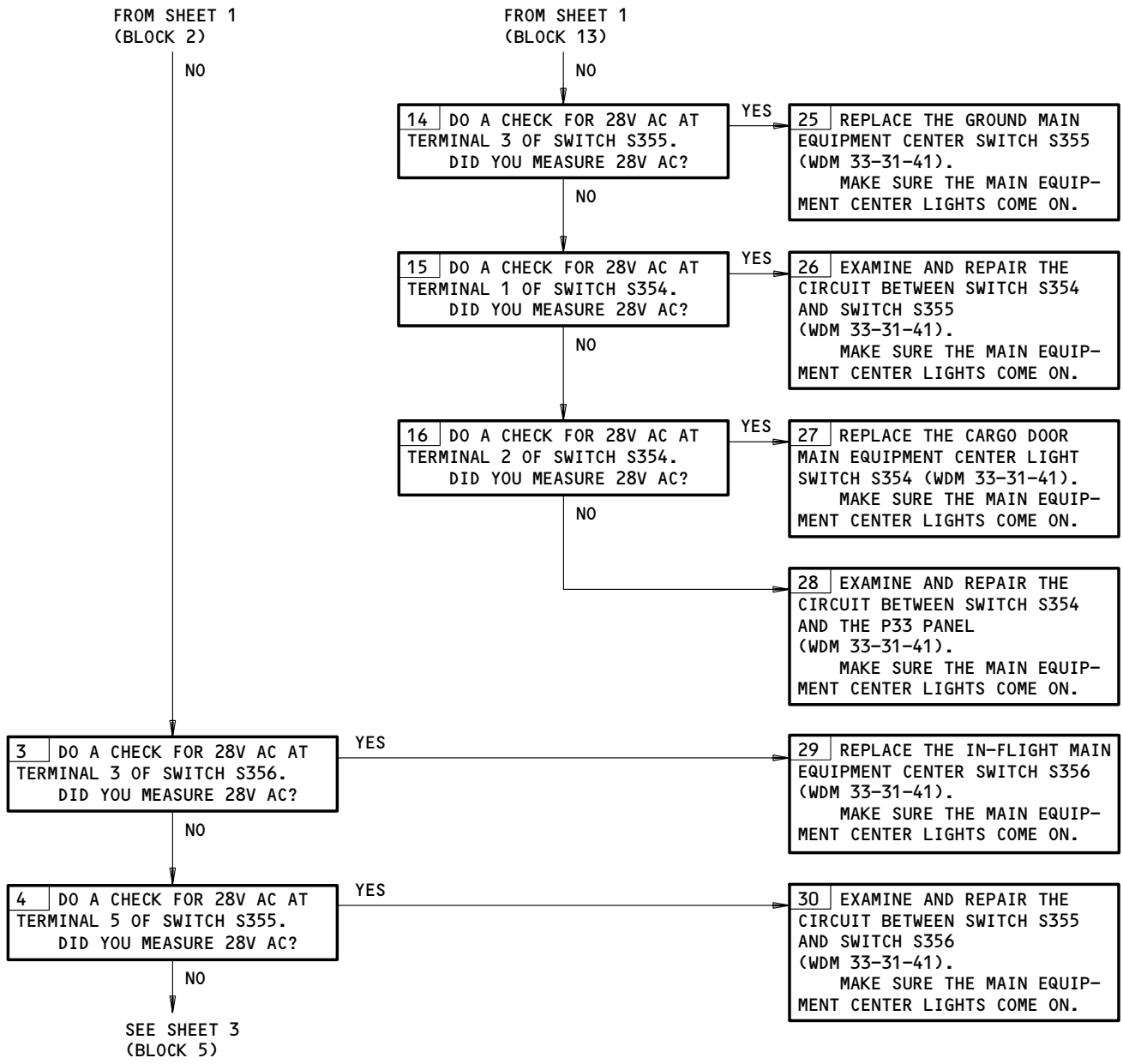

Main Equipment Center Lights Problems
Figure 110 (Sheet 2)

EFFECTIVITY

ALL

33-31-00

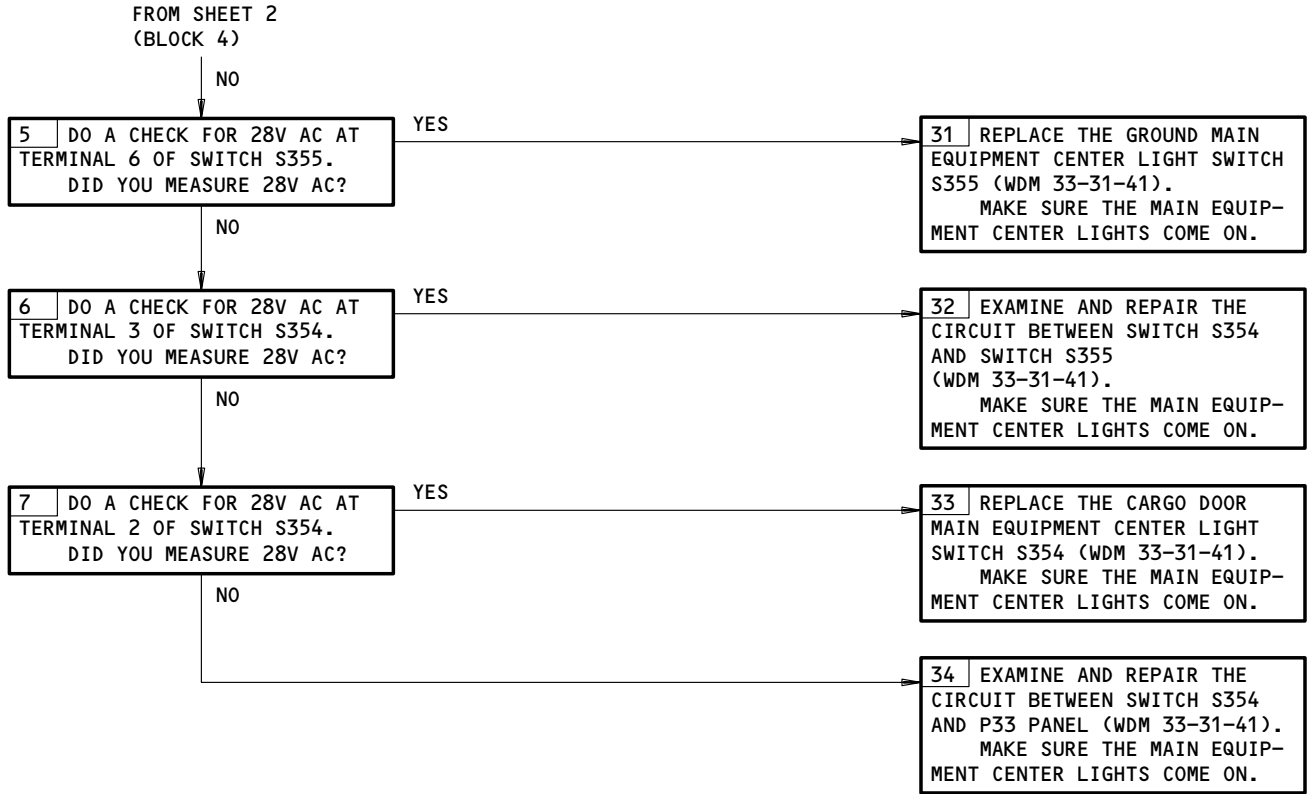

Main Equipment Center Lights Problems
Figure 110 (Sheet 3)

EFFECTIVITY

ALL

33-31-00

**FORWARD CARGO DOOR
EXTERIOR LIGHTS
PROBLEMS**

PREREQUISITES
 MAKE SURE EACH APPLICABLE CIRCUIT BREAKER IS CLOSED:
 (SSM 33-31-04 OR WDM 33-31-61)
 MAKE SURE THE AIRPLANE IS IN THIS CONFIGURATION:
 ELECTRICAL POWER IS ON (AMM 24-22-00/201)

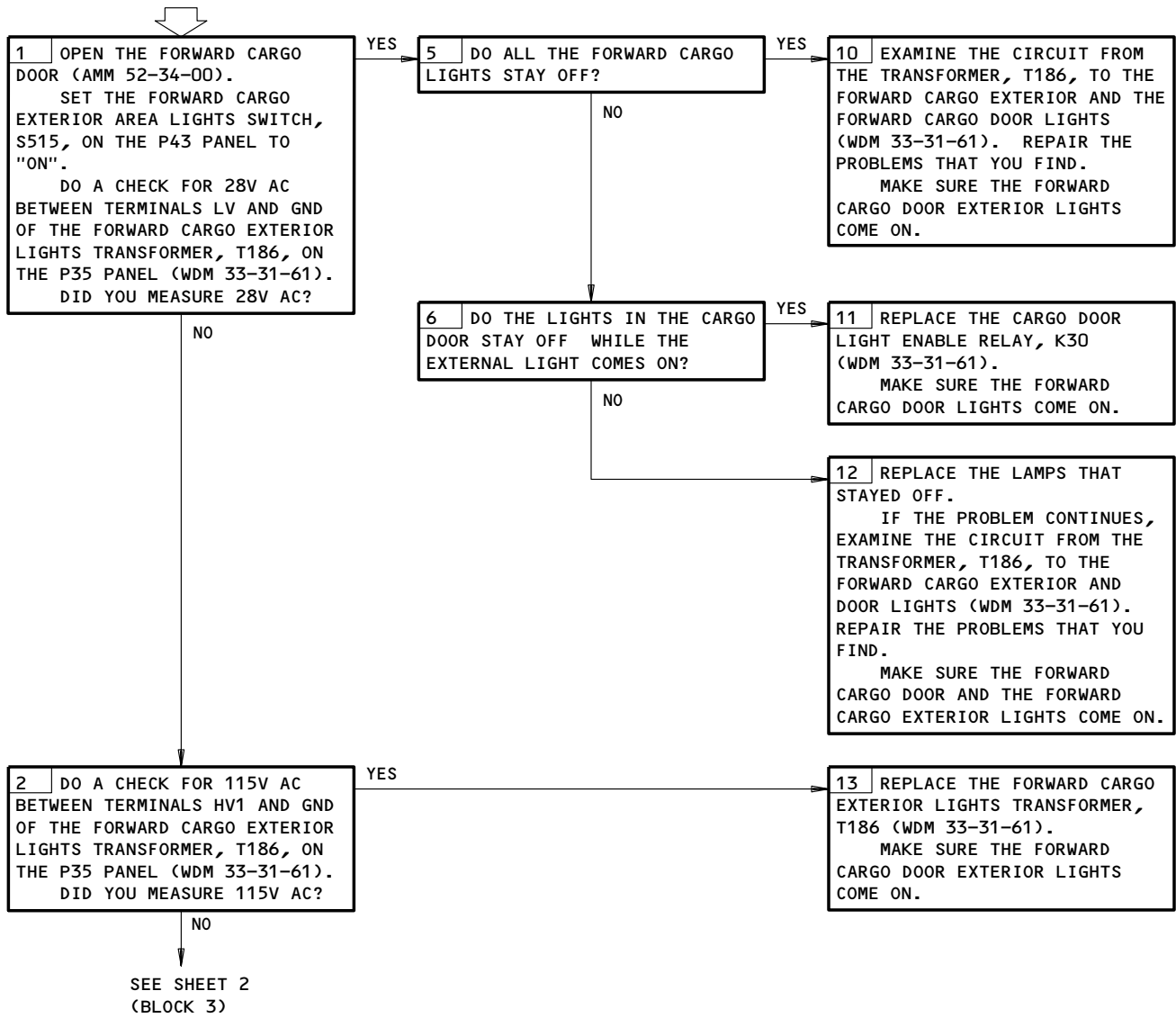

Forward Cargo Door Exterior Lights Problems
Figure 111 (Sheet 1)

EFFECTIVITY
 AIRPLANES WITH EXTERIOR CARGO LOADING
 LIGHTS

33-31-00

A32263

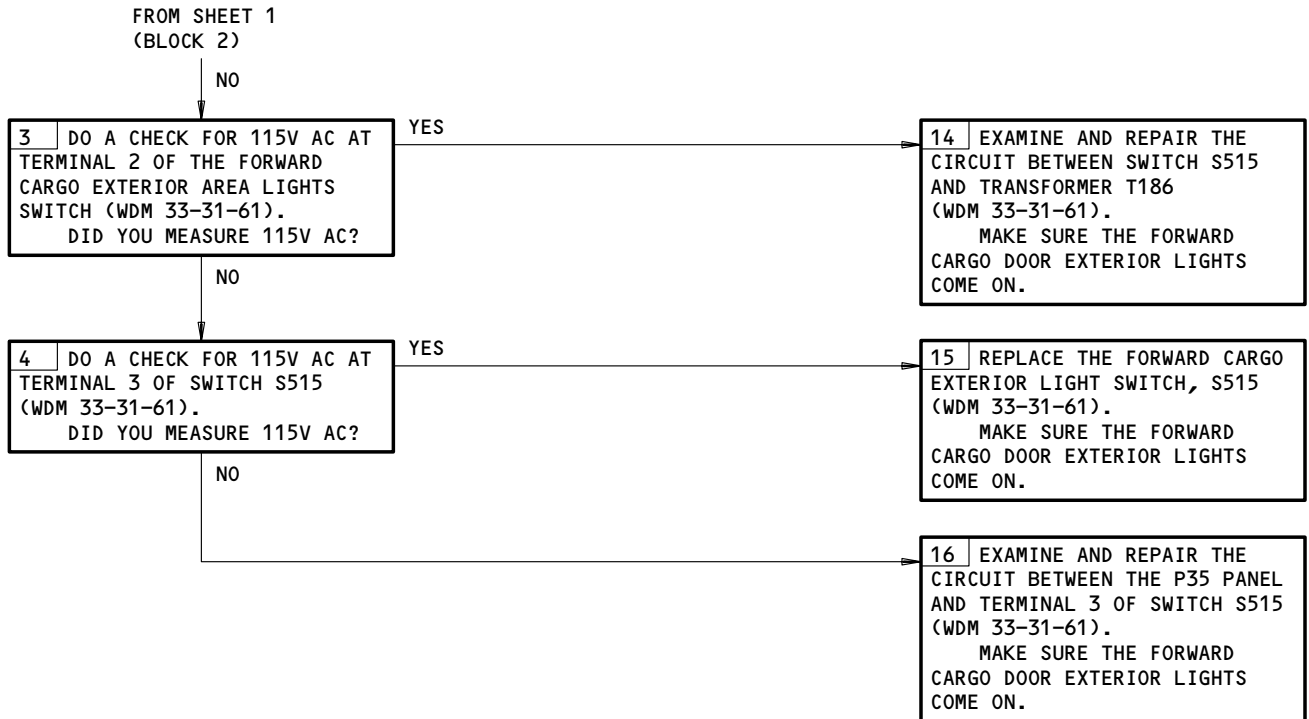

Forward Cargo Door Exterior Lights Problems
Figure 111 (Sheet 2)

EFFECTIVITY
AIRPLANES WITH EXTERIOR CARGO LOADING
LIGHTS

33-31-00

BOEING
767
FAULT ISOLATION/MAINT MANUAL

LOWER LOBE CARGO COMPARTMENT LIGHTS

COMPONENT*	FIG. 102 SHT	QTY *	ACCESS/AREA	AMM REFERENCE
CIRCUIT BREAKER -			119AL, MAIN EQUIP CTR, P34,P37, E1-2	*
CIRCUIT BREAKER -			821 (822), FWD (AFT) CARGO COMPT, P35 (P39)	*
LIGHT -				
AFT CARGO COMPT	4	*	822, AFT CARGO COMPT	*
FWD CARGO COMPT	1	*	821, FWD CARGO COMPT	*
SWITCH -				
BULK CARGO COMPT LIGHTS	1,3	*	811, BULK CARGO COMPT DOORWAY	*
EXT AFT AND FWD CARGO COMPT LIGHTS	3	1	BELOW AFT AND FWD CARGO DOOR P44, P43	*
INT AFT AND FWD CARGO COMPT LIGHTS	1,2	*	821 (822), FWD (AFT) CARGO COMPT, P35 (P39)	*
RELAY -		*	821 (822), FWD (AFT) CARGO COMPT, P35 (P39)	*
TRANSFORMER -		*	821 (822), FWD (AFT) CARGO COMPT, P35 (P39)	*

* SEE THE SSM OR WDM FOR THE EQUIPMENT NUMBER, QUANTITY AND LOCATION OF EACH COMPONENT IN THE LIGHTING CIRCUIT.

Lower Lobe Cargo Compartment Lights - Component Index
Figure 101

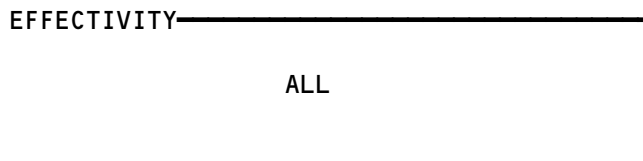

33-37-00

01

Page 101
May 10/94

61961

BOEING
767
FAULT ISOLATION/MAINT MANUAL

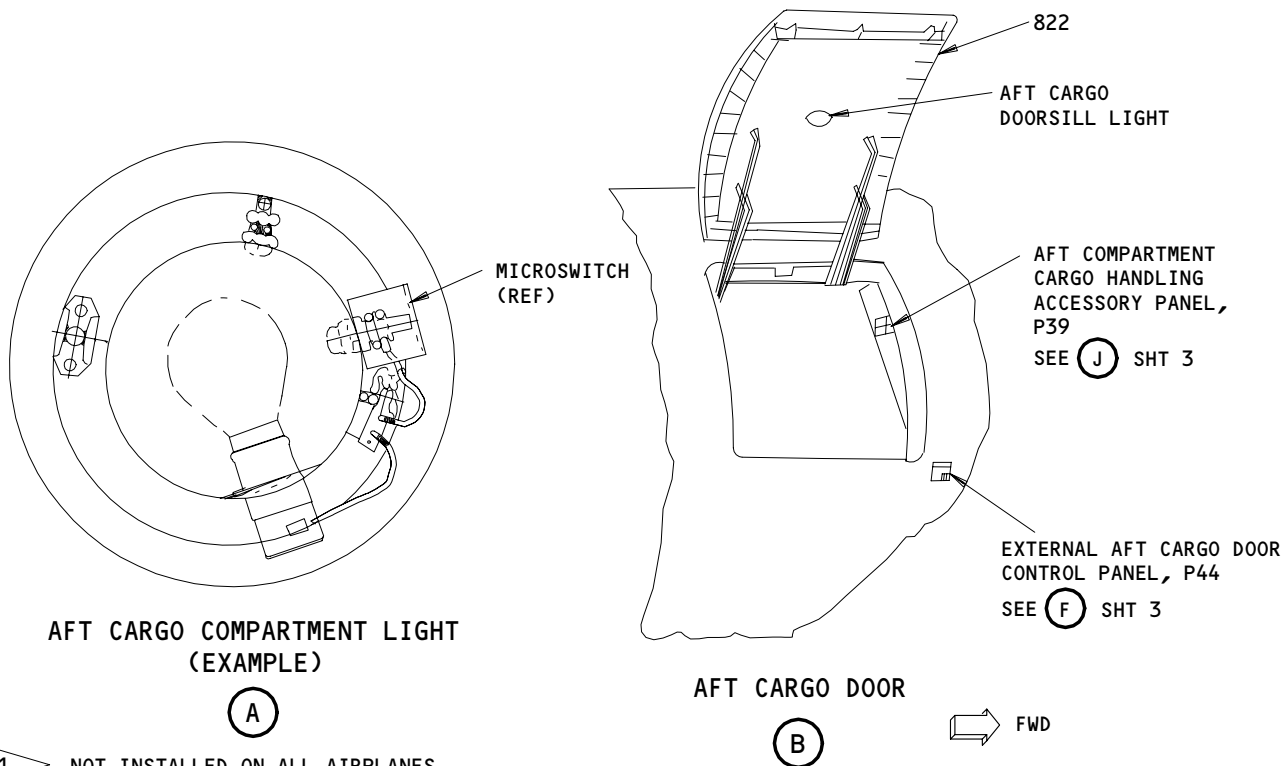
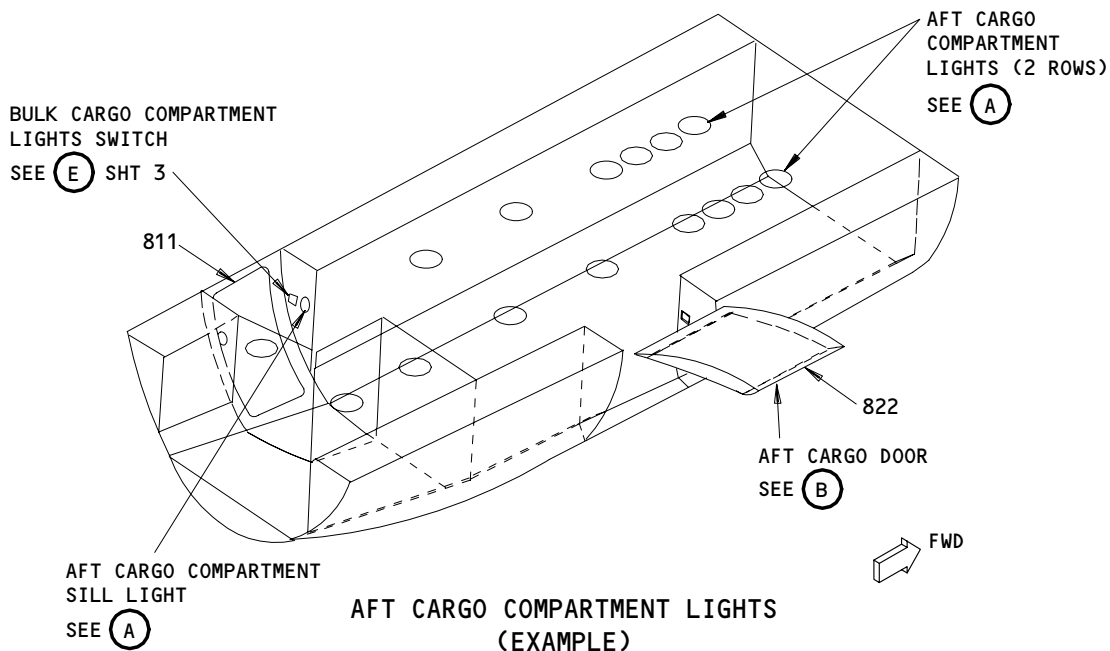

1 NOT INSTALLED ON ALL AIRPLANES

Lower Lobe Cargo Compartment Lights - Component Location
Figure 102 (Sheet 1)

EFFECTIVITY	ALL
-------------	-----

33-37-00

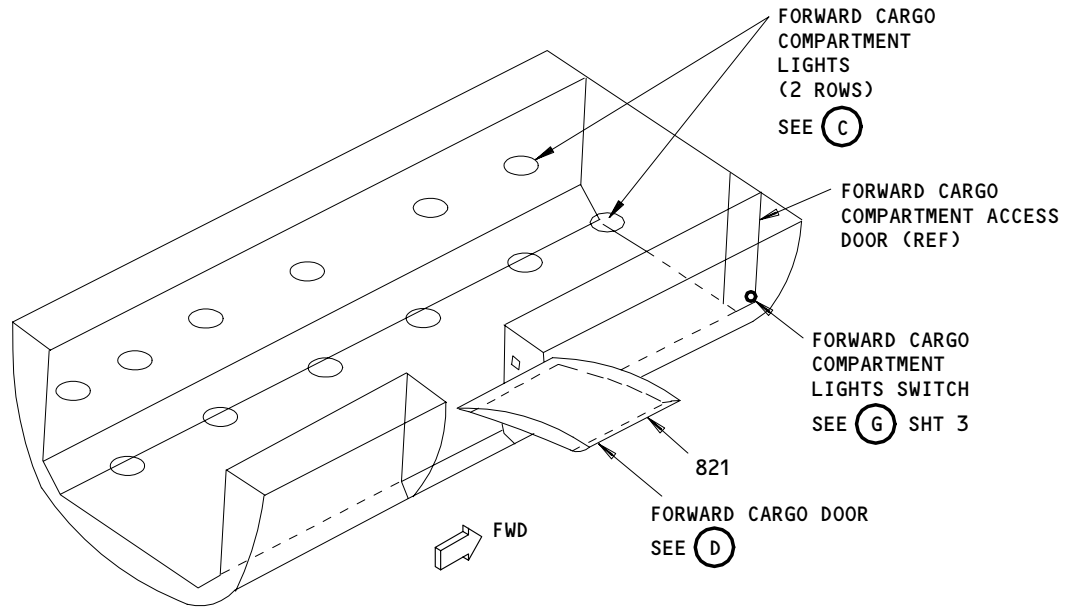

**FORWARD CARGO COMPARTMENT LIGHTS
(EXAMPLE)**

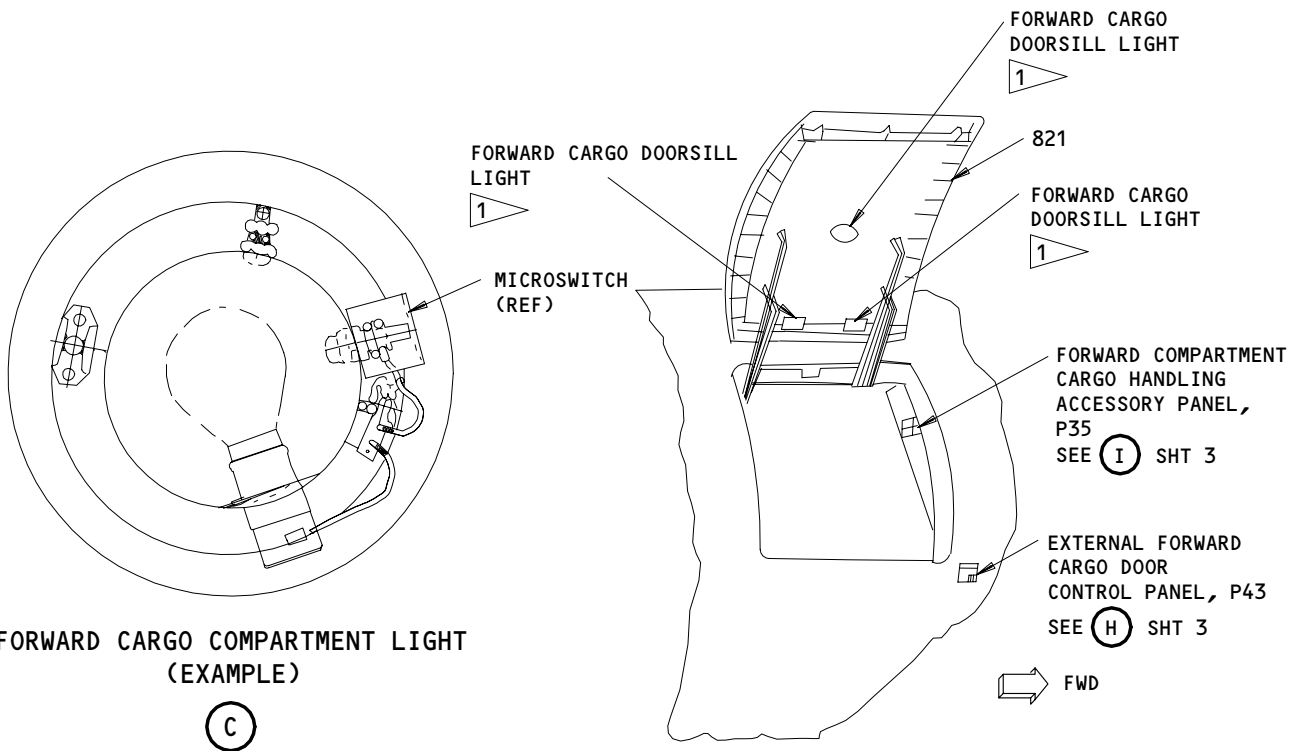

FORWARD CARGO DOOR

(D)

1 NOT INSTALLED ON ALL AIRPLANES

**Lower Lobe Cargo Compartment Lights - Component Location
Figure 102 (Sheet 2)**

EFFECTIVITY	ALL
-------------	-----

33-37-00

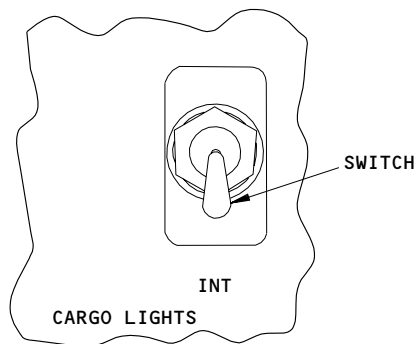

BULK CARGO COMPARTMENT LIGHTS SWITCH

(E) FROM SHT 1

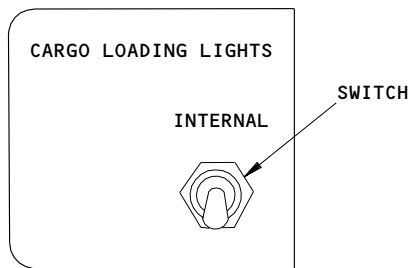

EXTERNAL AFT CARGO DOOR CONTROL PANEL, P44

(F) FROM SHT 1

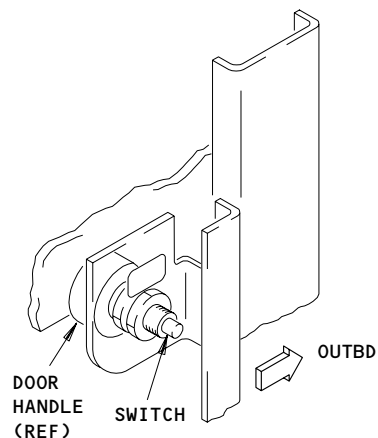

FORWARD CARGO COMPARTMENT LIGHTS SWITCH

(G) FROM SHT 2

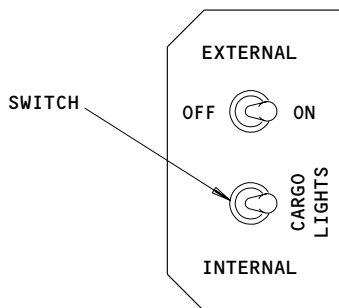

EXTERNAL FORWARD CARGO DOOR CONTROL PANEL, P43

(H) 1 FROM SHT 2

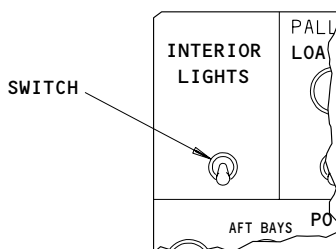
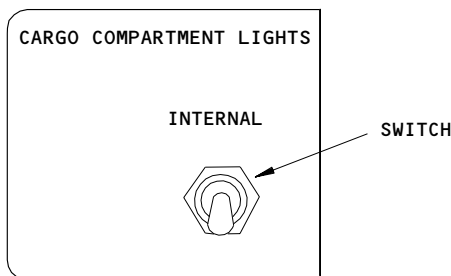

FORWARD COMPARTMENT CARGO HANDLING ACCESSORY PANEL, P35

(I) FROM SHT 2

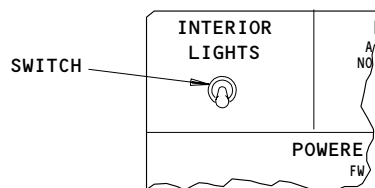

AFT COMPARTMENT CARGO HANDLING ACCESSORY PANEL, P39

(J) FROM SHT 1

**Lower Lobe Cargo Compartment Lights - Component Location
Figure 102 (Sheet 3)**

EFFECTIVITY	ALL
-------------	-----

33-37-00

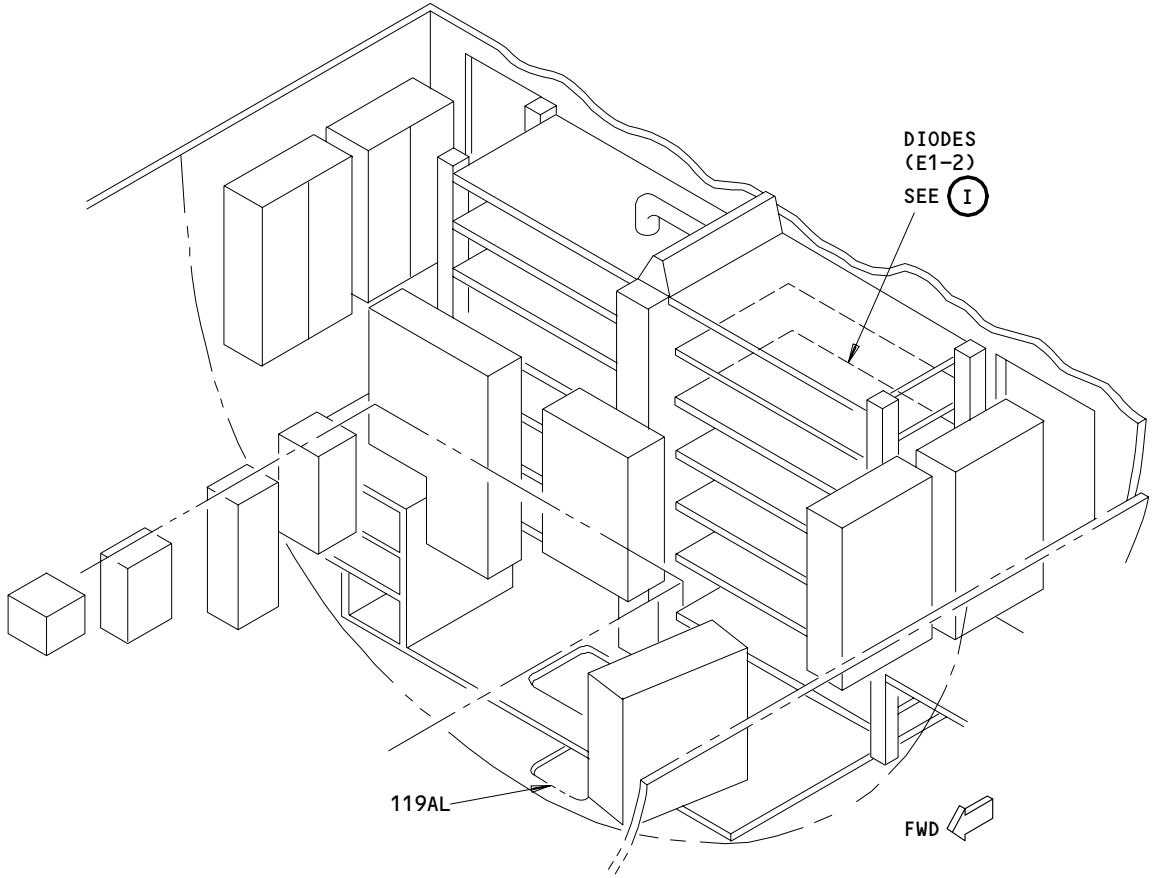

MAIN EQUIPMENT CENTER

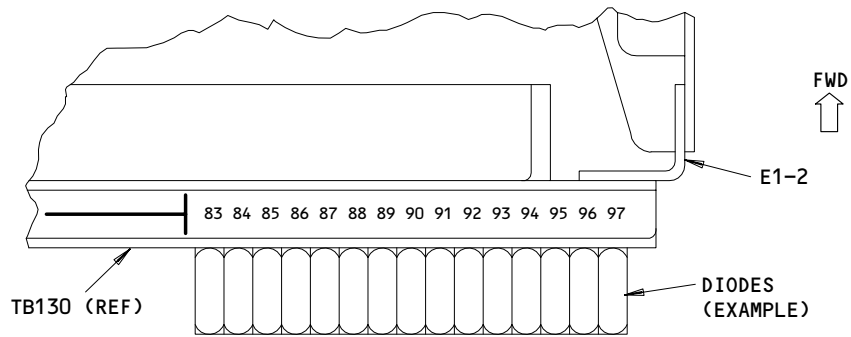

DIODES
(TOP VIEW)

I

Lower Lobe Cargo Compartment Lights - Component Location
Figure 102 (Sheet 4)

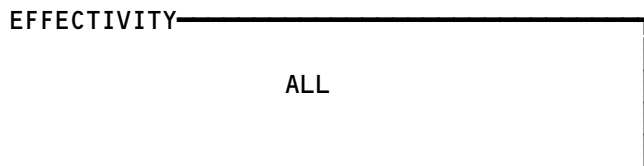

33-37-00

01

Page 105
May 10/94

94501

**FORWARD CARGO
 COMPARTMENT LIGHTS
 "OFF" WITH FORWARD
 CARGO ACCESS DOOR
 OPEN**

PREREQUISITES

MAKE SURE THESE CIRCUIT BREAKERS ARE CLOSED:
 34S10, 35D3, 35D4

MAKE SURE THE AIRPLANE IS IN THIS CONFIGURATION:
 ELECTRICAL POWER IS ON (AMM 24-22-00/201)
 FORWARD CARGO DOOR IS OPEN (AMM 52-34-00/201)

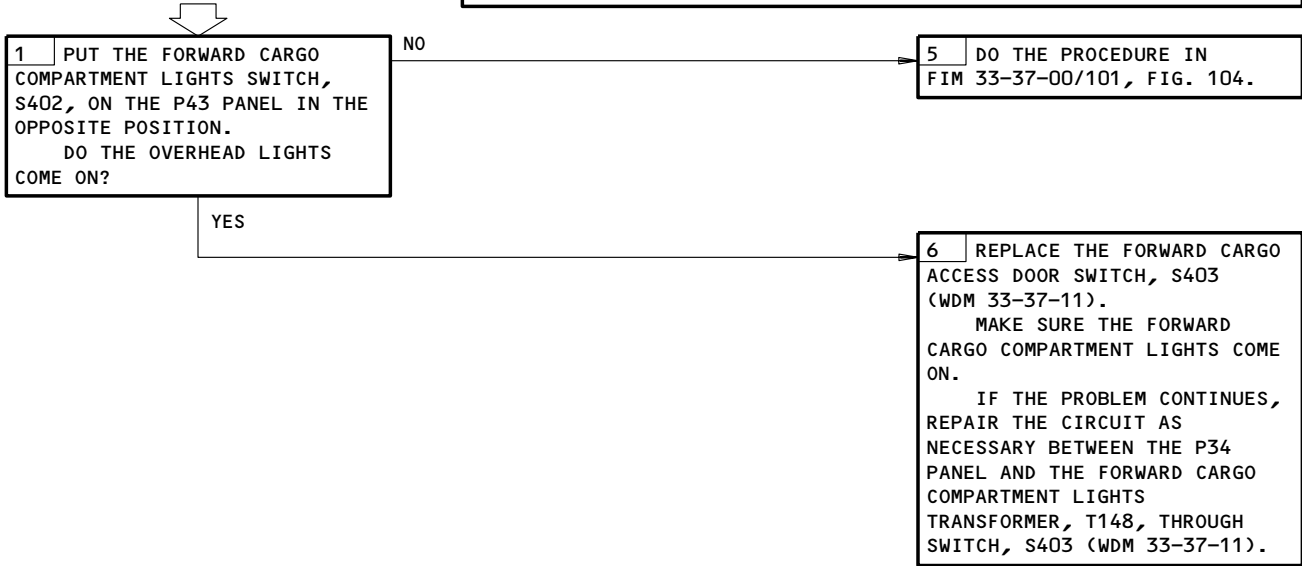

Forward Cargo Compartment Lights OFF with Forward Cargo Access Door Open
 Figure 103

EFFECTIVITY	ALL
-------------	-----

33-37-00

**FORWARD CARGO
COMPARTMENT LIGHT
PROBLEMS**

PREREQUISITES

MAKE SURE THESE CIRCUIT BREAKERS ARE CLOSED:
34S10, 34J2, 35D3, 35D4, 35D5

MAKE SURE THE AIRPLANE IS IN THIS CONFIGURATION:
ELECTRICAL POWER IS ON (AMM 24-22-00/201)
PROXIMITY SWITCH SYSTEM OPERATES (AMM 32-09-03/001)
FORWARD CARGO DOOR IS OPEN (AMM 52-34-00/201)

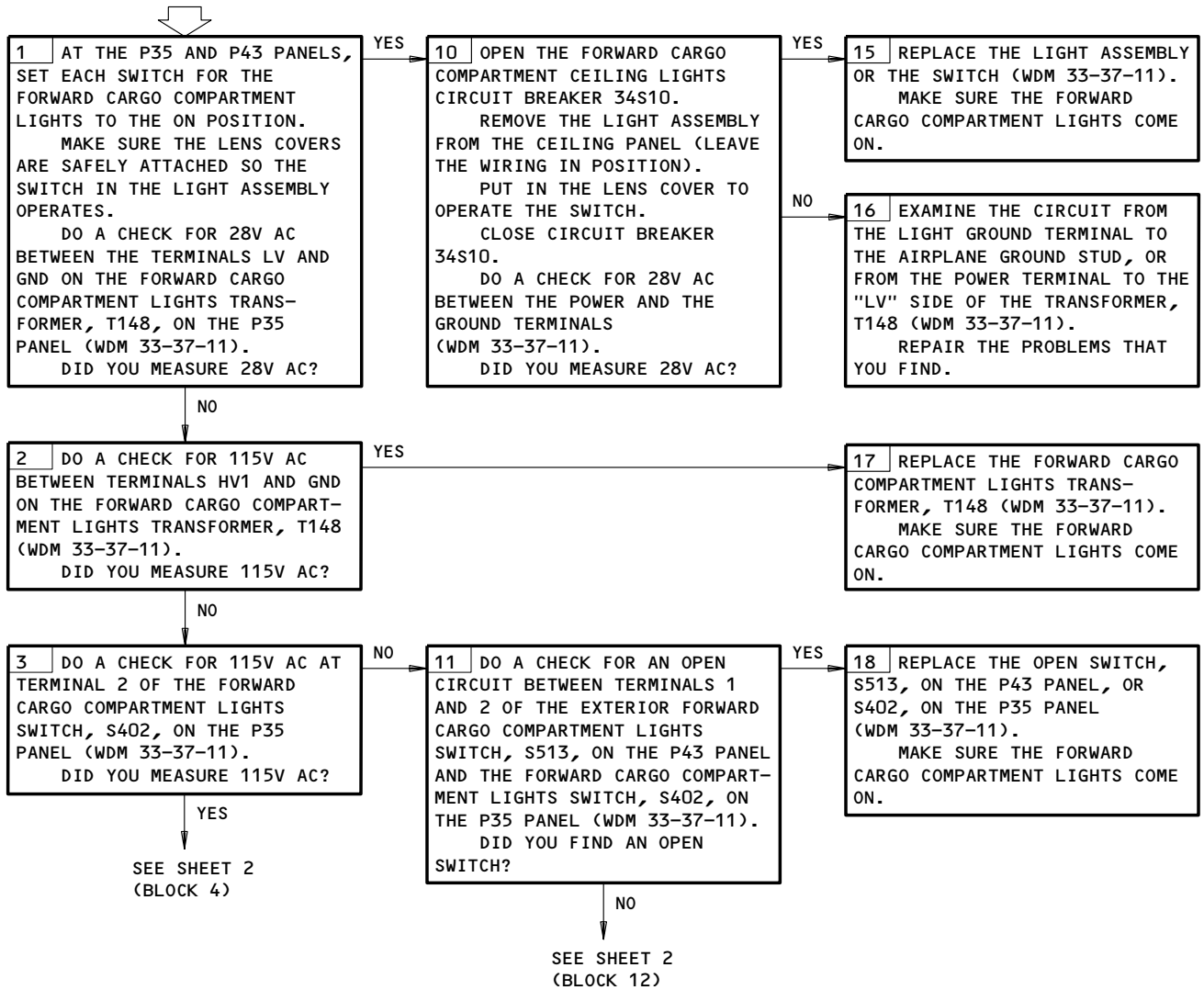

Forward Cargo Compartment Light Problems
Figure 104 (Sheet 1)

EFFECTIVITY

ALL

33-37-00

01

Page 107
Dec 22/99

32531

BOEING
767
FAULT ISOLATION/MAINT MANUAL

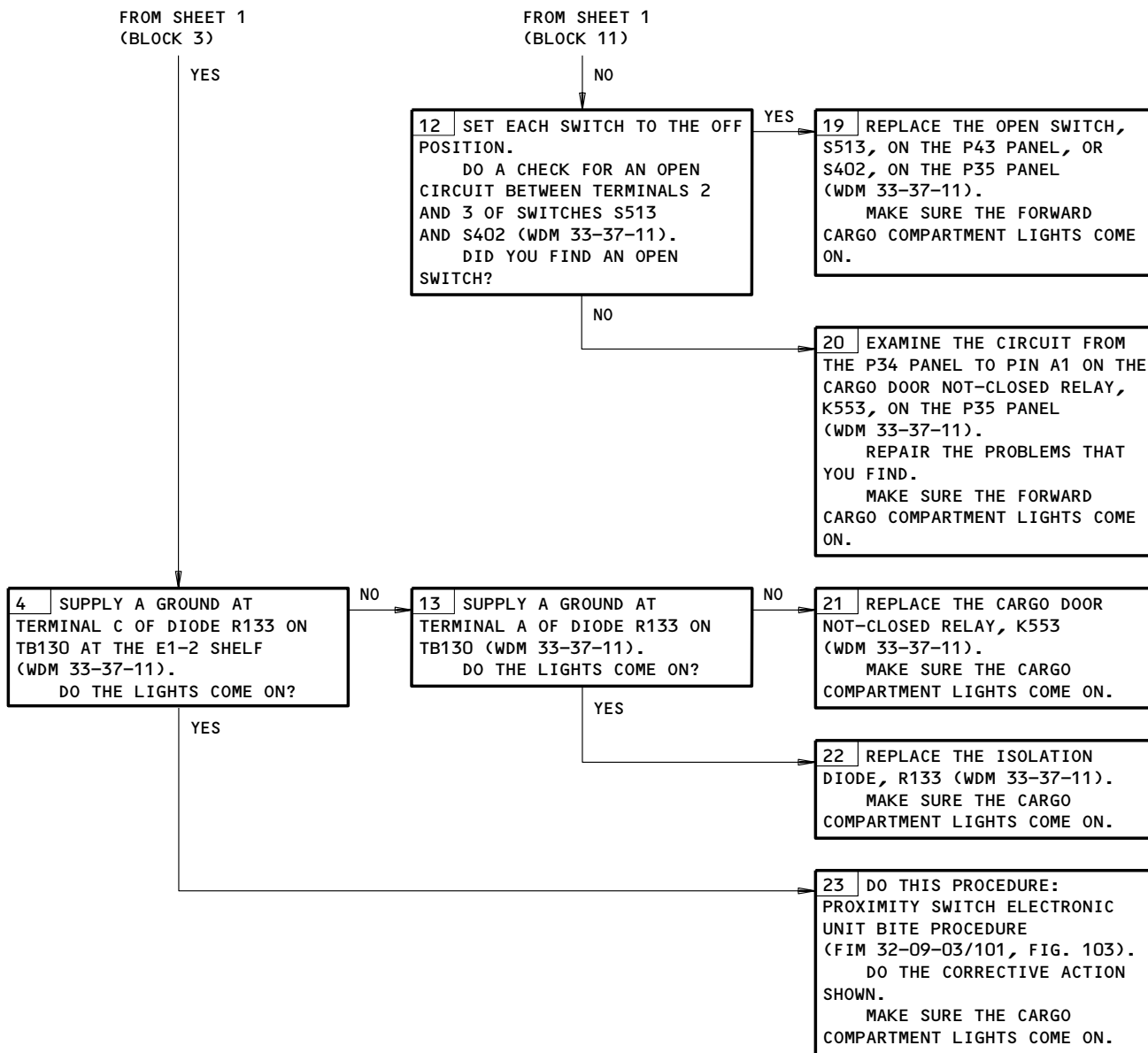

Forward Cargo Compartment Light Problems
Figure 104 (Sheet 2)

EFFECTIVITY

ALL

33-37-00

01

Page 108
Dec 22/99

202115

**AFT CARGO
COMPARTMENT LIGHT
PROBLEMS**

PREREQUISITES

MAKE SURE THESE CIRCUIT BREAKERS ARE CLOSED:
34S11, 34J3, 39D3, 39D4, 39D5

MAKE SURE THE AIRPLANE IS IN THIS CONFIGURATION:
ELECTRICAL POWER IS ON (AMM 24-22-00/201)
AFT CARGO DOOR IS OPEN (AMM 52-35-00/201)
BULK CARGO DOOR IS OPEN (AMM 52-36-00/001)
PROXIMITY SWITCH SYSTEM OPERATES (AMM 32-09-03/001)

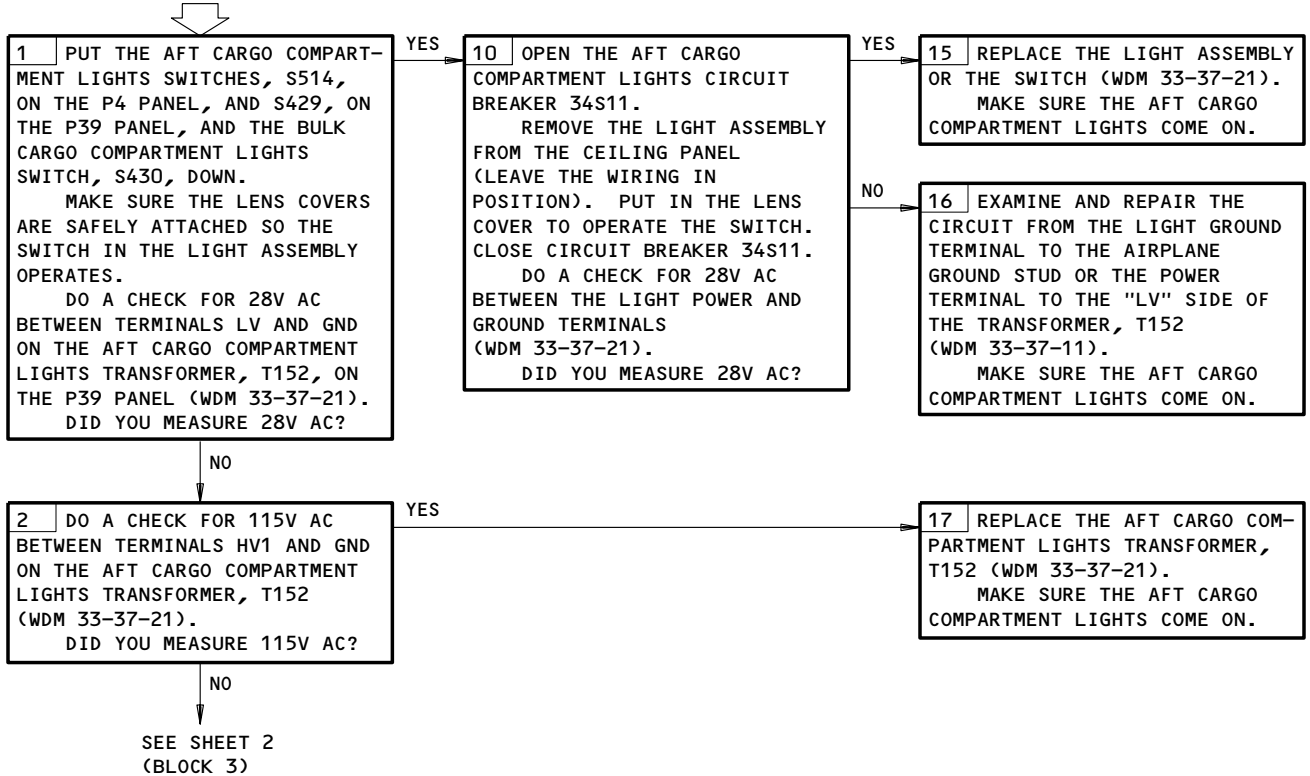

Aft Cargo Compartment Light Problems
Figure 105 (Sheet 1)

EFFECTIVITY

ALL

33-37-00

01

Page 109
Dec 22/99

42971

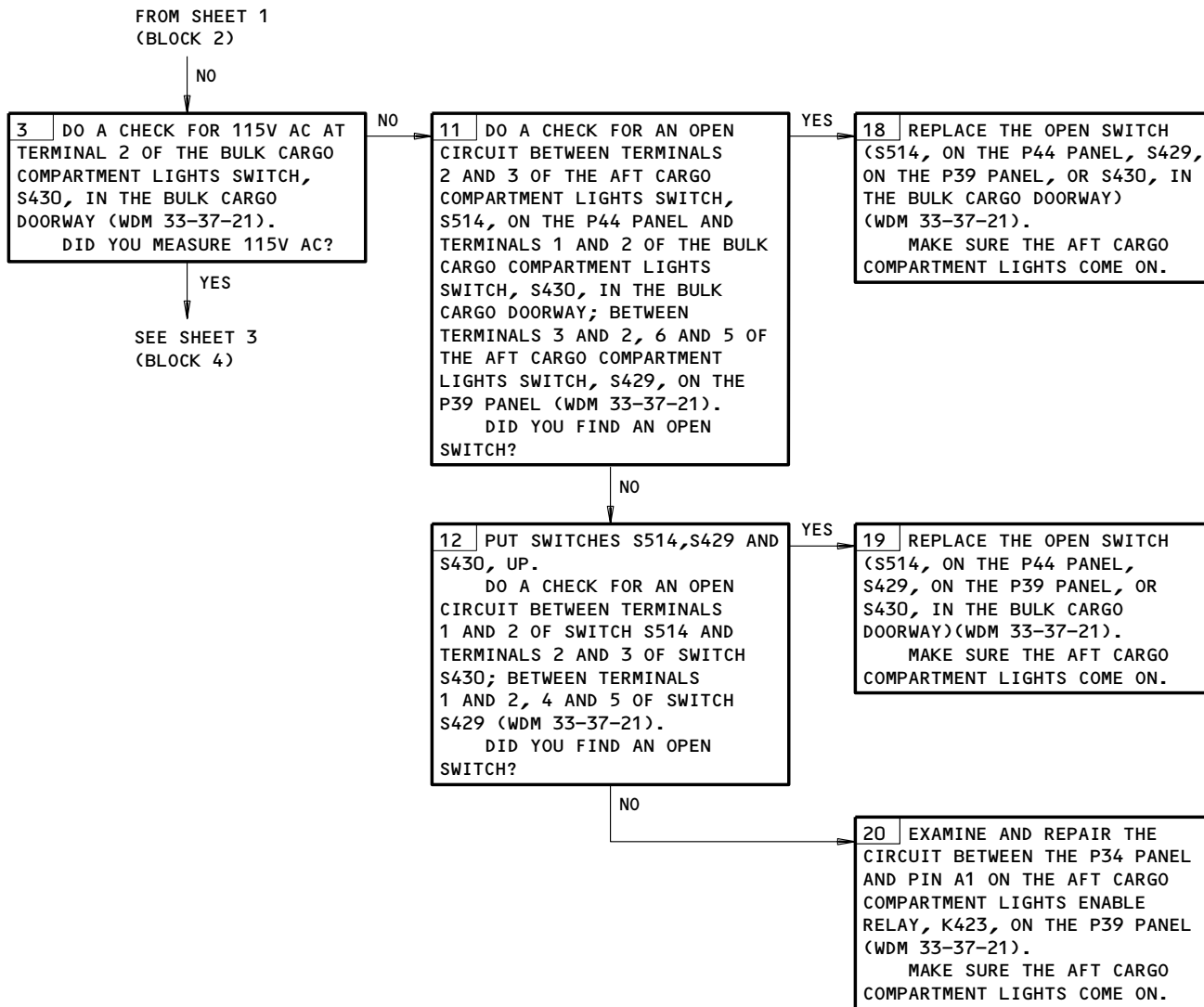

BOEING
 767
 FAULT ISOLATION/MAINT MANUAL



Aft Cargo Compartment Light Problems
Figure 105 (Sheet 2)

EFFECTIVITY	ALL
-------------	-----

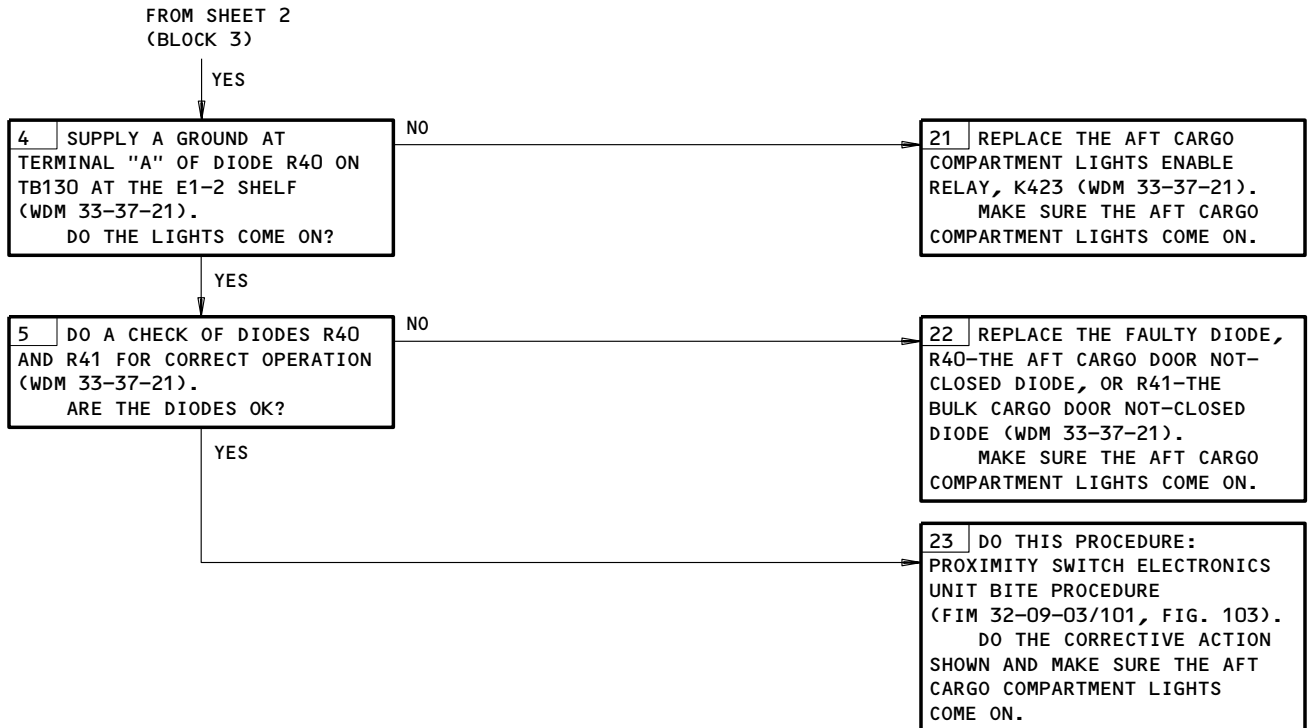
33-37-00



Aft Cargo Compartment Light Problems
Figure 105 (Sheet 3)

EFFECTIVITY

ALL

33-37-00



BOEING
 767
 FAULT ISOLATION/MAINT MANUAL

WING ILLUMINATION LIGHTS

COMPONENT	FIG. 102 SHT	QTY *	ACCESS/AREA	AMM REFERENCE
CIRCUIT BREAKER - LIGHT - WING ILLUMINATION	--	*	FLT COMPT, P11 ON FUSELAGE, FWD, AND ABOVE THE WING	33-41-00
SWITCH - WING ILLUMINATION LIGHT	--	*		FLT COMPT, P5

* SEE THE SSM OR WDM FOR THE EQUIPMENT NUMBER, QUANTITY, AND LOCATION OF EACH COMPONENT IN THE LIGHTING CIRCUIT.

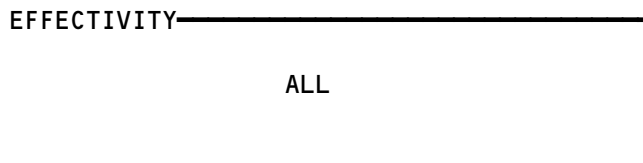
Wing Illumination Lights - Component Index
Figure 101



33-41-00

01

Page 101
Nov 10/94

750839

BOEING
767
FAULT ISOLATION/MAINT MANUAL

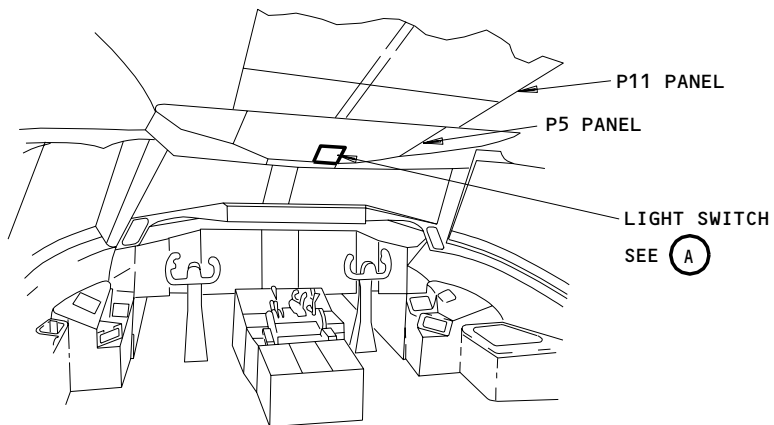

FLIGHT COMPARTMENT

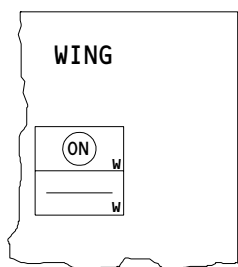
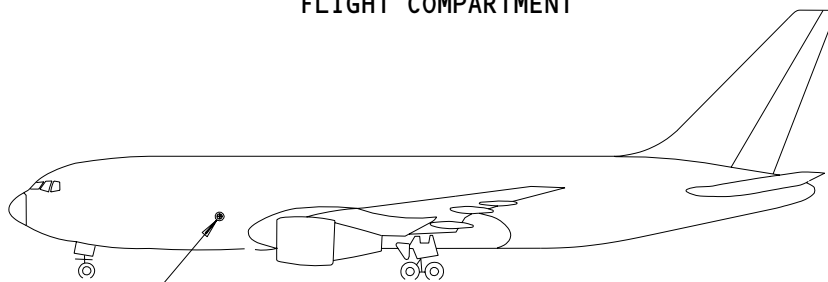

WING ILLUMINATION
LIGHT SWITCH

(A)

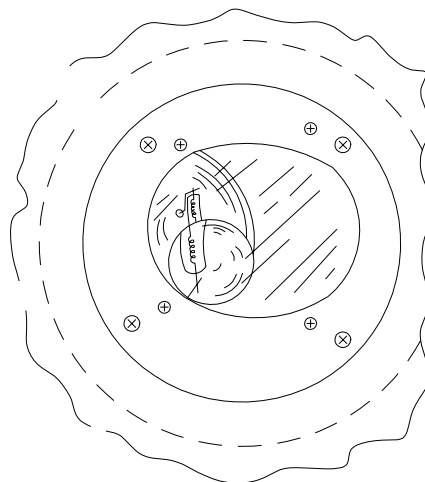

WING ILLUMINATION LIGHT
(EXAMPLE)

(B)

Wing Illumination Lights - Component Location
Figure 102

EFFECTIVITY	ALL
-------------	-----

33-41-00



01

Page 102
May 10/95



767
 FAULT ISOLATION/MAINT MANUAL

LANDING, RUNWAY TURNOFF, AND TAXI LIGHTS

COMPONENT*	FIG. 102 SHT	QTY *	ACCESS/AREA	AMM REFERENCE
CIRCUIT BREAKER -	1		FLT COMPT, P11	*
LIGHT -	2	*	LEADING EDGE OF EACH WING ROOT	33-42-03
WING LANDING	2	*	NOSE LANDING GEAR, ABOVE WHEEL 3	33-42-01
NOSE GEAR LANDING	2	*	LEADING EDGE OF EACH WING ROOT	33-42-03
RUNWAY TURNOFF	2	*	NOSE LANDING GEAR, BETWEEN WHEELS	33-42-02
TAXI 			119AL, MAIN EQ CTR, P36,P37	
RELAY -				
SWITCH -				
LANDING GEAR LEVER	1	*	FLT COMPT, P3	*
LANDING NOSE GEAR	1	*	FLT COMPT, P5	*
LANDING WING L AND R	1	*	FLT COMPT, P5	*
RUNWAY TURNOFF L AND R	1	*	FLT COMPT, P5	*
TAXI 	1	*	FLT COMPT, P5	*
TRANSFORMER -	---	*		*

* SEE THE SSM OR WDM FOR THE EQUIPMENT NUMBER, QUANTITY AND LOCATION OF EACH COMPONENT IN THE LIGHTING CIRCUIT.

 NOT INSTALLED ON ALL AIRPLANES

Landing, Runway Turnoff, and Taxi Lights - Component Index
 Figure 101

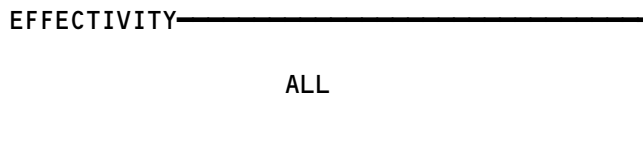

33-42-00

01

Page 101
 May 10/94

977459

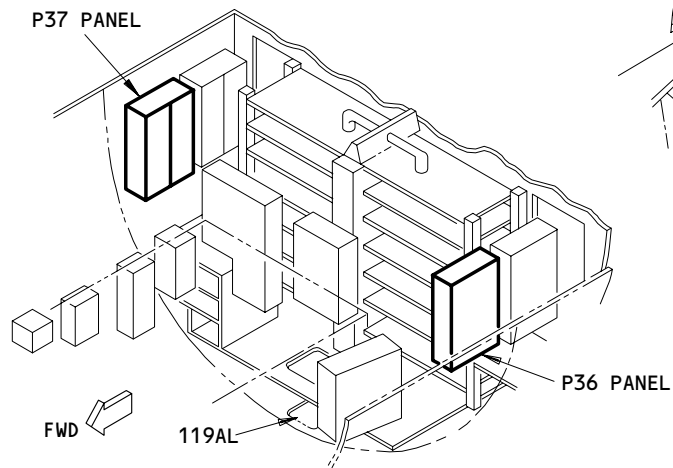
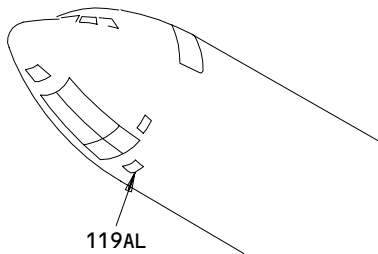

MAIN EQUIPMENT CENTER

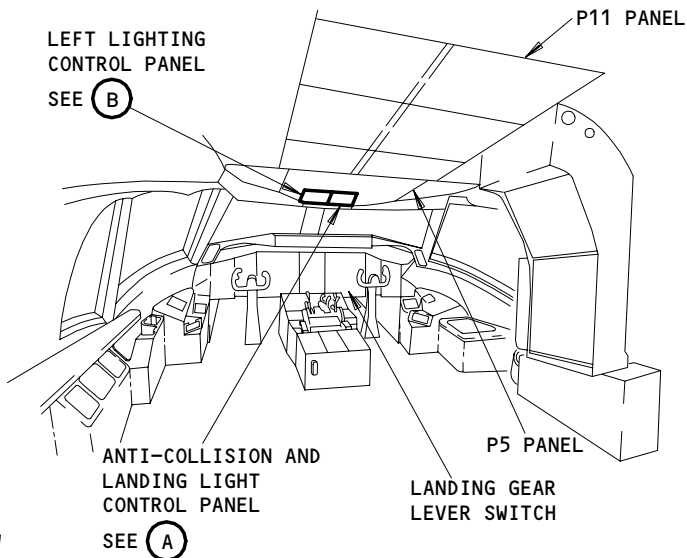

FLIGHT COMPARTMENT

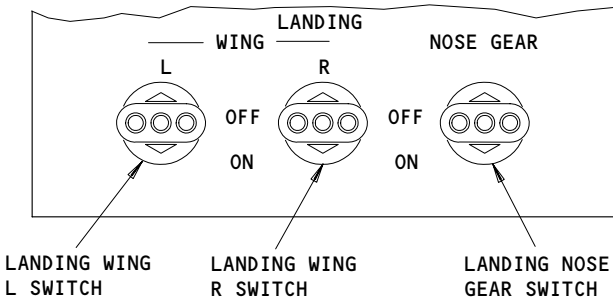

ANTI-COLLISION AND LANDING LIGHT CONTROL PANEL

(A)

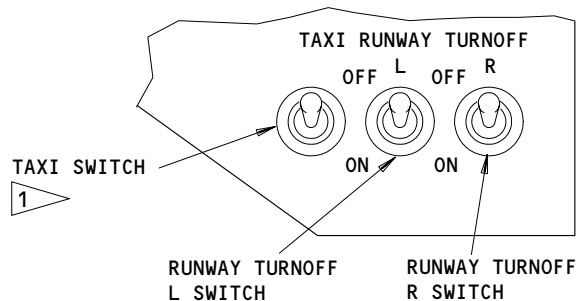

LEFT LIGHTING CONTROL PANEL

(B)

1 NOT INSTALLED ON ALL AIRPLANES

Landing, Runway Turnoff, and Taxi Lights - Component Location
Figure 102 (Sheet 1)

EFFECTIVITY

ALL

33-42-00

01

Page 102
May 10/94

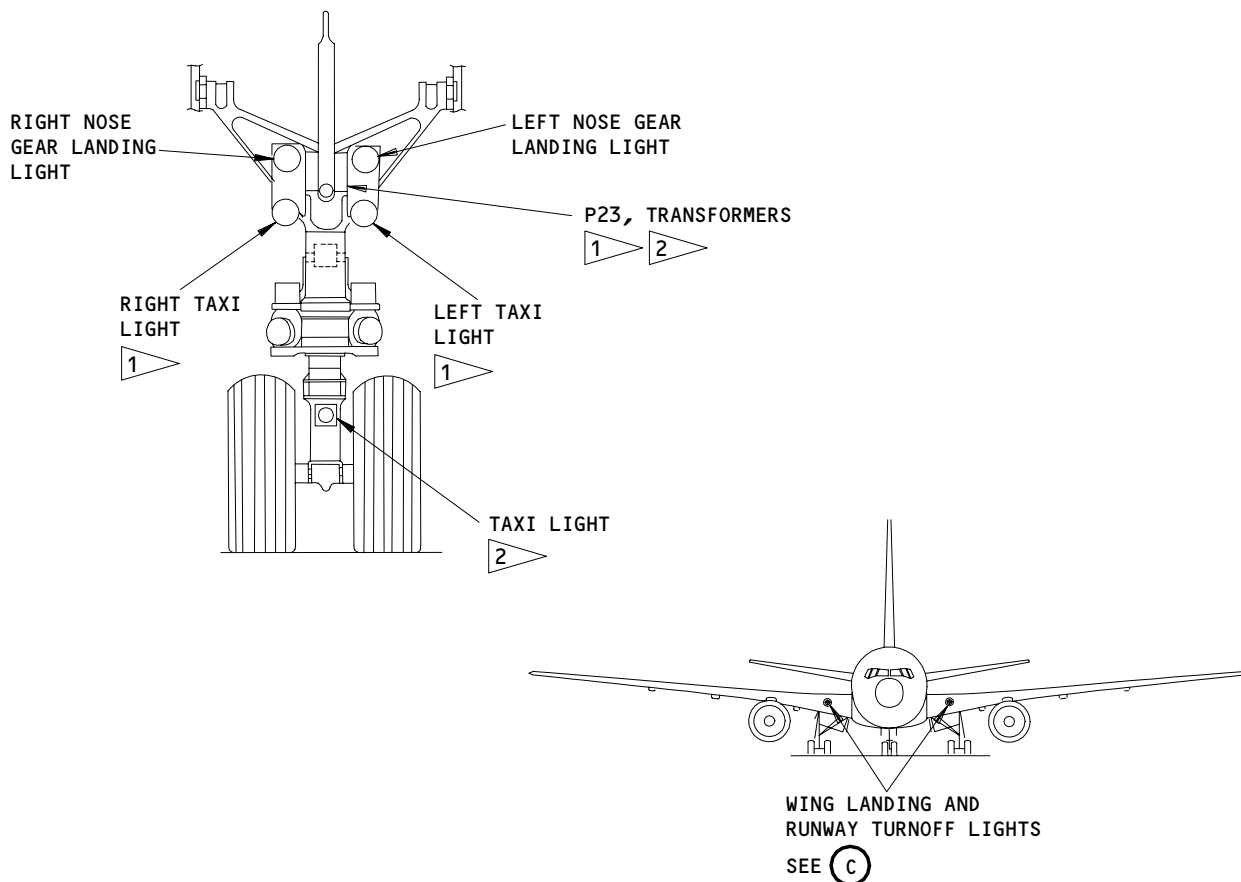

**WING LANDING AND RUNWAY TURNOFF LIGHTS
(EXAMPLE)**

- 1 AIRPLANES WITH TWO TAXI LIGHTS
- 2 AIRPLANES WITH ONE TAXI LIGHT
- 3 ON SOME AIRPLANES, THE TRANSFORMERS ARE INSTALLED IN THE MAIN EQUIPMENT CENTER, P36.

(C)

**Landing, Runway Turnoff, and Taxi Lights - Component Location
Figure 102 (Sheet 2)**

EFFECTIVITY	ALL
-------------	-----

33-42-00

PREREQUISITES

MAKE SURE THE SE CIRCUIT BREAKERS ARE CLOSED:
11N1, 11N8, 11N9

MAKE SURE THE AIRPLANE IS IN THIS CONFIGURATION:
ELECTRICAL POWER IS ON (AMM 24-22-00/201)

TAXI LIGHT PROBLEMS

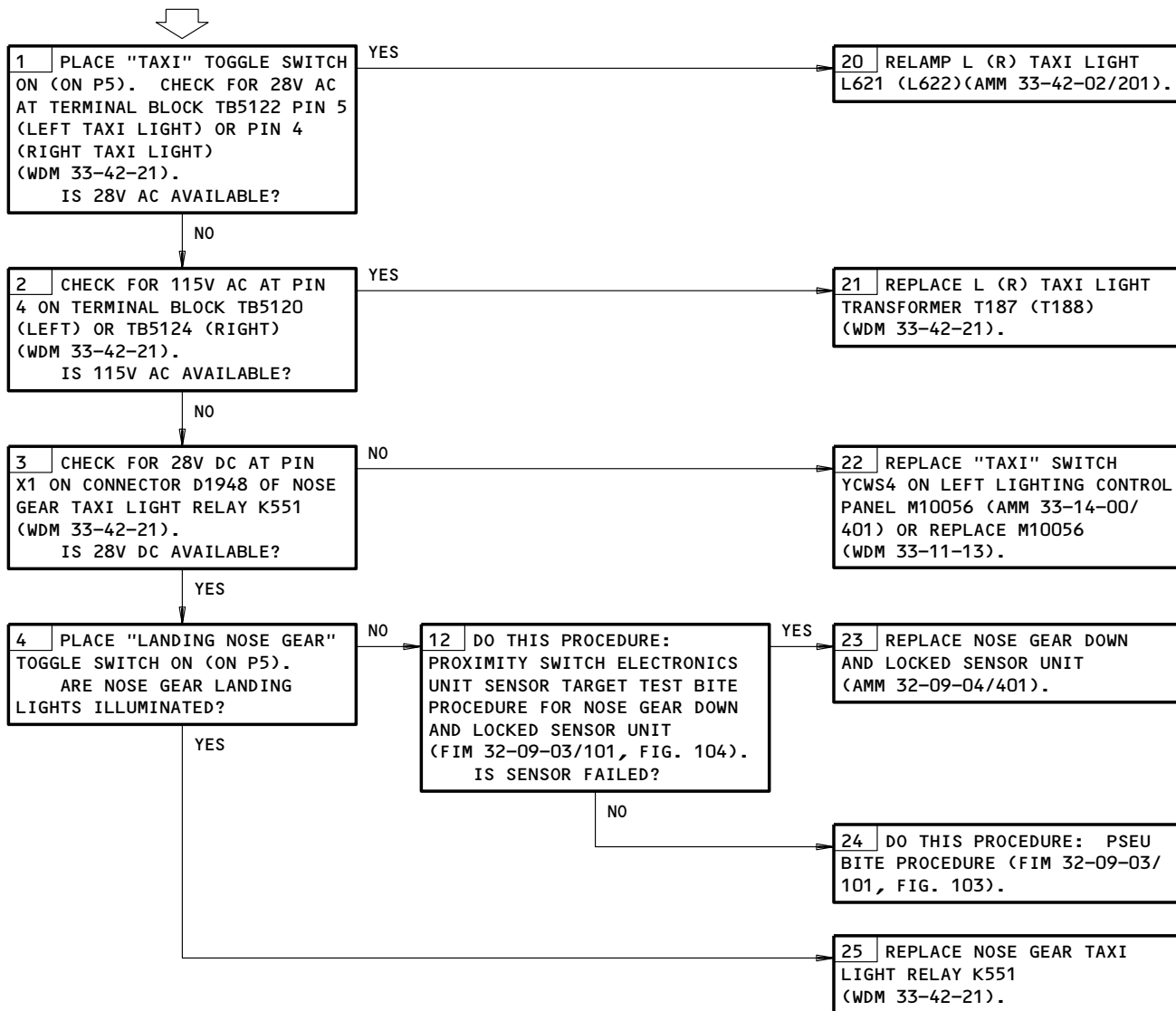

Taxi Light Problems
Figure 103 (Sheet 1)

EFFECTIVITY
AIRPLANES WITH TWO TAXI LIGHTS

33-42-00

TAXI LIGHT PROBLEMS

PREREQUISITES

MAKE SURE THESE CIRCUIT BREAKERS ARE CLOSED:
11N1, 11N8

MAKE SURE THE AIRPLANE IS IN THIS CONFIGURATION:
ELECTRICAL POWER IS ON (AMM 24-22-00/201)

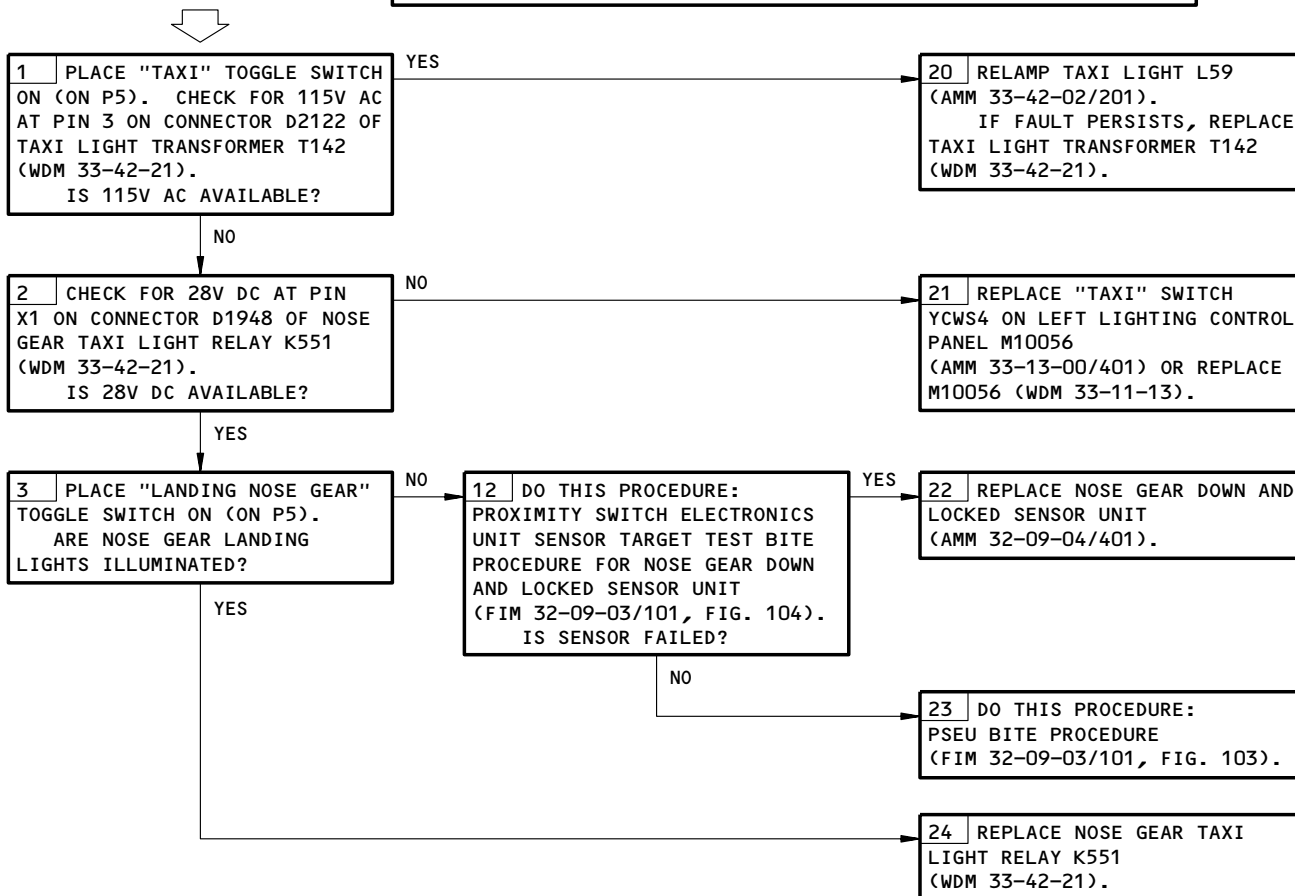

Taxi Light Problems
Figure 103 (Sheet 2)

EFFECTIVITY
AIRPLANES WITH ONE TAXI LIGHT

33-42-00

**RUNWAY TURNOFF
LIGHT PROBLEMS**

PREREQUISITES

MAKE SURE THESE CIRCUIT BREAKERS ARE CLOSED:
11N6, 11N33

MAKE SURE THE AIRPLANE IS IN THIS CONFIGURATION:
ELECTRICAL POWER IS ON (AMM 24-22-00/201)

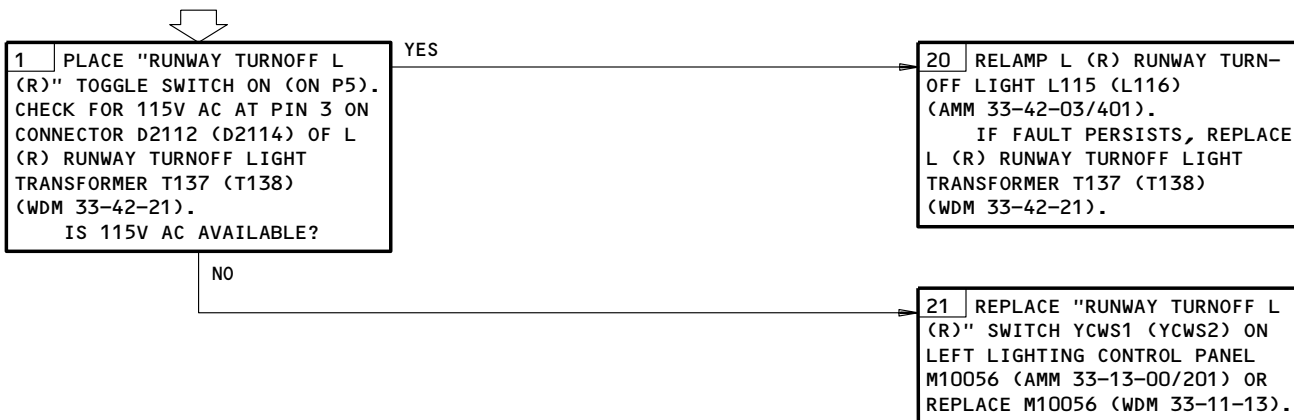

Runway Turnoff Light Problems
Figure 104

EFFECTIVITY

ALL

33-42-00

01

Page 106
Dec 22/99

NOSE GEAR LANDING LIGHT PROBLEMS

PREREQUISITES

MAKE SURE THESE CIRCUIT BREAKERS ARE CLOSED:
11N1, 11N3, 11N4

MAKE SURE THE AIRPLANE IS IN THIS CONFIGURATION:
ELECTRICAL POWER IS ON (AMM 24-22-00/201)

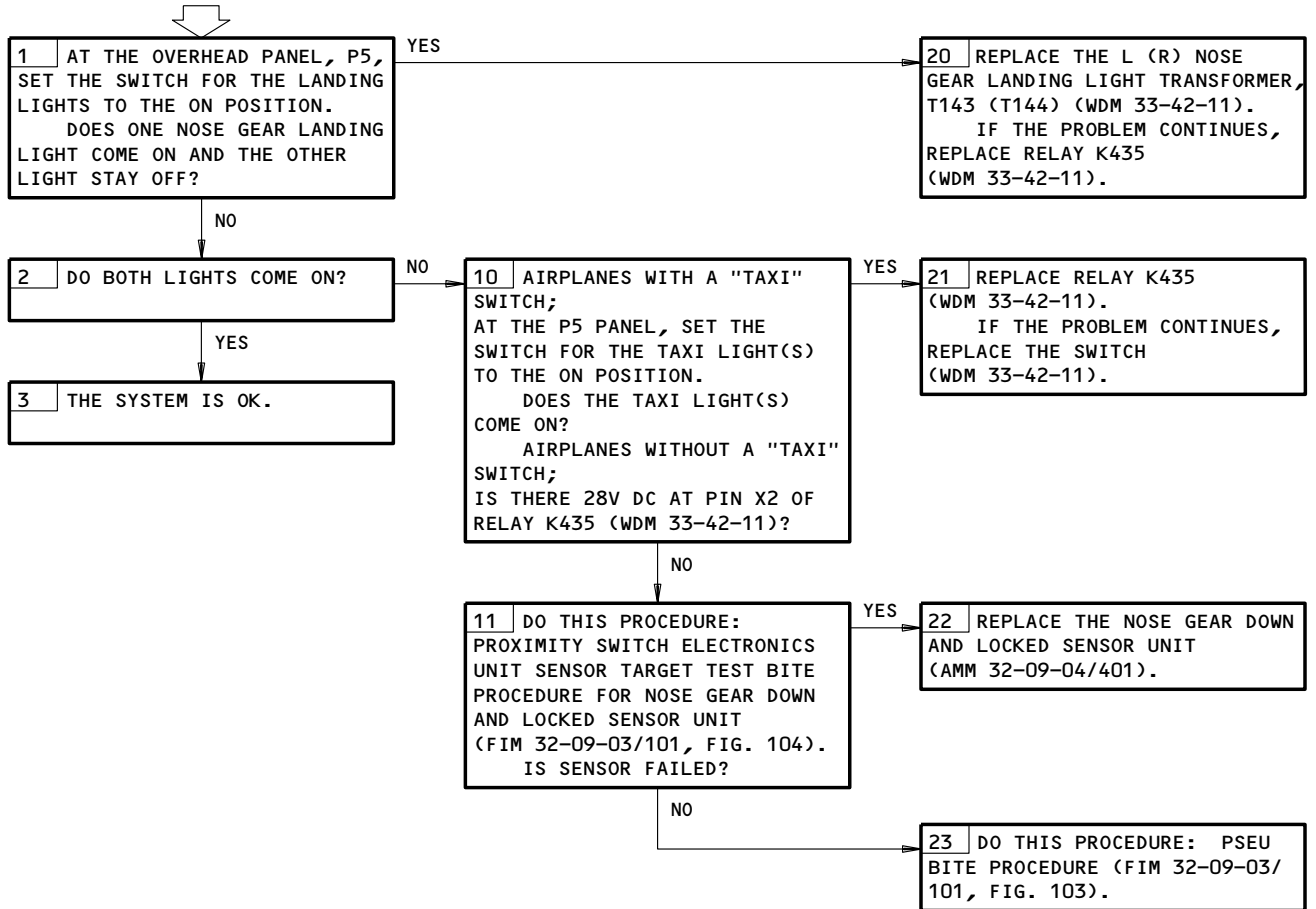

Nose Gear Landing Light Problems
Figure 105

EFFECTIVITY

ALL

33-42-00

03

Page 107
Dec 22/99

949641

WING LANDING LIGHT PROBLEMS
PREREQUISITES

 MAKE SURE THESE CIRCUIT BREAKERS ARE CLOSED:
 11N5, 11N31, 11N32

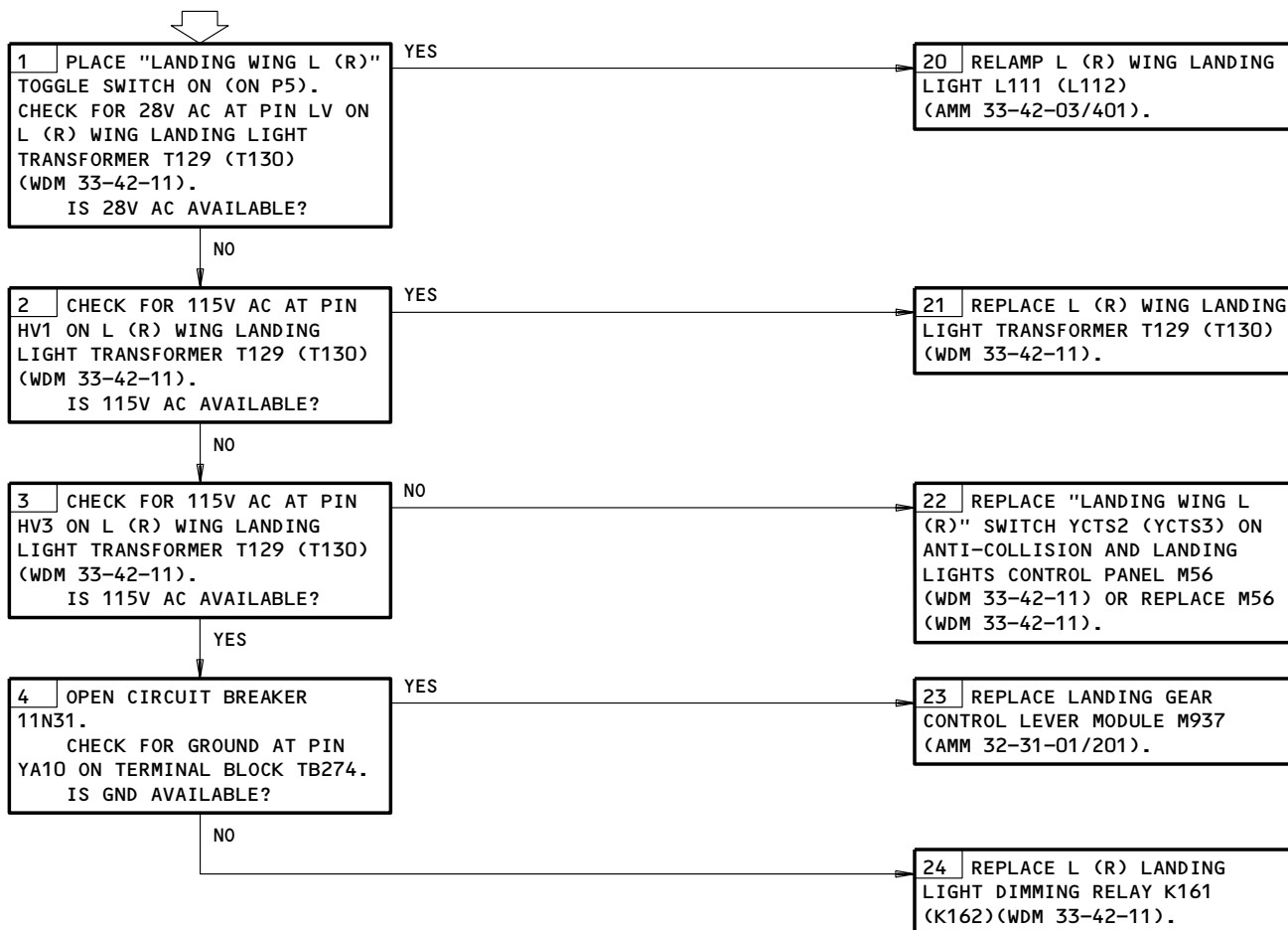
 MAKE SURE THE AIRPLANE IS IN THIS CONFIGURATION:
 ELECTRICAL POWER IS ON (AMM 24-22-00/201)

 Wing Landing Light Problems
 Figure 106

EFFECTIVITY

ALL

33-42-00

03

 Page 108
 Dec 22/99



BOEING
 767
 FAULT ISOLATION/MAINT MANUAL

POSITION LIGHTS

COMPONENT*	FIG. 102	QTY *	ACCESS/AREA	AMM REFERENCE
CIRCUIT BREAKER -	1	*	FLT COMPT, P11	*
LIGHT -				
FWD POSITION	1	*	LEADING EDGE OF THE WINGTIP	33-43-01
REAR POSIITON	2	*	TRAILING EDGE OF THE WINGTIP	33-43-02
SWITCH -	1	*	FLT COMPT, P5	*
TRANSFORMER -	2	*	542B,642B UNDER L AND R WINGTIP	33-43-03

* SEE THE SSM OR WDM FOR THE EQUIPMENT NUMBER, QUANTITY AND LOCATION OF EACH COMPONENT IN THE LIGHTING CIRCUIT.

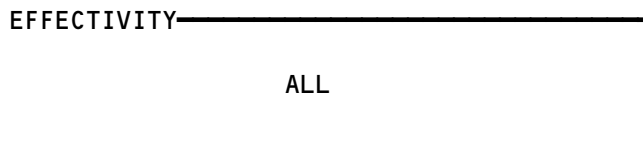
Position Lights - Component Index
Figure 101



33-43-00

01

Page 101
May 10/94

E14219

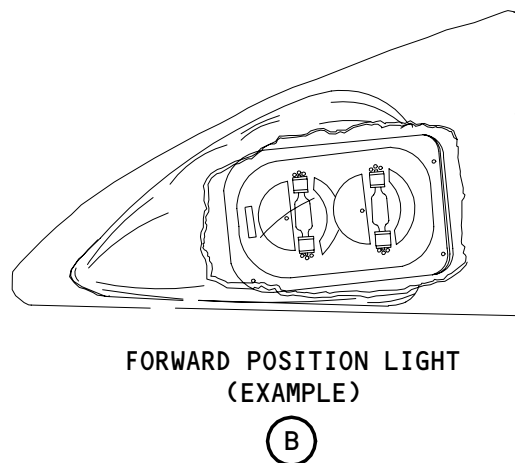
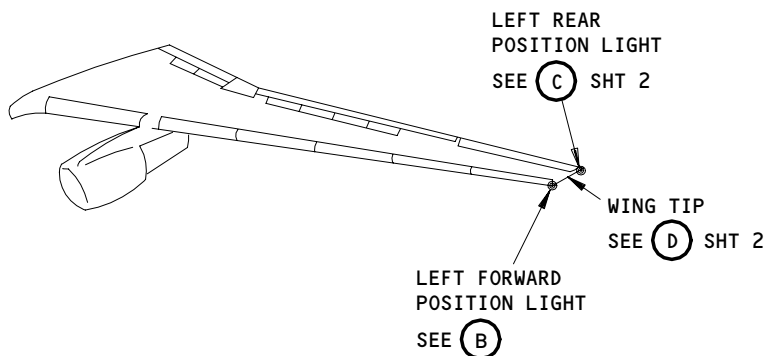
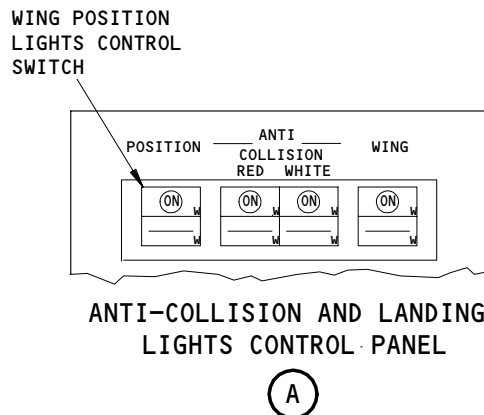
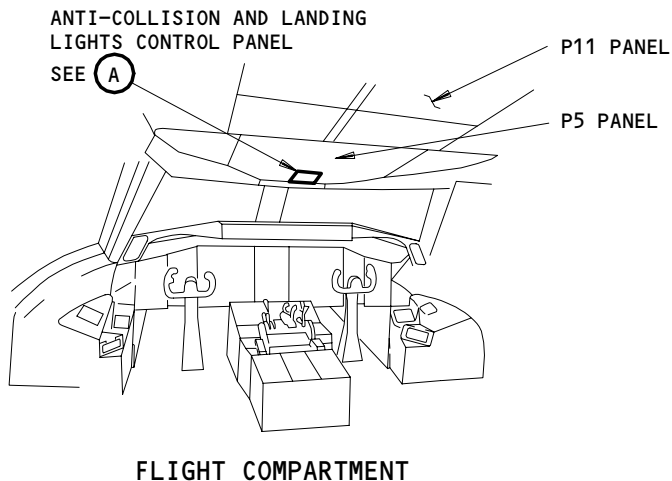

Position Lights - Component Location
Figure 102 (Sheet 1)

EFFECTIVITY	ALL
-------------	-----

33-43-00

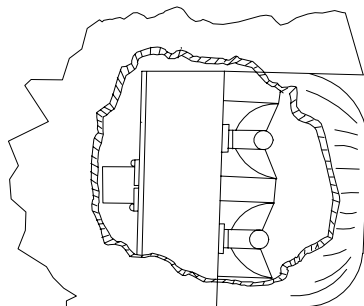

REAR POSITION LIGHT
(EXAMPLE)

(C)

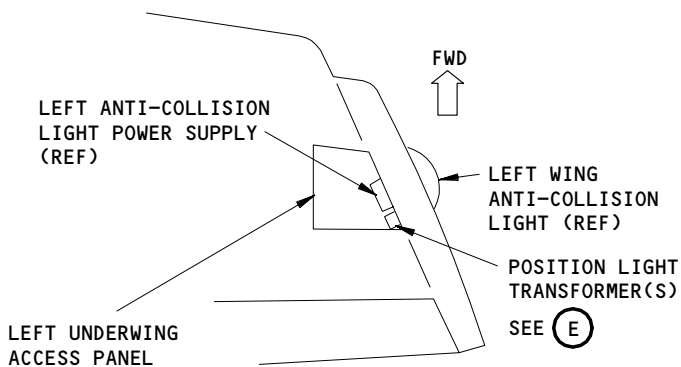

WINGTIP
(EXAMPLE)

(D) FROM SHT 1

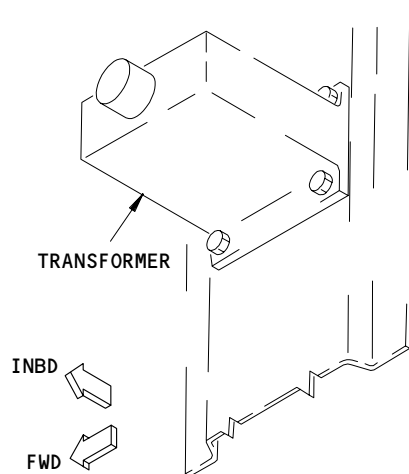

POSITION LIGHT TRANSFORMER
(EXAMPLE)

(E)

Position Lights - Component Location
Figure 102 (Sheet 2)

EFFECTIVITY	ALL
-------------	-----

223243

33-43-00

01

Page 103
May 10/94



BOEING
 767
 FAULT ISOLATION/MAINT MANUAL

ANTI-COLLISION LIGHTS

COMPONENT	FIG. 102 SHT	QTY	ACCESS/AREA	AMM REFERENCE
CIRCUIT BREAKER -	1	*	FLT COMPT, P11	*
LIGHT -				
L AND R WING ANTI-COLLISION	2	*	LEFT AND RIGHT WINGTIP	33-44-01
LOWER AND UPPER BODY ANTI-COLLISION	2	*	LOWER AND UPPER FUSELAGE	33-44-02
POWER SUPPLY -				
L AND R ANTI-COLLISION LIGHT	2	*	LEFT AND RIGHT WINGTIP	33-44-03
LOWER AND UPPER ANTI-COLLISION LIGHT	2	*	LOWER R WHEEL WELL COMPT AND UPPER FUSELAGE	33-44-04
SWITCH -	1	*	FLT COMPT, P5	*

* SEE THE SSM OR WDM FOR THE EQUIPMENT NUMBER, QUANTITY AND LOCATION OF EACH COMPONENT IN THE LIGHTING CIRCUIT.

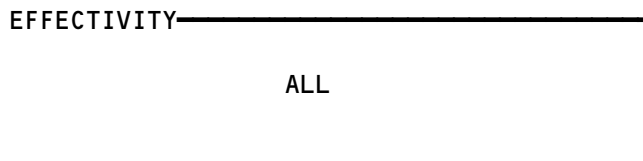
Anti-Collision Lights - Component Location
Figure 101



33-44-00

03

Page 101
Nov 10/96

610721

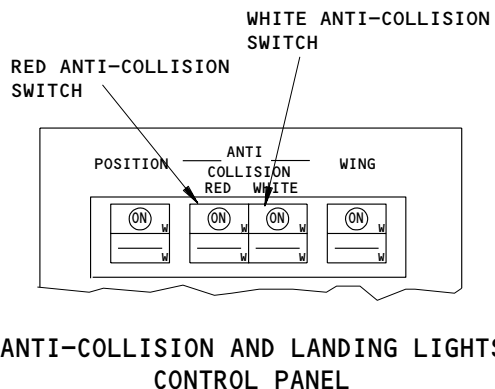
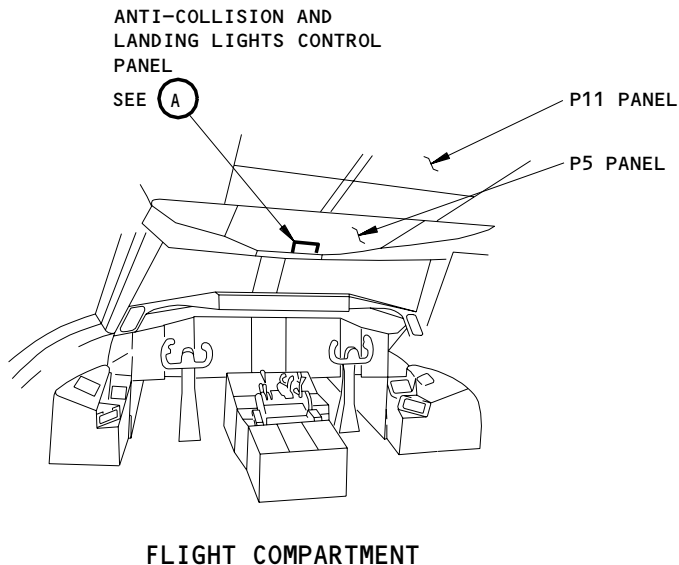

(A)

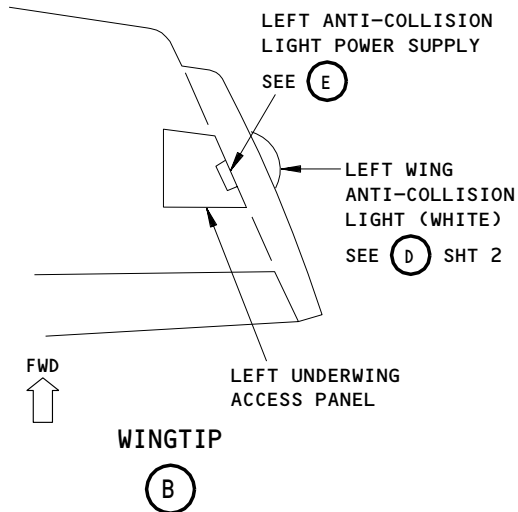
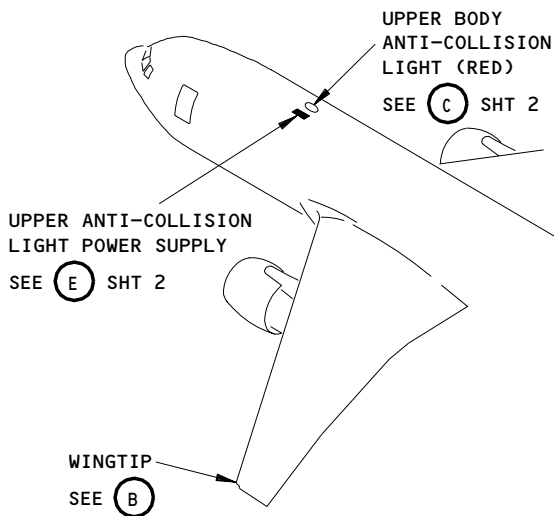

Anti-Collision Lights - Component Location
Figure 102 (Sheet 1)

EFFECTIVITY	ALL
-------------	-----

33-44-00

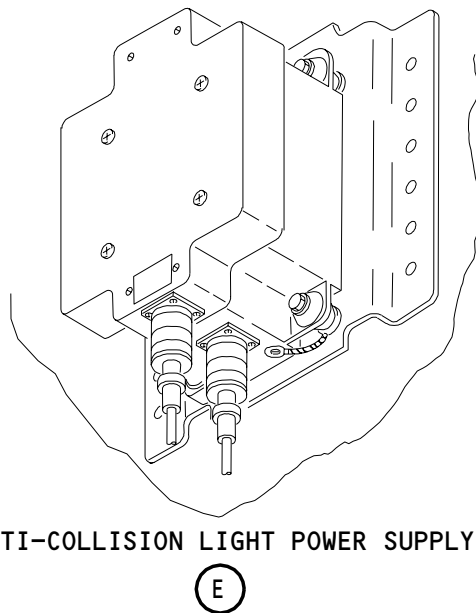
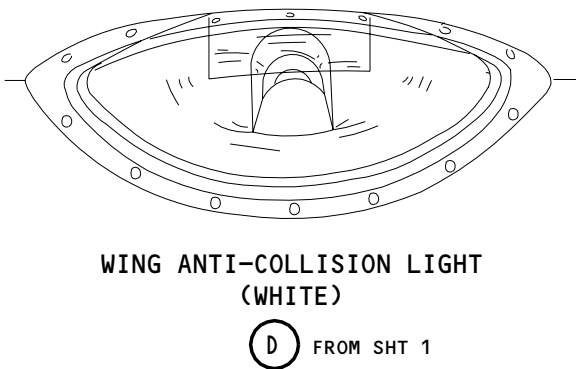
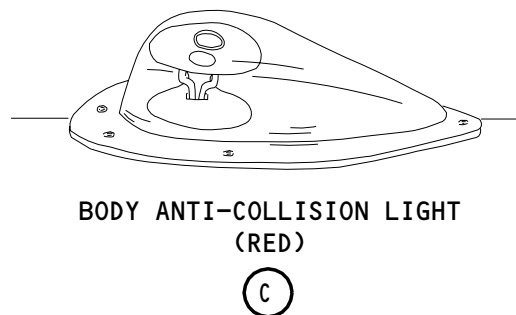
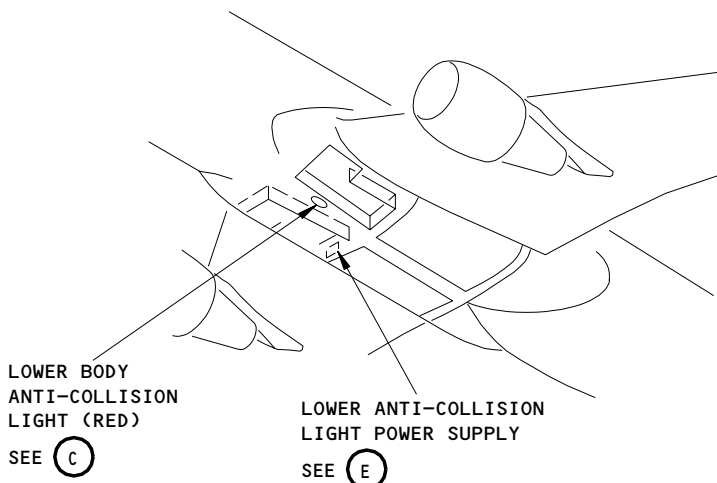

Anti-Collision Lights - Component Location
Figure 102 (Sheet 2)

EFFECTIVITY	ALL
-------------	-----

33-44-00



BOEING
 767
 FAULT ISOLATION/MAINT MANUAL

LOGO LIGHTS

COMPONENT	FIG. 102 SHT	QTY	ACCESS/AREA	AMM REFERENCE
CIRCUIT BREAKER -	--	*	119AL, MAIN EQUIP CTR, P33,P37	
LIGHT -	--	2	UPPER SURFACE OF INBOARD AND	*
LOGO			OUTBOARD HORIZONTAL STABILIZER	33-45-00
RELAY -			119AL, MAIN EQ CTR, P37	*
SWITCH -	--	1	FLT COMPT, P5	

* SEE THE SSM OR WDM FOR THE EQUIPMENT NUMBER, QUANTITY, AND LOCATION OF EACH COMPONENT IN THE LIGHTING CIRCUIT.

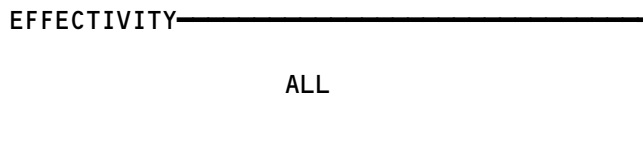
Logo Lights - Component Index
Figure 101



33-45-00

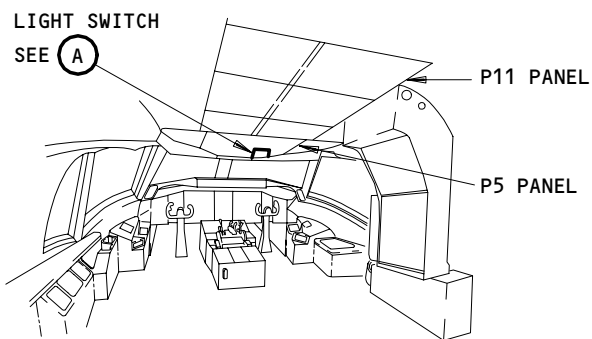

FLIGHT COMPARTMENT

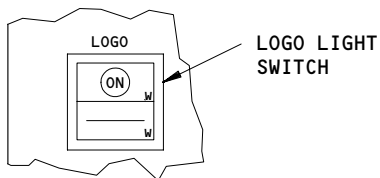
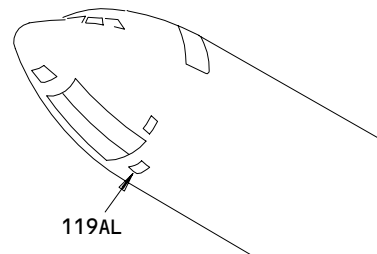

LIGHT SWITCH

(A)

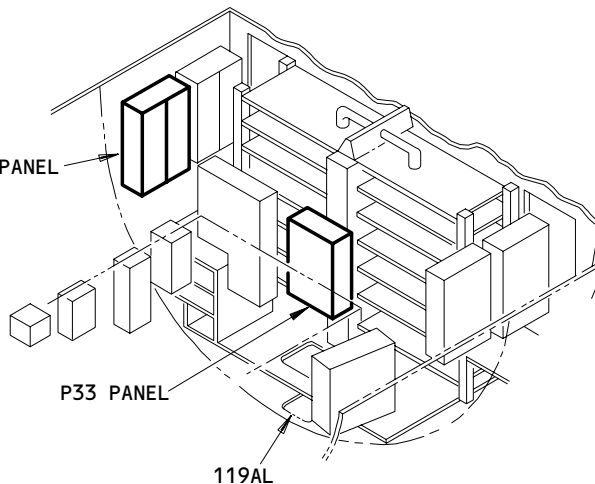

MAIN EQUIPMENT CENTER

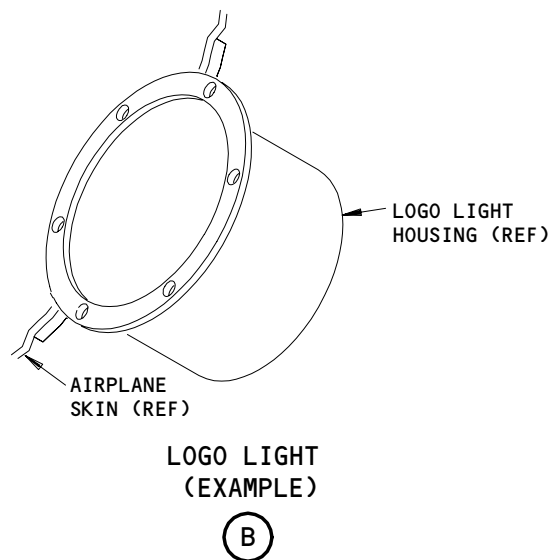
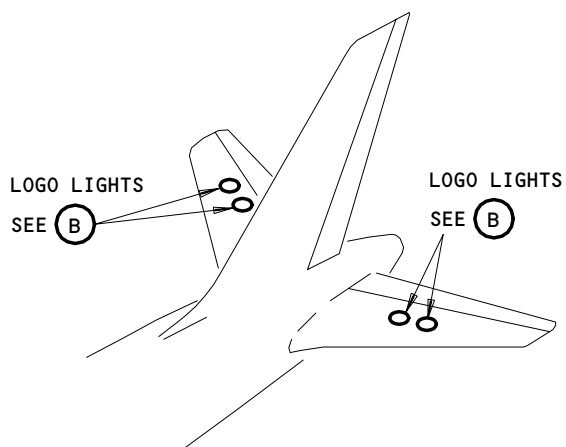

Logo Lights - Component Location
Figure 102

EFFECTIVITY

ALL

33-45-00

02

Page 102
May 10/95

720070

PREREQUISITES

MAKE SURE THESE CIRCUIT BREAKERS ARE CLOSED:
33J6, 33J7

MAKE SURE THESE CIRCUIT BREAKERS ARE OPEN:
37L5, 37L6

MAKE SURE THE AIRPLANE IS IN THIS CONFIGURATION:
ELECTRICAL POWER IS ON (AMM 24-22-00/201)

**LOGO LIGHTS
PROBLEMS**

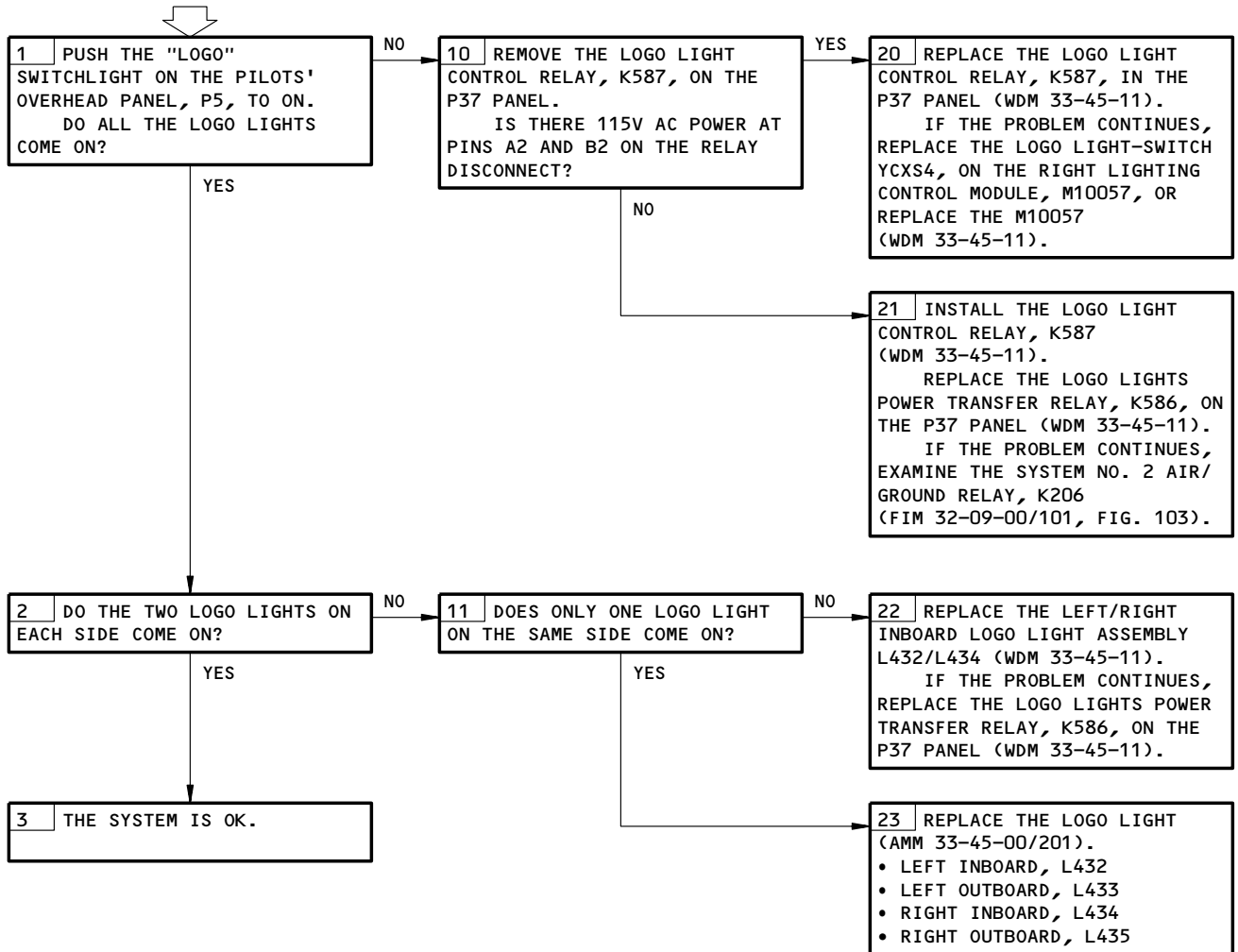

Logo Lights Problems
Figure 103

EFFECTIVITY

ALL

33-45-00

02

Page 103
Apr 22/01

48324

BOEING
767
FAULT ISOLATION/MAINT MANUAL

EMERGENCY LIGHTS

COMPONENT*	FIG. 102 SHT	QTY *	ACCESS/AREA	AMM REFERENCE
CIRCUIT BREAKER -			FLT COMPT, P11	*
COMPUTER - EICAS (FIM 31-41-00/101)			MAIN EQUIP CTR	*
LIGHT -				
AISLE	4		PASS. COMPT	33-51-05
DOOR	4		PASS. COMPT	33-51-03
FLOOR PROXIMITY				
EMERGENCY ESCAPE PATH	5		PASS. COMPT	33-51-10
EXIT IDENTIFIER SIGN	5		PASS. COMPT	33-51-09
INDICATOR	1		FLT COMPT, P5	*
LOWERED CEILING	4		PASS. COMPT	33-51-04
SLIDE	3		FUSELAGE	33-51-06
RELAY -			MAIN EQUIP CTR	*
SIGN - EXIT				
ELECTRICALLY ILLUMINATED	4		PASS. COMPT	33-51-01
SELF-ILLUMINATED 	4		PASS. COMPT	33-51-02
SUPPLY - POWER	3		PASS. COMPT	33-51-07
SWITCH -				
ATTENDANT'S	2		PASS. COMPT	*
PILOTS'	1		FLT COMPT	33-51-08
PROXIMITY	—		WING DOOR	*
TEST	2		NOSE LANDING GEAR, P40	*
TEST	2		PASS. COMPT	*

* SEE THE WDM OR SSM FOR THE EQUIPMENT NUMBER, QUANTITY, AND LOCATION OF EACH COMPONENT IN THE LIGHTING CIRCUIT

 NOT INSTALLED ON ALL AIRPLANES

Emergency Lights - Component Index
Figure 101

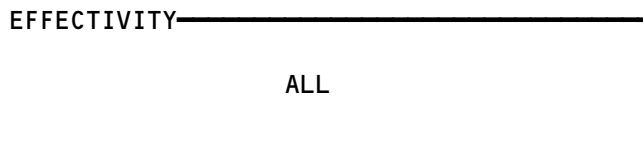

33-51-00

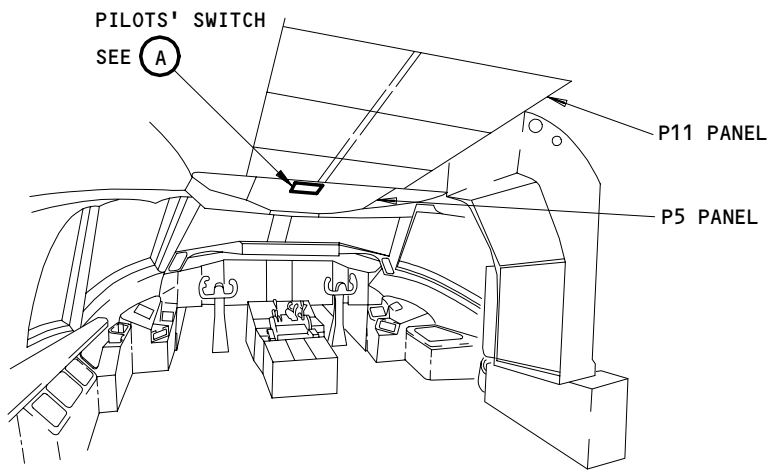

FLIGHT COMPARTMENT

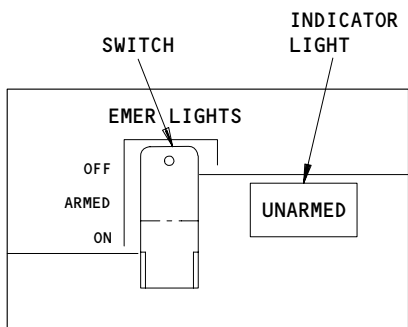

PILOTS' SWITCH (EXAMPLE)

(A)

Emergency Lights - Component Location
Figure 102 (Sheet 1)

EFFECTIVITY	ALL
-------------	-----

33-51-00

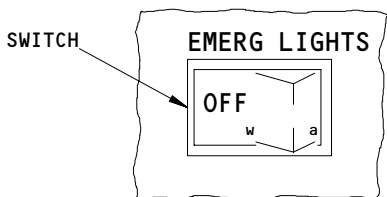

TEST SWITCH IN THE PASSENGER COMPARTMENT (EXAMPLE)

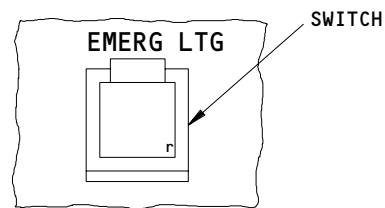

ATTENDANT'S SWITCH IN THE PASSENGER COMPARTMENT (EXAMPLE)

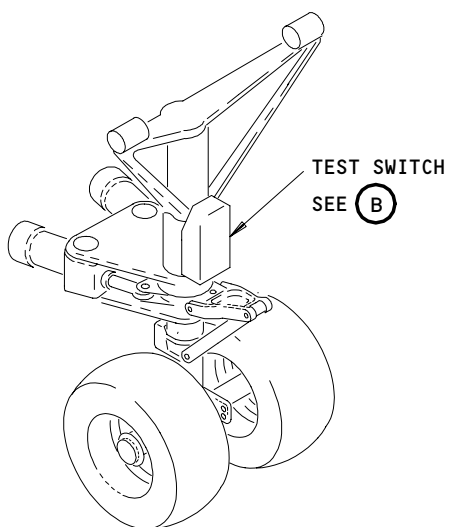

NOSE LANDING GEAR

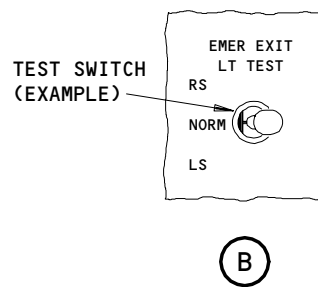

Emergency Lights - Component Location
Figure 102 (Sheet 2)

EFFECTIVITY	ALL
-------------	-----

192230

33-51-00

01

Page 103
May 10/94

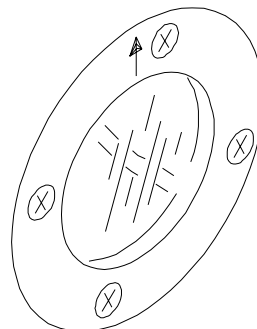

SLIDE LIGHT ON THE FUSELAGE
(EXAMPLE)

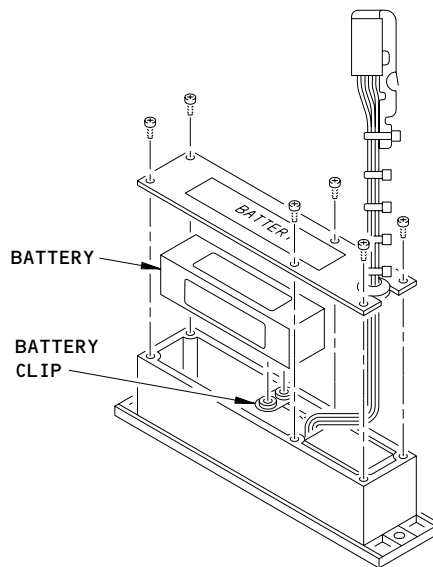
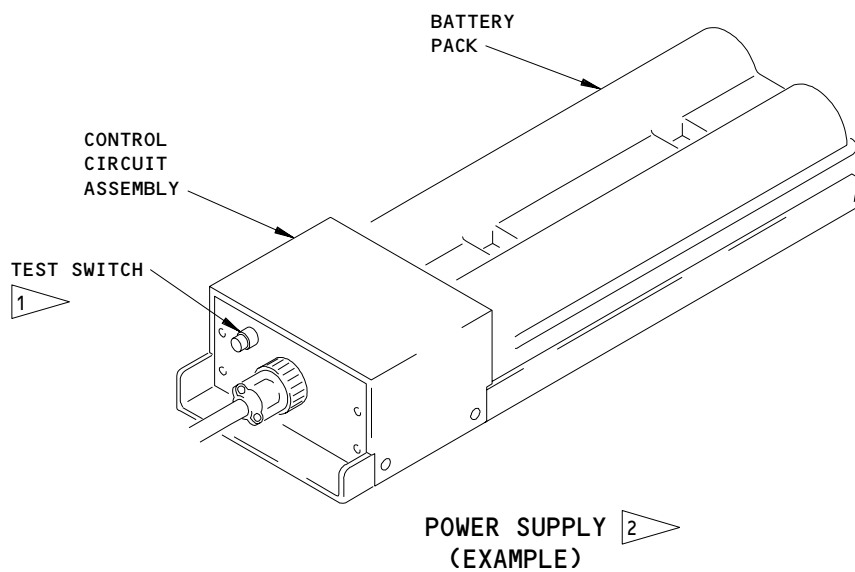

- 1 POWER SUPPLIES WITH A TEST SWITCH
- 2 ALL POWER SUPPLIES EXCEPT LSI
- 3 LSI POWER SUPPLIES

Emergency Lights - Component Location
Figure 102 (Sheet 3)

EFFECTIVITY	ALL
-------------	-----

33-51-00

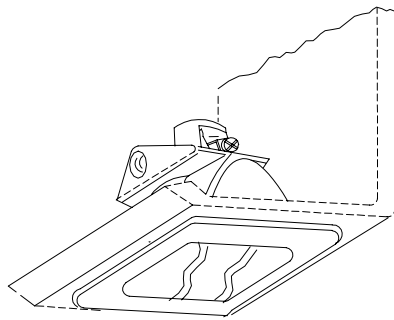

**AISLE LIGHT
(EXAMPLE)**

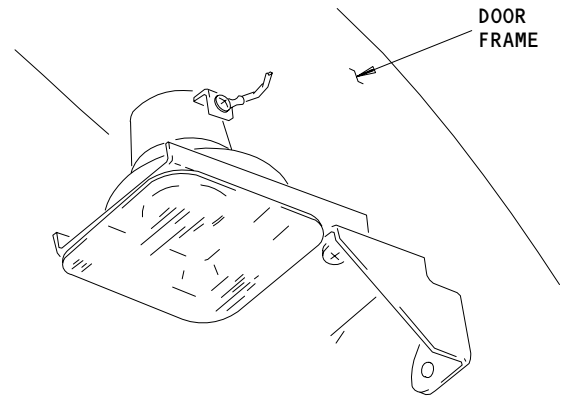

**DOOR LIGHT
(EXAMPLE)**

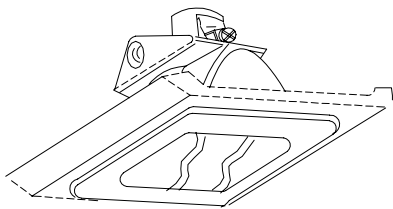

**LOWERED CEILING LIGHT
(EXAMPLE)**

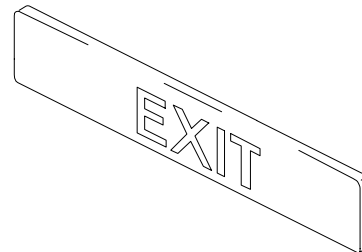

**EXIT SIGN
(EXAMPLE)**

**EMERGENCY LIGHTS IN THE
PASSENGER COMPARTMENT**

**Emergency Lights - Component Location
Figure 102 (Sheet 4)**

EFFECTIVITY	
	ALL

33-51-00

01

Page 105
May 10/94

851566

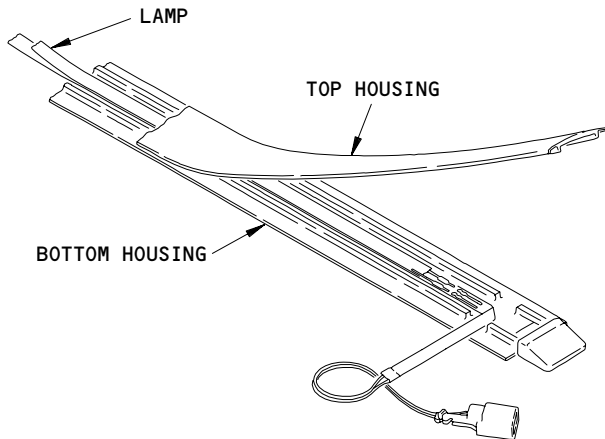

EMERGENCY ESCAPE PATH LIGHT
(EXAMPLE OF THE ELECTROLUMINESCENT TYPE)

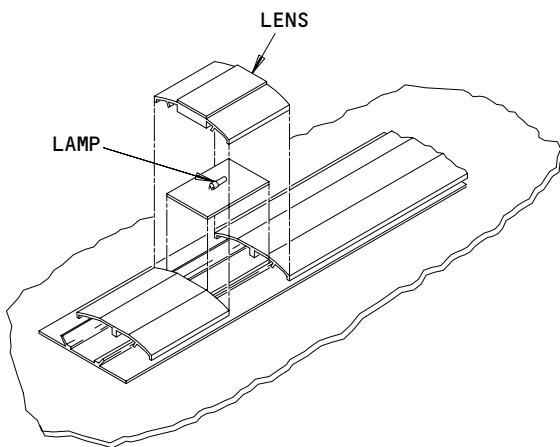

EMERGENCY ESCAPE PATH LIGHT
(EXAMPLE OF THE INCANDESCENT TYPE)

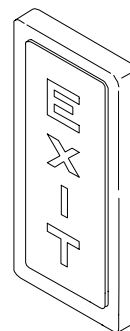

EXIT IDENTIFIER SIGN
(EXAMPLE)

EMERGENCY LIGHTS IN THE
PASSENGER COMPARTMENT

Emergency Lights - Component Location
Figure 102 (Sheet 5)

EFFECTIVITY	ALL
-------------	-----

33-51-00

INTERIOR EMERGENCY LIGHTS PROBLEMS

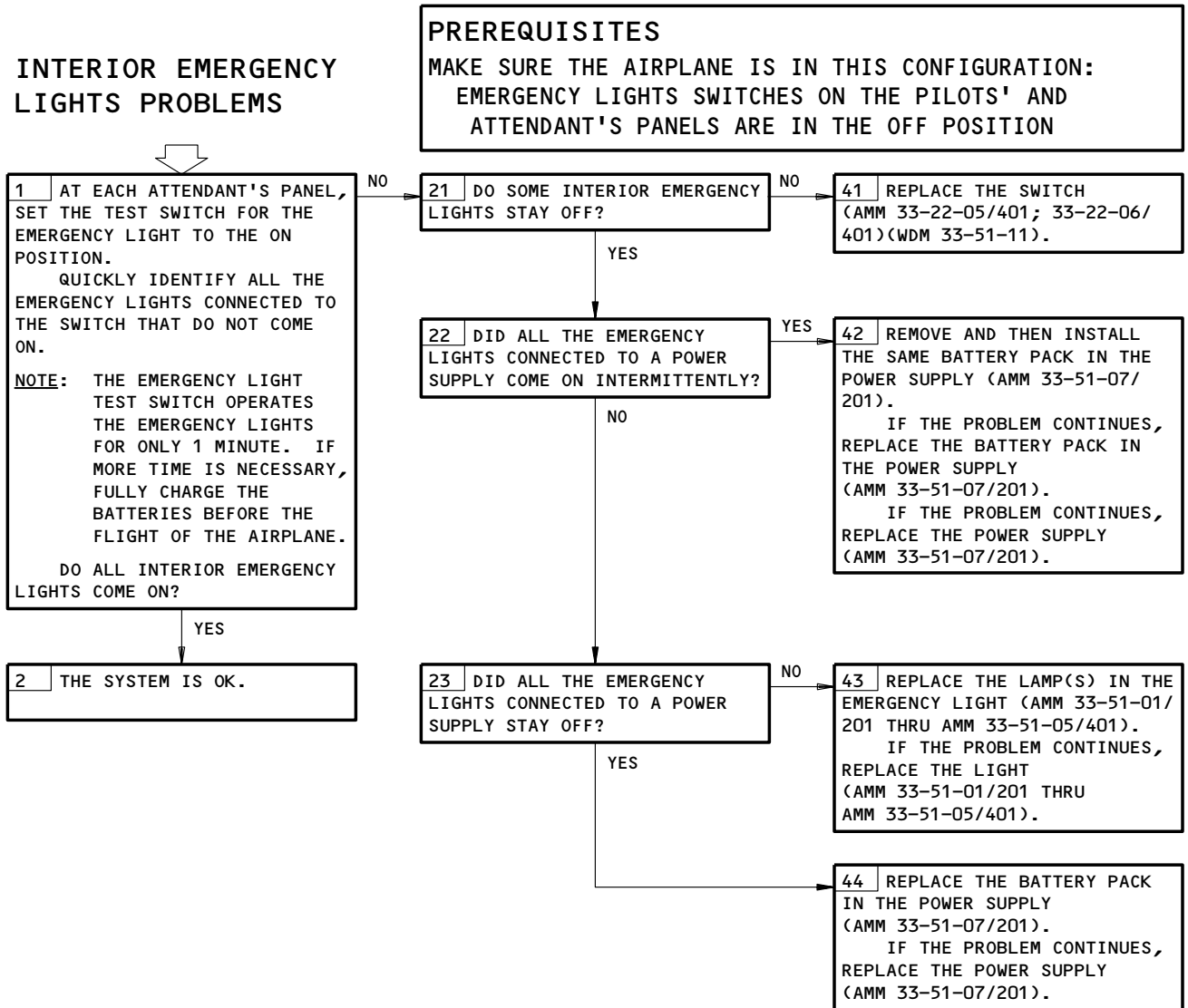

Interior Emergency Lights Problems
Figure 103 (Sheet 1)

EFFECTIVITY
AIRPLANES WITH INCANDESCENT FLOOR
PROXIMITY EMERGENCY LIGHTS

33-51-00

INTERIOR EMERGENCY LIGHTS PROBLEMS

PREREQUISITES
MAKE SURE THE AIRPLANE IS IN THIS CONFIGURATION:
EMERGENCY LIGHTS SWITCHES ON THE PILOTS' AND ATTENDANT'S PANELS ARE IN THE OFF POSITION

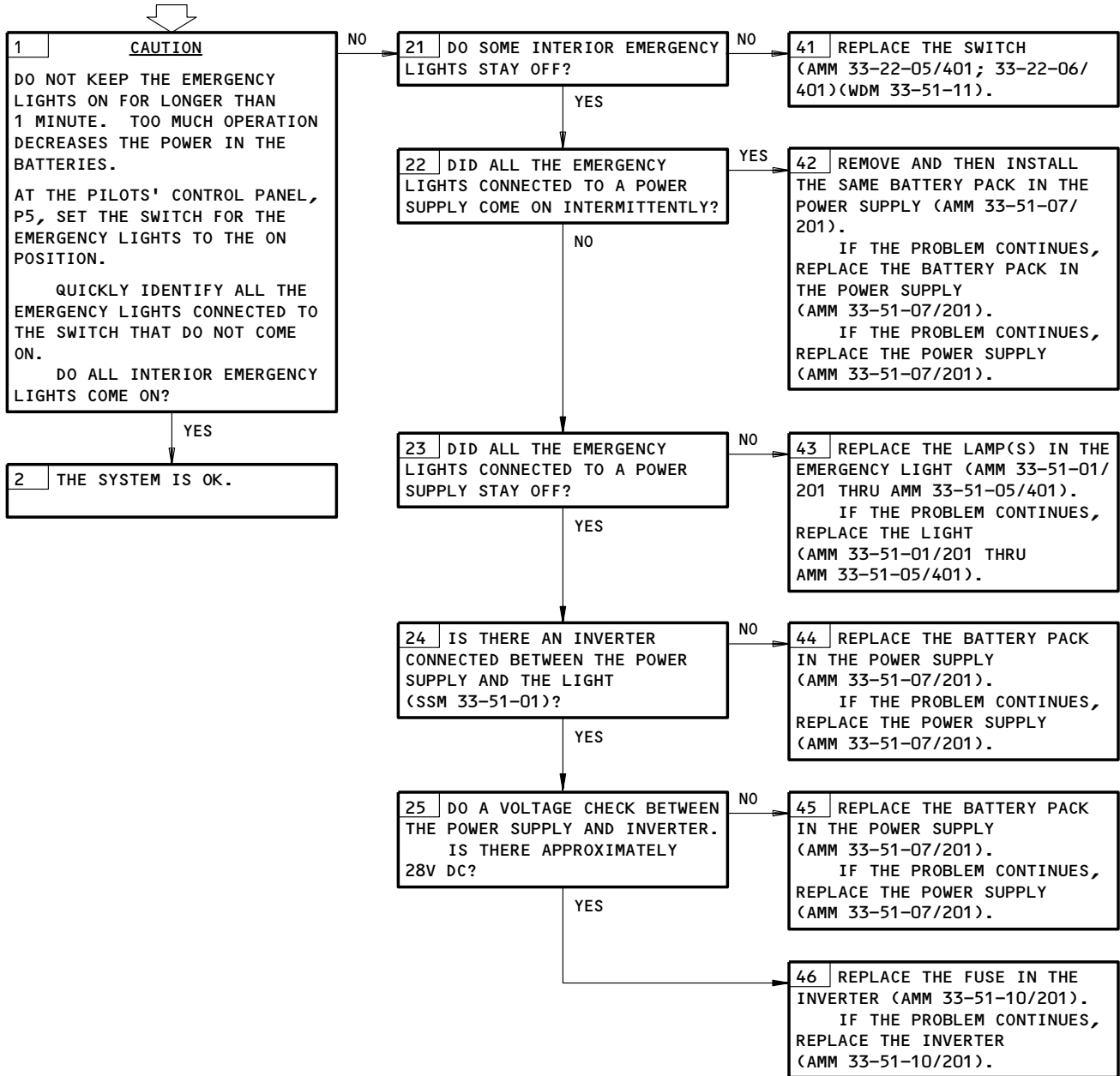

Interior Emergency Lights Problems
Figure 103 (Sheet 2)

EFFECTIVITY
AIRPLANES WITH ELECTROLUMINESCENT
FLOOR PROXIMITY EMERGENCY
LIGHTS

33-51-00

EXTERIOR EMERGENCY LIGHTS PROBLEMS

PREREQUISITES

MAKE SURE THE AIRPLANE IS IN THIS CONFIGURATION:
EMERGENCY LIGHT SWITCHES ON THE PILOTS' AND ATTENDANT'S PANELS ARE IN THE OFF POSITION

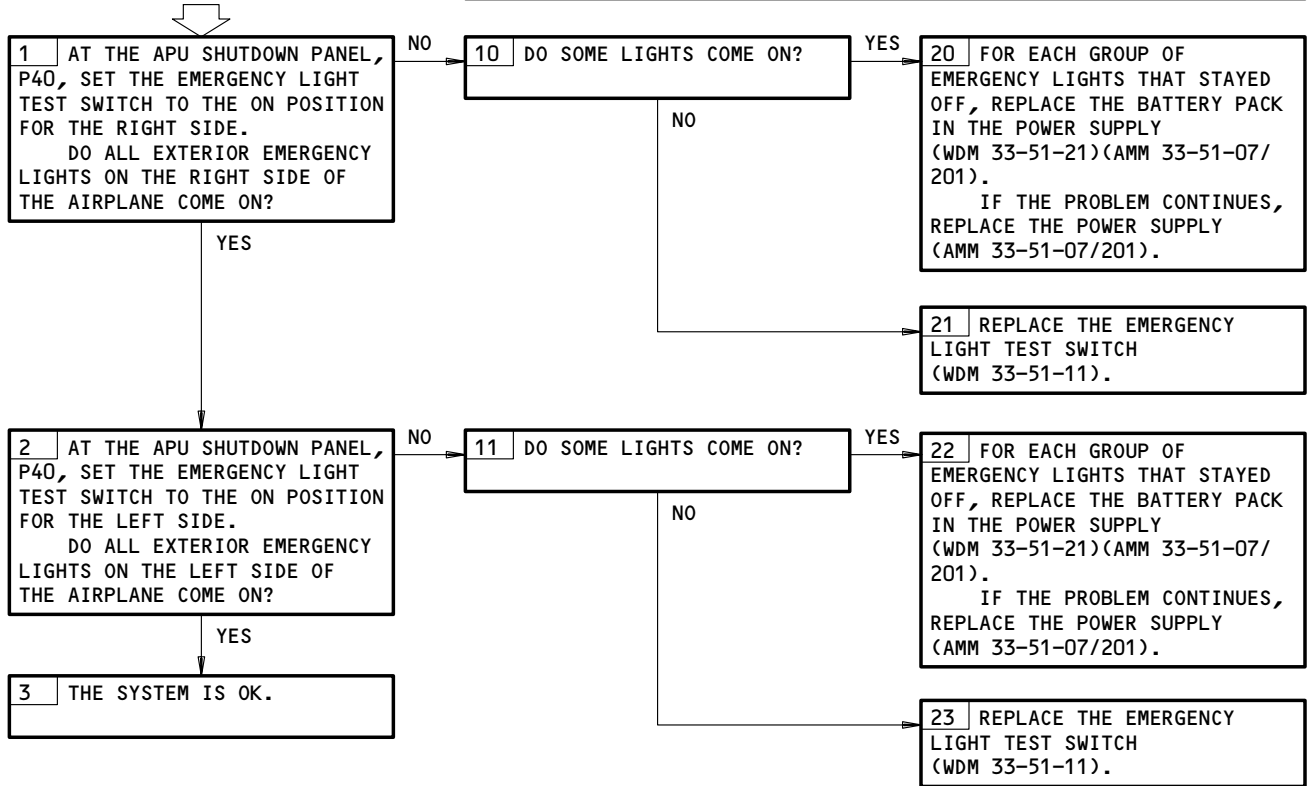

Exterior Emergency Lights Problems
Figure 104

EFFECTIVITY

ALL

33-51-00

01

Page 109
Feb 10/95

191953