

CHAPTER

29

HYDRAULIC POWER



CHAPTER 29
HYDRAULIC POWER

CH-SC-SU	Schem	Page	Sheet	Date	CH-SC-SU	Schem	Page	Sheet	Date
29-EFFECTIVE PAGES					29-00-03 (cont.)				
		1		Aug 05/2009			102	1	Jan 21/2005
		2		BLANK				2	Mar 14/2007
29-CONTENTS					29-00-04				
		1		Feb 06/2009		1	101		Jan 21/2005
		2		Jun 28/2006		2	101		Jan 21/2005
29-ALPHABETICAL INDEX						3	101		Jan 21/2005
		1		Jun 28/2006			102		Jan 21/2005
		2		BLANK	29-00-05				
29-00-00							101	1	Feb 06/2009
		101	1	Jan 21/2005				2	Jan 21/2005
			2	Mar 14/2007	29-00-06				
29-00-01							101	1	Jan 21/2005
		101	1	Jan 21/2005				2	Jan 21/2005
			2	Jan 21/2005	29-00-07				
29-00-02							101	1	Jan 21/2005
		101	1	Jan 21/2005				2	Jan 21/2005
			2	Jan 21/2005	29-00-08				
		102	1	Jan 21/2005			101		Jan 21/2005
			2	Jan 21/2005					
		103	1	Jan 21/2005					
			2	Jan 21/2005					
29-00-03									
		101	1	Jan 21/2005					
			2	Mar 14/2007					

A = Added, R = Revised, D = Deleted, O = Overflow

29-EFFECTIVE PAGES

Page 1
Aug 05/2009

D280T232



CHAPTER 29
HYDRAULIC POWER

Title	CH-SC-SU	Schem	Page	Sheet	Date	Effectivity	
HYDRAULIC POWER							
HYDRAULICS- SIMPLIFIED	29-00-00		101	1	Jan 21/2005	ALL	
				2	Mar 14/2007	ALL	
HYDRAULIC SUPPLY FILL AND MONITOR	29-00-01		101	1	Jan 21/2005	ALL	
				2	Jan 21/2005	ALL	
HYDRAULIC POWER- LEFT	29-00-02		101	1	Jan 21/2005	050-099	
				2	Jan 21/2005	050-099	
				102	1	Jan 21/2005	150-199 275-278
					2	Jan 21/2005	150-199 275-278
				103	1	Jan 21/2005	280-299
					2	Jan 21/2005	280-299
HYDRAULIC POWER- RIGHT	29-00-03		101	1	Jan 21/2005	050-099 150-199 275-278	
				2	Mar 14/2007	050-099 150-199 275-278	
				102	1	Jan 21/2005	280-299
					2	Mar 14/2007	280-299
HYDRAULIC POWER- CENTER	29-00-04	1	101		Jan 21/2005	ALL	
		2			Jan 21/2005	ALL	
		3			Jan 21/2005	050-099 275-299	
				102	Jan 21/2005	150-199	
AIR DRIVEN PUMP	29-00-05		101	1	Feb 06/2009	ALL	
				2	Jan 21/2005	ALL	
RAM AIR TURBINE	29-00-06		101	1	Jan 21/2005	ALL	
				2	Jan 21/2005	ALL	

CHAPTER 29
HYDRAULIC POWER

Title	CH-SC-SU	Schem	Page	Sheet	Date	Effectivity
HYDRAULICS ENGINE IND AND CREW ALERTING SYSTEM INDICATION	29-00-07		101	1	Jan 21/2005	ALL
				2	Jan 21/2005	ALL
POWER TRANSFER UNIT CONTROL	29-00-08		101		Jan 21/2005	ALL

**CHAPTER 29
HYDRAULIC POWER**

CH-SC-SU	Title
29-00-05	AIR DRIVEN PUMP
29-00-04	HYDRAULIC POWER- CENTER
29-00-02	HYDRAULIC POWER- LEFT
29-00-03	HYDRAULIC POWER- RIGHT
29-00-01	HYDRAULIC SUPPLY FILL AND MONITOR
29-00-07	HYDRAULICS ENGINE IND AND CREW ALERTING SYSTEM INDICATION
29-00-00	HYDRAULICS- SIMPLIFIED
29-00-08	POWER TRANSFER UNIT CONTROL
29-00-06	RAM AIR TURBINE

CH-SC-SU	Title
----------	-------

29-ALPHABETICAL INDEX

THIS PAGE INTENTIONALLY LEFT BLANK

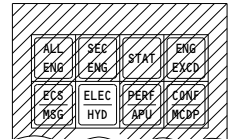
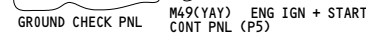
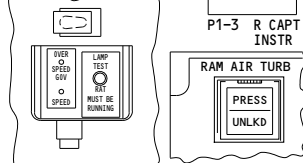
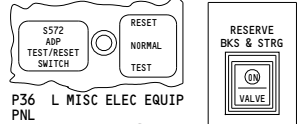
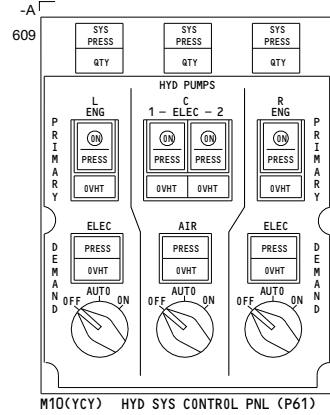

HYDRAULIC SYSTEM CONTROLS AND INDICATORS

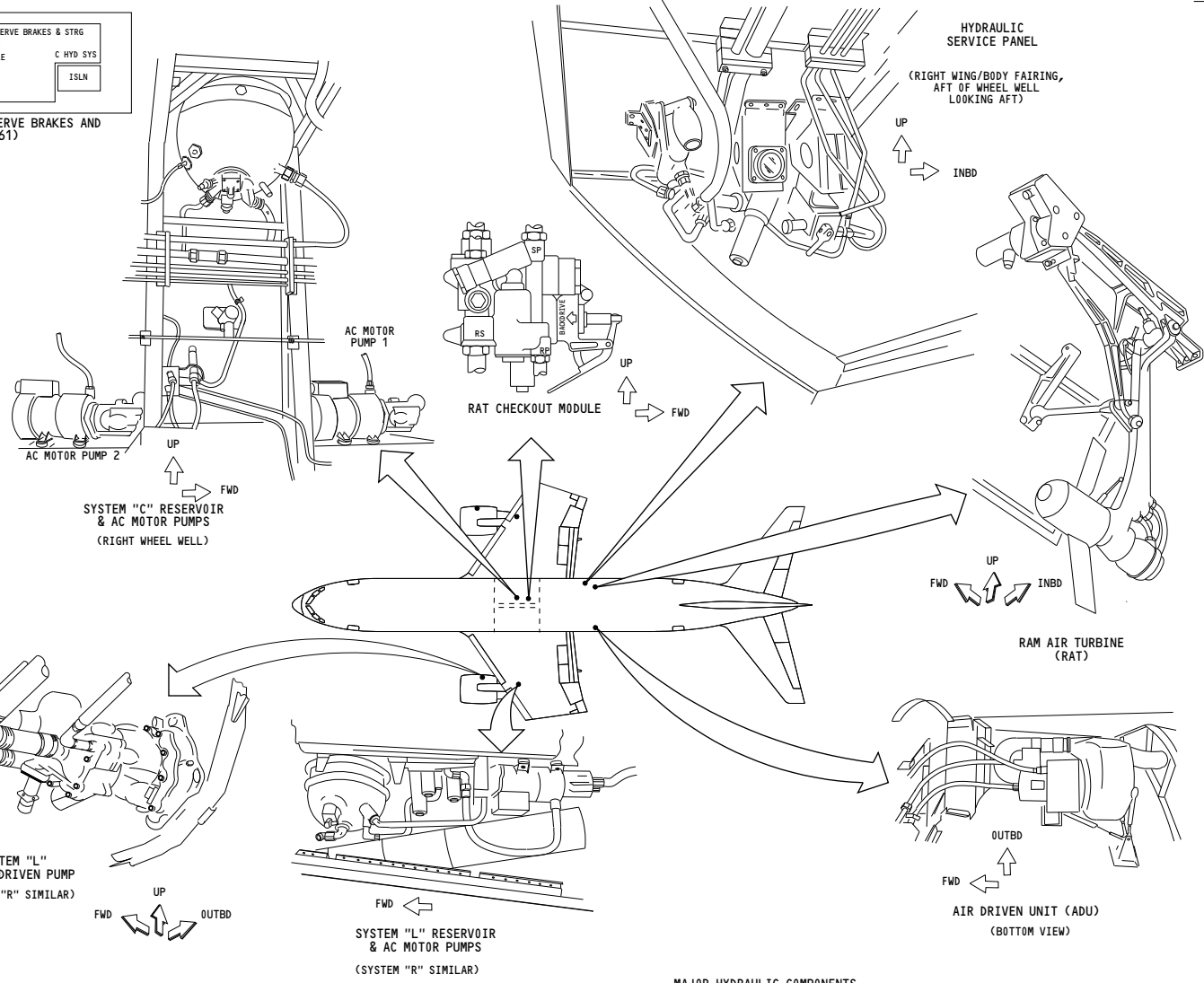

ALL	HYDRAULICS-SIMPLIFIED
	D280T232

29-00-00

-A
610

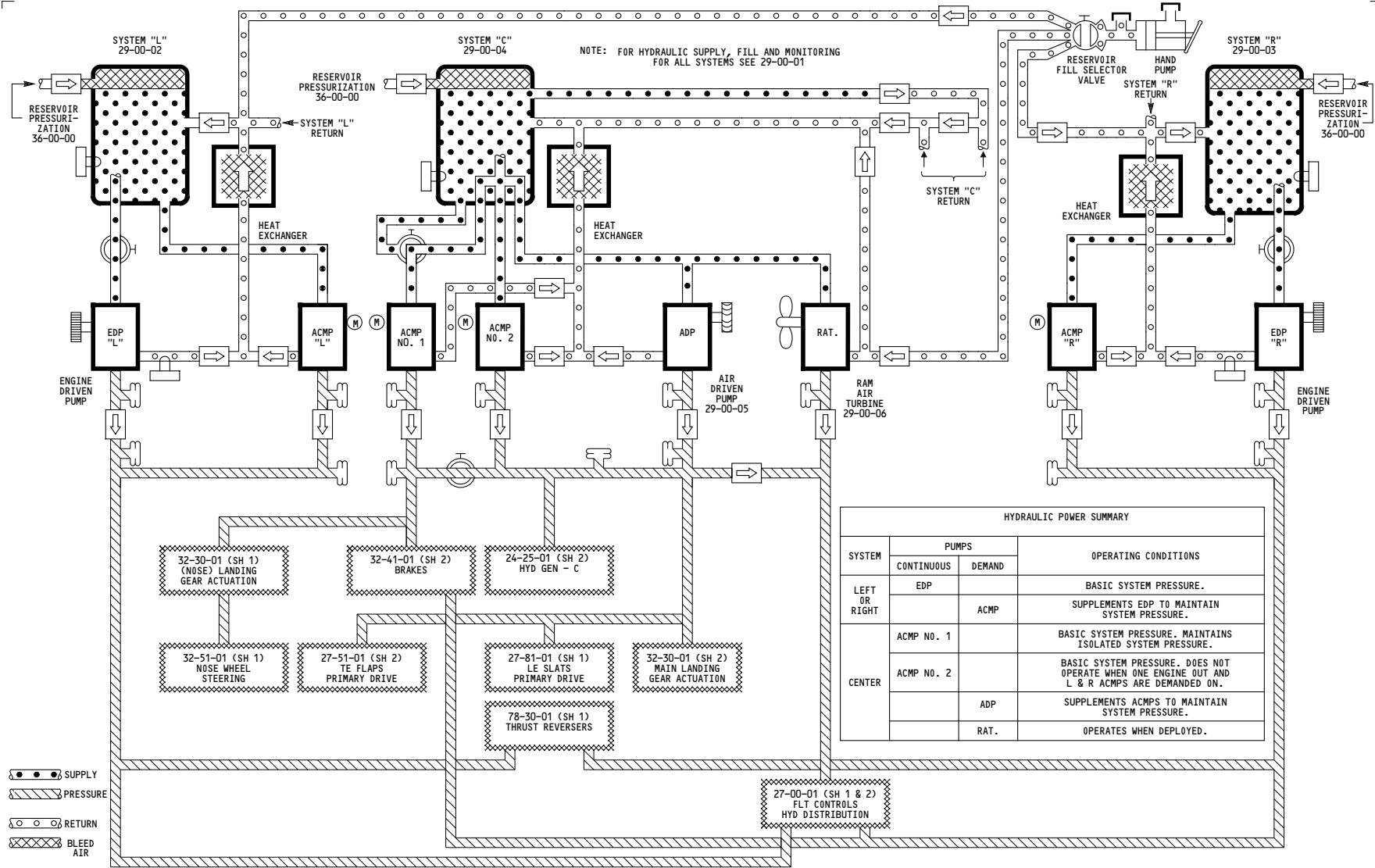

ALL	HYDRAULICS-SIMPLIFIED
	D280T232

29-00-00

-A
609

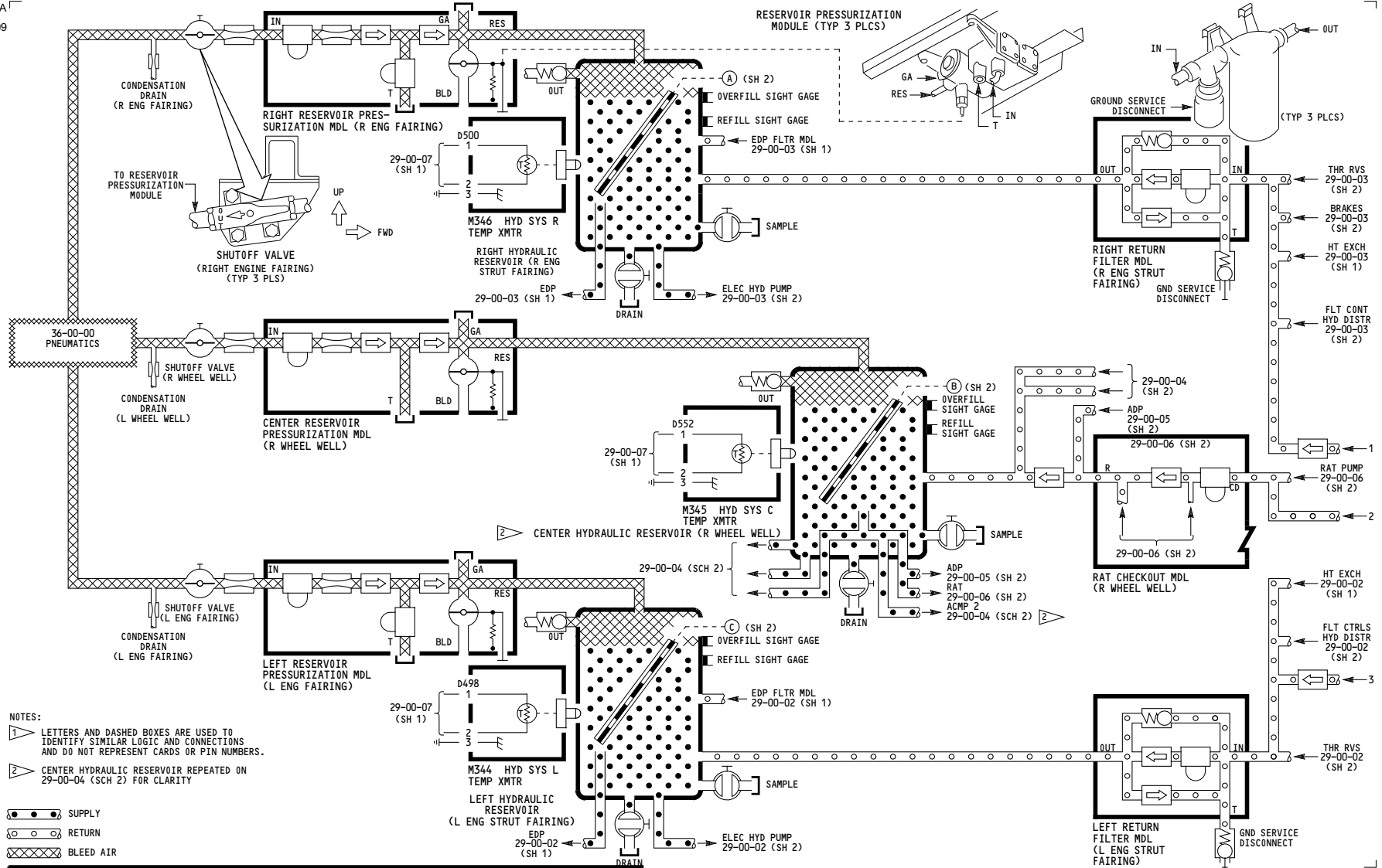

- NOTES:
- 1 LETTERS AND DASHED BOXES ARE USED TO IDENTIFY SIMILAR LOGIC AND CONNECTIONS AND DO NOT REPRESENT CARDS OR PIN NUMBERS.
 - 2 CENTER HYDRAULIC RESERVOIR REPEATED ON 29-00-04 (SCH 2) FOR CLARITY
- SUPPLY
 - ○ ○ RETURN
 - ××× BLEED AIR

ALL	<p>HYDRAULIC SUPPLY FILL AND MONITOR</p> <p>D280T232</p>
-----	---

29-00-01

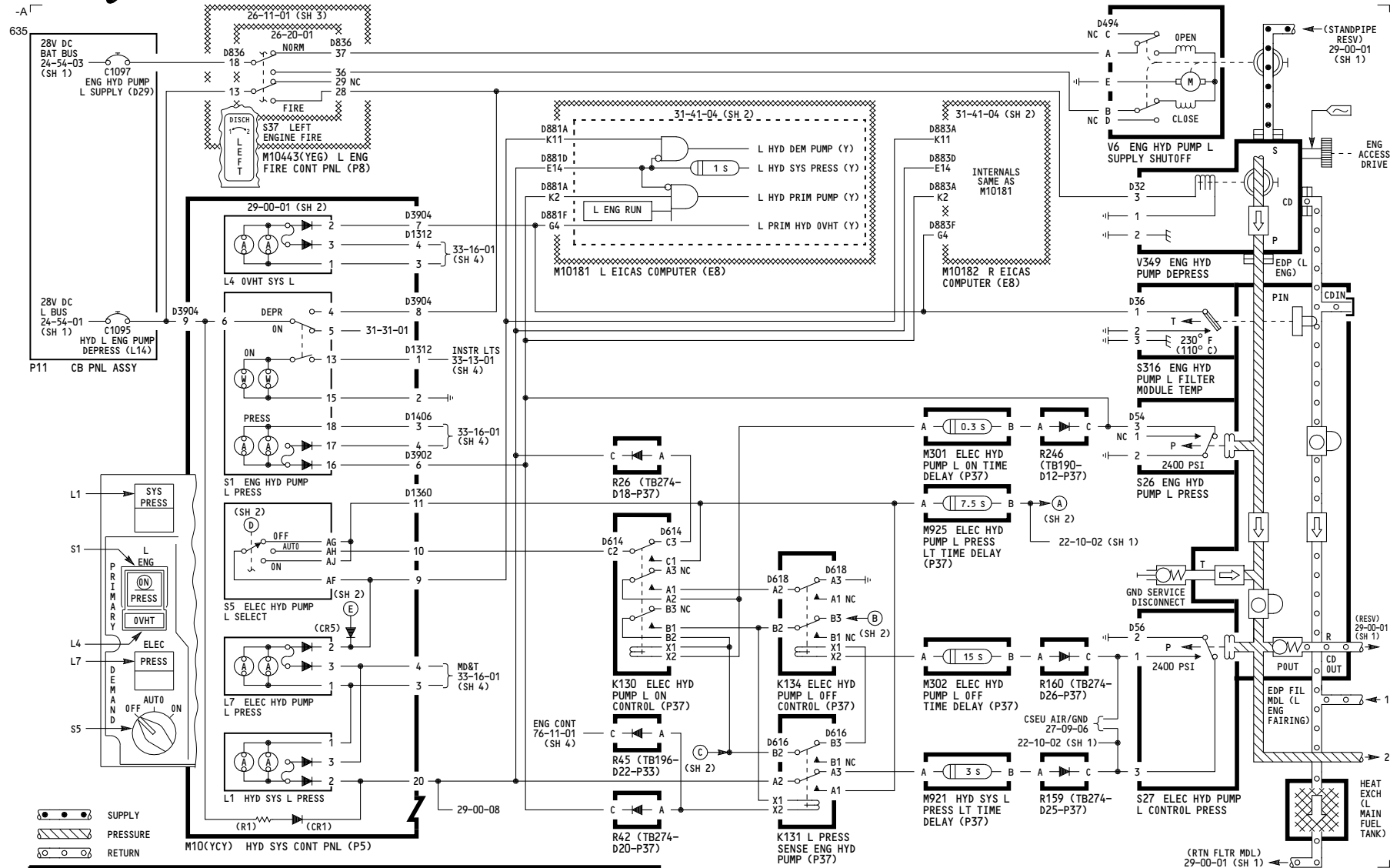

050-099	HYDRAULIC POWER-LEFT
D280T232	

29-00-02

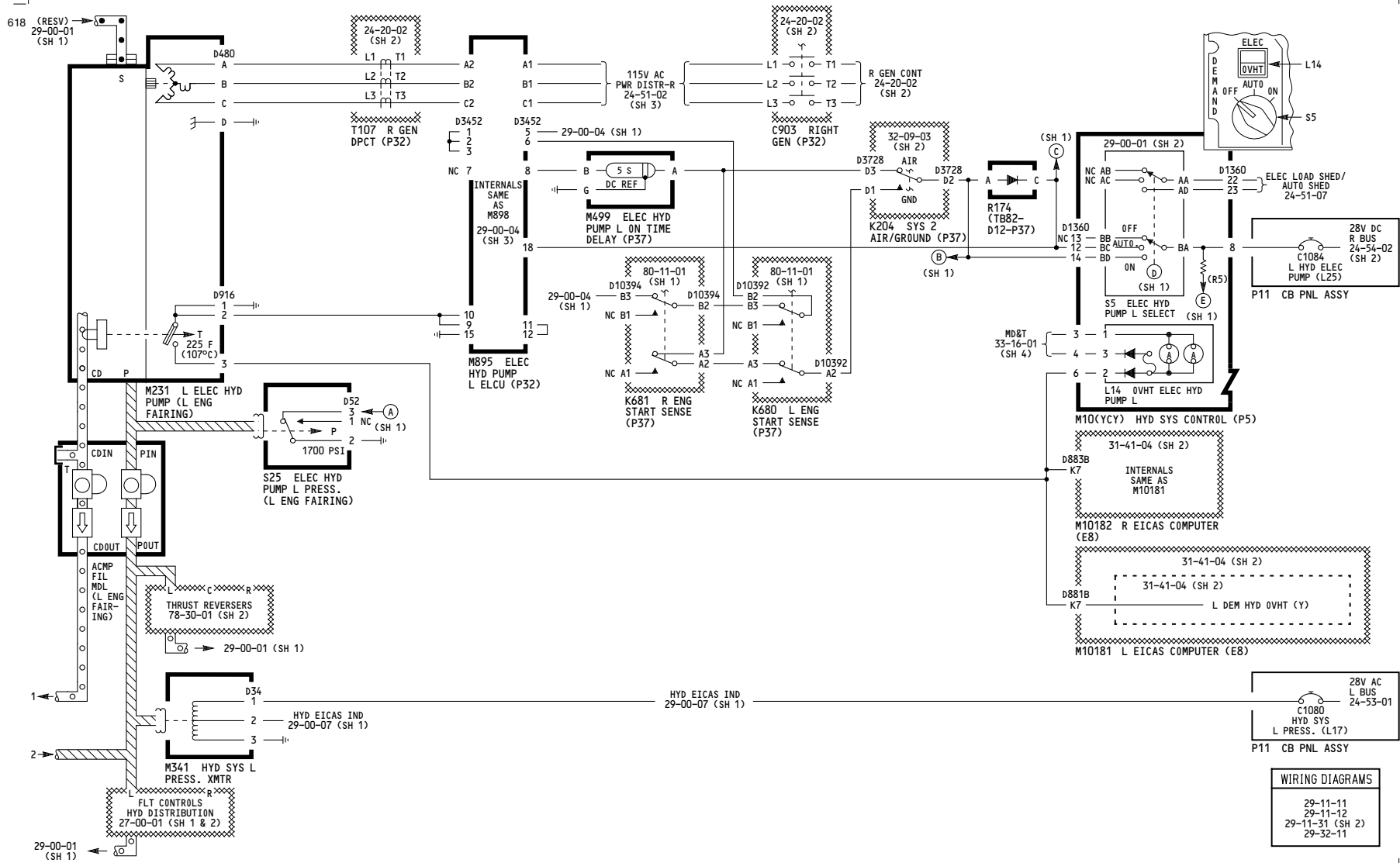

050-099	HYDRAULIC POWER-LEFT
D280T232	

WIRING DIAGRAMS
 29-11-11
 29-11-12
 29-11-31 (SH 2)
 29-32-11

29-00-02

BOEING PROPRIETARY - Copyright © - Unpublished Work - See title page for details.

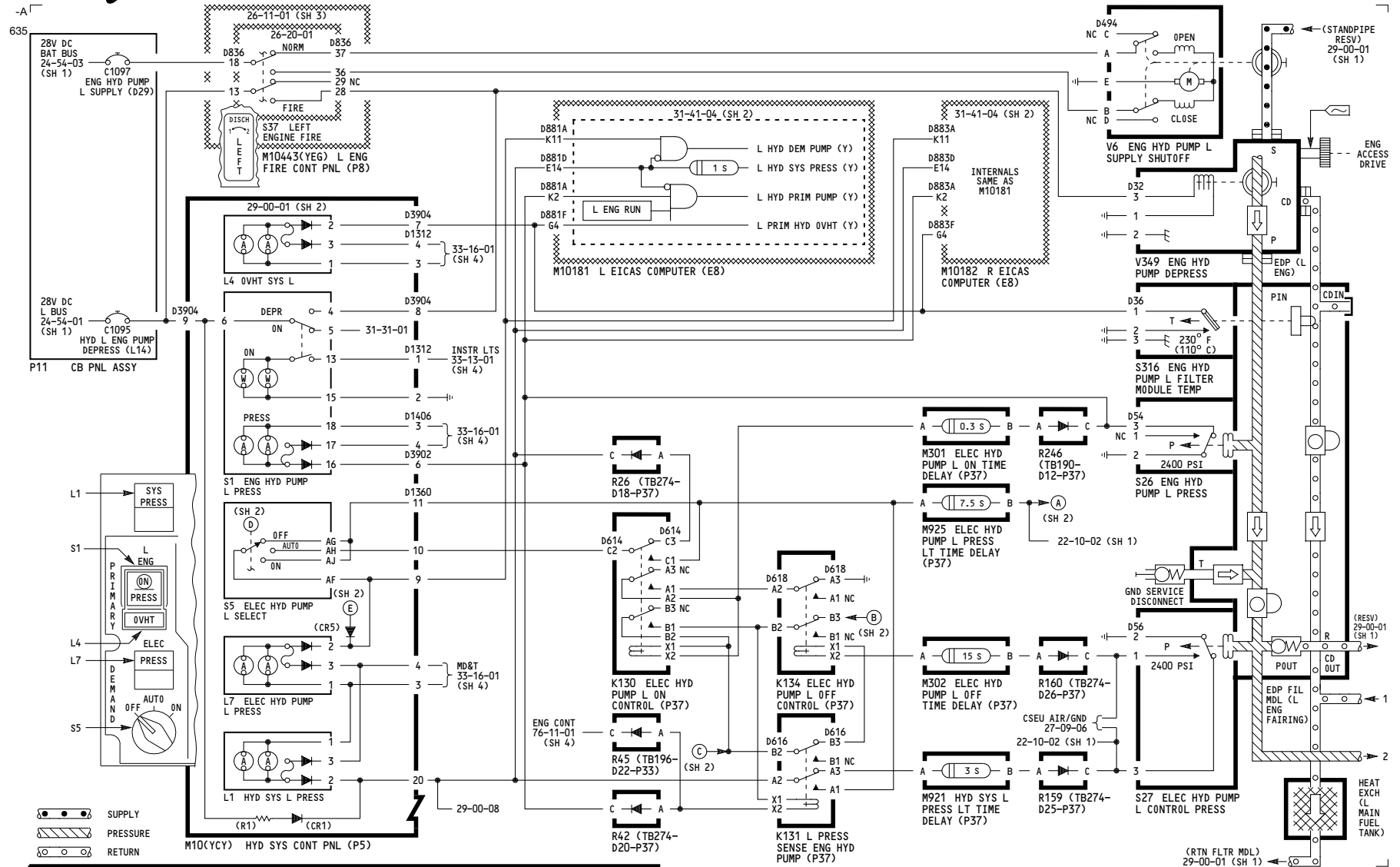

150-199, 275-278

HYDRAULIC POWER-LEFT

D280T232

29-00-02

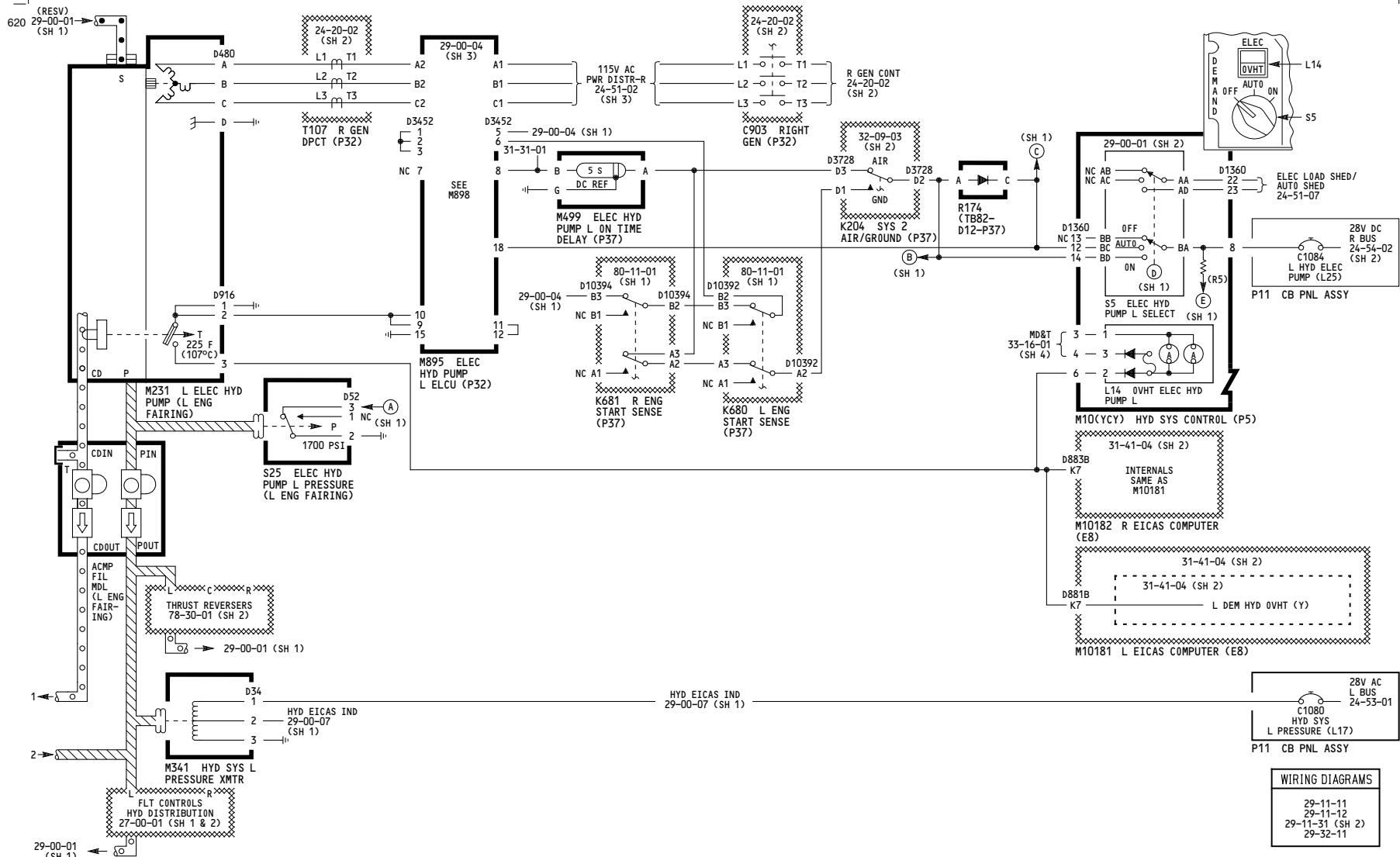

150-199, 275-278

HYDRAULIC POWER-LEFT

D280T232

WIRING DIAGRAMS

29-11-11
29-11-12
29-11-31 (SH 2)
29-32-11

29-00-02

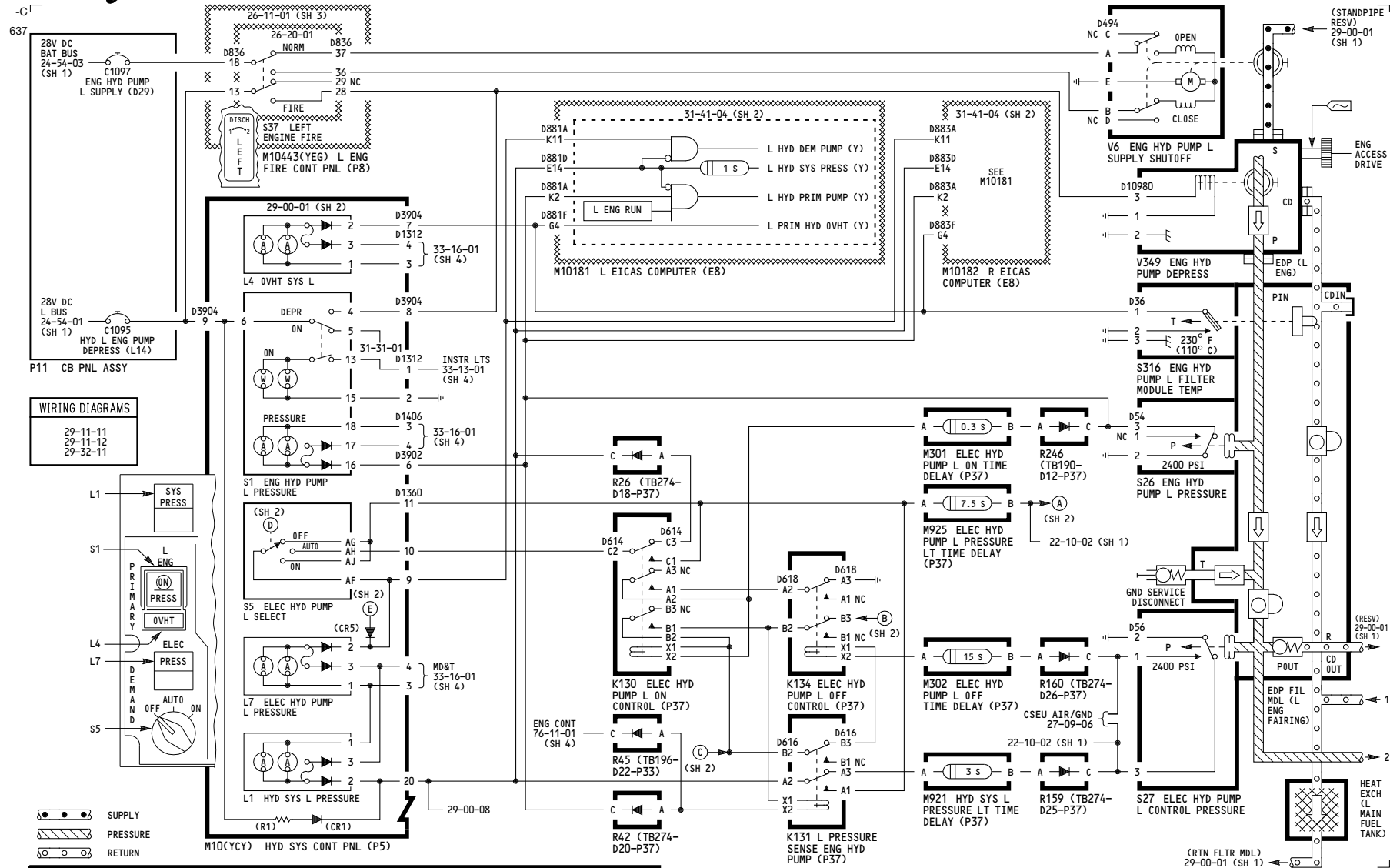

280-299

HYDRAULIC POWER-LEFT

D280T232

29-00-02

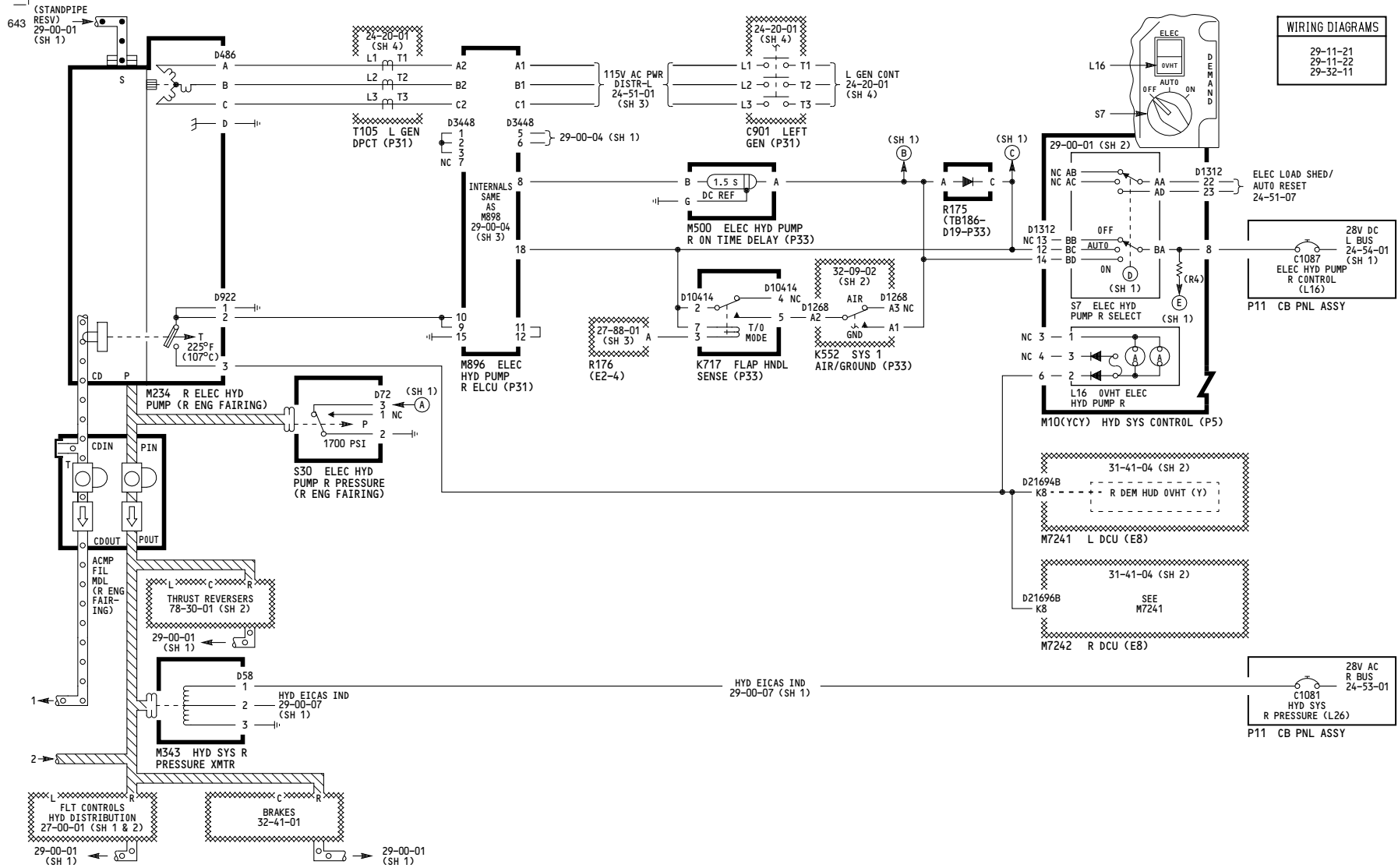

29-00-03

Page 102
Sheet 2
Mar 14/2007

-B
610

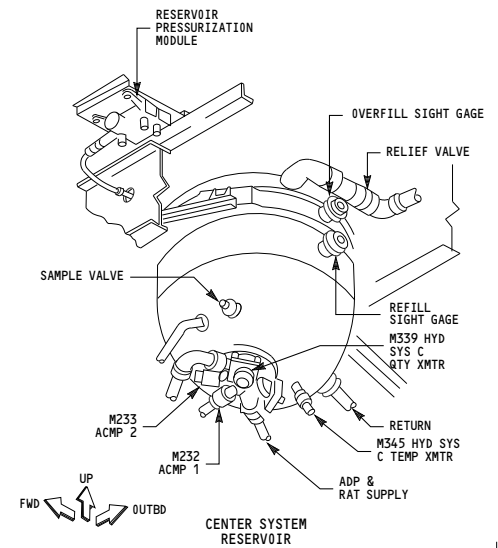
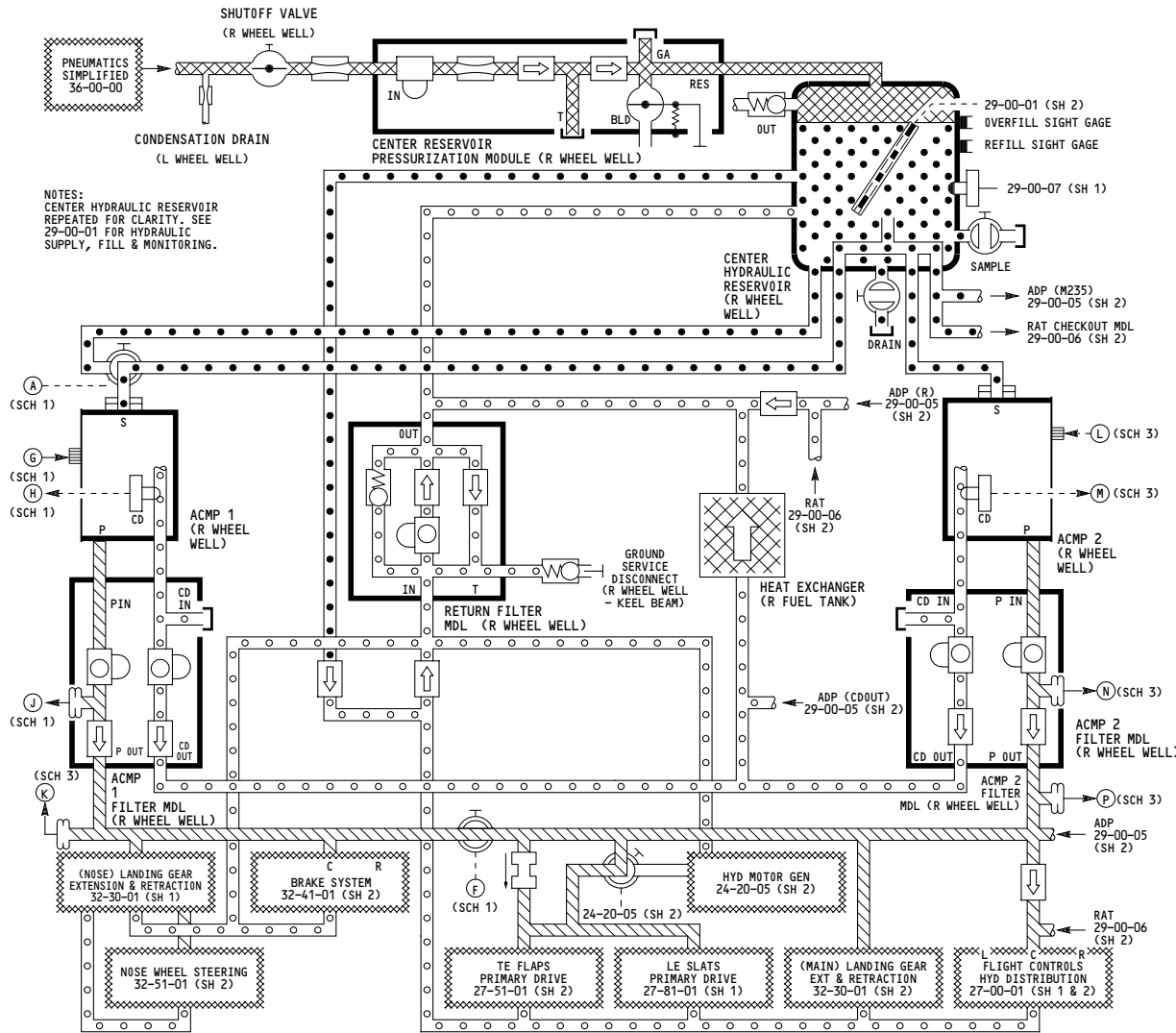

ALL

HYDRAULIC POWER-CENTER

D280T232

29-00-04
 Schem 2
 Page 101
 Jan 21/2005

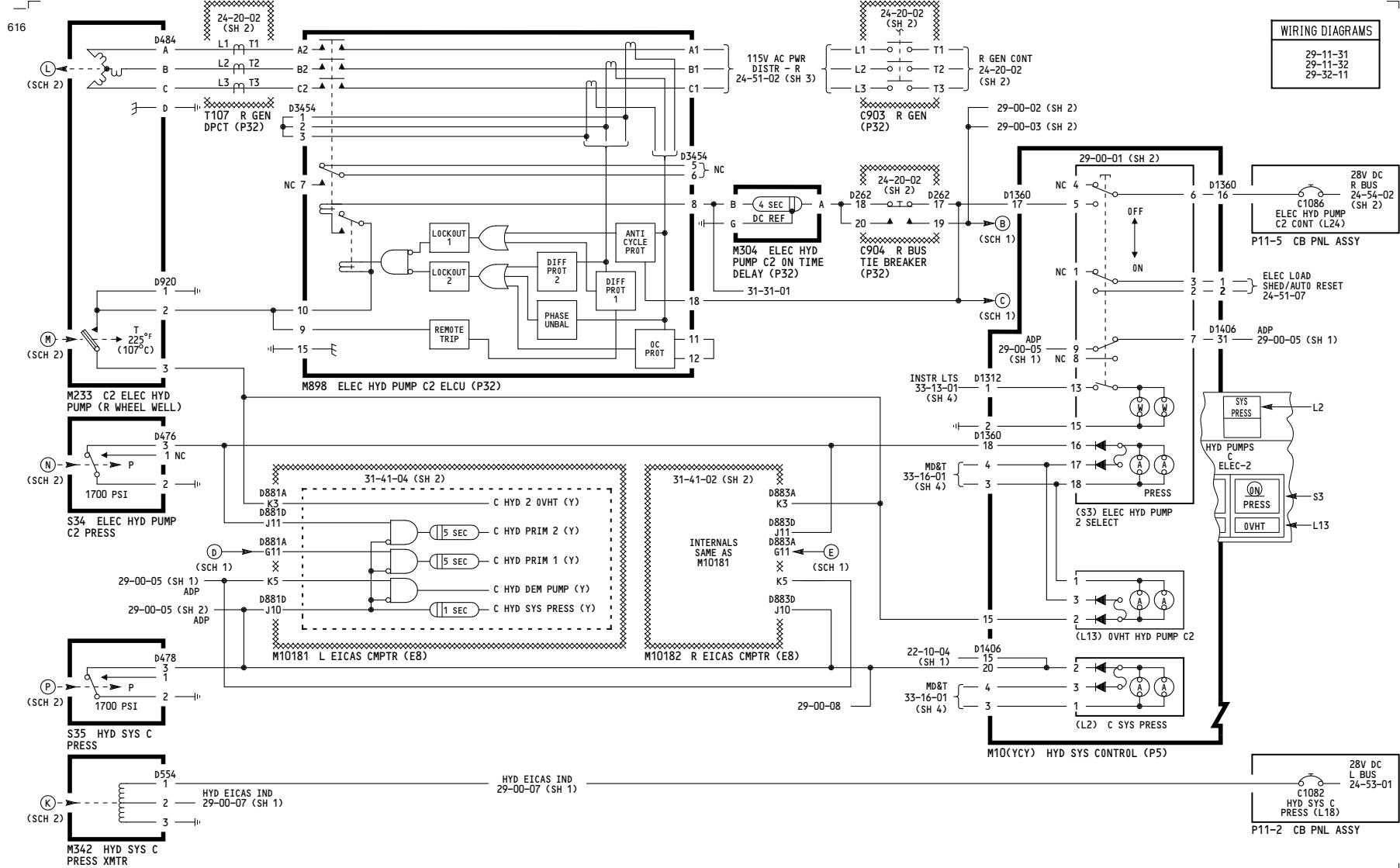

150-199

HYDRAULIC POWER-CENTER

D280T232

29-00-04

Schem 3
Page 102

Jan 21/2005

-A
613

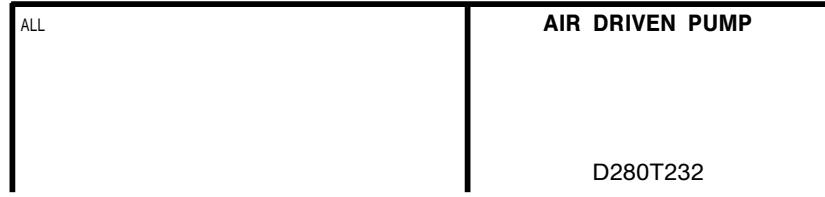
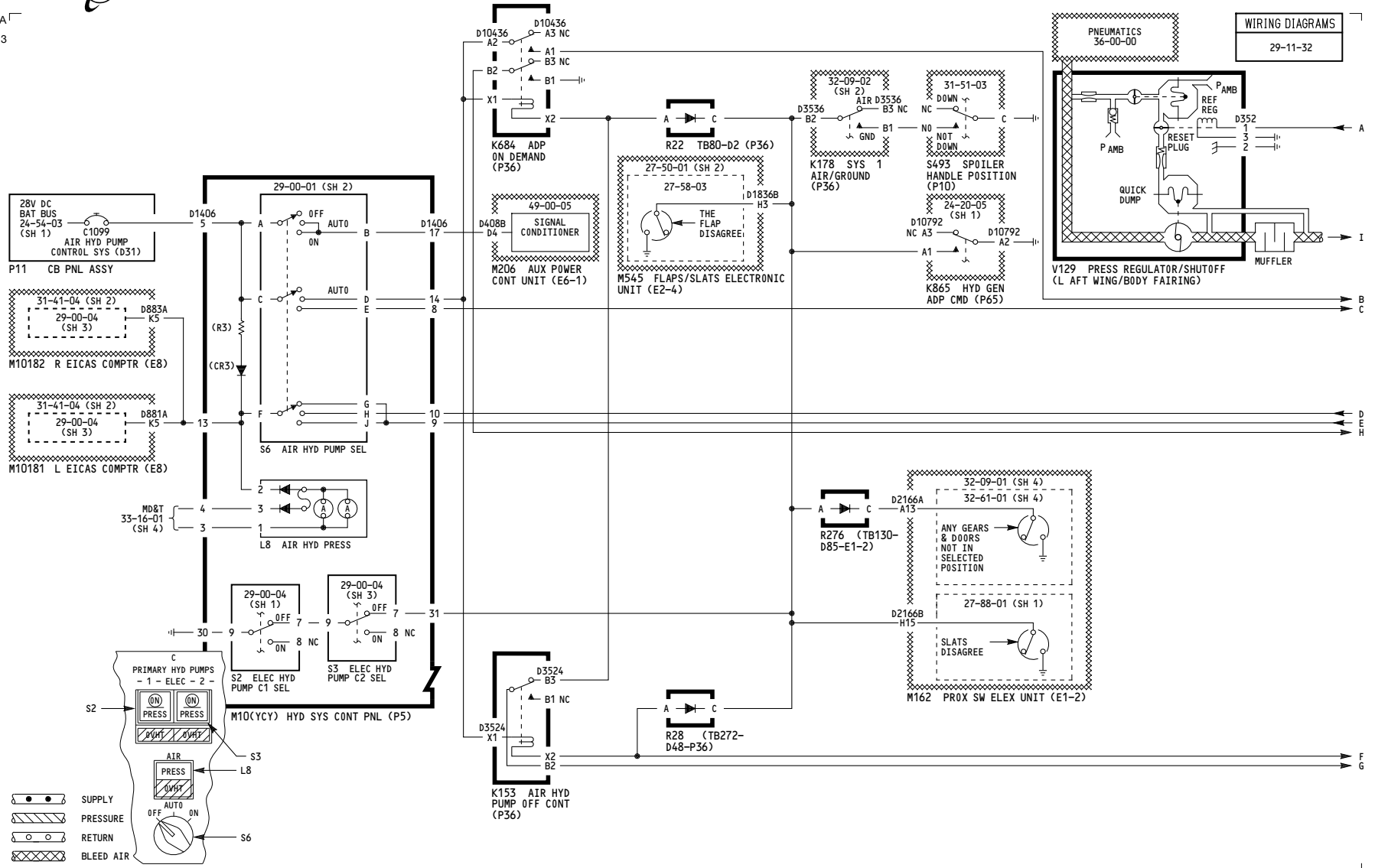

29-00-05

Page 101
Sheet 1
Feb 06/2009

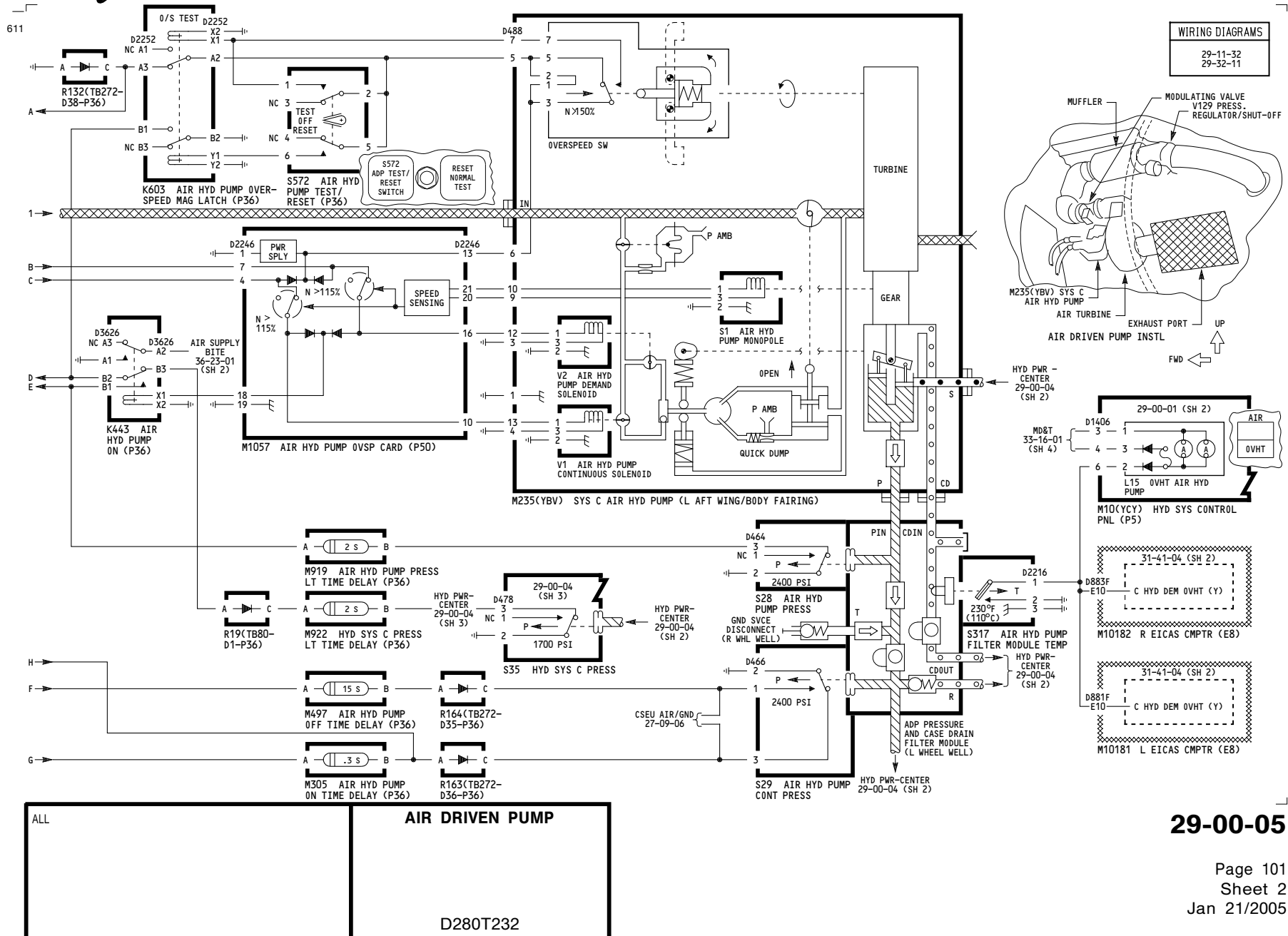

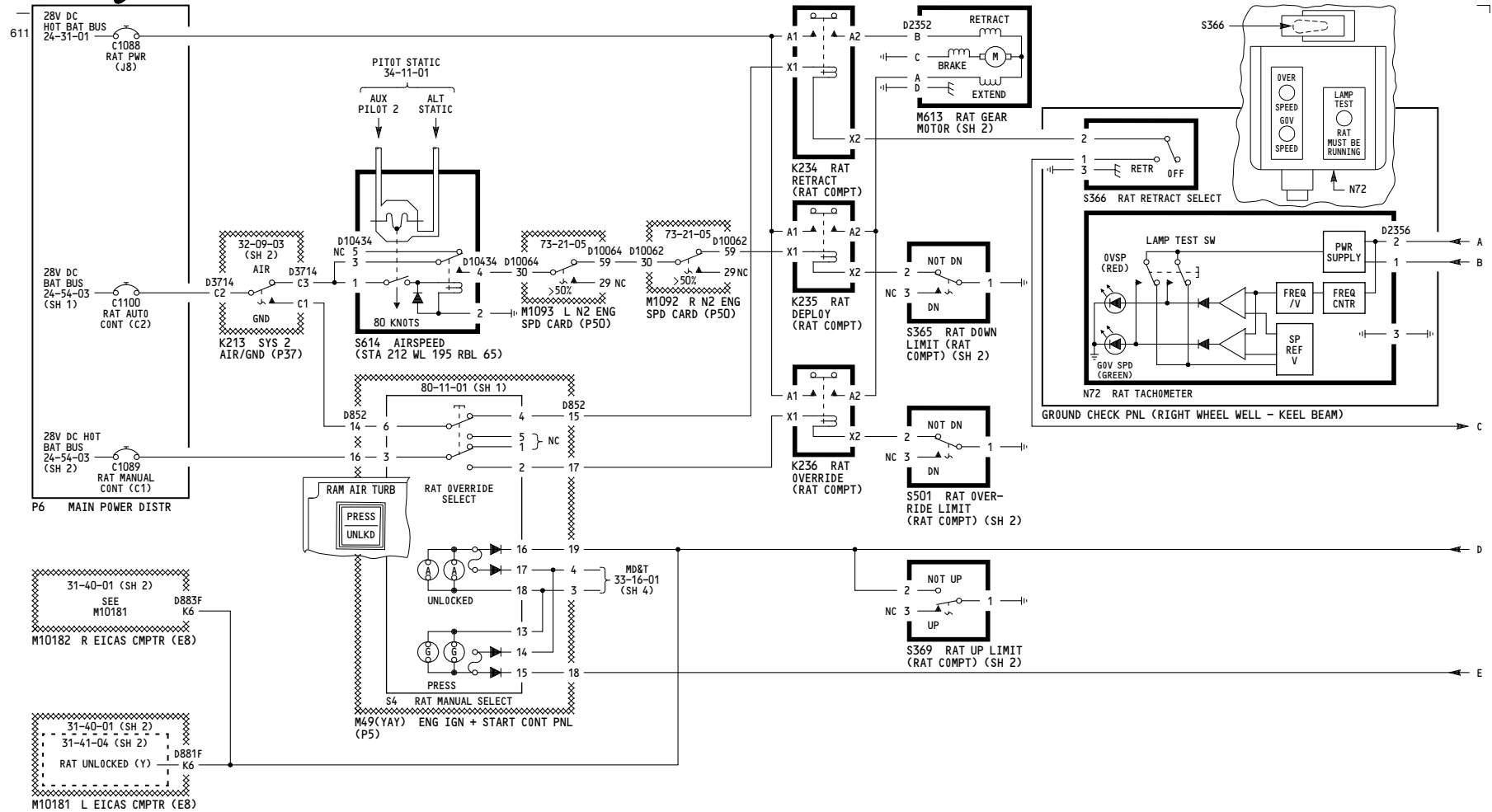

ALL	<p align="center">RAM AIR TURBINE</p> <p align="center">D280T232</p>
-----	---

29-00-06

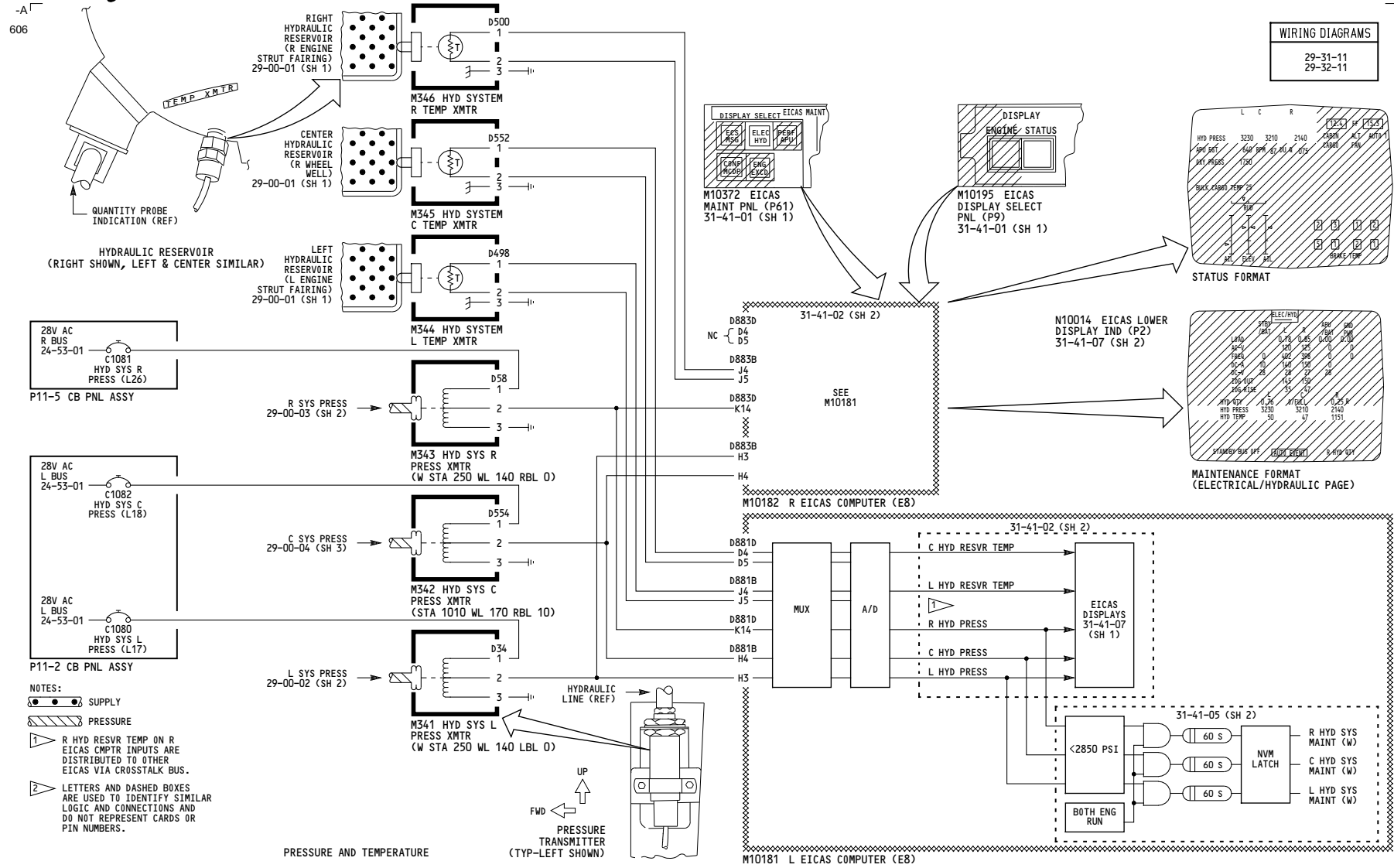

ALL

HYDRAULICS ENGINE IND AND CREW ALERTING SYSTEM INDICATION

D280T232

29-00-07

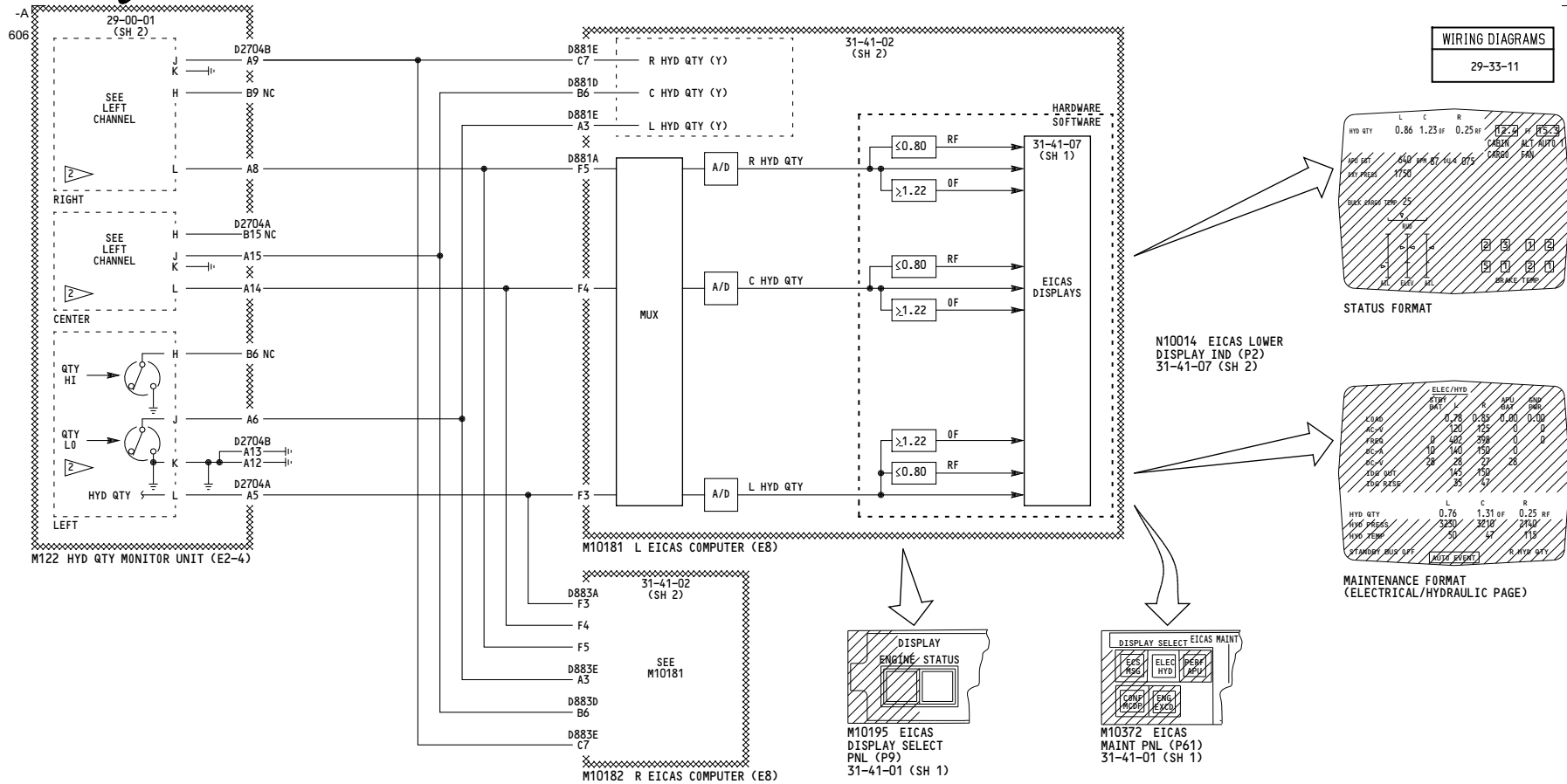

-B
605

WIRING DIAGRAMS
29-11-14

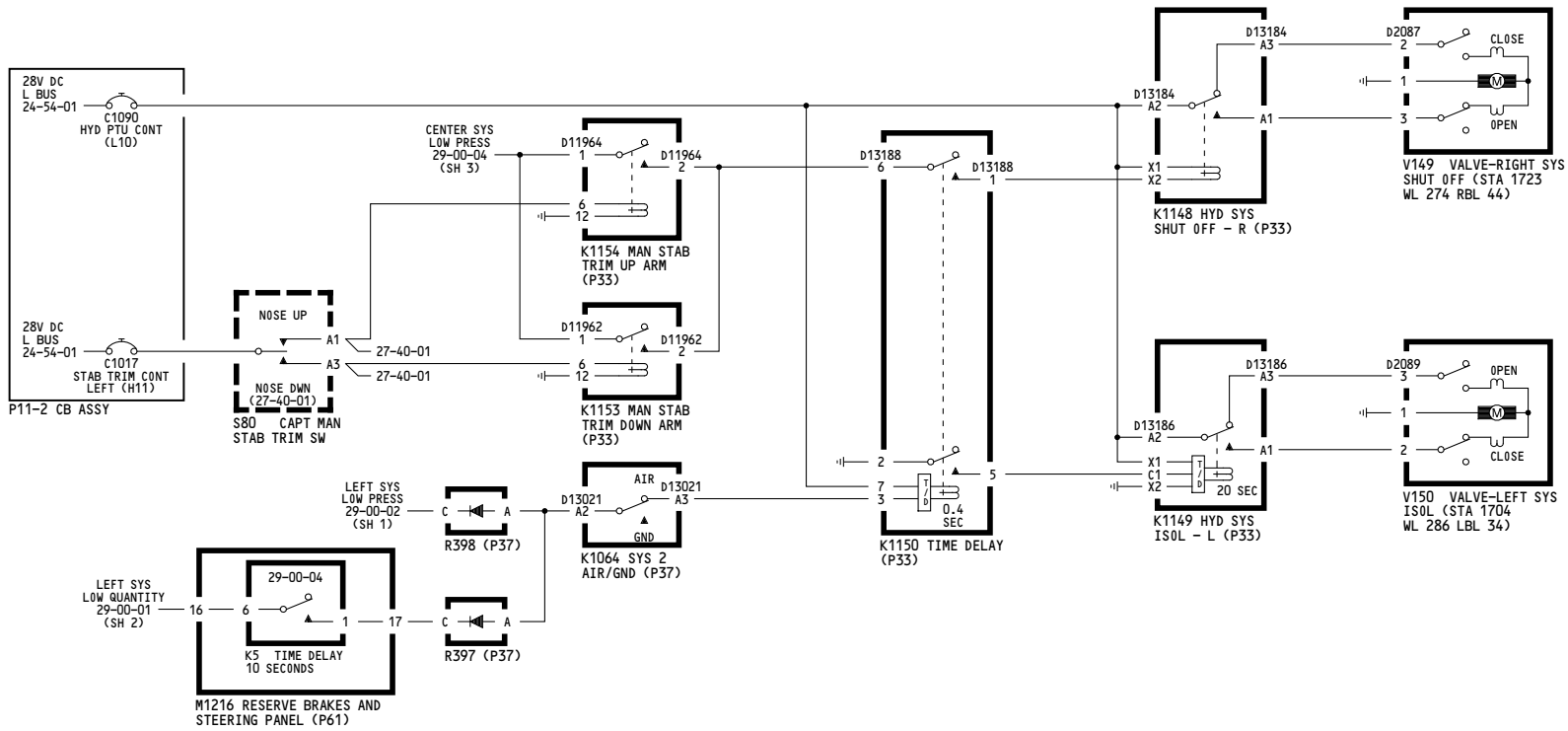

ALL	<p>POWER TRANSFER UNIT CONTROL</p> <p>D280T232</p>
-----	---

29-00-08

Page 101

Jan 21/2005