

CHAPTER

35

OXYGEN



CHAPTER 35
OXYGEN

CH-SC-SU	Schem	Page	Sheet	Date	CH-SC-SU	Schem	Page	Sheet	Date
35-EFFECTIVE PAGES									
		1		Aug 05/2009					
		2		BLANK					
35-CONTENTS									
		1		Jun 28/2006					
		2		BLANK					
35-ALPHABETICAL INDEX									
		1		Jun 28/2006					
		2		BLANK					
35-11-01									
		101		Jan 21/2005					
		102		Jan 21/2005					
35-21-01									
		101	1	Jan 21/2005					
			2	Jan 21/2005					
		102	1	Jan 21/2005					
			2	Jan 21/2005					
		103	1	Jan 21/2005					
			2	Jan 21/2005					
		104	1	Jan 21/2005					
			2	Jan 21/2005					
		105	1	Jan 21/2005					
			2	Jan 21/2005					

A = Added, R = Revised, D = Deleted, O = Overflow

35-EFFECTIVE PAGES



CHAPTER 35
OXYGEN

Title	CH-SC-SU	Schem	Page	Sheet	Date	Effectivity
<u>CREW OXYGEN SYSTEM</u>						
CREW OXYGEN	35-11-01		101		Jan 21/2005	050-099 150-199 275-278
			102		Jan 21/2005	280-299
<u>PASSENGER OXYGEN SYSTEM</u>						
PASSENGER OXYGEN	35-21-01		101	1	Jan 21/2005	050-099
				2	Jan 21/2005	050-099
			102	1	Jan 21/2005	150-157
				2	Jan 21/2005	150-157
			103	1	Jan 21/2005	162-199
				2	Jan 21/2005	162-199
			104	1	Jan 21/2005	275-278
				2	Jan 21/2005	275-278
			105	1	Jan 21/2005	280-299
				2	Jan 21/2005	280-299

CHAPTER 35
OXYGEN

CH-SC-SU	Title
35-11-01	CREW OXYGEN
35-21-01	PASSENGER OXYGEN

CH-SC-SU	Title
----------	-------

35-ALPHABETICAL INDEX

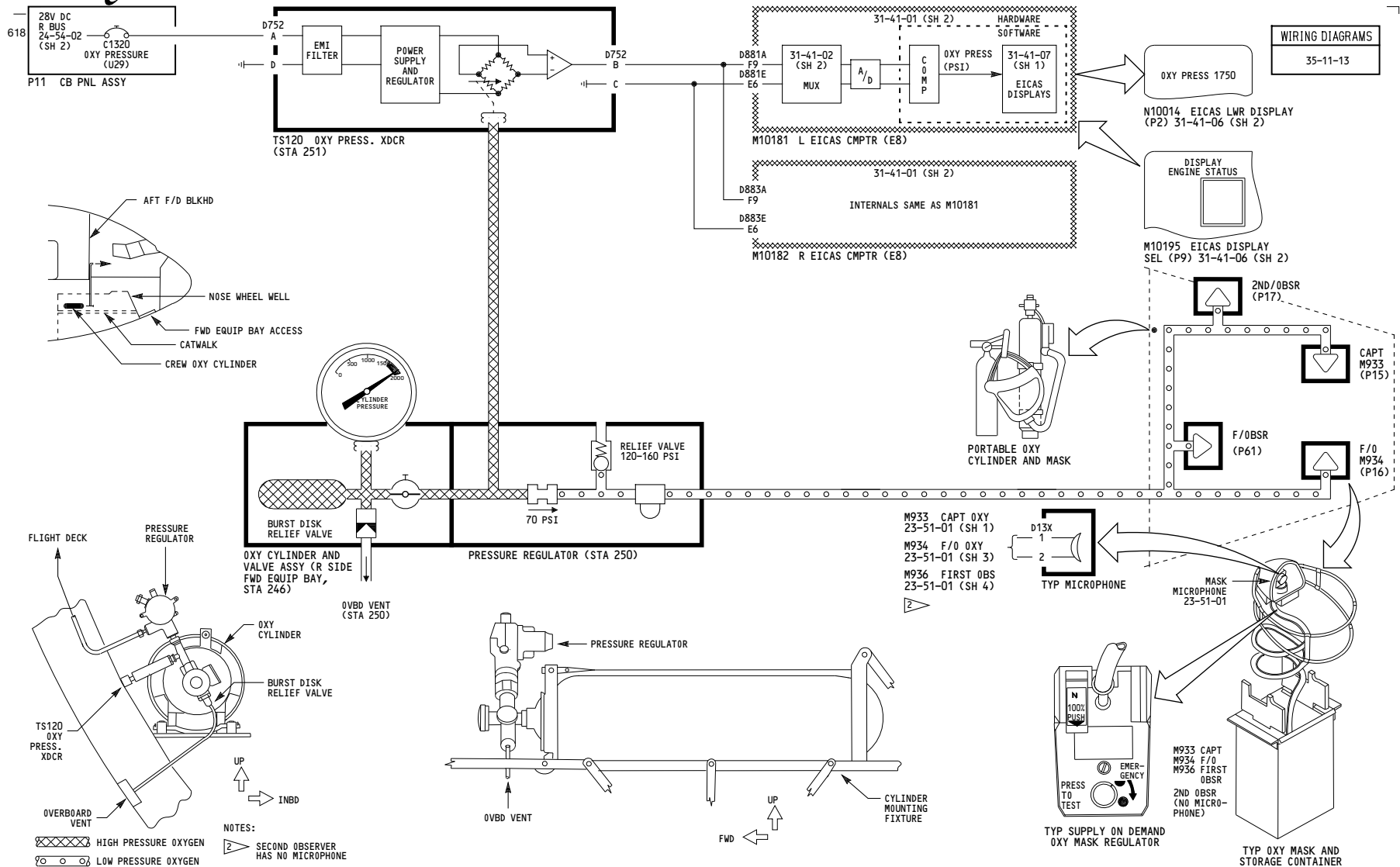

WIRING DIAGRAMS
35-11-13

050-099, 150-199, 275-278

CREW OXYGEN

D280T232

35-11-01

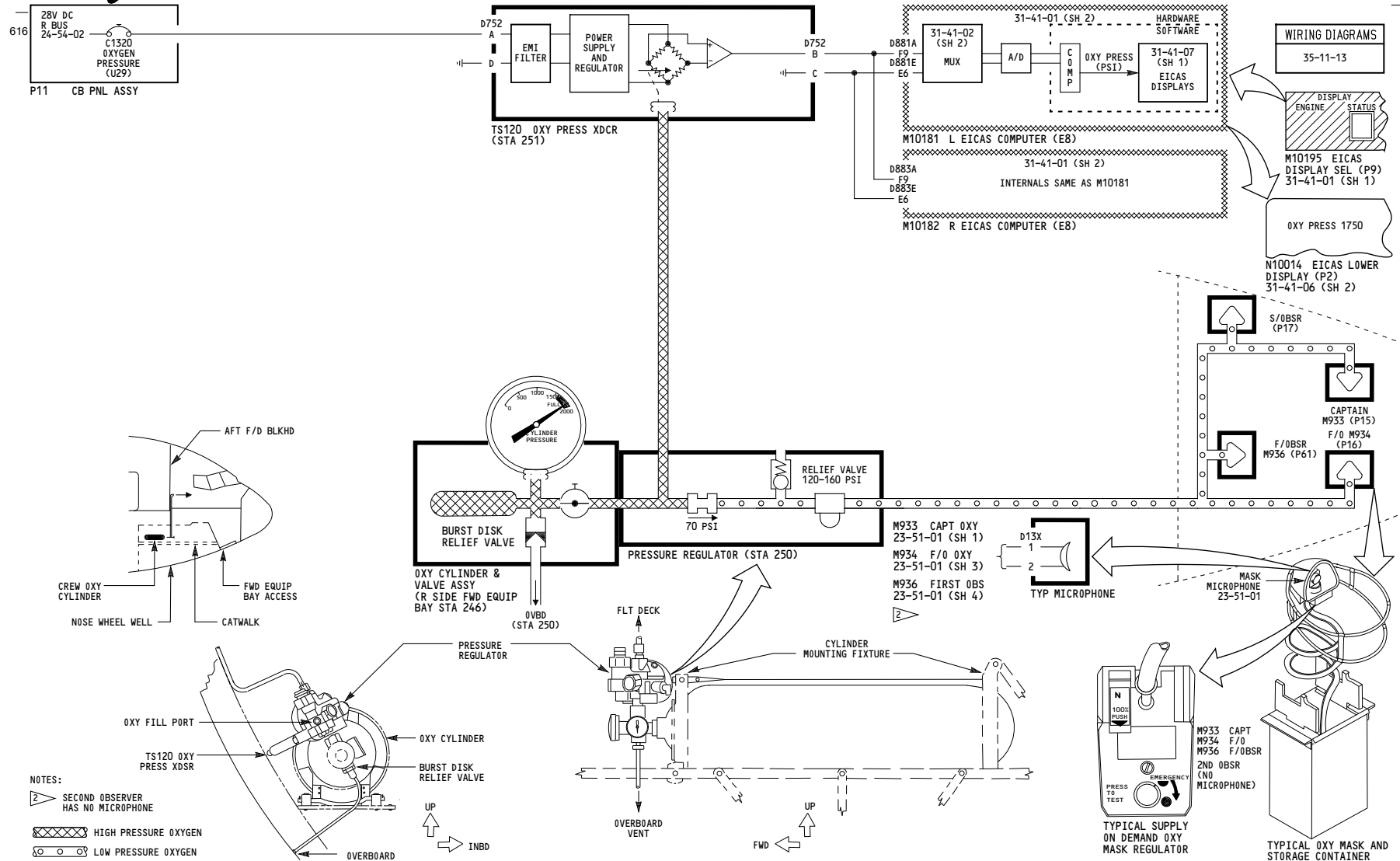

35-11-01

THIS PAGE INTENTIONALLY LEFT BLANK

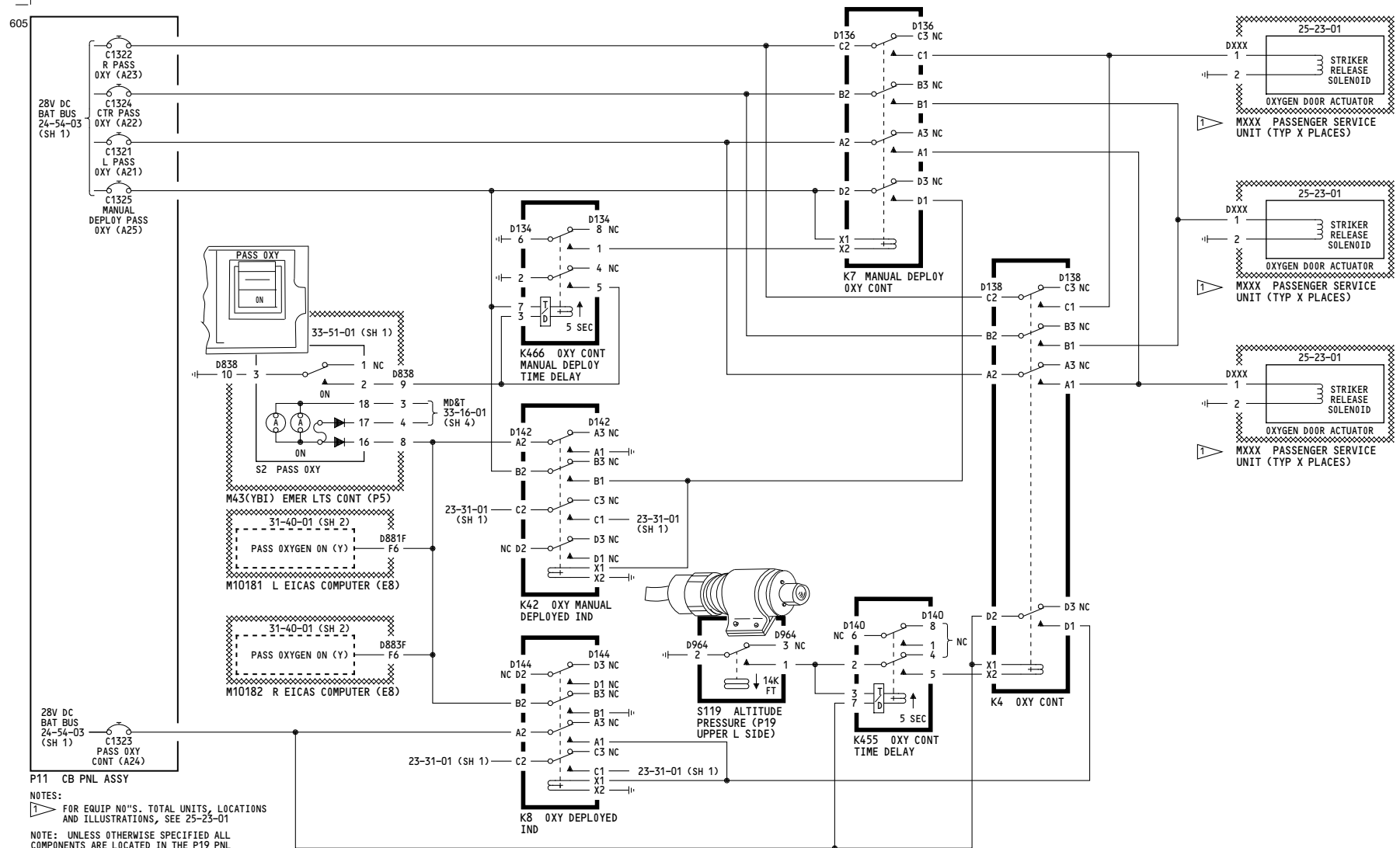

<p>050-099</p>	<p style="text-align: center;">PASSENGER OXYGEN</p> <p style="text-align: center;">D280T232</p>
----------------	--

35-21-01

647

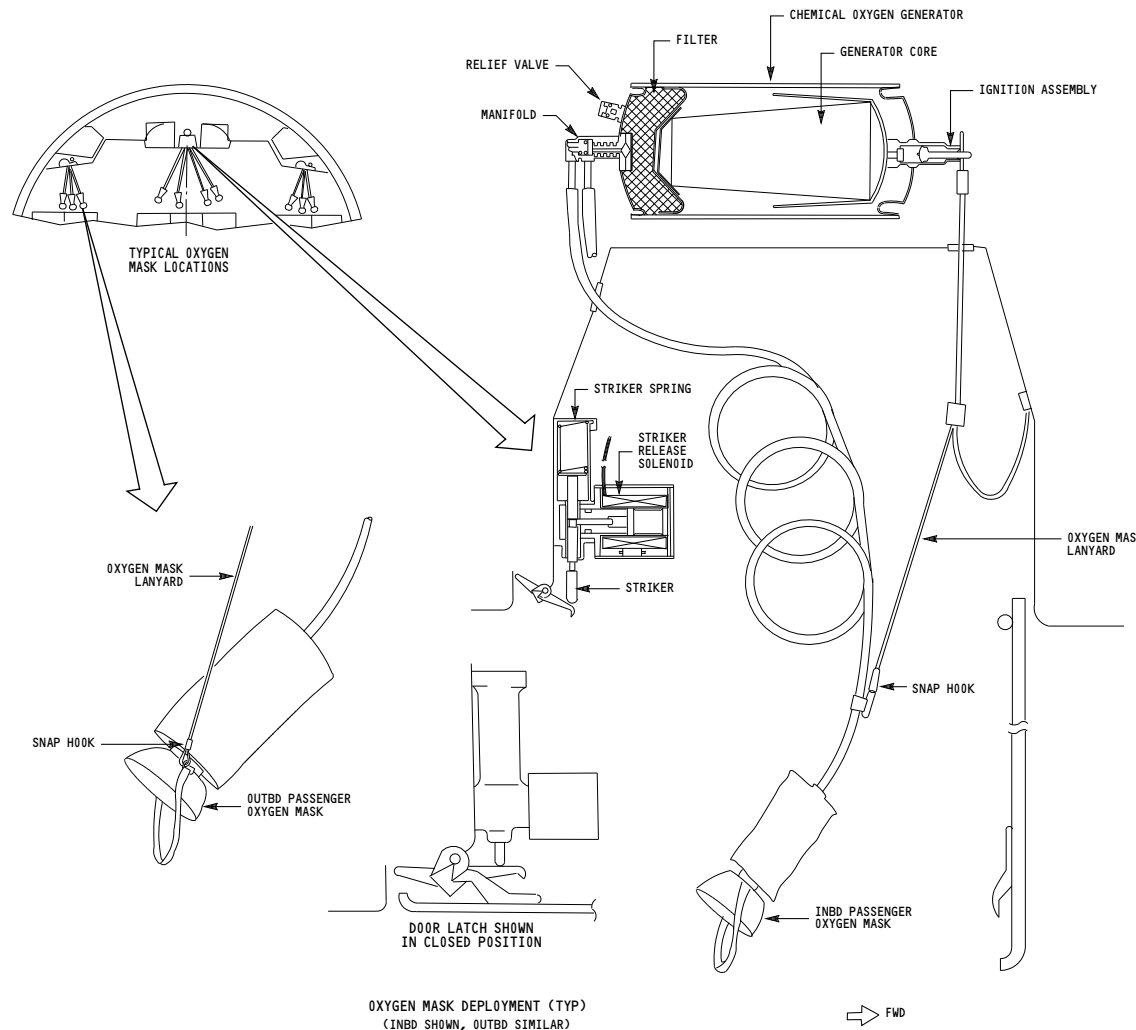

OXYGEN MASK DEPLOYMENT (TYP)
(INBD SHOWN, OUTBD SIMILAR)

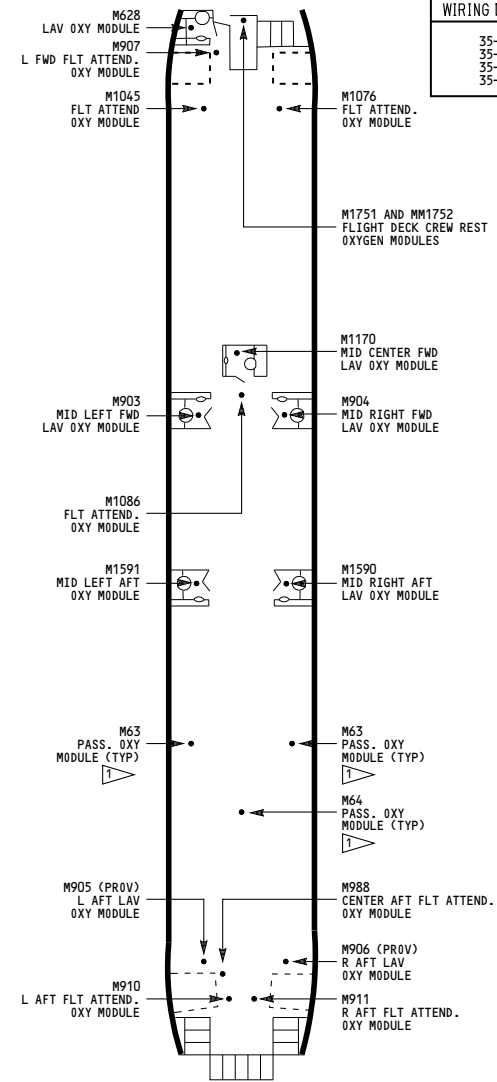

WIRING DIAGRAMS	
35-21-11	
35-21-12	
35-21-13	
35-21-14	

NOTES:
 1 FOR EQUIP NO.'S, TOTAL UNITS, LOCATIONS AND ILLUSTRATIONS, SEE 25-23-01.

050-099	PASSENGER OXYGEN
D280T232	

35-21-01

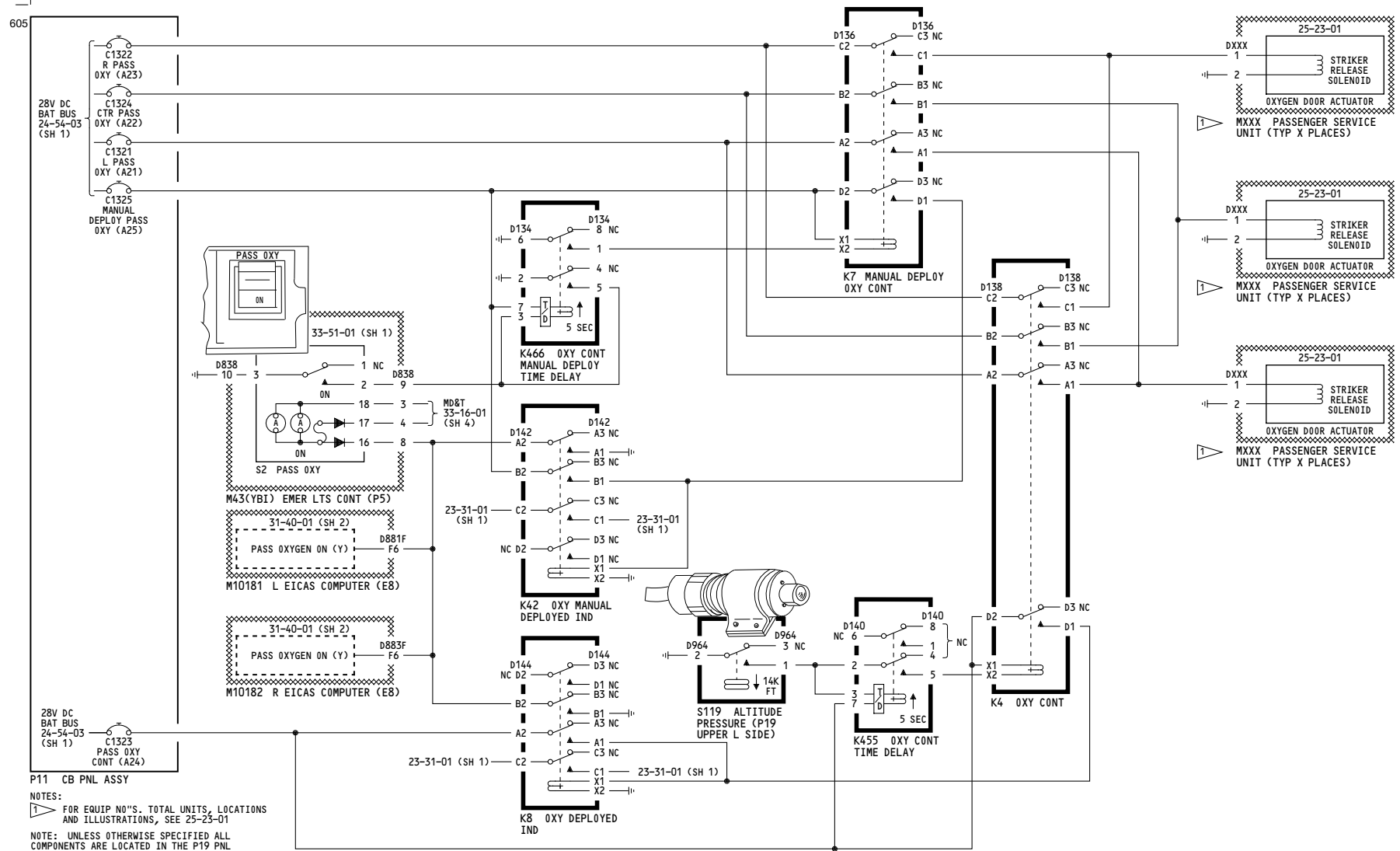

150-157

PASSENGER OXYGEN

D280T232

35-21-01

636

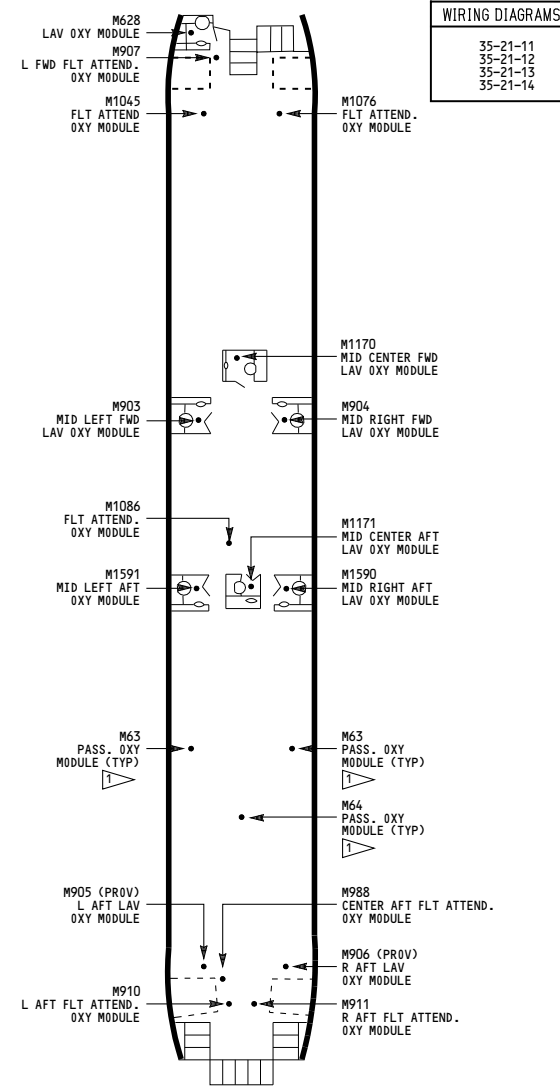
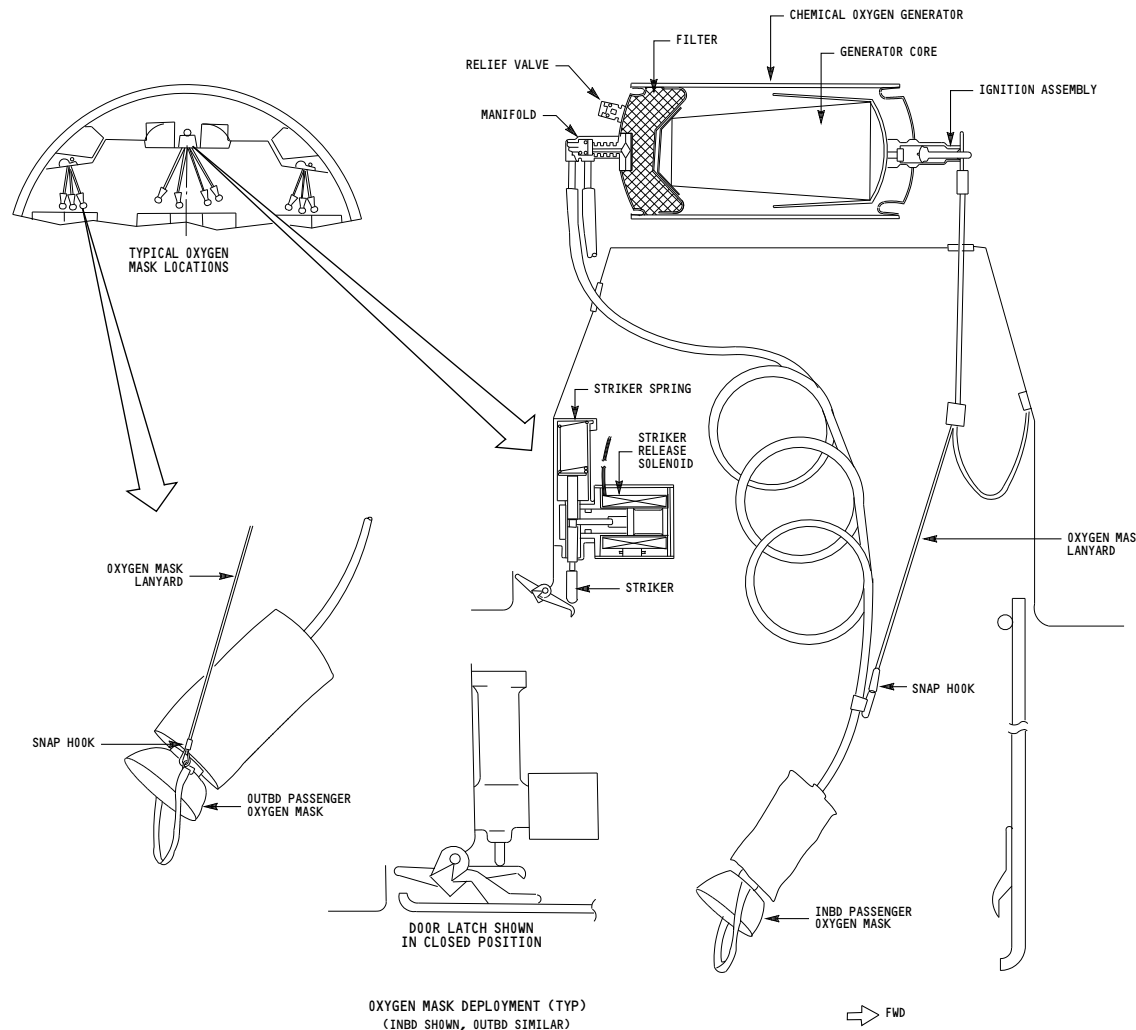

WIRING DIAGRAMS	
35-21-11	
35-21-12	
35-21-13	
35-21-14	

NOTES:
 1. FOR EQUIP NO.'S, TOTAL UNITS, LOCATIONS AND ILLUSTRATIONS, SEE 25-23-01.

150-157	PASSENGER OXYGEN
	D280T232

35-21-01

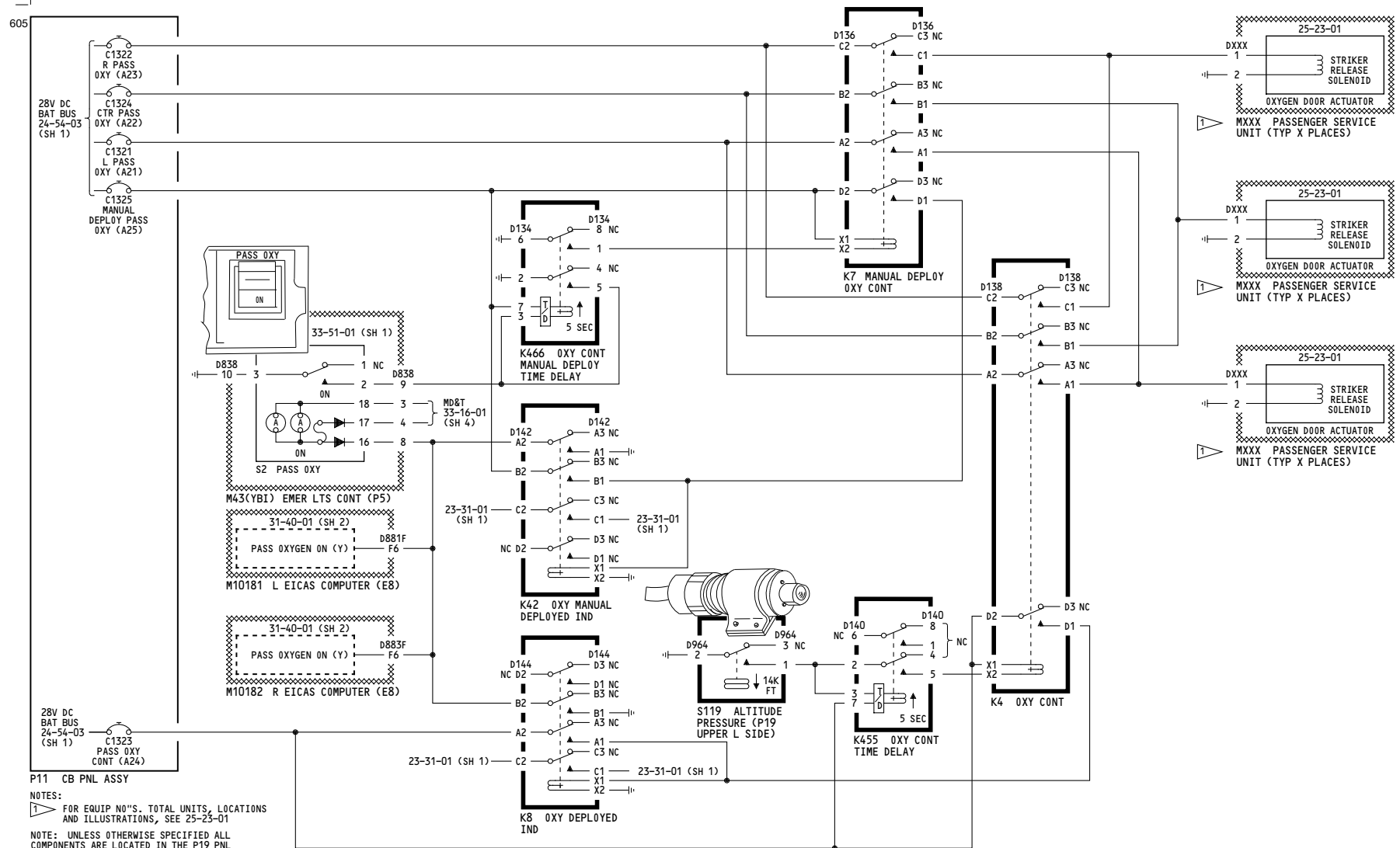

<p>162-199</p>	<p style="text-align: center;">PASSENGER OXYGEN</p> <p style="text-align: center;">D280T232</p>
----------------	--

35-21-01

650

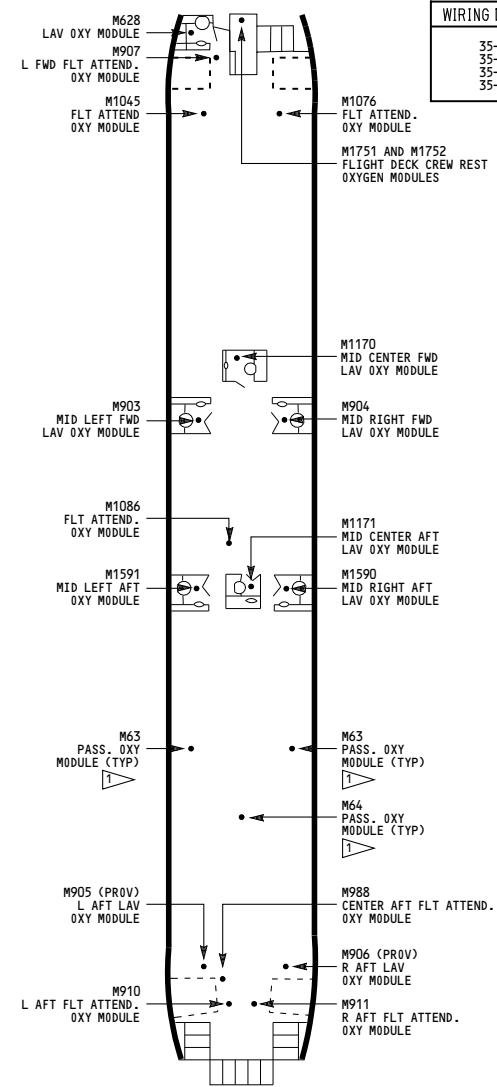
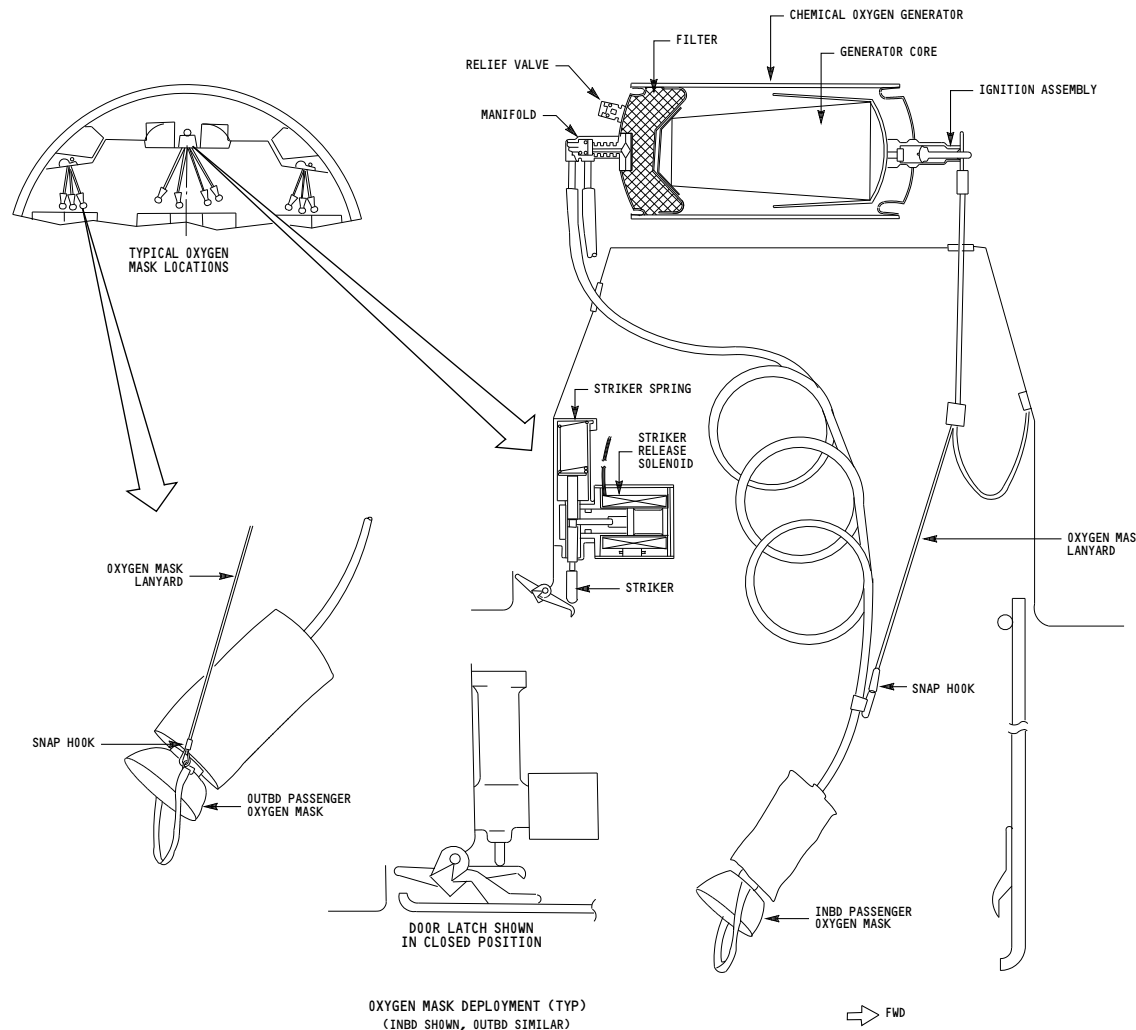

WIRING DIAGRAMS	
35-21-11	
35-21-12	
35-21-13	
35-21-14	

NOTES:
 1. FOR EQUIP NO.'S, TOTAL UNITS, LOCATIONS AND ILLUSTRATIONS, SEE 25-23-01.

162-199	PASSENGER OXYGEN
	D280T232

35-21-01

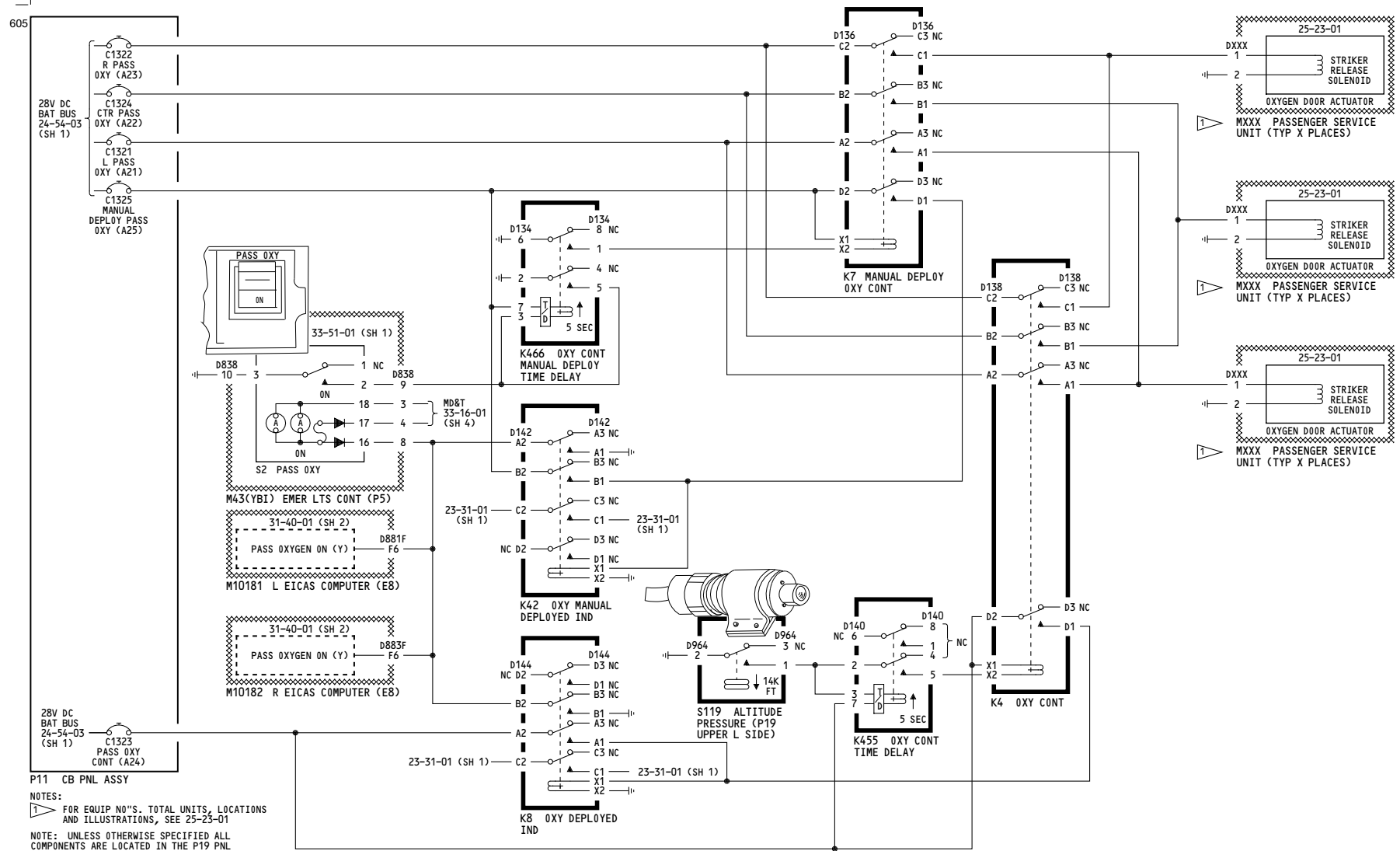

275-278

PASSENGER OXYGEN

D280T232

35-21-01

Page 104
Sheet 1
Jan 21/2005

642

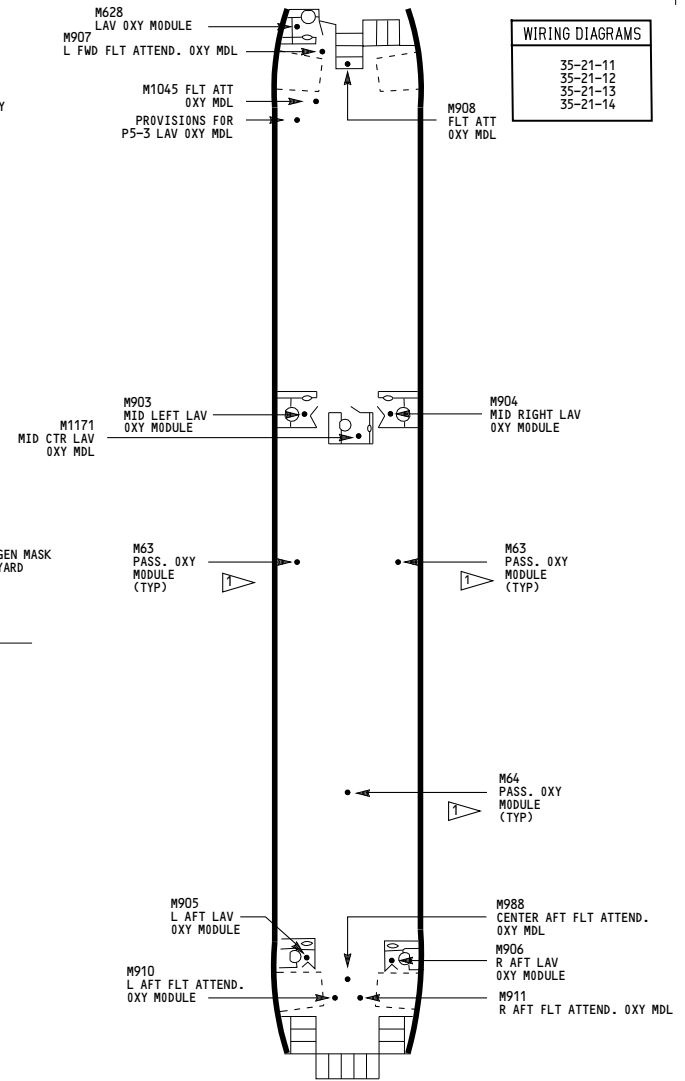
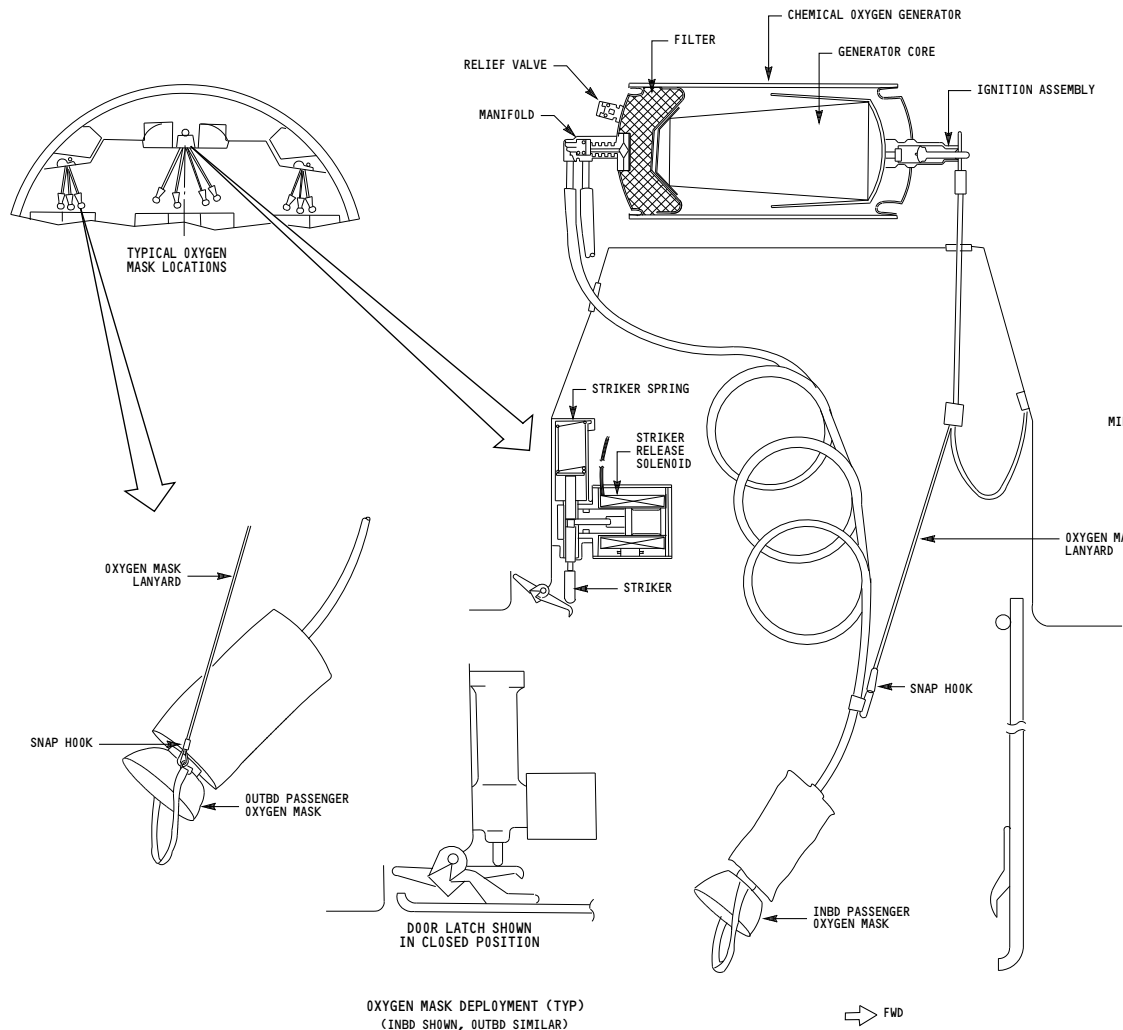

NOTES:
 1 FOR EQUIP NO.'S, TOTAL UNITS, LOCATIONS AND ILLUSTRATIONS, SEE 25-23-01.

275-278	PASSENGER OXYGEN
	D280T232

35-21-01

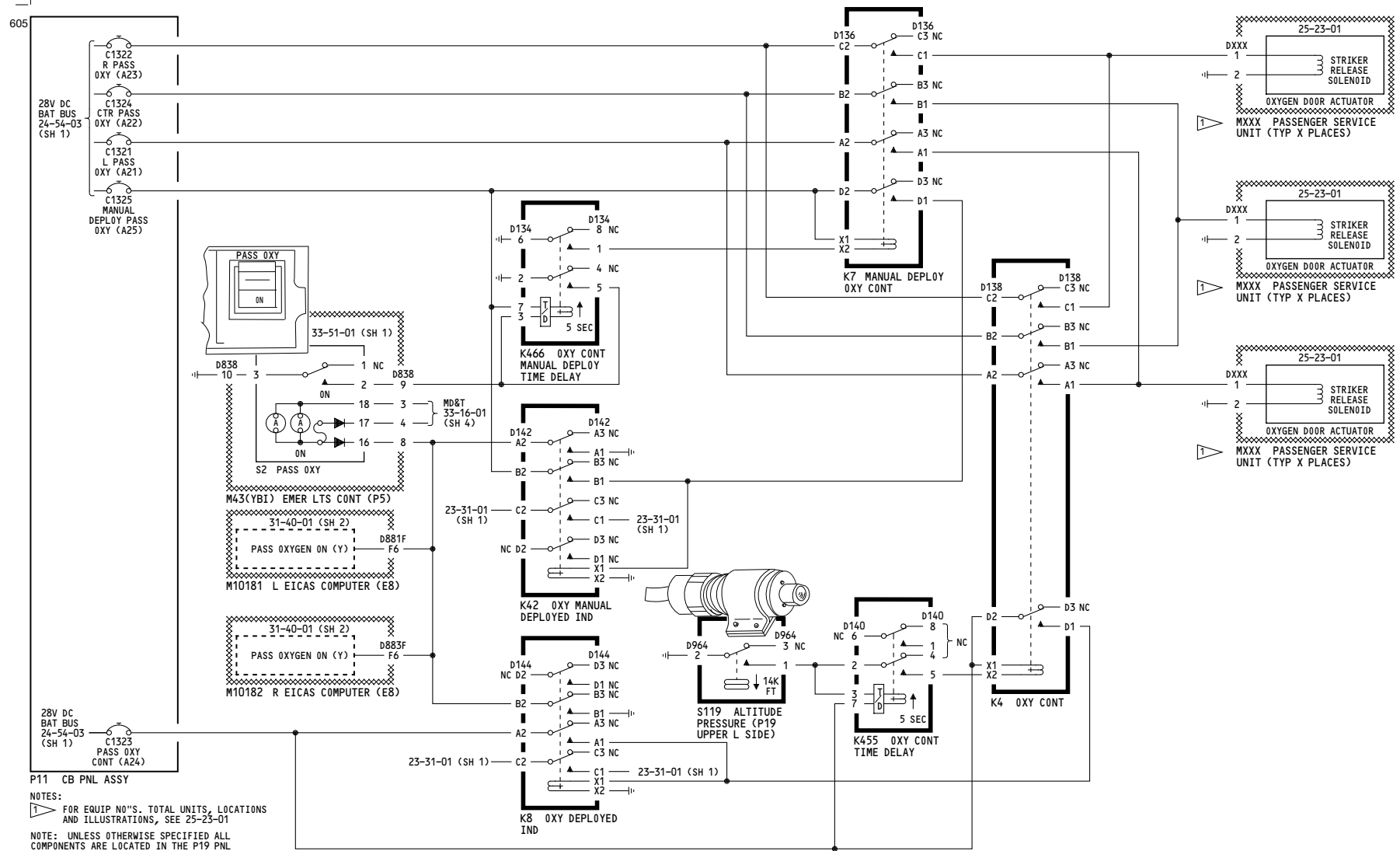

280-299

PASSENGER OXYGEN

D280T232

35-21-01

Page 105
Sheet 1
Jan 21/2005

662

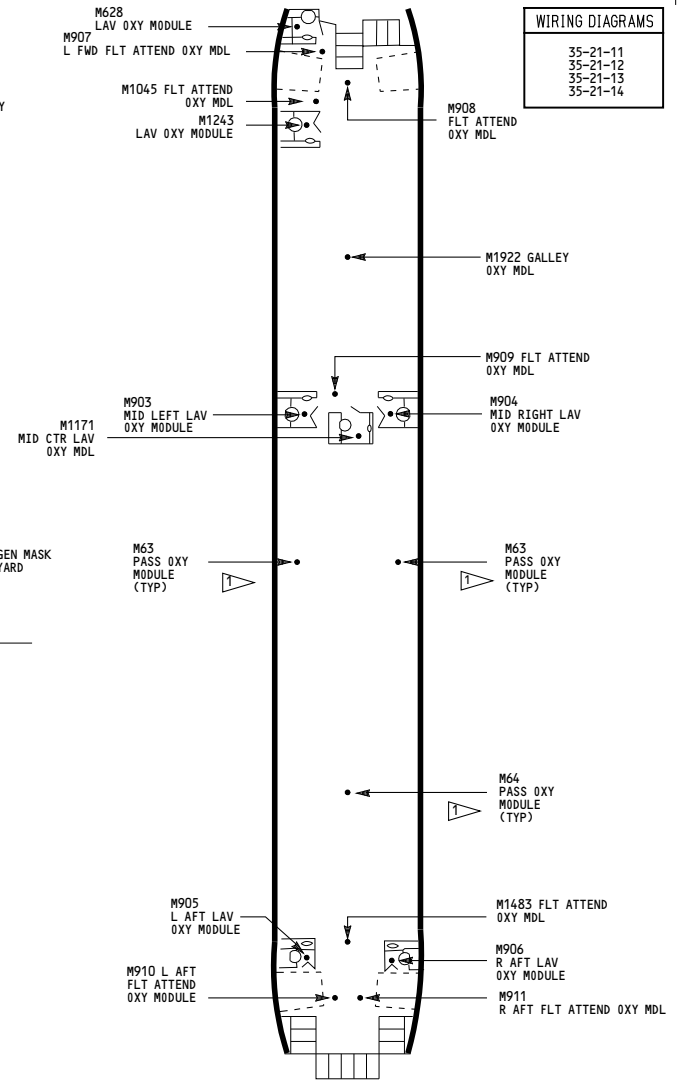
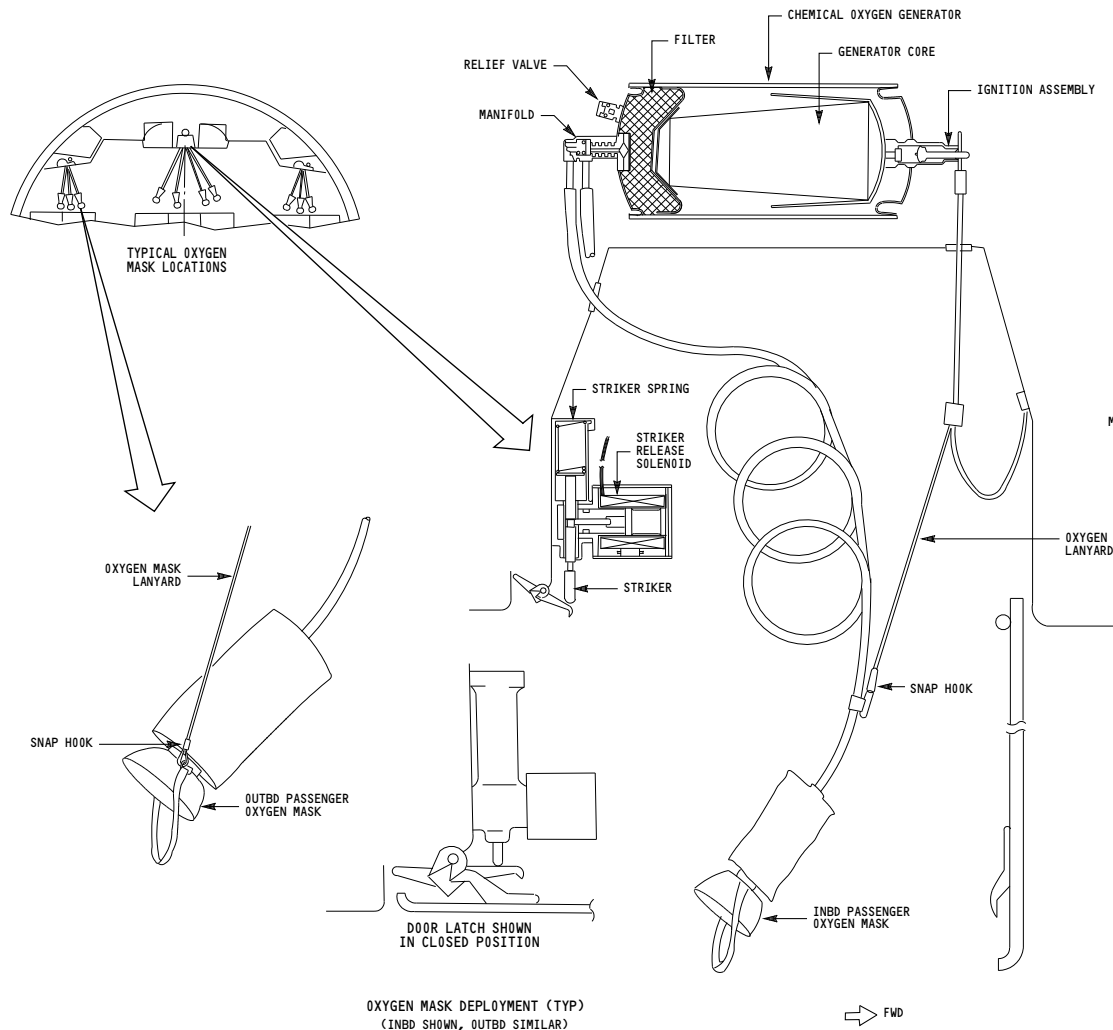

NOTES:
 1 FOR EQUIP NO.'S, TOTAL UNITS, LOCATIONS AND ILLUSTRATIONS, SEE 25-23-01.

280-299	PASSENGER OXYGEN
	D280T232

35-21-01