

CHAPTER

77

ENGINE INDICATING



CHAPTER 77
ENGINE INDICATING

CH-SC-SU	Schem	Page	Sheet	Date	CH-SC-SU	Schem	Page	Sheet	Date
77-EFFECTIVE PAGES					77-31-01				
		1		Aug 05/2009			101		Jan 21/2005
		2		BLANK			102.1		Jan 21/2005
77-CONTENTS							103		Jan 21/2005
		1		Feb 06/2009	77-35-01				
		2		Feb 06/2009			101	1	Mar 14/2007
77-ALPHABETICAL INDEX								2	Mar 14/2007
		1		Jun 28/2006			102	1	Jan 21/2005
		2		BLANK				2	Mar 14/2007
77-00-01							102.1	1	Mar 14/2007
		101.1	1	Jan 21/2005				2	Mar 14/2007
			2	Jan 21/2005					
		101.2	1	Feb 06/2009					
			2	Feb 06/2009					
		102.1	1	Jan 21/2005					
			2	Jan 21/2005					
		102.2	1	Feb 06/2009					
			2	Feb 06/2009					
		103	1	Jan 21/2005					
			2	Jan 21/2005					
		104.1	1	Jan 21/2005					
			2	Jan 21/2005					
77-00-02									
		101		Jan 21/2005					
		101.1		Feb 06/2009					

A = Added, R = Revised, D = Deleted, O = Overflow

77-EFFECTIVE PAGES

Page 1
Aug 05/2009

D280T232



CHAPTER 77
ENGINE INDICATING

Title	CH-SC-SU	Schem	Page	Sheet	Date	Effectivity	
<u>ENGINE INDICATING</u>							
ENGINE INDICATING	77-00-01		101.1	1	Jan 21/2005	050-051 162-165	
					2	Jan 21/2005	050-051 162-165
				101.2	1	Feb 06/2009	050-051 162-165
					2	Feb 06/2009	050-051 162-165
				102.1	1	Jan 21/2005	150-154
					2	Jan 21/2005	150-154
				102.2	1	Feb 06/2009	150-154
					2	Feb 06/2009	150-154
				103	1	Jan 21/2005	155-157 166-199 277-299
					2	Jan 21/2005	155-157 166-199 277-299
				104.1	1	Jan 21/2005	275-276
					2	Jan 21/2005	275-276
AIRBORNE VIBRATION MONITORING		77-00-02		101		Jan 21/2005	ALL
					101.1		Feb 06/2009
<u>AIRBORNE VIBRATION MONITORING (AVM) SYSTEM</u>							
AIRBORNE VIBRATION MONITORING	77-31-01		101		Jan 21/2005	050-099 155-157 164-199 277-299	
				102.1		Jan 21/2005	150-154
				103		Jan 21/2005	275-276
<u>ELECTRONIC PROPULSION CONTROL SYSTEM (EPCS)</u>							
ELECTRONIC ENGINE CONTROL MONITOR	77-35-01		101	1	Mar 14/2007	050-099 155-199 277-299	
					2	Mar 14/2007	050-099 155-199 277-299

**CHAPTER 77
ENGINE INDICATING**

Title	CH-SC-SU	Schem	Page	Sheet	Date	Effectivity
ELECTRONIC ENGINE CONTROL MONITOR (cont.)	77-35-01		102	1	Jan 21/2005	150-154 275-276
				2	Mar 14/2007	150-154 275-276
			102.1	1	Mar 14/2007	150-154 275-276
				2	Mar 14/2007	150-154 275-276

**CHAPTER 77
ENGINE INDICATING**

CH-SC-SU	Title
77-00-02	AIRBORNE VIBRATION MONITORING
77-31-01	AIRBORNE VIBRATION MONITORING
77-35-01	ELECTRONIC ENGINE CONTROL MONITOR
77-00-01	ENGINE INDICATING

CH-SC-SU	Title
----------	-------

77-ALPHABETICAL INDEX

THIS PAGE INTENTIONALLY LEFT BLANK

618

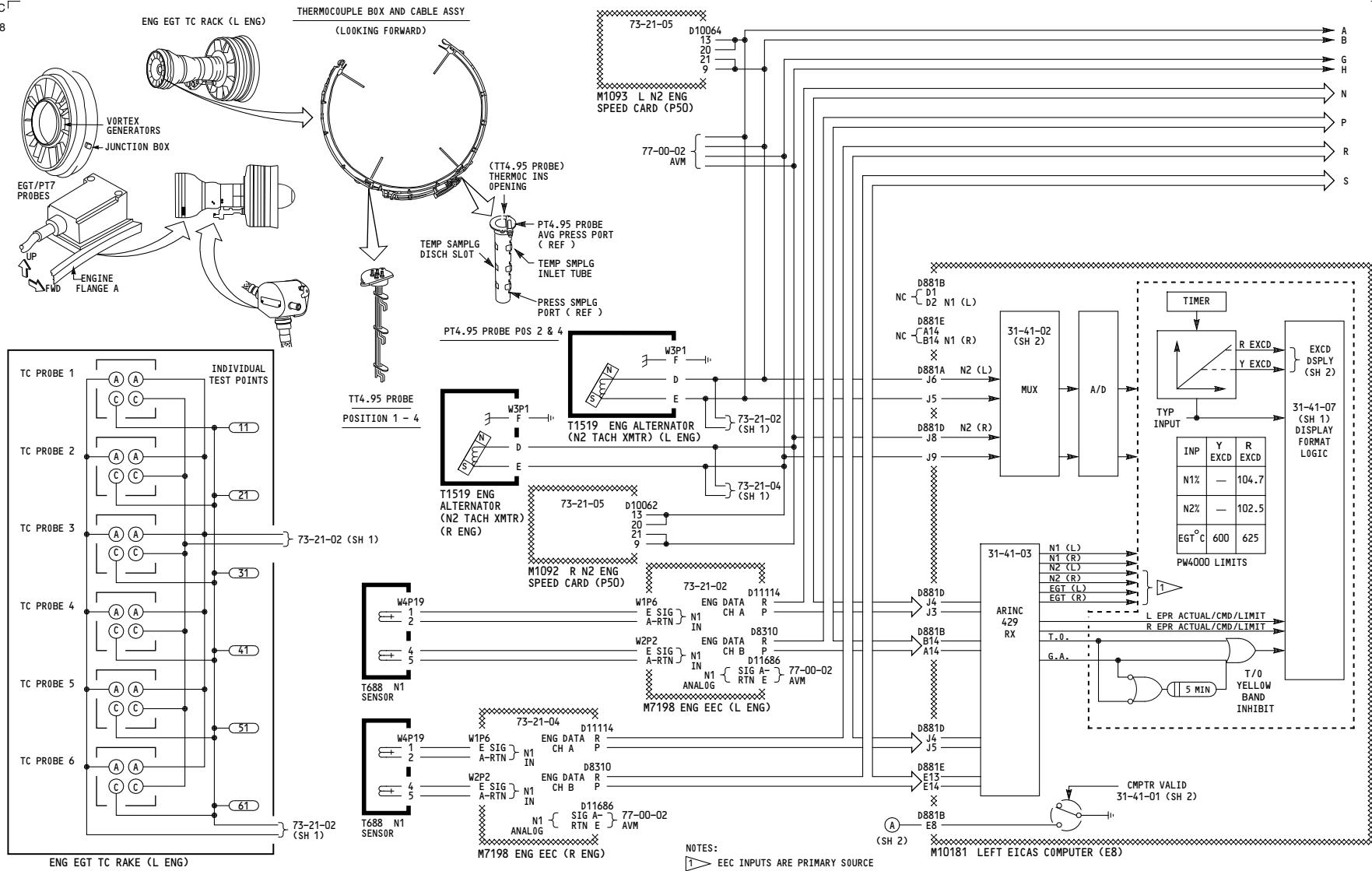

050-051, 162-165	ENGINE INDICATING
D280T232	

77-00-01

Page 101.1
Sheet 1
Jan 21/2005

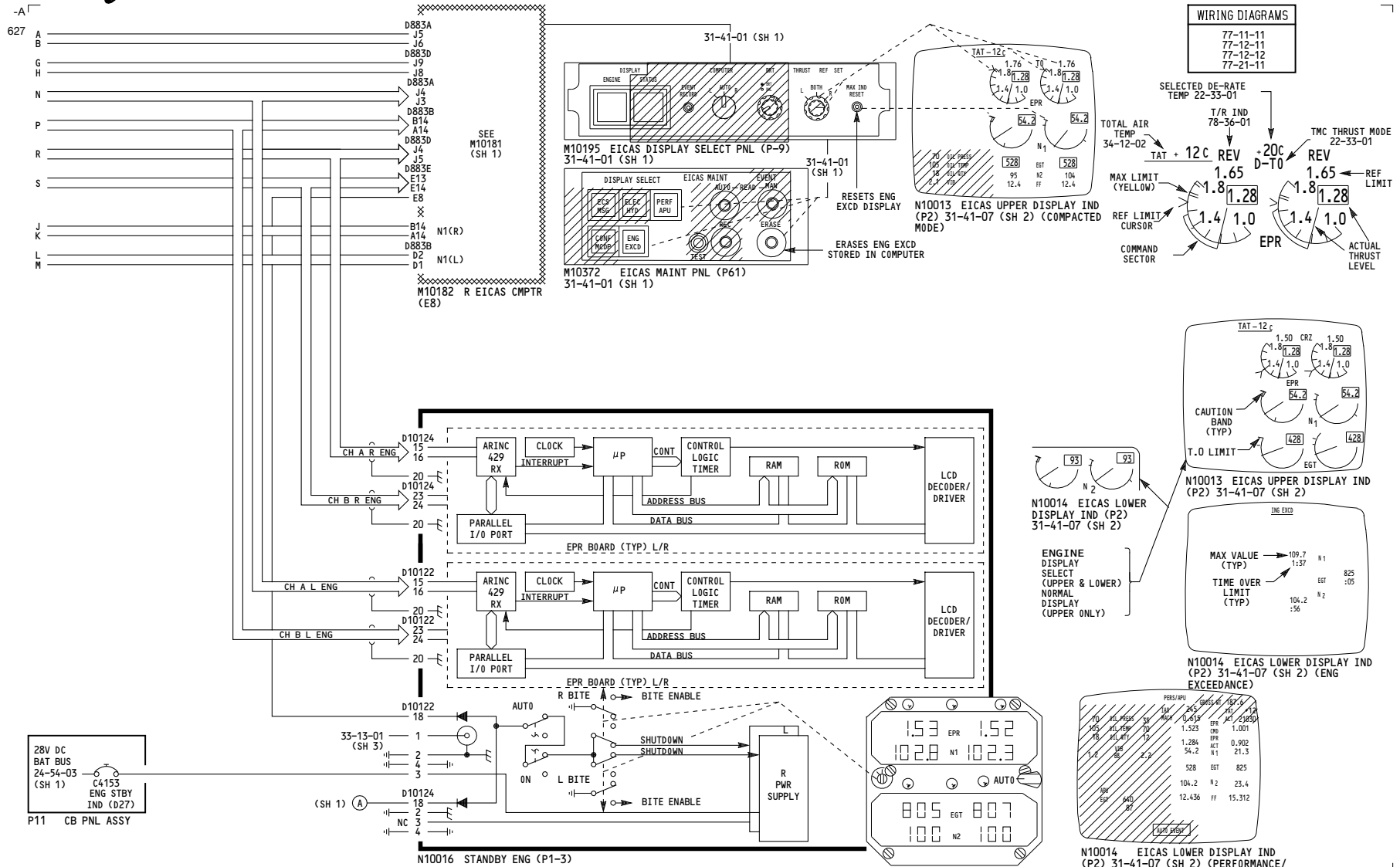

050-051, 162-165

ENGINE INDICATING

Incorporates
73-0036

D280T232

77-00-01

635

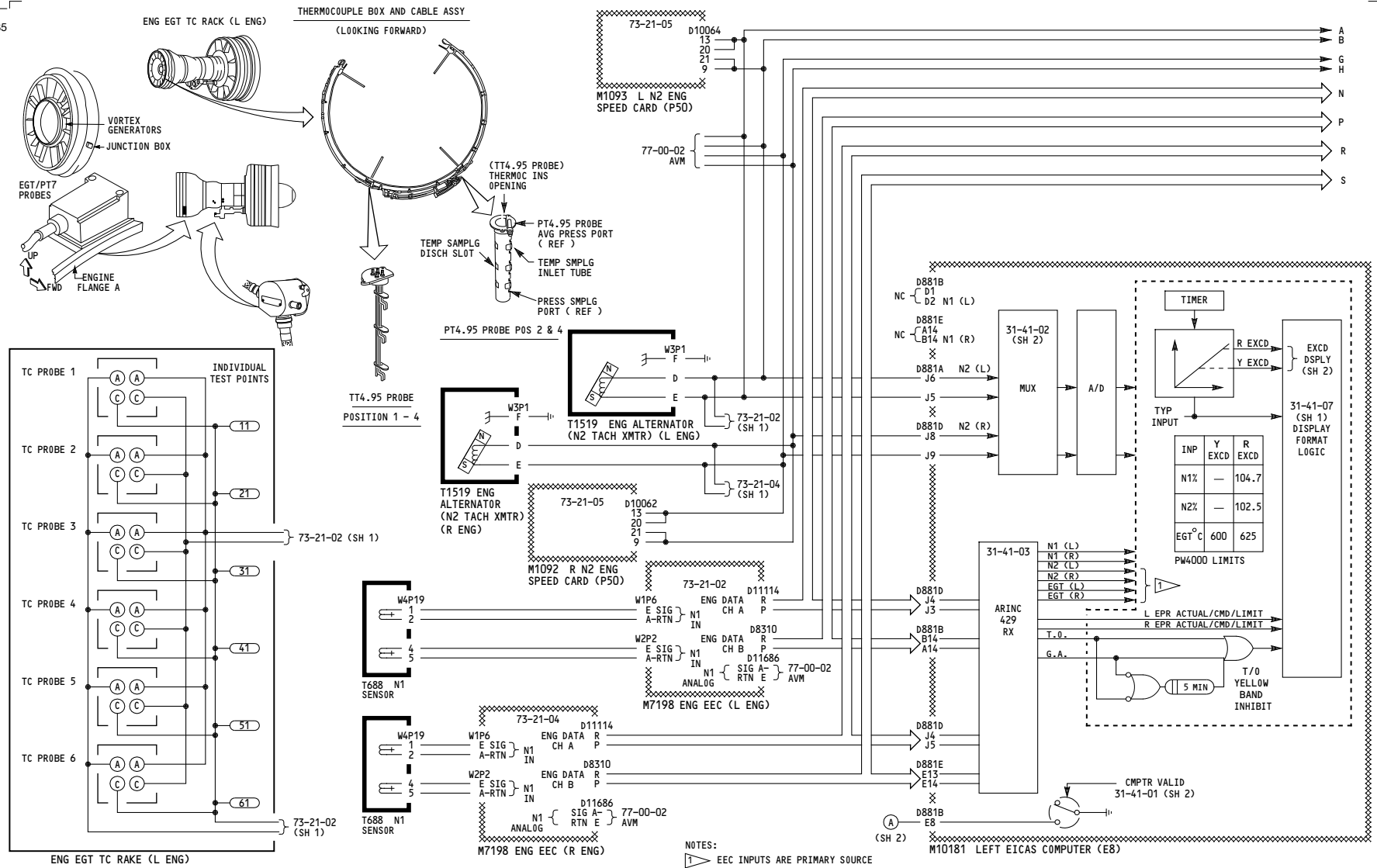

050-051, 162-165

ENGINE INDICATING

D280T232

77-00-01

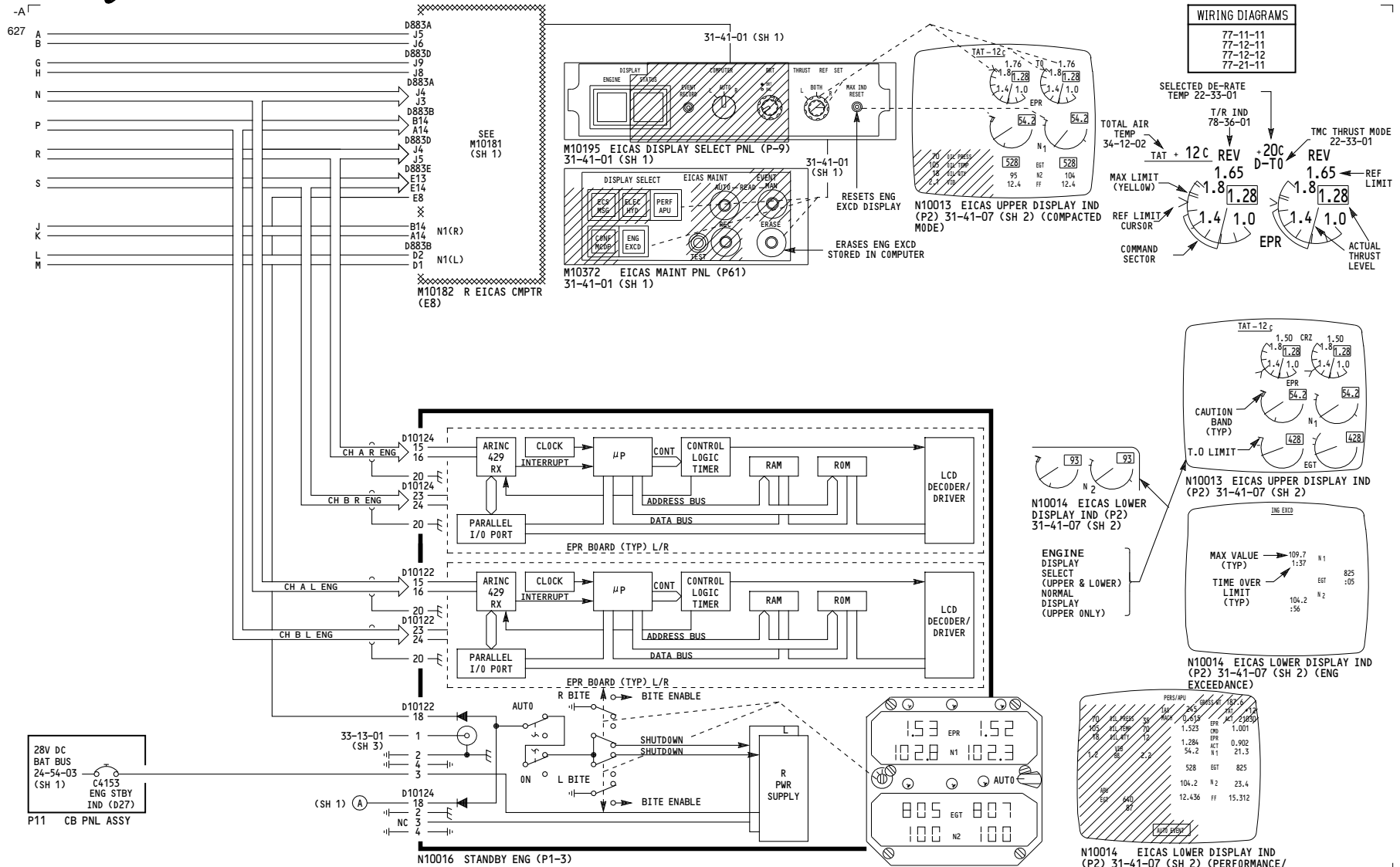

150-154

ENGINE INDICATING

Incorporates 73-0036

D280T232

77-00-01

635

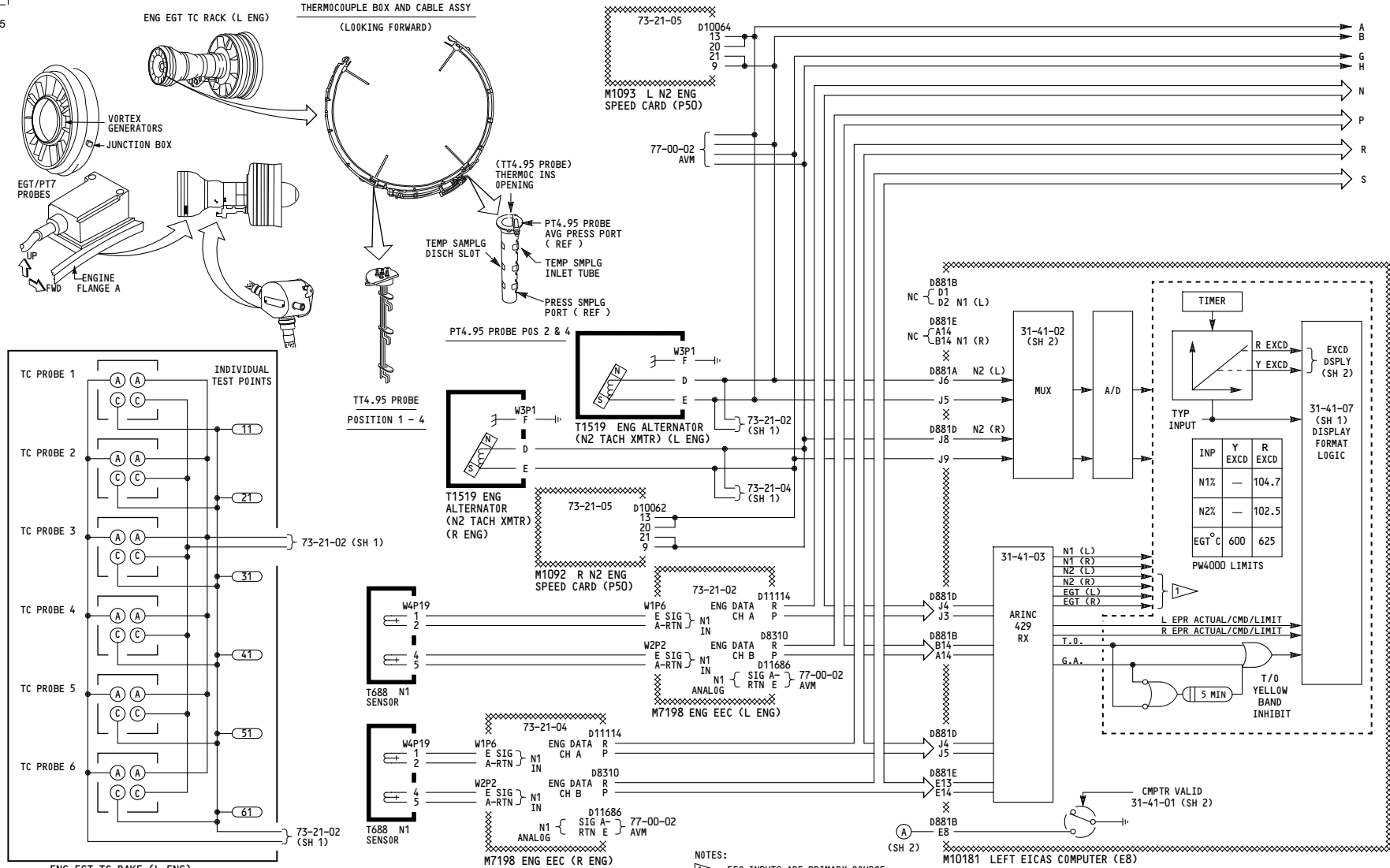

150-154

ENGINE INDICATING

D280T232

77-00-01

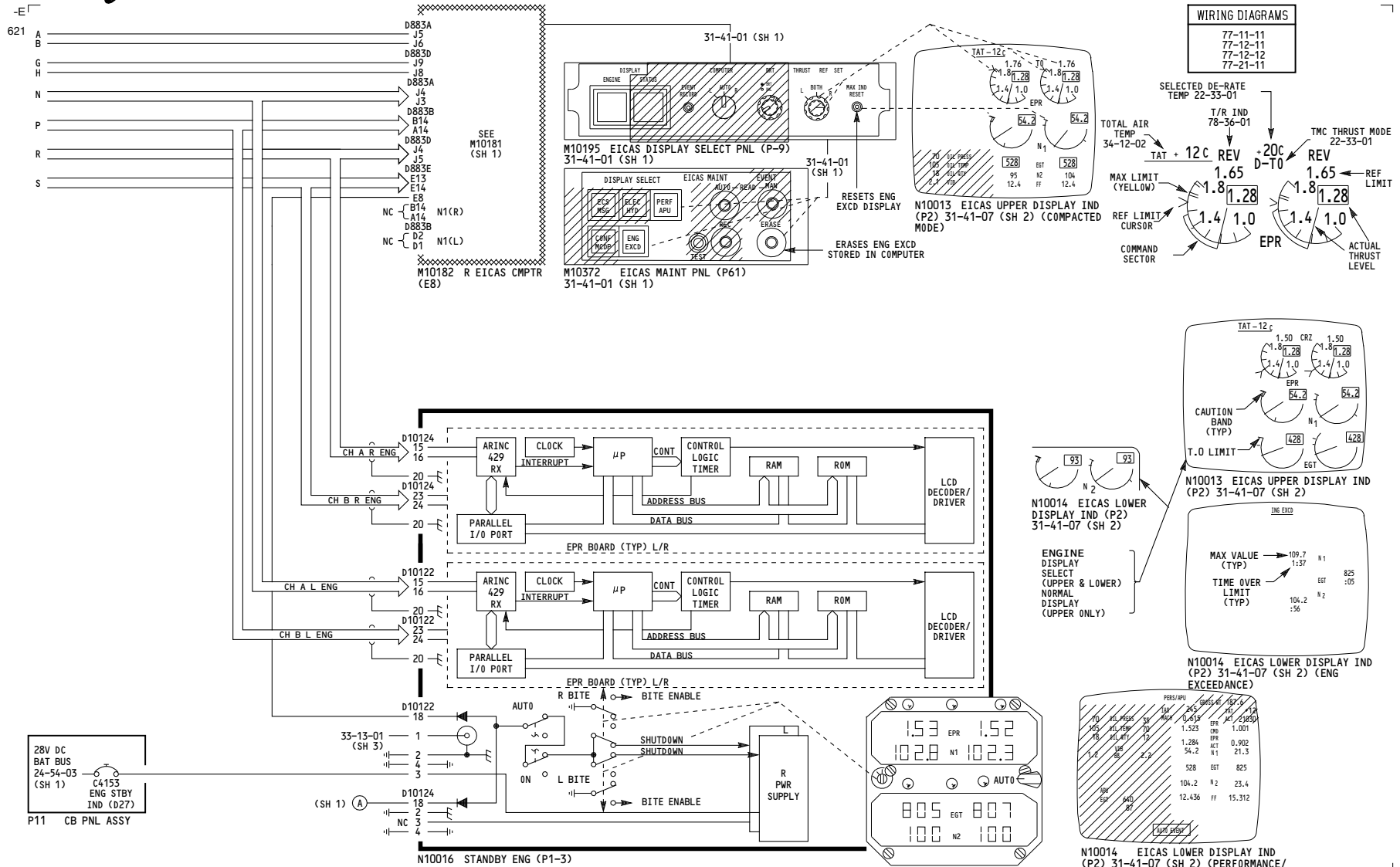

150-154

ENGINE INDICATING

D280T232

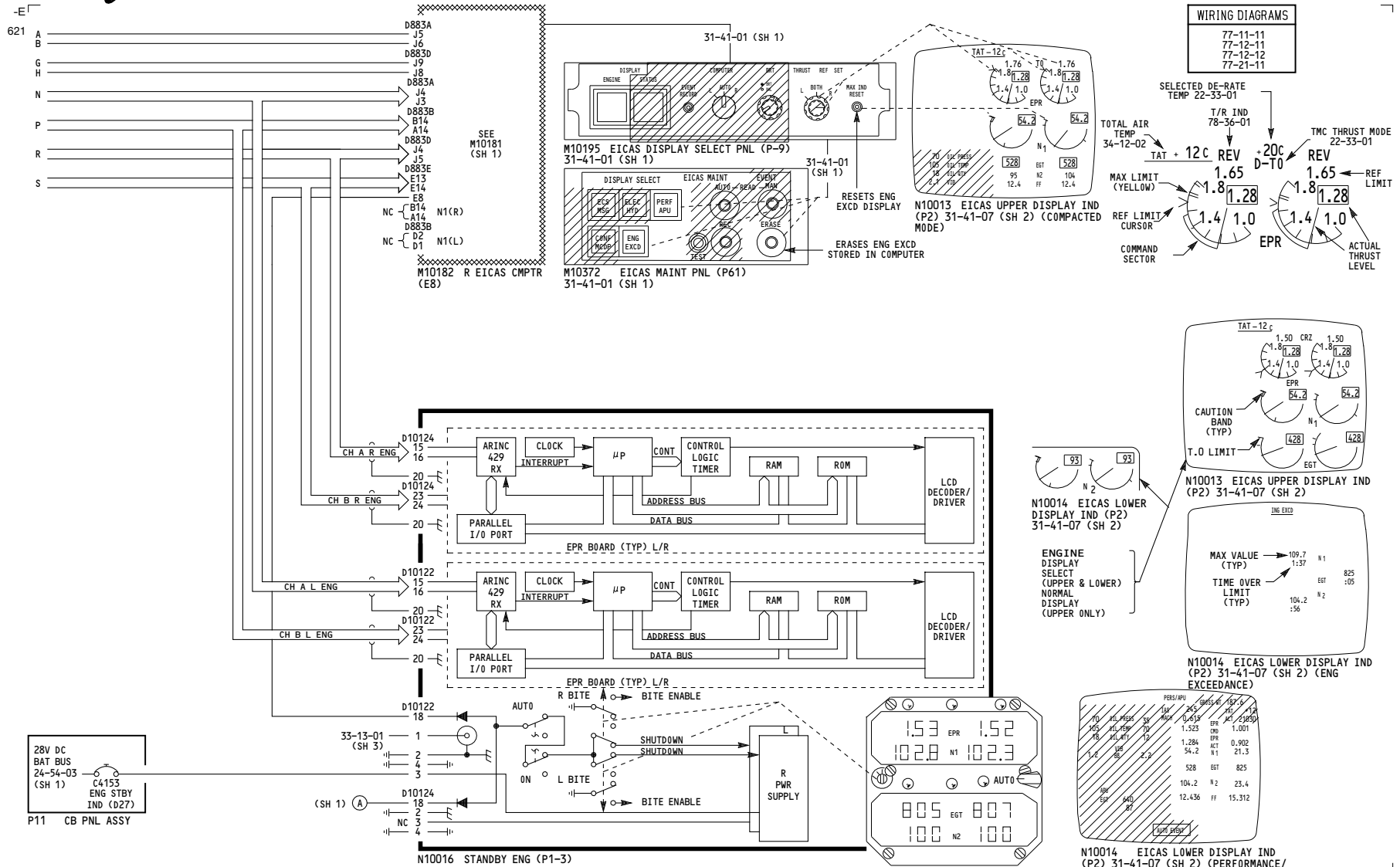

155-157, 166-199, 277-299

ENGINE INDICATING

D280T232

77-00-01

630

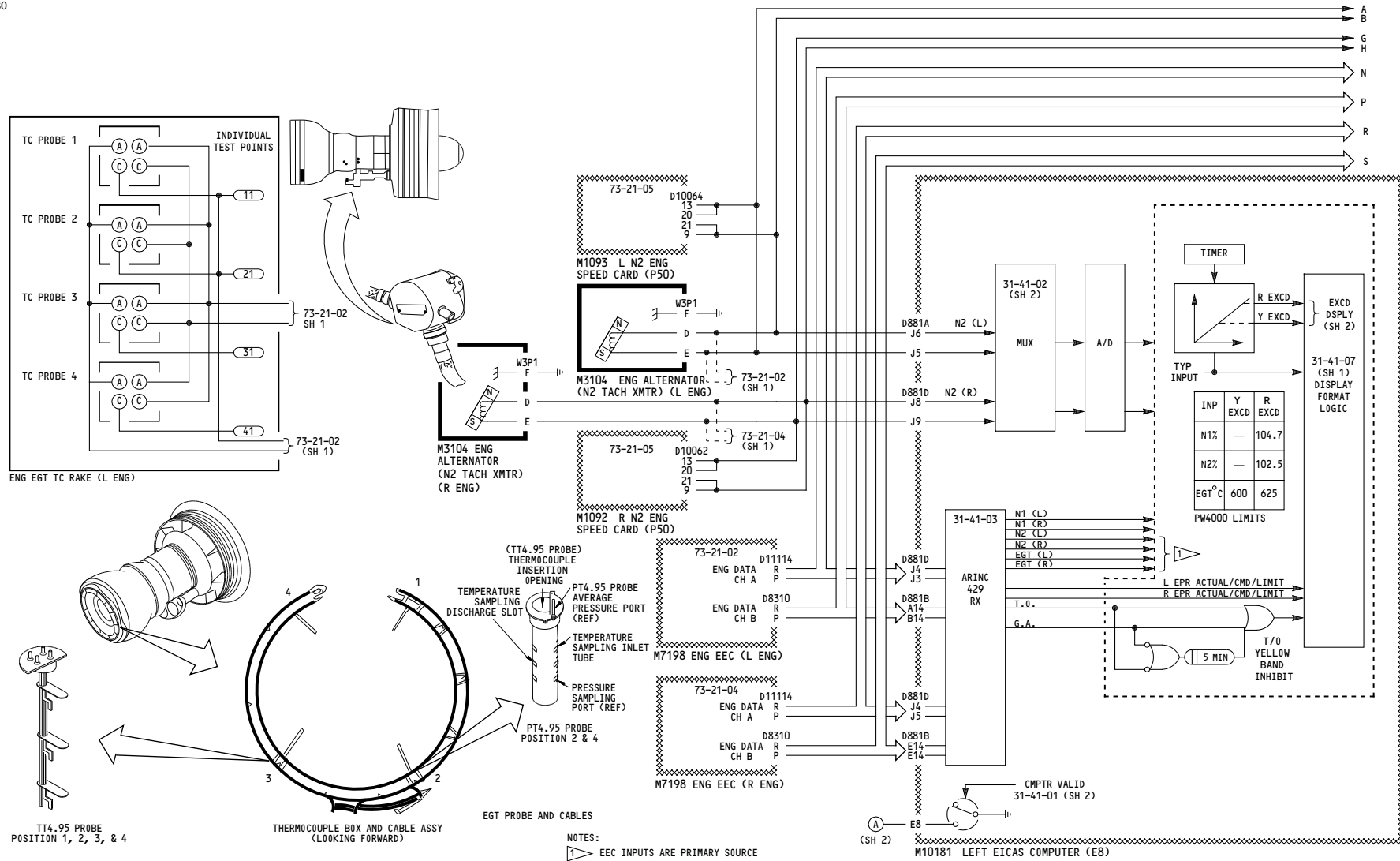

275-276

ENGINE INDICATING

Incorporates
76-0026

D280T232

77-00-01

Page 104.1
Sheet 1
Jan 21/2005

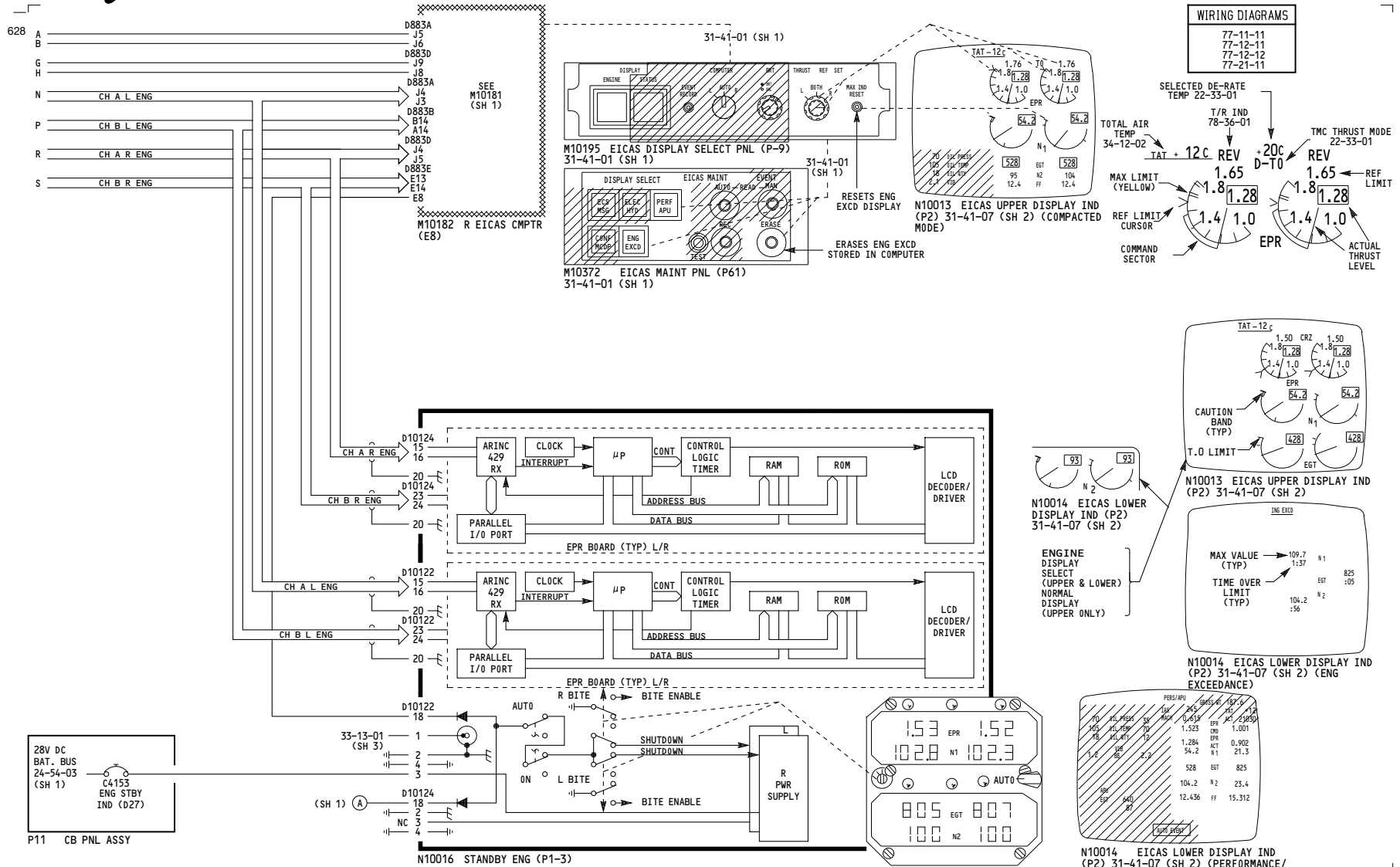

P11 CB PNL ASSY

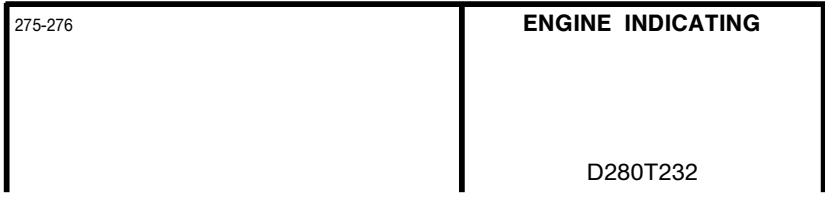

Incorporates
73-0036

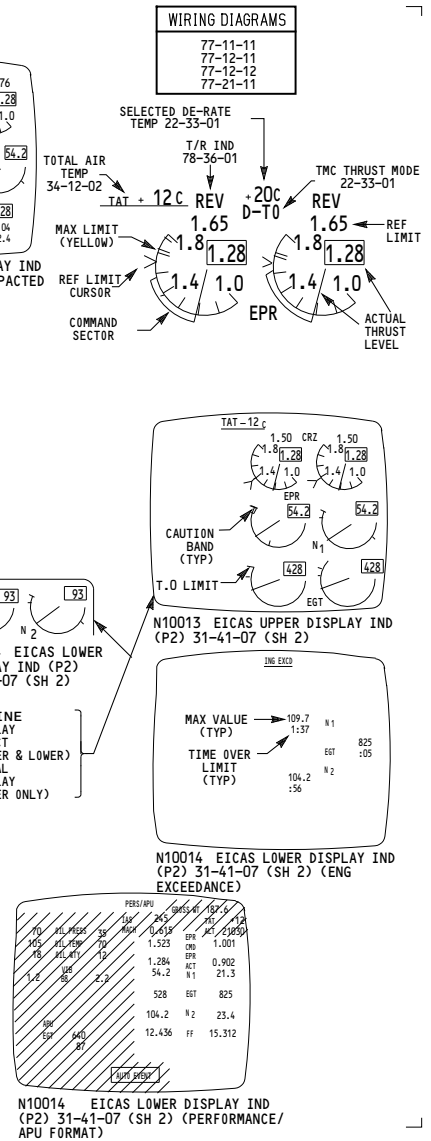

77-00-01

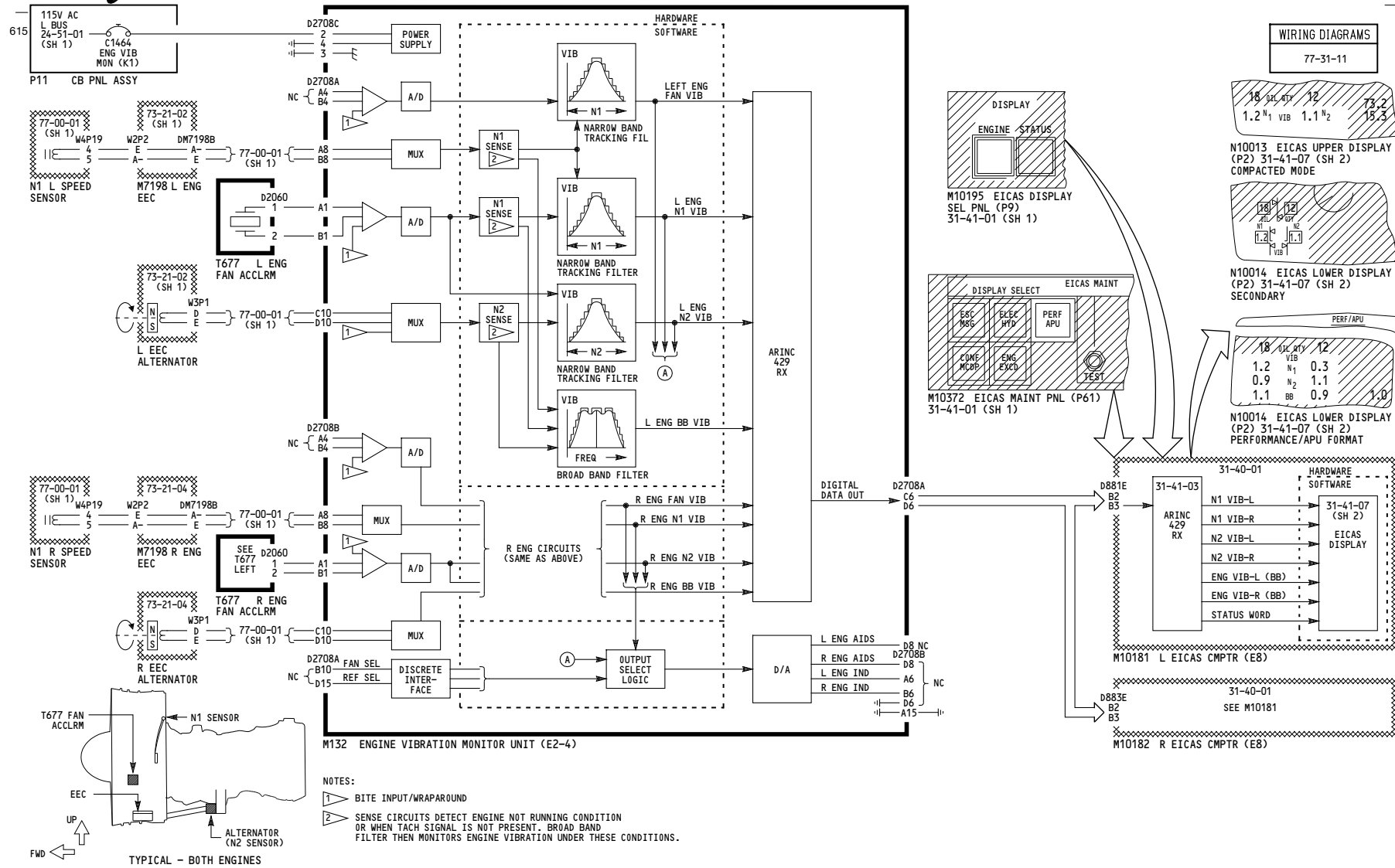

77-00-02

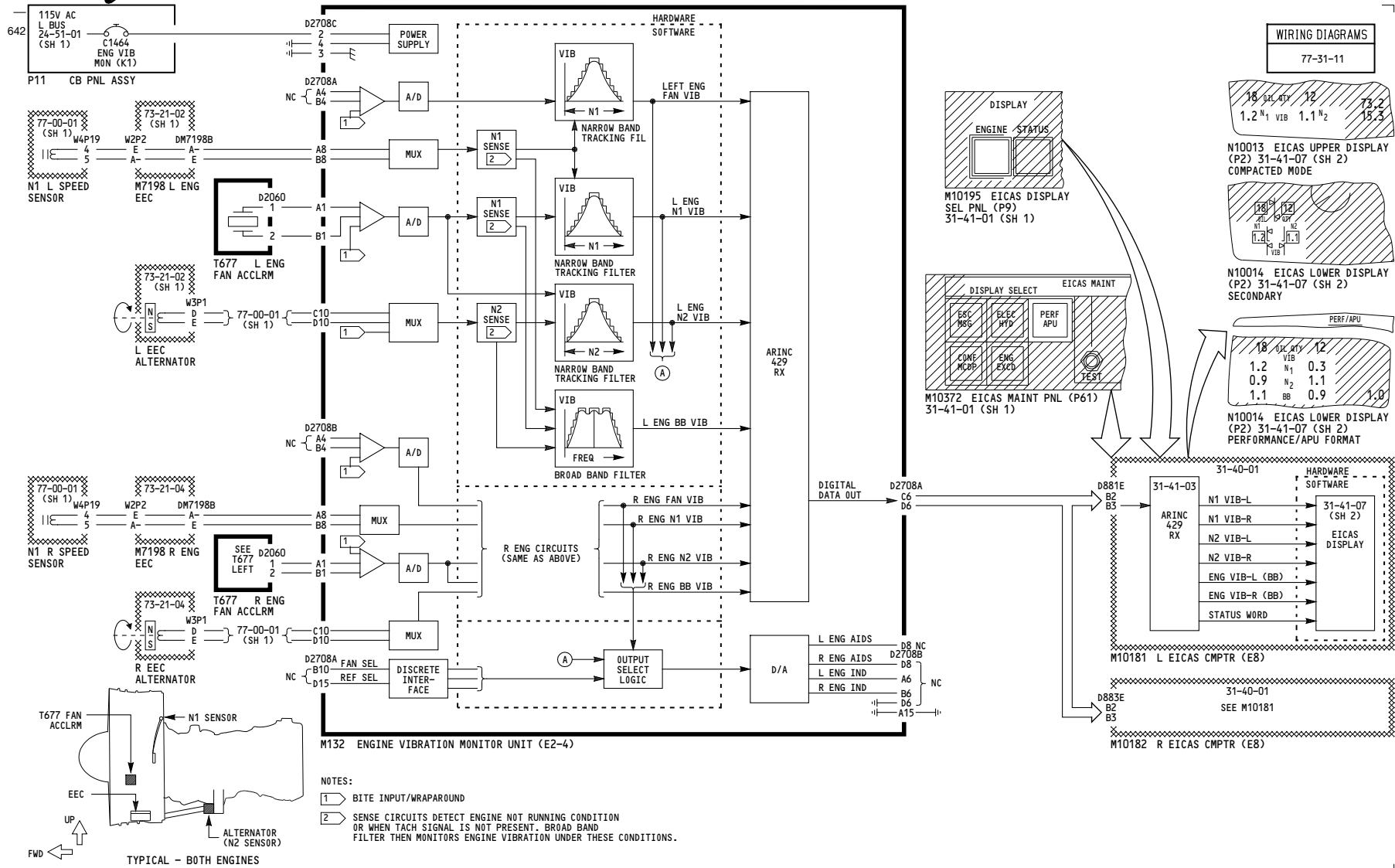

Incorporates
77-0017

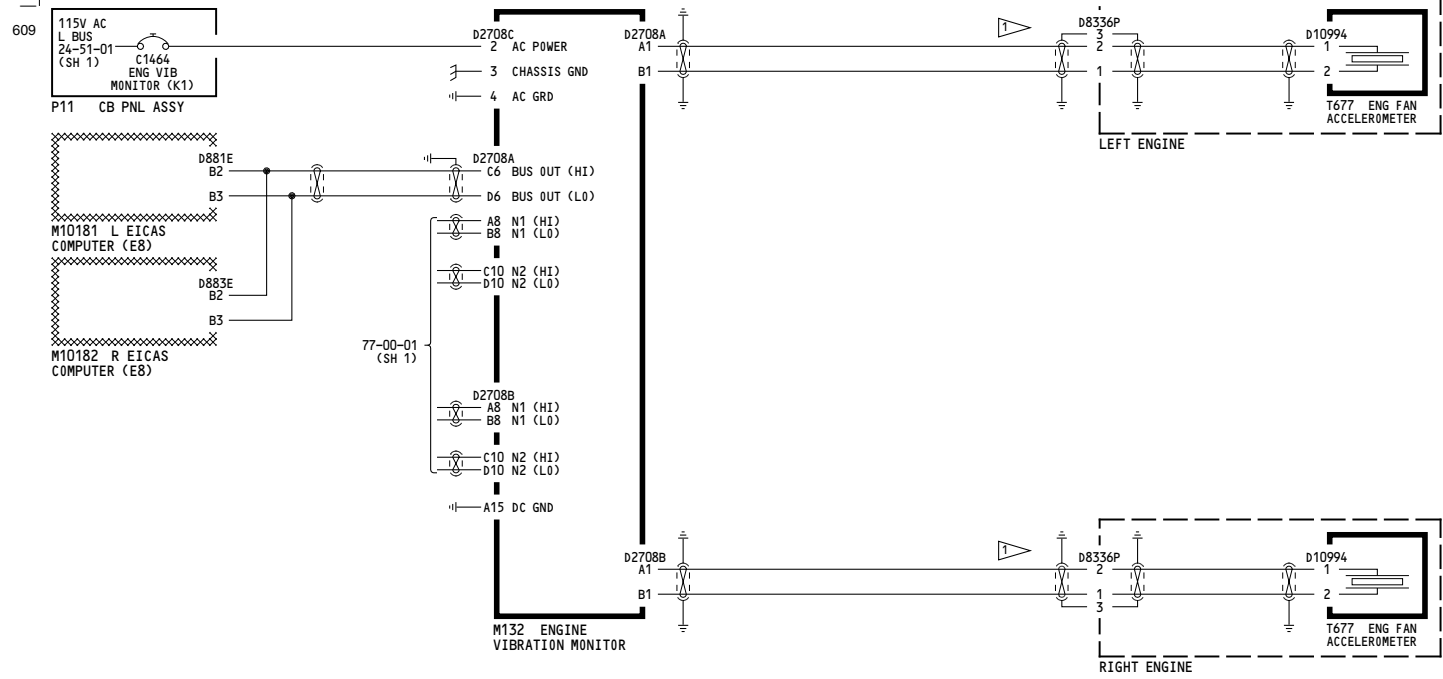

NOTES:
 1 USE #20 AWG, TWISTED PAIR, DOUBLE SHIELDED, LOW NOISE WIRE.

050-099, 155-157, 164-199, 277-299	<p align="center">AIRBORNE VIBRATION MONITORING</p> <p align="center">D280T232</p>
------------------------------------	---

77-31-01

Page 101

Jan 21/2005

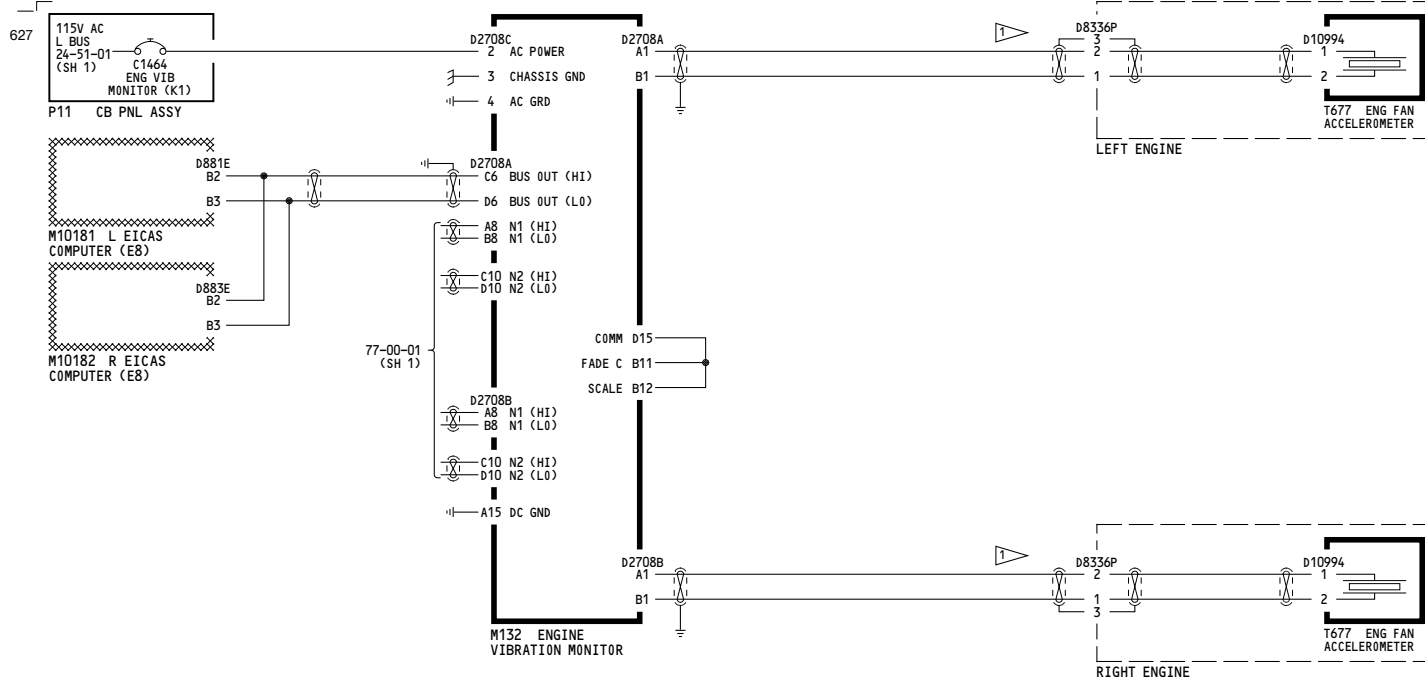

NOTES:
 USE #20 AWG, TWISTED PAIR,
 SINGLE SHIELDED, LOW NOISE WIRE.

150-154	<p>AIRBORNE VIBRATION MONITORING</p> <p>D280T232</p>
---------	---

Incorporates
 77-0013

77-31-01

Page 102.1

Jan 21/2005

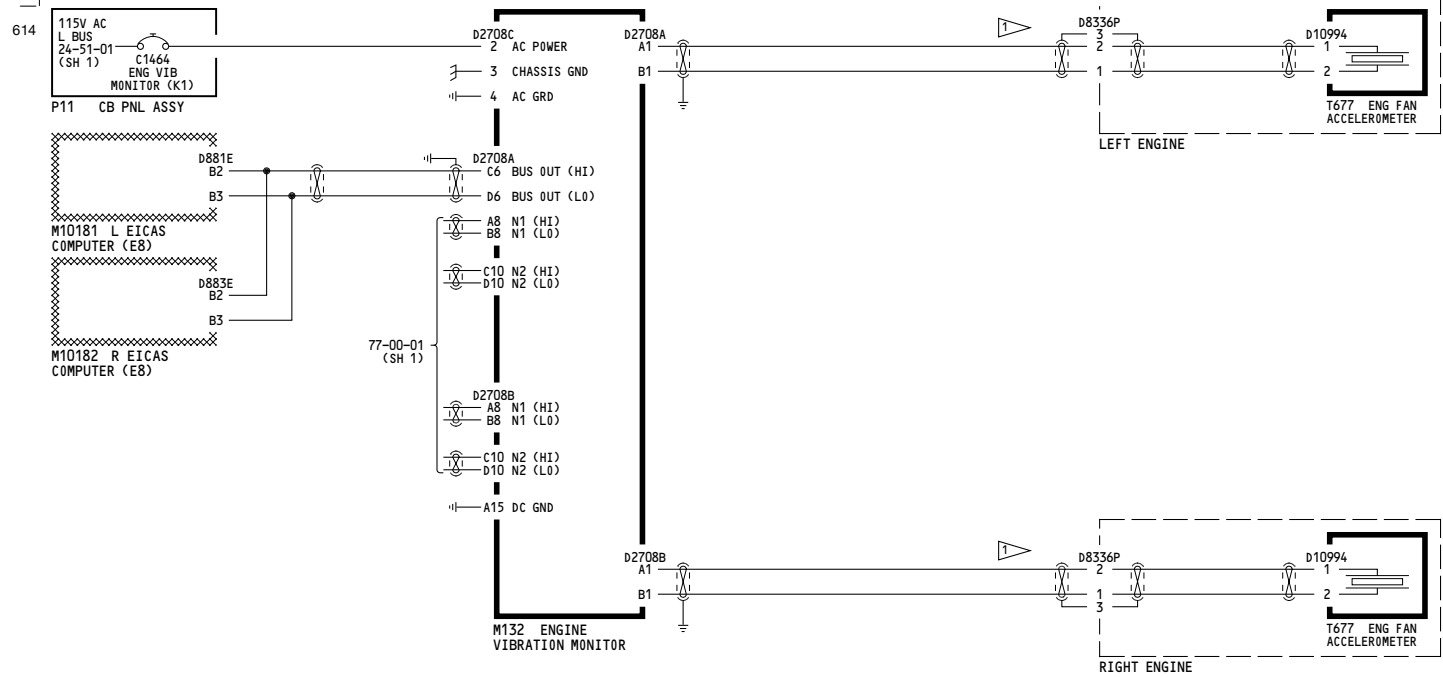

NOTES:
 USE #20 AWG, TWISTED PAIR, SINGLE SHIELDED, LOW NOISE WIRE.

275-276	<p align="center">AIRBORNE VIBRATION MONITORING</p> <p align="center">D280T232</p>
---------	---

77-31-01

Page 103

Jan 21/2005

THIS PAGE INTENTIONALLY LEFT BLANK

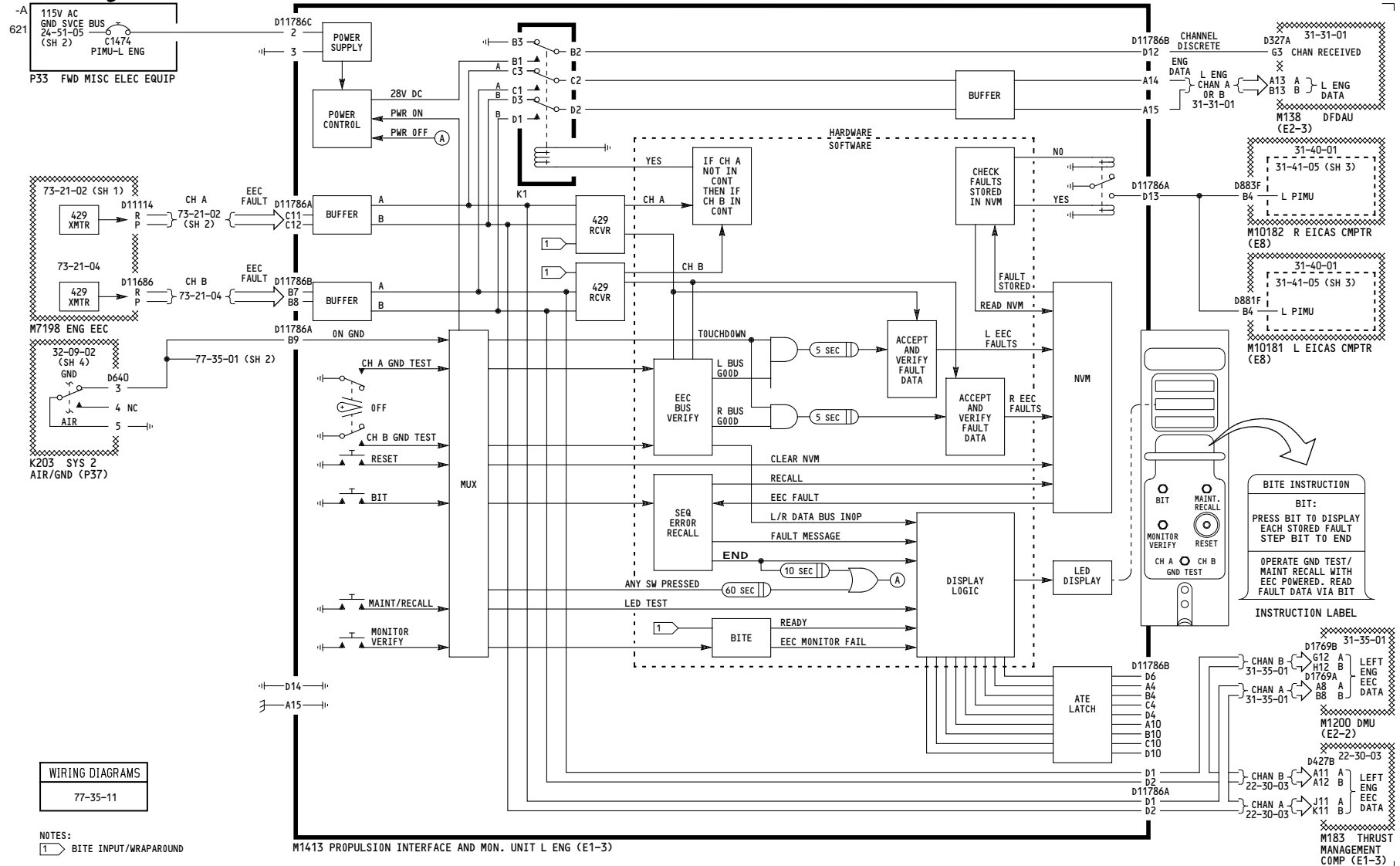

050-099, 155-199, 277-299

ELECTRONIC ENGINE CONTROL MONITOR

D280T232

77-35-01

Page 101
Sheet 1
Mar 14/2007

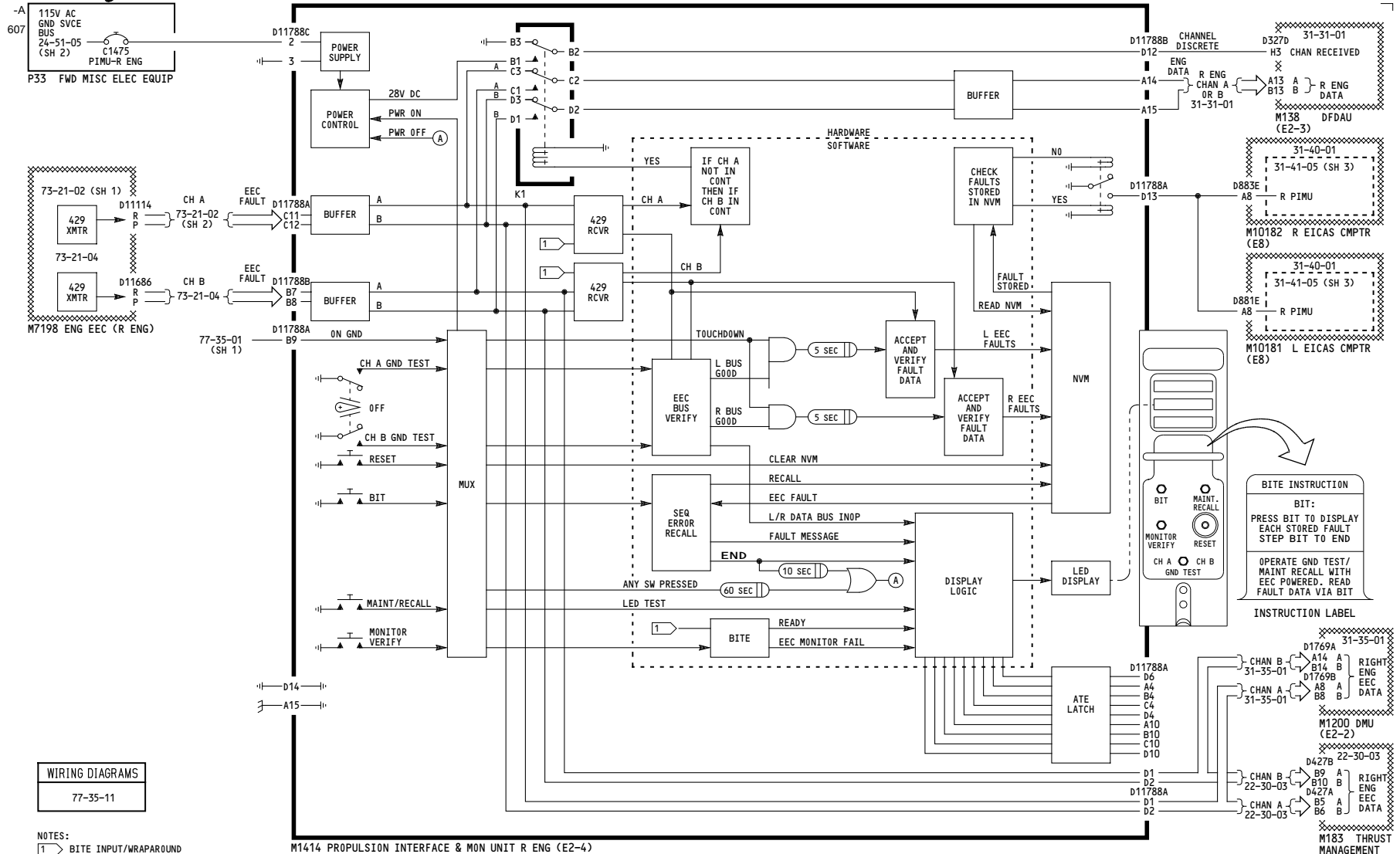

050-099, 155-199, 277-299

ELECTRONIC ENGINE CONTROL MONITOR

D280T232

77-35-01

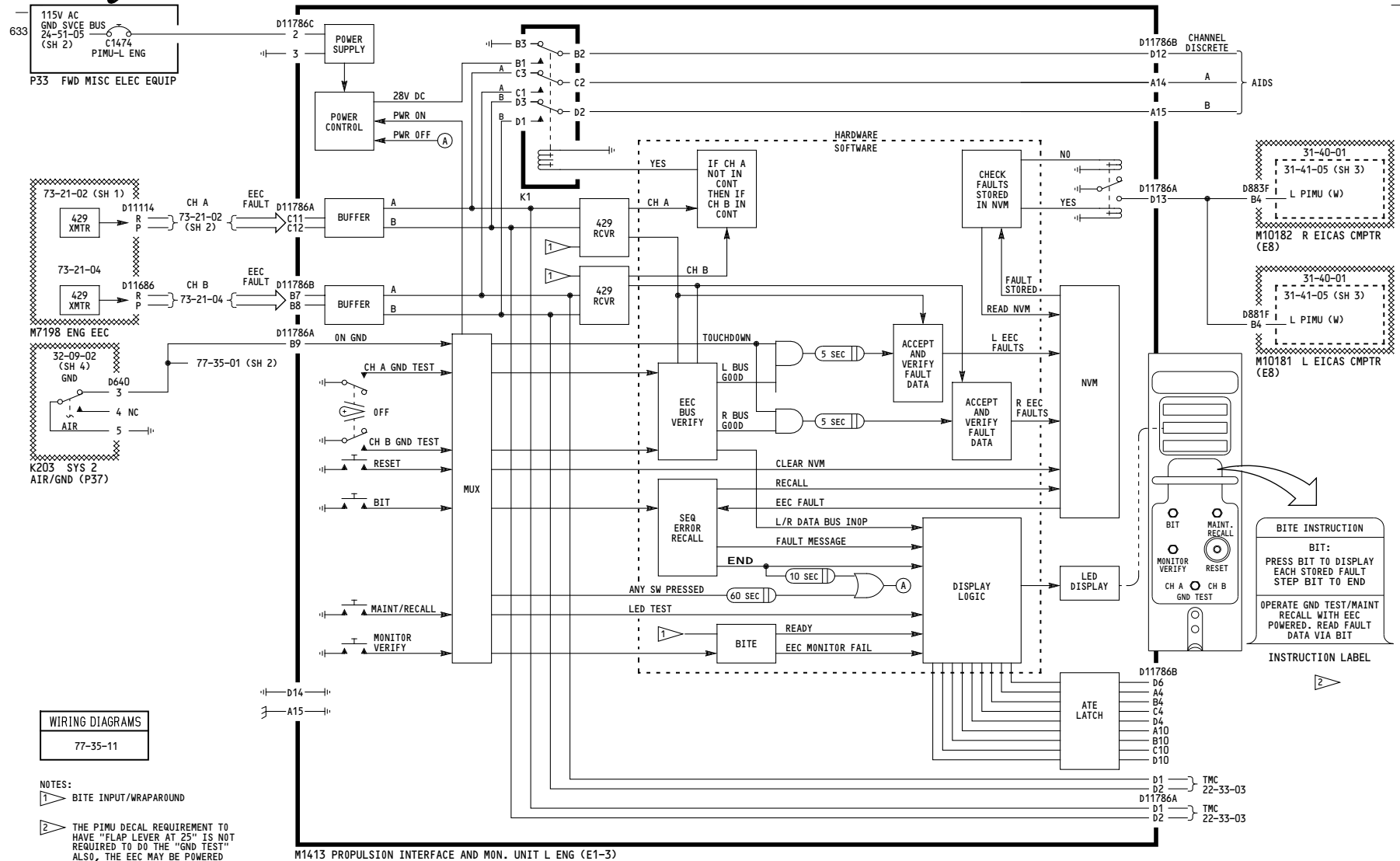

150-154, 275-276

ELECTRONIC ENGINE CONTROL MONITOR

D280T232

77-35-01

Page 102
 Sheet 1
 Jan 21/2005

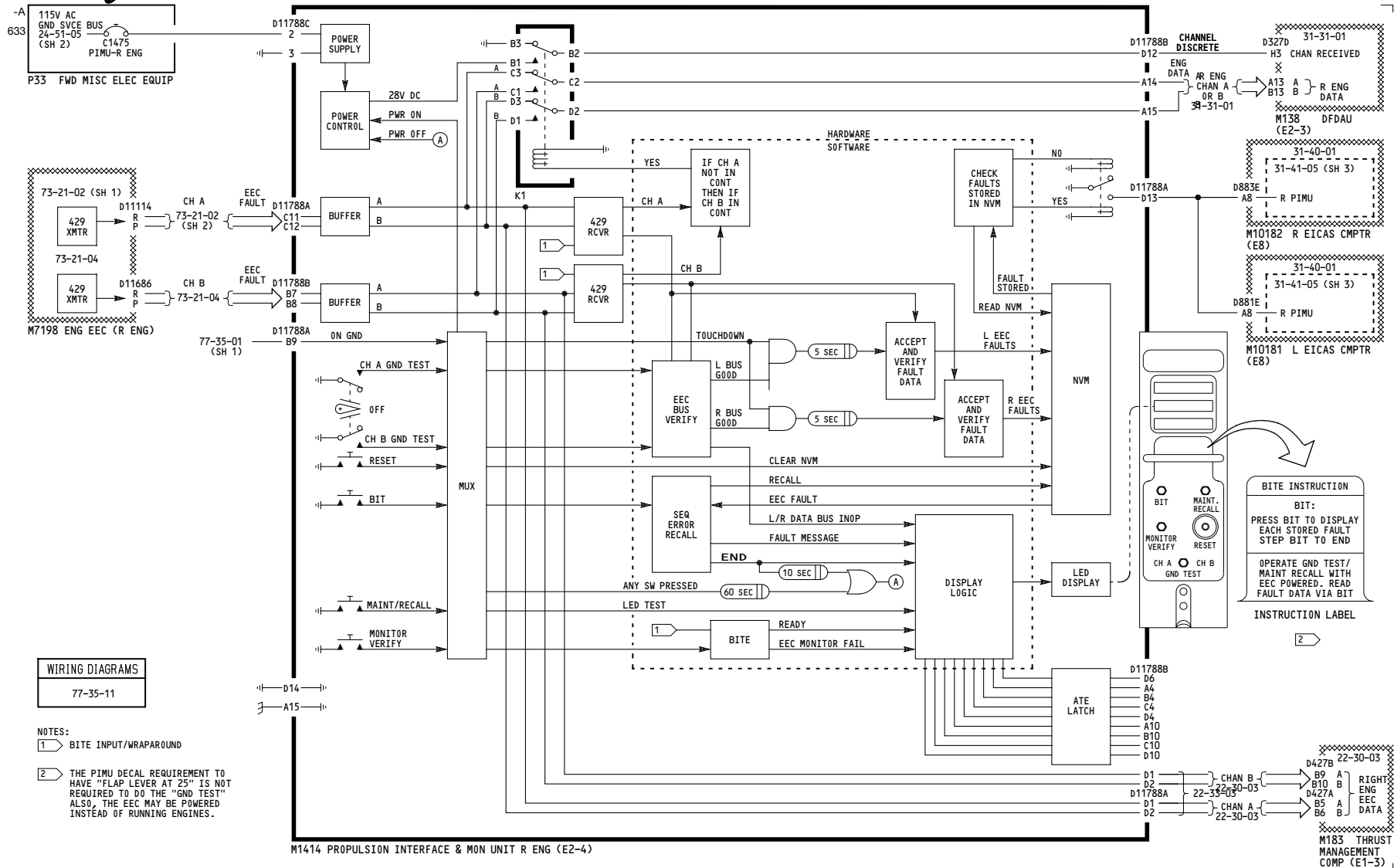

150-154, 275-276

ELECTRONIC ENGINE CONTROL MONITOR

D280T232

77-35-01

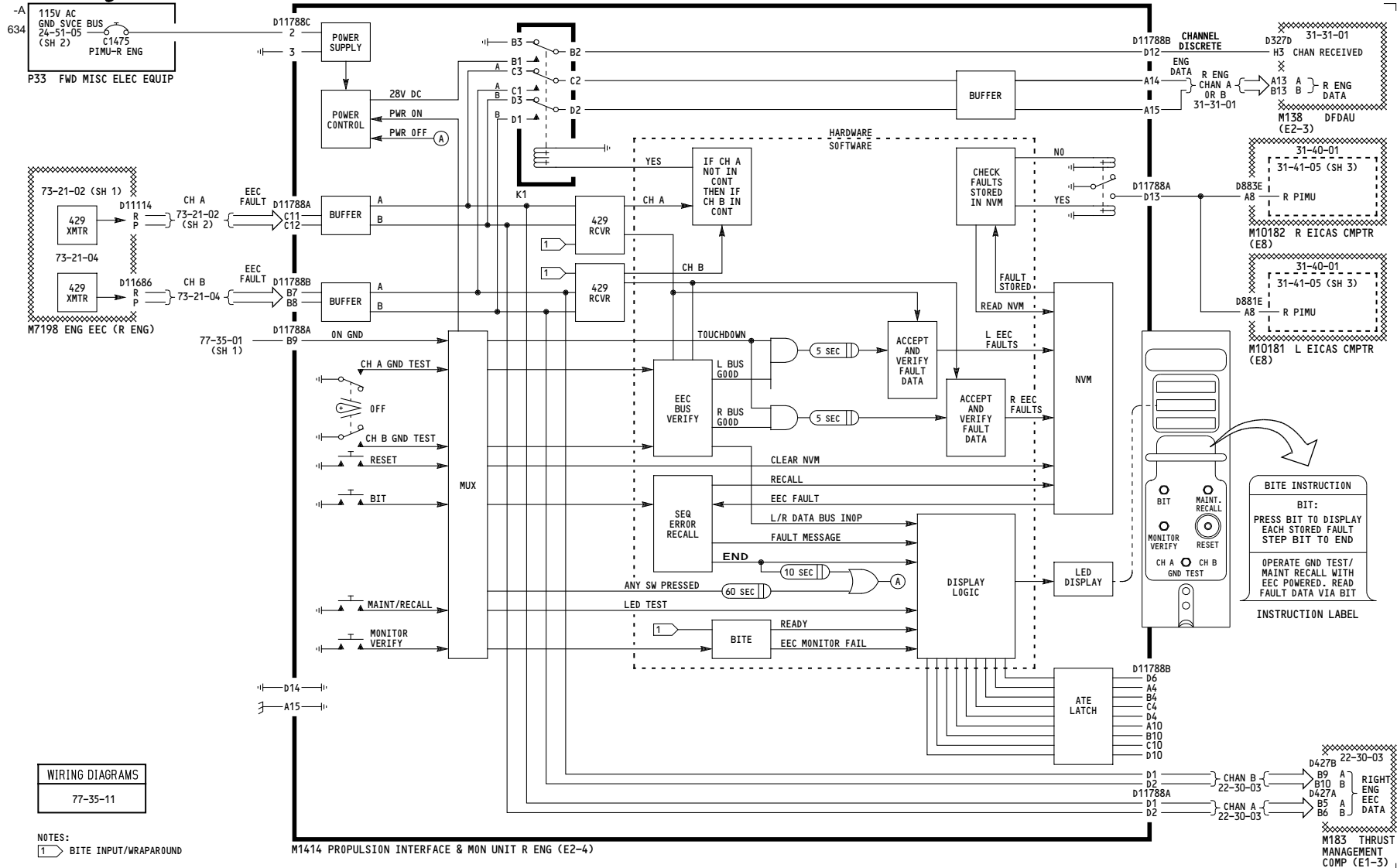

WIRING DIAGRAMS
77-35-11

NOTES:
1 BITE INPUT/WRAPAROUND

M1414 PROPULSION INTERFACE & MON UNIT R ENG (E2-4)

150-154, 275-276

ELECTRONIC ENGINE CONTROL MONITOR

Incorporates
77-0007

D280T232

77-35-01

Page 102.1
Sheet 2
Mar 14/2007