

CHAPTER

23

COMMUNICATIONS



767-200/300

WIRING DIAGRAM MANUAL

CHAPTER 23
COMMUNICATIONS

CH-SC-SU	Schem	Page	Sheet	Date	CH-SC-SU	Schem	Page	Sheet	Date
23-EFFECTIVE PAGES					23-12-31 (cont.)				
		1 thru 5		Aug 05/2009			2A		Mar 14/2007
		6		BLANK			3		Mar 14/2007
23-CONTENTS							4A		Mar 14/2007
		1		Mar 14/2007			5A		Mar 14/2007
		2		Mar 14/2007	23-19-11				
		3		Jun 28/2006			1A	1	Jan 21/2005
		4		Jun 28/2006				2	Jan 21/2005
		5		Jun 28/2006				3	Jan 21/2005
		6		Jun 28/2006				4	Jan 21/2005
		7		Jun 28/2006				5	Jan 21/2005
		8		Jun 28/2006				6	Jan 21/2005
		9		Jun 28/2006				7	Jan 21/2005
		10		Jun 28/2006				8	Jan 21/2005
R		11		Aug 05/2009			2A	1	Jan 21/2005
		12		Jun 28/2006				2	Jan 21/2005
		13		Jun 28/2006				3	Jan 21/2005
		14		BLANK				4	Jan 21/2005
23-ALPHABETICAL INDEX								5	Jan 21/2005
		1		Jan 21/2005				6	Jan 21/2005
		2		Jan 21/2005				7	Jan 21/2005
		3		Jan 21/2005				8	Jan 21/2005
		4		BLANK	23-21-11				
23-11-11		1		Jan 21/2005			1		Jan 21/2005
		2		Jan 21/2005			2A		Jan 21/2005
		3		Jan 21/2005			3		Jan 21/2005
		4		Jan 21/2005			4A		Jan 21/2005
23-11-21		1		Jan 21/2005			5A		Jan 21/2005
		2		Jan 21/2005			6		Jan 21/2005
		3		Jan 21/2005			7		Jan 21/2005
		4		Jan 21/2005			8A		Jan 21/2005
23-12-11		1		Jan 21/2005			9		Jan 21/2005
		2A		Jan 21/2005	23-21-12				
		3		Jan 21/2005			1		Jan 21/2005
		4A		Jan 21/2005	23-22-11				
		5A		Jan 21/2005			1		Jan 21/2005
		6A		Jan 21/2005			2A		Jan 21/2005
		7A		Jan 21/2005			3A		Jan 21/2005
		8A		Jan 21/2005			4A		Jan 21/2005
23-12-21		1		Jan 21/2005			5A		Jan 21/2005
		2.1A		Jan 21/2005			6A		Jan 21/2005
		3.1		Jan 21/2005	23-22-12				
		4A		Jan 21/2005			1A		Jan 21/2005
		5A		Jan 21/2005			2A	1	Jan 21/2005
		6.1A		Jan 21/2005				2	Jan 21/2005
		7A		Jan 21/2005			3		Jan 21/2005
23-12-31		1		Mar 14/2007			4A	1	Jan 21/2005
							5A	1	Jan 21/2005
							6A	1	Jan 21/2005
								2	Jan 21/2005

A = Added, R = Revised, D = Deleted, O = Overflow

23-EFFECTIVE PAGES

Page 1
Aug 05/2009

D280T132



767-200/300

WIRING DIAGRAM MANUAL

CHAPTER 23
COMMUNICATIONS

CH-SC-SU	Schem	Page	Sheet	Date	CH-SC-SU	Schem	Page	Sheet	Date
23-22-12 (cont.)		7A		Jan 21/2005	23-25-16	1A			Jan 21/2005
		8A		Jan 21/2005		2A			Jan 21/2005
		9A		Jan 21/2005		3A			Jan 21/2005
23-22-13						4A			Jan 21/2005
		1A		Jun 28/2006		5			Jan 21/2005
		2A		Jan 21/2005	23-25-17				
		3A		Jan 21/2005		1A	1		Jan 21/2005
		4		Jan 21/2005			2		Jan 21/2005
		5		Jan 21/2005		2A	1		Jan 21/2005
23-22-15							2		Jan 21/2005
		1		Jan 21/2005		3A	1		Jan 21/2005
		2.1		Jan 21/2005			2		Jan 21/2005
		3		May 20/2005		4	1		Jan 21/2005
23-24-11							2		Jan 21/2005
		1		Jan 21/2005	23-31-11				
		2		Jan 21/2005		1A			Jan 21/2005
23-25-11						2.1A			Jan 21/2005
		1A		Jan 21/2005		3.1A			Jan 21/2005
		2A		Jan 21/2005		4.1A			Jan 21/2005
		3A		Jan 21/2005		5A			Jan 21/2005
		4A		Jan 21/2005		6.1			Jan 21/2005
		5		Jan 21/2005		7.1A			Jan 21/2005
23-25-12						8			Jan 21/2005
		1A		Jan 21/2005		9			Jan 21/2005
		2A		Jan 21/2005	23-31-12				
		3A		Jan 21/2005		1A			Jan 21/2005
		4		Jan 21/2005		2			Jan 21/2005
23-25-13						3			Jan 21/2005
		1A	1	Jan 21/2005		4			Jan 21/2005
			2	Jan 21/2005	23-31-13				
		2A	1	Jan 21/2005		1A	1		Jan 21/2005
			2	Jan 21/2005			2		Jan 21/2005
		3A	1	Jan 21/2005		2A			Jan 21/2005
			2	Jan 21/2005		3A	1		Jan 21/2005
		4A	1	Jan 21/2005			2		Jan 21/2005
			2	Jan 21/2005		4A			Jan 21/2005
		5		Jan 21/2005		5A	1		Jan 21/2005
		6		Jan 21/2005			2		Jan 21/2005
23-25-14						6A	1		Jan 21/2005
		1A		Jan 21/2005			2		Jan 21/2005
		2A		Jan 21/2005		7A	1		Jan 21/2005
		3A		Jan 21/2005			2		Jan 21/2005
		4A		Jan 21/2005		8A	1		Jan 21/2005
		5A		Jan 21/2005			2		Jan 21/2005
		6		Jan 21/2005		9			Jan 21/2005
23-25-15					23-31-14				
		1A		Jan 21/2005		1A	1		Jan 21/2005
		2A		Jan 21/2005			2		Jan 21/2005
		3A		Jan 21/2005		2A	1		Jan 21/2005
		4A		Jan 21/2005			2		Jan 21/2005
		5		Jan 21/2005		3A	1		Jan 21/2005

A = Added, R = Revised, D = Deleted, O = Overflow

23-EFFECTIVE PAGES

Page 2
Aug 05/2009

D280T132



767-200/300

WIRING DIAGRAM MANUAL

CHAPTER 23
COMMUNICATIONS

CH-SC-SU	Schem	Page	Sheet	Date	CH-SC-SU	Schem	Page	Sheet	Date
23-31-14 (cont.)	3A				23-32-13				
			2	Jan 21/2005		1A	1	1	Jan 21/2005
	4A		1	Jan 21/2005				2	Jan 21/2005
			2	Jan 21/2005		2A	1	1	Jan 21/2005
	5			Jan 21/2005				2	Jan 21/2005
	6			Jan 21/2005				3	Jan 21/2005
23-31-15						3	1	1	Jan 21/2005
	1		1	Jan 21/2005				2	Jan 21/2005
			2	Jan 21/2005		4A	1	1	Jan 21/2005
	2		1	Jan 21/2005				2	Jan 21/2005
			2	Jan 21/2005		5A	1	1	Jan 21/2005
	3			Jan 21/2005				2	Jan 21/2005
	4			Jan 21/2005				3	Jan 21/2005
23-31-16								4	Jan 21/2005
	1		1	Jan 21/2005		6			Jan 21/2005
			2	Jan 21/2005		7			Jan 21/2005
	2		1	Jan 21/2005	23-32-21				
			2	Jan 21/2005		1A			Jan 21/2005
	3			Jan 21/2005		2A	1	1	Jan 21/2005
	4			Jan 21/2005				2	Jan 21/2005
	5		1	Jan 21/2005		3			Jan 21/2005
			2	Jan 21/2005		4A	1	1	Jan 21/2005
23-31-17								2	Jan 21/2005
	1		1	Jan 21/2005		5A	1	1	Jan 21/2005
			2	Jan 21/2005				2	Jan 21/2005
	2		1	Jan 21/2005		6A	1	1	Jan 21/2005
			2	Jan 21/2005				2	Jan 21/2005
	3			Jan 21/2005		7			Jan 21/2005
	4			Jan 21/2005		8			Jan 21/2005
23-32-11						9			Jan 21/2005
	1A			Jan 21/2005	23-32-31				
	2A			Jan 21/2005		1			Jan 21/2005
	3A			Jan 21/2005		2			Jan 21/2005
	4A			Jan 21/2005	23-32-32				
	5A			Jan 21/2005		1			Jan 21/2005
	6A			Jan 21/2005		2			Jan 21/2005
	7			Jan 21/2005	23-32-33				
	8			Jan 21/2005		1			Jan 21/2005
	9			Jan 21/2005	23-32-34				
23-32-12						1			Jan 21/2005
	1A		1	Jan 21/2005		2			Jan 21/2005
			2	Jan 21/2005	23-32-41				
	2A		1	Jan 21/2005		1			Jan 21/2005
			2	Jan 21/2005	23-32-42				
	3A		1	Jan 21/2005		1			Jan 21/2005
			2	Jan 21/2005	23-32-43				
	4A		1	Jan 21/2005		1			Jan 21/2005
			2	Jan 21/2005		2			Jan 21/2005
	5A		1	Jan 21/2005	23-32-44				
			2	Jan 21/2005		1			Jan 21/2005
	6			Jan 21/2005	23-32-51				
	7			Jan 21/2005		1			Jan 21/2005

A = Added, R = Revised, D = Deleted, O = Overflow

23-EFFECTIVE PAGES

Page 3
Aug 05/2009

D280T132



767-200/300

WIRING DIAGRAM MANUAL

CHAPTER 23
COMMUNICATIONS

CH-SC-SU	Schem	Page	Sheet	Date	CH-SC-SU	Schem	Page	Sheet	Date
23-32-51 (cont.)		2		Jan 21/2005	23-34-16		1		Jan 21/2005
23-32-52		1		Jan 21/2005			2		Jan 21/2005
23-32-53		1		Jan 21/2005			3		Jan 21/2005
23-32-54		1		Jan 21/2005	R 23-34-17		4		Jan 21/2005
23-32-61		1		Jan 21/2005			5		Aug 05/2009
23-32-62		1		Jan 21/2005			1		Jan 21/2005
23-34-11		1		Jan 21/2005	R 23-34-18		2		Jan 21/2005
		2		Jan 21/2005			3		Jan 21/2005
		3		Jan 21/2005			4		Aug 05/2009
		4		Jan 21/2005	23-34-19		1		Jan 21/2005
23-34-12		1		Jan 21/2005			2		Jan 21/2005
		2		Jan 21/2005			3		Jan 21/2005
23-34-13		1		Jan 21/2005			4		Jan 21/2005
		2		Jan 21/2005	23-41-11		1		Jan 21/2005
		3		Jan 21/2005			2		Jan 21/2005
		4		Jan 21/2005			3		Jan 21/2005
		5		Jan 21/2005			4.1		Jan 21/2005
		6		Jan 21/2005	23-42-11		1A	1	Jan 21/2005
		7	1	Jan 21/2005				2	Jan 21/2005
			2	Jan 21/2005				3	Jan 21/2005
		7.1	1	Jan 21/2005				2	Jan 21/2005
			2	Jan 21/2005				1	Jan 21/2005
		8	1	Jan 21/2005				2	Jan 21/2005
			2	Jan 21/2005				4	1 Jan 21/2005
		9	1	Jan 21/2005				5	2 Jan 21/2005
			2	Jan 21/2005				6	1 Jan 21/2005
23-34-14		1A		Jan 21/2005				7	3 Jan 21/2005
		2A		Jan 21/2005				7.1	Jan 21/2005
		3		Jan 21/2005				8	Jan 21/2005
		4		Jan 21/2005				9	1 Jan 21/2005
		5		Jan 21/2005				2	Jan 21/2005
23-34-15									
R		1	1	Aug 05/2009					
			2	Jan 21/2005					
		2		Jan 21/2005	23-42-12		1		Jan 21/2005
R		3	1	Aug 05/2009			2		Jan 21/2005
			2	Jan 21/2005			3		Jan 21/2005
			3	Jan 21/2005					
		4		Jan 21/2005	23-43-11		1		Jan 21/2005
		5		Jan 21/2005			2		Jan 21/2005
R		6		Aug 05/2009			3.1		Jan 21/2005

A = Added, R = Revised, D = Deleted, O = Overflow

23-EFFECTIVE PAGES

Page 4
Aug 05/2009

D280T132



767-200/300

WIRING DIAGRAM MANUAL

CHAPTER 23 COMMUNICATIONS

CH-SC-SU	Schem	Page	Sheet	Date	CH-SC-SU	Schem	Page	Sheet	Date
23-51-11		1		Jan 21/2005					
		2.1A		Jan 21/2005					
		3.1		Jan 21/2005					
		4		Jan 21/2005					
		5.1		Jan 21/2005					
		6		Jan 21/2005					
23-51-12		1		Jan 21/2005					
		2		Jan 21/2005					
		3		Jan 21/2005					
23-51-13		1		Jan 21/2005					
		2		Jan 21/2005					
23-51-14		1		Jan 21/2005					
		2A		Jan 21/2005					
		3		Jan 21/2005					
		4A		Jan 21/2005					
23-51-21		1		Jan 21/2005					
		2.1A		Jan 21/2005					
		3.1		Jan 21/2005					
		4		Jan 21/2005					
23-51-41		1		Jan 21/2005					
		2.1		Jan 21/2005					
		3		Jan 21/2005					
23-71-11		1		Jan 21/2005					

A = Added, R = Revised, D = Deleted, O = Overflow

23-EFFECTIVE PAGES

Page 5
Aug 05/2009

D280T132



767-200/300

WIRING DIAGRAM MANUAL

**CHAPTER 23
COMMUNICATIONS**

Title	CH-SC-SU	Schem	Page	Sheet	Date	Effectivity
<u>HF COMMUNICATION SYSTEM</u>						
HF COMMUNICATION- LEFT	23-11-11		1		Jan 21/2005	050-099 150-154 162-164 275-276
			2		Jan 21/2005	155 165
			3		Jan 21/2005	156 166
			4		Jan 21/2005	157 167-199 277-299
HF COMMUNICATION- RIGHT	23-11-21		1		Jan 21/2005	050-099 150-154 162-164 275-276
			2		Jan 21/2005	155 165
			3		Jan 21/2005	156 166
			4		Jan 21/2005	157 167-199 277-299
<u>VHF COMMUNICATION SYSTEM</u>						
VHF COMMUNICATION- LEFT	23-12-11		1		Jan 21/2005	050-099
			2A		Jan 21/2005	150 152-156
			3		Jan 21/2005	151
			4A		Jan 21/2005	157
			5A		Jan 21/2005	162-166
			6A		Jan 21/2005	167
			7A		Jan 21/2005	275-276
			8A		Jan 21/2005	277-280
VHF COMMUNICATION- RIGHT	23-12-21		1		Jan 21/2005	050-099
			2.1A		Jan 21/2005	150 152
			3.1		Jan 21/2005	151
			4A		Jan 21/2005	153-156 162-166
			5A		Jan 21/2005	157 167
			6.1A		Jan 21/2005	275-276
VHF COMMUNICATION- CENTER	23-12-31		1		Mar 14/2007	050-099
			2A		Mar 14/2007	150 152-156 162-166 275-276
			3		Mar 14/2007	151
			4A		Mar 14/2007	157 277-280

23-CONTENTS



767-200/300

WIRING DIAGRAM MANUAL

CHAPTER 23 COMMUNICATIONS

Title	CH-SC-SU	Schem	Page	Sheet	Date	Effectivity
VHF COMMUNICATION-CENTER (cont.)	23-12-31		5A		Mar 14/2007	167
<u>AIR-TO-GROUND PUBLIC TELEPHONE SYSTEM</u>						
AIR-TO-GROUND PUBLIC TELEPHONE	23-19-11		1A	1	Jan 21/2005	150
				2	Jan 21/2005	150
				3	Jan 21/2005	150
				4	Jan 21/2005	150
				5	Jan 21/2005	150
				6	Jan 21/2005	150
				7	Jan 21/2005	150
				8	Jan 21/2005	150
			2A	1	Jan 21/2005	152-167
				2	Jan 21/2005	152-167
				3	Jan 21/2005	152-167
				4	Jan 21/2005	152-167
				5	Jan 21/2005	152-167
				6	Jan 21/2005	152-167
				7	Jan 21/2005	152-167
				8	Jan 21/2005	152-167
<u>SELCAL SYSTEM</u>						
SELCAL	23-21-11		1		Jan 21/2005	050-099
				2A	Jan 21/2005	150 153-154
				3	Jan 21/2005	151
				4A	Jan 21/2005	152
				5A	Jan 21/2005	155
				6	Jan 21/2005	156 166
				7	Jan 21/2005	157 167-199 277-299
				8A	Jan 21/2005	162-165
				9	Jan 21/2005	275-276
SELCAL CODING	23-21-12		1		Jan 21/2005	ALL
<u>AIRCRAFT COMMUNICATIONS ADDRESSING AND REPORTING SYSTEM (ACARS)</u>						
ACARS- POWER CONTROL & OOOI	23-22-11		1		Jan 21/2005	050-099 151

23-CONTENTS

Page 2

Mar 14/2007

D280T132



767-200/300

WIRING DIAGRAM MANUAL

CHAPTER 23
COMMUNICATIONS

Title	CH-SC-SU	Schem	Page	Sheet	Date	Effectivity		
ACARS- POWER CONTROL & OOOI (cont.)	23-22-11		2A		Jan 21/2005	150 152-166		
			3A		Jan 21/2005	167		
			4A		Jan 21/2005	275-276		
			5A		Jan 21/2005	277-278		
			6A		Jan 21/2005	280		
			1A		Jan 21/2005	050-051		
ACARS, DFDAU, FLIGHT MANAGEMENT COMPUTER INTERFACE	23-22-12		2A	1	Jan 21/2005	150 152		
				2	Jan 21/2005	150 152		
			3		Jan 21/2005	151		
			4A	1	Jan 21/2005	153-155 162-165		
				2	Jan 21/2005	153-155 162-165		
			5A	1	Jan 21/2005	156-157 166		
				2	Jan 21/2005	156-157 166		
			6A	1	Jan 21/2005	167		
				2	Jan 21/2005	167		
			7A		Jan 21/2005	275-276		
			8A		Jan 21/2005	277-278		
			9A		Jan 21/2005	280		
		ACARS CODING	23-22-13		1A		Jun 28/2006	150 152-164 166-167
					2A		Jan 21/2005	151
	3A				Jan 21/2005	165		
	4				Jan 21/2005	275-278		
	5				Jan 21/2005	280-299		
ACARS- DATA LOADER INTERFACE	23-22-15		1		Jan 21/2005	050-099 155-166 275-278		
			2.1		Jan 21/2005	150-154		
			3		May 20/2005	167-199 280-299		
<u>EMERGENCY LOCATOR TRANSMITTER SYSTEM</u>								
EMERGENCY LOCATOR TRANSMITTER	23-24-11		1		Jan 21/2005	050-099		
			2		Jan 21/2005	150-199		

23-CONTENTS

Page 3
Jun 28/2006

D280T132



767-200/300

WIRING DIAGRAM MANUAL

CHAPTER 23
COMMUNICATIONS

Title	CH-SC-SU	Schem	Page	Sheet	Date	Effectivity
SATELLITE COMMUNICATION (SATCOM) SYSTEM						
SATCOM SYSTEM- POWER & LGA SUBSYSTEM	23-25-11		1A		Jan 21/2005	150 153-155
			2A		Jan 21/2005	156-157 166
			3A		Jan 21/2005	162-165
			4A		Jan 21/2005	167
			5		Jan 21/2005	277-299
SATCOM SYSTEM- RADIO FREQUENCY DISTRIBUTION	23-25-12		1A		Jan 21/2005	150 153-155
			2A		Jan 21/2005	156-157 166-167
			3A		Jan 21/2005	162-165
			4		Jan 21/2005	277-299
SATCOM SYSTEM- CONTROL INTERFACES	23-25-13		1A	1	Jan 21/2005	150 153-155
				2	Jan 21/2005	150 153-155
			2A	1	Jan 21/2005	156-157 166
				2	Jan 21/2005	156-157 166
			3A	1	Jan 21/2005	162-165
				2	Jan 21/2005	162-165
			4A	1	Jan 21/2005	167
				2	Jan 21/2005	167
			5		Jan 21/2005	277-278
			6		Jan 21/2005	280-299
SATCOM SYSTEM- AUDIO INTERFACES	23-25-14		1A		Jan 21/2005	150
			2A		Jan 21/2005	152
			3A		Jan 21/2005	153-155
			4A		Jan 21/2005	156-157 166-167
			5A		Jan 21/2005	162-165
			6		Jan 21/2005	277-299
SATCOM ADDRESS CODING	23-25-15		1A		Jan 21/2005	150 153-155
			2A		Jan 21/2005	156-157 166-167
			3A		Jan 21/2005	162-164
			4A		Jan 21/2005	165
			5		Jan 21/2005	277-299

23-CONTENTS



767-200/300

WIRING DIAGRAM MANUAL

CHAPTER 23
COMMUNICATIONS

Title	CH-SC-SU	Schem	Page	Sheet	Date	Effectivity
SATCOM SYSTEM- TOP MOUNTED HGA SYSTEM	23-25-16		1A		Jan 21/2005	150 153-155
			2A		Jan 21/2005	156-157 166
			3A		Jan 21/2005	162-165
			4A		Jan 21/2005	167
			5		Jan 21/2005	277-299
SATCOM SYSTEM- SIDE-MOUNTED HGA SUBSYSTEM	23-25-17		1A	1	Jan 21/2005	150 153-155
				2	Jan 21/2005	150 153-155
			2A	1	Jan 21/2005	156-157 166-167
				2	Jan 21/2005	156-157 166-167
			3A	1	Jan 21/2005	162-165
				2	Jan 21/2005	162-165
			4	1	Jan 21/2005	277-299
				2	Jan 21/2005	277-299
PASSENGER ADDRESS SYSTEM						
PASSENGER ADDRESS- VOICE INPUT CIRCUITRY	23-31-11		1A		Jan 21/2005	050-051
			2.1A		Jan 21/2005	150 152
			3.1A		Jan 21/2005	151
			4.1A		Jan 21/2005	153-154
			5A		Jan 21/2005	155-167
			6.1		Jan 21/2005	275
			7.1A		Jan 21/2005	276
			8		Jan 21/2005	277-278
			9		Jan 21/2005	280-299
PASSENGER ADDRESS- BOARDING MUSIC/ PRE-RECORD ANN. & ATTEND. PANEL	23-31-12		1A		Jan 21/2005	050-051
				2	Jan 21/2005	150-199
				3	Jan 21/2005	275-278
				4	Jan 21/2005	280-299

23-CONTENTS

Page 5
Jun 28/2006

D280T132



767-200/300

WIRING DIAGRAM MANUAL

**CHAPTER 23
COMMUNICATIONS**

Title	CH-SC-SU	Schem	Page	Sheet	Date	Effectivity
PASSENGER ADDRESS- OUTPUT CIRCUITRY & CONTROLS	23-31-13		1A	1	Jan 21/2005	050
				2	Jan 21/2005	050
			2A		Jan 21/2005	051
			3A	1	Jan 21/2005	150 154
				2	Jan 21/2005	150 154
			4A		Jan 21/2005	151-153
			5A	1	Jan 21/2005	155
				2	Jan 21/2005	155
			6A	1	Jan 21/2005	156-157 167
				2	Jan 21/2005	156-157 167
			7A	1	Jan 21/2005	162-165
				2	Jan 21/2005	162-165
			8A	1	Jan 21/2005	166
				2	Jan 21/2005	166
				9	Jan 21/2005	275-299
PASSENGER ADDRESS- SPEAKERS-ATTENDANT, GALLEY & LAVATORY	23-31-14		1A	1	Jan 21/2005	050
				2	Jan 21/2005	050
			2A	1	Jan 21/2005	051
				2	Jan 21/2005	051
			3A	1	Jan 21/2005	150 154-167
				2	Jan 21/2005	150 154-167
			4A	1	Jan 21/2005	151-153
				2	Jan 21/2005	151-153
			5		Jan 21/2005	275-278
			6		Jan 21/2005	280-299
PASSENGER ADDRESS- SPEAKERS- LEFT PSU SECTION	23-31-15		1	1	Jan 21/2005	050-099
				2	Jan 21/2005	050-099
			2	1	Jan 21/2005	150-199
				2	Jan 21/2005	150-199

23-CONTENTS

Page 6
Jun 28/2006

D280T132



767-200/300

WIRING DIAGRAM MANUAL

CHAPTER 23
COMMUNICATIONS

Title	CH-SC-SU	Schem	Page	Sheet	Date	Effectivity	
PASSENGER ADDRESS-SPEAKERS- LEFT PSU SECTION (cont.)	23-31-15		3		Jan 21/2005	275-278	
			4		Jan 21/2005	280-299	
PASSENGER ADDRESS-SPEAKERS- CENTER PSU SECTION	23-31-16		1	1	Jan 21/2005	050-099	
				2	Jan 21/2005	050-099	
			2	1	Jan 21/2005	150-199	
				2	Jan 21/2005	150-199	
				3	Jan 21/2005	275	
				4	Jan 21/2005	276-278	
				5	1	Jan 21/2005	280-299
				2	Jan 21/2005	280-299	
PASSENGER ADDRESS-SPEAKERS- RIGHT PSU SECTION	23-31-17		1	1	Jan 21/2005	050-099	
				2	Jan 21/2005	050-099	
			2	1	Jan 21/2005	150-199	
				2	Jan 21/2005	150-199	
				3	Jan 21/2005	275-278	
				4	Jan 21/2005	280-299	
<u>PASSENGER ENTERTAINMENT (VIDEO PROJECTION)</u>							
VIDEO PROJECTION-POWER	23-32-11		1A		Jan 21/2005	050-051	
			2A		Jan 21/2005	150 153-154 162-165	
			3A		Jan 21/2005	151	
			4A		Jan 21/2005	152	
			5A		Jan 21/2005	155	
			6A		Jan 21/2005	156-157 166-167	
			7		Jan 21/2005	275-276	
			8		Jan 21/2005	277-278	
			9		Jan 21/2005	280-299	
VIDEO PROJECTION- AUDIO	23-32-12		1A	1	Jan 21/2005	050-051	
				2	Jan 21/2005	050-051	
			2A	1	Jan 21/2005	150 153-154	

23-CONTENTS



767-200/300

WIRING DIAGRAM MANUAL

**CHAPTER 23
COMMUNICATIONS**

Title	CH-SC-SU	Schem	Page	Sheet	Date	Effectivity	
VIDEO PROJECTION- AUDIO (cont.)	23-32-12			2	Jan 21/2005	150 153-154	
			3A	1	Jan 21/2005	151	
				2	Jan 21/2005	151	
			4A	1	Jan 21/2005	152	
				2	Jan 21/2005	152	
			5A	1	Jan 21/2005	155-167	
				2	Jan 21/2005	155-167	
			6		Jan 21/2005	275	
			7		Jan 21/2005	276-299	
		VIDEO PROJECTION- DISTRIBUTION	23-32-13		1A	1	Jan 21/2005
				2	Jan 21/2005	050-051	
	2A			1	Jan 21/2005	150 153-157	
				2	Jan 21/2005	150 153-157	
				3	Jan 21/2005	150 153-157	
	3			1	Jan 21/2005	151	
				2	Jan 21/2005	151	
	4A			1	Jan 21/2005	152	
				2	Jan 21/2005	152	
	5A			1	Jan 21/2005	162-167	
				2	Jan 21/2005	162-167	
				3	Jan 21/2005	162-167	
				4	Jan 21/2005	162-167	
	6				Jan 21/2005	275	
	7				Jan 21/2005	276-299	
VIDEO PROJECTION PASSENGER ENROUTE DISPLAY SYSTEM	23-32-21		1A		Jan 21/2005	050-051	
				2A	1	Jan 21/2005	150 153-154
					2	Jan 21/2005	150 153-154
				3		Jan 21/2005	151
			4A	1	Jan 21/2005	152	
				2	Jan 21/2005	152	
			5A	1	Jan 21/2005	155-156 162-167	

23-CONTENTS



767-200/300

WIRING DIAGRAM MANUAL

**CHAPTER 23
COMMUNICATIONS**

Title	CH-SC-SU	Schem	Page	Sheet	Date	Effectivity	
VIDEO PROJECTION PASSENGER ENROUTE DISPLAY SYSTEM (cont.)	23-32-21			2	Jan 21/2005	155-156 162-167	
				6A	1	Jan 21/2005	157
					2	Jan 21/2005	157
				7		Jan 21/2005	275
				8		Jan 21/2005	276-278
				9		Jan 21/2005	280-299
VIDEO ENTERTAINMENT SYSTEM- VIDEO-1	23-32-31			1	Jan 21/2005	275	
				2	Jan 21/2005	276-299	
VIDEO ENTERTAINMENT SYSTEM- VIDEO-1	23-32-32			1	Jan 21/2005	275-278	
				2	Jan 21/2005	280-299	
VIDEO ENTERTAINMENT SYSTEM- VIDEO 1	23-32-33			1	Jan 21/2005	275-299	
VIDEO ENTERTAINMENT SYSTEM- VIDEO 1	23-32-34			1	Jan 21/2005	275-278	
				2	Jan 21/2005	280-299	
VIDEO ENTERTAINMENT SYSTEM- VIDEO 2	23-32-41			1	Jan 21/2005	275-299	
VIDEO ENTERTAINMENT SYSTEM- VIDEO 2	23-32-42			1	Jan 21/2005	275-299	
VIDEO ENTERTAINMENT SYSTEM- VIDEO 2	23-32-43			1	Jan 21/2005	275-278	
				2	Jan 21/2005	280-299	
VIDEO ENTERTAINMENT SYSTEM- VIDEO 1	23-32-44			1	Jan 21/2005	280-299	
VIDEO ENTERTAINMENT SYSTEM- VIDEO 3	23-32-51			1	Jan 21/2005	275	
				2	Jan 21/2005	276-299	
VIDEO ENTERTAINMENT SYSTEM- VIDEO 3	23-32-52			1	Jan 21/2005	275-299	
VIDEO ENTERTAINMENT SYSTEM- VIDEO 3	23-32-53			1	Jan 21/2005	275-299	
VIDEO ENTERTAINMENT SYSTEM- VIDEO 3	23-32-54			1	Jan 21/2005	280-299	
VIDEO ENTERTAINMENT SYSTEM- VIDEO 4	23-32-61			1	Jan 21/2005	275-299	

23-CONTENTS



767-200/300

WIRING DIAGRAM MANUAL

CHAPTER 23
COMMUNICATIONS

Title	CH-SC-SU	Schem	Page	Sheet	Date	Effectivity
VIDEO ENTERTAINMENT SYSTEM- VIDEO 4	23-32-62		1		Jan 21/2005	275-299
<u>PASSENGER ENTERTAINMENT/PASSENGER SERVICE SYSTEM</u>						
PASSENGER ENTERTAINMENT PASSENGER SERVICE	23-34-11		1		Jan 21/2005	050-099
			2		Jan 21/2005	150-199
			3		Jan 21/2005	275-278
			4		Jan 21/2005	280-299
PASSENGER ENTERTAINMENT PASSENGER SERVICE	23-34-12		1		Jan 21/2005	050-099
			2		Jan 21/2005	150-199 275-299
PASSENGER ENTERTAINMENT PASSENGER SERVICE	23-34-13		1		Jan 21/2005	050-099
			2		Jan 21/2005	150
			3		Jan 21/2005	151-154 156
			4		Jan 21/2005	155
			5		Jan 21/2005	157
			6		Jan 21/2005	162-199
			7	1	Jan 21/2005	275-276
				2	Jan 21/2005	275-276
			7.1	1	Jan 21/2005	275-276
				2	Jan 21/2005	275-276
			8	1	Jan 21/2005	277-278
		2	Jan 21/2005	277-278		
	9	1	Jan 21/2005	280-299		
		2	Jan 21/2005	280-299		
PASSENGER ENTERTAINMENT PASSENGER SERVICE	23-34-14		1A		Jan 21/2005	050-051
			2A		Jan 21/2005	150-154
			3		Jan 21/2005	155-199
			4		Jan 21/2005	275-278
			5		Jan 21/2005	280-299

23-CONTENTS

Page 10
Jun 28/2006

D280T132



767-200/300

WIRING DIAGRAM MANUAL

CHAPTER 23
COMMUNICATIONS

Title	CH-SC-SU	Schem	Page	Sheet	Date	Effectivity
PASSENGER ENTERTAINMENT PASSENGER SERVICE	23-34-15		1	1	Aug 05/2009	050-099
				2	Jan 21/2005	050-099
			2		Jan 21/2005	150-157
			3	1	Aug 05/2009	162-199
				2	Jan 21/2005	162-199
				3	Jan 21/2005	162-199
			4		Jan 21/2005	275
			5		Jan 21/2005	276-278
			6		Aug 05/2009	280-299
			PASSENGER ENTERTAINMENT PASSENGER SERVICE	23-34-16		1
2		Jan 21/2005				150-199
3		Jan 21/2005				275
4		Jan 21/2005				276-278
5		Aug 05/2009				280-299
PASSENGER ENTERTAINMENT PASSENGER SERVICE	23-34-17		1		Jan 21/2005	050-099
			2		Jan 21/2005	150-199
			3		Jan 21/2005	275-278
			4		Aug 05/2009	280-299
PASSENGER ENTERTAINMENT PASSENGER SERVICE	23-34-18		1		Jan 21/2005	050-099
			2		Jan 21/2005	150-199 275-299
PASSENGER ENTERTAINMENT PASSENGER SERVICE	23-34-19		1		Jan 21/2005	050-099
			2		Jan 21/2005	150-199
			3		Jan 21/2005	275-278
			4		Jan 21/2005	280-299
<u>SERVICE INTERPHONE SYSTEM</u>						
SERVICE INTERPHONE	23-41-11		1		Jan 21/2005	050-099 155-157 277-299
			2		Jan 21/2005	150-154

23-CONTENTS

Page 11
Aug 05/2009

D280T132



767-200/300

WIRING DIAGRAM MANUAL

CHAPTER 23
COMMUNICATIONS

Title	CH-SC-SU	Schem	Page	Sheet	Date	Effectivity
SERVICE INTERPHONE (cont.)	23-41-11		3		Jan 21/2005	162-199
			4.1		Jan 21/2005	275-276
<u>CABIN INTERPHONE SYSTEM</u>						
CABIN INTERPHONE SYSTEM	23-42-11		1A	1	Jan 21/2005	050-051
				2	Jan 21/2005	050-051
				3	Jan 21/2005	050-051
			2	1	Jan 21/2005	150
				2	Jan 21/2005	150
			3	1	Jan 21/2005	151-154 156
				2	Jan 21/2005	151-154 156
			4	1	Jan 21/2005	155
				2	Jan 21/2005	155
			5	1	Jan 21/2005	157
				2	Jan 21/2005	157
			6	1	Jan 21/2005	162-199
				2	Jan 21/2005	162-199
				3	Jan 21/2005	162-199
			7		Jan 21/2005	275-276
			7.1		Jan 21/2005	275-276
			8		Jan 21/2005	277-278
9	1	Jan 21/2005	280-299			
	2	Jan 21/2005	280-299			
CABIN INTERPHONE SYSTEM- ELECTRONIC CHIME	23-42-12		1		Jan 21/2005	150-199
			2		Jan 21/2005	275-278
			3		Jan 21/2005	280-299
<u>GROUND CREW CALL SYSTEM</u>						
GROUND CREW CALL	23-43-11		1		Jan 21/2005	050-099 155-199 277-299
			2		Jan 21/2005	150-154
			3.1		Jan 21/2005	275-276

23-CONTENTS

Page 12
Jun 28/2006

D280T132



767-200/300

WIRING DIAGRAM MANUAL

CHAPTER 23 COMMUNICATIONS

Title	CH-SC-SU	Schem	Page	Sheet	Date	Effectivity
<u>FLIGHT INTERPHONE SYSTEM</u>						
FLIGHT INTERPHONE- CAPTAIN- PART A	23-51-11		1		Jan 21/2005	050-099 155-199
			2.1A		Jan 21/2005	150
			3.1		Jan 21/2005	151-152
			4		Jan 21/2005	153-154
			5.1		Jan 21/2005	275-276
			6		Jan 21/2005	277-299
FLIGHT INTERPHONE- CAPTAIN- PART B	23-51-12		1		Jan 21/2005	050-099 150-199
			2		Jan 21/2005	275-276
			3		Jan 21/2005	277-299
FLIGHT INTERPHONE- CAPTAIN- PART C	23-51-13		1		Jan 21/2005	050-099 150-199
			2		Jan 21/2005	275-299
FLIGHT INTERPHONE- CAPTAIN- PART D	23-51-14		1		Jan 21/2005	050-099 151-152 275-276
			2A		Jan 21/2005	150 153-155
			3		Jan 21/2005	156-157 166-199 277-299
			4A		Jan 21/2005	162-165
FLIGHT INTERPHONE- FIRST OFFICER	23-51-21		1		Jan 21/2005	050-099 153-199
			2.1A		Jan 21/2005	150
			3.1		Jan 21/2005	151-152
			4		Jan 21/2005	275-299
FLIGHT INTERPHONE- FIRST OBSERVER	23-51-41		1		Jan 21/2005	050-099 153-199
			2.1		Jan 21/2005	150-152
			3		Jan 21/2005	275-299
<u>VOICE RECORDER SYSTEM</u>						
VOICE RECORDER	23-71-11		1		Jan 21/2005	ALL



767-200/300

WIRING DIAGRAM MANUAL

CHAPTER 23 COMMUNICATIONS

CH-SC-SU	Title
23-22-13	ACARS CODING
23-22-12	ACARS, DFDAU, FLIGHT MANAGEMENT COMPUTER INTERFACE
23-22-15	ACARS- DATA LOADER INTERFACE
23-22-11	ACARS- POWER CONTROL & OOOI
23-19-11	AIR-TO-GROUND PUBLIC TELEPHONE
23-42-11	CABIN INTERPHONE SYSTEM
23-42-12	CABIN INTERPHONE SYSTEM- ELECTRONIC CHIME
23-24-11	EMERGENCY LOCATOR TRANSMITTER
23-51-11	FLIGHT INTERPHONE- CAPTAIN- PART A
23-51-12	FLIGHT INTERPHONE- CAPTAIN- PART B
23-51-13	FLIGHT INTERPHONE- CAPTAIN- PART C
23-51-14	FLIGHT INTERPHONE- CAPTAIN- PART D
23-51-41	FLIGHT INTERPHONE- FIRST OBSERVER
23-51-21	FLIGHT INTERPHONE- FIRST OFFICER
23-43-11	GROUND CREW CALL
23-11-11	HF COMMUNICATION- LEFT
23-11-21	HF COMMUNICATION- RIGHT
23-31-12	PASSENGER ADDRESS- BOARDING MUSIC/PRE-RECORD ANN. & ATTEND. PANEL
23-31-13	PASSENGER ADDRESS- OUTPUT CIRCUITRY & CONTROLS
23-31-16	PASSENGER ADDRESS- SPEAKERS- CENTER PSU SECTION
23-31-15	PASSENGER ADDRESS- SPEAKERS- LEFT PSU SECTION
23-31-17	PASSENGER ADDRESS- SPEAKERS- RIGHT PSU SECTION
23-31-14	PASSENGER ADDRESS- SPEAKERS-ATTENDANT, GALLEY & LAVATORY
23-31-11	PASSENGER ADDRESS- VOICE INPUT CIRCUITRY
23-34-11	PASSENGER ENTERTAINMENT PASSENGER SERVICE
23-34-12	PASSENGER ENTERTAINMENT PASSENGER SERVICE
23-34-13	PASSENGER ENTERTAINMENT PASSENGER SERVICE
23-34-14	PASSENGER ENTERTAINMENT PASSENGER SERVICE

23-ALPHABETICAL INDEX

D280T132

Page 1
Jan 21/2005



767-200/300

WIRING DIAGRAM MANUAL

CHAPTER 23 COMMUNICATIONS

CH-SC-SU	Title
23-34-15	PASSENGER ENTERTAINMENT PASSENGER SERVICE
23-34-16	PASSENGER ENTERTAINMENT PASSENGER SERVICE
23-34-17	PASSENGER ENTERTAINMENT PASSENGER SERVICE
23-34-18	PASSENGER ENTERTAINMENT PASSENGER SERVICE
23-34-19	PASSENGER ENTERTAINMENT PASSENGER SERVICE
23-25-15	SATCOM ADDRESS CODING
23-25-14	SATCOM SYSTEM- AUDIO INTERFACES
23-25-13	SATCOM SYSTEM- CONTROL INTERFACES
23-25-11	SATCOM SYSTEM- POWER & LGA SUBSYSTEM
23-25-12	SATCOM SYSTEM- RADIO FREQUENCY DISTRIBUTION
23-25-17	SATCOM SYSTEM- SIDE-MOUNTED HGA SUBSYSTEM
23-25-16	SATCOM SYSTEM- TOP MOUNTED HGA SYSTEM
23-21-11	SELCAL
23-21-12	SELCAL CODING
23-41-11	SERVICE INTERPHONE
23-12-31	VHF COMMUNICATION- CENTER
23-12-11	VHF COMMUNICATION- LEFT
23-12-21	VHF COMMUNICATION- RIGHT
23-32-33	VIDEO ENTERTAINMENT SYSTEM- VIDEO 1
23-32-34	VIDEO ENTERTAINMENT SYSTEM- VIDEO 1
23-32-44	VIDEO ENTERTAINMENT SYSTEM- VIDEO 1
23-32-41	VIDEO ENTERTAINMENT SYSTEM- VIDEO 2
23-32-42	VIDEO ENTERTAINMENT SYSTEM- VIDEO 2
23-32-43	VIDEO ENTERTAINMENT SYSTEM- VIDEO 2
23-32-51	VIDEO ENTERTAINMENT SYSTEM- VIDEO 3
23-32-52	VIDEO ENTERTAINMENT SYSTEM- VIDEO 3
23-32-53	VIDEO ENTERTAINMENT SYSTEM- VIDEO 3
23-32-54	VIDEO ENTERTAINMENT SYSTEM- VIDEO 3

23-ALPHABETICAL INDEX

D280T132

Page 2
Jan 21/2005



767-200/300

WIRING DIAGRAM MANUAL

CHAPTER 23 COMMUNICATIONS

CH-SC-SU	Title
23-32-61	VIDEO ENTERTAINMENT SYSTEM- VIDEO 4
23-32-62	VIDEO ENTERTAINMENT SYSTEM- VIDEO 4
23-32-31	VIDEO ENTERTAINMENT SYSTEM- VIDEO-1
23-32-32	VIDEO ENTERTAINMENT SYSTEM- VIDEO-1
23-32-21	VIDEO PROJECTION PASSENGER ENROUTE DISPLAY SYSTEM
23-32-12	VIDEO PROJECTION- AUDIO
23-32-13	VIDEO PROJECTION- DISTRIBUTION
23-32-11	VIDEO PROJECTION- POWER
23-71-11	VOICE RECORDER

23-ALPHABETICAL INDEX

D280T132

Page 3
Jan 21/2005

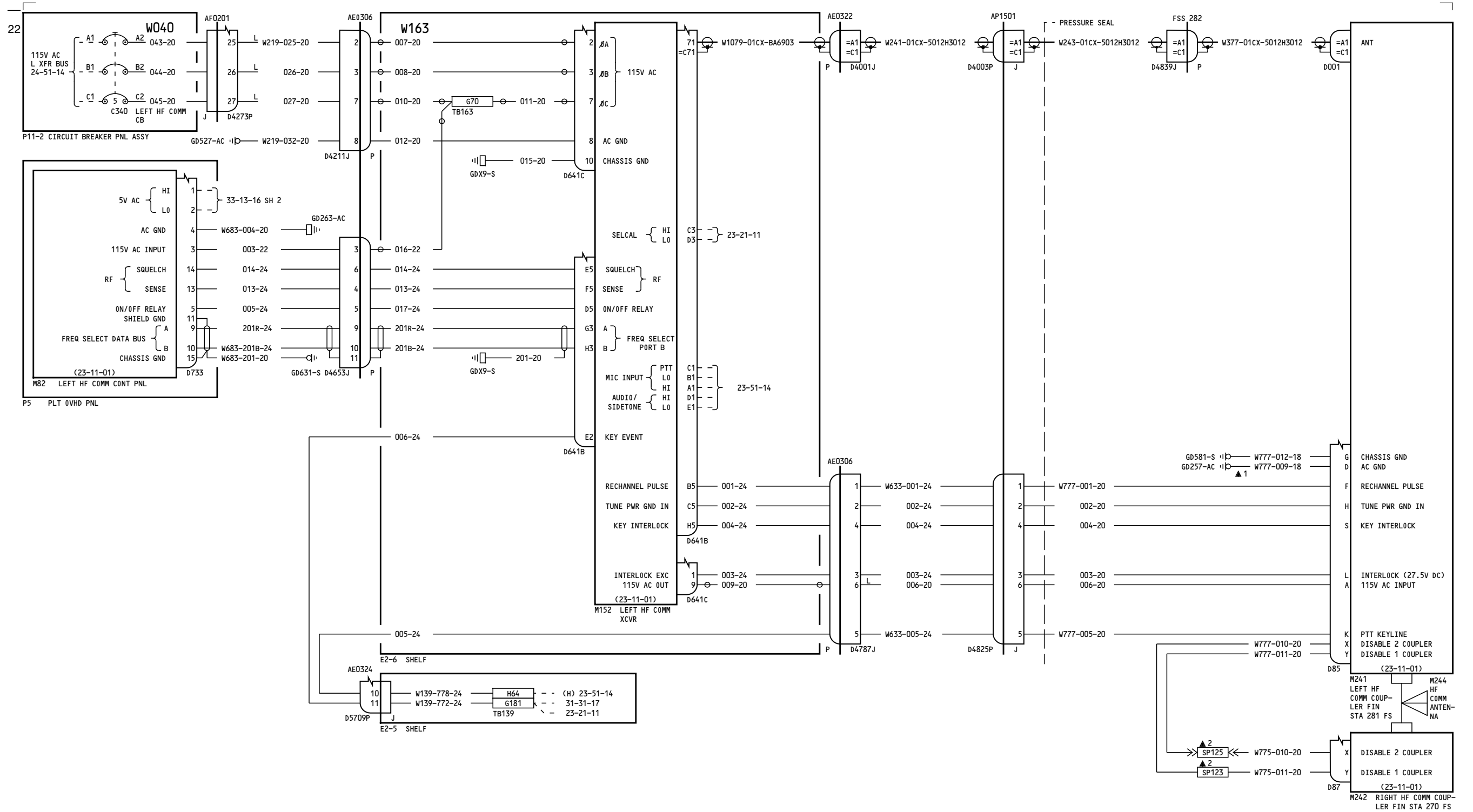

050-099, 150-154, 162-164, 275-276

HF COMMUNICATION-LEFT

23-11-11

Page 1

D280T132

Jan 21/2005

23-11-11

Page 1

Jan 21/2005

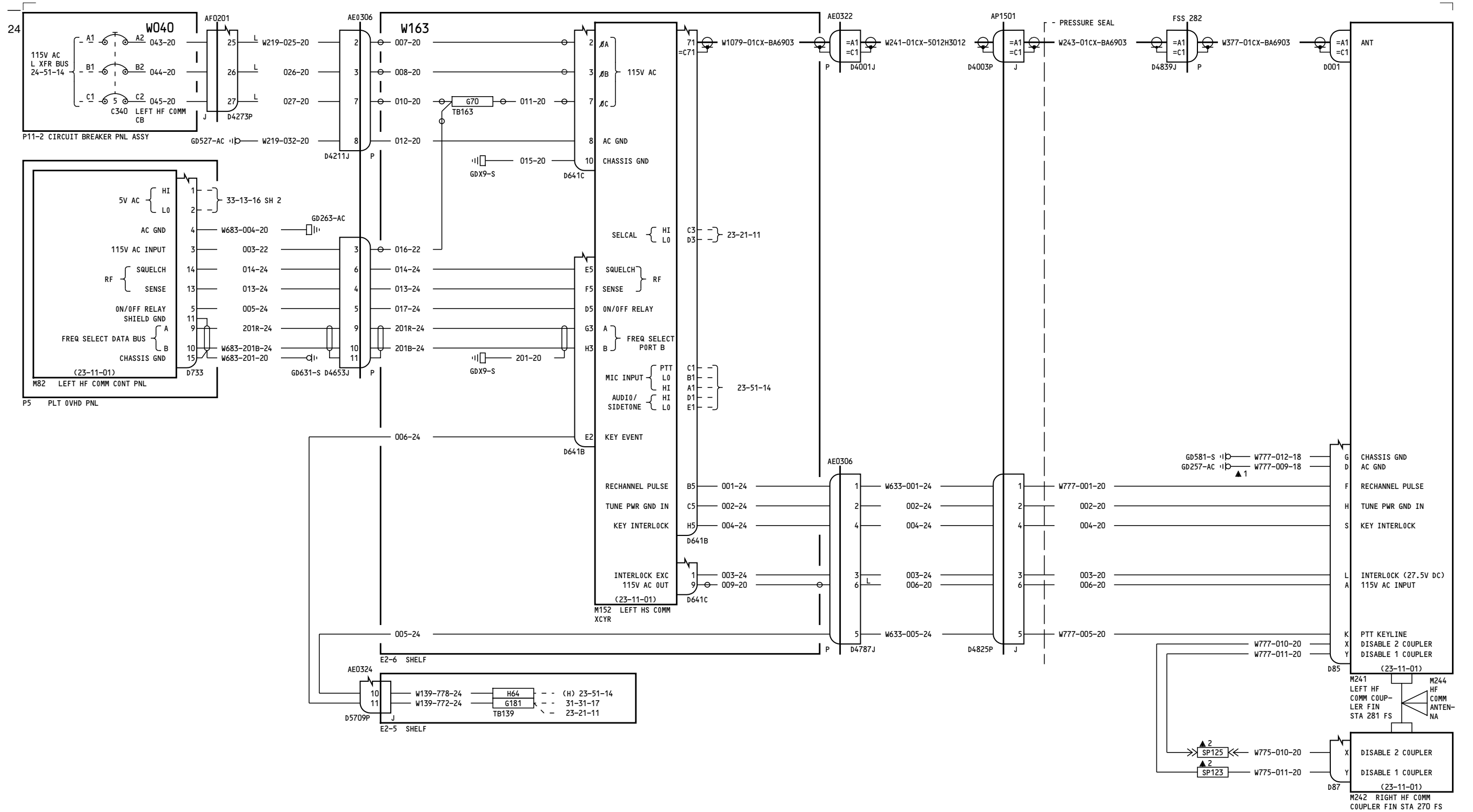

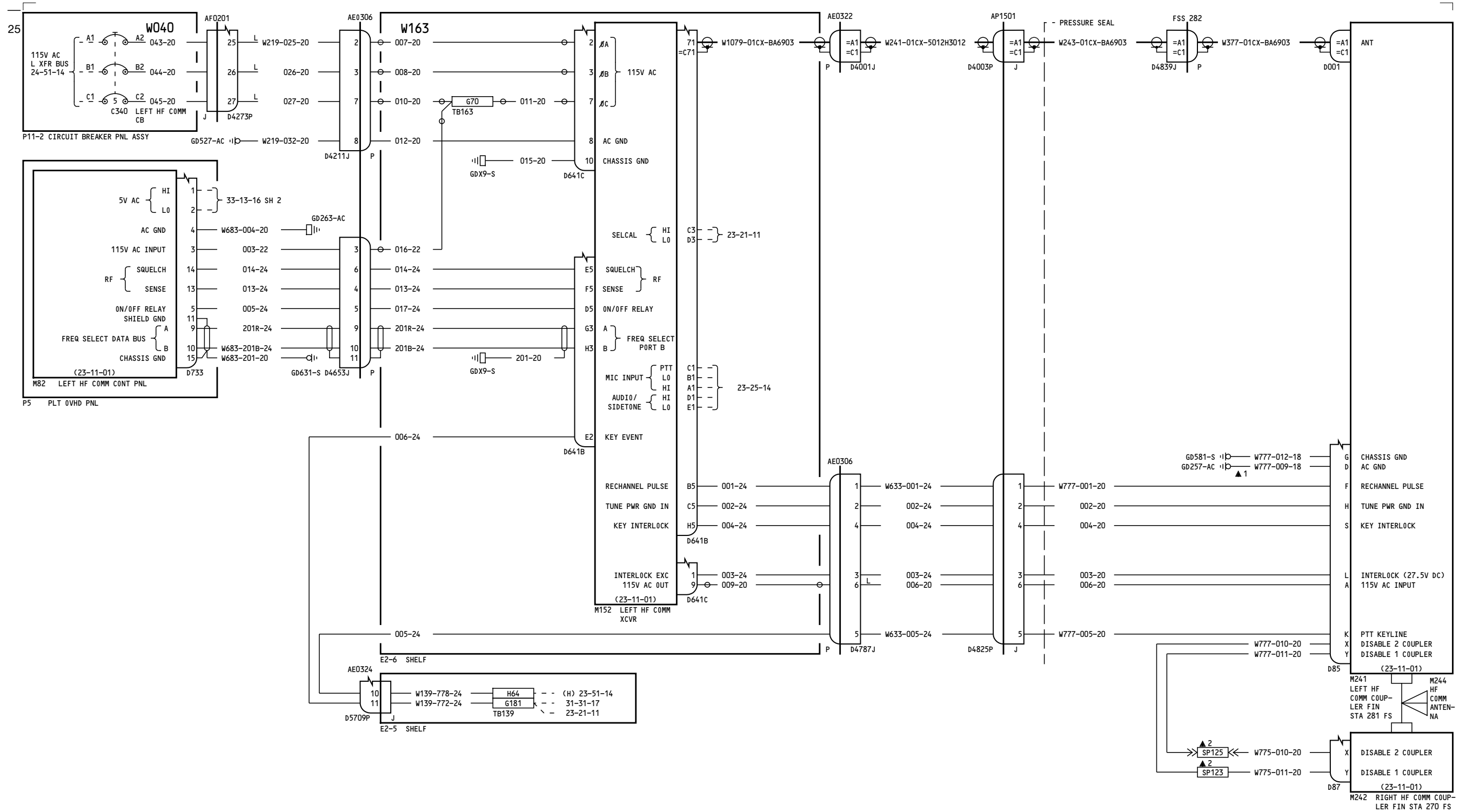

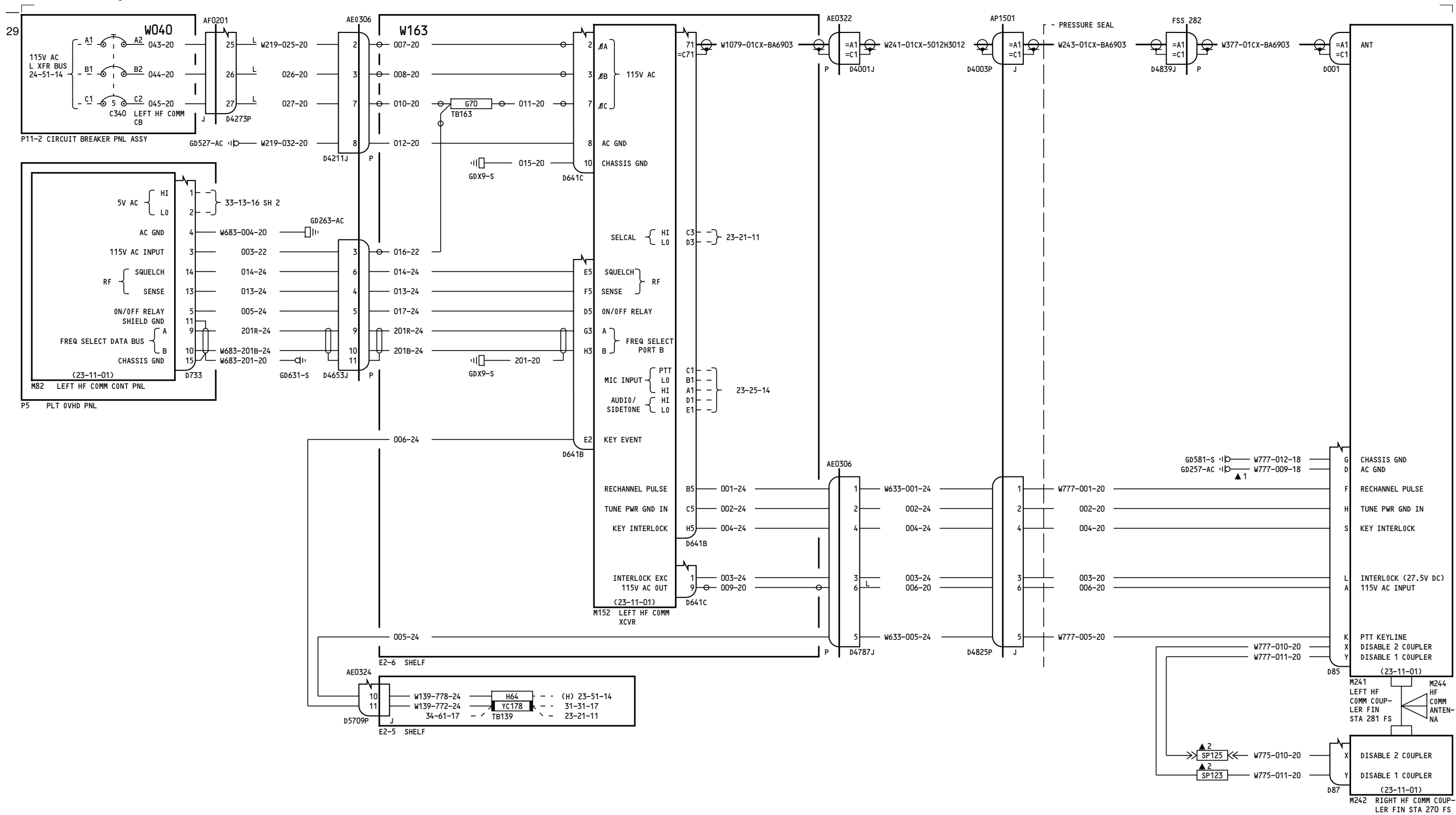

157, 167-199, 277-299

HF COMMUNICATION-LEFT

23-11-11

Page 4

D280T132

Jan 21/2005

23-11-11

Page 4

Jan 21/2005

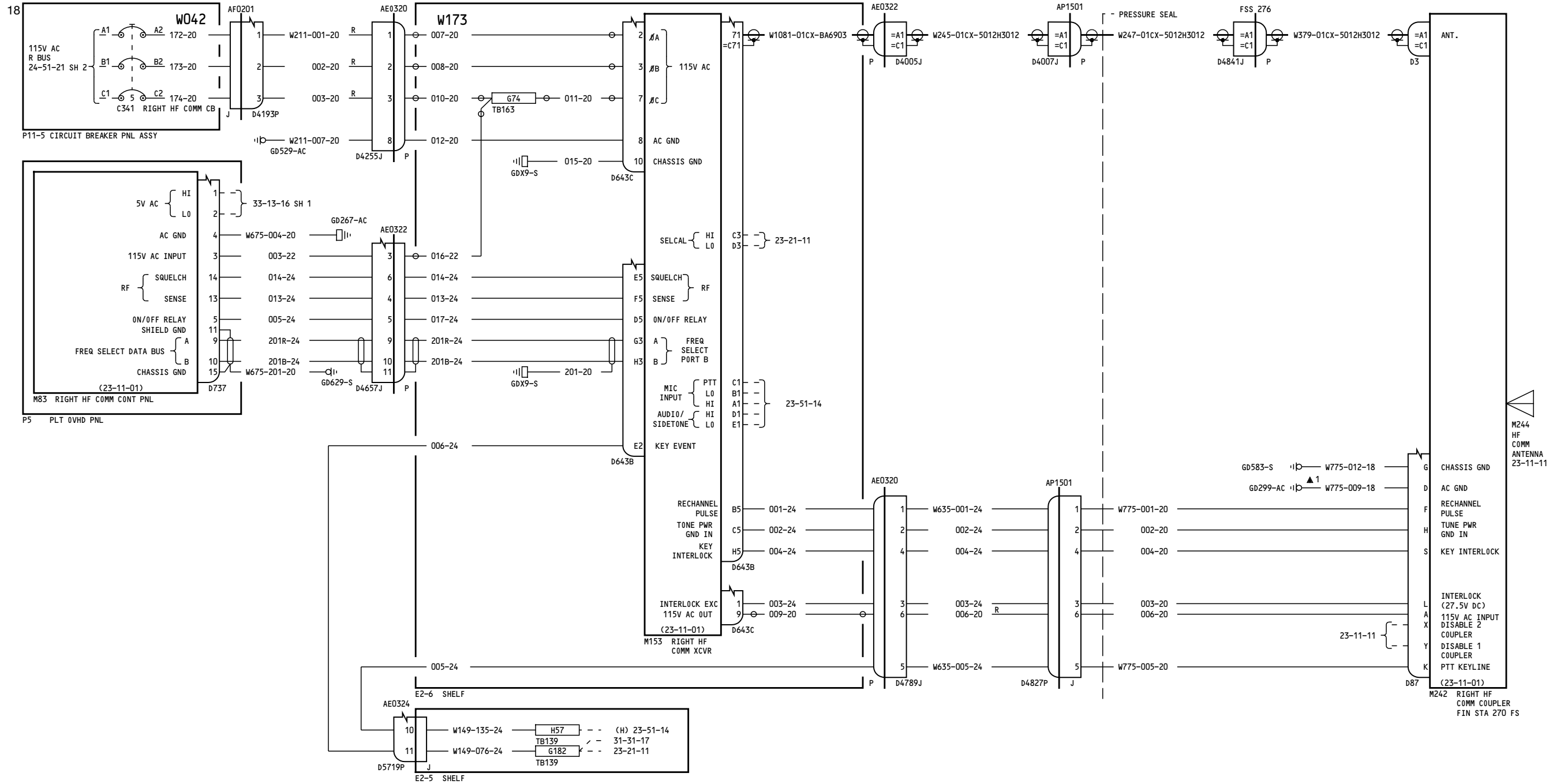

050-099, 150-154, 162-164, 275-276

HF COMMUNICATION-RIGHT

23-11-21

Page 1

D280T132

Jan 21/2005

23-11-21

Page 1

Jan 21/2005

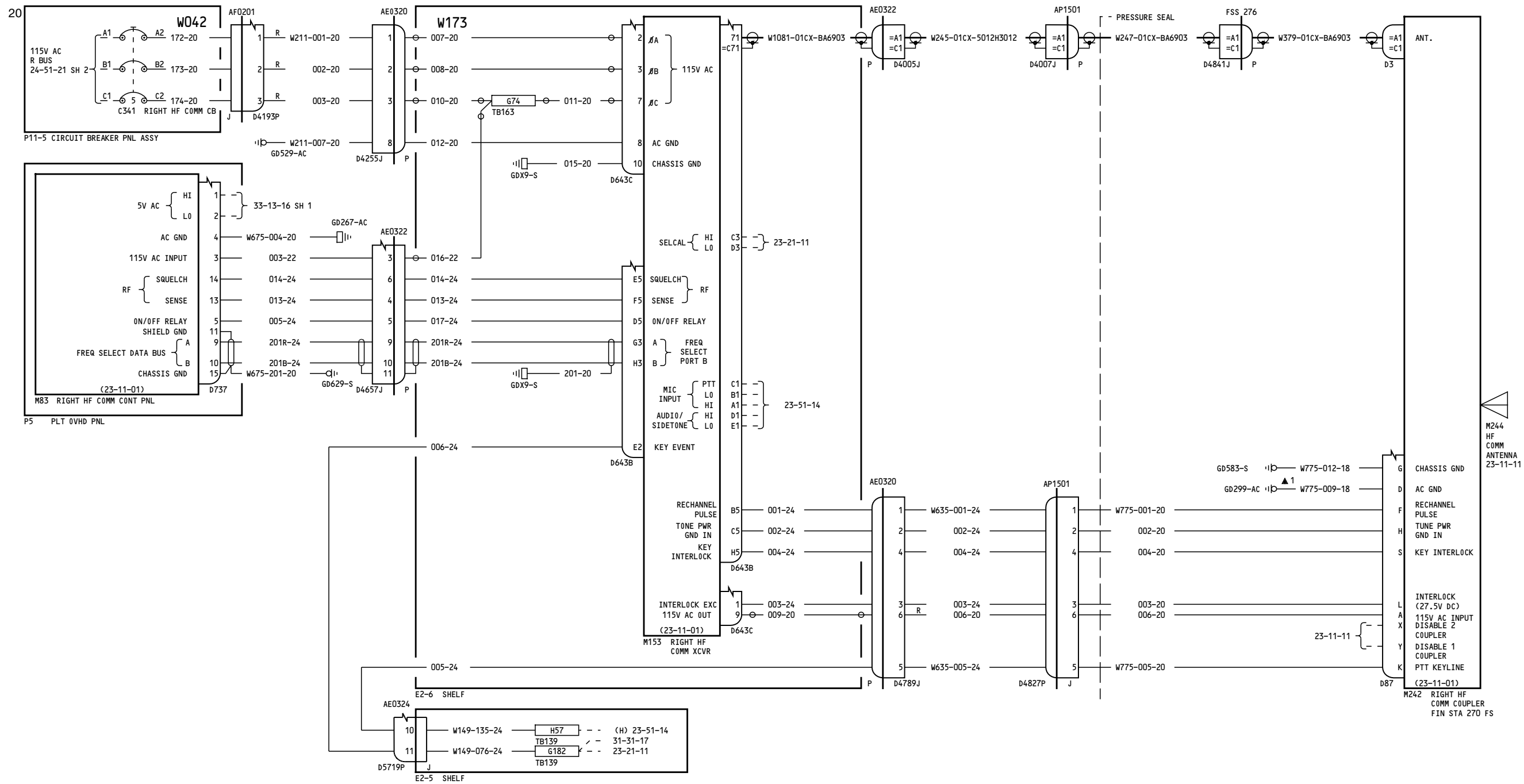

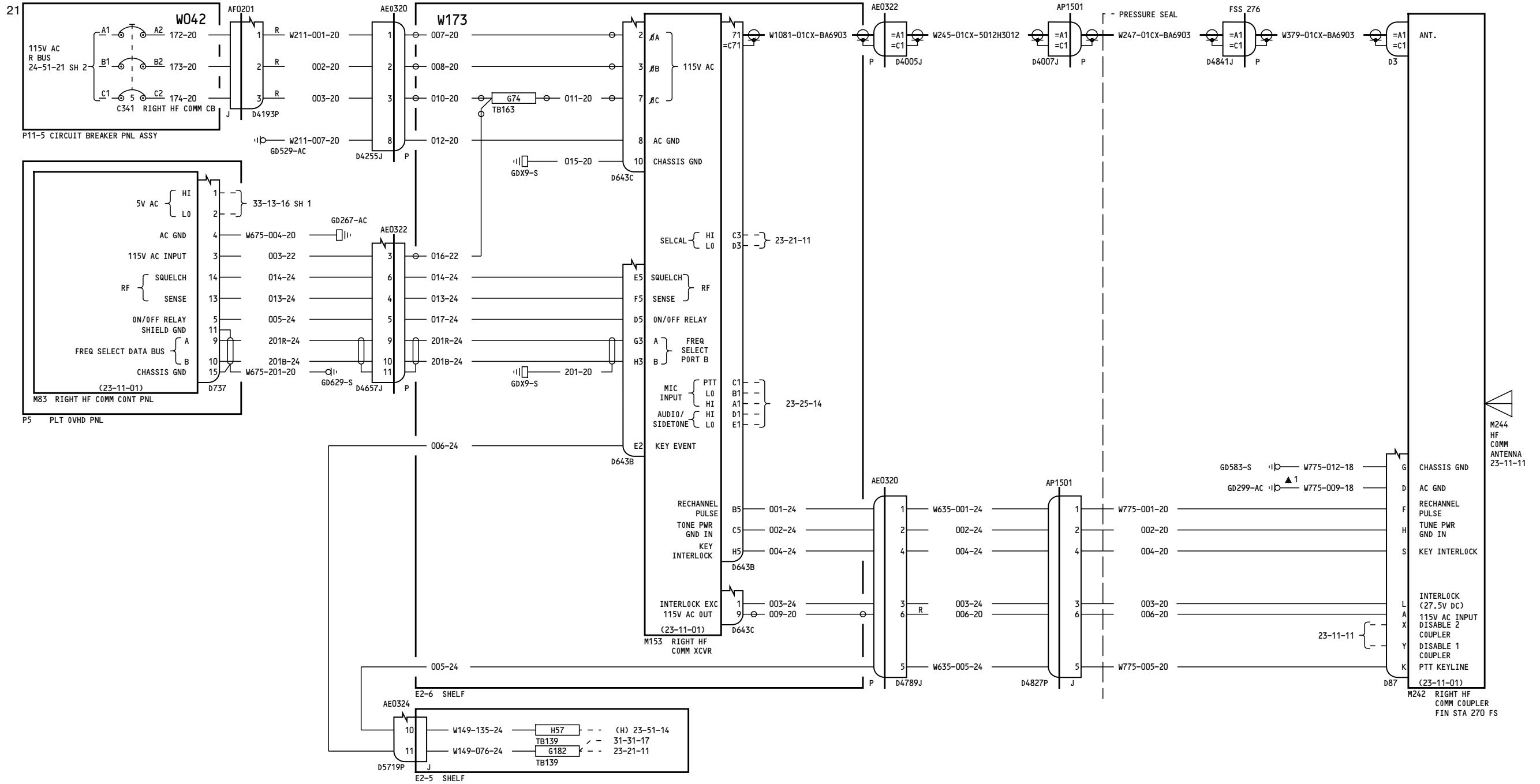

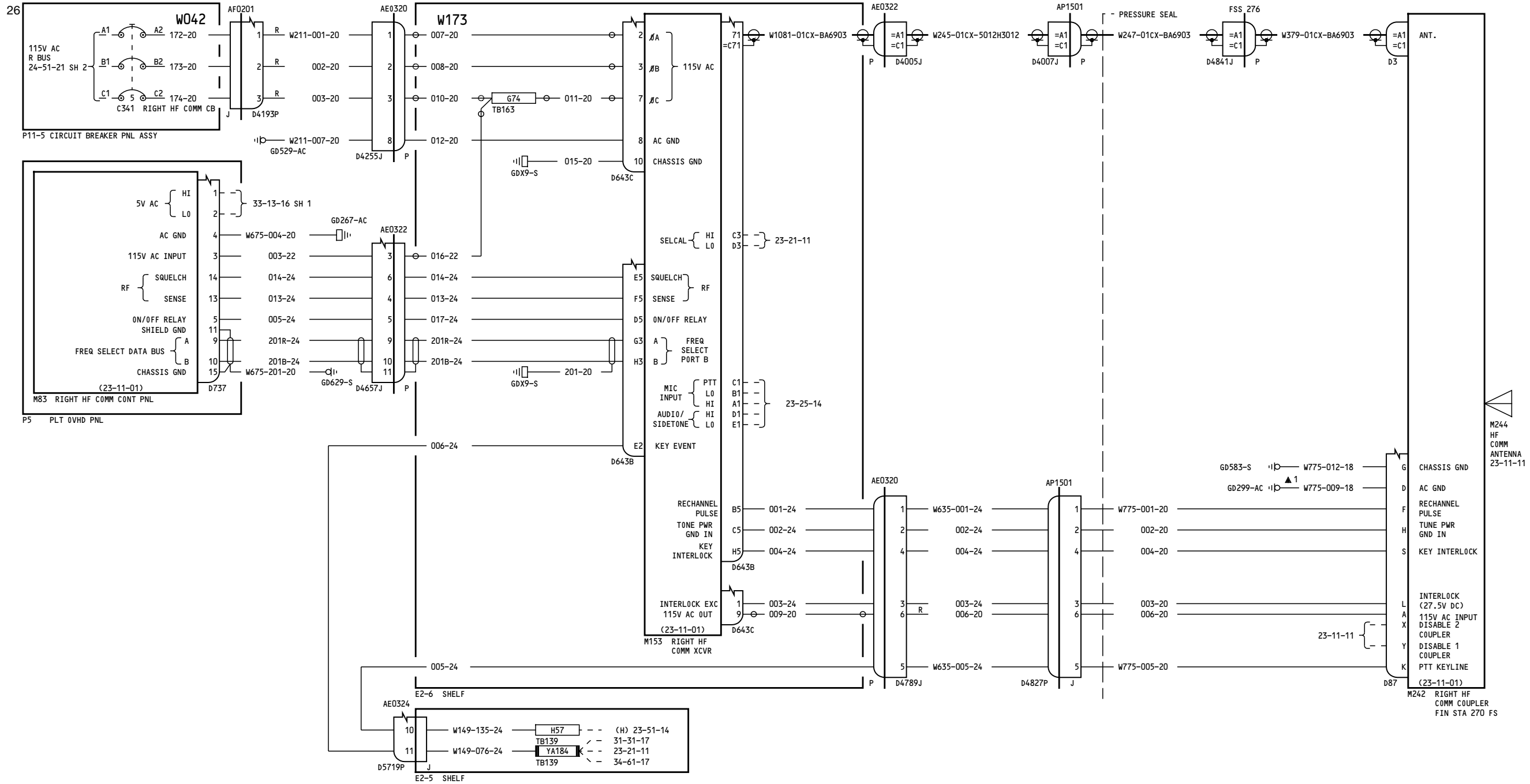

157, 167-199, 277-299

HF COMMUNICATION- RIGHT

23-11-21

Page 4

D280T132

Jan 21/2005

23-11-21

Page 4

Jan 21/2005

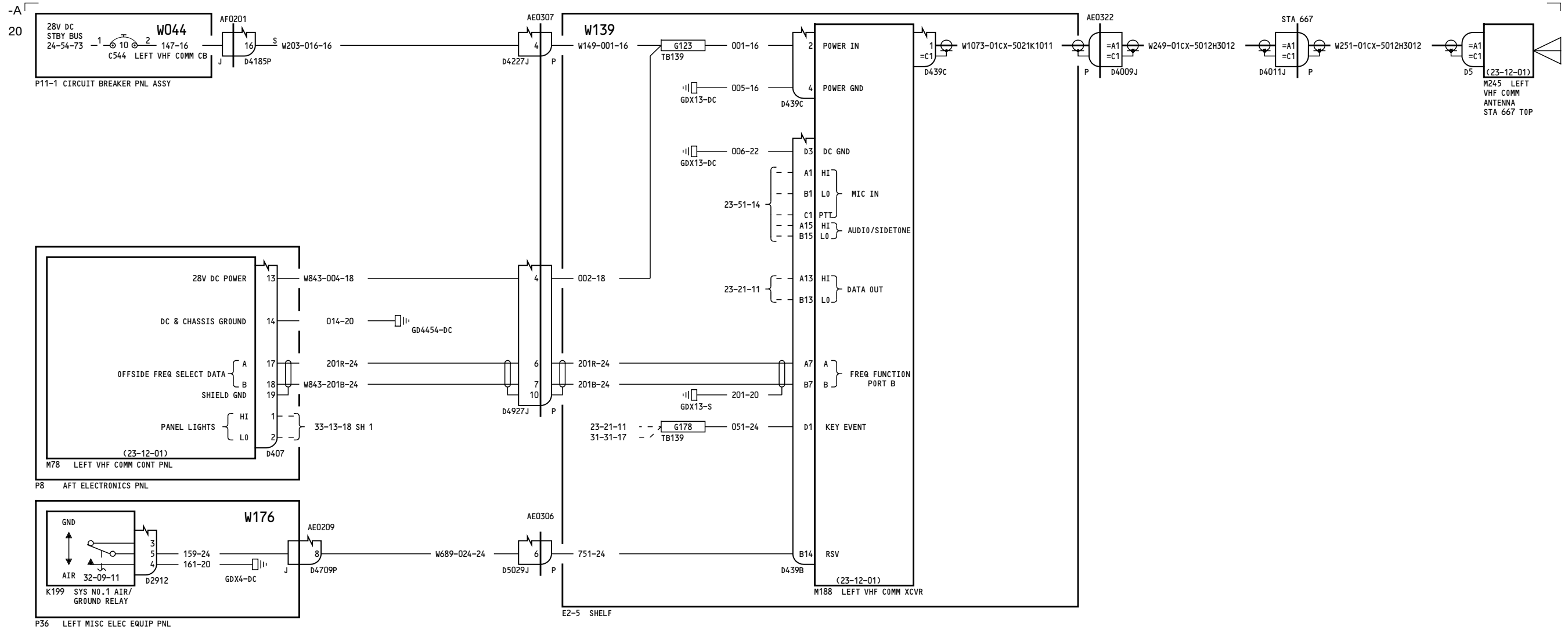

050-099

VHF COMMUNICATION-LEFT

23-12-11

Page 1

D280T132

Jan 21/2005

23-12-11

Page 1

Jan 21/2005

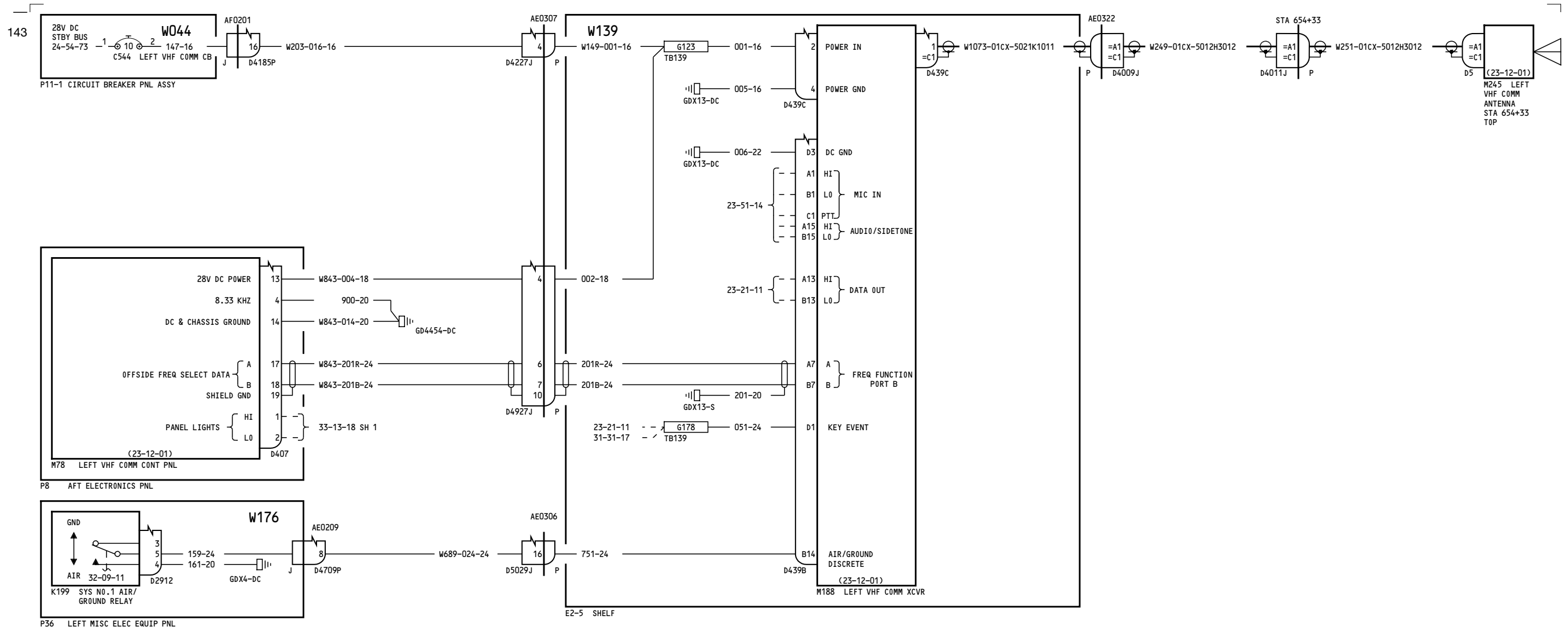

150, 152-156

VHF COMMUNICATION-LEFT

D280T132

23-12-11

Page 2A

Jan 21/2005

Incorporates
MTO-230731

23-12-11

Page 2A

Jan 21/2005

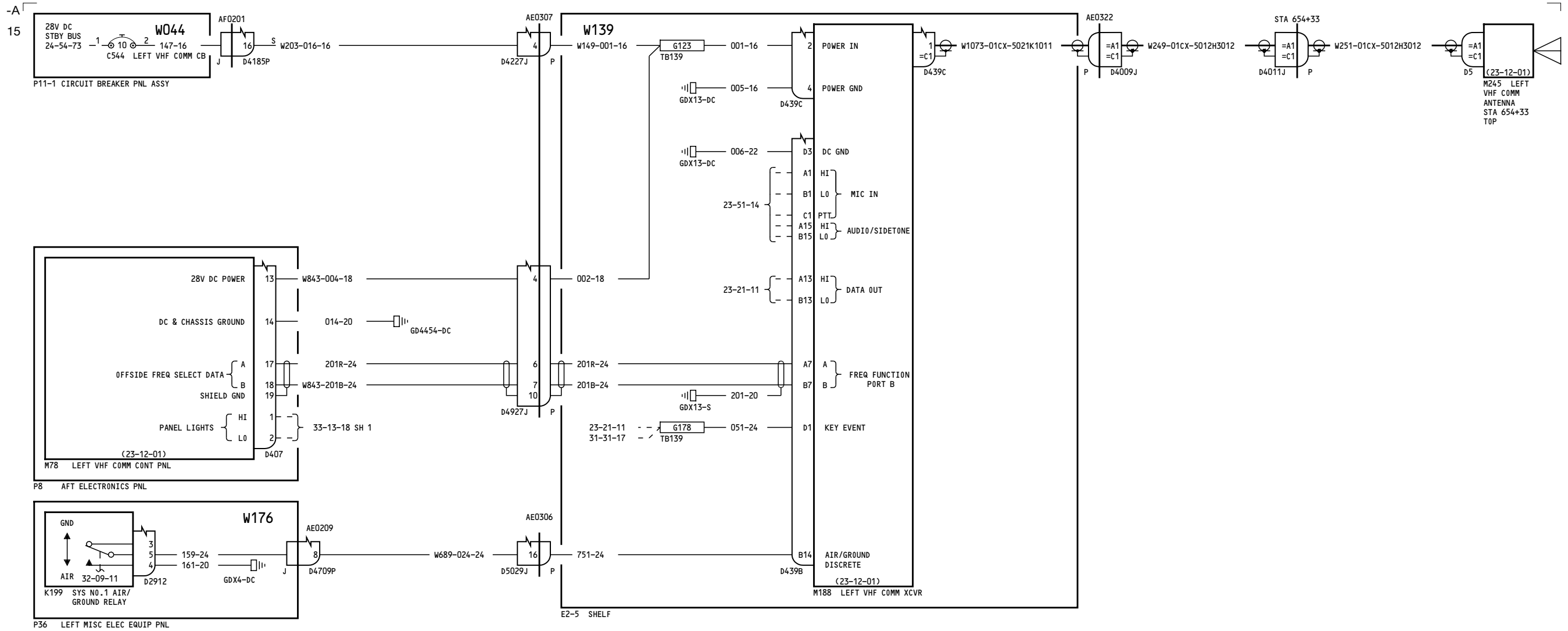

151	VHF COMMUNICATION-LEFT
	D280T132

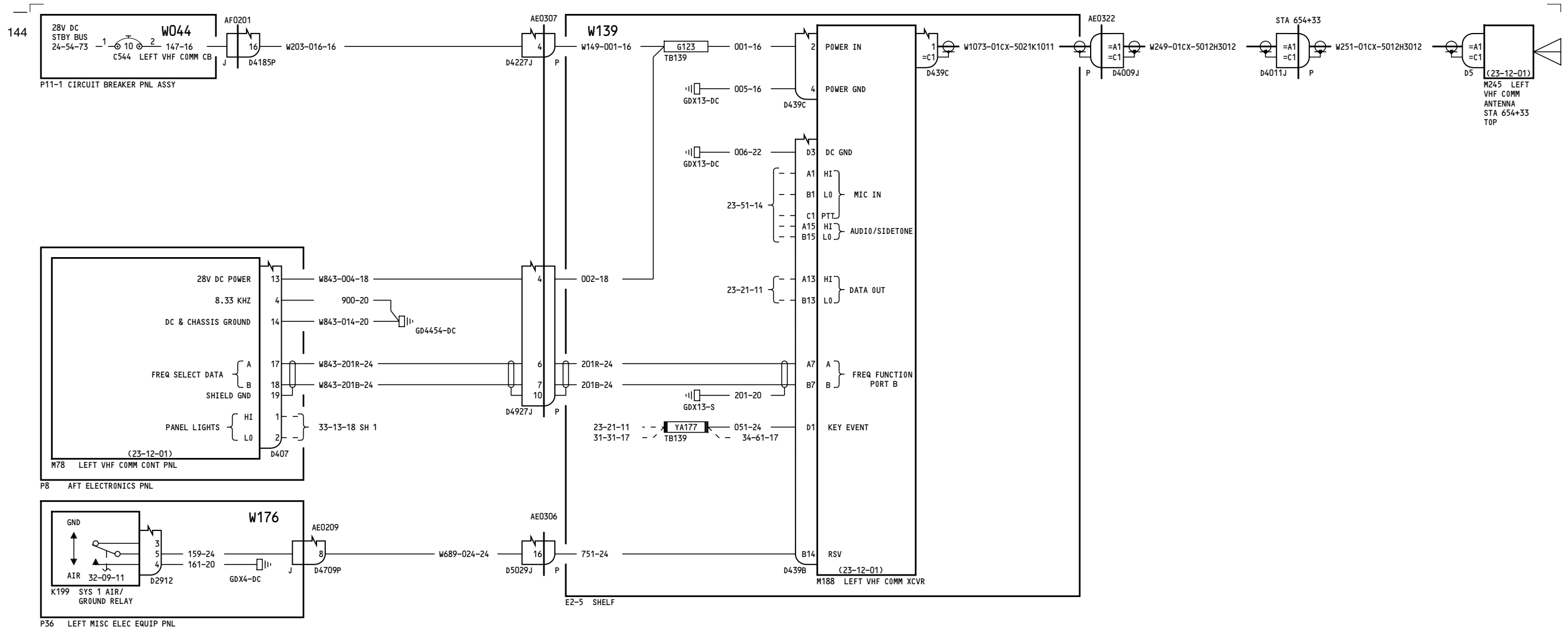

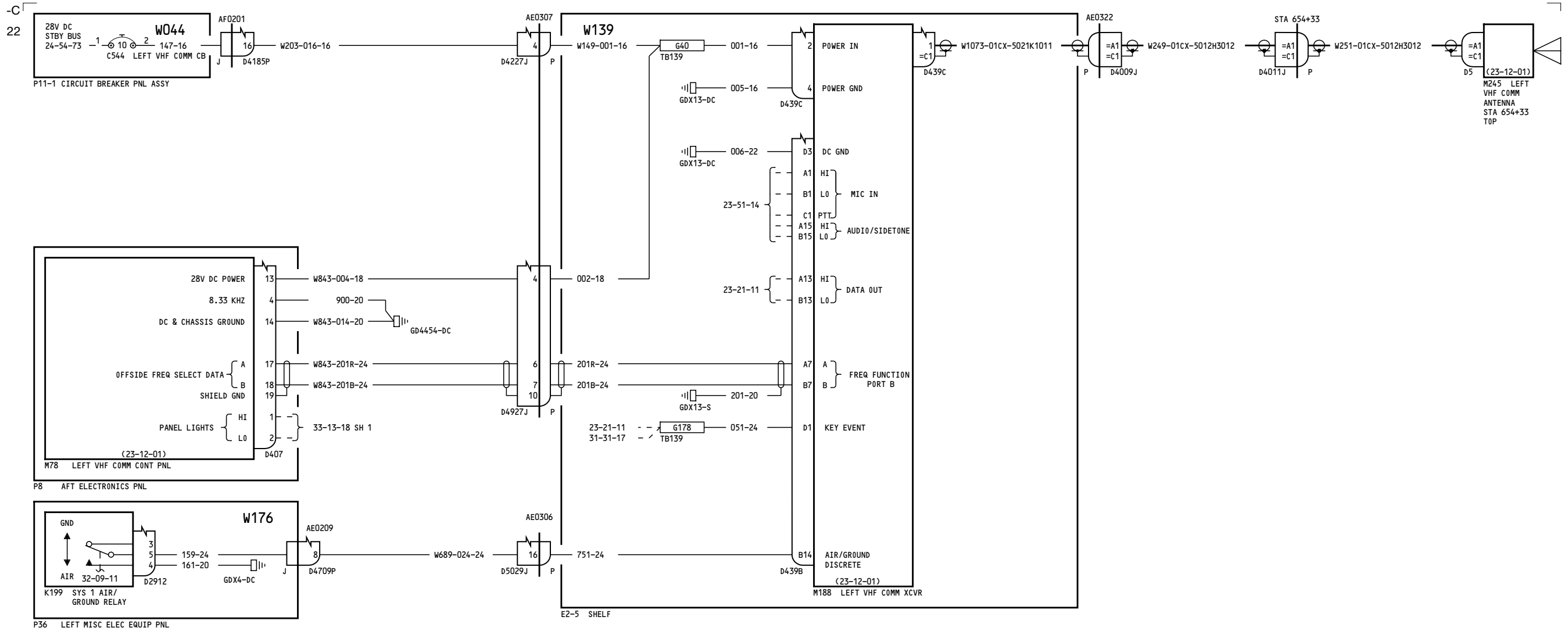

1 VN168-VN170

162-166

VHF COMMUNICATION-LEFT

D280T132

23-12-11

Page 5A

Jan 21/2005

Incorporates
MTO-230731

23-12-11

Page 5A

Jan 21/2005

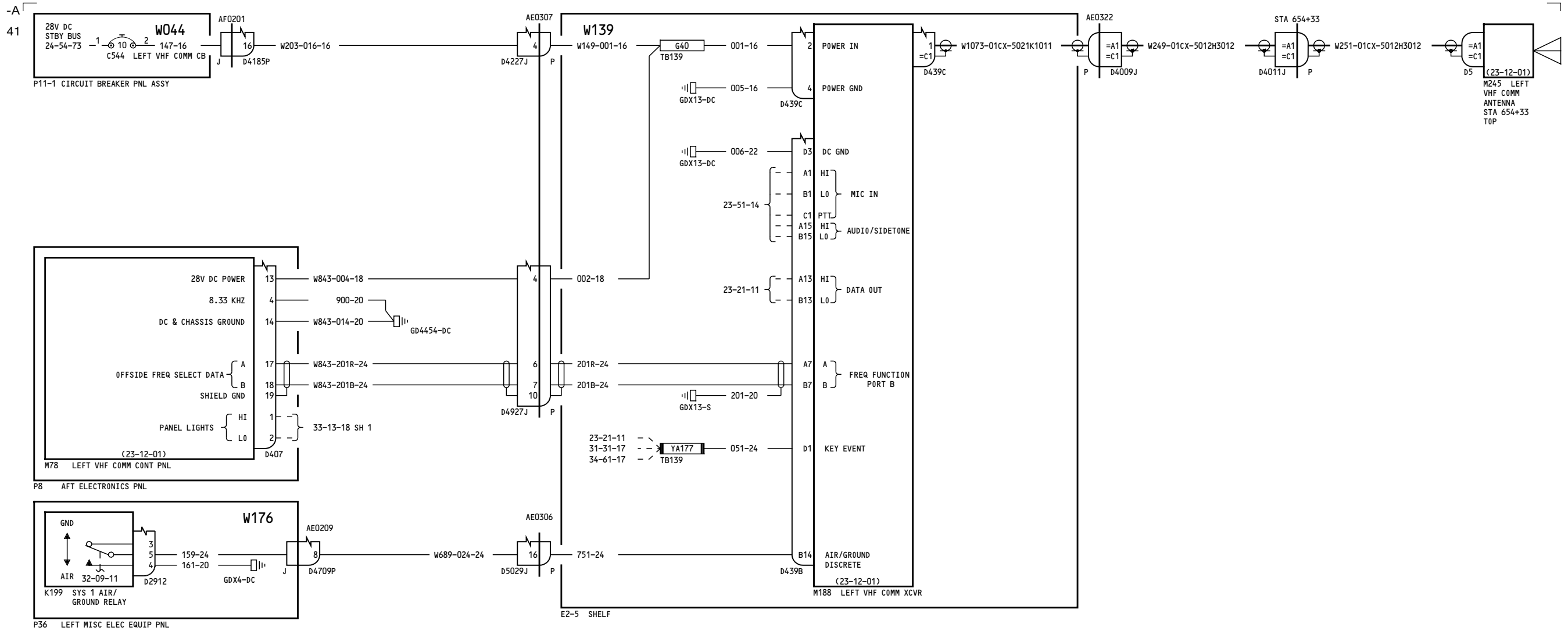

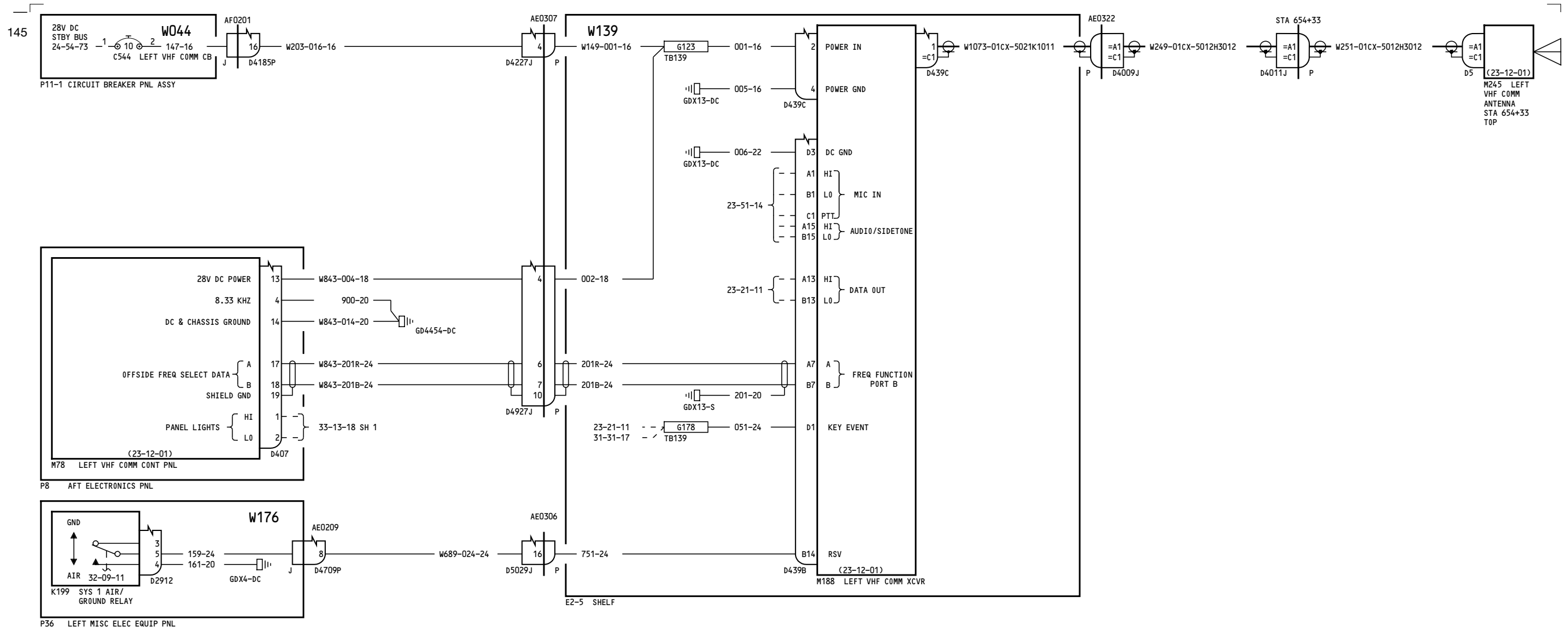

275-276

VHF COMMUNICATION-LEFT

D280T132

23-12-11

Page 7A

Jan 21/2005

Incorporates
MTO-230731

23-12-11

Page 7A

Jan 21/2005

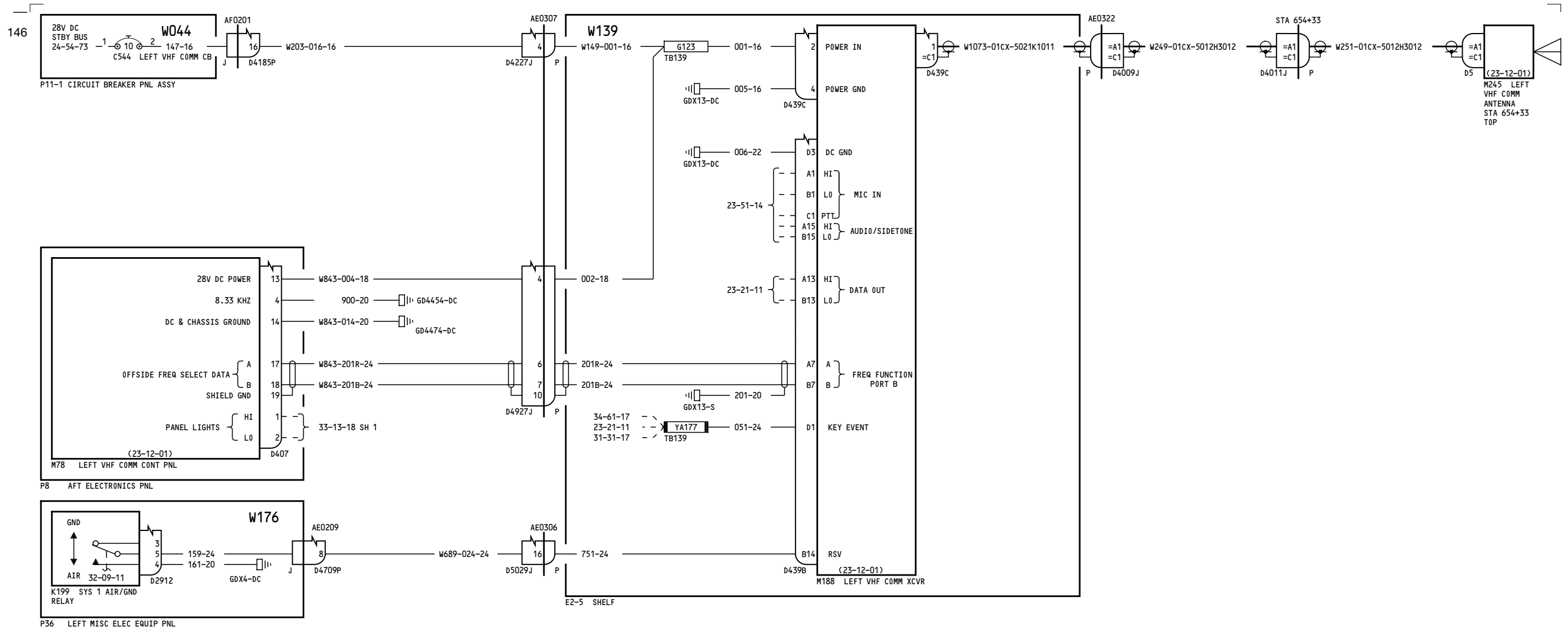

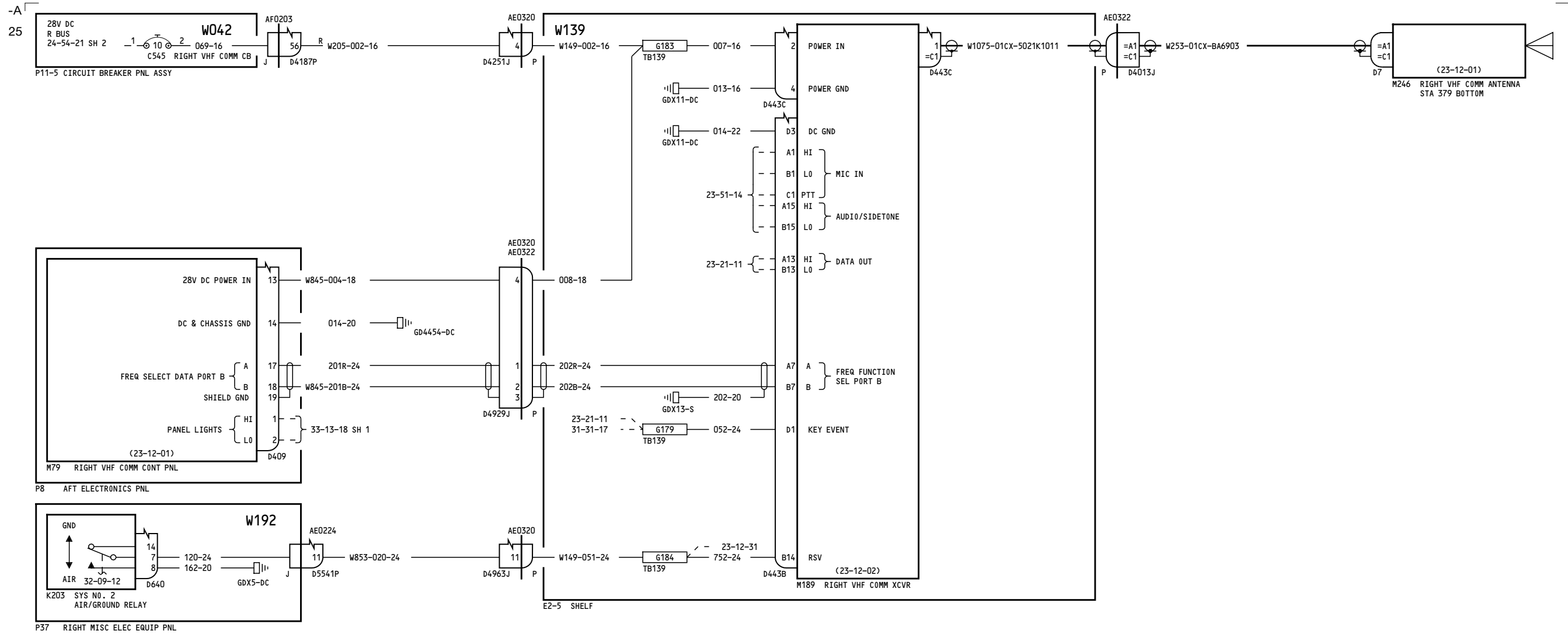

050-099

VHF COMMUNICATION-RIGHT

23-12-21

Page 1

D280T132

Jan 21/2005

23-12-21

Page 1

Jan 21/2005

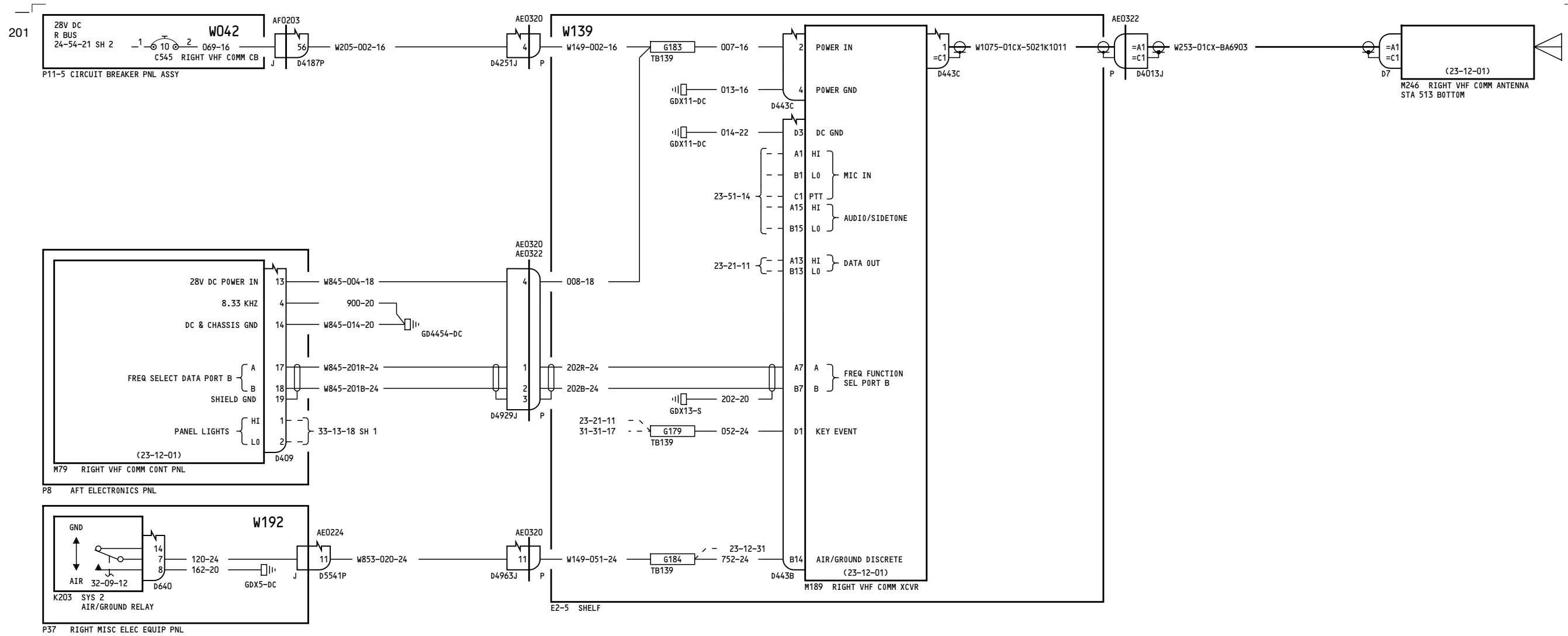

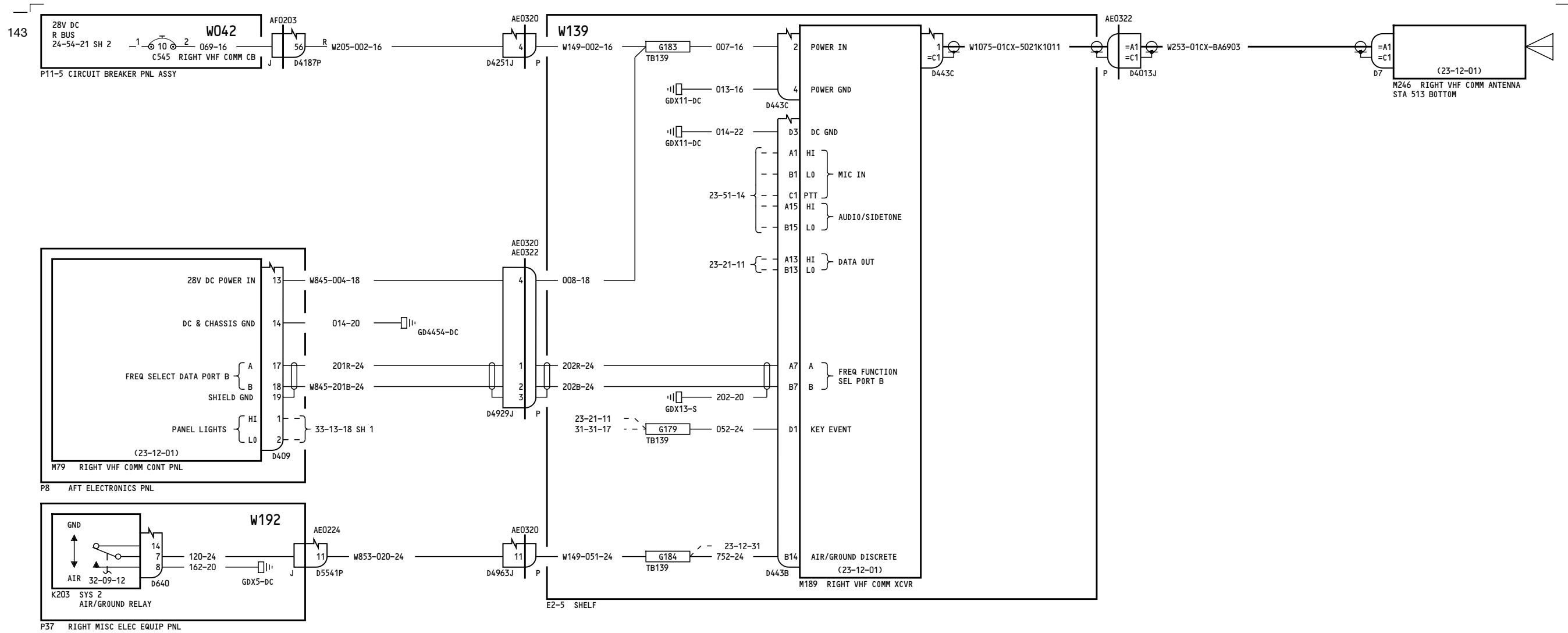

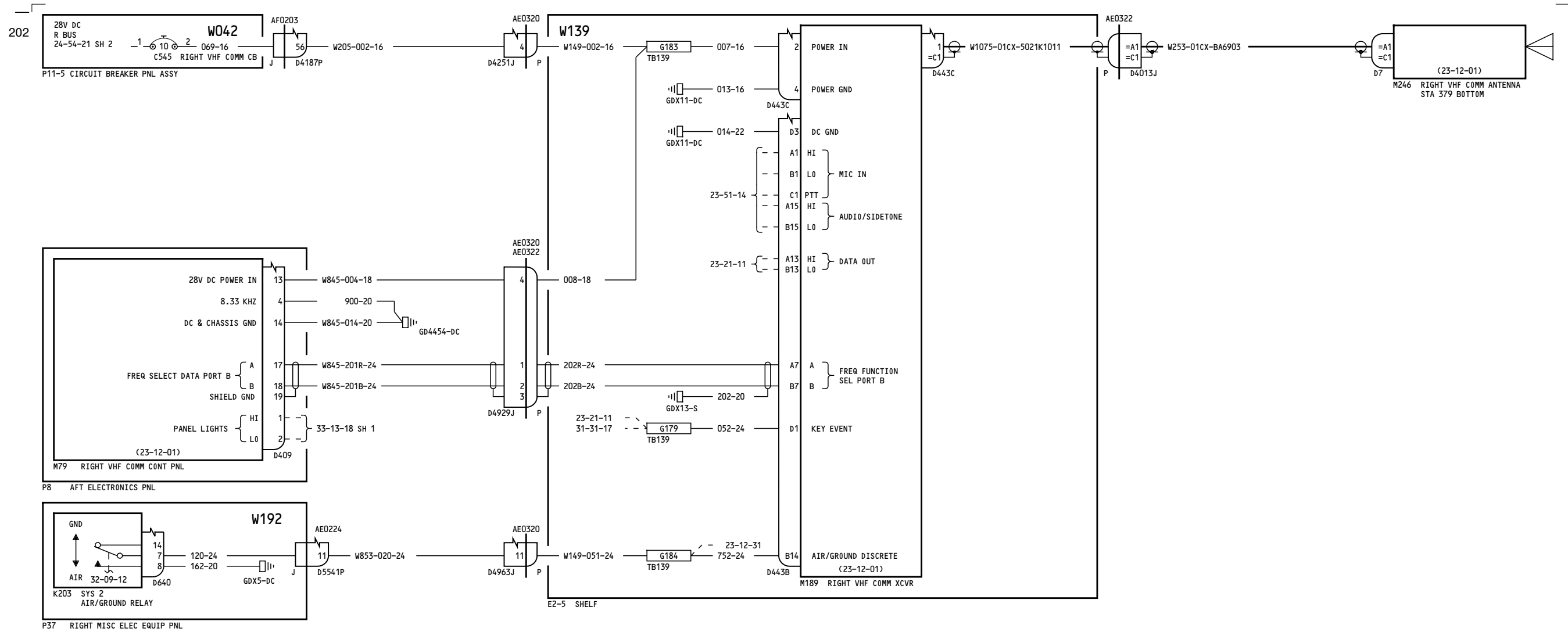

153-156, 162-166

**VHF COMMUNICATION-
RIGHT**

D280T132

23-12-21

Page 4A

Jan 21/2005

Incorporates
MTO-230731

23-12-21

Page 4A

Jan 21/2005

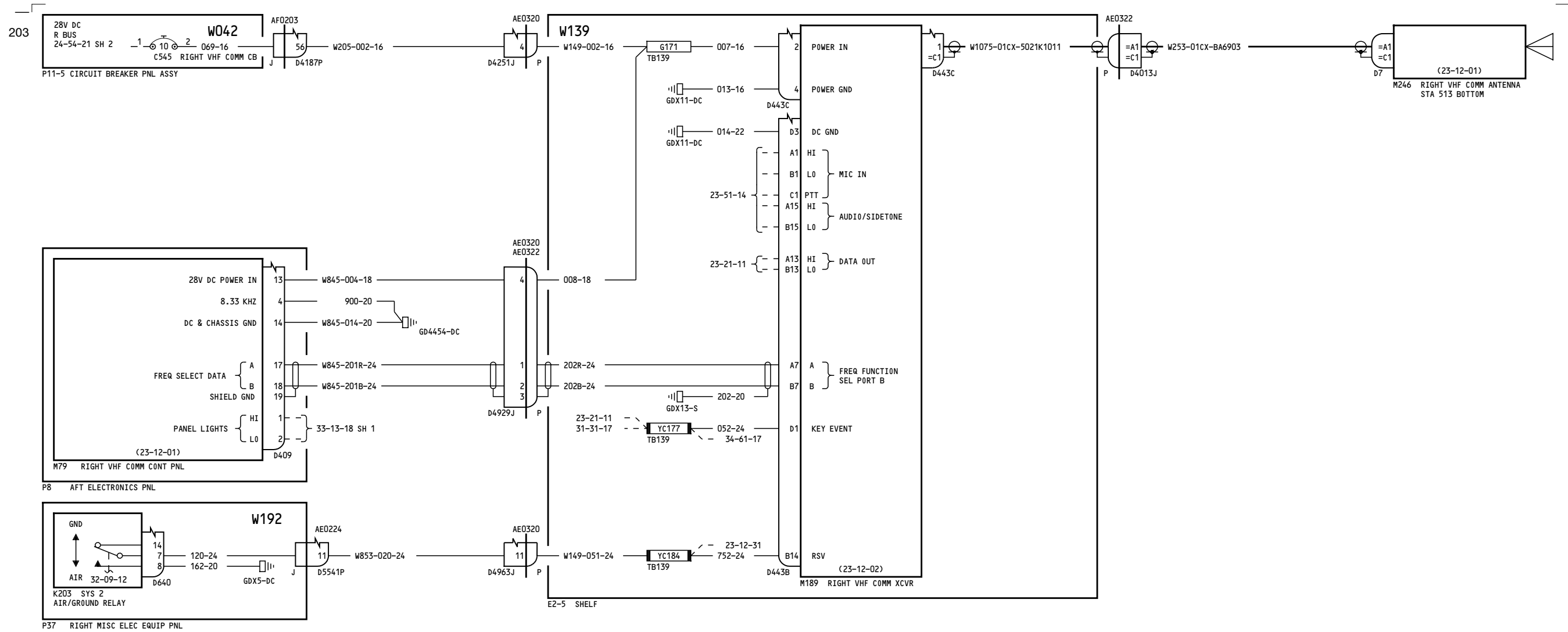

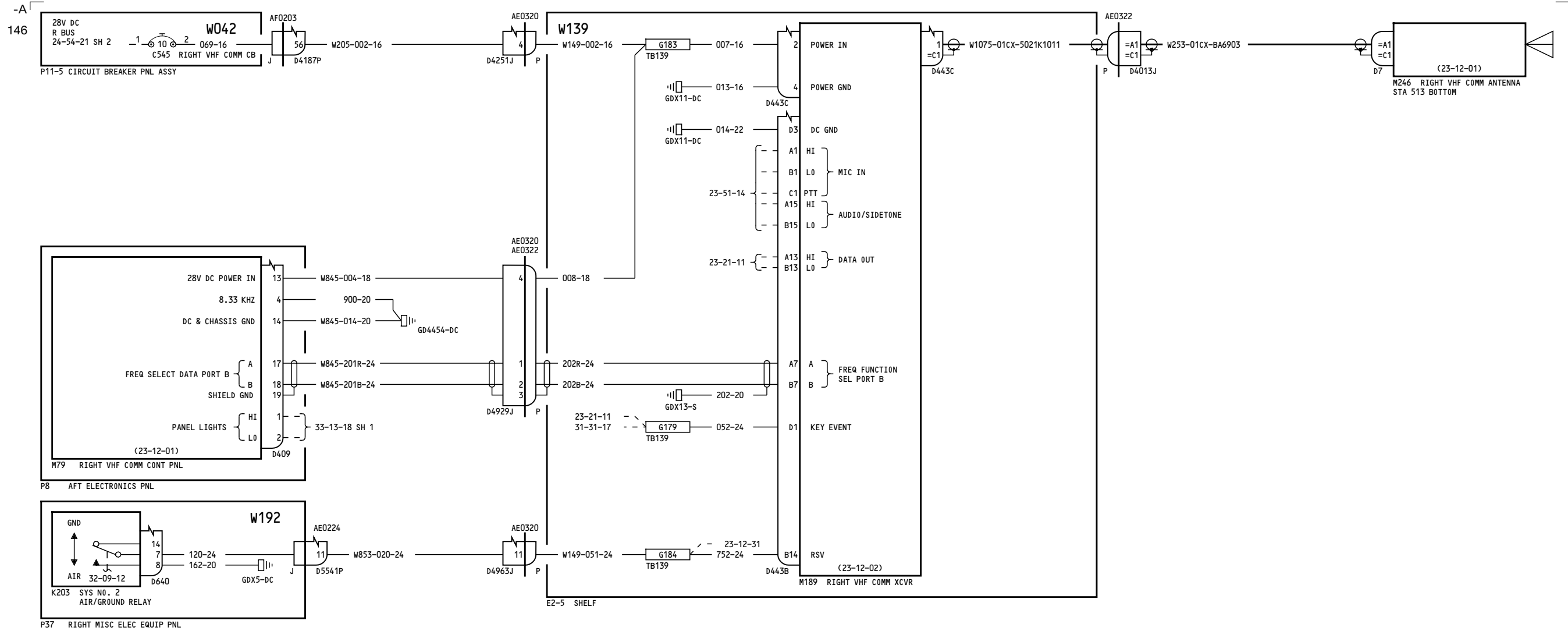

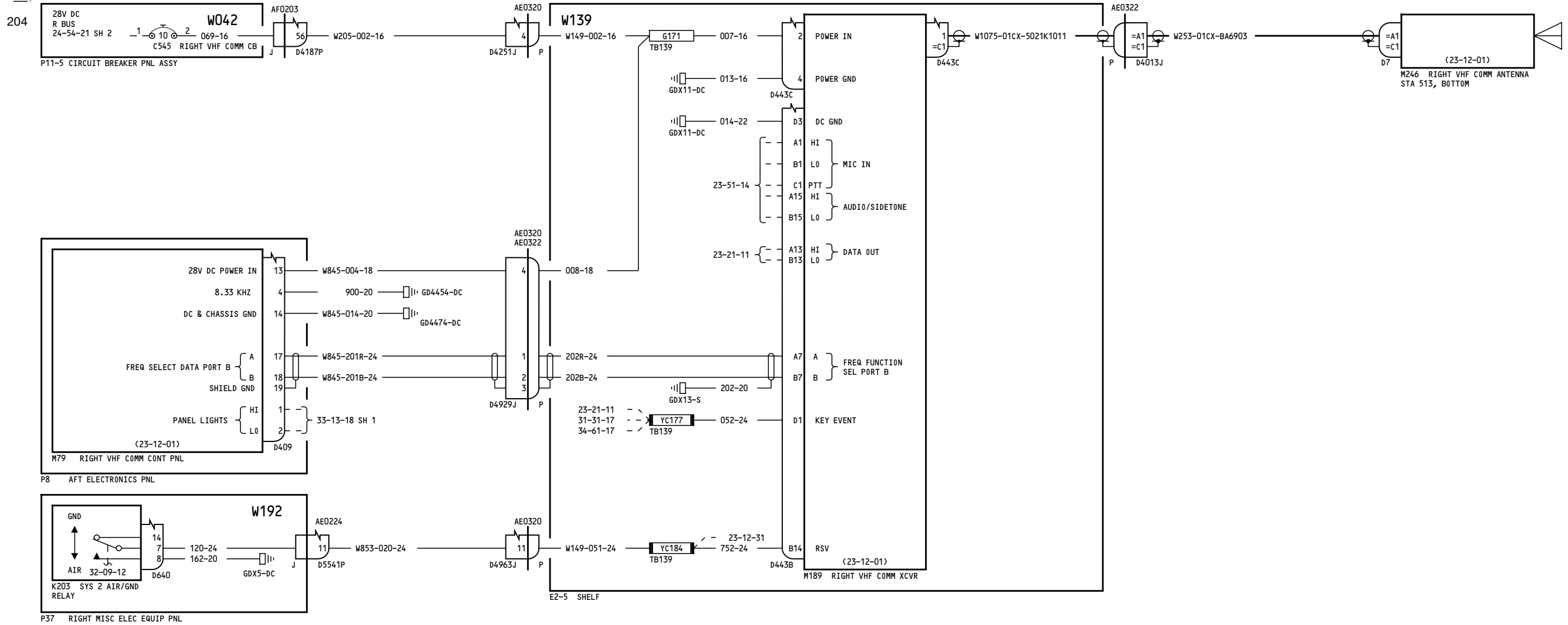

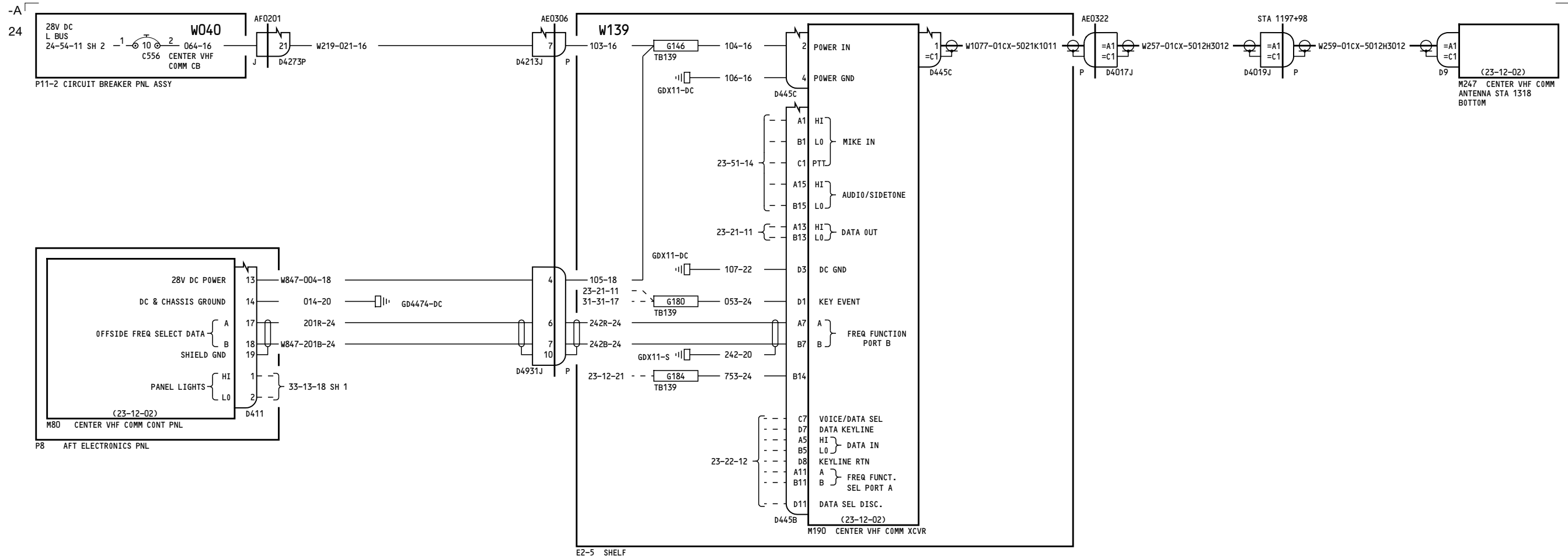

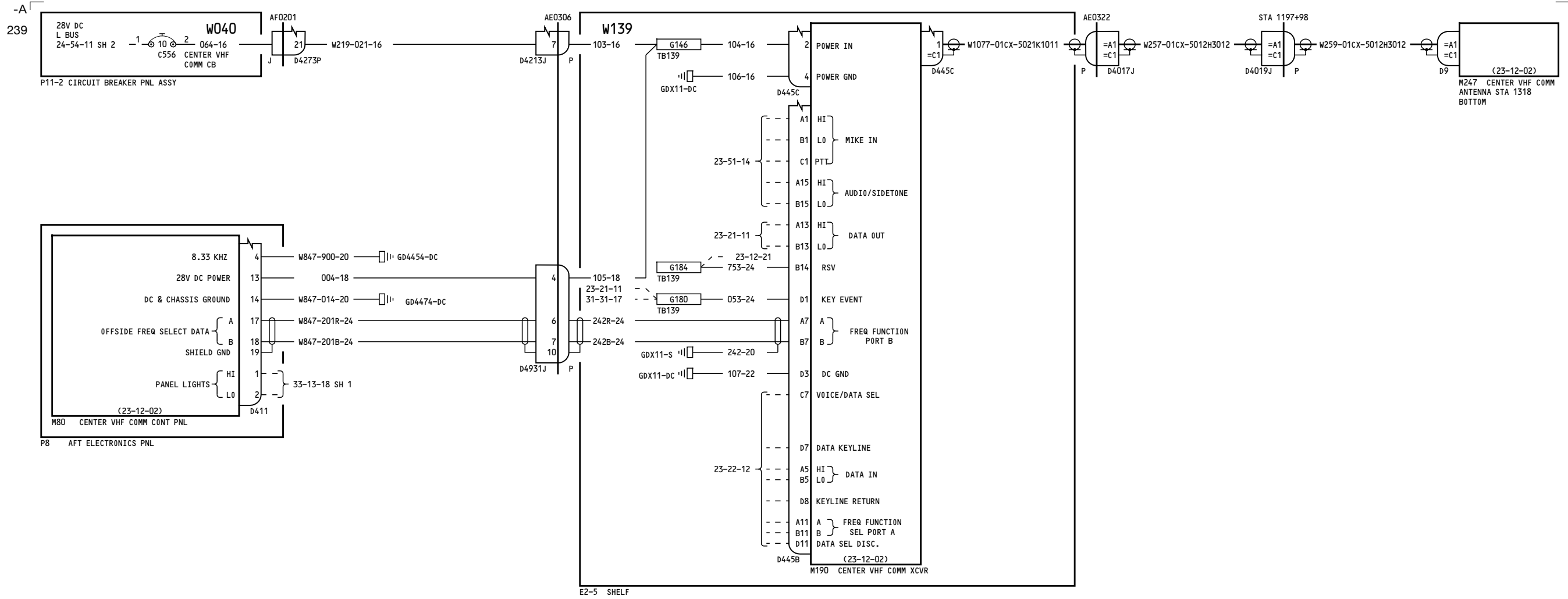

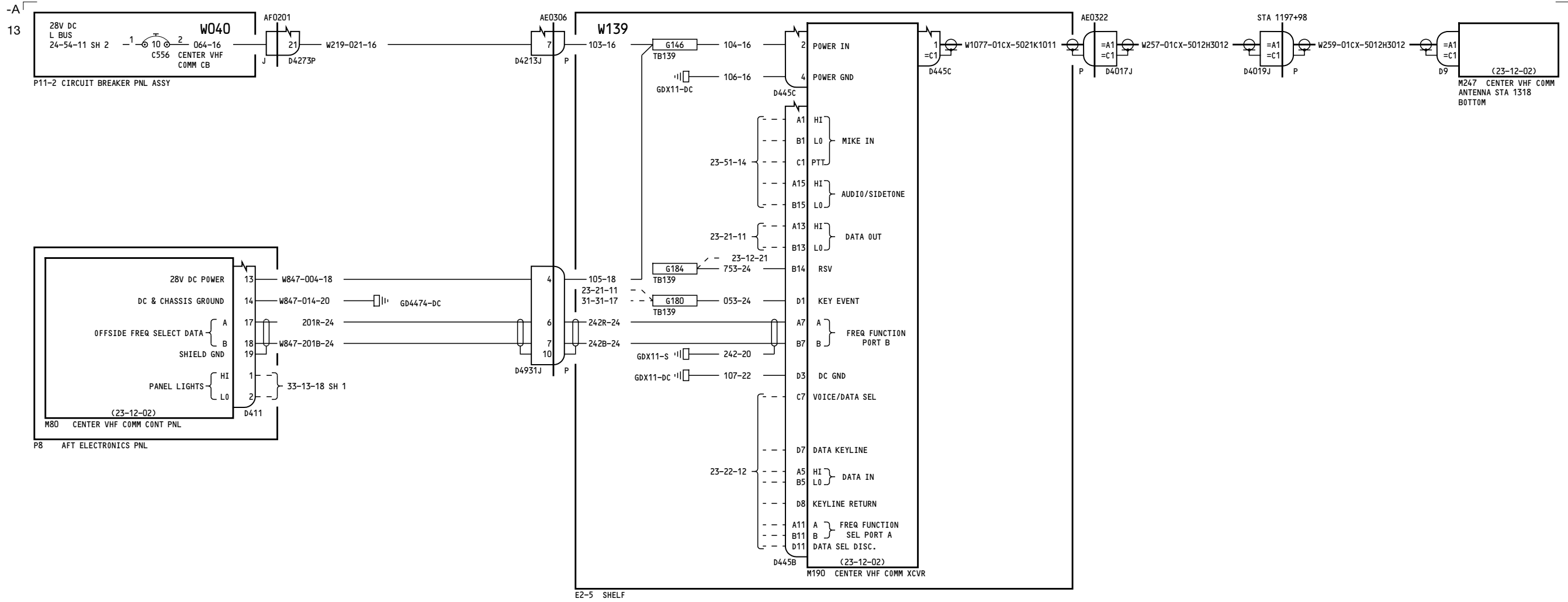

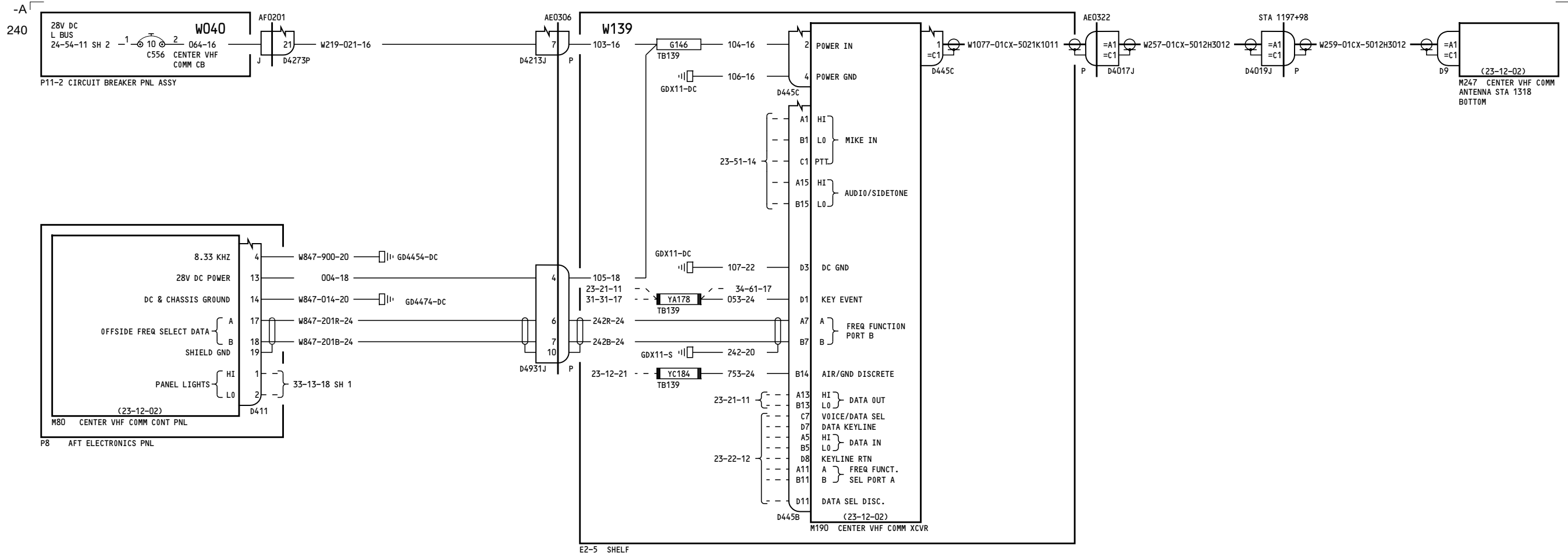

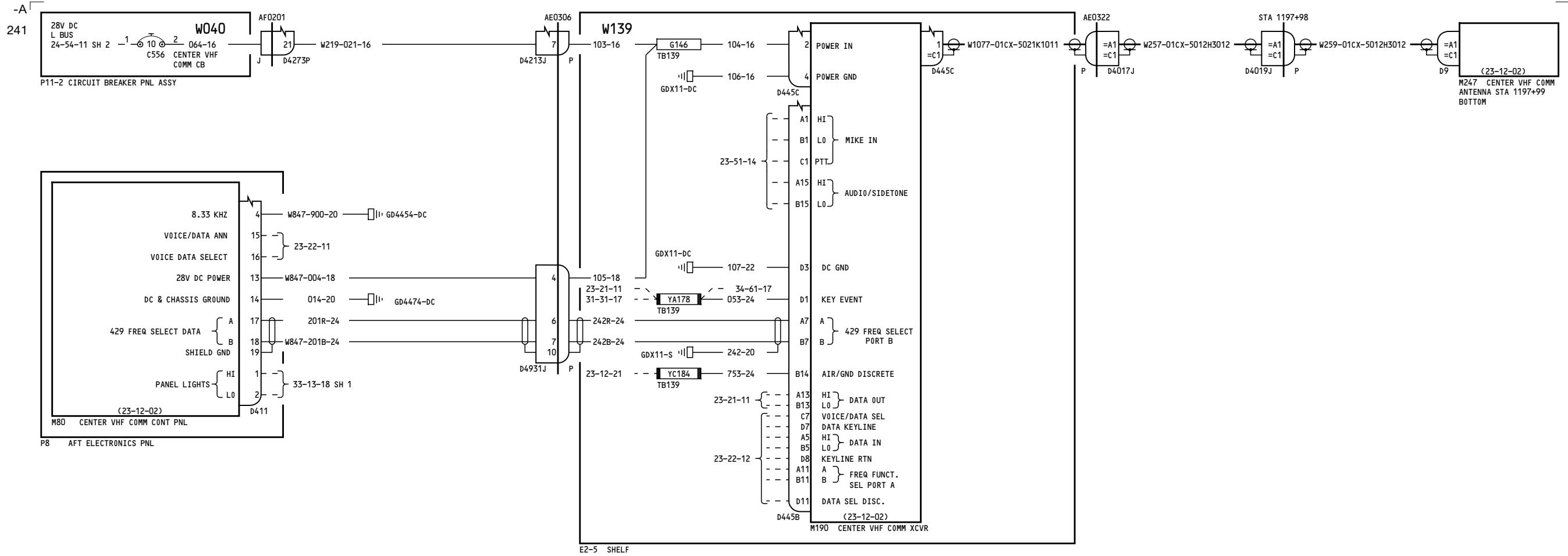

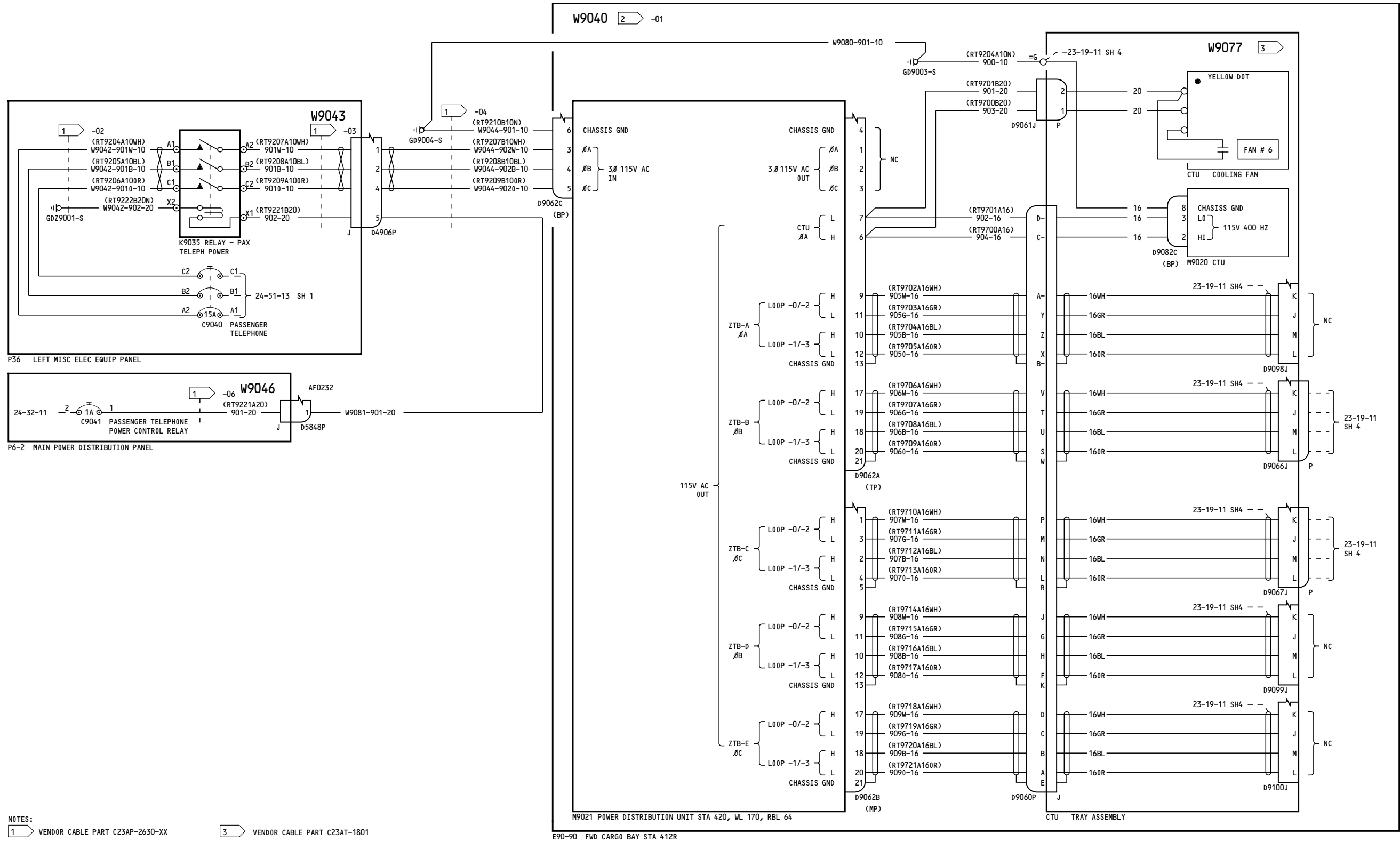

NOTES:
1 VENDOR CABLE PART C23AP-2630-XX
2 VENDOR CABLE PART C23AP-1517-XX

3 VENDOR CABLE PART C23AT-1801

150	AIR-TO-GROUND PUBLIC TELEPHONE
D280T132	

23-19-11

Page 1A
Sheet 1
Jan 21/2005

Incorporates
MTO-230695

23-19-11

Page 1A
Sheet 1
Jan 21/2005

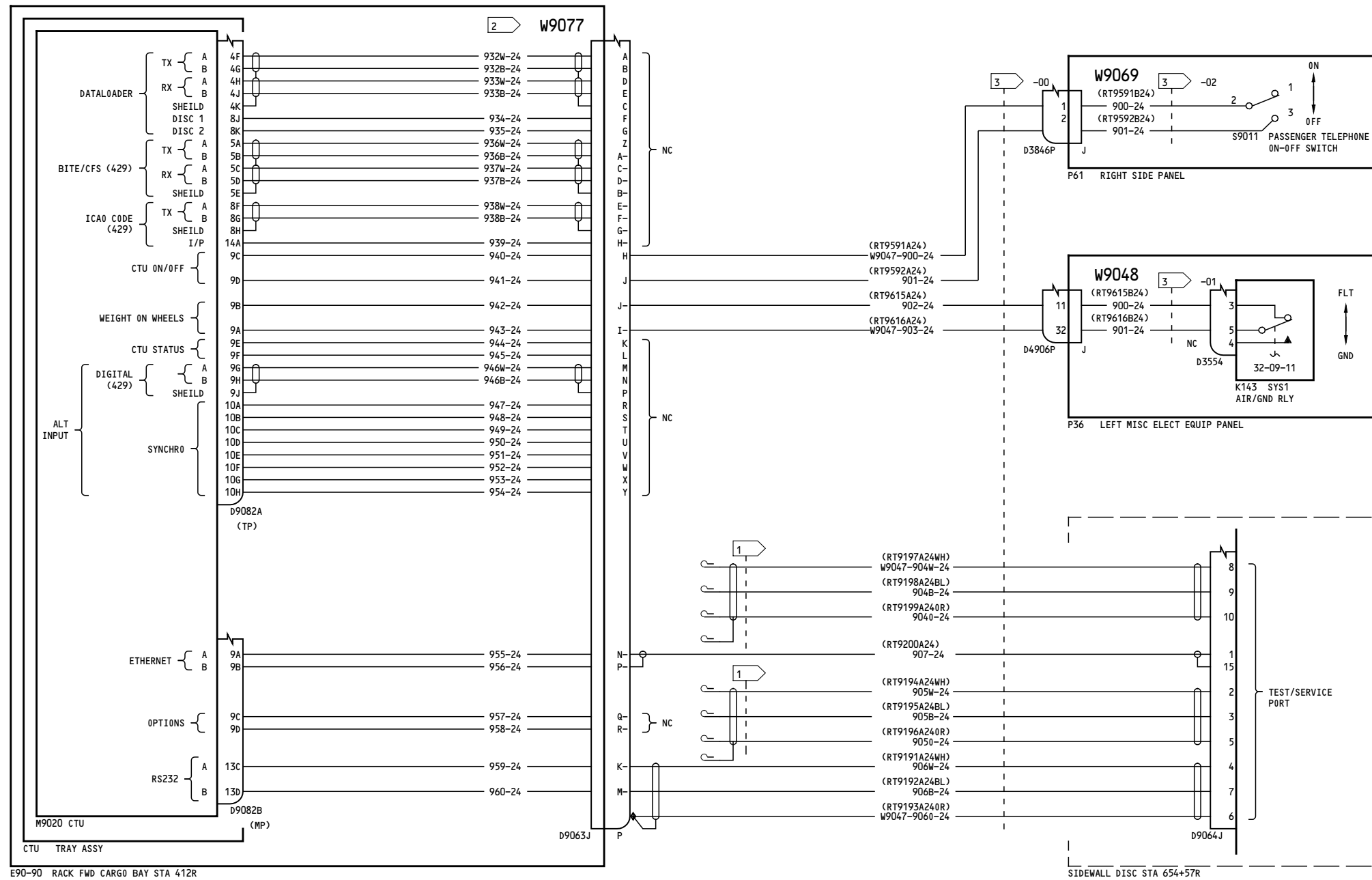

E90-90 RACK FWD CARGO BAY STA 412R

SIDEWALL DISC STA 654+57R

- NOTES :
- 1 CAP & STOW NEAR D9063P
 - 2 VENDOR CABLE PART C23AT-1801
 - 3 VENDOR CABLE PART C23AS-2016-XX

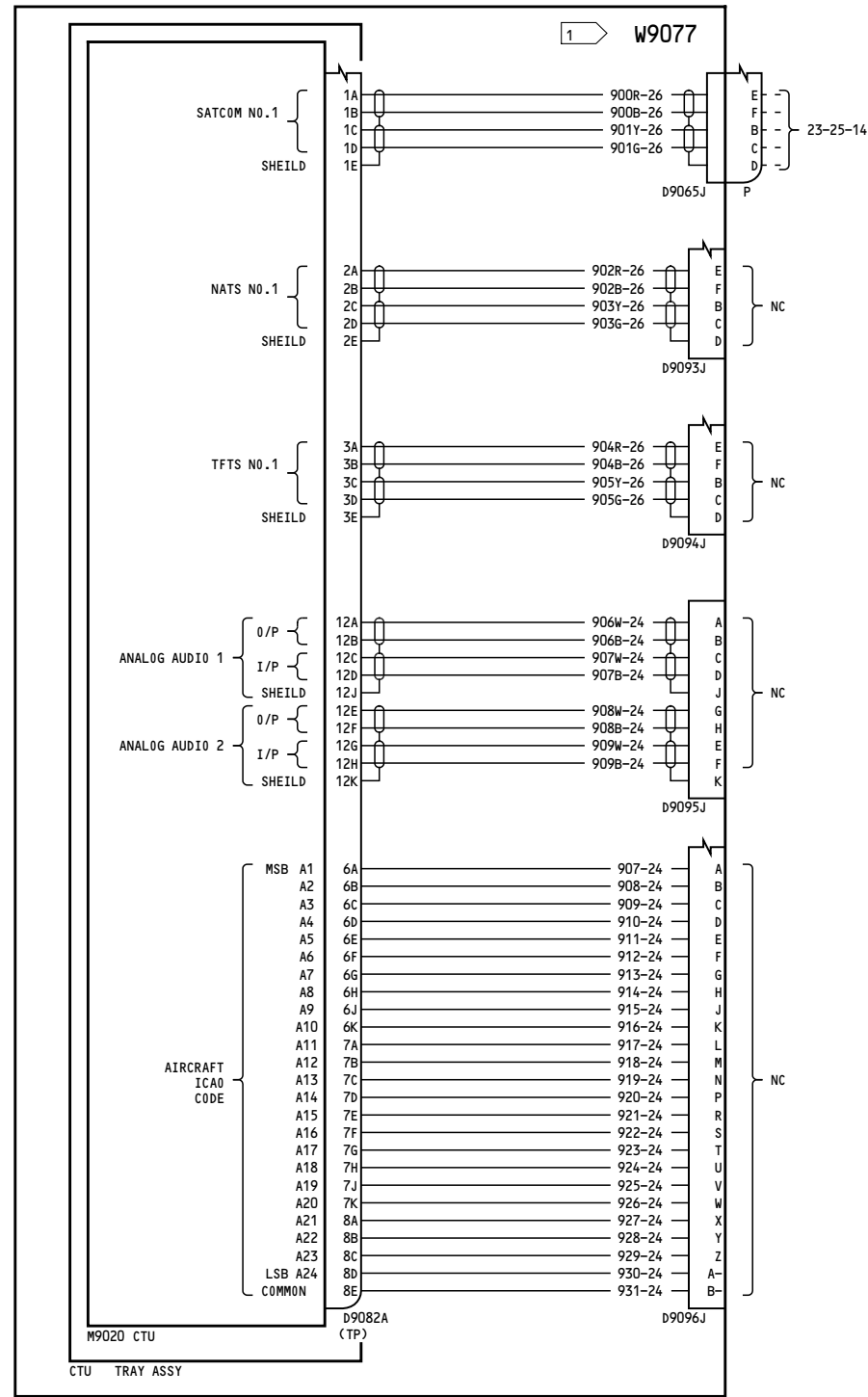

E90-90 RACK FWD CARGO BAY STA 412R

NOTES:
1) VENDOR CABLE PART C23AT-1801

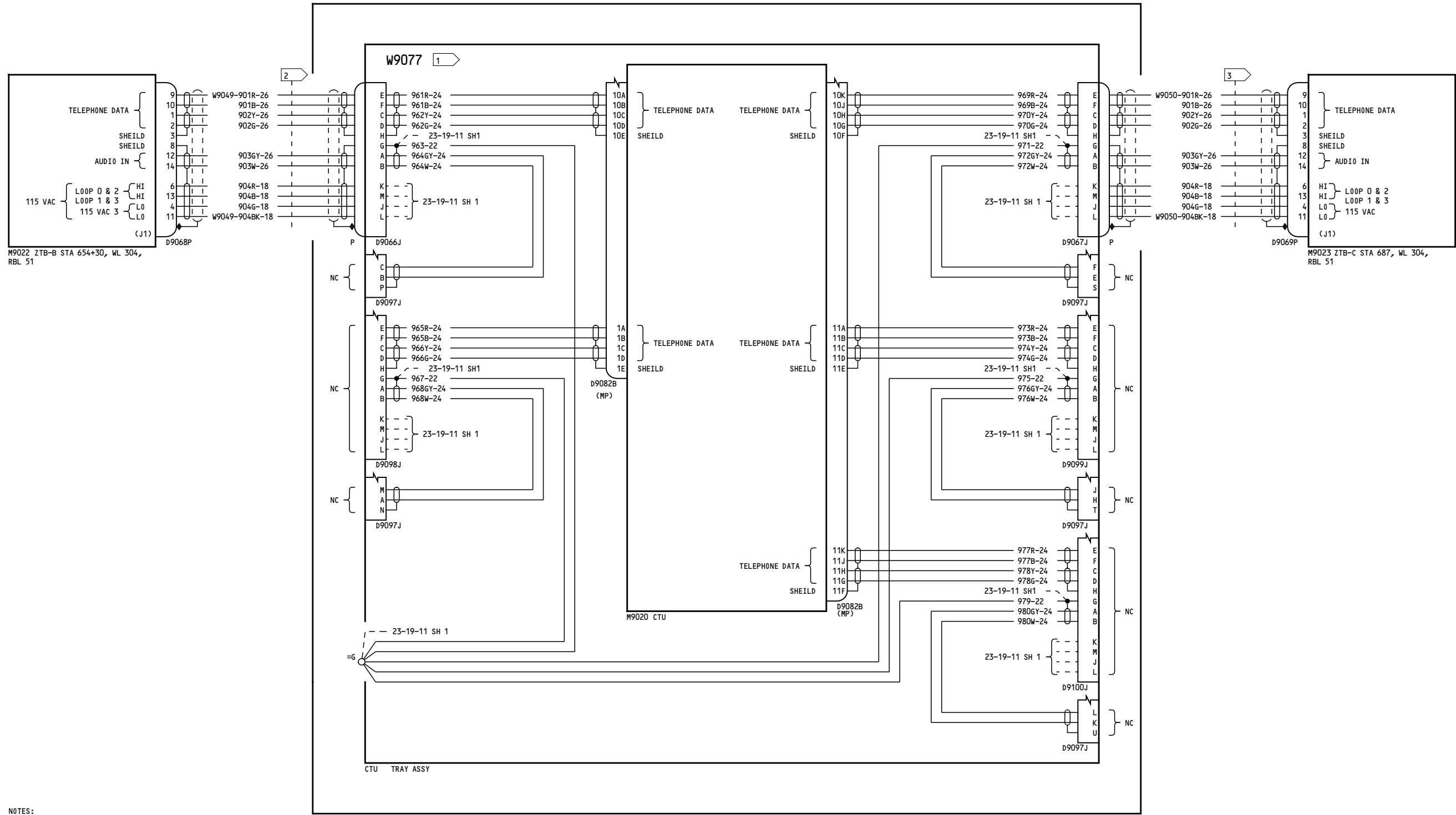

- NOTES:
- 1 VENDOR CABLE PART C23AT-1801
 - 2 VENDOR CABLE PART C23AF-1202-43
 - 3 VENDOR CABLE PART C23AF-1203-57

150

**AIR-TO-GROUND
PUBLIC TELEPHONE**

D280T132

23-19-11

Page 1A
Sheet 4
Jan 21/2005

Incorporates
MTO-230695

23-19-11

Page 1A
Sheet 4
Jan 21/2005

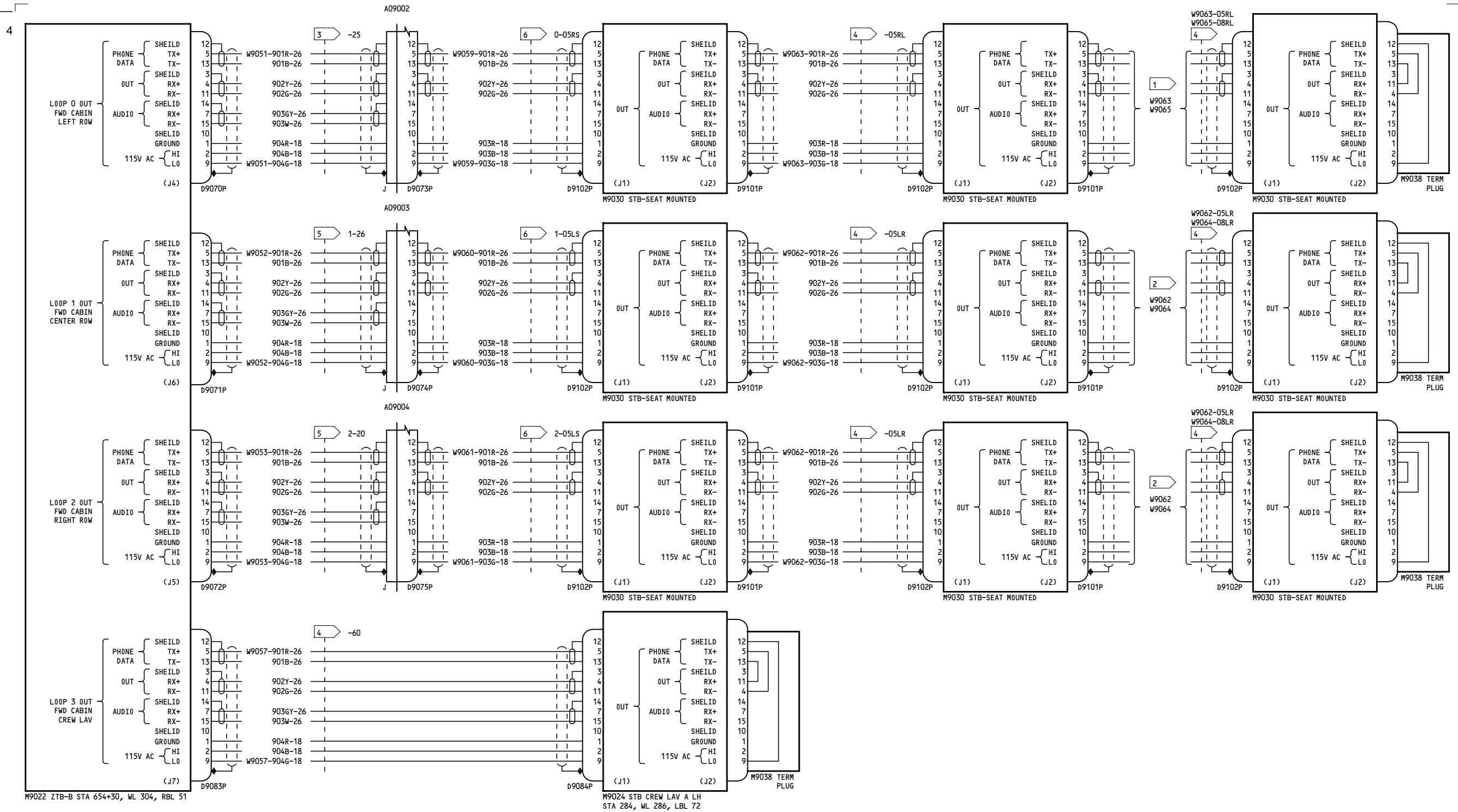

- NOTES:
- 1 W9063 BTW OTHER SEATS IN SAME ROW TO ROW BUNDLE
 - 2 W9062 BTW OTHER SEATS IN SAME ROW
 - 3 W9064 BTW 2ND & 3RD SEAT
 - 4 VENDOR CABLE PART C23CE-3484-XX
 - 5 VENDOR CABLE PART C23CE-343X-XX
 - 6 VENDOR CABLE PART C23CE-346X-XX

**AIR-TO-GROUND
PUBLIC TELEPHONE**

23-19-11

Incorporates
MTO-230695

23-19-11

D280T132

Page 1A
Sheet 5
Jan 21/2005

Page 1A
Sheet 5
Jan 21/2005

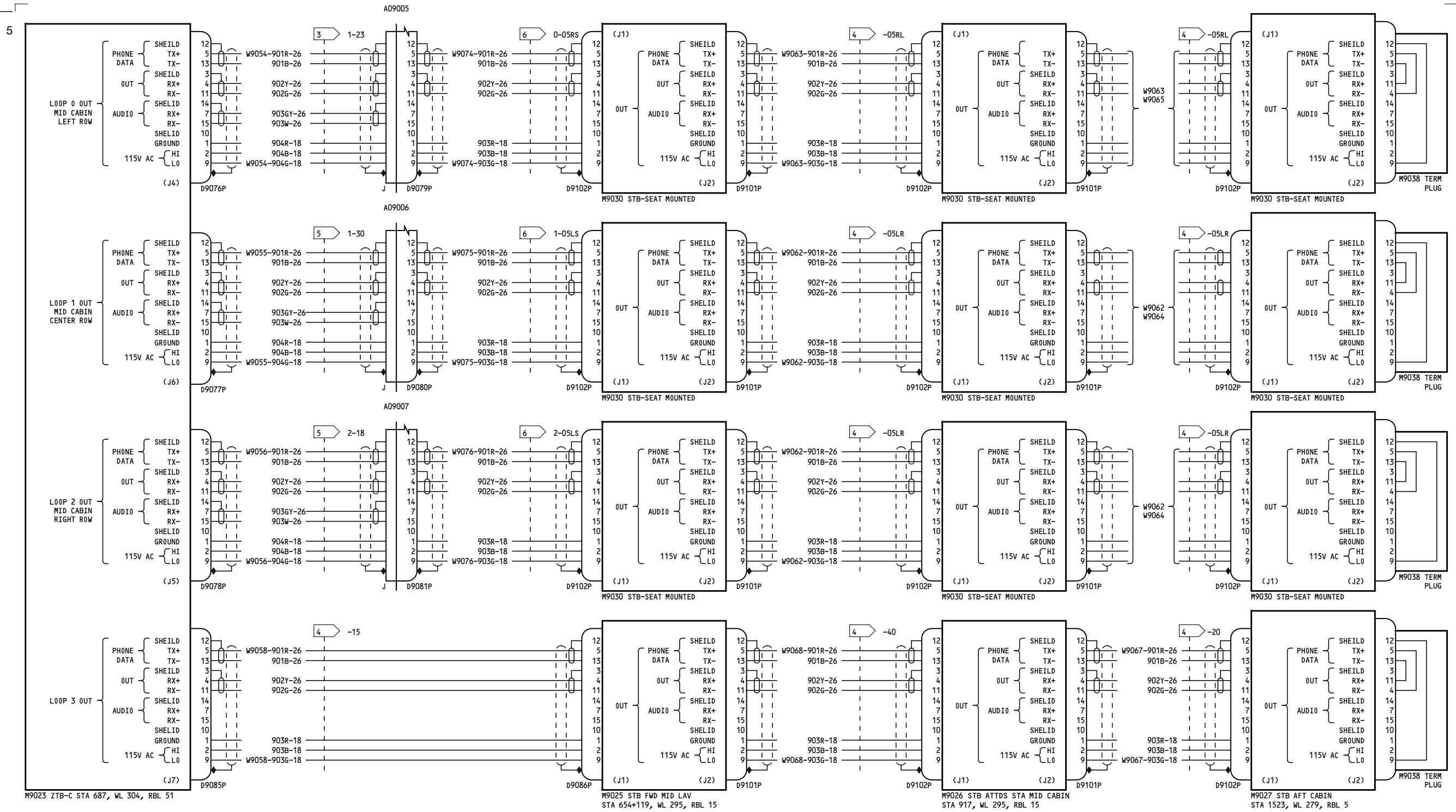

- NOTES:
- 1 W9063 - SEAT TO SEAT BUNDLE
 - 2 W9065 - ROW TO ROW BUNDLE
 - 3 W9062 - SEAT TO SEAT BUNDLE
 - 4 W9064 - ROW TO ROW BUNDLE
 - 5 W9063 - SEAT TO SEAT BUNDLE
 - 6 W9065 - ROW TO ROW BUNDLE
 - 7 W9062 - SEAT TO SEAT BUNDLE
 - 8 W9064 - ROW TO ROW BUNDLE
 - 9 VENDOR CABLE PART C23CE-3484-XX
 - 10 VENDOR CABLE PART C23CE-343X-XX
 - 11 VENDOR CABLE PART C23CE-3430-XX
 - 12 VENDOR CABLE PART C23CE-346X-XX

2

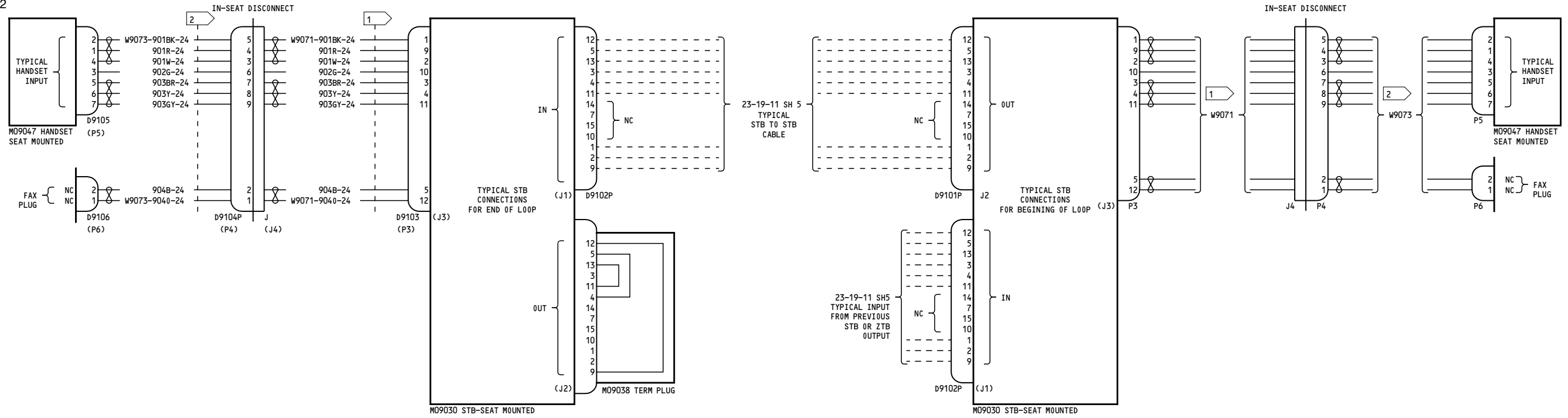

NOTES:
 DIAGRAM REPRESENTS TYPICAL
 STB TO SEAT MOUNTED HANDSET INTERCONNECTION
 1 VENDOR CABLE PART C23PH-6001-04-0
 2 VENDOR CABLE PART C23PH-6004-01-0

150

**AIR-TO-GROUND
 PUBLIC TELEPHONE**

D280T132

23-19-11

Page 1A
 Sheet 7
 Jan 21/2005

Incorporates
 MTO-230695

23-19-11

Page 1A
 Sheet 7
 Jan 21/2005

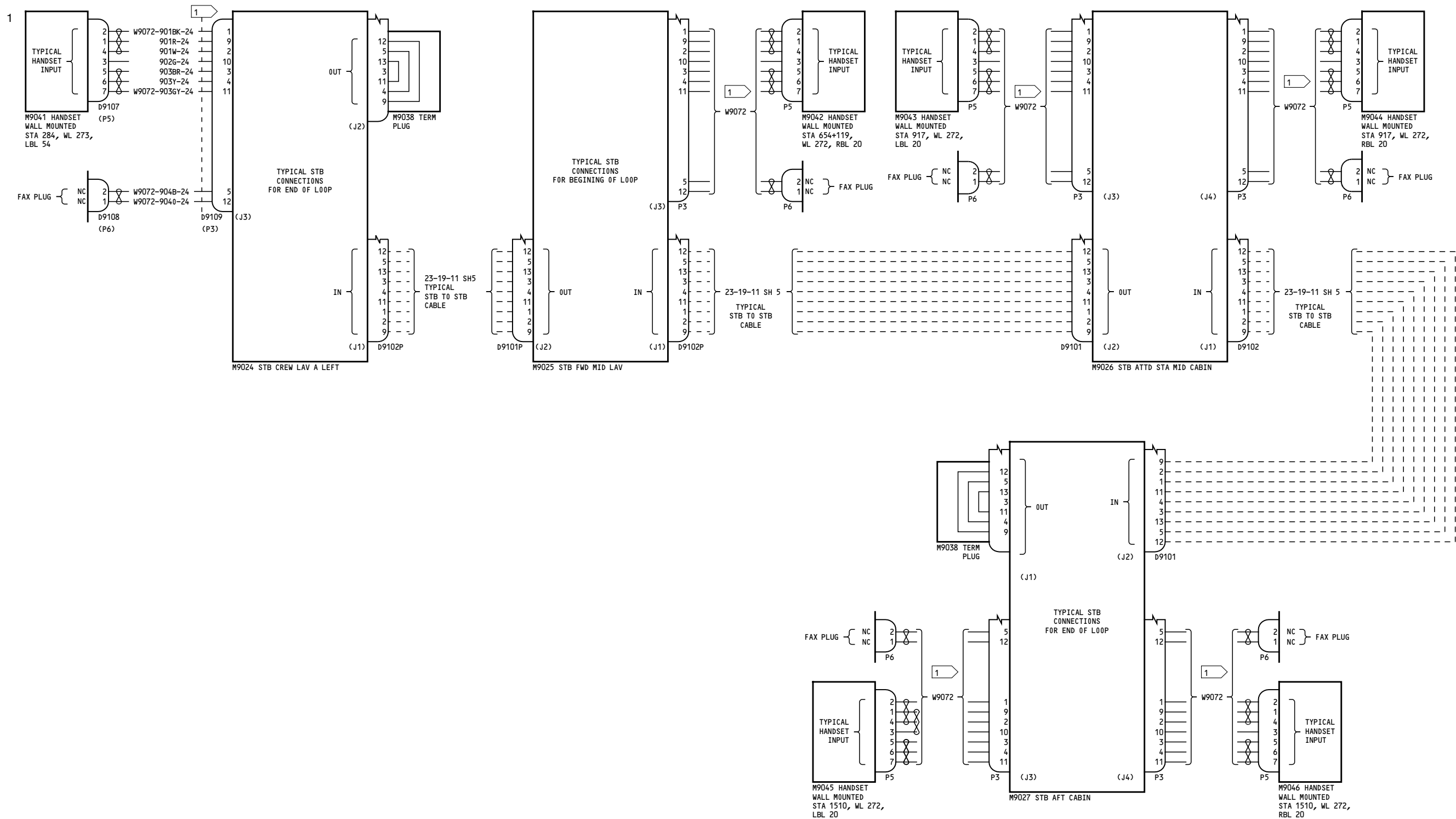

NOTES:
 DIAGRAM REPRESENTS TYPICAL
 STB TO WALL MOUNTED HANDSET INTERCONNECTION

1 VENDOR CABLE PART C23PH-6003-05

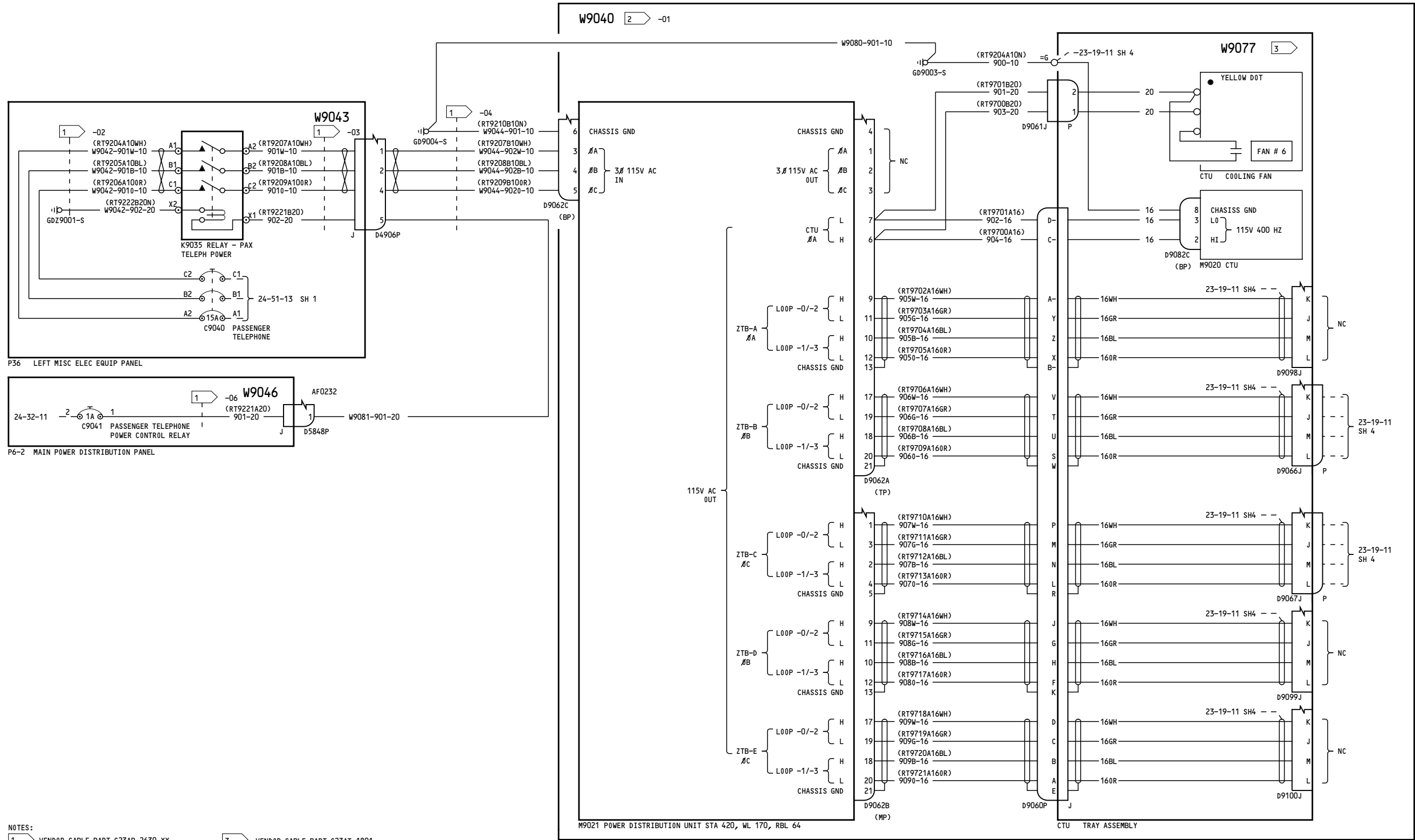

- NOTES:
 1 VENDOR CABLE PART C23AP-2630-XX
 2 VENDOR CABLE PART C23AP-1517-XX

3 VENDOR CABLE PART C23AT-1801

152-167

**AIR-TO-GROUND
PUBLIC TELEPHONE**

D280T132

23-19-11

Page 2A
 Sheet 1
 Jan 21/2005

Incorporates
 MTO-230596

23-19-11

Page 2A
 Sheet 1
 Jan 21/2005

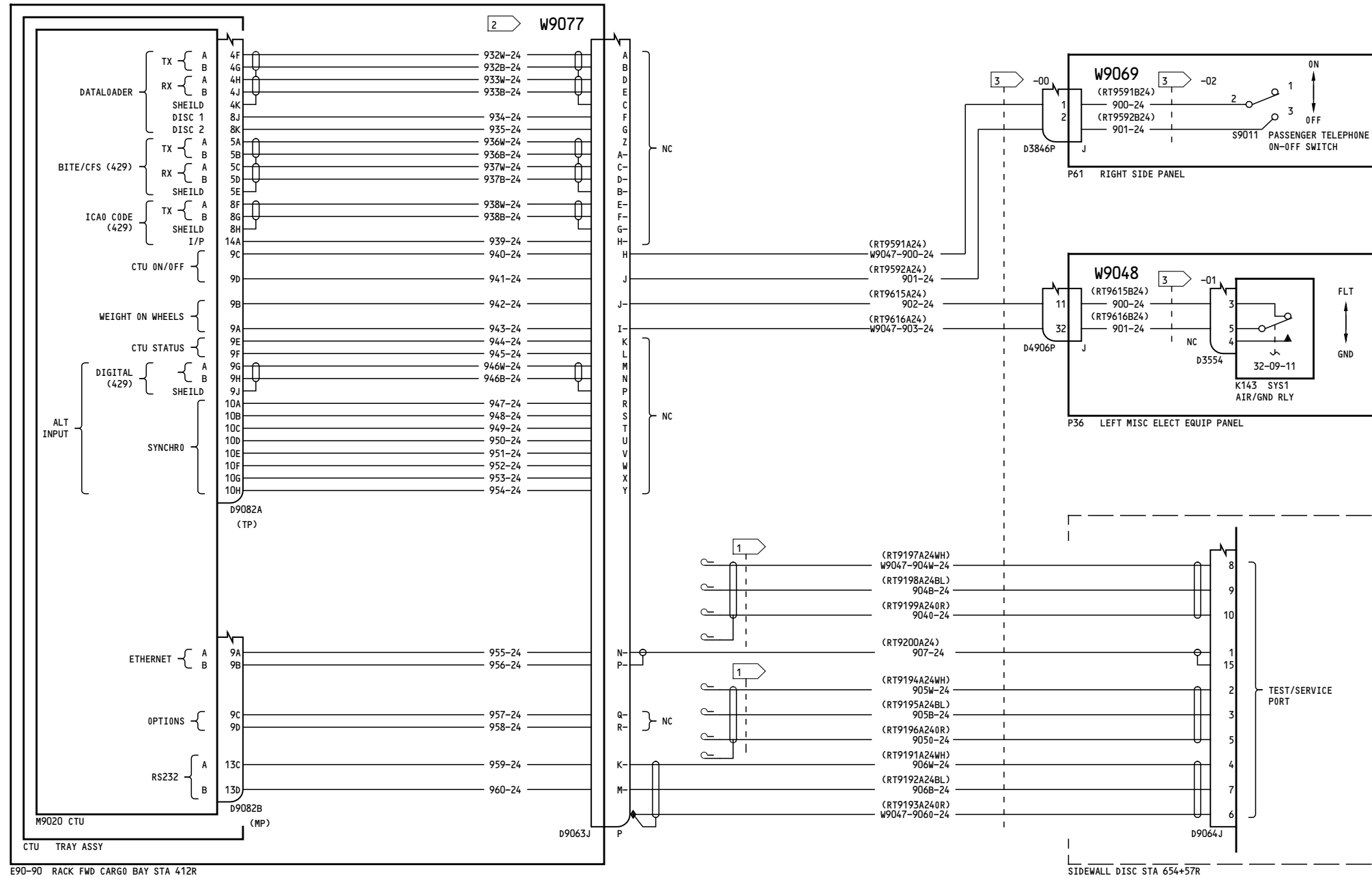

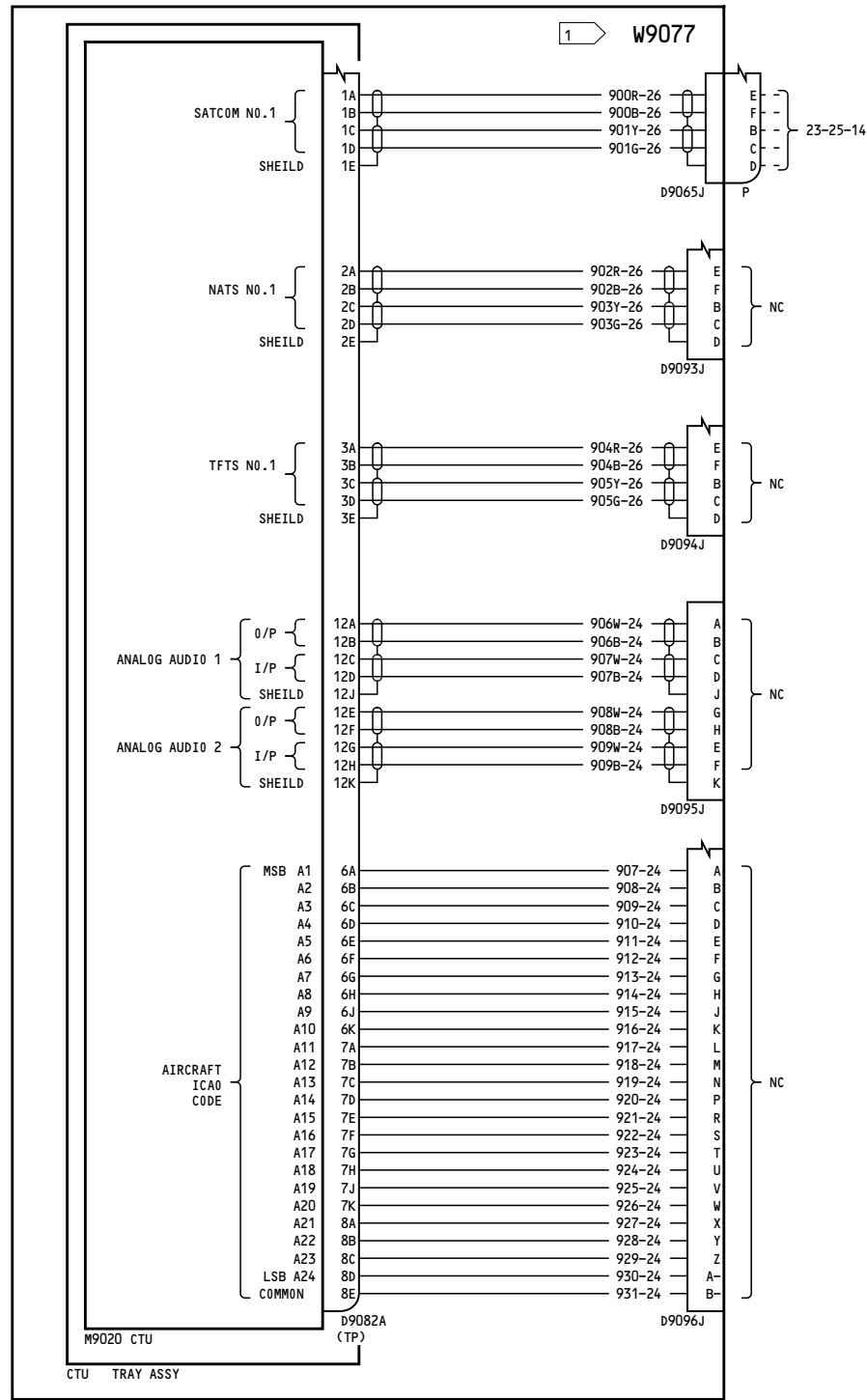

E90-90 RACK FWD CARGO BAY STA 412R

NOTES:
1 VENDOR CABLE PART C23AT-1801

152-167

**AIR-TO-GROUND
PUBLIC TELEPHONE**

D280T132

23-19-11

Page 2A
Sheet 3
Jan 21/2005

Incorporates
MTO-230596

23-19-11

Page 2A
Sheet 3
Jan 21/2005

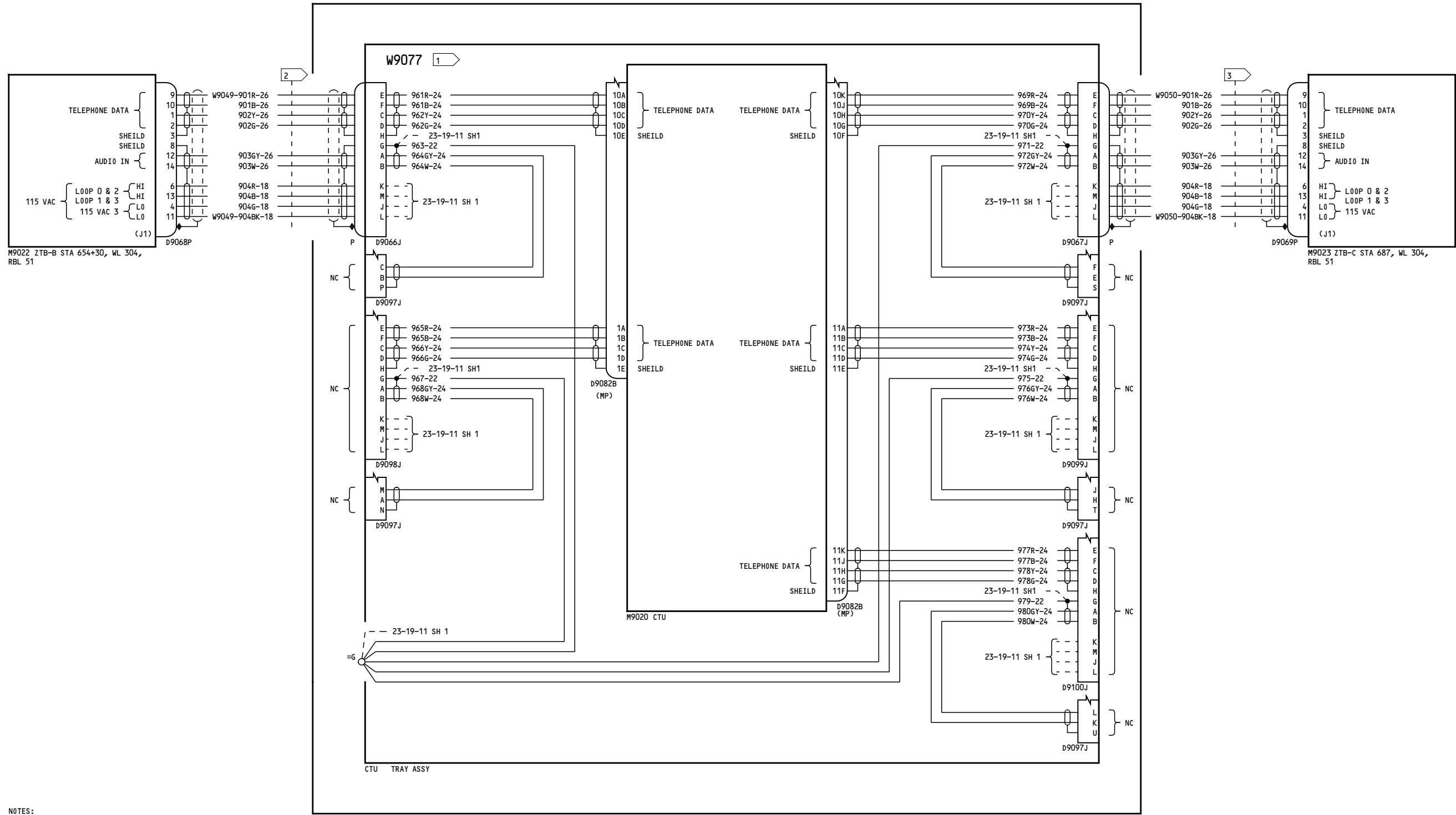

- NOTES:
- 1 VENDOR CABLE PART C23AT-1801
 - 2 VENDOR CABLE PART C23AF-1202-43
 - 3 VENDOR CABLE PART C23AF-1203-57

152-167

**AIR-TO-GROUND
PUBLIC TELEPHONE**

D280T132

23-19-11

Page 2A
Sheet 4
Jan 21/2005

Incorporates
MTO-230596

23-19-11

Page 2A
Sheet 4
Jan 21/2005

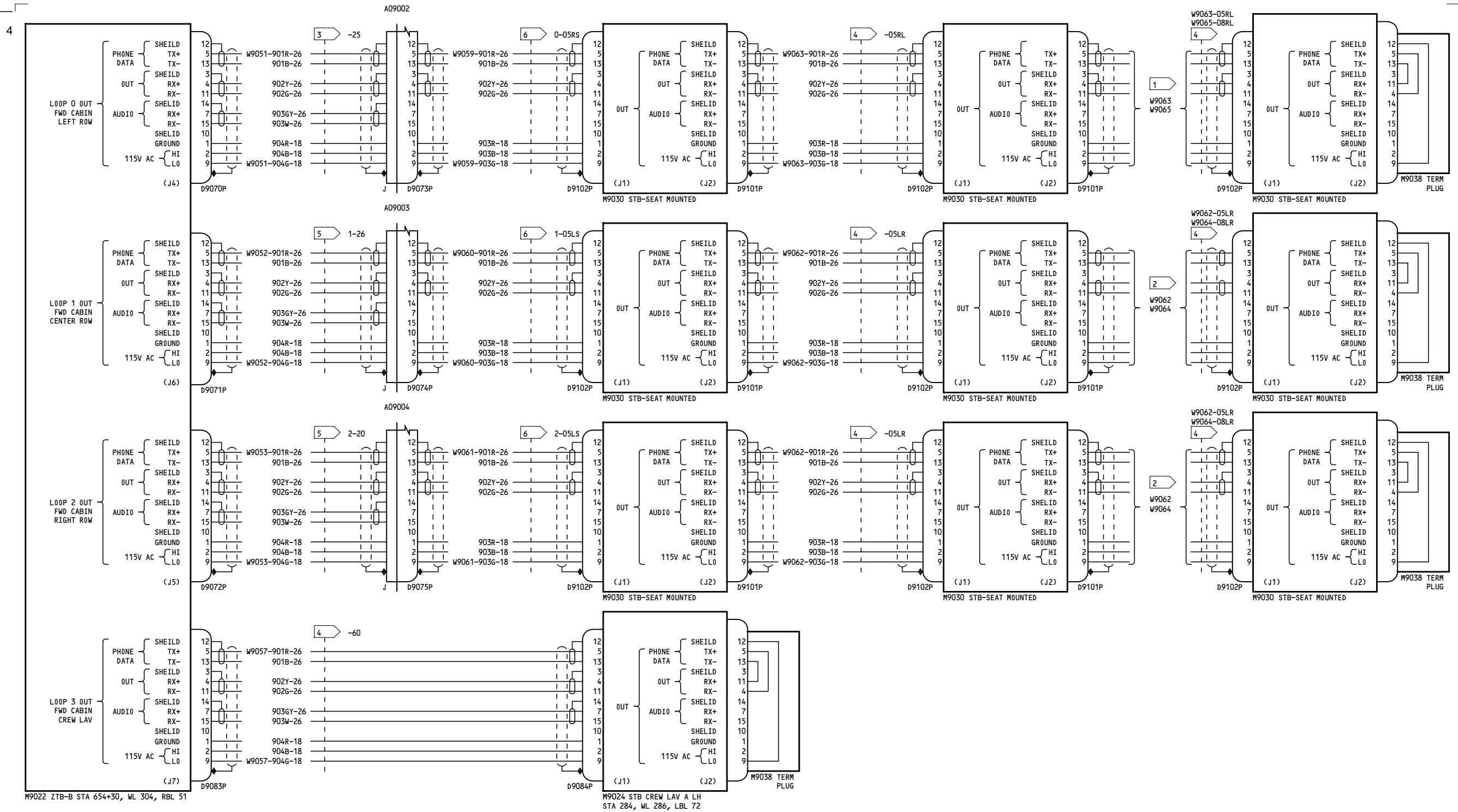

- NOTES:
- 1 W9063 BTW OTHER SEATS IN SAME ROW TO ROW BUNDLE
 - 2 W9062 BTW OTHER SEATS IN SAME ROW
 - 3 W9064 BTW 2ND & 3RD SEAT
 - 4 VENDOR CABLE PART C23CE-3484-XX
 - 5 VENDOR CABLE PART C23CE-343X-XX
 - 6 VENDOR CABLE PART C23CE-346X-XX

152-167

**AIR-TO-GROUND
PUBLIC TELEPHONE**

D280T132

23-19-11

Page 2A
Sheet 5
Jan 21/2005

Incorporates
MTO-230596

23-19-11

Page 2A
Sheet 5
Jan 21/2005

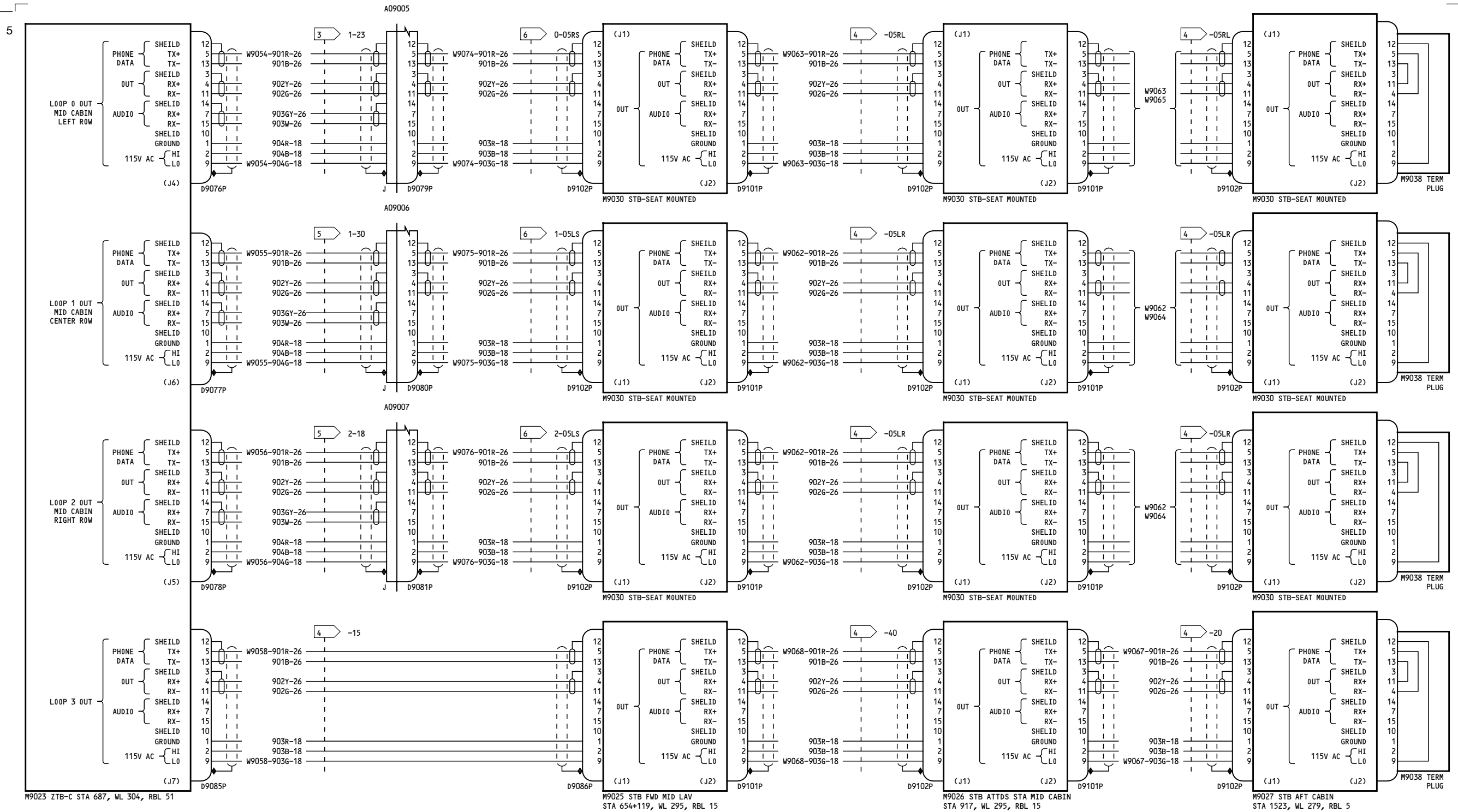

- NOTES:
- 1 W9063 - SEAT TO SEAT BUNDLE
 - 2 W9062 - SEAT TO SEAT BUNDLE
 - 3 W9064 - ROW TO ROW BUNDLE
 - 4 VENDOR CABLE PART C23CE-3484-XX
 - 5 VENDOR CABLE PART C23CE-343X-XX
 - 6 VENDOR CABLE PART C23CE-346X-XX

152-167

**AIR-TO-GROUND
PUBLIC TELEPHONE**

D280T132

23-19-11

Page 2A
Sheet 6
Jan 21/2005

Incorporates
MTO-230596

23-19-11

Page 2A
Sheet 6
Jan 21/2005

2

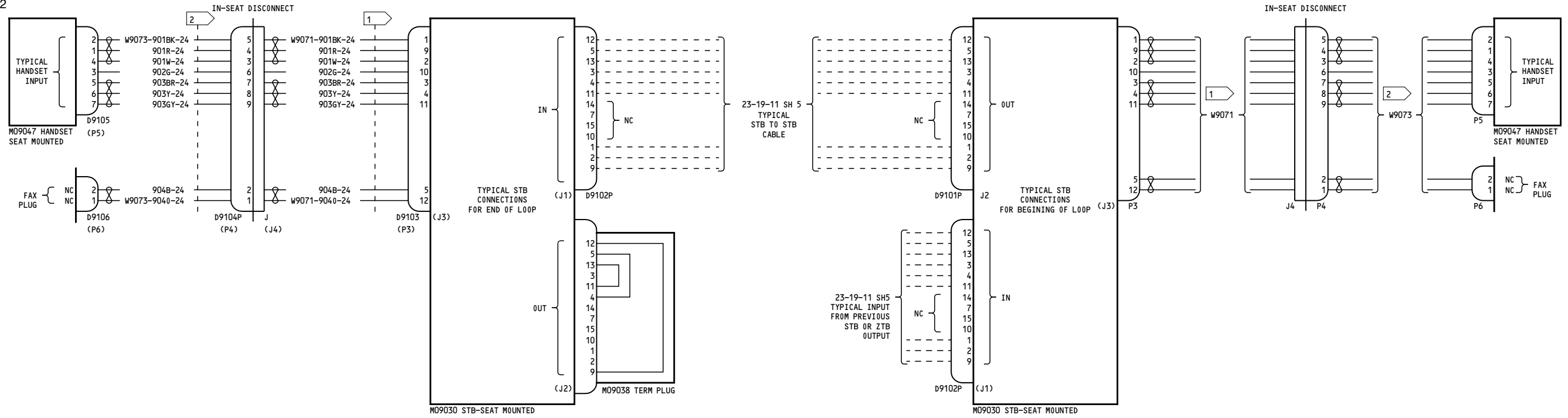

NOTES:
 DIAGRAM REPRESENTS TYPICAL
 STB TO SEAT MOUNTED HANDSET INTERCONNECTION
 1 VENDOR CABLE PART C23PH-6001-04-0
 2 VENDOR CABLE PART C23PH-6004-01-0

152-167

**AIR-TO-GROUND
 PUBLIC TELEPHONE**

D280T132

23-19-11

Page 2A
 Sheet 7
 Jan 21/2005

Incorporates
 MTO-230596

23-19-11

Page 2A
 Sheet 7
 Jan 21/2005

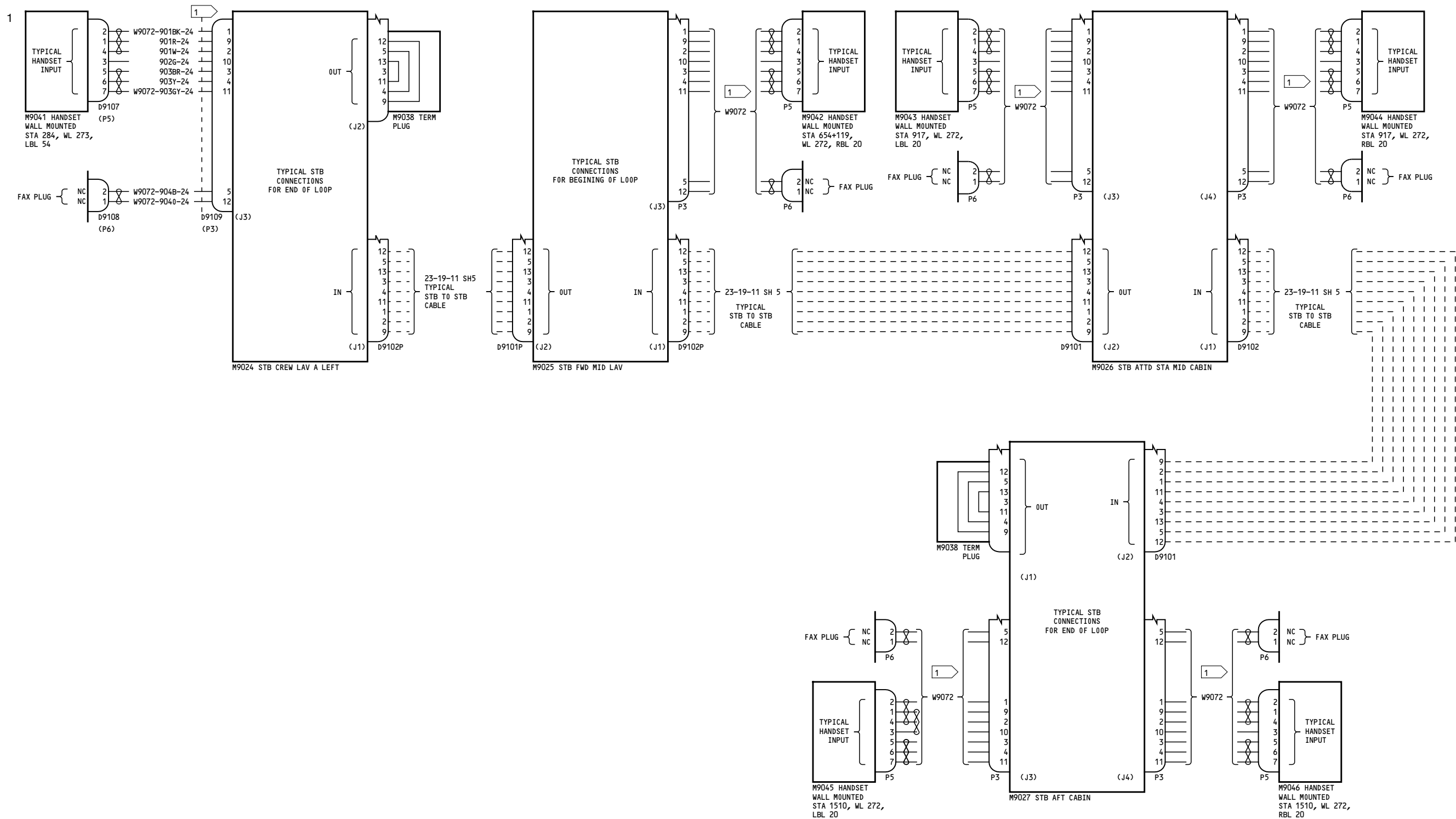

NOTES:
 DIAGRAM REPRESENTS TYPICAL
 STB TO WALL MOUNTED HANDSET INTERCONNECTION

1 VENDOR CABLE PART C23PH-6003-05

152-167

**AIR-TO-GROUND
 PUBLIC TELEPHONE**

D280T132

23-19-11

Page 2A
 Sheet 8
 Jan 21/2005

Incorporates
 MTO-230596

23-19-11

Page 2A
 Sheet 8
 Jan 21/2005

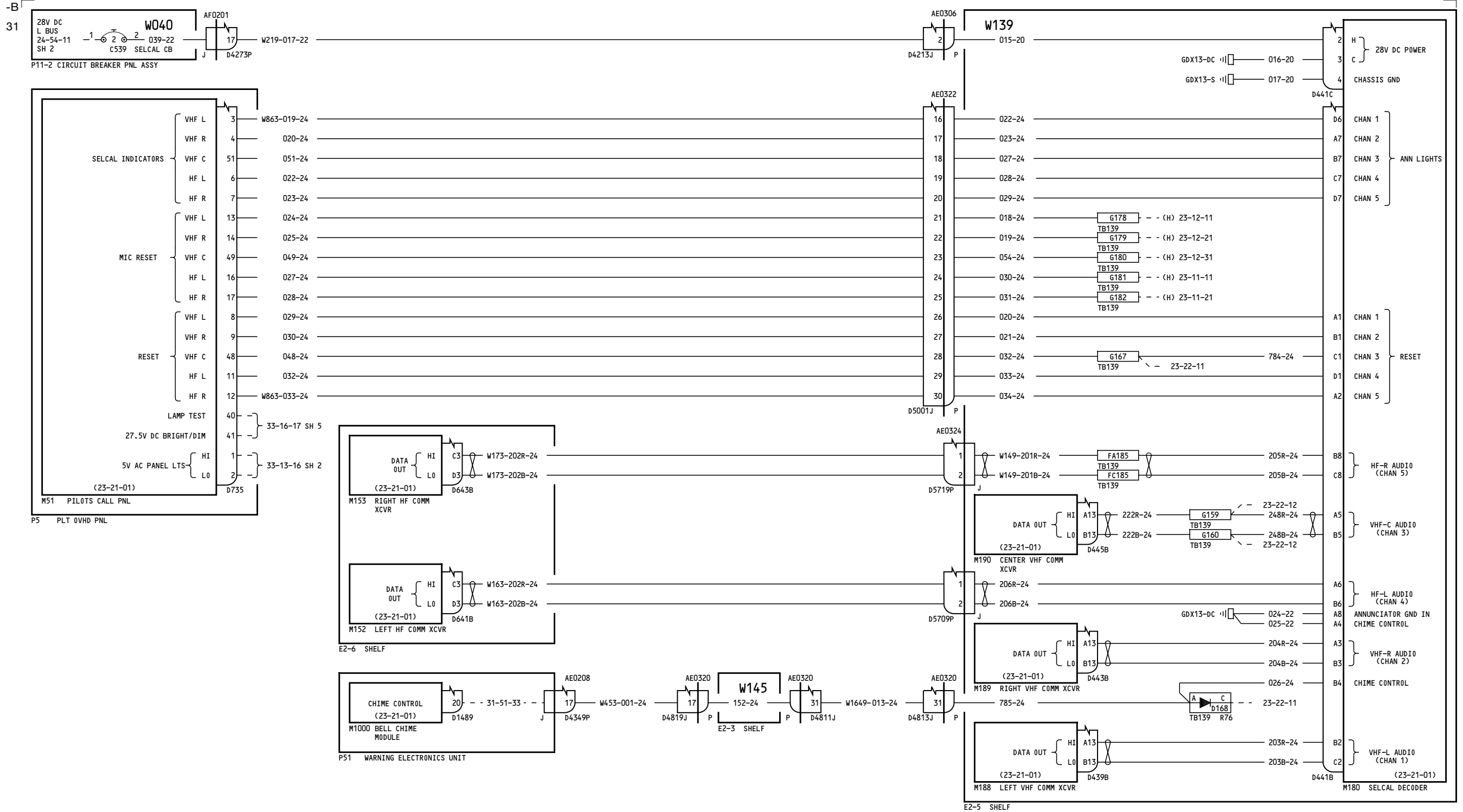

050-099

SELCAL

23-21-11

Page 1

D280T132

Jan 21/2005

23-21-11

Page 1

Jan 21/2005

-B
118

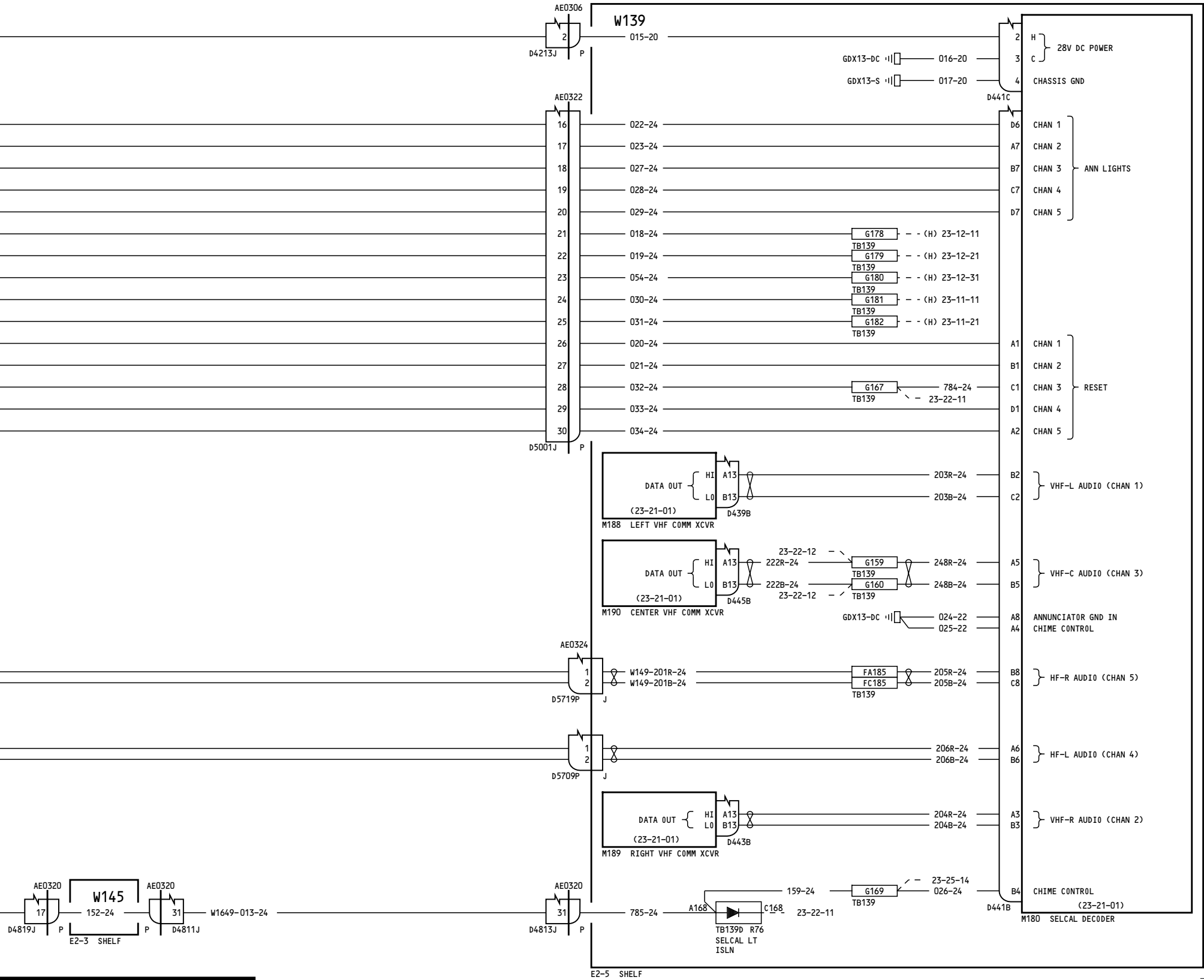
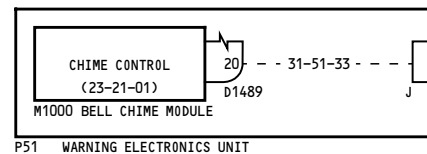
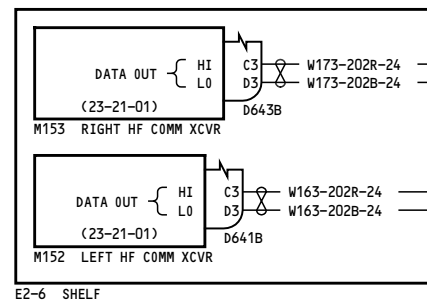
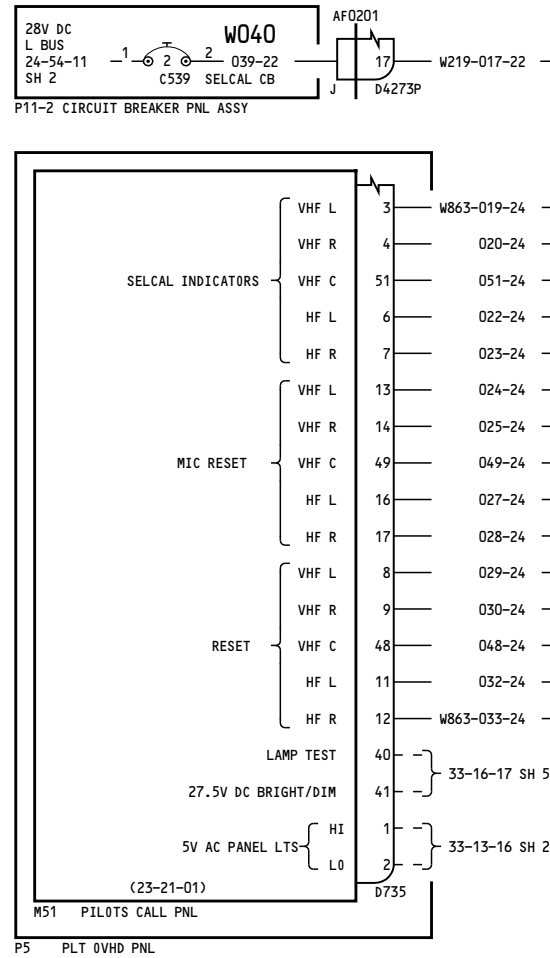

150, 153-154

SELCAL

D280T132

23-21-11

Page 2A

Jan 21/2005

Incorporates
MTO 230593
MTO-230607

23-21-11

Page 2A

Jan 21/2005

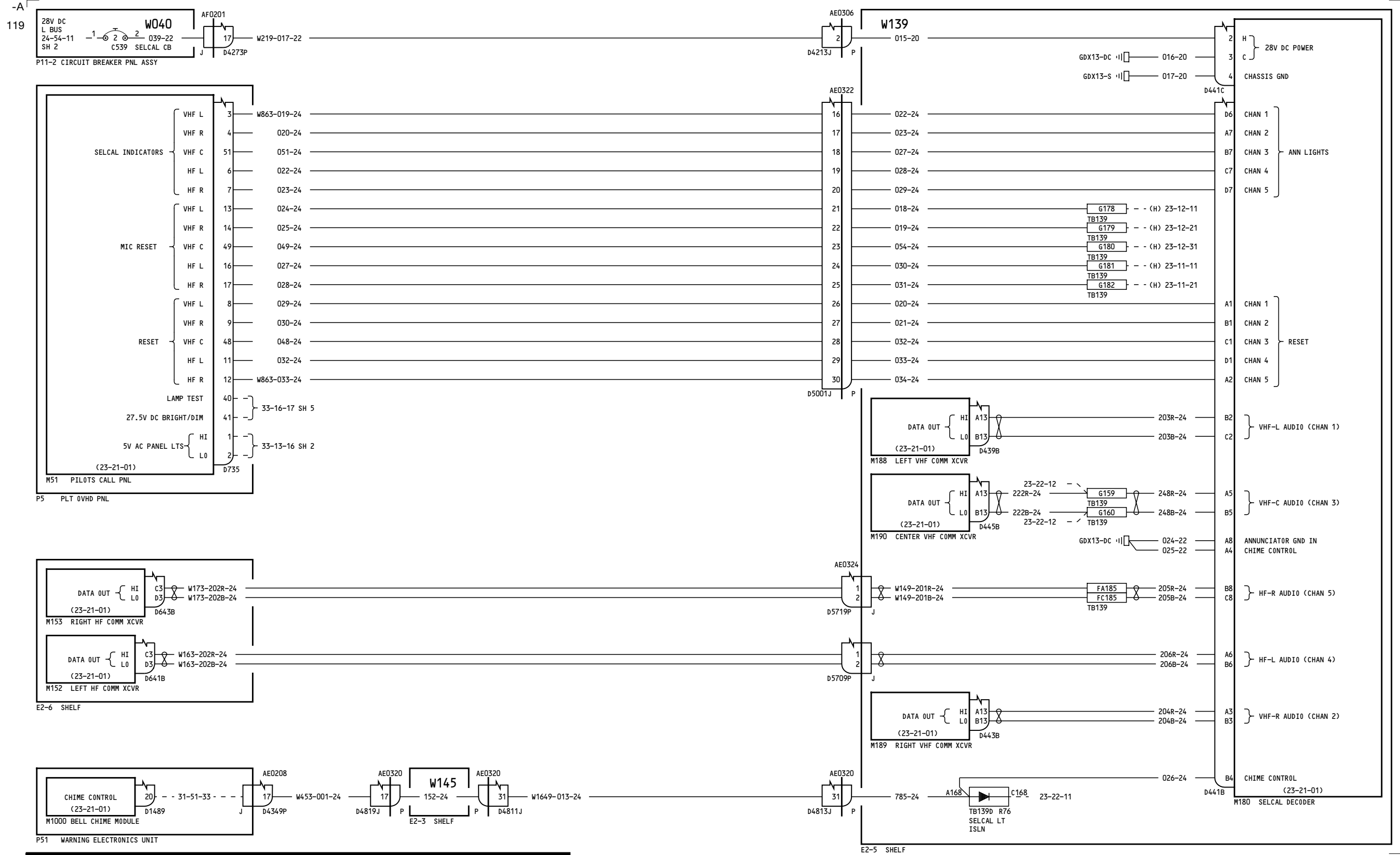

151

SELCAL

23-21-11

Page 3

Jan 21/2005

D280T132

23-21-11

Page 3

Jan 21/2005

141

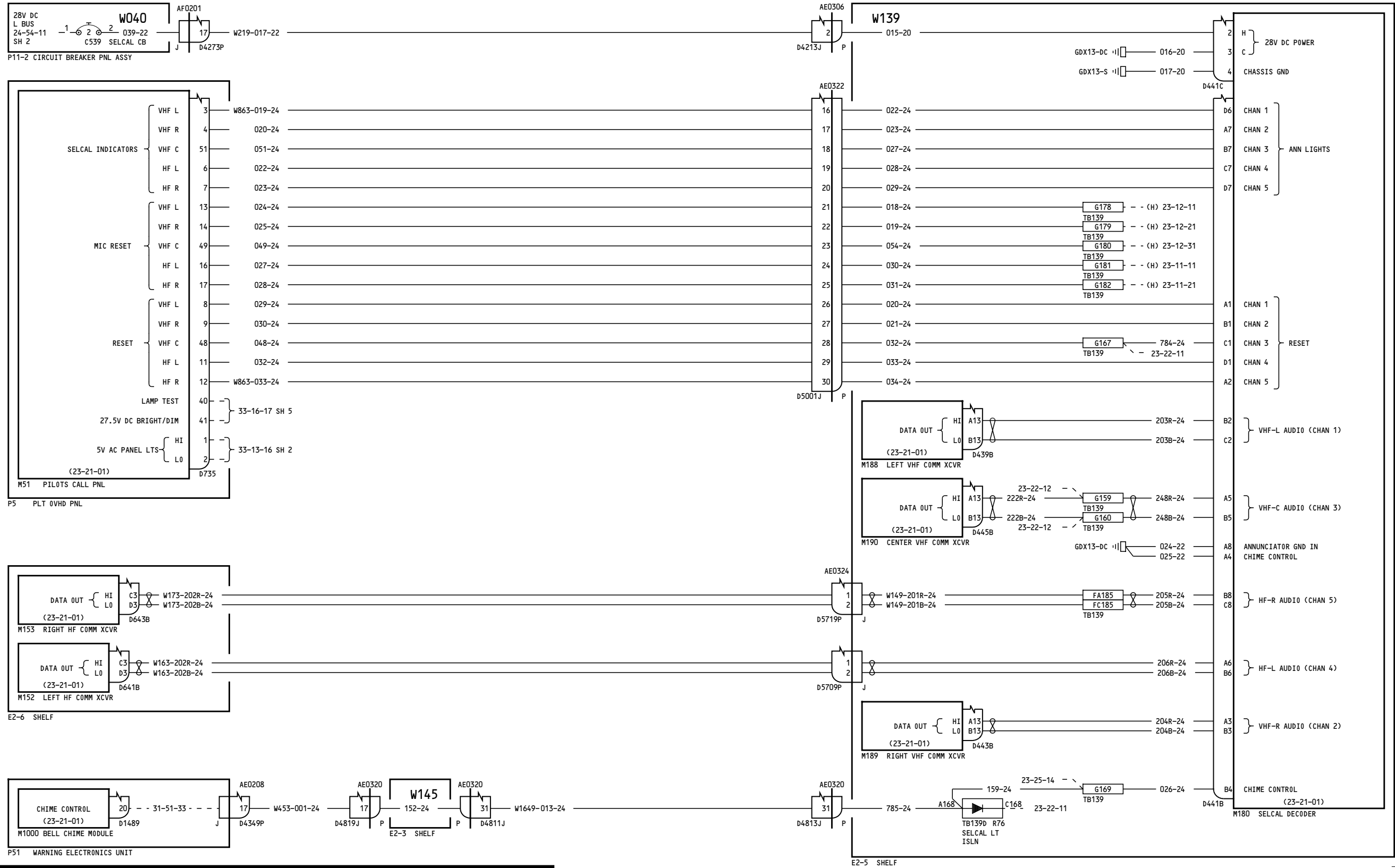

152

SELCAL
D280T132

23-21-11

Page 4A

Jan 21/2005

Incorporates
MTO-230607

23-21-11

Page 4A

Jan 21/2005

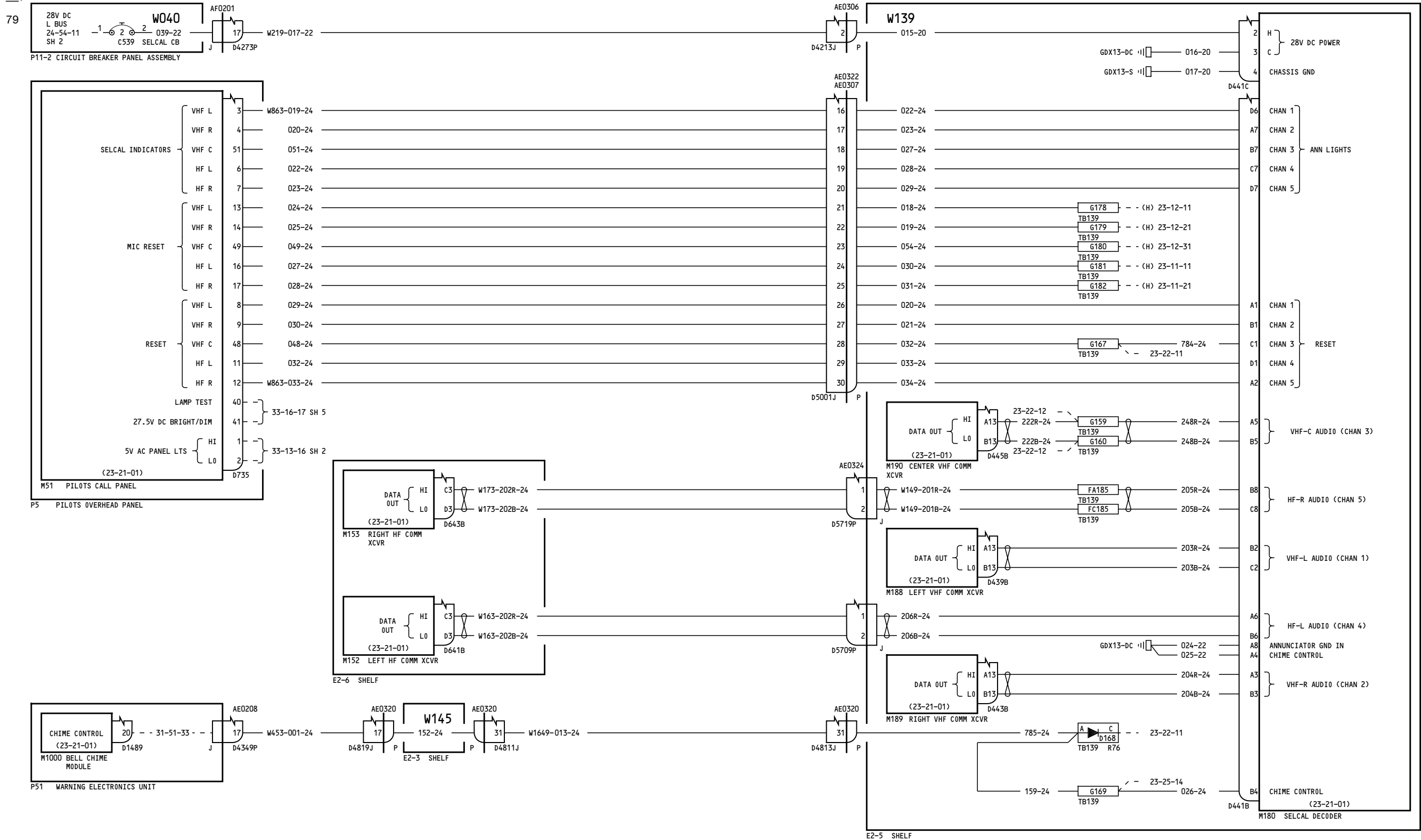

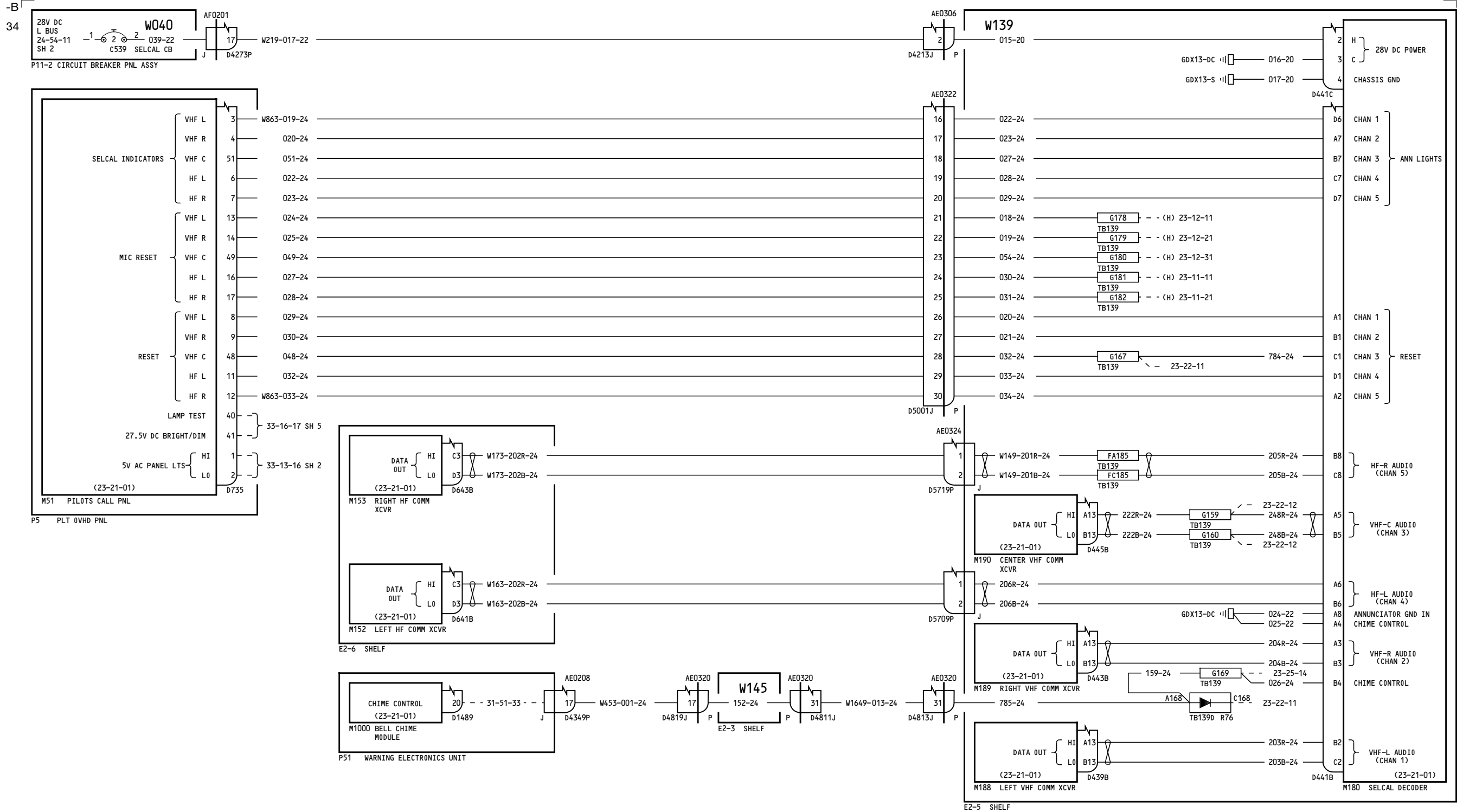

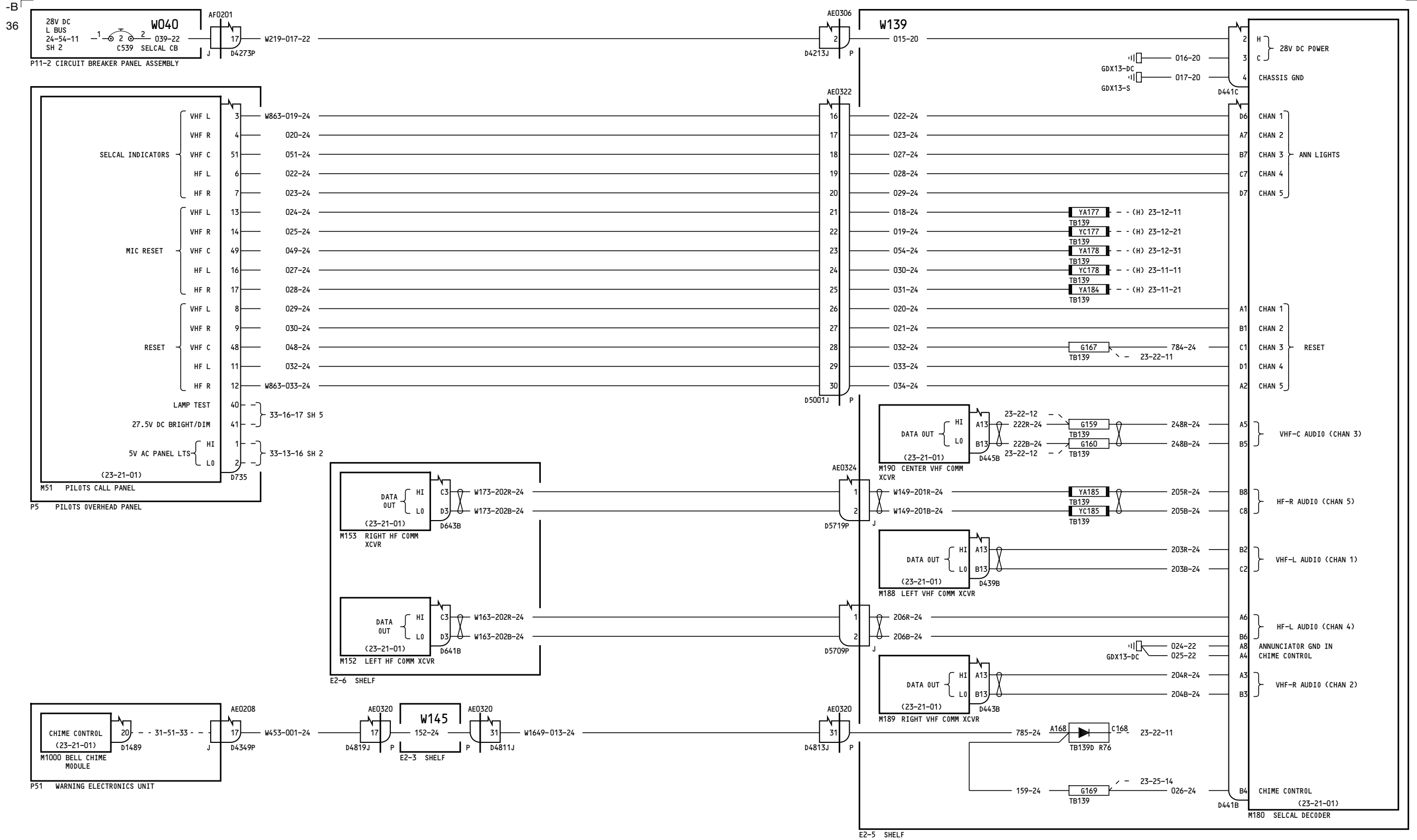

157, 167-199, 277-299

SELCAL

23-21-11

Page 7

Jan 21/2005

D280T132

23-21-11

Page 7

Jan 21/2005

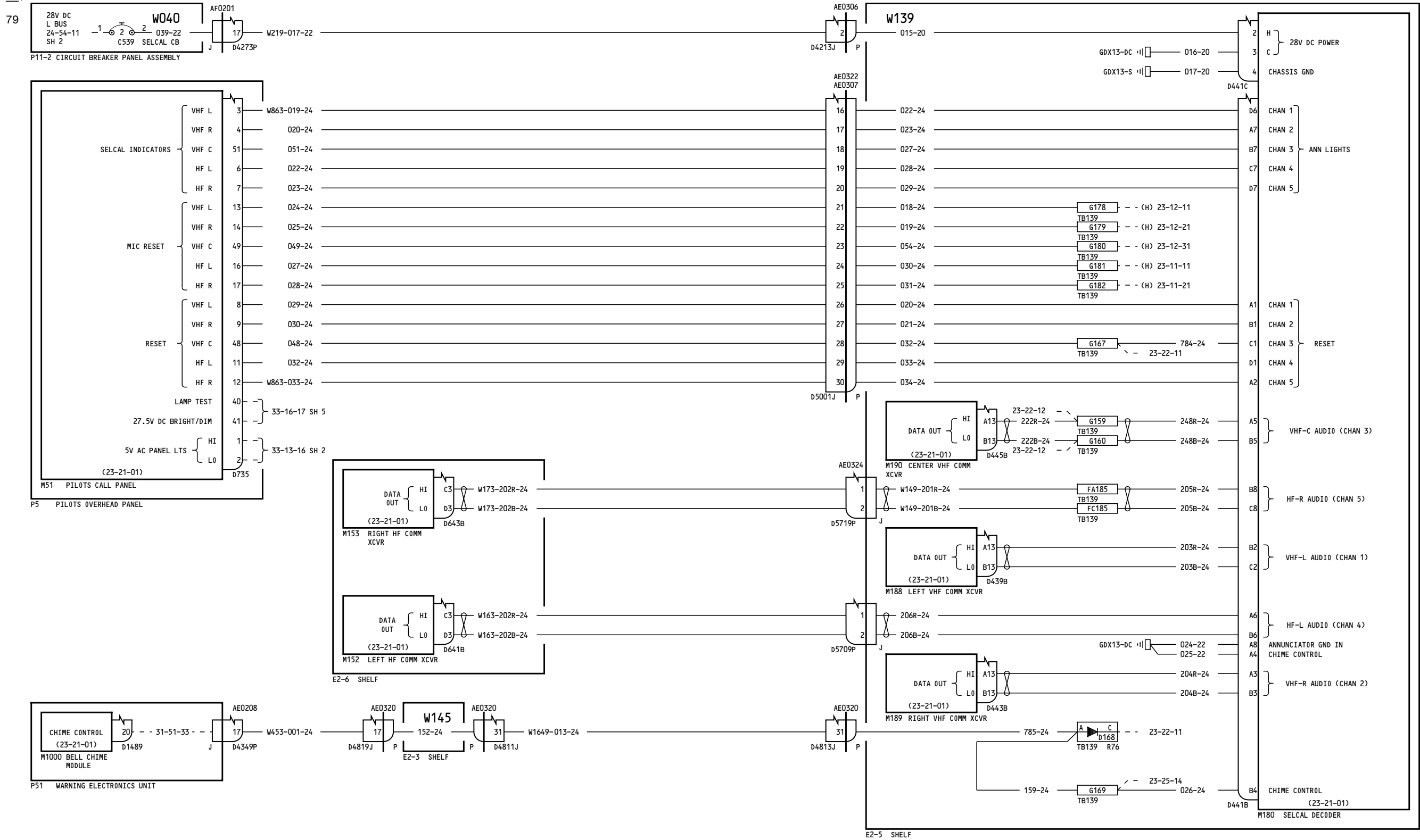

162-165

SELCAL

23-21-11

Incorporates
MTO 230592

23-21-11

Page 8A

Page 8A

D280T132

Jan 21/2005

Jan 21/2005

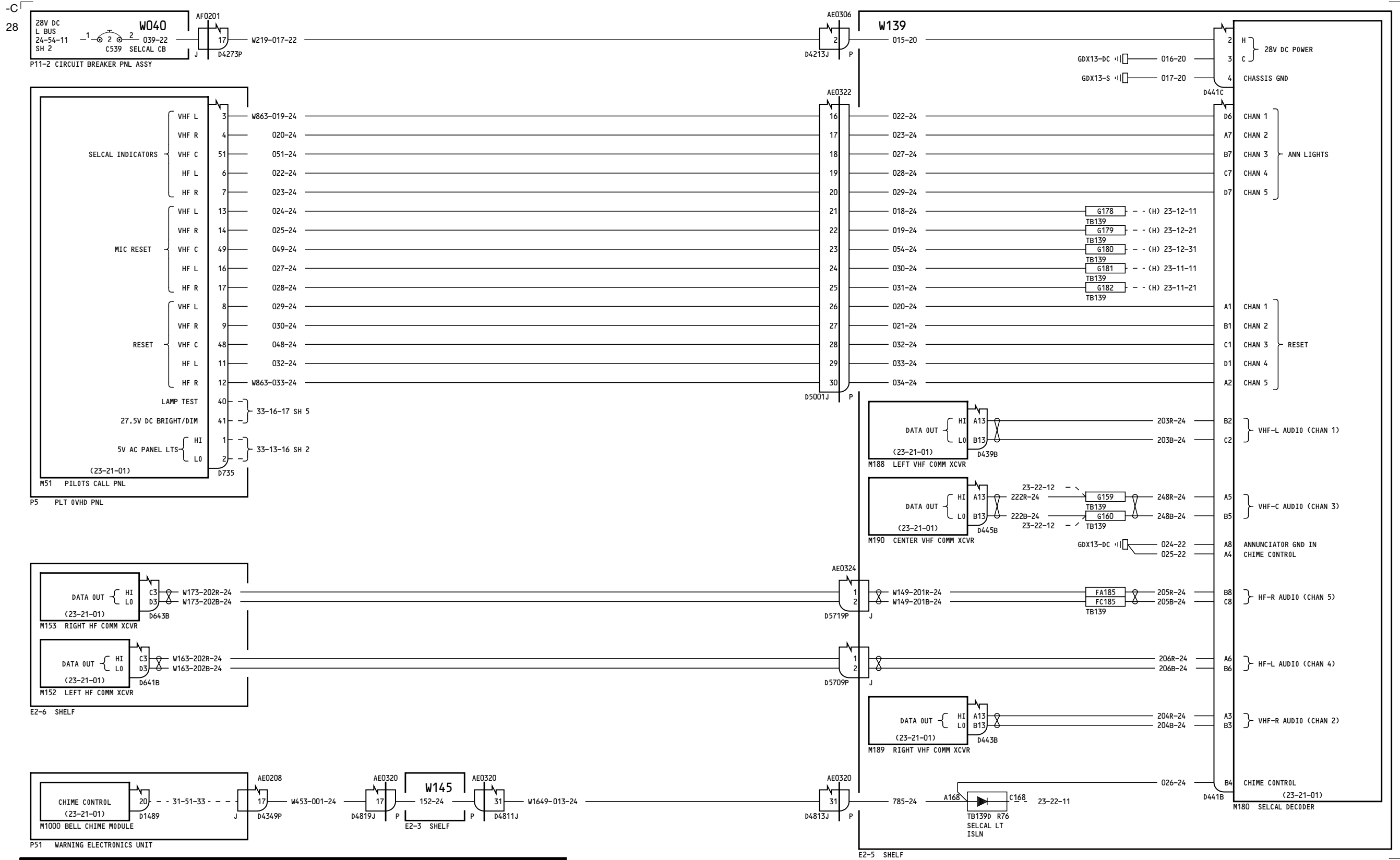

275-276

SELCAL

D280T132

23-21-11

Page 9

Jan 21/2005

23-21-11

Page 9

Jan 21/2005

69

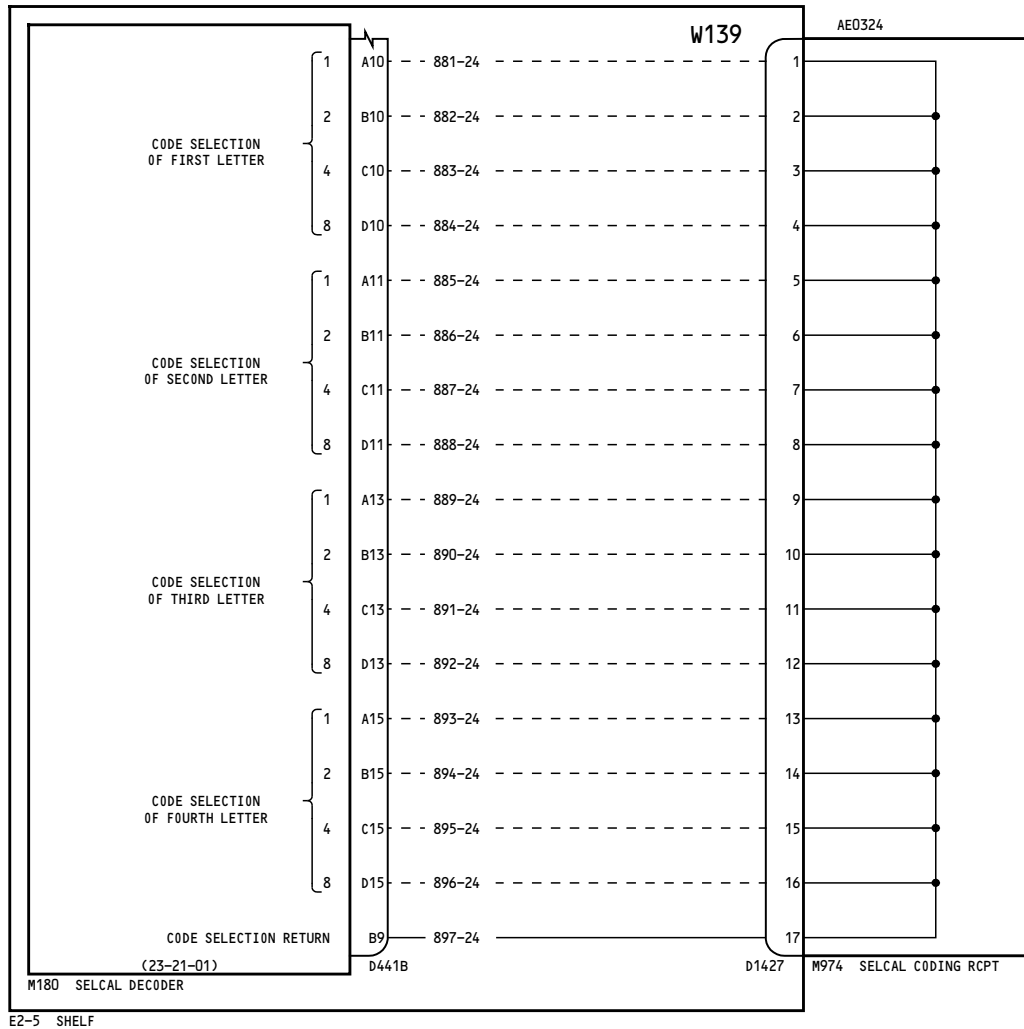

E2-5 SHELF



NOTES:

1 SEE WIRING CHART FOR HOOK-UP INFORMATION.
LOGIC "0" -INSTALL THE WIRES
LOGIC "1" TAPE AND STOW WIRE AT D1427

ALL	SELCAL CODING
	D280T132

23-21-12

Page 1

Jan 21/2005

AIRPLANE	CODE	WIRE NO.	CODE SELECTION LETTER															
			FIRST			SECOND			THIRD			FOURTH						
			881-24	882-24	883-24	884-24	885-24	886-24	887-24	888-24	889-24	890-24	891-24	892-24	893-24	894-24	895-24	896-24
VF071	BF-CK		0	1	0	0	0	1	1	0	1	1	0	0	0	1	0	1
VF072	BF-CM		0	1	0	0	0	1	1	0	1	1	0	0	0	0	1	1
VF073	GR-AB		1	1	1	0	1	1	1	1	1	0	0	0	0	1	0	0
VF090	GR-AB		1	1	1	0	1	1	1	1	1	0	0	0	0	1	0	0
VN151	BC-HJ		0	1	0	0	1	1	0	0	0	0	0	1	1	0	0	1
VN152	BM-GL		0	1	0	0	0	0	1	1	1	1	1	0	1	1	0	1
VN153	CD-BL		0	1	0	0	0	0	1	0	0	1	0	0	1	1	0	1
VN154	BF-CD		0	1	0	0	0	1	1	0	1	1	0	0	0	0	1	0
VN155	BF-CG		0	1	0	0	0	1	1	0	1	1	0	0	1	1	1	0
VN156	EJ-DH		1	0	1	0	1	0	0	1	0	0	1	0	0	0	1	0
VN157	FL-DM		0	1	1	0	1	1	0	1	0	0	1	0	0	0	1	1
VN158	EH-FJ		1	0	1	0	0	0	0	1	0	1	1	0	1	0	0	1
VN159	GR-AB		1	1	1	0	1	1	1	1	1	0	0	0	0	1	0	0
VN160	GR-AB		1	1	1	0	1	1	1	1	1	0	0	0	0	1	0	0
VN161	GR-AB		1	1	1	0	1	1	1	1	1	0	0	0	0	1	0	0
VN162	GR-AB		1	1	1	0	1	1	1	1	1	0	0	0	0	1	0	0
VN163	BF-DE		0	1	0	0	0	1	1	0	0	0	1	0	1	1	0	1
VN164	BF-DL		0	1	0	0	0	1	1	0	0	0	1	0	1	1	0	1
VN166	BF-EJ		0	1	0	0	0	1	1	0	1	0	1	0	1	0	0	1
VN167	JL-CH		1	0	0	1	1	1	0	1	1	1	0	0	0	0	0	1
VN168	CG-JL		1	1	0	0	1	1	1	0	1	0	0	1	1	1	0	1
VN169	GR-AB		1	1	1	0	1	1	1	1	1	0	0	0	0	1	0	0
VN170	GR-AB		1	1	1	0	1	1	1	1	1	0	0	0	0	1	0	0
VN221	CQ-BH		1	1	0	0	0	1	1	1	0	1	0	0	0	0	0	1
VN222	CQ-BJ		1	1	0	0	0	1	1	1	0	1	0	0	1	0	0	1
VN223	AR-LM		1	0	0	0	1	1	1	1	1	1	0	1	0	0	1	1
VN224	CE-BS		1	1	0	0	1	0	1	0	0	1	0	0	0	0	0	0
VN225	GR-AB		1	1	1	0	1	1	1	1	1	0	0	0	0	1	0	0
VN226	GR-AB		1	1	1	0	1	1	1	1	1	0	0	0	0	1	0	0
VN227	GR-AB		1	1	1	0	1	1	1	1	1	0	0	0	0	1	0	0
VN228	GR-AB		1	1	1	0	1	1	1	1	1	0	0	0	0	1	0	0
VN229	GR-AB		1	1	1	0	1	1	1	1	1	0	0	0	0	1	0	0
VN230	GR-AB		1	1	1	0	1	1	1	1	1	0	0	0	0	1	0	0
VN671	AR-KS		1	0	0	0	1	1	1	1	0	1	0	1	0	0	0	0
VN672	BJ-PR		0	1	0	0	1	0	0	1	1	0	1	1	1	1	1	1
VN673	GR-AB		1	1	1	0	1	1	1	1	1	0	0	0	0	1	0	0
VN674	GR-AB		1	1	1	0	1	1	1	1	1	0	0	0	0	1	0	0
VN675	GR-AB		1	1	1	0	1	1	1	1	1	0	0	0	0	1	0	0

23-21-12

Page 1

Jan 21/2005

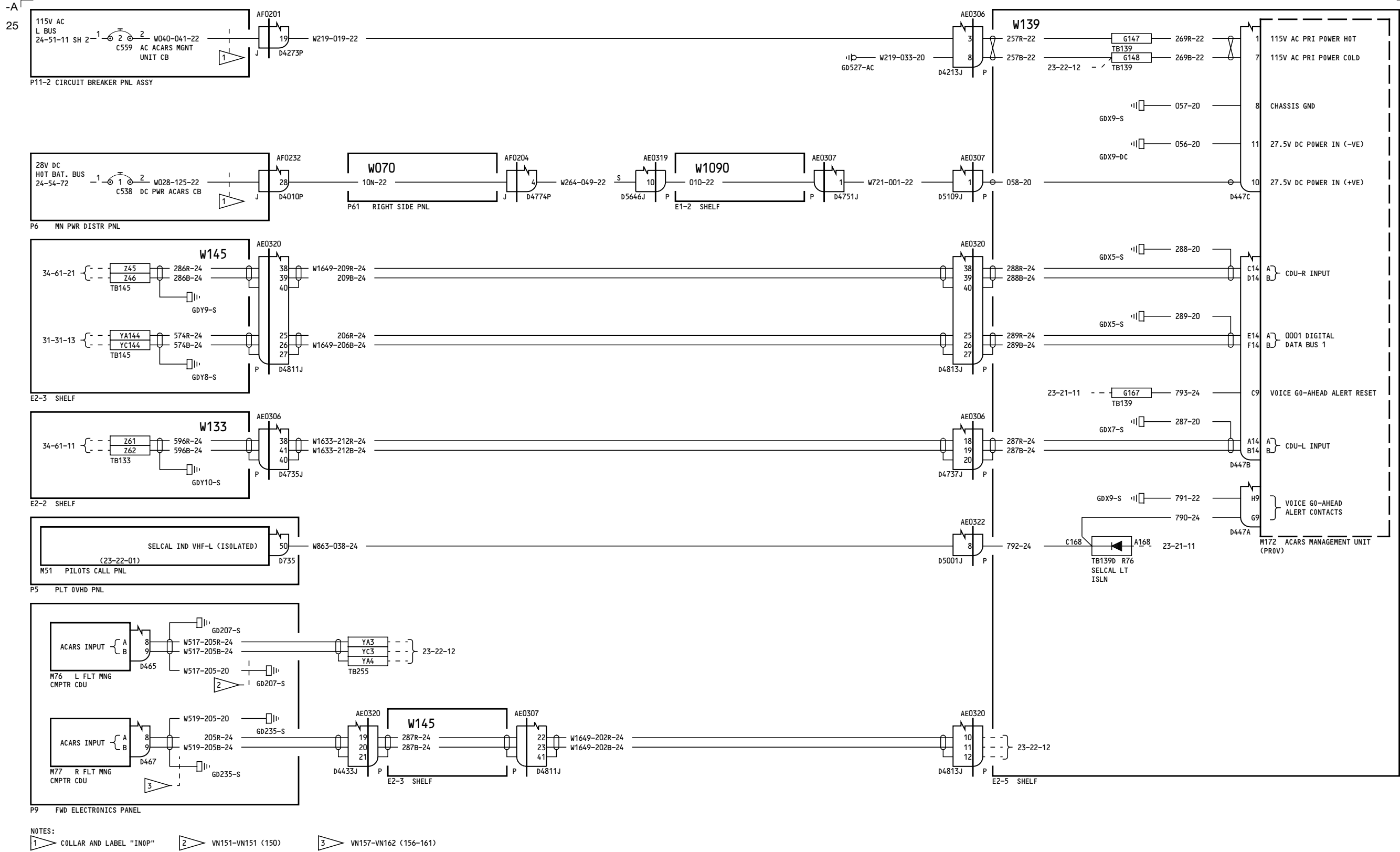

050-099, 151

**ACARS-
POWER CONTROL & OOOI**

23-22-11

Page 1

D280T132

Jan 21/2005

23-22-11

Page 1

Jan 21/2005

191

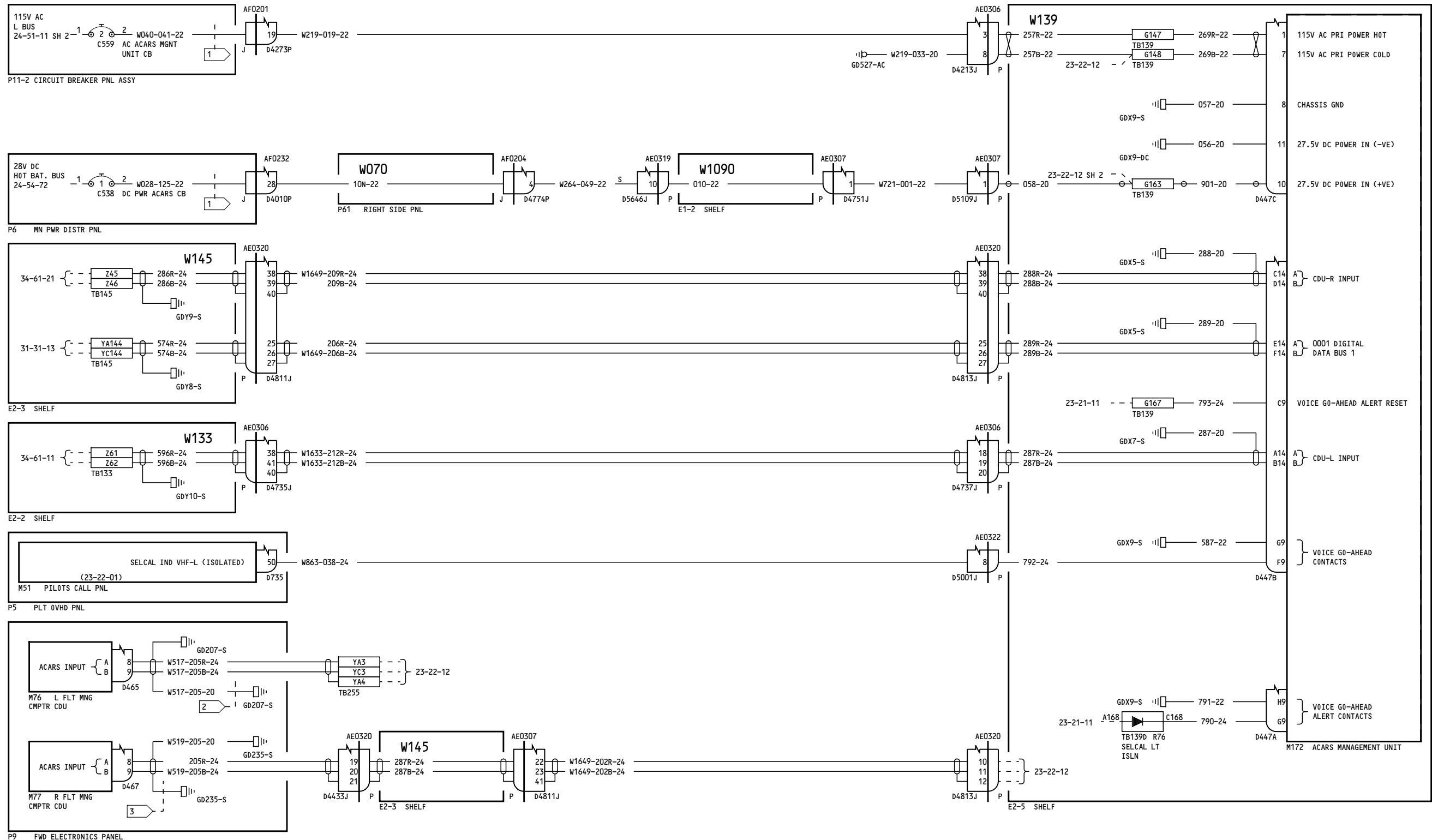

NOTES:
 1 COLLAR AND LABEL "IN0P" 2 VN151-VN151 (150) 3 VN157-VN162 (156-161)

150, 152-166

**ACARS-
POWER CONTROL & OOOI**

D280T132

23-22-11

Page 2A
Jan 21/2005

Incorporates
MTO-230607

23-22-11

Page 2A
Jan 21/2005

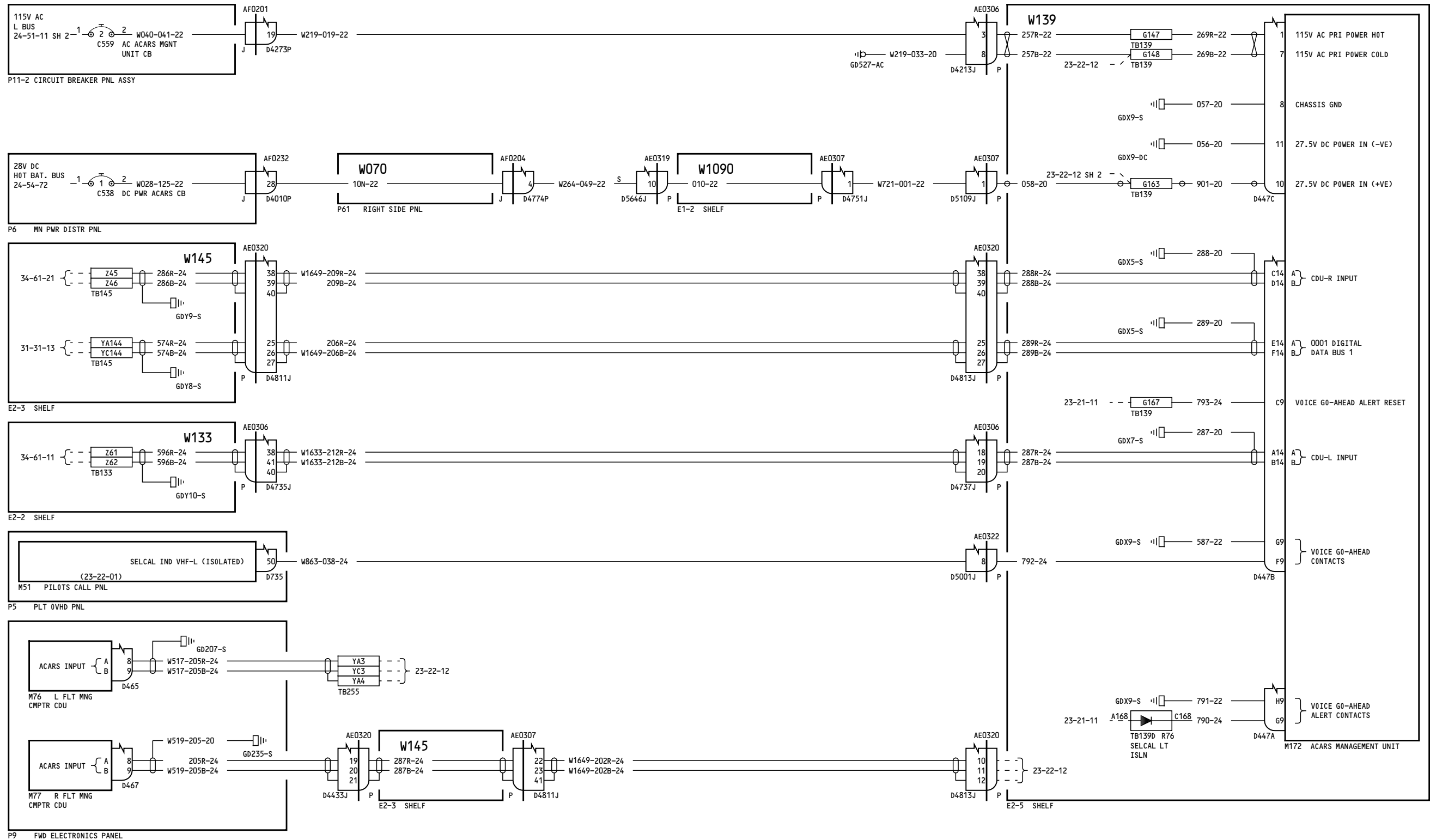

171

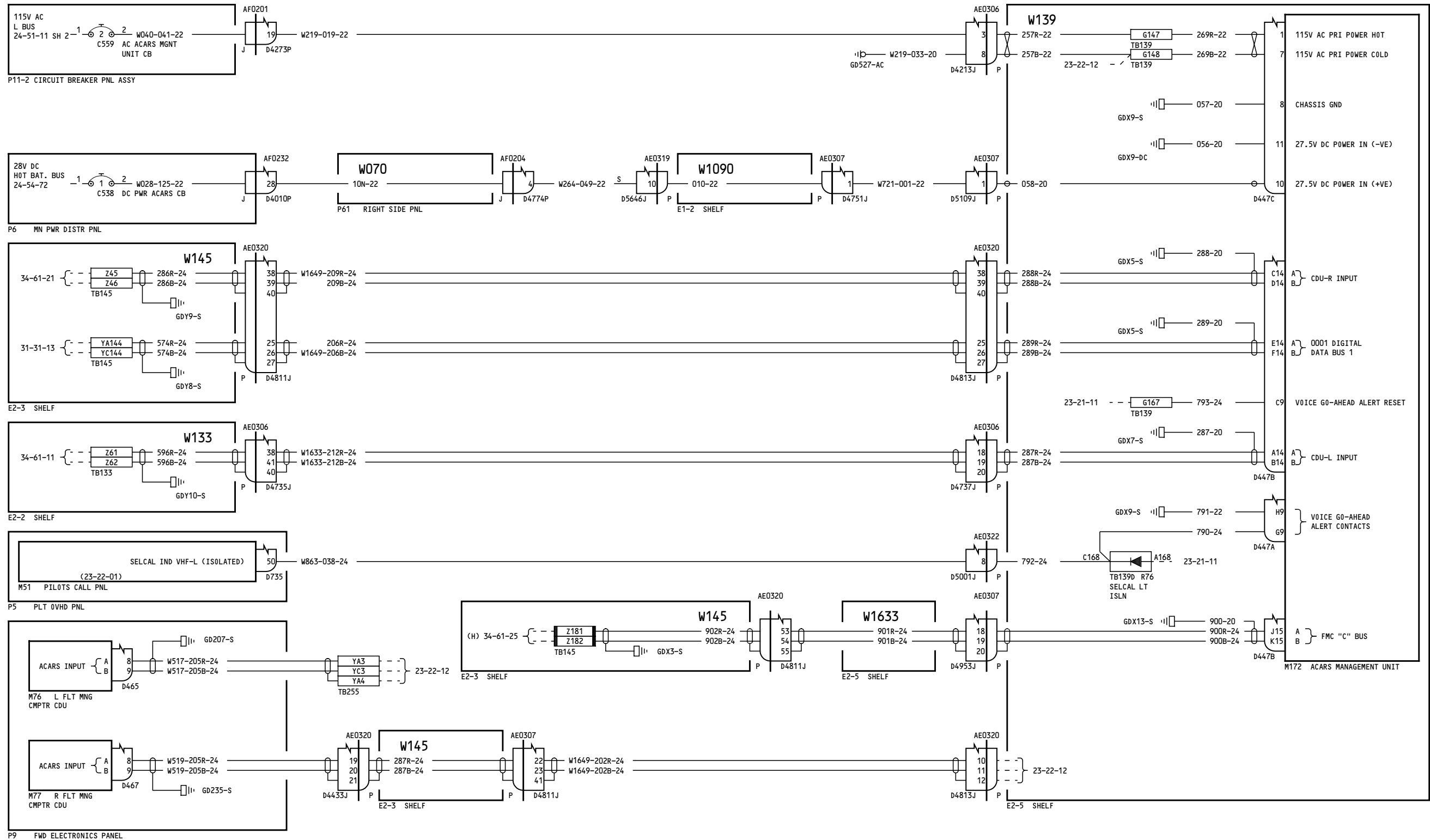

275-276

**ACARS-
POWER CONTROL & OOOI**

23-22-11

Page 4A

D280T132

Jan 21/2005

Incorporates
MTO-230589

23-22-11

Page 4A

Jan 21/2005

172

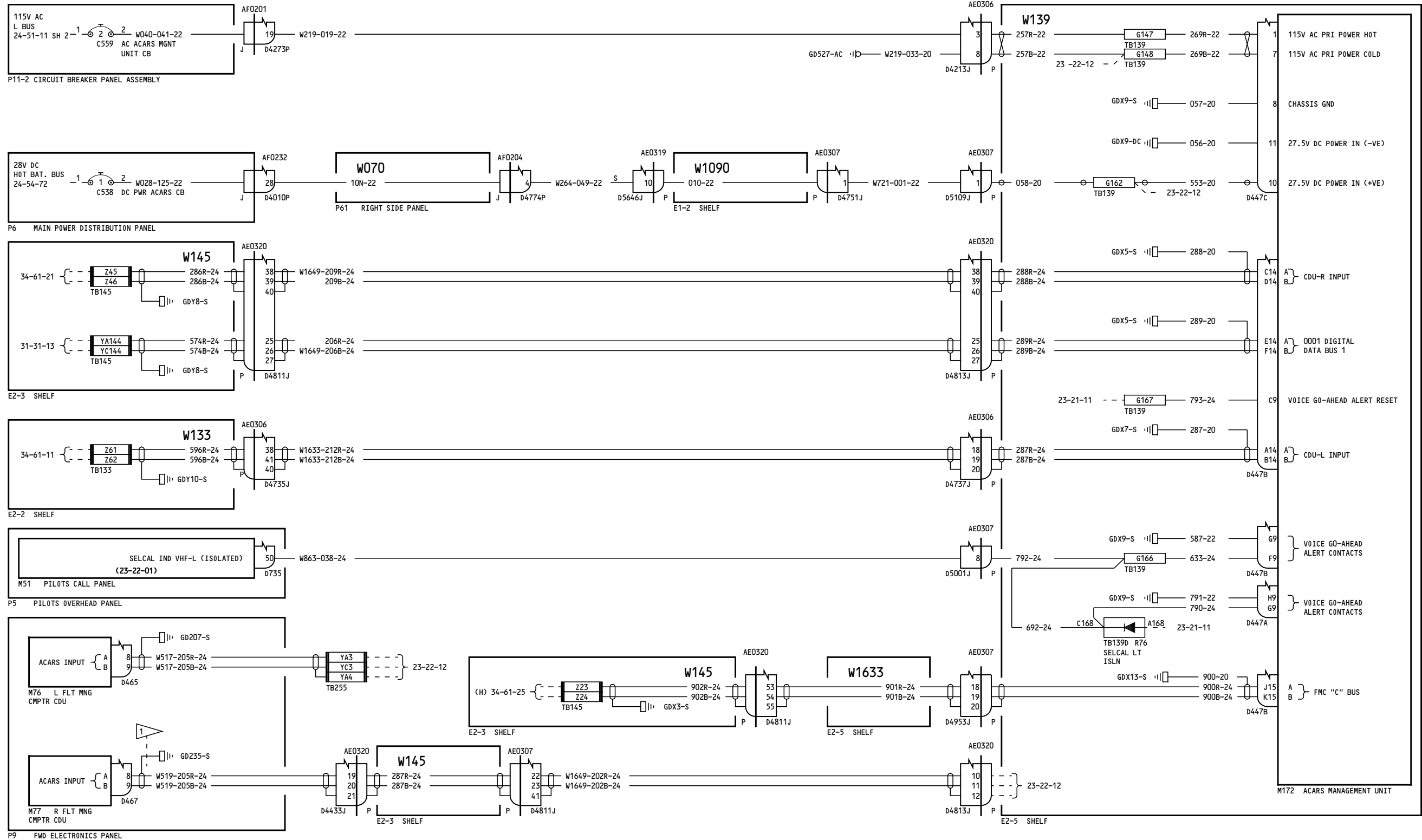

NOTES:
 1 MAXIMUM LENGTH OF GROUND WIRES NO TO EXCEED 18 INCHES

277-278

**ACARS-
POWER CONTROL & OOOI**

D280T132

23-22-11

Page 5A

Jan 21/2005

Incorporates
 MTO-230589

23-22-11

Page 5A

Jan 21/2005

173

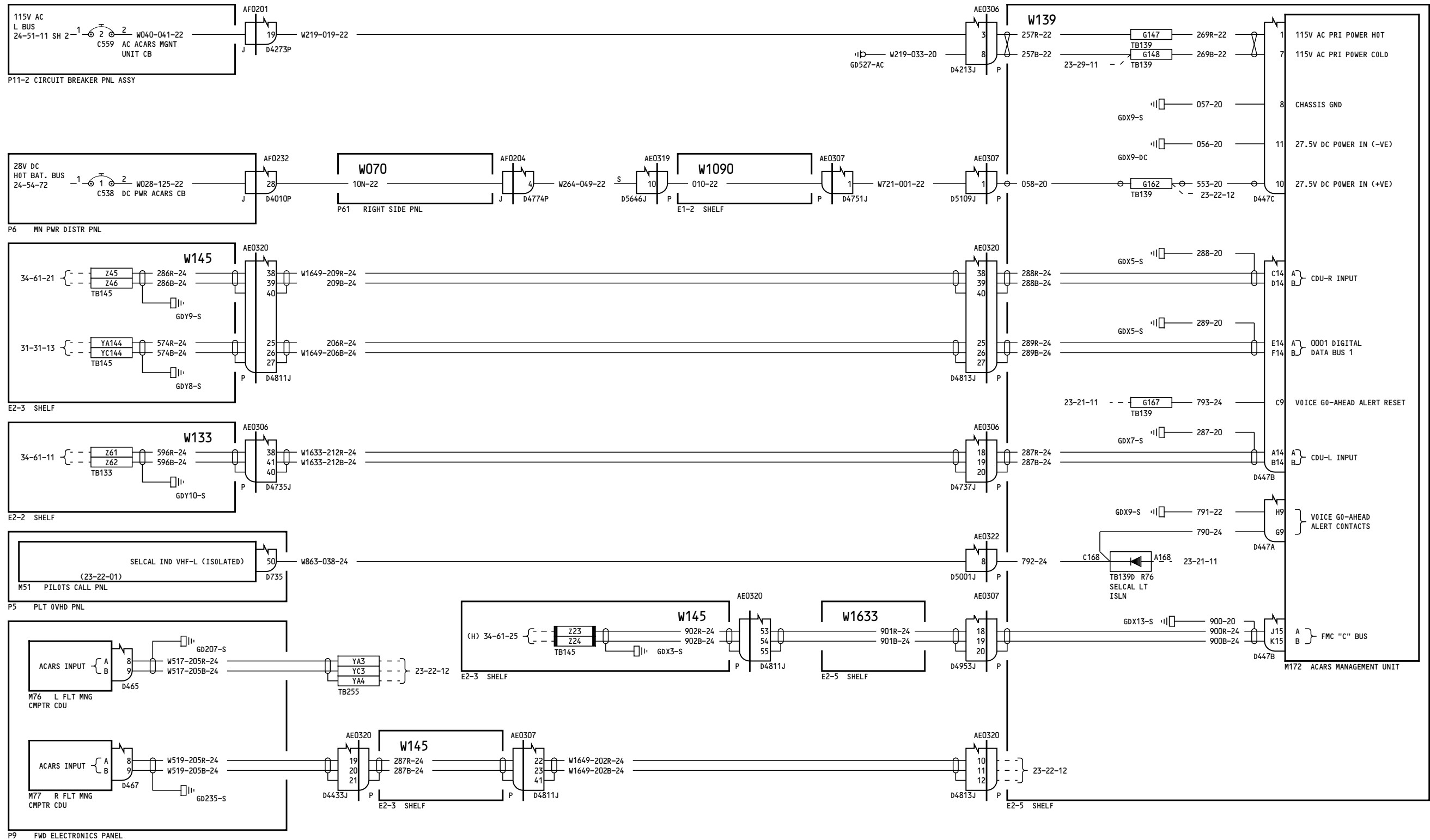

280

ACARS-
POWER CONTROL & OOOI

23-22-11

Page 6A

D280T132

Jan 21/2005

Incorporates
MTO-230589

23-22-11

Page 6A

Jan 21/2005

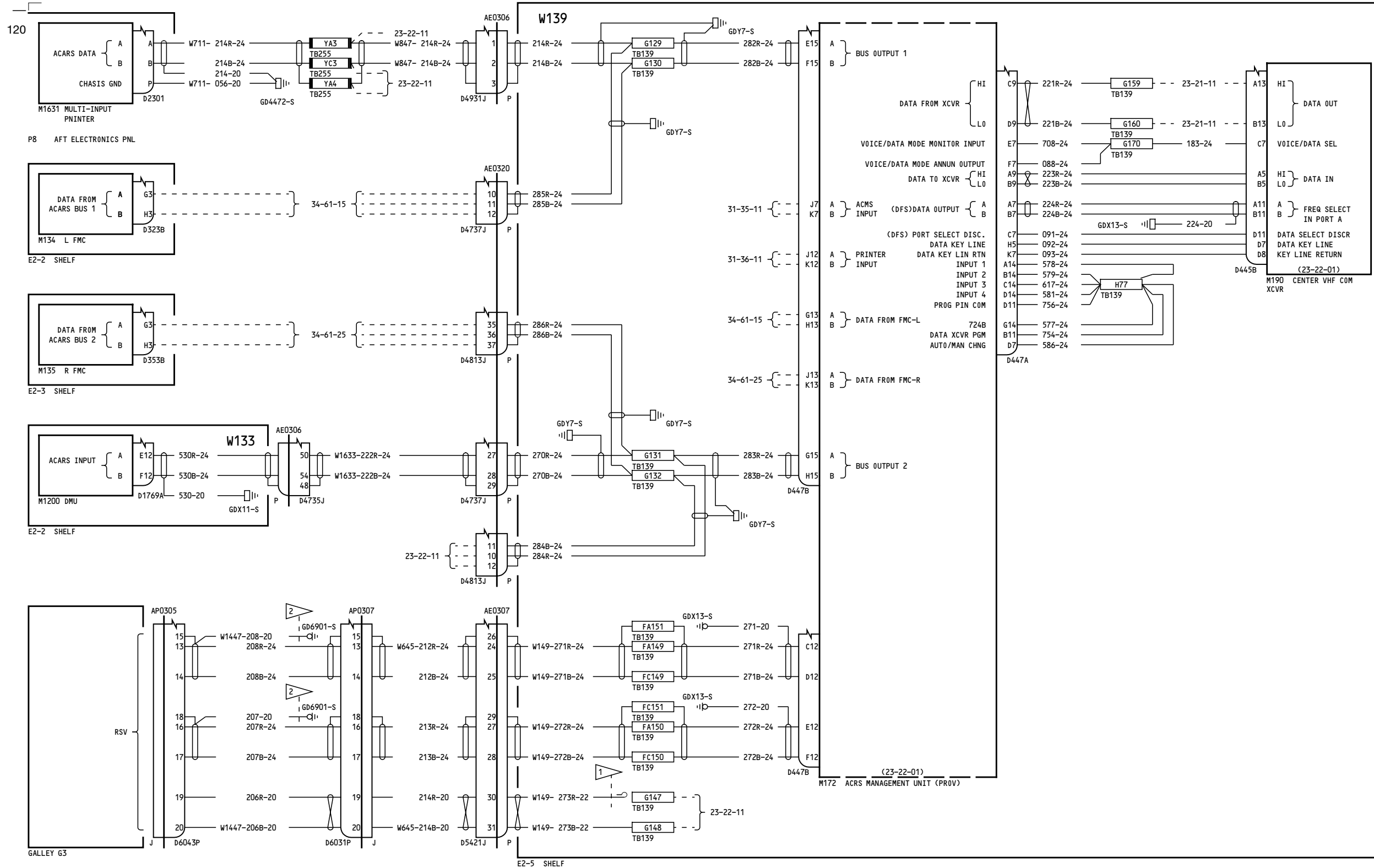

1 CAP & STOW NEAR TB139G 2 MAX LENGTH OF GND WIRES NOT TO EXCEED 18 INCHES

050-051

ACARS, DFDAU, FLIGHT MANAGEMENT COMPUTER INTERFACE

D280T132

23-22-12

Page 1A
Jan 21/2005

Incorporates
MTO 230540

23-22-12

Page 1A
Jan 21/2005

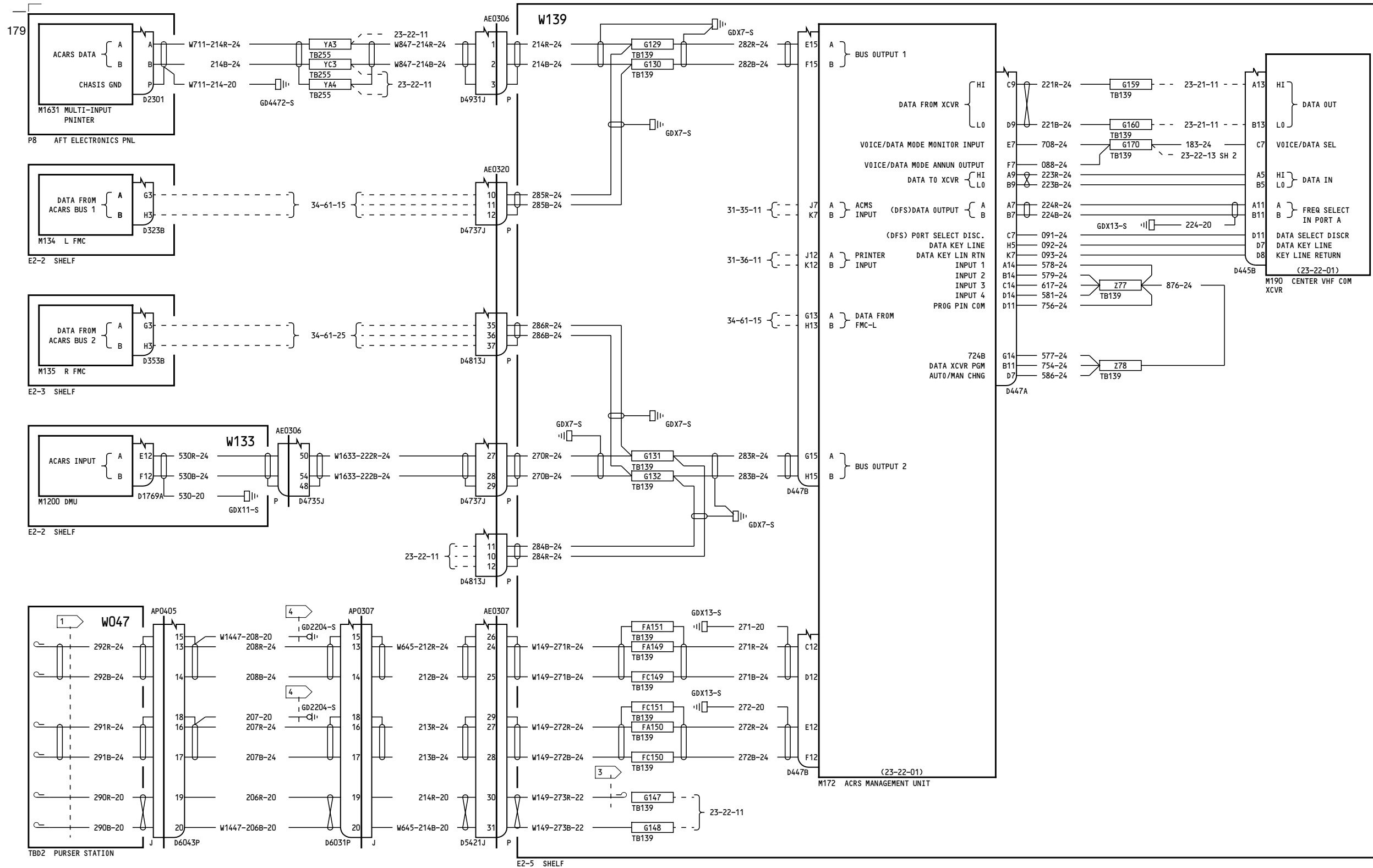

NOTES:
 1 CAP & STOW NEAR STA 467 3 CAP & STOW NEAR TB139 4 MAX LENGTH OF GND WIRES NOT TO EXCEED 18 INCHES

150, 152

ACARS, DFDU, FLIGHT MANAGEMENT COMPUTER INTERFACE

D280T132

23-22-12

Page 2A
 Sheet 1
 Jan 21/2005

Incorporates
 MTO-230607

23-22-12

Page 2A
 Sheet 1
 Jan 21/2005

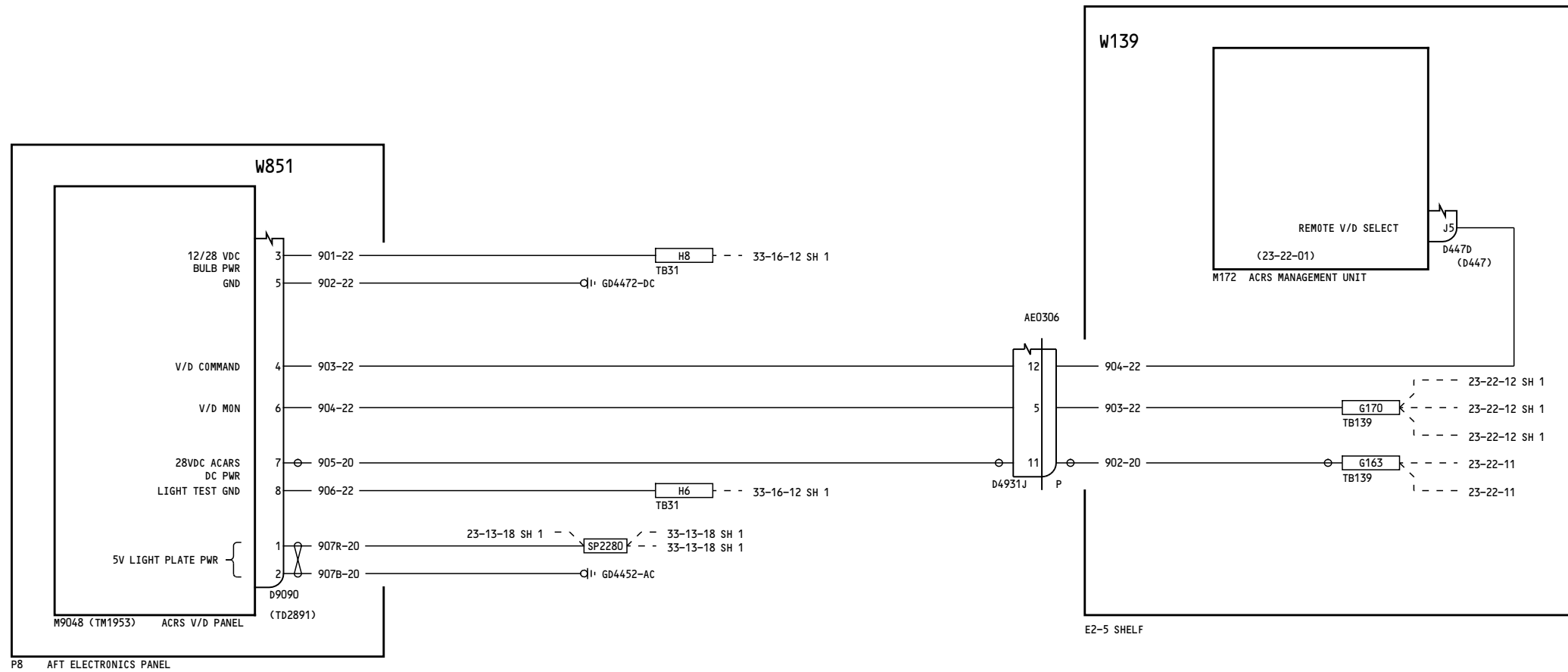

150, 152

**ACARS, DFDAU, FLIGHT
MANAGEMENT COMPUTER
INTERFACE**

D280T132

23-22-12

Page 2A
Sheet 2
Jan 21/2005

Incorporates
MTO-230607

23-22-12

Page 2A
Sheet 2
Jan 21/2005

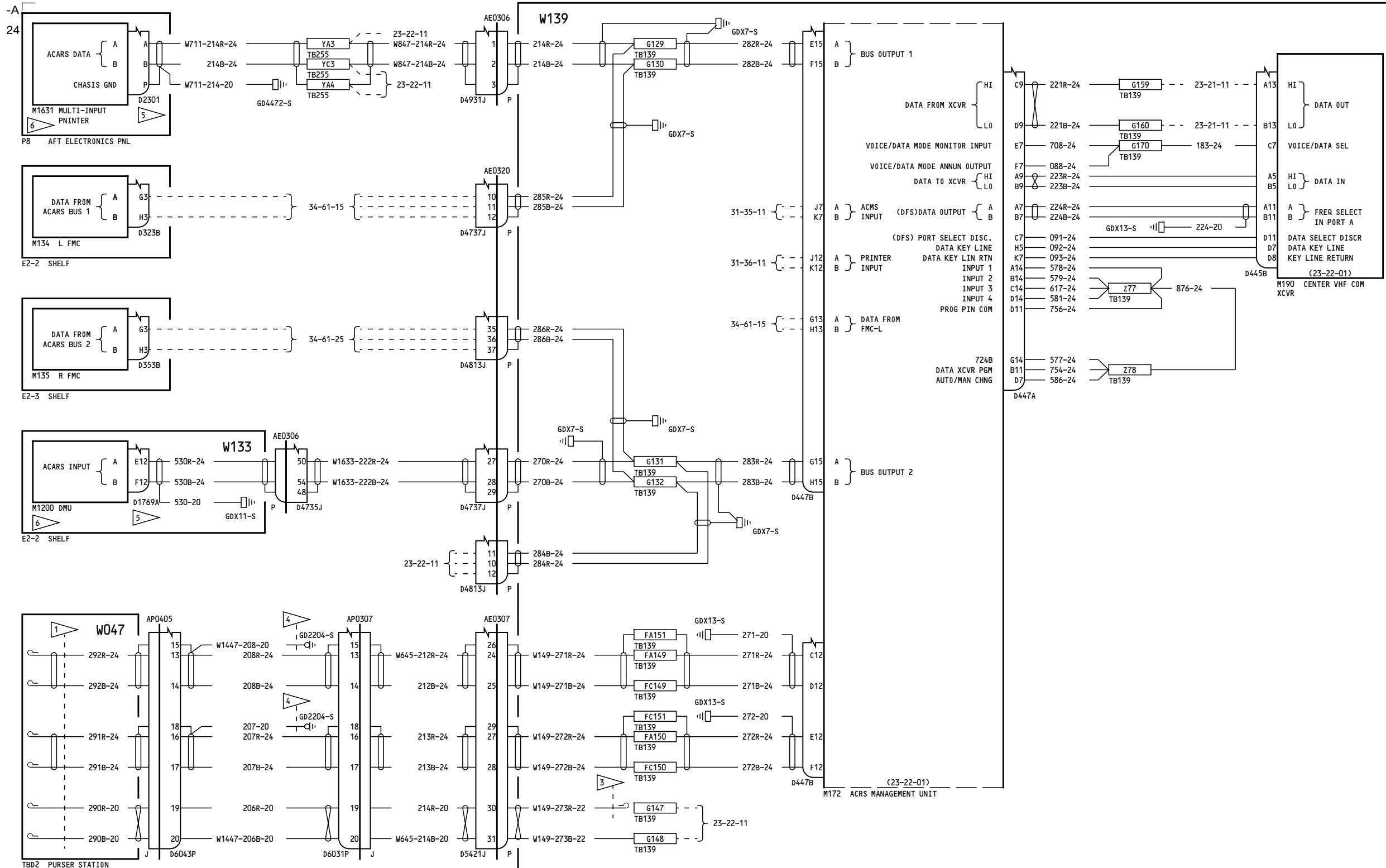

- NOTES:
- 1 CAP & STOW NEAR STA 467
 - 2 CAP & STOW NEAR TB139
 - 3 MAX LENGTH OF GND WIRES NOT TO EXCEED 18 INCHES
 - 4 CONNECTOR IS CAPPED AND STOWED FOR VN151-VN153 (150-152)
 - 5 EQUIPMENT IS PROVISIONAL FOR VN151-VN153 (150-152)

151

ACARS, DFDU, FLIGHT MANAGEMENT COMPUTER INTERFACE

D280T132

23-22-12

Page 3

Jan 21/2005

23-22-12

Page 3

Jan 21/2005

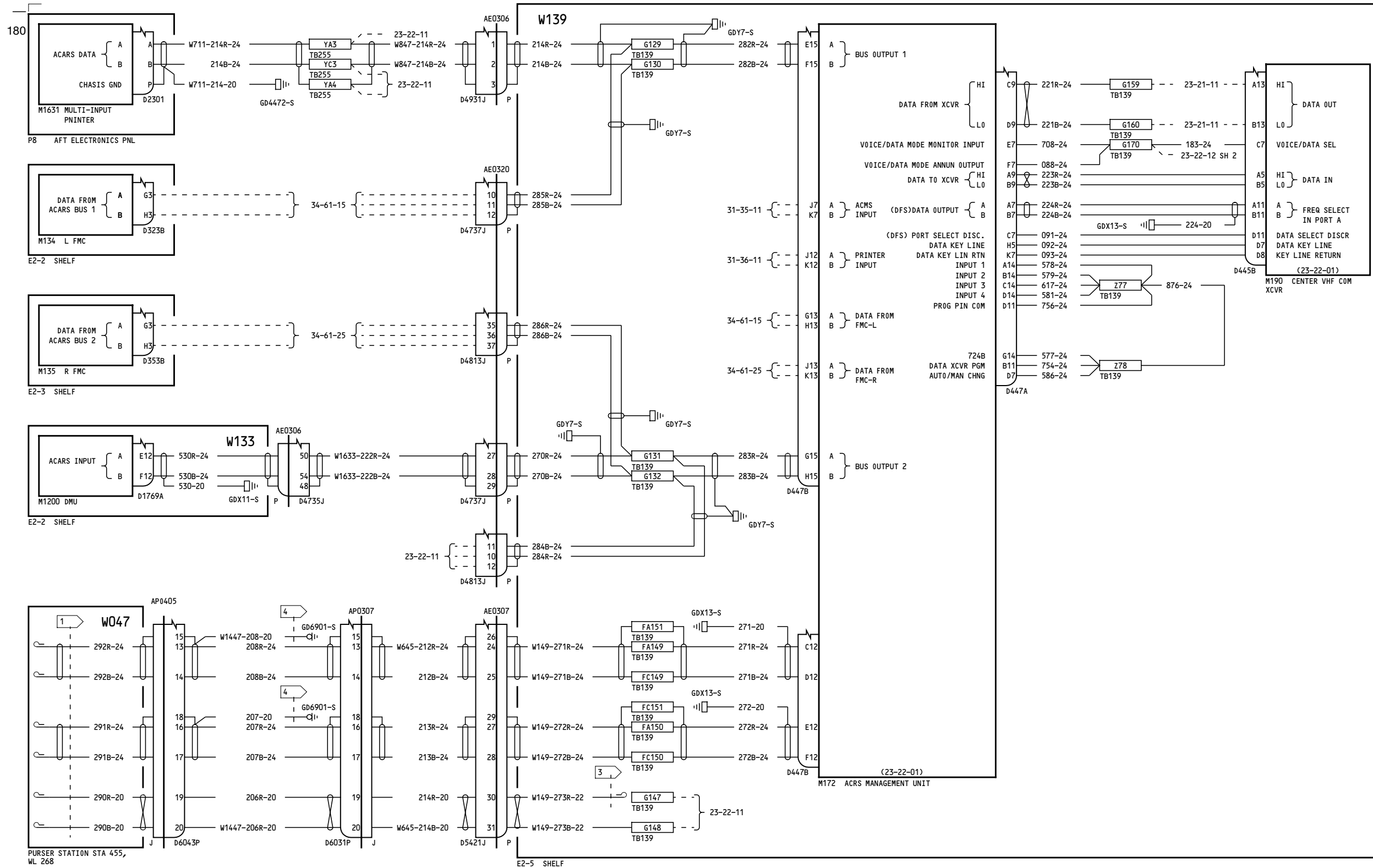

NOTES:
1 CAP & STOW NEAR STA 467 3 CAP & STOW NEAR TB139 4 MAX LENGTH OF GND WIRES NOT TO EXCEED 18 INCHES

153-155, 162-165

**ACARS, DFDU, FLIGHT
MANAGEMENT COMPUTER
INTERFACE**

D280T132

23-22-12

Page 4A
Sheet 1
Jan 21/2005

Incorporates
MTO-230607

23-22-12

Page 4A
Sheet 1
Jan 21/2005

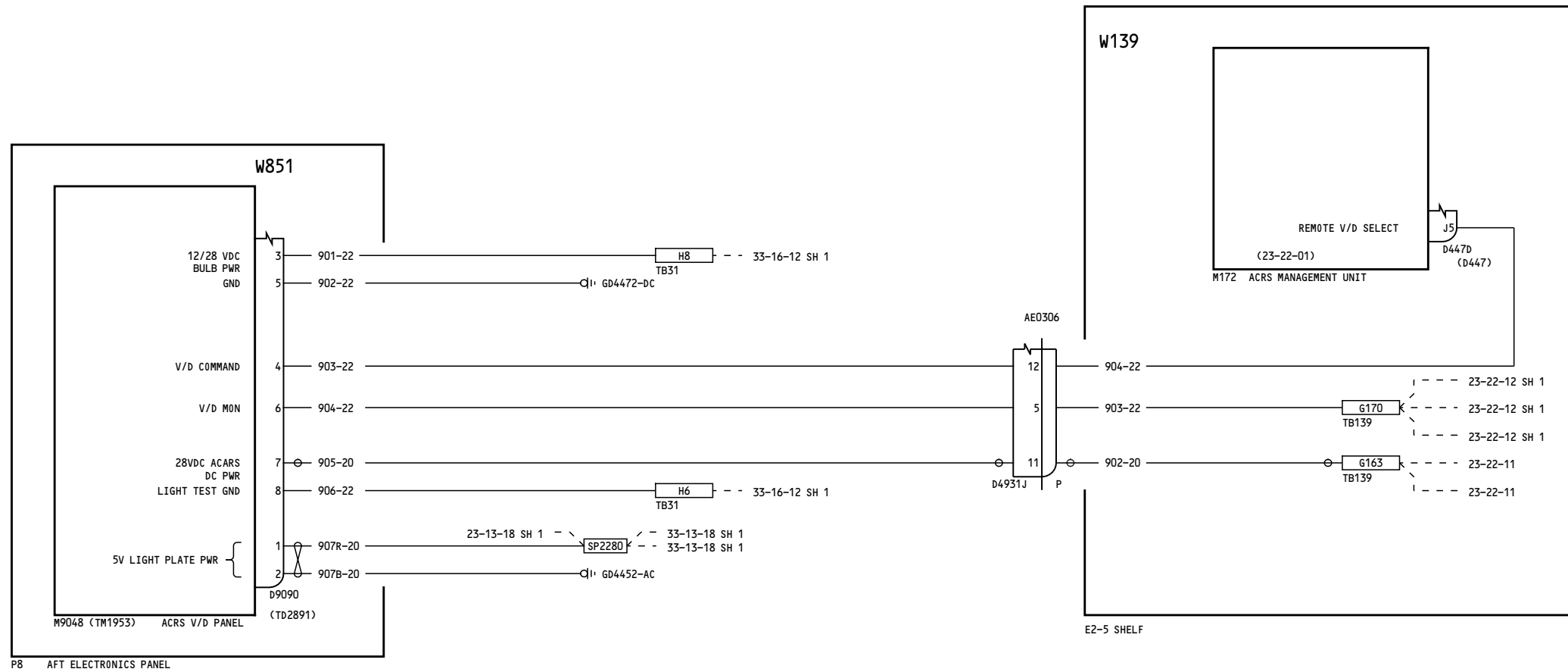

153-155, 162-165

**ACARS, DFDAU, FLIGHT
MANAGEMENT COMPUTER
INTERFACE**

D280T132

23-22-12

Page 4A
Sheet 2
Jan 21/2005

Incorporates
MTO-230607

23-22-12

Page 4A
Sheet 2
Jan 21/2005

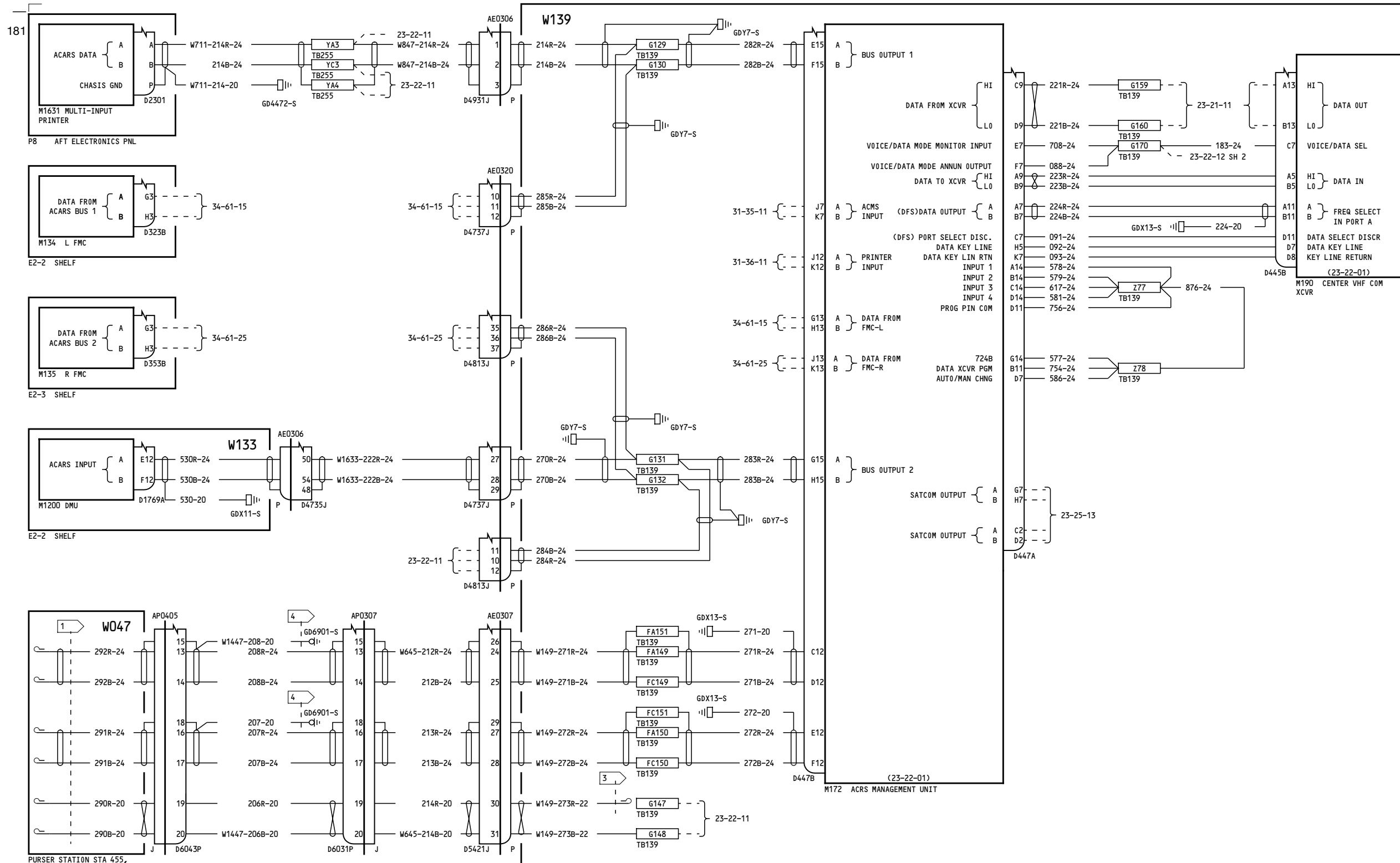

NOTES:
 1 CAP & STOW NEAR STA 467 3 CAP & STOW NEAR TB139 4 MAX LENGTH OF GND WIRES NOT TO EXCEED 18 INCHES

156-157, 166

ACARS, DFDU, FLIGHT MANAGEMENT COMPUTER INTERFACE

D280T132

23-22-12

Page 5A
Sheet 1
Jan 21/2005

Incorporates
MTO-230607

23-22-12

Page 5A
Sheet 1
Jan 21/2005

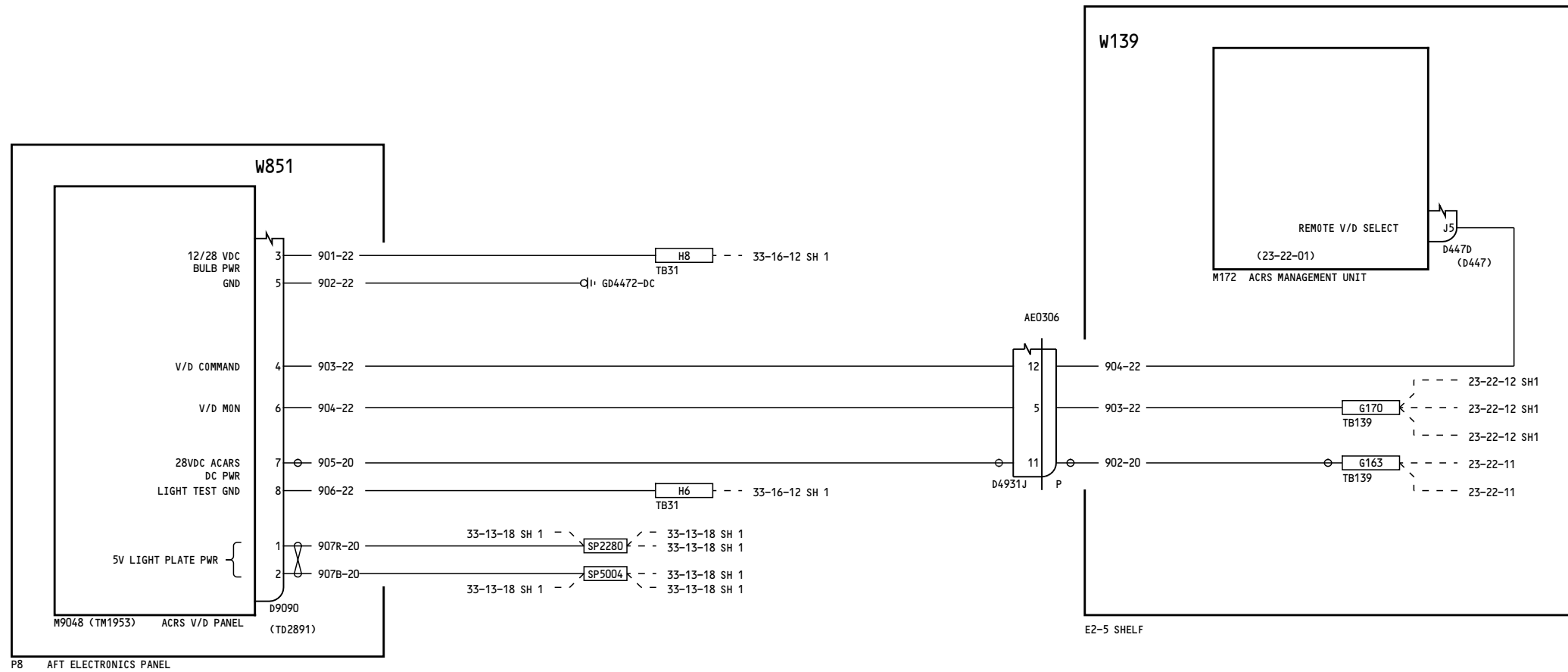

156-157, 166

**ACARS, DFDIU, FLIGHT
MANAGEMENT COMPUTER
INTERFACE**

D280T132

23-22-12

Page 5A
Sheet 2
Jan 21/2005

Incorporates
MTO-230607

23-22-12

Page 5A
Sheet 2
Jan 21/2005

182

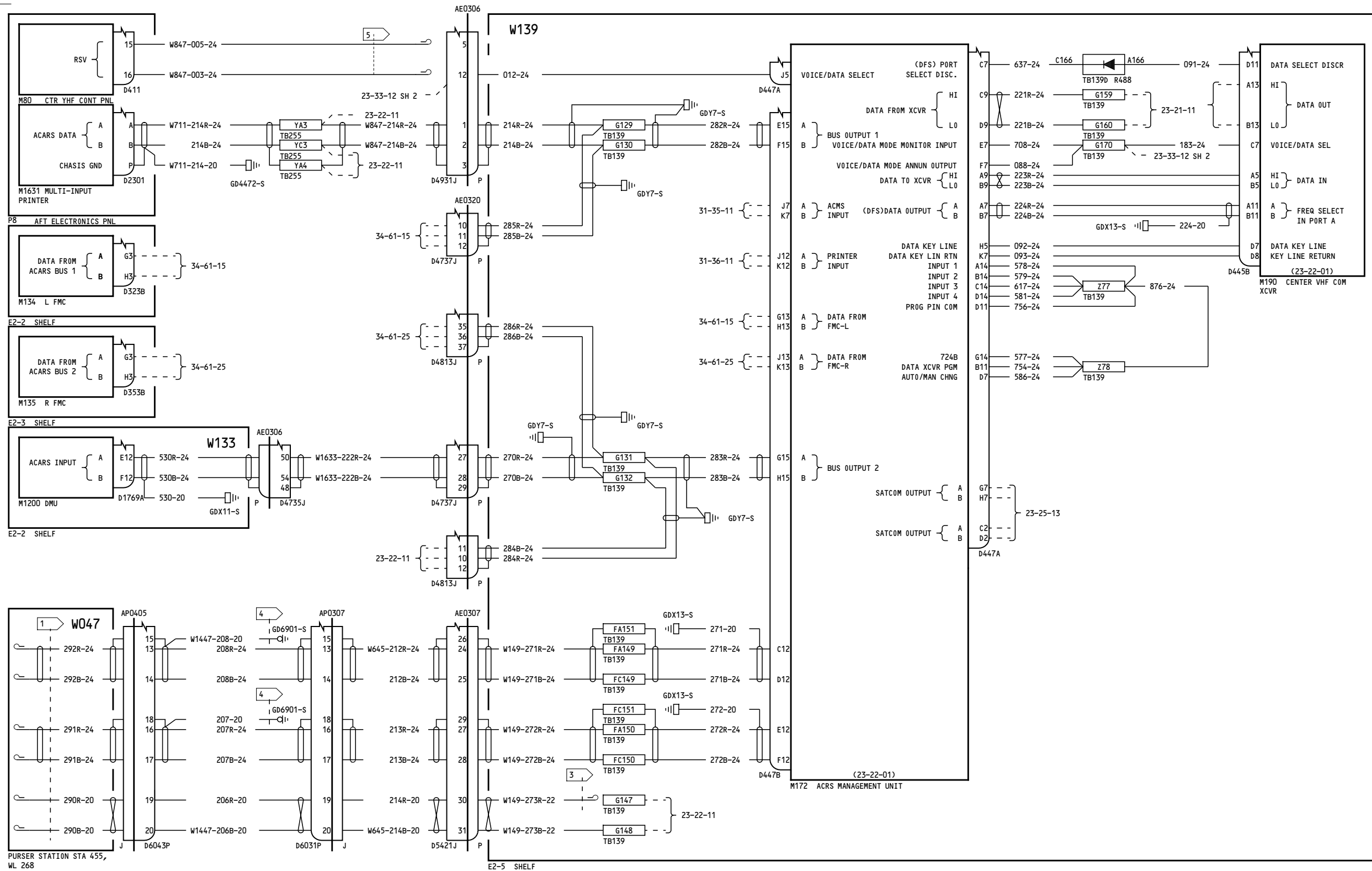

NOTES:
 1 CAP & STOW NEAR STA 467 2 CAP & STOW NEAR TB139 3 MAX LENGTH OF GND WIRES NOT TO EXCEED 18 INCHES 4 CAP AND STOW NEAR D4931J

167

ACARS, DFDU, FLIGHT MANAGEMENT COMPUTER INTERFACE

D280T132

23-22-12

Page 6A
 Sheet 1
 Jan 21/2005

Incorporates
 MTO-230607

23-22-12

Page 6A
 Sheet 1
 Jan 21/2005

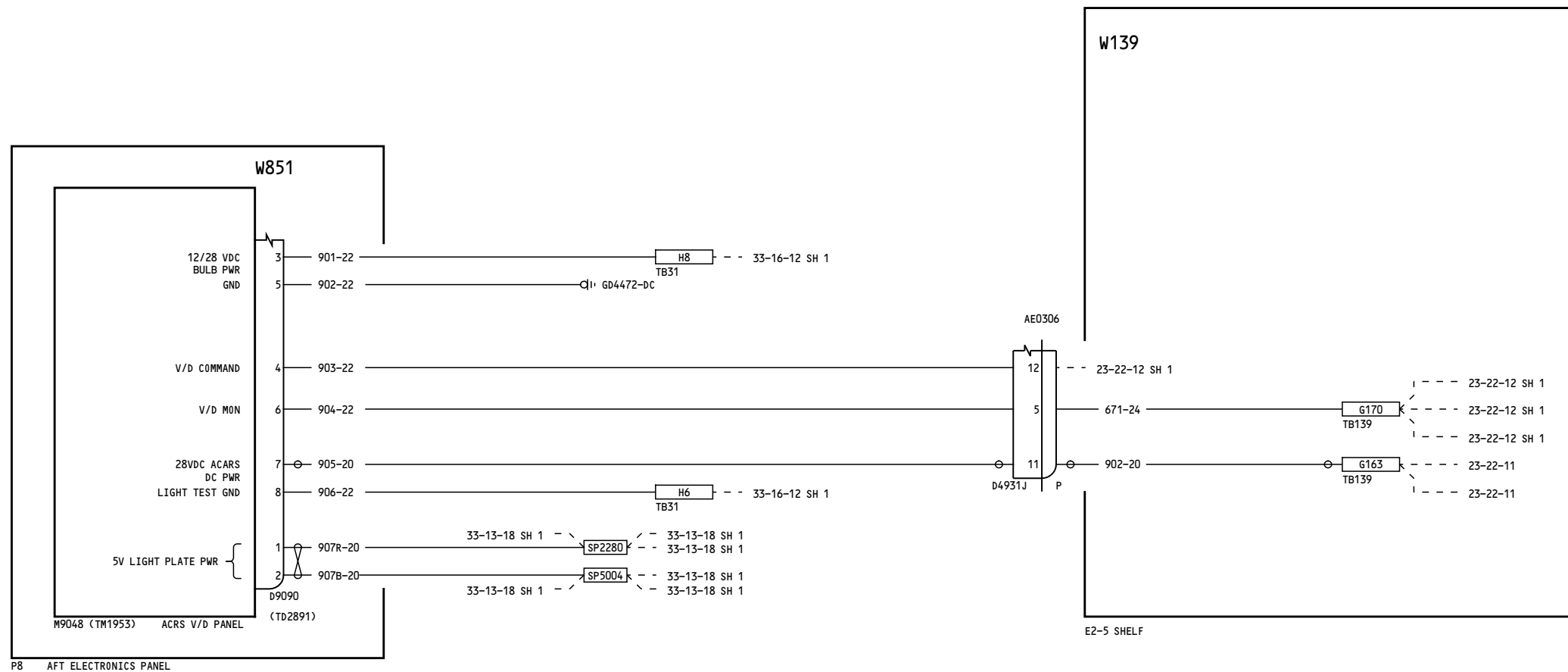

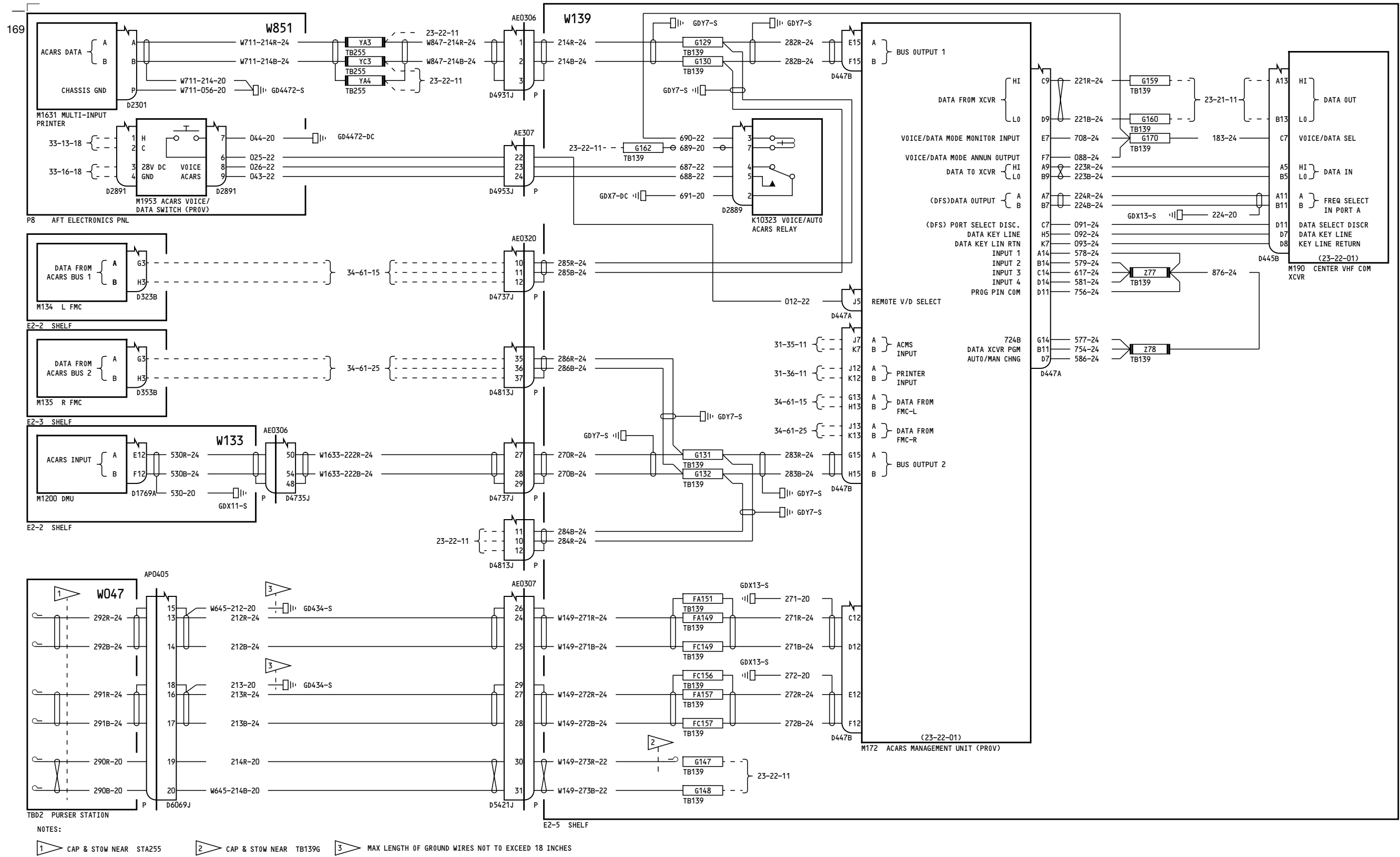

NOTES:

1 CAP & STOW NEAR STA255

2 CAP & STOW NEAR TB139G

3 MAX LENGTH OF GROUND WIRES NOT TO EXCEED 18 INCHES

275-276

ACARS, DFDU, FLIGHT MANAGEMENT COMPUTER INTERFACE

D280T132

23-22-12

Page 7A

Jan 21/2005

Incorporates
MTO-230589

23-22-12

Page 7A

Jan 21/2005

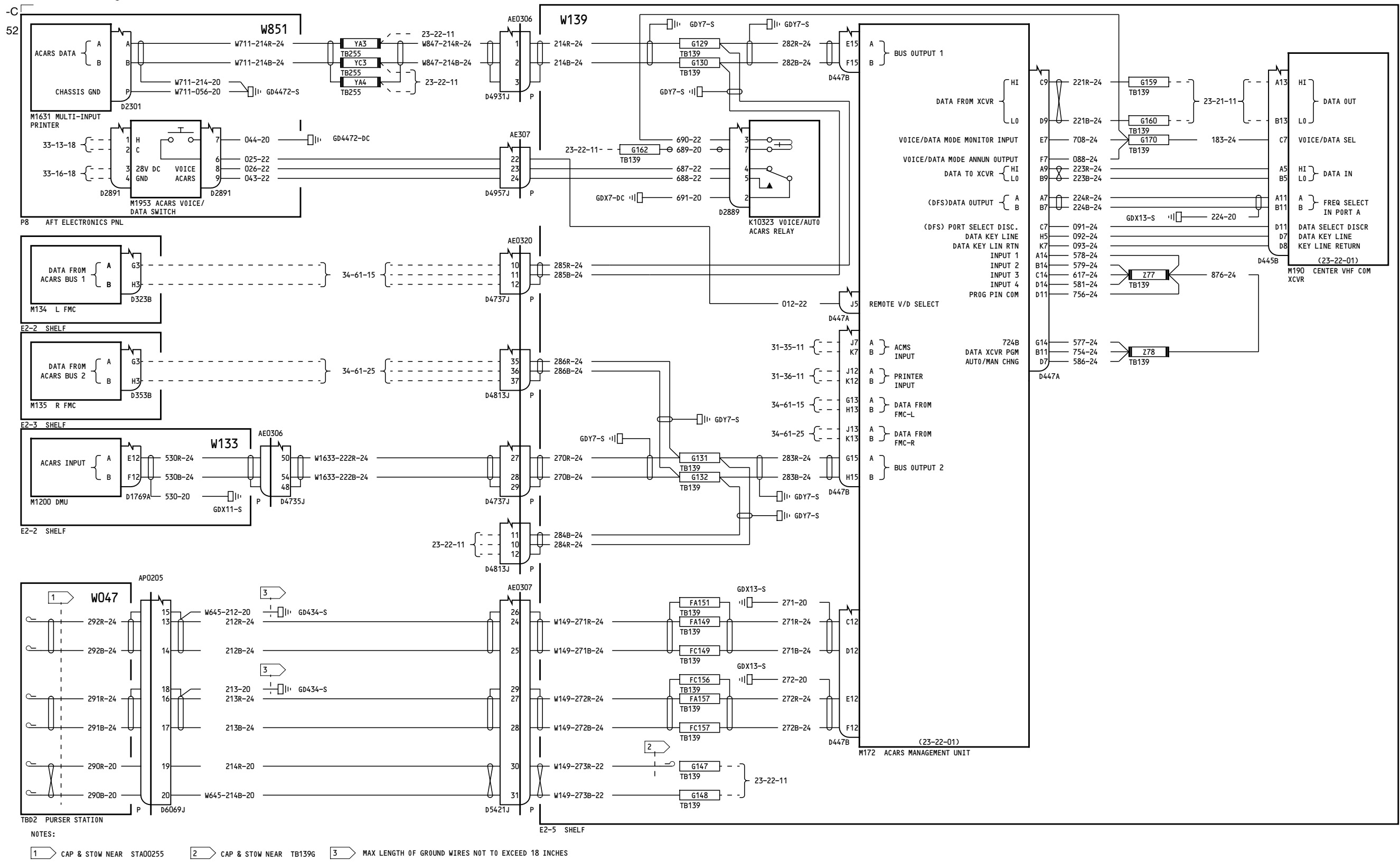

NOTES:
1 CAP & STOW NEAR STA00255
2 CAP & STOW NEAR TB139G
3 MAX LENGTH OF GROUND WIRES NOT TO EXCEED 18 INCHES

277-278

ACARS, DFDU, FLIGHT MANAGEMENT COMPUTER INTERFACE
D280T132

23-22-12
Page 8A
Jan 21/2005

Incorporates
MTO-230589

23-22-12
Page 8A
Jan 21/2005

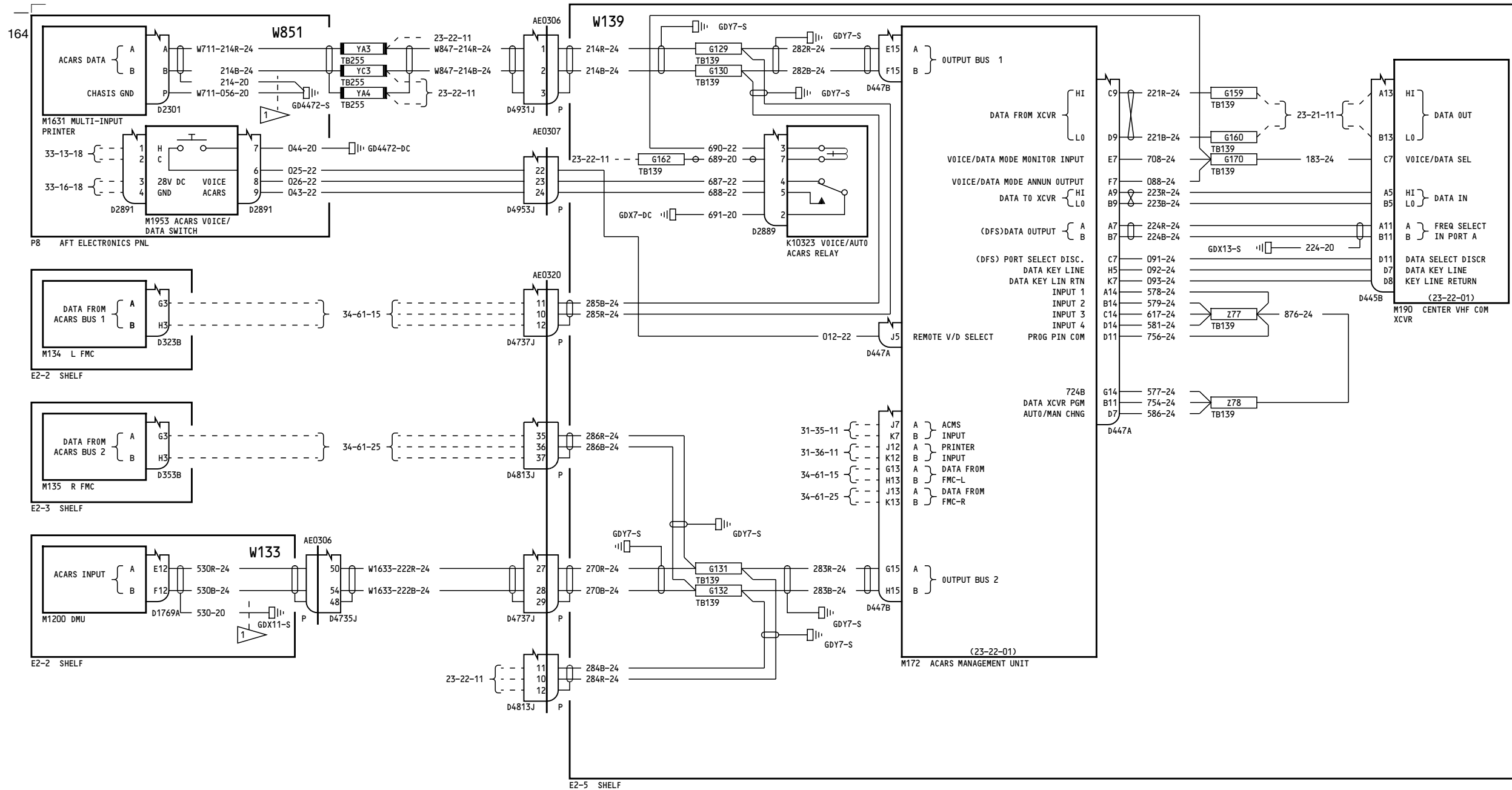

NOTES:
1 MAX LENGTH OF GND WIRES NOT TO EXCEED 18 INCHES

280

ACARS, DFDU, FLIGHT MANAGEMENT COMPUTER INTERFACE

D280T132

23-22-12

Page 9A

Jan 21/2005

Incorporates
MTO-230589

23-22-12

Page 9A

Jan 21/2005

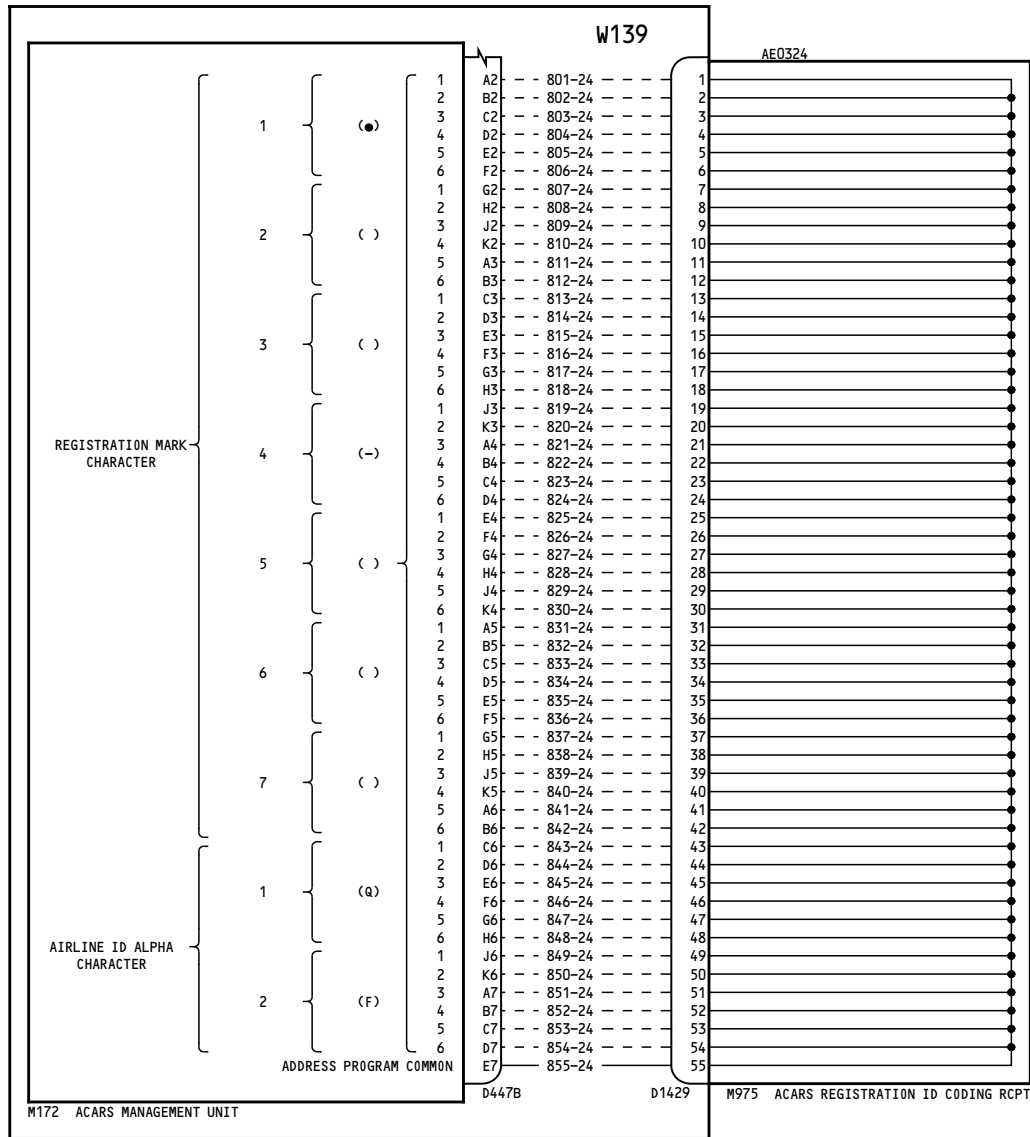

WIRING CHART

AIRPLANE	CODE	REGISTRATION MARK CHARACTER																												AIRPLANE ID ALPHA CHARACTER																															
		1							2							3							4							5							6							7							1		2								
WIRE NO.		801-24	802-24	803-24	804-24	805-24	806-24	807-24	808-24	809-24	810-24	811-24	812-24	813-24	814-24	815-24	816-24	817-24	818-24	819-24	820-24	821-24	822-24	823-24	824-24	825-24	826-24	827-24	828-24	829-24	830-24	831-24	832-24	833-24	834-24	835-24	836-24	837-24	838-24	839-24	840-24	841-24	842-24	843-24	844-24	845-24	846-24	847-24	848-24	849-24	850-24	851-24	852-24	853-24	854-24						
VN151	.LN-RCH SK	0	1	1	1	0	1	0	0	1	1	0	0	0	1	1	1	0	0	1	0	1	1	0	1	0	1	0	0	1	0	1	1	0	0	0	0	0	0	0	1	0	0	1	1	0	0	1	0	1	1	0	1	0	0						
VN153	.OY-KDH SK	0	1	1	1	0	1	1	1	1	1	0	0	1	0	0	1	1	0	1	0	1	1	0	1	1	1	0	1	0	0	0	0	1	0	0	0	0	0	0	1	0	0	1	1	0	0	1	0	1	1	0	1	0	0						
VN154	.LN-RCG SK	0	1	1	1	0	1	0	0	1	1	0	0	0	1	1	1	0	0	1	0	1	1	0	1	0	1	0	0	1	0	1	1	0	0	0	0	1	1	1	0	0	0	1	1	0	0	1	0	1	1	0	1	0	0						
VN155	.LN-RCI SK	0	1	1	1	0	1	0	0	1	1	0	0	0	1	1	1	0	0	1	0	1	1	0	1	0	1	0	0	1	0	1	1	0	0	0	0	1	0	0	1	0	0	1	1	0	0	1	0	1	1	0	1	0	0						
VN156	.OY-KDL SK	0	1	1	1	0	1	1	1	1	1	0	0	1	0	0	1	1	0	1	0	1	1	0	1	1	1	0	1	0	0	0	0	1	0	0	0	0	0	1	1	0	0	1	1	0	0	1	0	0	1	1	0	1	0	0					
VN157	.LN-RCK SK	0	1	1	1	0	1	0	0	1	1	0	0	0	1	1	1	0	0	1	0	1	1	0	1	0	1	0	0	1	0	1	1	0	0	0	0	1	1	0	1	0	0	1	1	0	0	1	0	1	1	0	1	0	0						
VN158	.LN-RCL SK	0	1	1	1	0	1	0	0	1	1	0	0	0	1	1	1	0	0	1	0	1	1	0	1	0	1	0	0	1	0	1	1	0	0	0	0	0	0	1	1	0	0	1	1	0	0	1	0	1	1	0	1	0	0						
VN163	.LN-RCE SK	0	1	1	1	0	1	0	0	1	1	0	0	0	1	1	1	0	0	1	0	1	1	0	1	0	1	0	0	1	0	1	1	0	0	0	0	1	0	1	0	0	0	1	1	0	0	1	0	1	1	0	1	0	0						
VN164	.PH-AHX OR	0	1	1	1	0	1	0	0	0	0	1	0	0	0	0	1	0	0	1	0	1	1	0	1	1	0	0	0	0	0	0	0	0	1	0	0	0	0	0	1	1	0	1	1	1	0	0	0	0	1	0	0	1	0	1	1	0	0	1	0
VN165	.OY-KDN SK	0	1	1	1	0	1	1	1	1	1	0	0	1	0	0	1	1	0	1	0	1	1	0	1	1	1	0	1	0	0	0	0	1	0	0	0	0	1	1	1	0	0	1	1	0	0	1	0	1	1	0	1	0	0						
VN167	.OY-KDM SK	0	1	1	1	0	1	1	1	1	1	0	0	1	0	0	1	1	0	1	0	1	1	0	1	1	1	0	1	0	0	0	0	1	0	0	0	1	0	1	1	0	0	1	1	0	0	1	0	1	1	0	1	0	0						
VN168	.SE-DOC SK	0	1	1	1	0	1	1	1	0	0	1	0	1	0	1	0	0	0	1	0	1	1	0	1	0	0	1	0	0	0	1	1	1	1	0	0	1	1	0	0	0	0	1	1	0	0	1	0	1	1	0	1	0	0						

1

NOTES:

1 SEE WIRING CHART FOR HOOK UP INFORMATION OF DOTTED LINES
 LOGIC "1" - INSTALL THE WIRES
 LOGIC "0" - DO NOT INSTALL THE WIRES

150, 152-164, 166-167	ACARS CODING
	D280T132

23-22-13

Page 1A

Jun 28/2006

Incorporates
 MTO-230607
 MTO-230762

23-22-13

Page 1A

Jun 28/2006

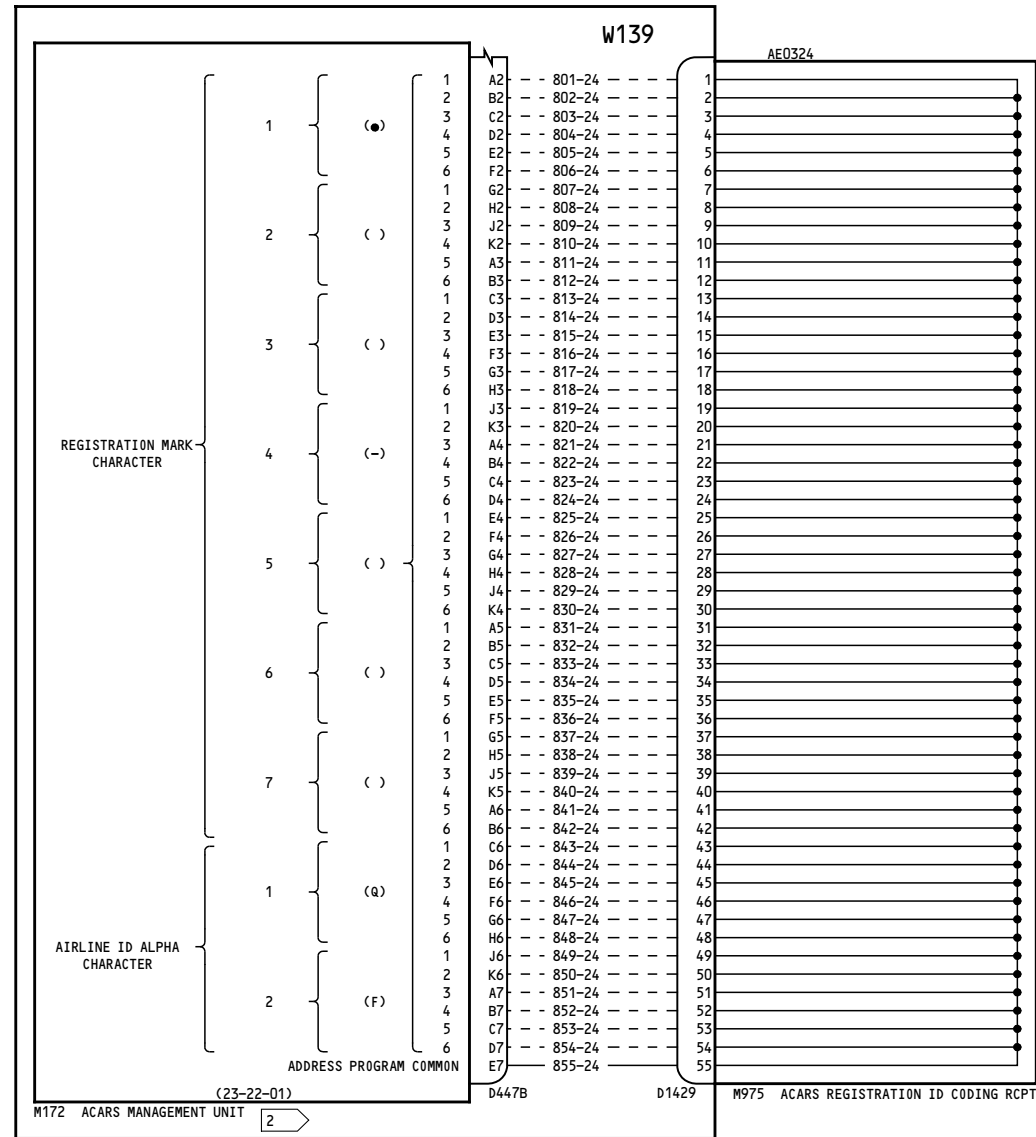

WIRING CHART

AIRPLANE	CODE	REGISTRATION MARK CHARACTER																												AIRPLANE ID ALPHA CHARACTER																									
		1							2							3							4							5							6							7							1		2		
		801-24	802-24	803-24	804-24	805-24	806-24	807-24	808-24	809-24	810-24	811-24	812-24	813-24	814-24	815-24	816-24	817-24	818-24	819-24	820-24	821-24	822-24	823-24	824-24	825-24	826-24	827-24	828-24	829-24	830-24	831-24	832-24	833-24	834-24	835-24	836-24	837-24	838-24	839-24	840-24	841-24	842-24	843-24	844-24	845-24	846-24	847-24	848-24	849-24	850-24	851-24	852-24	853-24	854-24
VN151	.LN-RCH SK	0	1	1	1	0	1	0	0	1	1	0	0	0	1	1	1	0	0	1	0	1	1	0	1	0	1	0	0	1	0	1	1	0	0	0	0	0	0	0	1	0	0	1	1	0	0	1	0	1	1	0	1	0	0

NOTES:

1 SEE WIRING CHART FOR HOOK UP INFORMATION OF DOTTED LINES
 LOGIC "0" - INSTALL THE WIRES
 LOGIC "1" - DO NOT INSTALL THE WIRES

2 M172 PROVISIONAL FOR VN151-VN167 (150-274)

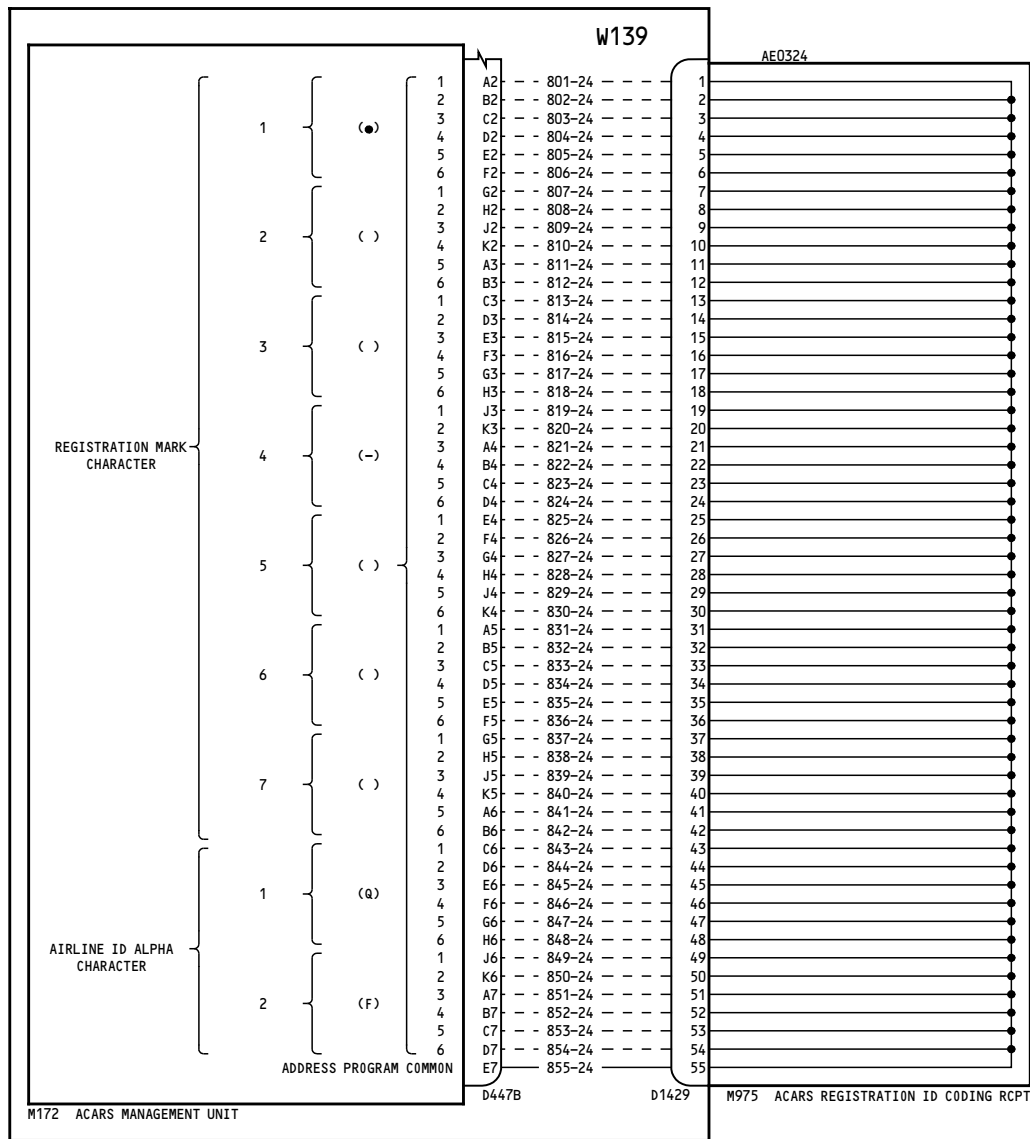

WIRING CHART

WIRE NO	REGISTRATION MARK CHARACTER																												AIRPLANE ID ALPHA CHARACTER																										
	1							2							3							4							5							6							7							1		2			
	801-24	802-24	803-24	804-24	805-24	806-24	807-24	808-24	809-24	810-24	811-24	812-24	813-24	814-24	815-24	816-24	817-24	818-24	819-24	820-24	821-24	822-24	823-24	824-24	825-24	826-24	827-24	828-24	829-24	830-24	831-24	832-24	833-24	834-24	835-24	836-24	837-24	838-24	839-24	840-24	841-24	842-24	843-24	844-24	845-24	846-24	847-24	848-24	849-24	850-24	851-24	852-24	853-24	854-24	
AIRPLANE	CODE																																																						
VN151	.LN-RCF SK																																																						
	0	1	1	1	0	1	0	0	1	1	0	0	0	1	1	1	0	0	1	0	1	1	0	1	0	1	0	0	1	0	1	1	0	0	0	0	0	1	1	0	0	0	1	1	0	0	1	0	1	1	0	0	1	0	0

NOTES:

1 SEE WIRING CHART FOR HOOK UP INFORMATION OF DOTTED LINES
 LOGIC "0" - INSTALL THE WIRES
 LOGIC "1" - DO NOT INSTALL THE WIRES

-C
19

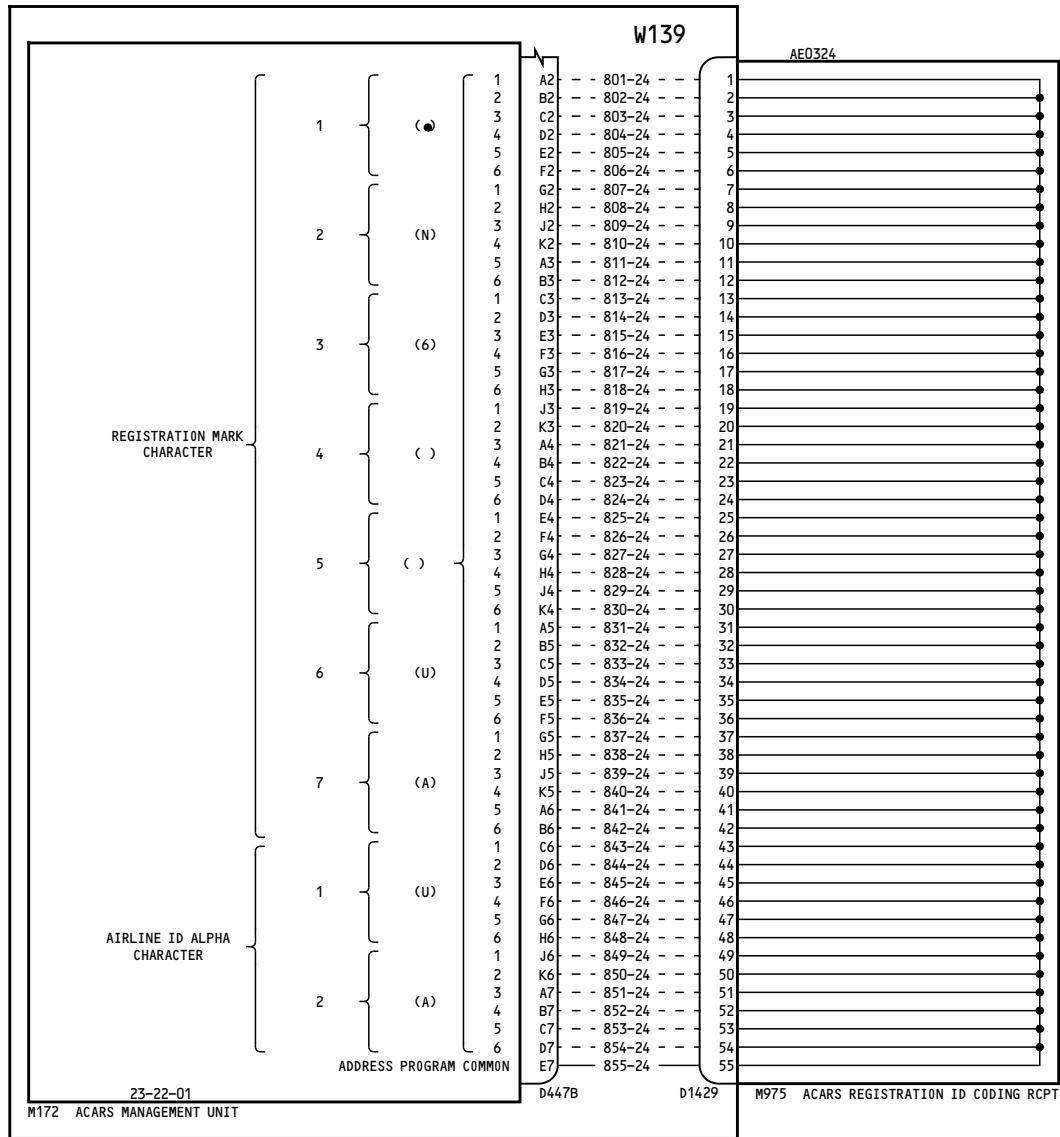

E2-5 SHELF



NOTES:
1 SEE WIRING CHART FOR HOOK UP INFORMATION OF DOTTED LINES
LOGIC "0" - INSTALL THE WIRES
LOGIC "1" - DO NOT INSTALL THE WIRES

WIRING CHART

WIRE NO.	REGISTRATION MARK CHARACTER							AIRLINE ID ALPHA CHARACTER	
	1	2	3	4	5	6	7	1	2
801-24	0	1	1	1	0	1			
802-24	0	1	1	1	0	1			
803-24	0	1	1	1	0	1			
804-24	0	1	1	1	0	1			
805-24	0	1	1	1	0	1			
806-24	0	1	1	1	0	1			
807-24	0	1	1	1	0	1			
808-24	0	1	1	1	0	1			
809-24	0	1	1	1	0	1			
810-24	0	1	1	1	0	1			
811-24	0	1	1	1	0	1			
812-24	0	1	1	1	0	1			
813-24	0	1	1	1	0	1			
814-24	0	1	1	1	0	1			
815-24	0	1	1	1	0	1			
816-24	0	1	1	1	0	1			
817-24	0	1	1	1	0	1			
818-24	0	1	1	1	0	1			
819-24	0	1	1	1	0	1			
820-24	0	1	1	1	0	1			
821-24	0	1	1	1	0	1			
822-24	0	1	1	1	0	1			
823-24	0	1	1	1	0	1			
824-24	0	1	1	1	0	1			
825-24	0	1	1	1	0	1			
826-24	0	1	1	1	0	1			
827-24	0	1	1	1	0	1			
828-24	0	1	1	1	0	1			
829-24	0	1	1	1	0	1			
830-24	0	1	1	1	0	1			
831-24	0	1	1	1	0	1			
832-24	0	1	1	1	0	1			
833-24	0	1	1	1	0	1			
834-24	0	1	1	1	0	1			
835-24	0	1	1	1	0	1			
836-24	0	1	1	1	0	1			
837-24	0	1	1	1	0	1			
838-24	0	1	1	1	0	1			
839-24	0	1	1	1	0	1			
840-24	0	1	1	1	0	1			
841-24	0	1	1	1	0	1			
842-24	0	1	1	1	0	1			
843-24	0	1	1	1	0	1			
844-24	0	1	1	1	0	1			
845-24	0	1	1	1	0	1			
846-24	0	1	1	1	0	1			
847-24	0	1	1	1	0	1			
848-24	0	1	1	1	0	1			
849-24	0	1	1	1	0	1			
850-24	0	1	1	1	0	1			
851-24	0	1	1	1	0	1			
852-24	0	1	1	1	0	1			
853-24	0	1	1	1	0	1			
854-24	0	1	1	1	0	1			
855-24	0	1	1	1	0	1			

275-278

ACARS CODING

D280T132

23-22-13

Page 4

Jan 21/2005

23-22-13

Page 4

Jan 21/2005

-A
31

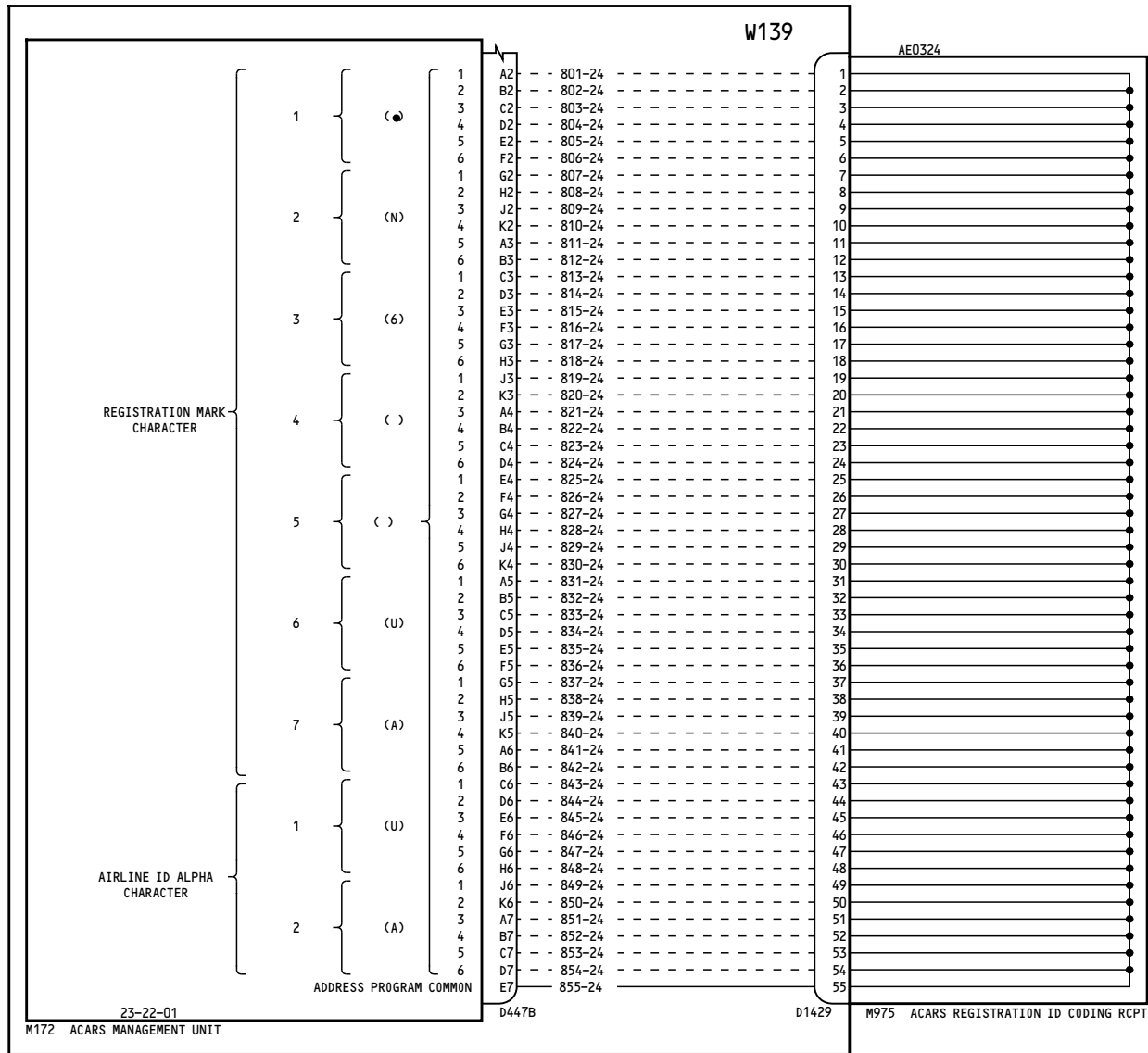

WIRING CHART

WIRE NO.	REGISTRATION MARK CHARACTER							AIRLINE ID ALPHA CHARACTER	
	1	2	3	4	5	6	7	1	2
801-24	0	1	1	1	0	1	0	0	0
802-24	0	1	1	1	0	1	0	0	0
803-24	0	1	1	1	0	1	0	0	0
804-24	0	1	1	1	0	1	0	0	0
805-24	0	1	1	1	0	1	0	0	0
806-24	0	1	1	1	0	1	0	0	0
807-24	0	1	1	1	0	1	0	0	0
808-24	0	1	1	1	0	1	0	0	0
809-24	0	1	1	1	0	1	0	0	0
810-24	0	1	1	1	0	1	0	0	0
811-24	0	1	1	1	0	1	0	0	0
812-24	0	1	1	1	0	1	0	0	0
813-24	0	1	1	1	0	1	0	0	0
814-24	0	1	1	1	0	1	0	0	0
815-24	0	1	1	1	0	1	0	0	0
816-24	0	1	1	1	0	1	0	0	0
817-24	0	1	1	1	0	1	0	0	0
818-24	0	1	1	1	0	1	0	0	0
819-24	0	1	1	1	0	1	0	0	0
820-24	0	1	1	1	0	1	0	0	0
821-24	0	1	1	1	0	1	0	0	0
822-24	0	1	1	1	0	1	0	0	0
823-24	0	1	1	1	0	1	0	0	0
824-24	0	1	1	1	0	1	0	0	0
825-24	0	1	1	1	0	1	0	0	0
826-24	0	1	1	1	0	1	0	0	0
827-24	0	1	1	1	0	1	0	0	0
828-24	0	1	1	1	0	1	0	0	0
829-24	0	1	1	1	0	1	0	0	0
830-24	0	1	1	1	0	1	0	0	0
831-24	0	1	1	1	0	1	0	0	0
832-24	0	1	1	1	0	1	0	0	0
833-24	0	1	1	1	0	1	0	0	0
834-24	0	1	1	1	0	1	0	0	0
835-24	0	1	1	1	0	1	0	0	0
836-24	0	1	1	1	0	1	0	0	0
837-24	0	1	1	1	0	1	0	0	0
838-24	0	1	1	1	0	1	0	0	0
839-24	0	1	1	1	0	1	0	0	0
840-24	0	1	1	1	0	1	0	0	0
841-24	0	1	1	1	0	1	0	0	0
842-24	0	1	1	1	0	1	0	0	0
843-24	0	1	1	1	0	1	0	0	0
844-24	0	1	1	1	0	1	0	0	0
845-24	0	1	1	1	0	1	0	0	0
846-24	0	1	1	1	0	1	0	0	0
847-24	0	1	1	1	0	1	0	0	0
848-24	0	1	1	1	0	1	0	0	0
849-24	0	1	1	1	0	1	0	0	0
850-24	0	1	1	1	0	1	0	0	0
851-24	0	1	1	1	0	1	0	0	0
852-24	0	1	1	1	0	1	0	0	0
853-24	0	1	1	1	0	1	0	0	0
854-24	0	1	1	1	0	1	0	0	0
855-24	0	1	1	1	0	1	0	0	0

1

NOTES:

1 SEE WIRING CHART FOR HOOK UP INFORMATION OF DOTTED LINES
 LOGIC "0" - INSTALL THE WIRES
 LOGIC "1" - DO NOT INSTALL THE WIRES

280-299	ACARS CODING
	D280T132

23-22-13

Page 5

Jan 21/2005

23-22-13

Page 5

Jan 21/2005



767-200/300 WIRING DIAGRAM MANUAL

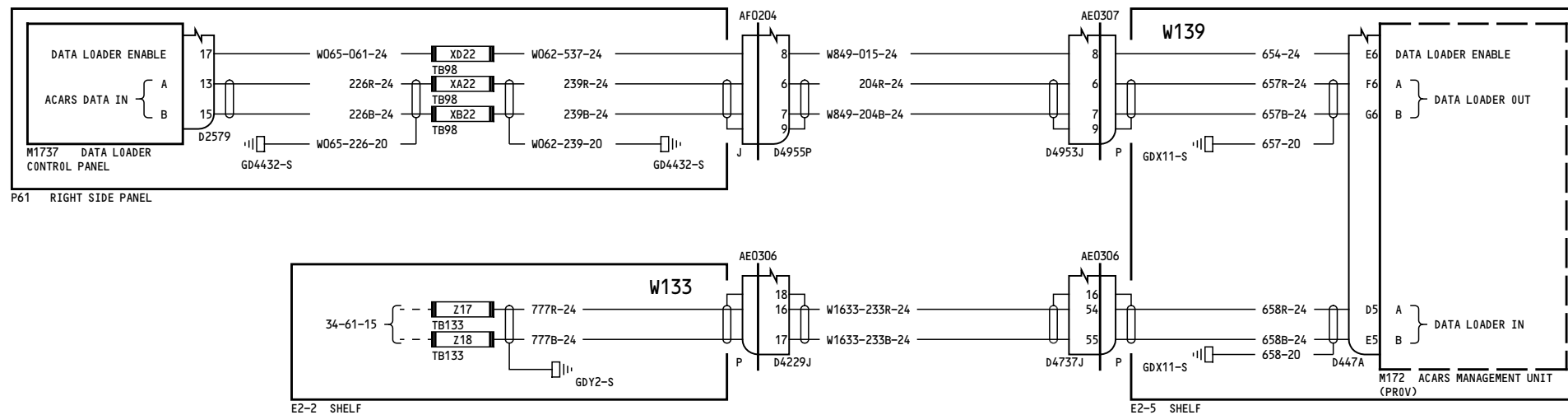

050-099, 155-166, 275-278

**ACARS-
DATA LOADER INTERFACE**

D280T132

23-22-15

Page 1

Jan 21/2005

23-22-15

Page 1

Jan 21/2005

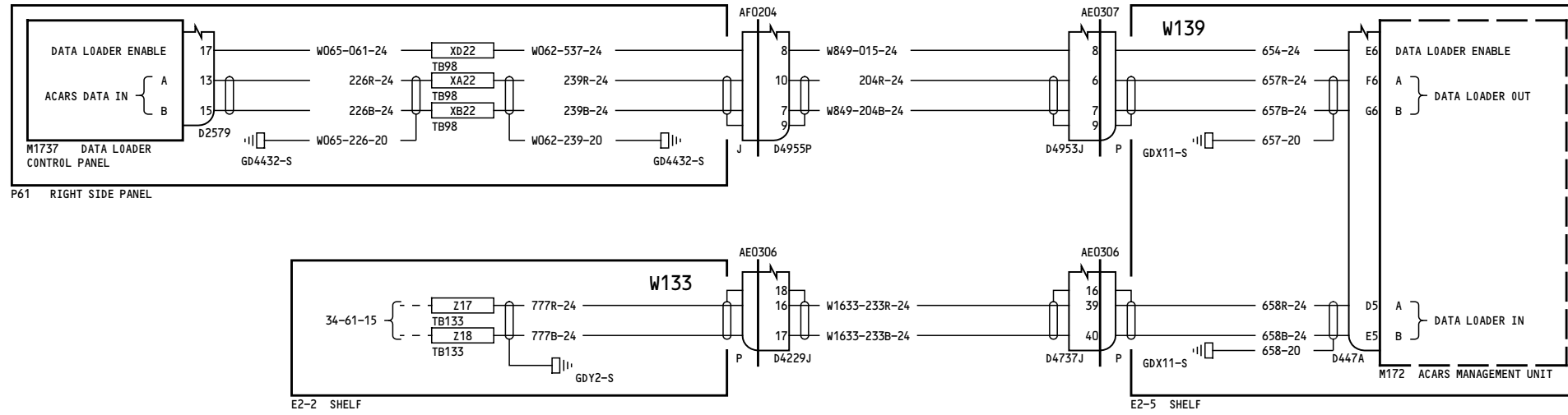

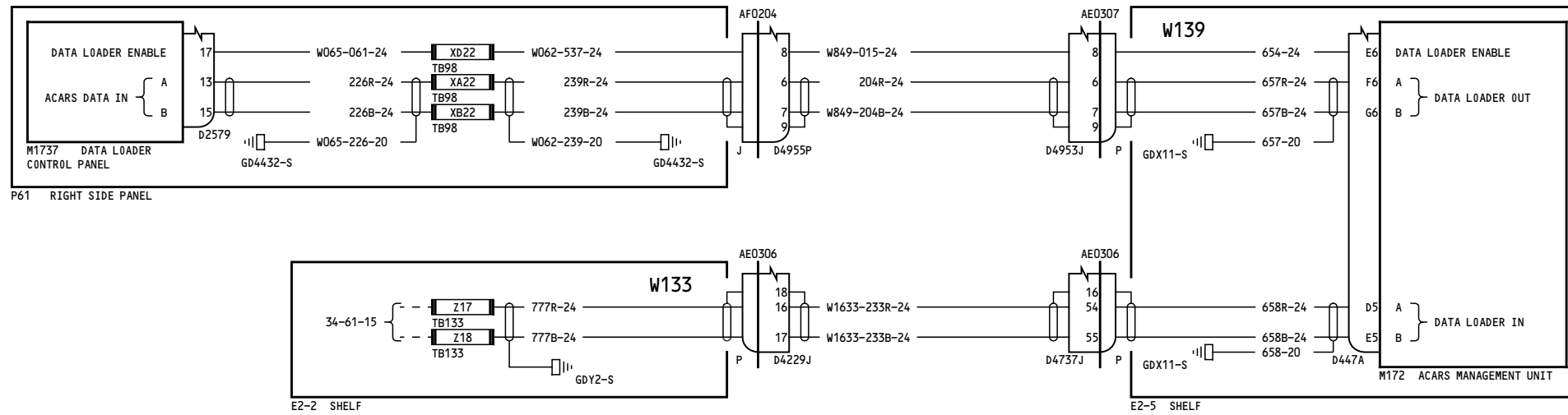

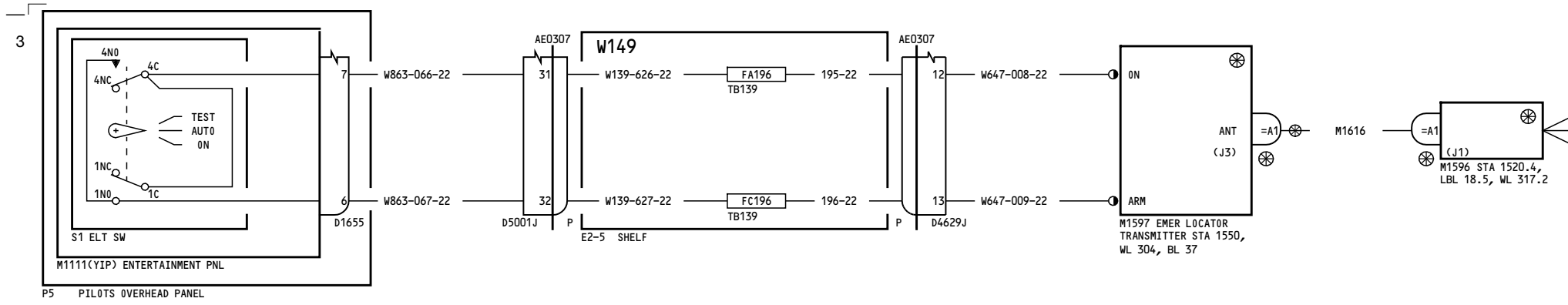

050-099

**EMERGENCY LOCATOR
TRANSMITTER**

D280T132

23-24-11

Page 1

Jan 21/2005

23-24-11

Page 1

Jan 21/2005

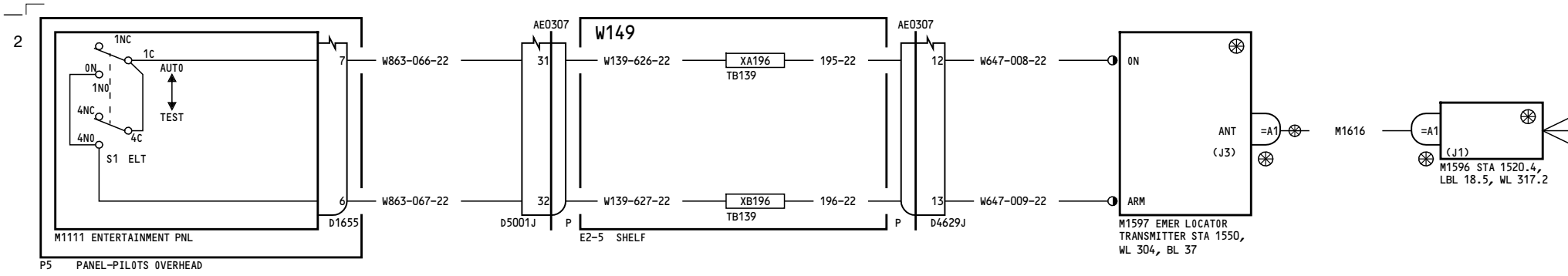



NOTES:
 1 MAXIMUM LENGTH OF GROUND WIRE SHALL NOT EXCEED 18 INCHES

150, 153-155

**SATCOM SYSTEM-
 POWER &
 LGA SUBSYSTEM**

23-25-11

Page 1A

D280T132

Jan 21/2005

Incorporates
 MTO 230593

23-25-11

Page 1A

Jan 21/2005

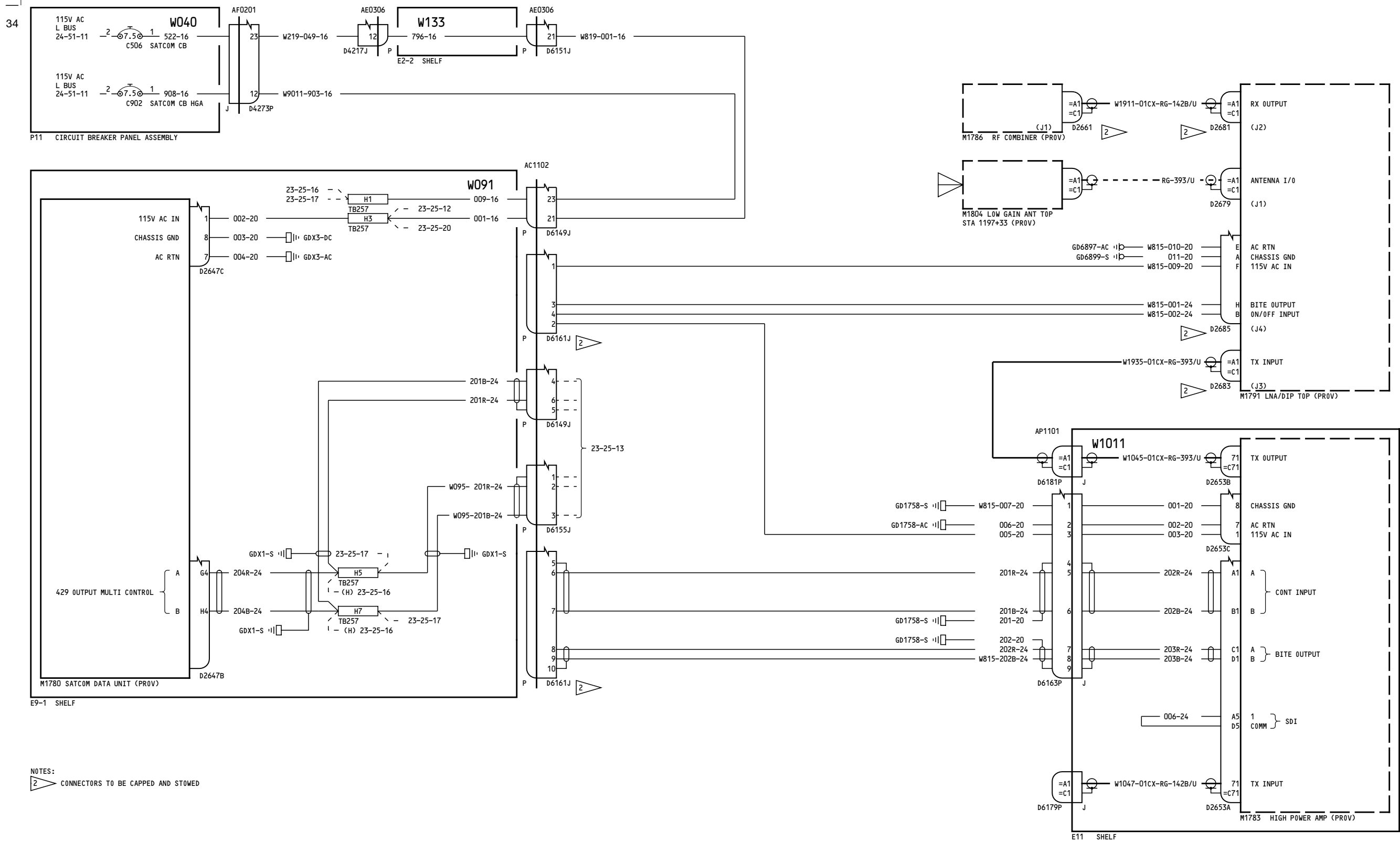

NOTES:
CONNECTORS TO BE CAPPED AND STOWED

156-157, 166

SATCOM SYSTEM-
POWER &
LGA SUBSYSTEM

23-25-11

Page 2A

Jan 21/2005

D280T132

Incorporates
MTO 230591

23-25-11

Page 2A

Jan 21/2005

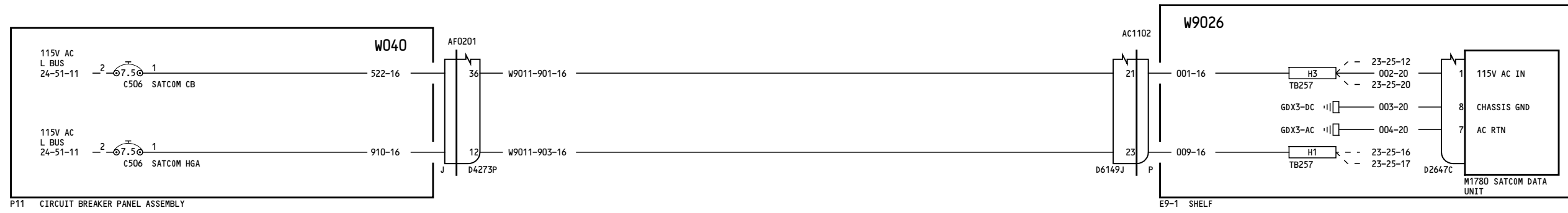

NOTES:
 1 MAXIMUM LENGTH OF GROUND WIRE SHALL NOT EXCEED 18 INCHES

162-165

**SATCOM SYSTEM-
 POWER &
 LGA SUBSYSTEM**

23-25-11

Page 3A

D280T132

Jan 21/2005

Incorporates
 MTO 230592

23-25-11

Page 3A

Jan 21/2005

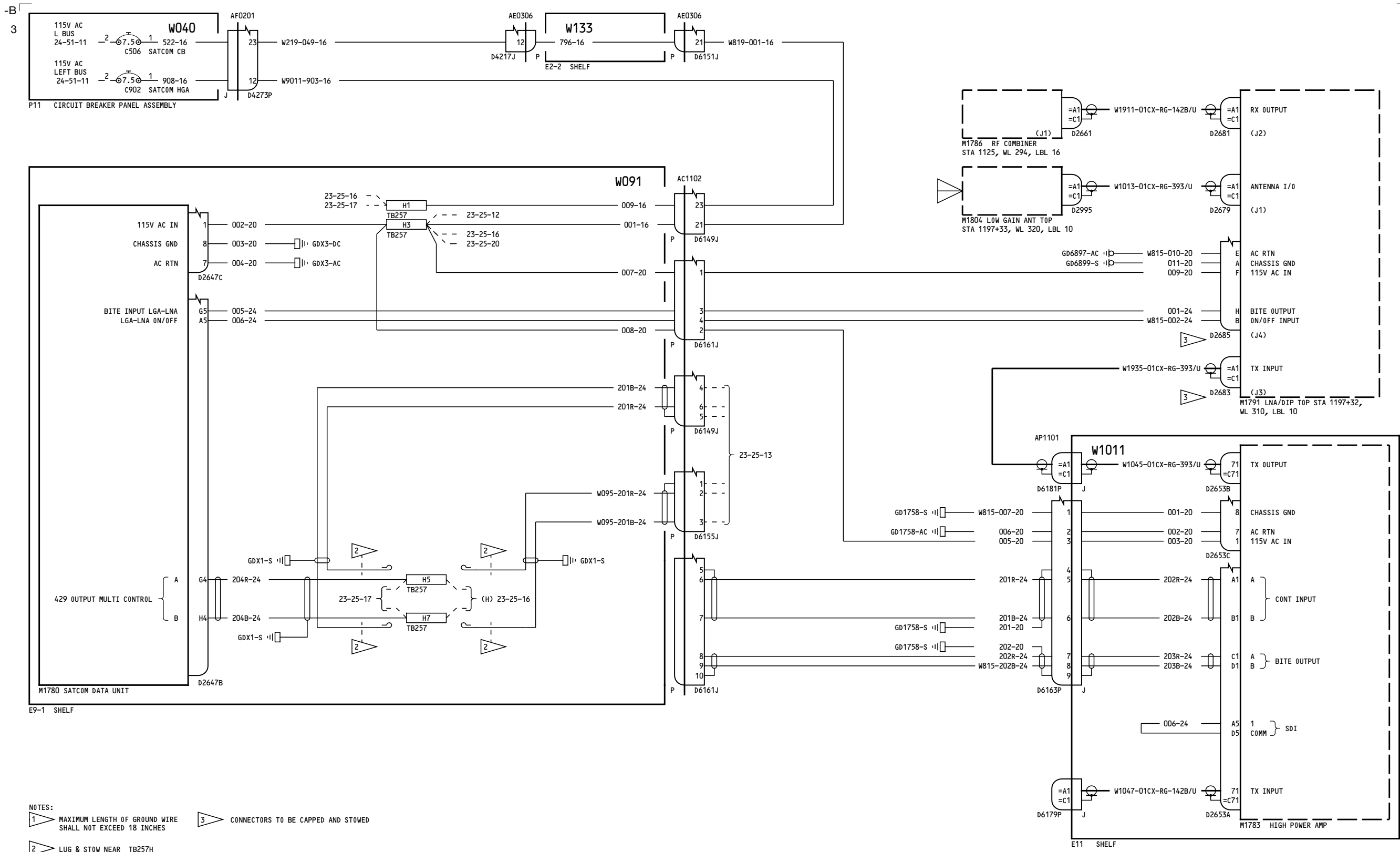

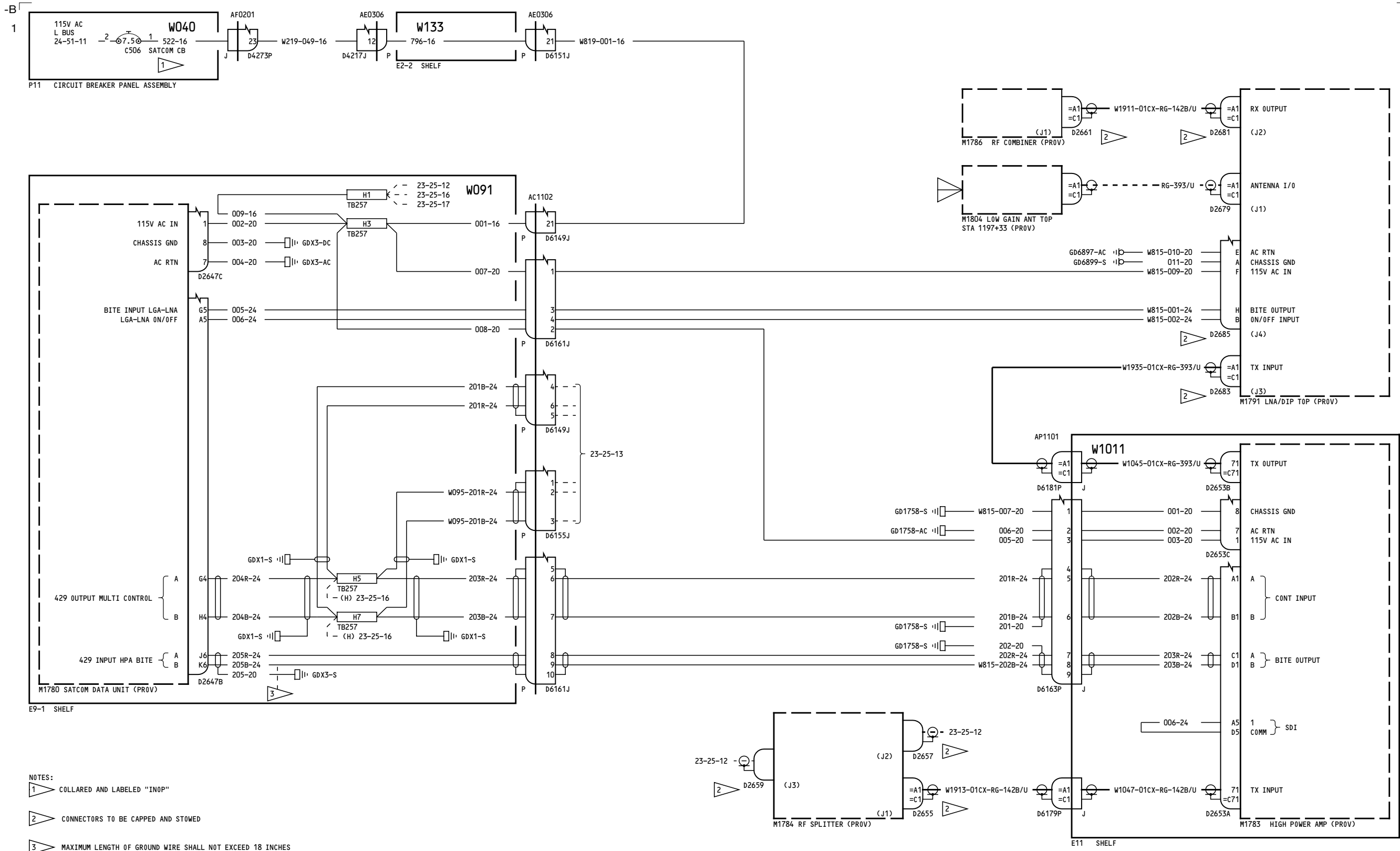

- NOTES:
- 1 COLLARED AND LABELED "INOP"
 - 2 CONNECTORS TO BE CAPPED AND STOWED
 - 3 MAXIMUM LENGTH OF GROUND WIRE SHALL NOT EXCEED 18 INCHES

277-299

SATCOM SYSTEM-
POWER &
LGA SUBSYSTEM

D280T132

23-25-11

Page 5

Jan 21/2005

23-25-11

Page 5

Jan 21/2005

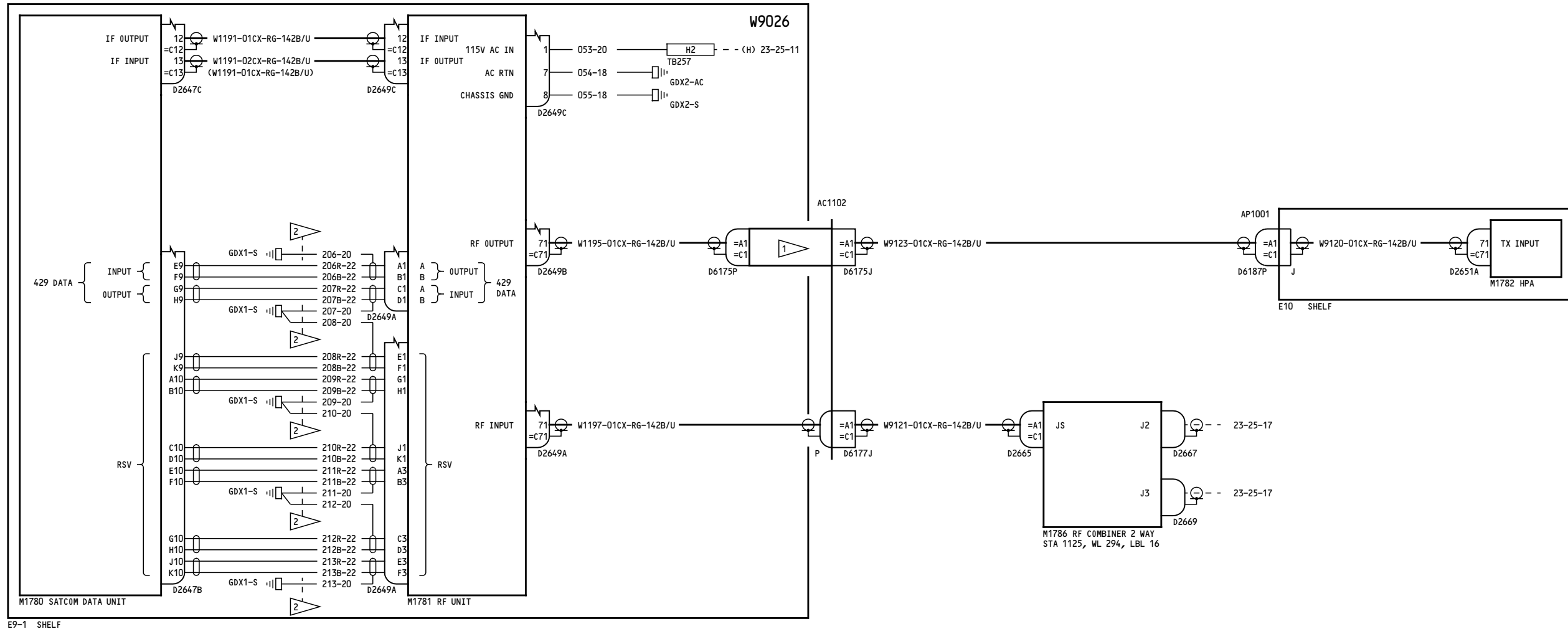

E9-1 SHELF

- NOTES:
- 1 10 DB ATTENUATOR
 - 2 MAXIMUM LENGTH OF GROUND WIRE SHALL NOT EXCEED 18 INCHES

150, 153-155	SATCOM SYSTEM-RADIO FREQUENCY DISTRIBUTION	
	D280T132	

23-25-12

Page 1A

Jan 21/2005

Incorporates
MTO 230593

23-25-12

Page 1A

Jan 21/2005

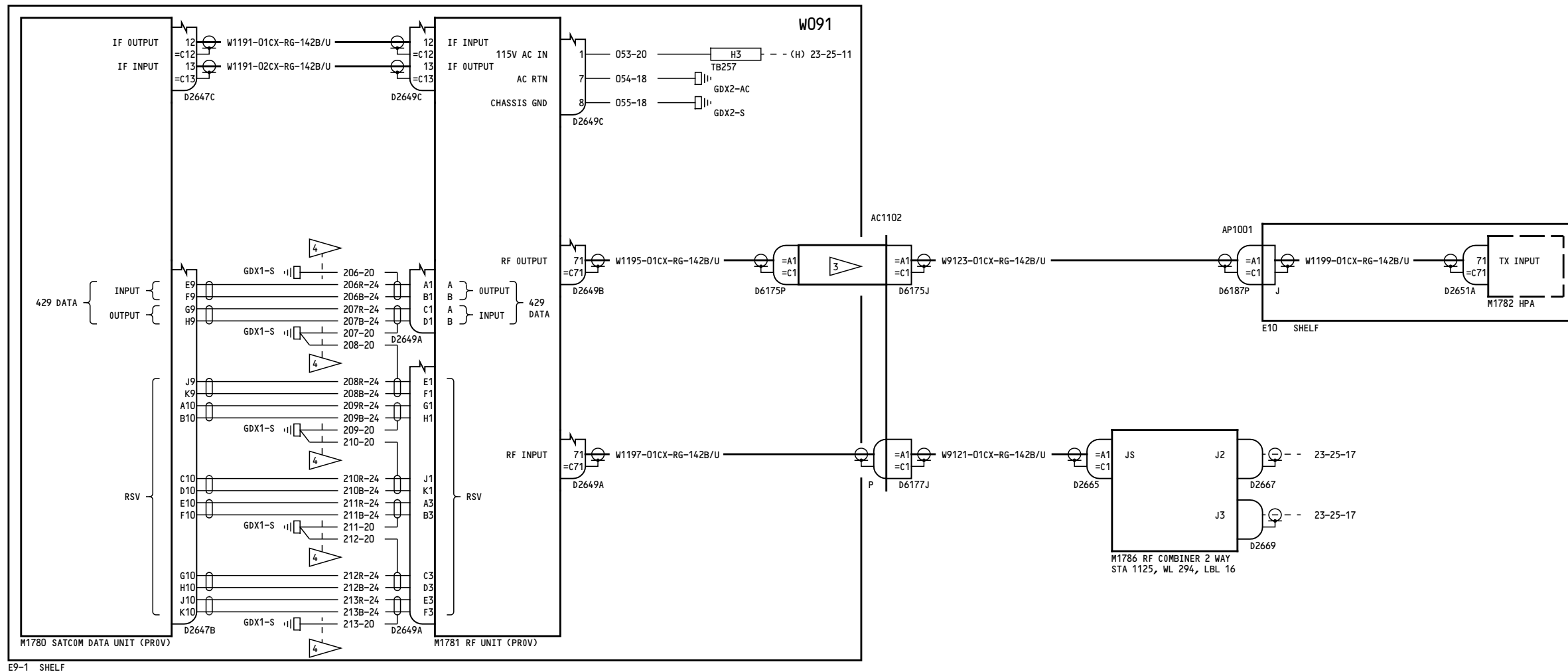

NOTES:
 3 10 DB ATTENUATOR
 4 MAXIMUM LENGTH OF GROUND WIRE SHALL NOT EXCEED 18 INCHES

156-157, 166-167

SATCOM SYSTEM-RADIO FREQUENCY DISTRIBUTION

D280T132

23-25-12

Page 2A
 Jan 21/2005

Incorporates
 MTO 230591

23-25-12

Page 2A
 Jan 21/2005

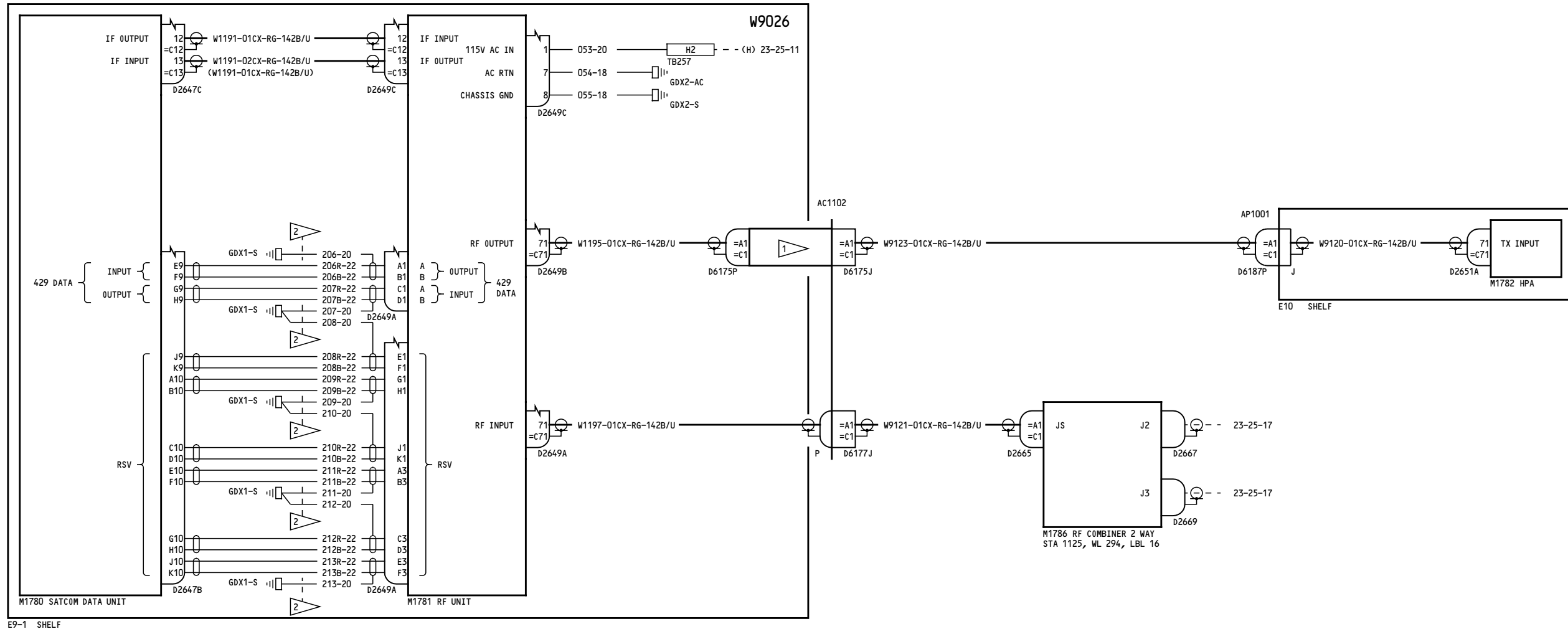

E9-1 SHELF

- NOTES:
- 1 10 DB ATTENUATOR
 - 2 MAXIMUM LENGTH OF GROUND WIRE SHALL NOT EXCEED 18 INCHES

162-165	SATCOM SYSTEM- RADIO FREQUENCY DISTRIBUTION	
	D280T132	

23-25-12

Page 3A

Jan 21/2005

Incorporates
MTO 230592

23-25-12

Page 3A

Jan 21/2005

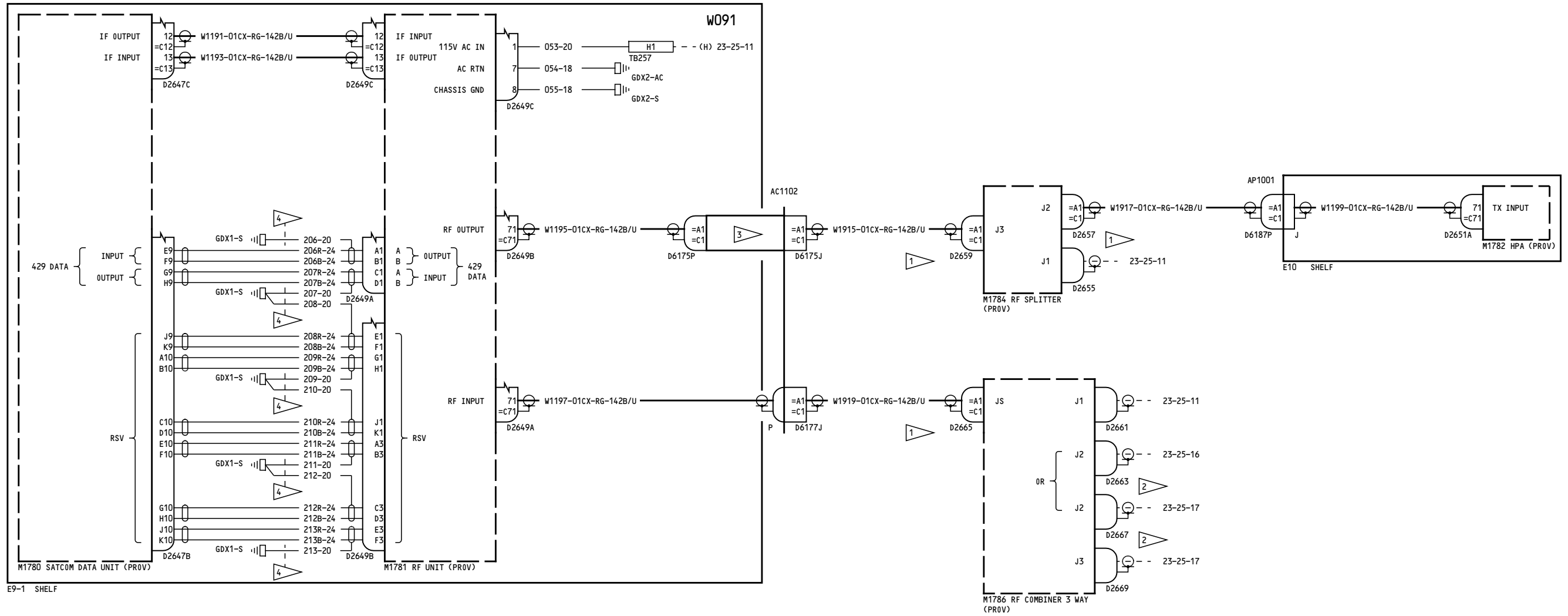

- NOTES:
- 1 CONNECTORS CAPPED & STOWED
 - 2 CONNECTORS CAPPED & STOWED UNTIL THE CHOSEN EQUIPMENT IS INSTALLED, WHEN EITHER D2663 OR D2667 AND D2669 WILL BE USED
 - 3 10 DB ATTENUATOR
 - 4 MAXIMUM LENGTH OF GROUND WIRE SHALL NOT EXCEED 18 INCHES

277-299	SATCOM SYSTEM- RADIO FREQUENCY DISTRIBUTION
	23-25-12 Page 4 Jan 21/2005
	D280T132

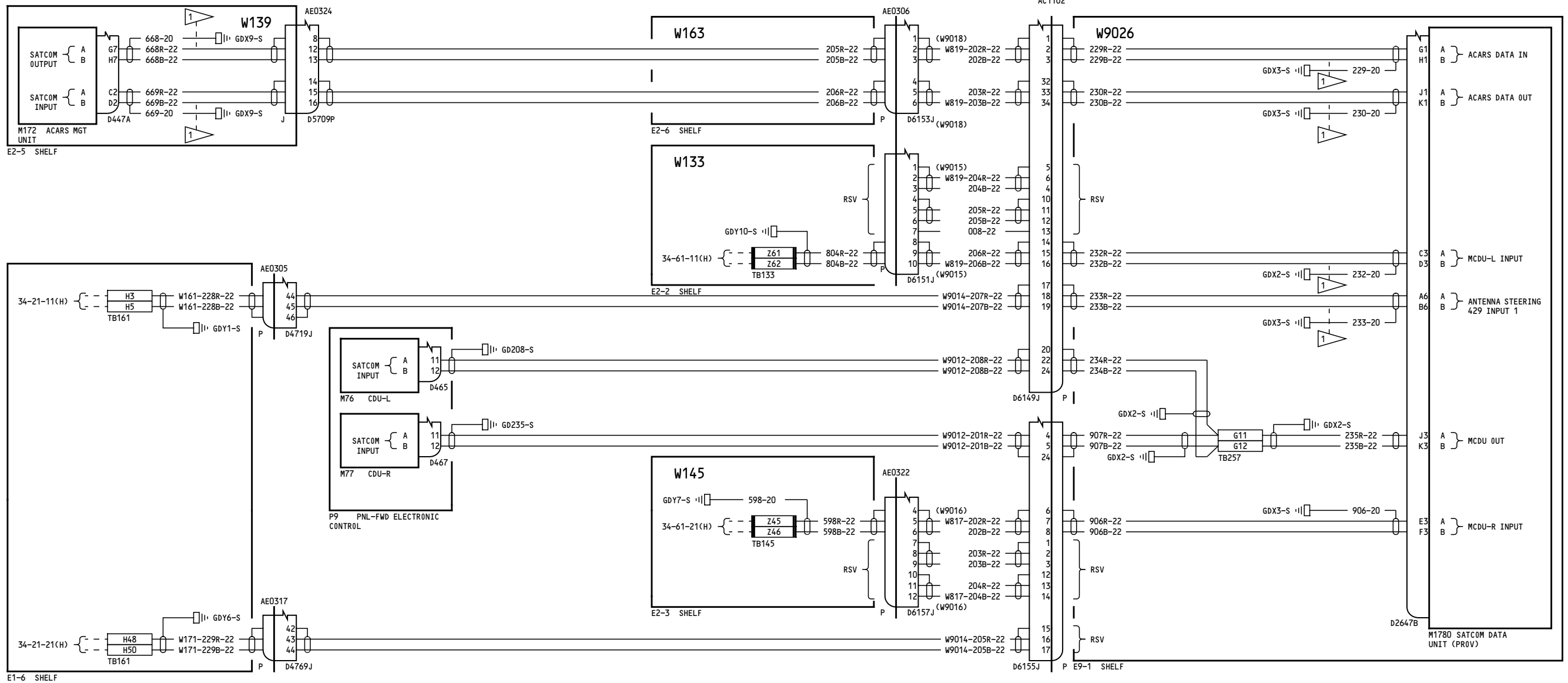

NOTES:
 1 MAXIMUM LENGTH OF GROUND WIRE SHALL NOT EXCEED 18 INCHES

150, 153-155

SATCOM SYSTEM-CONTROL INTERFACES

23-25-13

Page 1A
 Sheet 1
 Jan 21/2005

D280T132

Incorporates
 MTO 230593

23-25-13

Page 1A
 Sheet 1
 Jan 21/2005

-A
58

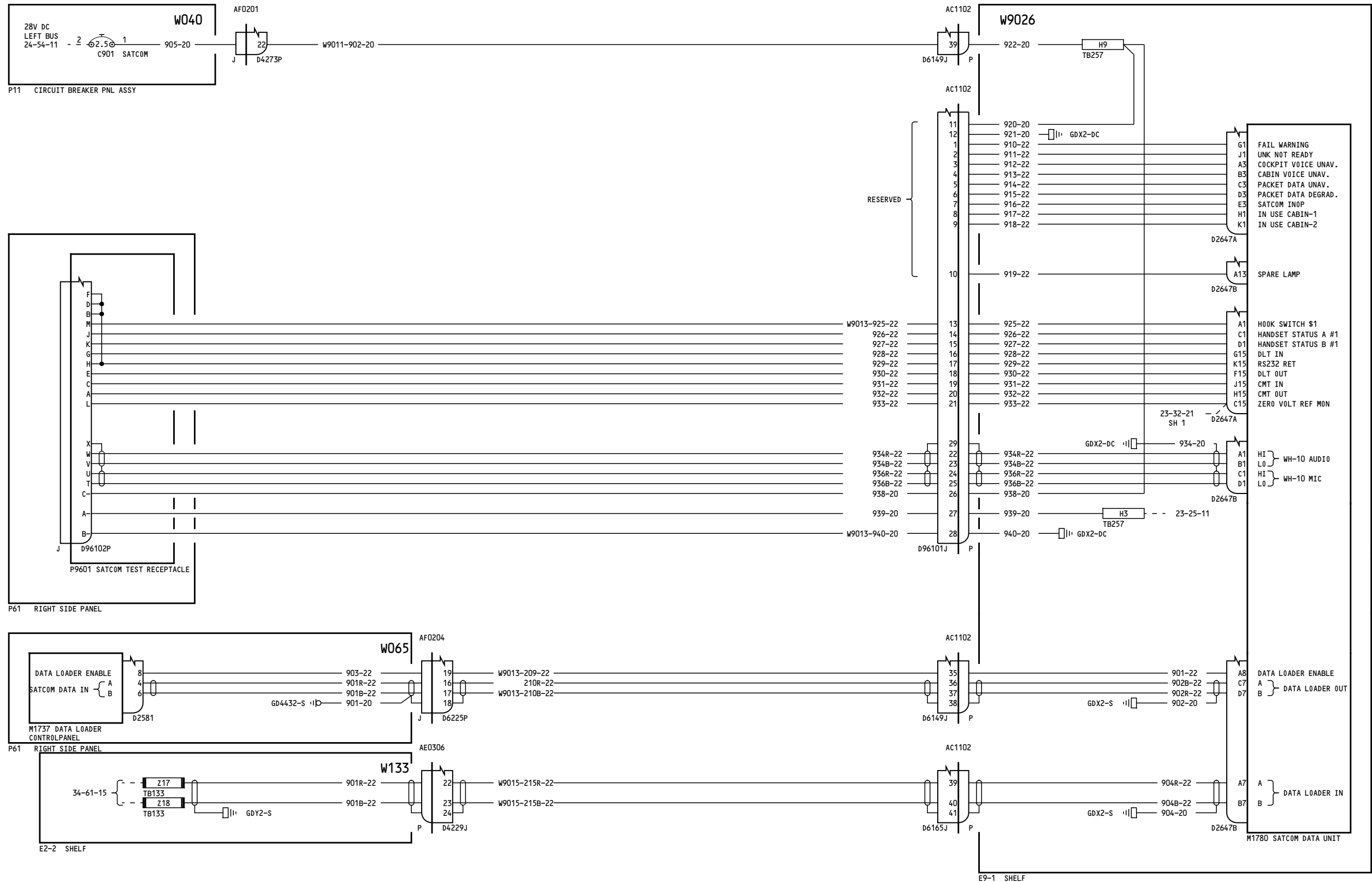

150, 153-155

SATCOM SYSTEM-CONTROL INTERFACES

23-25-13

Page 1A
Sheet 2
Jan 21/2005

D280T132

Incorporates
▶ MTO 230593
▶ MTO-230718

23-25-13

Page 1A
Sheet 2
Jan 21/2005

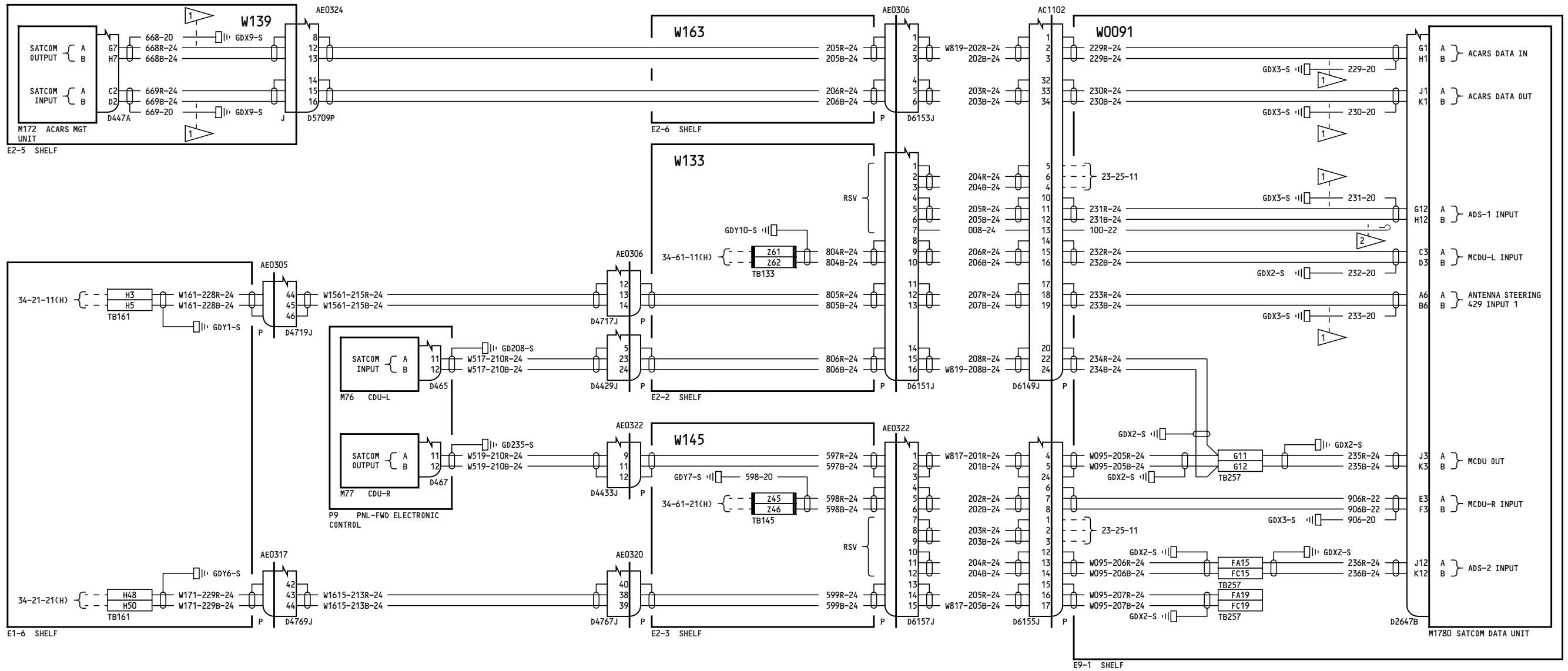

- NOTES:
- 1 MAXIMUM LENGTH OF GROUND WIRE SHALL NOT EXCEED 18 INCHES
 - 2 CAP & STOW NEAR D2647B

156-157, 166

SATCOM SYSTEM-CONTROL INTERFACES

D280T132

23-25-13

Page 2A
Sheet 1
Jan 21/2005

Incorporates
MTO 230591

23-25-13

Page 2A
Sheet 1
Jan 21/2005

-A
57

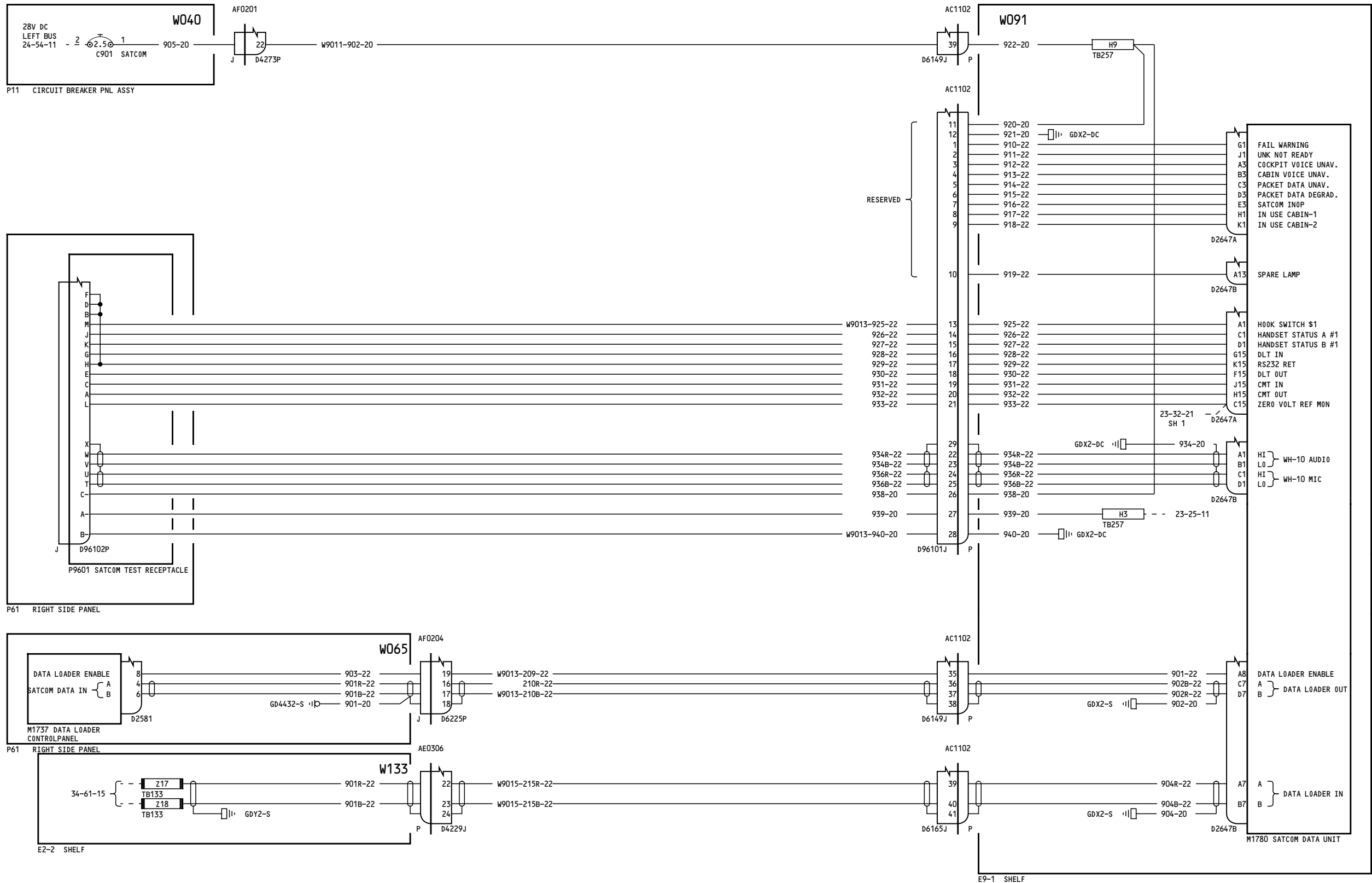

156-157, 166

SATCOM SYSTEM-CONTROL INTERFACES

23-25-13

Incorporates
 ▸ MTO 230591
 ▸ MTO-230718

23-25-13

D280T132

Page 2A
 Sheet 2
 Jan 21/2005

Page 2A
 Sheet 2
 Jan 21/2005

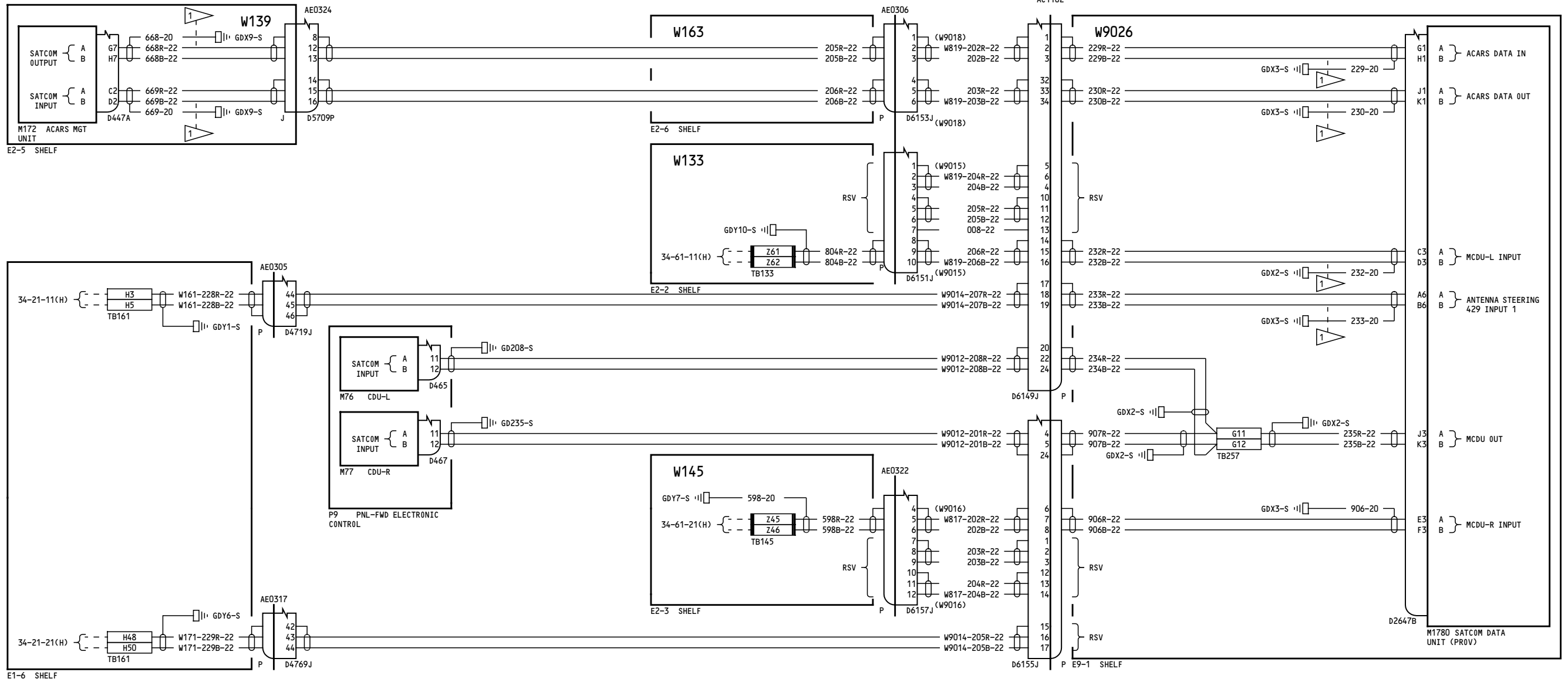

NOTES:
 1 MAXIMUM LENGTH OF GROUND WIRE SHALL NOT EXCEED 18 INCHES

162-165	SATCOM SYSTEM- CONTROL INTERFACES
D280T132	

23-25-13

Page 3A
 Sheet 1
 Jan 21/2005

Incorporates
 MTO 230592

23-25-13

Page 3A
 Sheet 1
 Jan 21/2005

-A
58

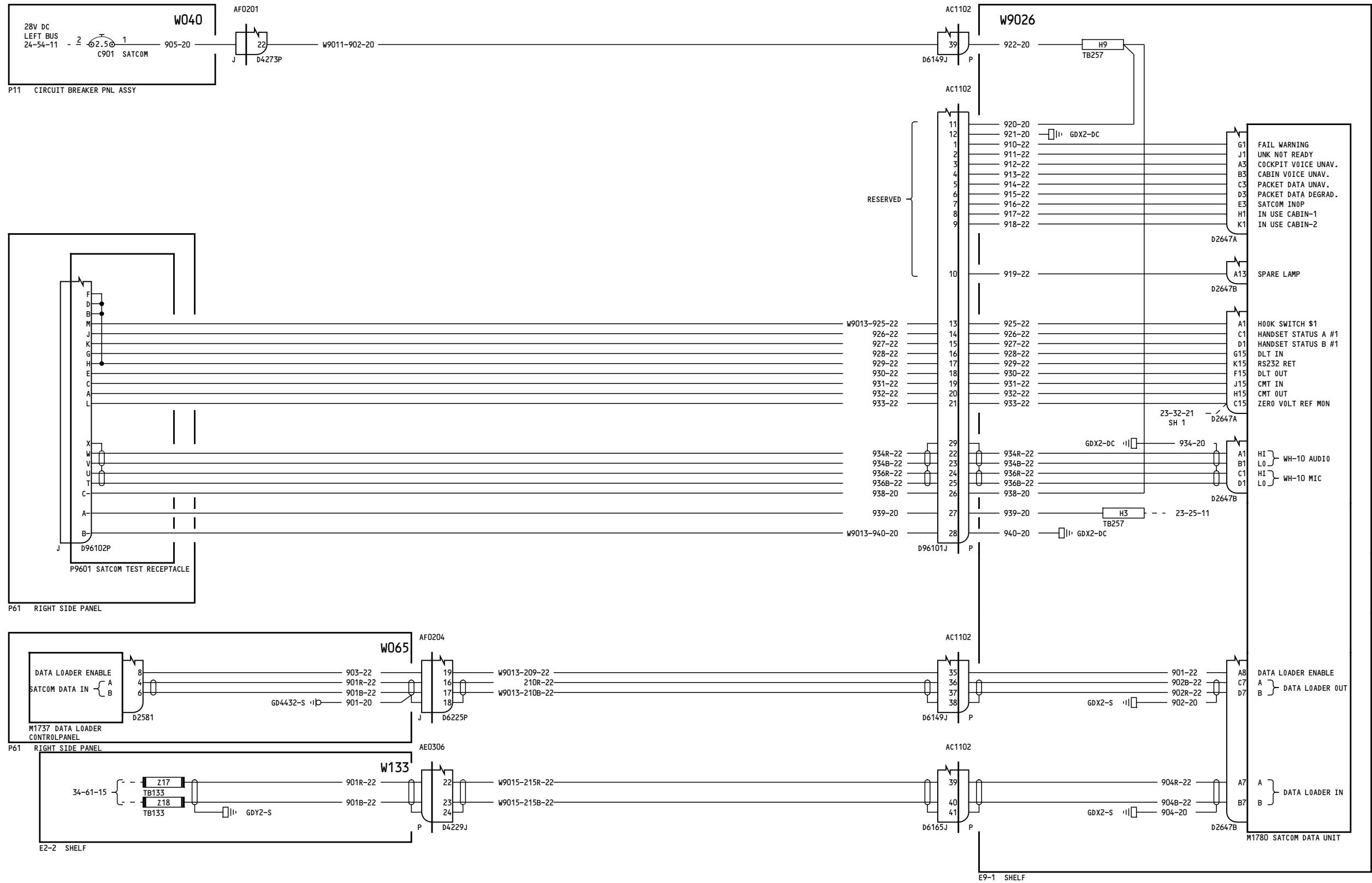

162-165

SATCOM SYSTEM-CONTROL INTERFACES

23-25-13

Page 3A
Sheet 2
Jan 21/2005

D280T132

Incorporates
MTO 230592
MTO-230718

23-25-13

Page 3A
Sheet 2
Jan 21/2005

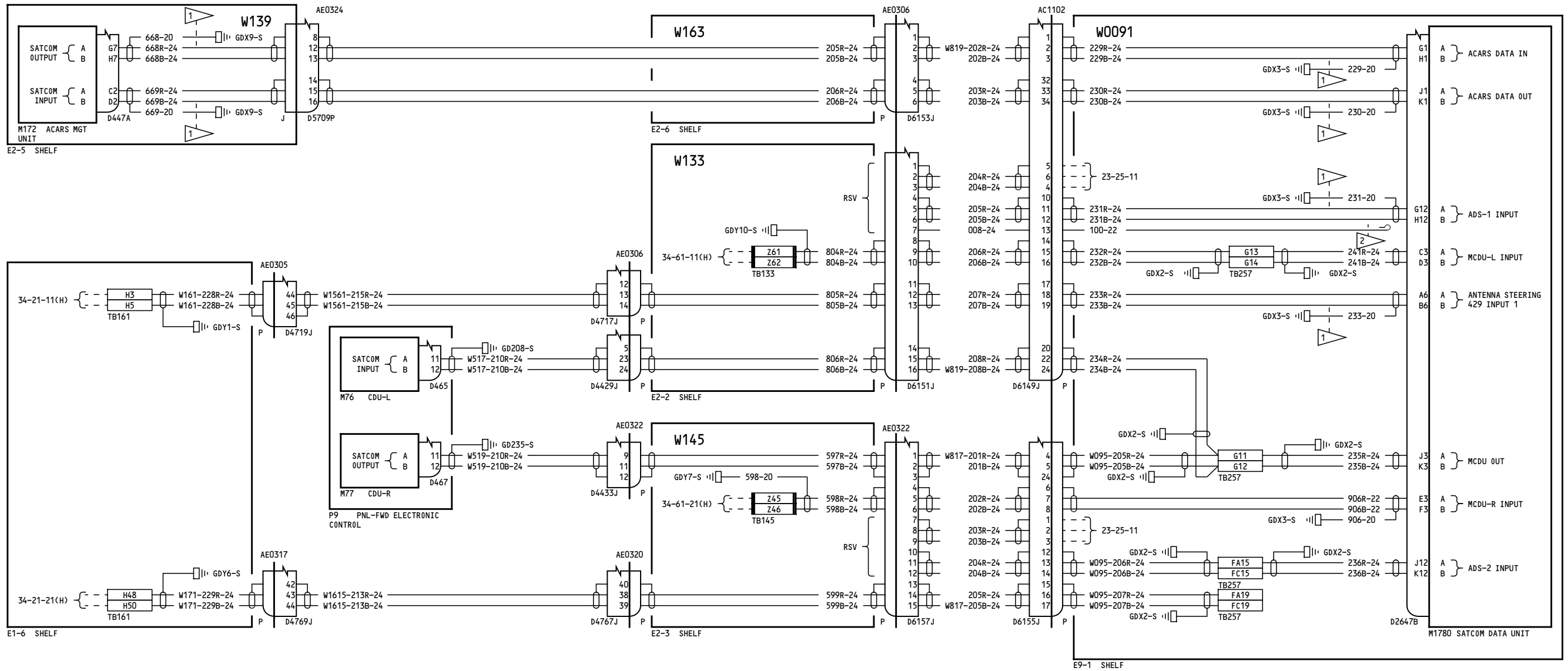

- NOTES:
- 1 MAXIMUM LENGTH OF GROUND WIRE SHALL NOT EXCEED 18 INCHES
 - 2 CAP & STOW NEAR D2647B

SATCOM SYSTEM-CONTROL INTERFACES

D280T132

23-25-13

Page 4A
Sheet 1
Jan 21/2005

Incorporates
MTO 230591

23-25-13

Page 4A
Sheet 1
Jan 21/2005

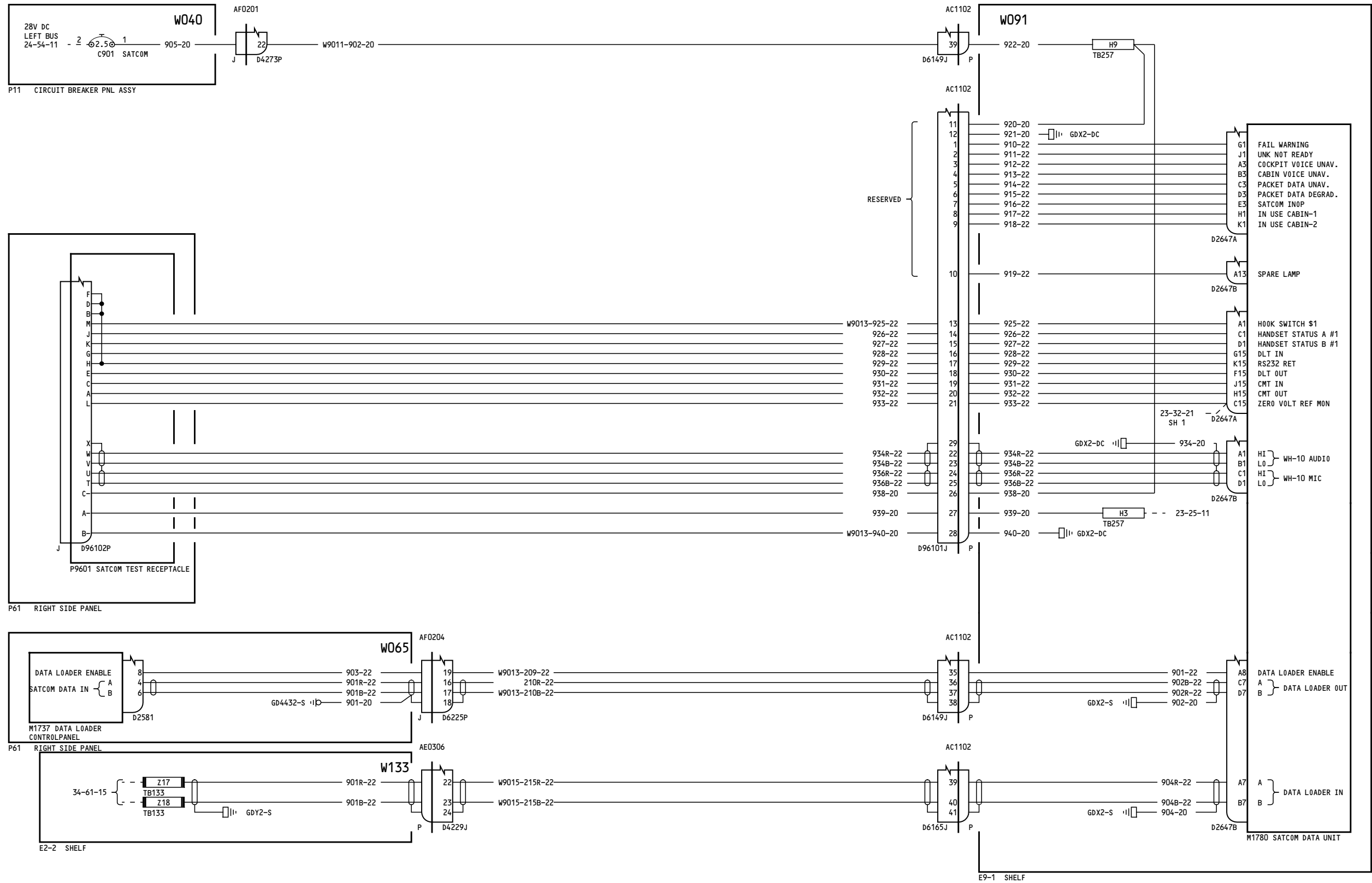

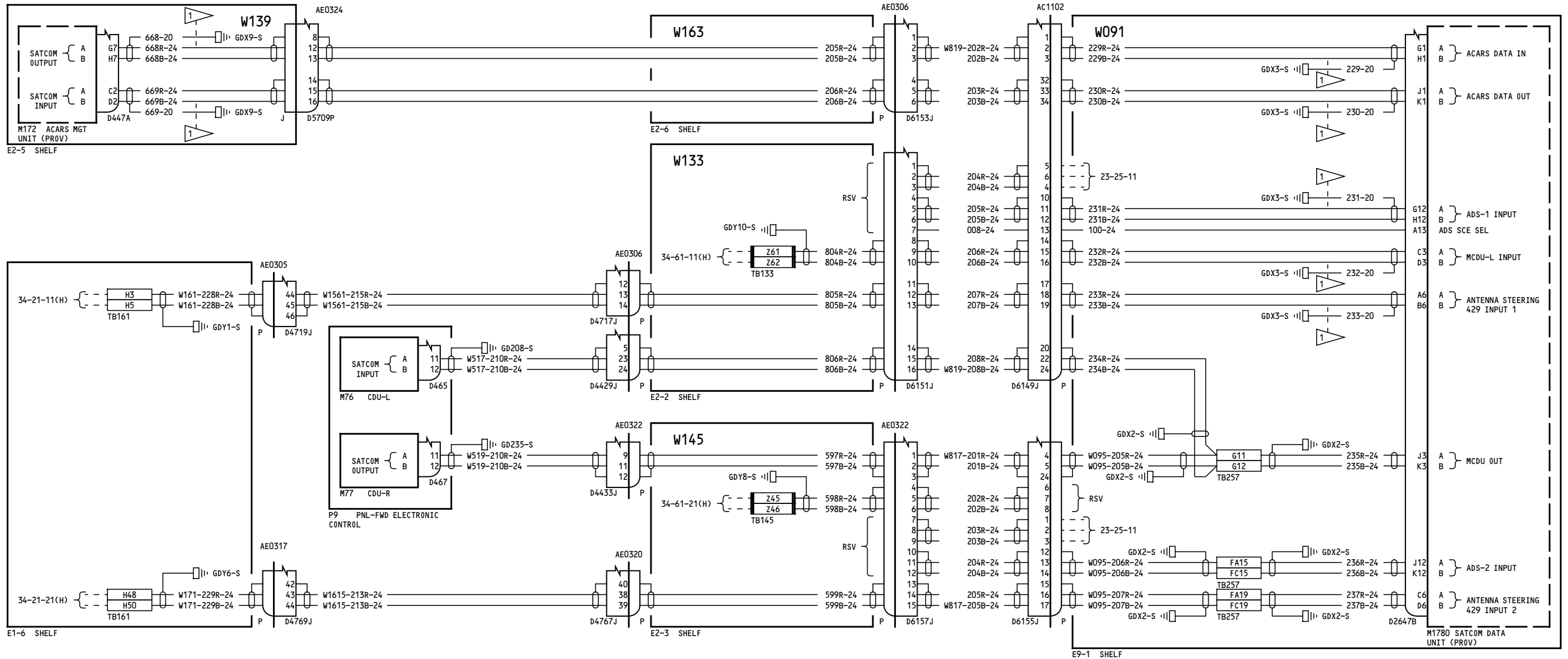

NOTES:
 1 MAXIMUM LENGTH OF GROUND WIRE SHALL NOT EXCEED 18 INCHES

<p>277-278</p>	<p>SATCOM SYSTEM-CONTROL INTERFACES</p> <p>23-25-13</p> <p>Page 5</p> <p>D280T132</p> <p>Jan 21/2005</p>
----------------	------------------------------------------------------------------------------------------------------------------------

-B
1

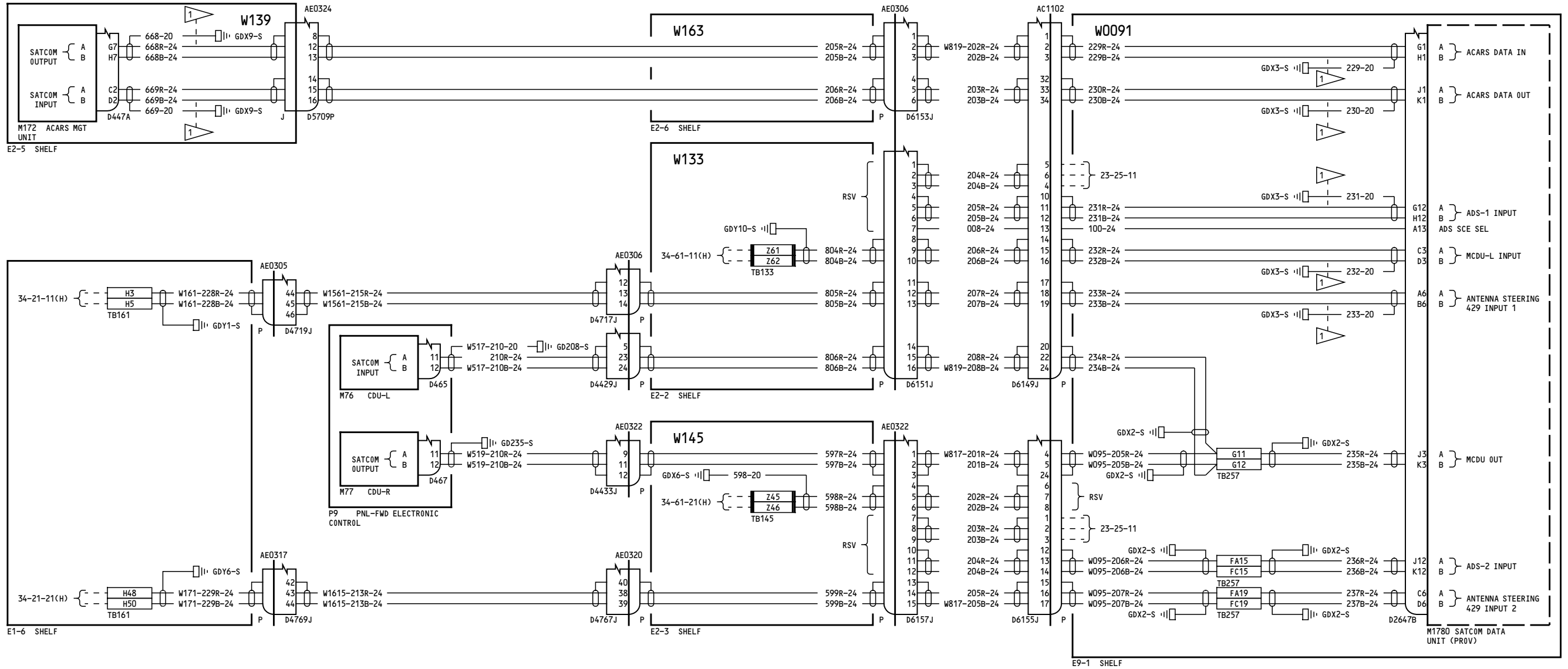

NOTES:
 1 MAXIMUM LENGTH OF GROUND WIRE SHALL NOT EXCEED 18 INCHES

<p>280-299</p>	<p>SATCOM SYSTEM- CONTROL INTERFACES</p> <p>23-25-13</p> <p>Page 6</p> <p>D280T132</p> <p>Jan 21/2005</p>
----------------	-----------------------------------------------------------------------------------------------------------------------------

23-25-13

Page 6

Jan 21/2005

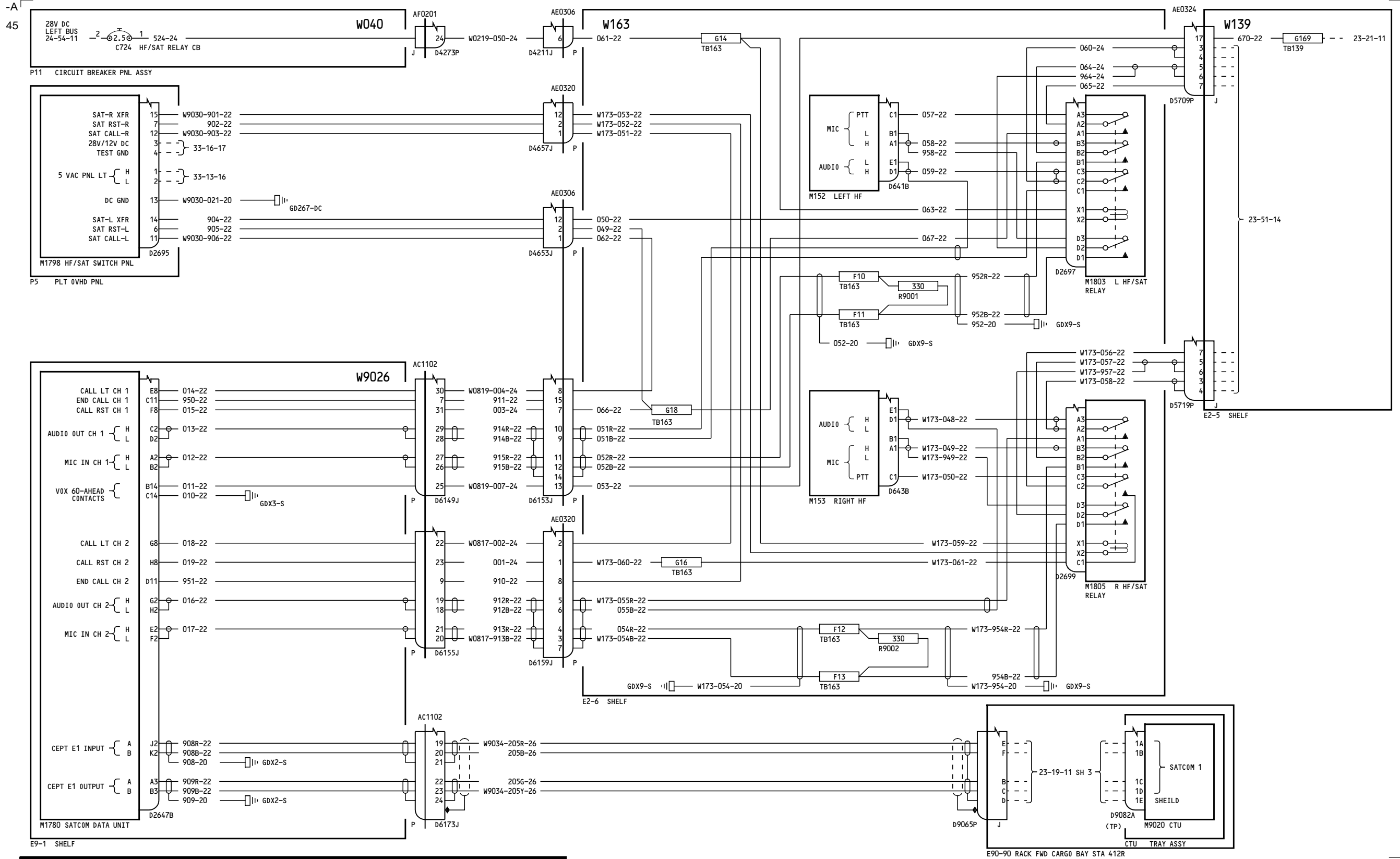

150

SATCOM SYSTEM-AUDIO INTERFACES

D280T132

23-25-14

Page 1A

Jan 21/2005

Incorporates

▶ MTO 230593

▶ MTO-230695

23-25-14

Page 1A

Jan 21/2005

82

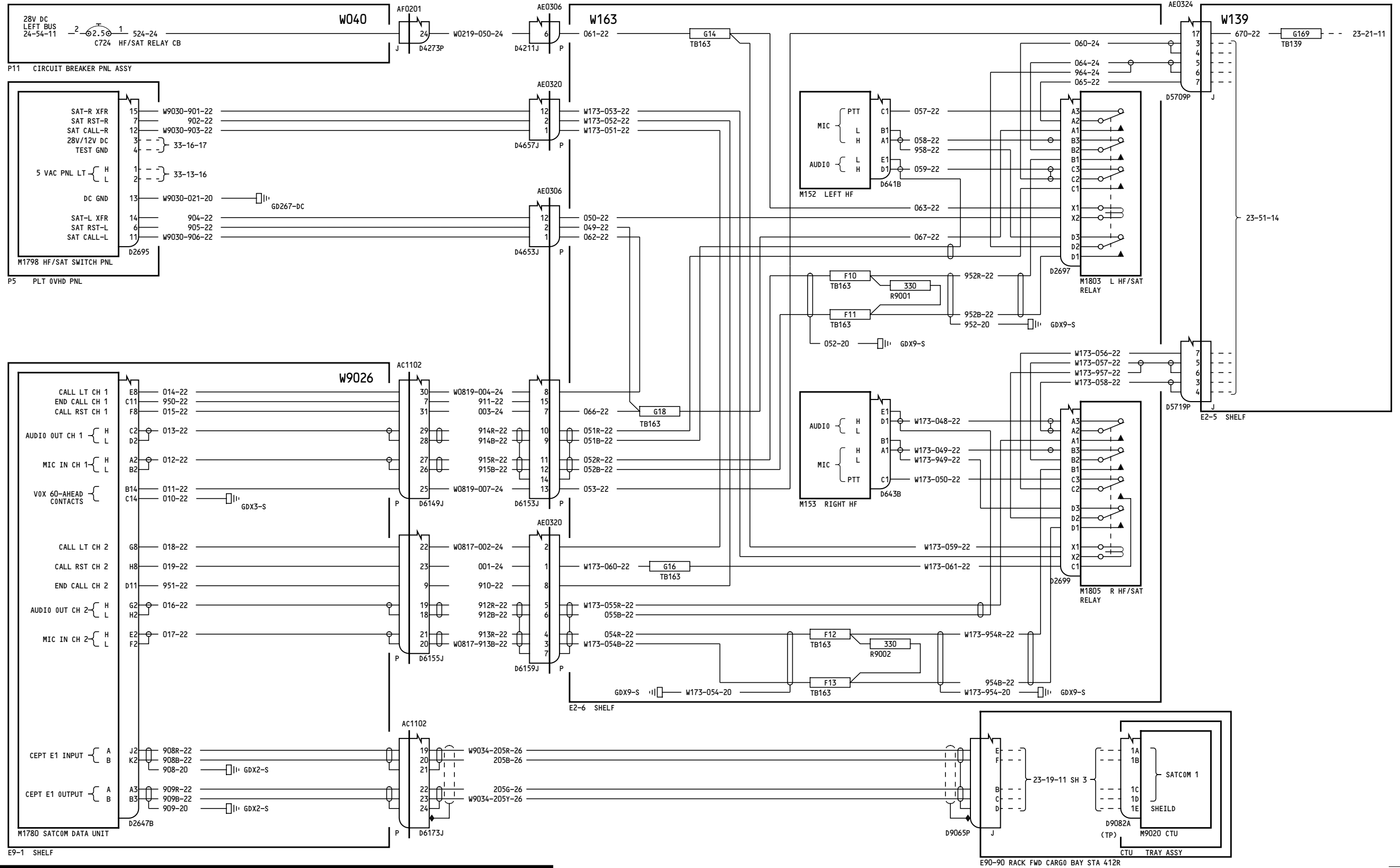

152

SATCOM SYSTEM-AUDIO INTERFACES

23-25-14

Page 2A

D280T132

Jan 21/2005

Incorporates MTO-230596

23-25-14

Page 2A

Jan 21/2005

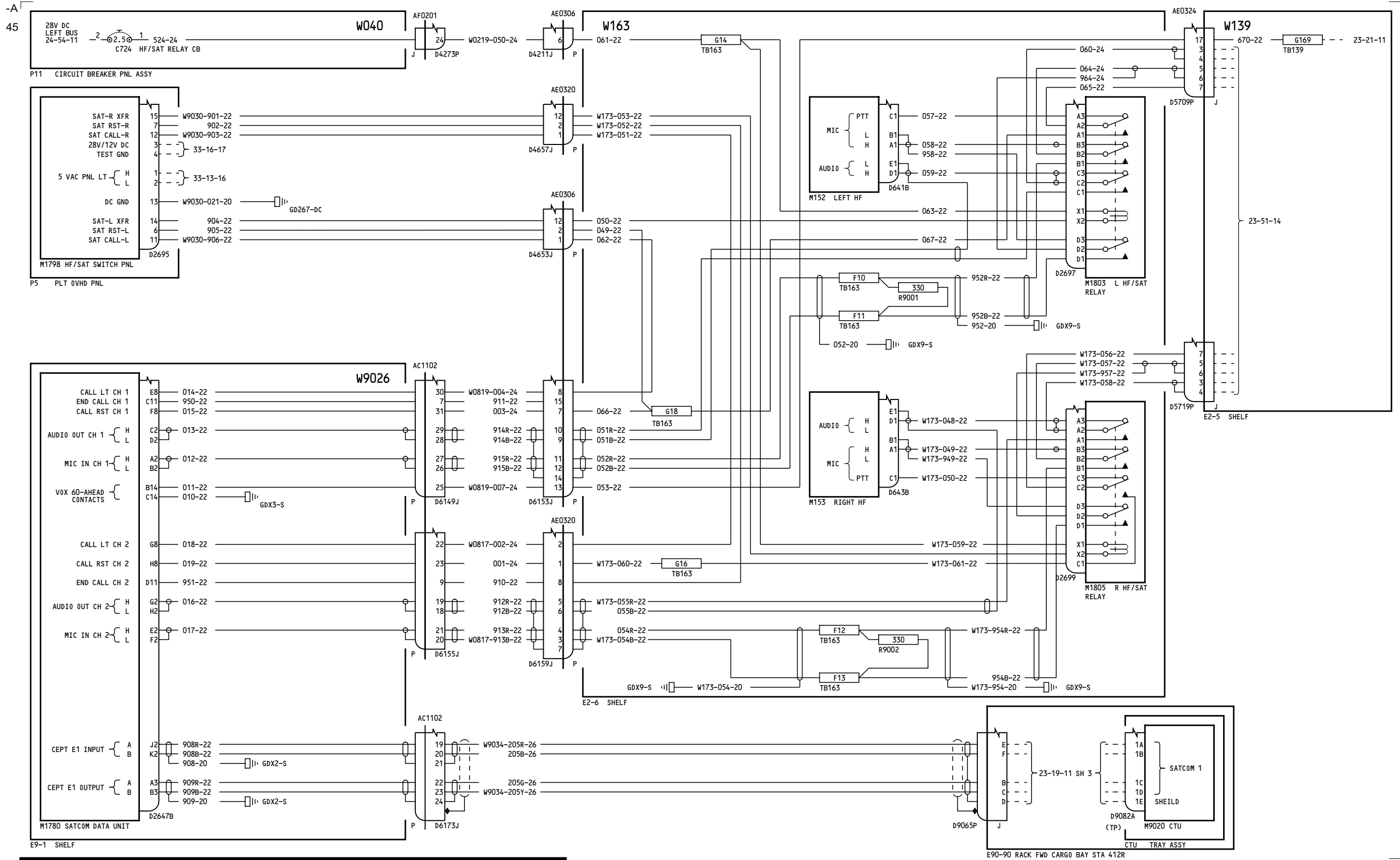

153-155

SATCOM SYSTEM-AUDIO INTERFACES

D280T132

23-25-14

Page 3A

Jan 21/2005

Incorporates
 MTO 230593
 MTO-230596

23-25-14

Page 3A

Jan 21/2005

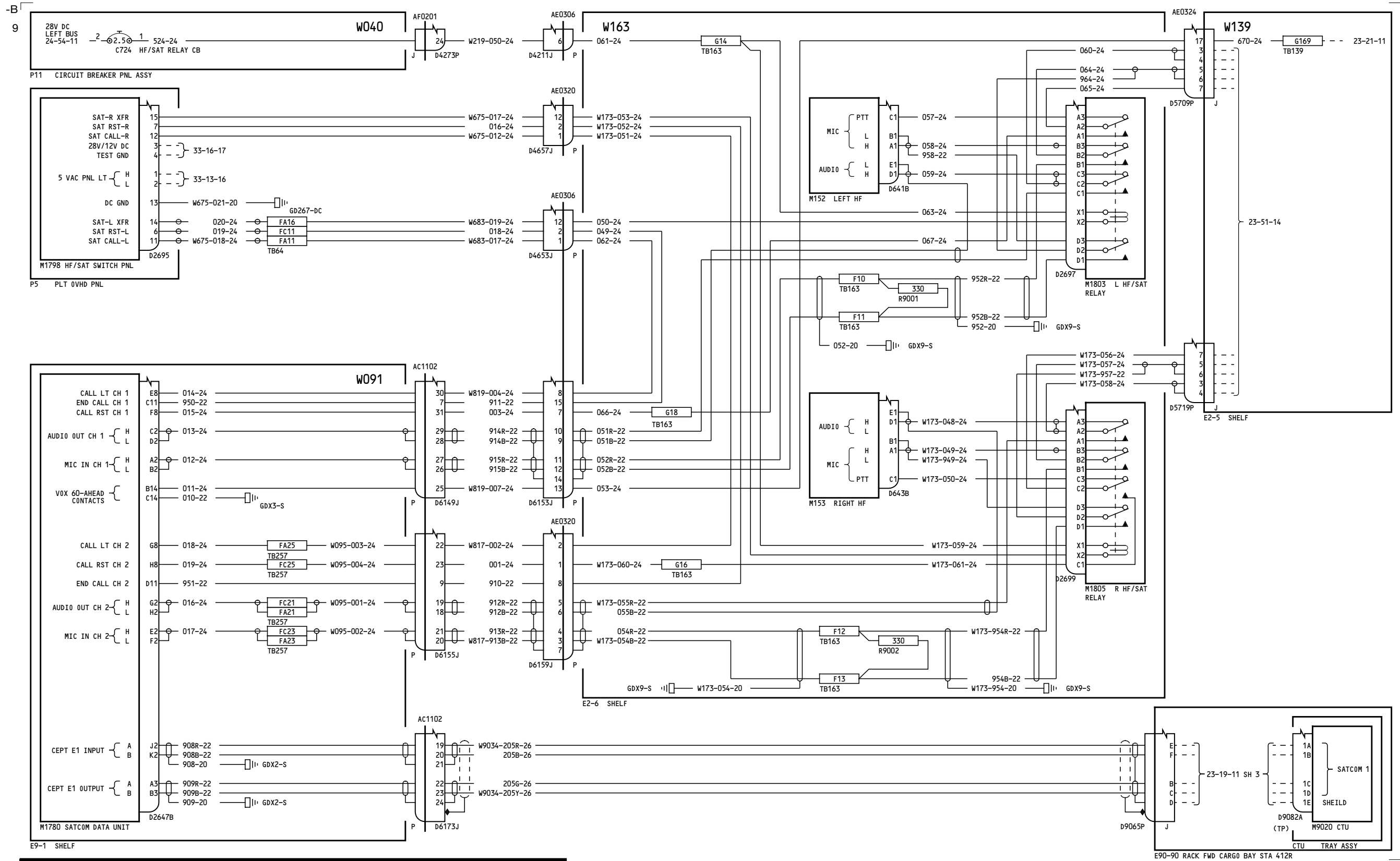

156-157, 166-167

SATCOM SYSTEM-AUDIO INTERFACES

23-25-14

Incorporates MTO 230591 MTO-230596

23-25-14

Page 4A

Page 4A

D280T132

Jan 21/2005

Jan 21/2005

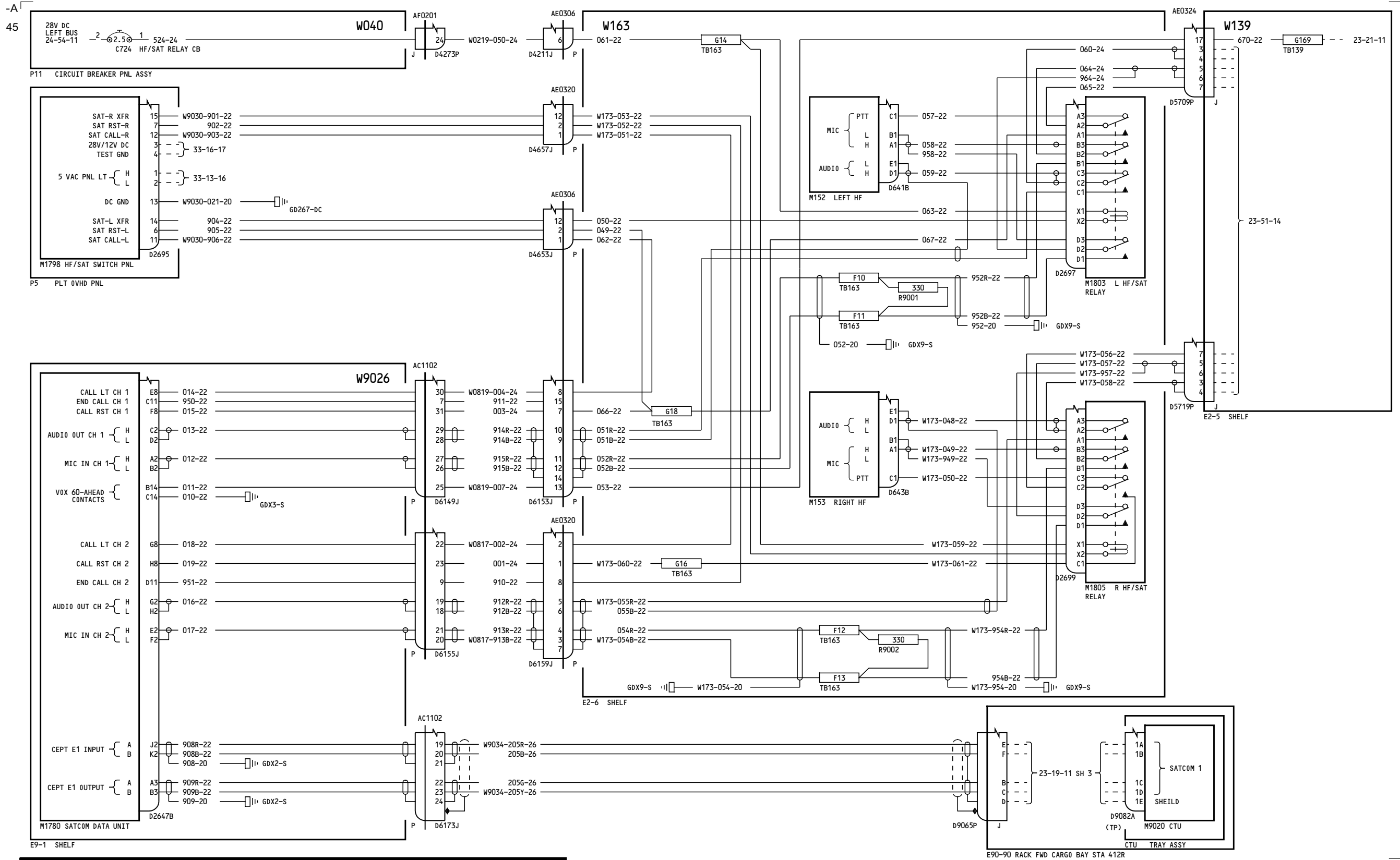

162-165

SATCOM SYSTEM-AUDIO INTERFACES

D280T132

23-25-14

Page 5A

Jan 21/2005

Incorporates

- MTO 230592
- MTO-230596

23-25-14

Page 5A

Jan 21/2005

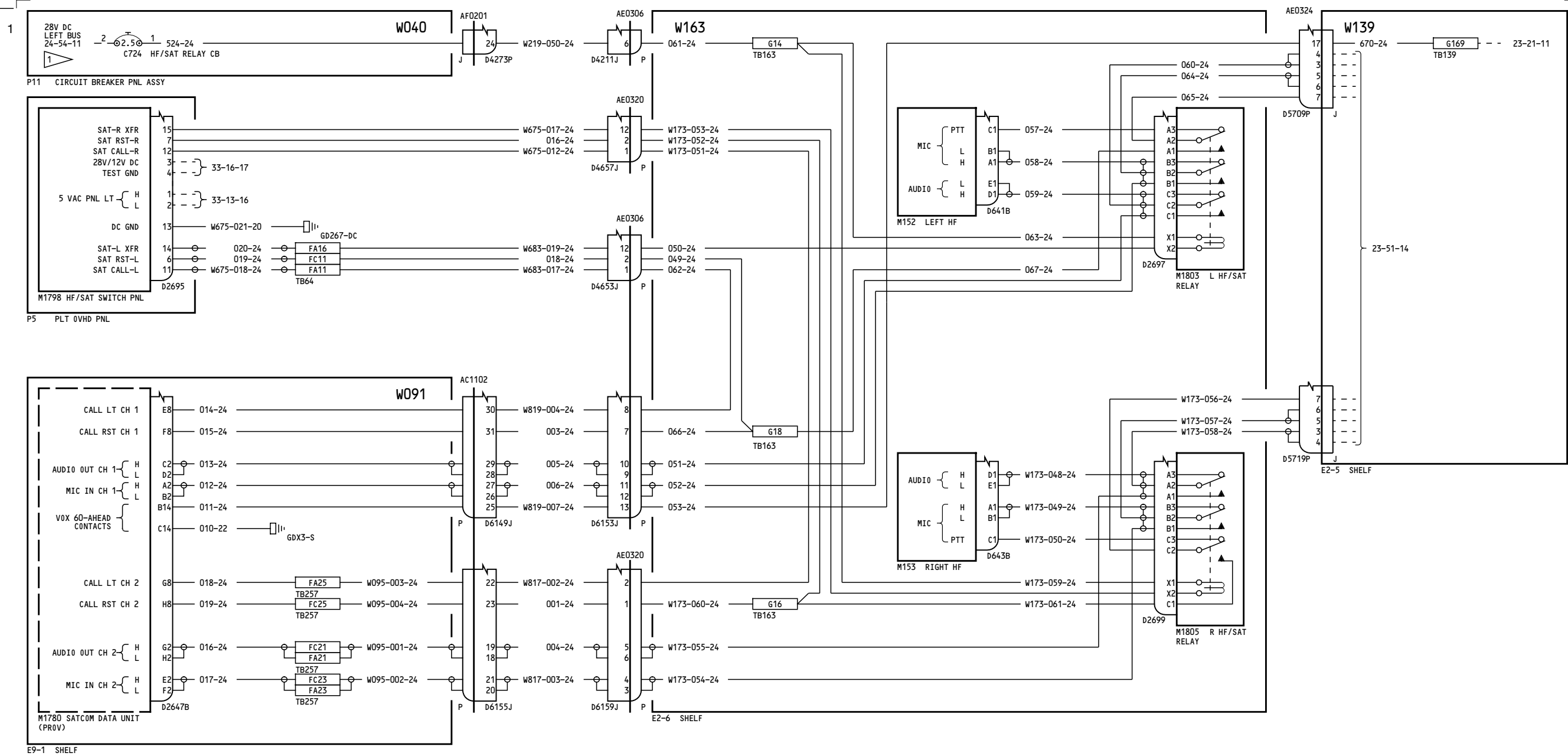

NOTES:
1 COLLAR AND LABEL INOP

277-299

SATCOM SYSTEM-AUDIO INTERFACES

D280T132

23-25-14

Page 6

Jan 21/2005

23-25-14

Page 6

Jan 21/2005

-A
55

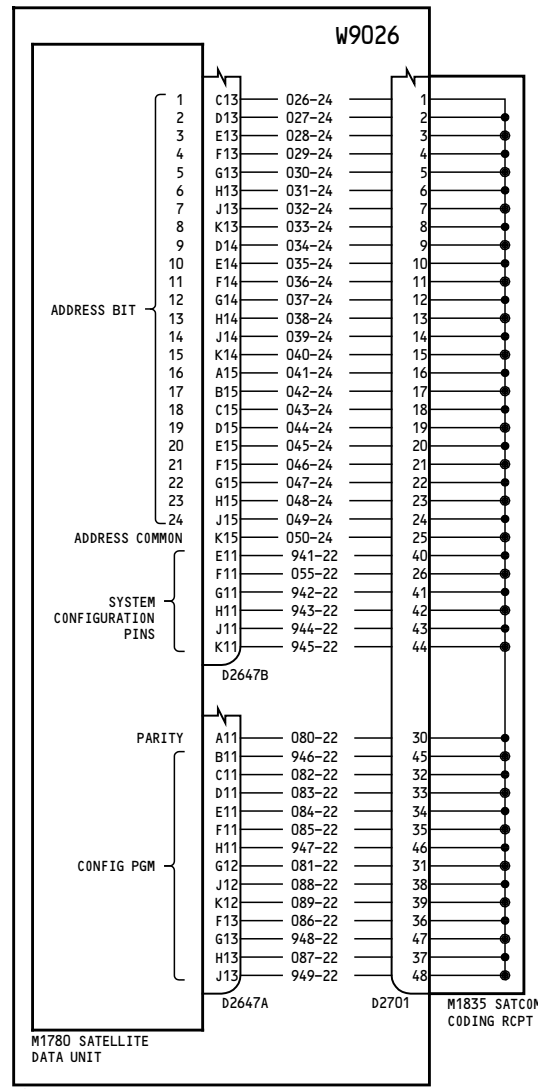

E9-1 SHELF

WIRING CHART

CODE SELECTION

EFF. CODE	AIRPLANE	WIRE NO.	CODE SELECTION																																														
			026-22	027-22	028-22	029-22	030-22	031-22	032-22	033-22	034-22	035-22	036-22	037-22	038-22	039-22	040-22	041-22	042-22	043-22	044-22	045-22	046-22	047-22	048-22	049-22	050-22	056-22	080-22	081-22	082-22	083-22	084-22	085-22	086-22	087-22	088-22	089-22	941-22	942-22	943-22	944-22	945-22	946-22	947-22	948-22	949-22		
150	VN151		0	1	0	0	0	1	1	1	1	0	0	0	0	0	0	0	0	1	0	1	1	1	1	0	1	1	1	0	1	1	1	1	0	0	0	0	1	1	1	1	1	0	0	0	0		
153	VN154		0	1	0	0	0	1	1	1	1	0	0	0	0	0	0	0	1	0	1	0	1	1	0	1	1	1	0	1	1	1	1	0	0	0	0	0	1	1	1	1	1	1	0	0	0	0	
154	VN155		0	1	0	0	0	1	1	1	1	0	0	0	0	0	0	0	1	0	0	0	1	0	0	0	1	1	1	0	1	1	1	1	0	0	0	0	0	1	1	1	1	1	1	0	0	0	0
155	VN156		0	1	0	0	0	1	0	1	1	0	1	0	1	1	0	0	1	0	0	0	1	1	0	0	0	1	1	1	0	1	1	1	1	0	0	0	0	1	1	1	1	1	1	0	0	0	0
162	VN163		0	1	0	0	0	1	1	1	1	0	0	0	0	0	0	0	0	1	1	0	1	0	1	1	1	1	0	1	1	1	1	0	0	0	0	0	1	1	1	1	1	1	0	0	0	0	
163	VN164		0	1	0	0	0	1	1	1	1	0	0	0	0	0	0	0	1	0	0	0	0	0	0	0	1	1	1	0	1	1	1	1	0	0	0	0	1	1	1	1	1	1	0	0	0	0	
164	VN165		0	1	0	0	0	1	0	1	1	0	1	0	1	1	0	0	1	0	0	0	1	1	1	0	0	1	1	1	0	1	1	1	1	0	0	0	0	1	1	1	1	1	0	0	0	0	

NOTES:
1 SEE WIRING CHART FOR HOOK-UP INFORMATION
LOGIC 0: INSTALL THE WIRES
LOGIC 1: DO NOT INSTALL THE WIRES

150, 153-155

SATCOM ADDRESS CODING

23-25-15

Page 1A

Jan 21/2005

D280T132

Incorporates
MTO 230593

23-25-15

Page 1A

Jan 21/2005

-A
12

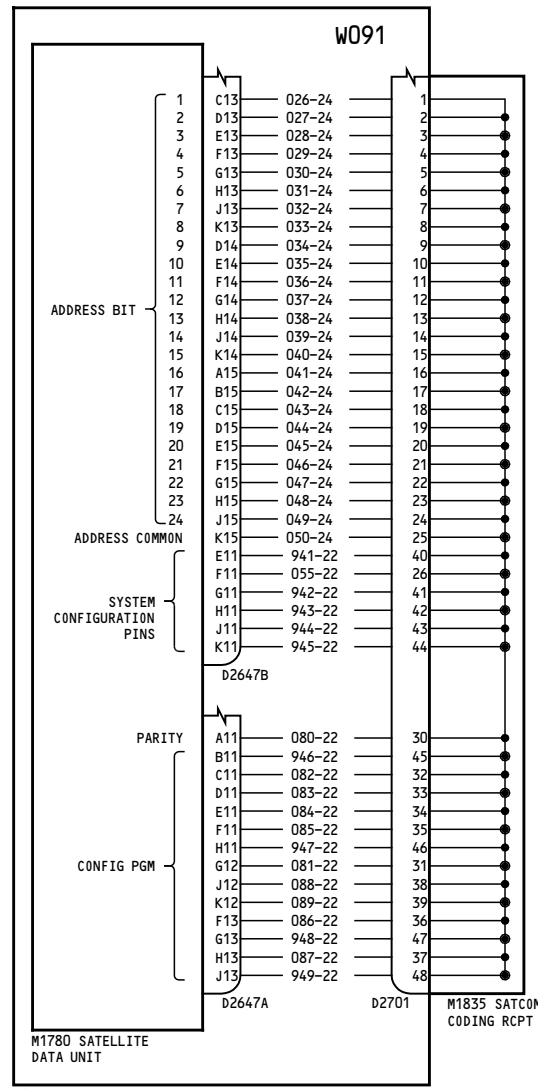

E9-1 SHELF

WIRING CHART

CODE SELECTION

EFF. CODE	AIRPLANE	WIRE NO.	026-22	027-22	028-22	029-22	030-22	031-22	032-22	033-22	034-22	035-22	036-22	037-22	038-22	039-22	040-22	041-22	042-22	043-22	044-22	045-22	046-22	047-22	048-22	049-22	050-22	056-22	080-22	081-22	082-22	083-22	084-22	085-22	086-22	087-22	088-22	089-22	941-22	942-22	943-22	944-22	945-22	946-22	947-22	948-22	949-22	
156	VN157		0	1	0	0	0	1	1	1	1	0	0	0	0	0	0	0	0	0	1	1	0	0	0	1	0	1	1	1	0	1	1	1	0	0	0	0	1	1	1	1	1	0	0	0	0	
157	VN158		0	1	0	0	0	1	1	1	1	0	0	0	0	0	0	0	0	0	1	1	0	0	1	0	1	1	1	0	1	1	1	1	0	0	0	0	1	1	1	1	1	0	0	0	0	
166	VN167		0	1	0	0	0	1	0	1	1	0	1	0	1	1	0	0	1	1	0	1	0	1	0	1	0	1	1	1	0	1	1	1	1	0	0	0	0	1	1	1	1	1	0	0	0	0
167	VN168		0	1	0	0	0	1	1	1	1	0	0	0	0	0	0	0	0	1	0	0	1	1	0	0	0	1	1	1	0	1	1	1	1	0	0	0	0	1	1	1	1	1	0	0	0	0

NOTES:
 1 SEE WIRING CHART FOR HOOK-UP INFORMATION
 LOGIC 0: INSTALL THE WIRES
 LOGIC 1: DO NOT INSTALL THE WIRES

156-157, 166-167

SATCOM ADDRESS CODING

23-25-15

Page 2A

Jan 21/2005

D280T132

Incorporates
 MTO 230591

23-25-15

Page 2A

Jan 21/2005

-A
55

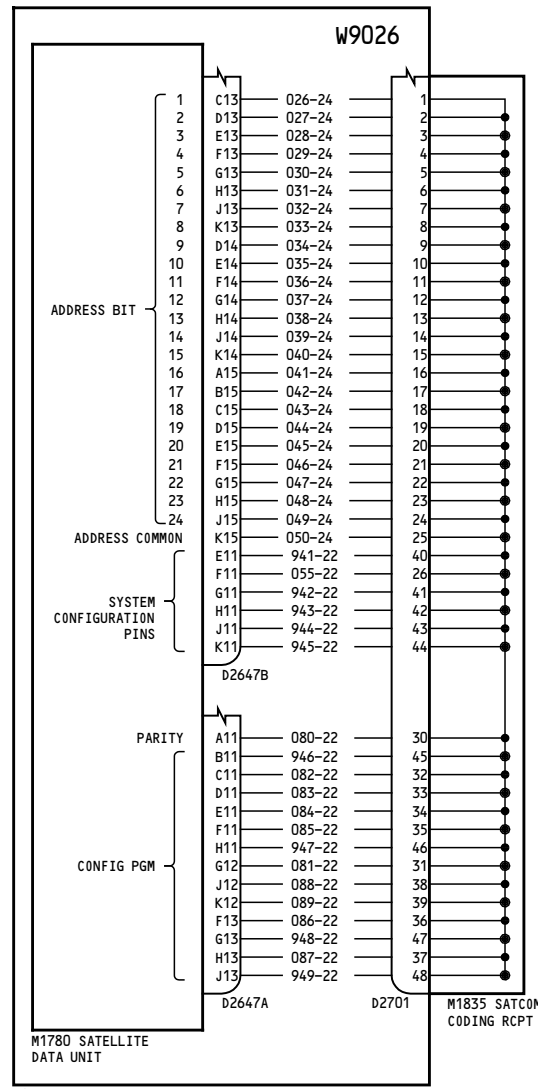

E9-1 SHELF

WIRING CHART

CODE SELECTION

EFF. CODE	AIRPLANE	WIRE NO.	CODE SELECTION																																													
			026-22	027-22	028-22	029-22	030-22	031-22	032-22	033-22	034-22	035-22	036-22	037-22	038-22	039-22	040-22	041-22	042-22	043-22	044-22	045-22	046-22	047-22	048-22	049-22	050-22	056-22	080-22	081-22	082-22	083-22	084-22	085-22	086-22	087-22	088-22	089-22	941-22	942-22	943-22	944-22	945-22	946-22	947-22	948-22	949-22	
150	VN151		0	1	0	0	0	1	1	1	1	0	0	0	0	0	0	0	0	1	0	1	1	1	1	0	1	1	1	0	1	1	1	1	0	0	0	0	1	1	1	1	1	0	0	0	0	
153	VN154		0	1	0	0	0	1	1	1	1	0	0	0	0	0	0	0	1	0	1	0	1	1	0	1	1	1	0	1	1	1	1	0	0	0	0	0	1	1	1	1	1	0	0	0	0	
154	VN155		0	1	0	0	0	1	1	1	1	0	0	0	0	0	0	0	1	0	0	0	1	0	0	0	1	1	1	0	1	1	1	1	0	0	0	0	0	1	1	1	1	1	0	0	0	0
155	VN156		0	1	0	0	0	1	0	1	1	0	1	0	1	1	0	0	1	0	0	0	1	1	0	0	0	1	1	1	0	1	1	1	1	0	0	0	0	1	1	1	1	1	0	0	0	0
162	VN163		0	1	0	0	0	1	1	1	1	0	0	0	0	0	0	0	0	1	1	0	1	0	1	1	1	1	0	1	1	1	1	0	0	0	0	0	1	1	1	1	1	0	0	0	0	
163	VN164		0	1	0	0	0	1	1	1	1	0	0	0	0	0	0	0	1	0	0	0	0	0	0	0	1	1	1	0	1	1	1	1	0	0	0	0	1	1	1	1	1	0	0	0	0	
164	VN165		0	1	0	0	0	1	0	1	1	0	1	0	1	1	0	0	1	0	0	0	1	1	1	0	0	1	1	1	0	1	1	1	1	0	0	0	0	1	1	1	1	1	0	0	0	0

NOTES:
1 SEE WIRING CHART FOR HOOK-UP INFORMATION
LOGIC 0: INSTALL THE WIRES
LOGIC 1: DO NOT INSTALL THE WIRES

162-164

SATCOM ADDRESS CODING

23-25-15

Page 3A

Jan 21/2005

D280T132

Incorporates
MTO 230592

23-25-15

Page 3A

Jan 21/2005

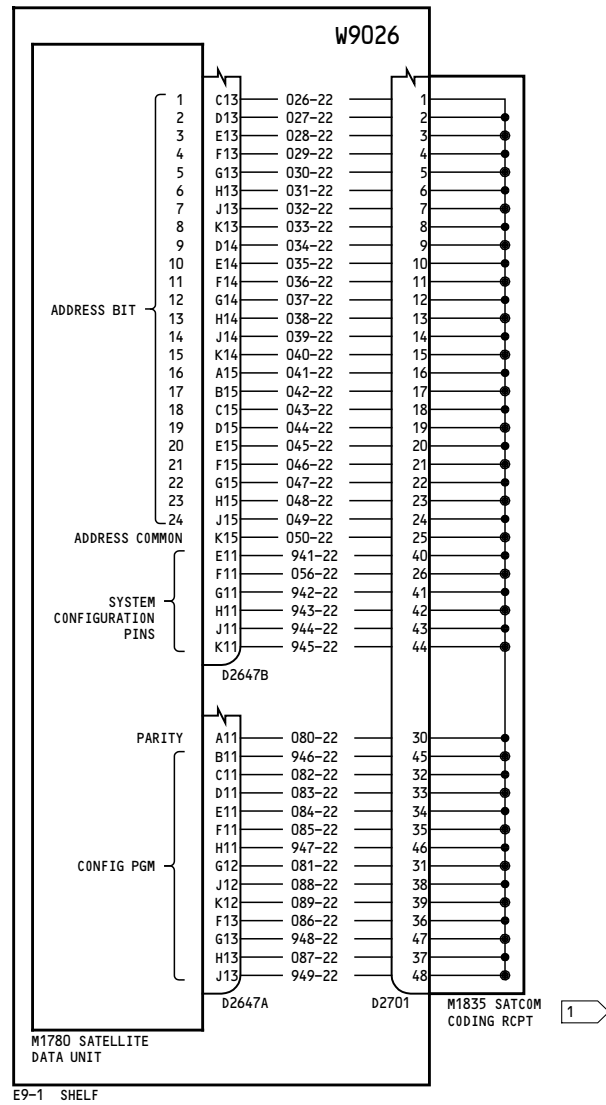

WIRING CHART

EFF. CODE	AIRPLANE	WIRE NO.	CODE SELECTION																																												
			026-22	027-22	028-22	029-22	030-22	031-22	032-22	033-22	034-22	035-22	036-22	037-22	038-22	039-22	040-22	041-22	042-22	043-22	044-22	045-22	046-22	047-22	048-22	049-22	050-22	056-22	080-22	081-22	082-22	083-22	084-22	085-22	086-22	087-22	088-22	089-22	941-22	942-22	943-22	944-22	945-22	946-22	947-22	948-22	949-22
165	VN166		0	1	0	0	0	1	1	1	1	0	0	0	0	1	1	0	1	0	1	1	1	0	1	0	1	1	1	0	1	1	1	0	0	0	0	0	1	1	1	1	1	0	0	0	0

NOTES:
 1 SEE WIRING CHART FOR HOOK-UP INFORMATION
 LOGIC 0: INSTALL THE WIRES
 LOGIC 1: DO NOT INSTALL THE WIRES

165

SATCOM ADDRESS CODING

D280T132

23-25-15

Page 4A

Jan 21/2005

Incorporates
 MTO 230592
 PR00073

23-25-15

Page 4A

Jan 21/2005

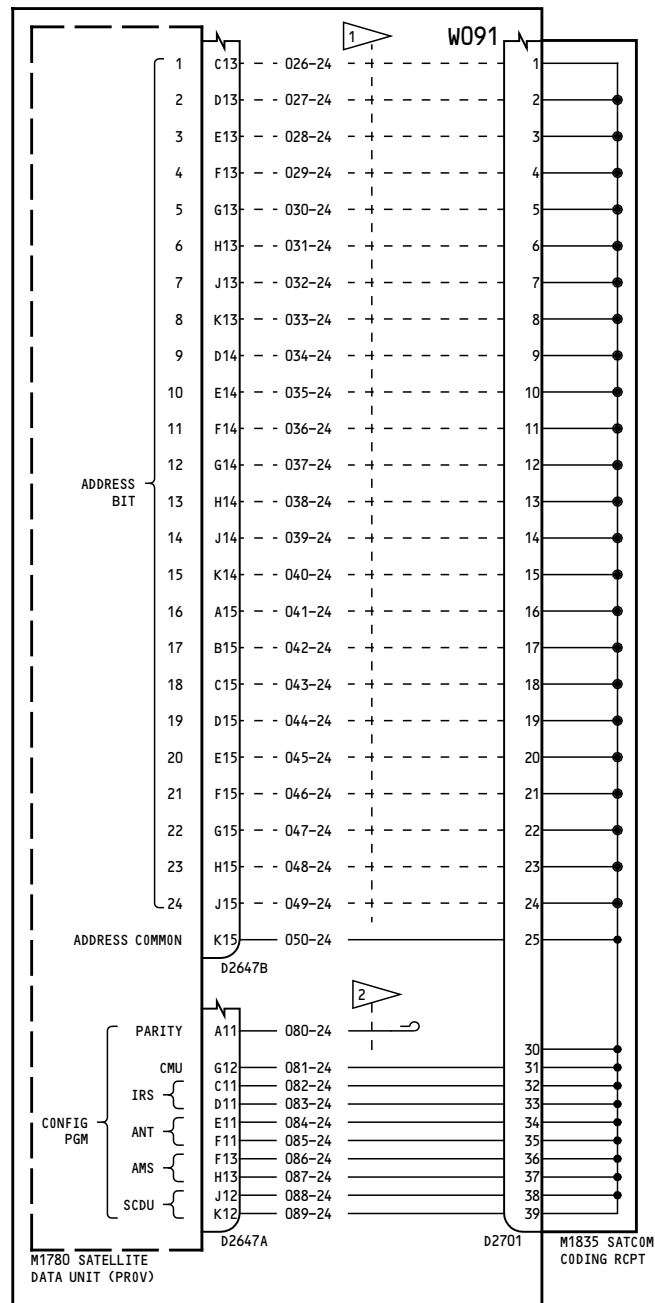

E9-1 SHELF

NOTES:
 1 SEE WIRING CHART FOR HOOK-UP INFORMATION
 LOGIC 0: INSTALL THE WIRES
 LOGIC 1: DO NOT INSTALL THE WIRES
 2 CAP & STOW NEAR D2701

277-299

SATCOM ADDRESS CODING

23-25-15

Page 5

Jan 21/2005

D280T132

WIRING CHART

OCTAL CODE	AIRPLANE	CODE SELECTION																									
		WIRE NO.	26-24	27-24	28-24	29-24	30-24	31-24	32-24	33-24	34-24	35-24	36-24	37-24	38-24	39-24	40-24	41-24	42-24	43-24	44-24	45-24	46-24	47-24	48-24	49-24	
22500034	VN157		0	1	0	0	1	0	1	0	1	0	0	0	0	0	0	0	0	0	0	0	1	1	1	0	0
22500036	VN158		0	1	0	0	1	0	1	0	1	0	0	0	0	0	0	0	0	0	0	0	1	1	1	1	0
21326215	VN167		0	1	0	0	0	1	0	1	1	0	1	0	1	1	0	0	1	0	0	0	1	1	0	1	
22040105	VN223		0	1	0	0	1	0	0	0	0	1	0	0	0	0	0	0	0	0	1	0	0	0	1	0	1
22040110	VN224		0	1	0	0	1	0	0	0	0	1	0	0	0	0	0	0	0	1	0	0	1	0	0	0	
22040106	VN671		0	1	0	0	1	0	0	0	0	1	0	0	0	0	0	0	0	1	0	0	0	1	1	0	
22040107	VN672		0	1	0	0	1	0	0	0	0	1	0	0	0	0	0	0	0	1	0	0	0	1	1	1	

23-25-15

Page 5

Jan 21/2005

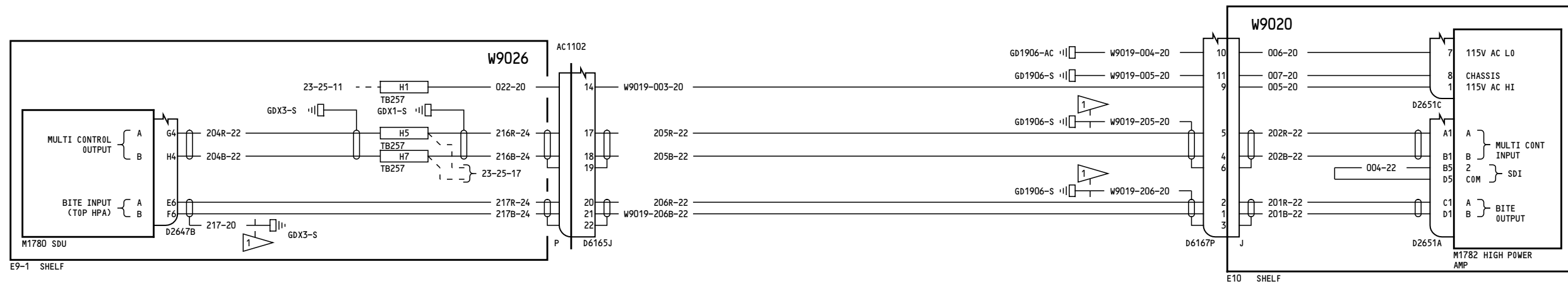

NOTES:
 1 MAX LENGTH OF GROUND WIRE SHALL NOT EXCEED 18 INCHES

150, 153-155

**SATCOM SYSTEM-
 TOP MOUNTED HGA
 SYSTEM**

23-25-16

Page 1A

D280T132

Jan 21/2005

Incorporates
 MTO 230593

23-25-16

Page 1A

Jan 21/2005

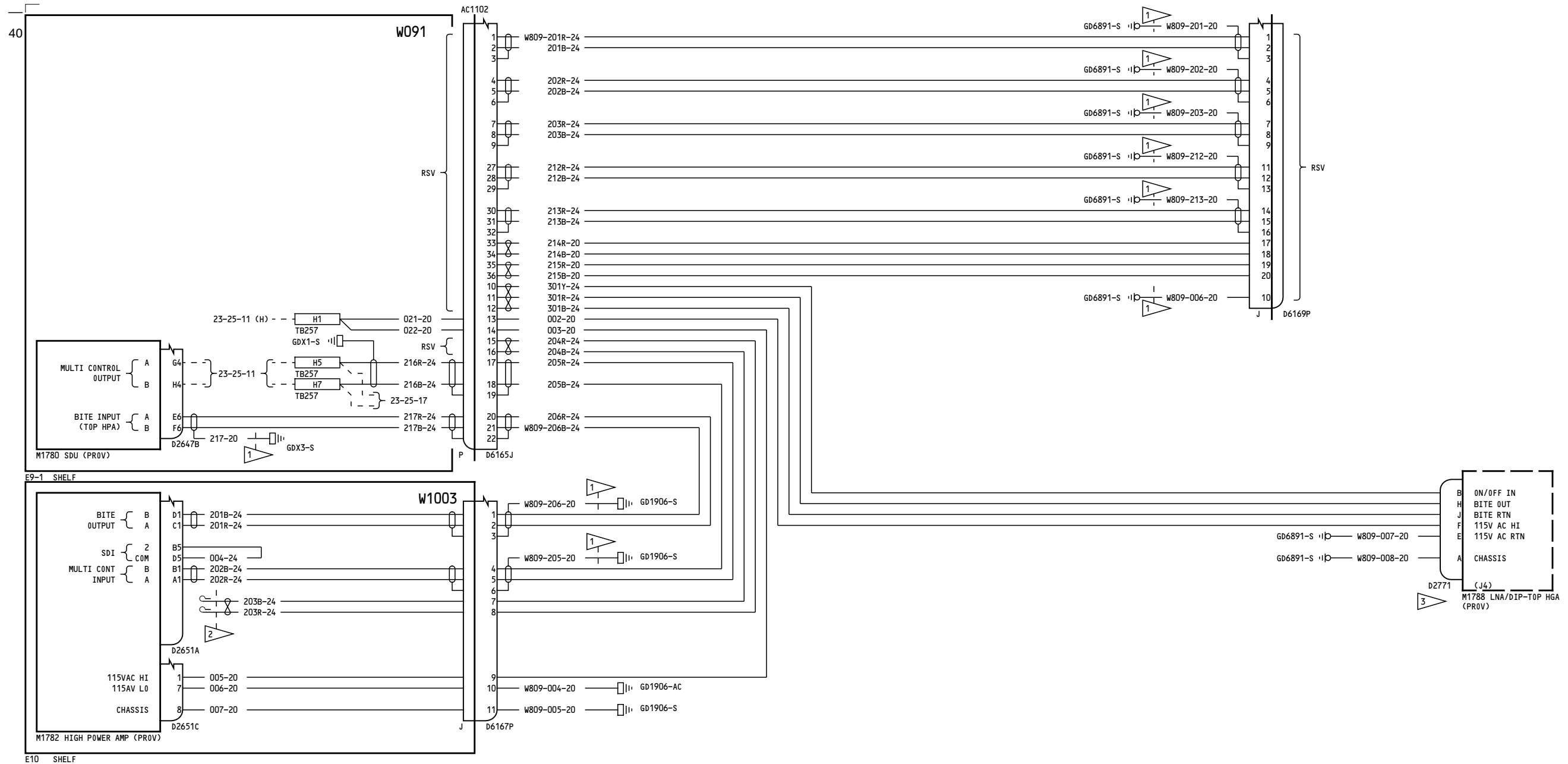

- NOTES:
- 1 MAX LENGTH OF GROUND WIRE SHALL NOT EXCEED 18 INCHES
 - 2 CAP & STOW NEAR D2651A
 - 3 CONNECTOR CAPPED AND STOWED

156-157, 166	SATCOM SYSTEM-TOP MOUNTED HGA SYSTEM	
	D280T132	

23-25-16
Page 2A
Jan 21/2005

Incorporates
MTO 230591

23-25-16
Page 2A
Jan 21/2005

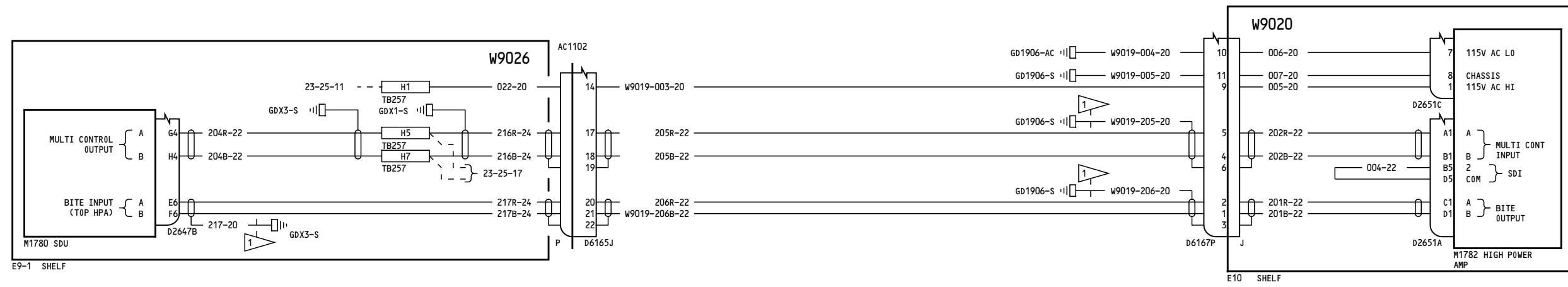

NOTES:
 1 MAX LENGTH OF GROUND WIRE SHALL NOT EXCEED 18 INCHES

162-165

**SATCOM SYSTEM-
 TOP MOUNTED HGA
 SYSTEM**

23-25-16

Page 3A

D280T132

Jan 21/2005

Incorporates
 MTO 230592

23-25-16

Page 3A

Jan 21/2005

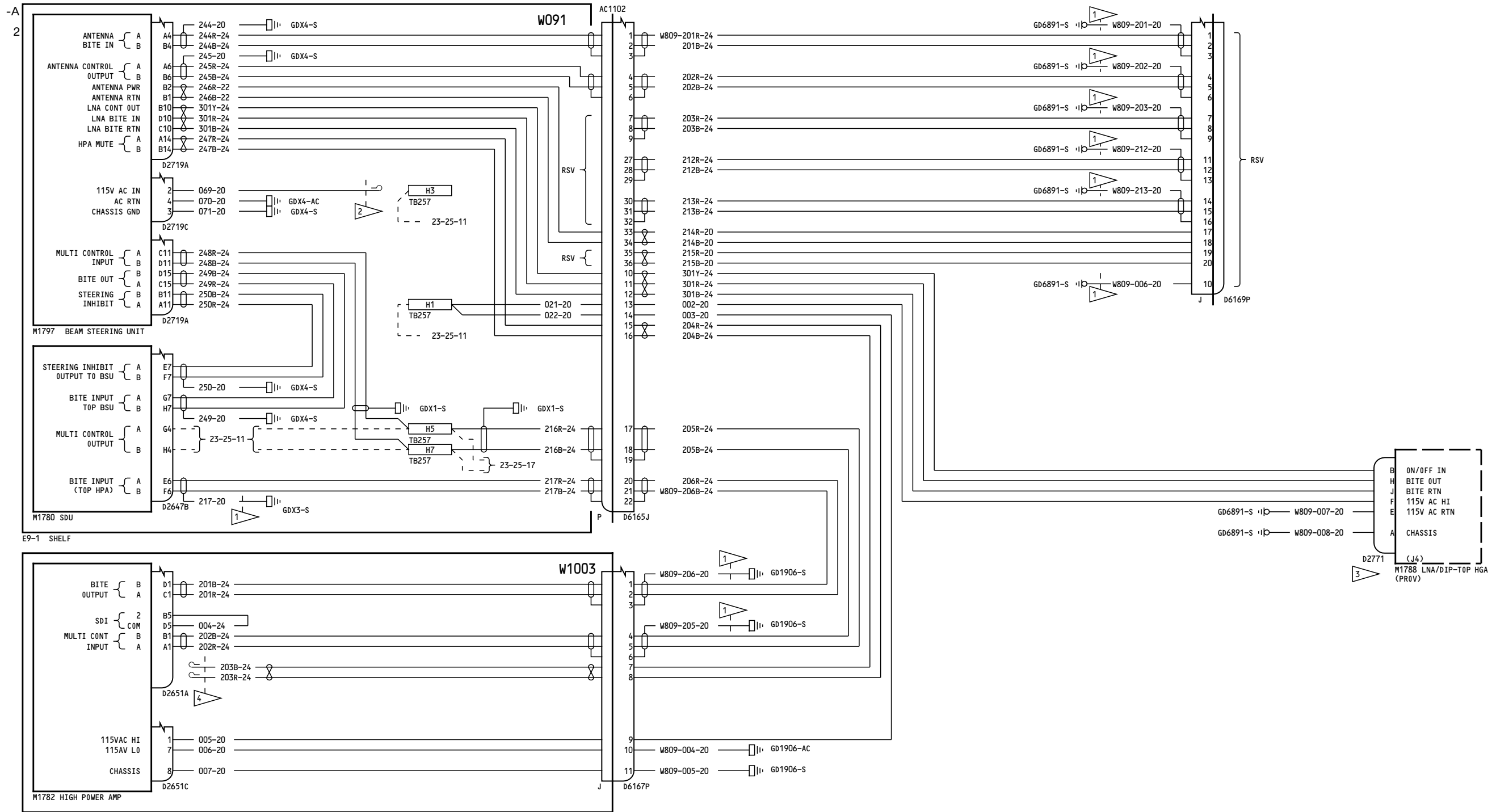

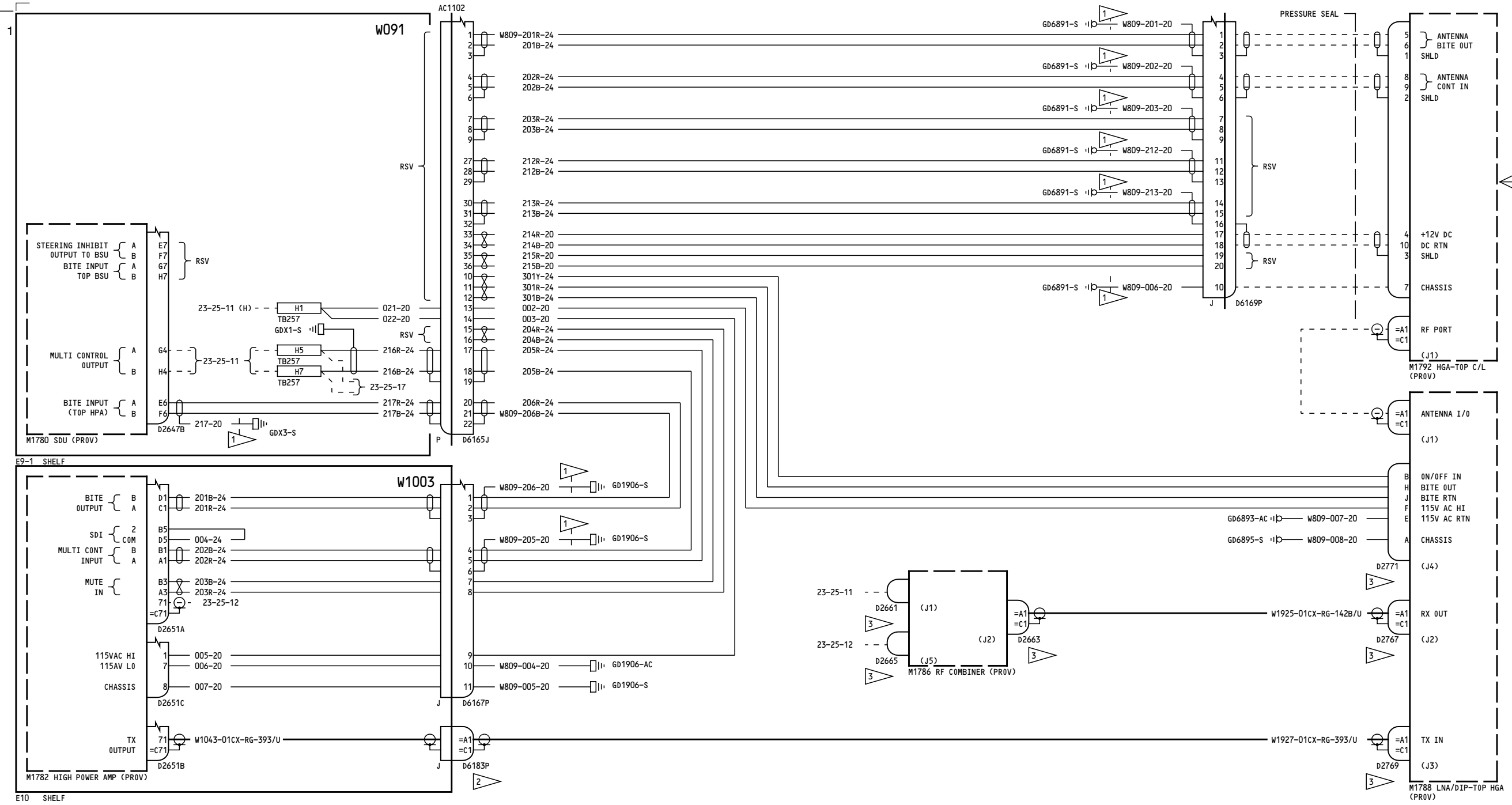

- NOTES:
- 1 MAX LENGTH OF GROUND WIRE SHALL NOT EXCEED 18 INCHES
 - 2 CONNECTOR CAPPED AND STOWED WHEN D6185P IS INSTALLED
 - 3 CONNECTOR CAPPED AND STOWED

277-299	SATCOM SYSTEM- TOP MOUNTED HGA SYSTEM	23-25-16
	D280T132	Page 5
		Jan 21/2005

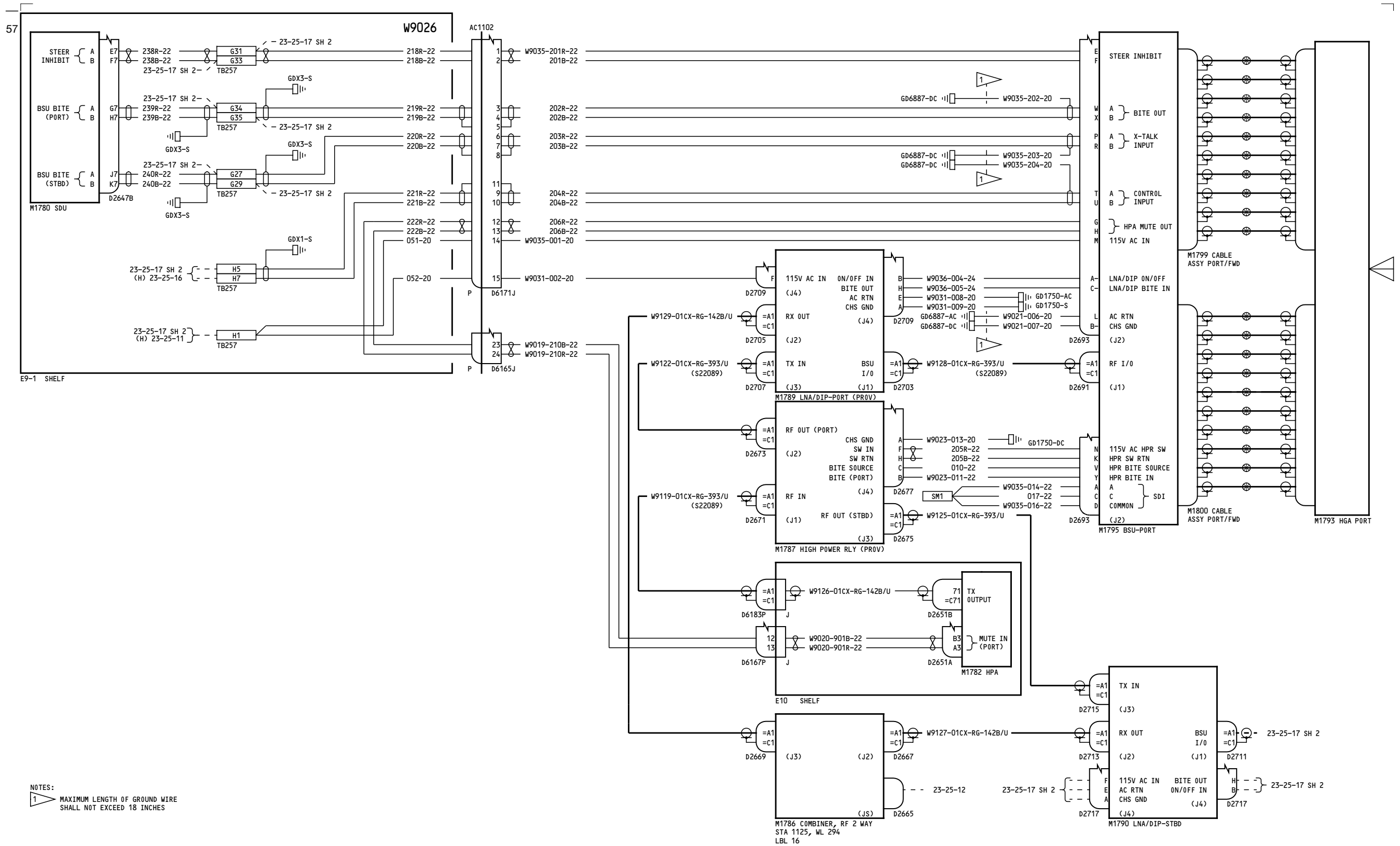

NOTES:
 1 MAXIMUM LENGTH OF GROUND WIRE SHALL NOT EXCEED 18 INCHES

150, 153-155

SATCOM SYSTEM-SIDE-MOUNTED HGA SUBSYSTEM

D280T132

23-25-17

Page 1A
 Sheet 1
 Jan 21/2005

Incorporates
 MTO 230593

23-25-17

Page 1A
 Sheet 1
 Jan 21/2005

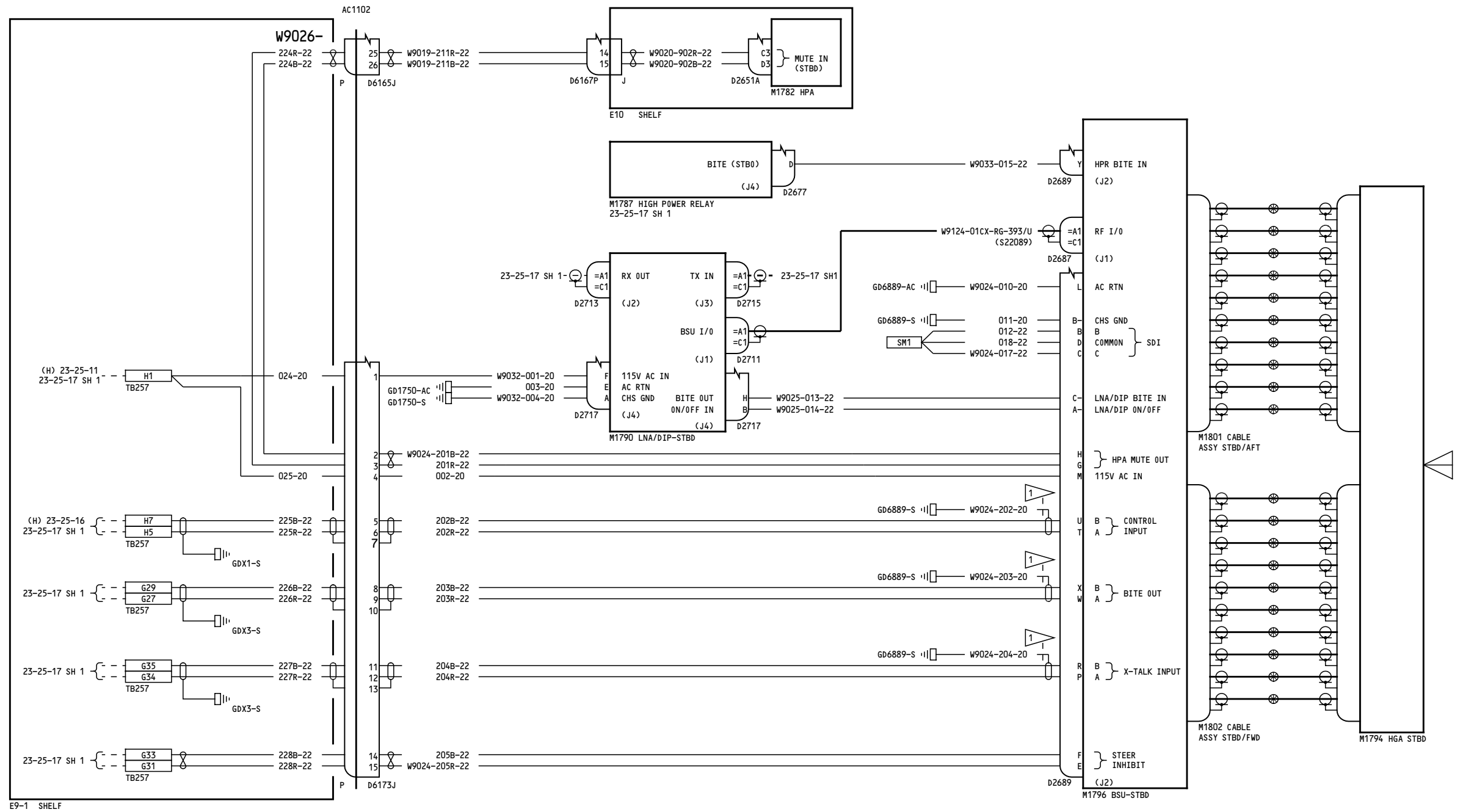

NOTES:
 1 MAXIMUM LENGTH OF GROUND WIRE SHALL NOT EXCEED 18 INCHES

150, 153-155

SATCOM SYSTEM-SIDE-MOUNTED HGA SUBSYSTEM

D280T132

23-25-17

Page 1A
 Sheet 2
 Jan 21/2005

Incorporates
 MTO 230593

23-25-17

Page 1A
 Sheet 2
 Jan 21/2005

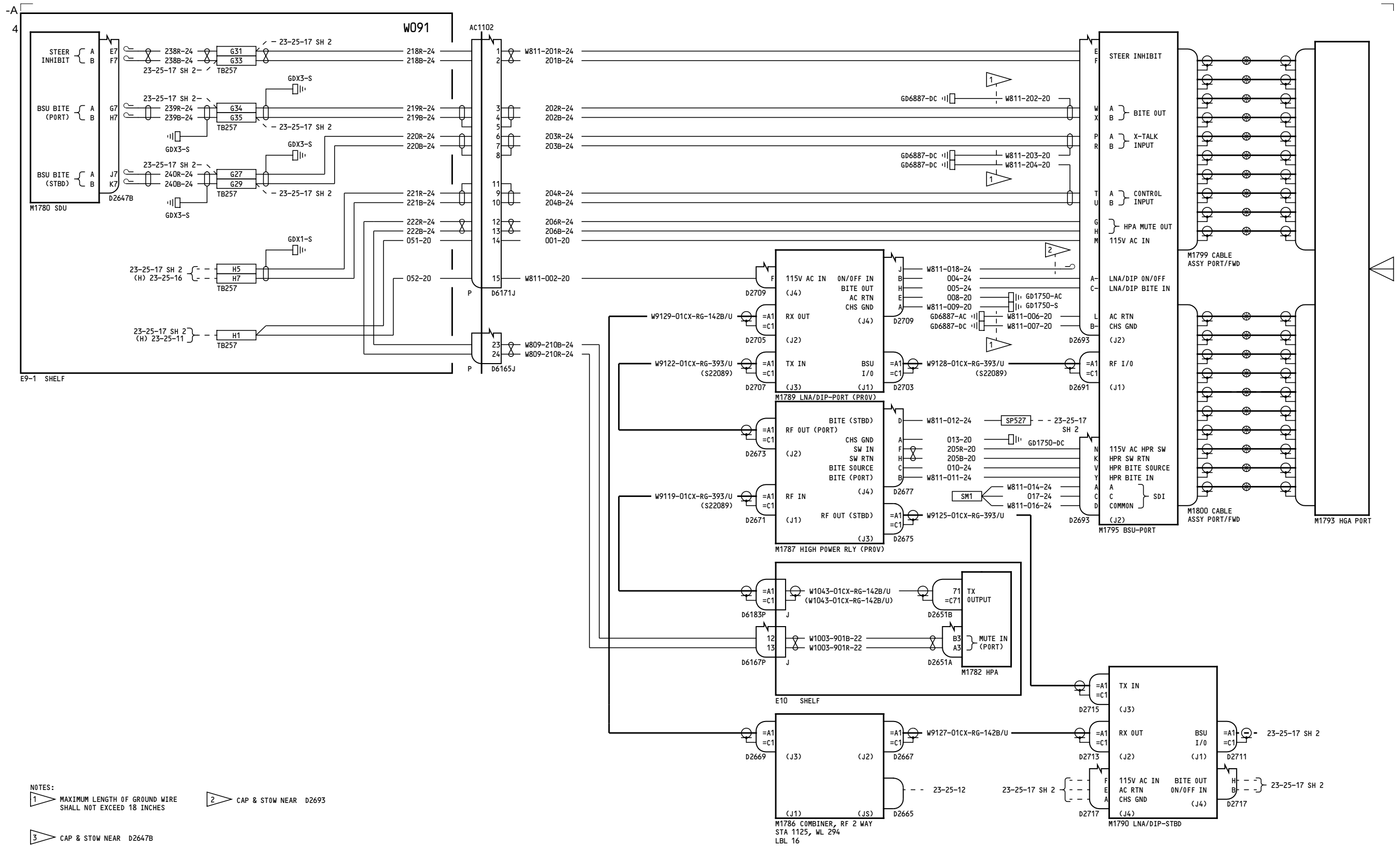

NOTES:
 1 MAXIMUM LENGTH OF GROUND WIRE SHALL NOT EXCEED 18 INCHES
 2 CAP & STOW NEAR D2693
 3 CAP & STOW NEAR D2647B

156-157, 166-167

SATCOM SYSTEM-SIDE-MOUNTED HGA SUBSYSTEM

D280T132

23-25-17

Page 2A
Sheet 1
Jan 21/2005

Incorporates
MTO 230591

23-25-17

Page 2A
Sheet 1
Jan 21/2005

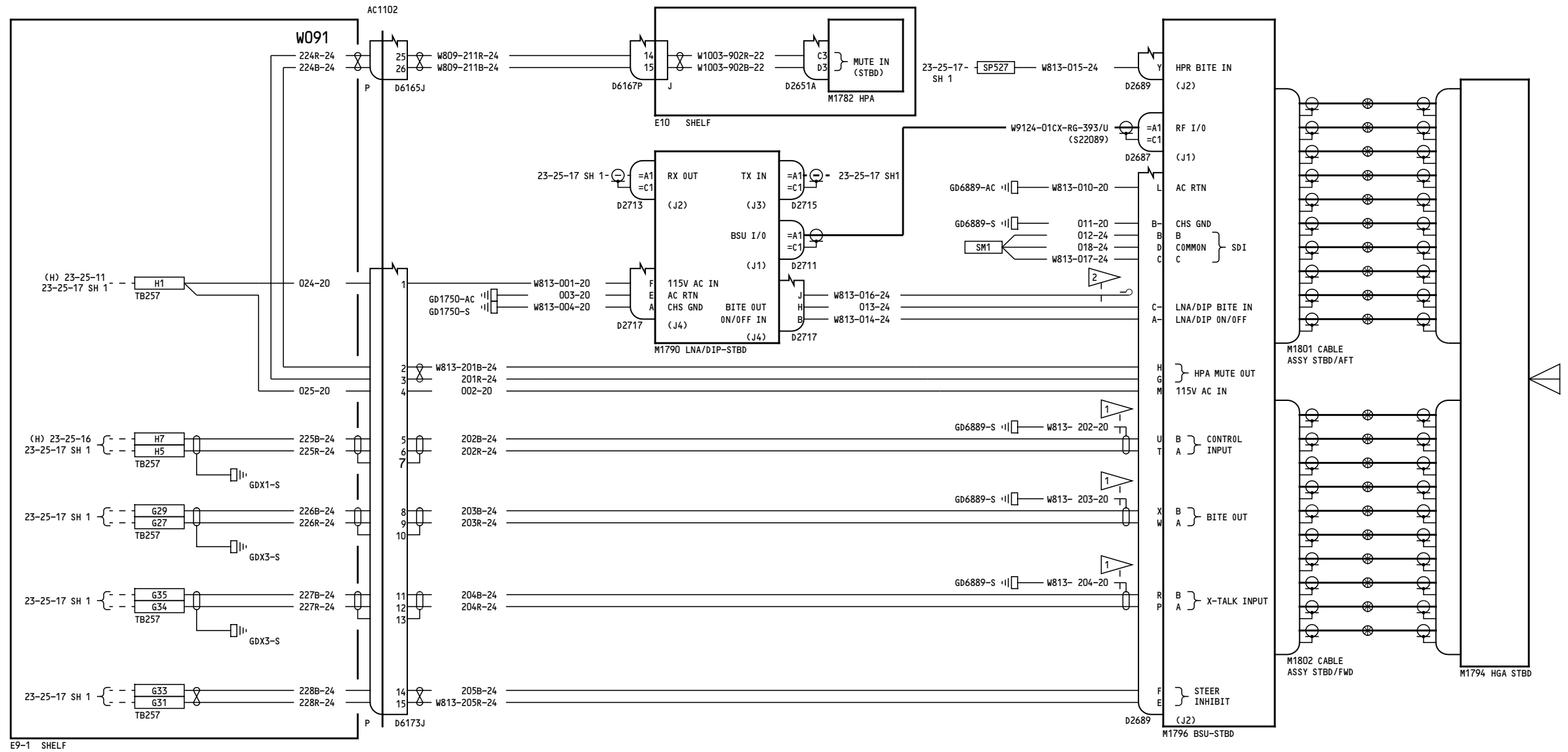

NOTES:
 1 MAXIMUM LENGTH OF GROUND WIRE SHALL NOT EXCEED 18 INCHES
 2 CAP & STOW NEAR D2689

156-157, 166-167

SATCOM SYSTEM-SIDE-MOUNTED HGA SUBSYSTEM

D280T132

23-25-17

Page 2A
 Sheet 2
 Jan 21/2005

Incorporates
 MTO 230591

23-25-17

Page 2A
 Sheet 2
 Jan 21/2005

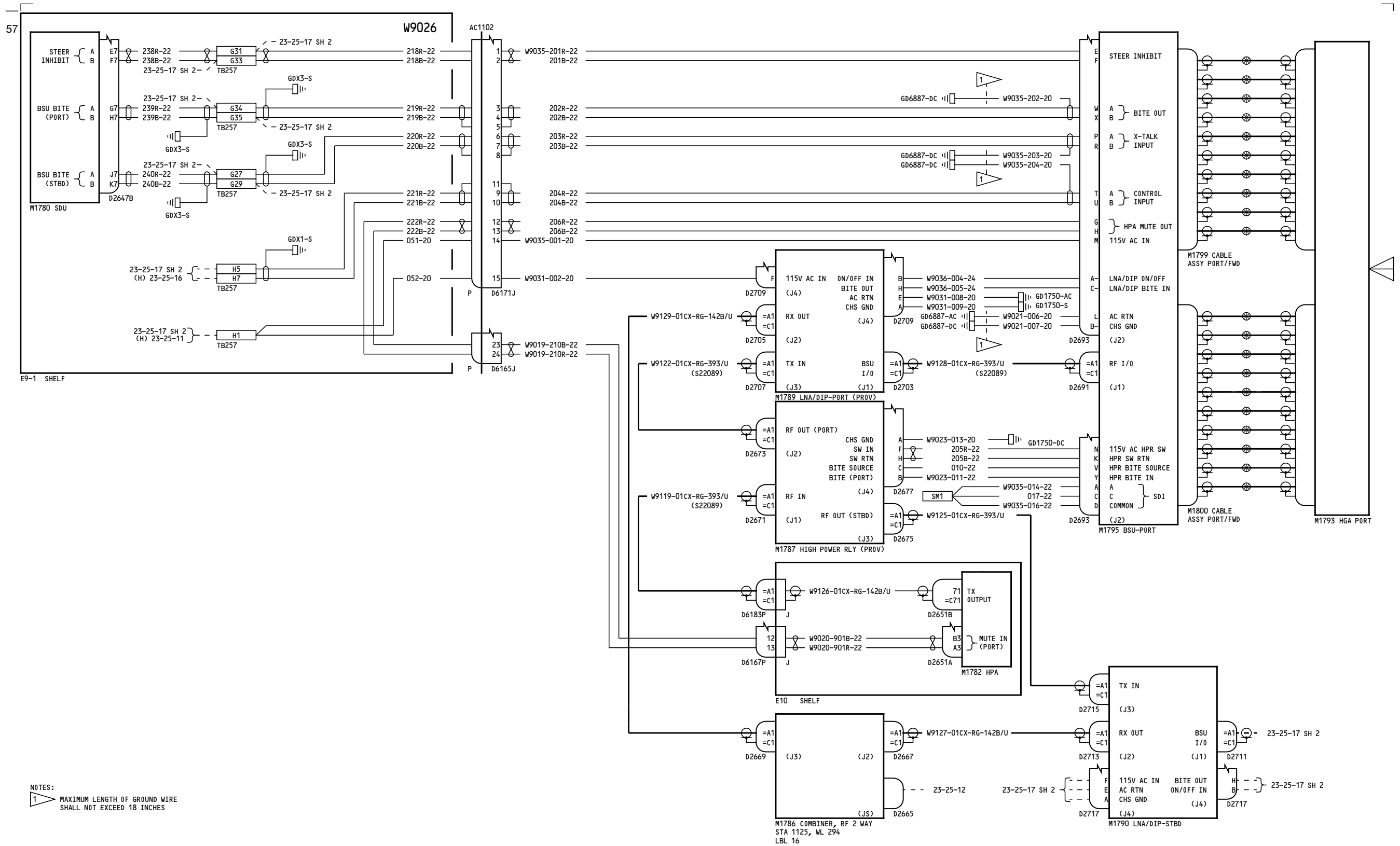

NOTES:
 1 MAXIMUM LENGTH OF GROUND WIRE SHALL NOT EXCEED 18 INCHES

162-165

SATCOM SYSTEM-SIDE-MOUNTED HGA SUBSYSTEM

D280T132

23-25-17

Page 3A
 Sheet 1
 Jan 21/2005

Incorporates
 MTO 230592

23-25-17

Page 3A
 Sheet 1
 Jan 21/2005

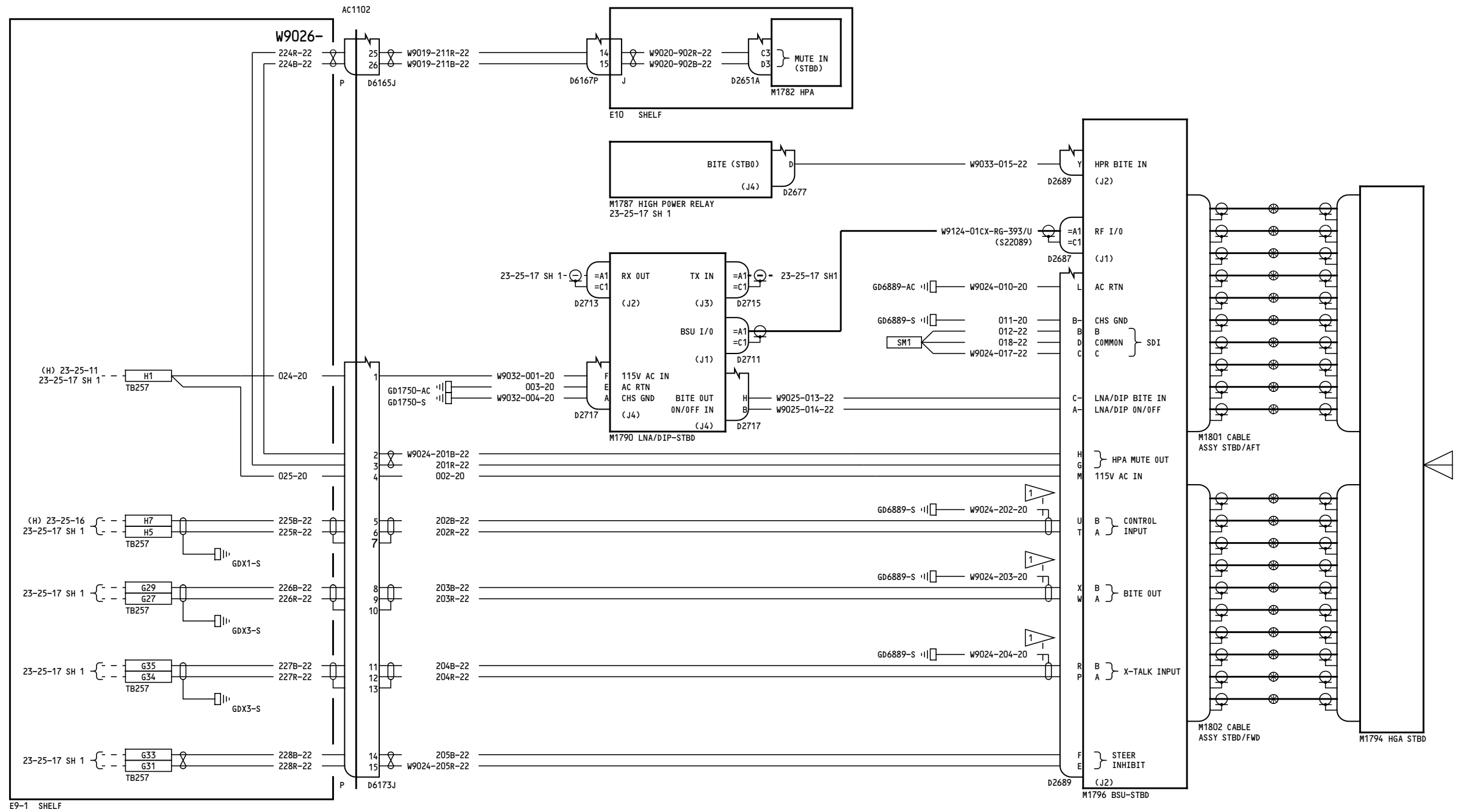

NOTES:
 1 MAXIMUM LENGTH OF GROUND WIRE SHALL NOT EXCEED 18 INCHES

162-165

SATCOM SYSTEM-SIDE-MOUNTED HGA SUBSYSTEM

D280T132

23-25-17

Page 3A
 Sheet 2
 Jan 21/2005

Incorporates
 MTO 230592

23-25-17

Page 3A
 Sheet 2
 Jan 21/2005

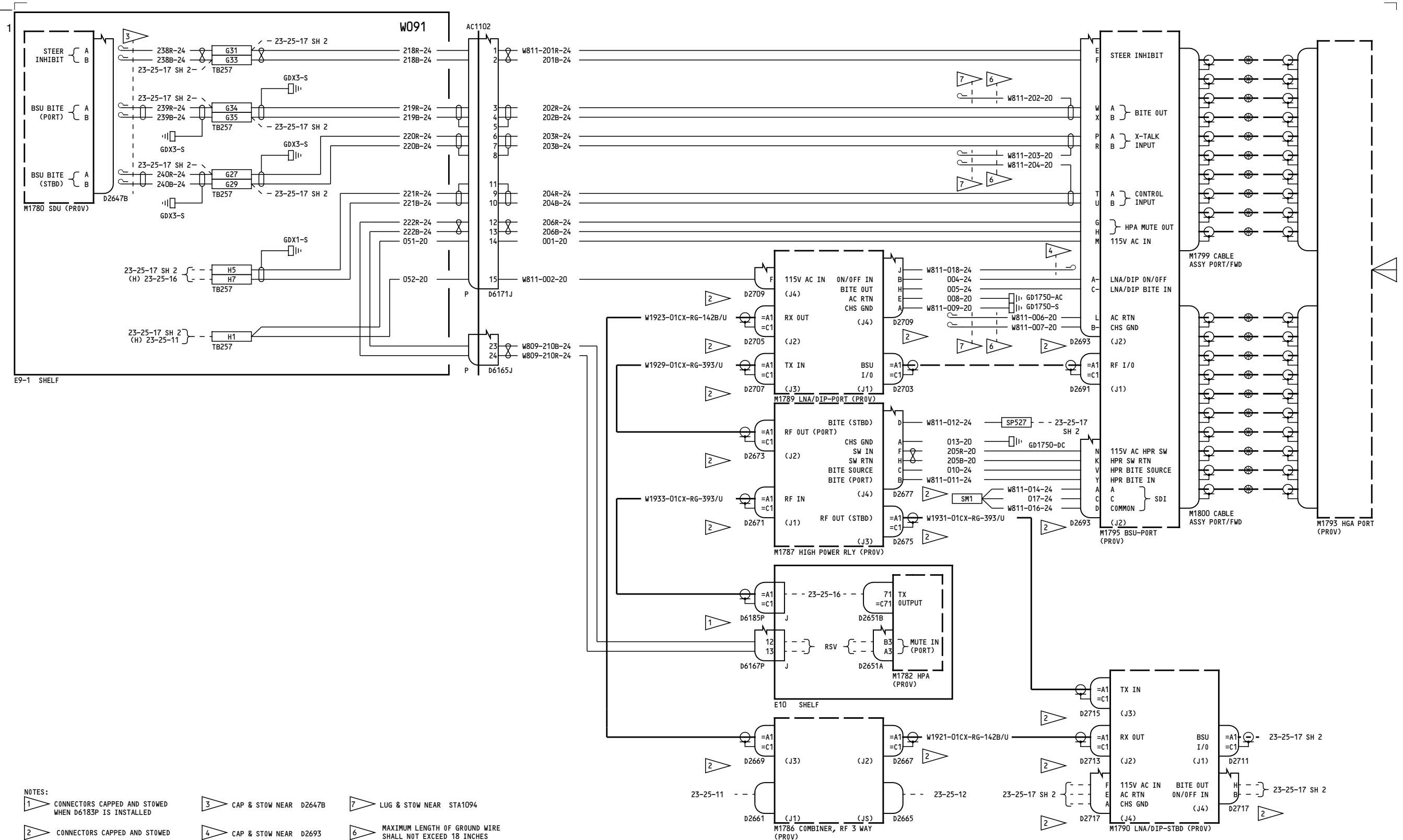

- NOTES:
- 1 CONNECTORS CAPPED AND STOWED WHEN D6183P IS INSTALLED
 - 2 CONNECTORS CAPPED AND STOWED
 - 3 CAP & STOW NEAR D2647B
 - 4 CAP & STOW NEAR D2693
 - 5 LUG & STOW NEAR STA1094
 - 6 MAXIMUM LENGTH OF GROUND WIRE SHALL NOT EXCEED 18 INCHES

277-299

SATCOM SYSTEM-SIDE-MOUNTED HGA SUBSYSTEM

D280T132

23-25-17

Page 4
Sheet 1
Jan 21/2005

23-25-17

Page 4
Sheet 1
Jan 21/2005

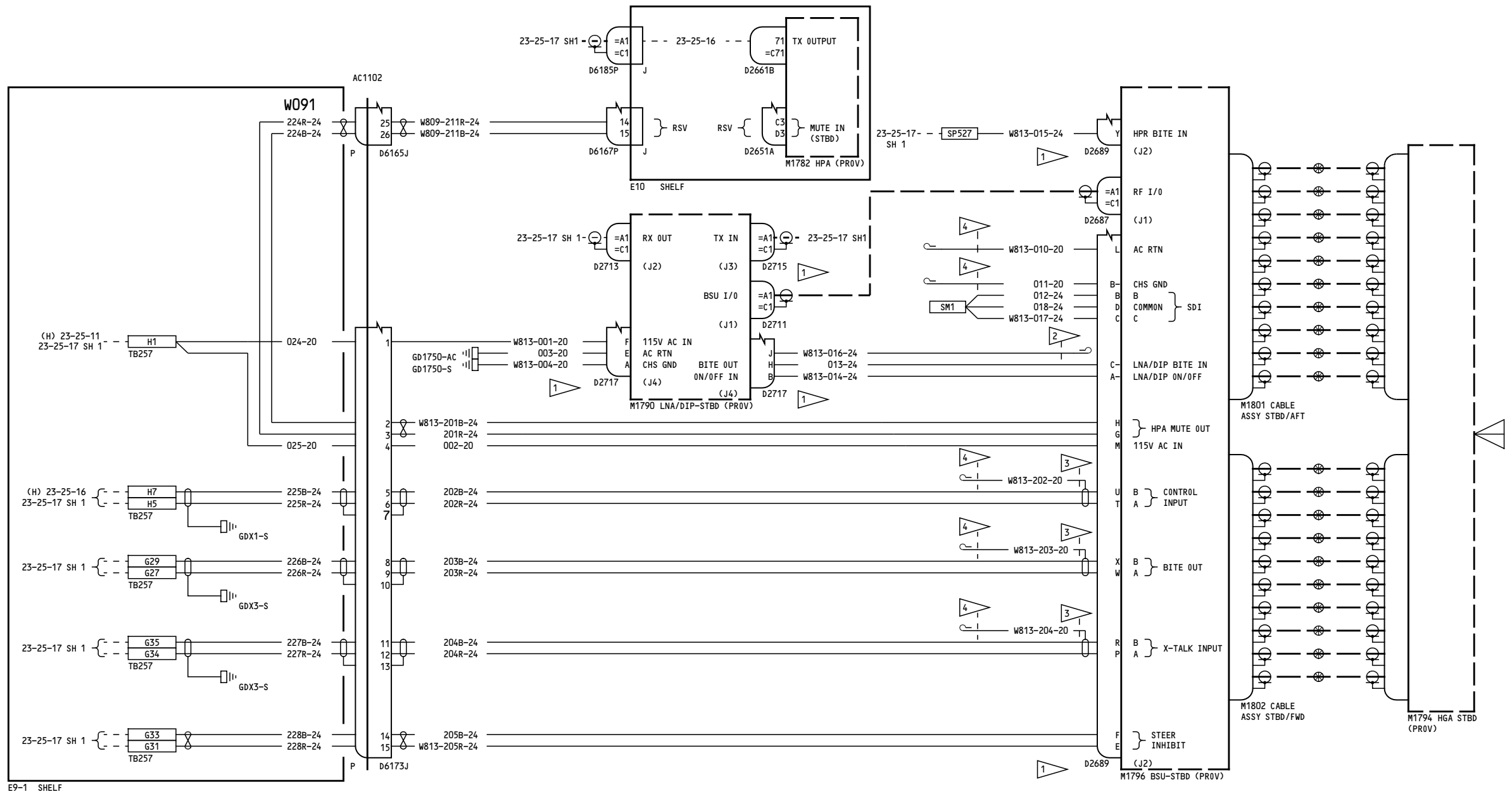

- NOTES:
- 1 CONNECTORS CAPPED AND STOWED
 - 2 CAP & STOW NEAR D2689
 - 3 MAXIMUM LENGTH OF GROUND WIRE SHALL NOT EXCEED 18 INCHES
 - 4 LUG & STOW NEAR STA1109

277-299

SATCOM SYSTEM-SIDE-MOUNTED HGA SUBSYSTEM

D280T132

23-25-17

Page 4
 Sheet 2
 Jan 21/2005

23-25-17

Page 4
 Sheet 2
 Jan 21/2005

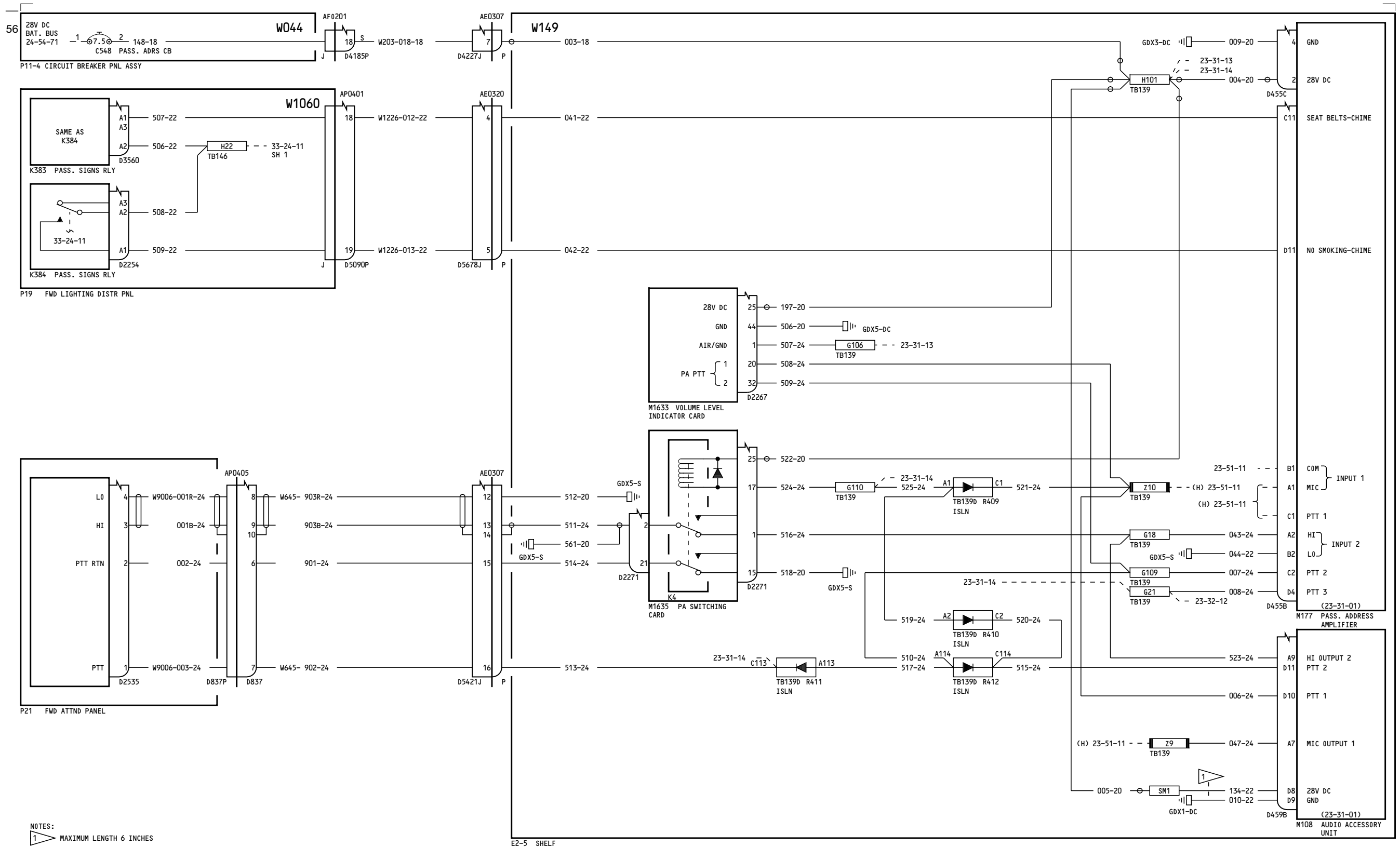

050-051

**PASSENGER ADDRESS-
VOICE INPUT
CIRCUITRY**

23-31-11

Page 1A

Jan 21/2005

D280T132

Incorporates
▶ MTO 230452A
▶ MTO 230540

23-31-11

Page 1A

Jan 21/2005

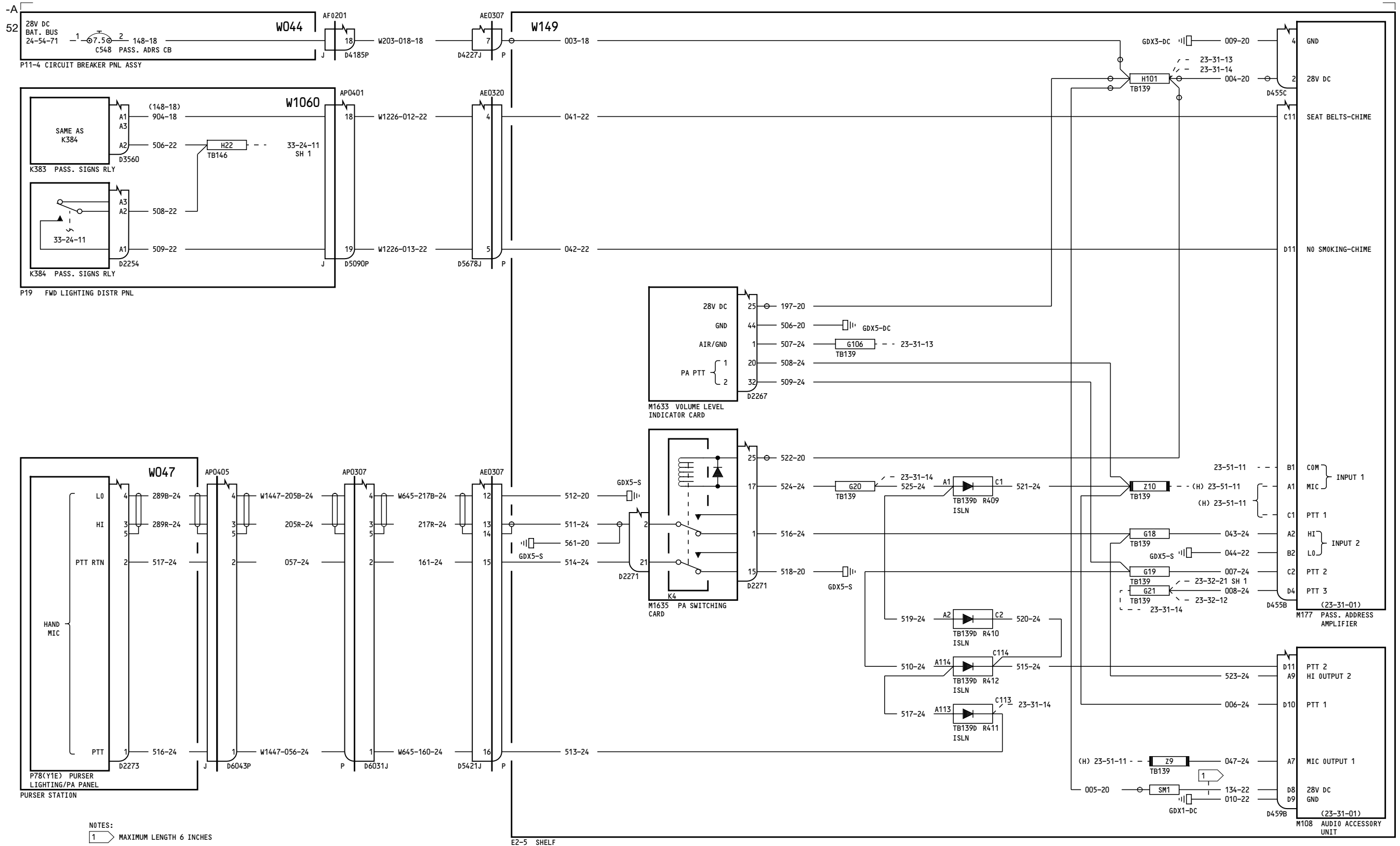

NOTES:
 1 MAXIMUM LENGTH 6 INCHES

150, 152

PASSENGER ADDRESS-VOICE INPUT CIRCUITRY

D280T132

23-31-11

Page 2.1A
 Jan 21/2005

- Incorporates
- 23-0032 R01
- MTO 230452A
- MTO-230718

23-31-11

Page 2.1A
 Jan 21/2005

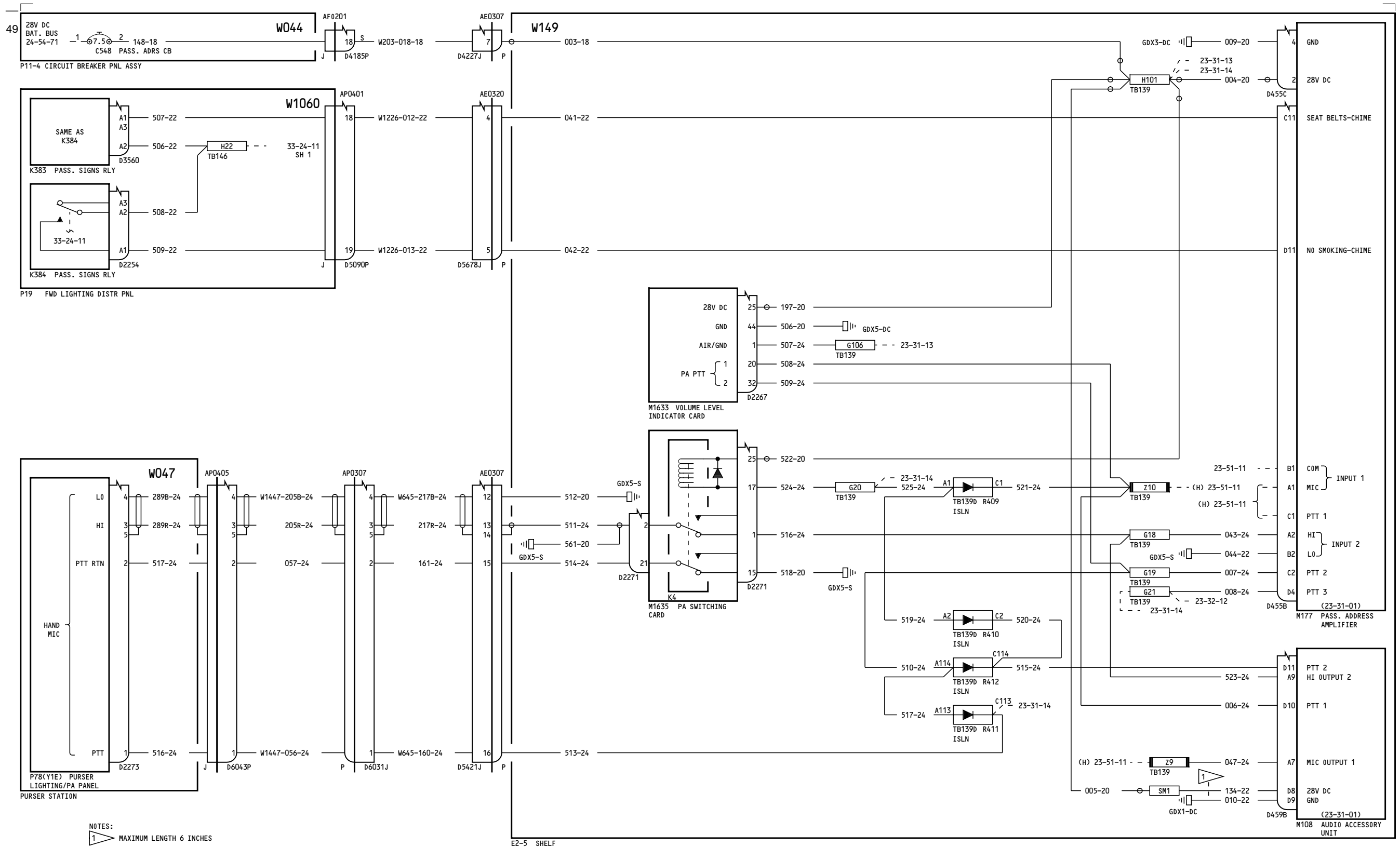

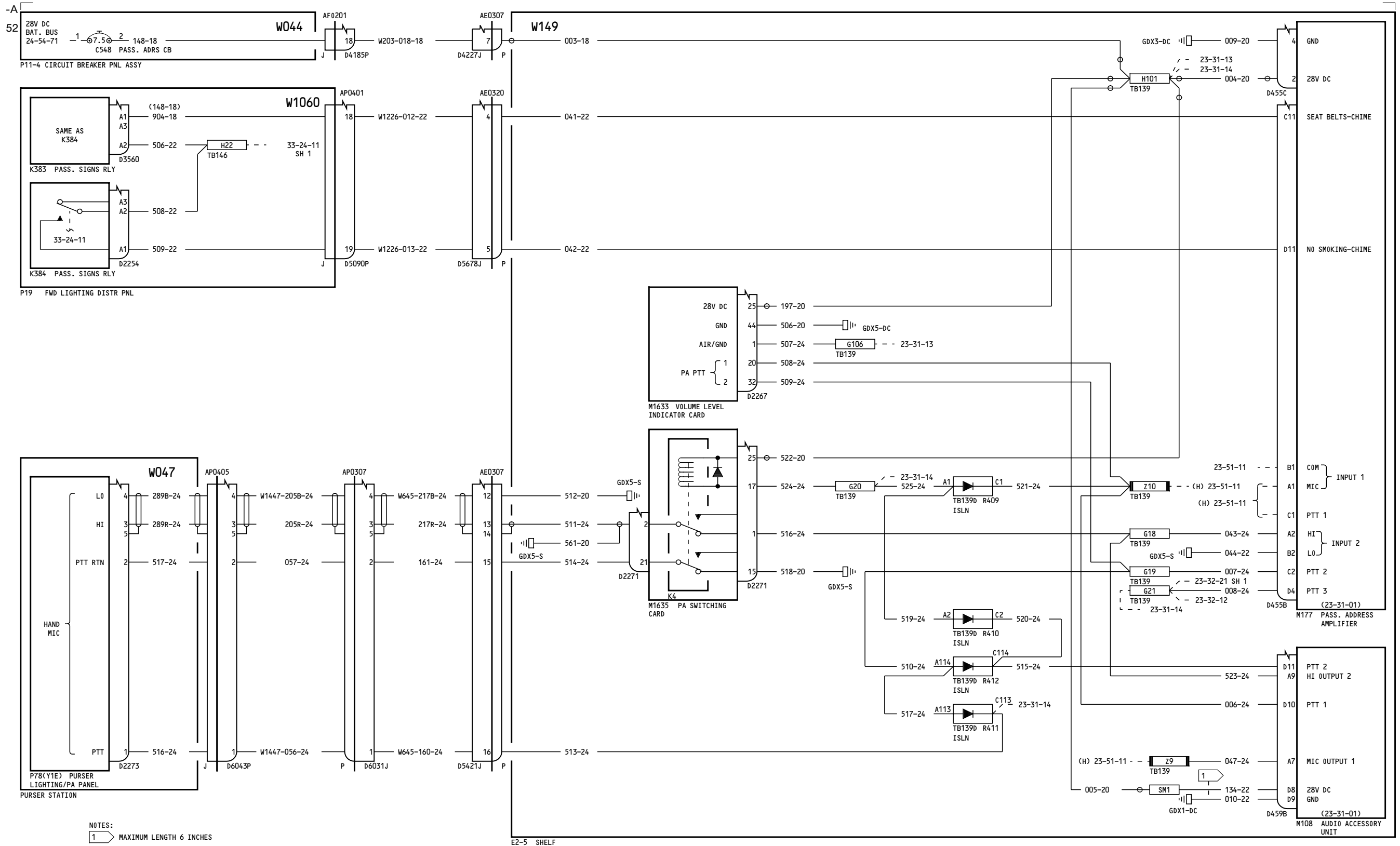

153-154

PASSENGER ADDRESS-VOICE INPUT CIRCUITRY

D280T132

23-31-11

Page 4.1A
 Jan 21/2005

- Incorporates
- ▶ 23-0041
 - ▶ MTO 230452A
 - ▶ MTO-230718

23-31-11

Page 4.1A
 Jan 21/2005

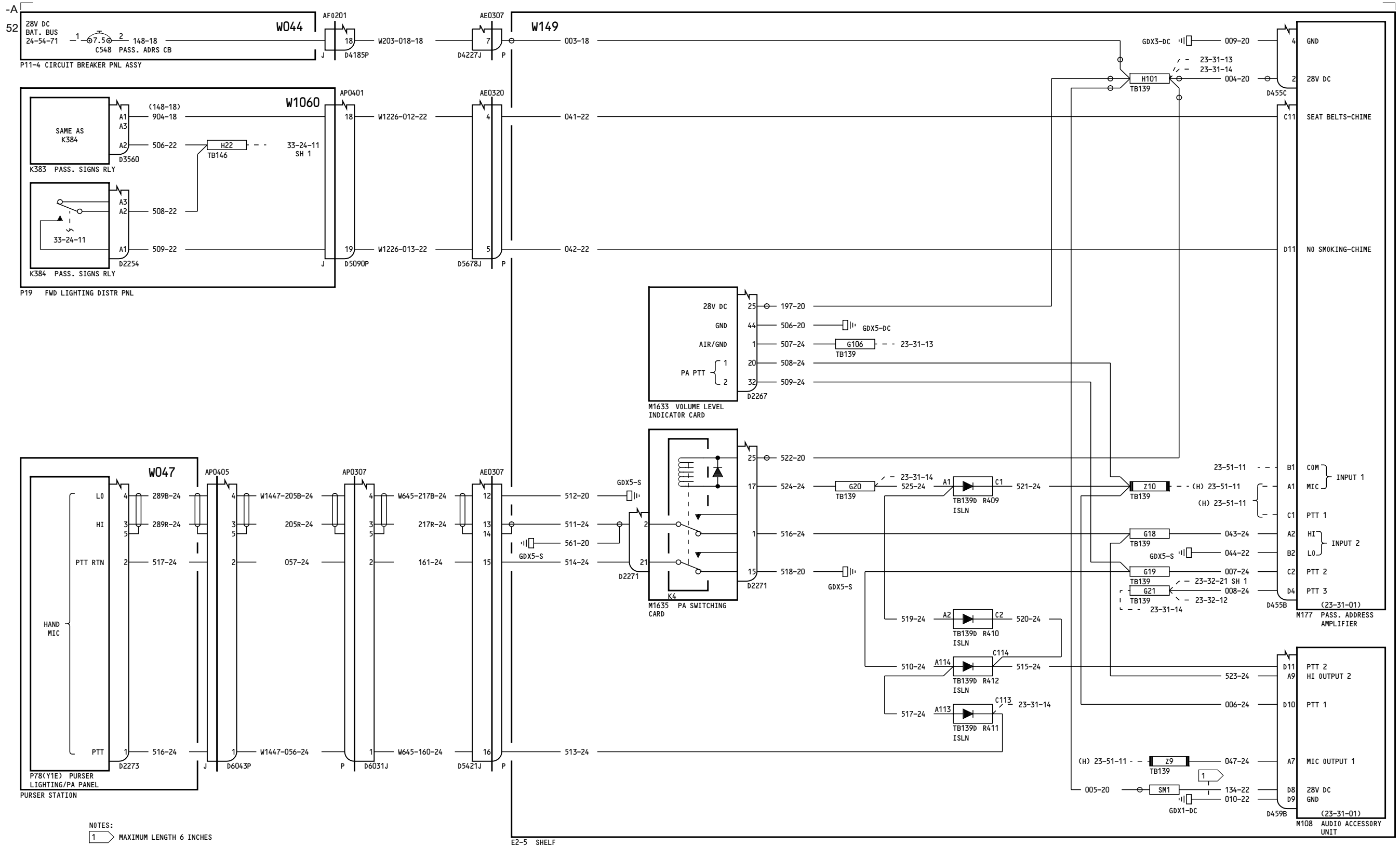

NOTES:
 1 MAXIMUM LENGTH 6 INCHES

155-167

PASSENGER ADDRESS-VOICE INPUT CIRCUITRY

D280T132

23-31-11

Page 5A

Jan 21/2005

Incorporates
 MTO 230452A
 MTO-230718

23-31-11

Page 5A

Jan 21/2005

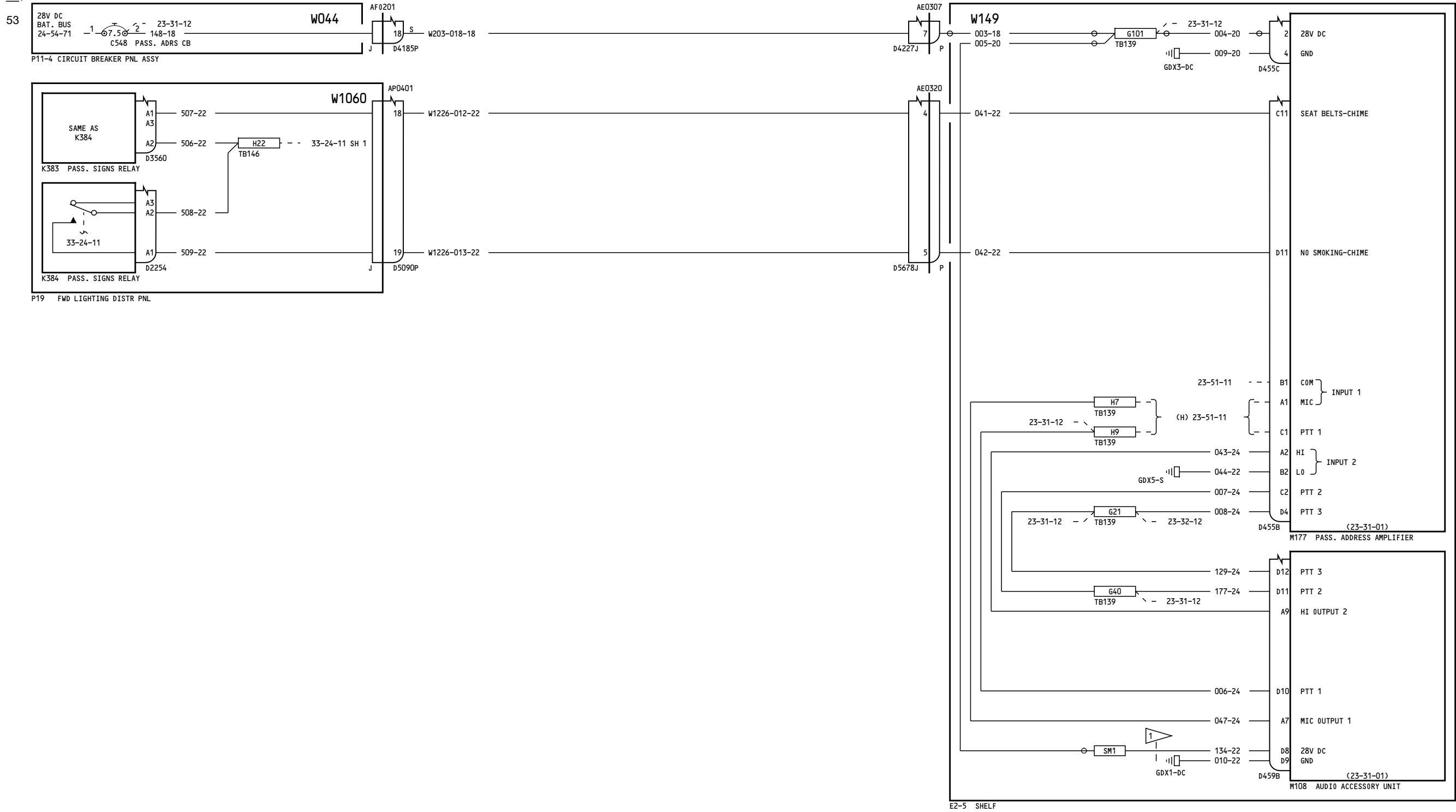

NOTES:
 1 MAX LENGTH 6 INCHES

275	PASSENGER ADDRESS-VOICE INPUT CIRCUITRY
	D280T132

23-31-11
 Page 6.1
 Jan 21/2005

Incorporates
 23-0041

23-31-11
 Page 6.1
 Jan 21/2005

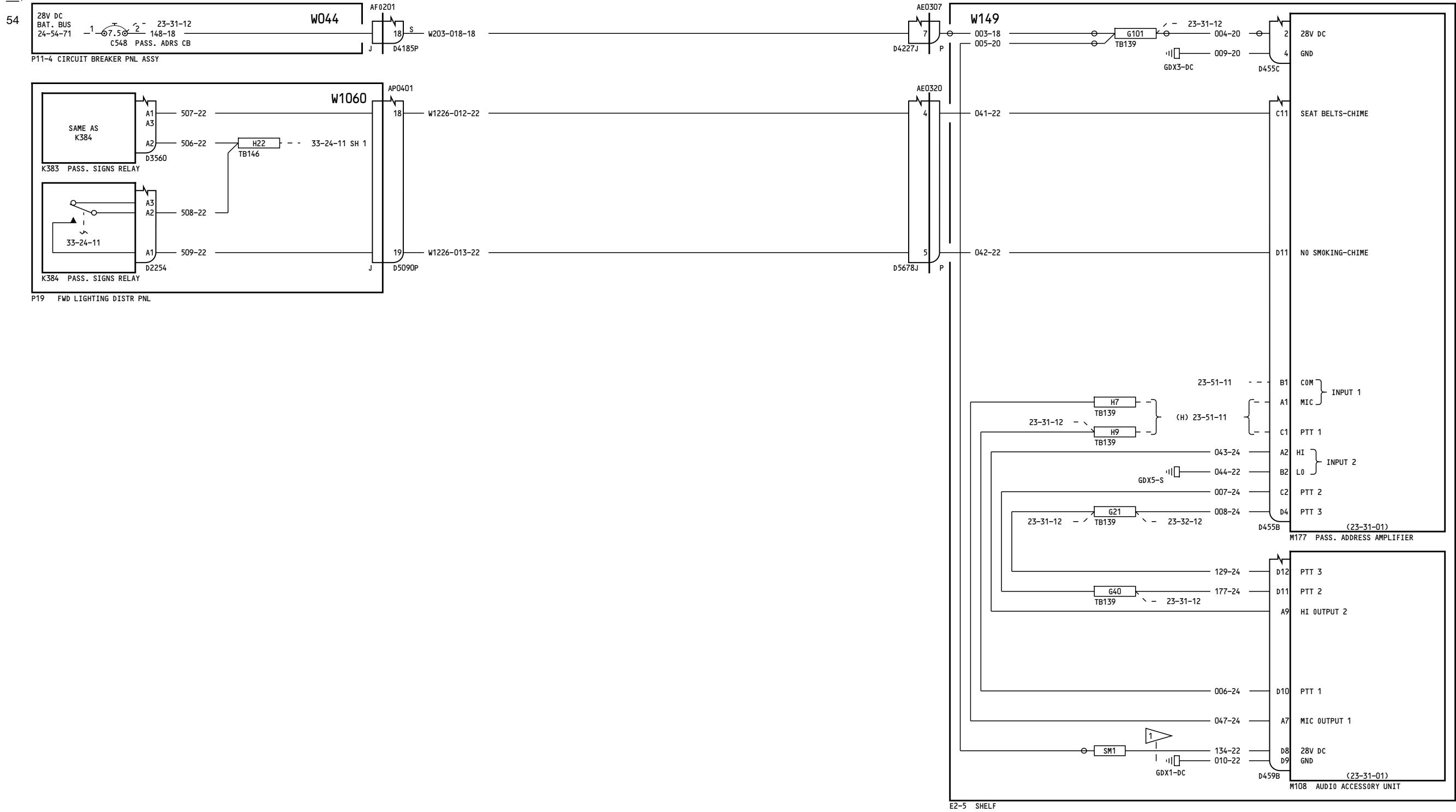

NOTES:
 MAX LENGTH 6 INCHES

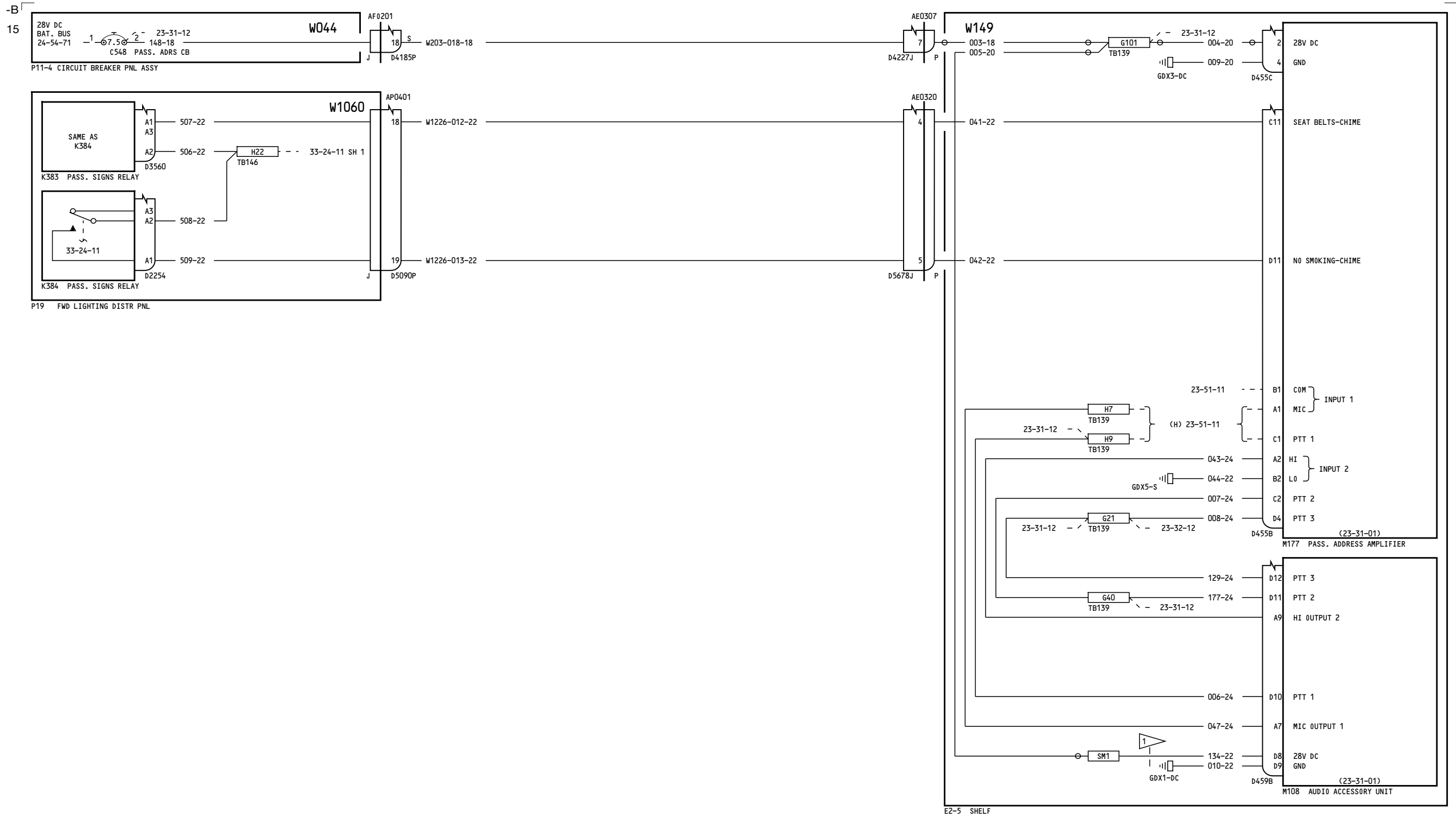

NOTES:
 MAX LENGTH 6 INCHES

277-278	<p align="center">PASSENGER ADDRESS-VOICE INPUT CIRCUITRY</p> <p align="center">D280T132</p>
---------	-----------------------------------------------------------------------------------------------------

23-31-11

Page 8

Jan 21/2005

23-31-11

Page 8

Jan 21/2005

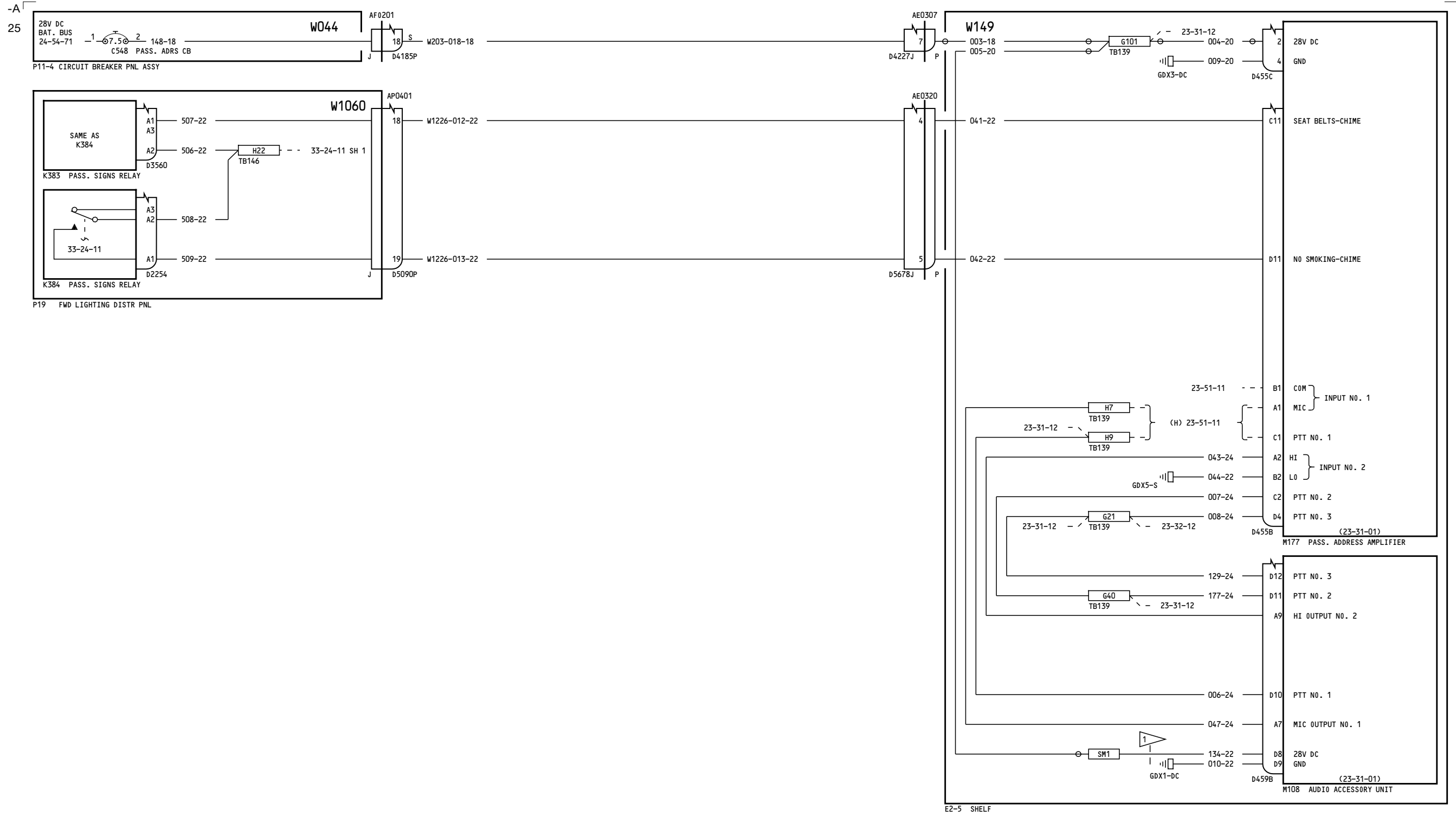

NOTES:
 MAX LENGTH 6 INCHES

280-299	<p align="center">PASSENGER ADDRESS-VOICE INPUT CIRCUITRY</p> <p align="center">D280T132</p>
---------	-----------------------------------------------------------------------------------------------------

23-31-11

23-31-11

116

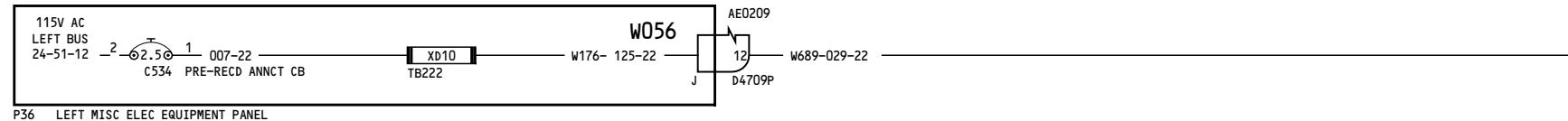

P36 LEFT MISC ELEC EQUIPMENT PANEL

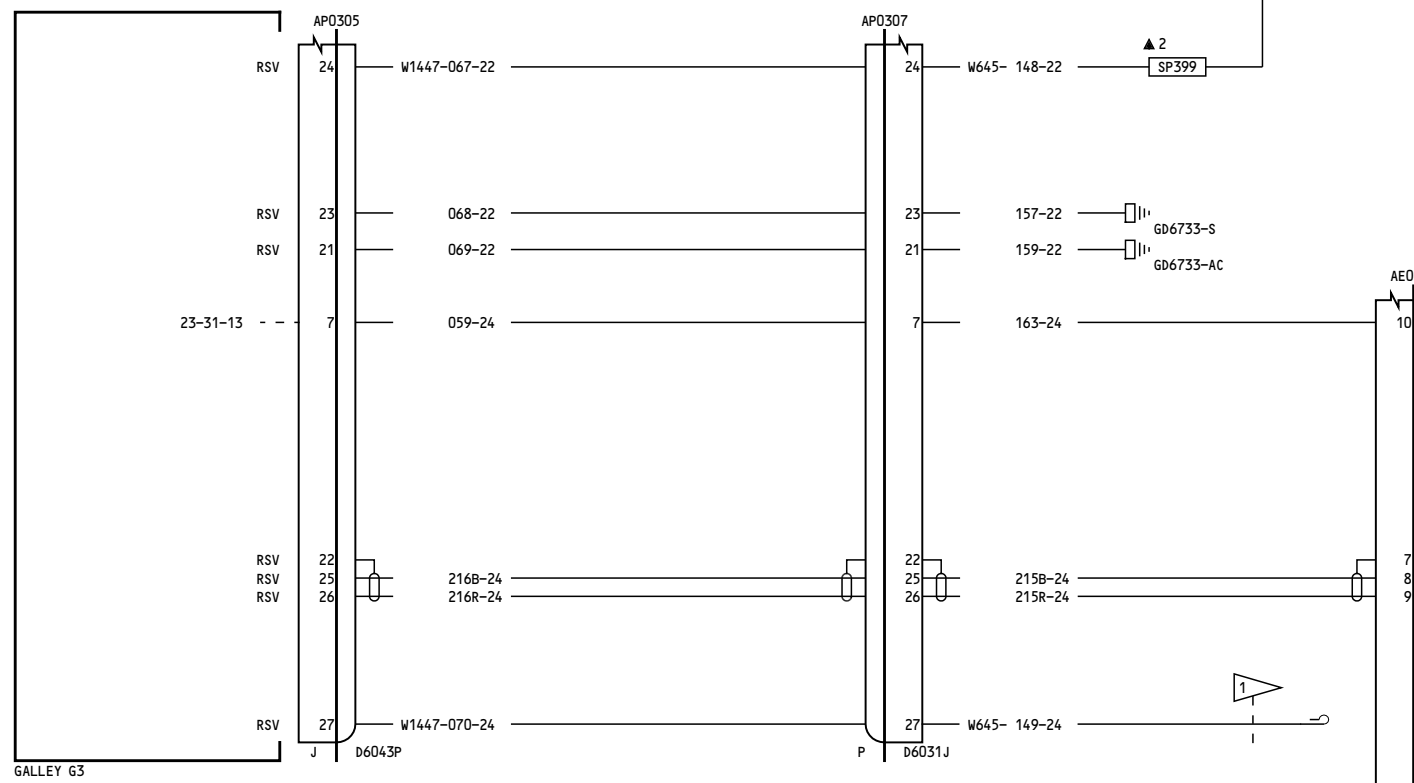

GALLEY G3

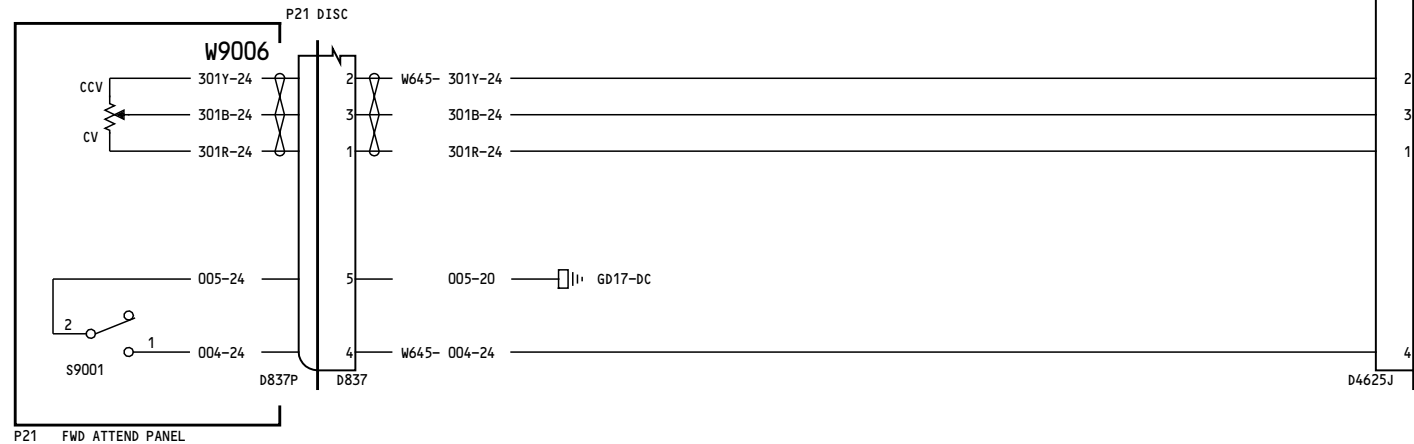

P21 FWD ATTEND PANEL

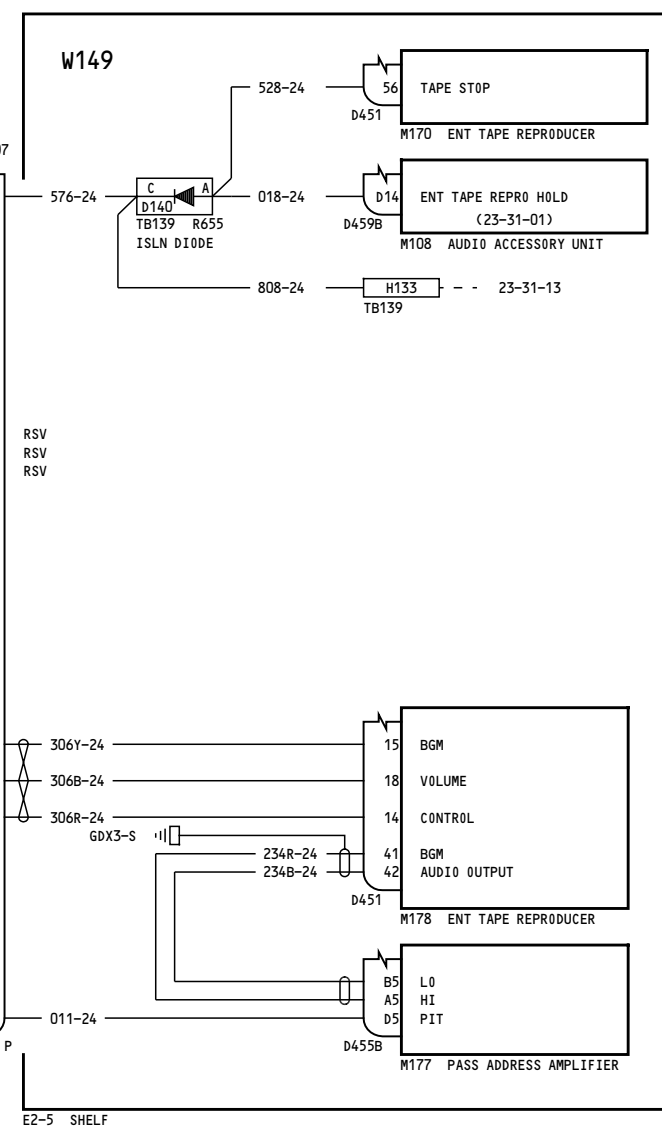

E2-5 SHELF

1 CAP & STOW NEAR D4625J

050-051

PASSENGER ADDRESS-BOARDING MUSIC/PRE-RECORD ANN. & ATTEND. PANEL

D280T132

23-31-12

Page 1A
Jan 21/2005

Incorporates
MTO 230540

23-31-12

Page 1A
Jan 21/2005

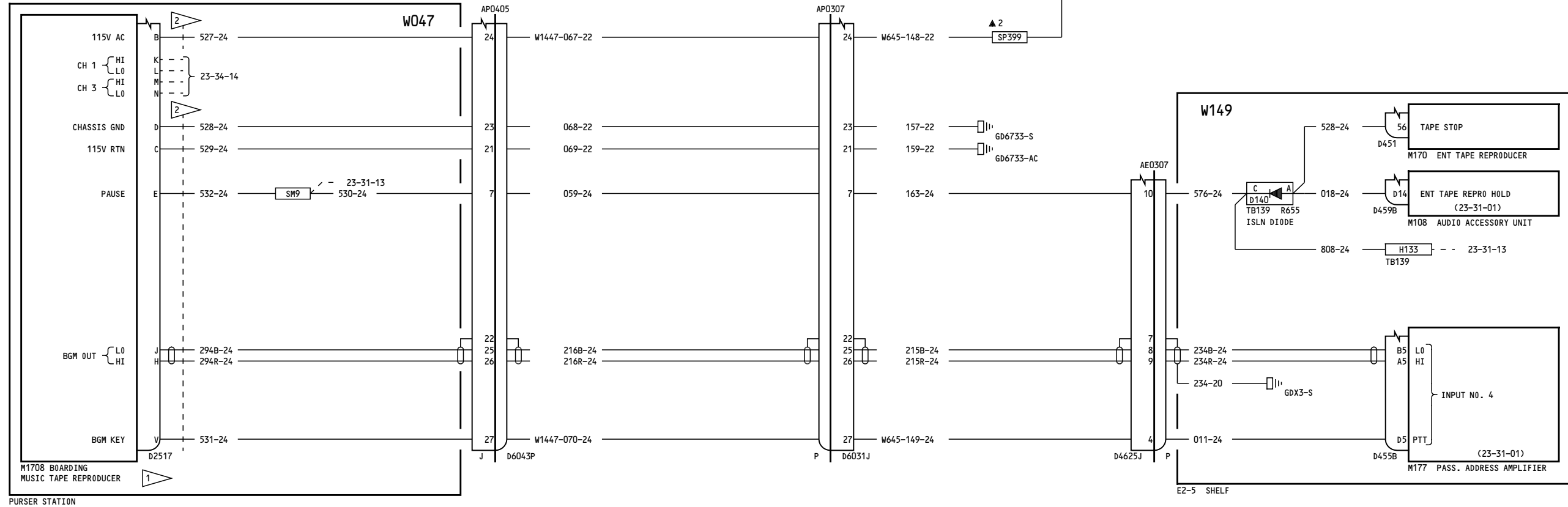
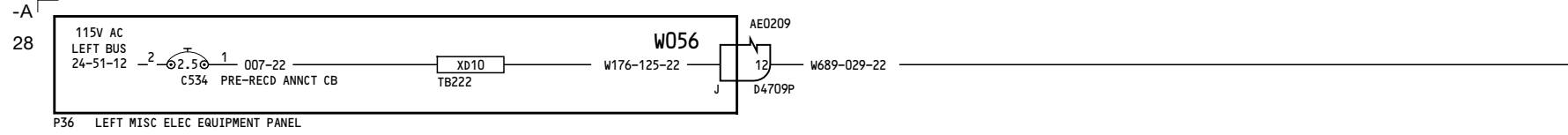

- NOTES:
- 1 CAP & STOW CONNECTOR AND M1708 BECOMES PROVISIONAL FOR VN151-VN151 (150-150)
 - 2 CAP & STOW WIRES AT D2517 FOR VN151-VN151 (150-150)

150-199

PASSENGER ADDRESS-BOARDING MUSIC/PRE-RECORD ANN. & ATTEND. PANEL

23-31-12

Page 2

Jan 21/2005

D280T132

23-31-12

Page 2

Jan 21/2005

33

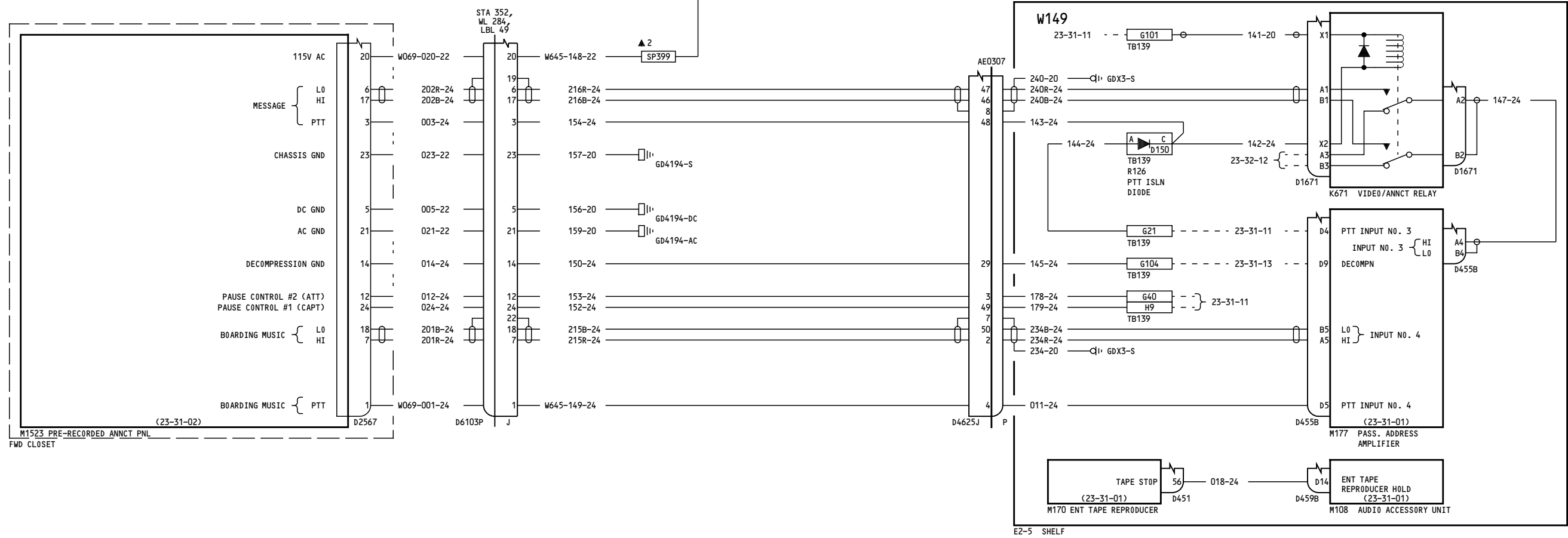
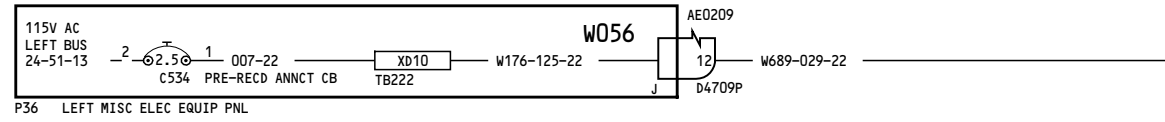

275-278

PASSENGER ADDRESS-BOARDING MUSIC/PRE-RECORD ANN. & ATTEND. PANEL

23-31-12

Page 3

Jan 21/2005

D280T132

23-31-12

Page 3

Jan 21/2005

48

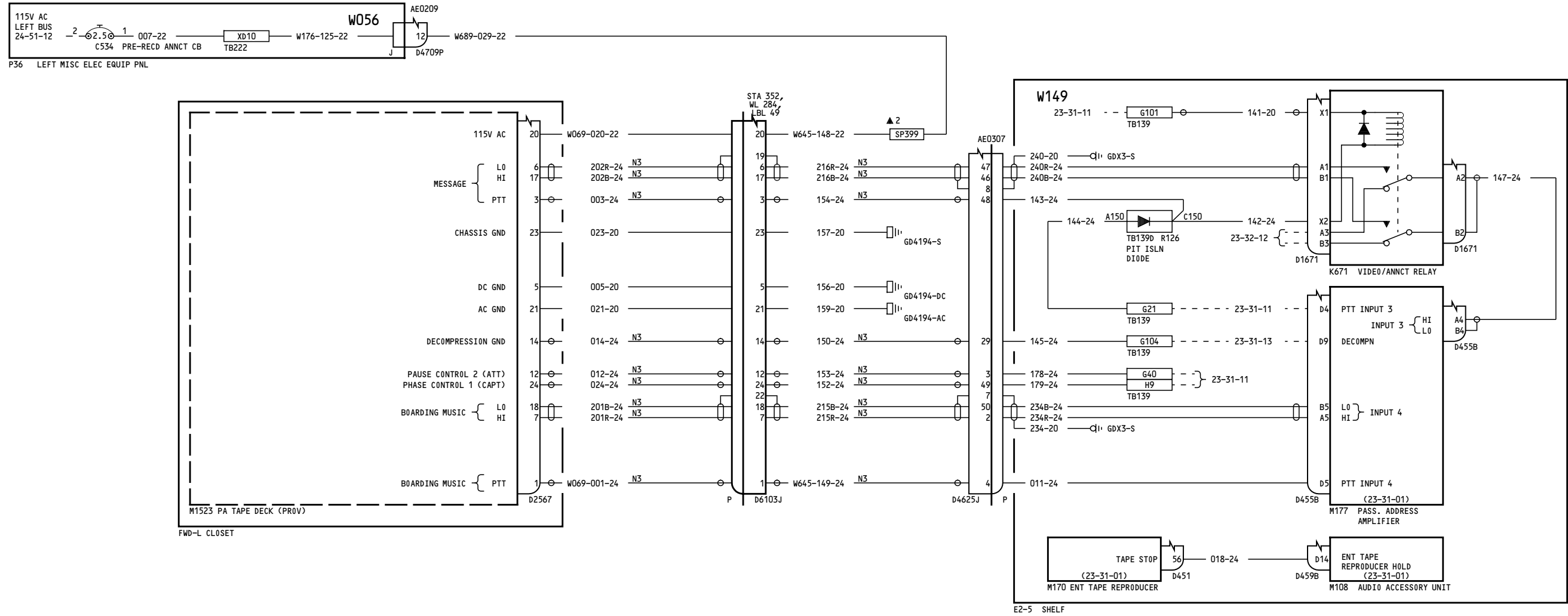

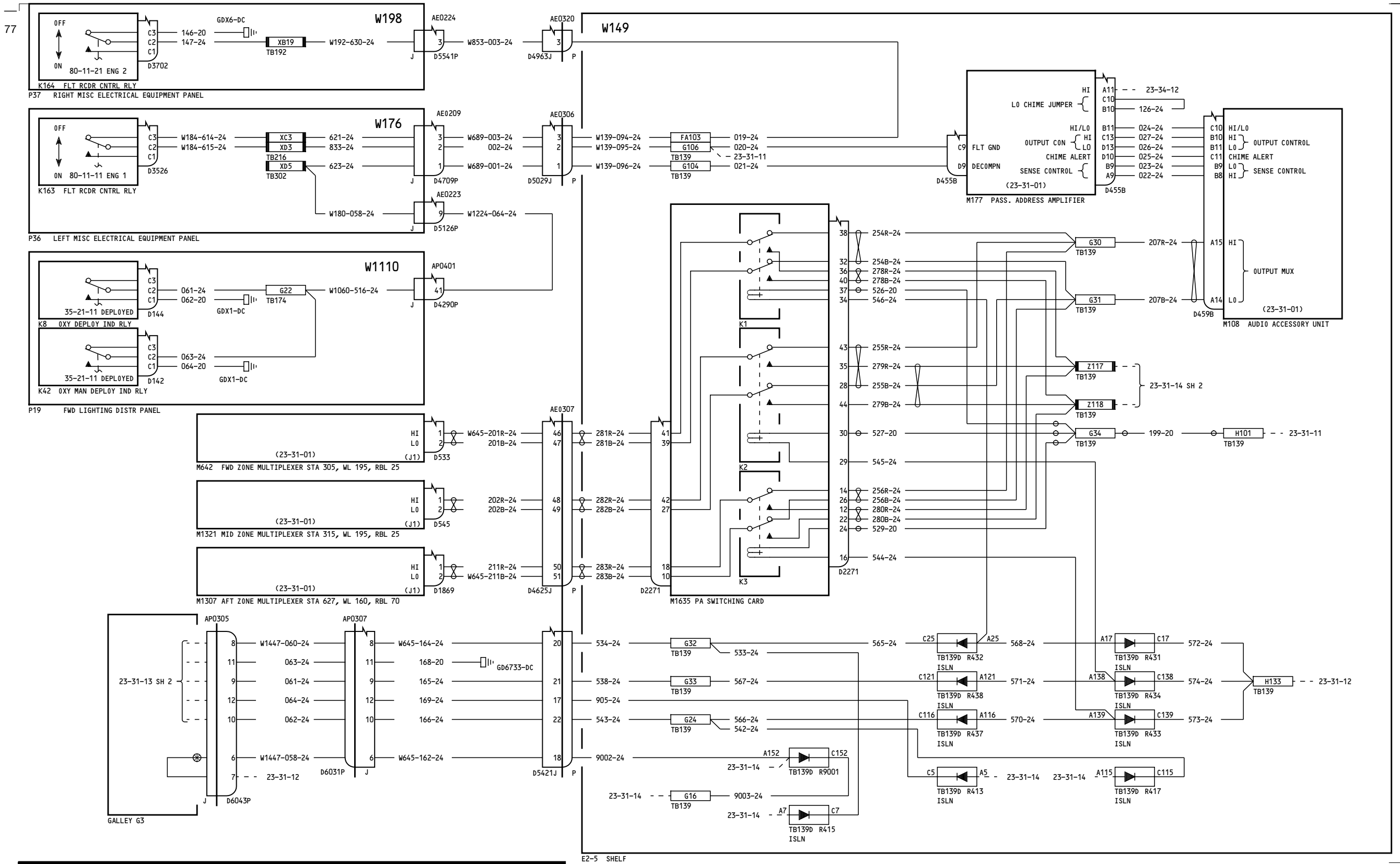

050

**PASSENGER ADDRESS-
OUTPUT CIRCUITRY &
CONTROLS**

D280T132

23-31-13

Page 1A
Sheet 1
Jan 21/2005

- Incorporates
- ▶ MTO 230452A
 - ▶ MTO 230485B
 - ▶ MTO 230540

23-31-13

Page 1A
Sheet 1
Jan 21/2005

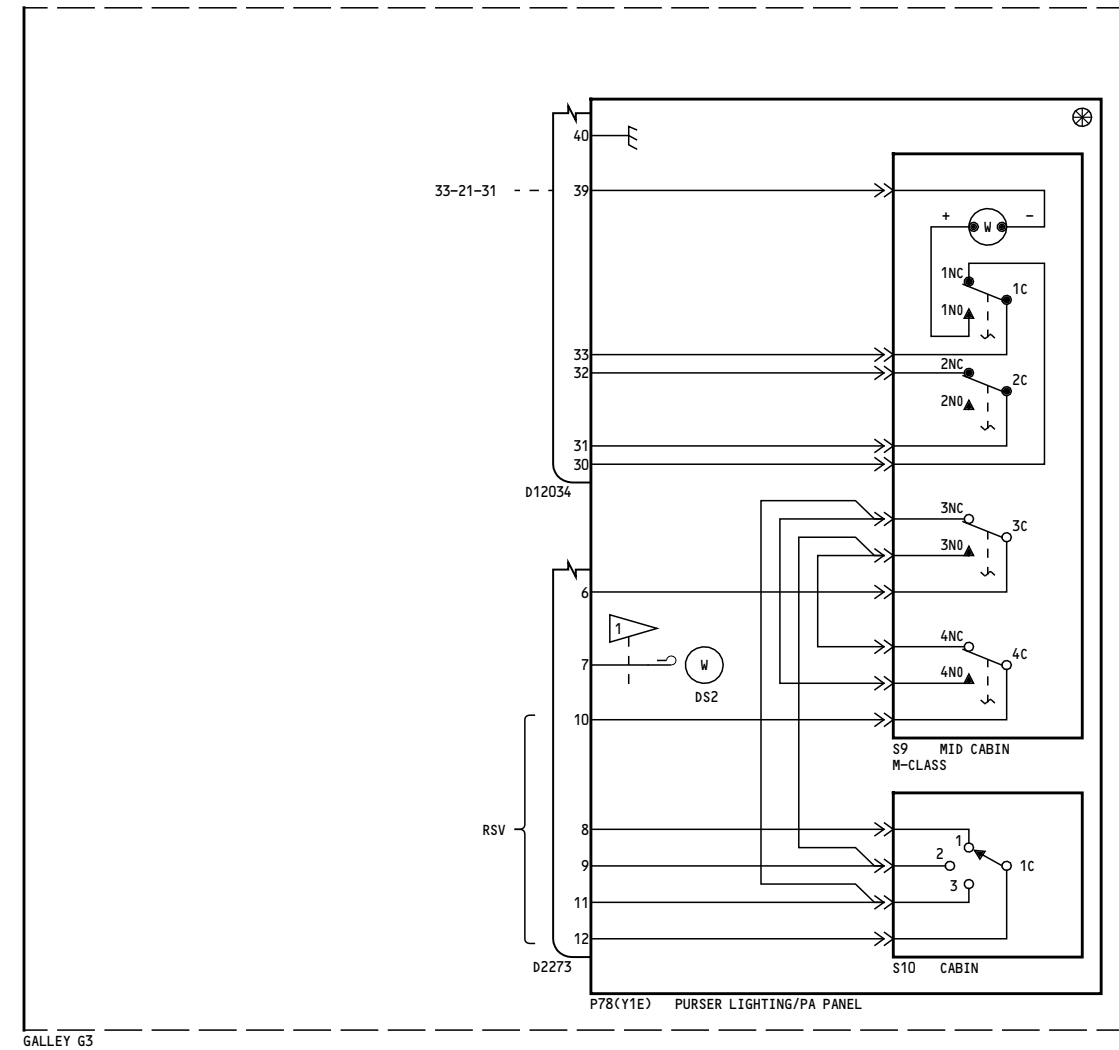

NOTES:
 1 CAP & STOW NEAR DS2

050

**PASSENGER ADDRESS-
 OUTPUT CIRCUITRY &
 CONTROLS**

D280T132

23-31-13

Page 1A
 Sheet 2
 Jan 21/2005

- Incorporates
- ▶ MTO 230452A
 - ▶ MTO 230485B
 - ▶ MTO 230540
 - ▶ MTO 330286 R01

23-31-13

Page 1A
 Sheet 2
 Jan 21/2005

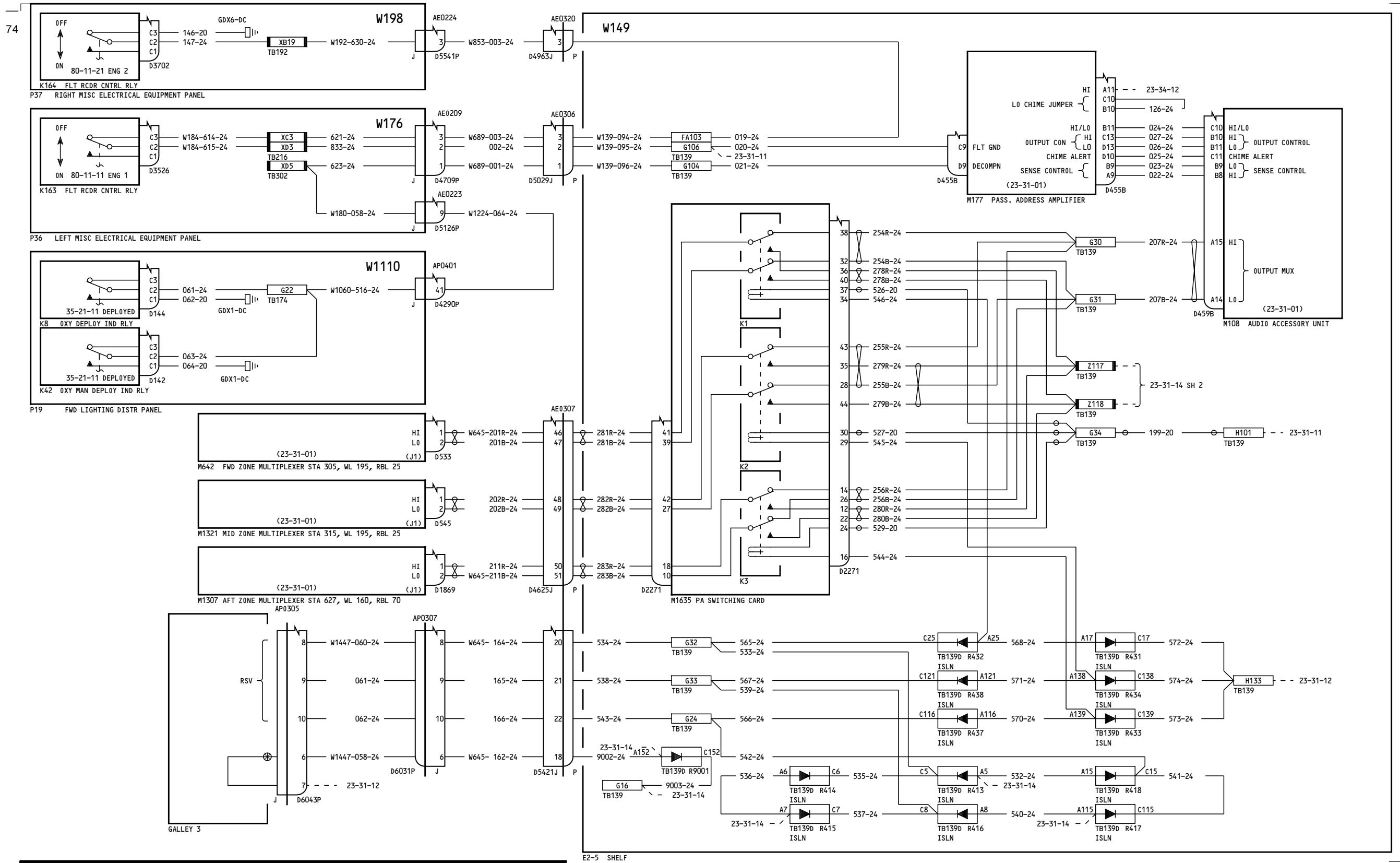

051

PASSENGER ADDRESS-
OUTPUT CIRCUITRY &
CONTROLS

D280T132

23-31-13

Page 2A

Jan 21/2005

Incorporates
▶ MTO 230452A
▶ MTO 230540

23-31-13

Page 2A

Jan 21/2005

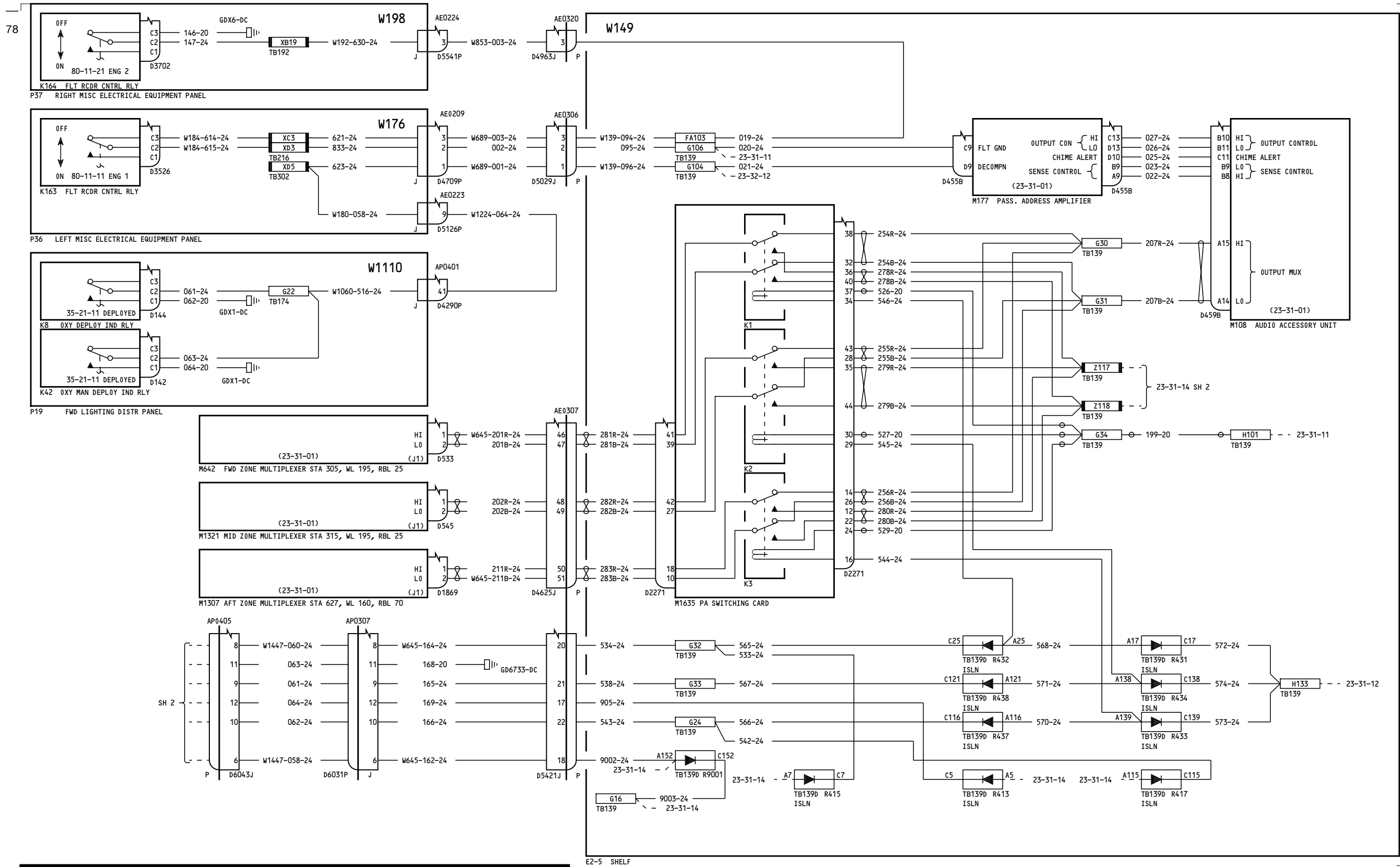

150, 154

PASSENGER ADDRESS-
OUTPUT CIRCUITRY &
CONTROLS

D280T132

23-31-13

Page 3A
Sheet 1
Jan 21/2005

Incorporates
▶ MTO 230452A
▶ MTO 230485B

23-31-13

Page 3A
Sheet 1
Jan 21/2005

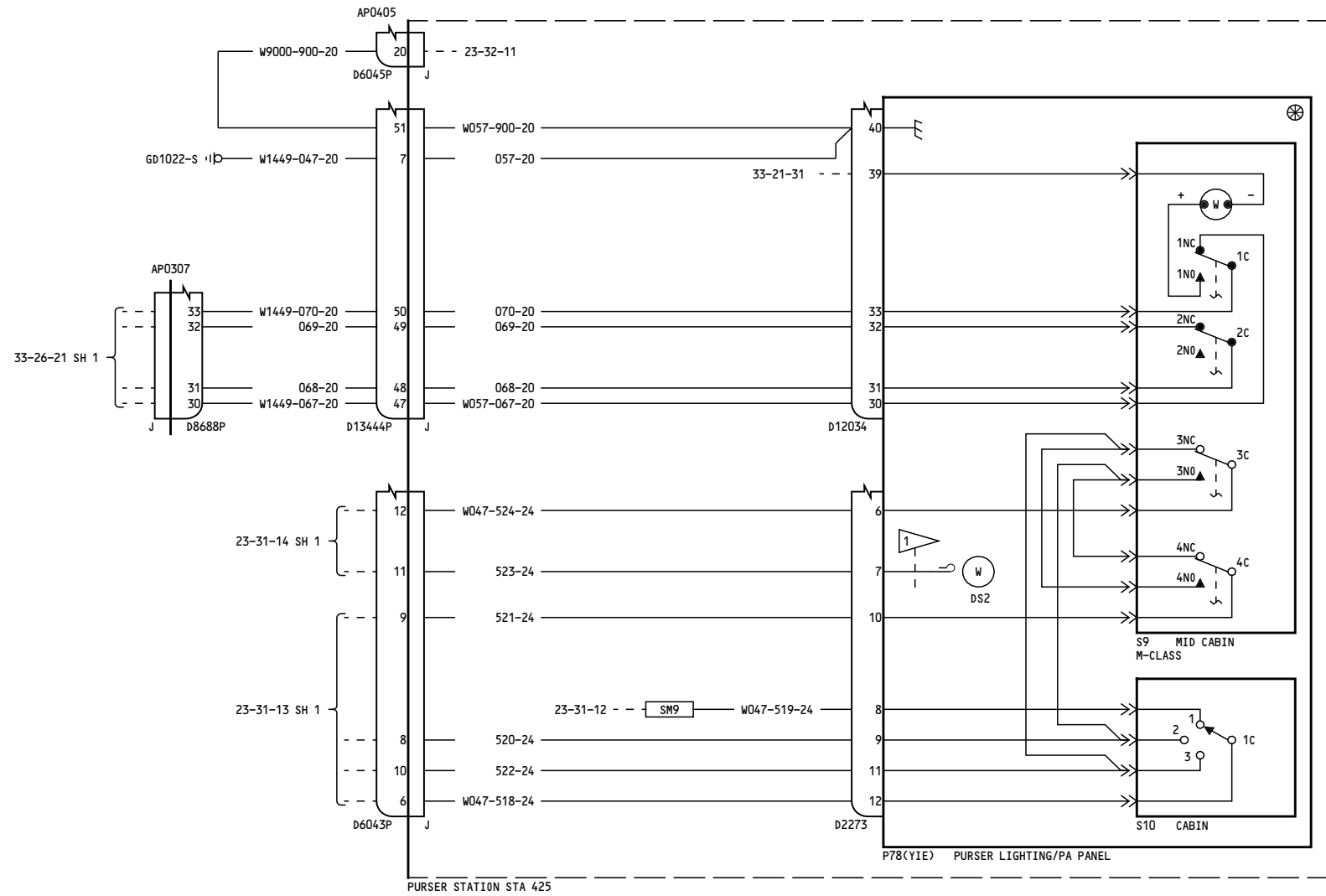

NOTES:
 1 CAP & STOW NEAR DS2

150, 154

**PASSENGER ADDRESS-
 OUTPUT CIRCUITRY &
 CONTROLS**

D280T132

23-31-13

Page 3A
 Sheet 2
 Jan 21/2005

- Incorporates
- ▶ MTO 230452A
 - ▶ MTO 230485B
 - ▶ MTO 330286

23-31-13

Page 3A
 Sheet 2
 Jan 21/2005

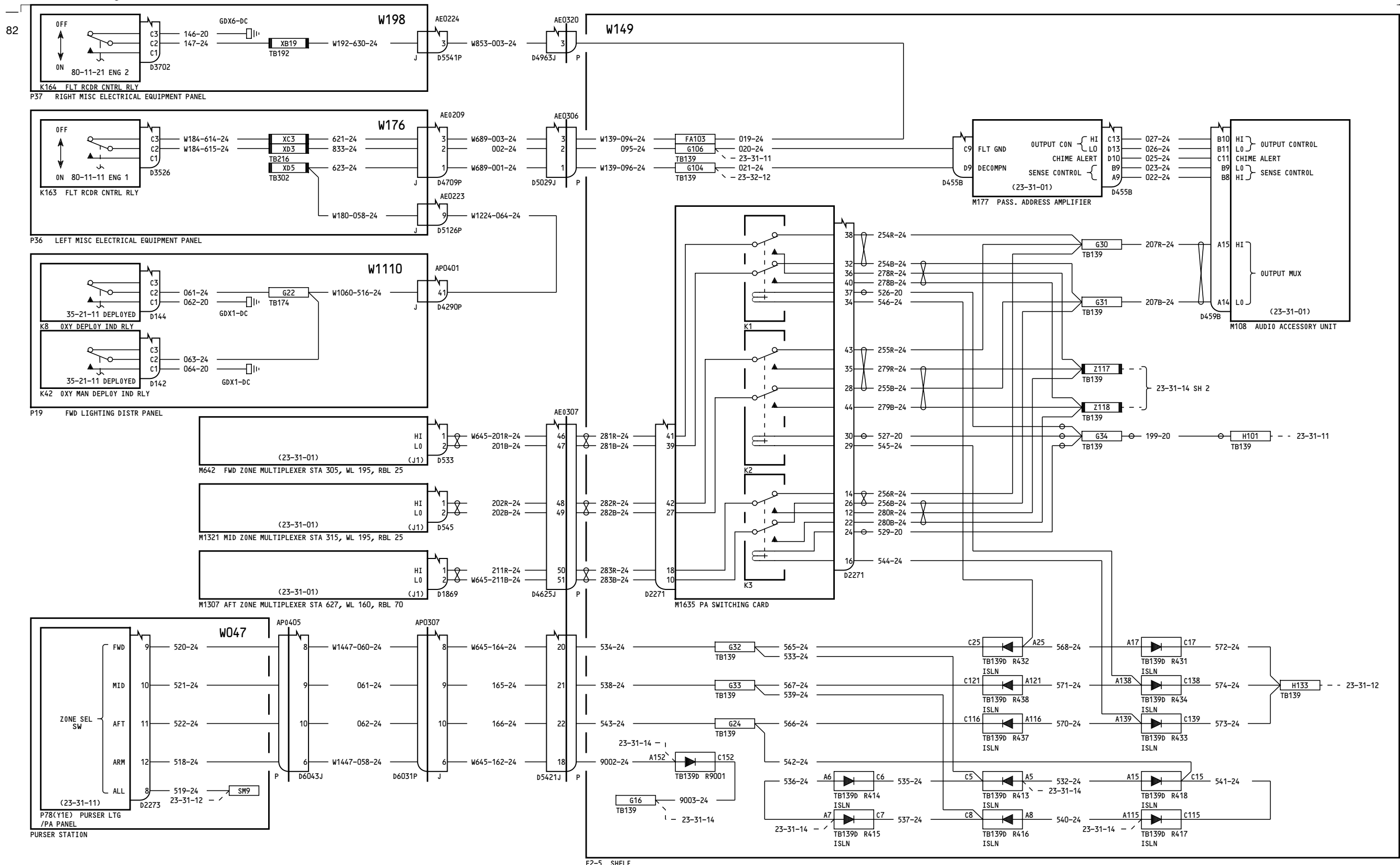

151-153

**PASSENGER ADDRESS-
OUTPUT CIRCUITRY &
CONTROLS**

23-31-13

Page 4A

Jan 21/2005

D280T132

Incorporates
MTO 230452A

23-31-13

Page 4A

Jan 21/2005

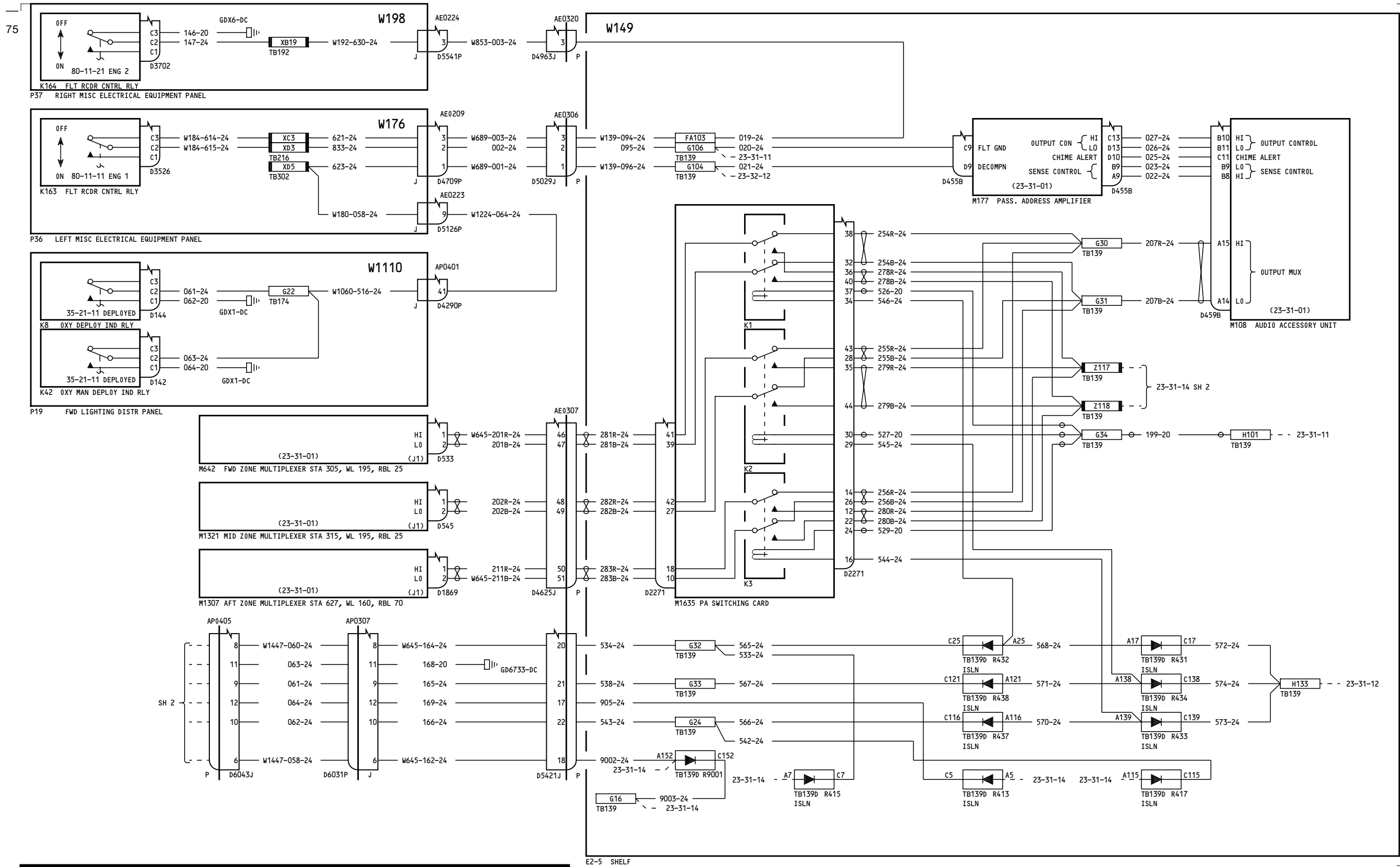

155

**PASSENGER ADDRESS-
OUTPUT CIRCUITRY &
CONTROLS**

D280T132

23-31-13

Page 5A
Sheet 1
Jan 21/2005

Incorporates
▶ MTO 230452A
▶ MTO 230485B

23-31-13

Page 5A
Sheet 1
Jan 21/2005

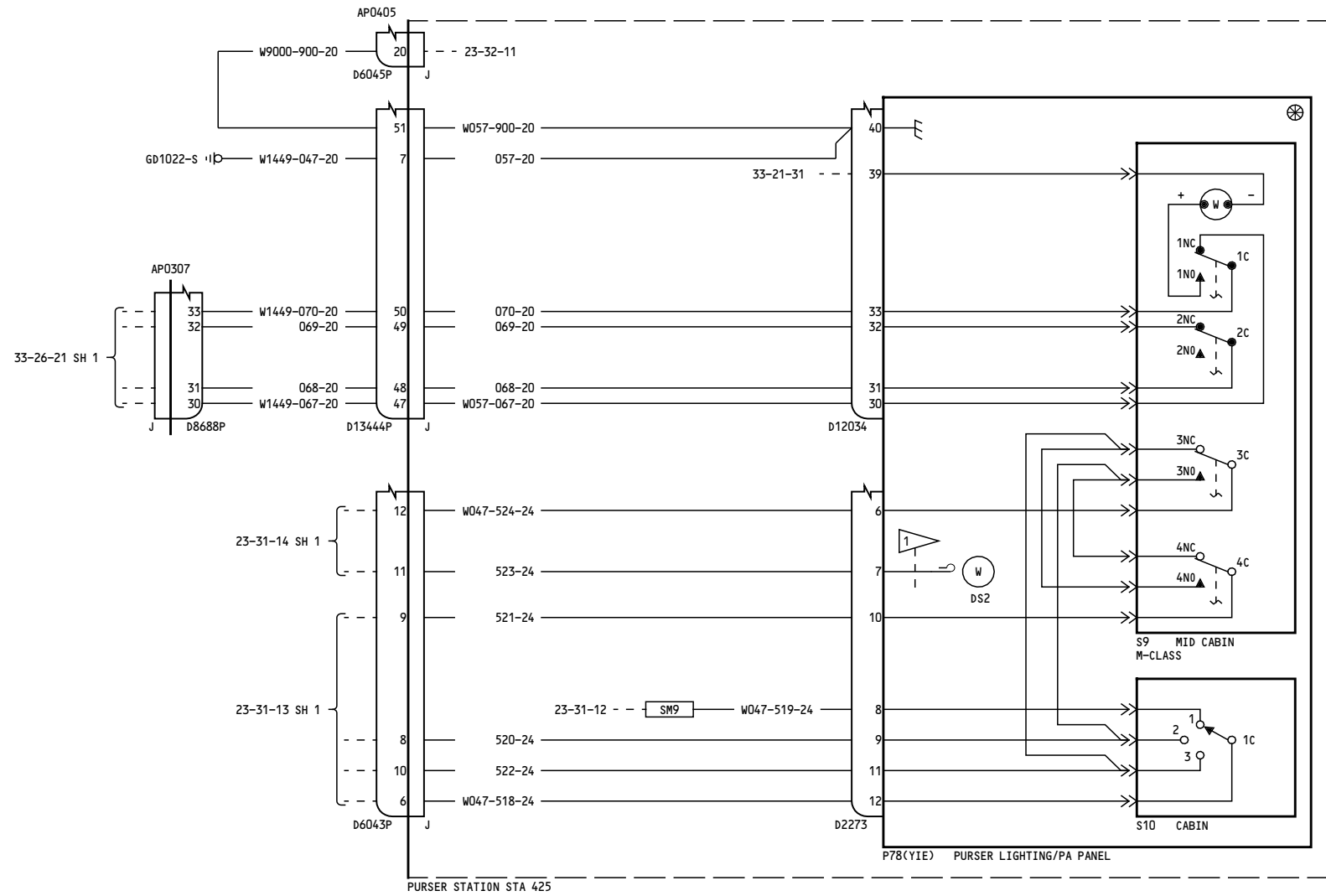

NOTES:
 1 CAP & STOW NEAR DS2

155

**PASSENGER ADDRESS-
 OUTPUT CIRCUITRY &
 CONTROLS**

D280T132

23-31-13

Page 5A
 Sheet 2
 Jan 21/2005

- Incorporates
- ▶ MTO 230452A
 - ▶ MTO 230485B
 - ▶ MTO 330286 R01

23-31-13

Page 5A
 Sheet 2
 Jan 21/2005

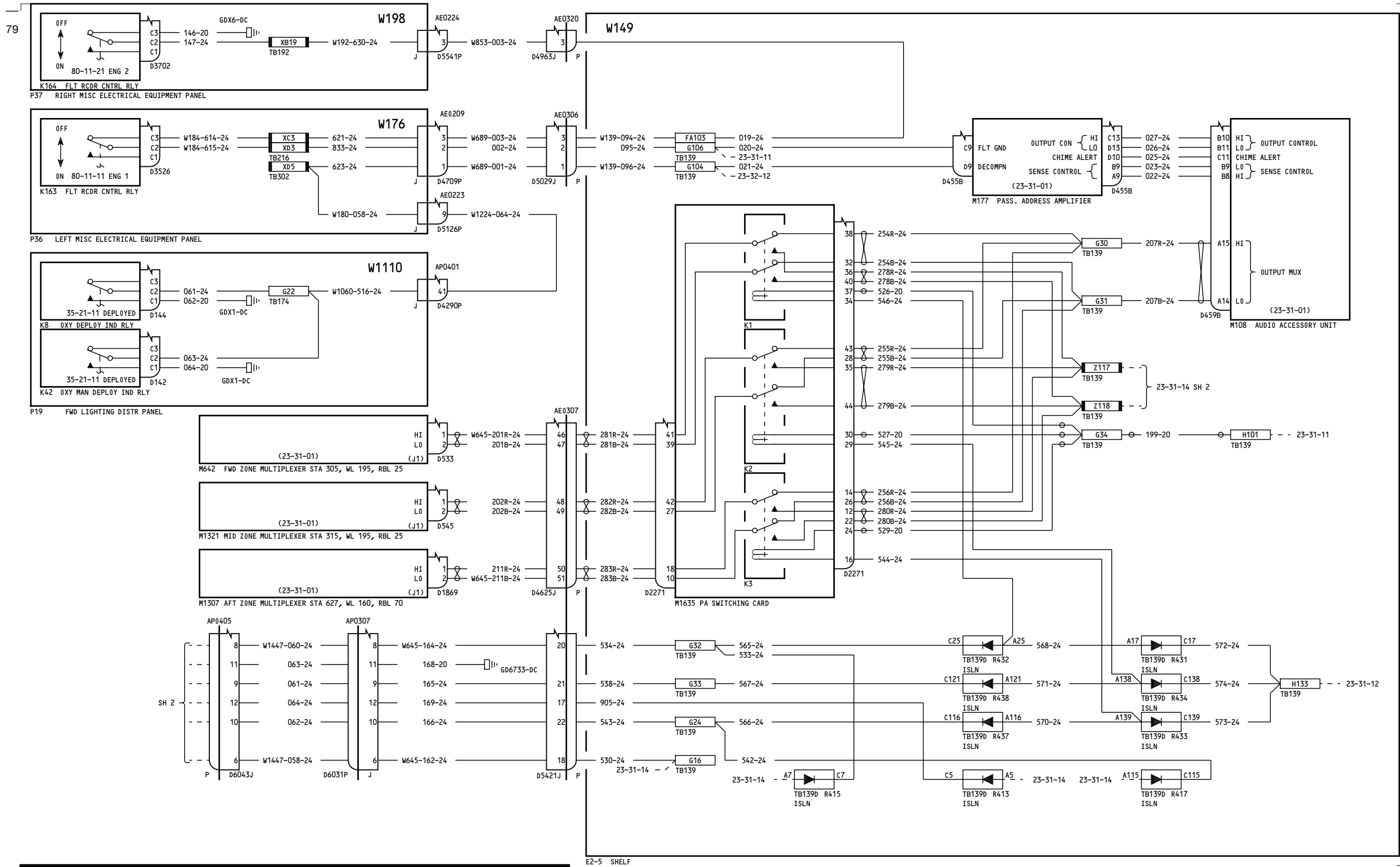

156-157, 167

PASSENGER ADDRESS-OUTPUT CIRCUITRY & CONTROLS

D280T132

23-31-13

Page 6A
Sheet 1
Jan 21/2005

Incorporates
MTO 230452A
MTO 230485B

23-31-13

Page 6A
Sheet 1
Jan 21/2005

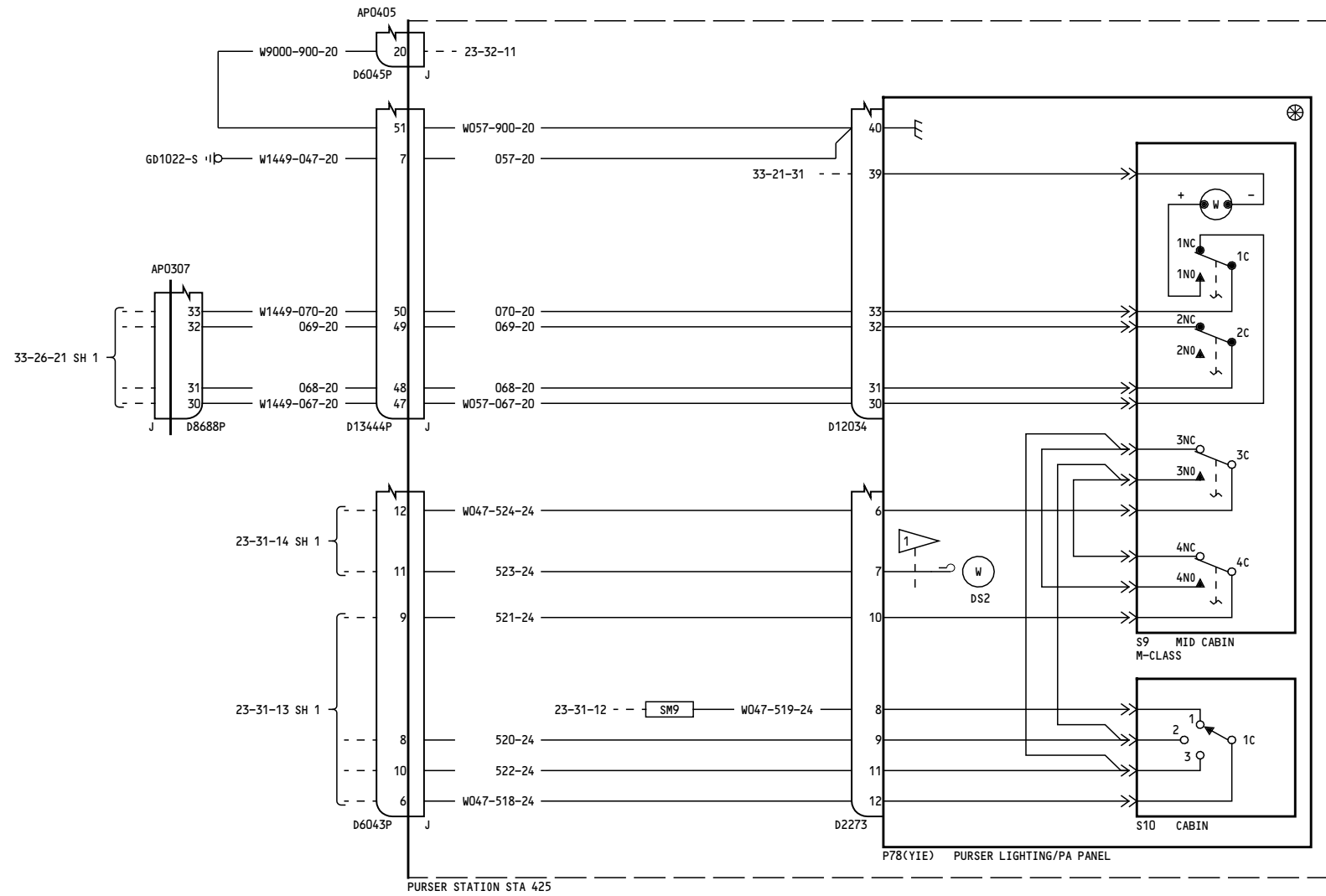

NOTES:
 1 CAP & STOW NEAR DS2

156-157, 167

**PASSENGER ADDRESS-
 OUTPUT CIRCUITRY &
 CONTROLS**

D280T132

23-31-13

Page 6A
 Sheet 2
 Jan 21/2005

Incorporates
 MTO 230452A
 MTO 230485B

23-31-13

Page 6A
 Sheet 2
 Jan 21/2005

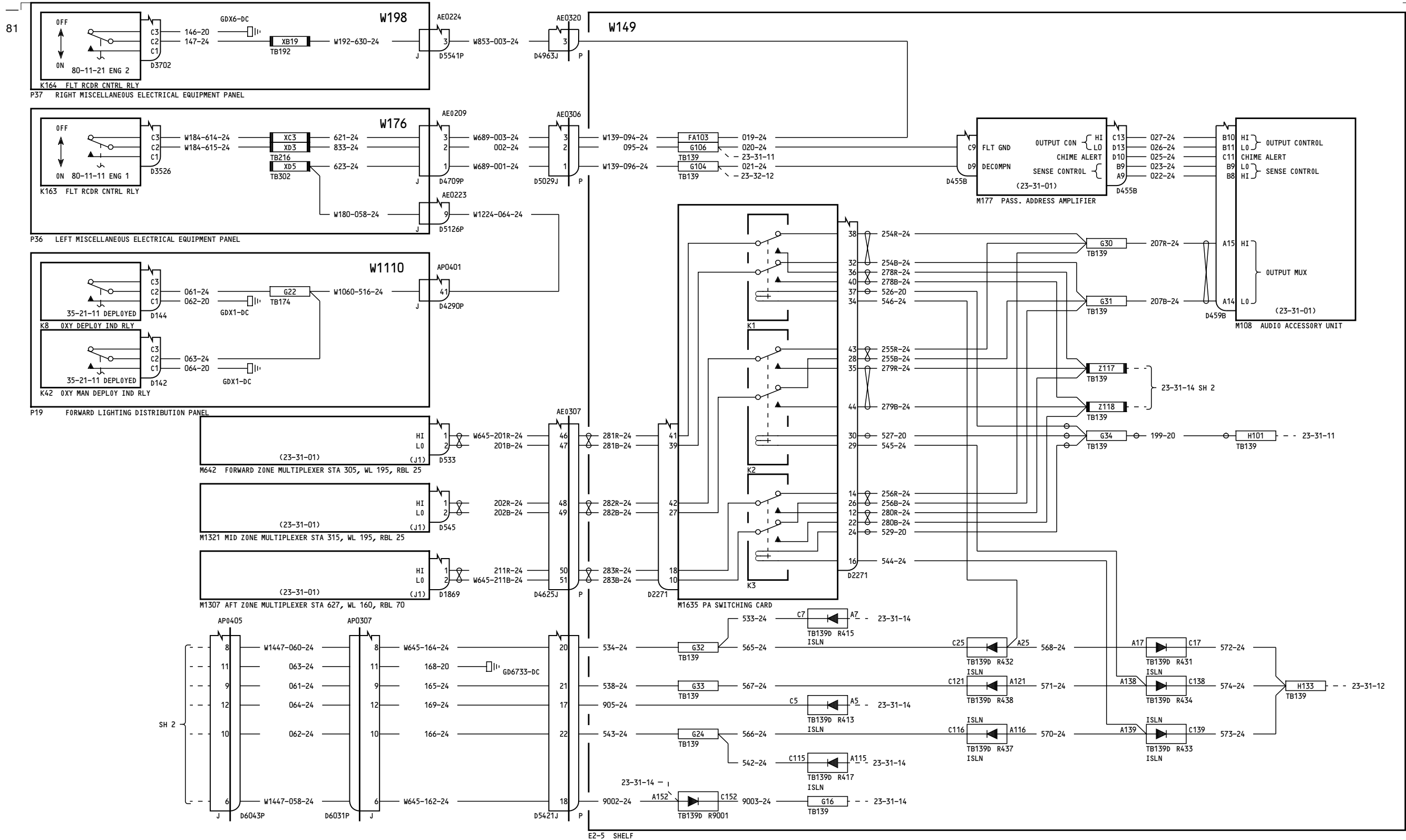

162-165

PASSENGER ADDRESS-
OUTPUT CIRCUITRY &
CONTROLS

D280T132

23-31-13

Page 7A
Sheet 1
Jan 21/2005

Incorporates
▶ MTO 230452A
▶ MTO 230485B

23-31-13

Page 7A
Sheet 1
Jan 21/2005

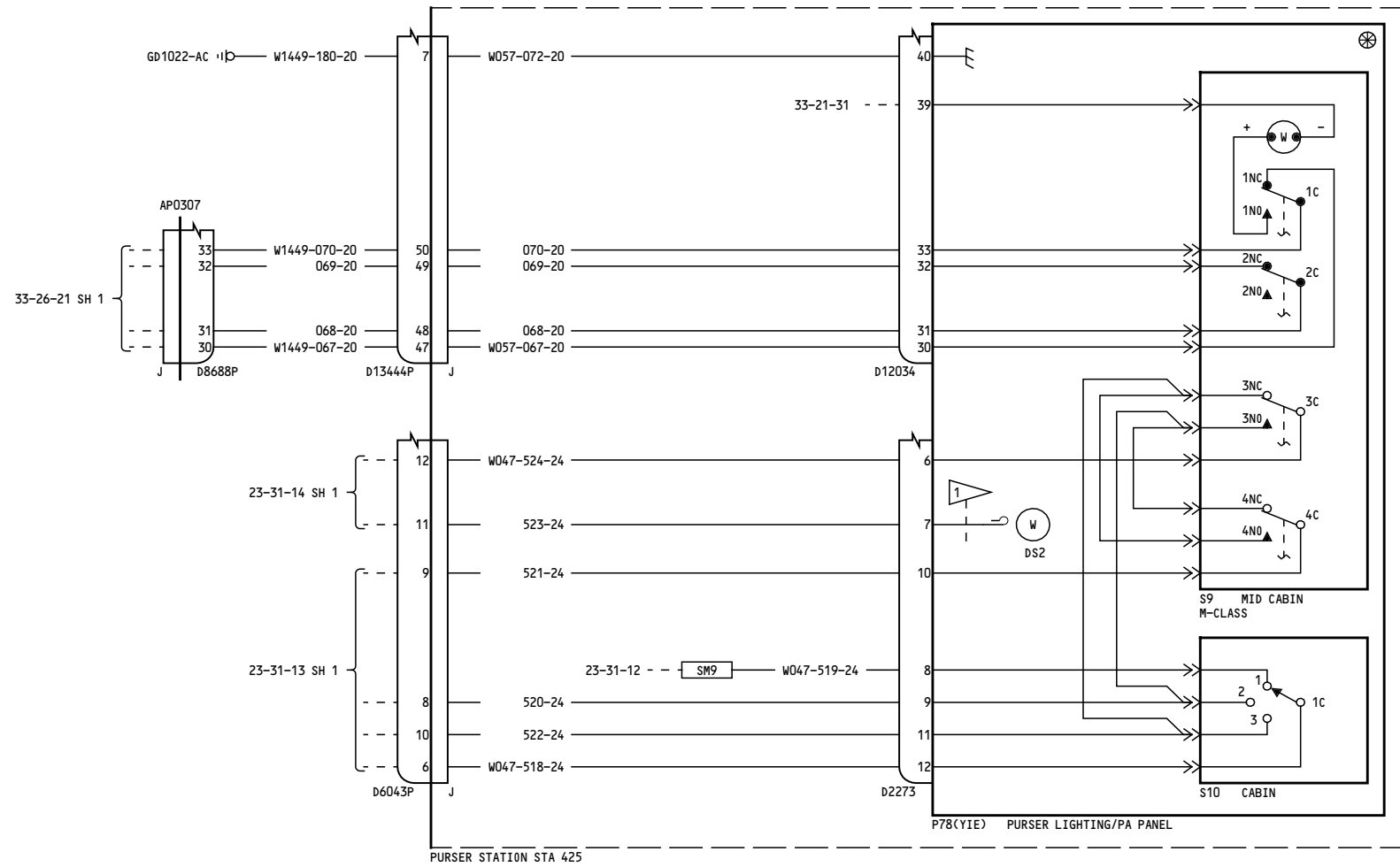

NOTES:
 1 CAP & STOW NEAR DS2

162-165

**PASSENGER ADDRESS-
 OUTPUT CIRCUITRY &
 CONTROLS**

D280T132

23-31-13

Page 7A
 Sheet 2
 Jan 21/2005

- Incorporates
- ▶ MTO 230452A
 - ▶ MTO 230485B
 - ▶ MTO 330286
 - ▶ MTO 330348

23-31-13

Page 7A
 Sheet 2
 Jan 21/2005

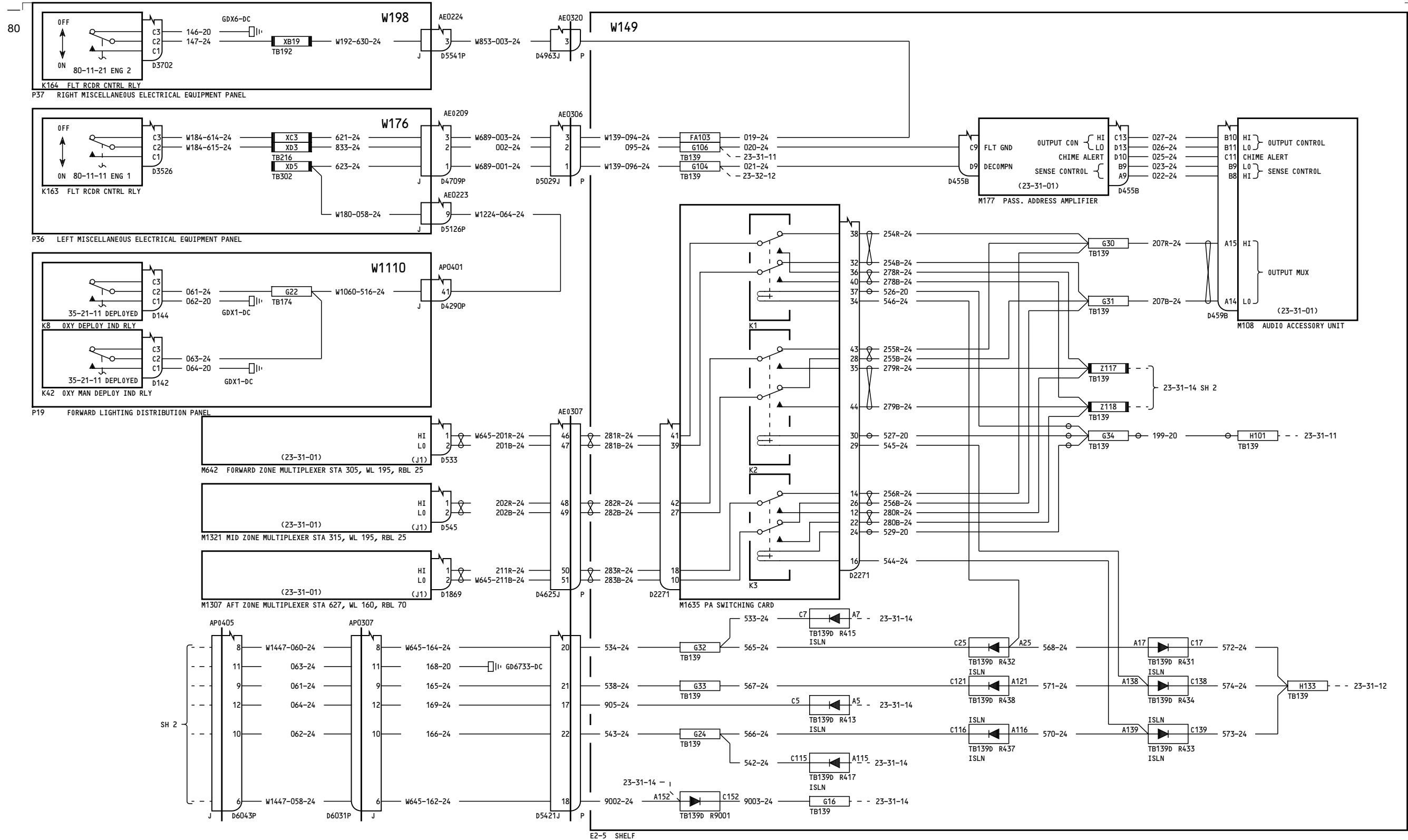

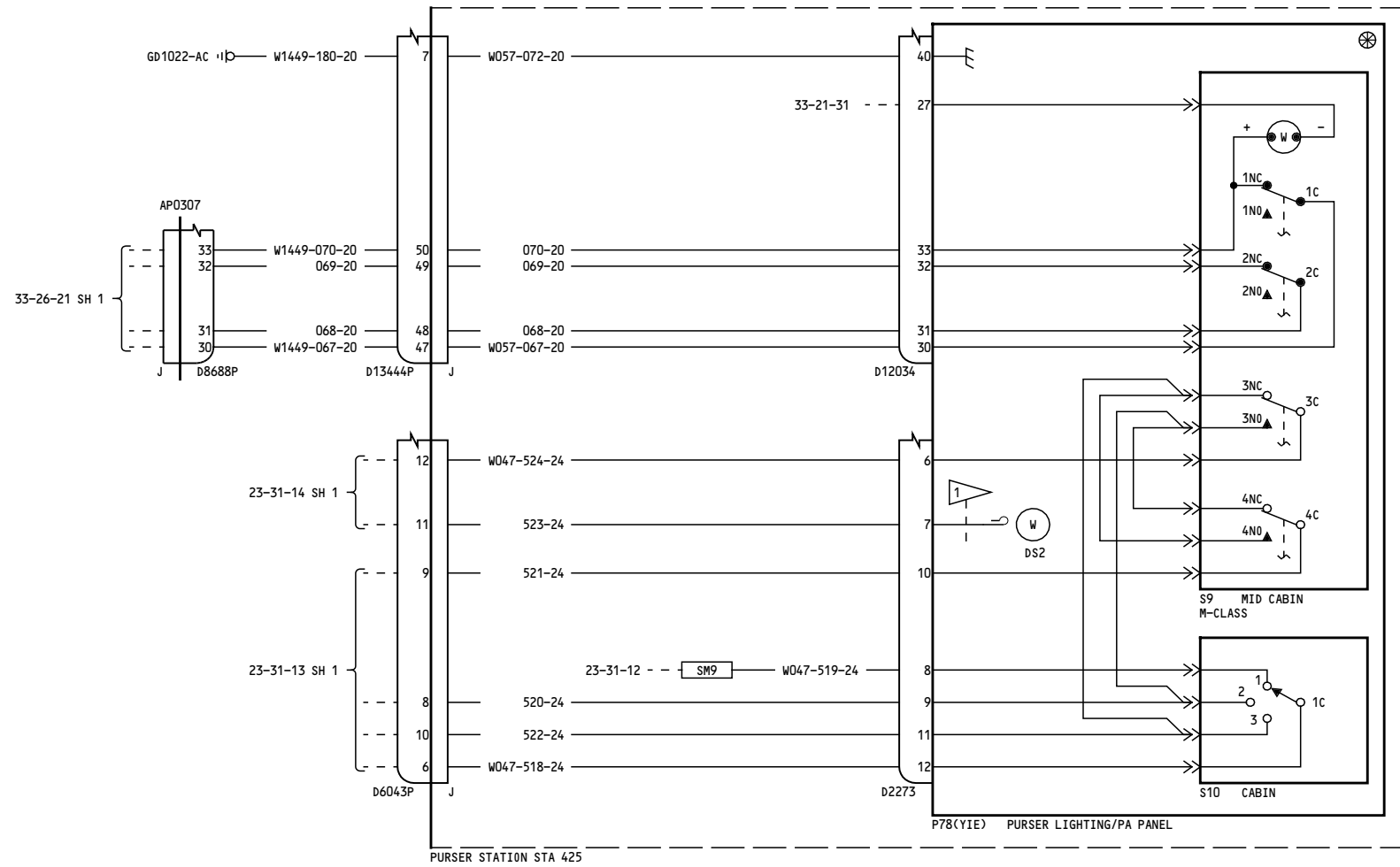

NOTES:
 1 CAP & STOW NEAR DS2

166

**PASSENGER ADDRESS-
 OUTPUT CIRCUITRY &
 CONTROLS**

D280T132

23-31-13

Page 8A
 Sheet 2
 Jan 21/2005

Incorporates
 MTO 230452A
 MTO 230485B

23-31-13

Page 8A
 Sheet 2
 Jan 21/2005

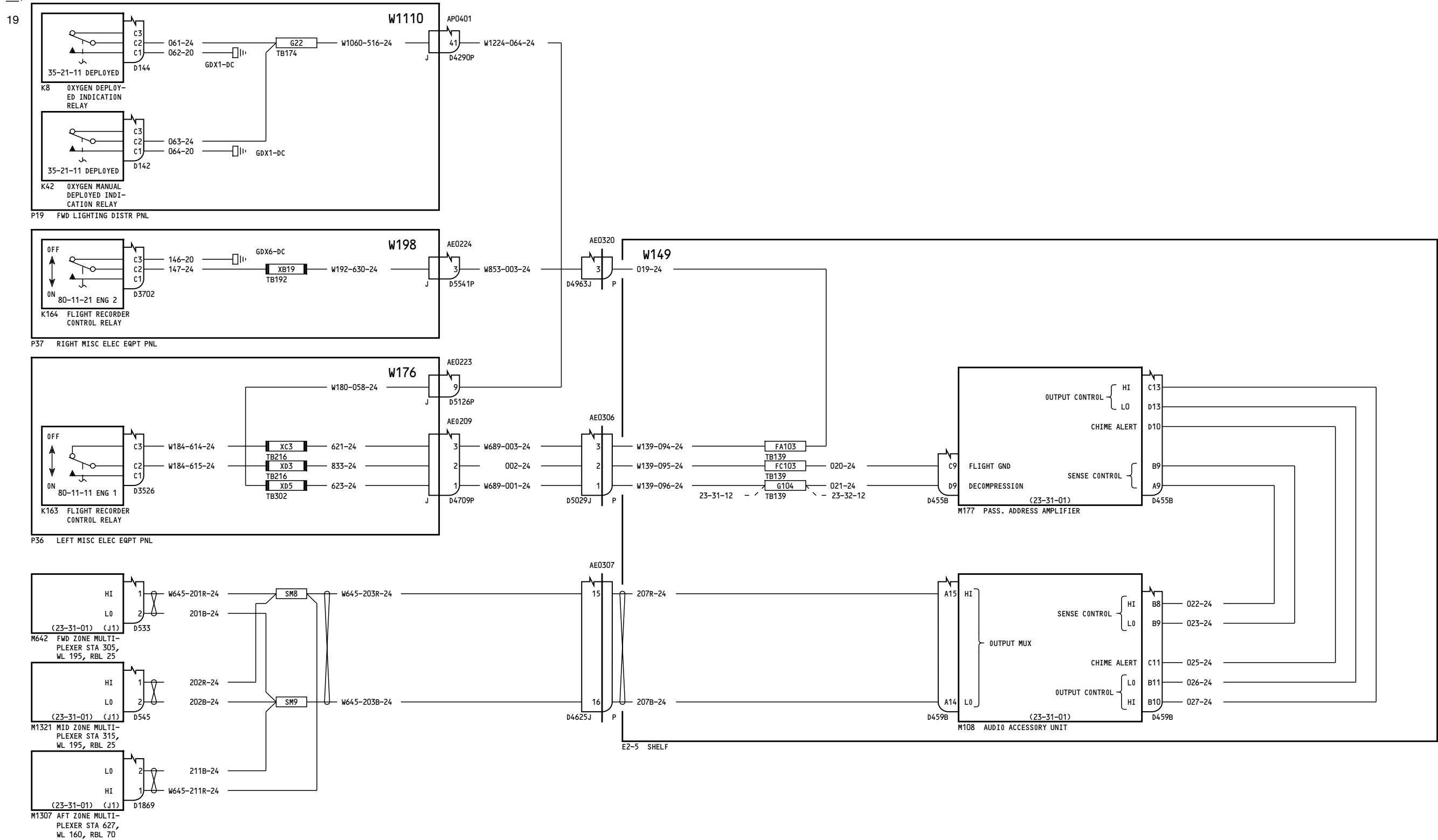

275-299

**PASSENGER ADDRESS-
OUTPUT CIRCUITRY &
CONTROLS**

23-31-13

Page 9

Jan 21/2005

D280T132

23-31-13

Page 9

Jan 21/2005

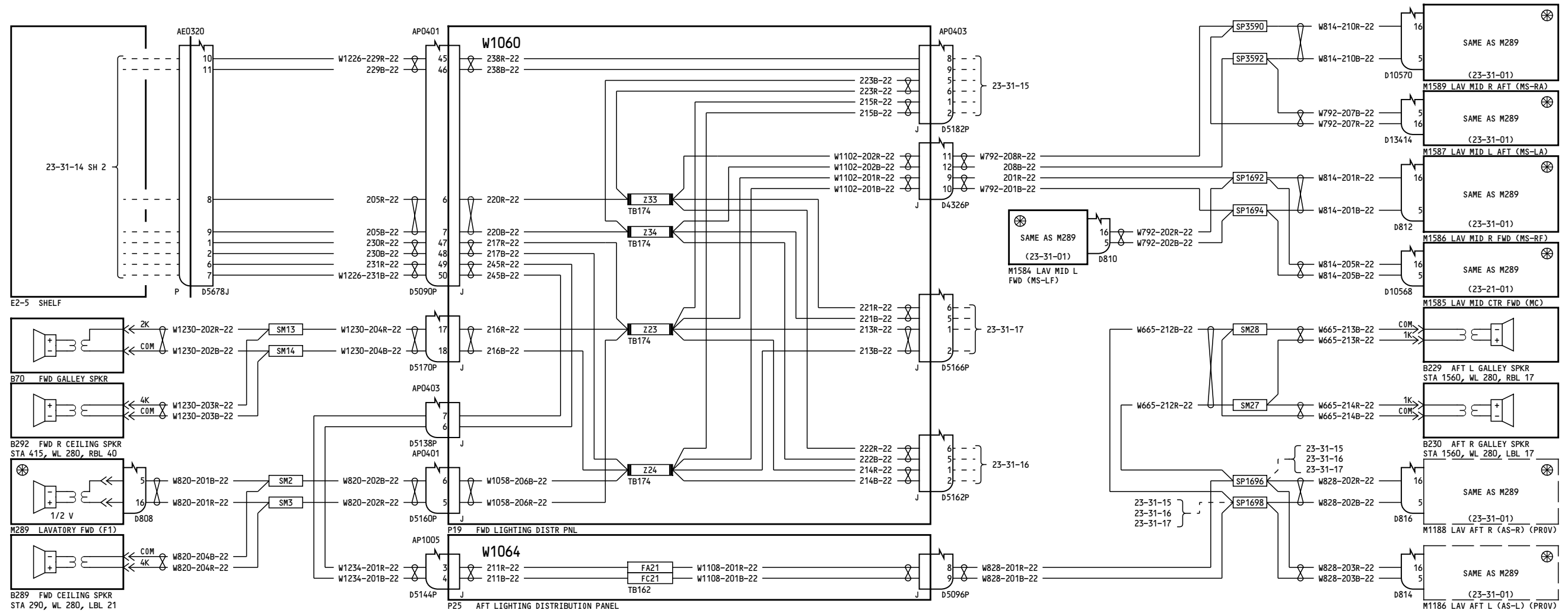
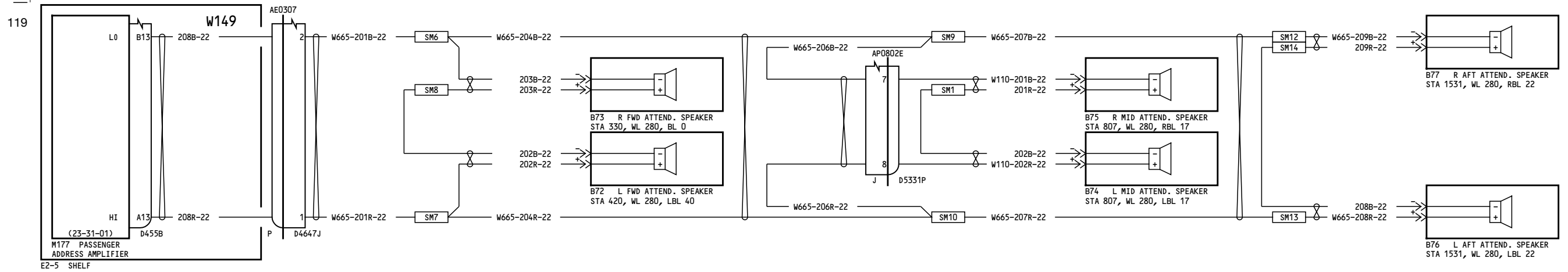

050

PASSENGER ADDRESS-SPEAKERS-ATTENDANT, GALLEY & LAVATORY

23-31-14

Incorporates
 MTO 230485B
 MTO 230540

23-31-14

D280T132

Page 1A
 Sheet 1
 Jan 21/2005

Page 1A
 Sheet 1
 Jan 21/2005

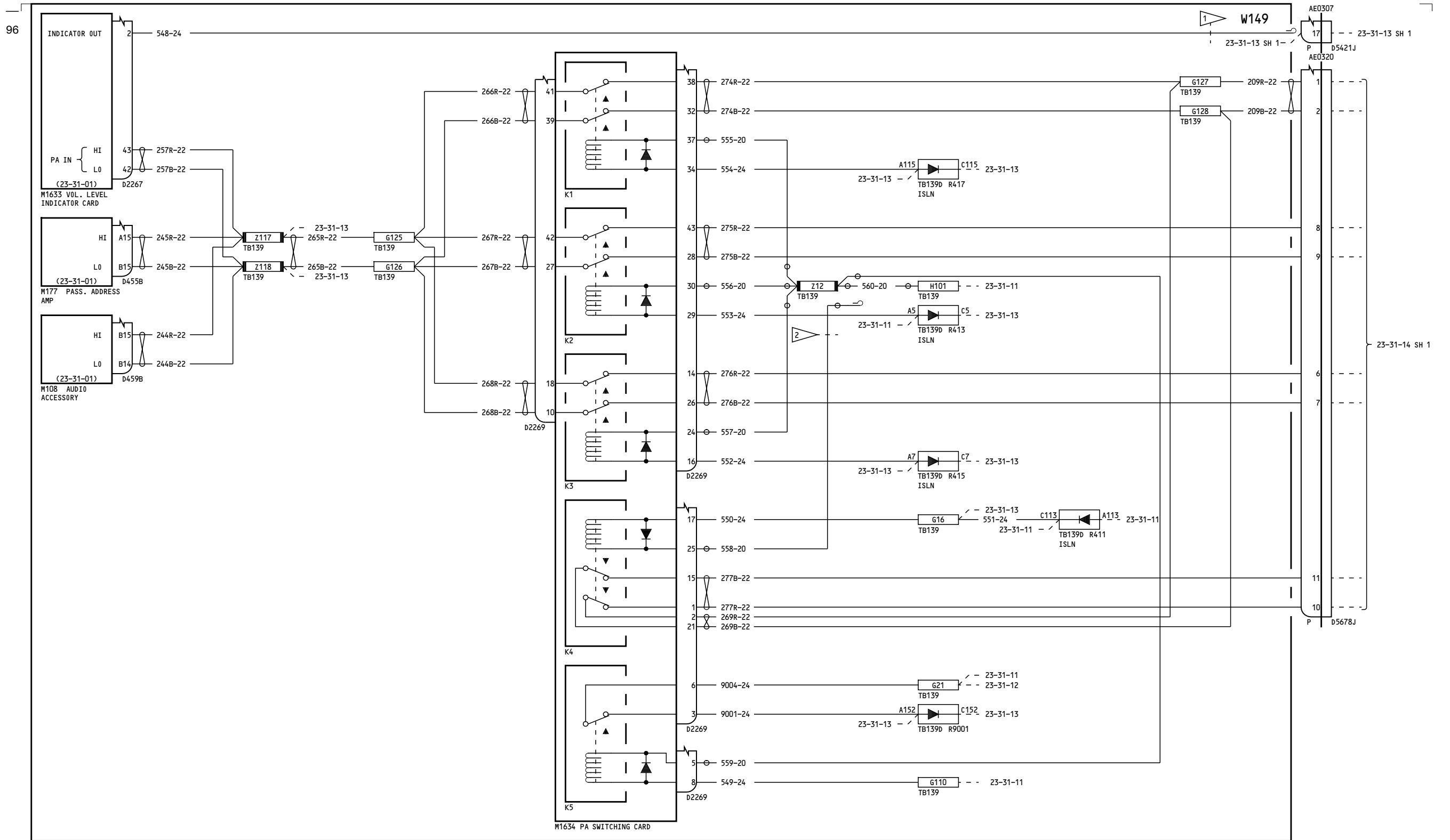

E2-5 SHELF NOTES:
 1 CAP & STOW NEAR D5421P 2 CAP & STOW NEAR TB139Z

050

PASSENGER ADDRESS-SPEAKERS-ATTENDANT, GALLEY & LAVATORY

D280T132

23-31-14

Page 1A
 Sheet 2
 Jan 21/2005

- Incorporates
- ▶ MTO 230452A
 - ▶ MTO 230485B
 - ▶ MTO 230540

23-31-14

Page 1A
 Sheet 2
 Jan 21/2005

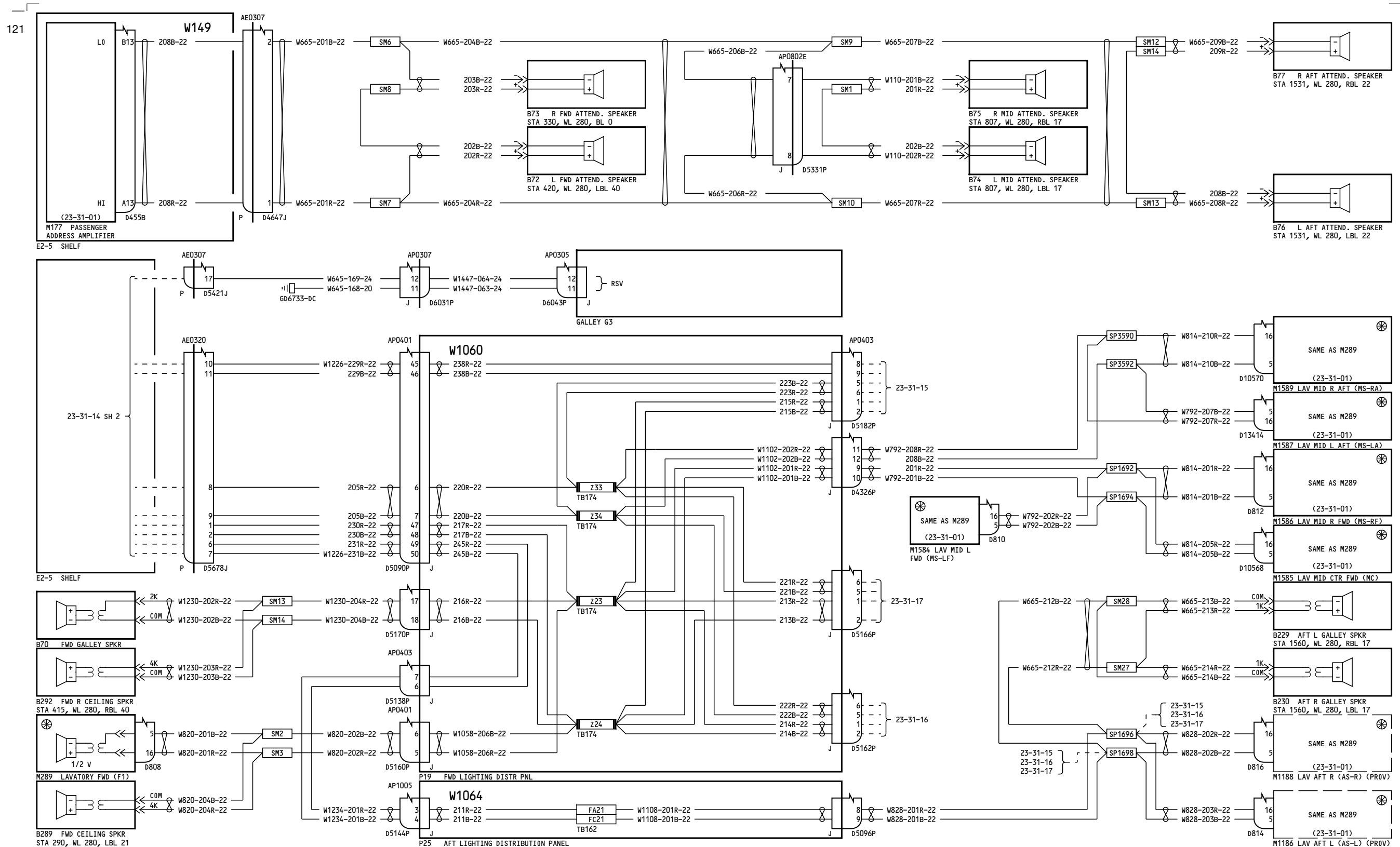

051

PASSENGER ADDRESS-SPEAKERS-ATTENDANT, GALLEY & LAVATORY

D280T132

23-31-14

Page 2A
Sheet 1
Jan 21/2005

Incorporates
MTO 230540

23-31-14

Page 2A
Sheet 1
Jan 21/2005

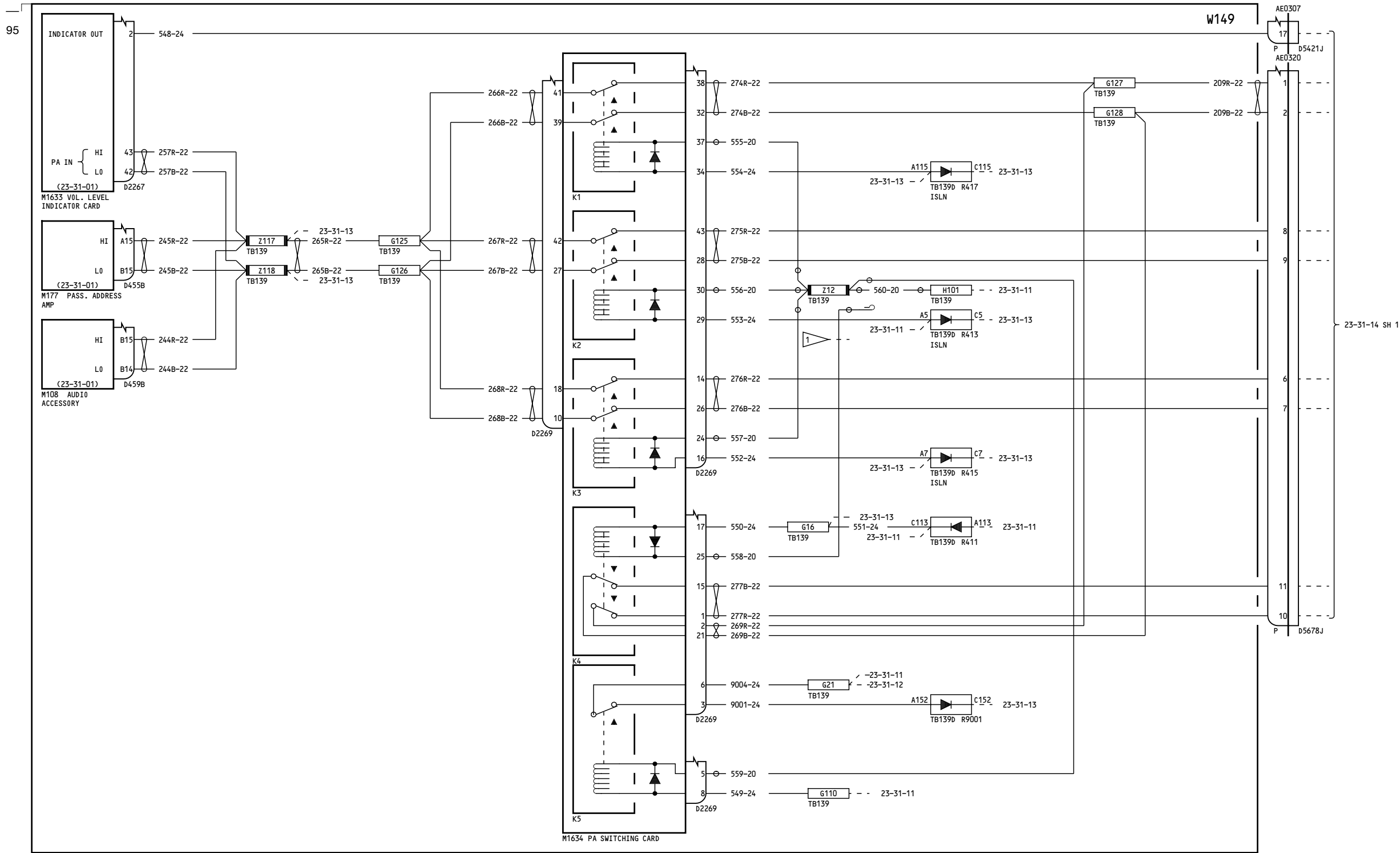

1 CAP & STOW NEAR TB139Z

051

PASSENGER ADDRESS-SPEAKERS-ATTENDANT, GALLEY & LAVATORY

D280T132

23-31-14

Page 2A
Sheet 2
Jan 21/2005

Incorporates
 MTO 230452A
 MTO 230540

23-31-14

Page 2A
Sheet 2
Jan 21/2005

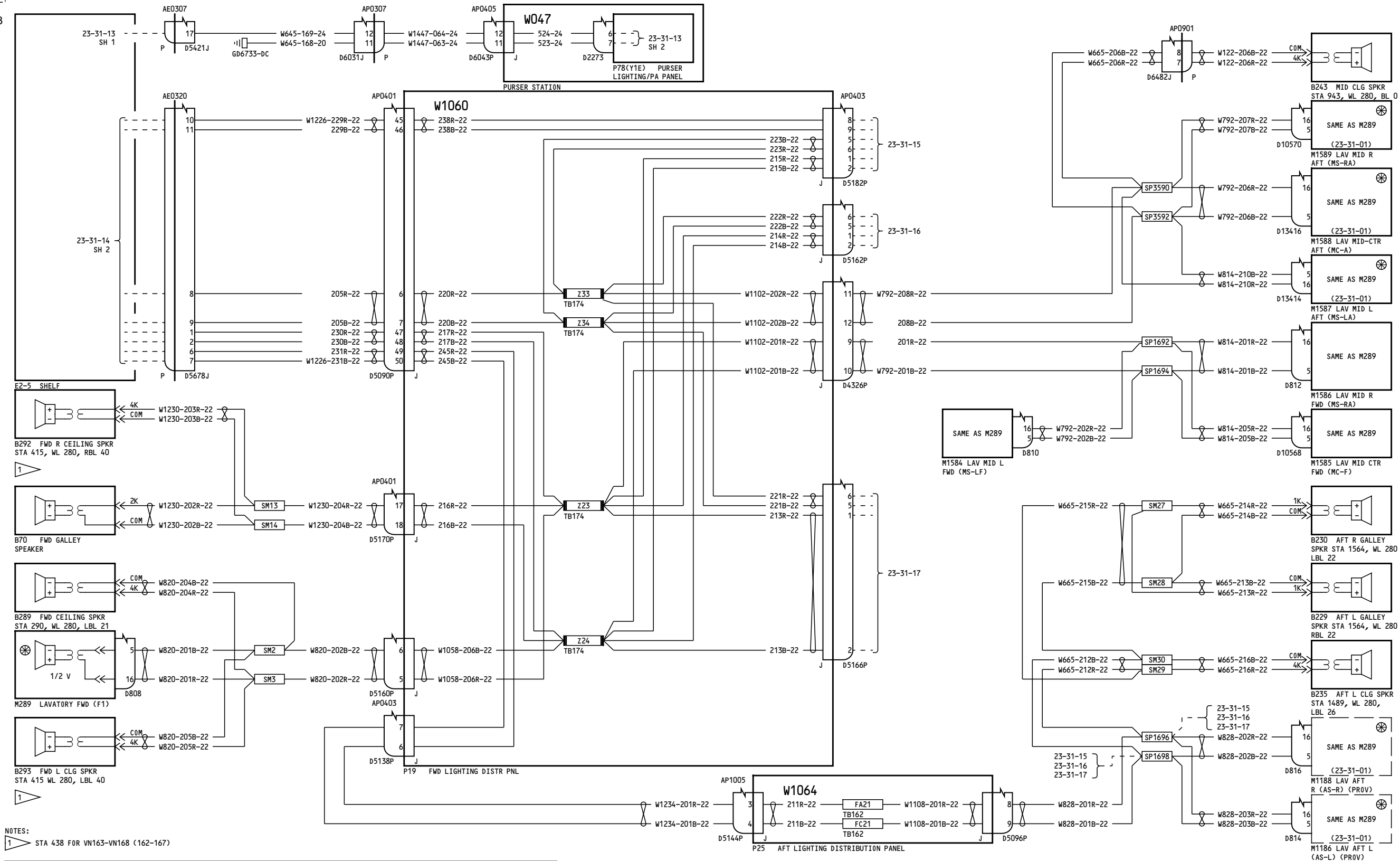

NOTES:
 1 STA 438 FOR VN163-VN168 (162-167)

150, 154-167

PASSENGER ADDRESS-SPEAKERS-ATTENDANT, GALLEY & LAVATORY

D280T132

23-31-14

Page 3A
 Sheet 1
 Jan 21/2005

Incorporates
 MTO 230485B

23-31-14

Page 3A
 Sheet 1
 Jan 21/2005

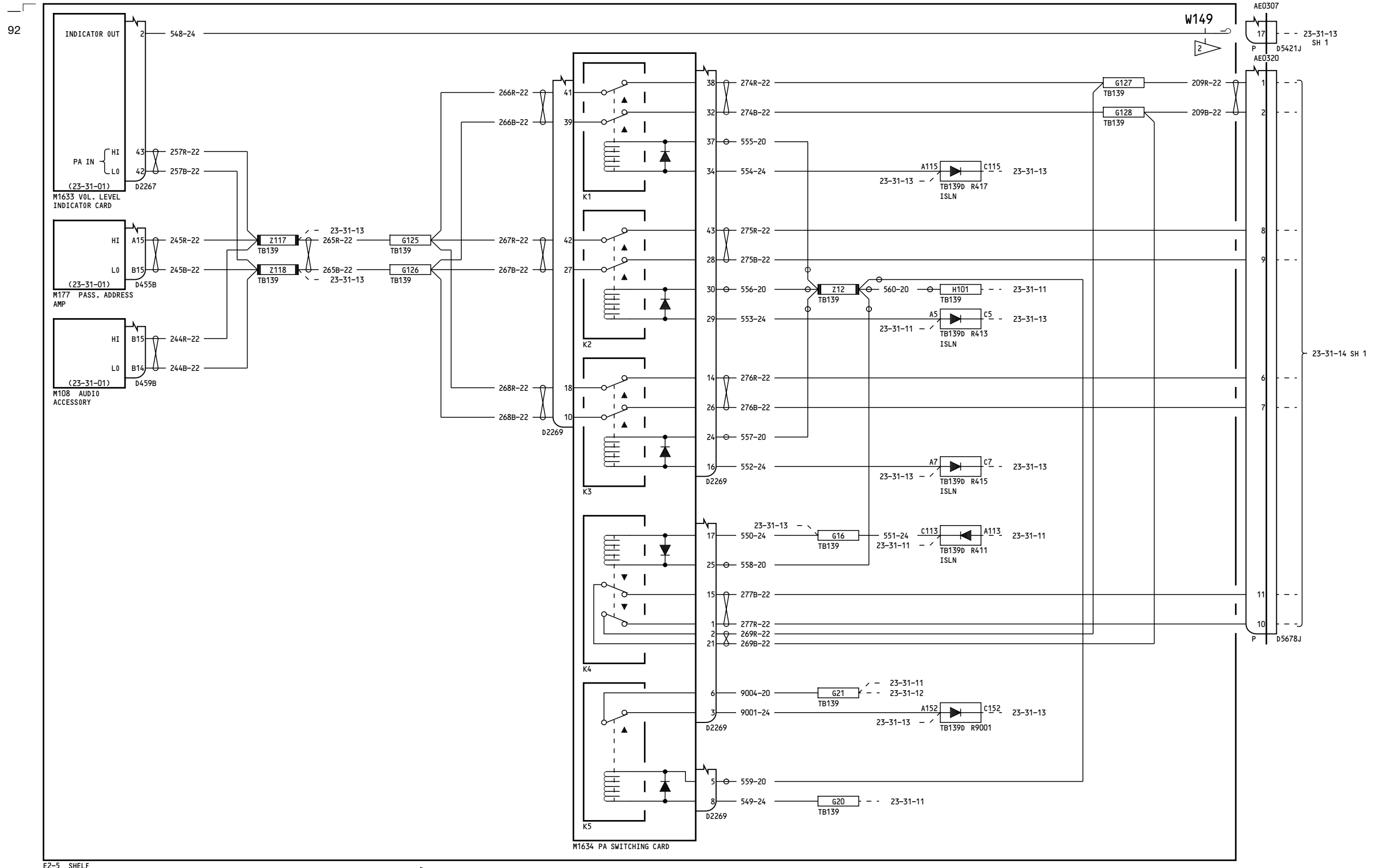

92

E2-5 SHELF

2 CAP & STOW NEAR D5421

150, 154-167

PASSENGER ADDRESS-SPEAKERS-ATTENDANT, GALLEY & LAVATORY

D280T132

23-31-14

Page 3A
Sheet 2
Jan 21/2005

Incorporates
MTO 230452A
MTO 230485B

23-31-14

Page 3A
Sheet 2
Jan 21/2005

122

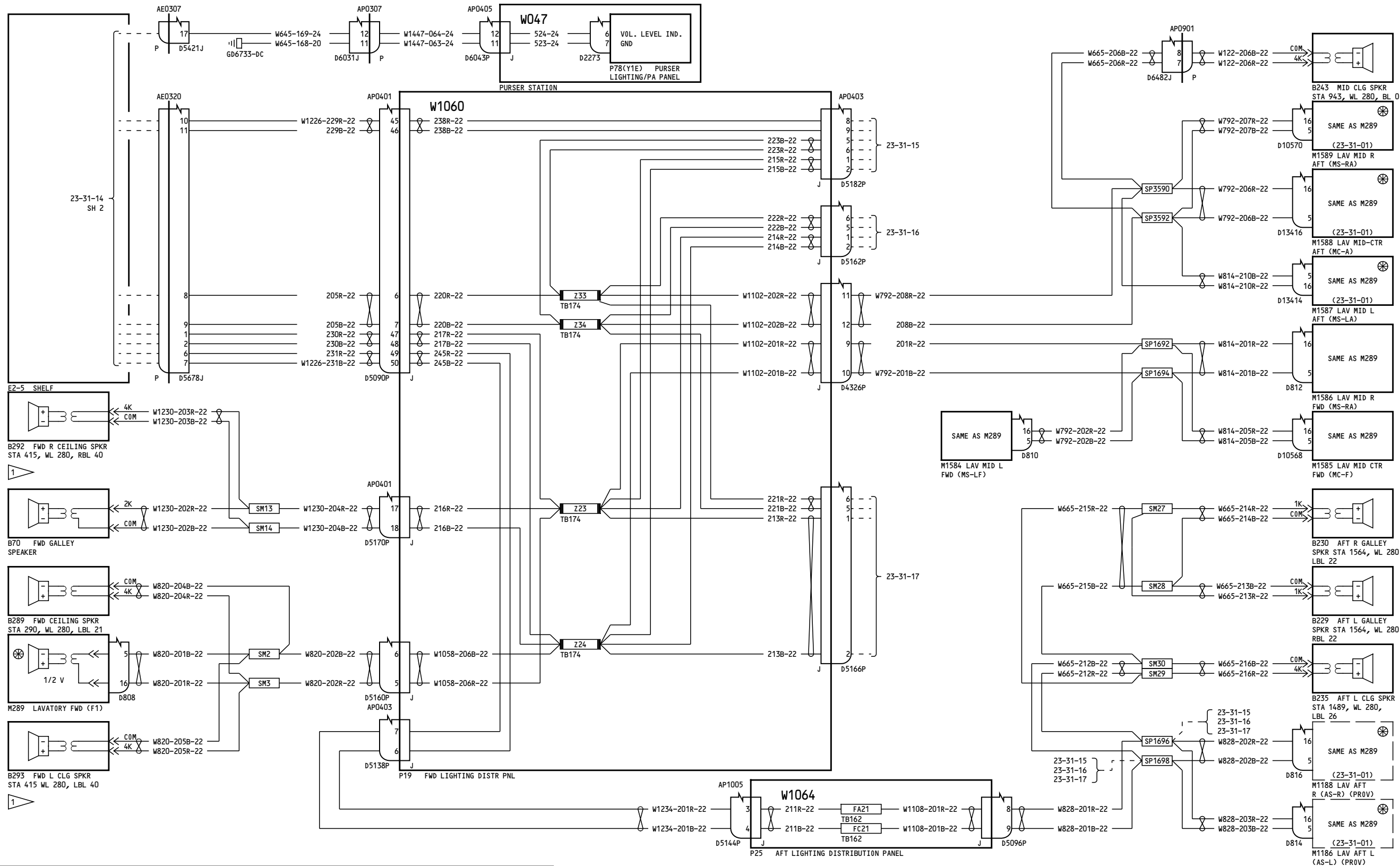

151-153

PASSENGER ADDRESS-SPEAKERS-ATTENDANT, GALLEY & LAVATORY

D280T132

23-31-14

Page 4A
Sheet 1
Jan 21/2005

23-31-14

Page 4A
Sheet 1
Jan 21/2005

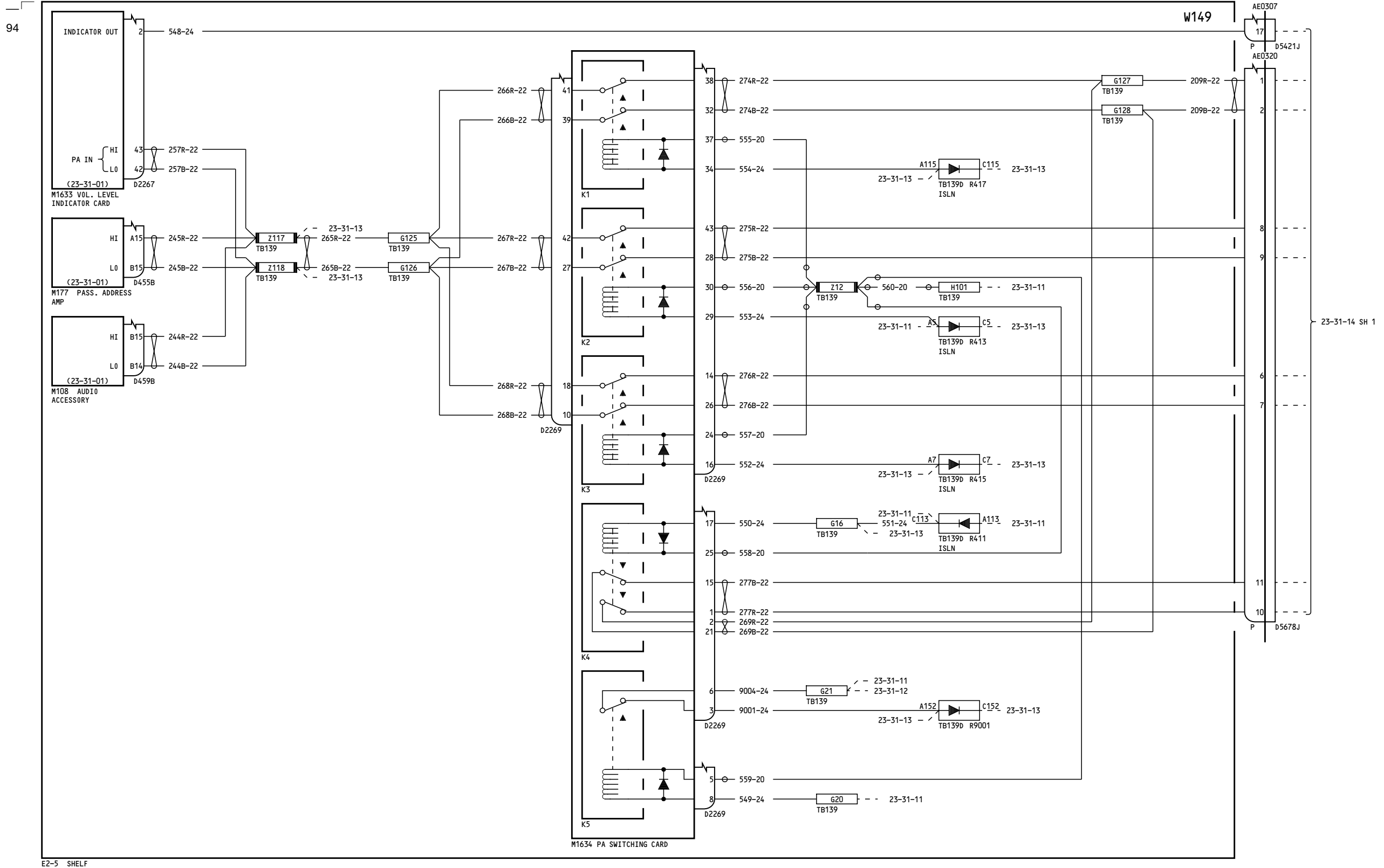

151-153

PASSENGER ADDRESS-SPEAKERS-ATTENDANT, GALLEY & LAVATORY

D280T132

23-31-14

Page 4A
Sheet 2
Jan 21/2005

Incorporates
MTO 230452A

23-31-14

Page 4A
Sheet 2
Jan 21/2005

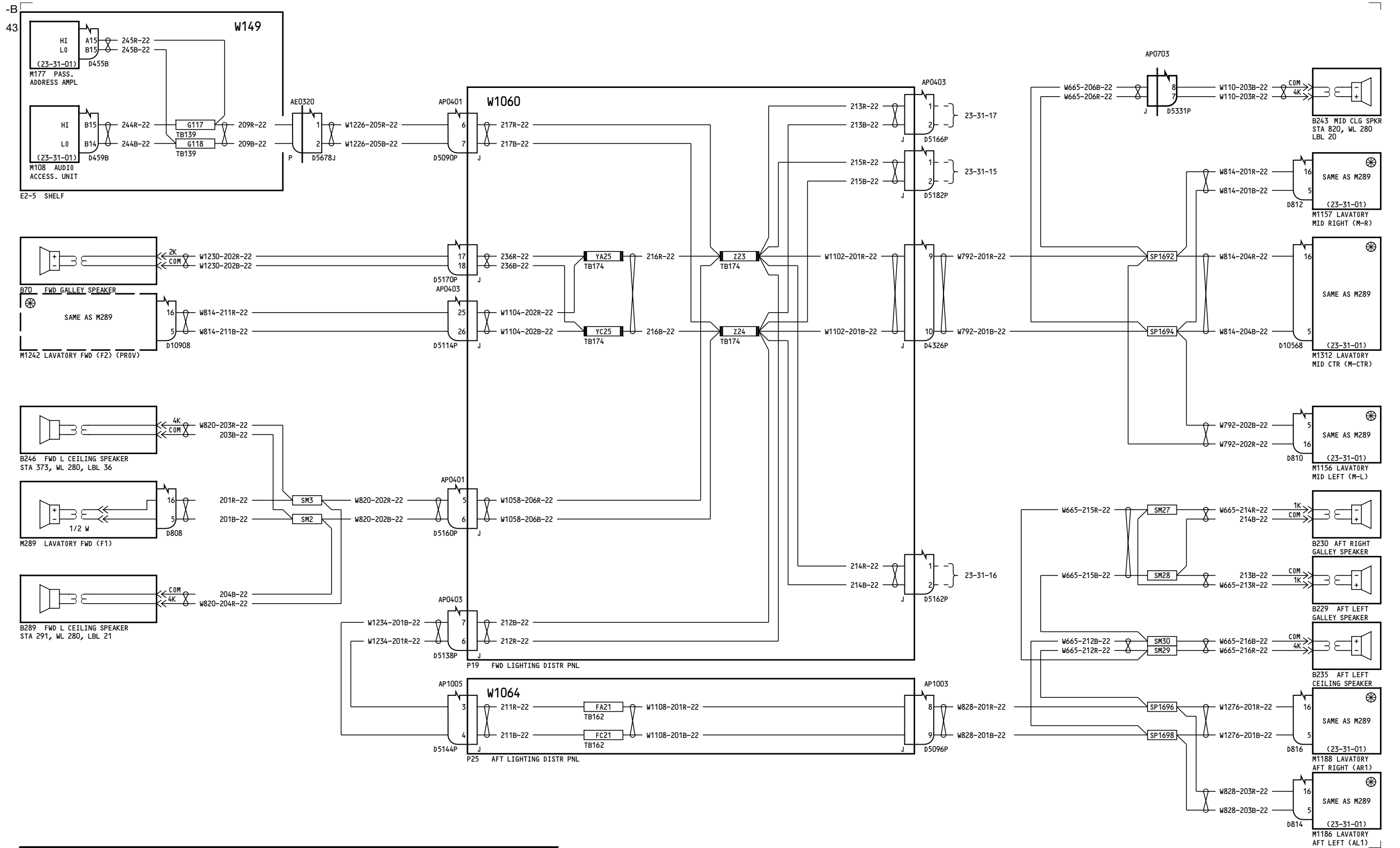

275-278

PASSENGER ADDRESS-SPEAKERS-ATTENDANT, GALLEY & LAVATORY

D280T132

23-31-14

Page 5

Jan 21/2005

23-31-14

Page 5

Jan 21/2005

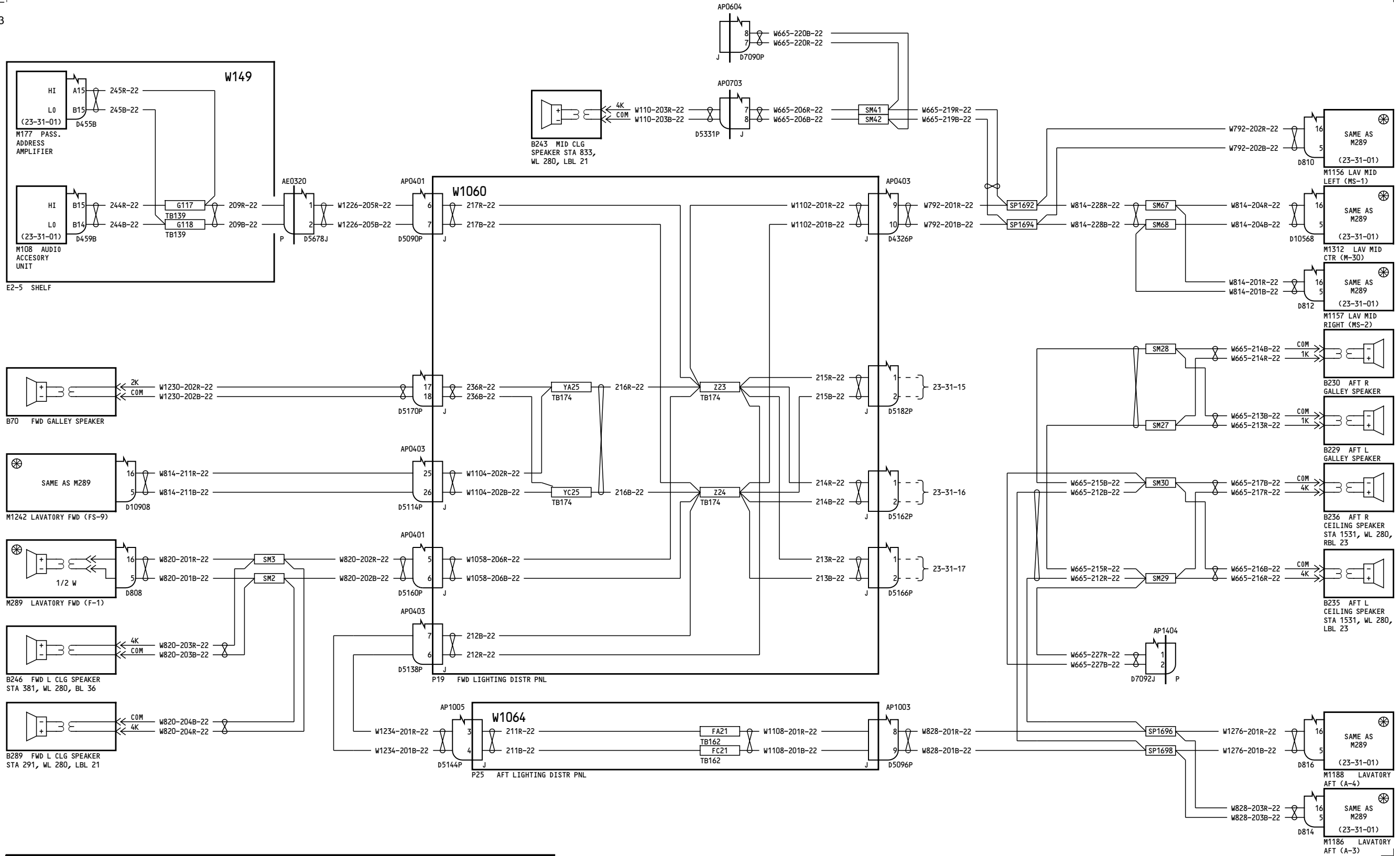

280-299

PASSENGER ADDRESS-SPEAKERS-ATTENDANT, GALLEY & LAVATORY

D280T132

23-31-14

Page 6

Jan 21/2005

23-31-14

Page 6

Jan 21/2005

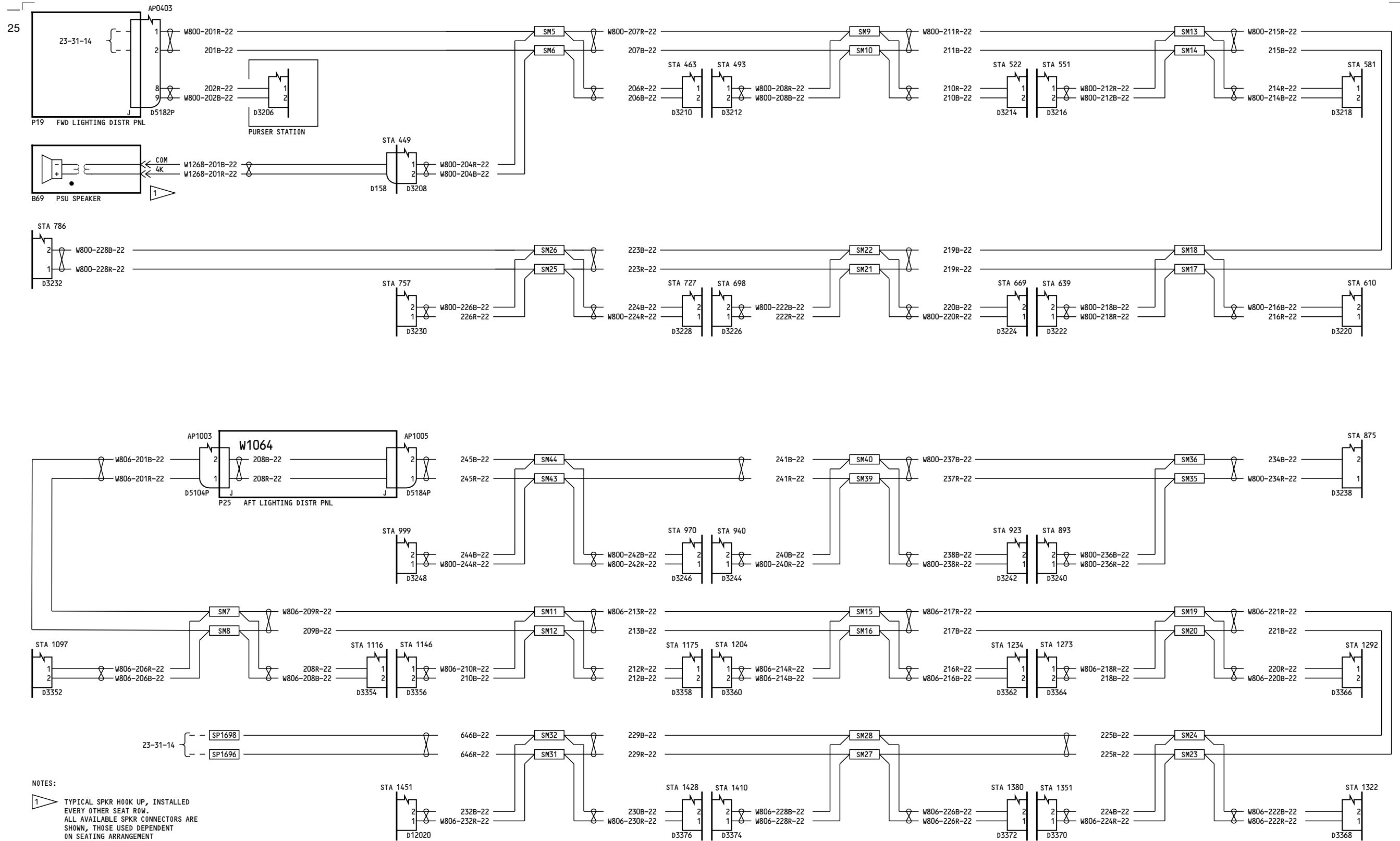

NOTES:
 1 TYPICAL SPKR HOOK UP, INSTALLED EVERY OTHER SEAT ROW. ALL AVAILABLE SPKR CONNECTORS ARE SHOWN, THOSE USED DEPENDENT ON SEATING ARRANGEMENT

050-099

PASSENGER ADDRESS-SPEAKERS-LEFT PSU SECTION

D280T132

23-31-15

Page 1
Sheet 1
Jan 21/2005

23-31-15

Page 1
Sheet 1
Jan 21/2005

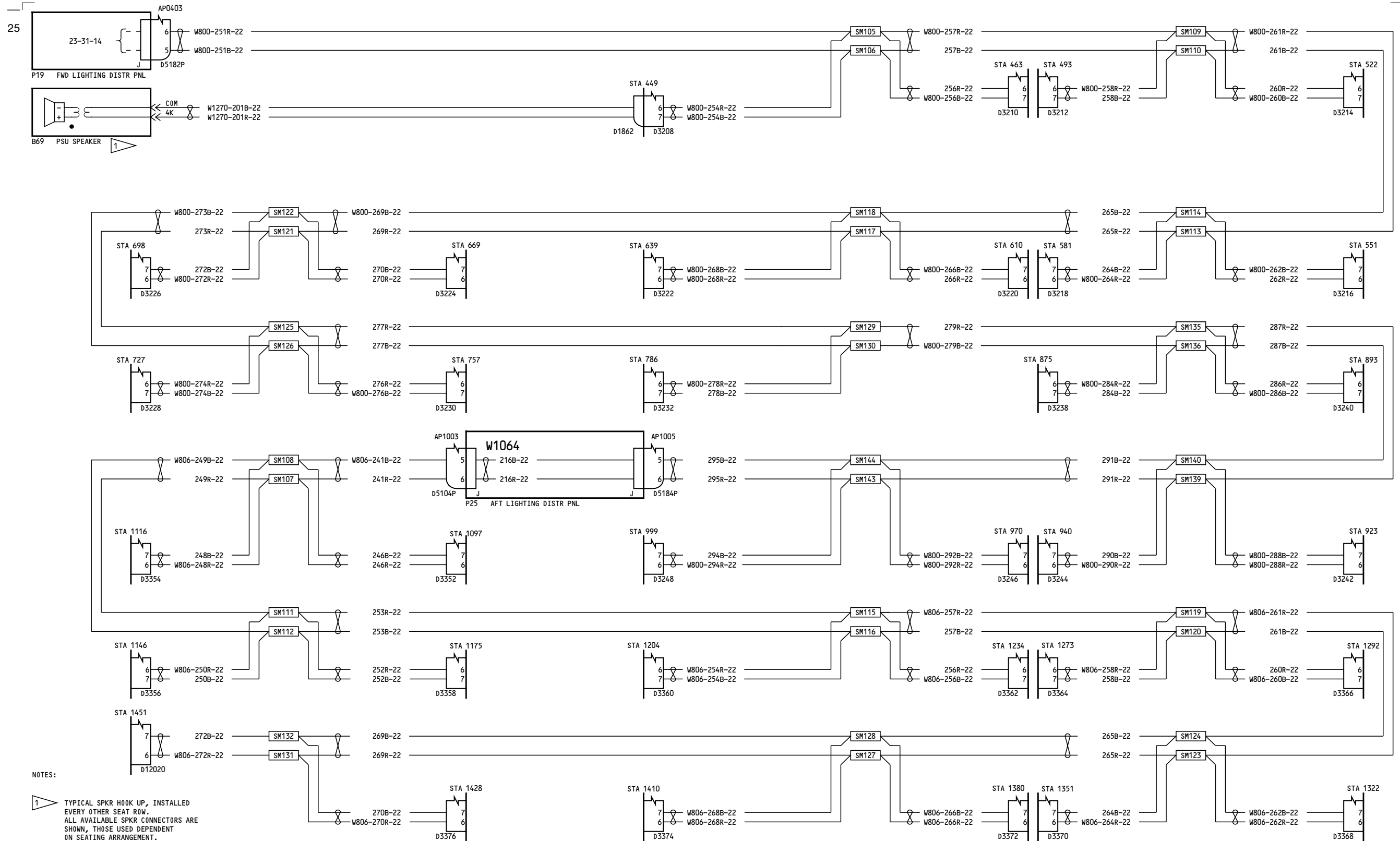

NOTES:
 1 TYPICAL SPKR HOOK UP, INSTALLED EVERY OTHER SEAT ROW. ALL AVAILABLE SPKR CONNECTORS ARE SHOWN, THOSE USED DEPENDENT ON SEATING ARRANGEMENT.

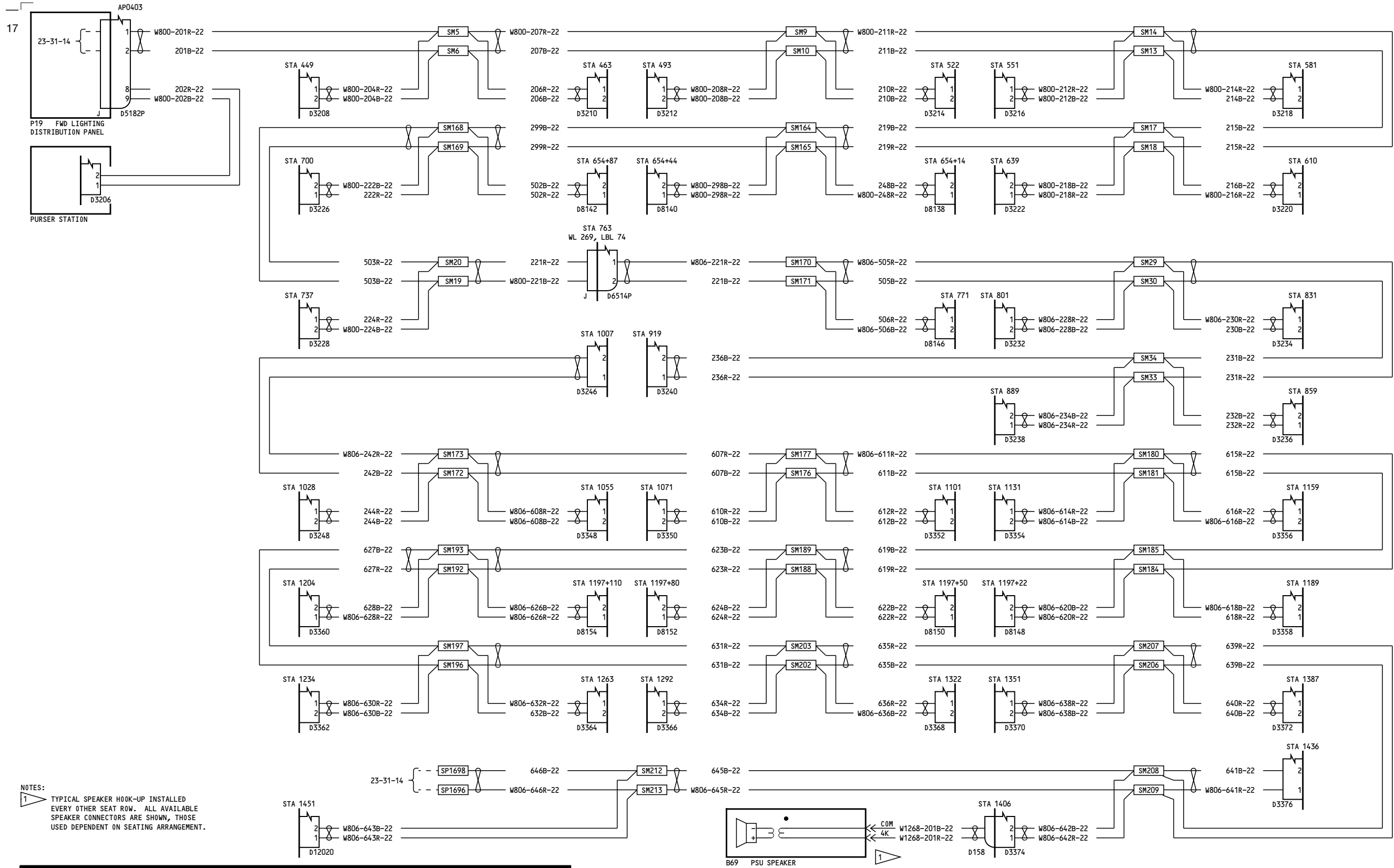

NOTES:
 1 TYPICAL SPEAKER HOOK-UP INSTALLED EVERY OTHER SEAT ROW. ALL AVAILABLE SPEAKER CONNECTORS ARE SHOWN, THOSE USED DEPENDENT ON SEATING ARRANGEMENT.

150-199	PASSENGER ADDRESS-SPEAKERS-LEFT PSU SECTION	23-31-15	23-31-15
	D280T132	Page 2 Sheet 1 Jan 21/2005	Page 2 Sheet 1 Jan 21/2005

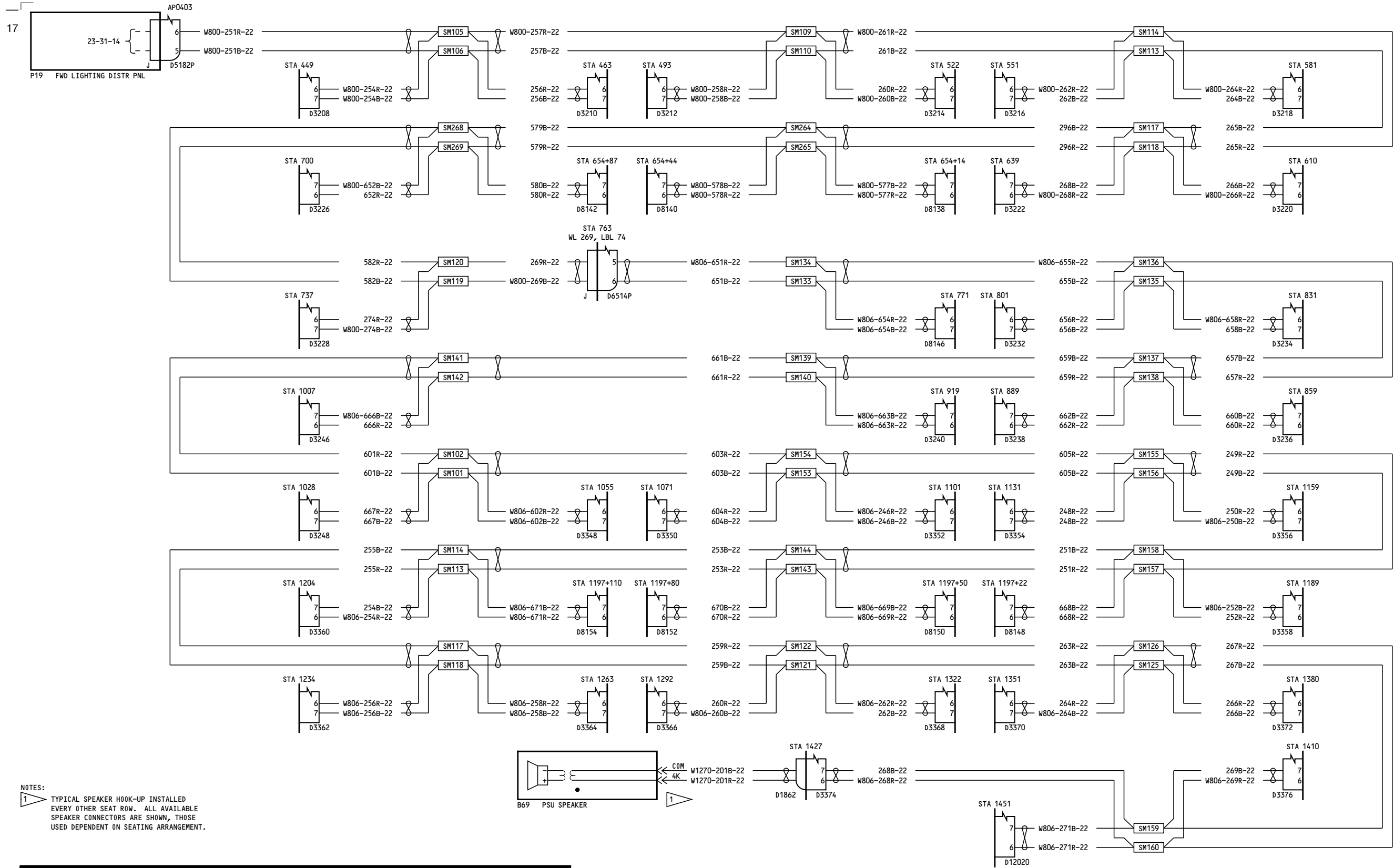

150-199

PASSENGER ADDRESS-SPEAKERS-LEFT PSU SECTION

D280T132

23-31-15

Page 2
 Sheet 2
 Jan 21/2005

23-31-15

Page 2
 Sheet 2
 Jan 21/2005

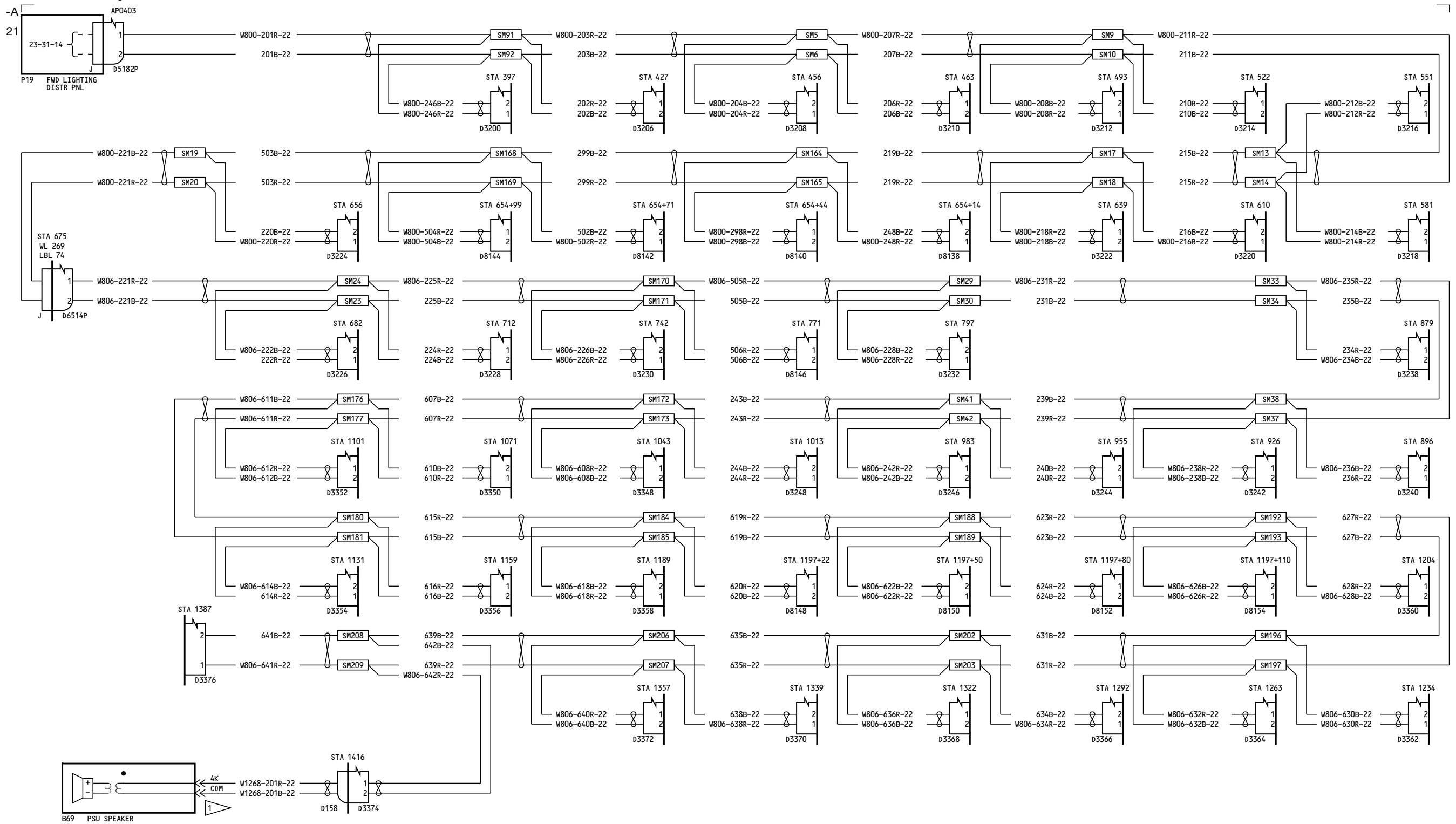

NOTES:
 1 TYPICAL SPEAKER HOOK-UP INSTALLED EVERY OTHER SEAT ROW. ALL AVAILABLE SPEAKER CONNECTORS ARE SHOWN, THOSE USED DEPENDENT ON SEATING ARRANGEMENT.

275-278

PASSENGER ADDRESS-SPEAKERS-LEFT PSU SECTION

23-31-15

Page 3

D280T132

Jan 21/2005

23-31-15

Page 3

Jan 21/2005

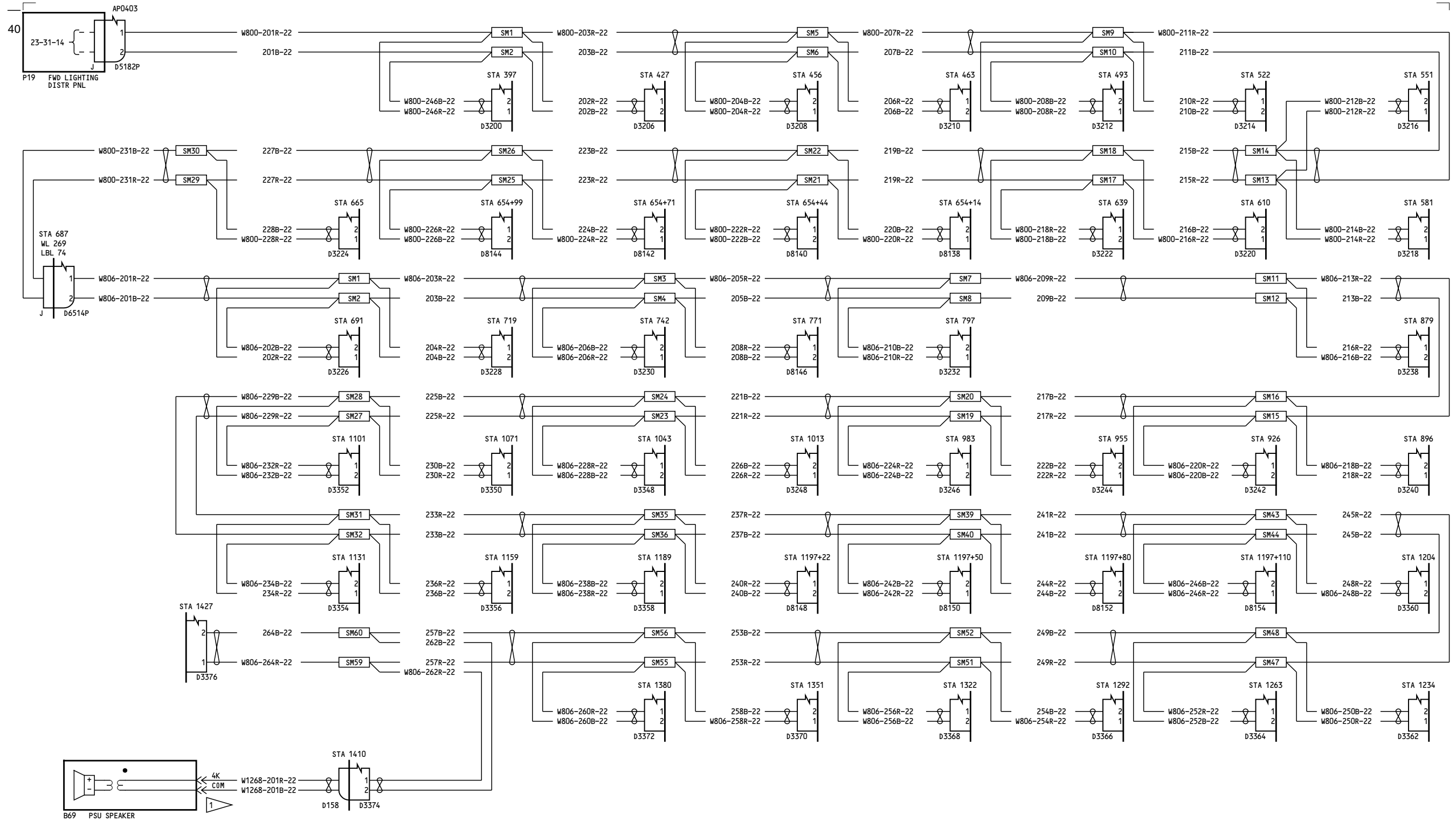

NOTES:
 1 TYPICAL SPEAKER HOOK-UP INSTALLED EVERY OTHER SEAT ROW. ALL AVAILABLE SPEAKER CONNECTORS ARE SHOWN, THOSE USED DEPENDENT ON SEATING ARRANGEMENT.

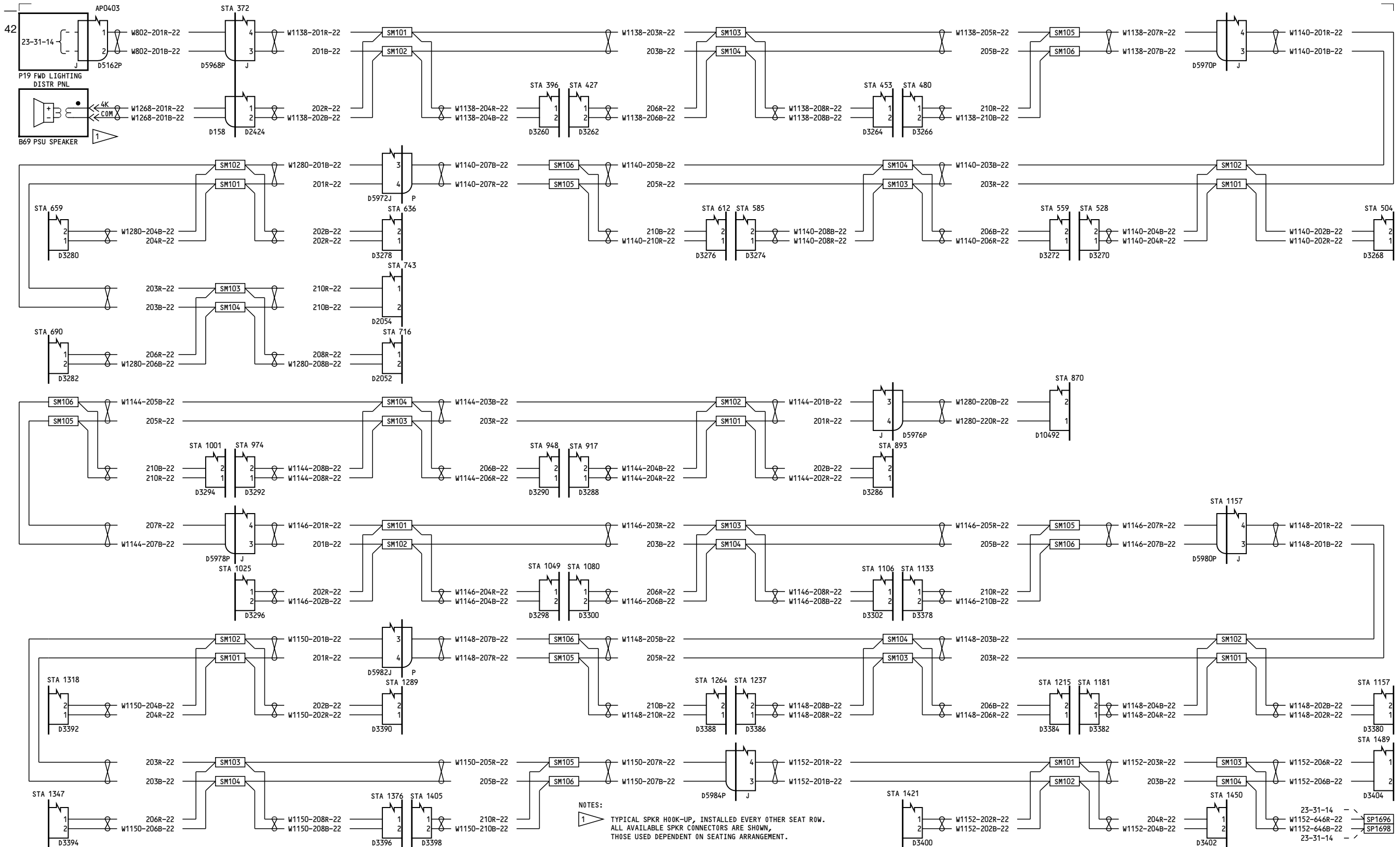

NOTES:
 1 TYPICAL SPKR HOOK-UP, INSTALLED EVERY OTHER SEAT ROW.
 ALL AVAILABLE SPKR CONNECTORS ARE SHOWN,
 THOSE USED DEPENDENT ON SEATING ARRANGEMENT.

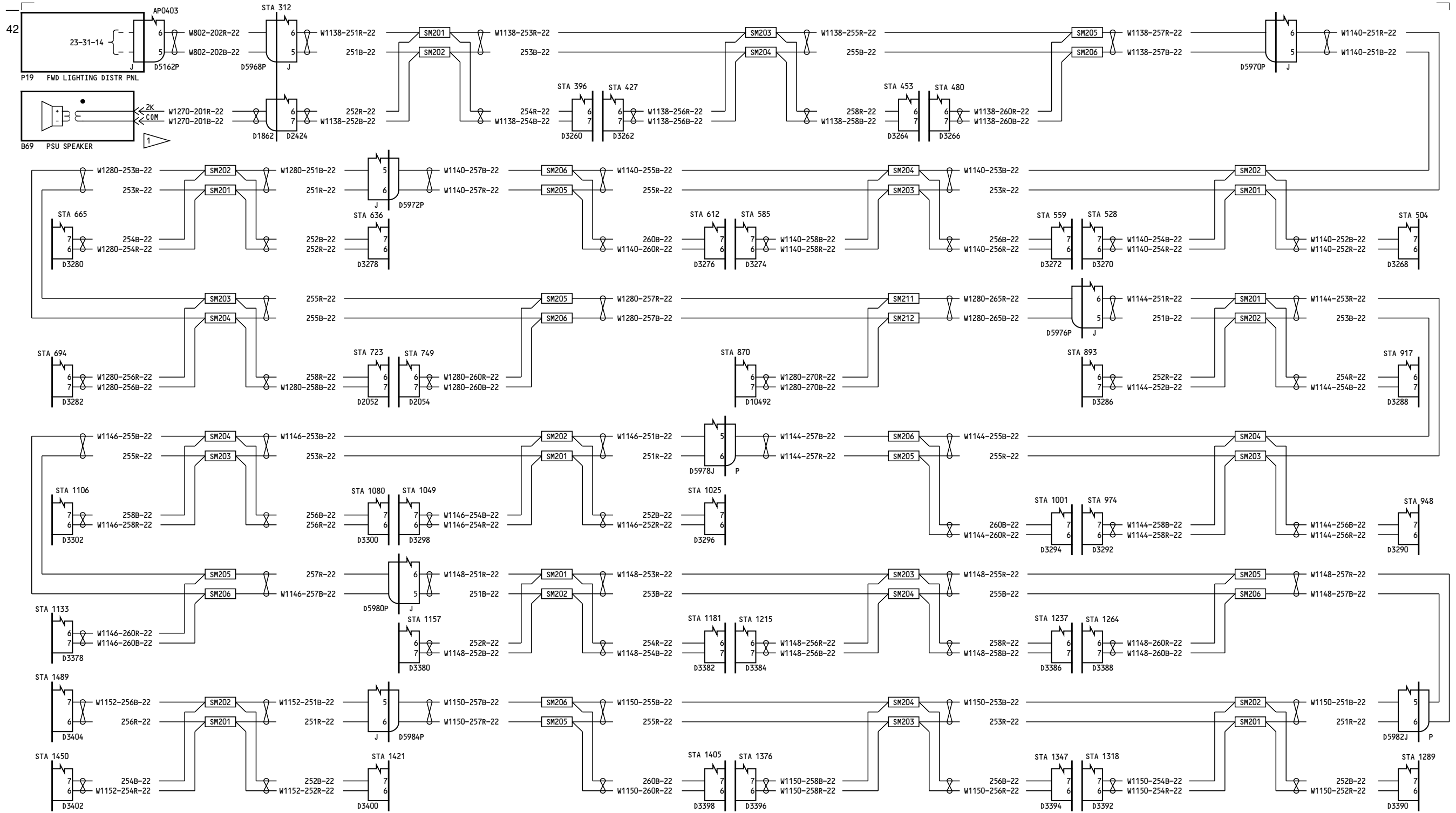

NOTES:
 1 TYPICAL SPKR HOOK UP, INSTALLED EVERY OTHER SEAT ROW.
 ALL AVAILABLE SPKR CONNECTORS ARE SHOWN,
 THOSE USED DEPENDENT ON SEATING ARRANGEMENT

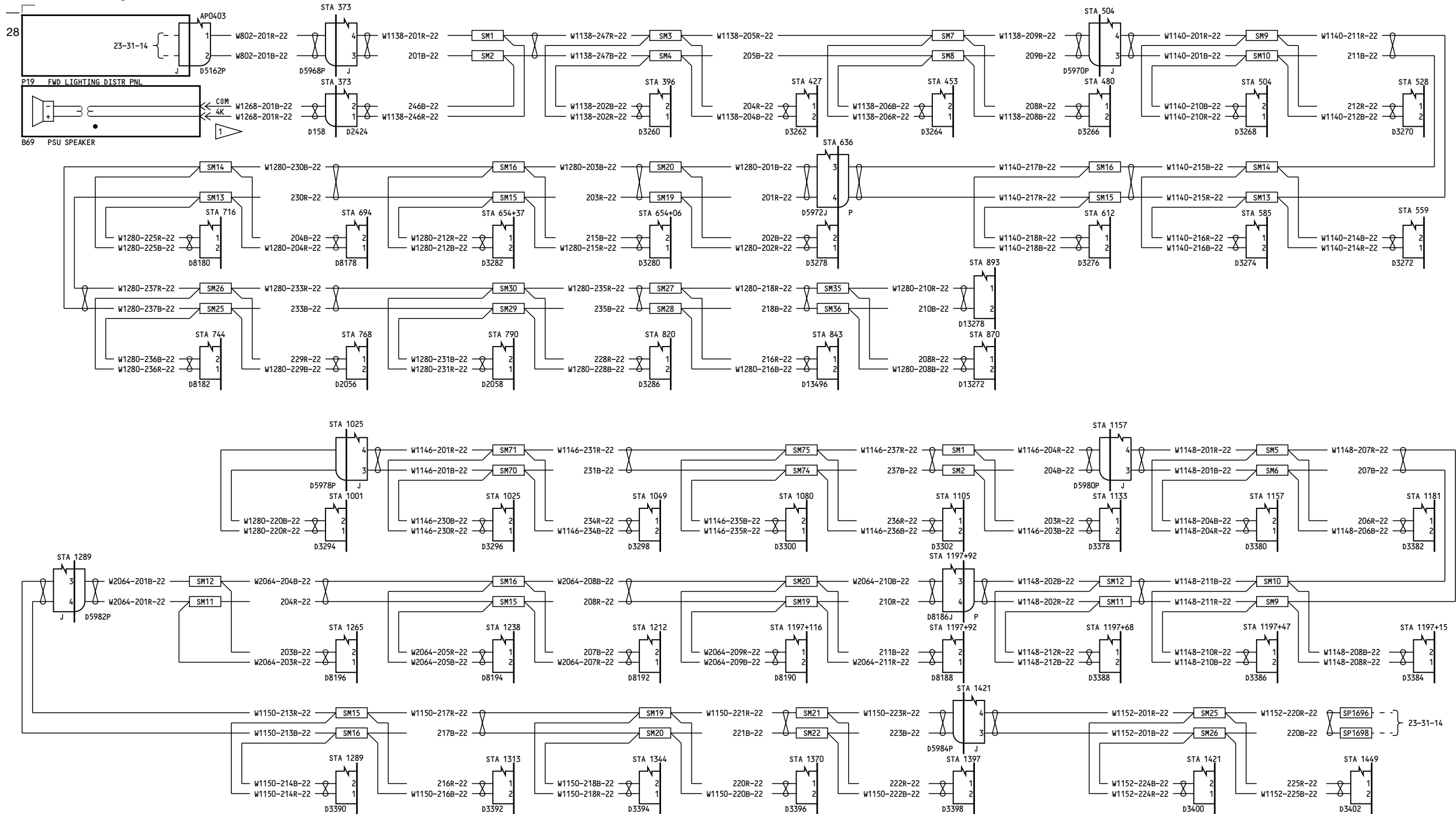

NOTES:
 1 TYPICAL SPEAKER HOOK-UP INSTALLED EVERY OTHER SEAT ROW. ALL AVAILABLE SPEAKER CONNECTORS ARE SHOWN, THOSE USED DEPEND-ENT ON SEATING ARRANGEMENT.

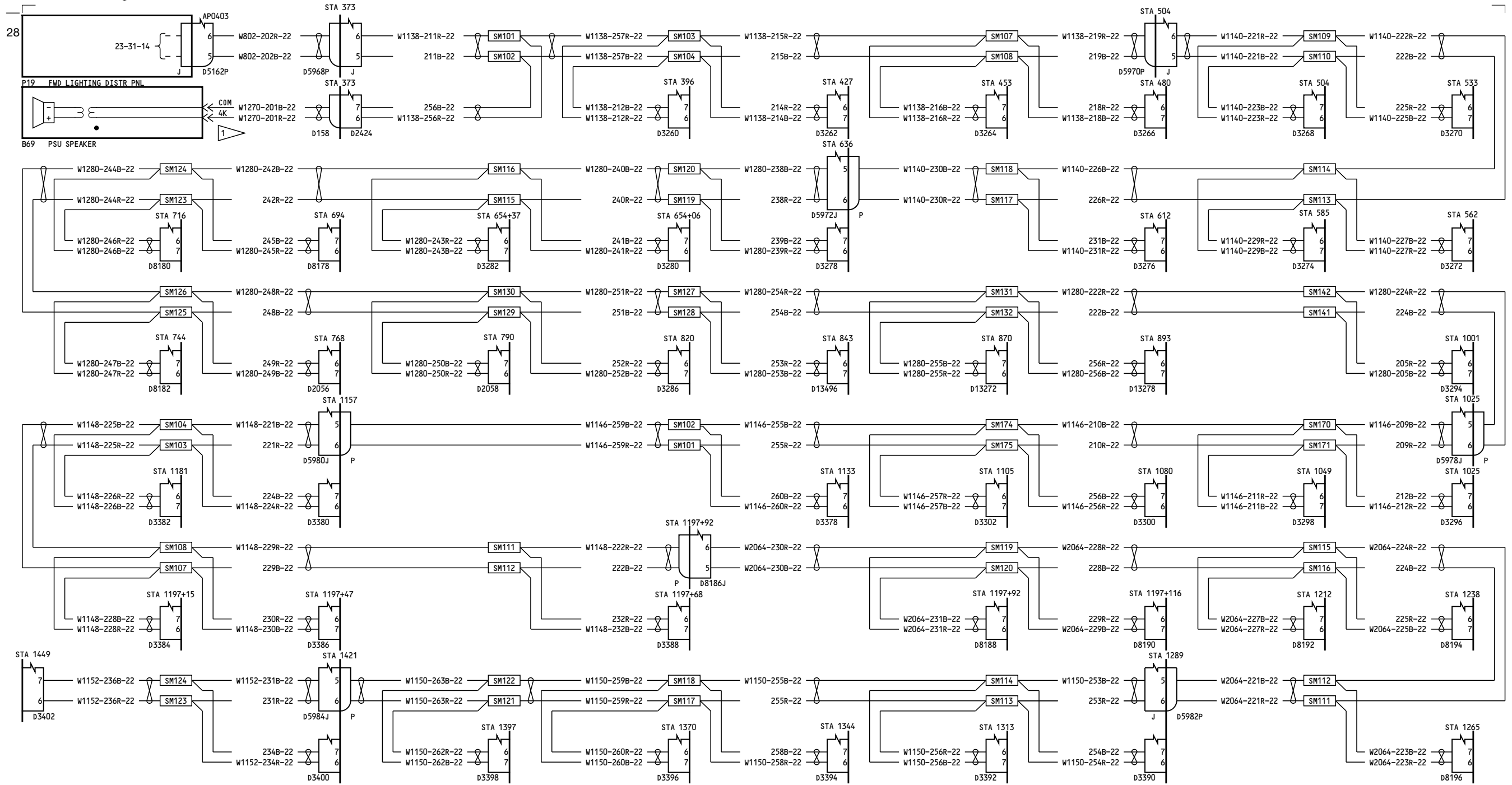

NOTES:
 1 TYPICAL SPEAKER HOOK-UP INSTALLED EVERY OTHER SEAT ROW. ALL AVAILABLE SPEAKER CONNECTORS ARE SHOWN, THOSE USED DEPEND-ENT ON SEATING ARRANGEMENT.

150-199

PASSENGER ADDRESS-SPEAKERS-CENTER PSU SECTION

D280T132

23-31-16

Page 2
 Sheet 2
 Jan 21/2005

23-31-16

Page 2
 Sheet 2
 Jan 21/2005

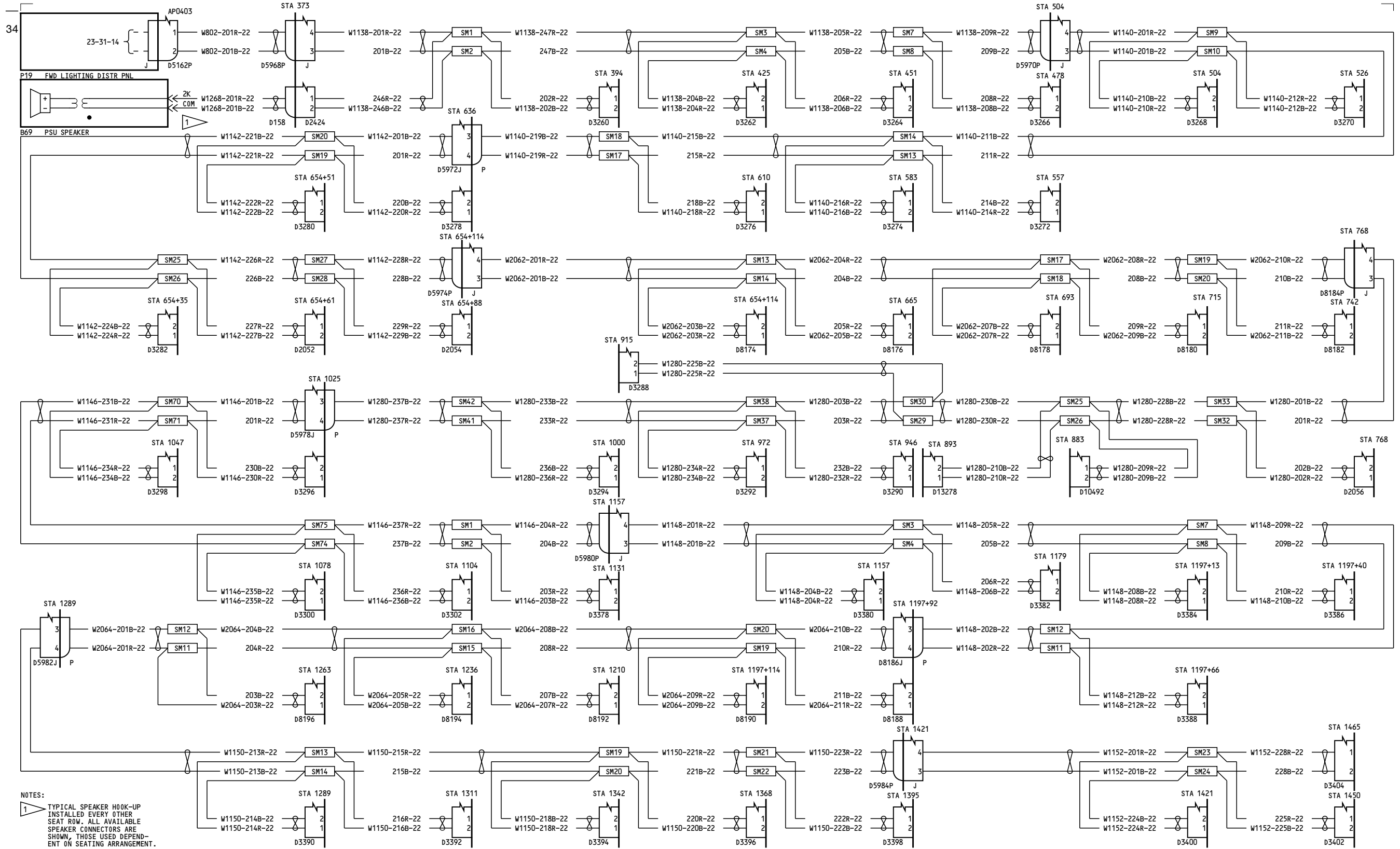

NOTES:
 1 TYPICAL SPEAKER HOOK-UP INSTALLED EVERY OTHER SEAT ROW. ALL AVAILABLE SPEAKER CONNECTORS ARE SHOWN, THOSE USED DEPENDENT ON SEATING ARRANGEMENT.

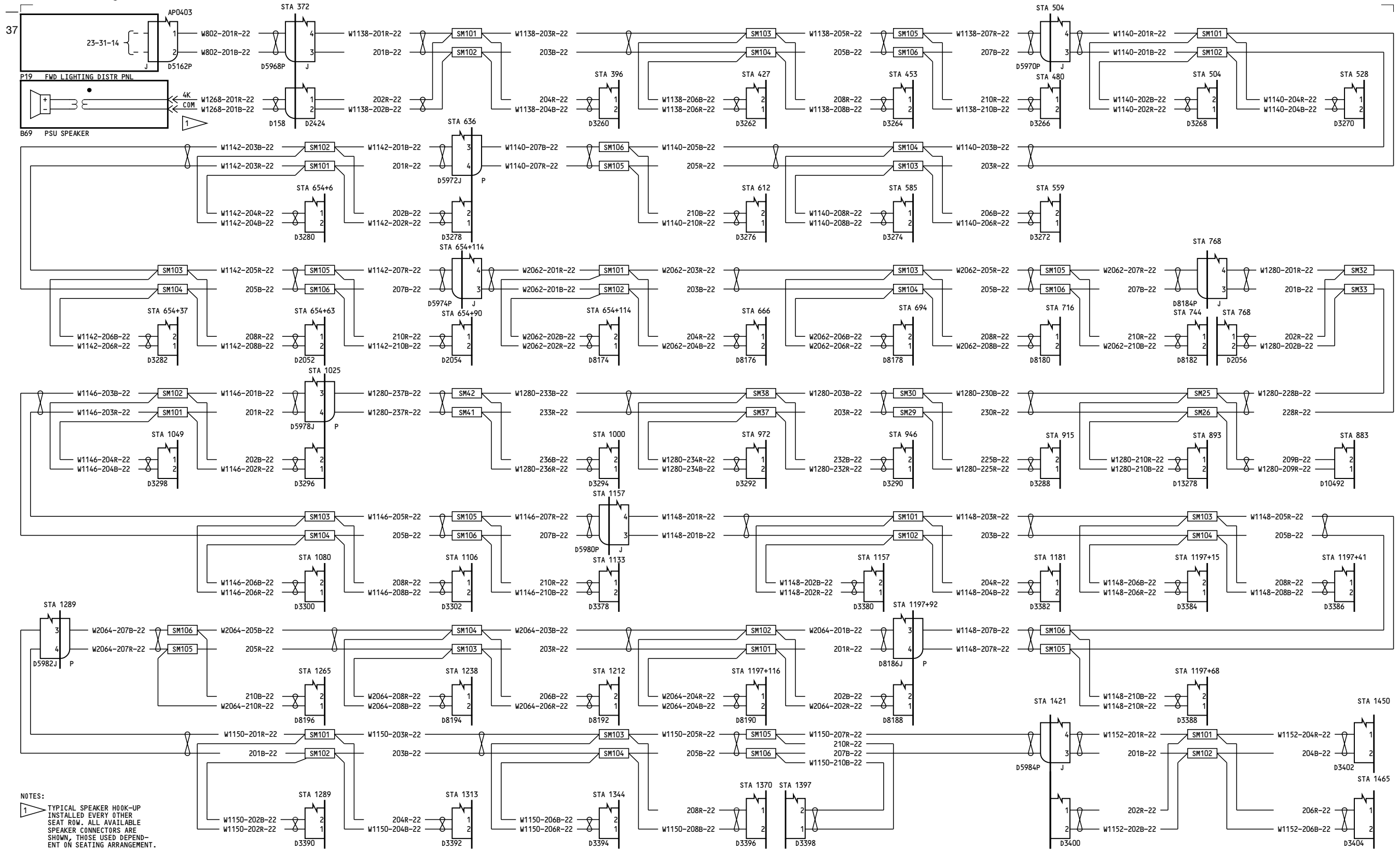

NOTES:
 1 TYPICAL SPEAKER HOOK-UP
 INSTALLED EVERY OTHER
 SEAT ROW. ALL AVAILABLE
 SPEAKER CONNECTORS ARE
 SHOWN, THOSE USED DEPEND-
 ENT ON SEATING ARRANGEMENT.

276-278

**PASSENGER ADDRESS-
 SPEAKERS-
 CENTER PSU SECTION**

23-31-16

Page 4

D280T132

Jan 21/2005

23-31-16

Page 4

Jan 21/2005

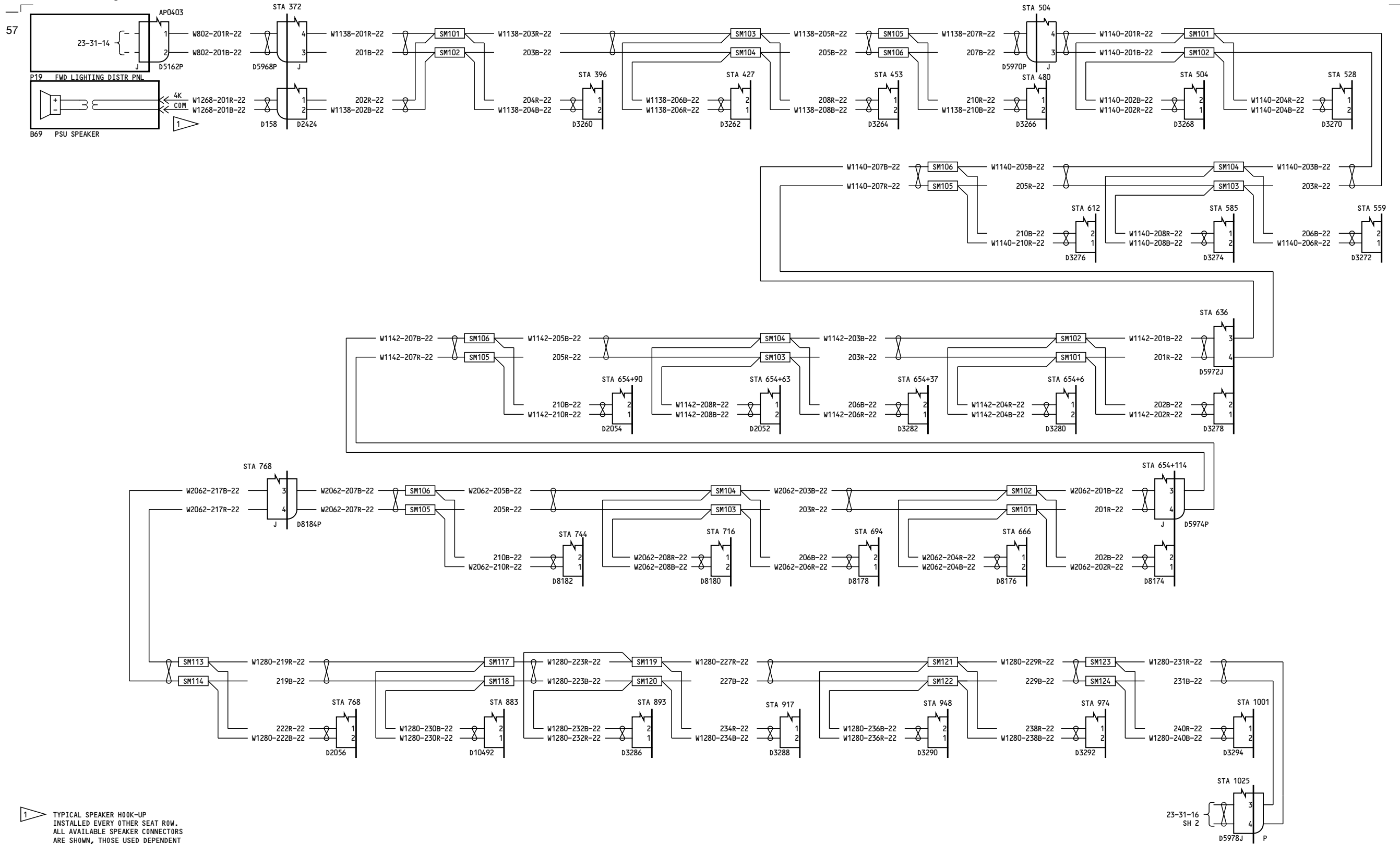

280-299

PASSENGER ADDRESS-SPEAKERS-CENTER PSU SECTION

23-31-16

Page 5
Sheet 1
Jan 21/2005

D280T132

23-31-16

Page 5
Sheet 1
Jan 21/2005

57

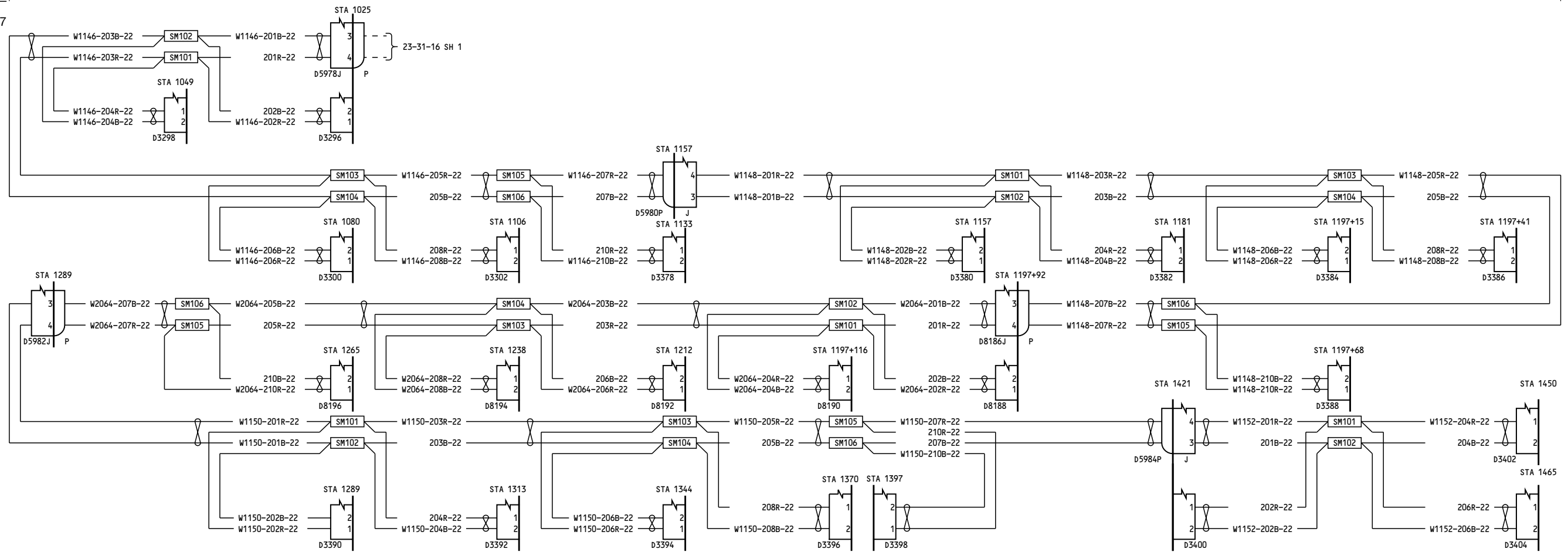

NOTES:
 1 TYPICAL SPEAKER HOOK-UP
 INSTALLED EVERY OTHER
 SEAT ROW. ALL AVAILABLE
 SPEAKER CONNECTORS ARE
 SHOWN, THOSE USED DEPEND-
 ENT ON SEATING ARRANGEMENT.

280-299

**PASSENGER ADDRESS-
 SPEAKERS-
 CENTER PSU SECTION**

D280T132

23-31-16

Page 5
 Sheet 2
 Jan 21/2005

23-31-16

Page 5
 Sheet 2
 Jan 21/2005

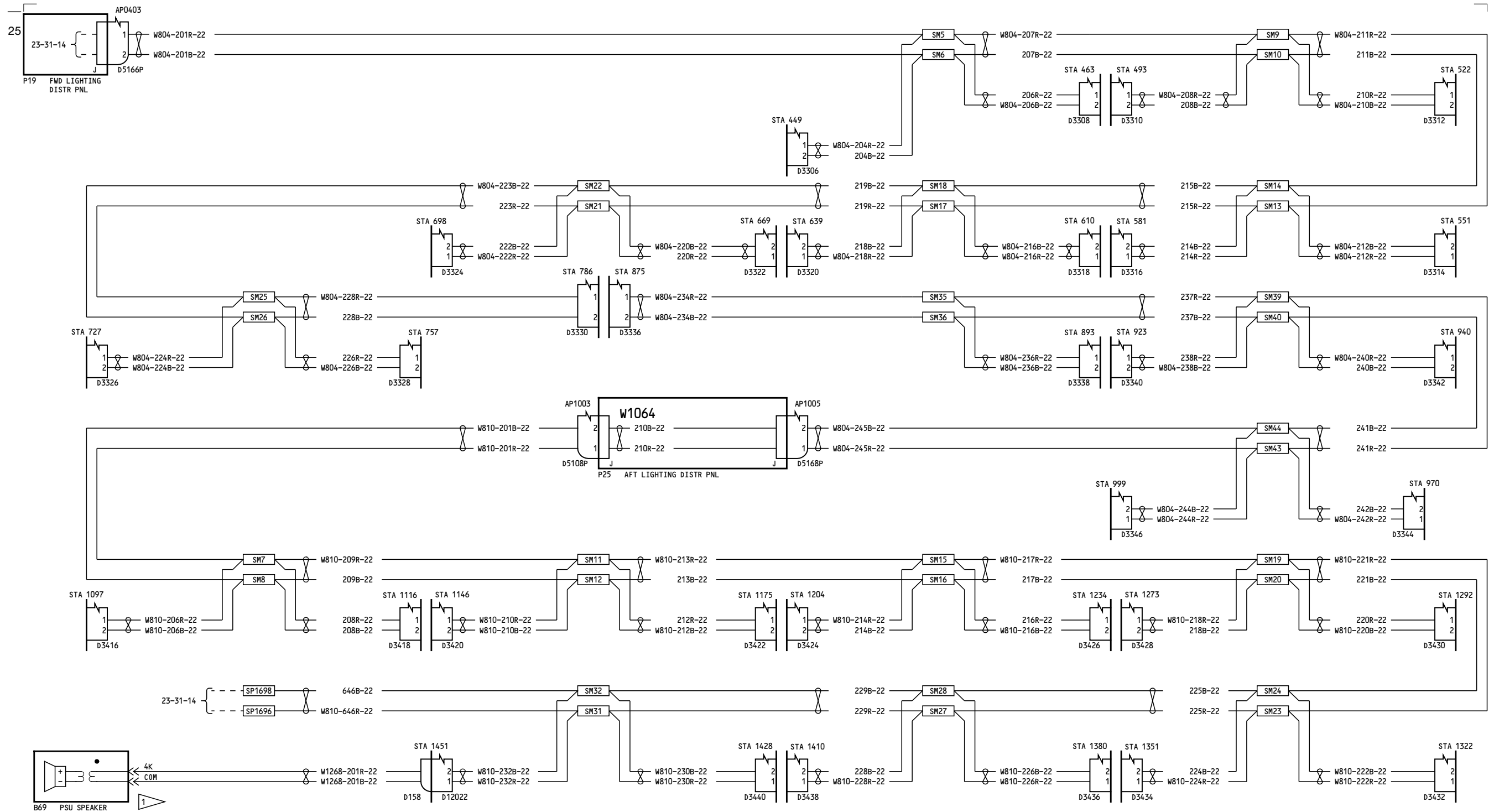

NOTES:
 1 TYPICAL SPKR HOOK UP, INSTALLED EVERY OTHER SEAT ROW. ALL AVAILABLE SPKR CONNECTORS ARE SHOWN, THOSE USED DEPENDENT ON SEATING ARRANGEMENT

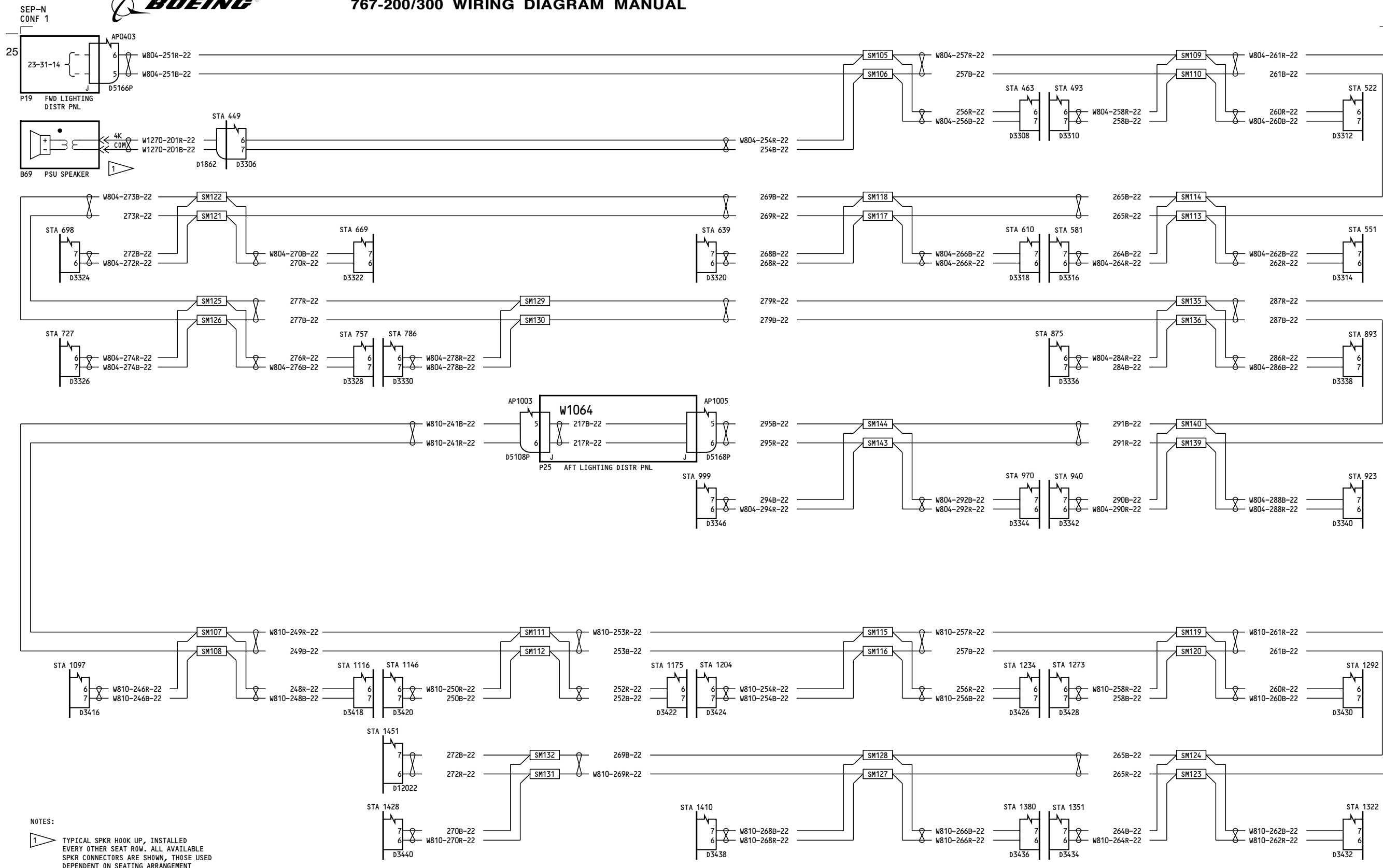

NOTES:
 1 TYPICAL SPKR HOOK UP, INSTALLED EVERY OTHER SEAT ROW. ALL AVAILABLE SPKR CONNECTORS ARE SHOWN, THOSE USED DEPENDENT ON SEATING ARRANGEMENT

050-099

PASSENGER ADDRESS-SPEAKERS-RIGHT PSU SECTION

D280T132

23-31-17

Page 1
 Sheet 2
 Jan 21/2005

23-31-17

Page 1
 Sheet 2
 Jan 21/2005

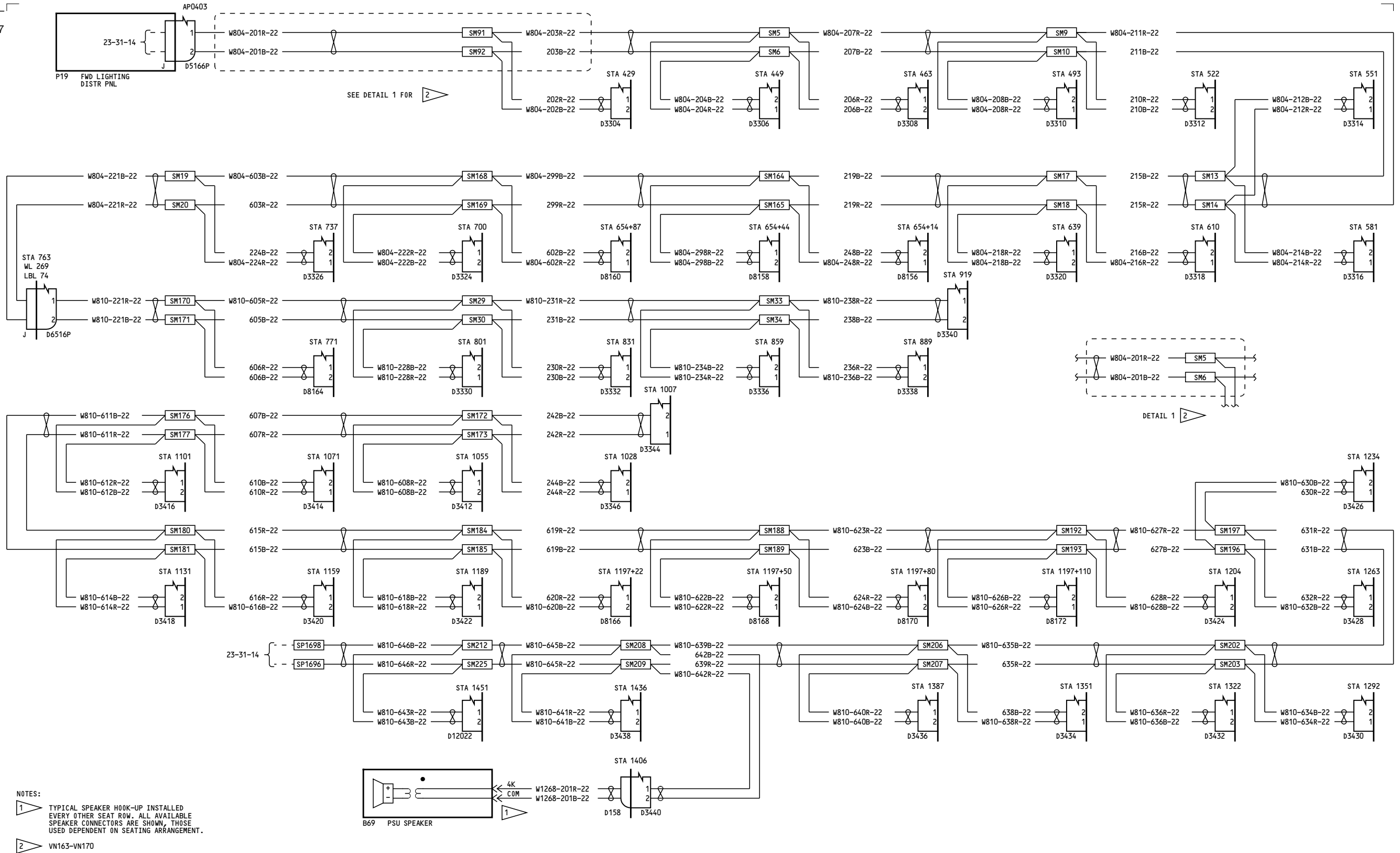

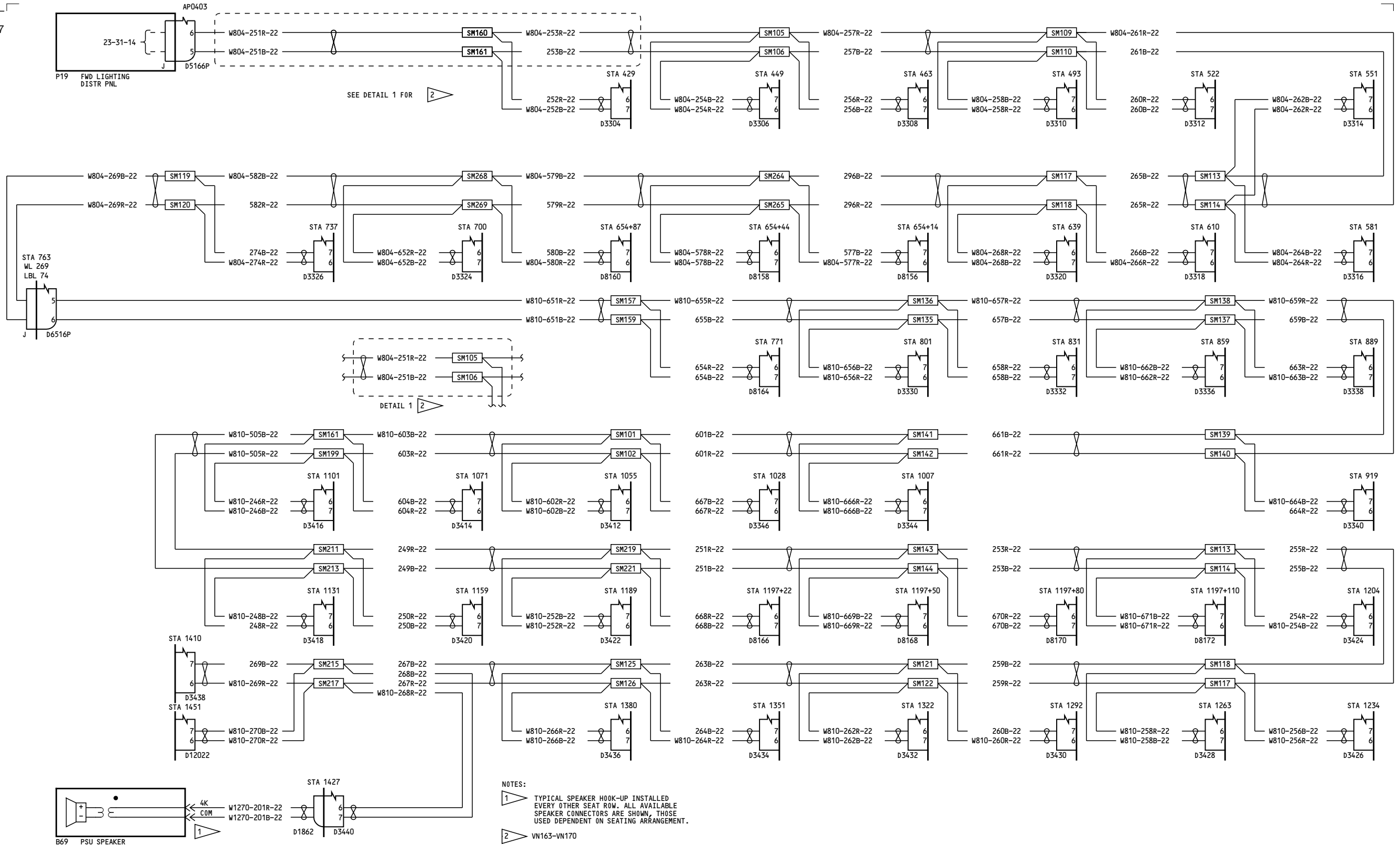

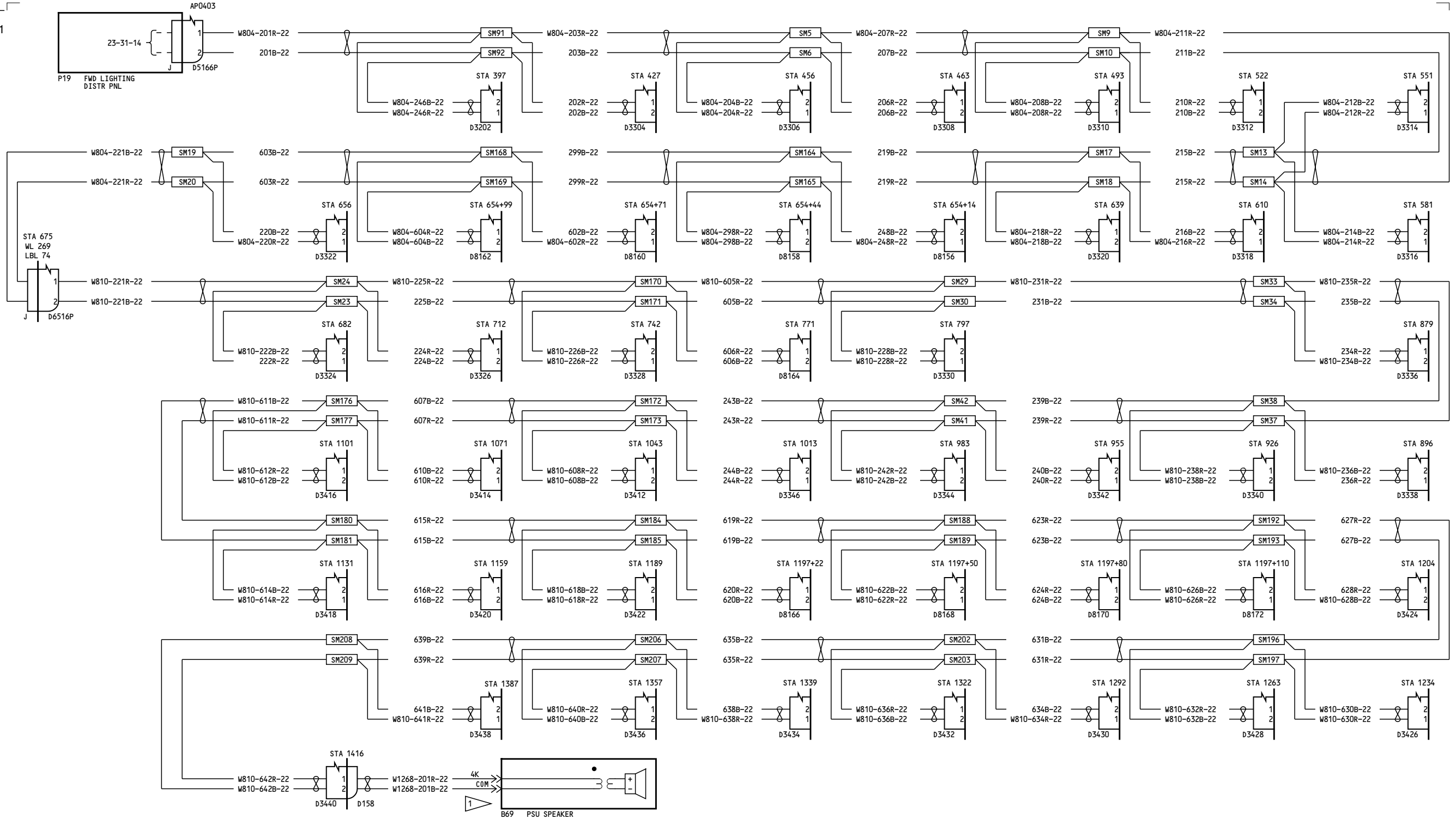

NOTES:
 1 TYPICAL SPEAKER HOOK-UP INSTALLED EVERY OTHER SEAT ROW. ALL AVAILABLE SPEAKER CONNECTORS ARE SHOWN, THOSE USED DEPENDENT ON SEATING ARRANGEMENT.

275-278

**PASSENGER ADDRESS-SPEAKERS-
 RIGHT PSU SECTION**

23-31-17

Page 3

D280T132

Jan 21/2005

23-31-17

Page 3

Jan 21/2005

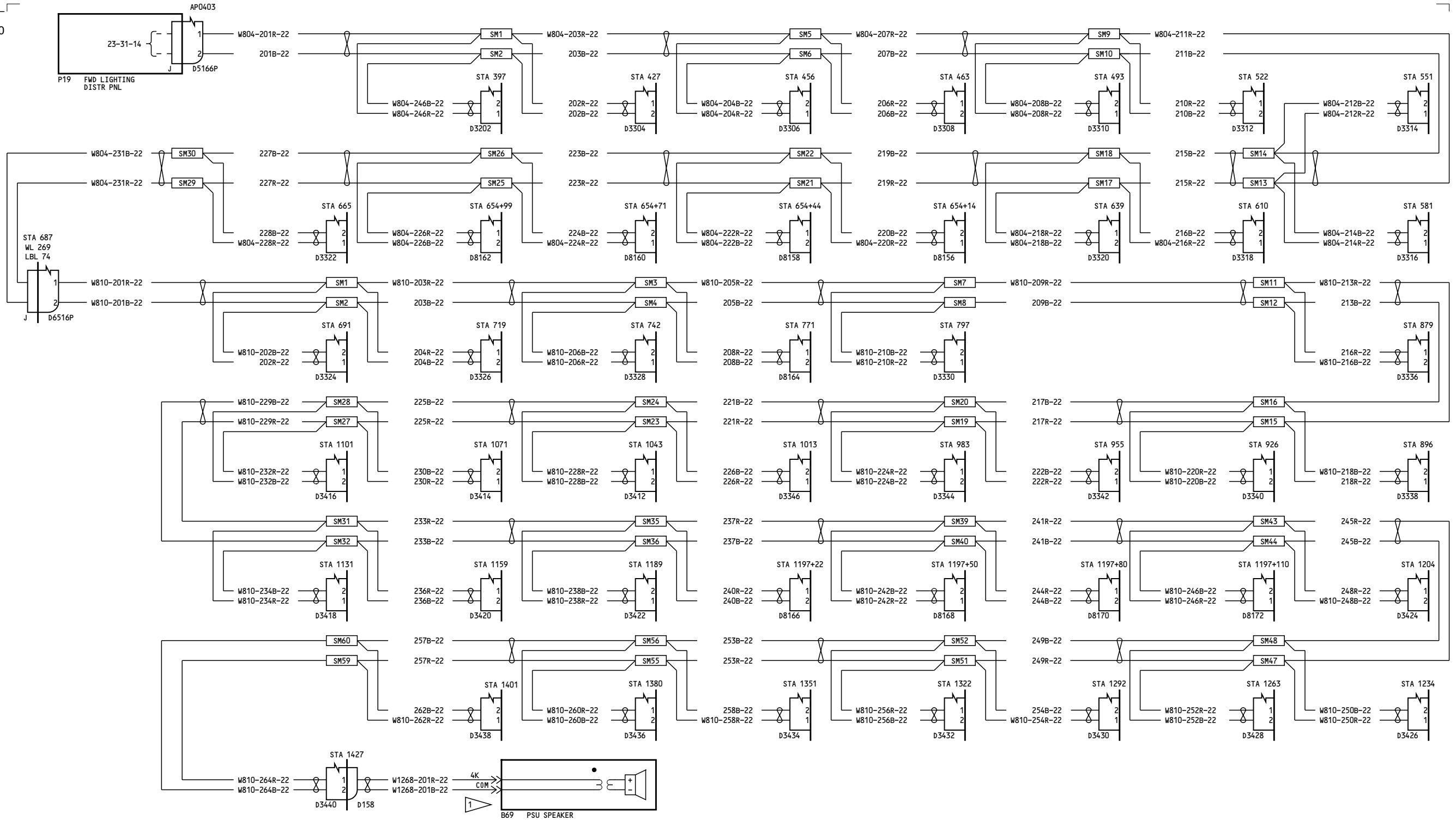

NOTES:
 1 TYPICAL SPEAKER HOOK-UP INSTALLED EVERY OTHER SEAT ROW. ALL AVAILABLE SPEAKER CONNECTORS ARE SHOWN, THOSE USED DEPENDENT ON SEATING ARRANGEMENT.

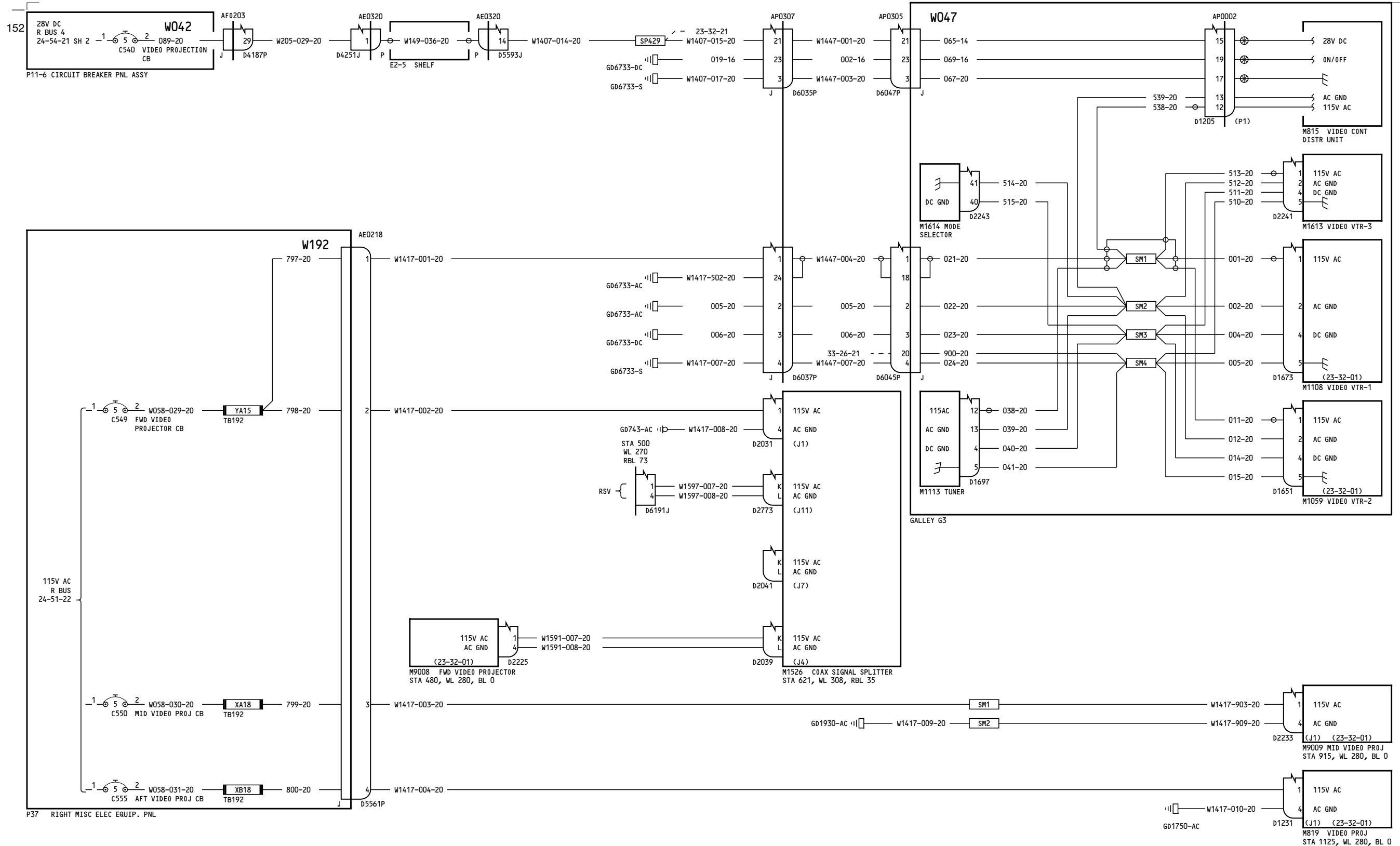

050-051

VIDEO PROJECTION-POWER

D280T132

23-32-11

Page 1A
Jan 21/2005

Incorporates
MTO 230540
MTO 330286 R01

23-32-11

Page 1A
Jan 21/2005

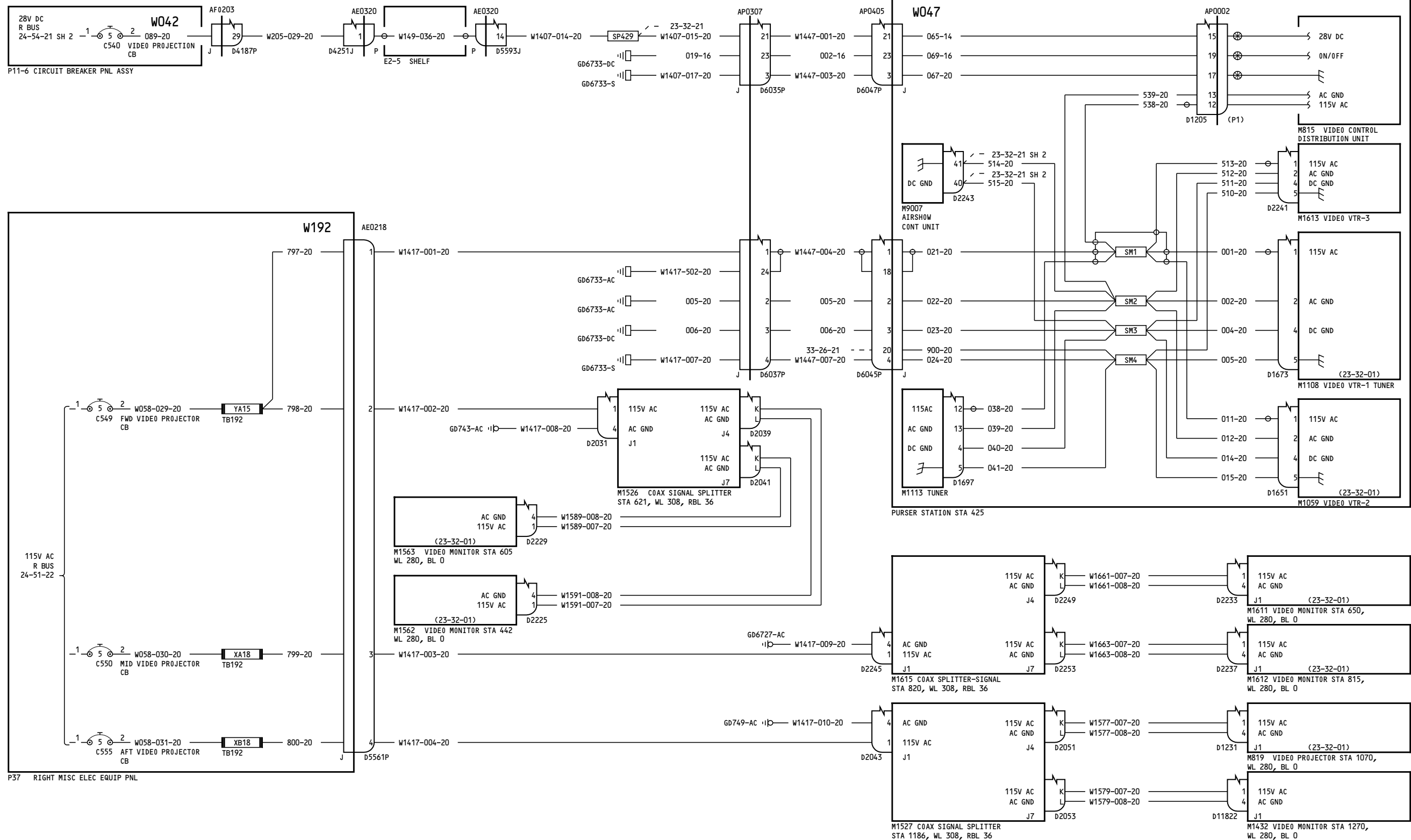

150, 153-154, 162-165

VIDEO PROJECTION-POWER

23-32-11

Page 2A

D280T132

Jan 21/2005

Incorporates

- MTO 230523
- MTO 230532
- MTO 330286
- MTO-230718

23-32-11

Page 2A

Jan 21/2005

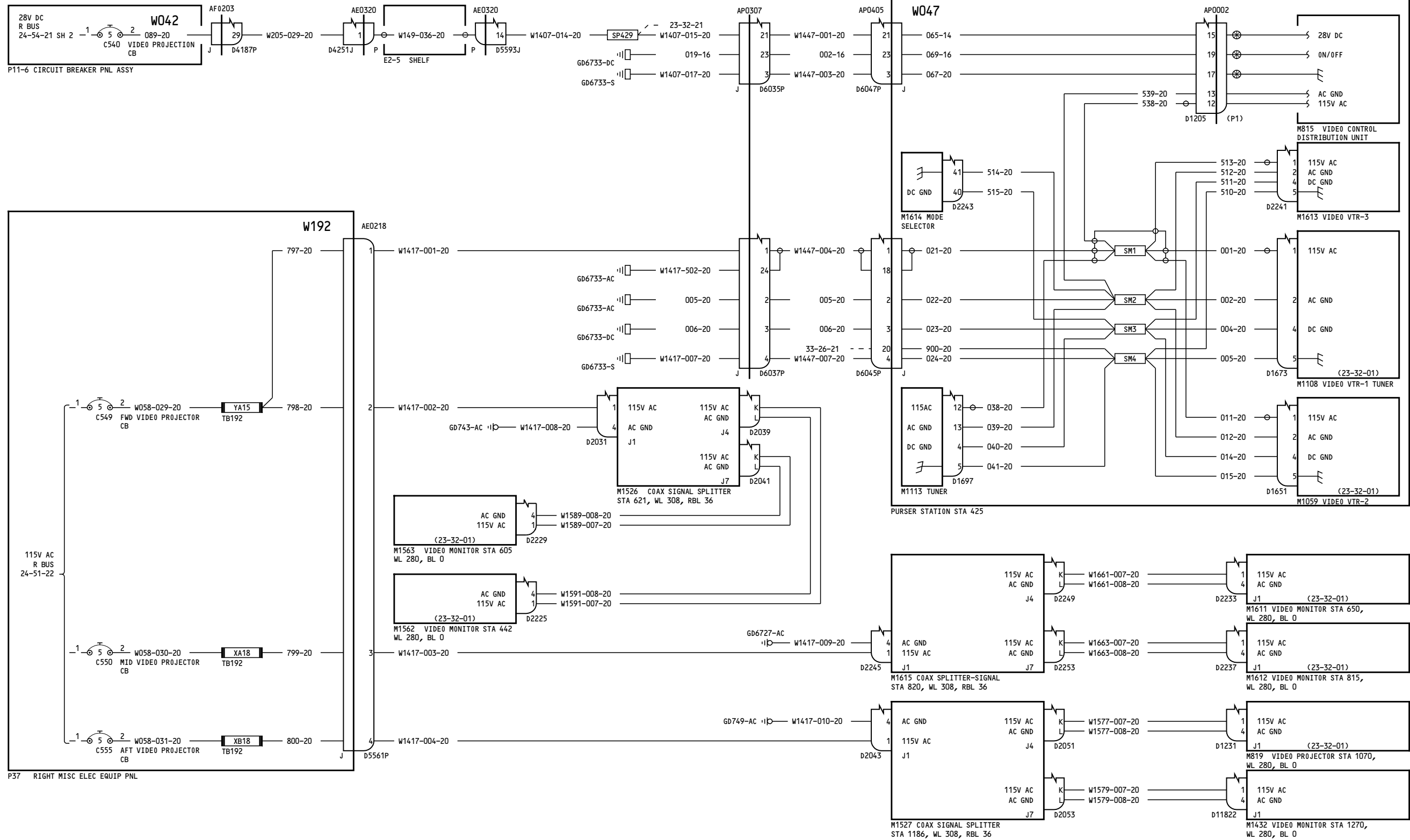

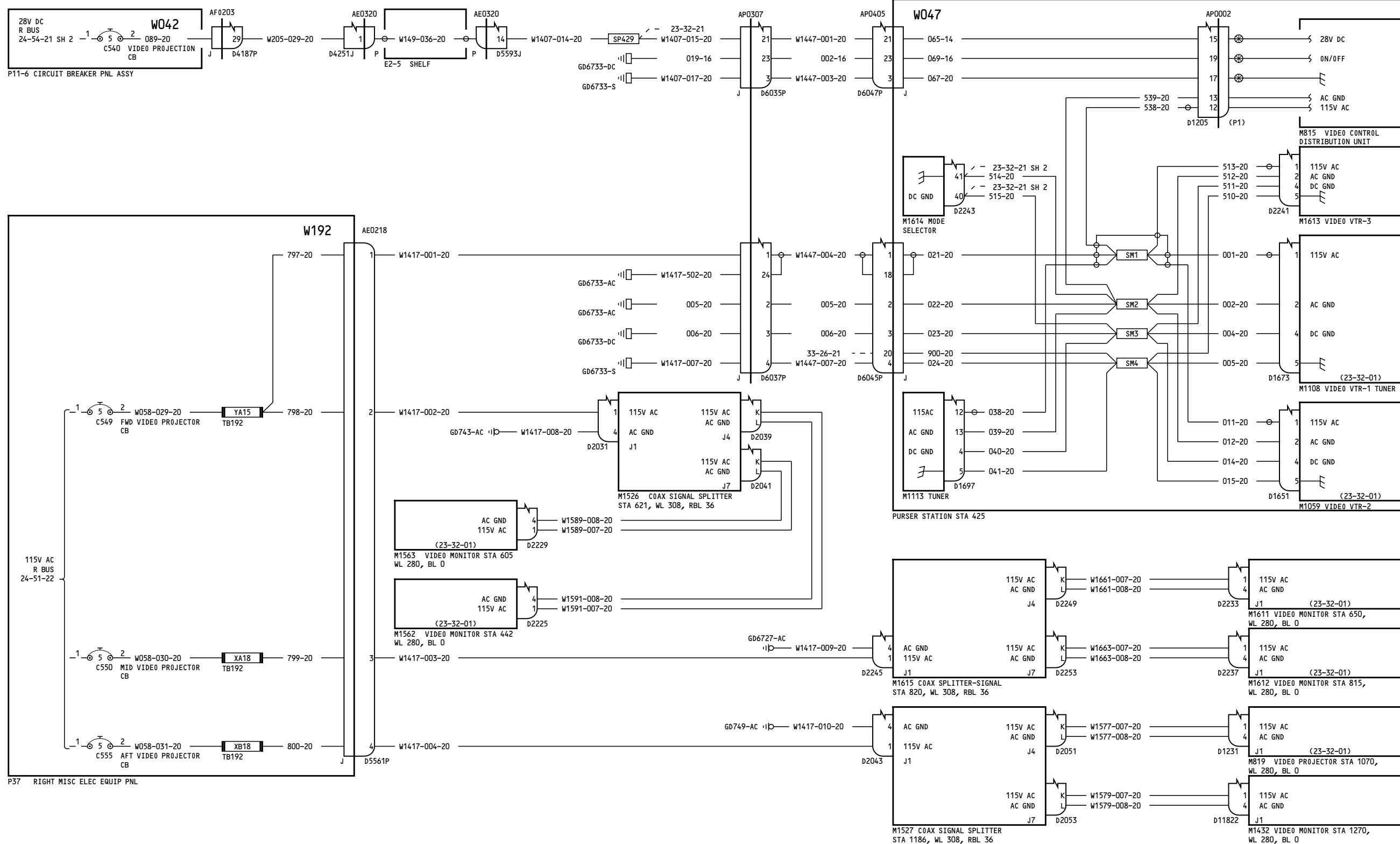

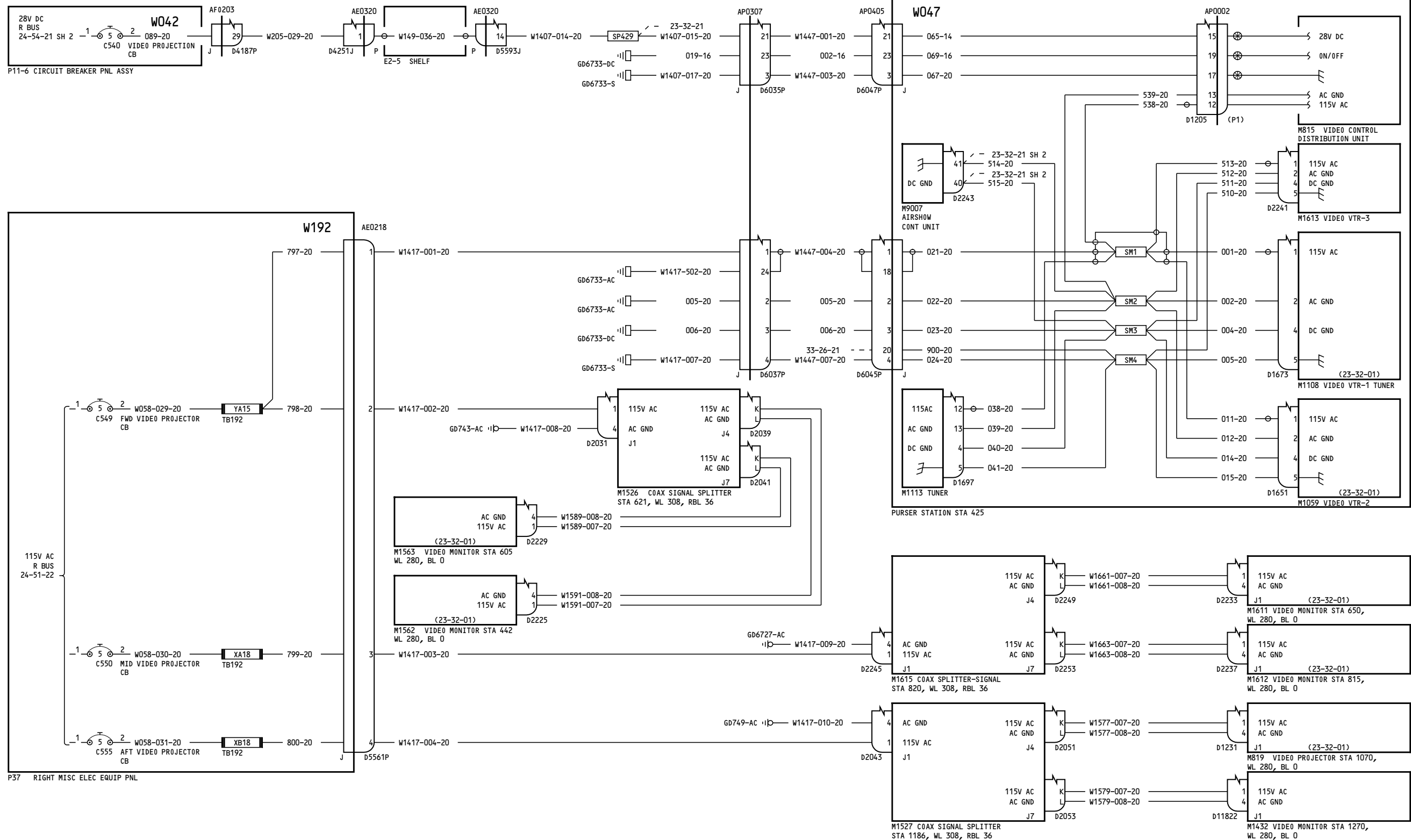

155

VIDEO PROJECTION-POWER

23-32-11

Page 5A

Jan 21/2005

D280T132

Incorporates

- MTO 230523
- MTO 230532
- MTO 330286 R01
- MTO-230718

23-32-11

Page 5A

Jan 21/2005

BOEING PROPRIETARY - Copyright © - Unpublished Work - See title page for details.

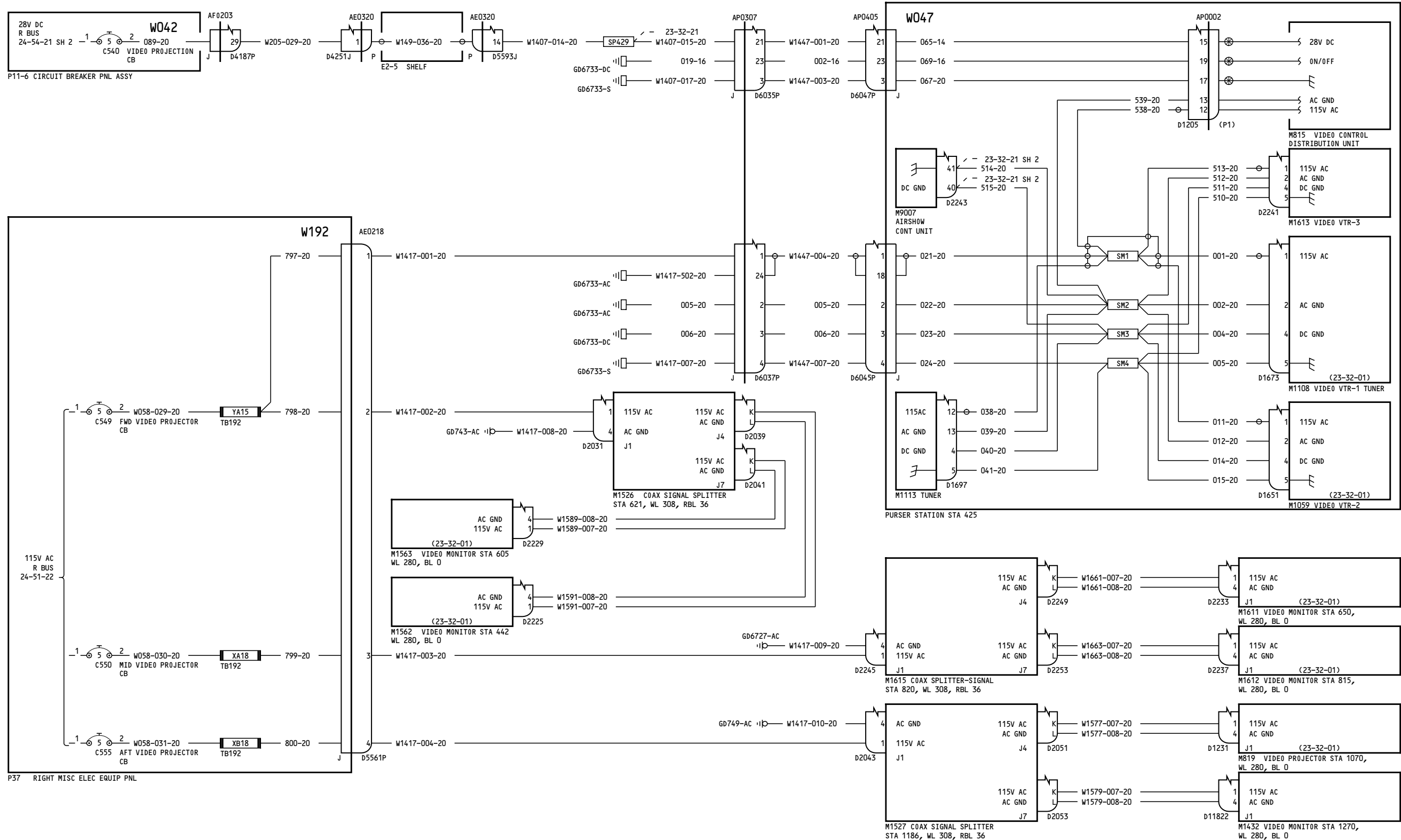

156-157, 166-167

VIDEO PROJECTION-POWER

23-32-11

Page 6A

D280T132

Jan 21/2005

- Incorporates
- MTO 230523
 - MTO 230532
 - MTO-230718

23-32-11

Page 6A

Jan 21/2005

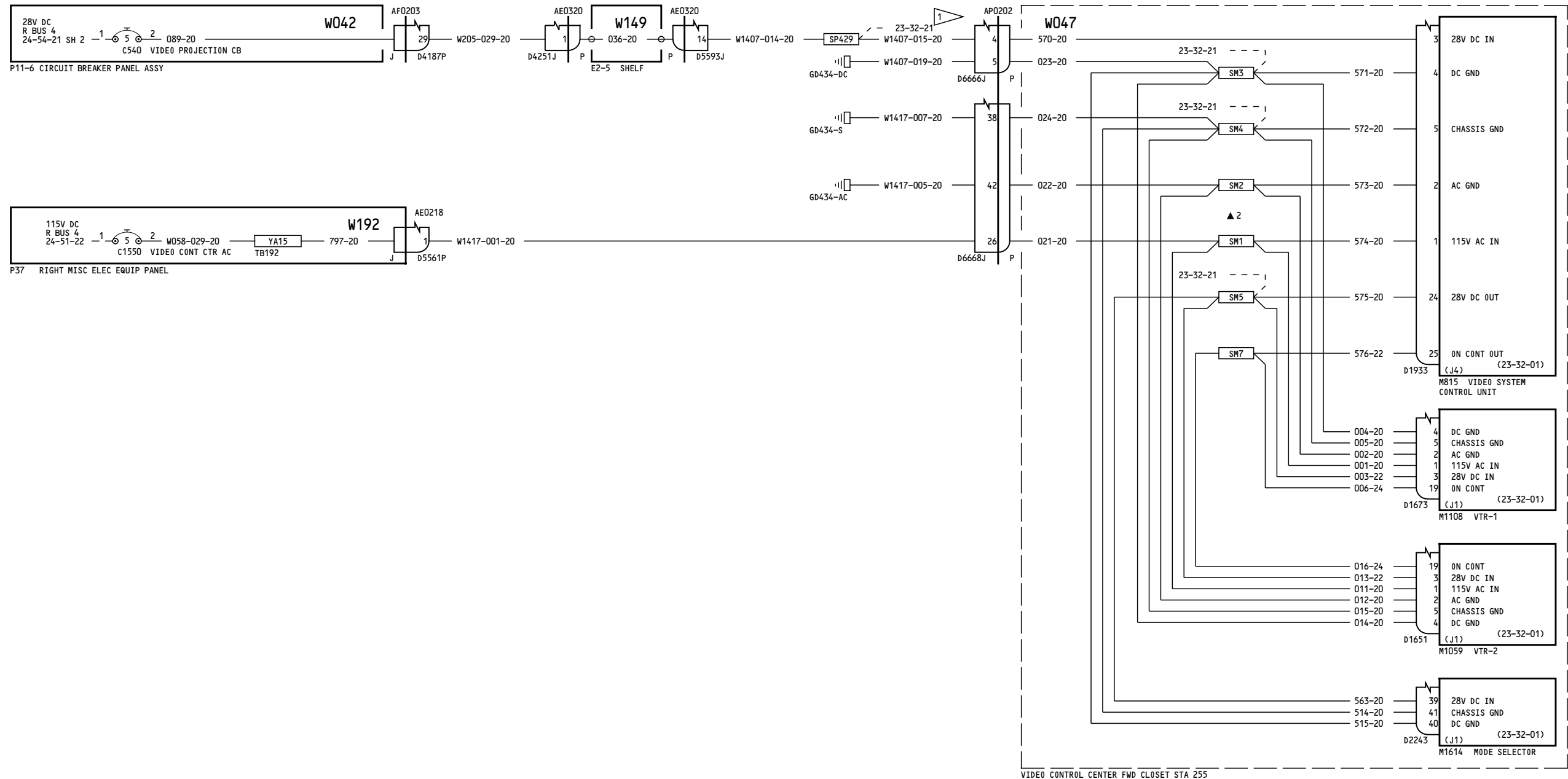

VIDEO CONTROL CENTER FWD CLOSET STA 255

NOTES:
1 APO205 FOR VN222-VN222 (276)

275-276

**VIDEO PROJECTION-
POWER**

23-32-11

Page 7

Jan 21/2005

D280T132

23-32-11

Page 7

Jan 21/2005

-A

52

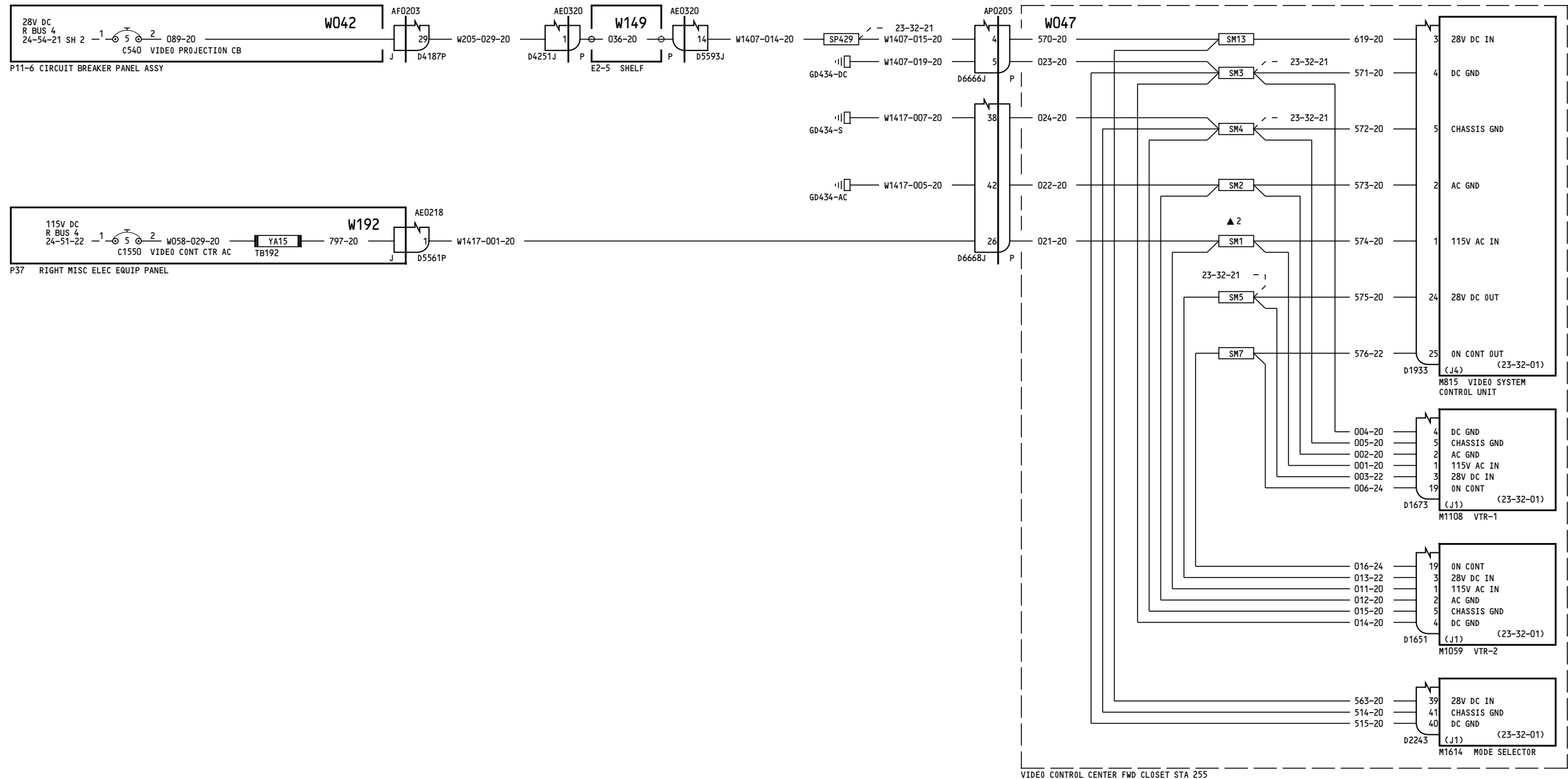

277-278	<p align="center">VIDEO PROJECTION- POWER</p> <p align="center">D280T132</p>
---------	-----------------------------------------------------------------------------------------

23-32-11

Page 8

Jan 21/2005

23-32-11

Page 8

Jan 21/2005

68

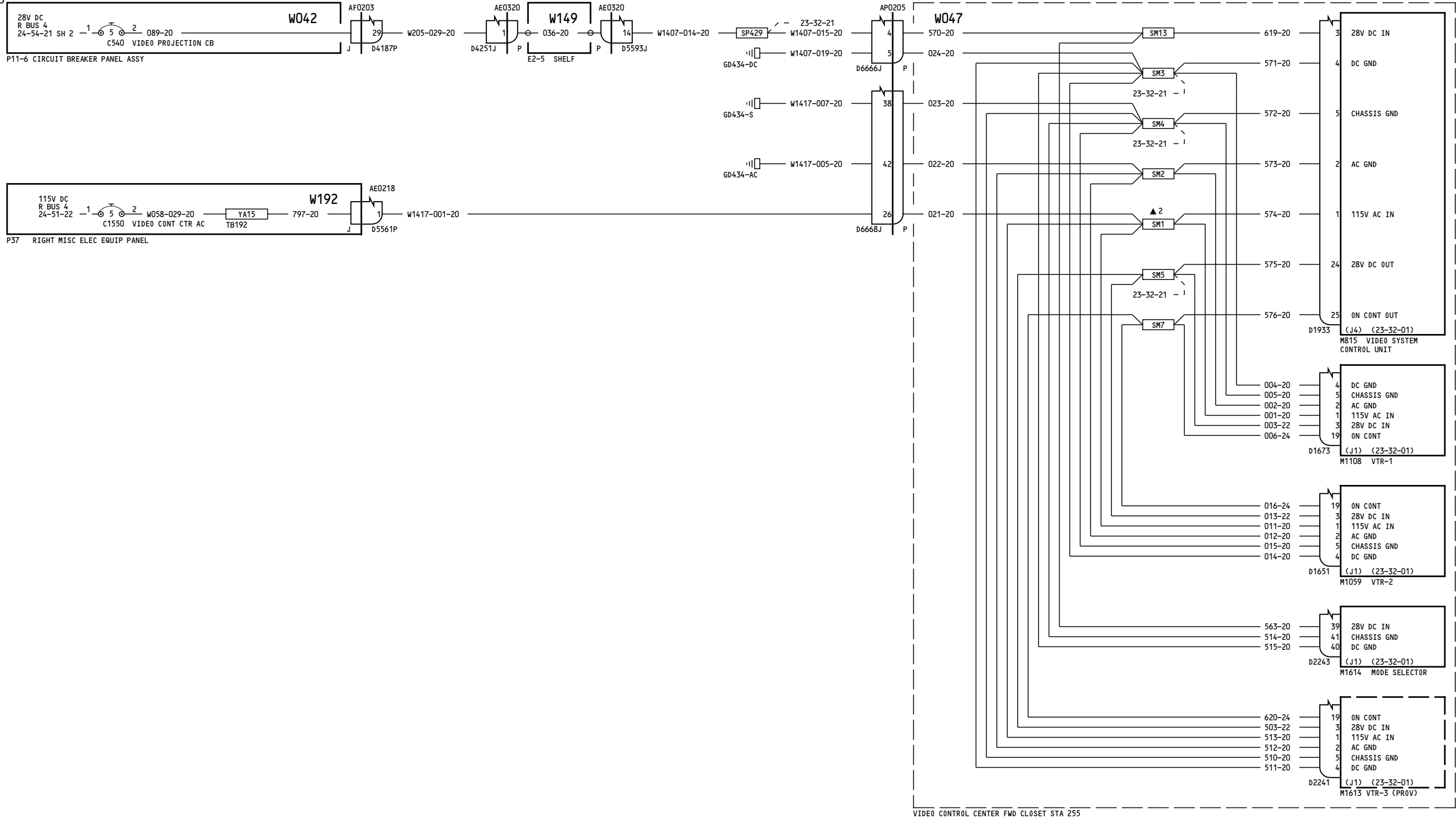

280-299	<p align="center">VIDEO PROJECTION-POWER</p> <p align="center">D280T132</p>
---------	------------------------------------------------------------------------------------

23-32-11

Page 9

Jan 21/2005

23-32-11

Page 9

Jan 21/2005

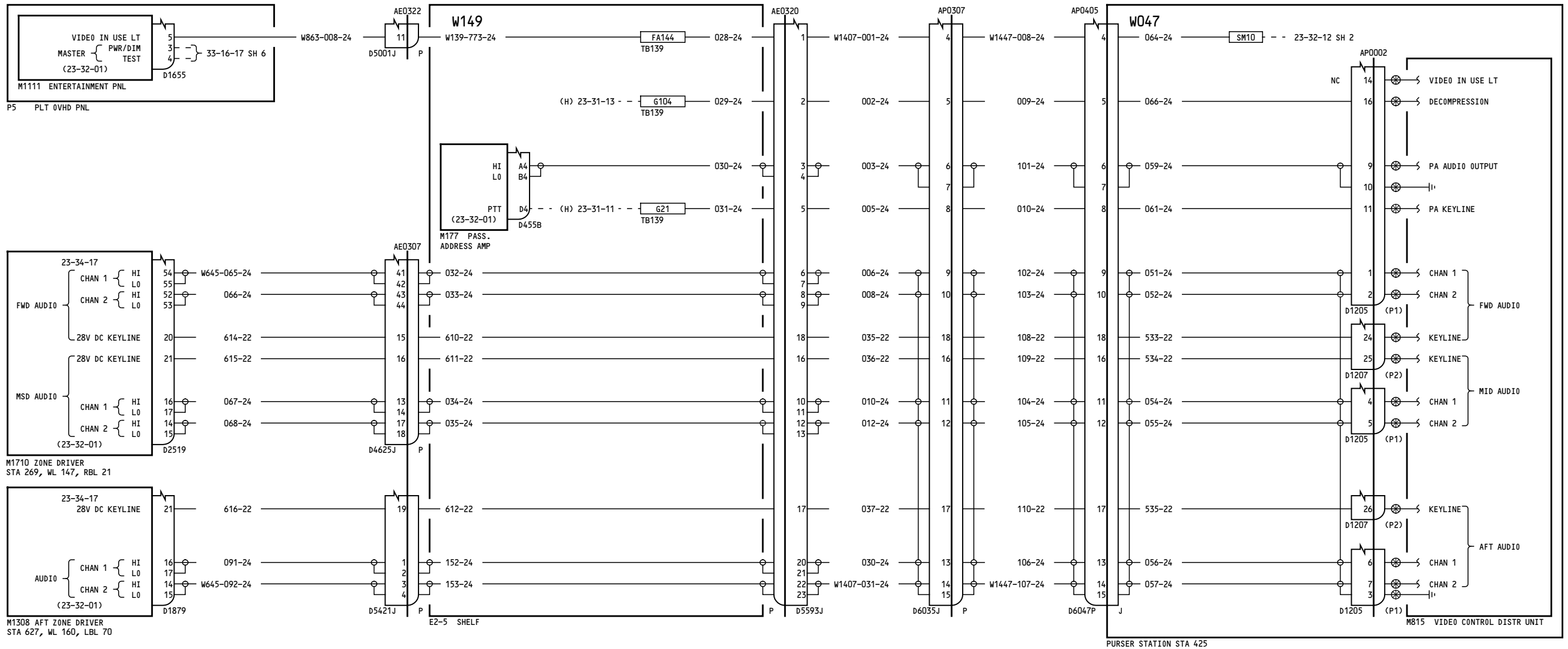

050-051	VIDEO PROJECTION-AUDIO
	D280T132

23-32-12

Page 1A
Sheet 1
Jan 21/2005

23-32-12

Page 1A
Sheet 1
Jan 21/2005

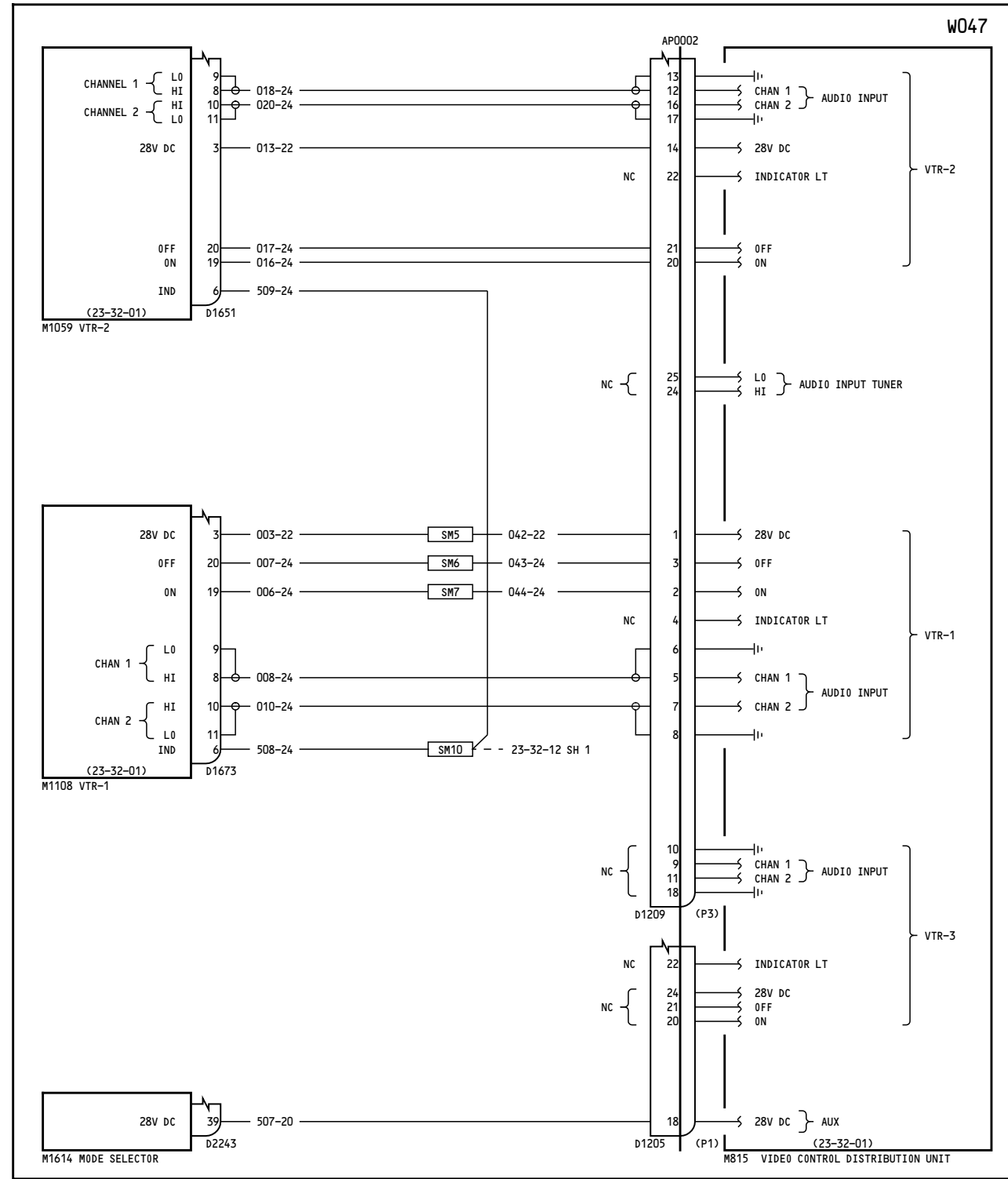

GALLEY G3

050-051

VIDEO PROJECTION-AUDIO

23-32-12

Page 1A
Sheet 2
Jan 21/2005

D280T132

Incorporates
MTO 230540

23-32-12

Page 1A
Sheet 2
Jan 21/2005

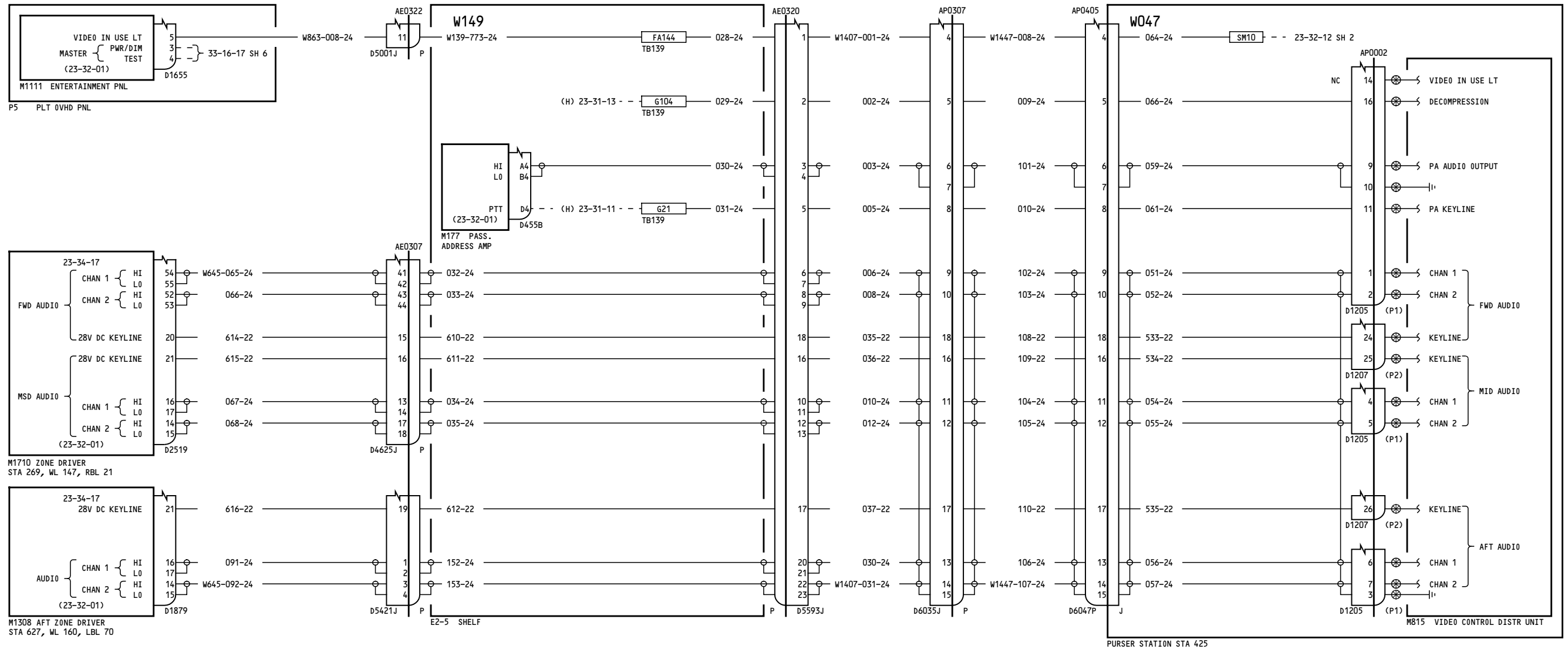

150, 153-154

VIDEO PROJECTION-AUDIO

23-32-12

Page 2A
Sheet 1
Jan 21/2005

D280T132

Incorporates
MTO 230441

23-32-12

Page 2A
Sheet 1
Jan 21/2005

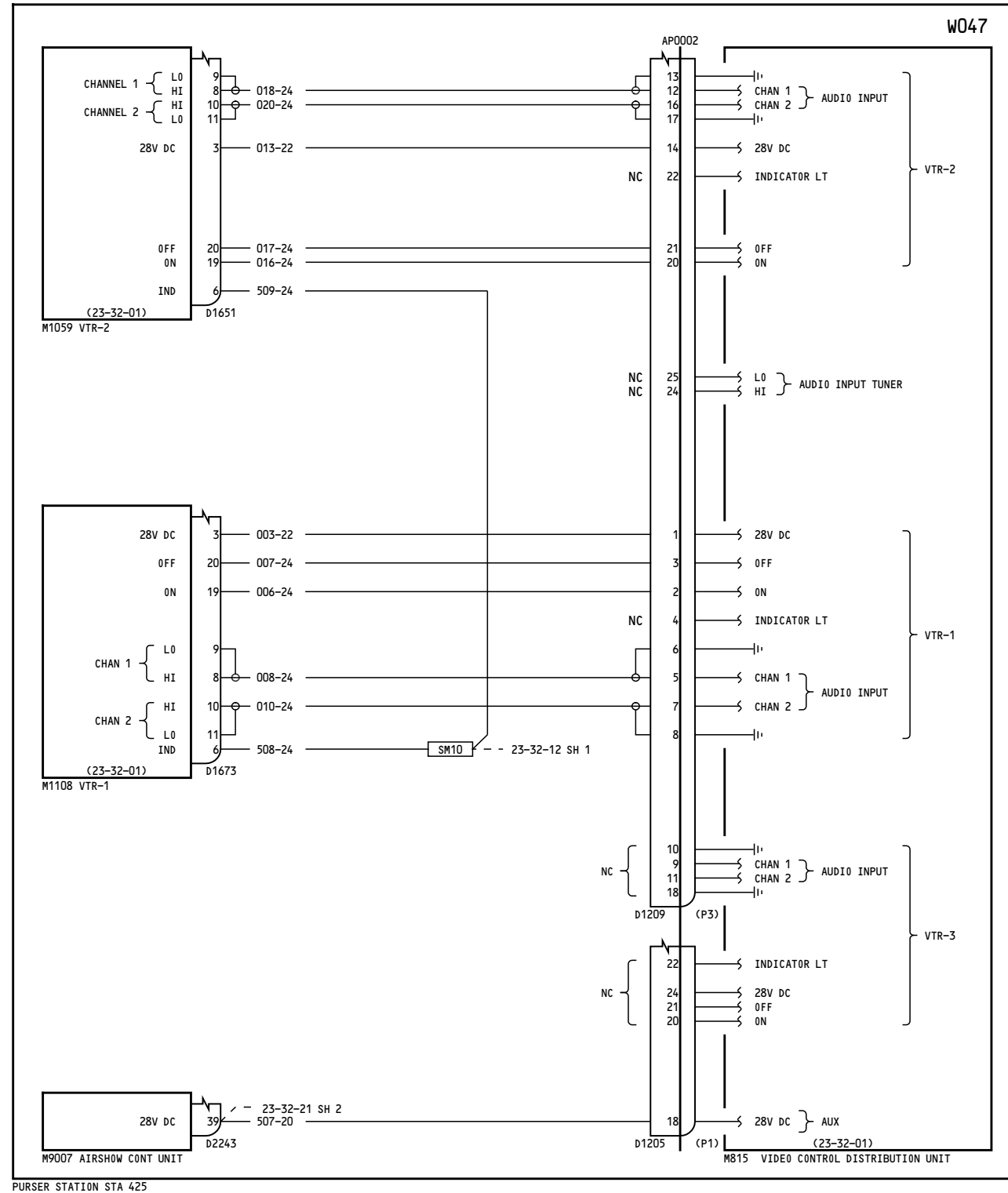

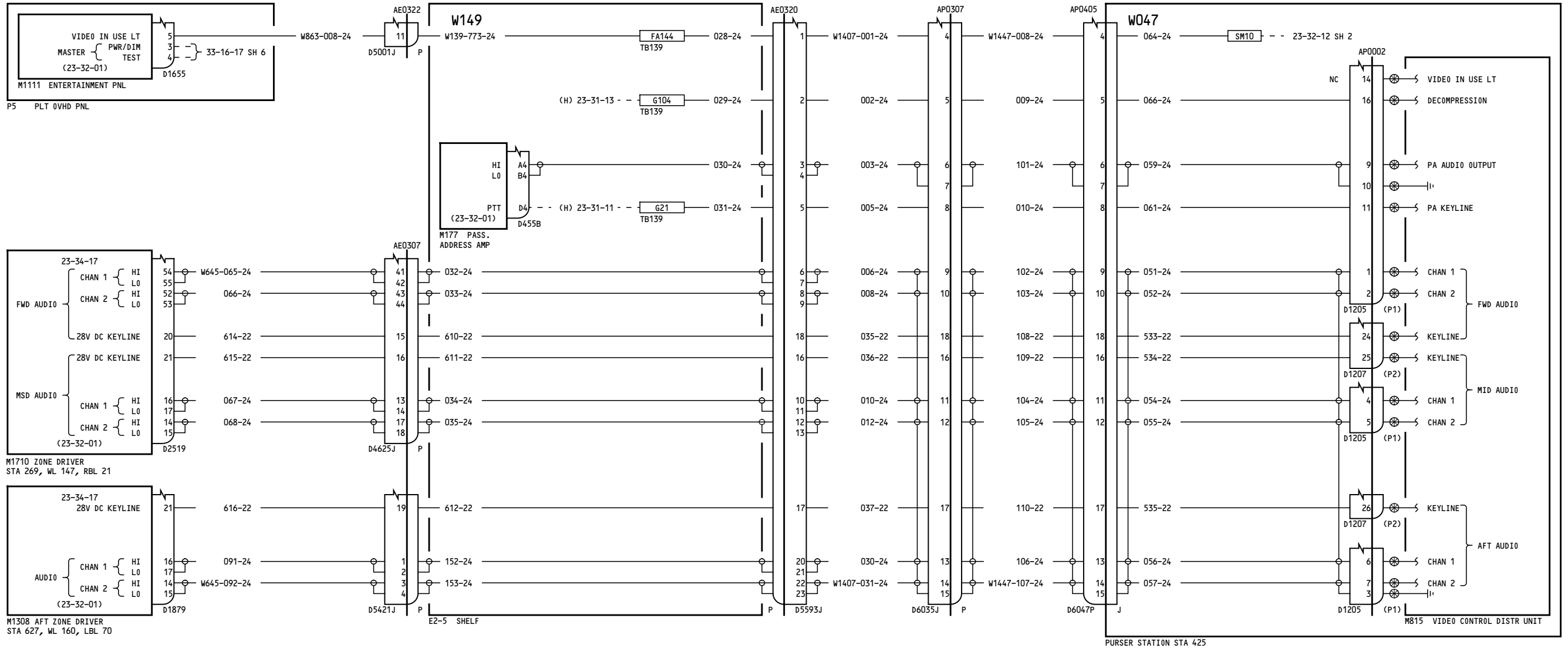

151

VIDEO PROJECTION-AUDIO

D280T132

23-32-12

Page 3A
Sheet 1
Jan 21/2005

Incorporates
MTO 230441

23-32-12

Page 3A
Sheet 1
Jan 21/2005

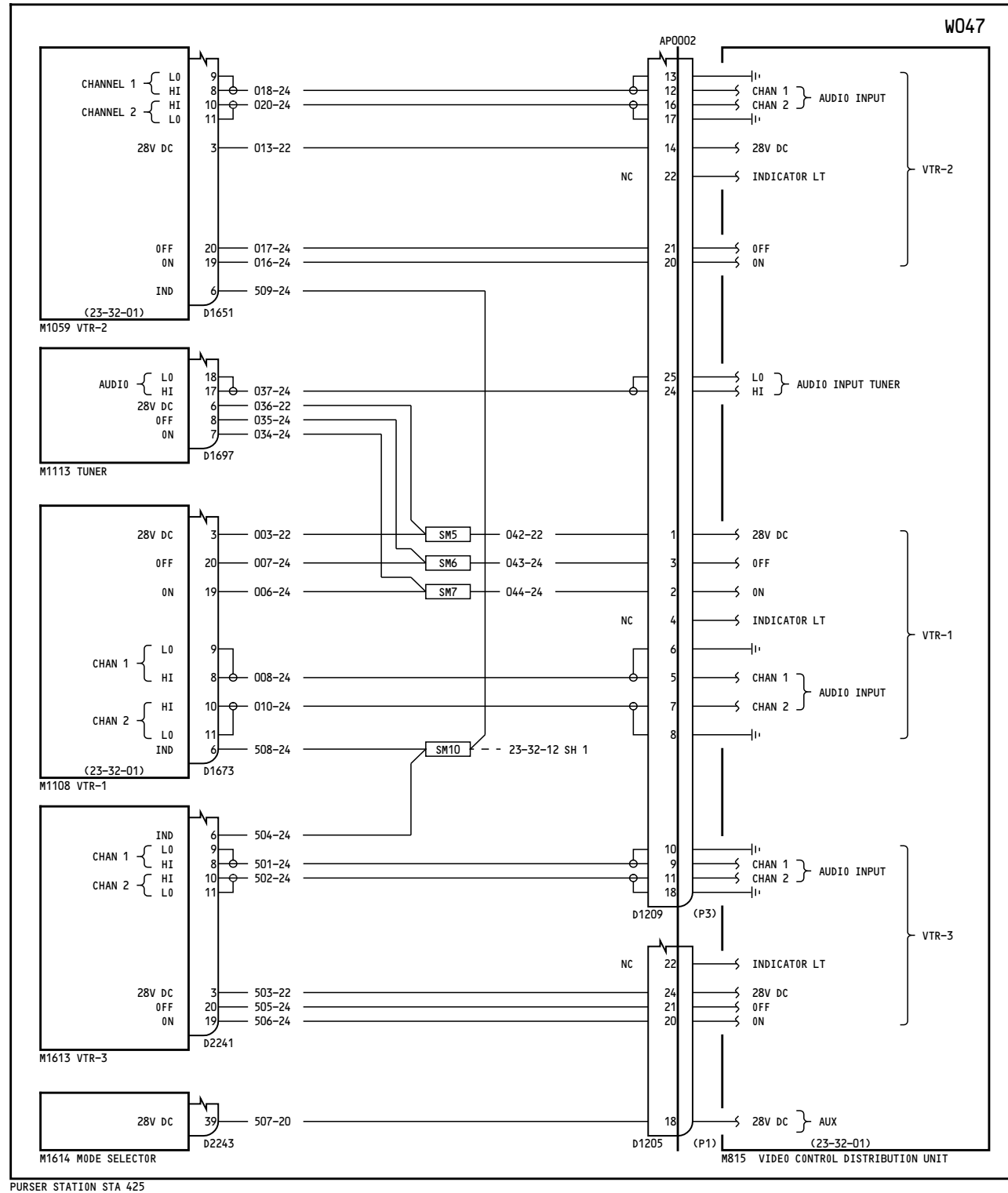

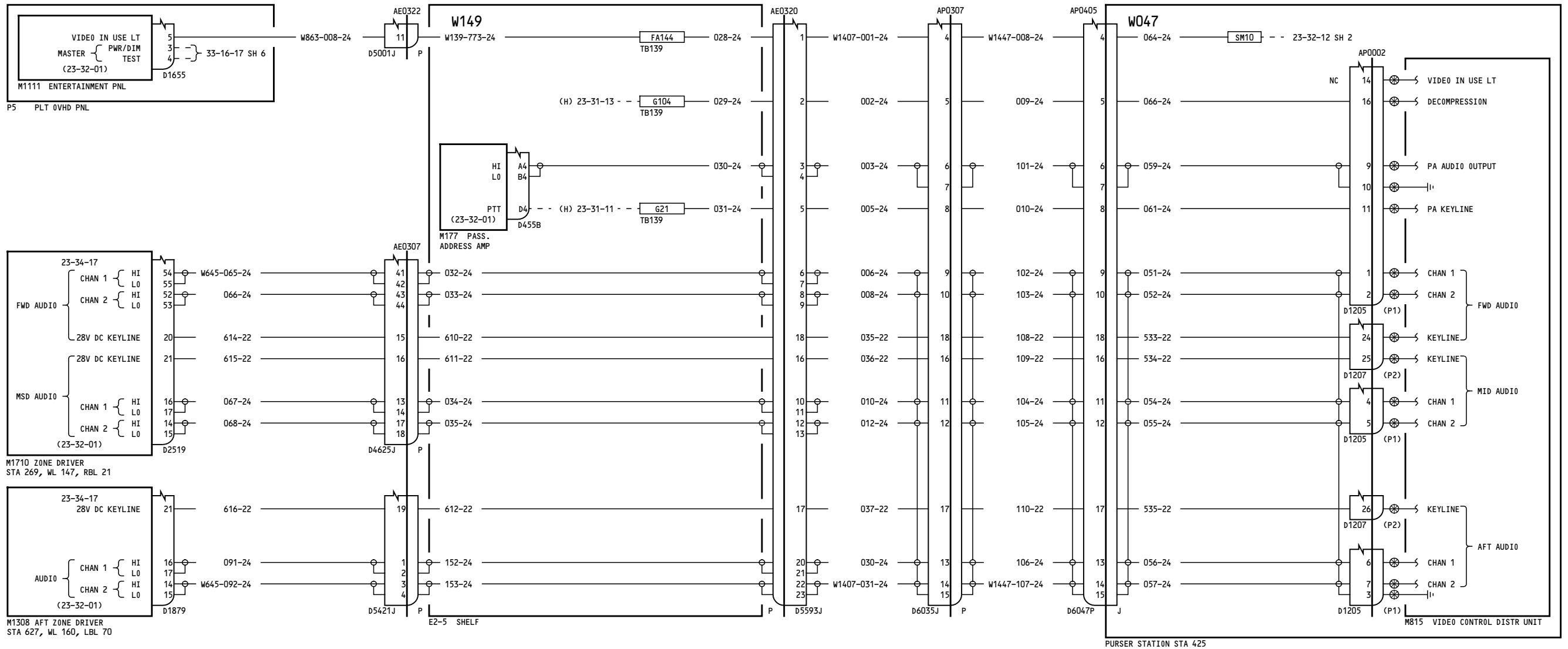

152	<p>VIDEO PROJECTION-AUDIO</p> <p>D280T132</p>
-----	-------------------------------------------------------------

23-32-12

Page 4A
Sheet 1
Jan 21/2005

Incorporates
MTO 230441

23-32-12

Page 4A
Sheet 1
Jan 21/2005

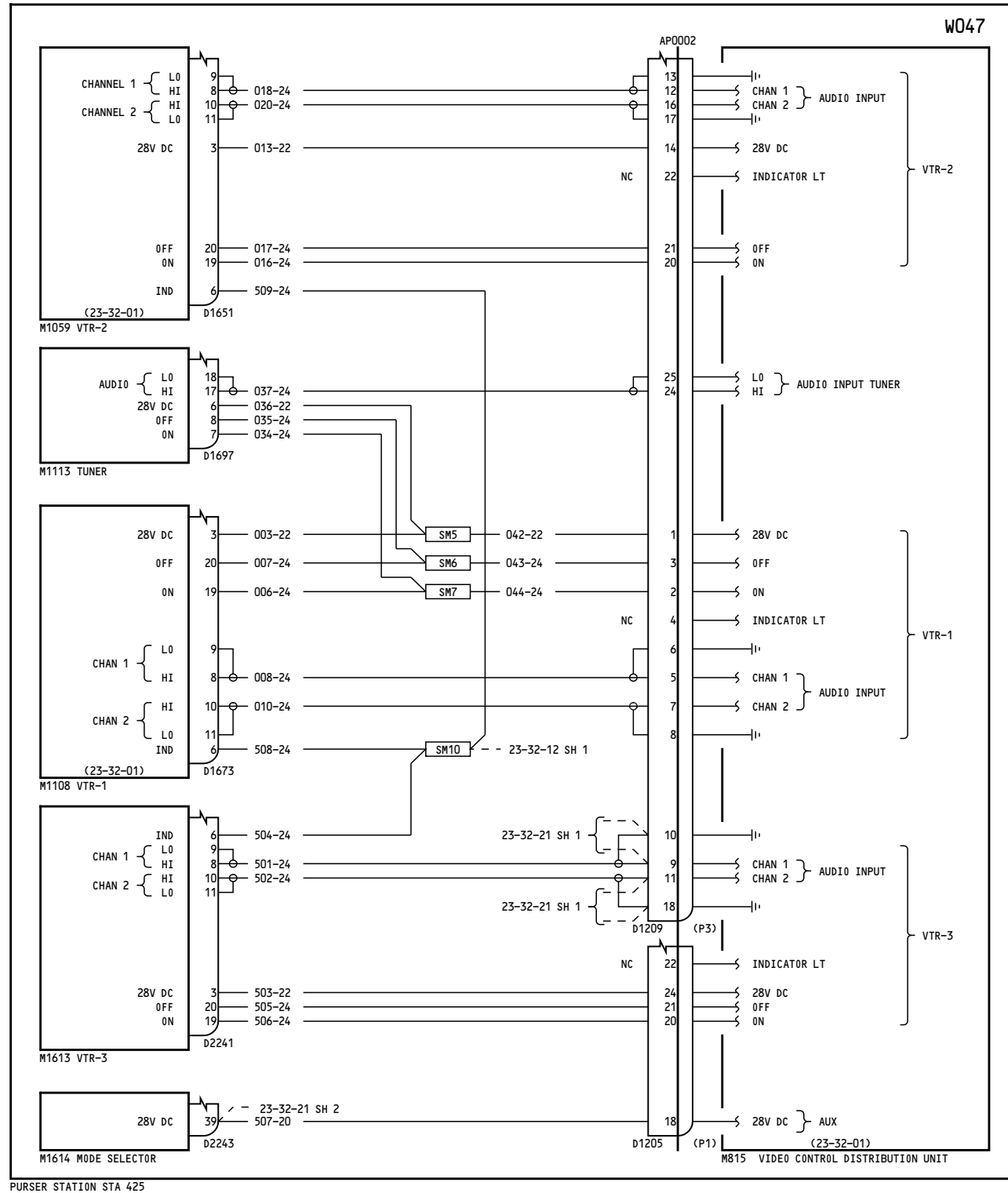

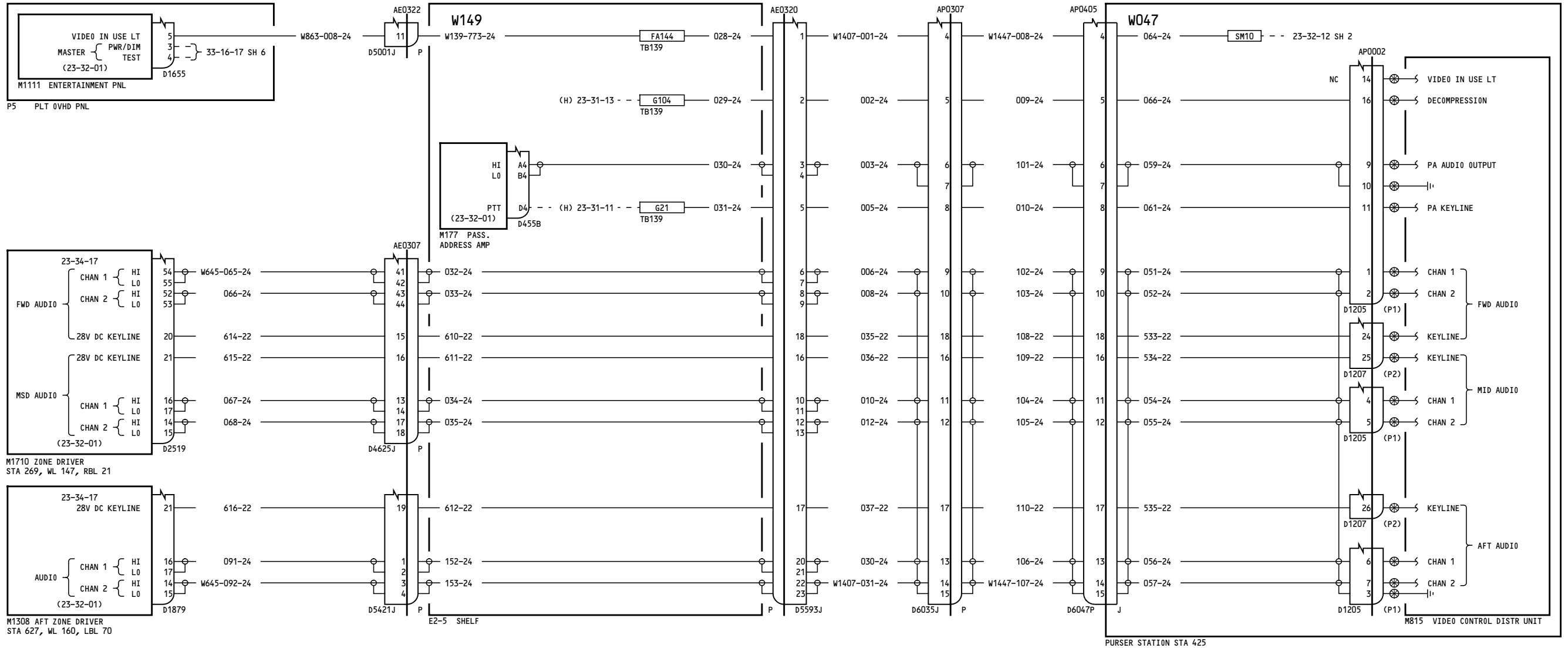

155-167	VIDEO PROJECTION-AUDIO
	D280T132

23-32-12

Page 5A
Sheet 1
Jan 21/2005

23-32-12

Page 5A
Sheet 1
Jan 21/2005

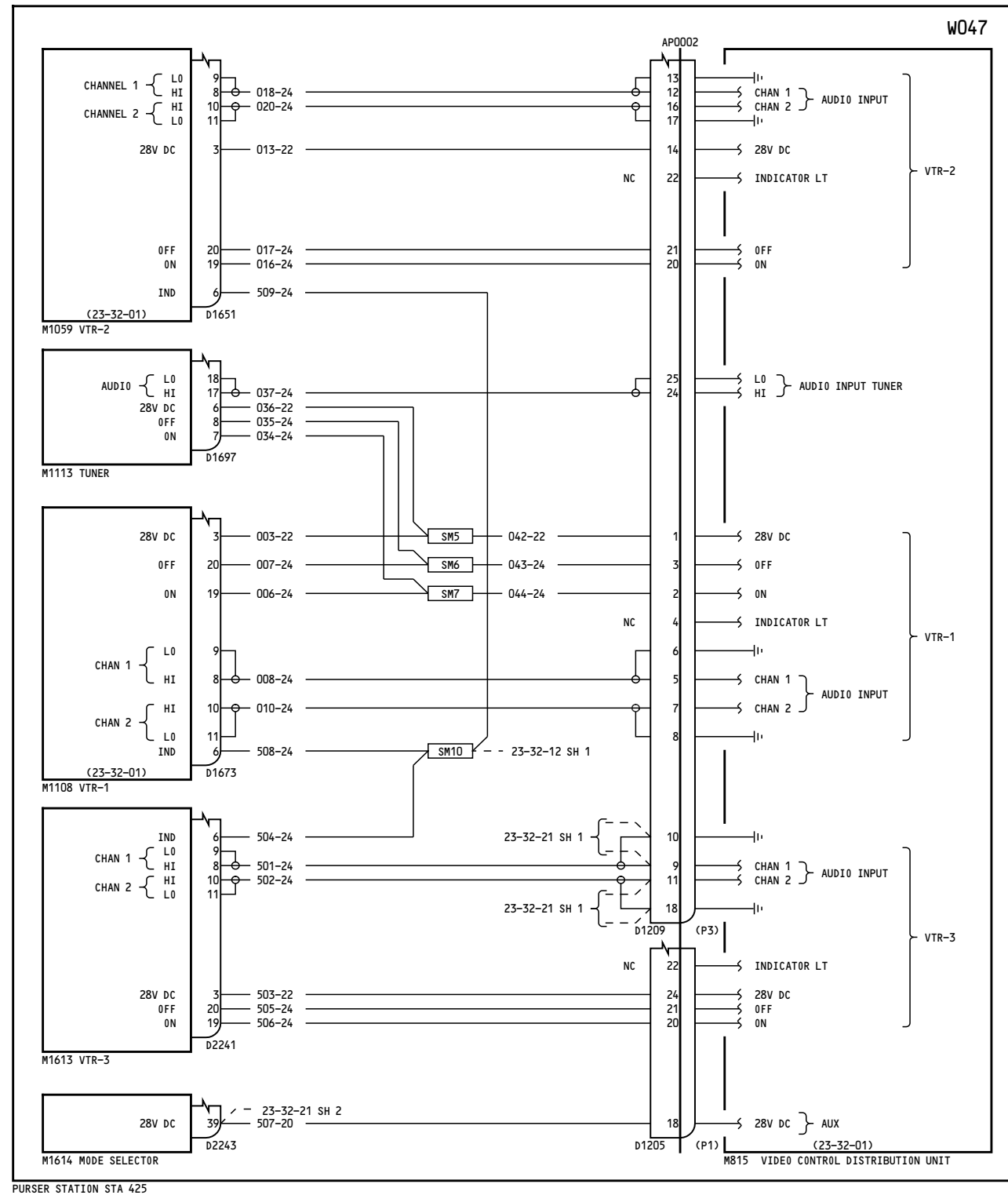

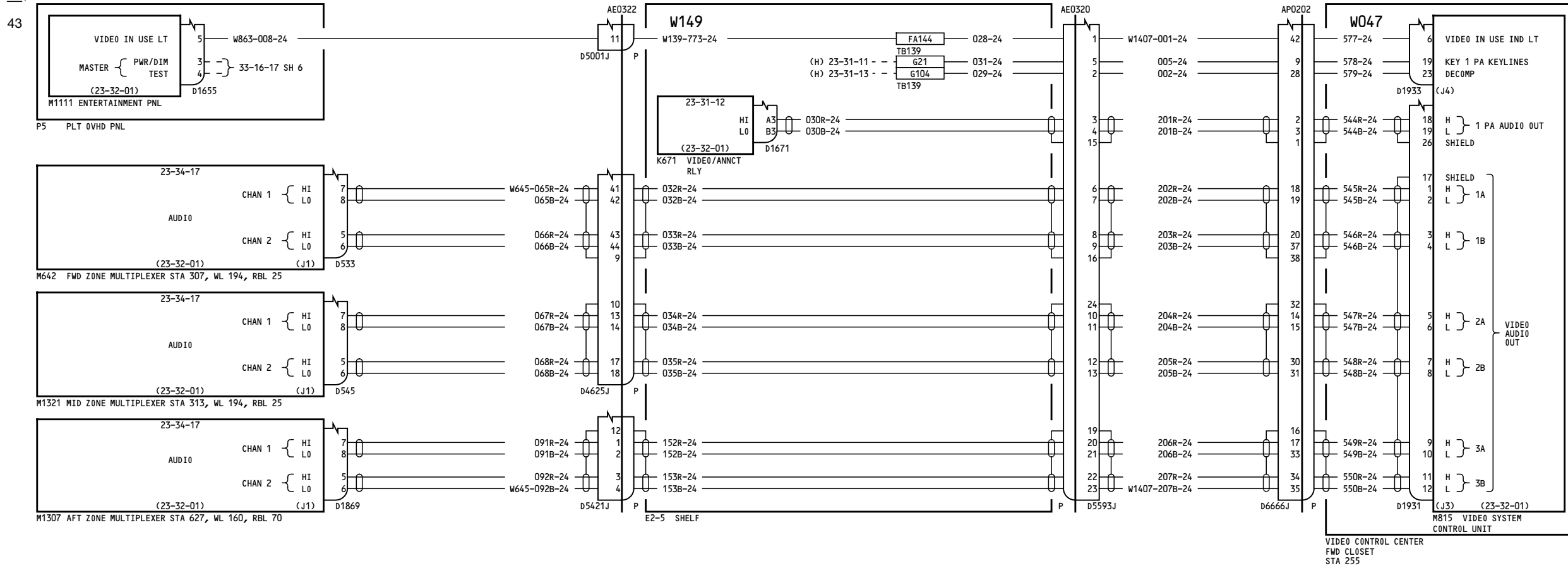

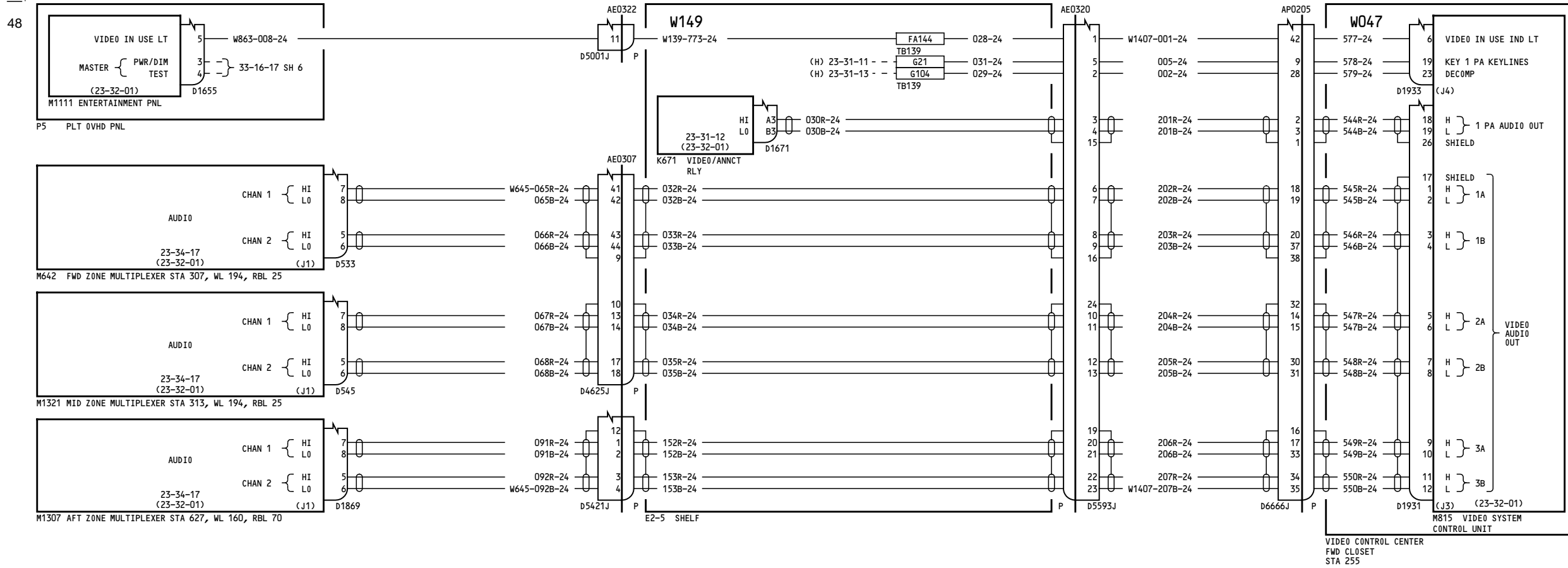

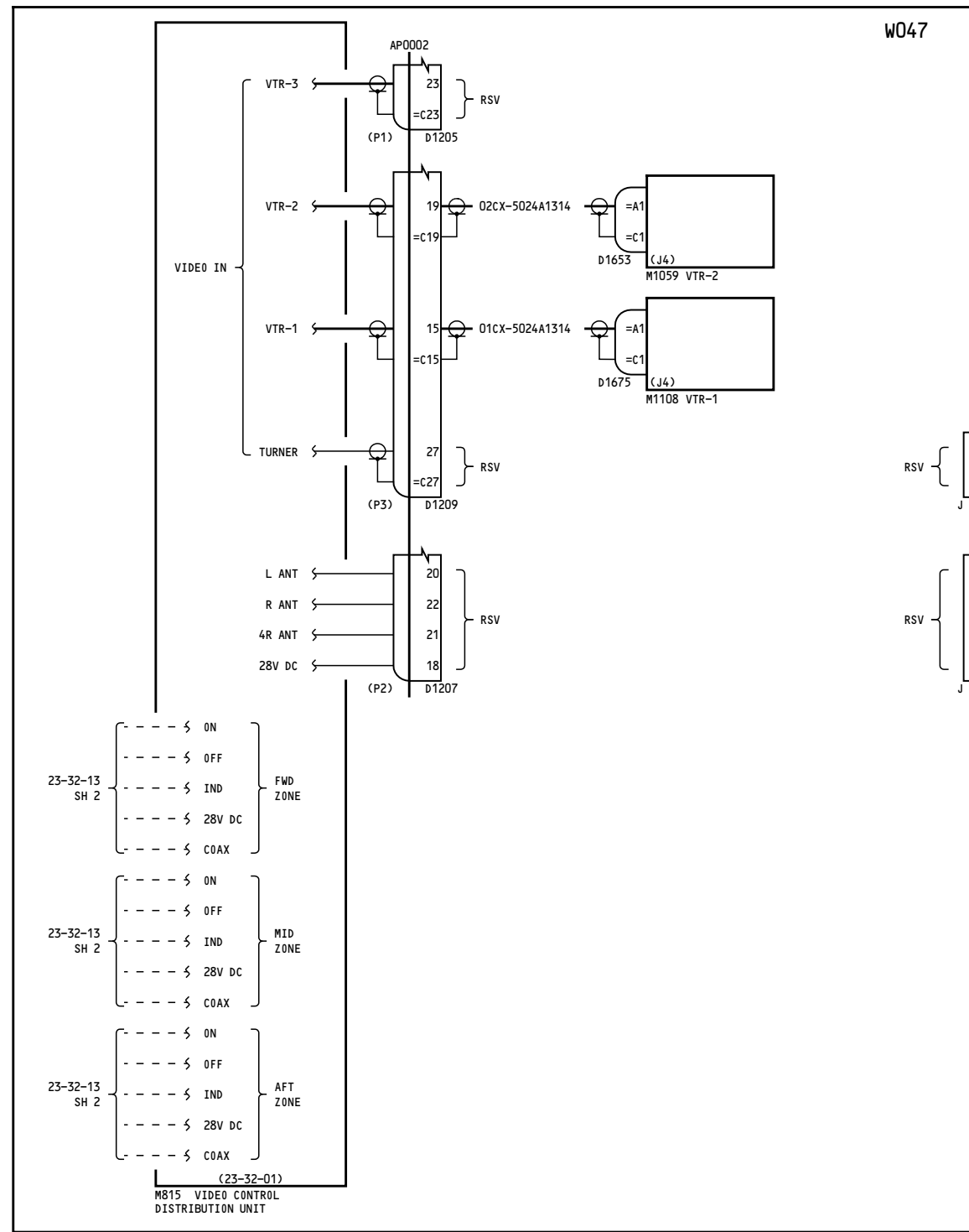

VIDEO CONTROL CENTER

- NOTES:
- 1 CRITICAL LENGTH IS 4 3.5" ± 1/2". A MAXIMUM OF 1" LENGTH DIFFERENCE IS ALLOWED BETWEEN W1427 AND W1431
 - 2 CRITICAL LENGTH IS 10 ± 1/2". A MAXIMUM OF 1" LENGTH DIFFERENCE IS ALLOWED BETWEEN W1429 AND W1433

050-051

VIDEO PROJECTION-DISTRIBUTION

D280T132

23-32-13

Page 1A
Sheet 1
Jan 21/2005

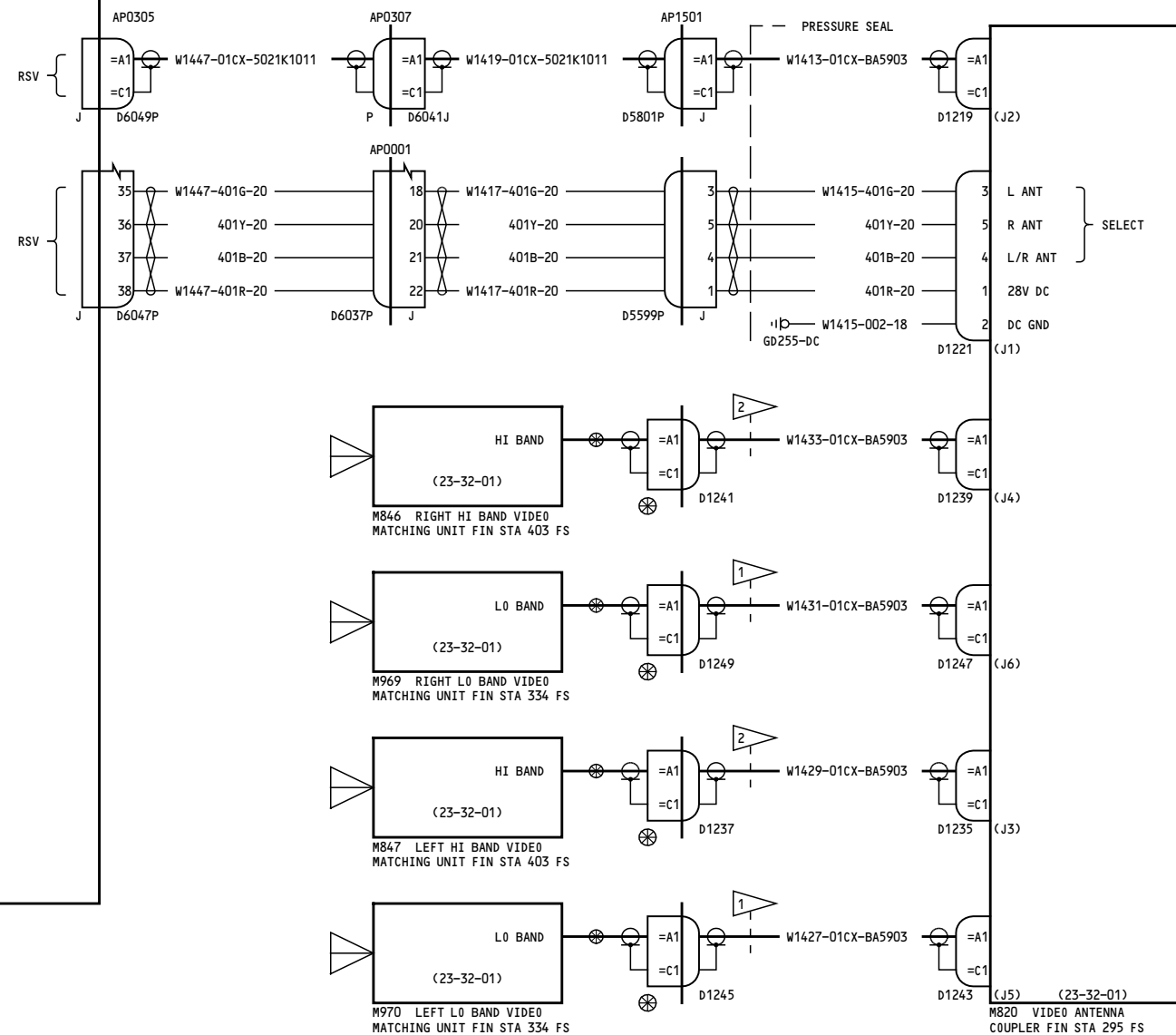

Incorporates
MTO 230540

23-32-13

Page 1A
Sheet 1
Jan 21/2005

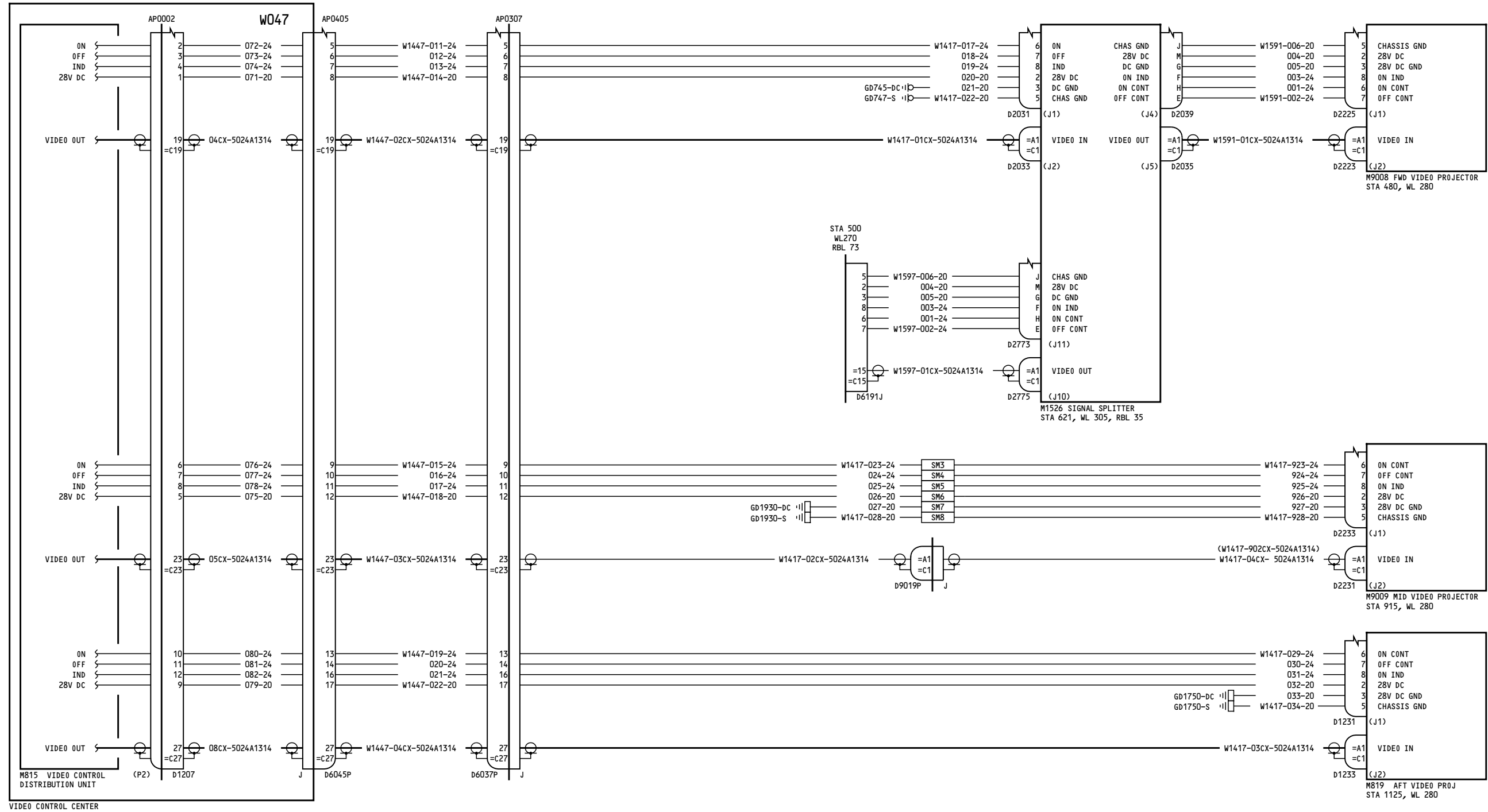

050-051

VIDEO PROJECTION-DISTRIBUTION

23-32-13

Incorporates MTO 230540

23-32-13

D280T132

Page 1A
Sheet 2
Jan 21/2005

Page 1A
Sheet 2
Jan 21/2005

175

W047

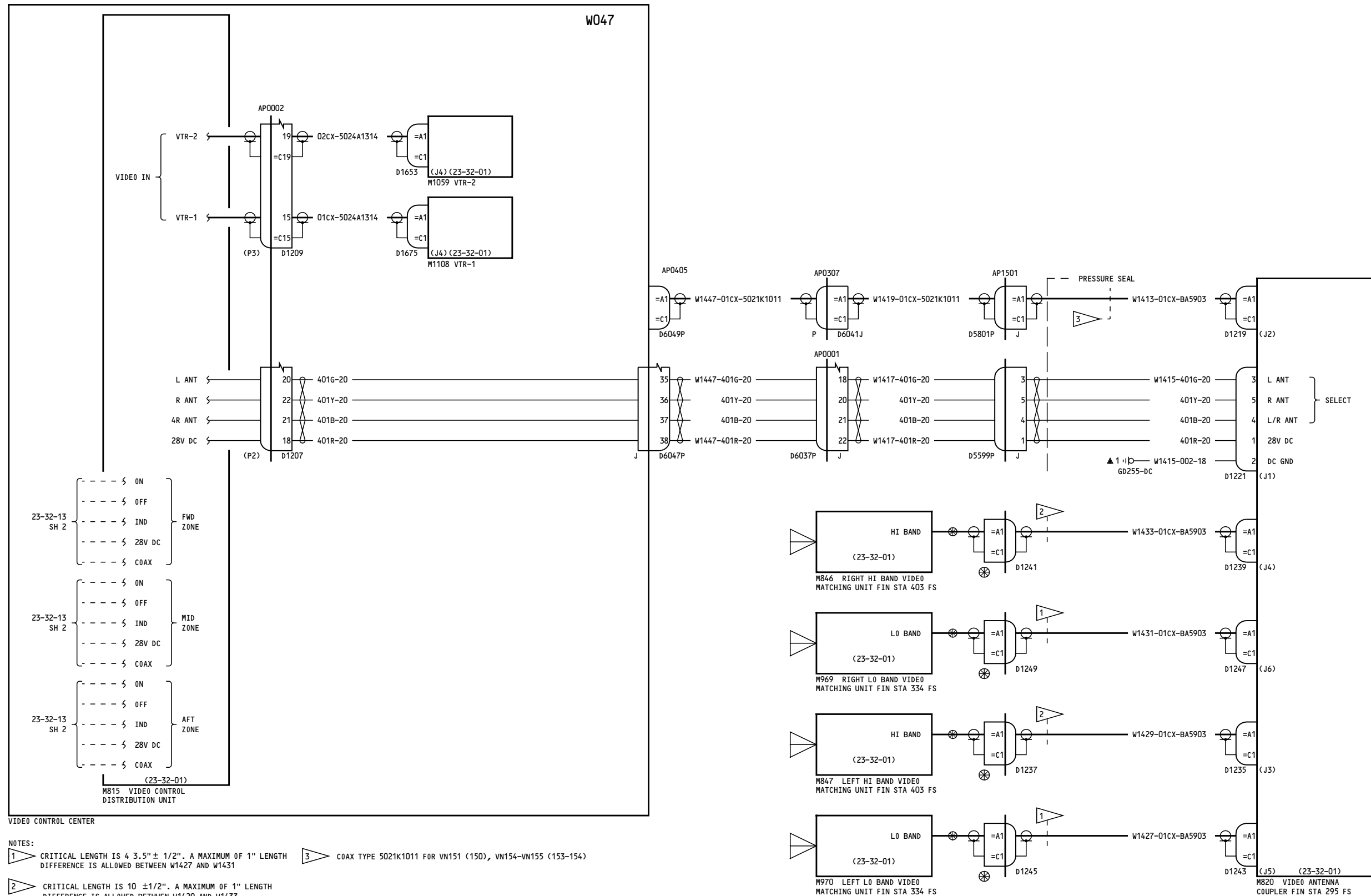

VIDEO CONTROL CENTER

- NOTES:
- 1 CRITICAL LENGTH IS 4 3.5" ± 1/2". A MAXIMUM OF 1" LENGTH DIFFERENCE IS ALLOWED BETWEEN W1427 AND W1431
 - 2 CRITICAL LENGTH IS 10 ± 1/2". A MAXIMUM OF 1" LENGTH DIFFERENCE IS ALLOWED BETWEEN W1429 AND W1433
 - 3 COAX TYPE 5021K1011 FOR VN151 (150), VN154-VN155 (153-154)

150, 153-157

VIDEO PROJECTION-DISTRIBUTION

23-32-13

Page 2A
Sheet 1
Jan 21/2005

D280T132

- Incorporates
- ▶ MTO 230523
 - ▶ MTO 230532

23-32-13

Page 2A
Sheet 1
Jan 21/2005

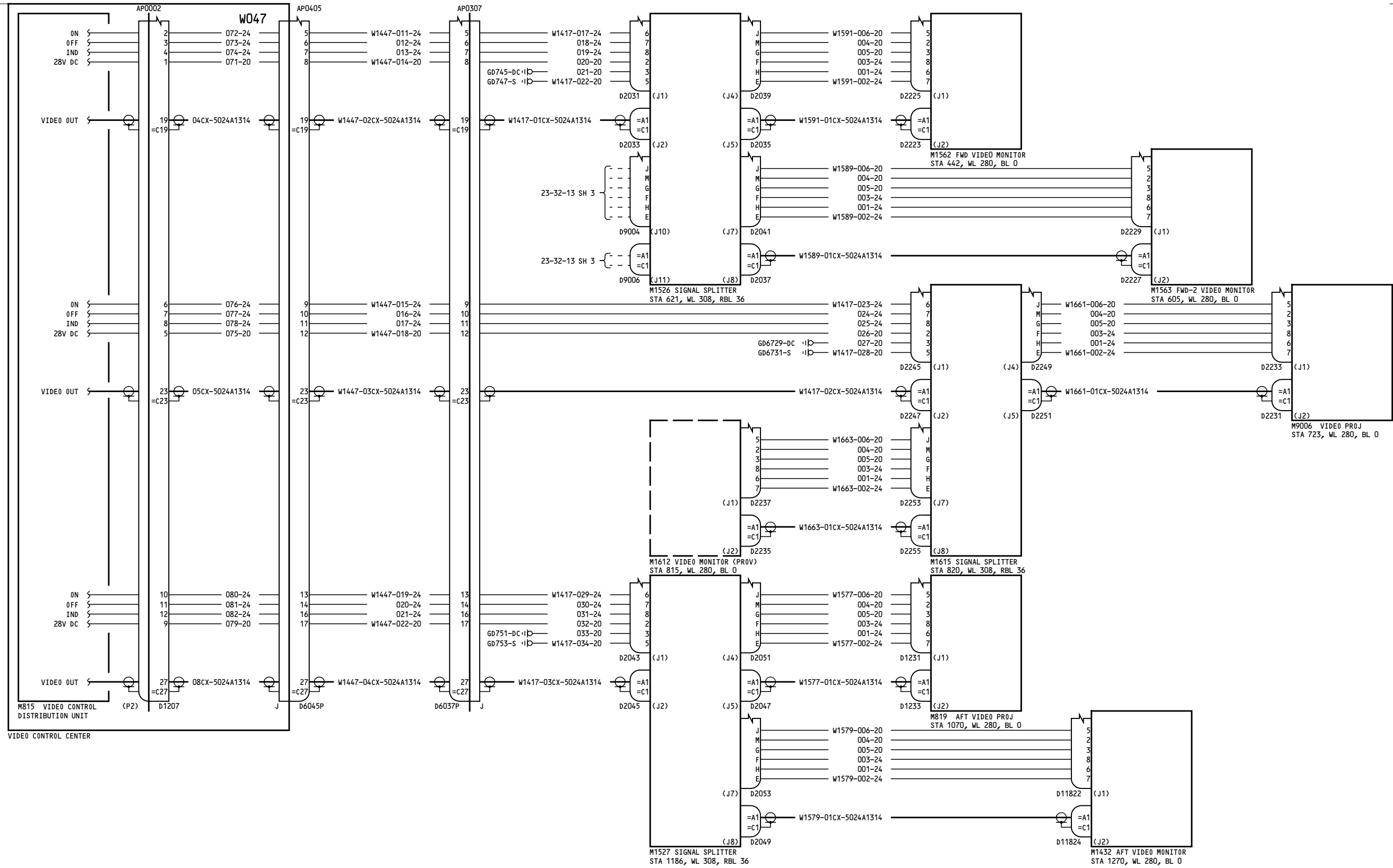

150, 153-157

VIDEO PROJECTION-DISTRIBUTION

D280T132

23-32-13

Page 2A
Sheet 2
Jan 21/2005

Incorporates
MTO 230523

23-32-13

Page 2A
Sheet 2
Jan 21/2005

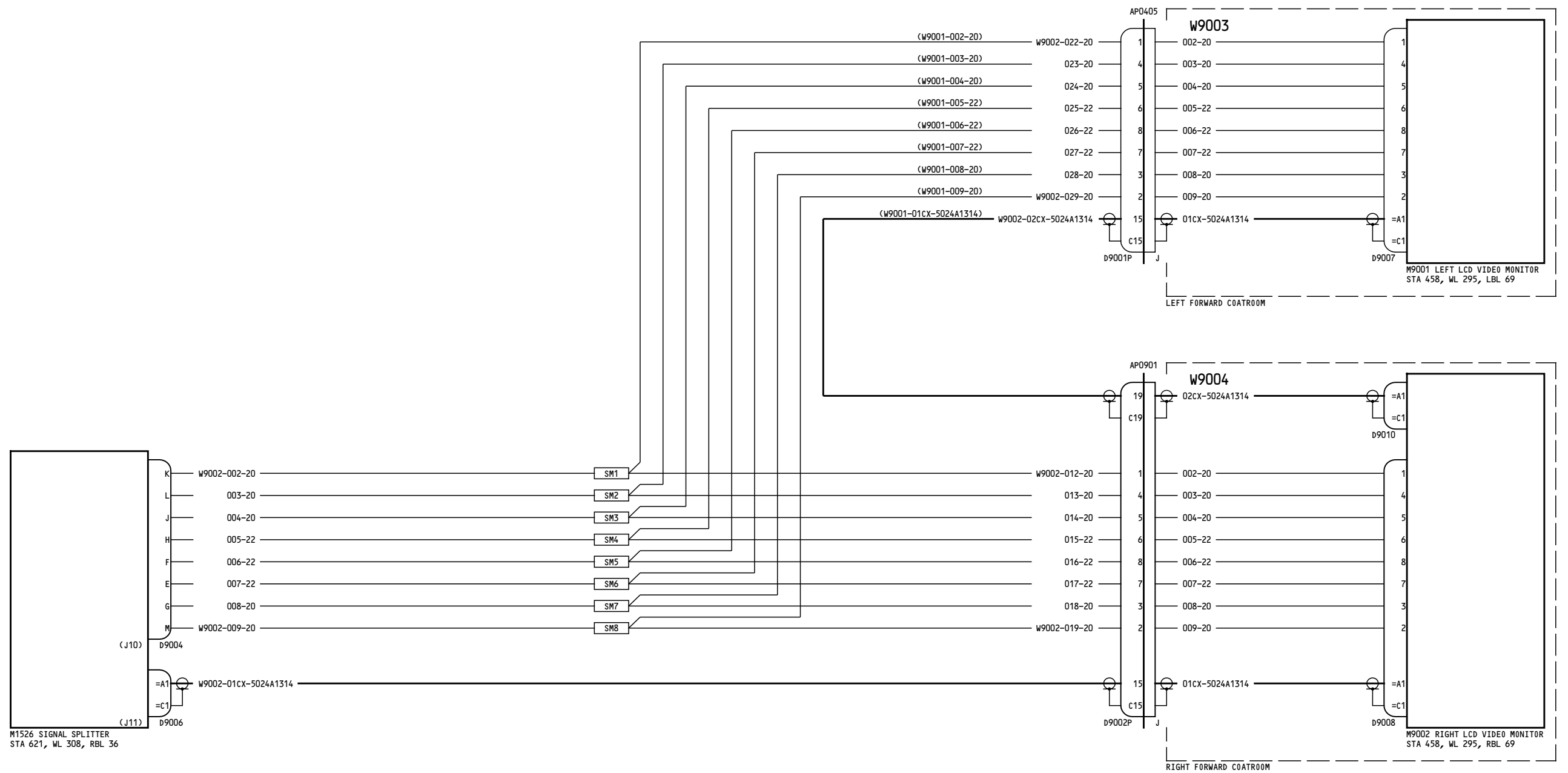

-A
36

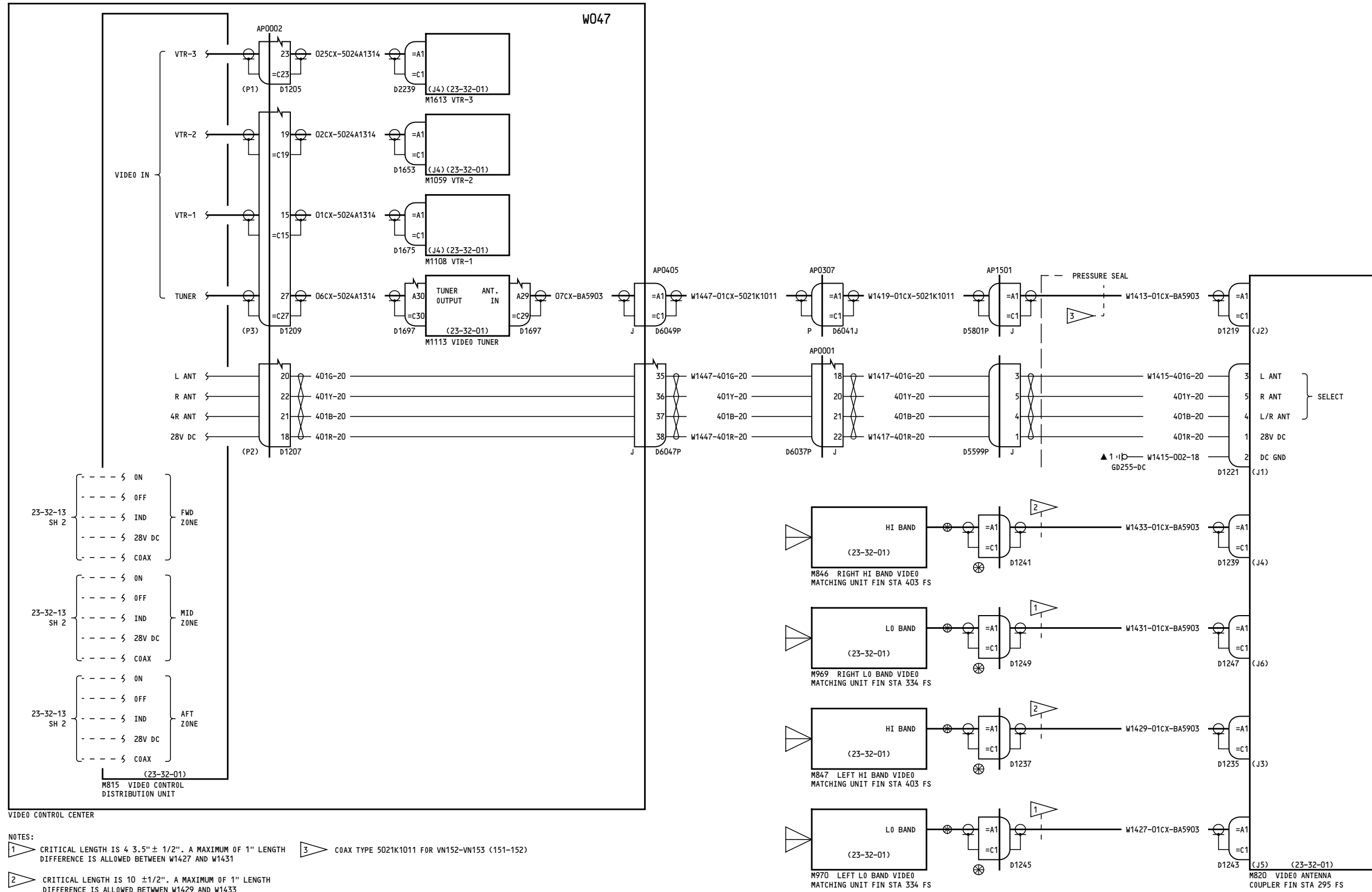

VIDEO CONTROL CENTER

- NOTES:
- 1 CRITICAL LENGTH IS 4 3.5" ± 1/2". A MAXIMUM OF 1" LENGTH DIFFERENCE IS ALLOWED BETWEEN W1427 AND W1431
 - 2 CRITICAL LENGTH IS 10 ± 1/2". A MAXIMUM OF 1" LENGTH DIFFERENCE IS ALLOWED BETWEEN W1429 AND W1433
 - 3 COAX TYPE 5021K1011 FOR VN152-VN153 (151-152)

151

VIDEO PROJECTION-DISTRIBUTION

23-32-13

Page 3
Sheet 1
Jan 21/2005

D280T132

23-32-13

Page 3
Sheet 1
Jan 21/2005

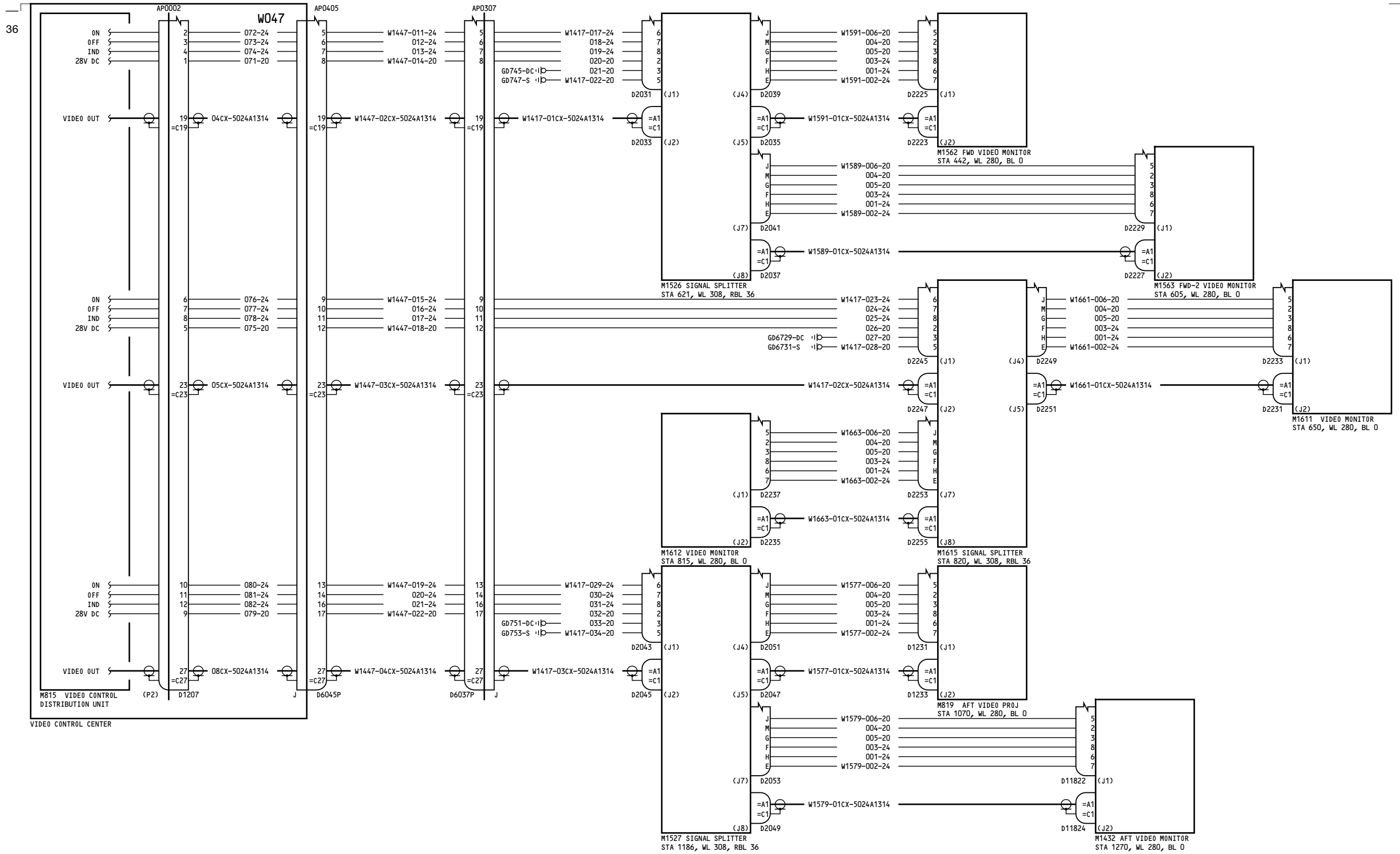

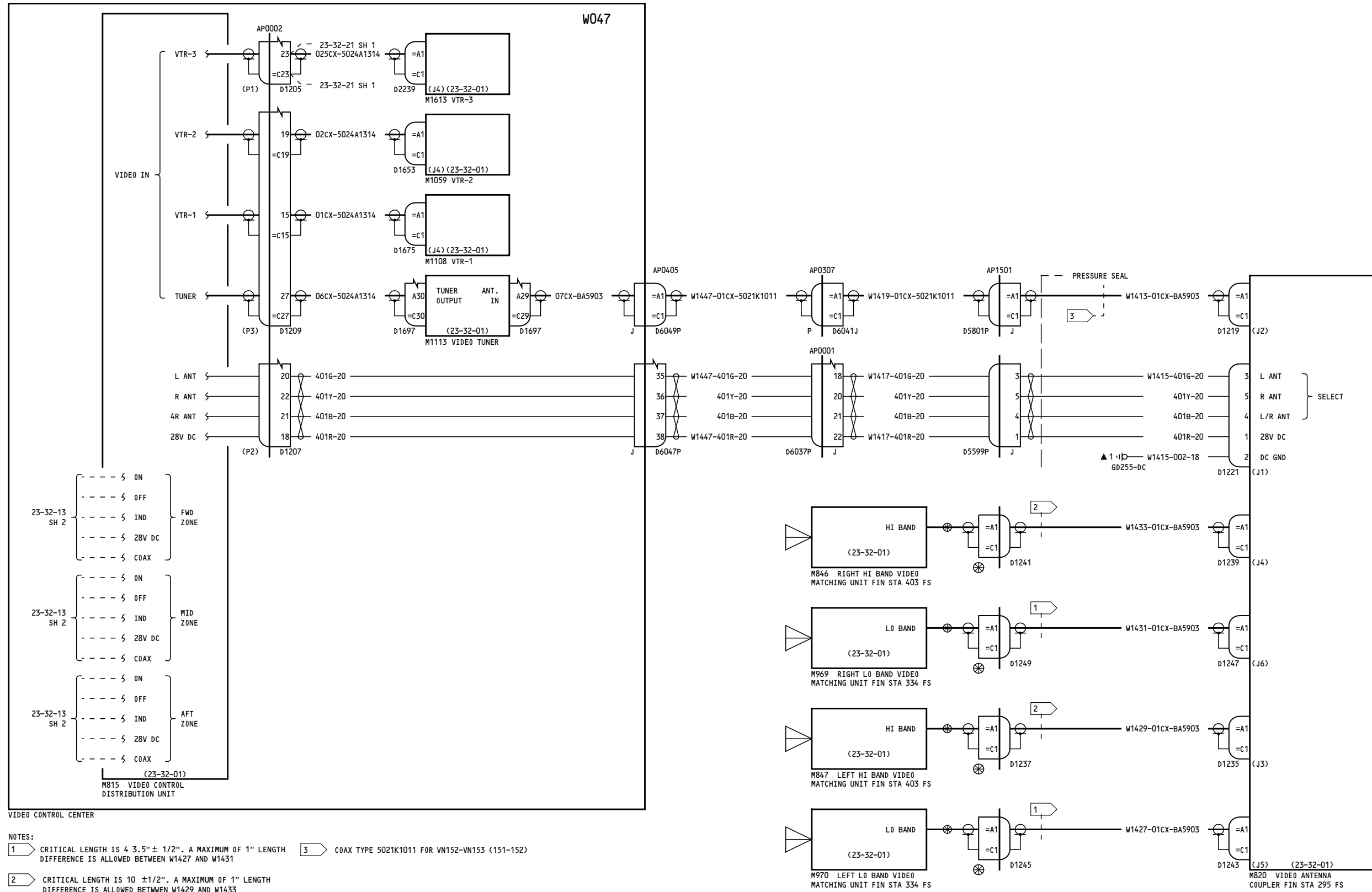

VIDEO PROJECTION-DISTRIBUTION

23-32-13

D280T132

Incorporates
MTO-230718

23-32-13

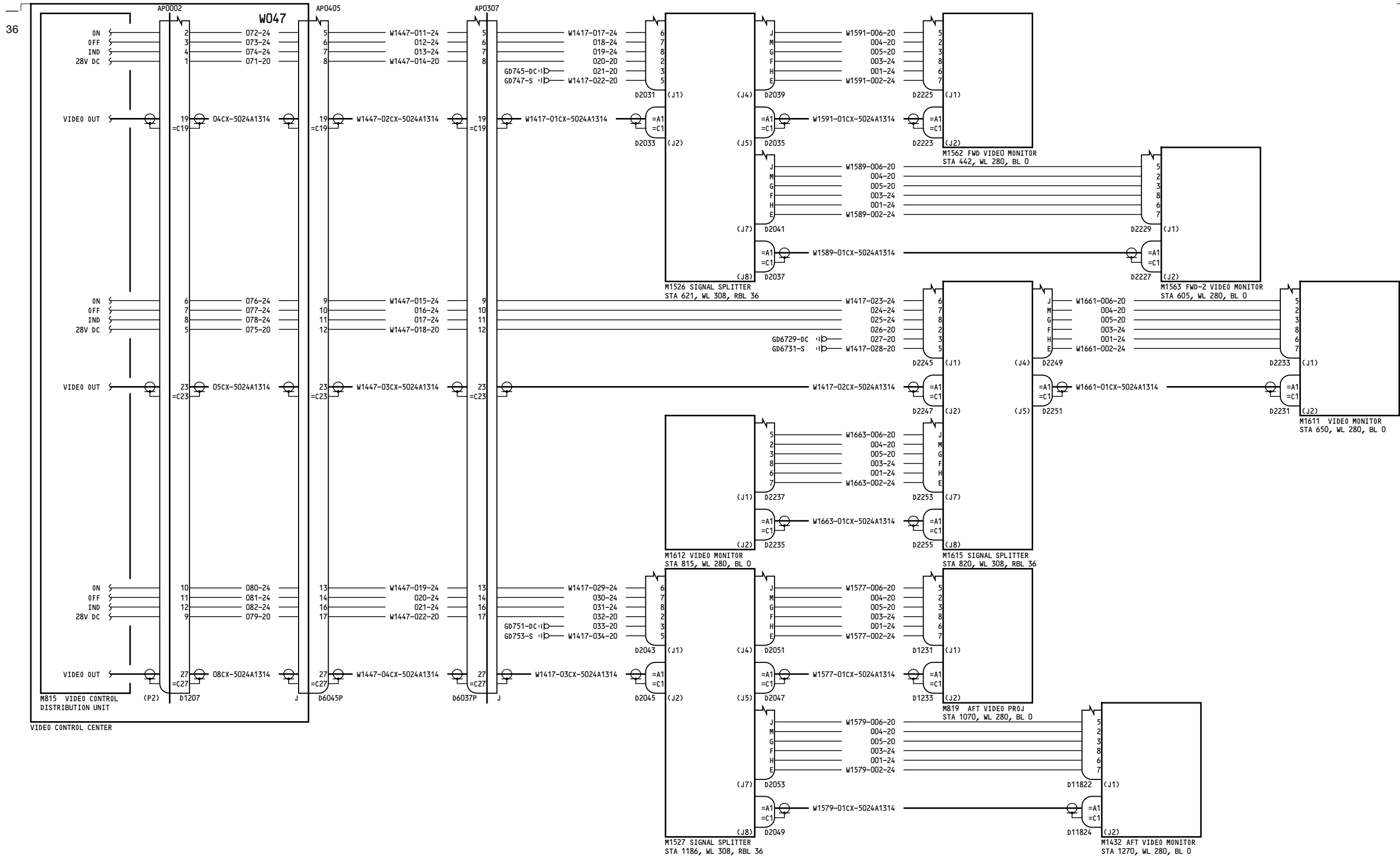

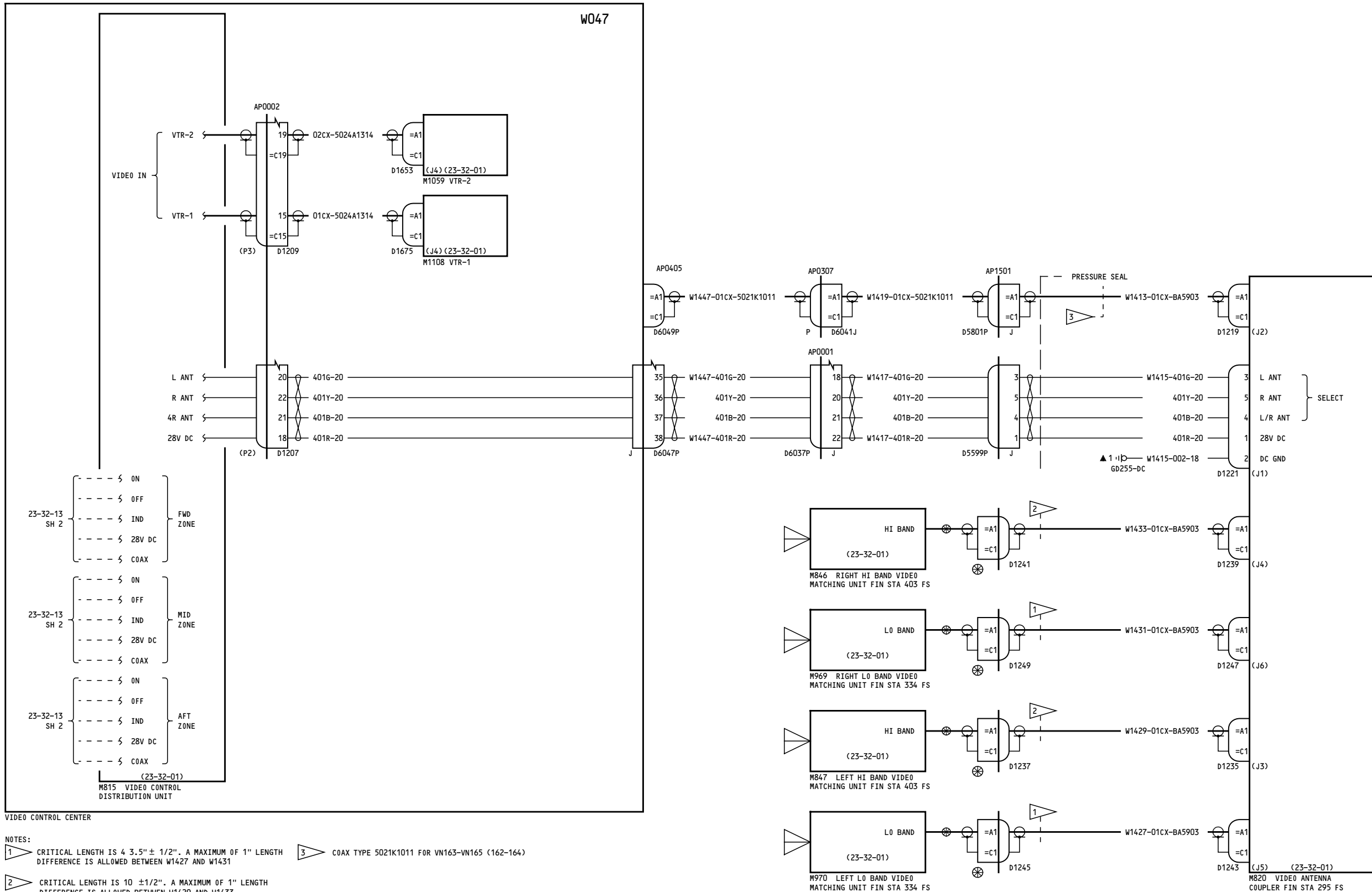

NOTES:
 1 CRITICAL LENGTH IS 4 3.5" ± 1/2". A MAXIMUM OF 1" LENGTH DIFFERENCE IS ALLOWED BETWEEN W1427 AND W1431
 2 CRITICAL LENGTH IS 10 ± 1/2". A MAXIMUM OF 1" LENGTH DIFFERENCE IS ALLOWED BETWEEN W1429 AND W1433
 3 COAX TYPE 5021K1011 FOR VN163-VN165 (162-164)

162-167	VIDEO PROJECTION-DISTRIBUTION
	D280T132

23-32-13

Page 5A
 Sheet 1
 Jan 21/2005

23-32-13

Page 5A
 Sheet 1
 Jan 21/2005

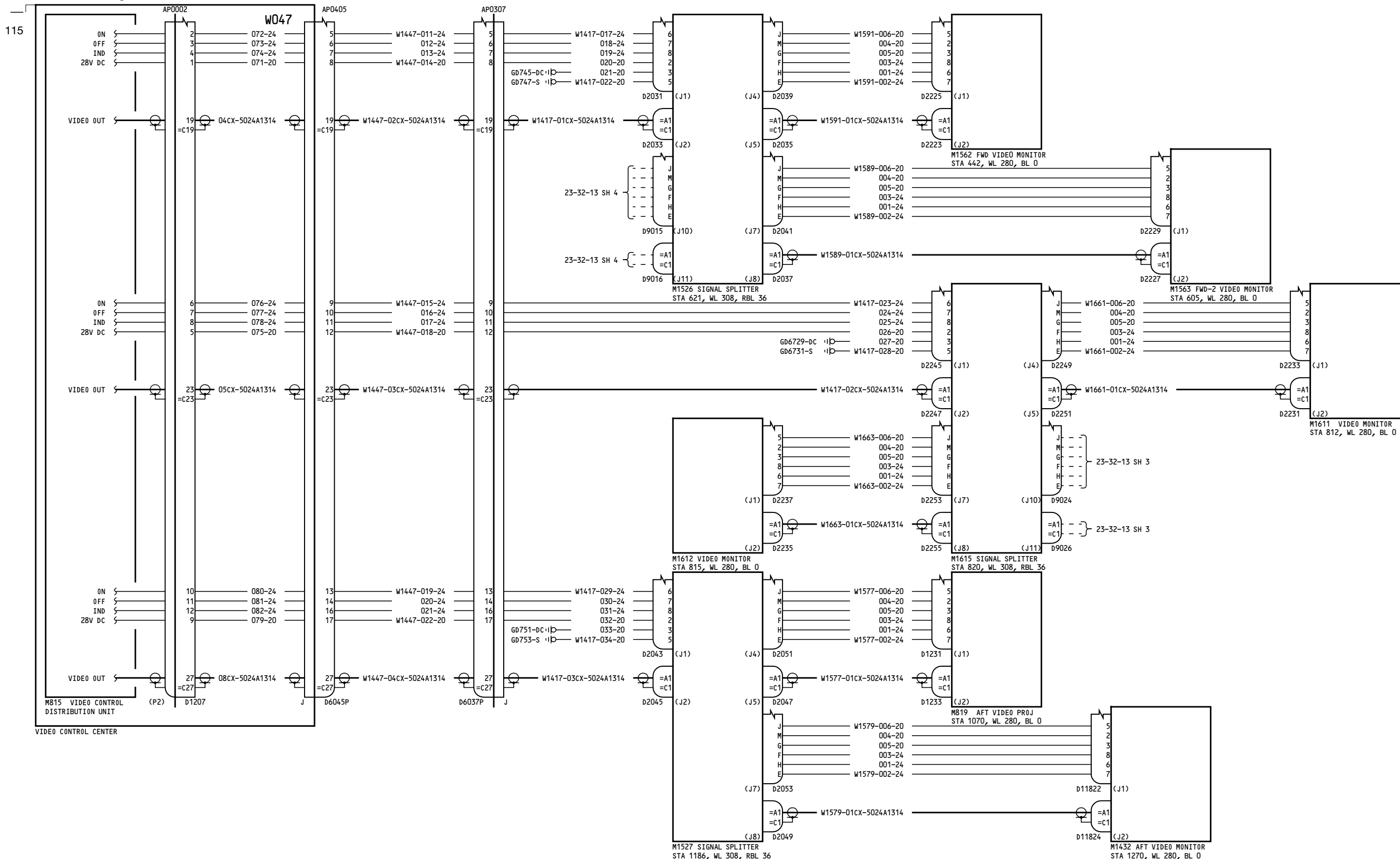

162-167

VIDEO PROJECTION-DISTRIBUTION

D280T132

23-32-13

Page 5A
Sheet 2
Jan 21/2005

Incorporates
MTO 230532

23-32-13

Page 5A
Sheet 2
Jan 21/2005

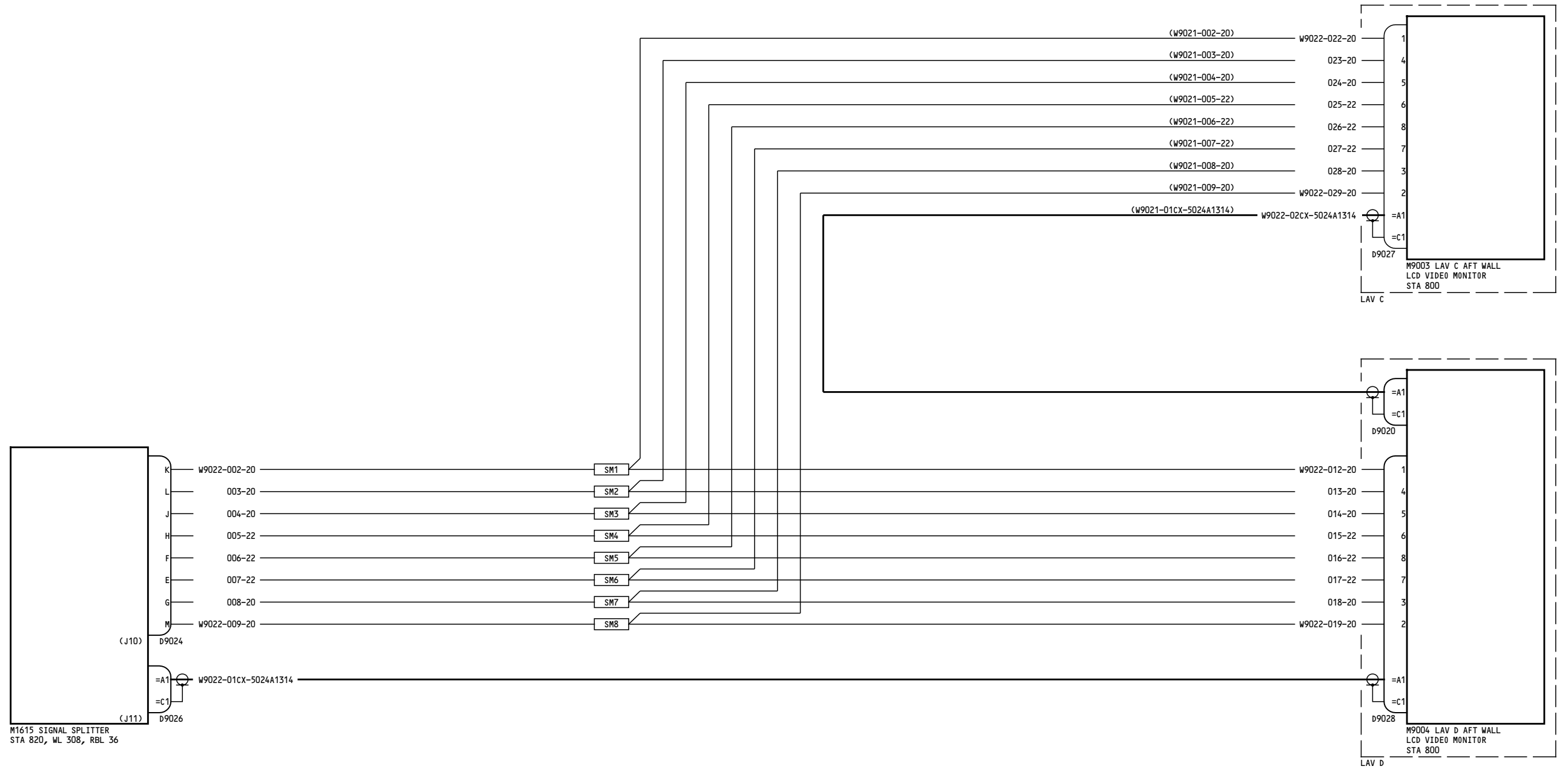

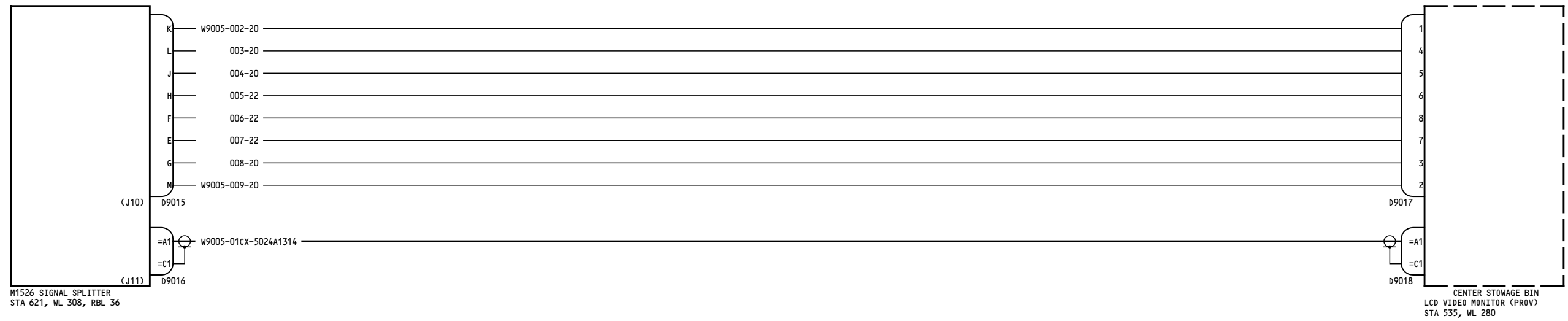

162-167

**VIDEO PROJECTION-
DISTRIBUTION**

D280T132

23-32-13

Page 5A
Sheet 4
Jan 21/2005

Incorporates
▶ MTO 230532

23-32-13

Page 5A
Sheet 4
Jan 21/2005

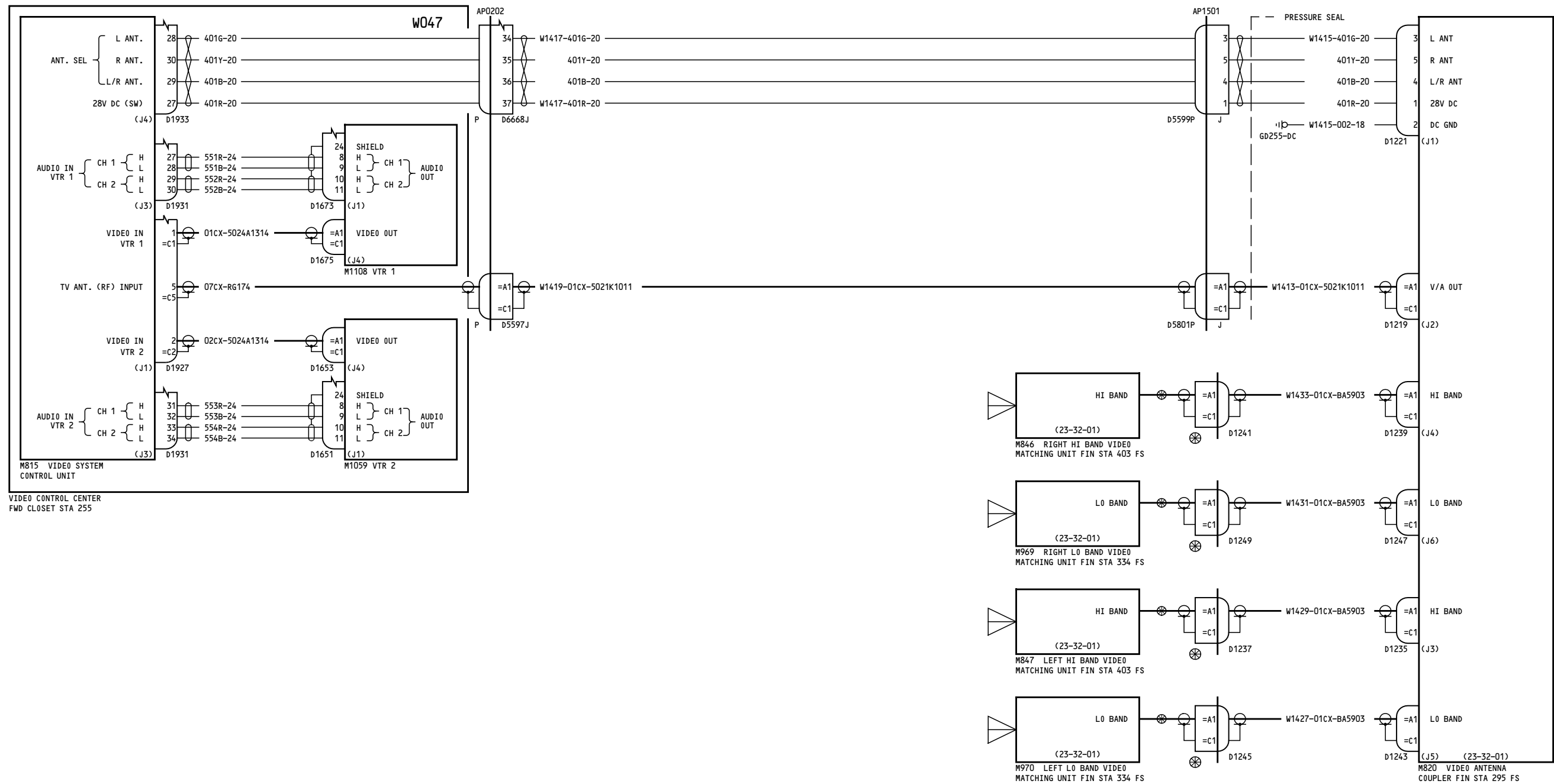

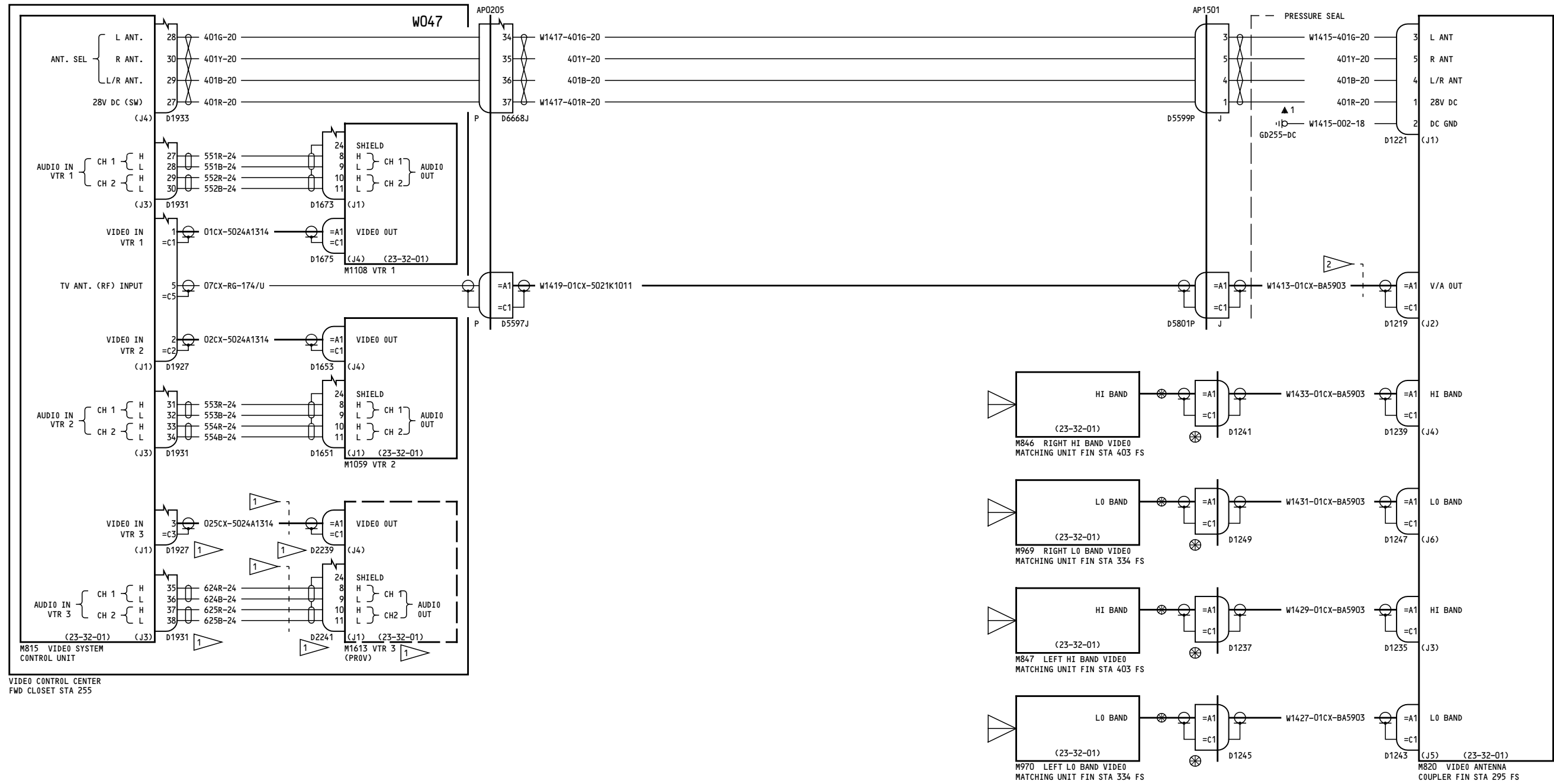

NOTES:
 1 VN671-VN675 (279-999)
 2 COAX TYPE 5021K1011 FOR VN222-VN222 (276)

276-299	VIDEO PROJECTION- DISTRIBUTION D280T132
---------	-----------------------------------------------------------

23-32-13

23-32-13

-A

72

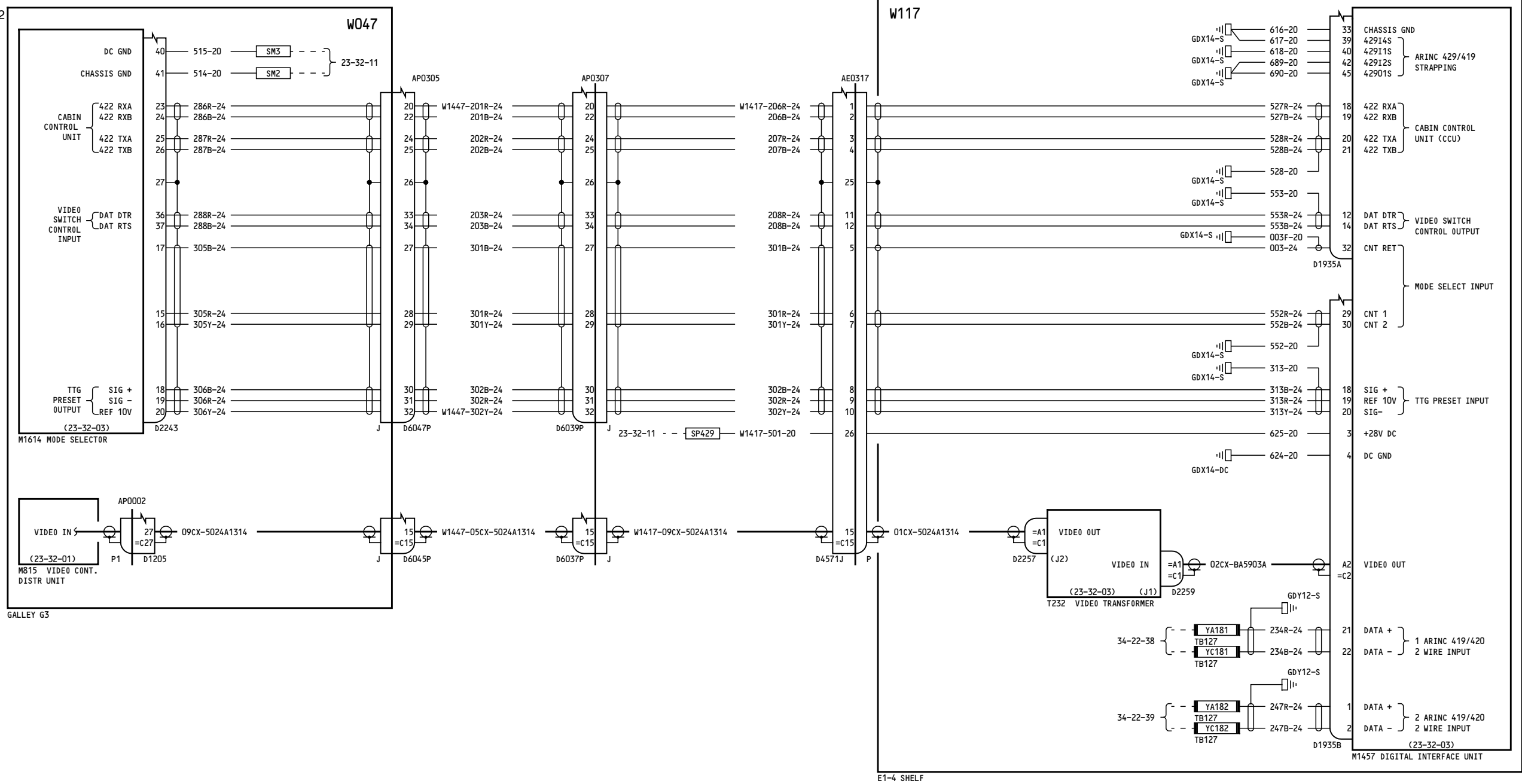

E1-4 SHELF

050-051

**VIDEO PROJECTION
PASSENGER ENROUTE DISPLAY
SYSTEM**

23-32-21

Incorporates
MTO 230540

23-32-21

Page 1A

Page 1A

D280T132

Jan 21/2005

Jan 21/2005

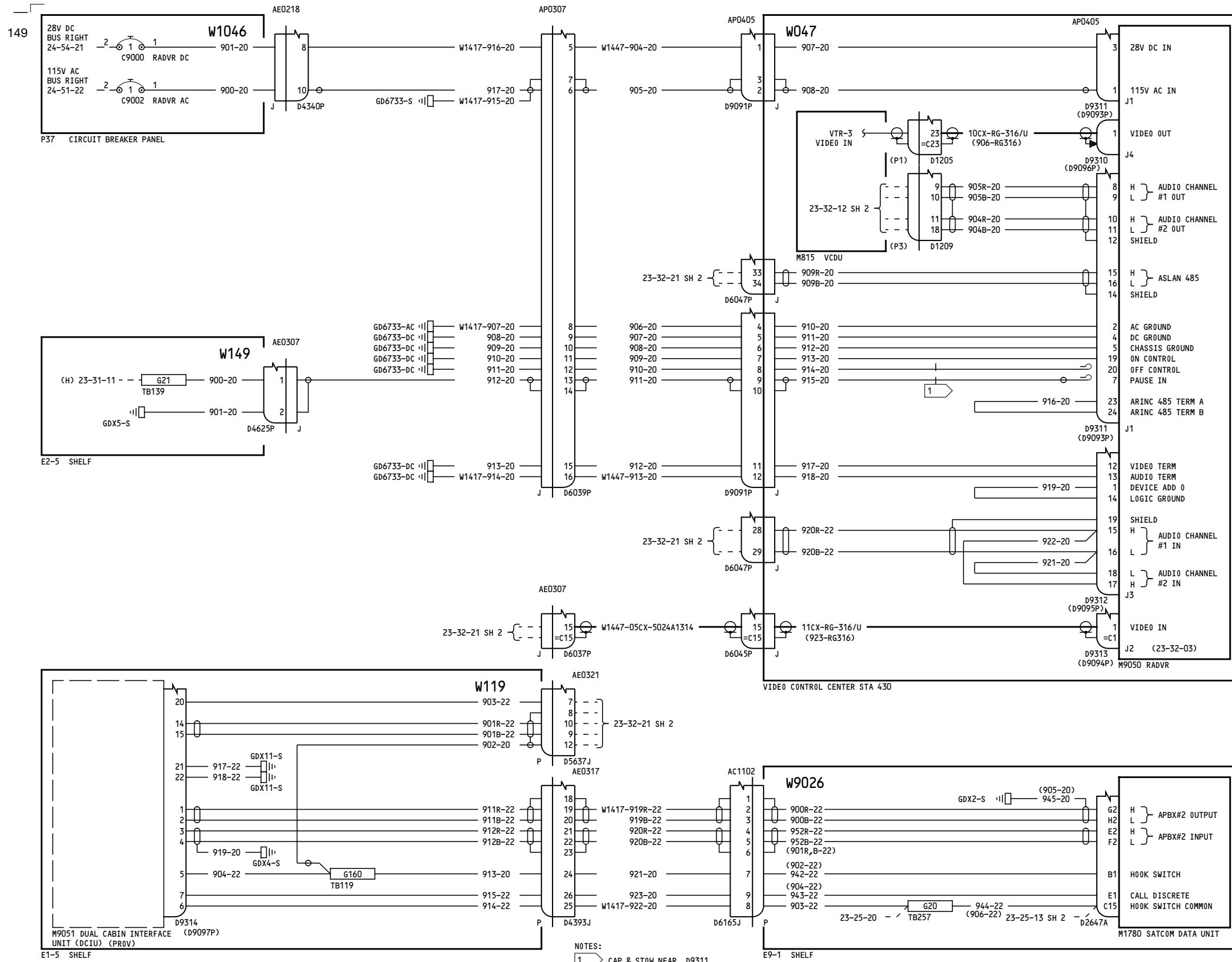

150, 153-154

VIDEO PROJECTION PASSENGER ENROUTE DISPLAY SYSTEM

D280T132

23-32-21

Page 2A
Sheet 1
Jan 21/2005

Incorporates
MTO 230524
MTO-230718

23-32-21

Page 2A
Sheet 1
Jan 21/2005

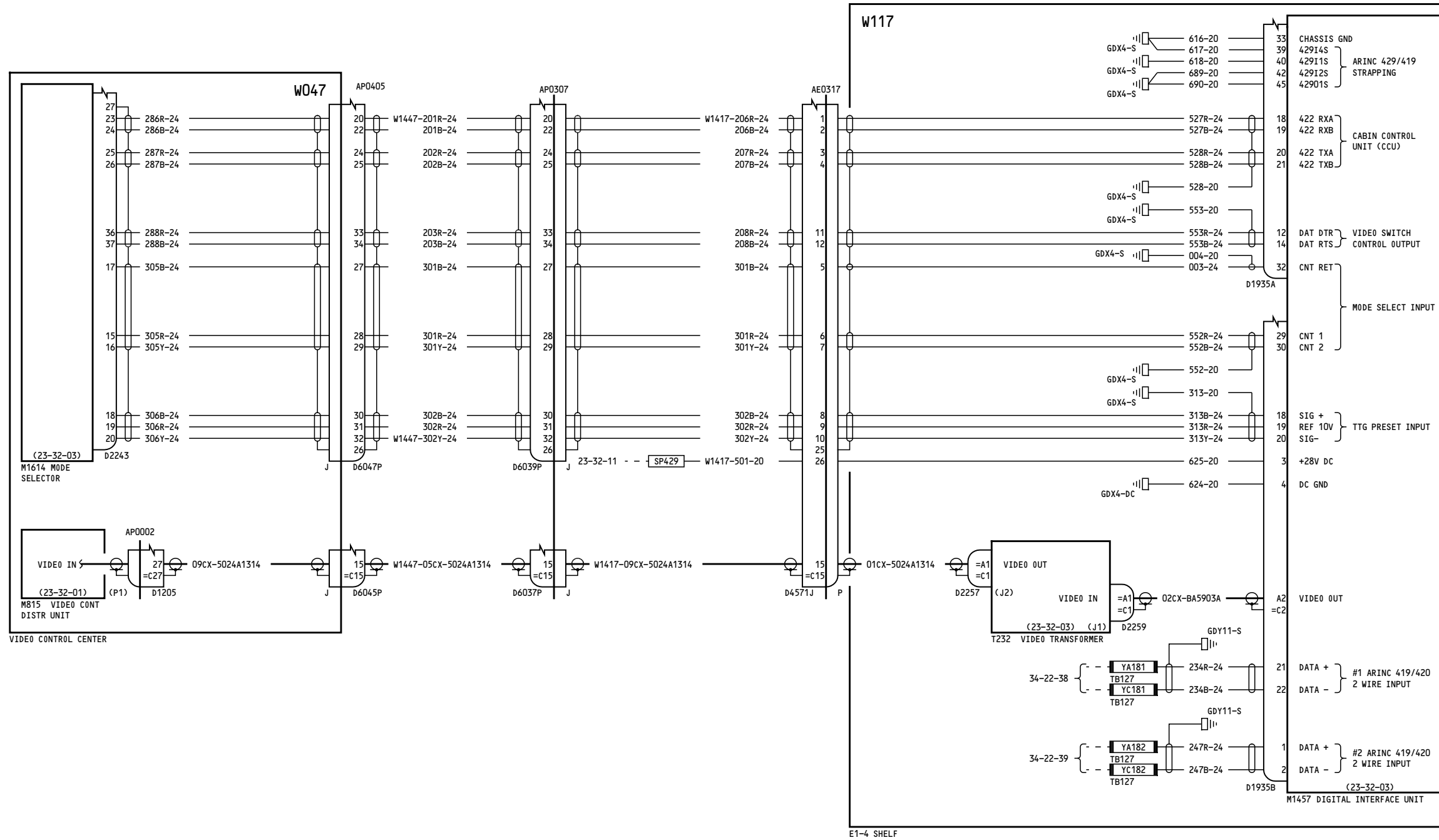

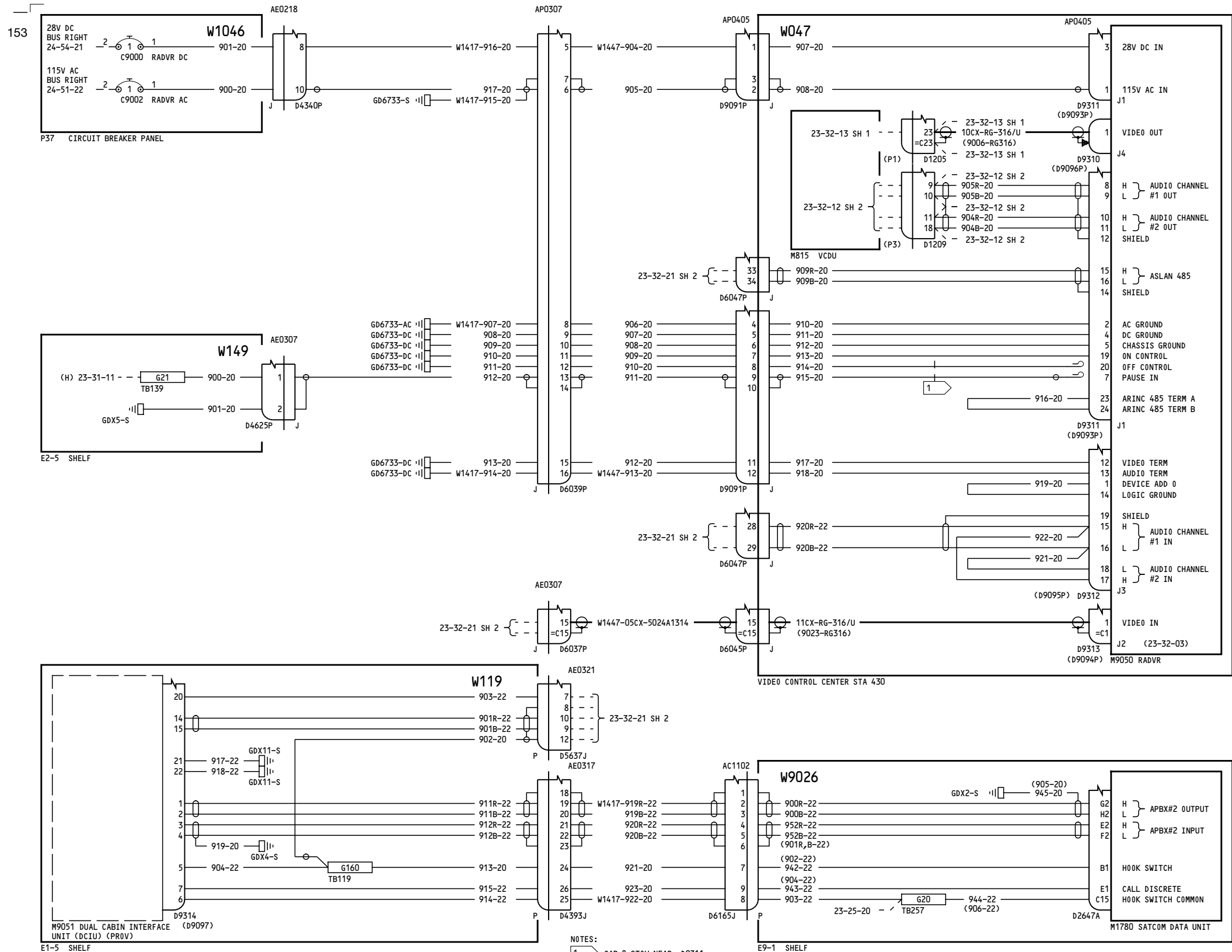

-A

42

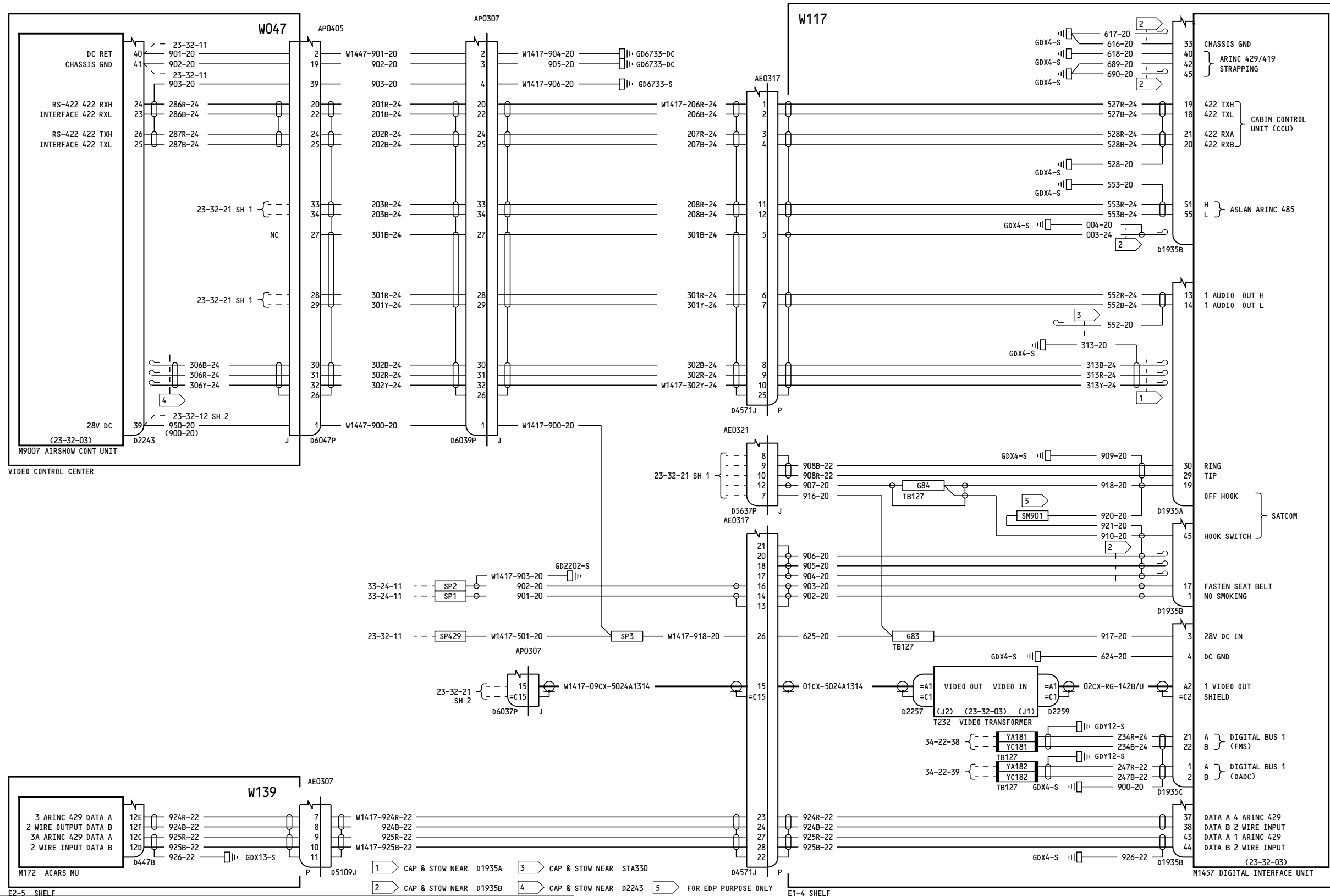

152

VIDEO PROJECTION PASSENGER ENROUTE DISPLAY SYSTEM

23-32-21

Page 4A Sheet 2 Jan 21/2005

D280T132

Incorporates MTO-230718

23-32-21

Page 4A Sheet 2 Jan 21/2005

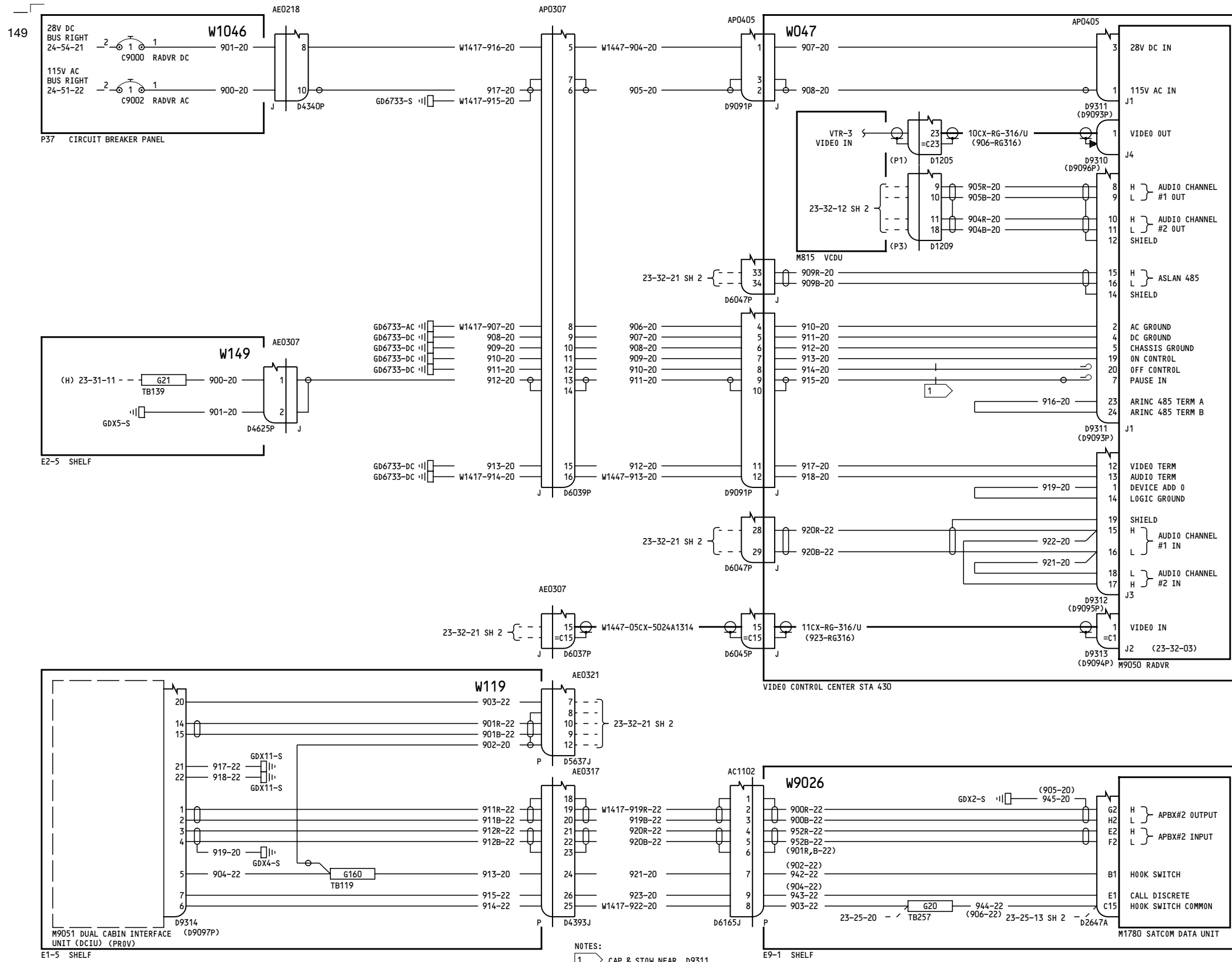

155-156, 162-167

**VIDEO PROJECTION
PASSENGER ENROUTE DISPLAY
SYSTEM**

D280T132

23-32-21

Page 5A
Sheet 1
Jan 21/2005

Incorporates
 MTO 230524
 MTO-230718

23-32-21

Page 5A
Sheet 1
Jan 21/2005

-A
47

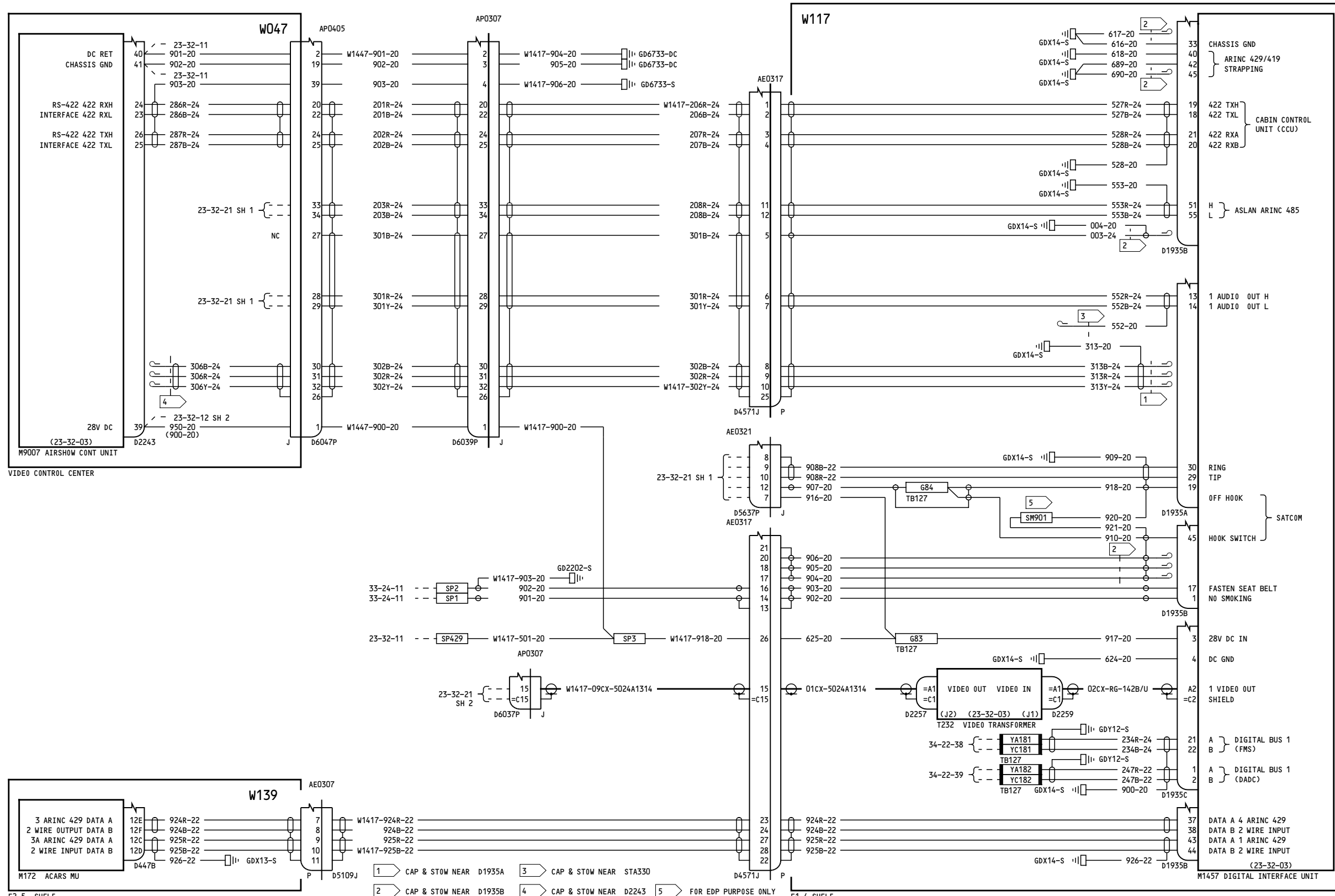

E2-5 SHELF
155-156, 162-167

**VIDEO PROJECTION
PASSENGER ENROUTE DISPLAY
SYSTEM**

D280T132

23-32-21

Page 5A
Sheet 2
Jan 21/2005

Incorporates
MTO-230718

23-32-21

Page 5A
Sheet 2
Jan 21/2005

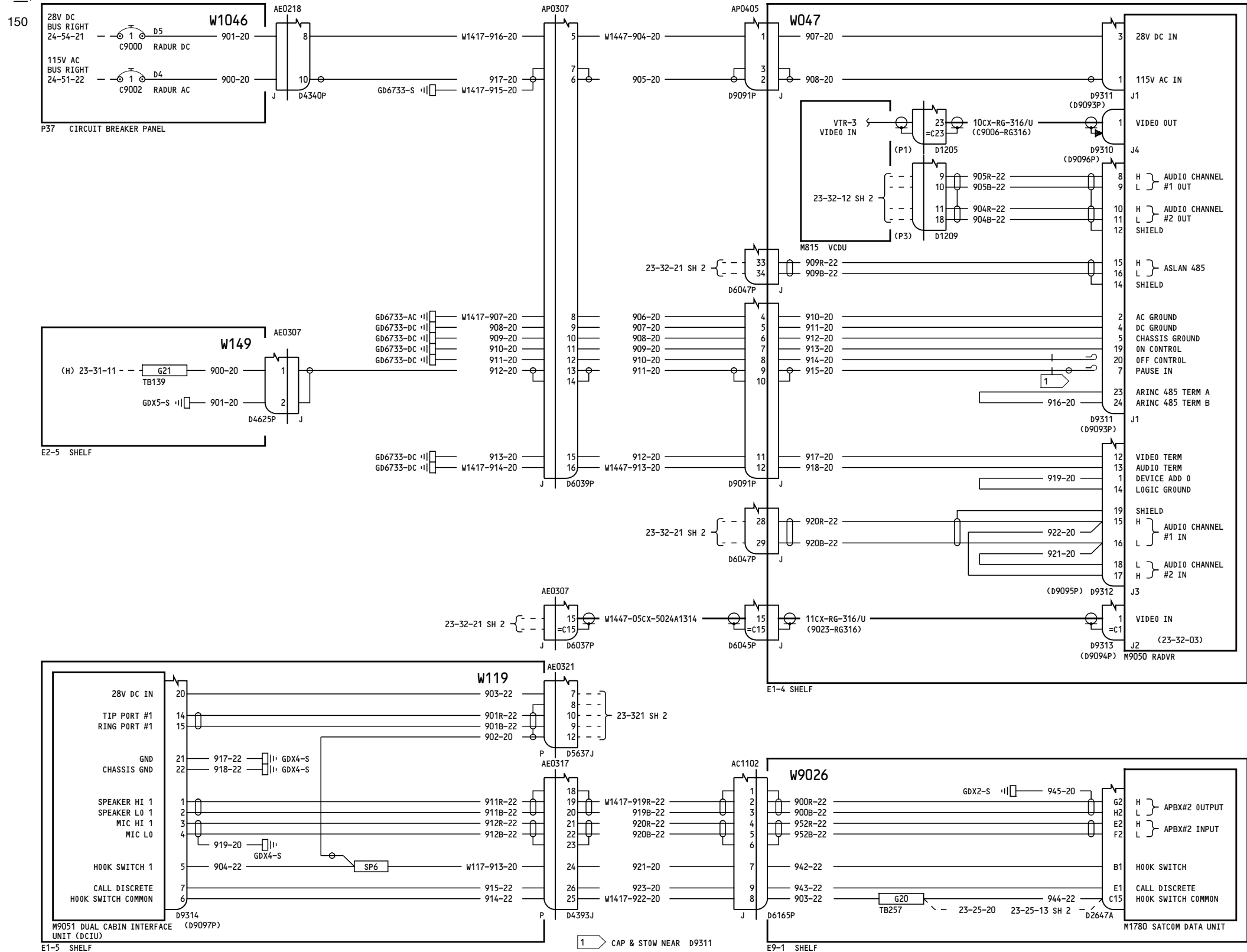

157

VIDEO PROJECTION PASSENGER ENROUTE DISPLAY SYSTEM

D280T132

23-32-21

Page 6A Sheet 1 Jan 21/2005

Incorporates MTO 230524 MTO-230718

23-32-21

Page 6A Sheet 1 Jan 21/2005

-A

43

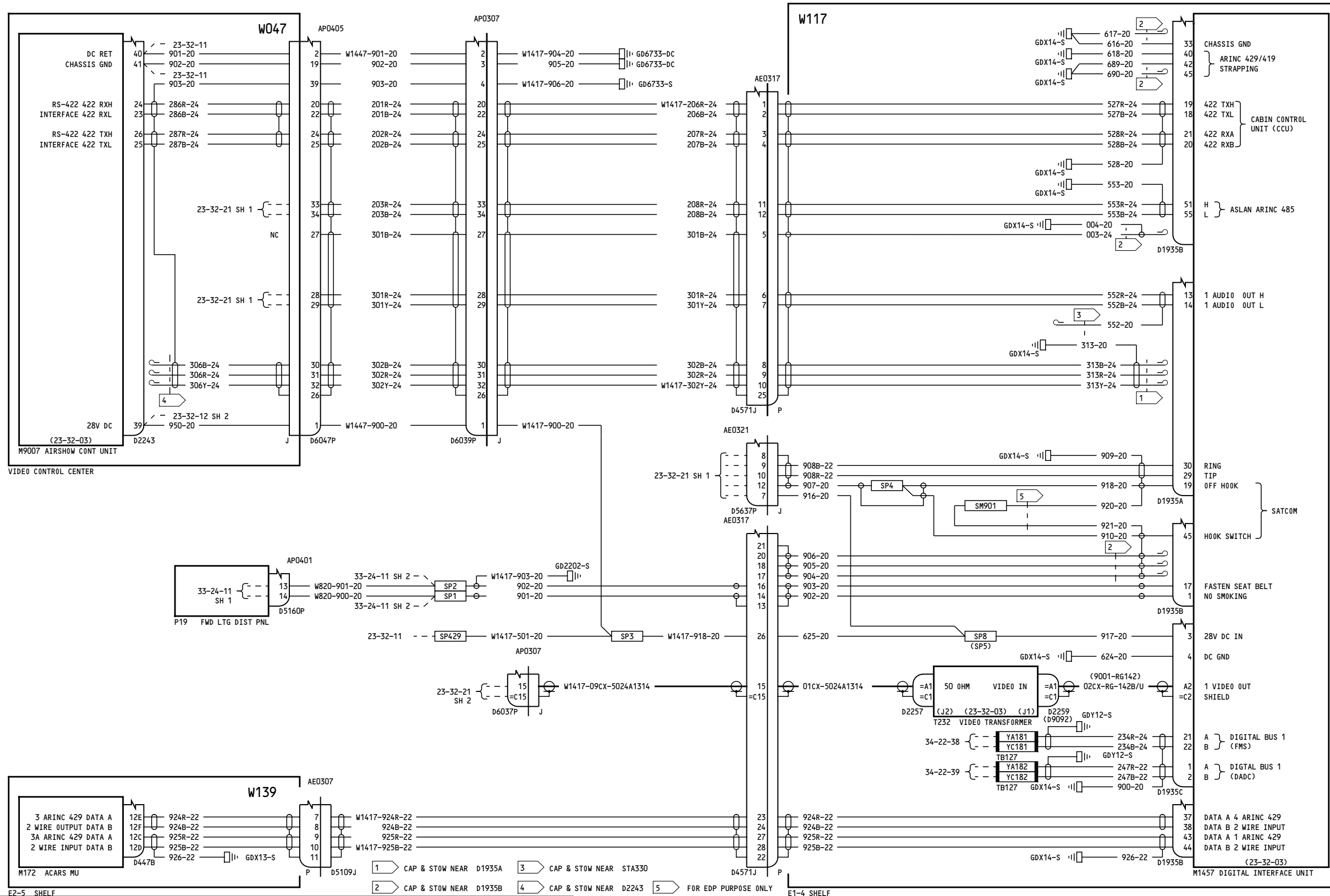

E2-5 SHELF

E1-4 SHELF

**VIDEO PROJECTION
PASSENGER ENROUTE DISPLAY
SYSTEM**

23-32-21

Page 6A
Sheet 2
Jan 21/2005

D280T132

Incorporates
MTO-230718

23-32-21

Page 6A
Sheet 2
Jan 21/2005

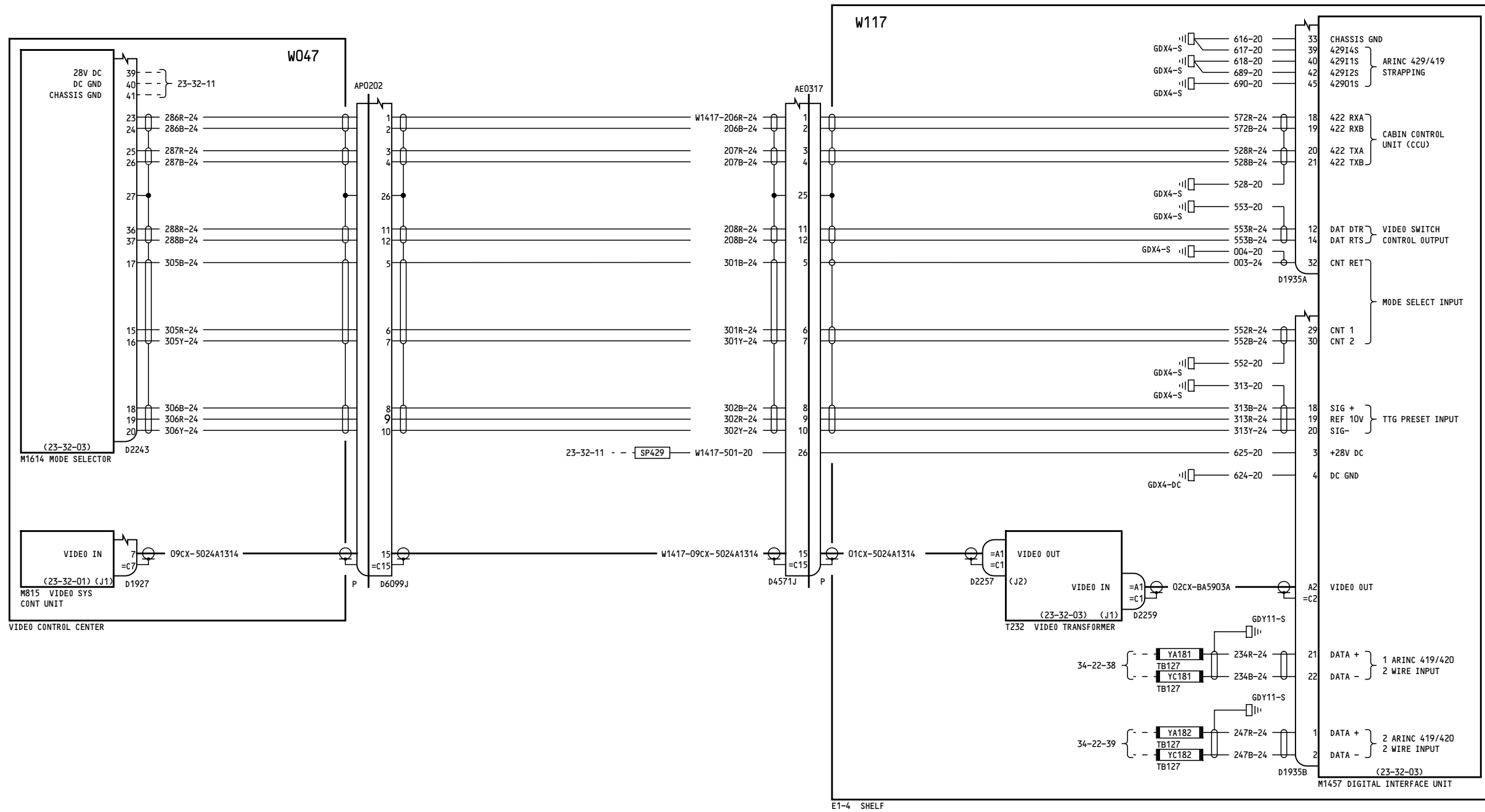

-B
7

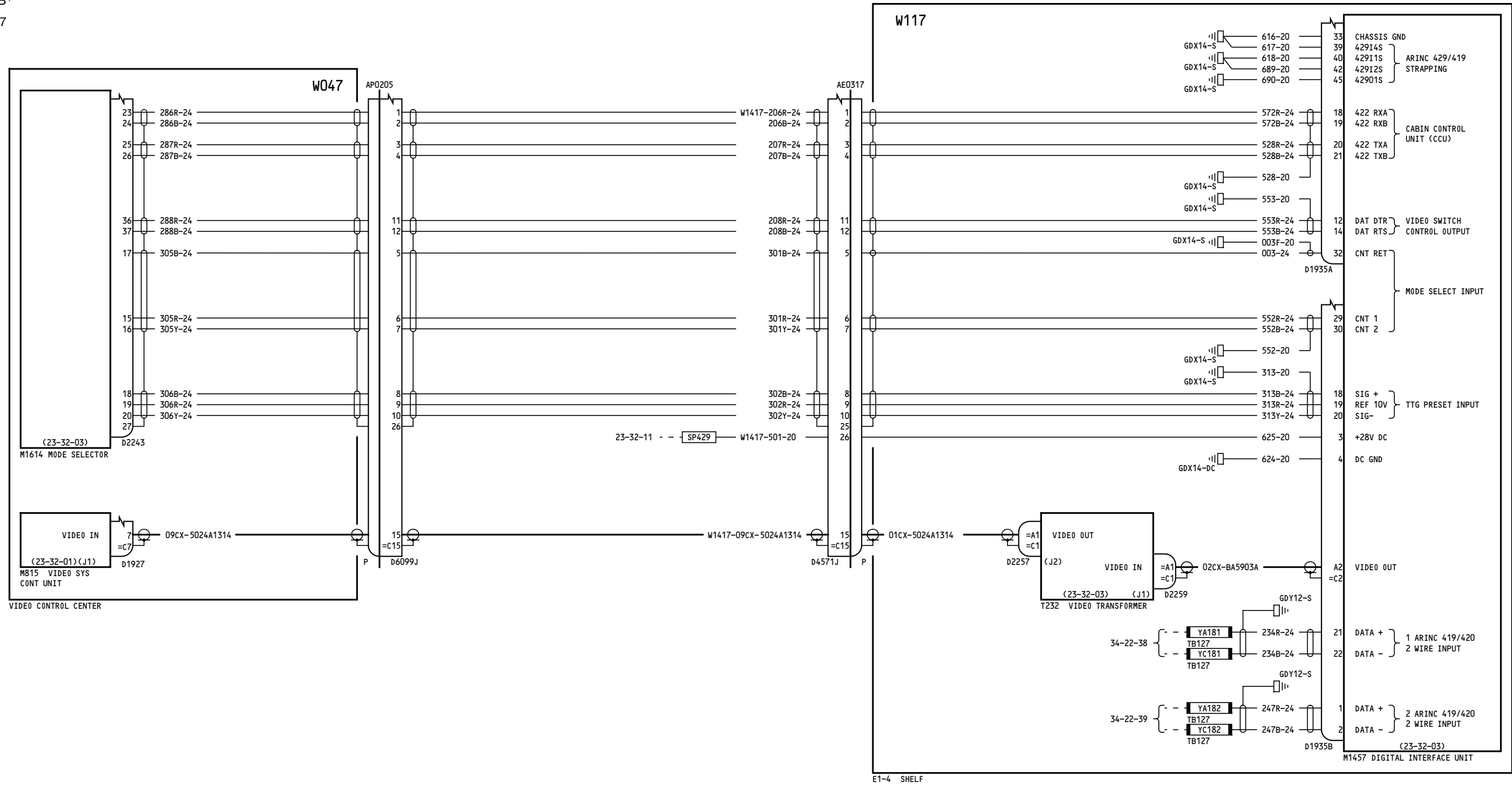

276-278

**VIDEO PROJECTION
PASSENGER ENROUTE DISPLAY
SYSTEM**

23-32-21

23-32-21

Page 8

Page 8

D280T132

Jan 21/2005

Jan 21/2005

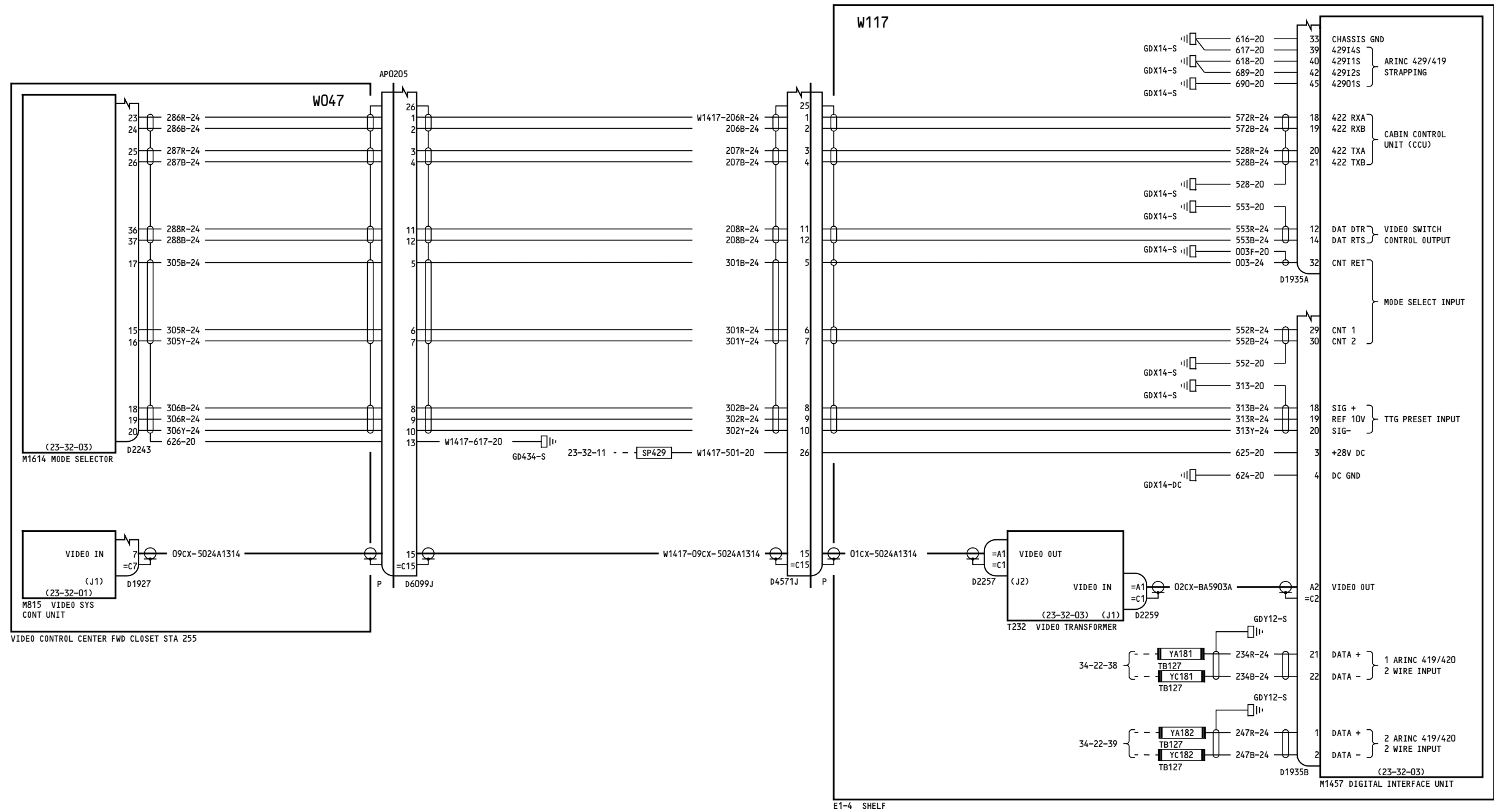

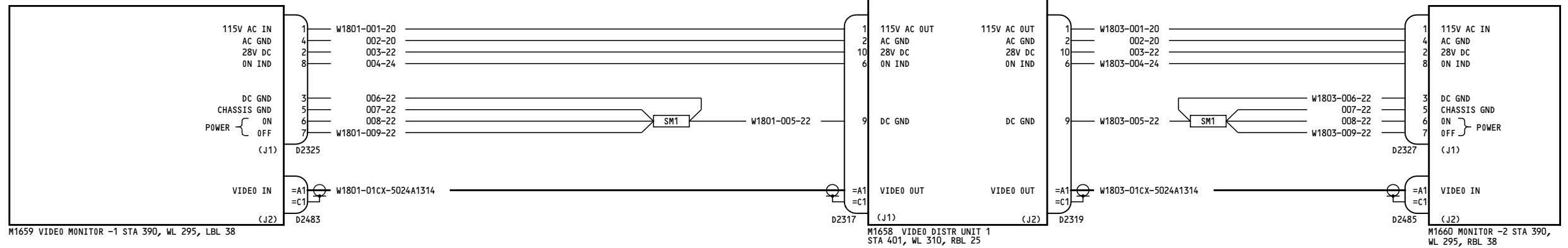
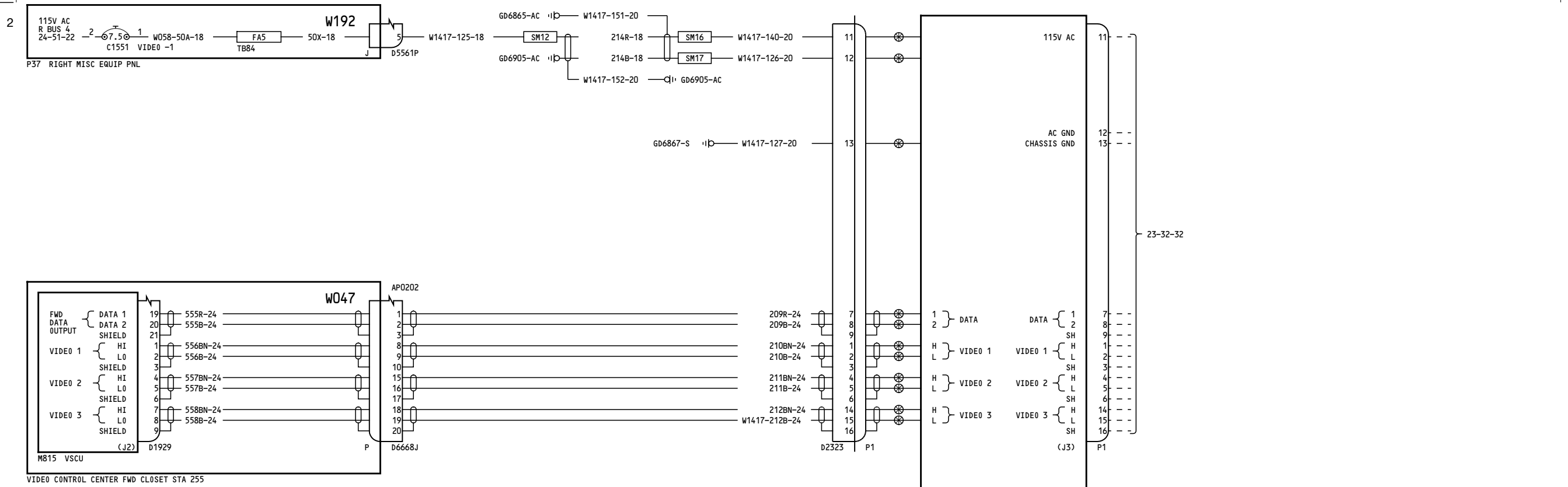

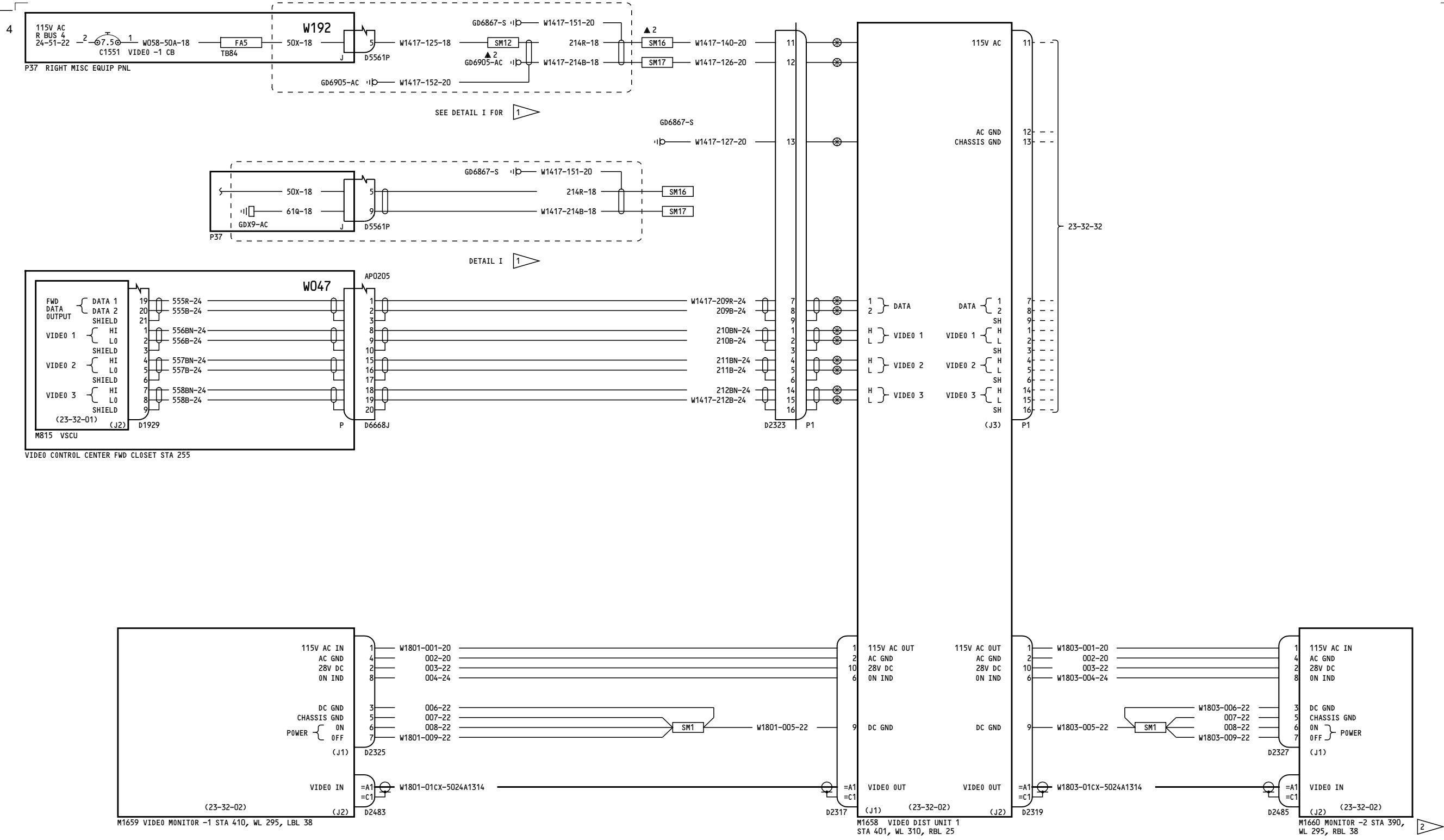

NOTES:
 1 VLN223-VN230, VN671-VN675
 2 STA 410 FOR VN223-VN230, VN671-VN675

276-299	VIDEO ENTERTAINMENT SYSTEM-VIDEO-1 D280T132
---------	-----------------------------------------------------------

23-32-31

Page 2
 Jan 21/2005

23-32-31

Page 2
 Jan 21/2005

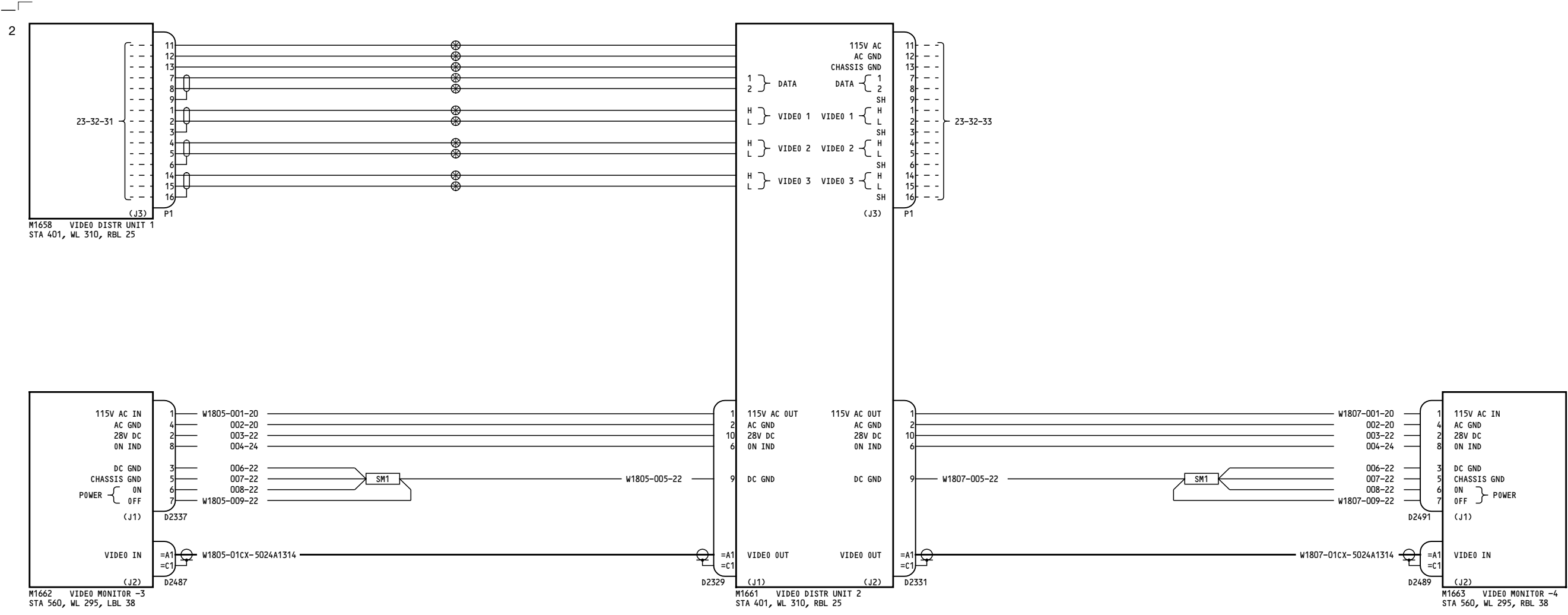

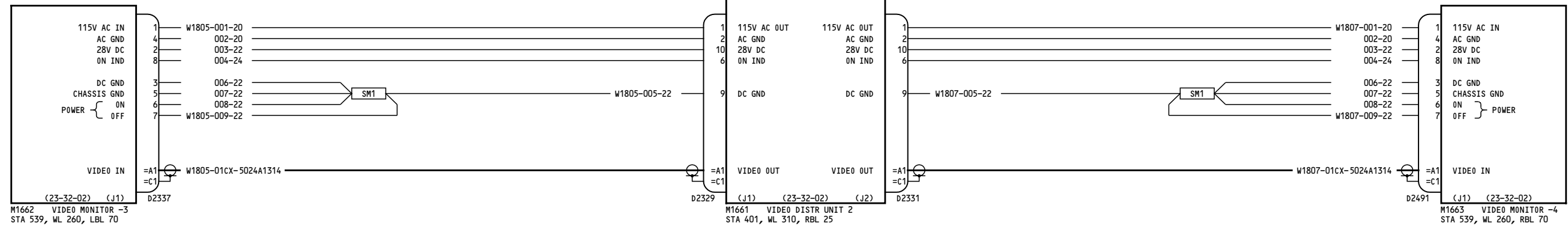
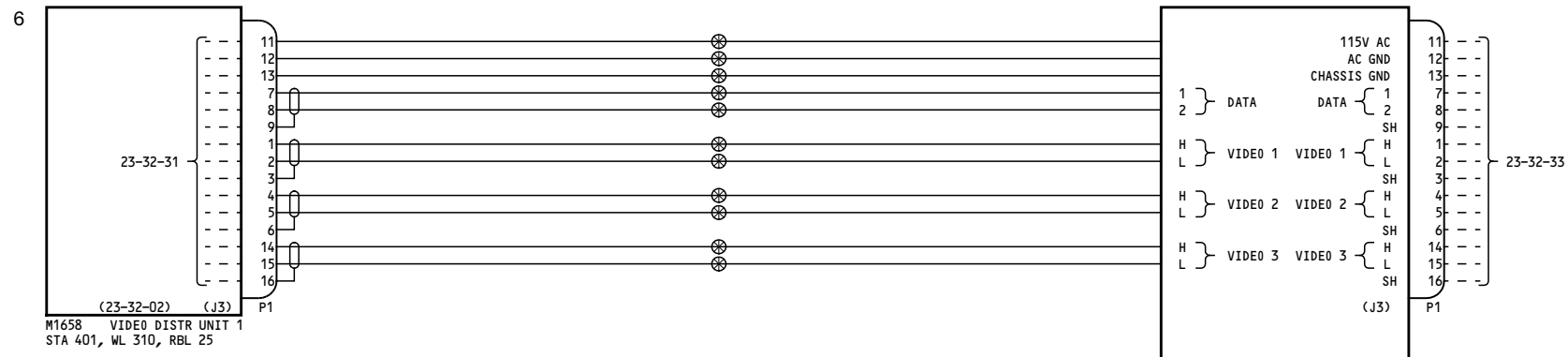

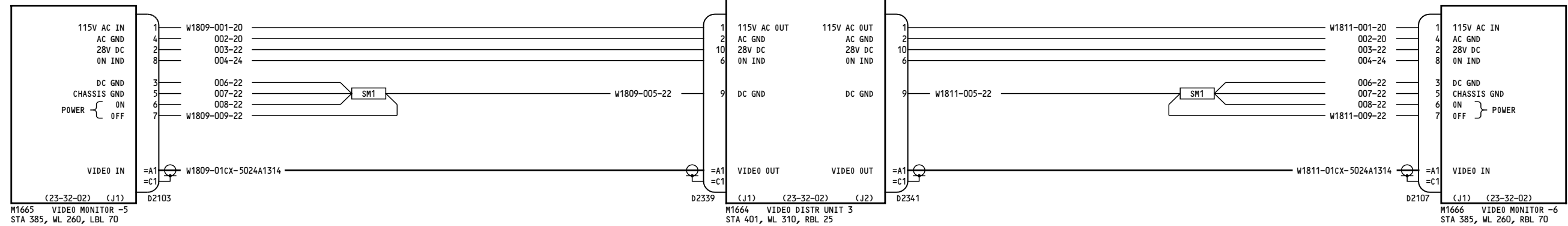
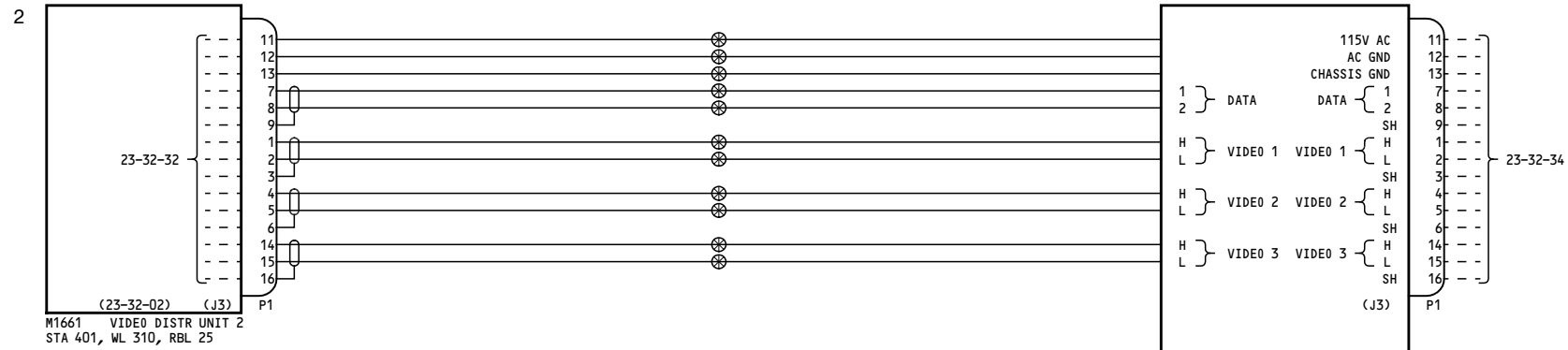

1

NOTES:
1 M1665 PROVISIONAL FOR VN671-VN675 (279-999)

275-299	<p align="center">VIDEO ENTERTAINMENT SYSTEM-VIDEO 1</p> <p align="center">D280T132</p>
---------	------------------------------------------------------------------------------------------------

23-32-33

Page 1
Jan 21/2005

23-32-33

Page 1
Jan 21/2005

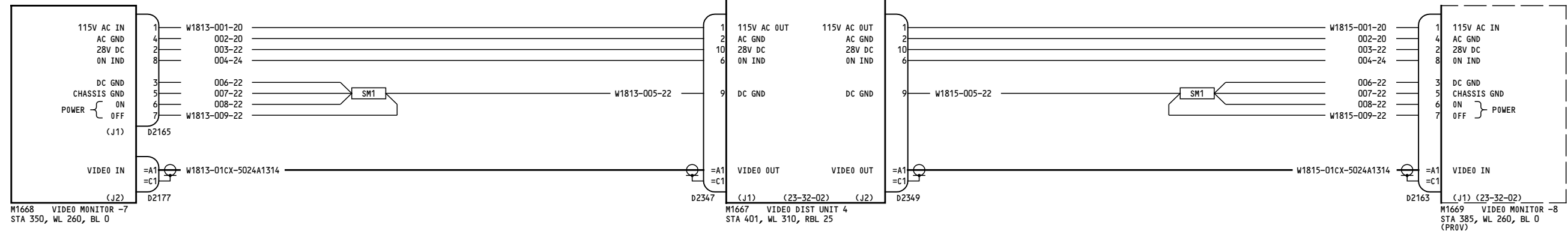
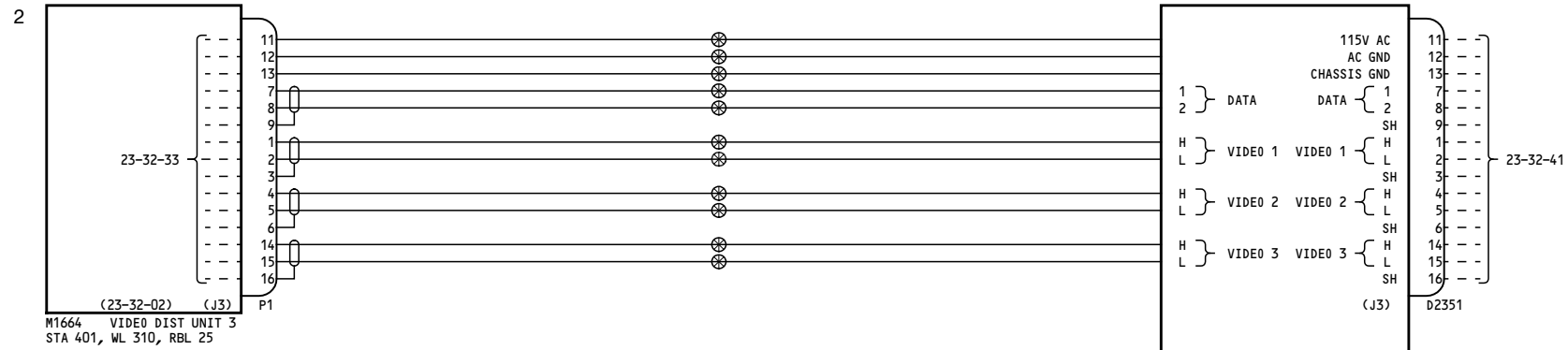

1 STA 375 FOR VN223-VN230

275-278	VIDEO ENTERTAINMENT SYSTEM-VIDEO 1
	D280T132

23-32-34

Page 1

Jan 21/2005

23-32-34

Page 1

Jan 21/2005

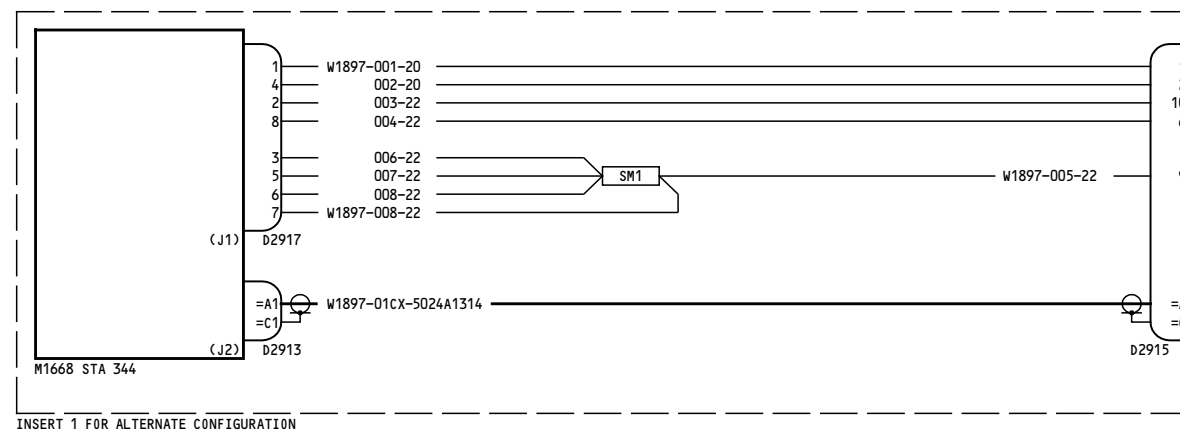
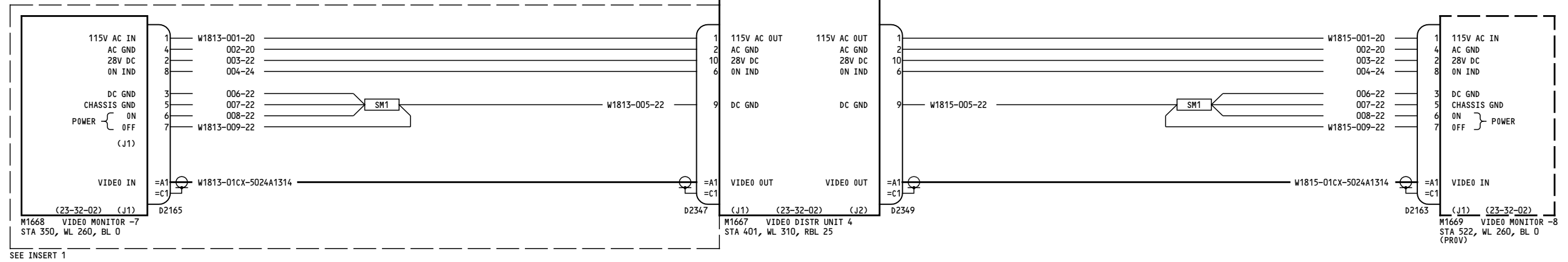
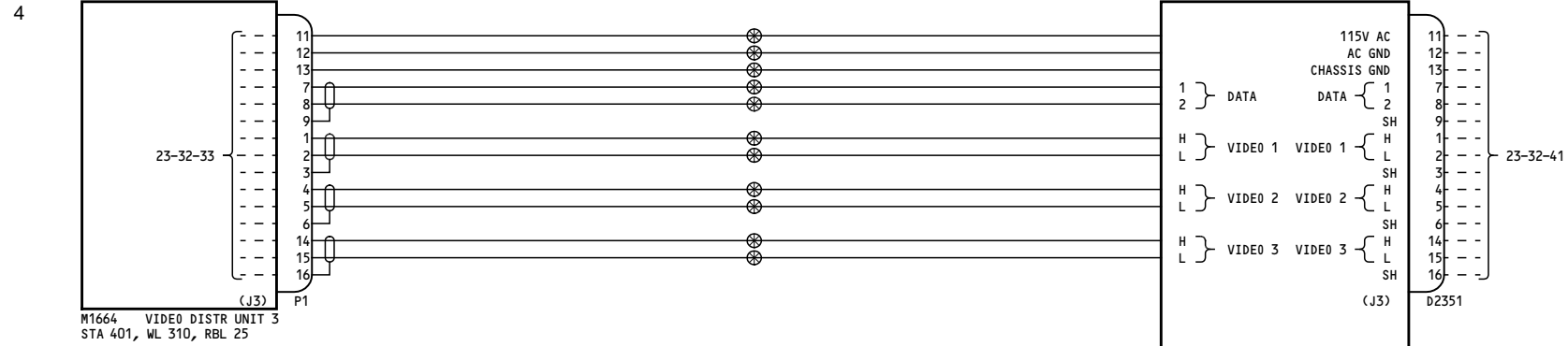

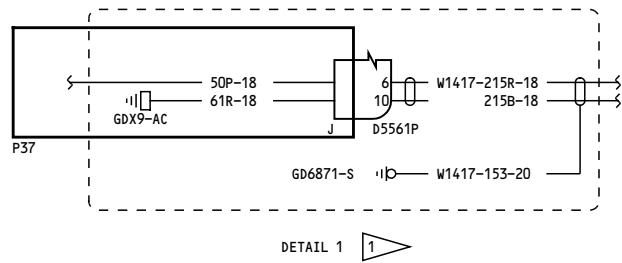
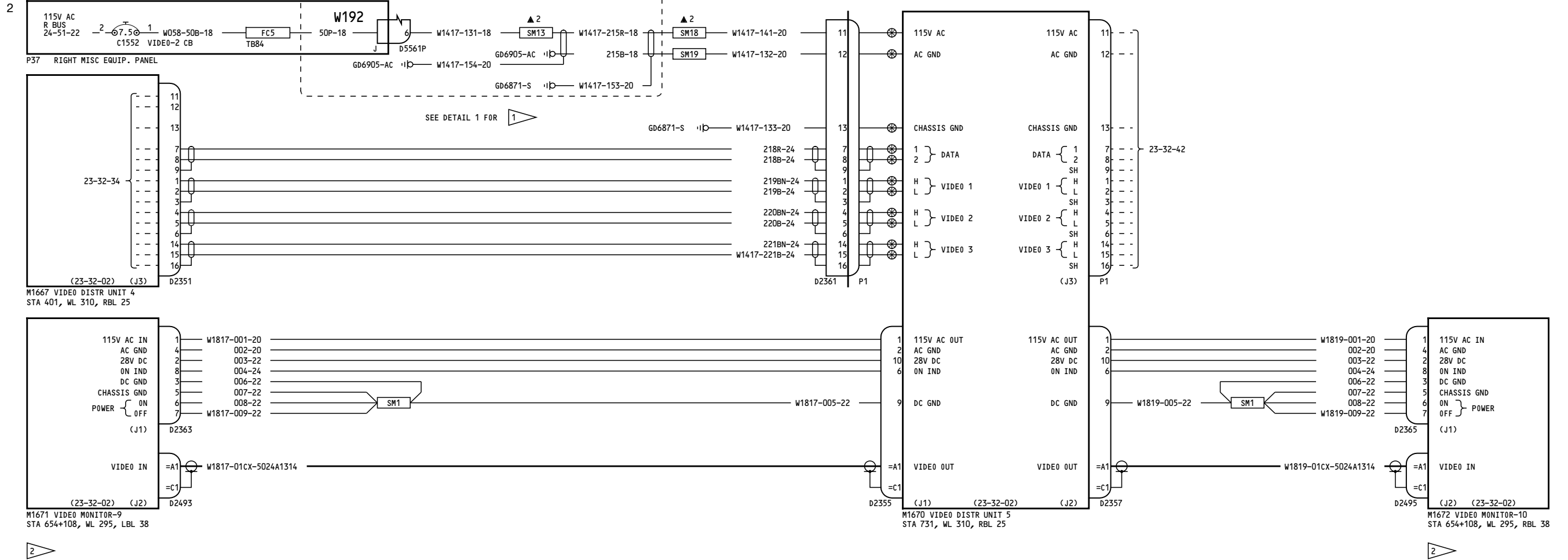

NOTES:
 1 VN223-VN230, VN671-VN675
 2 STA 645+115 FOR VN671-VN67 (PROV)

275-299

VIDEO ENTERTAINMENT SYSTEM-VIDEO 2

D280T132

23-32-41

Page 1

Jan 21/2005

23-32-41

Page 1

Jan 21/2005

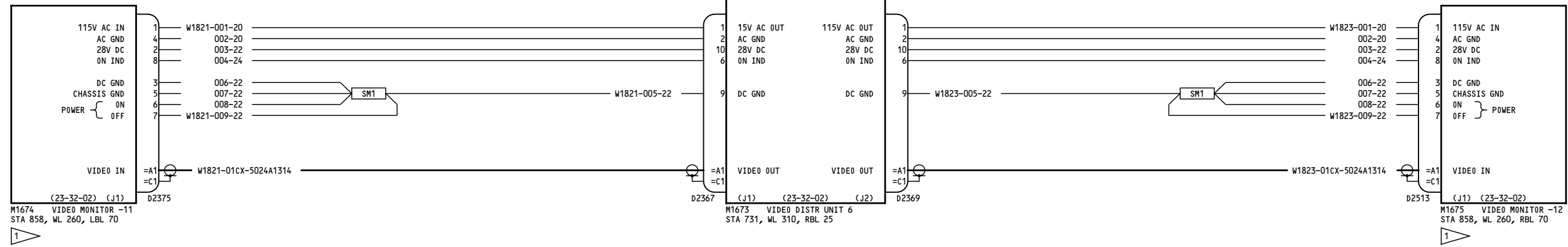
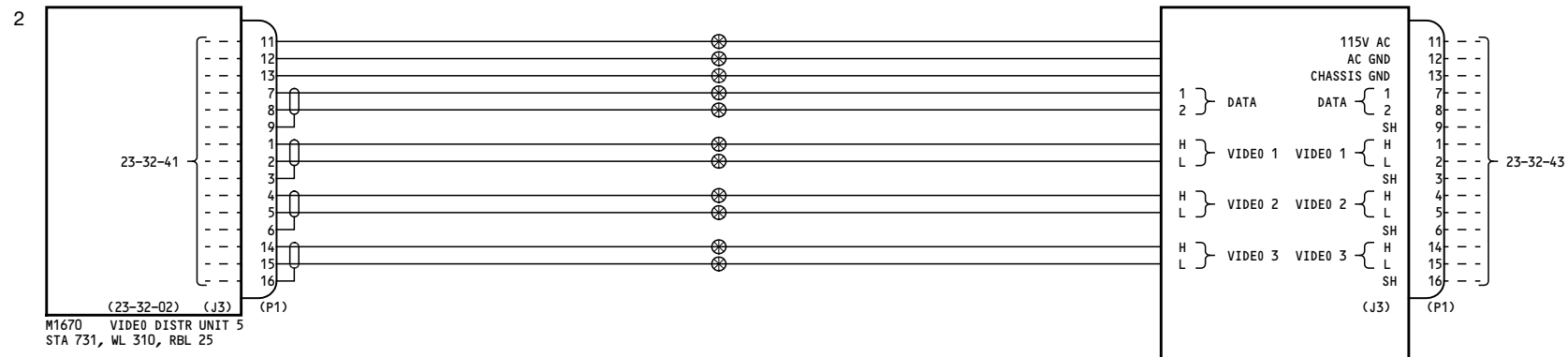

NOTES:
1 STA 654+72 PROVISIONAL FOR VN671-VN675 (279-999)

275-299

**VIDEO ENTERTAINMENT
SYSTEM-
VIDEO 2**

23-32-42

Page 1

D280T132

Jan 21/2005

23-32-42

Page 1

Jan 21/2005

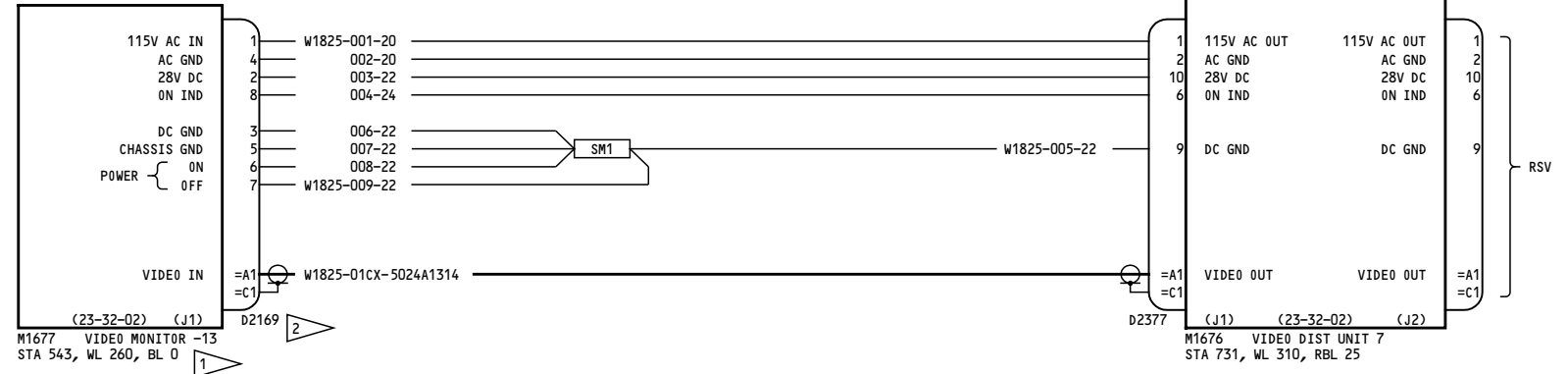
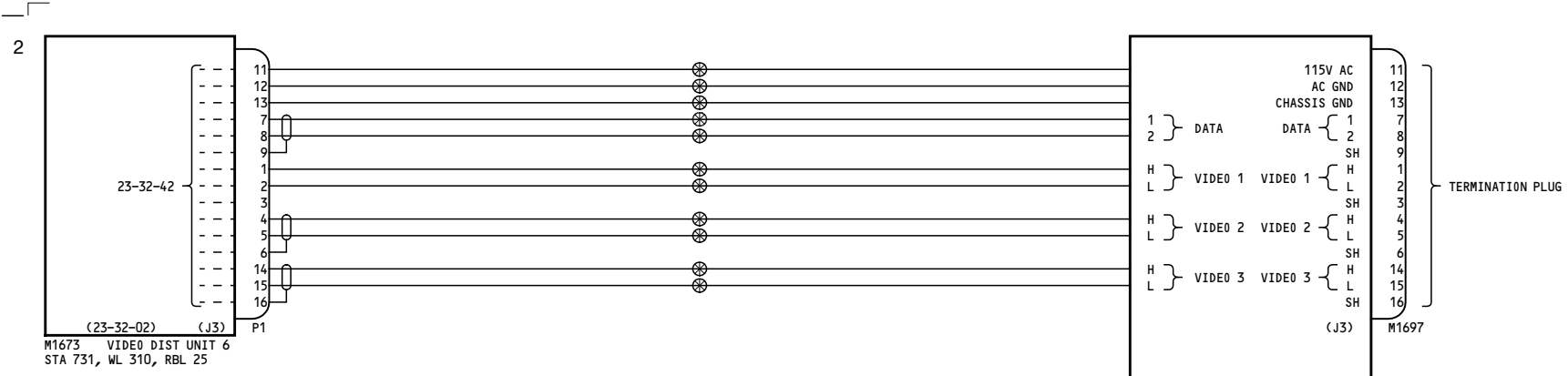

- 1 INSTALLED IN ALTERNATE CONFIGURATION
- 2 CAP AND STOW CONNECTOR NEAR STA 543

275-278	VIDEO ENTERTAINMENT SYSTEM-VIDEO 2	
	D280T132	

23-32-43

Page 1
Jan 21/2005

23-32-43

Page 1
Jan 21/2005

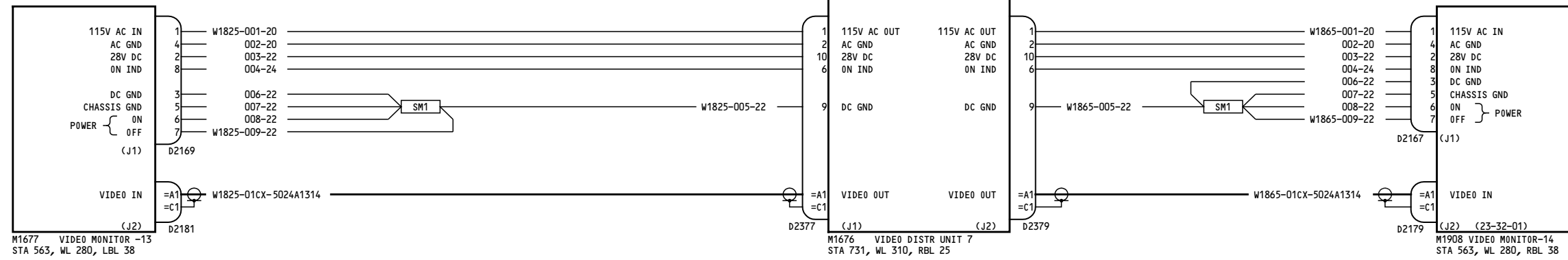
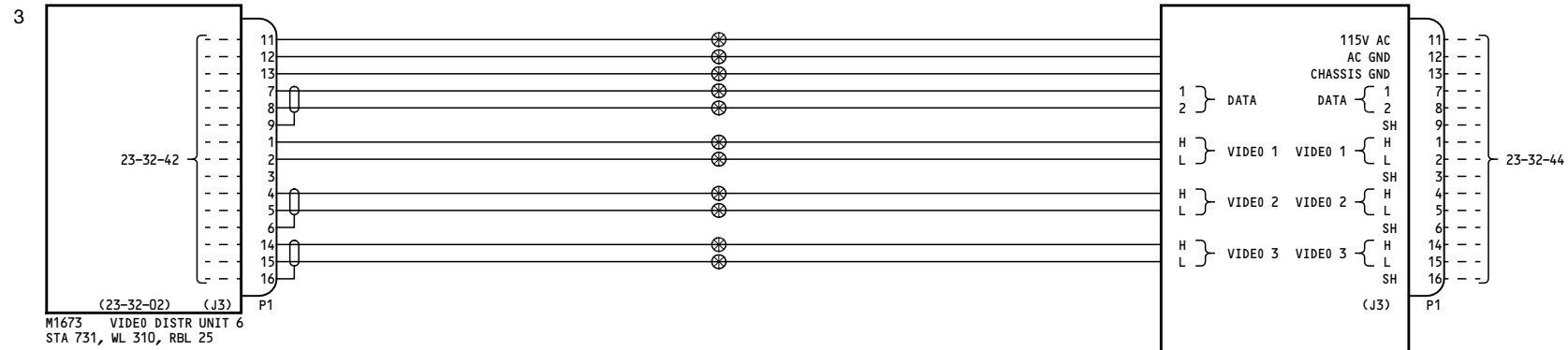

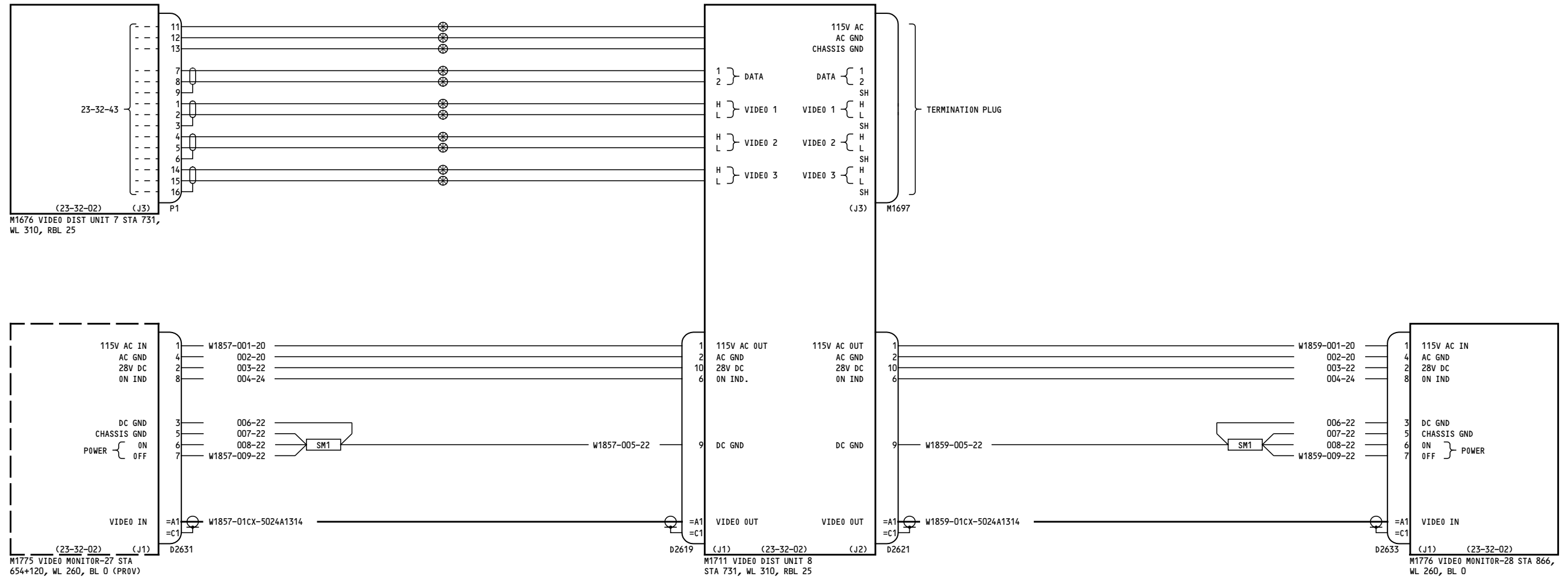

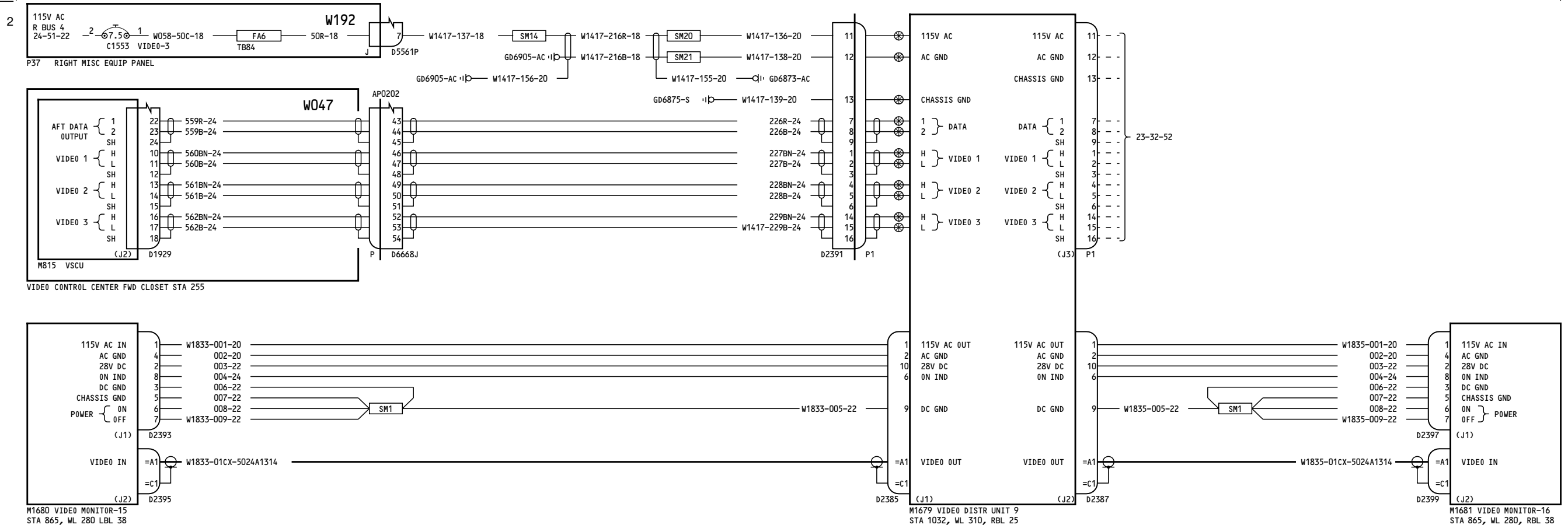

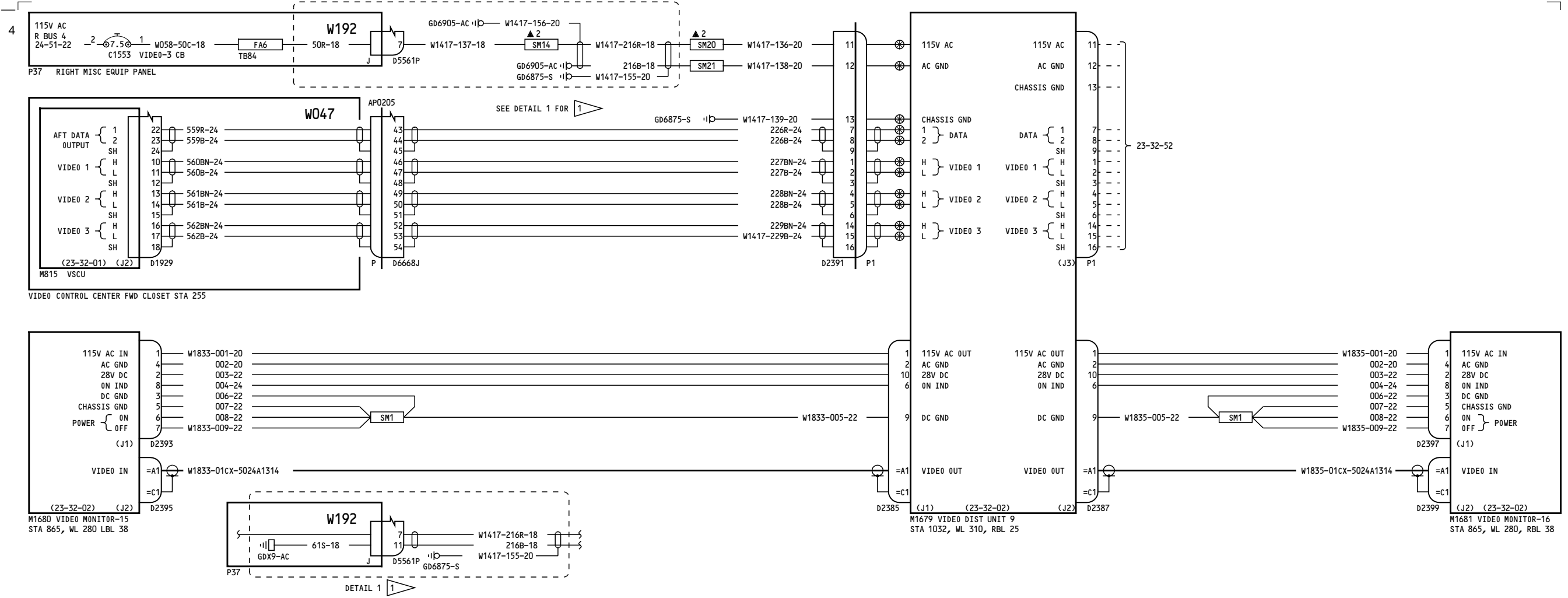

NOTES:
 1 VN223-VN230, VN671-VN675 (277-999, 279-999)

276-299	VIDEO ENTERTAINMENT SYSTEM-VIDEO 3 D280T132
---------	-----------------------------------------------------------

23-32-51

Page 2
 Jan 21/2005

23-32-51

Page 2
 Jan 21/2005

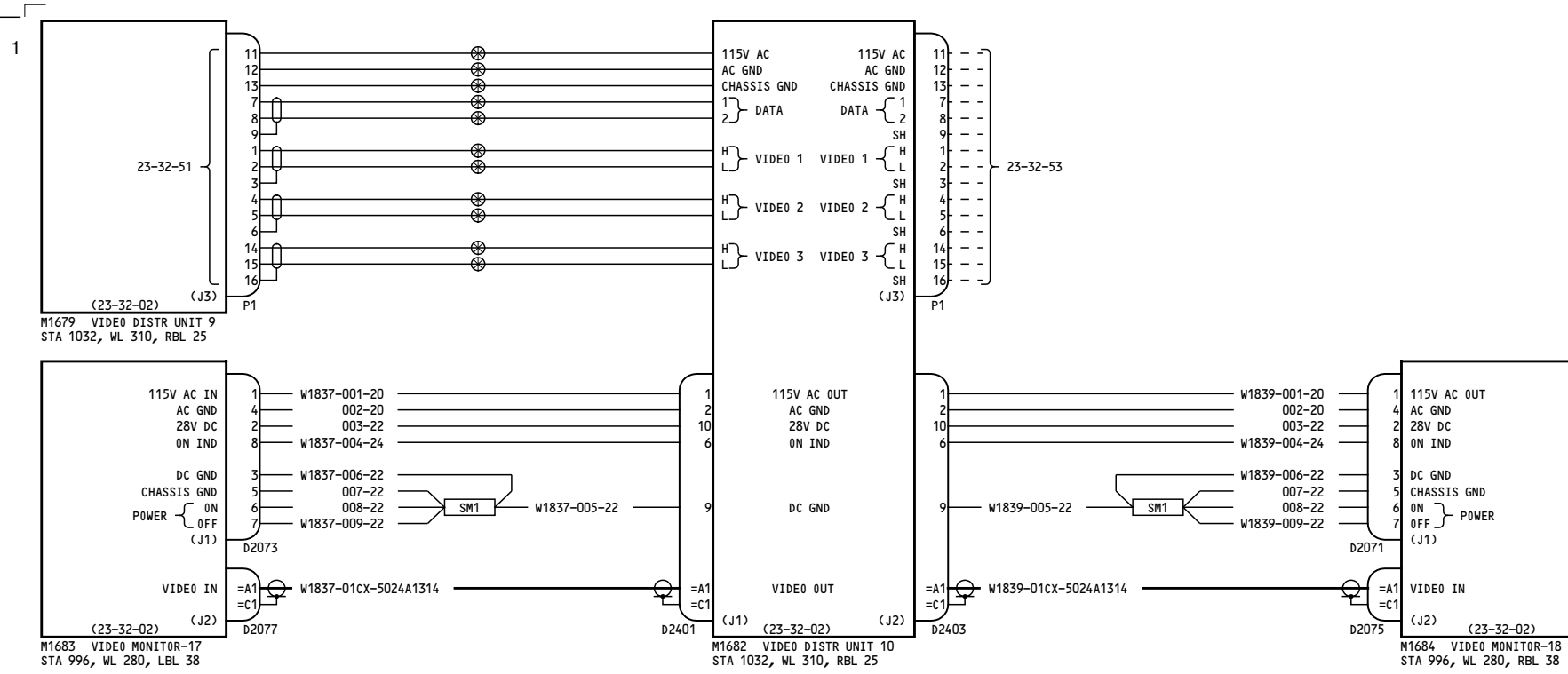

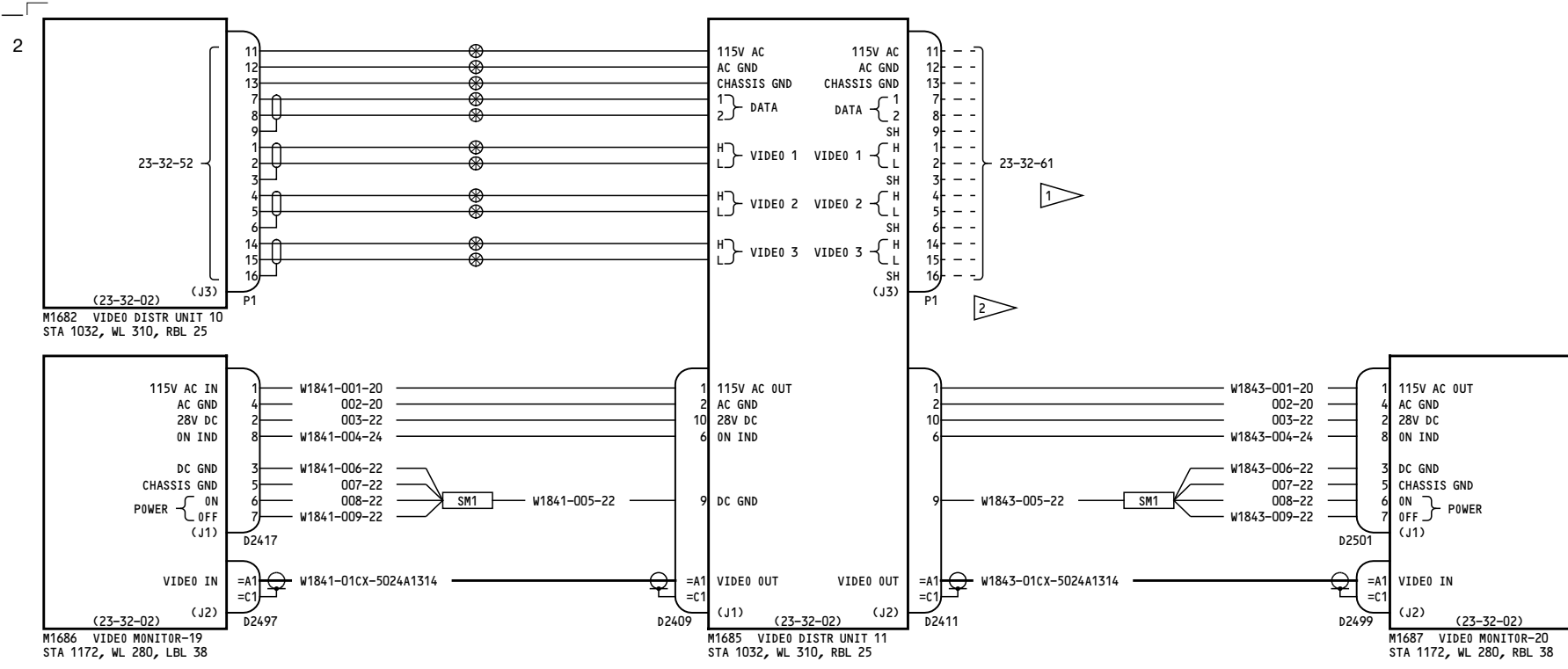

- NOTES:
- 1 23-32-54 FOR VN671-VN675 (279-999)
 - 2 D2413 FOR VN221-VN230 ONLY (275-999)

275-299	VIDEO ENTERTAINMENT SYSTEM- VIDEO 3
	D280T132

23-32-53

Page 1
Jan 21/2005

23-32-53

Page 1
Jan 21/2005

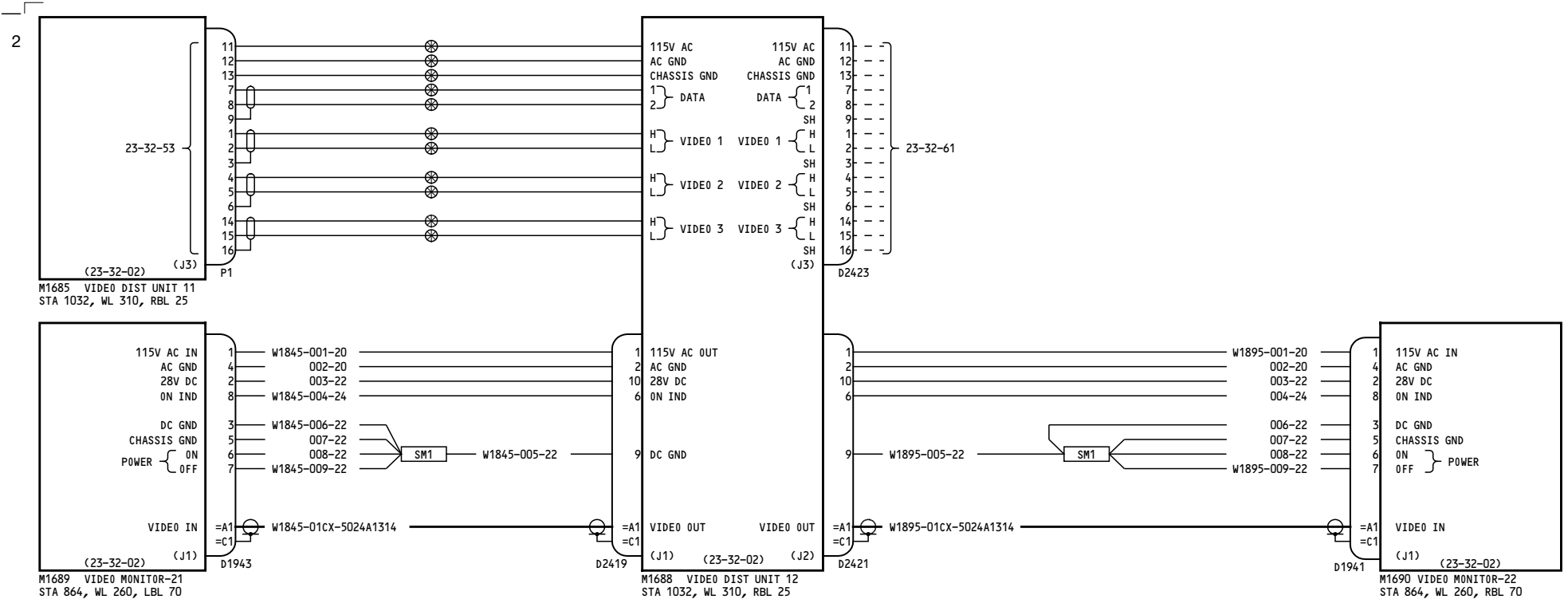

2

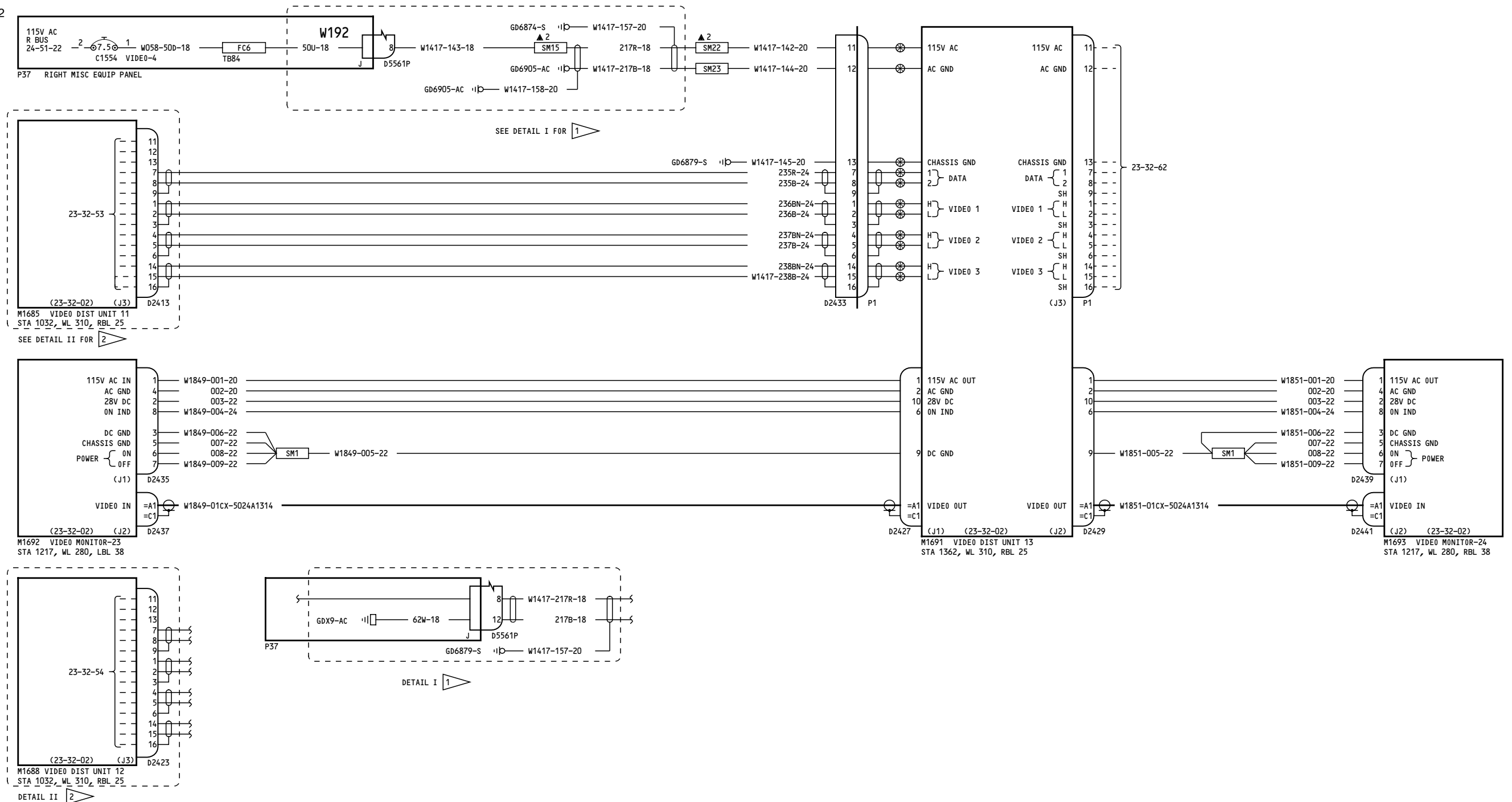

NOTES:
 1 VN223-VN230, VN671-VN675 (223-999, 279-999) 2 FOR VN671-VN675 (279-999)

275-299	VIDEO ENTERTAINMENT SYSTEM-VIDEO 4
	D280T132

23-32-61

Page 1
Jan 21/2005

23-32-61

Page 1
Jan 21/2005

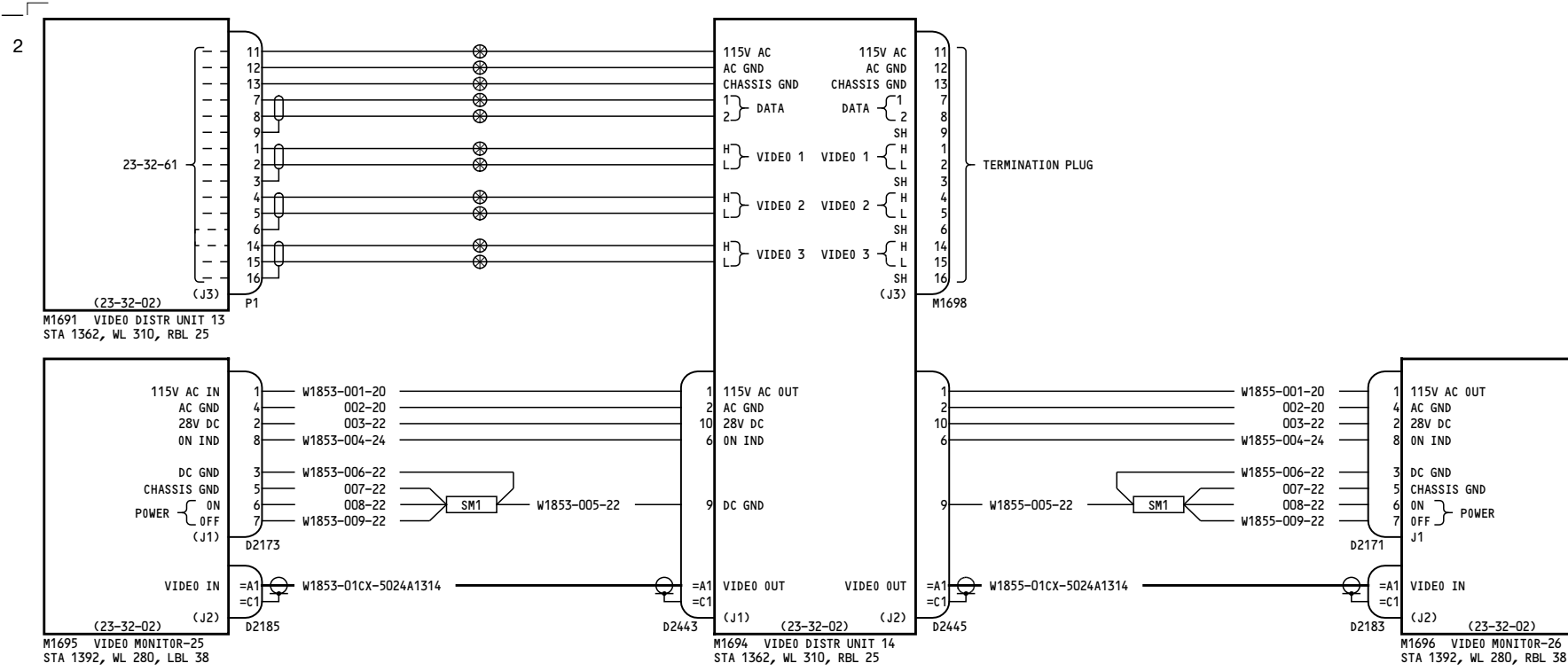

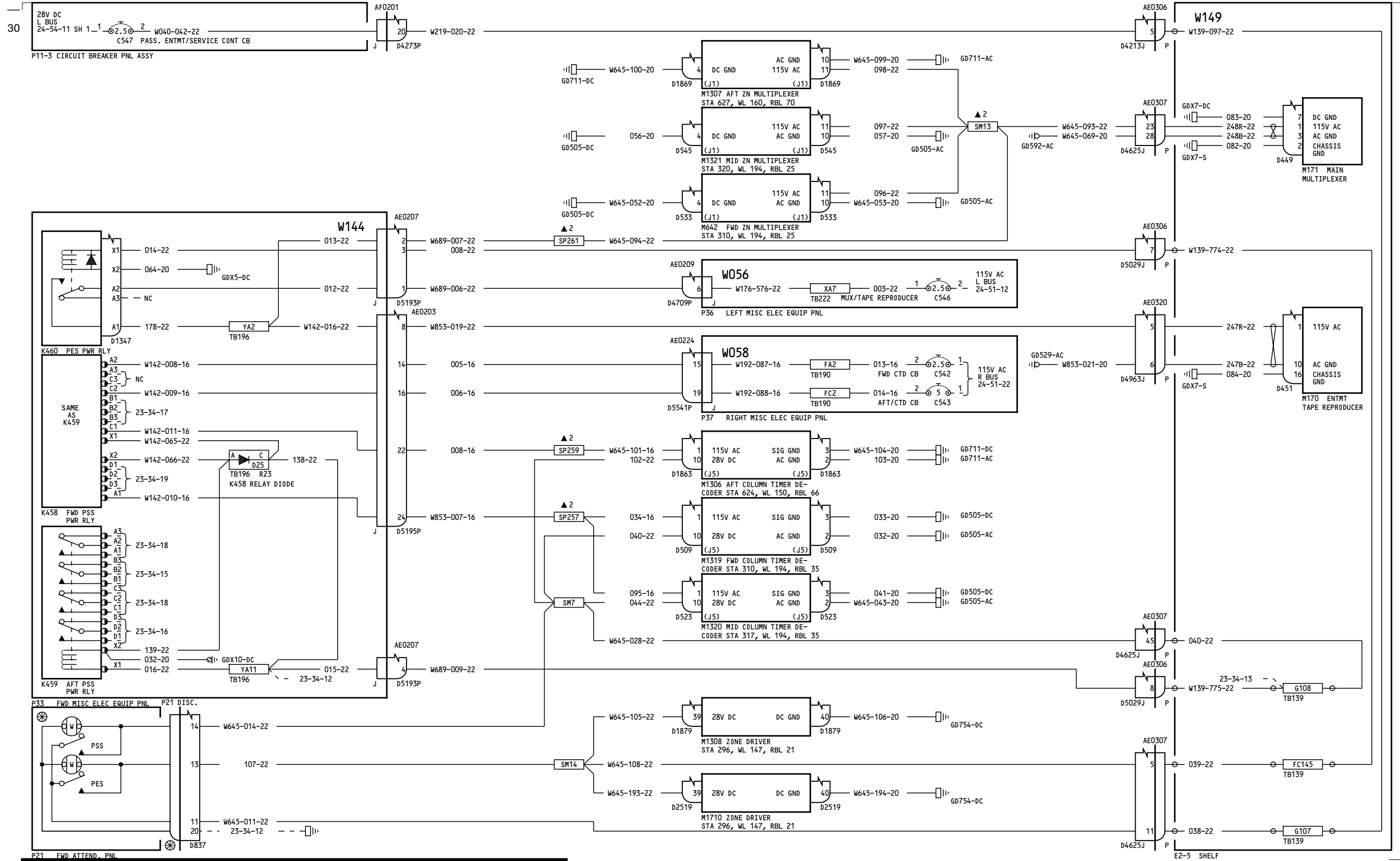

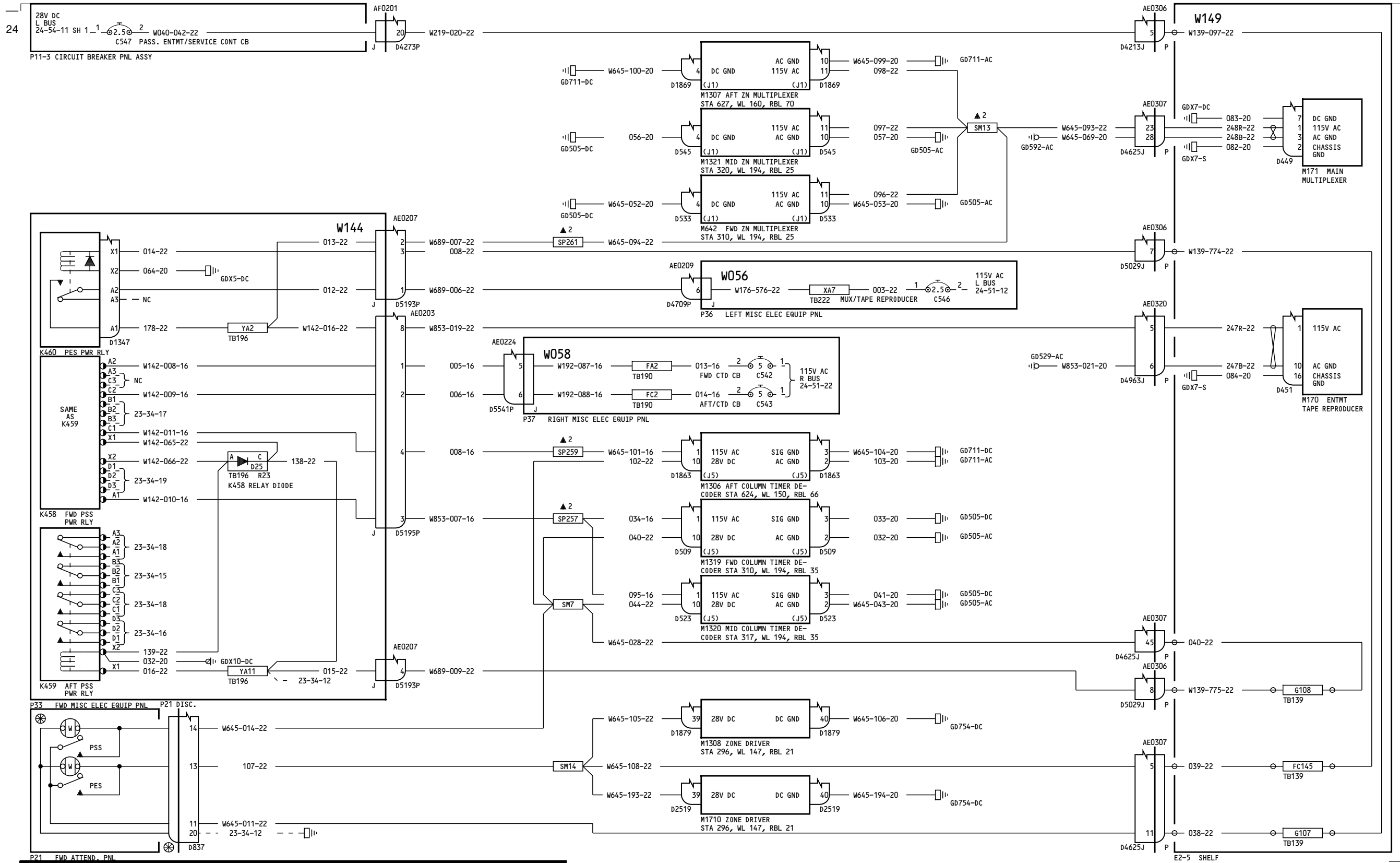

150-199

**PASSENGER ENTERTAINMENT
PASSENGER SERVICE**

D280T132

23-34-11

Page 2

Jan 21/2005

BOEING PROPRIETARY - Copyright © - Unpublished Work - See title page for details.

23-34-11

Page 2

Jan 21/2005

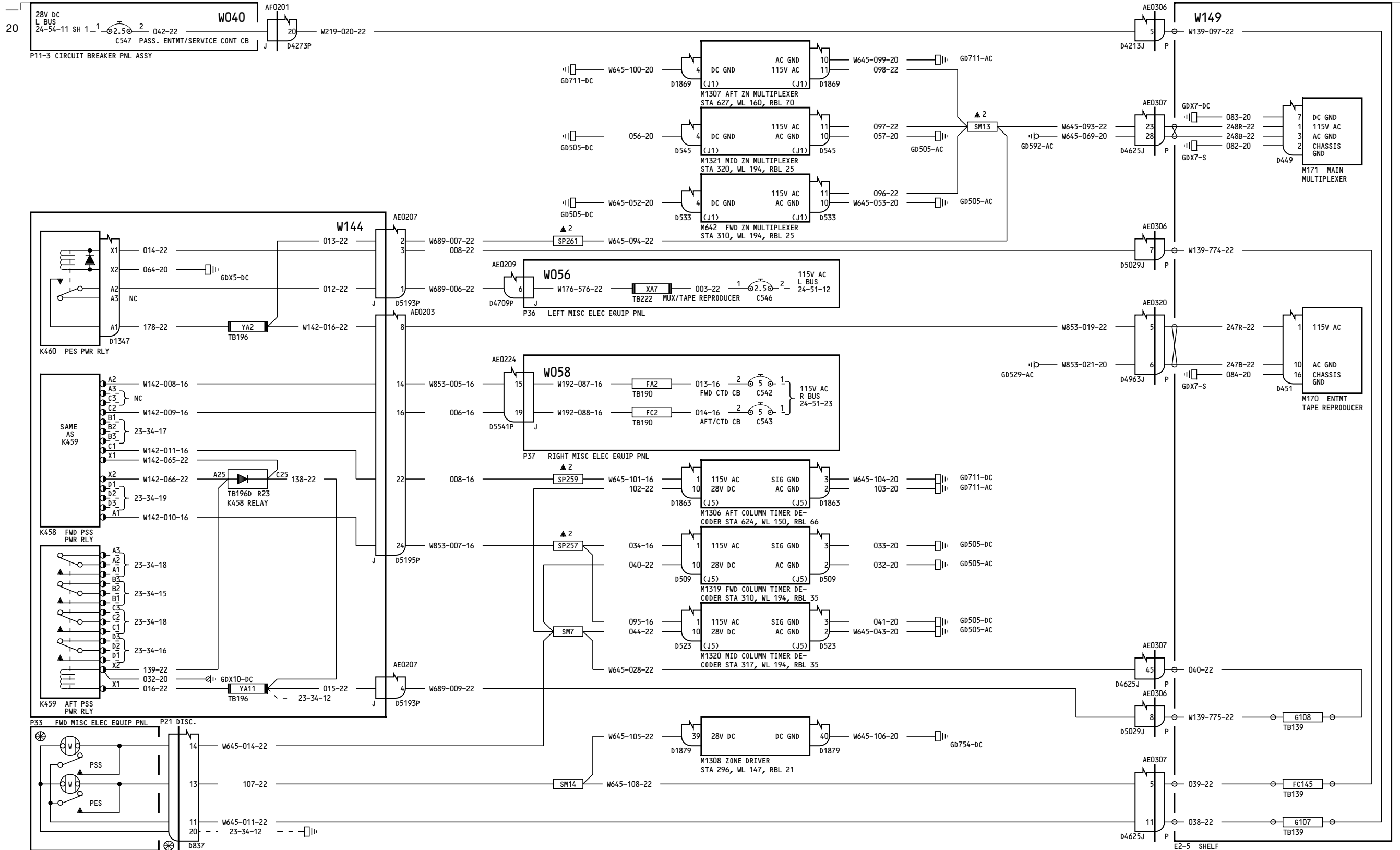

275-278

**PASSENGER ENTERTAINMENT
PASSENGER SERVICE**

23-34-11
Page 3
Jan 21/2005

D280T132

23-34-11
Page 3
Jan 21/2005

BOEING PROPRIETARY - Copyright © - Unpublished Work - See title page for details.

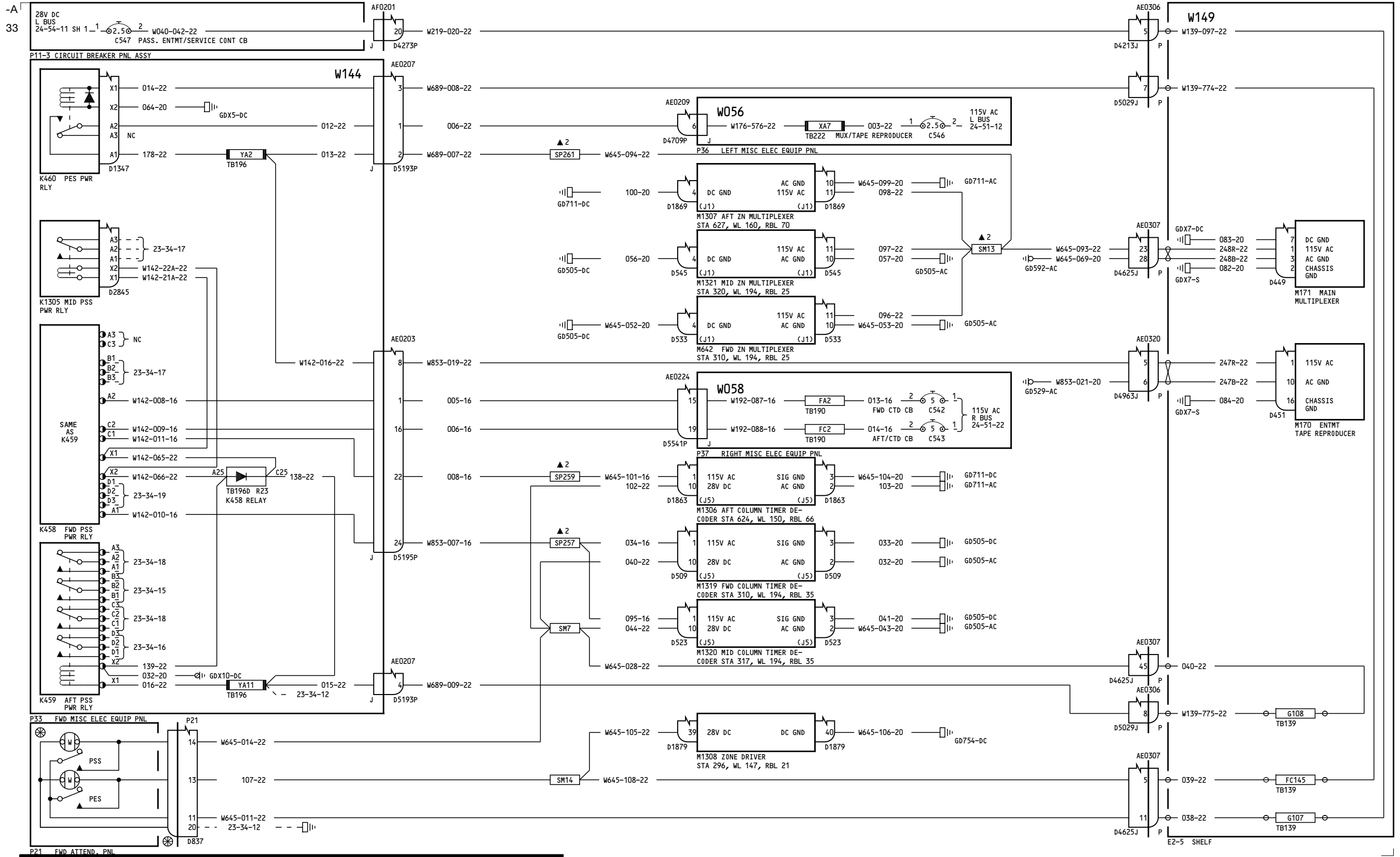

280-299

**PASSENGER ENTERTAINMENT
PASSENGER SERVICE**

23-34-11

Page 4

Jan 21/2005

D280T132

23-34-11

Page 4

Jan 21/2005

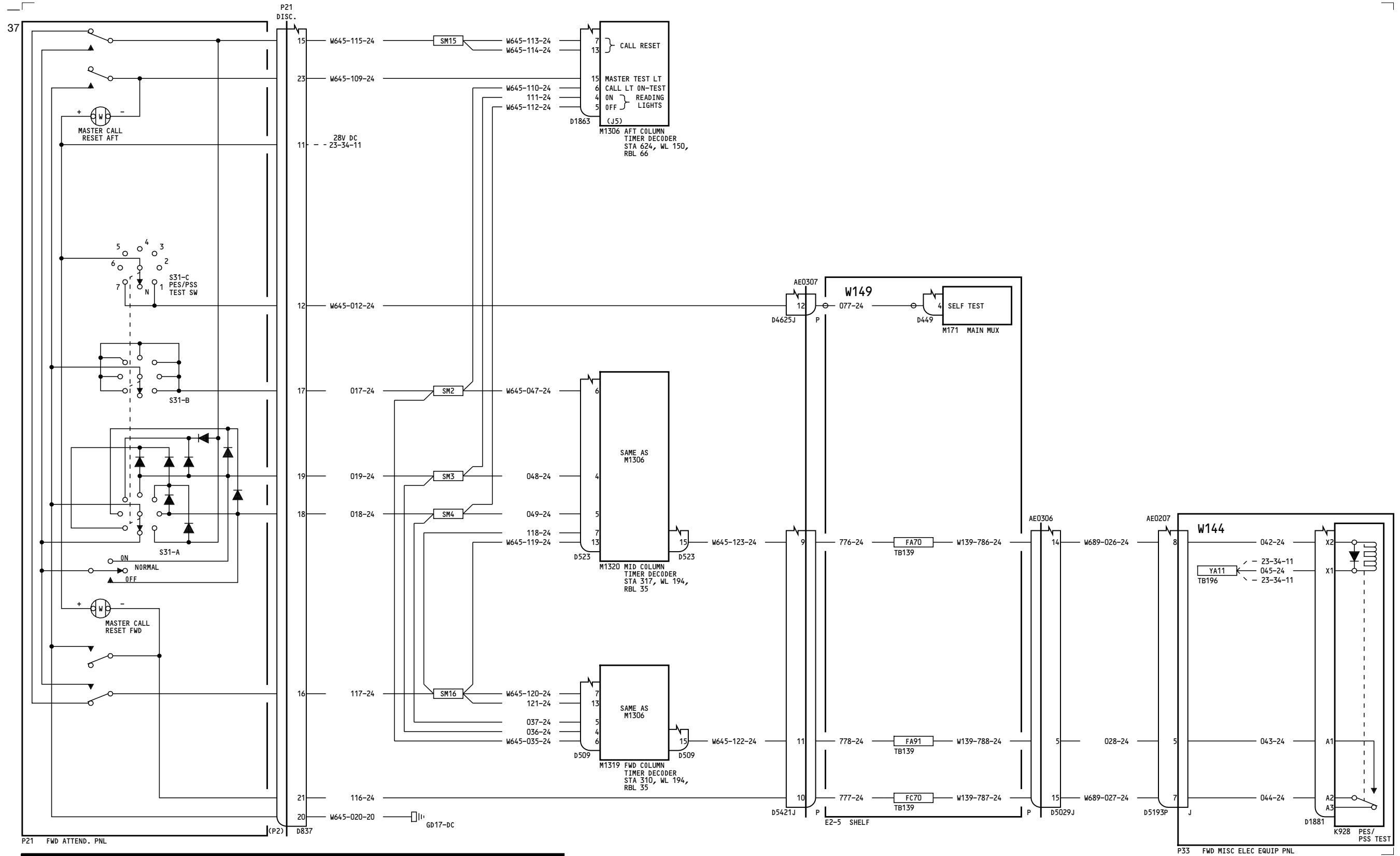

050-099

**PASSENGER ENTERTAINMENT
PASSENGER SERVICE**

D280T132

23-34-12

Page 1

Jan 21/2005

23-34-12

Page 1

Jan 21/2005

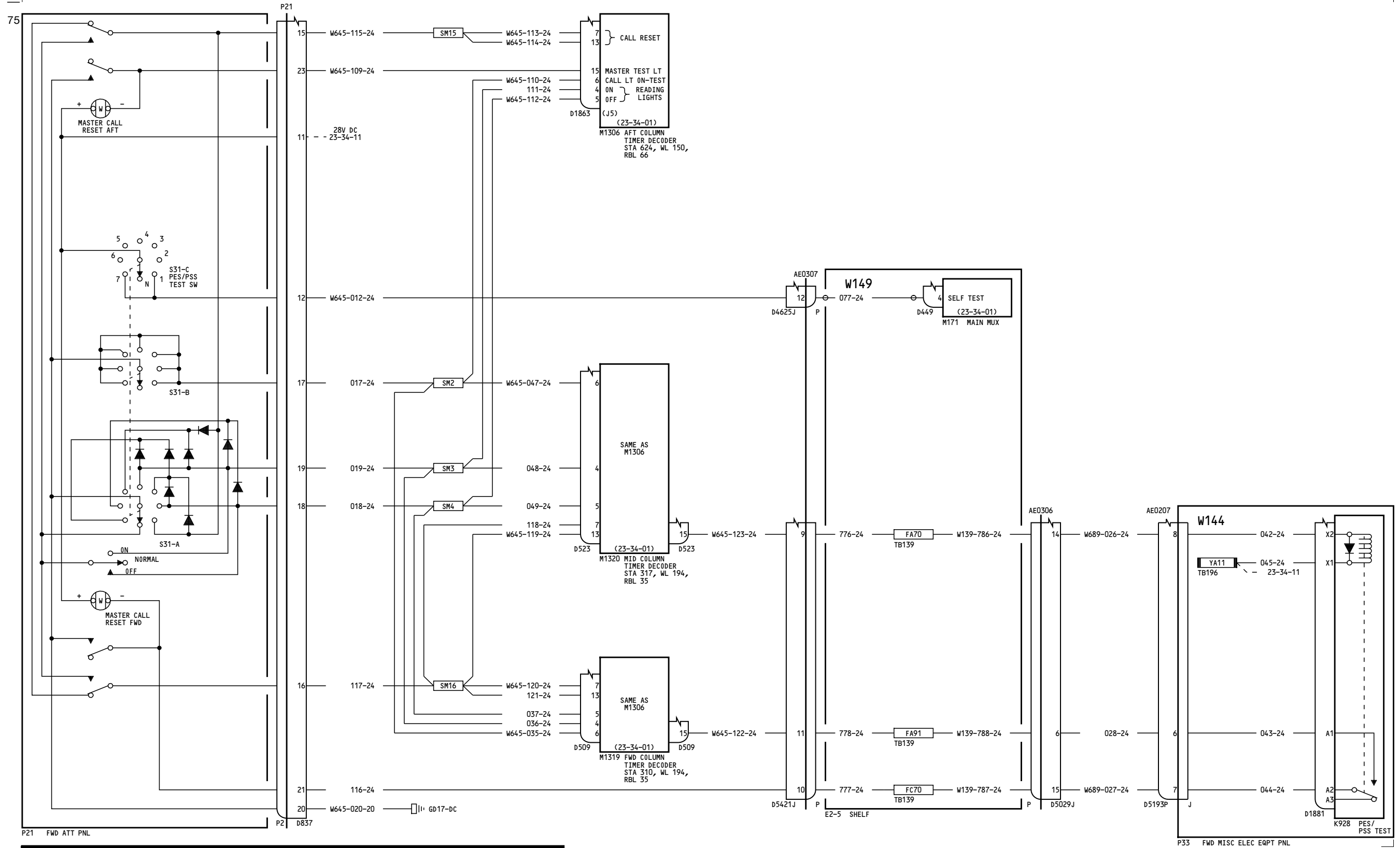

150-199, 275-299

**PASSENGER ENTERTAINMENT
PASSENGER SERVICE**

23-34-12

Page 2

D280T132

Jan 21/2005

23-34-12

Page 2

Jan 21/2005

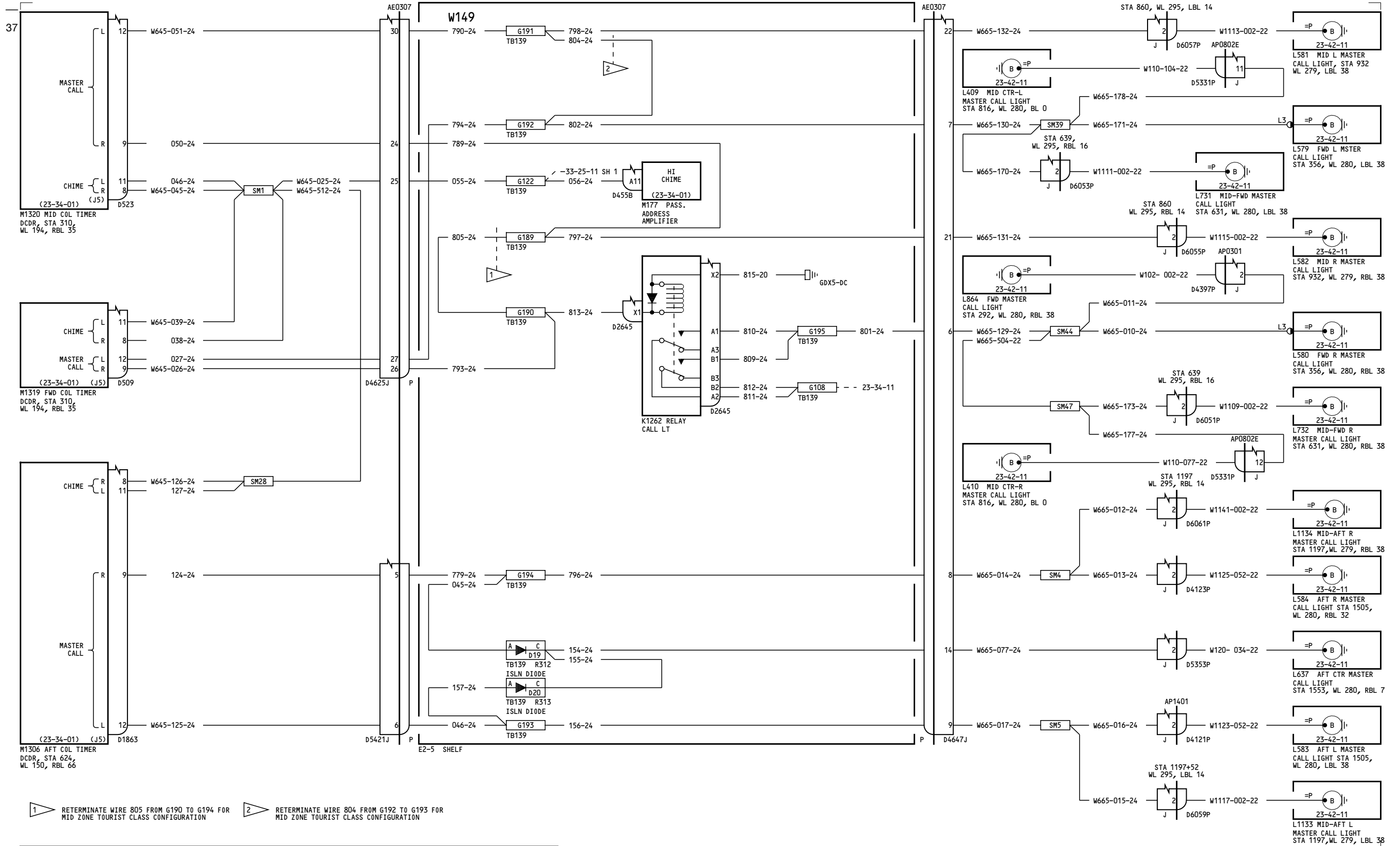

1 RETERMINATE WIRE 805 FROM G190 TO G194 FOR MID ZONE TOURIST CLASS CONFIGURATION
 2 RETERMINATE WIRE 804 FROM G192 TO G193 FOR MID ZONE TOURIST CLASS CONFIGURATION

050-099

PASSENGER ENTERTAINMENT PASSENGER SERVICE

23-34-13

Page 1

D280T132

Jan 21/2005

23-34-13

Page 1

Jan 21/2005

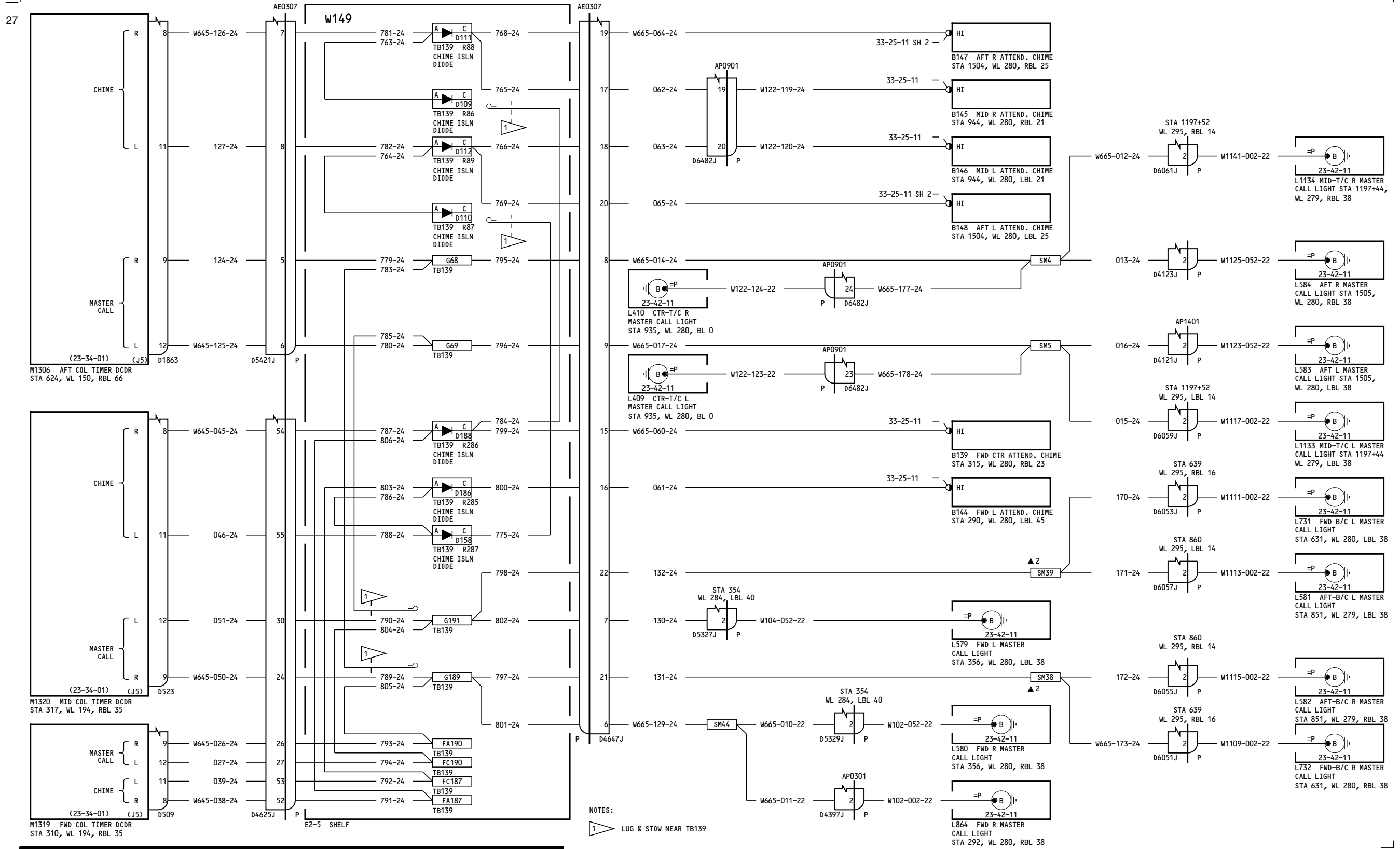

NOTES:
 1 LUG & STOW NEAR TB139

150

**PASSENGER ENTERTAINMENT
 PASSENGER SERVICE**

D280T132

23-34-13

Page 2
 Jan 21/2005

23-34-13

Page 2
 Jan 21/2005

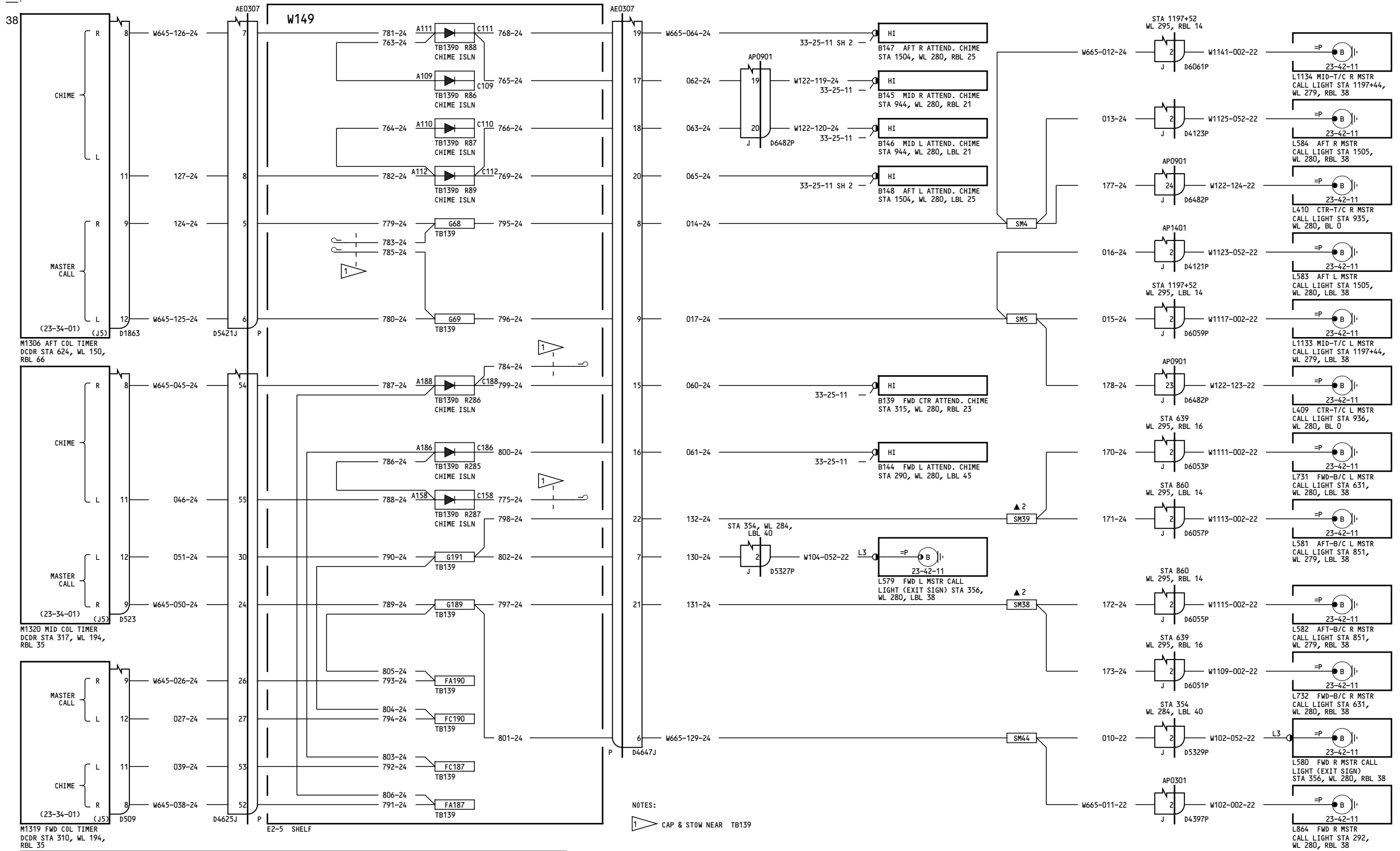

151-154, 156

PASSENGER ENTERTAINMENT PASSENGER SERVICE

23-34-13

Page 3

D280T132

Jan 21/2005

23-34-13

Page 3

Jan 21/2005

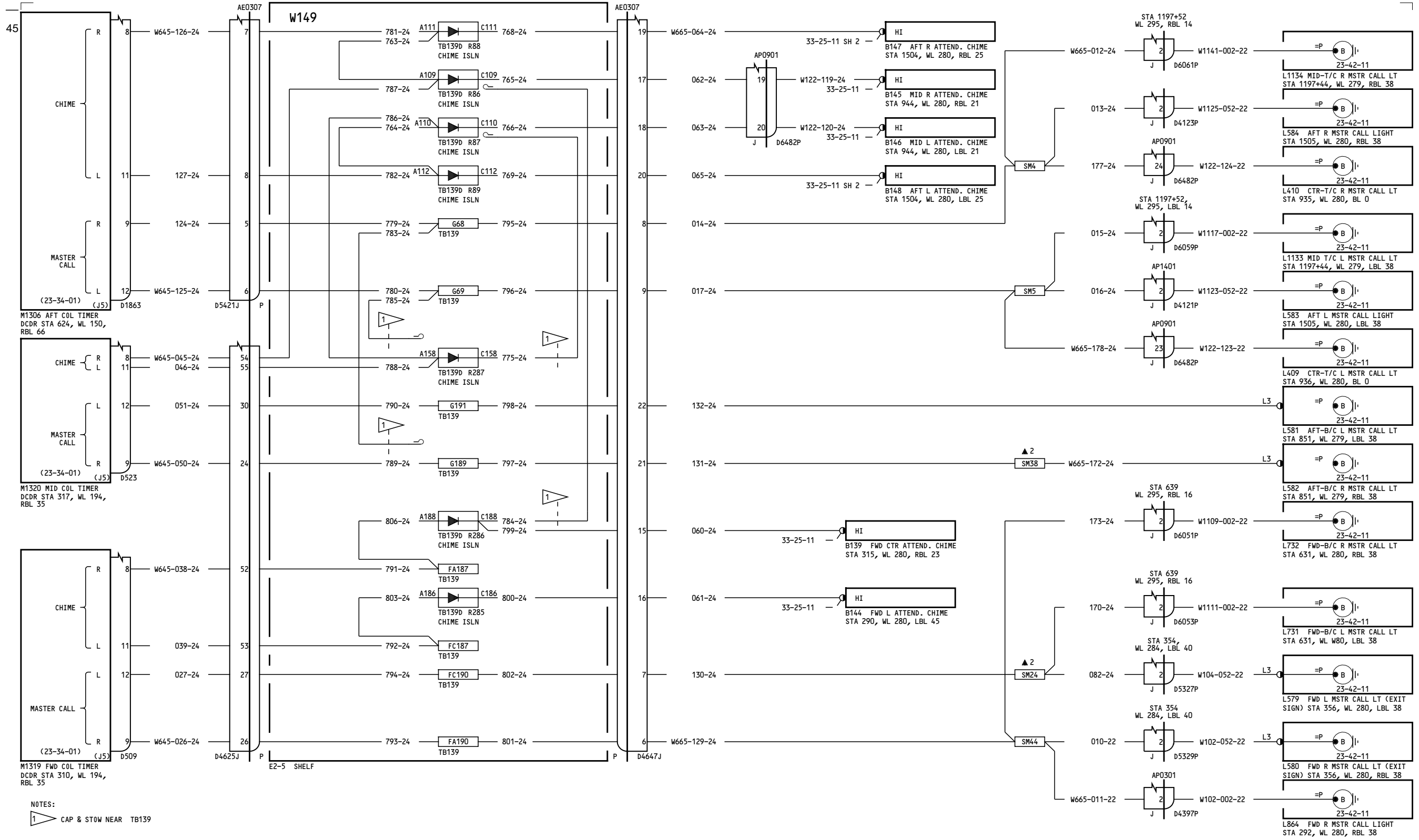

NOTES:
 CAP & STOW NEAR TB139

155

**PASSENGER ENTERTAINMENT
 PASSENGER SERVICE**

D280T132

23-34-13

Page 4

Jan 21/2005

23-34-13

Page 4

Jan 21/2005

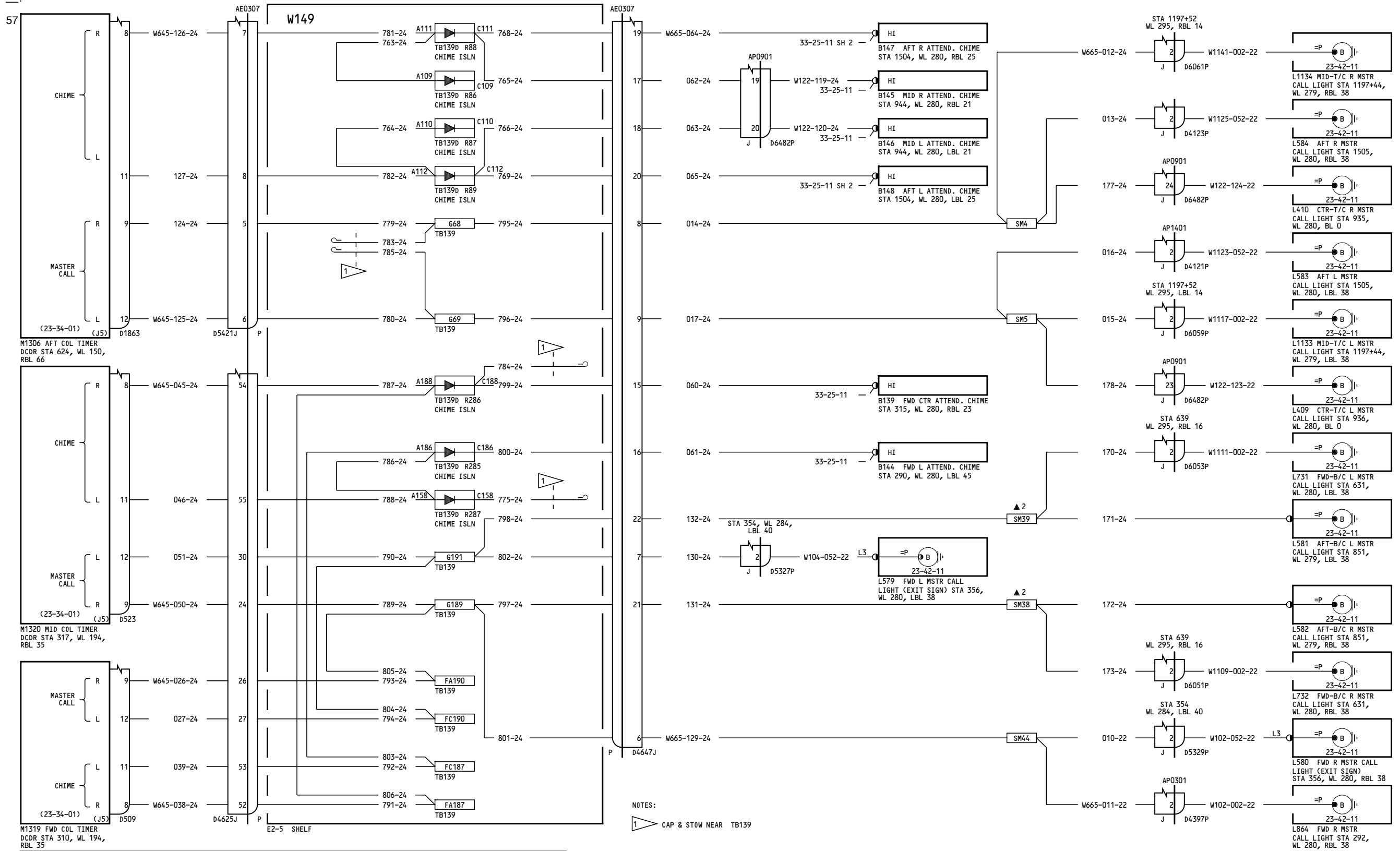

NOTES:
1 CAP & STOW NEAR TB139

157

**PASSENGER ENTERTAINMENT
PASSENGER SERVICE**

23-34-13

Page 5

Jan 21/2005

D280T132

23-34-13

Page 5

Jan 21/2005

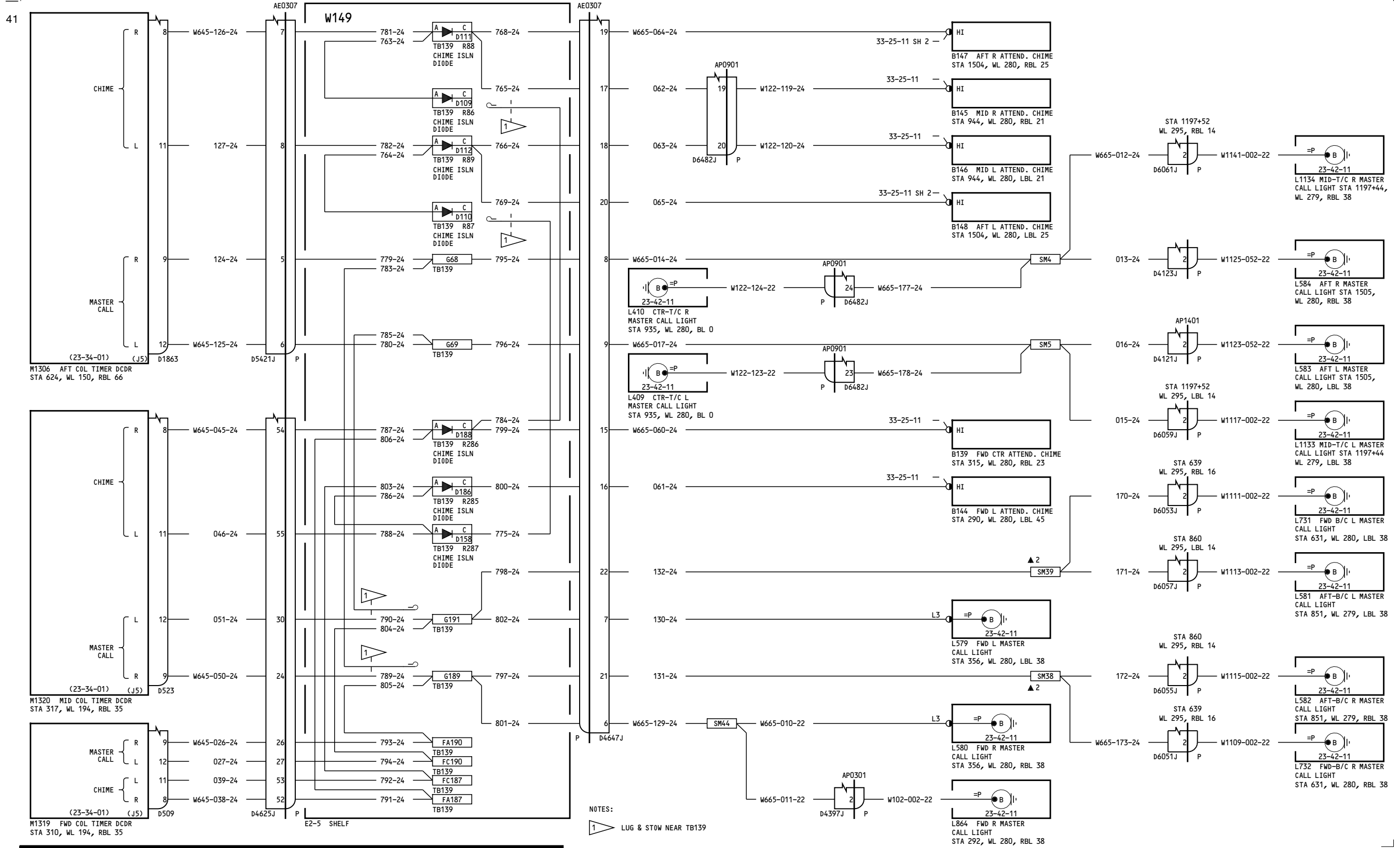

NOTES:
 LUG & STOP NEAR TB139

162-199

PASSENGER ENTERTAINMENT PASSENGER SERVICE

23-34-13

Page 6

Jan 21/2005

D280T132

23-34-13

Page 6

Jan 21/2005

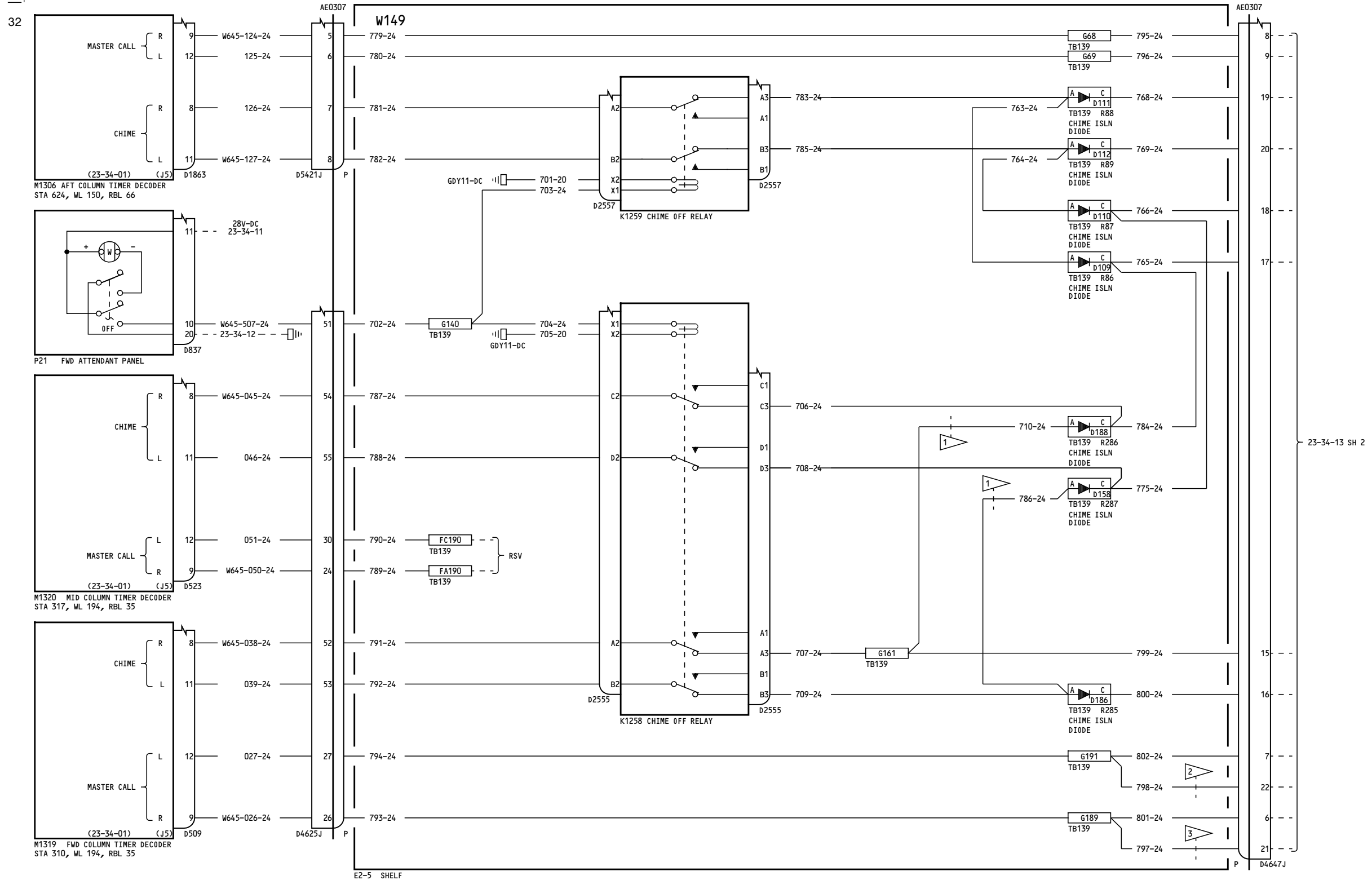

NOTES:
 1 CAP & STOW NEAR TB139 FOR ALT 2 CLASS CONF.

2 RETERMINATE WIRE 798 TO TB139 FC190 FOR ALT 2 CLASS CONF.

3 RETERMINATE WIRE 797 TO TB139 FA190 FOR ALT 2 CLASS CONF.

275-276

PASSENGER ENTERTAINMENT PASSENGER SERVICE

23-34-13

Page 7
Sheet 1
Jan 21/2005

D280T132

23-34-13

Page 7
Sheet 1
Jan 21/2005

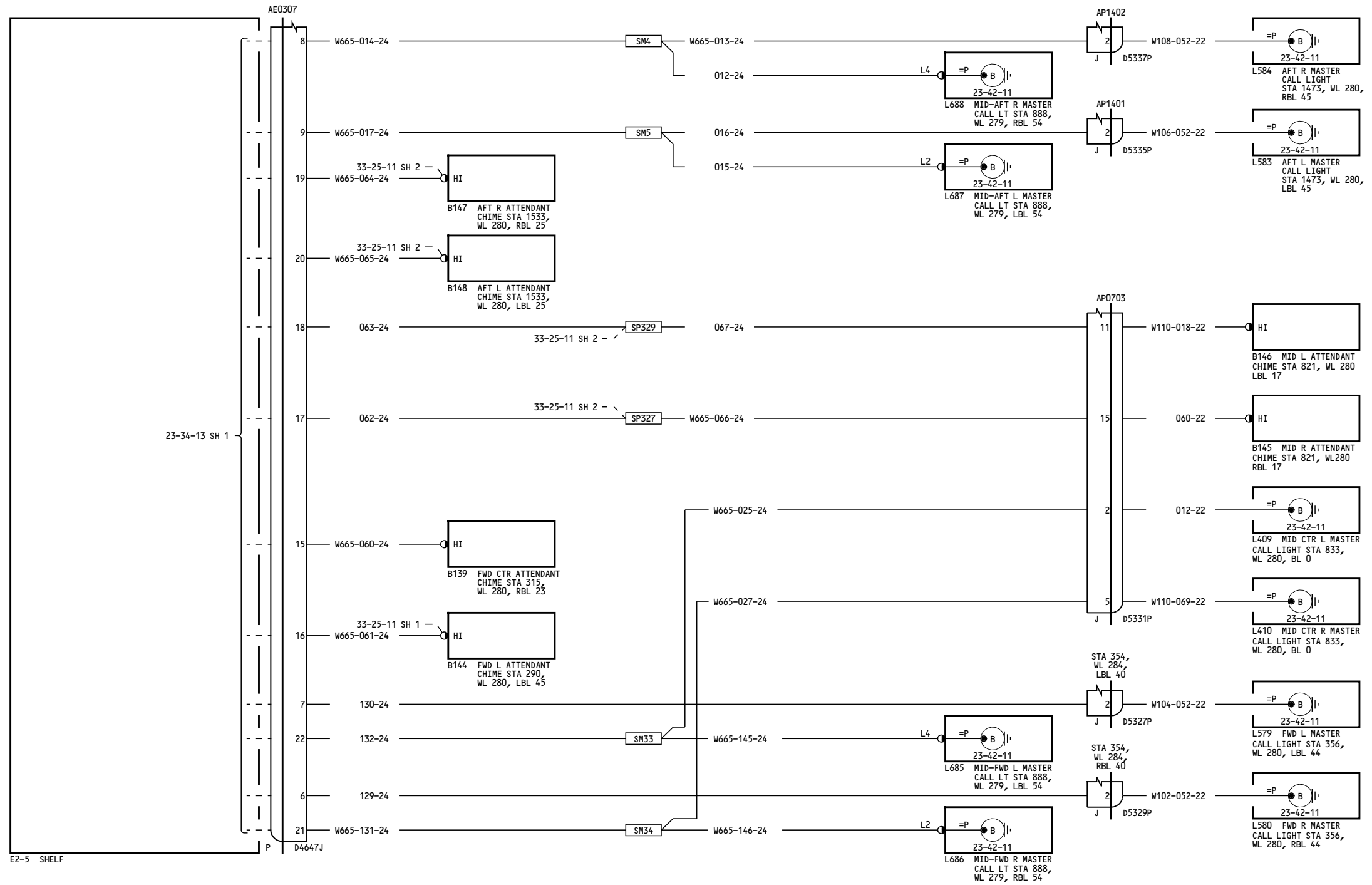

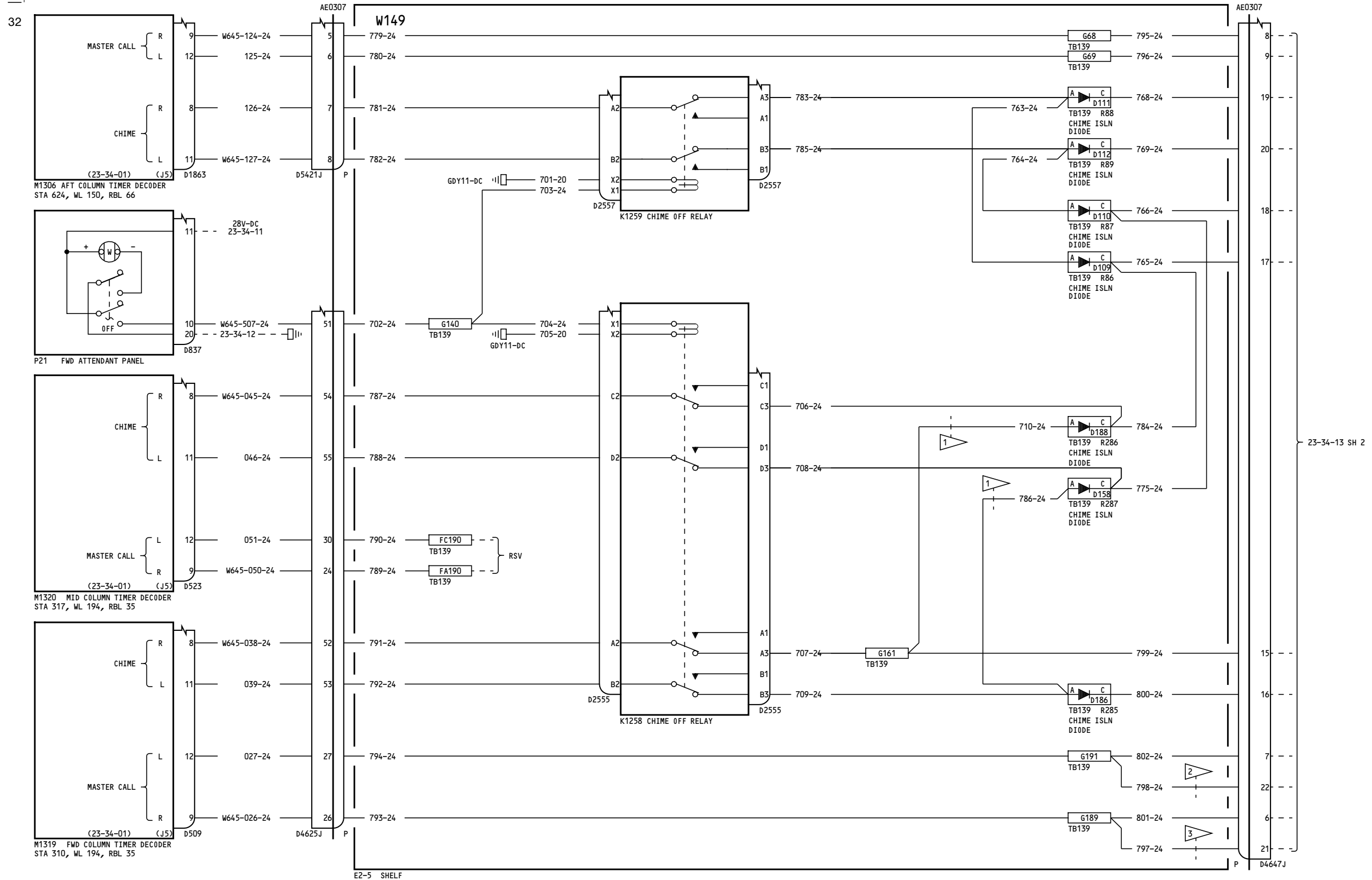

NOTES:
 1 CAP & STOW NEAR TB139 FOR ALT 2 CLASS CONF.

2 RETERMINATE WIRE 798 TO TB139 FC190 FOR ALT 2 CLASS CONF.

3 RETERMINATE WIRE 797 TO TB139 FA190 FOR ALT 2 CLASS CONF.

275-276

**PASSENGER ENTERTAINMENT
 PASSENGER SERVICE**

23-34-13

Page 7.1
 Sheet 1
 Jan 21/2005

D280T132

23-34-13

Page 7.1
 Sheet 1
 Jan 21/2005

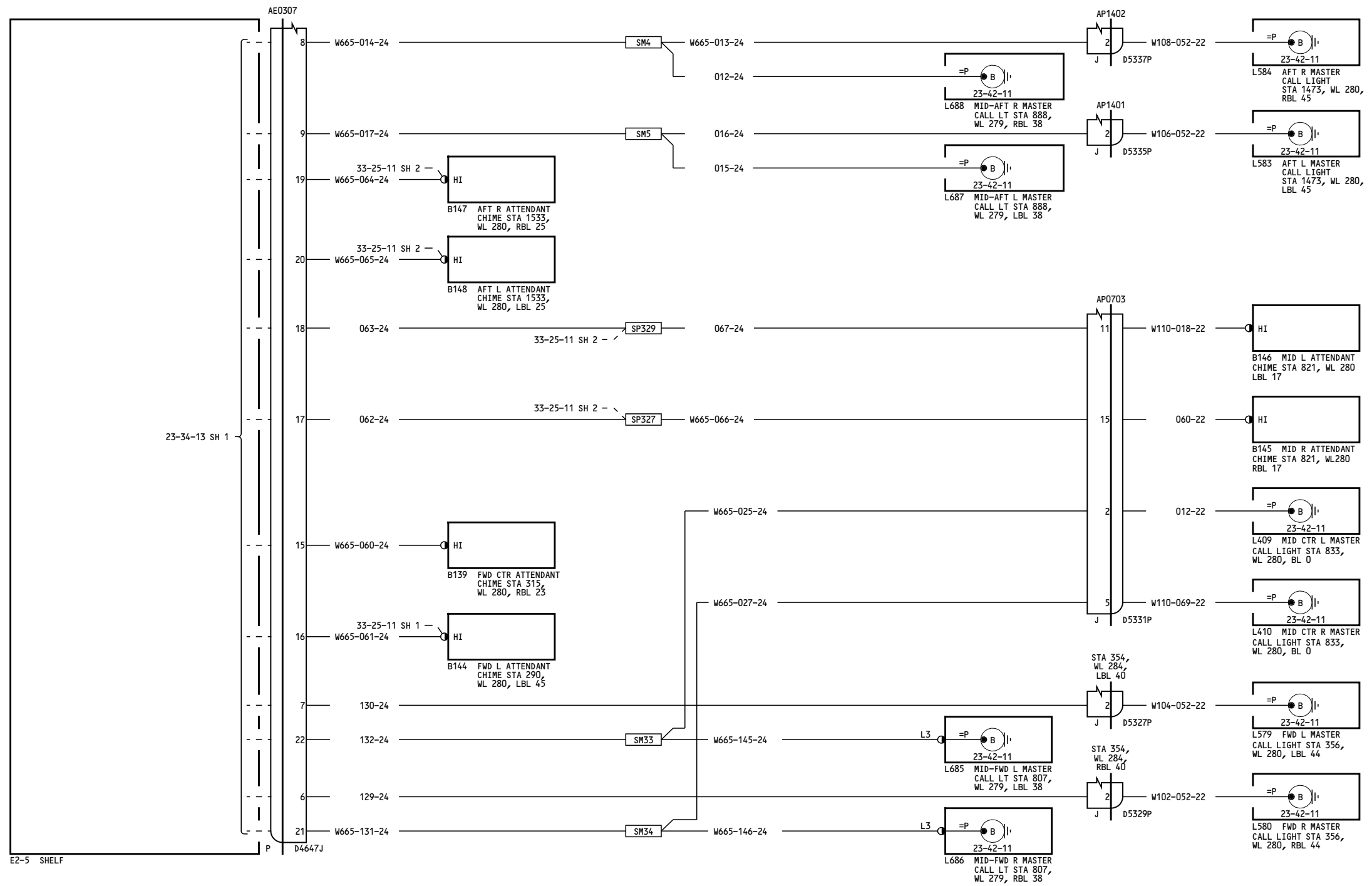

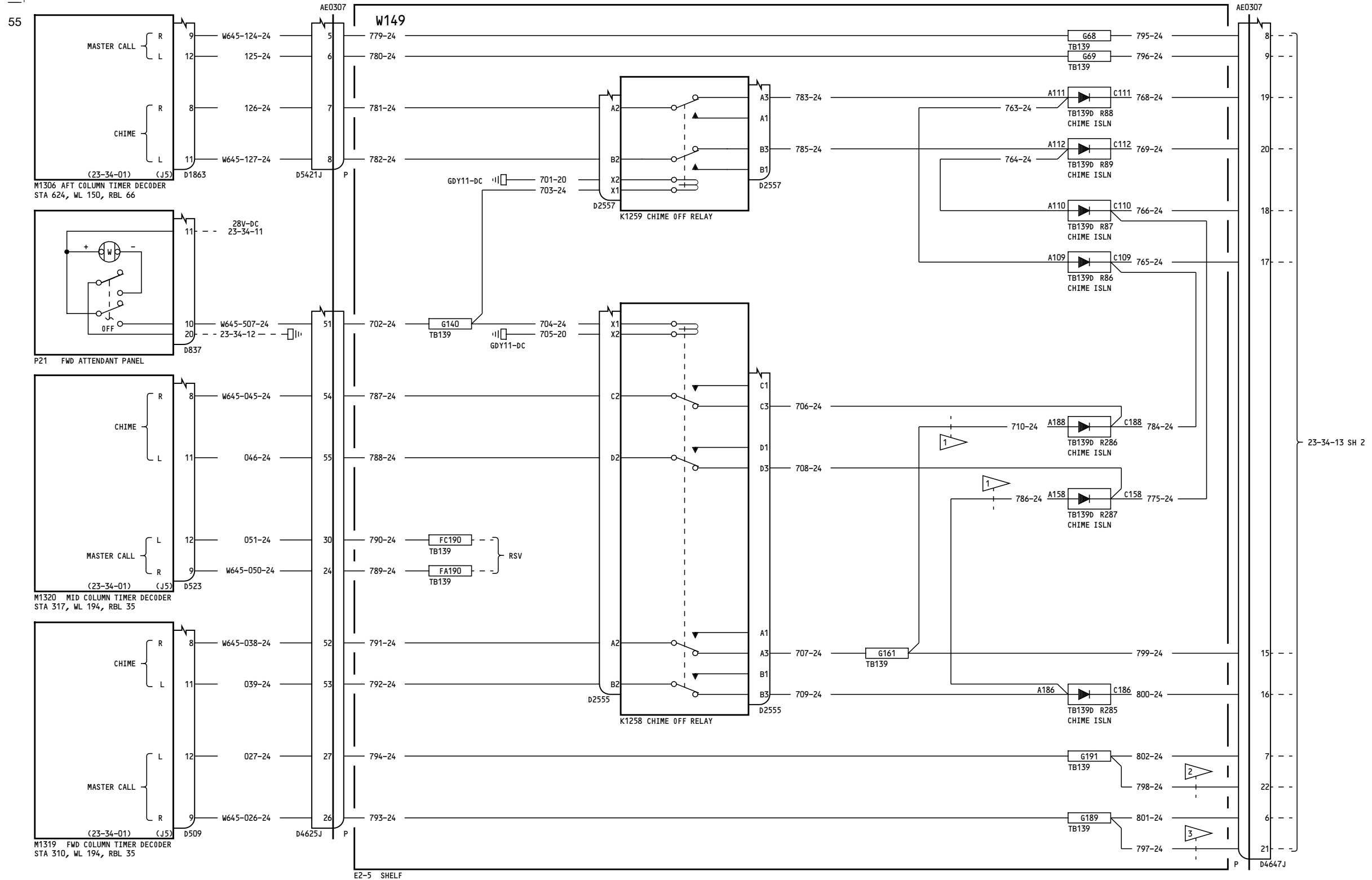

NOTES:
 1 CAP & STOW NEAR TB139 FOR ALT 2 CLASS CONF.

2 RETERMINATE WIRE 798 TO TB139 FC190 FOR ALT 2 CLASS CONF.

3 RETERMINATE WIRE 797 TO TB139 FA190 FOR ALT 2 CLASS CONF.

277-278

PASSENGER ENTERTAINMENT PASSENGER SERVICE

23-34-13

Page 8
Sheet 1
Jan 21/2005

D280T132

23-34-13

Page 8
Sheet 1
Jan 21/2005

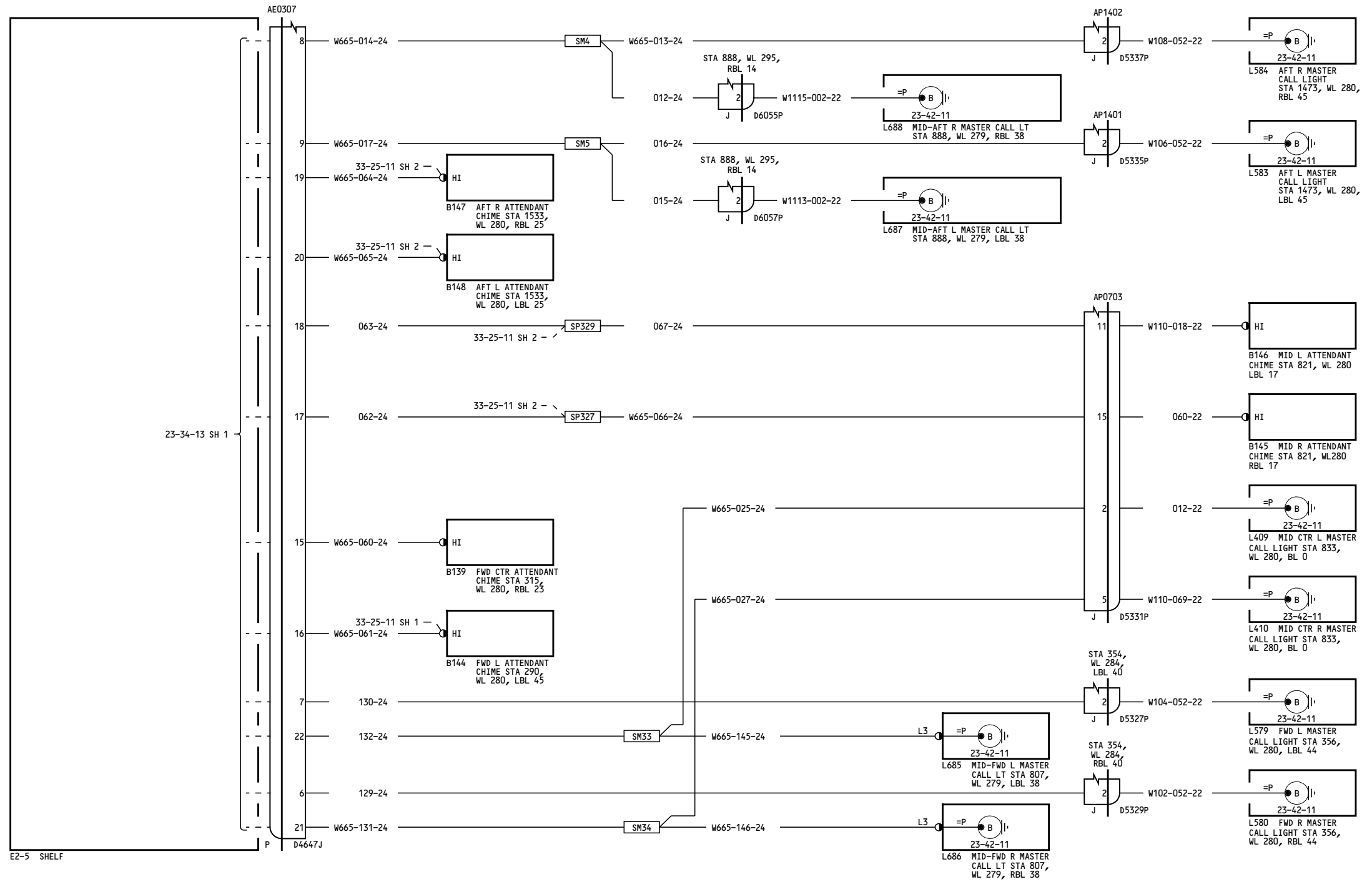

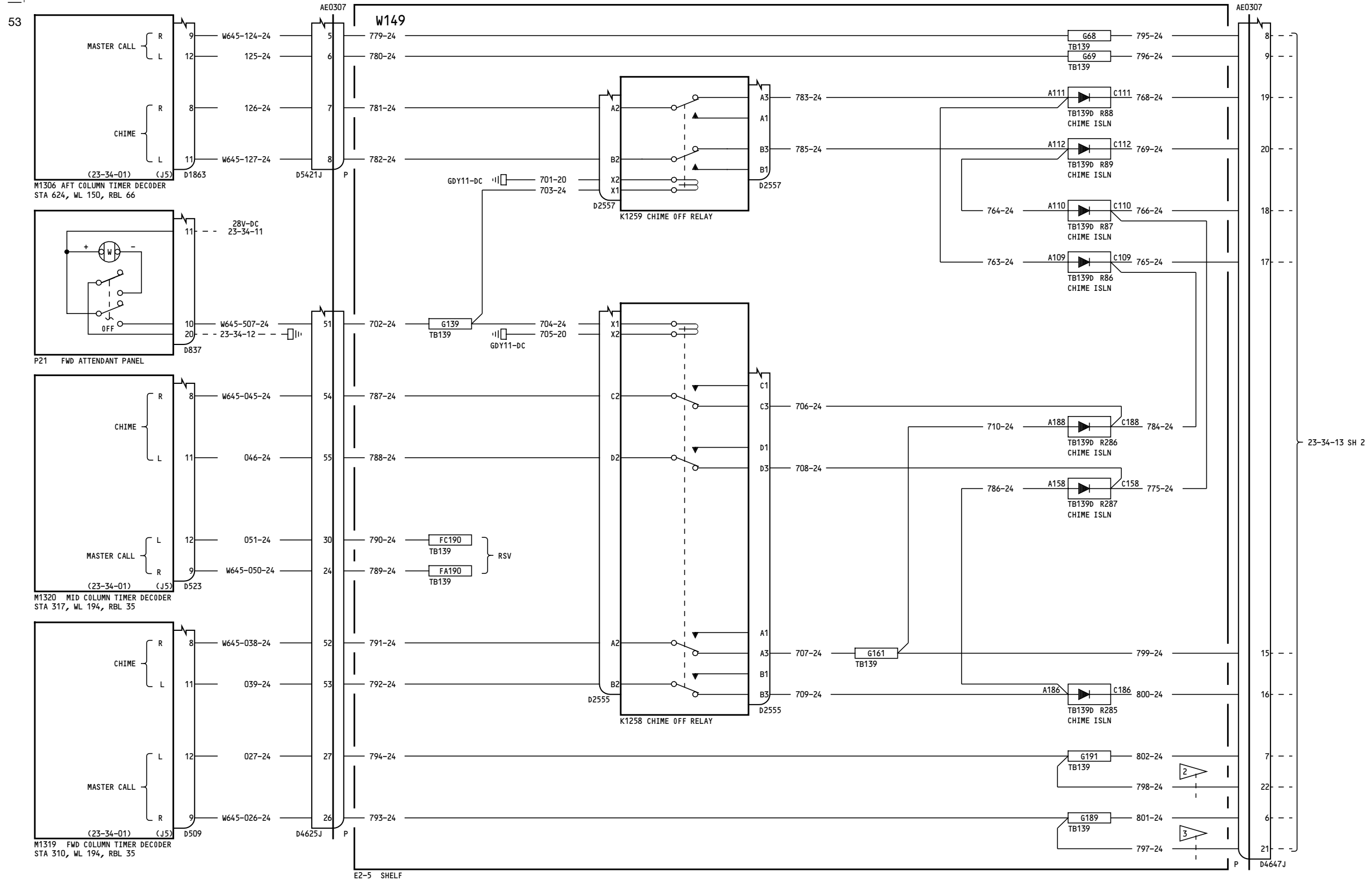

NOTES:
 1 RETERMINATE WIRE 710 TO R286 FOR ALTERNATE 1 CLASS CONFIGURATION

2 RETERMINATE WIRE 798 TO TB139 FC190 FOR ALTERNATE 2 CLASS CONFIGURATION.

3 RETERMINATE WIRE 797 TO TB139 FA190 FOR ALTERNATE 2 CLASS CONFIGURATION.

280-299

PASSENGER ENTERTAINMENT PASSENGER SERVICE

23-34-13

Page 9
Sheet 1
Jan 21/2005

D280T132

23-34-13

Page 9
Sheet 1
Jan 21/2005

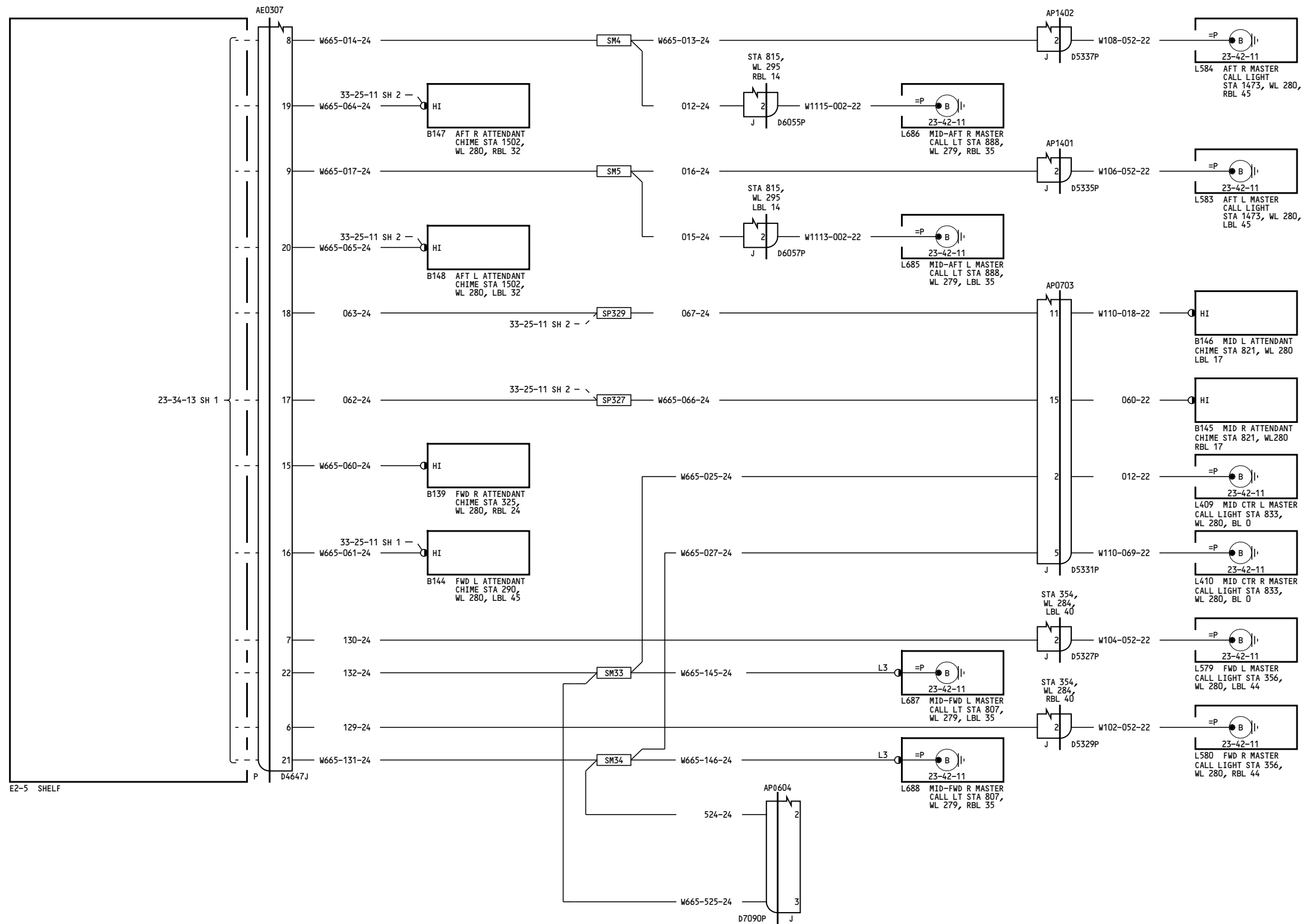

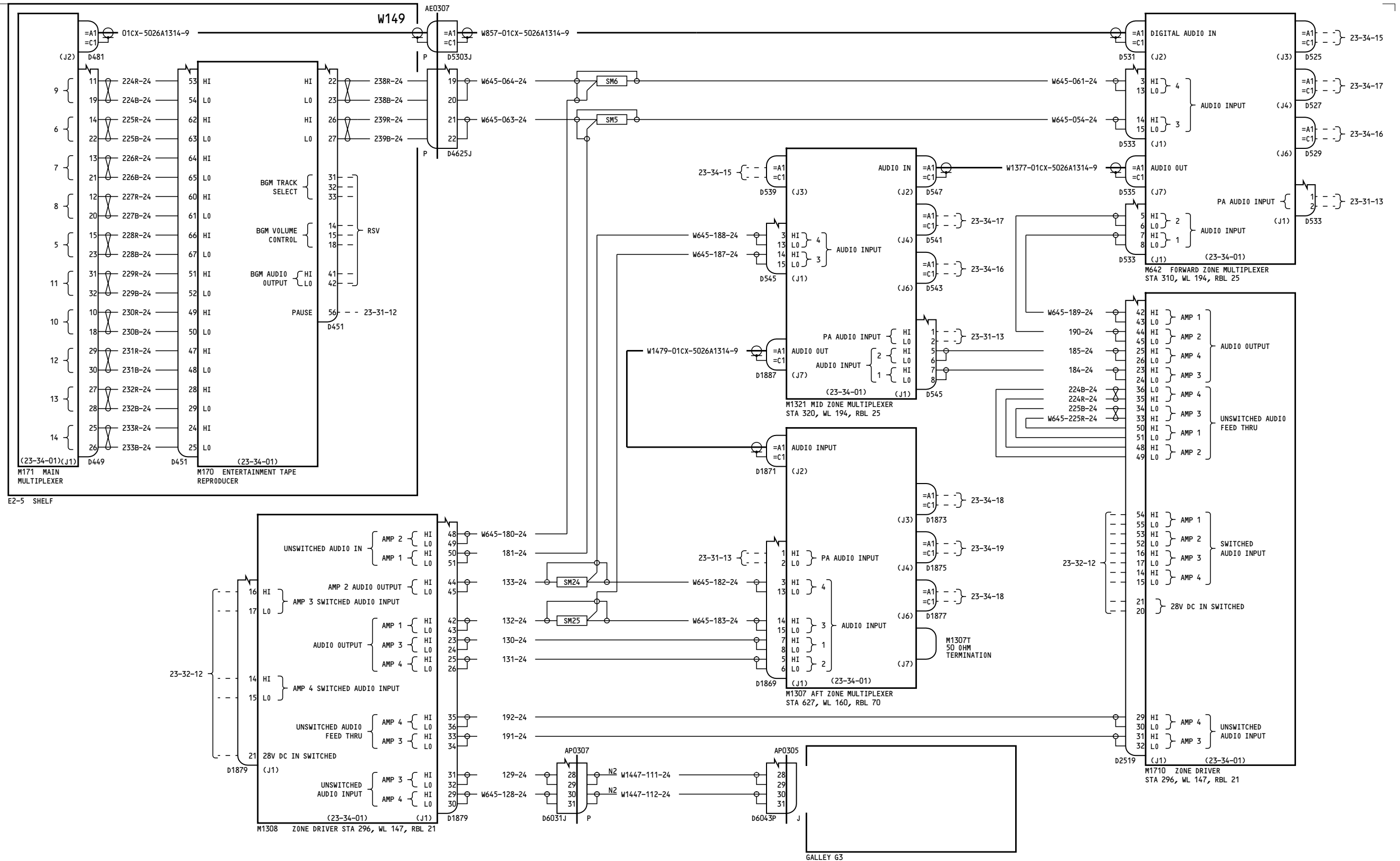

050-051

PASSENGER ENTERTAINMENT PASSENGER SERVICE

23-34-14

Page 1A

Jan 21/2005

D280T132

Incorporates MTO 230540

23-34-14

Page 1A

Jan 21/2005

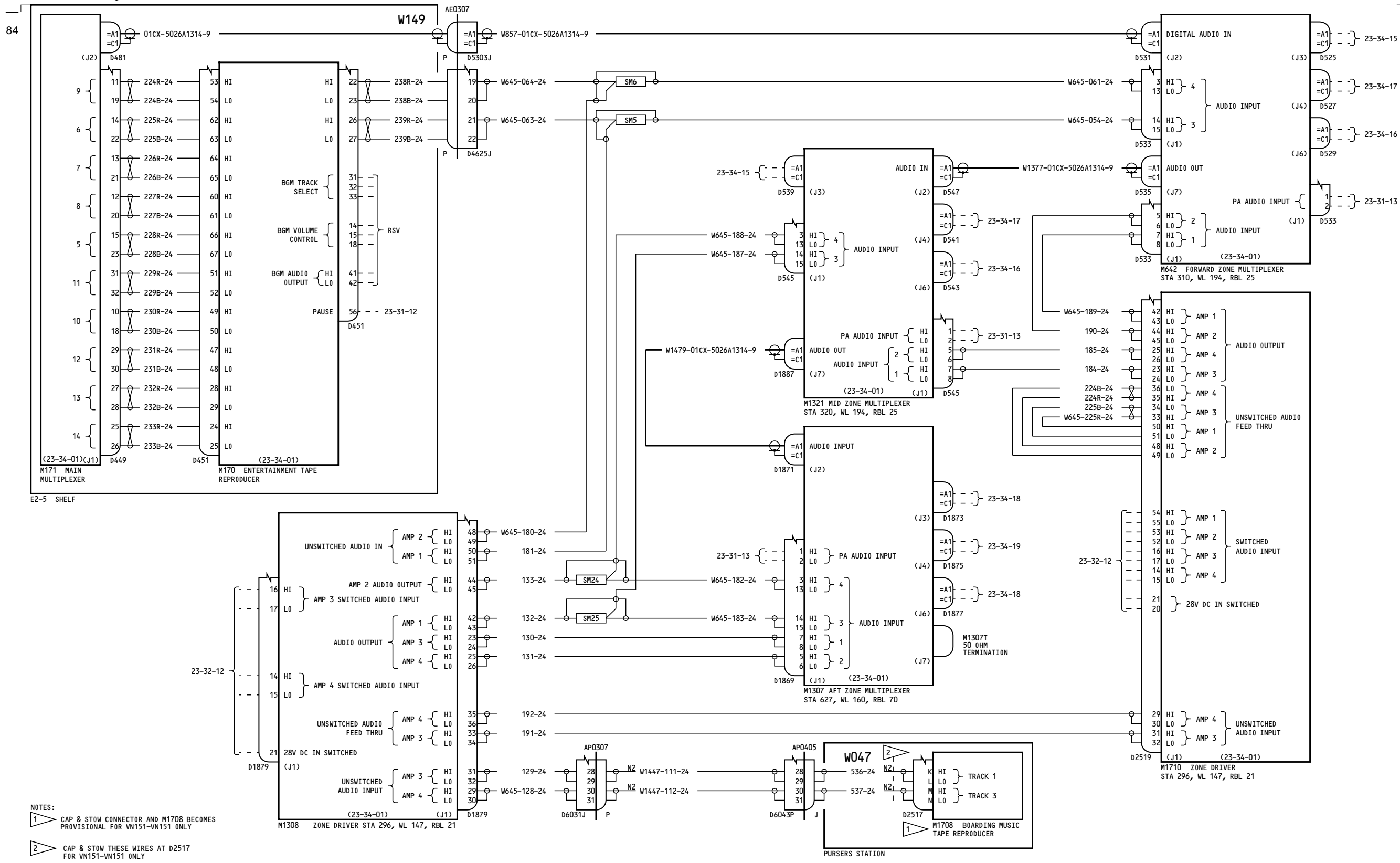

NOTES:
 1 CAP & STOW CONNECTOR AND M1708 BECOMES PROVISIONAL FOR VN151-VN151 ONLY
 2 CAP & STOW THESE WIRES AT D2517 FOR VN151-VN151 ONLY

150-154

PASSENGER ENTERTAINMENT
 PASSENGER SERVICE

D280T132

23-34-14

Page 2A

Jan 21/2005

Incorporates
 TD 3302

23-34-14

Page 2A

Jan 21/2005

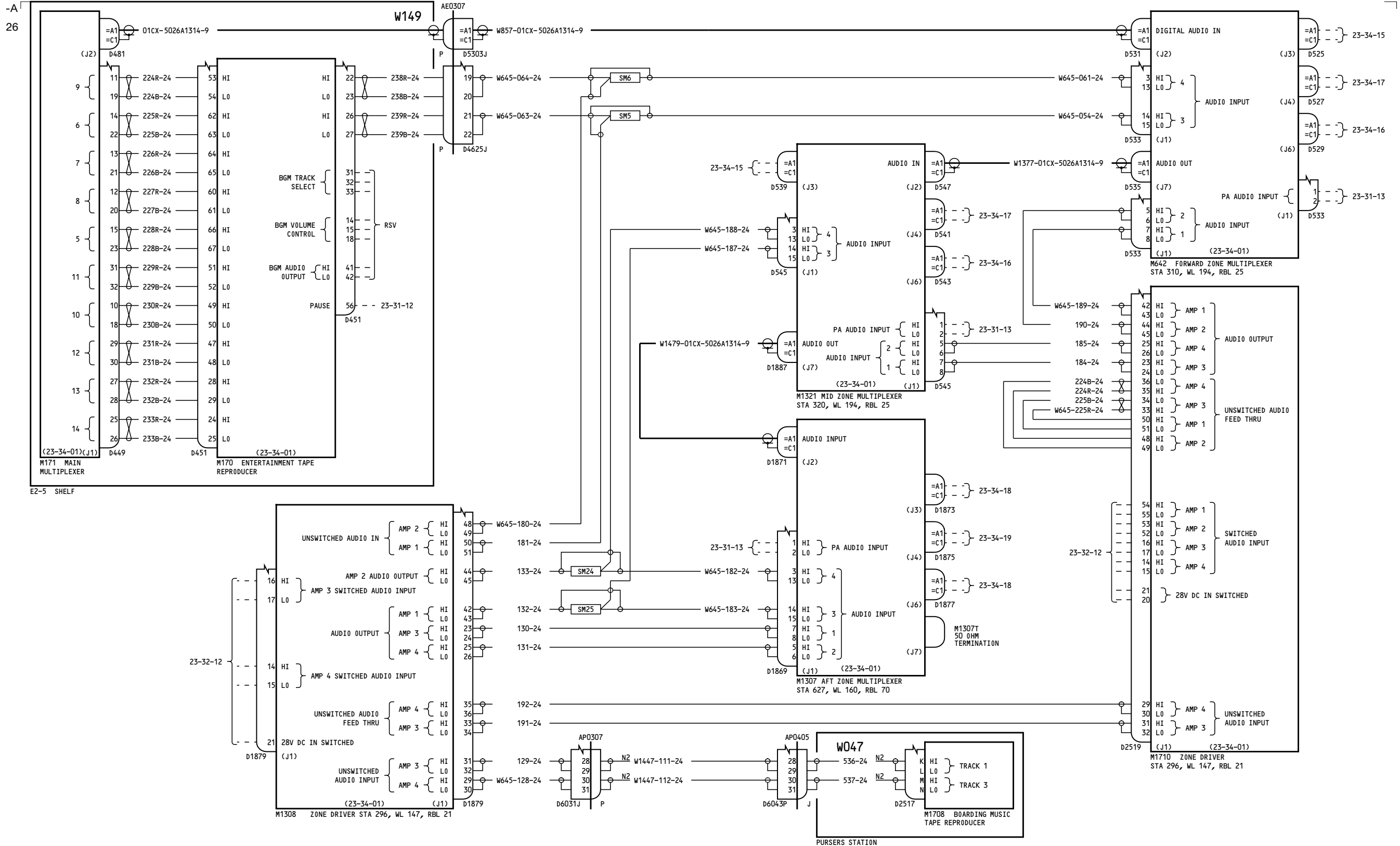

21

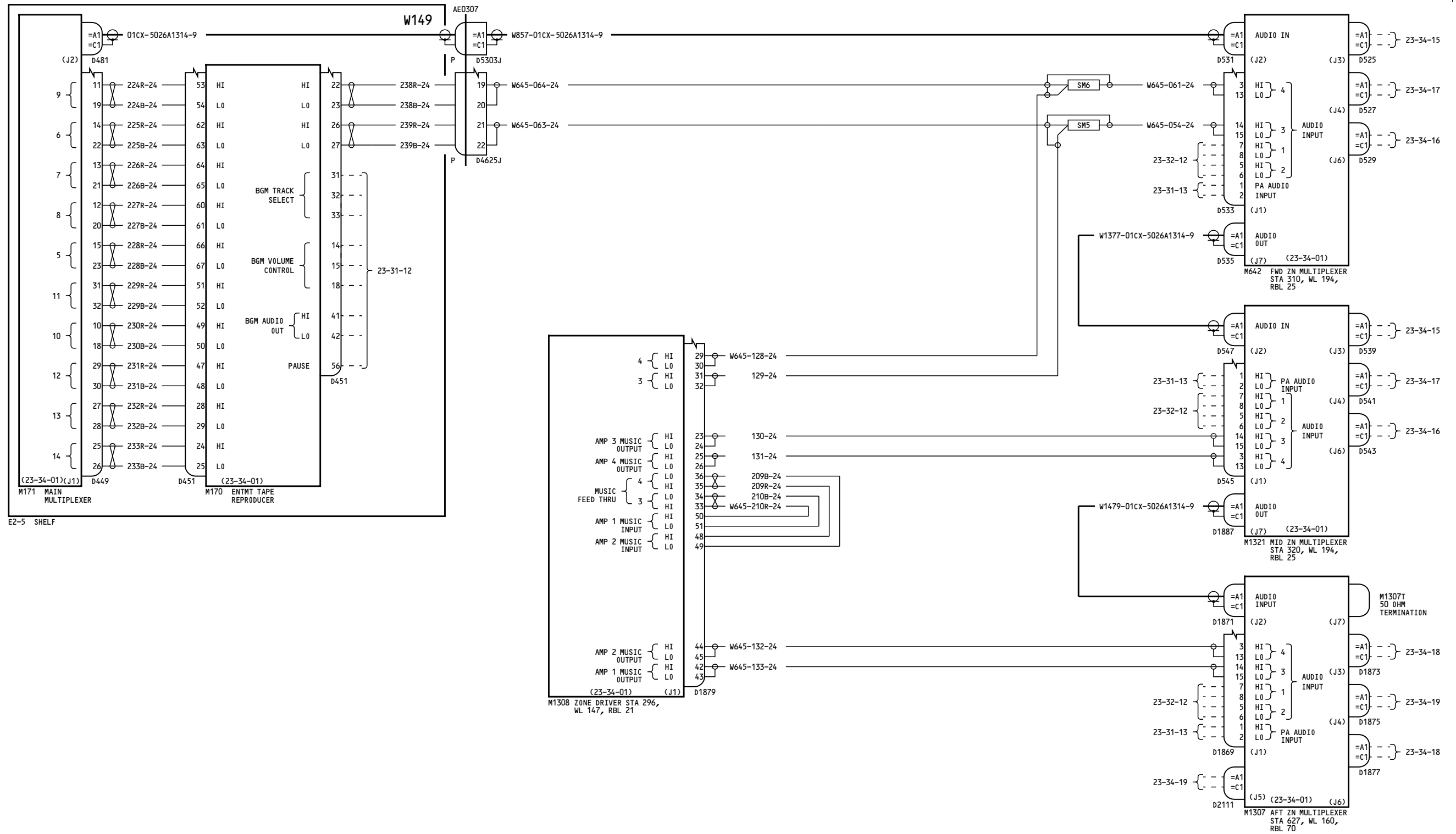

275-278

PASSENGER ENTERTAINMENT PASSENGER SERVICE

23-34-14

Page 4

D280T132

Jan 21/2005

23-34-14

Page 4

Jan 21/2005

35

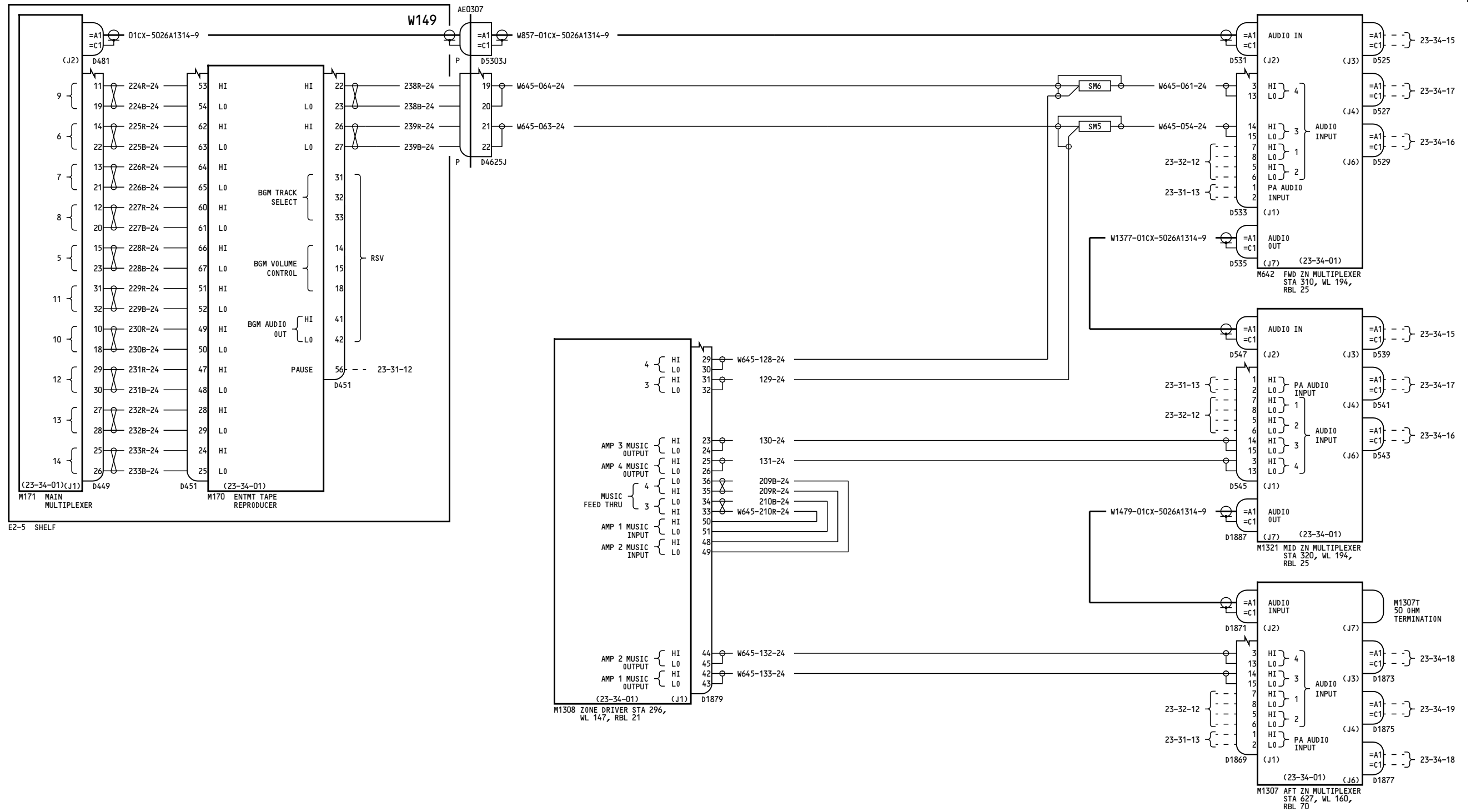

280-299

PASSENGER ENTERTAINMENT PASSENGER SERVICE

23-34-14

Page 5

D280T132

Jan 21/2005

23-34-14

Page 5

Jan 21/2005

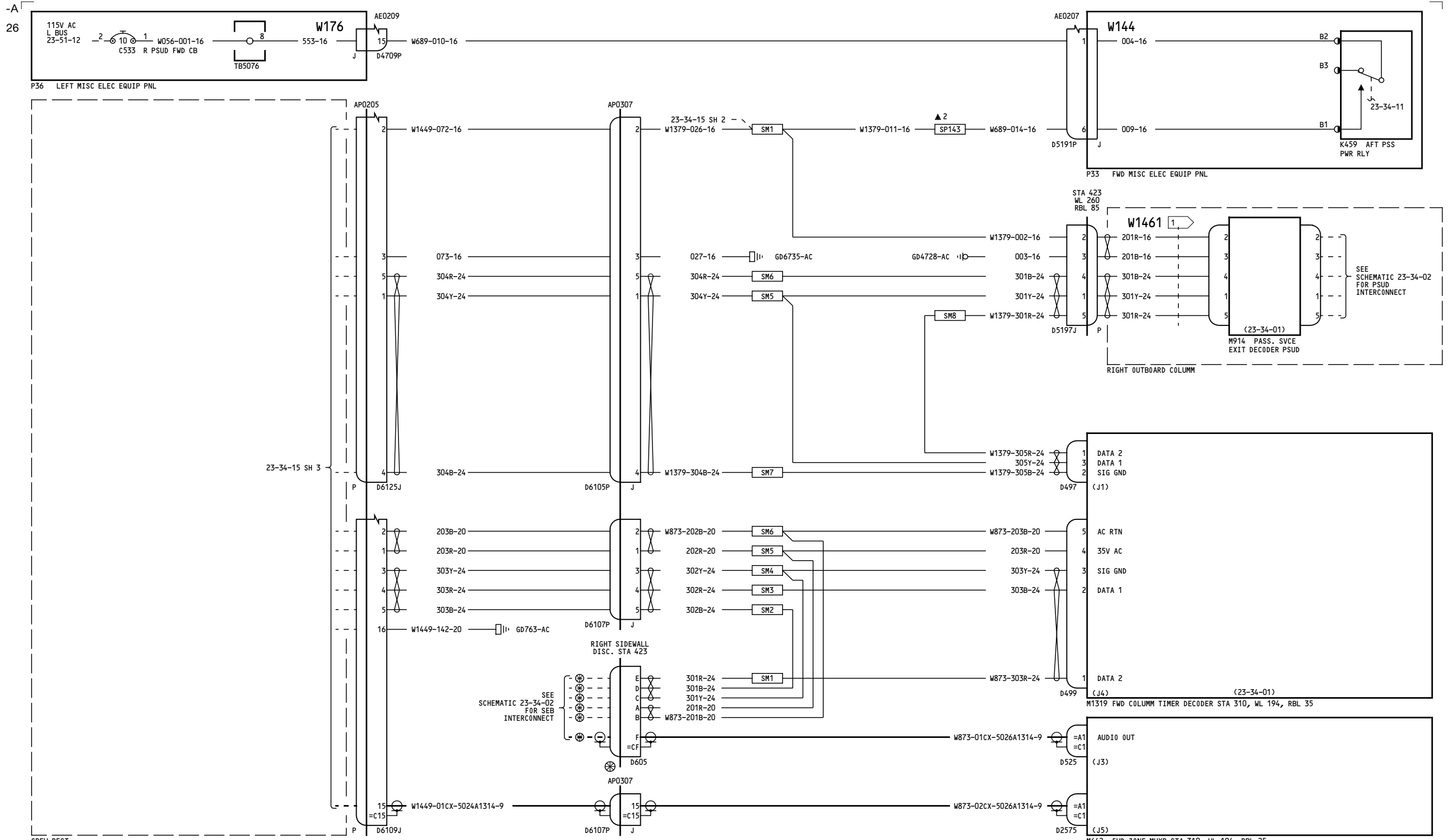

CREW REST
 NOTES:
 1 USE WIRE BUNDLE W1461, W1463, W1465, W1467, W1469, W1471, W1473, W1475, W1477, W1479,
 AS REQUIRED OR WHEN VIDEO PROJECTOR IS INSTALLED USE W037 OR W039 AS SHOWN ON 23-34-19

26

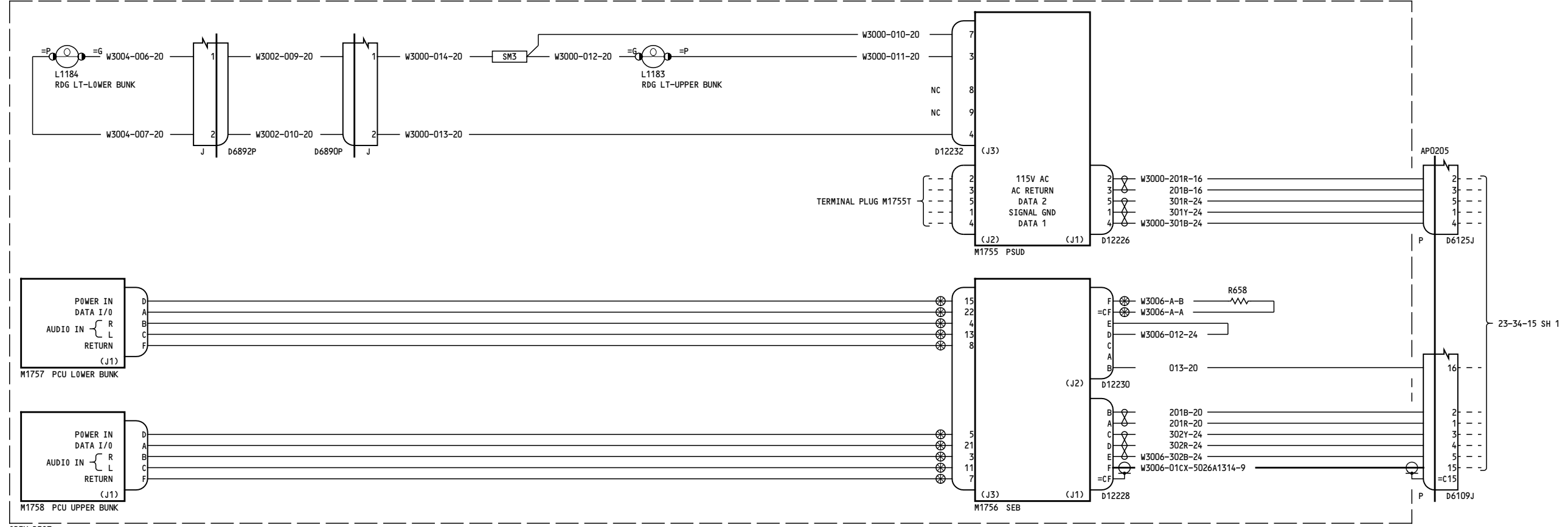
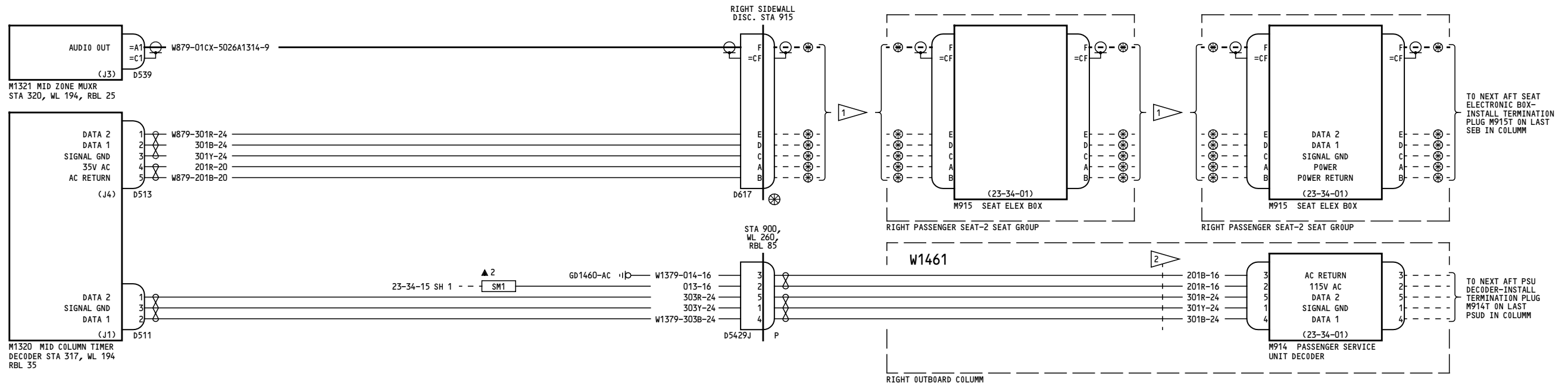

NOTES:

1 INSTALL CABLE ASSY PER S280T000-1

2 USE WIRE BUNDLE W1461, W1463, W1465, W1467, W1469, W1471, W1473, W1475, W1477, W1479, AS REQUIRED OR WHEN VIDEO PROJECTOR IS INSTALLED USE W037 OR W039 AS SHOWN ON 23-34-19

050-099

PASSENGER ENTERTAINMENT PASSENGER SERVICE

D280T132

23-34-15

Page 1
Sheet 2
Jan 21/2005

23-34-15

Page 1
Sheet 2
Jan 21/2005

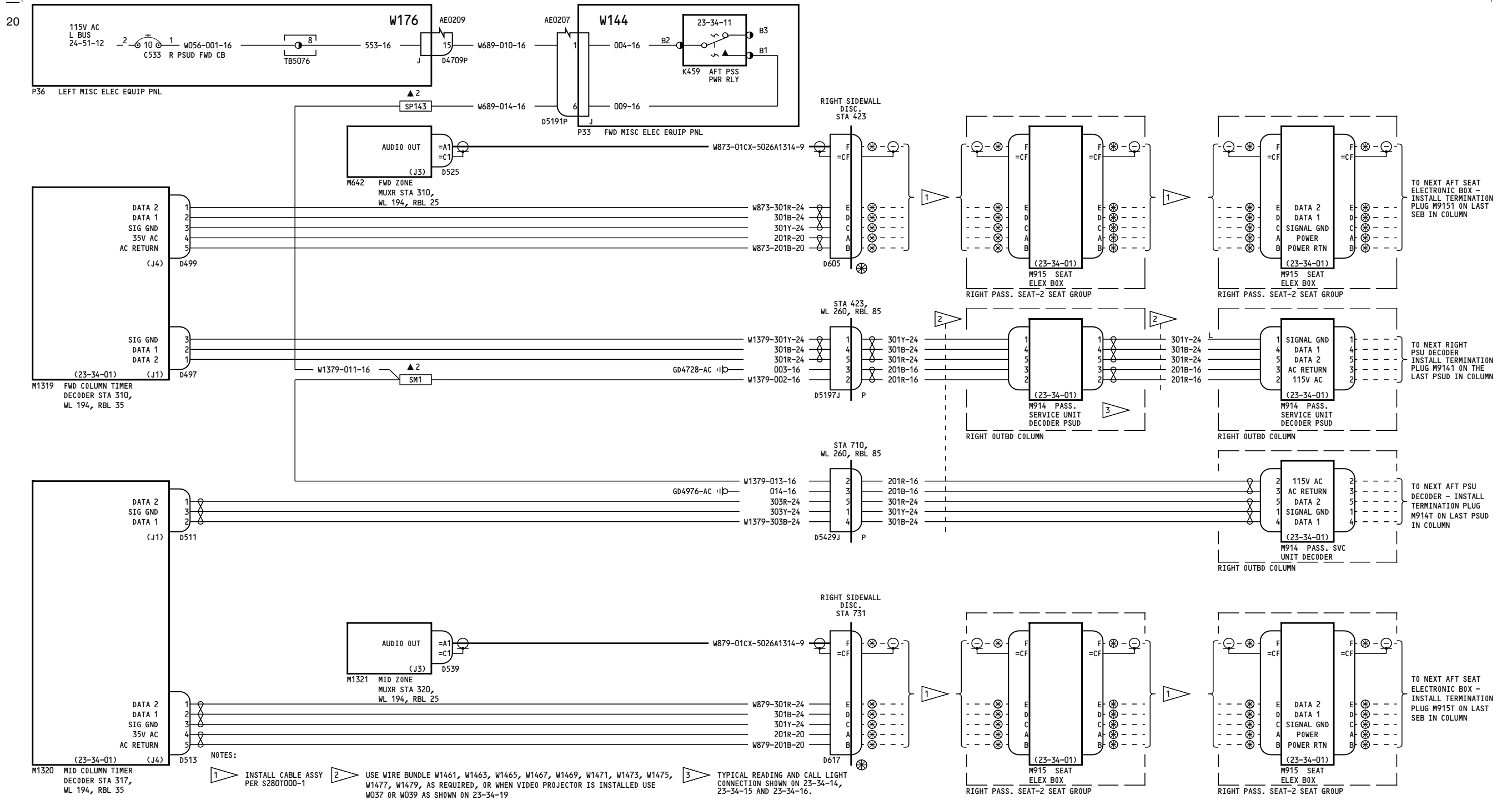

NOTES:

1 INSTALL CABLE ASSY PER S280T000-1

2 USE WIRE BUNDLE W1461, W1463, W1465, W1467, W1469, W1471, W1473, W1475, W1477, W1479, AS REQUIRED, OR WHEN VIDEO PROJECTOR IS INSTALLED USE W037 OR W039 AS SHOWN ON 23-34-19

3 TYPICAL READING AND CALL LIGHT CONNECTION SHOWN ON 23-34-14, 23-34-15 AND 23-34-16.

-A
28

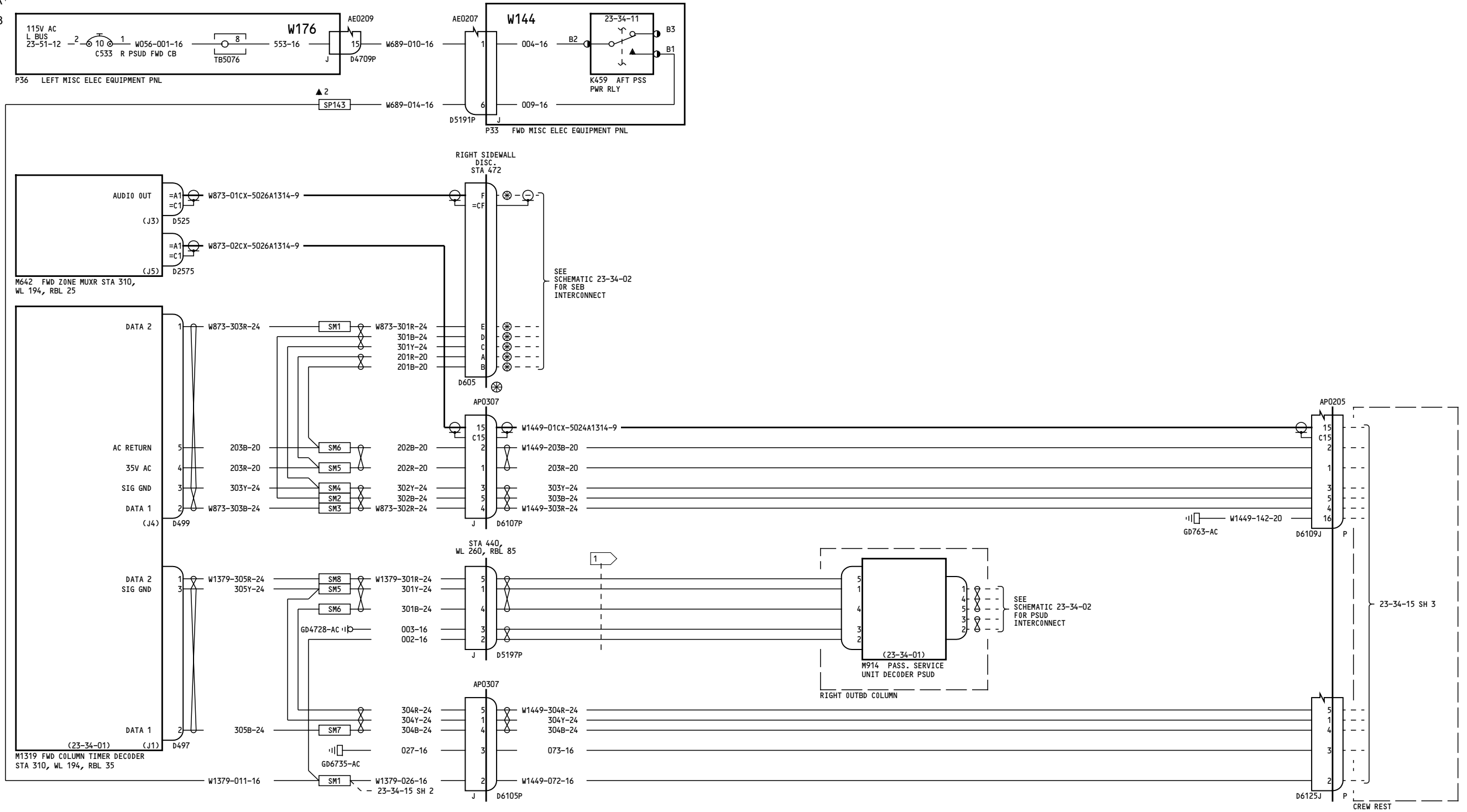

NOTES:
 1 USE WIRE BUNDLE W1463, W1465, W1467, W1469, W1471, W1473, W1475, W1477, W1479, AS REQUIRED, OR WHEN VIDEO PROJECTOR IS INSTALLED USE W037 OR W039 AS SHOWN ON 23-34-19

162-199

**PASSENGER ENTERTAINMENT
PASSENGER SERVICE**

23-34-15

Page 3
Sheet 1
Aug 05/2009

D280T132

23-34-15

Page 3
Sheet 1
Aug 05/2009

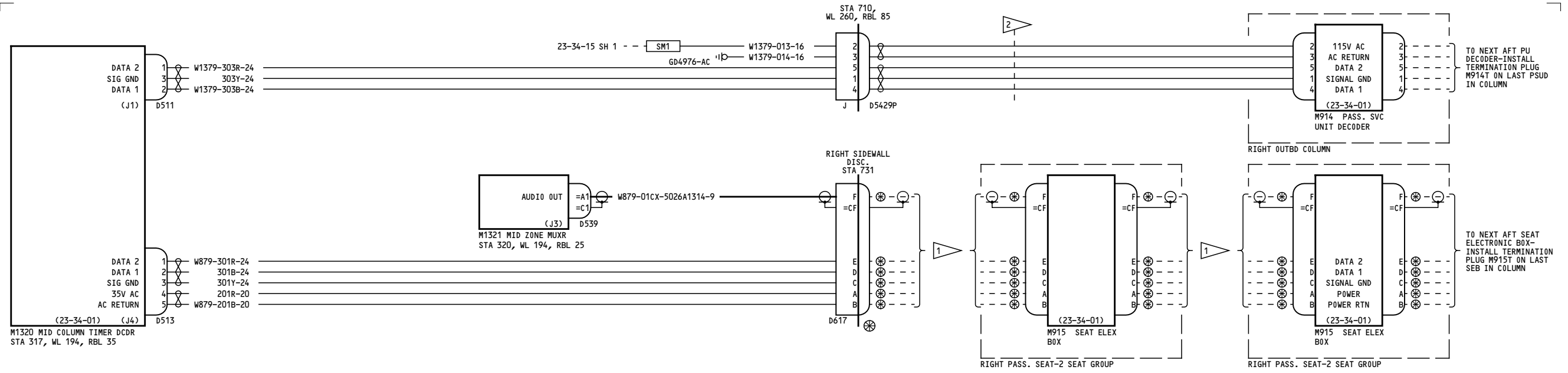

- NOTES:
- 1 INSTALL CABLE ASSY PER S280T000-1
 - 2 USE WIRE BUNDLE W1463, W1465, W1467, W1469, W1471, W1473, W1475, W1477, W1479, AS REQUIRED, OR WHEN VIDEO PROJECTOR IS INSTALLED USE W037 OR W039 AS SHOWN ON 23-34-19

162-199

PASSENGER ENTERTAINMENT
PASSENGER SERVICE

D280T132

23-34-15

Page 3
Sheet 2
Jan 21/2005

23-34-15

Page 3
Sheet 2
Jan 21/2005

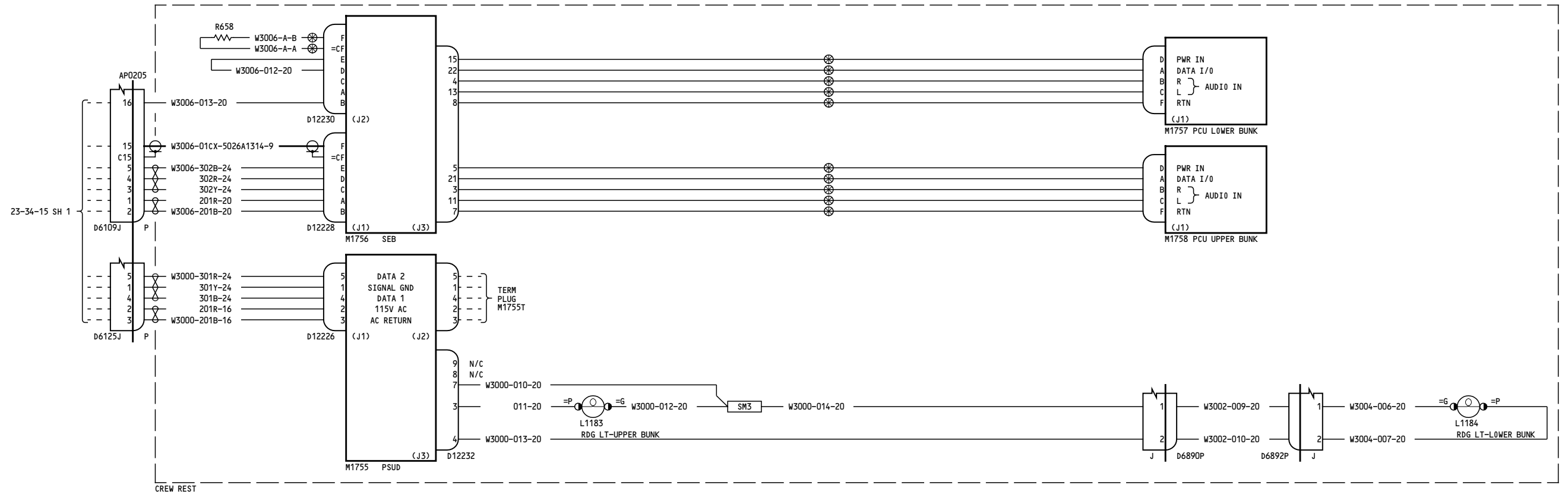

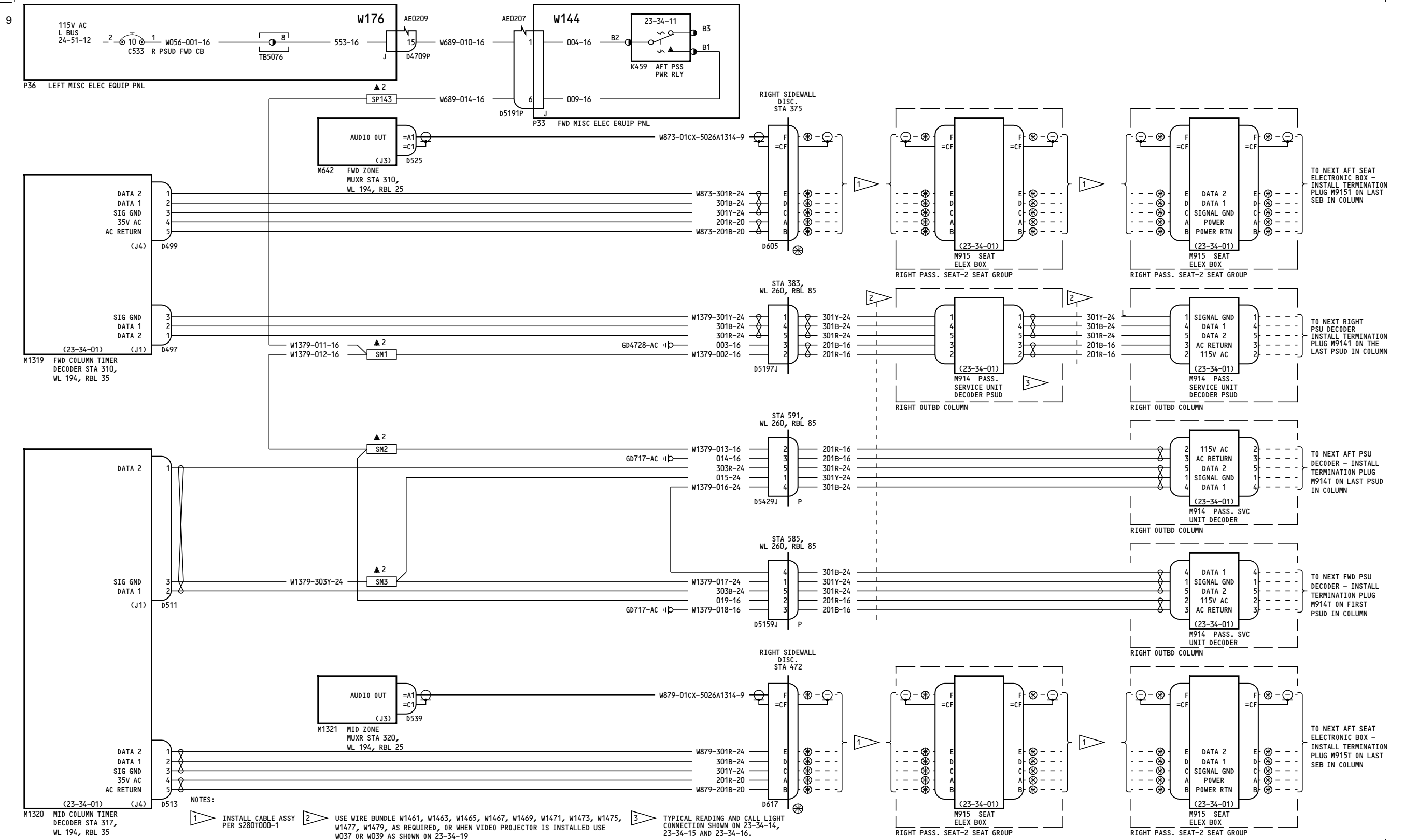

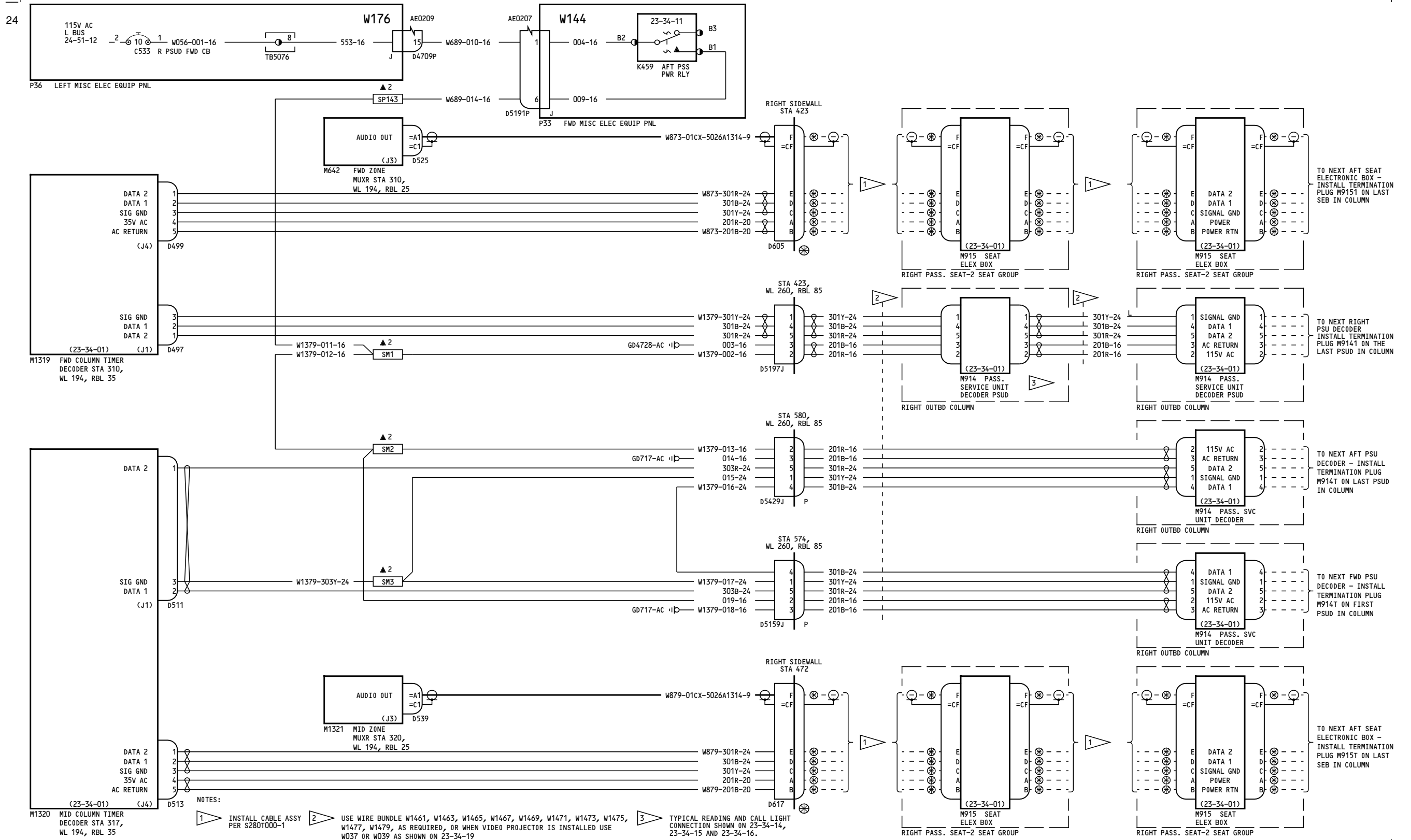

NOTES:
 1 INSTALL CABLE ASSY PER S280T000-1
 2 USE WIRE BUNDLE W1461, W1463, W1465, W1467, W1469, W1471, W1473, W1475, W1477, W1479, AS REQUIRED, OR WHEN VIDEO PROJECTOR IS INSTALLED USE W037 OR W039 AS SHOWN ON 23-34-19
 3 TYPICAL READING AND CALL LIGHT CONNECTION SHOWN ON 23-34-14, 23-34-15 AND 23-34-16.

276-278

PASSENGER ENTERTAINMENT PASSENGER SERVICE

23-34-15

Page 5

Jan 21/2005

D280T132

23-34-15

Page 5

Jan 21/2005

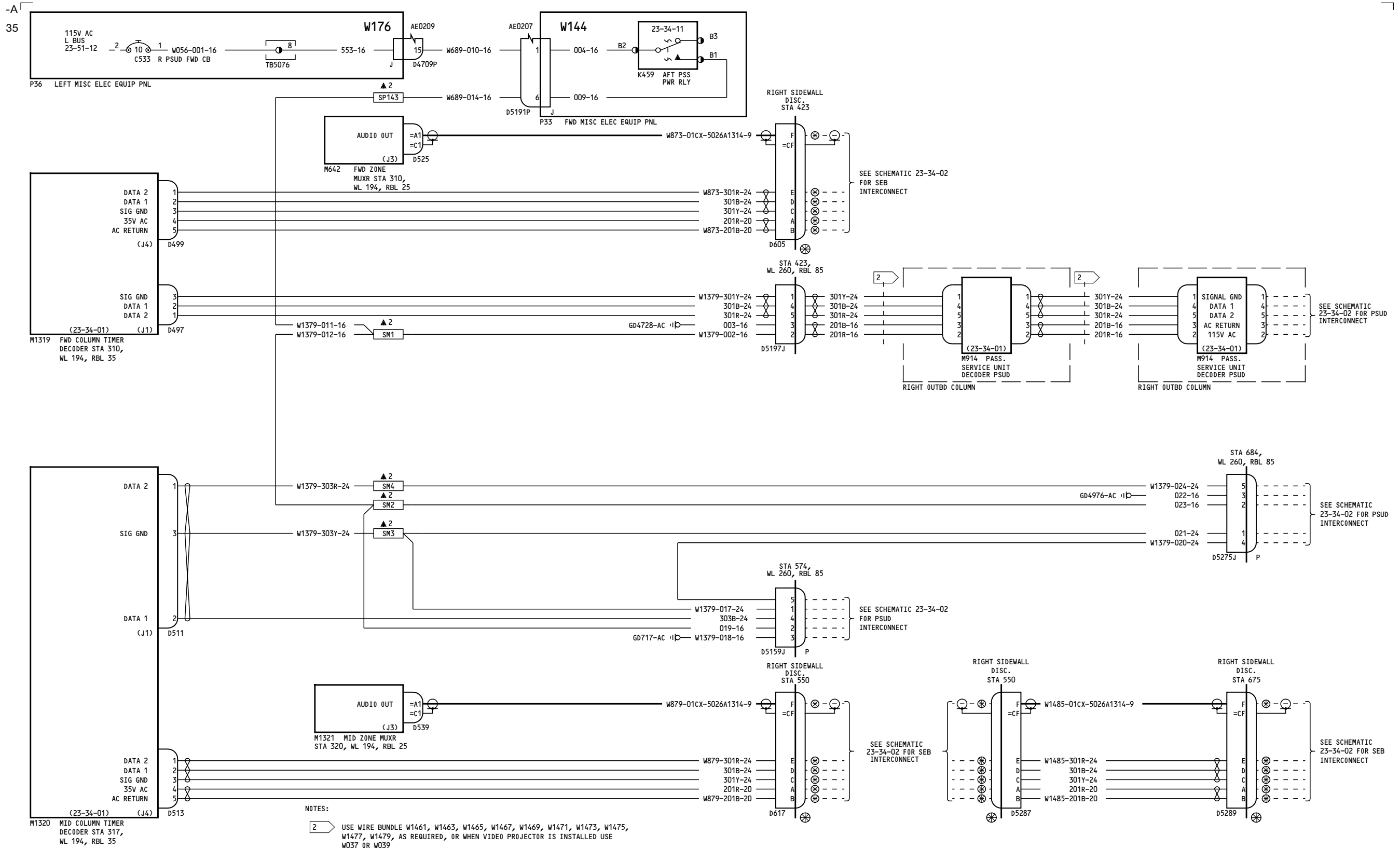

280-299

PASSENGER ENTERTAINMENT PASSENGER SERVICE

23-34-15

Page 6

D280T132

Aug 05/2009

23-34-15

Page 6

Aug 05/2009

24

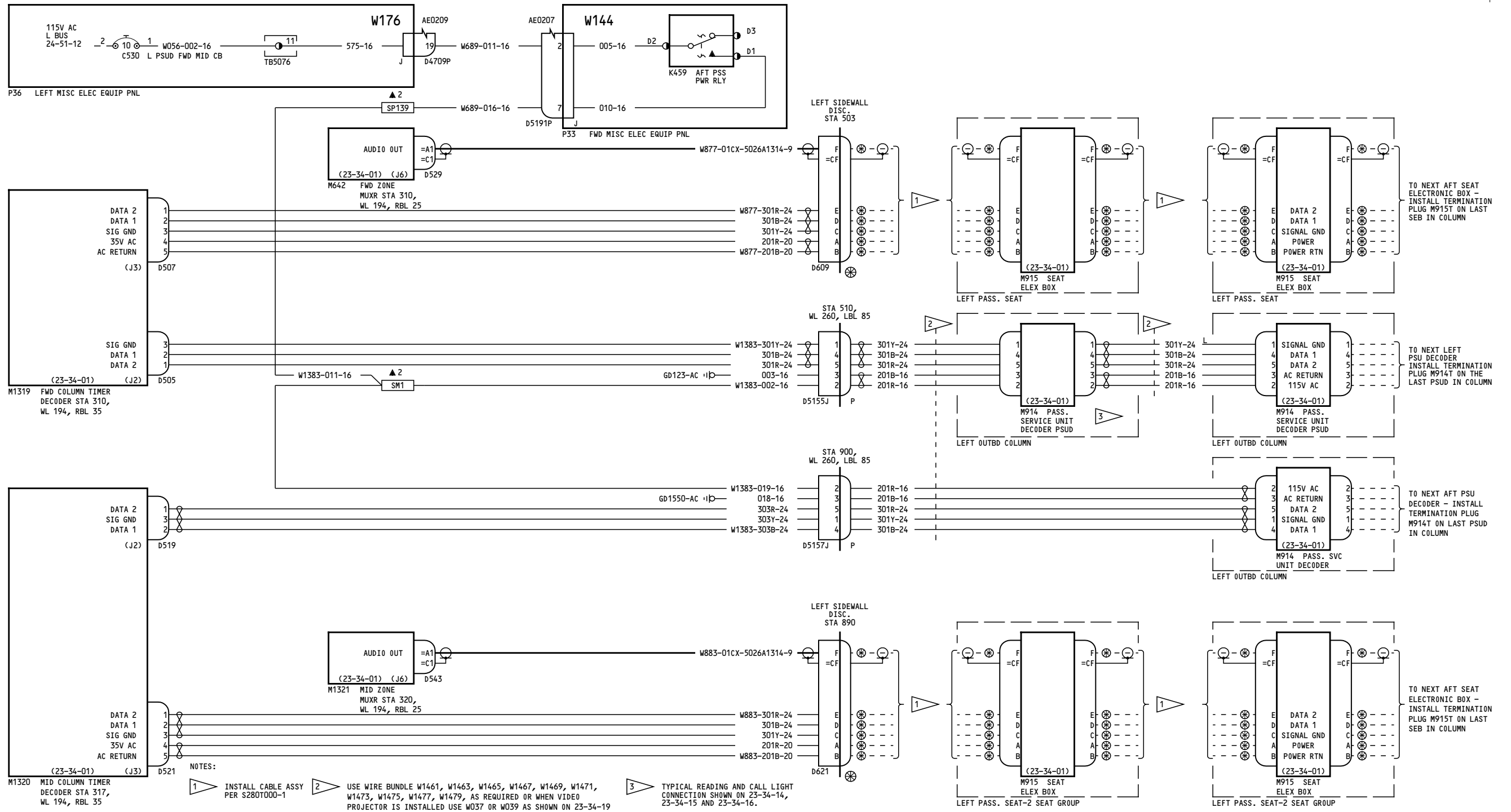

050-099

PASSENGER ENTERTAINMENT PASSENGER SERVICE

23-34-16

Page 1

D280T132

Jan 21/2005

23-34-16

Page 1

Jan 21/2005

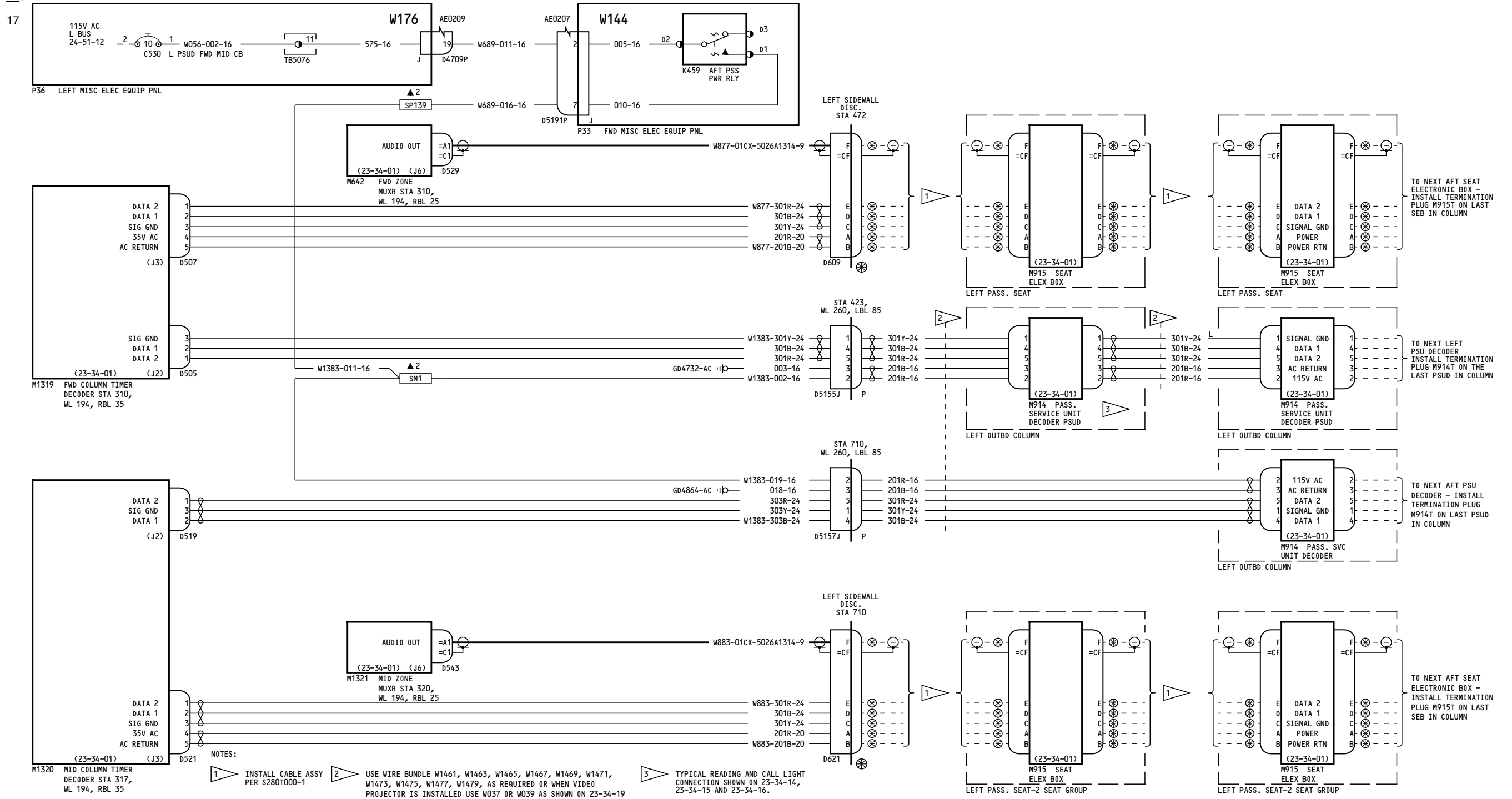

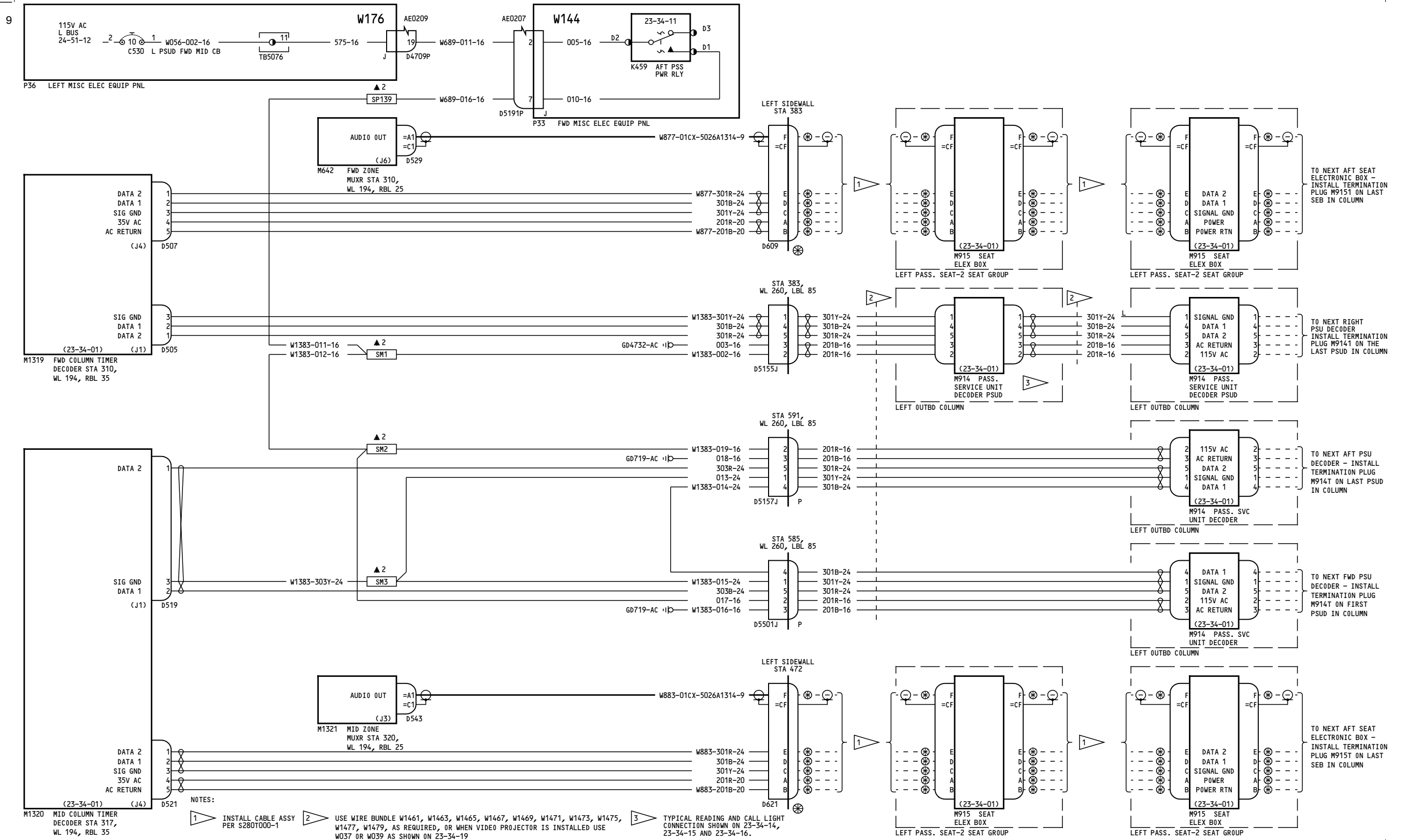

NOTES:
 1 INSTALL CABLE ASSY PER S280T000-1
 2 USE WIRE BUNDLE W1461, W1463, W1465, W1467, W1469, W1471, W1473, W1475, W1477, W1479, AS REQUIRED, OR WHEN VIDEO PROJECTOR IS INSTALLED USE W037 OR W039 AS SHOWN ON 23-34-19
 3 TYPICAL READING AND CALL LIGHT CONNECTION SHOWN ON 23-34-14, 23-34-15 AND 23-34-16.

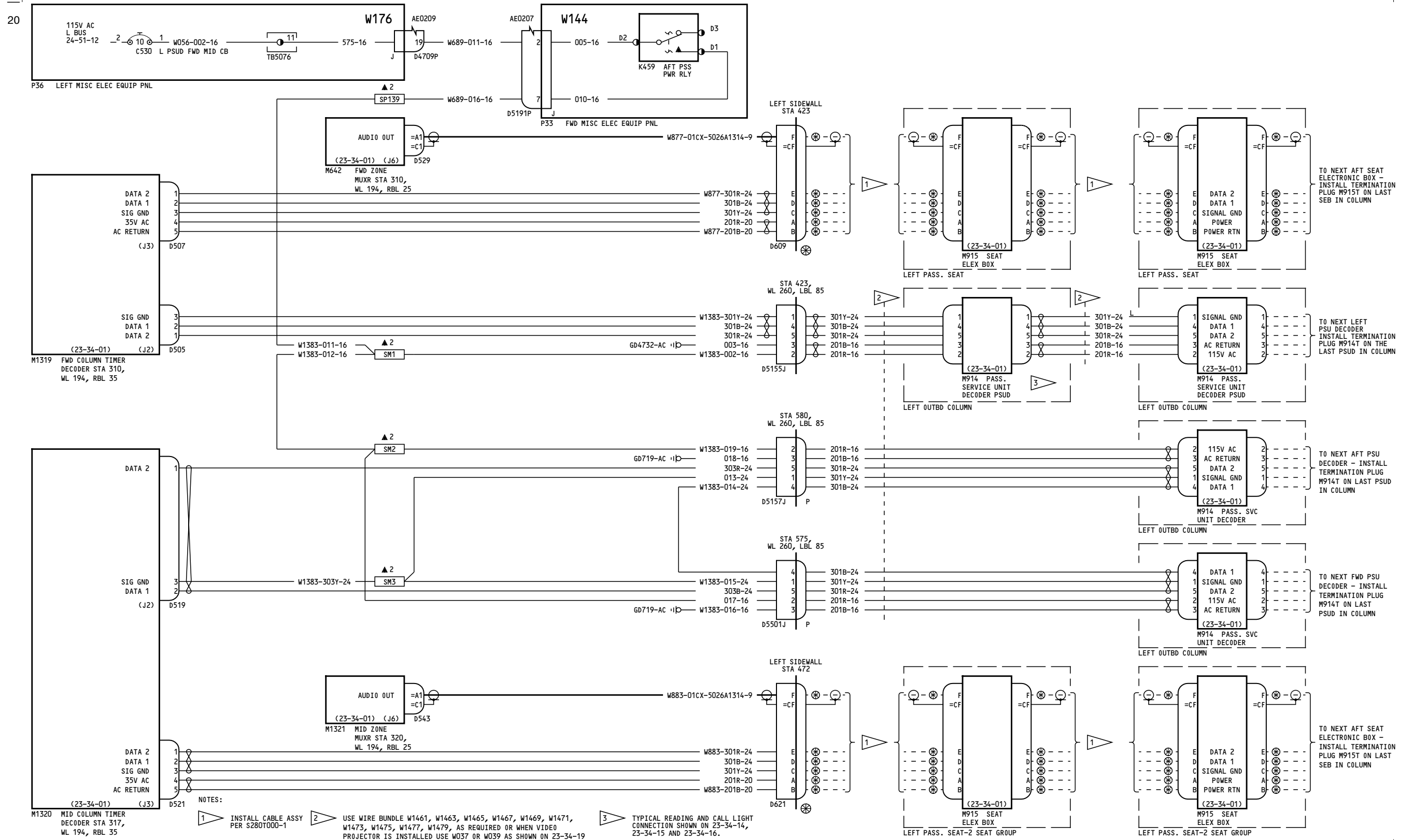

276-278

PASSENGER ENTERTAINMENT PASSENGER SERVICE

23-34-16

Page 4

D280T132

Jan 21/2005

23-34-16

Page 4

Jan 21/2005

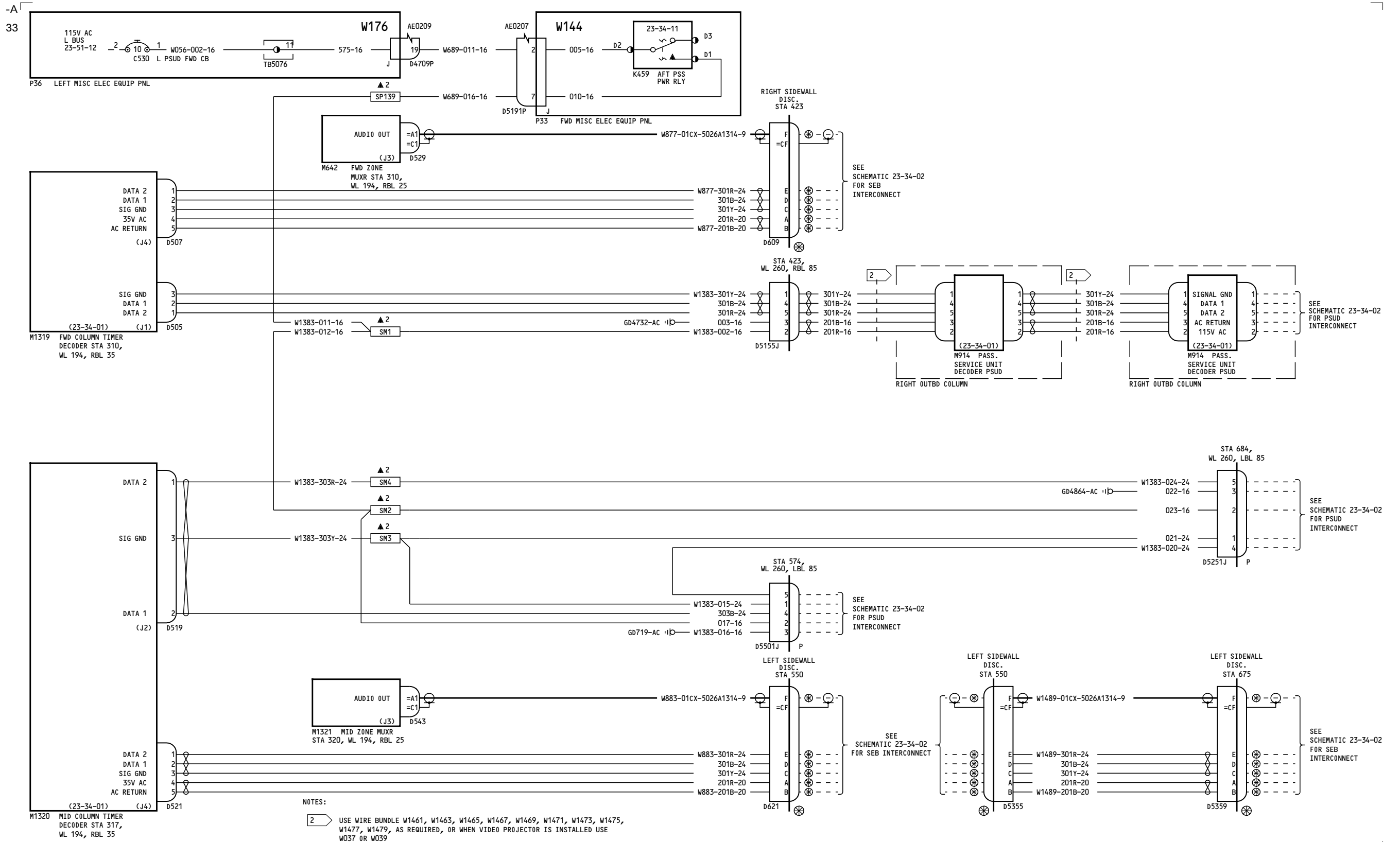

280-299

**PASSENGER ENTERTAINMENT
PASSENGER SERVICE**

23-34-16

Page 5

D280T132

Aug 05/2009

23-34-16

Page 5

Aug 05/2009

29

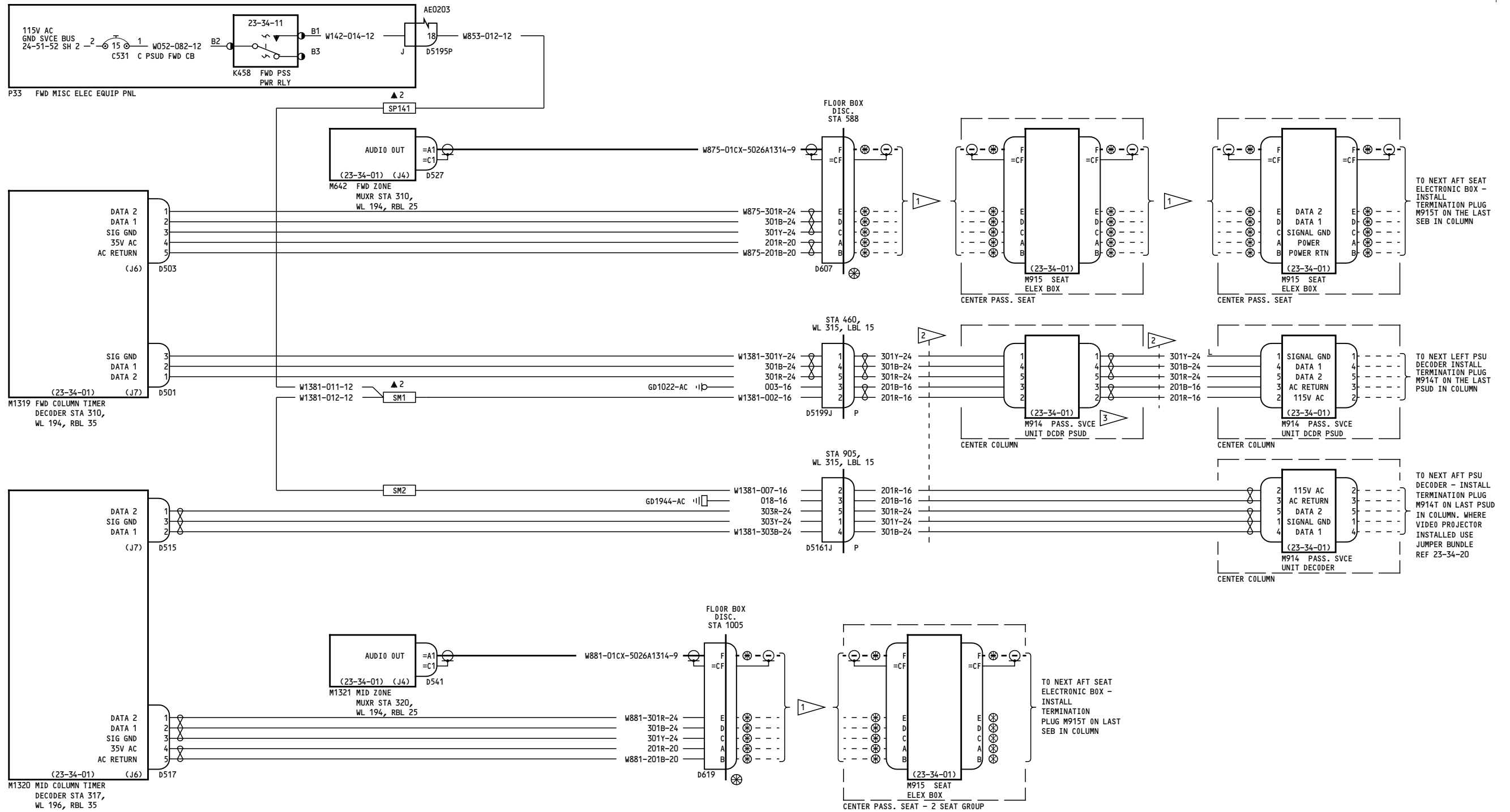

- NOTES:
- 1 INSTALL CABLE ASSY PER S280T000
 - 2 USE WIRE BUNDLE W1461, W1463, W1465, W1467, W1469, W1471, W1473, W1475, W1477, W1479, AS REQUIRED OR WHEN VIDEO PROJECTOR IS INSTALLED USE W037 OR W039 AS SHOWN ON 23-34-19.
 - 3 TYPICAL READING AND CALL LIGHT CONNECTION SHOWN ON 23-34-14, 23-34-15 AND 23-34-16.

050-099

PASSENGER ENTERTAINMENT PASSENGER SERVICE

D280T132

23-34-17

Page 1

Jan 21/2005

23-34-17

Page 1

Jan 21/2005

22

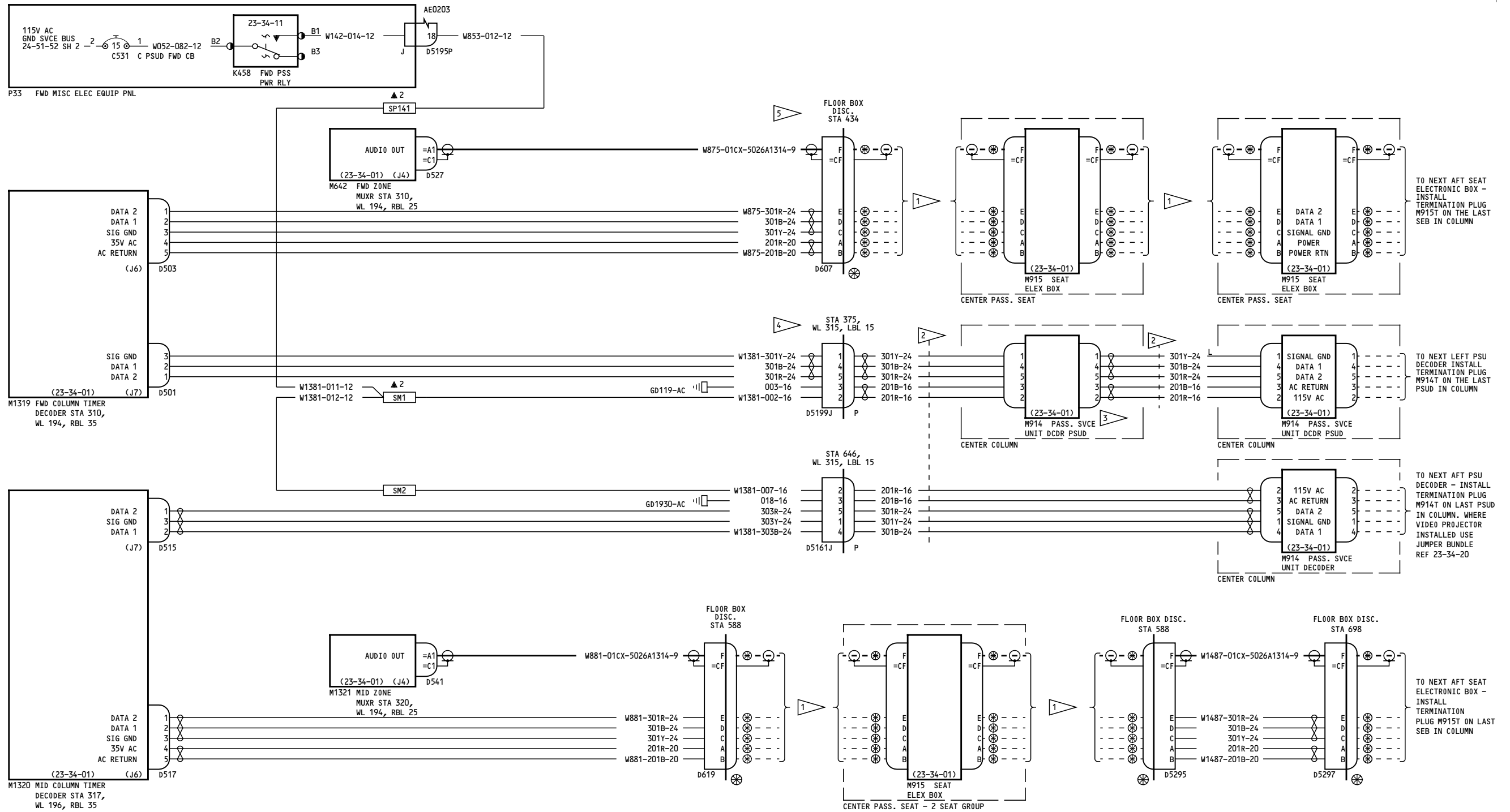

- NOTES:
- 1 INSTALL CABLE ASSY PER S280T000
 - 2 USE WIRE BUNDLE W1461, W1463, W1465, W1467, W1469, W1471, W1473, W1475, W1477, W1479, AS REQUIRED OR WHEN VIDEO PROJECTOR IS INSTALLED USE W037 OR W039 AS SHOWN ON 23-34-19.
 - 3 TYPICAL READING AND CALL LIGHT CONNECTION SHOWN ON 23-34-14, 23-34-15 AND 23-34-16.
 - 4 STA 385 FOR VN154-VN162 STA 460 FOR VN163-VN170
 - 5 STA 588 FOR VN163-VN170

150-199

**PASSENGER ENTERTAINMENT
PASSENGER SERVICE**

D280T132

23-34-17

Page 2

Jan 21/2005

23-34-17

Page 2

Jan 21/2005

24

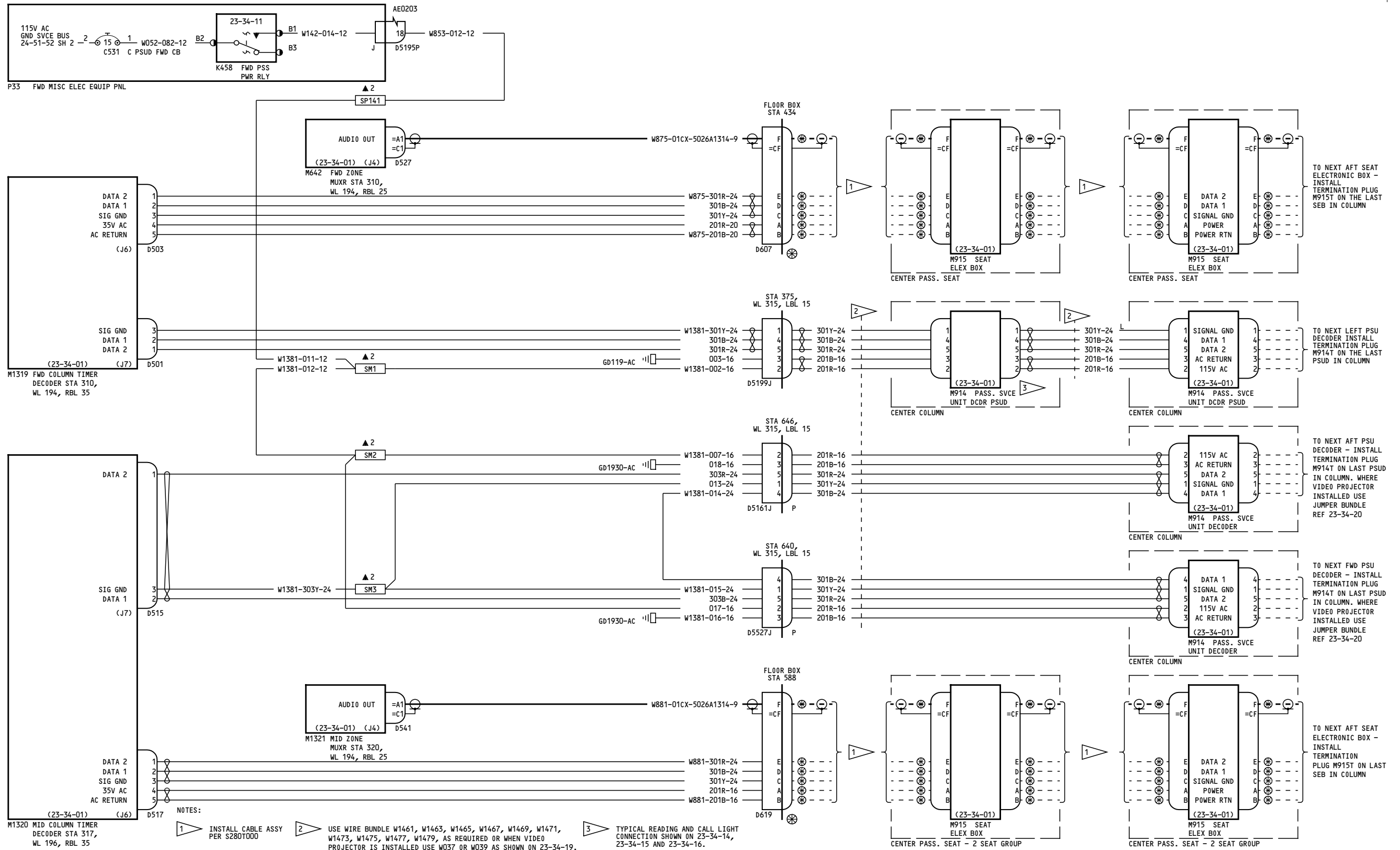

275-278

PASSENGER ENTERTAINMENT PASSENGER SERVICE

23-34-17

Page 3

D280T132

Jan 21/2005

23-34-17

Page 3

Jan 21/2005

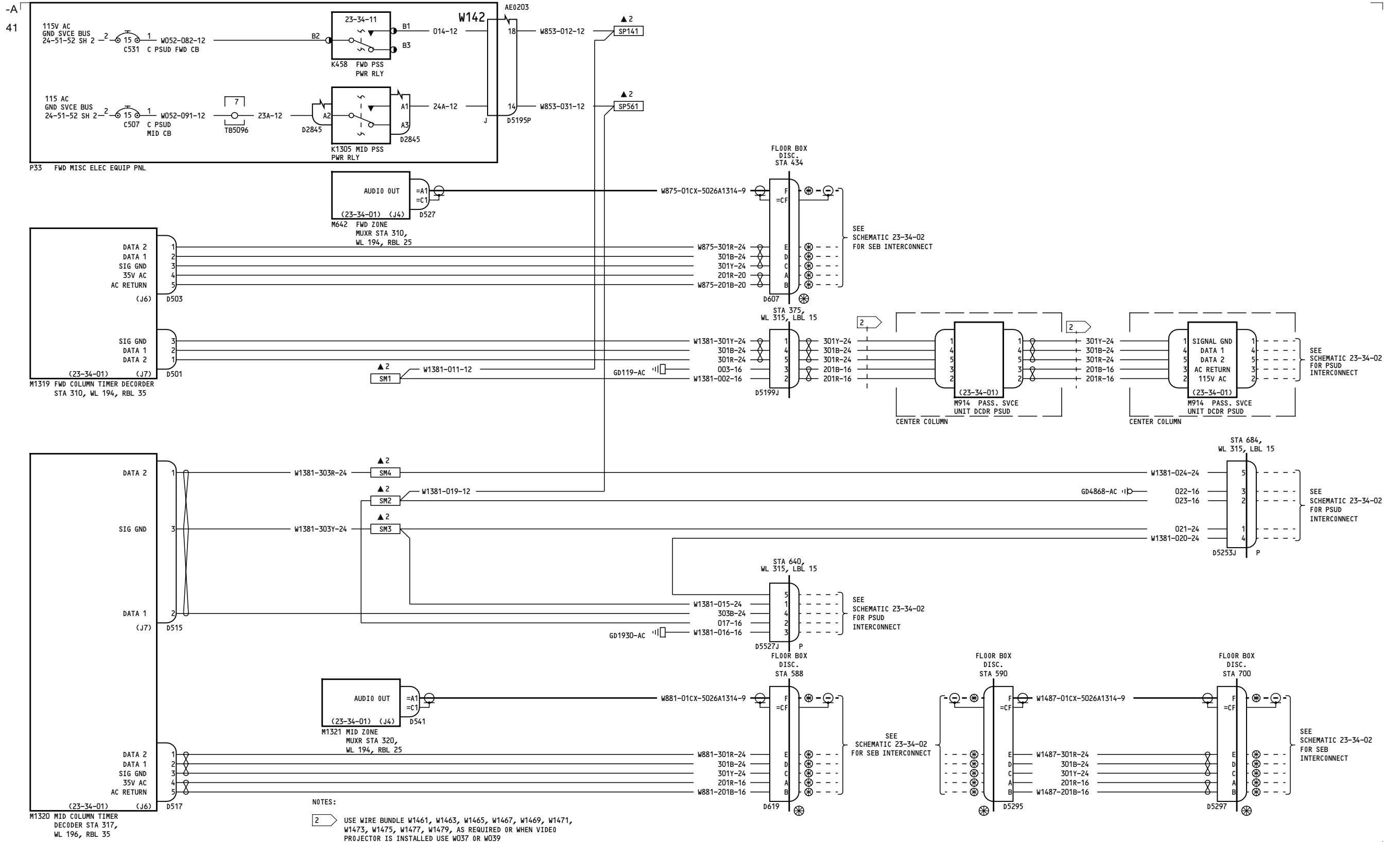

280-299

**PASSENGER ENTERTAINMENT
PASSENGER SERVICE**

23-34-17

Page 4

D280T132

Aug 05/2009

23-34-17

Page 4

Aug 05/2009

-A
21

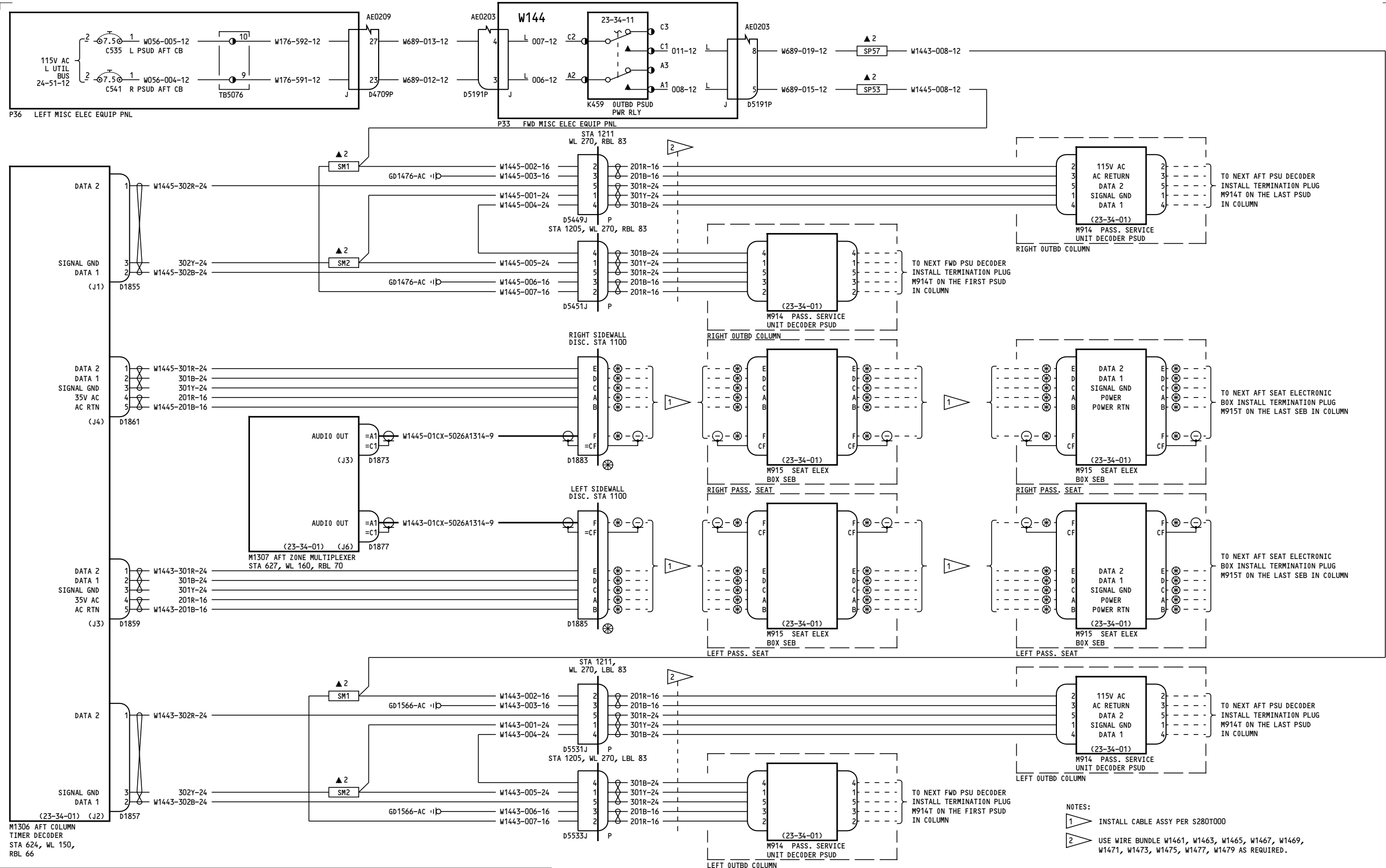

050-099

**PASSENGER ENTERTAINMENT
PASSENGER SERVICE**

23-34-18

Page 1

D280T132

Jan 21/2005

23-34-18

Page 1

Jan 21/2005

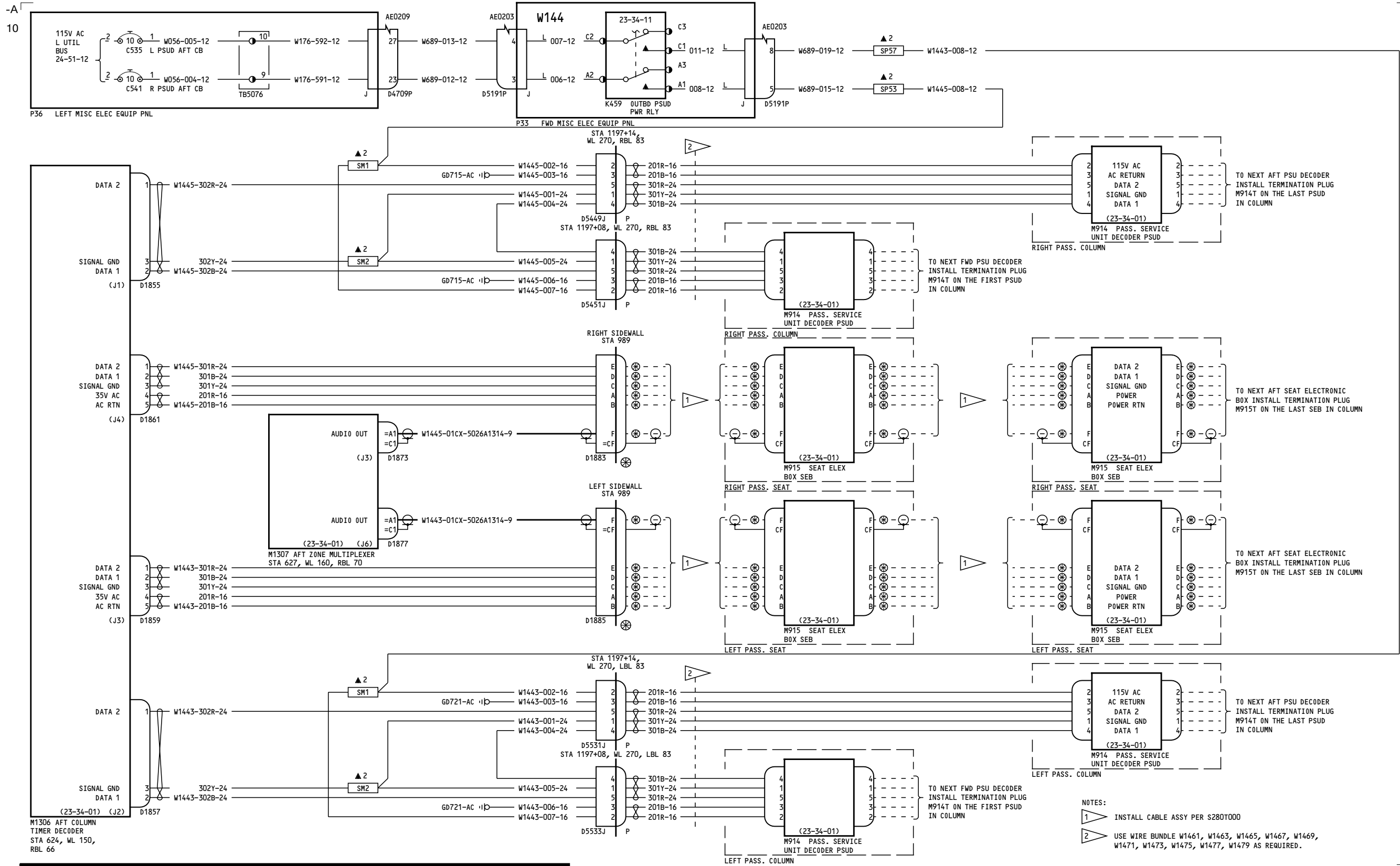

- NOTES:
- 1 INSTALL CABLE ASSY PER S280T000
 - 2 USE WIRE BUNDLE W1461, W1463, W1465, W1467, W1469, W1471, W1473, W1475, W1477, W1479 AS REQUIRED.

150-199, 275-299

**PASSENGER ENTERTAINMENT
PASSENGER SERVICE**

D280T132

23-34-18

23-34-18

12

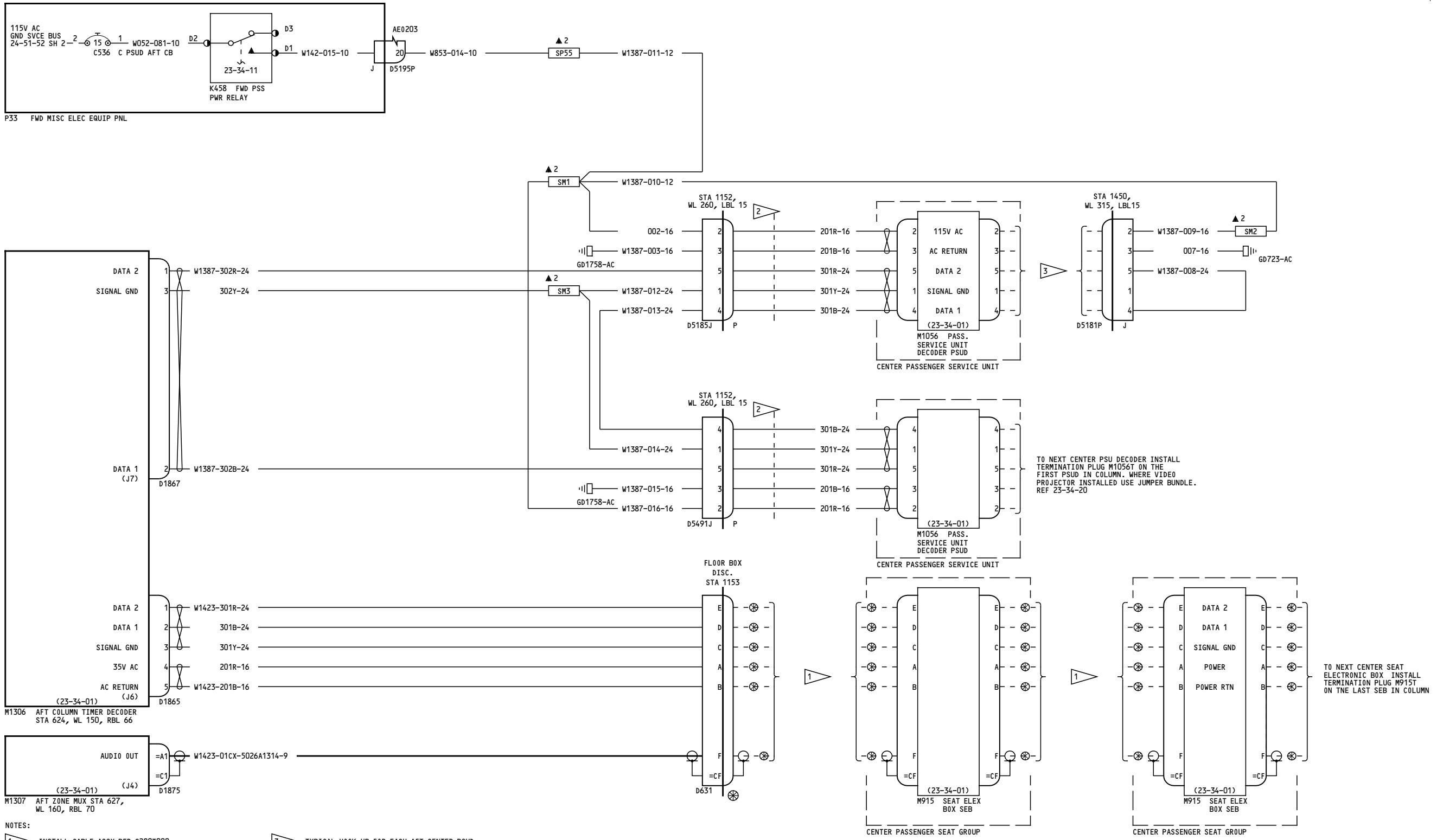

- NOTES:
- 1 INSTALL CABLE ASSY PER S280T000
 - 2 USE WIRE BUNDLE W1461, W1463, W1465, W1467, W1469, W1471, W1473, W1475, W1477, W1479 AS REQUIRED.
 - 3 TYPICAL HOOK-UP FOR EACH AFT CENTER PSUD

050-099	PASSENGER ENTERTAINMENT PASSENGER SERVICE	23-34-19	23-34-19
		Page 1	Page 1
	D280T132	Jan 21/2005	Jan 21/2005

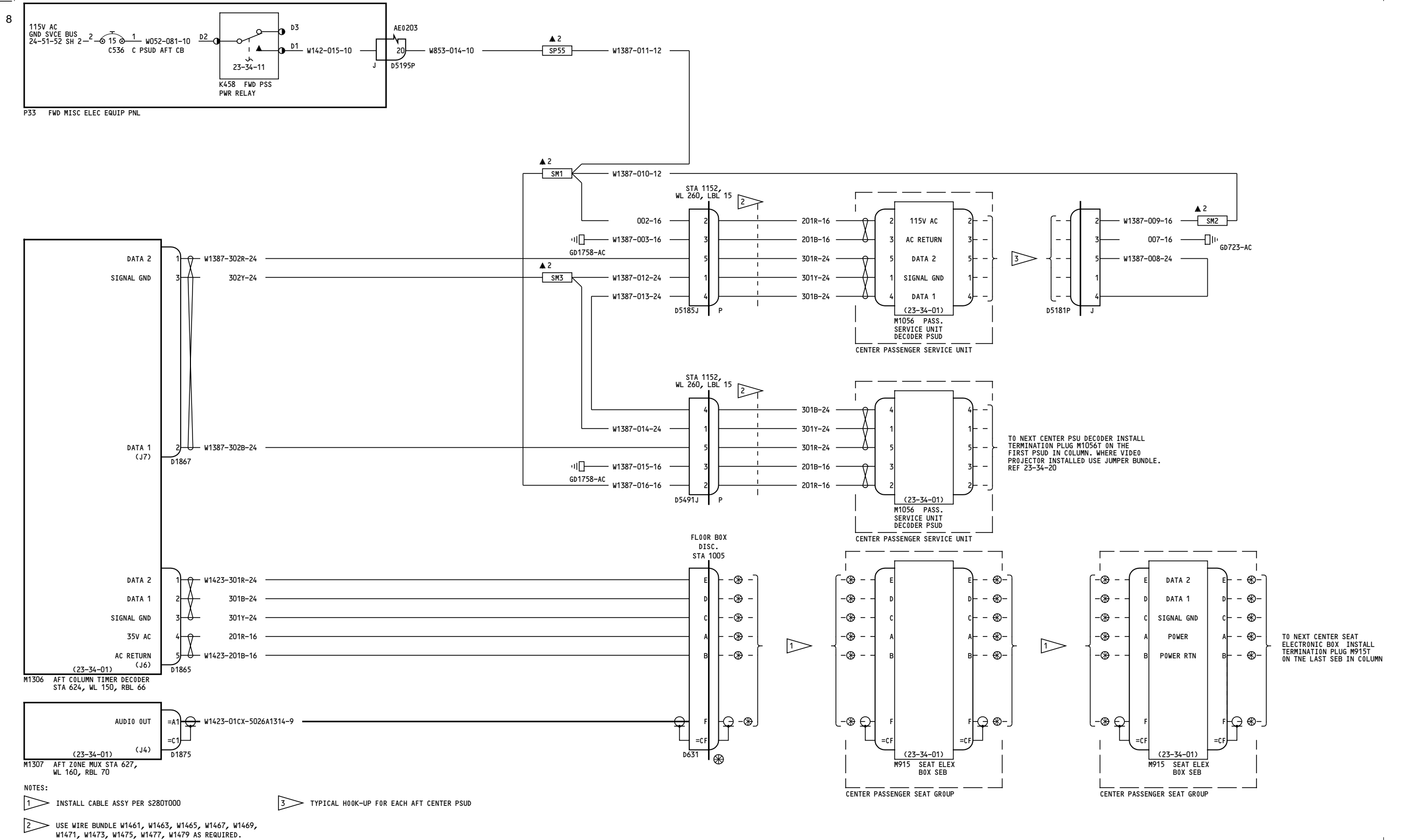

150-199

PASSENGER ENTERTAINMENT PASSENGER SERVICE

23-34-19

Page 2

D280T132

Jan 21/2005

23-34-19

Page 2

Jan 21/2005

26

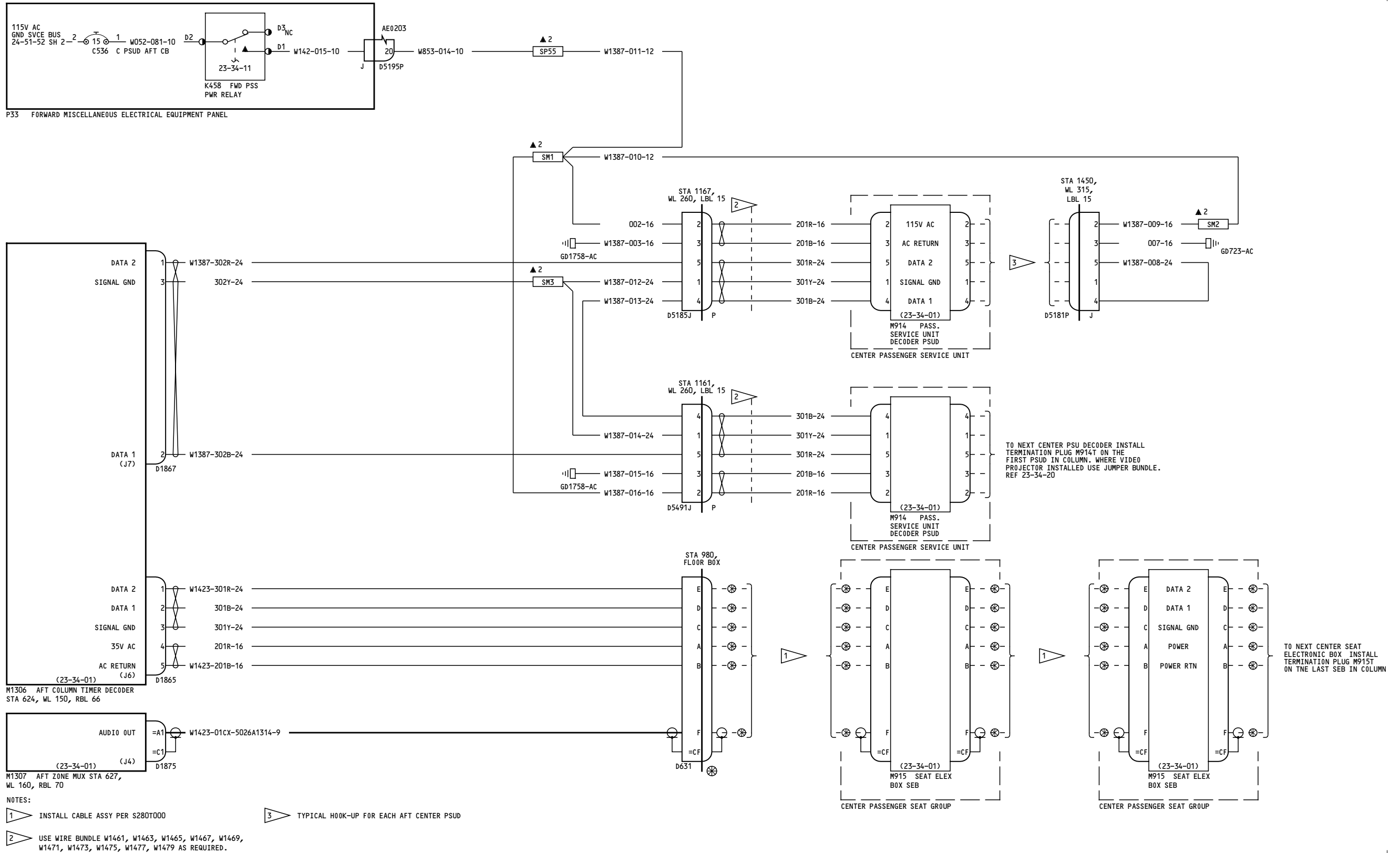

275-278

**PASSENGER ENTERTAINMENT
PASSENGER SERVICE**

23-34-19

Page 3

Jan 21/2005

D280T132

23-34-19

Page 3

Jan 21/2005

16

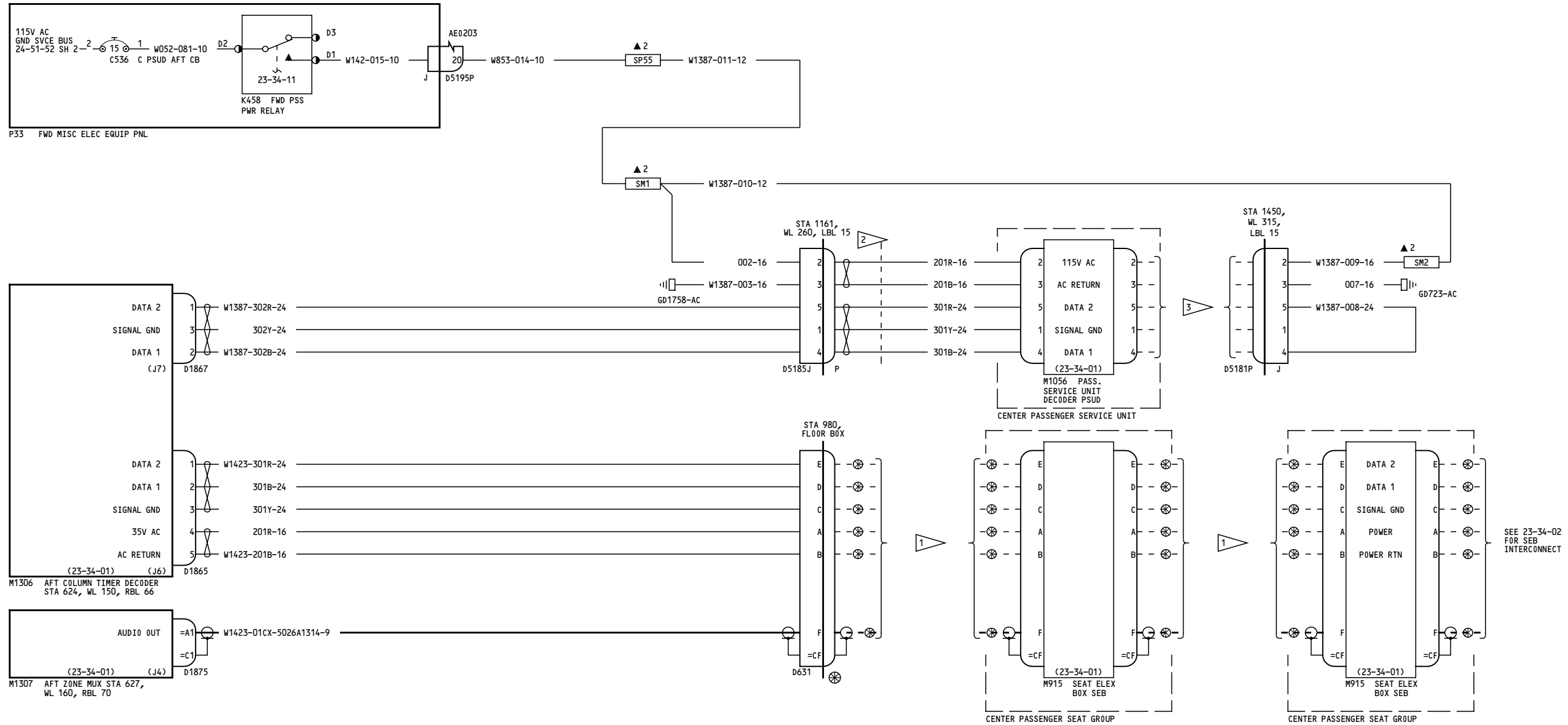

NOTES:

- 1 INSTALL CABLE ASSY PER S280T000
- 2 USE WIRE BUNDLE W1461, W1463, W1465, W1467, W1469, W1471, W1473, W1475, W1477, W1479 AS REQUIRED.
- 3 TYPICAL HOOK-UP FOR EACH AFT CENTER PSUD

280-299

PASSENGER ENTERTAINMENT
PASSENGER SERVICE

23-34-19

Page 4

D280T132

Jan 21/2005

23-34-19

Page 4

Jan 21/2005

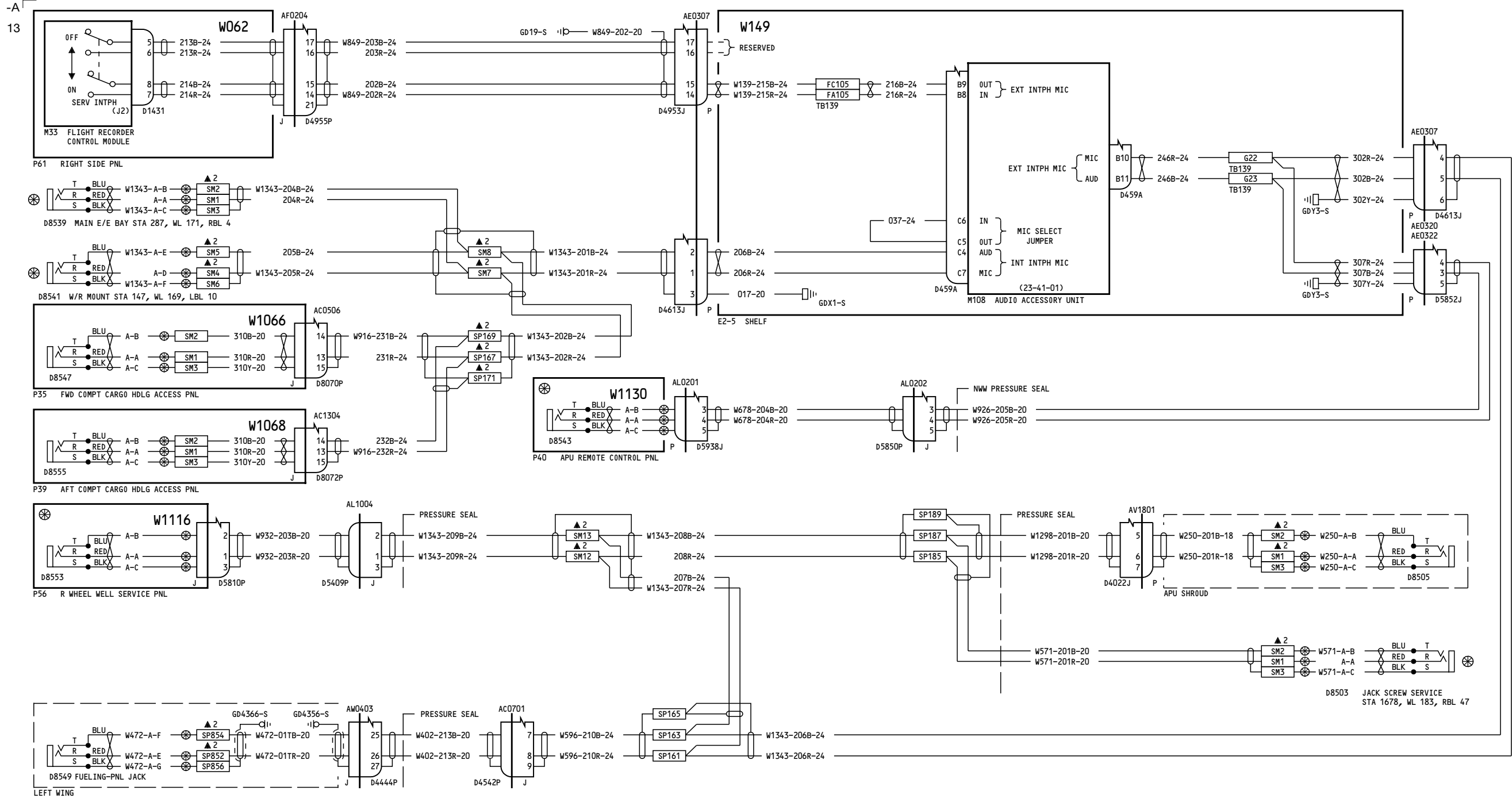

050-099, 155-157, 277-299

SERVICE INTERPHONE

23-41-11

Page 1

D280T132

Jan 21/2005

23-41-11

Page 1

Jan 21/2005

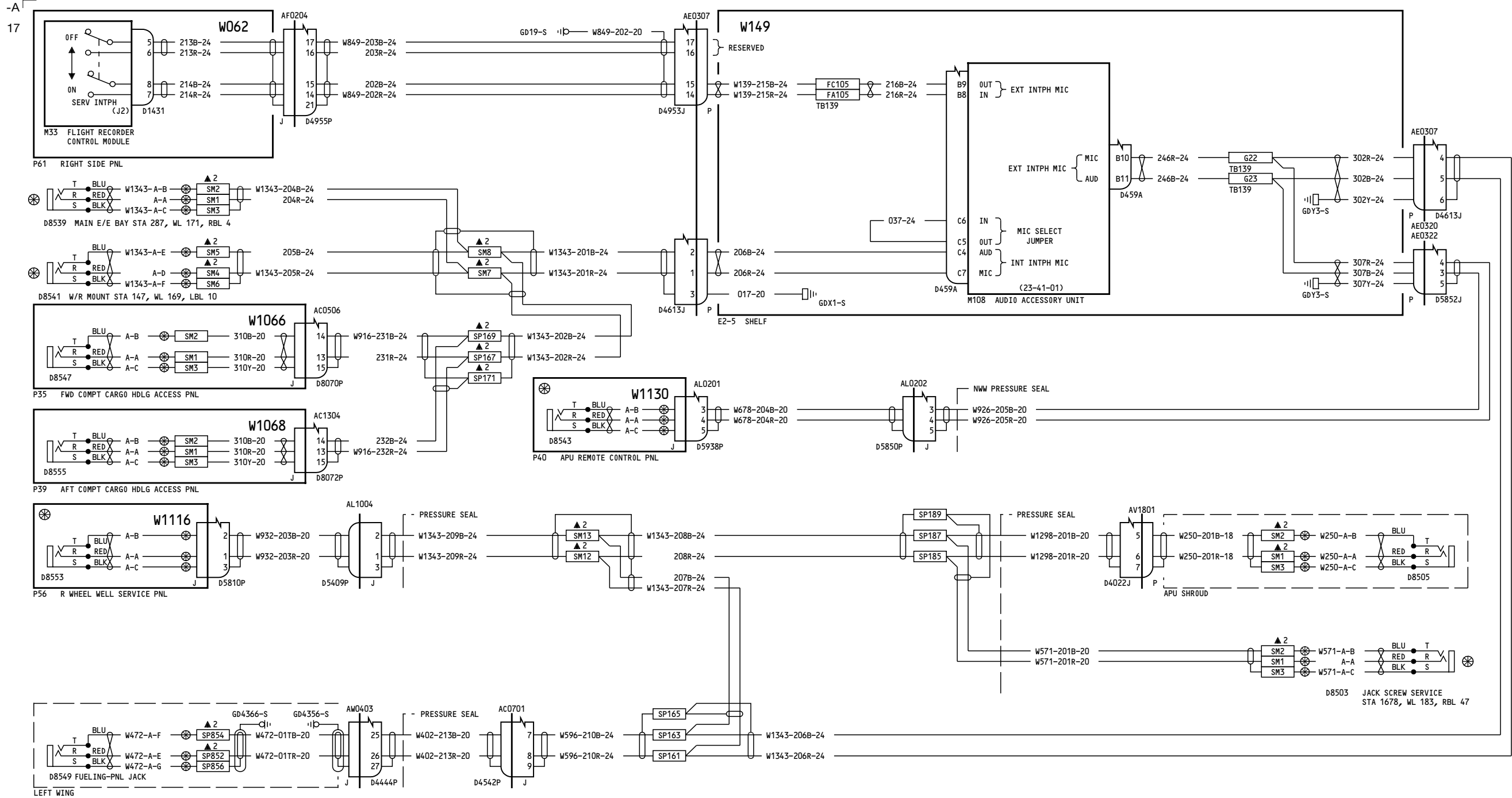

150-154

SERVICE INTERPHONE

23-41-11

Page 2

D280T132

Jan 21/2005

23-41-11

Page 2

Jan 21/2005

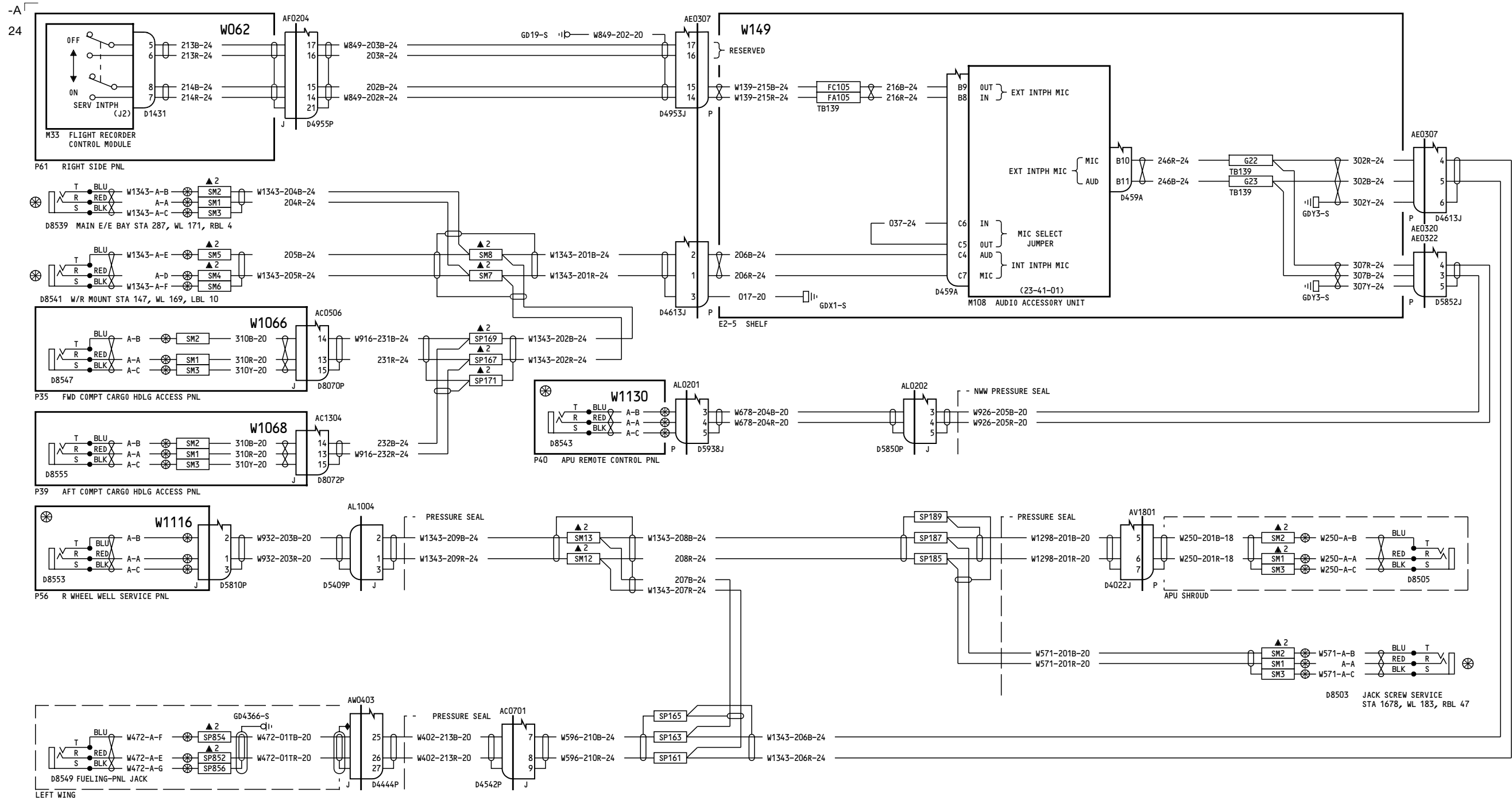

NOTES:
SHIELD PIGTAIL TO DISCONNECT BACKSHELL 2 INCH MAXIMUM

162-199

SERVICE INTERPHONE

23-41-11

Page 3

D280T132

Jan 21/2005

23-41-11

Page 3

Jan 21/2005

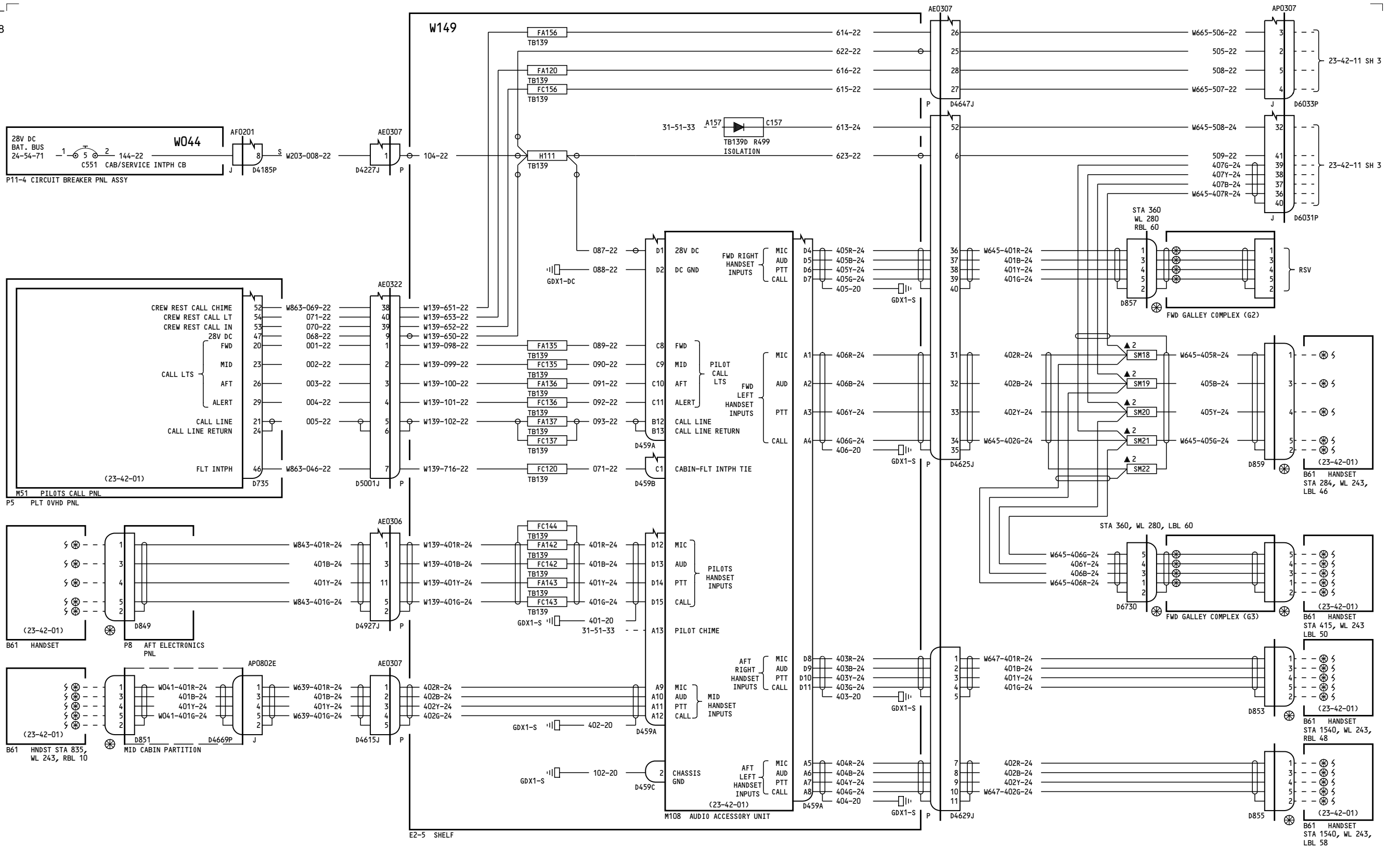

050-051

CABIN INTERPHONE SYSTEM

23-42-11

Page 1A
Sheet 1
Jan 21/2005

D280T132

23-42-11

Incorporates
MTO 230540

23-42-11

Page 1A
Sheet 1
Jan 21/2005

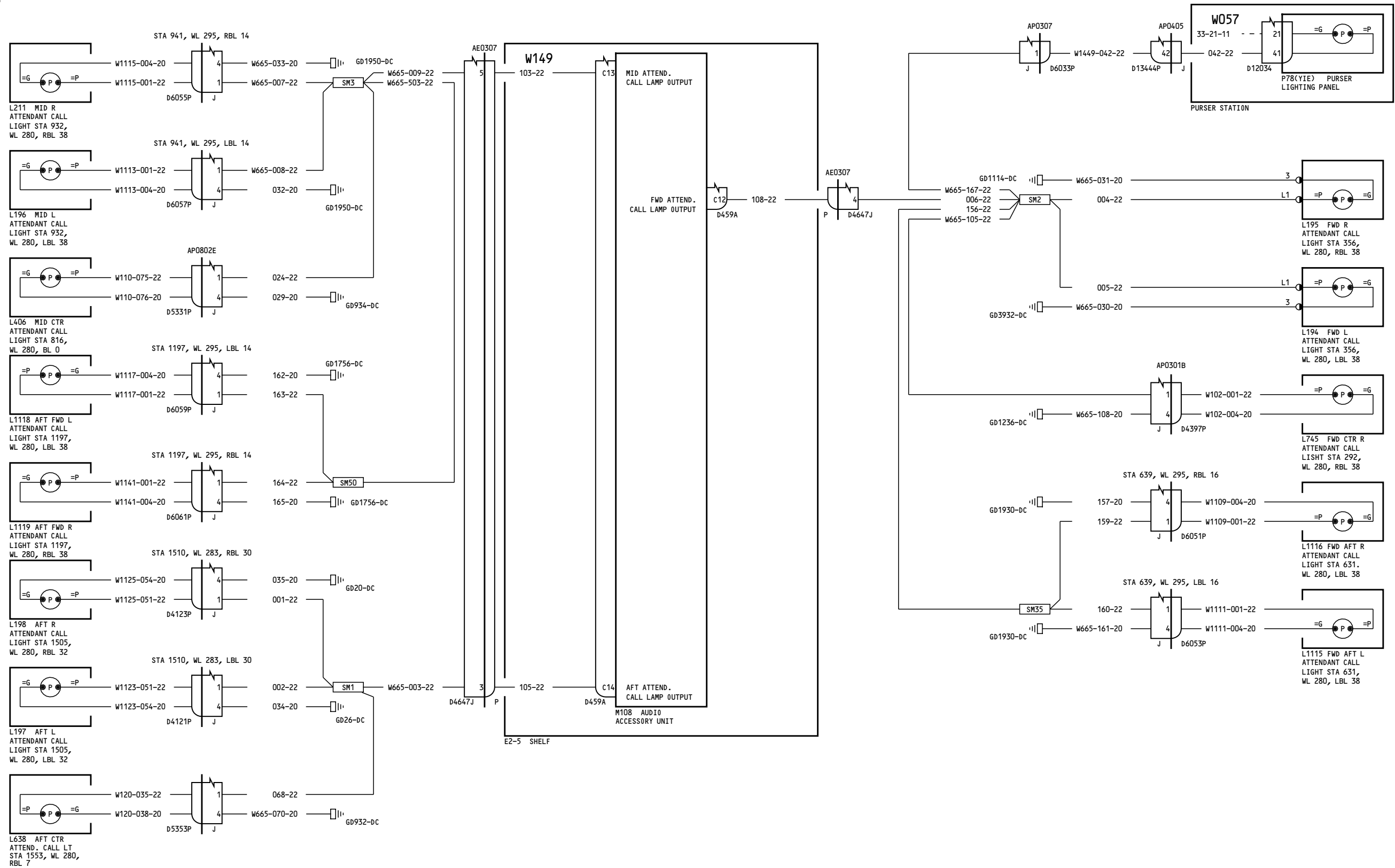

050-051

CABIN INTERPHONE SYSTEM

23-42-11

Page 1A
Sheet 2
Jan 21/2005

D280T132

23-42-11

Page 1A
Sheet 2
Jan 21/2005

83

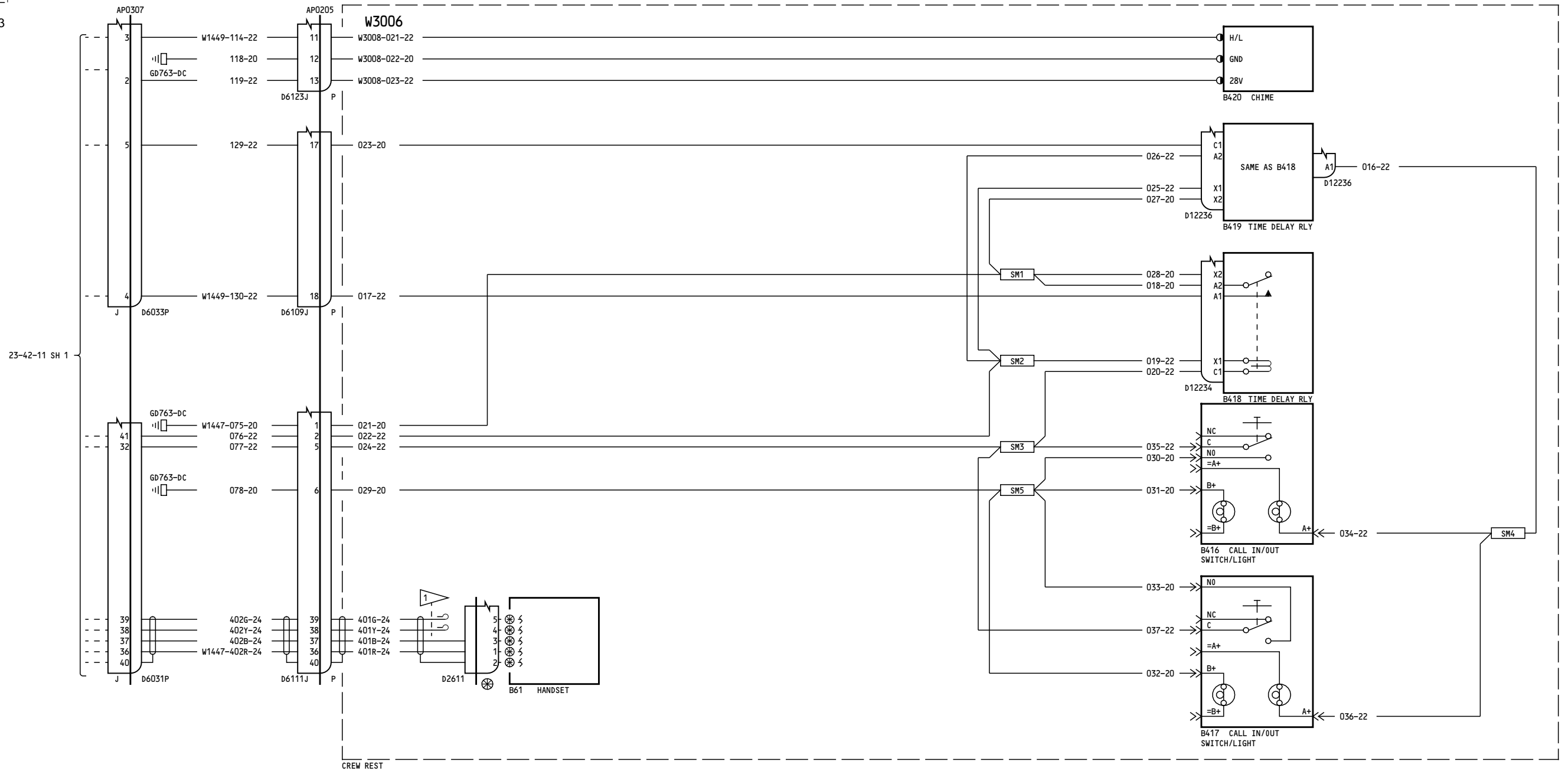

NOTES:
 1 CAP & STOW NEAR D2611

050-051

CABIN INTERPHONE SYSTEM

D280T132

23-42-11

Page 1A
 Sheet 3
 Jan 21/2005

23-42-11

Page 1A
 Sheet 3
 Jan 21/2005

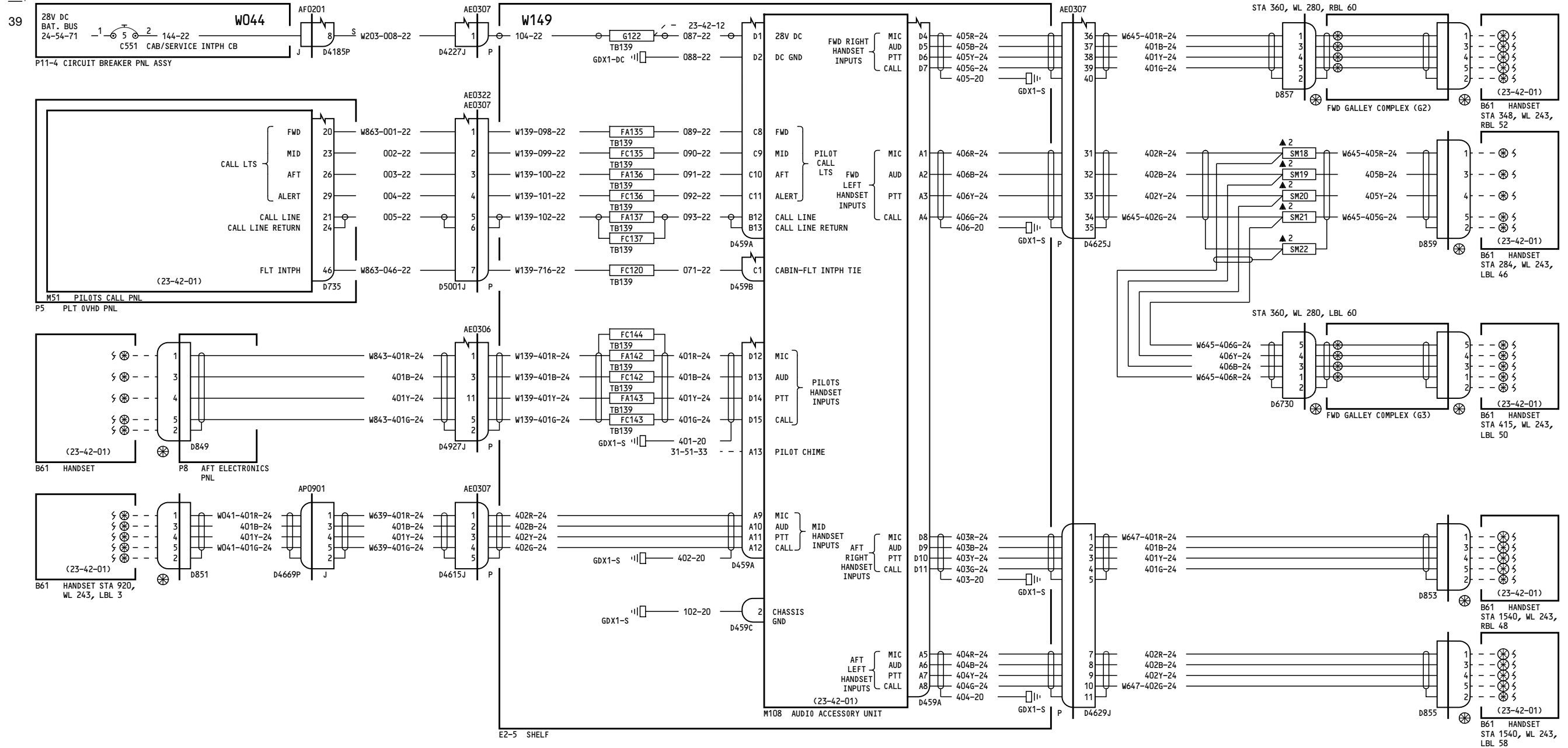

150

CABIN INTERPHONE SYSTEM

D280T132

23-42-11

Page 2
Sheet 1
Jan 21/2005

23-42-11

Page 2
Sheet 1
Jan 21/2005

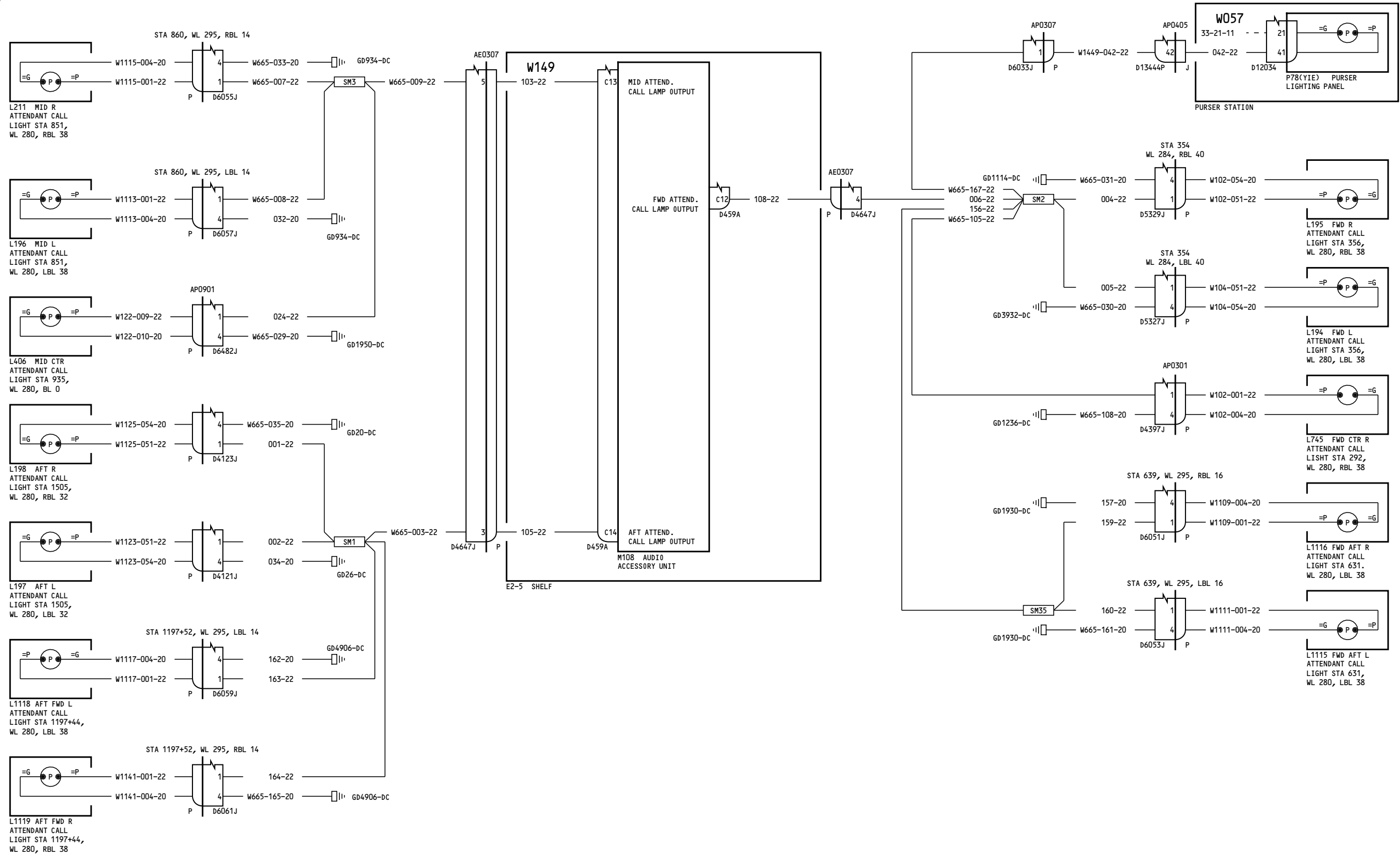

150

CABIN INTERPHONE SYSTEM
D280T132

23-42-11

Page 2
Sheet 2
Jan 21/2005

23-42-11

Page 2
Sheet 2
Jan 21/2005

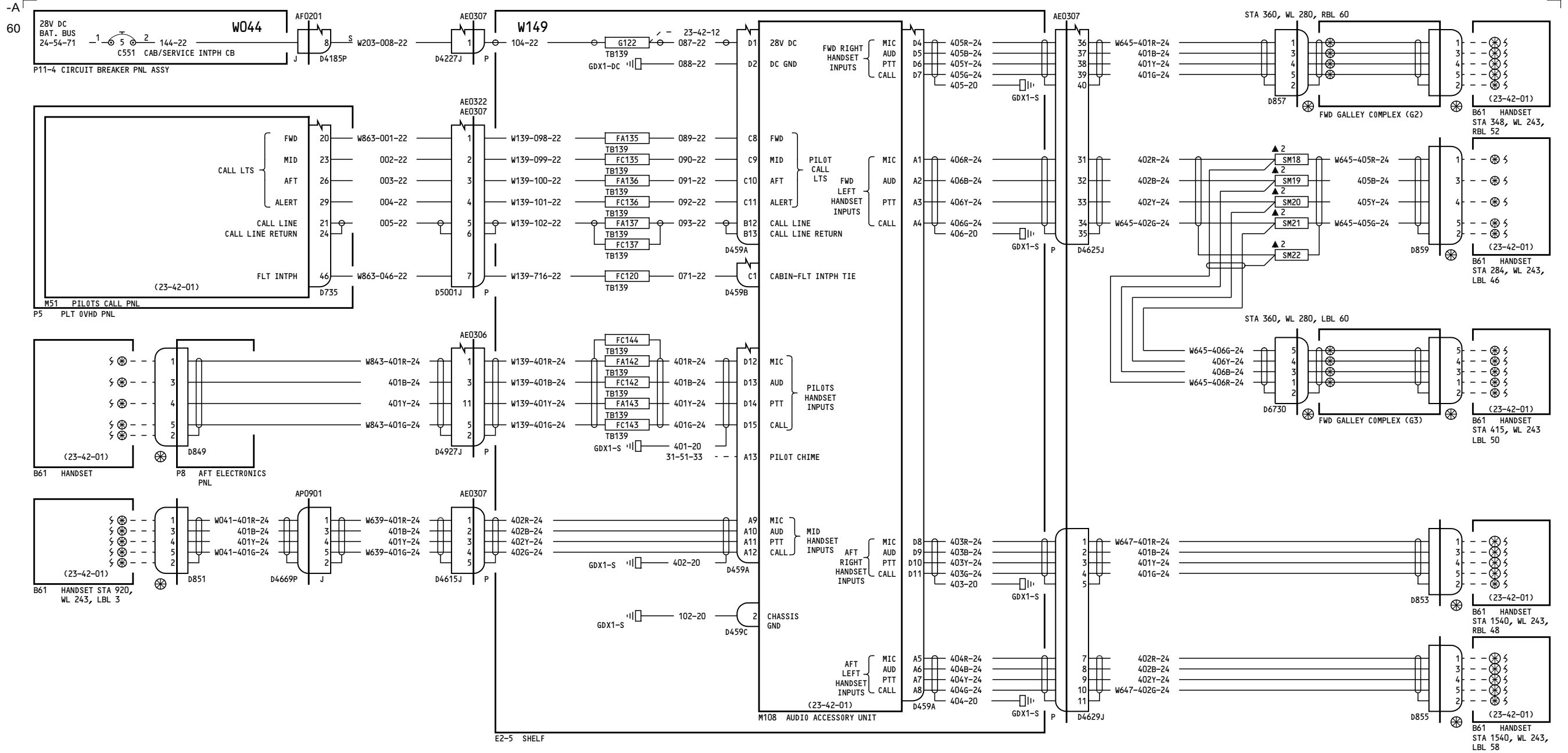

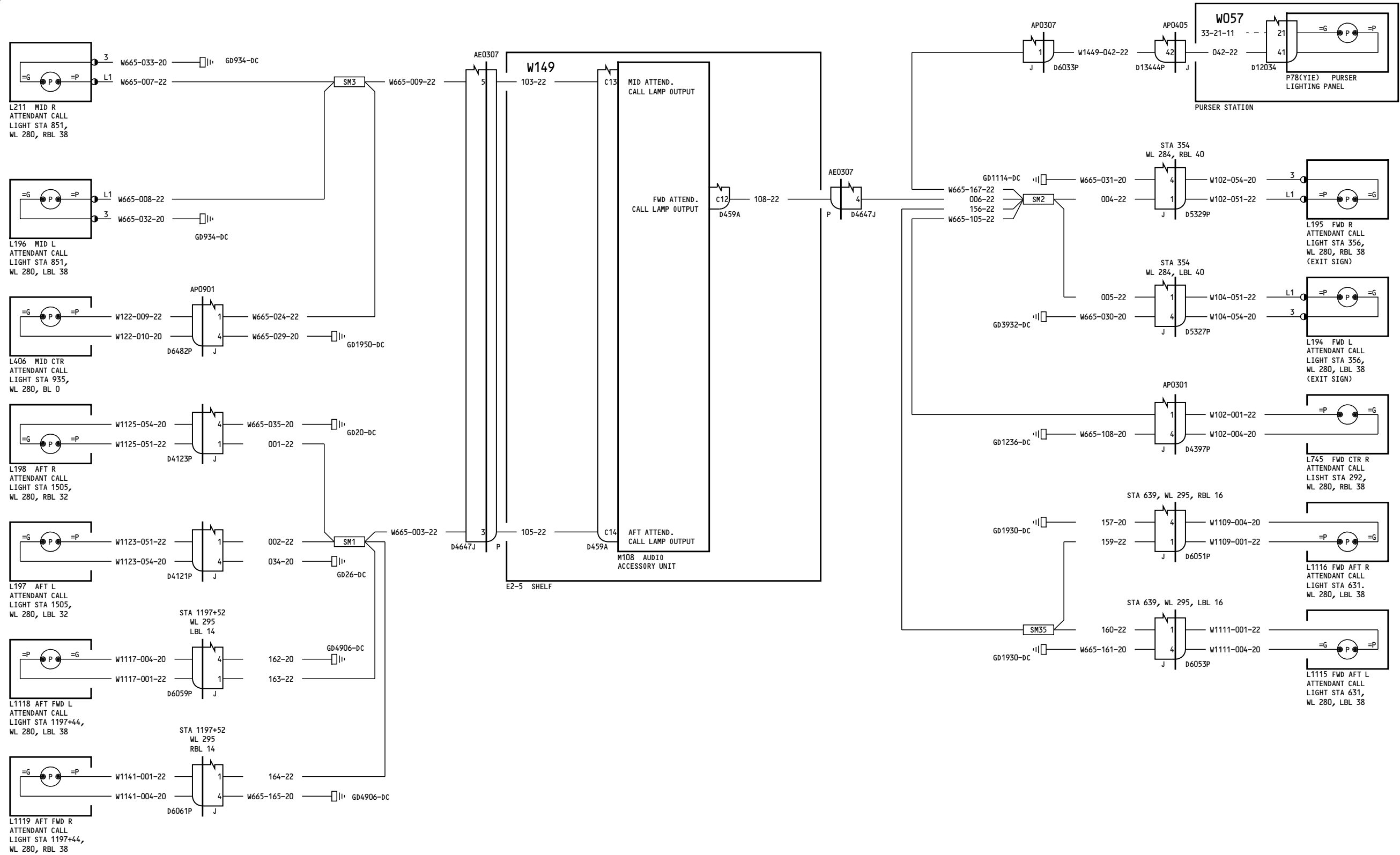

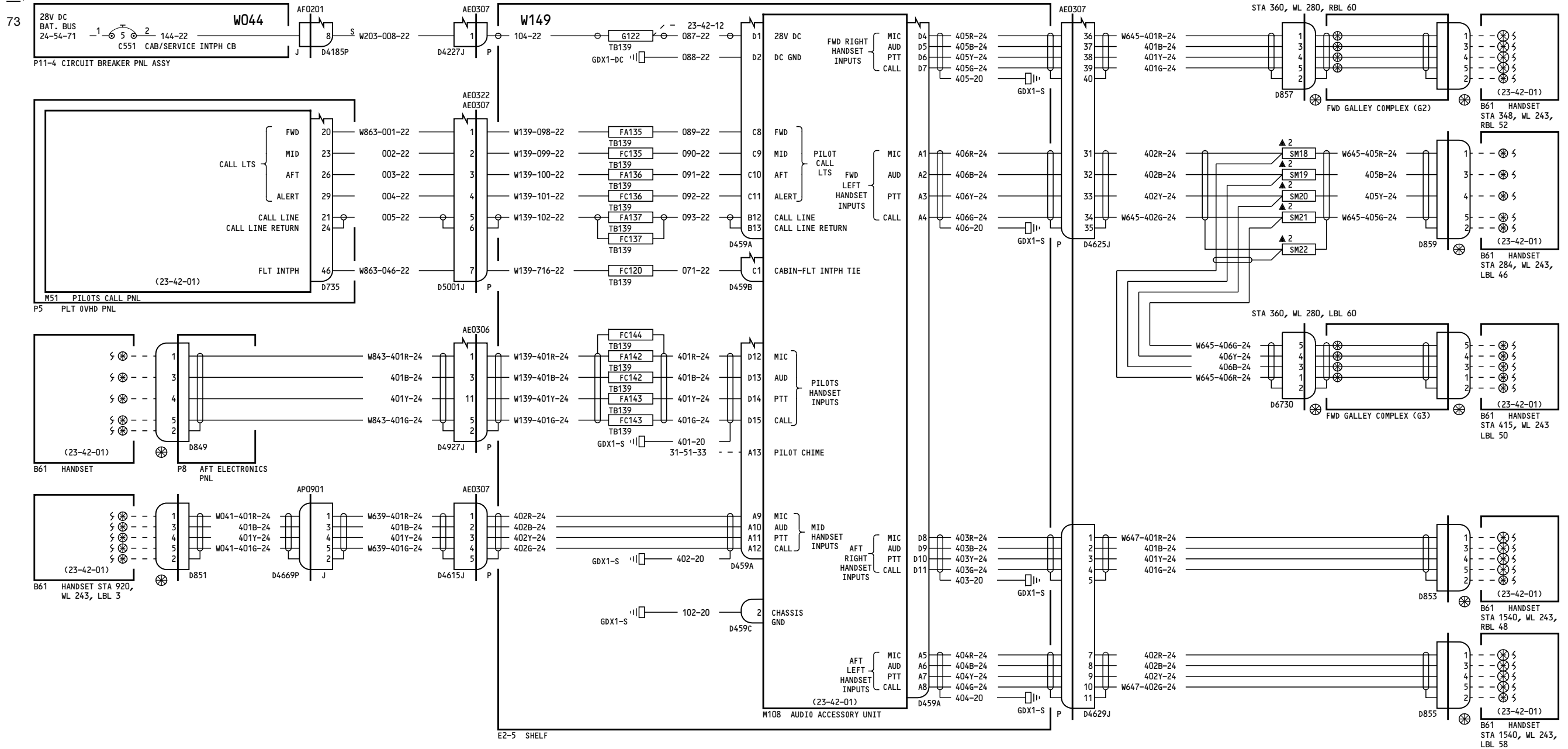

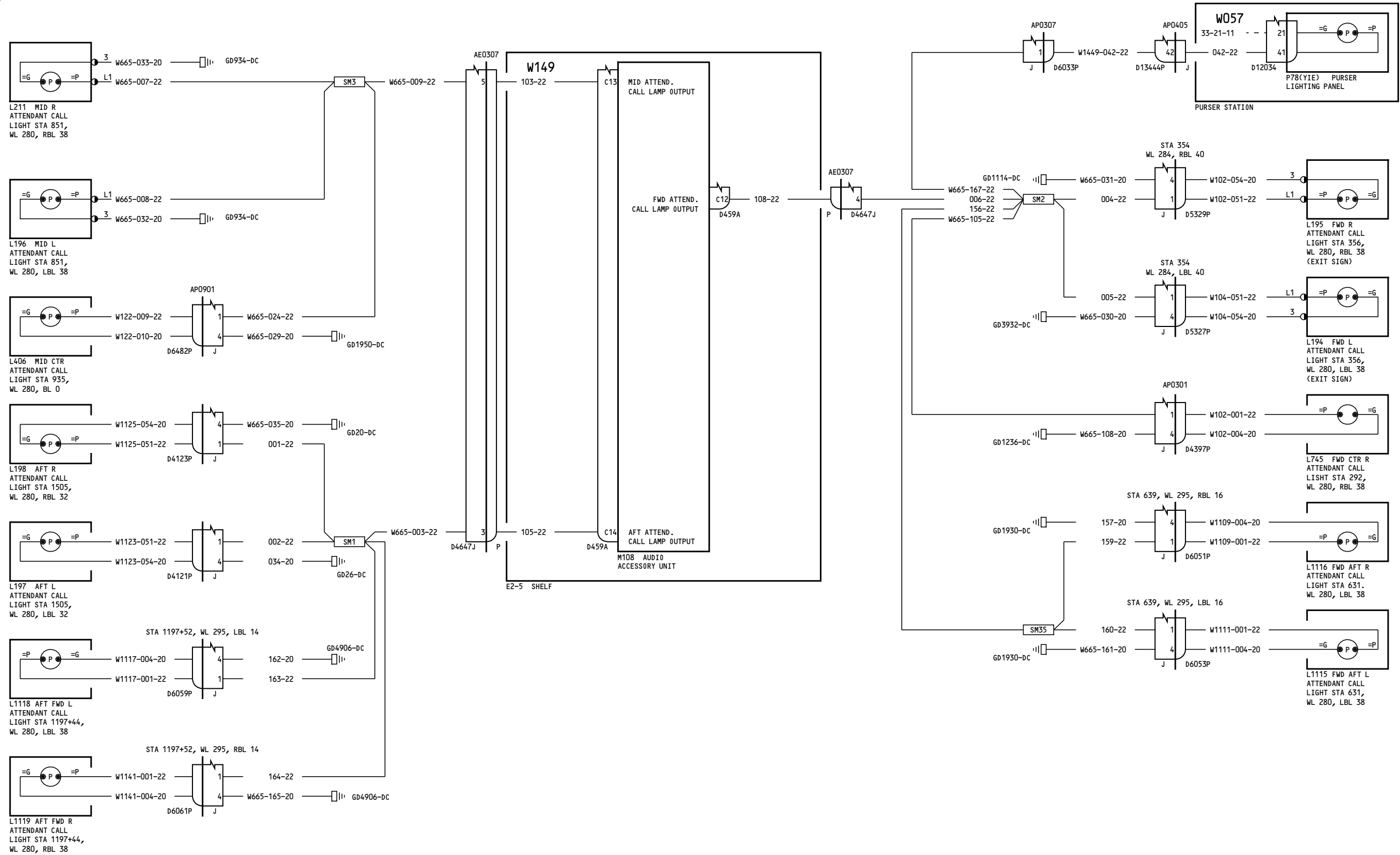

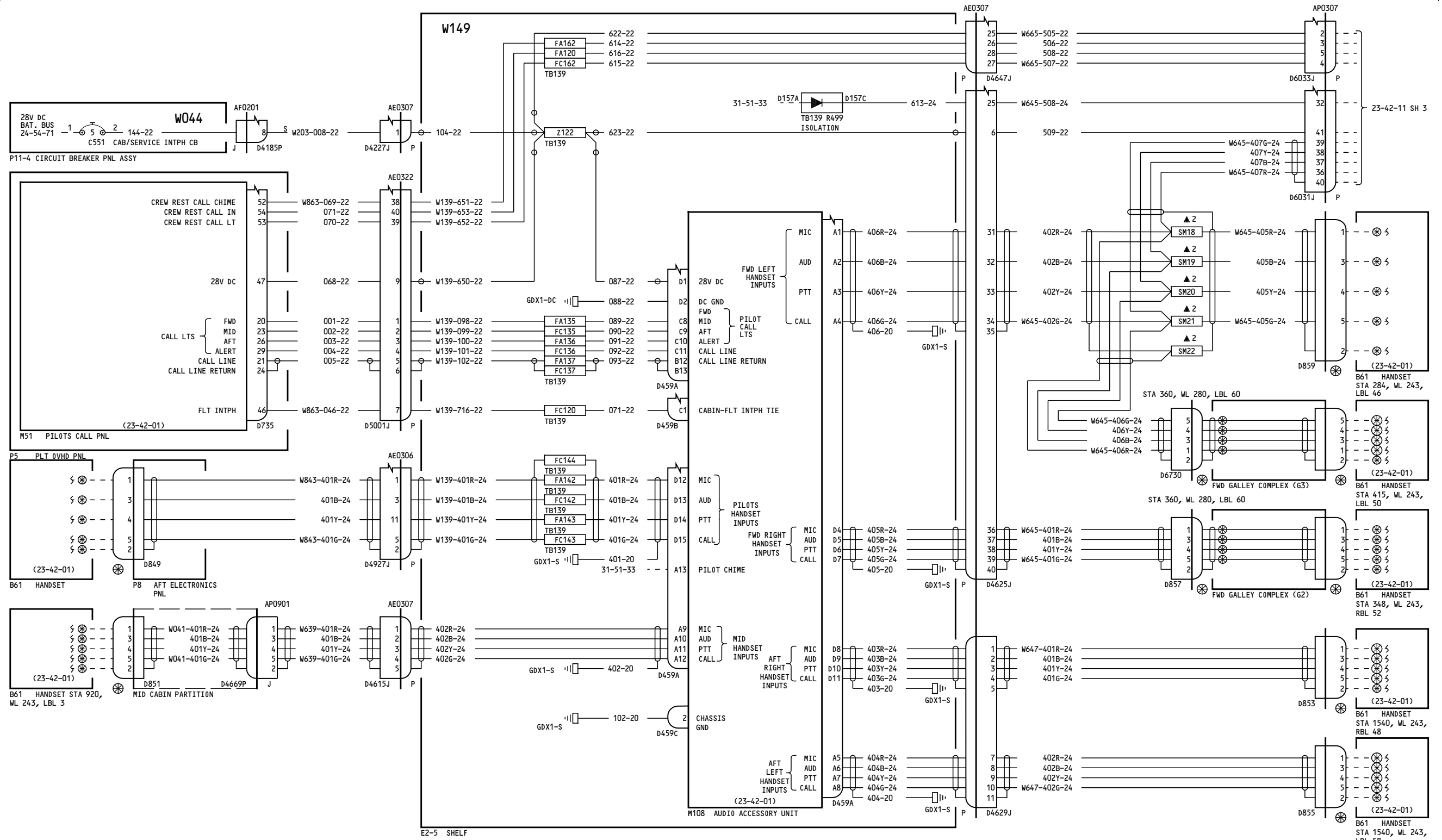

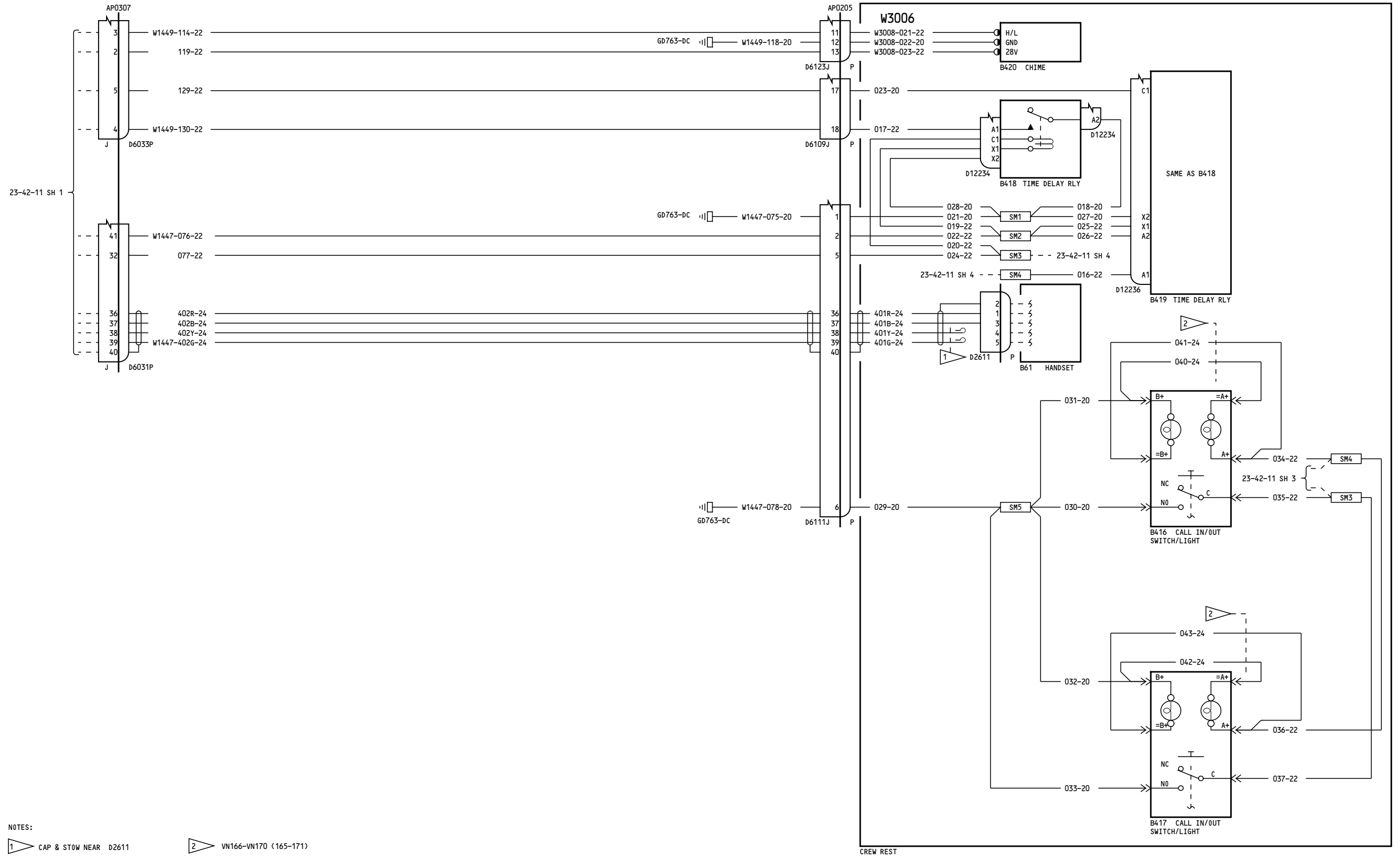

NOTES:
 1 CAP & STOW NEAR D2611
 2 VN166-VN170 (165-171)

162-199

CABIN INTERPHONE SYSTEM

23-42-11

Page 6
Sheet 3
Jan 21/2005

D280T132

23-42-11

Page 6
Sheet 3
Jan 21/2005

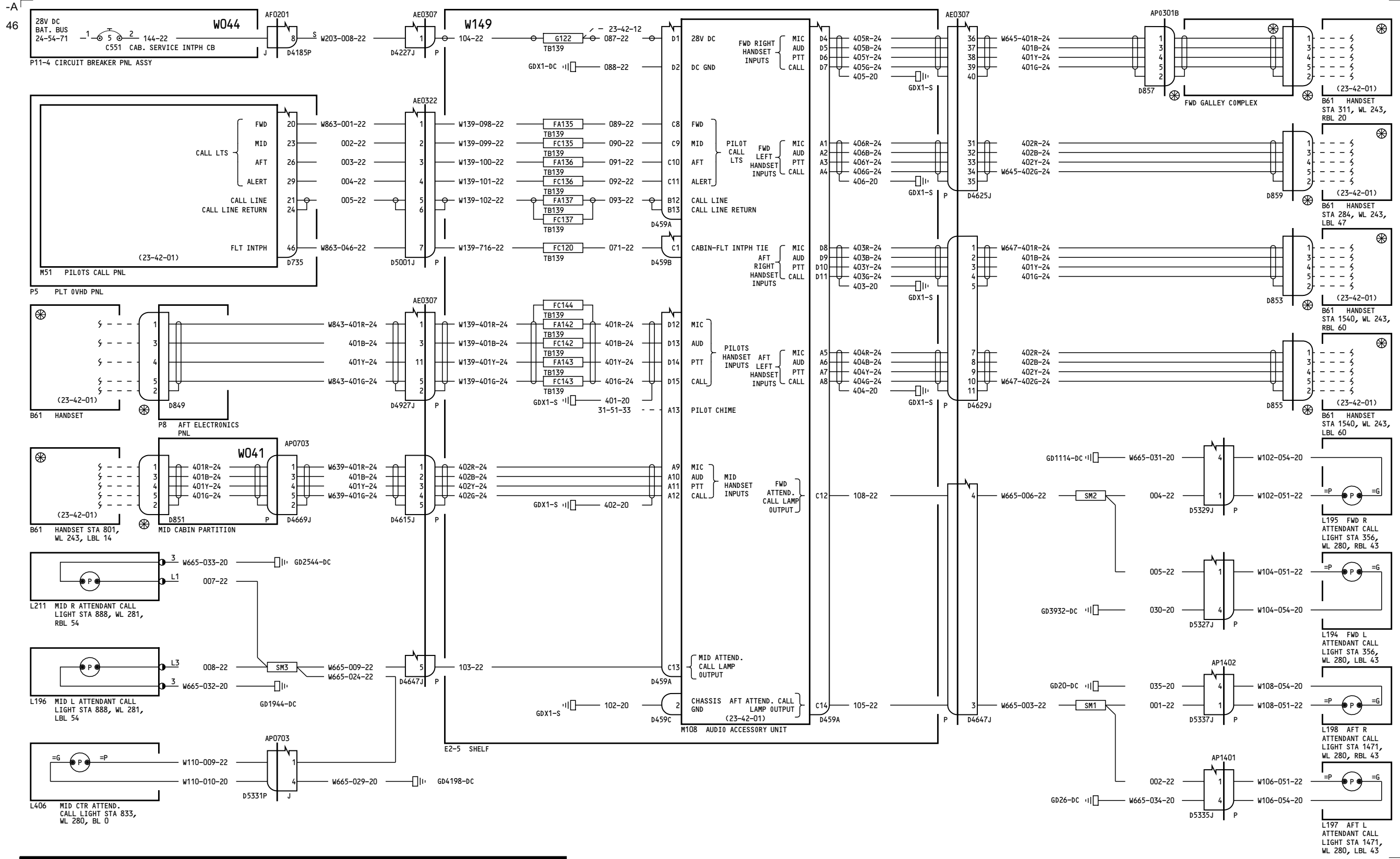

275-276

CABIN INTERPHONE SYSTEM

D280T132

23-42-11

Page 7

Jan 21/2005

23-42-11

Page 7

Jan 21/2005

139

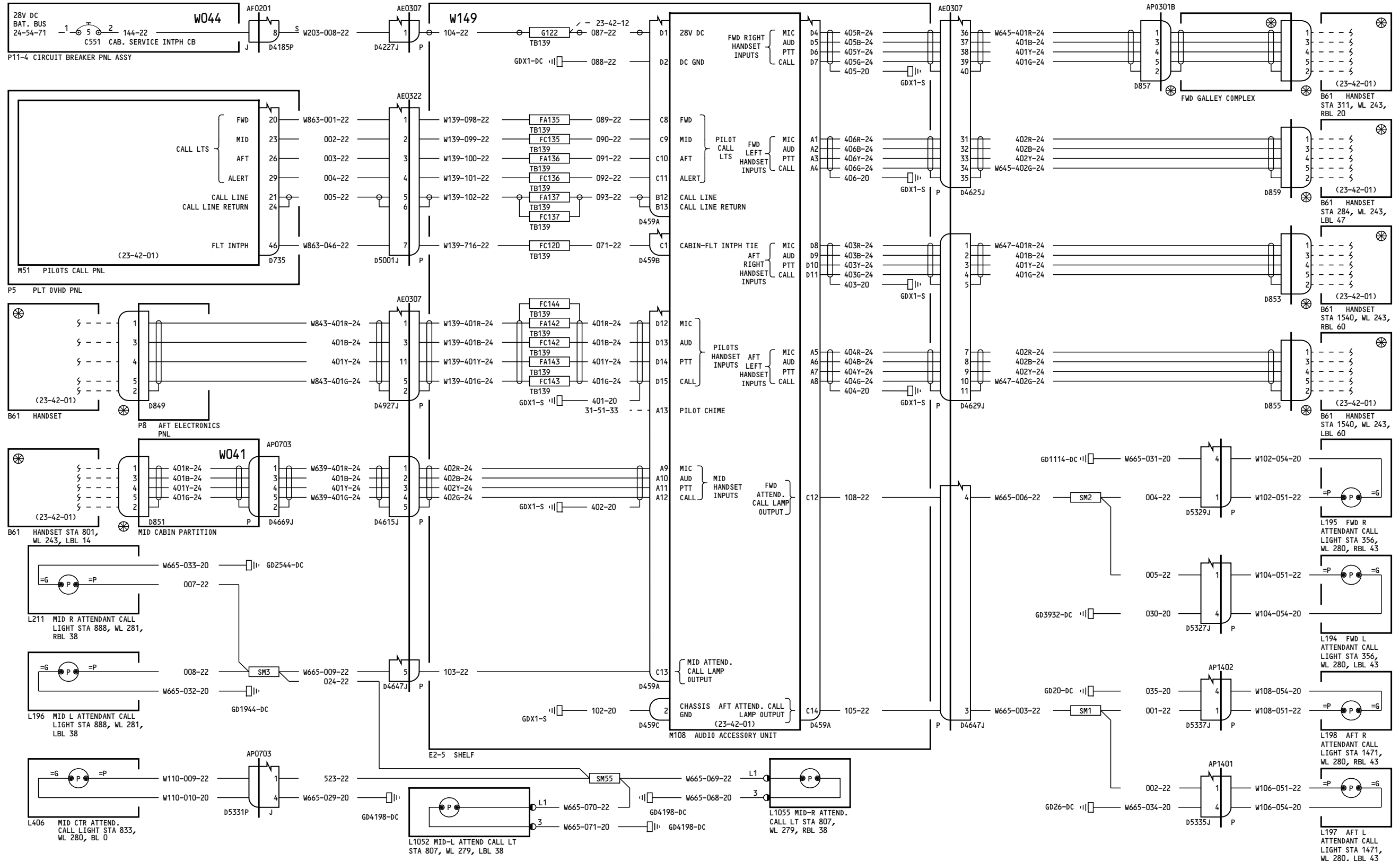

275-276

CABIN INTERPHONE SYSTEM

D280T132

23-42-11

Page 7.1
Jan 21/2005

Incorporates
33-0042

23-42-11

Page 7.1
Jan 21/2005

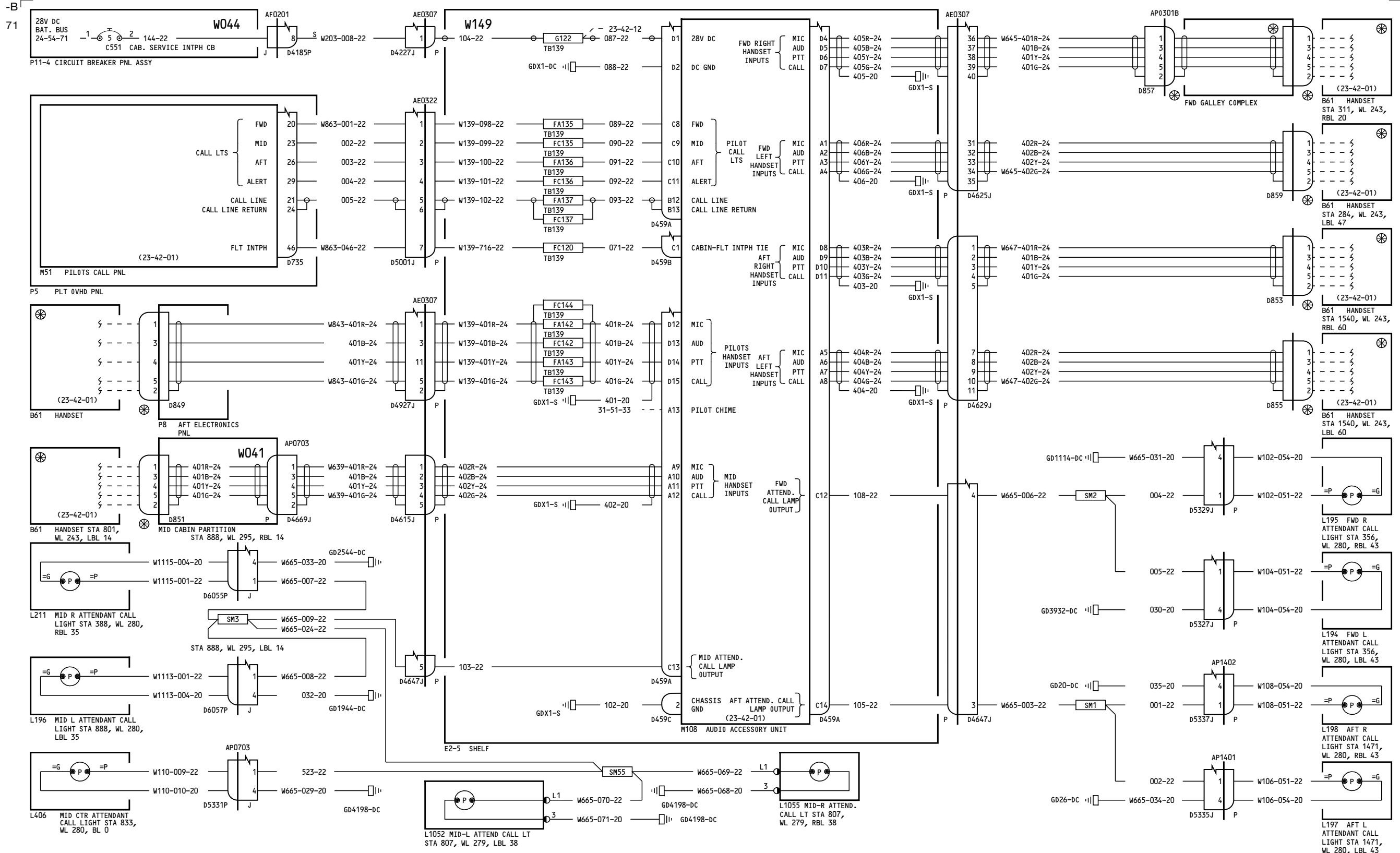

277-278

CABIN INTERPHONE SYSTEM

23-42-11

Page 8

D280T132

Jan 21/2005

23-42-11

Page 8

Jan 21/2005

BOEING PROPRIETARY - Copyright © - Unpublished Work - See title page for details.

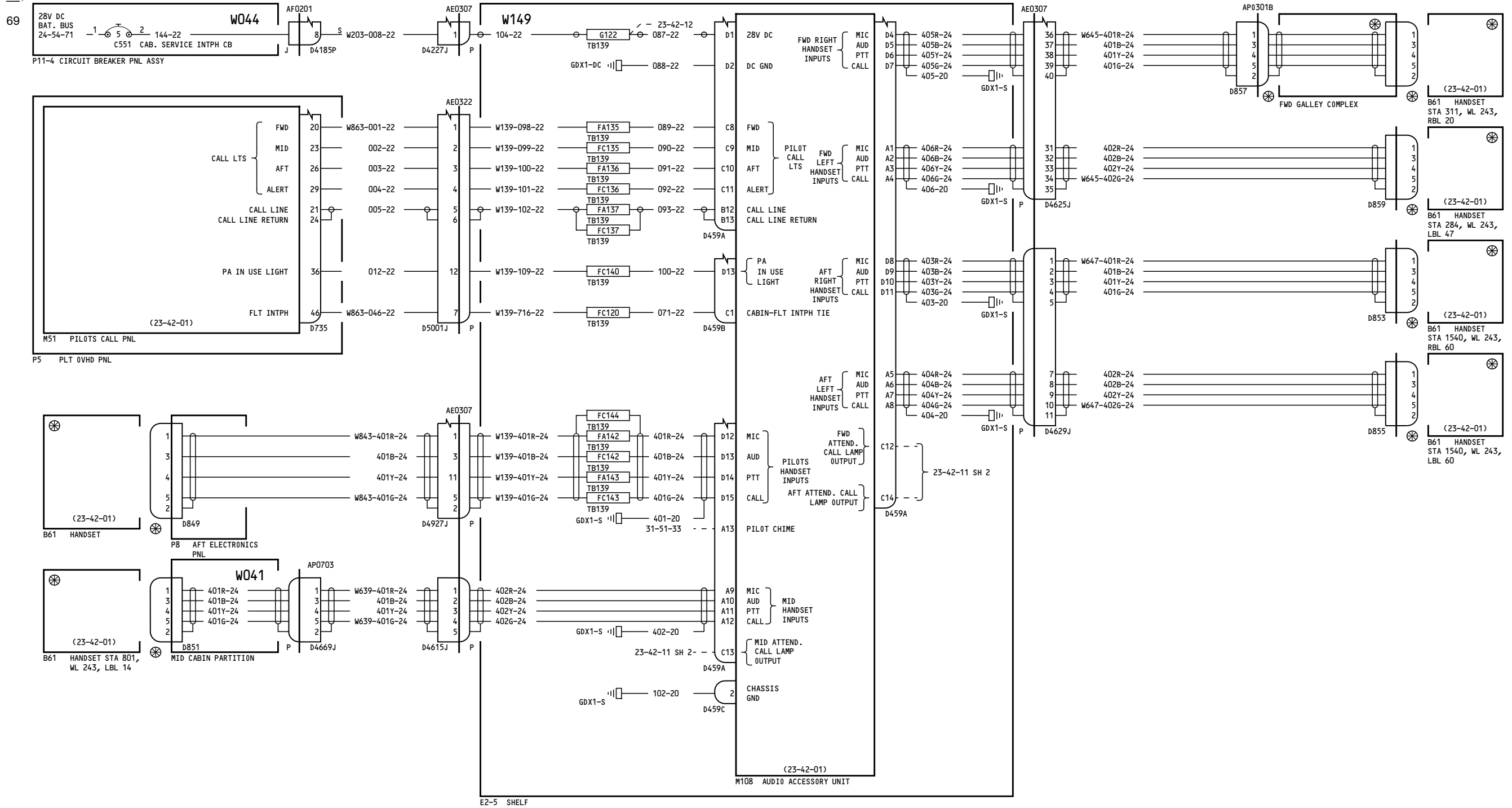

280-299

CABIN INTERPHONE SYSTEM

23-42-11

Page 9
Sheet 1
Jan 21/2005

D280T132

23-42-11

Page 9
Sheet 1
Jan 21/2005

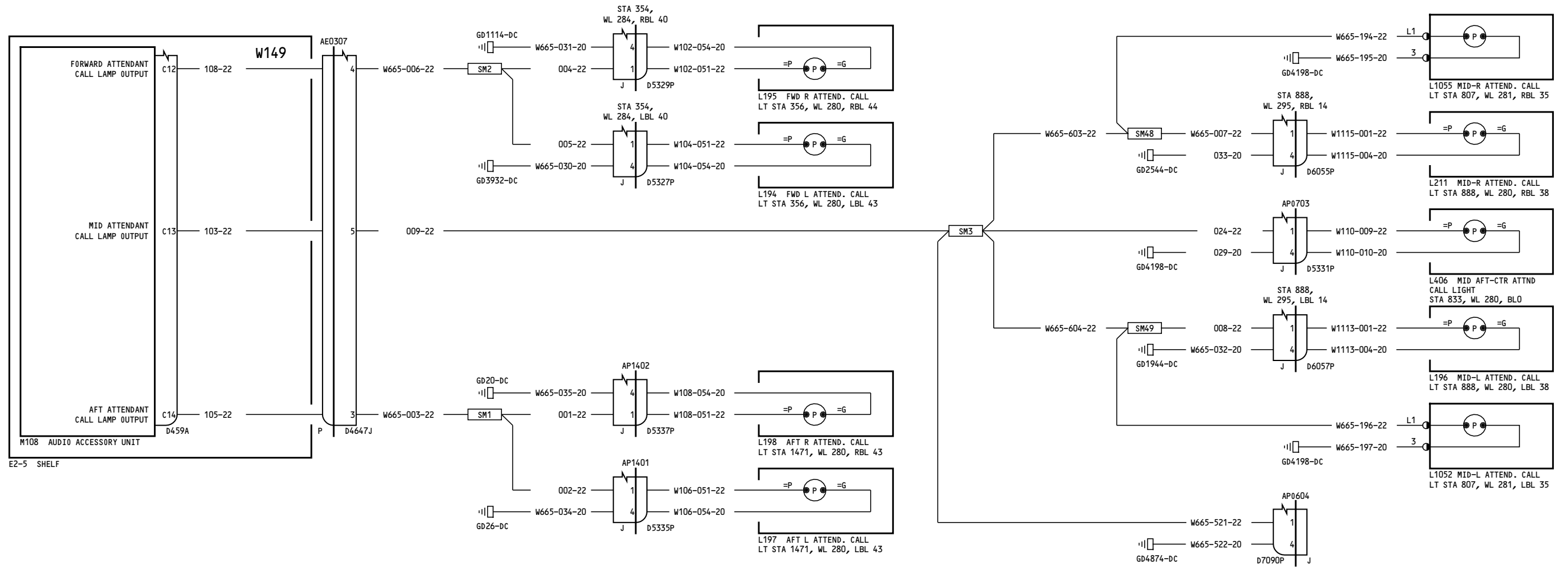

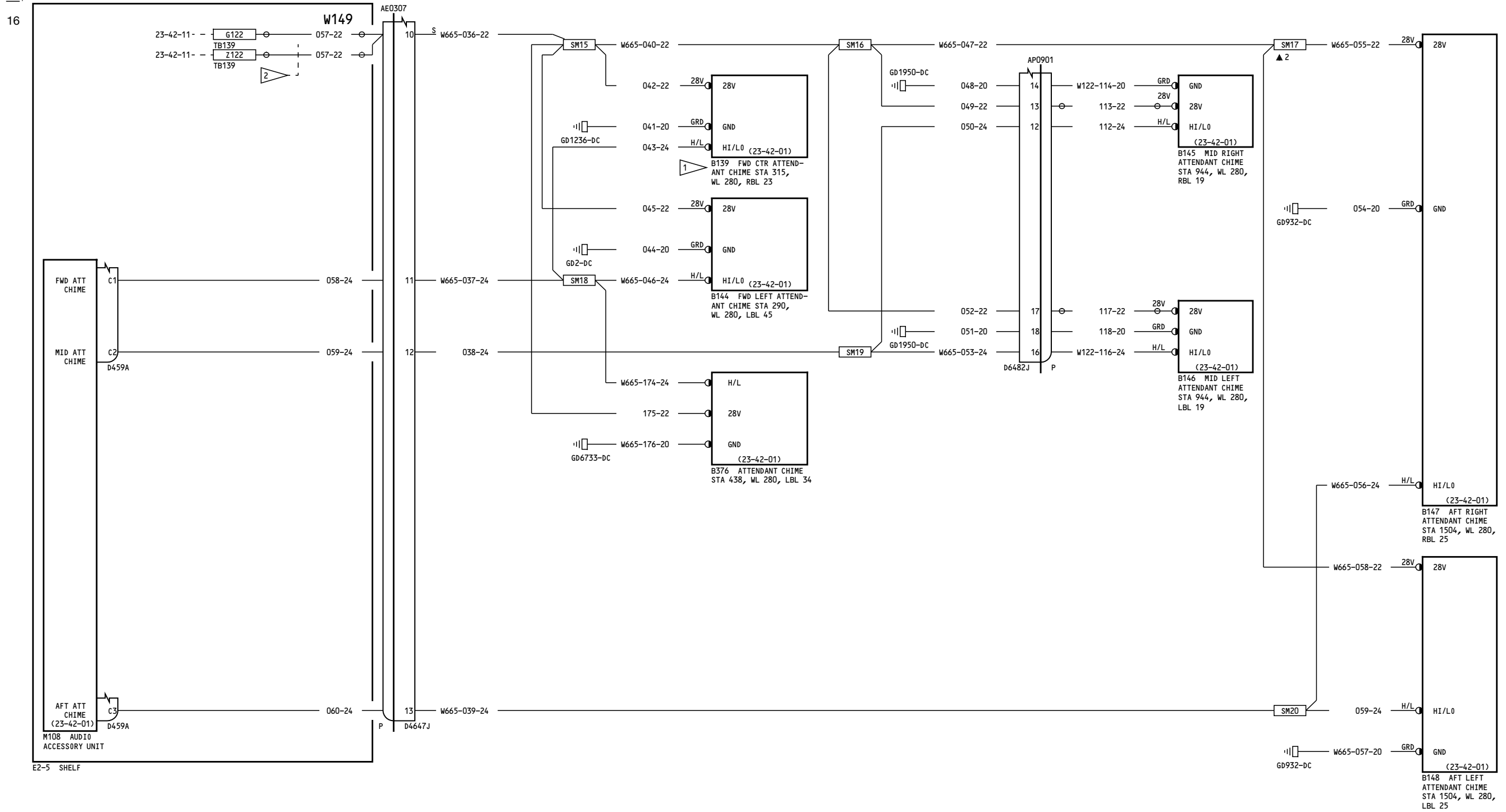

- NOTES:
- 1 B139 IS AT STA 325 FOR VN163-VN170
 - 2 VN163-VN170

150-199

CABIN INTERPHONE SYSTEM-
ELECTRONIC CHIME

23-42-12

Page 1

Jan 21/2005

D280T132

23-42-12

Page 1

Jan 21/2005

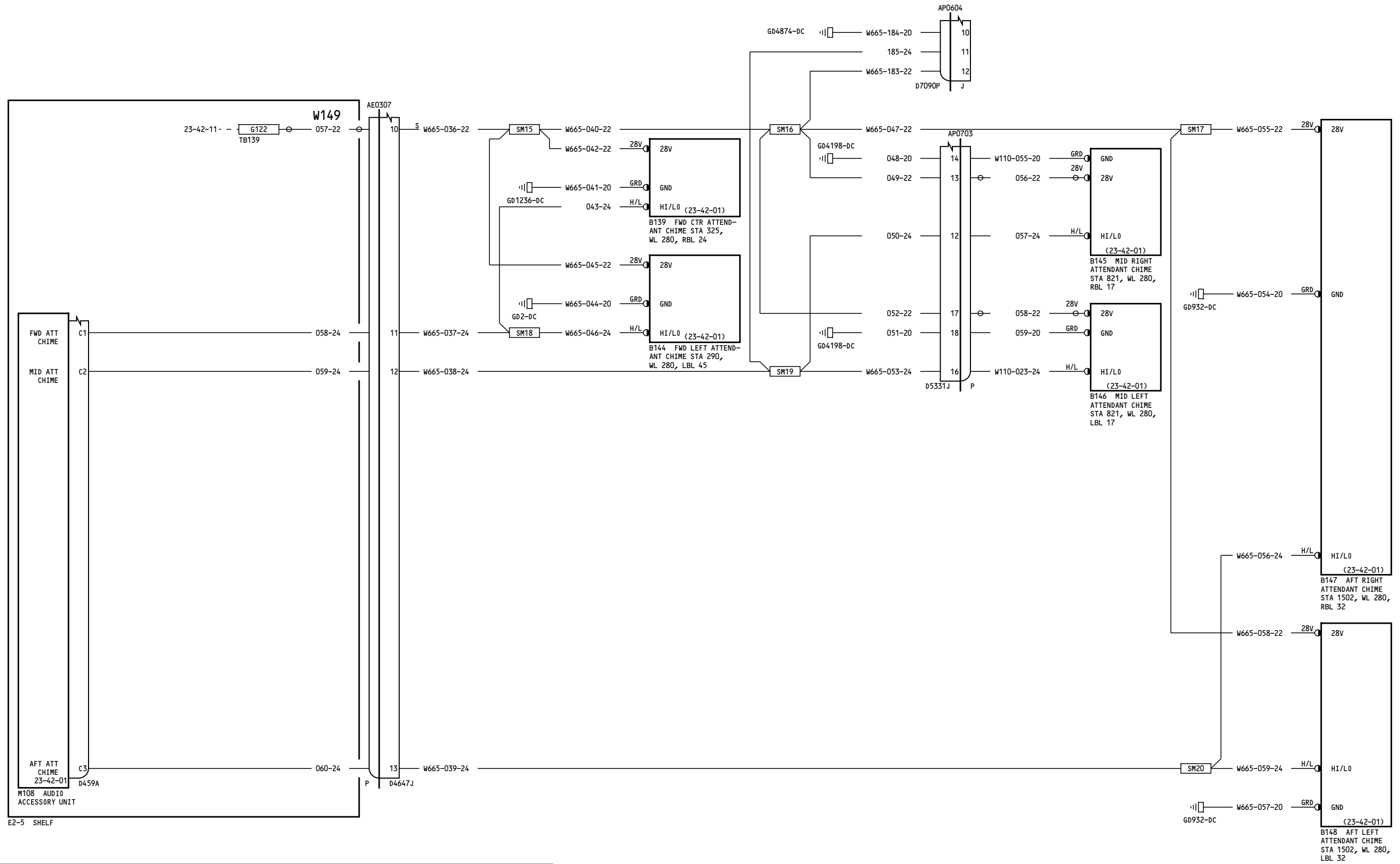

280-299

**CABIN INTERPHONE SYSTEM-
ELECTRONIC CHIME**

D280T132

23-42-12

Page 3

Jan 21/2005

23-42-12

Page 3

Jan 21/2005

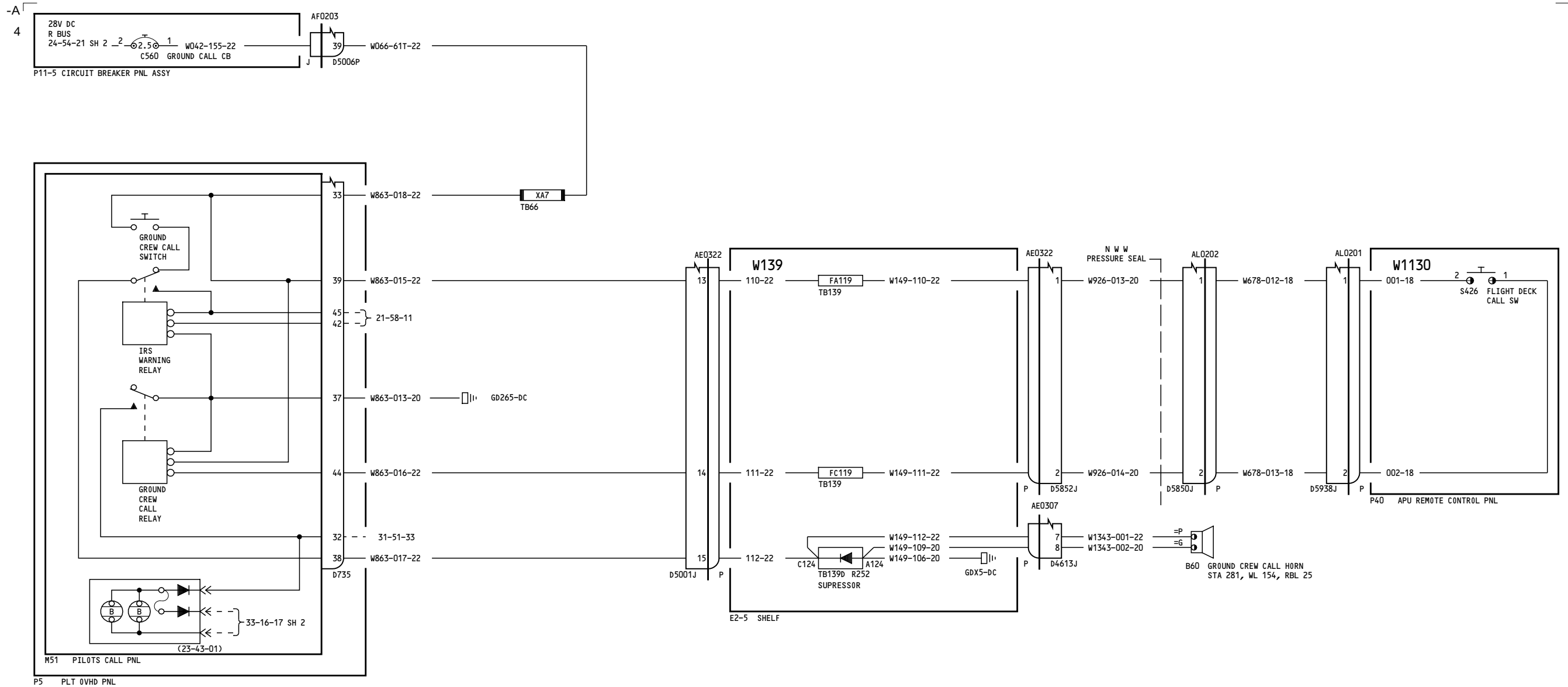

050-099, 155-199, 277-299	GROUND CREW CALL D280T132
---------------------------	-----------------------------------------

23-43-11

Page 1

Jan 21/2005

23-43-11

Page 1

Jan 21/2005

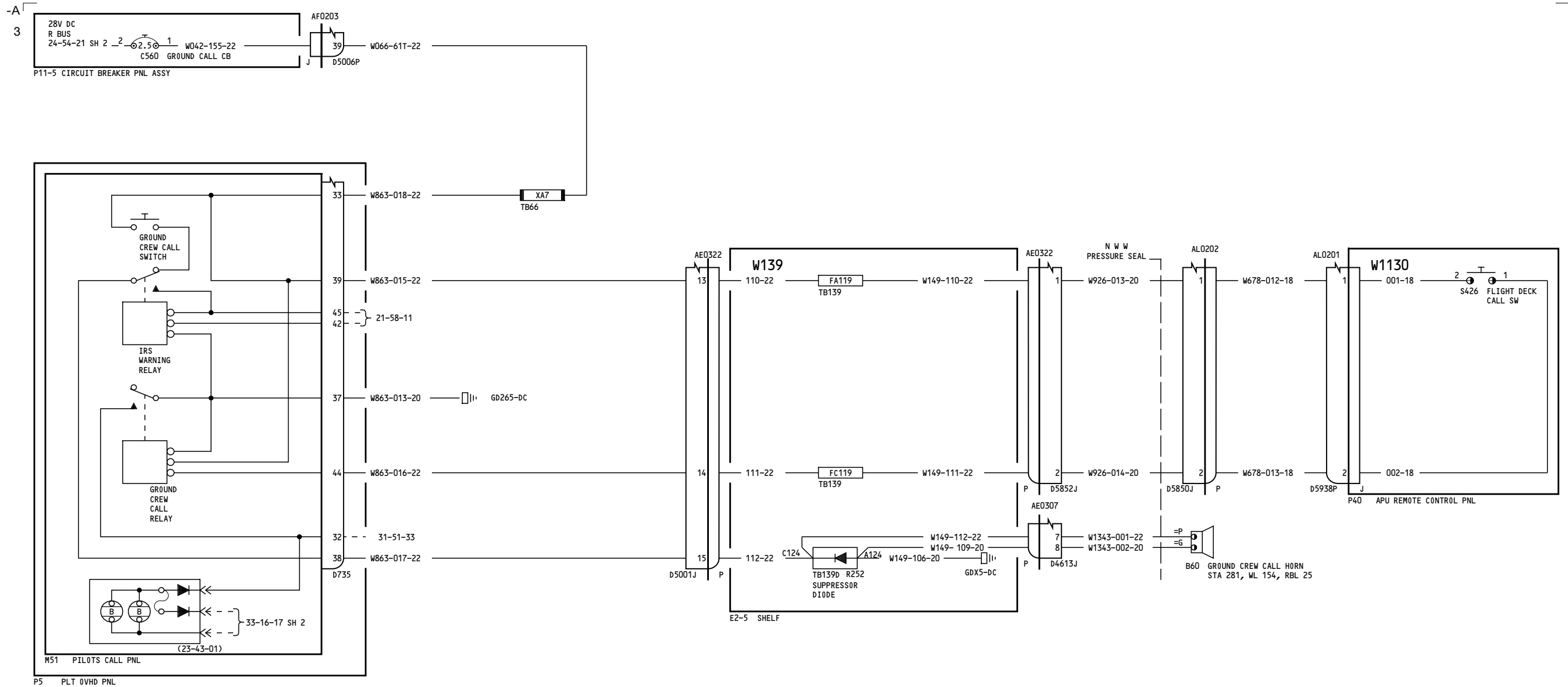

150-154	GROUND CREW CALL
D280T132	

23-43-11

Page 2

Jan 21/2005

23-43-11

Page 2

Jan 21/2005

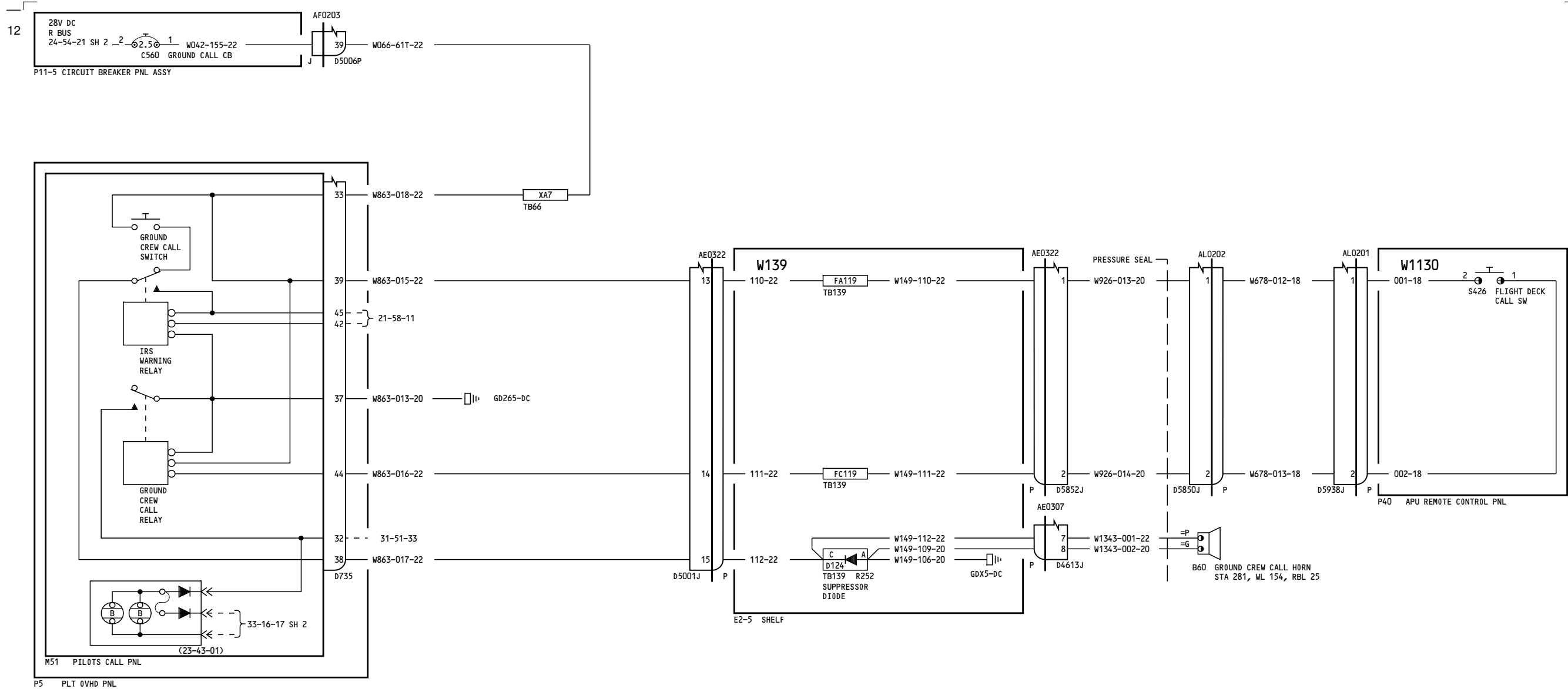

275-276

GROUND CREW CALL

23-43-11

Page 3.1

Jan 21/2005

D280T132

Incorporates
 32-0085

23-43-11

Page 3.1

Jan 21/2005

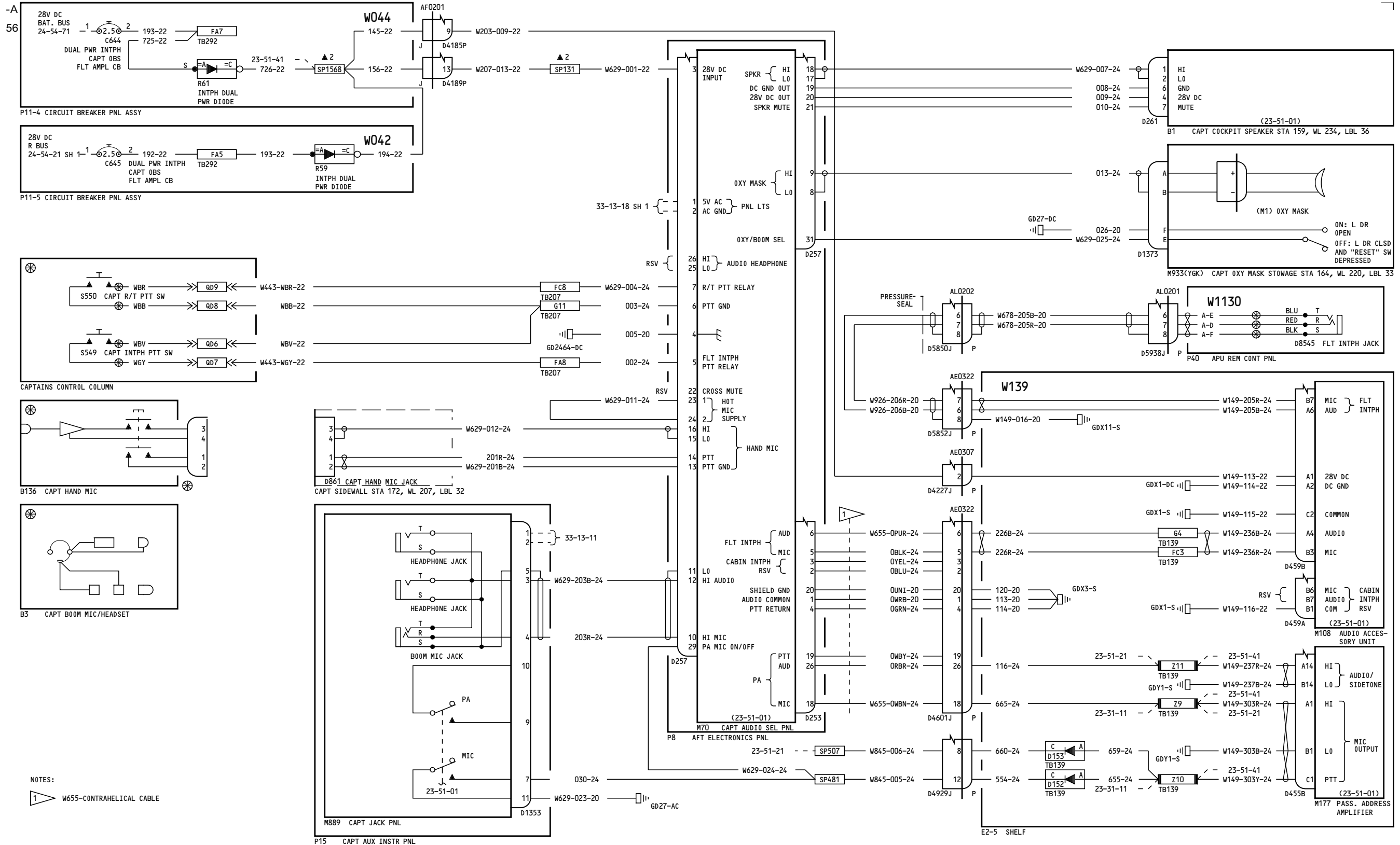

NOTES:
 W655-CONTRAHELICAL CABLE

050-099, 155-199

FLIGHT INTERPHONE-CAPTAIN-PART A

23-51-11

Page 1

D280T132

Jan 21/2005

23-51-11

Page 1

Jan 21/2005

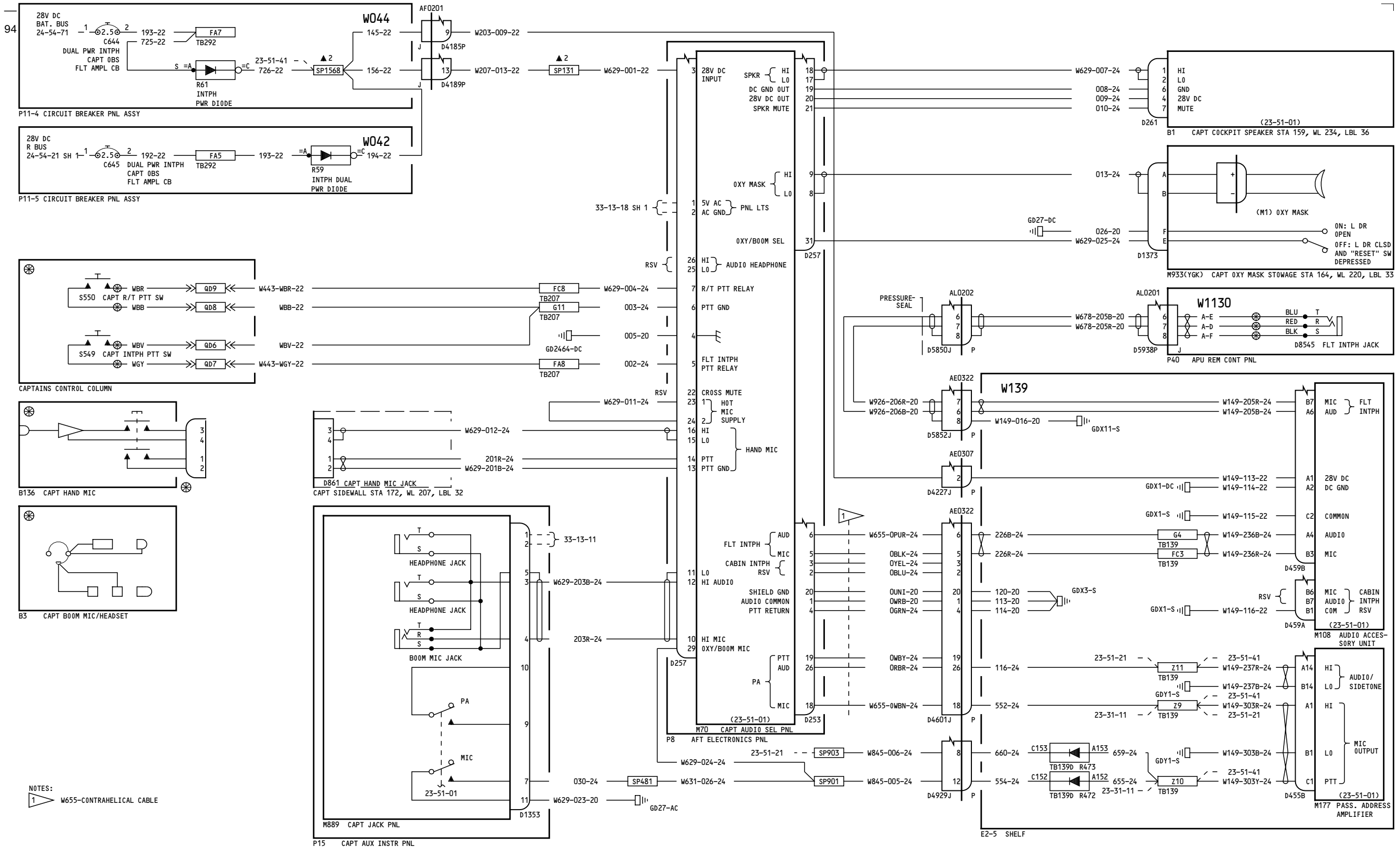

NOTES:
 1 W655-CONTRAHELICAL CABLE

**FLIGHT INTERPHONE-
CAPTAIN-
PART A**

23-51-11

Page 2.1A

D280T132

Jan 21/2005

Incorporates
 23-0032 R01
 ATA 23/9/90

23-51-11

Page 2.1A

Jan 21/2005

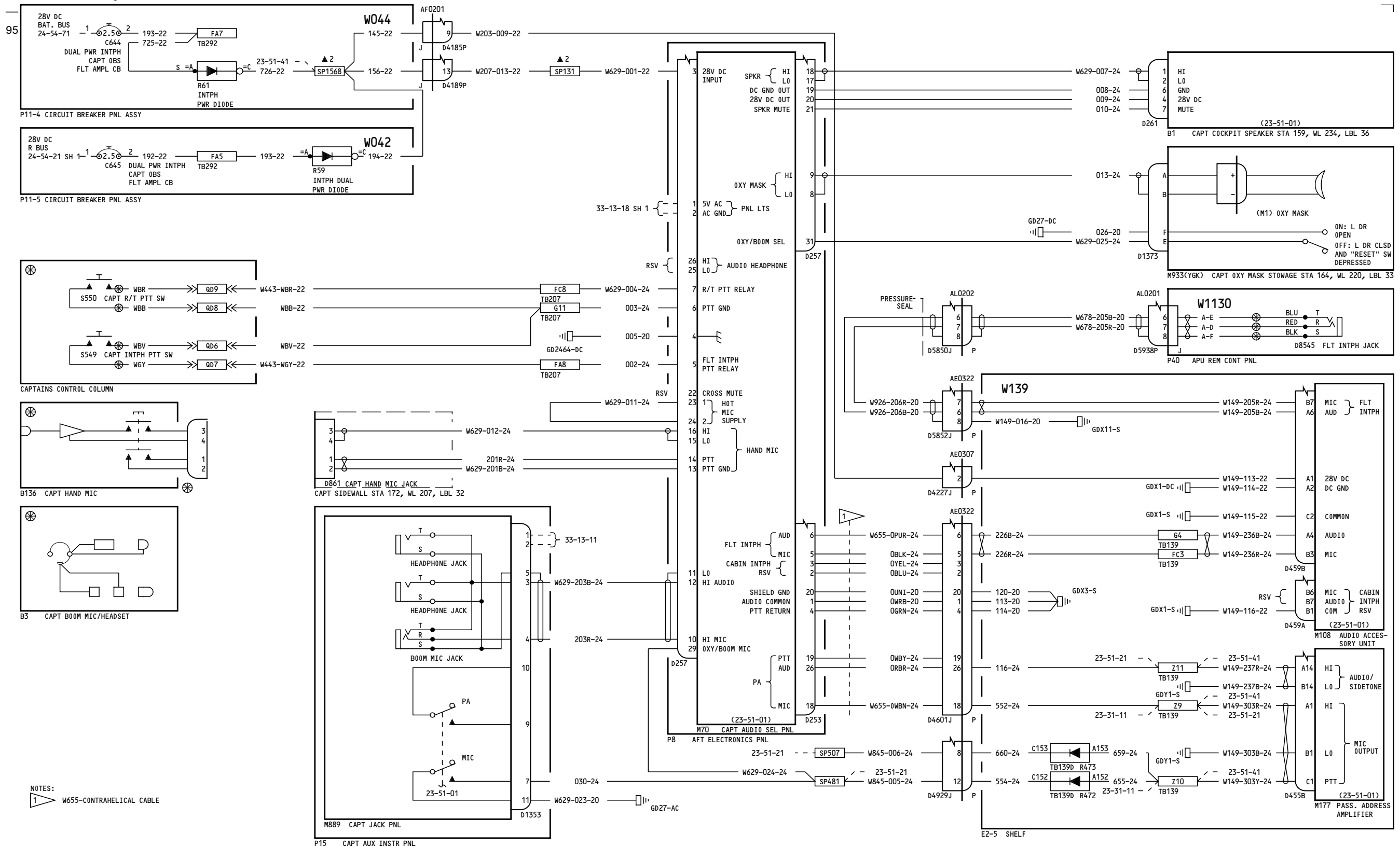

NOTES:
1 W655-CONTRAHELICAL CABLE

151-152

**FLIGHT INTERPHONE-
CAPTAIN-
PART A**

D280T132

23-51-11
Page 3.1
Jan 21/2005

Incorporates
23-0032 R01

23-51-11
Page 3.1
Jan 21/2005

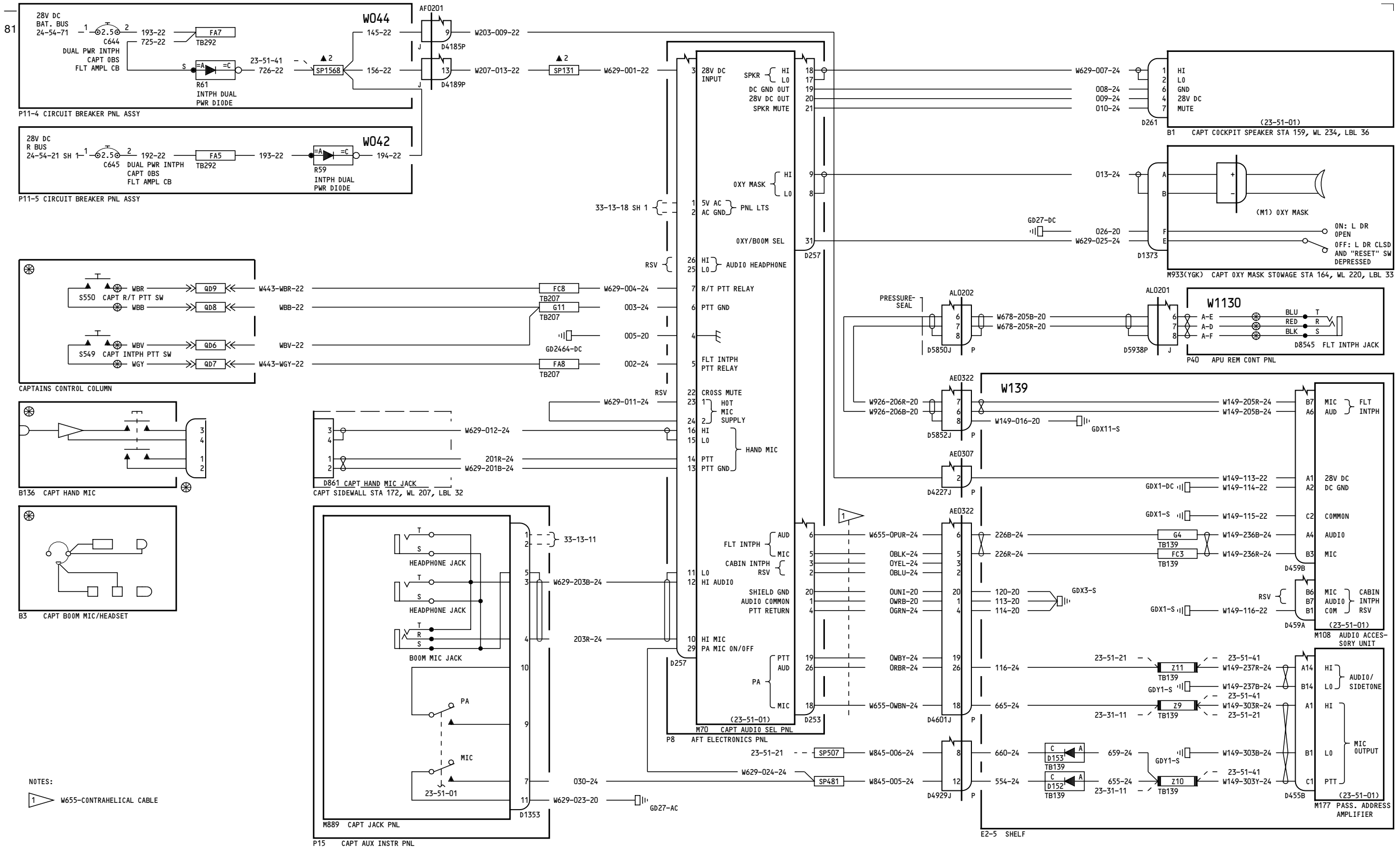

NOTES:
 W655-CONTRAHELICAL CABLE

153-154

FLIGHT INTERPHONE-CAPTAIN-PART A

23-51-11

Page 4

D280T132

Jan 21/2005

23-51-11

Page 4

Jan 21/2005

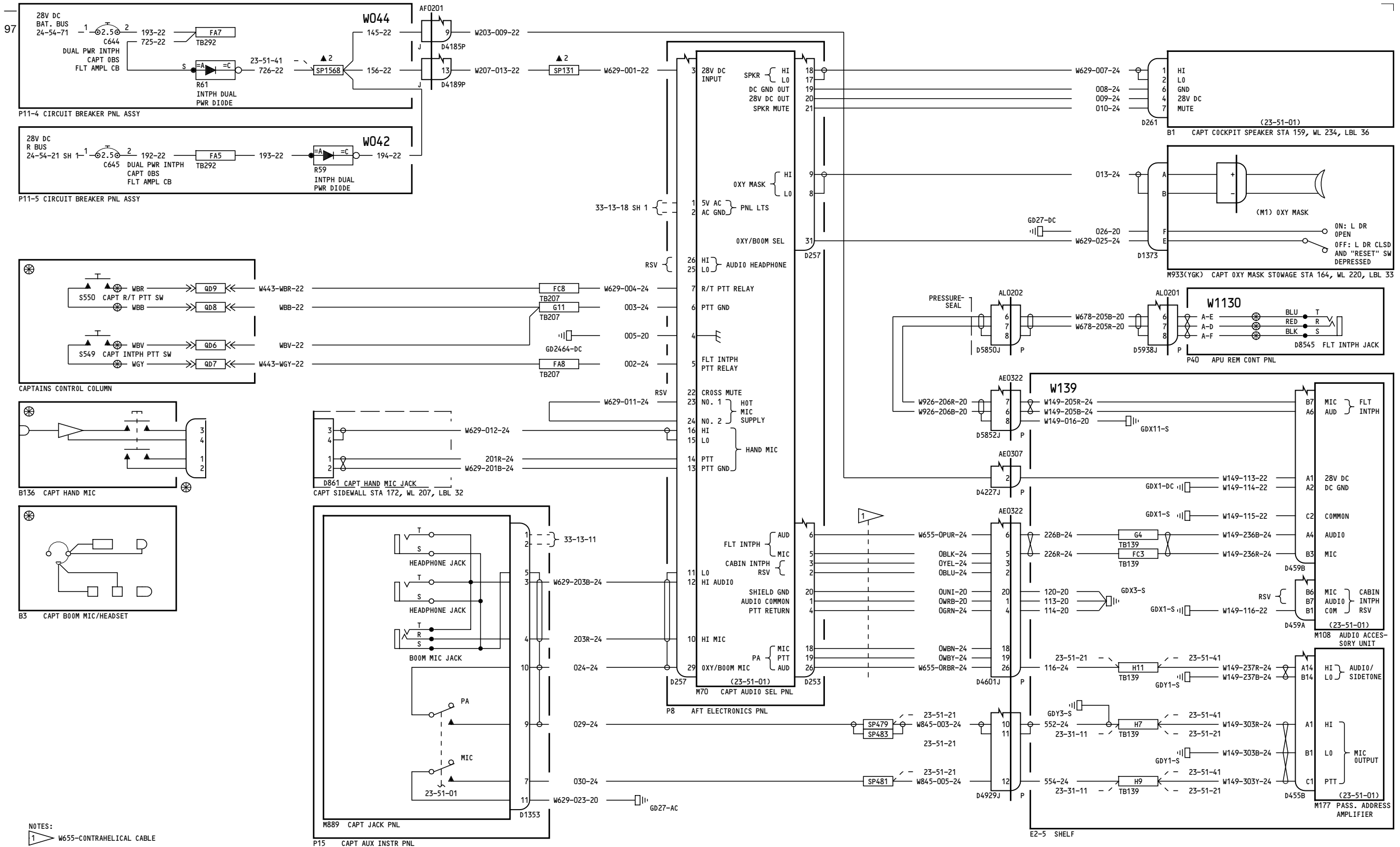

NOTES:
 1 W655-CONTRAHELICAL CABLE

275-276

**FLIGHT INTERPHONE-
 CAPTAIN-
 PART A**

D280T132

23-51-11

Page 5.1

Jan 21/2005

Incorporates
 32-0085

23-51-11

Page 5.1

Jan 21/2005

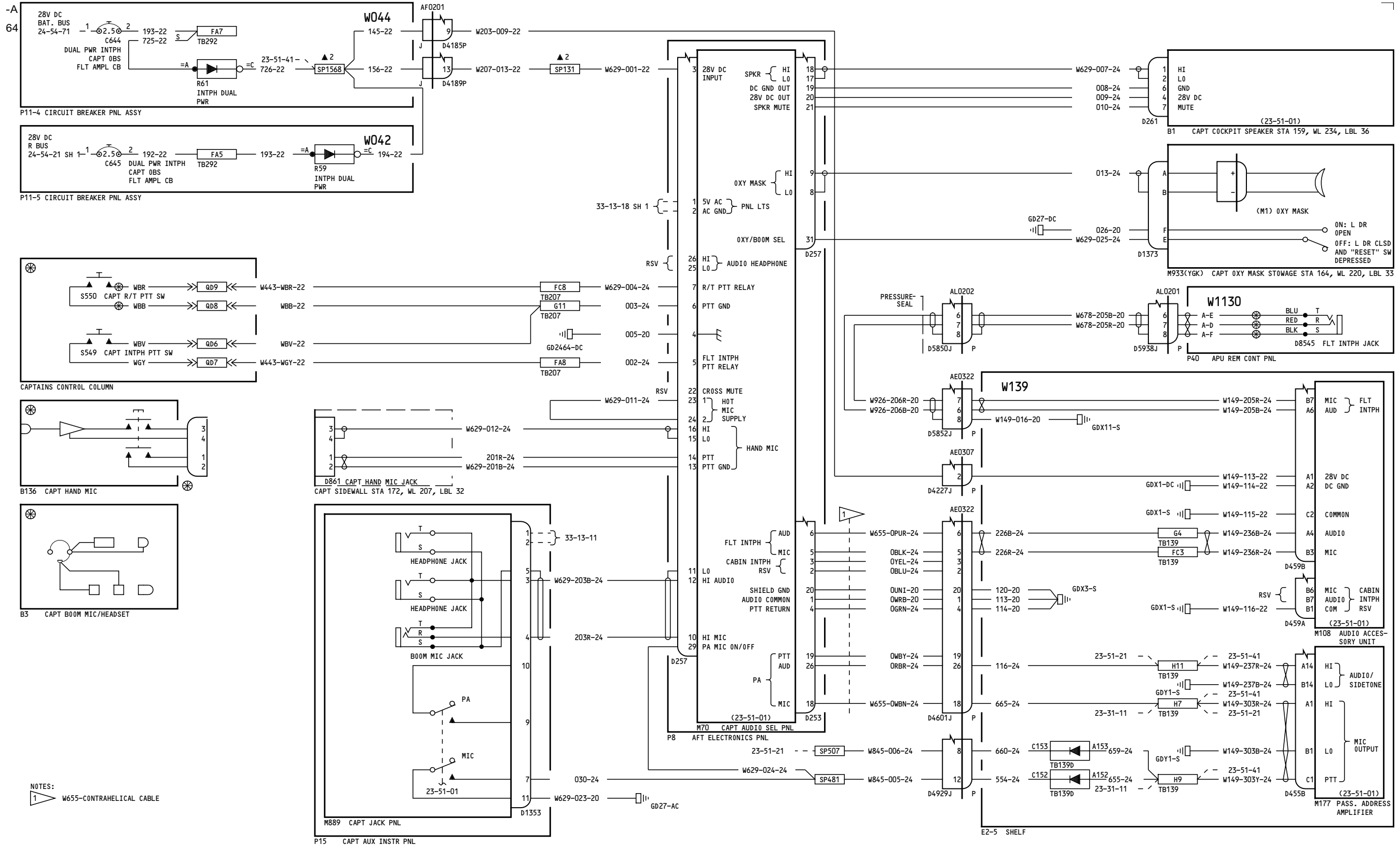

NOTES:
 1 W655-CONTRAHELICAL CABLE

277-299

FLIGHT INTERPHONE-CAPTAIN-PART A

23-51-11

23-51-11

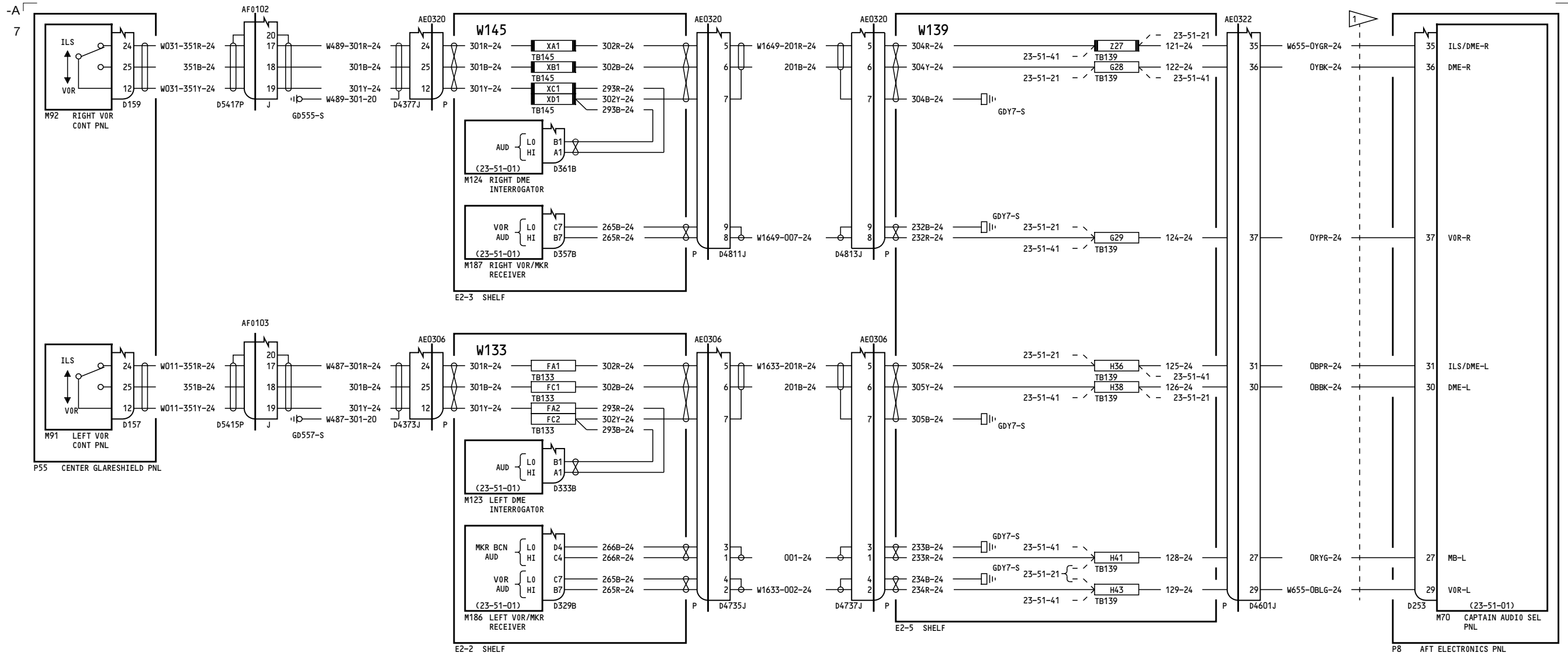

NOTES:
 1 W655- CONTRAHELICAL CABLE

050-099, 150-199

**FLIGHT INTERPHONE-
CAPTAIN-
PART B**

23-51-12

Page 1

D280T132

Jan 21/2005

23-51-12

Page 1

Jan 21/2005

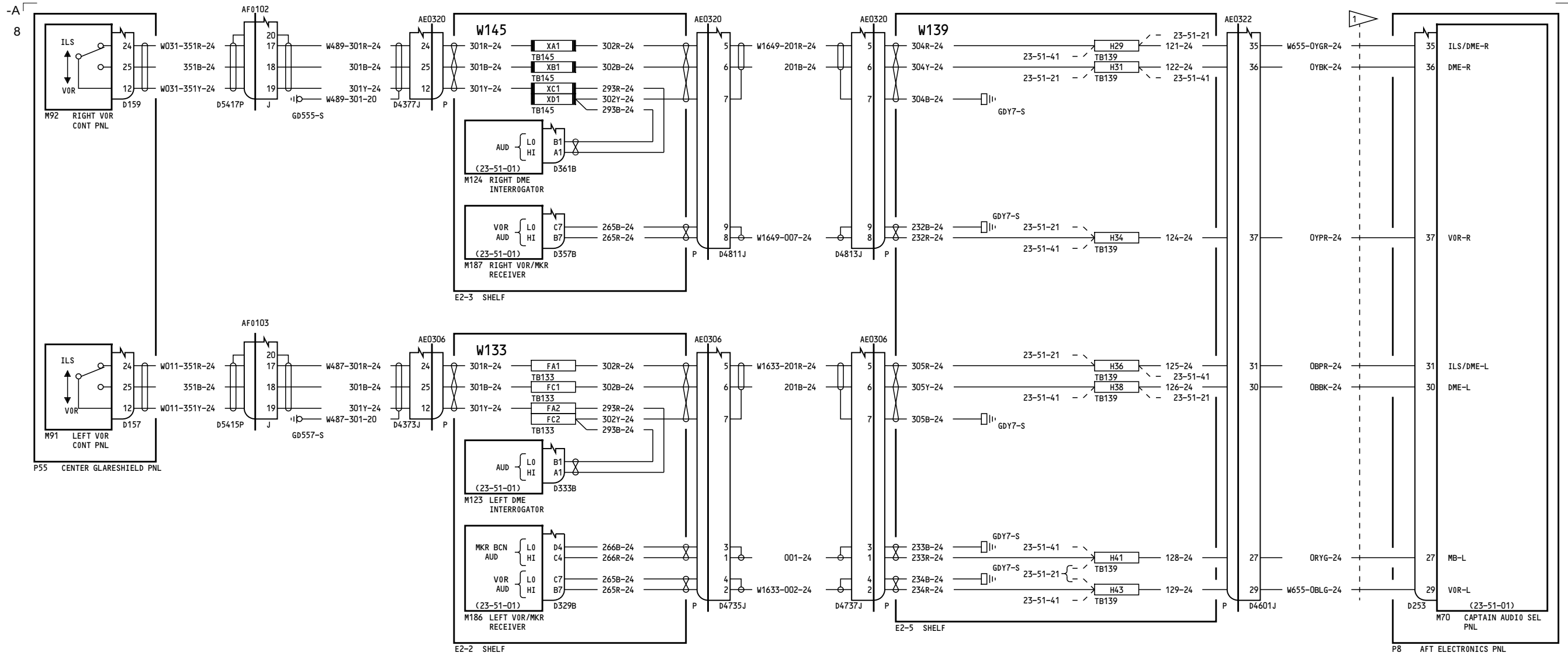

NOTES:
 1 W655- CONTRAHELICAL CABLE

275-276

**FLIGHT INTERPHONE-
 CAPTAIN-
 PART B**

D280T132

23-51-12

Page 2

Jan 21/2005

23-51-12

Page 2

Jan 21/2005

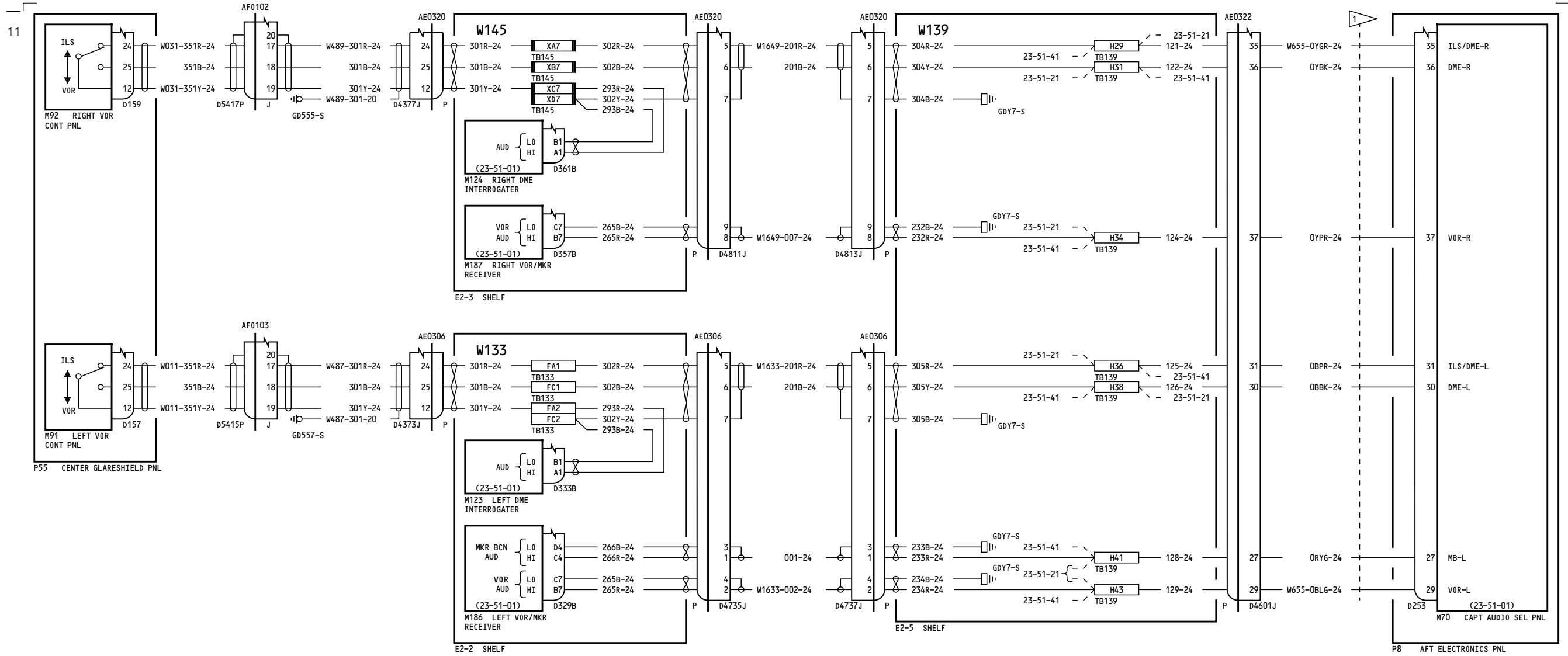

NOTES:
1 W655- CONTRAHELICAL CABLE

277-299

FLIGHT INTERPHONE-
CAPTAIN-
PART B

23-51-12

Page 3

D280T132

Jan 21/2005

23-51-12

Page 3

Jan 21/2005

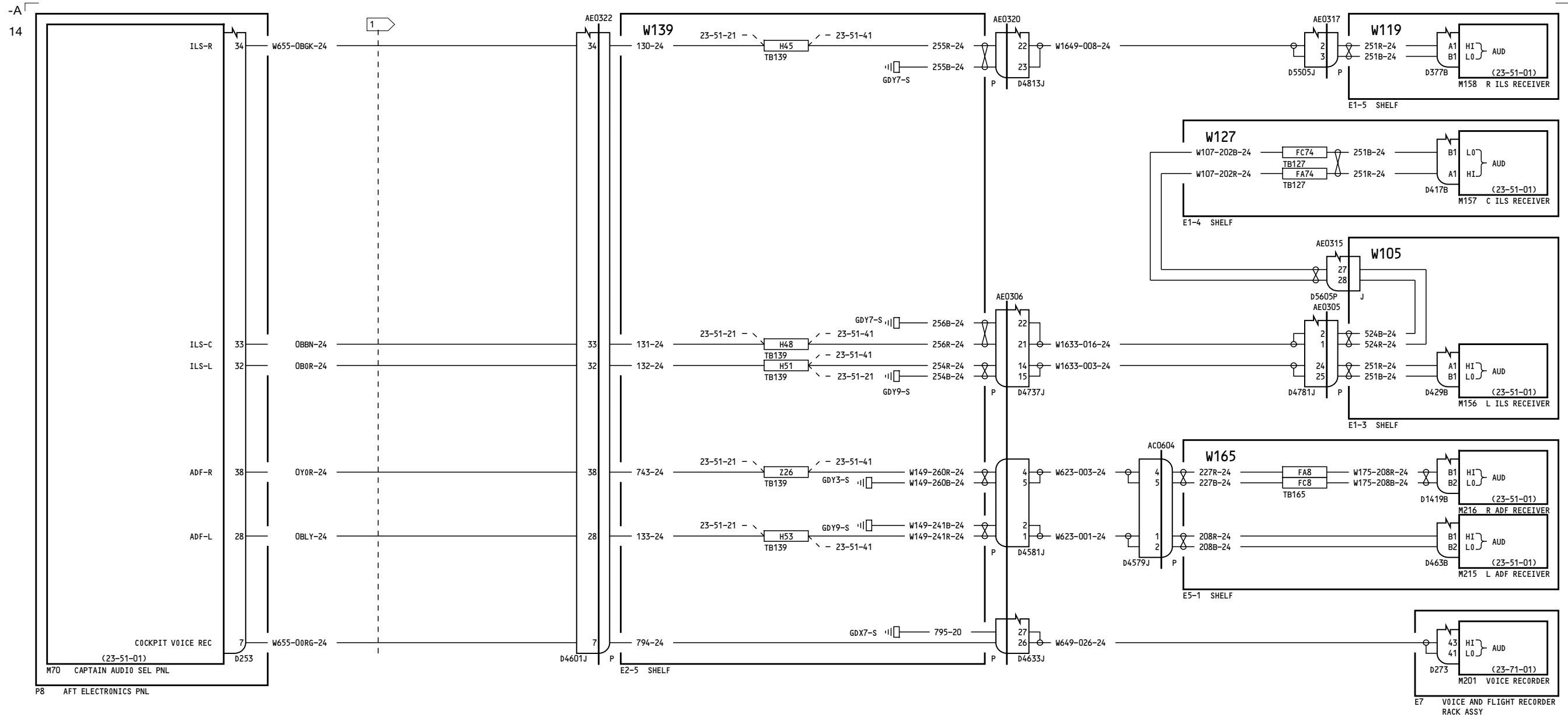

NOTES:
 1 W655-CONTRAHELICAL CABLE

050-099, 150-199

FLIGHT INTERPHONE-CAPTAIN-PART C

D280T132

23-51-13

Page 1

Jan 21/2005

23-51-13

Page 1

Jan 21/2005

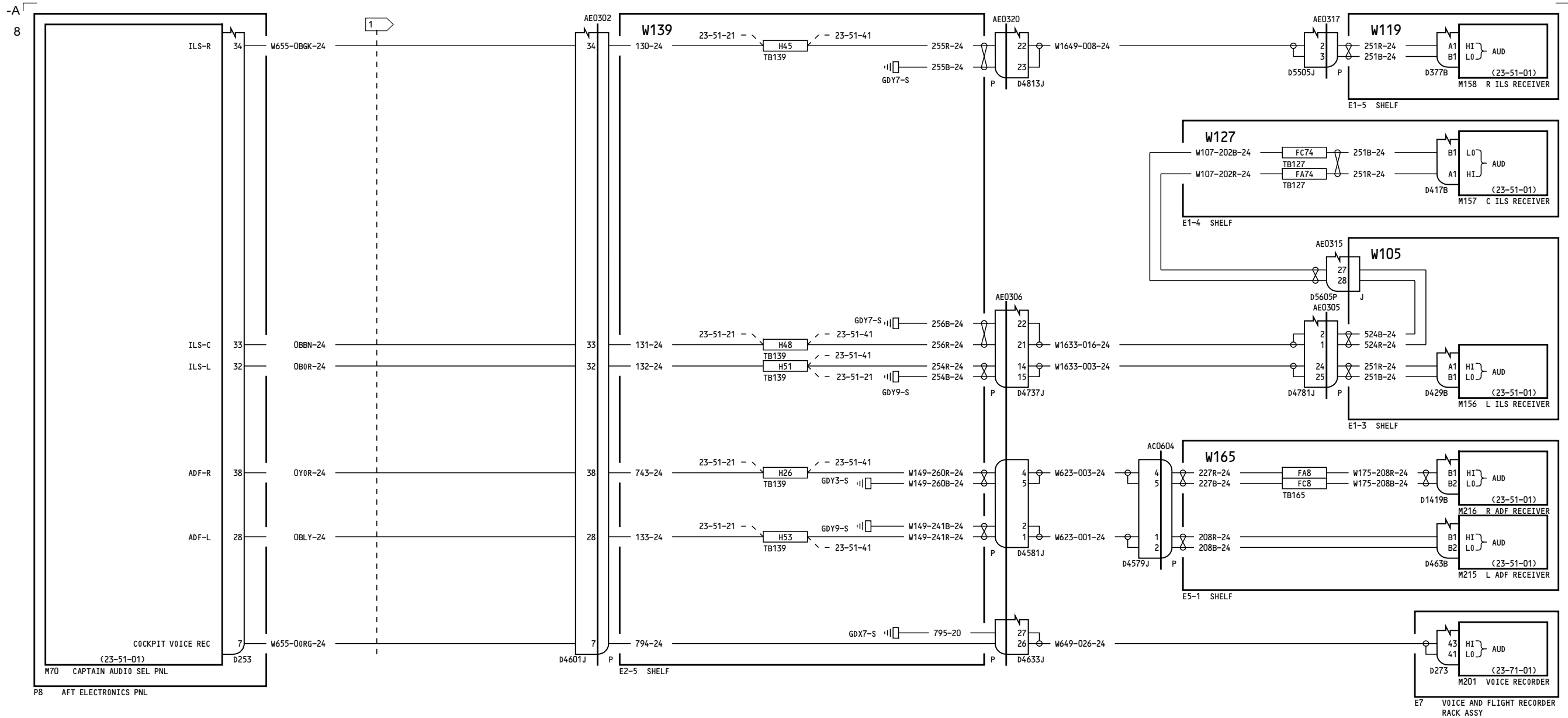

NOTES:
 1 W655-CONTRAHELICAL CABLE

275-299

**FLIGHT INTERPHONE-
 CAPTAIN-
 PART C**

D280T132

23-51-13

Page 2

Jan 21/2005

23-51-13

Page 2

Jan 21/2005

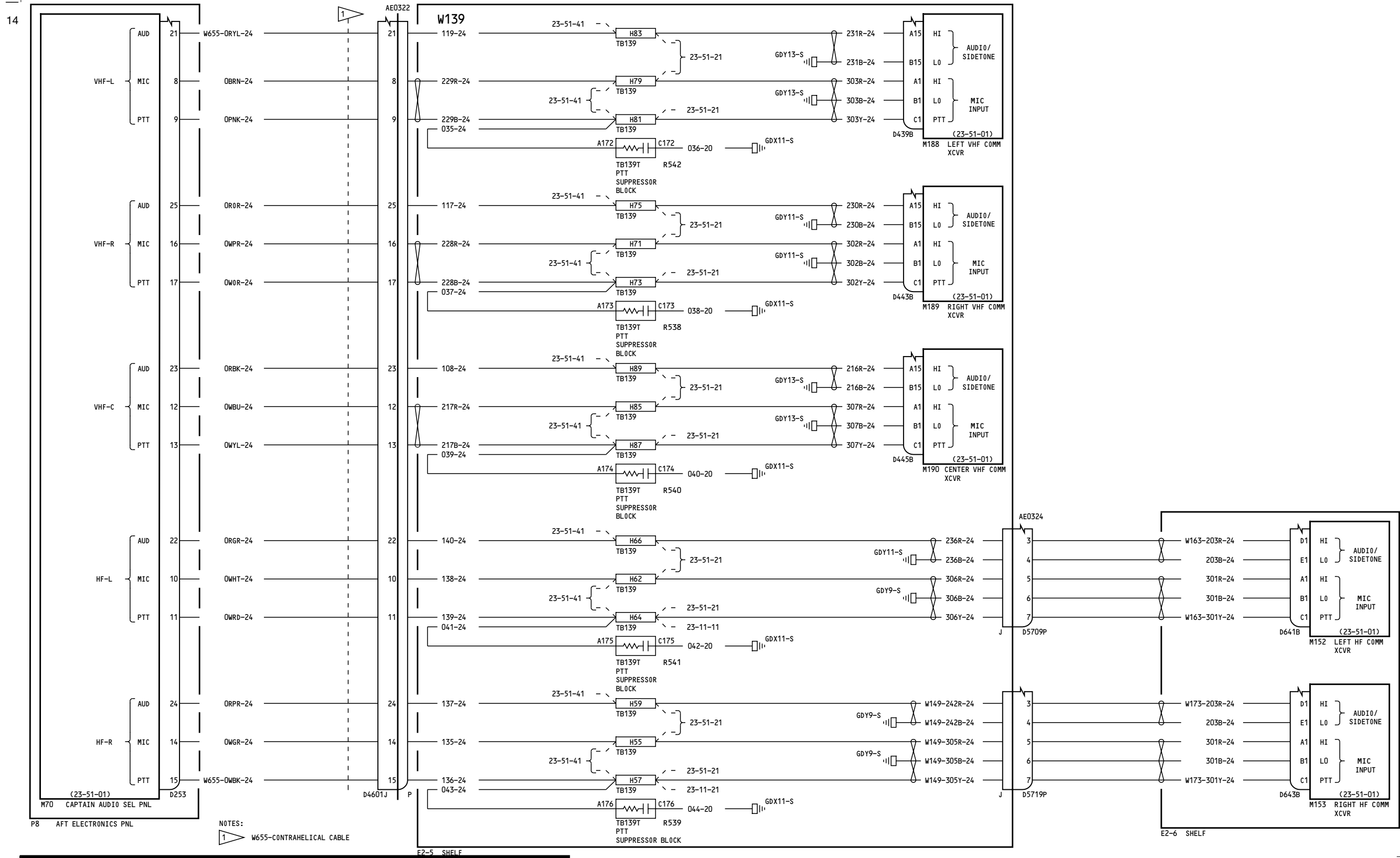

050-099, 151-152, 275-276

**FLIGHT INTERPHONE-
CAPTAIN-
PART D**

23-51-14

Page 1

D280T132

Jan 21/2005

23-51-14

Page 1

Jan 21/2005

23-51-14

Page 1

Jan 21/2005

28

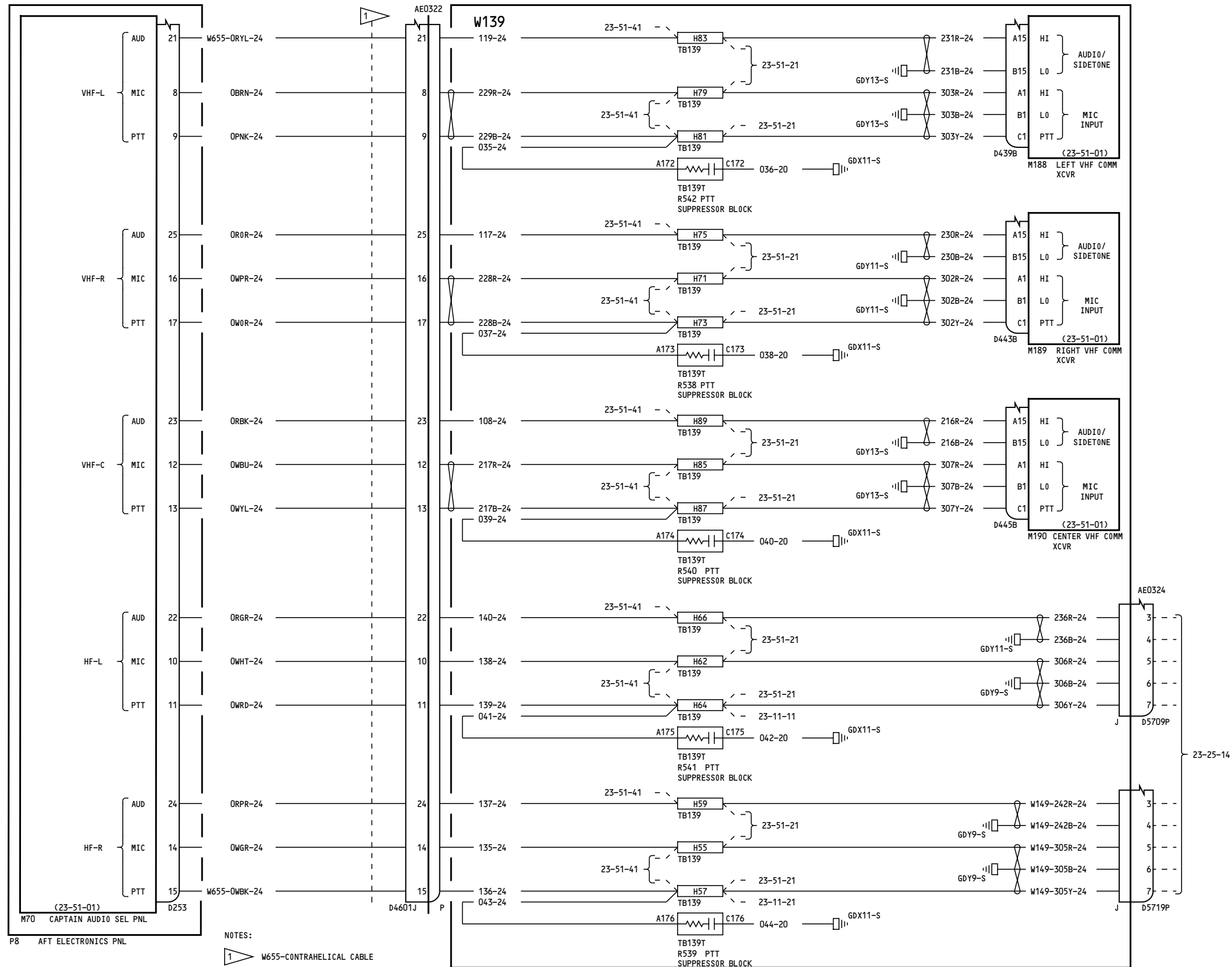

150, 153-155

**FLIGHT INTERPHONE-
CAPTAIN-
PART D**

23-51-14

Incorporates
MTO 230593

23-51-14

Page 2A

Page 2A

D280T132

Jan 21/2005

Jan 21/2005

28

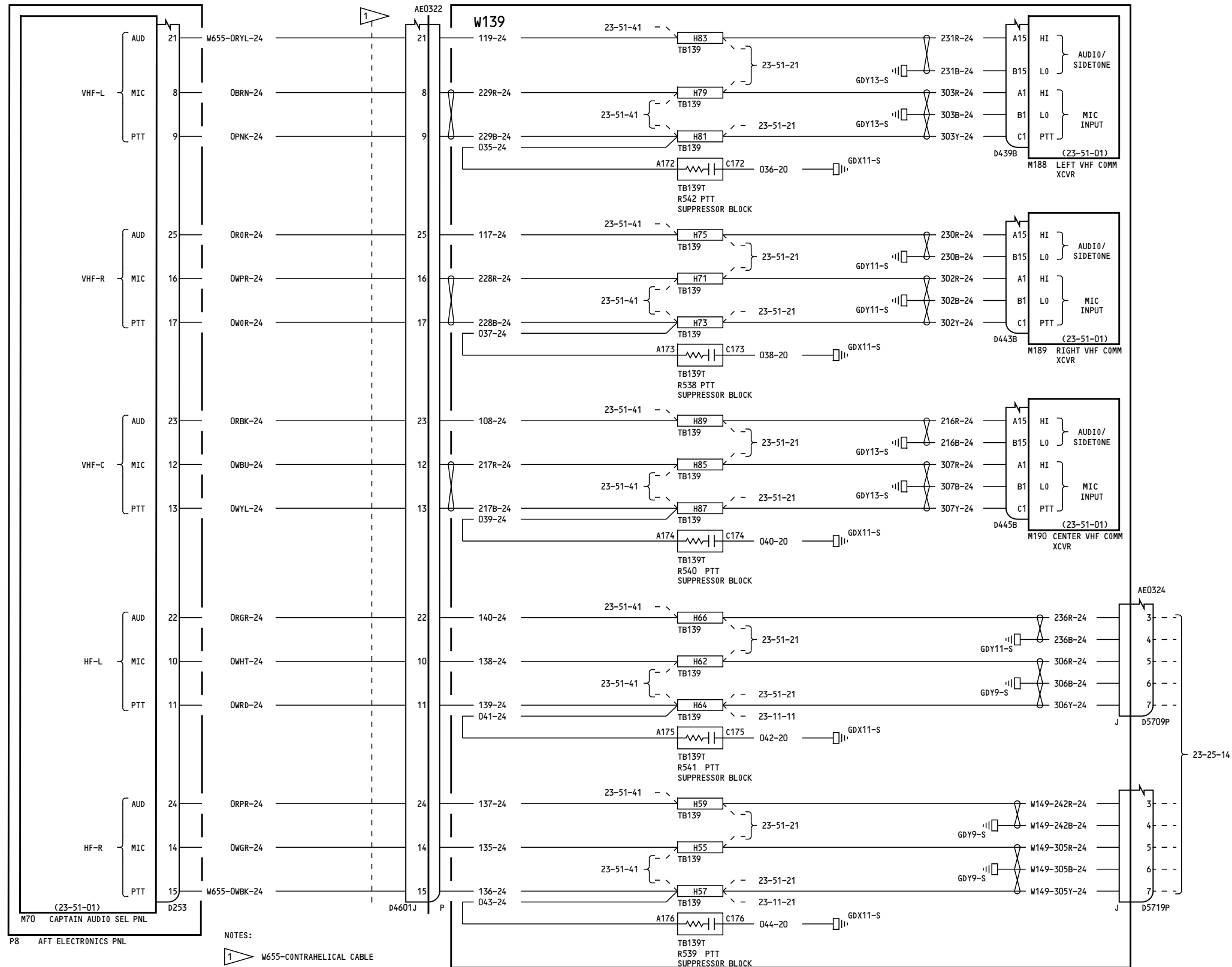

156-157, 166-199, 277-299

FLIGHT INTERPHONE-CAPTAIN-PART D

23-51-14

Page 3

D280T132

Jan 21/2005

23-51-14

Page 3

Jan 21/2005

28

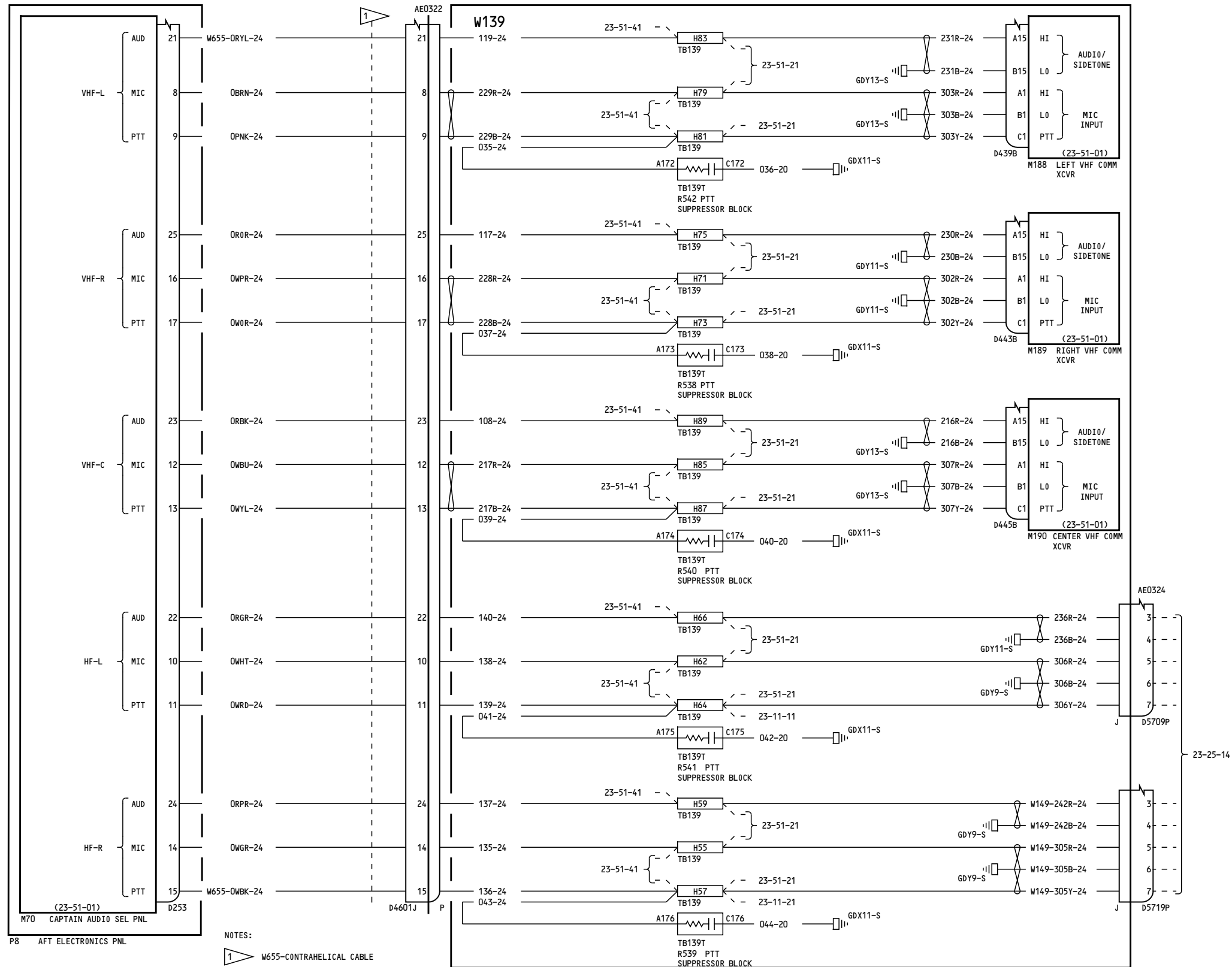

NOTES:
 1 W655-CONTRAHELICAL CABLE

162-165

**FLIGHT INTERPHONE-
 CAPTAIN-
 PART D**

23-51-14

Incorporates
 MTO 230592

23-51-14

Page 4A

Page 4A

D280T132

Jan 21/2005

Jan 21/2005

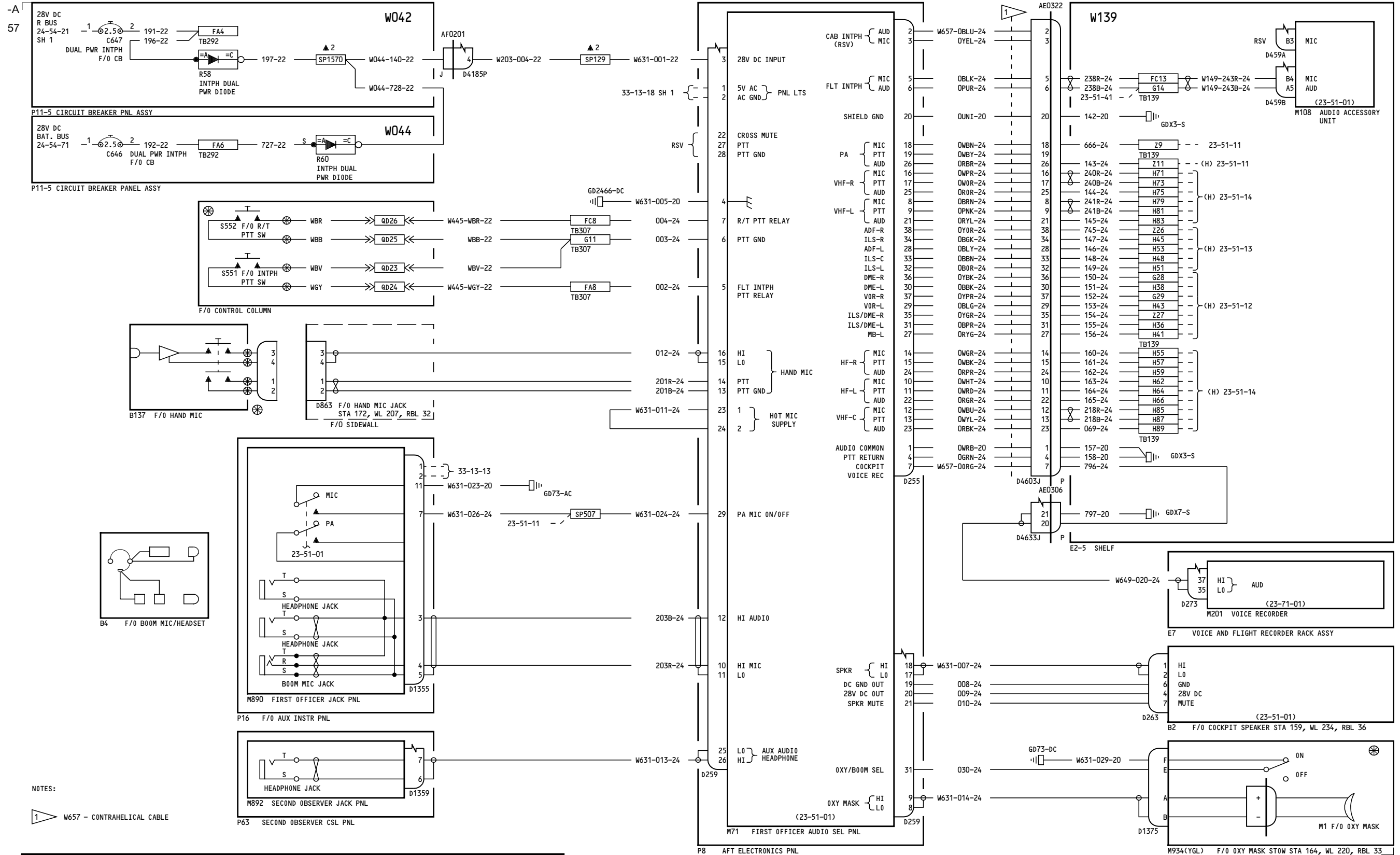

NOTES:
 1 W657 - CONTRAHELICAL CABLE

050-099, 153-199

**FLIGHT INTERPHONE-
FIRST OFFICER**

D280T132

23-51-21

Page 1

Jan 21/2005

23-51-21

Page 1

Jan 21/2005

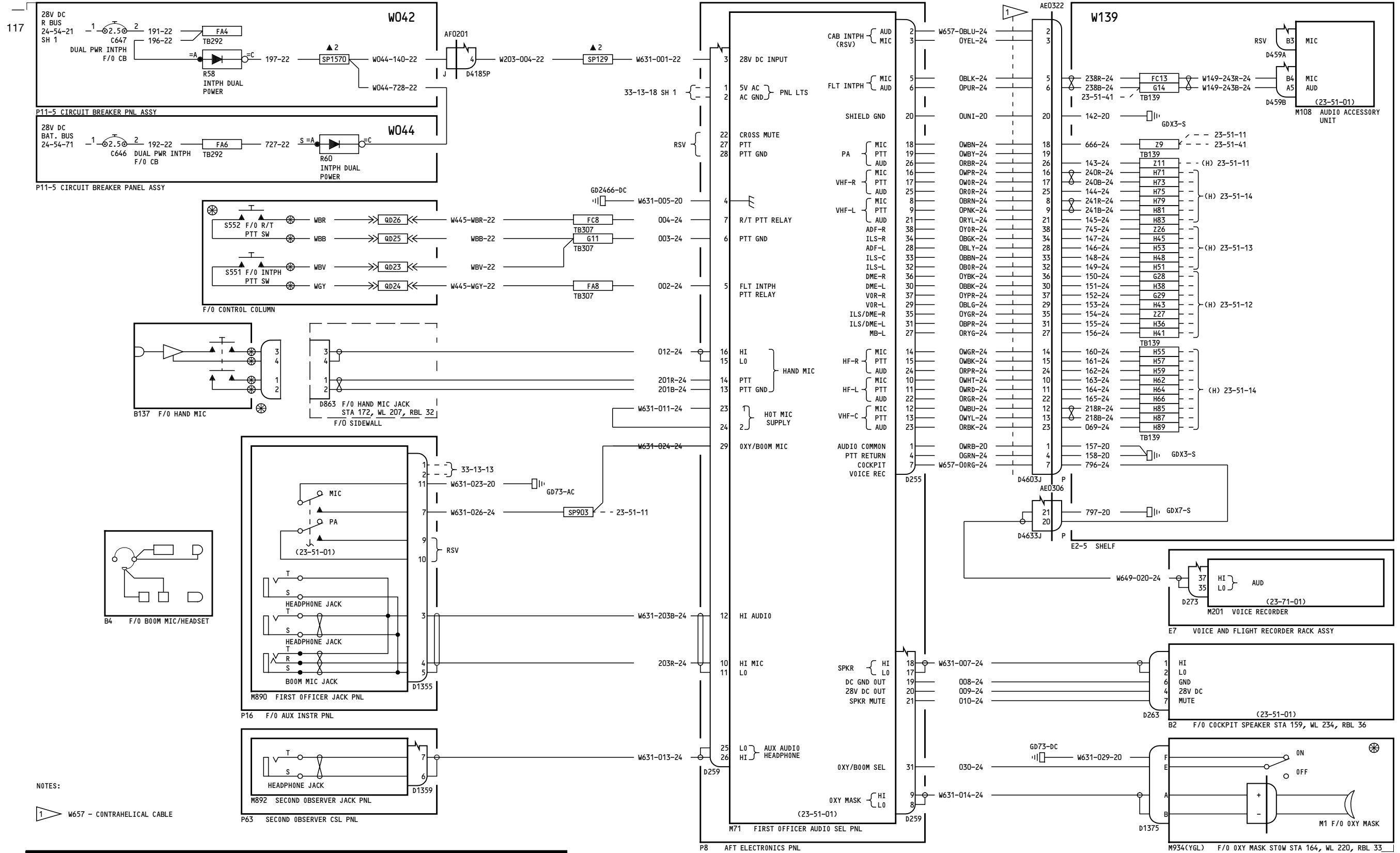

NOTES:
 1 W657 - CONTRAHELICAL CABLE

150

**FLIGHT INTERPHONE-
FIRST OFFICER**

D280T132

23-51-21

Page 2.1A

Jan 21/2005

Incorporates
 23-0032 R01
 ATA 23/9/90

23-51-21

Page 2.1A

Jan 21/2005

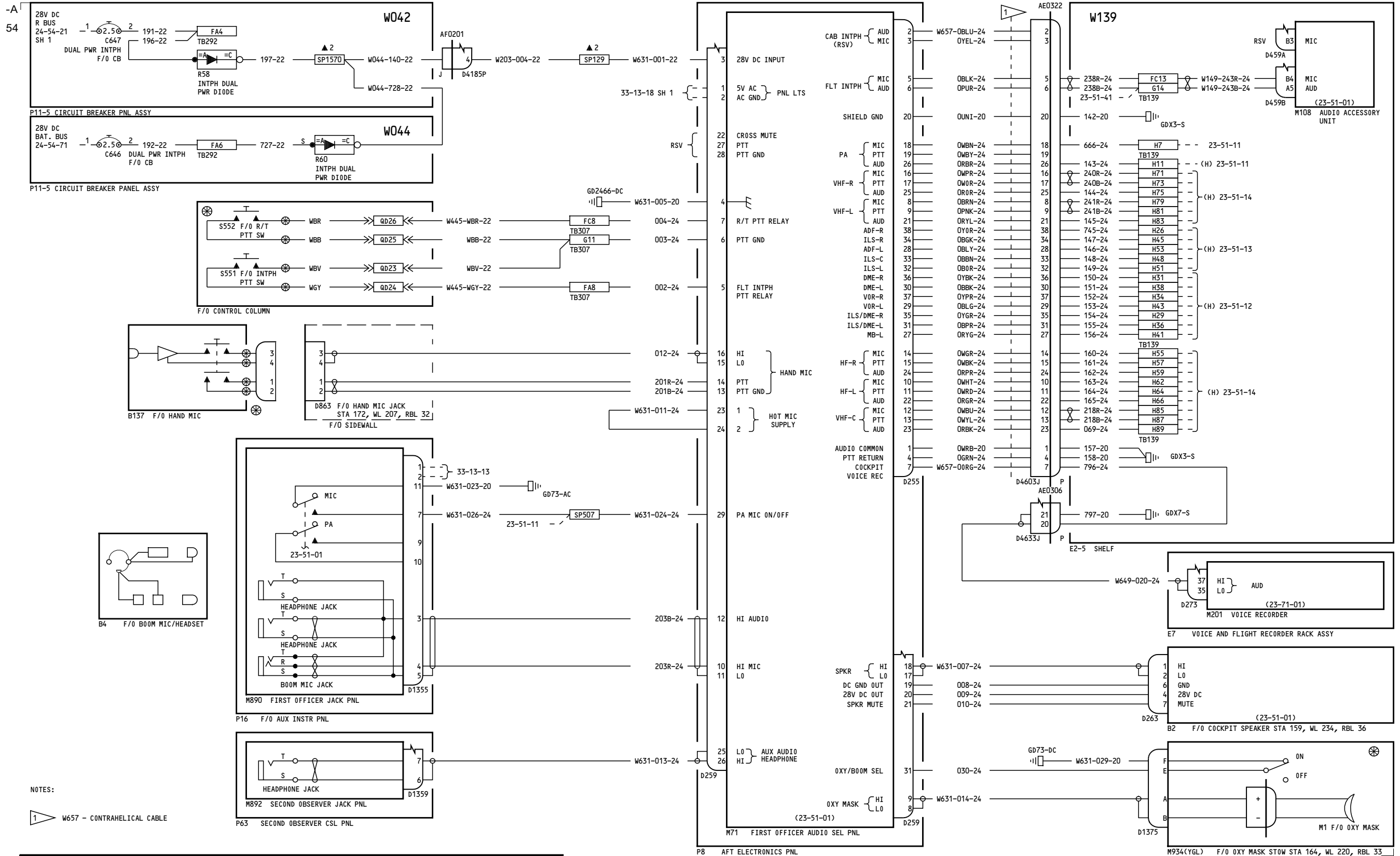

NOTES:
 1 W657 - CONTRAHELICAL CABLE

275-299

FLIGHT INTERPHONE- FIRST OFFICER

D280T132

23-51-21

Page 4
 Jan 21/2005

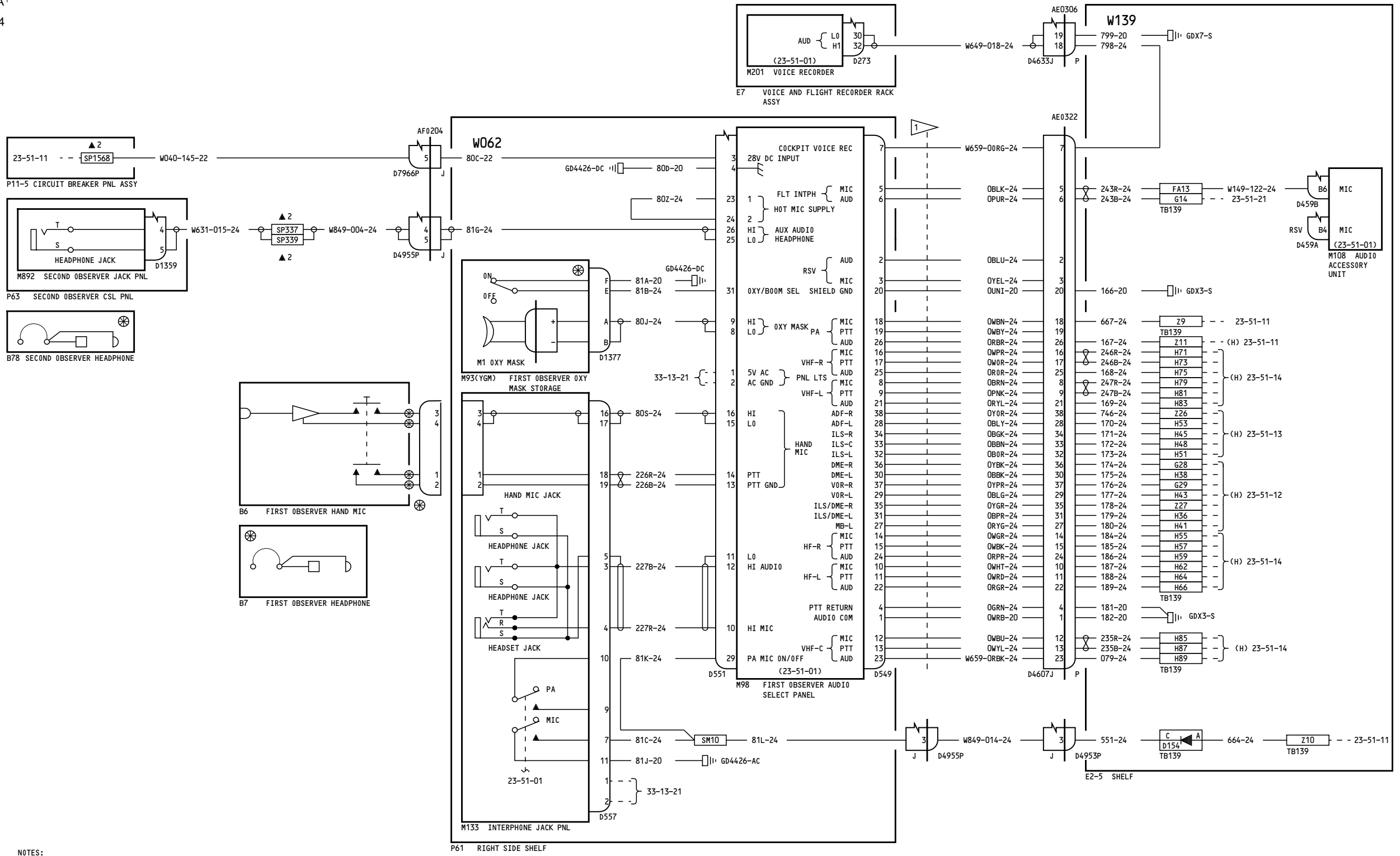

NOTES:
 W659-CONTRAHELICAL CABLE

050-099, 153-199	FLIGHT INTERPHONE- FIRST OBSERVER
	D280T132

23-51-41
 Page 1
 Jan 21/2005

23-51-41
 Page 1
 Jan 21/2005

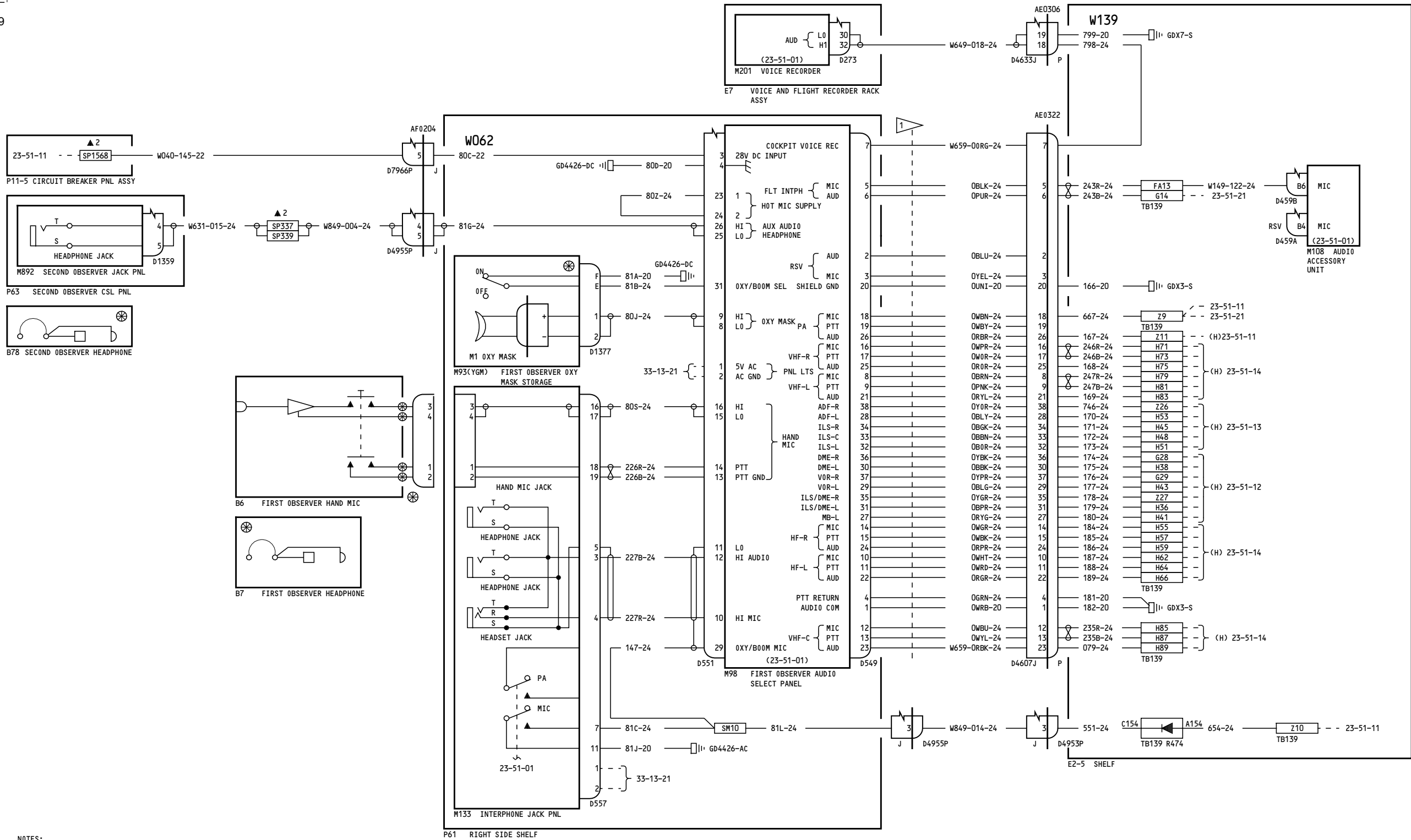

NOTES:
 1 W659-CONTRAHELICAL CABLE

150-152	FLIGHT INTERPHONE- FIRST OBSERVER
	D280T132

23-51-41

Page 2.1

Jan 21/2005

Incorporates
 23-0032 R01

23-51-41

Page 2.1

Jan 21/2005

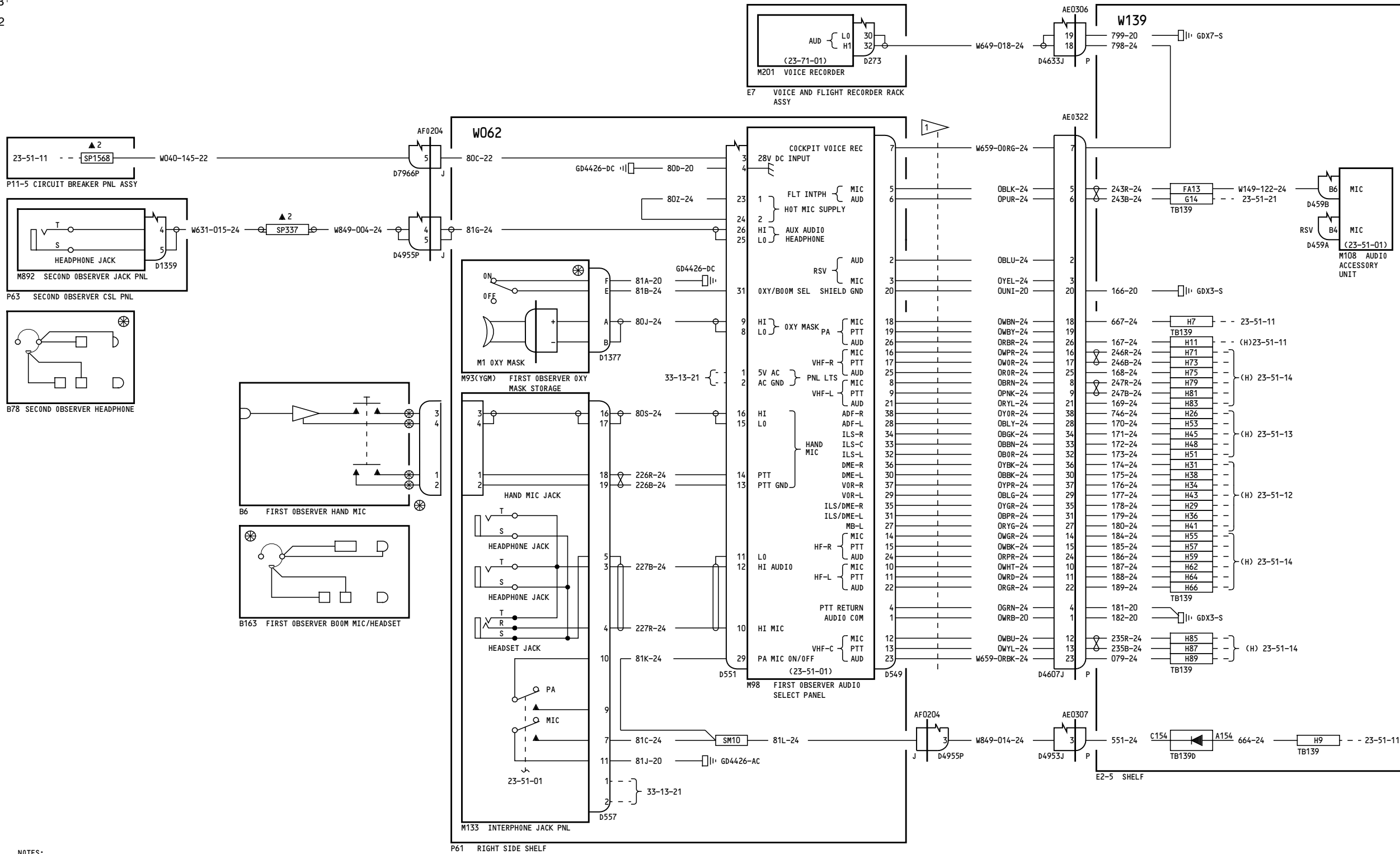

NOTES:
 W659-CONTRAHELICAL CABLE

275-299	FLIGHT INTERPHONE- FIRST OBSERVER D280T132
---------	--------------------------------------------------------------

23-51-41

Page 3

Jan 21/2005

23-51-41

Page 3

Jan 21/2005

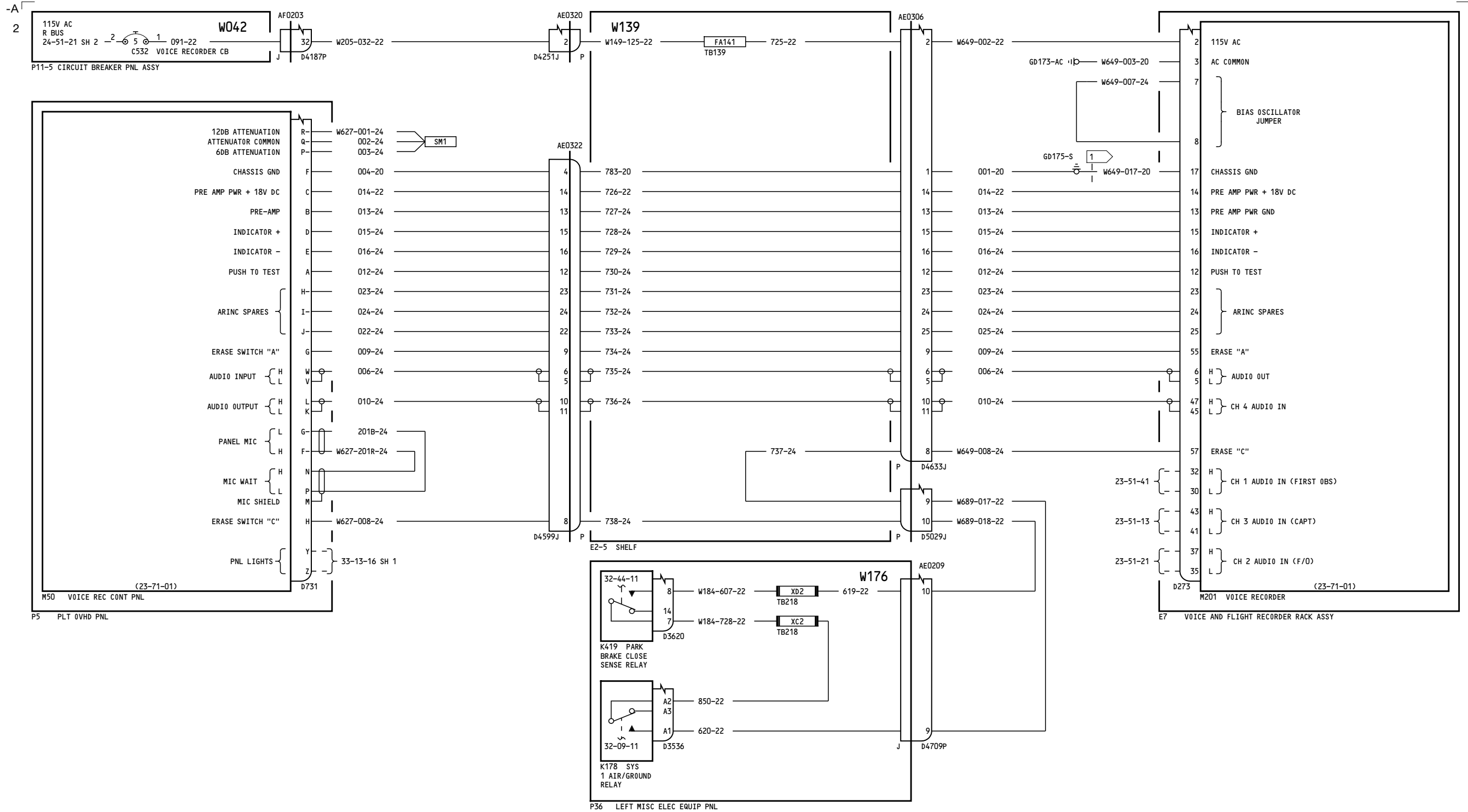

NOTES:
 1 MAX. LENGTH 30 INCHES

ALL	VOICE RECORDER
	D280T132

23-71-11

Page 1

Jan 21/2005

23-71-11

Page 1

Jan 21/2005