

CHAPTER

25

**EQUIPMENT /
FURNISHINGS**



767-200/300

WIRING DIAGRAM MANUAL

CHAPTER 25
EQUIPMENT / FURNISHINGS

CH-SC-SU	Schem	Page	Sheet	Date	CH-SC-SU	Schem	Page	Sheet	Date
25-EFFECTIVE PAGES					25-31-12 (cont.)				
		1 thru 2		Aug 05/2009			4		Jan 21/2005
25-CONTENTS					25-31-21				
		1		Jun 28/2006		1			Jan 21/2005
		2		Jun 28/2006		2	1		Jan 21/2005
		3		Jun 28/2006				2	Jan 21/2005
		4		Jun 28/2006		3	1		Jan 21/2005
		5		Jun 28/2006				2	Jan 21/2005
		6		Jun 28/2006		4	1		Jan 21/2005
25-ALPHABETICAL INDEX					25-31-31				
		1		Jan 21/2005					Jan 21/2005
		2		Jan 21/2005		1			Jan 21/2005
25-11-11						2			Jan 21/2005
		1		Jan 21/2005		3			Jan 21/2005
		2		Jan 21/2005		4			Jan 21/2005
25-11-21					25-33-11				
		1		Jan 21/2005		1.1			Jan 21/2005
		2		Jan 21/2005		2			Jan 21/2005
25-25-23						3			Jan 21/2005
	1A	1		Jan 21/2005		4.1			Jan 21/2005
		2		Jan 21/2005		5.1			Jan 21/2005
		3		Jan 21/2005		6			Jan 21/2005
		4		Jan 21/2005		7			Jan 21/2005
		5		Jan 21/2005		8.1			Jan 21/2005
		6		Jan 21/2005		9			Jan 21/2005
	2A			Jan 21/2005		10			Jan 21/2005
	3A	1		Jan 21/2005	25-42-11				
		2		Jan 21/2005		1			Jan 21/2005
		3		Jan 21/2005		2			Jan 21/2005
		4		Jan 21/2005		3			Jan 21/2005
		5		Jan 21/2005		4			Jan 21/2005
		6		Jan 21/2005		5			Jan 21/2005
25-25-24					25-53-11				
	1A			Jan 21/2005		1			Jan 21/2005
25-29-11						2			Jan 21/2005
	1			Jan 21/2005	25-53-12				
	2			Jan 21/2005		1	1		Jan 21/2005
25-29-12							2		Jan 21/2005
	1			Jan 21/2005			3		Jan 21/2005
	2			Jan 21/2005		2	1		Jan 21/2005
	3			Jan 21/2005			2		Jan 21/2005
25-31-11							3		Jan 21/2005
	1			Jan 21/2005			4		Jan 21/2005
	2			Jan 21/2005		3	1		Jan 21/2005
	3			Jan 21/2005			2		Jan 21/2005
	4			Jan 21/2005			3		Jan 21/2005
	5			Jan 21/2005			4		Jan 21/2005
	6			Jan 21/2005	25-53-13				
25-31-12						1	1		Jan 21/2005
	1			Jan 21/2005			2		Jan 21/2005
	2			Jan 21/2005		2	1		Jan 21/2005
	3			Jan 21/2005			2		Jan 21/2005

A = Added, R = Revised, D = Deleted, O = Overflow

25-EFFECTIVE PAGES

Page 1
Aug 05/2009

D280T132



767-200/300

WIRING DIAGRAM MANUAL

CHAPTER 25
EQUIPMENT / FURNISHINGS

CH-SC-SU	Schem	Page	Sheet	Date	CH-SC-SU	Schem	Page	Sheet	Date
25-53-13 (cont.)		2			25-53-23 (cont.)				
			3	Jan 21/2005			2	1	Jan 21/2005
25-53-14								2	Jan 21/2005
	1		1	Jan 21/2005			3	1	Jan 21/2005
			2	Jan 21/2005				2	Jan 21/2005
			3	Jan 21/2005	25-53-24				
			4	Jan 21/2005		1		1	Jan 21/2005
	2		1	Jan 21/2005				2	Jan 21/2005
			2	Jan 21/2005				3	Jan 21/2005
			3	Jan 21/2005				4	Jan 21/2005
			4	Jan 21/2005		2		1	Jan 21/2005
			5	Jan 21/2005				2	Jan 21/2005
	3		1	Jan 21/2005				3	Jan 21/2005
			2	Jan 21/2005				4	Jan 21/2005
			3	Jan 21/2005				5	Jan 21/2005
			4	Jan 21/2005	25-53-25				
			5	Jan 21/2005		1			Jan 21/2005
25-53-15						2			Jan 21/2005
	1			Jan 21/2005		3			Jan 21/2005
	2			Jan 21/2005	25-53-26				
	3			Jan 21/2005		1	1		Jan 21/2005
25-53-16			1	Jan 21/2005				2	Jan 21/2005
			2	Jan 21/2005		2	1		Jan 21/2005
	1		1	Jan 21/2005				2	Jan 21/2005
			2	Jan 21/2005		3	1		Jan 21/2005
			2	Jan 21/2005				2	Jan 21/2005
	3		1	Jan 21/2005	25-53-27				
			2	Jan 21/2005		1			Jan 21/2005
25-53-17						2			Jan 21/2005
	1			Jan 21/2005	25-63-11				
	2			Jan 21/2005		1	1		Jan 21/2005
	3A			Jan 21/2005				2	Jan 21/2005
	4A			Jan 21/2005		2	1		Jan 21/2005
25-53-21								2	Jan 21/2005
	1			Jan 21/2005				2	Jan 21/2005
	2			Jan 21/2005		3	1		Jan 21/2005
	3			Jan 21/2005				2	Jan 21/2005
25-53-22					25-65-11				
	1		1	Jan 21/2005		1			Jan 21/2005
			2	Jan 21/2005		2	1		Jan 21/2005
			3	Jan 21/2005				2	Jan 21/2005
			3	Jan 21/2005		3	1		Jan 21/2005
	2		1	Jan 21/2005				2	Jan 21/2005
			2	Jan 21/2005					
			2	Jan 21/2005					
			3	Jan 21/2005		1			Jan 21/2005
			4	Jan 21/2005		2	1		Jan 21/2005
	3		1	Jan 21/2005				2	Jan 21/2005
			2	Jan 21/2005		3	1		Jan 21/2005
			3	Jan 21/2005				2	Jan 21/2005
			4	Jan 21/2005	25-65-12				
25-53-23						1			Jan 21/2005
						2			Jan 21/2005
	1		1	Jan 21/2005					
			2	Jan 21/2005					

A = Added, R = Revised, D = Deleted, O = Overflow

25-EFFECTIVE PAGES

Page 2
Aug 05/2009

D280T132



767-200/300

WIRING DIAGRAM MANUAL

**CHAPTER 25
EQUIPMENT / FURNISHINGS**

Title	CH-SC-SU	Schem	Page	Sheet	Date	Effectivity	
<u>FLIGHT COMPARTMENT SEATS</u>							
POWER SEAT- CAPTAIN	25-11-11		1		Jan 21/2005	050-099	
			2		Jan 21/2005	150-199 275-299	
POWER SEAT- FIRST OFFICER	25-11-21		1		Jan 21/2005	050-099	
			2		Jan 21/2005	150-199 275-299	
<u>PASSENGER SEATS</u>							
IN SEAT POWER OUTLETS FORWARD CABIN	25-25-23		1A	1	Jan 21/2005	150 153 157	
				2	Jan 21/2005	150 153 157	
				3	Jan 21/2005	150 153 157	
				4	Jan 21/2005	150 153 157	
				5	Jan 21/2005	150 153 157	
				6	Jan 21/2005	150 153 157	
				2A	Jan 21/2005	154-156 162-164	
				3A	1	Jan 21/2005	165-167
					2	Jan 21/2005	165-167
					3	Jan 21/2005	165-167
					4	Jan 21/2005	165-167
					5	Jan 21/2005	165-167
					6	Jan 21/2005	165-167
			IN SEAT POWER OUTLETS MID CABIN	25-25-24		1A	
<u>PASSENGER AND CABIN ATTENDANT ACCOMMODATIONS</u>							
SERVICE OUTLETS	25-29-11		1		Jan 21/2005	050-099	
			2		Jan 21/2005	150-199 275-299	
MEDICAL OUTLETS	25-29-12		1		Jan 21/2005	050-099	
			2		Jan 21/2005	150-199	
			3		Jan 21/2005	275-299	
<u>GALLEYS</u>							
GALLEY POWER- FORWARD	25-31-11		1		Jan 21/2005	050-099	
			2		Jan 21/2005	150-154	
			3		Jan 21/2005	155-199	
			4		Jan 21/2005	275-276	

25-CONTENTS



767-200/300

WIRING DIAGRAM MANUAL

**CHAPTER 25
EQUIPMENT / FURNISHINGS**

Title	CH-SC-SU	Schem	Page	Sheet	Date	Effectivity
GALLEY POWER- FORWARD (cont.)	25-31-11		5		Jan 21/2005	277-278
			6		Jan 21/2005	280-299
GALLEY POWER- LEFT FORWARD	25-31-12		1		Jan 21/2005	050-099
			2		Jan 21/2005	150-152
			3		Jan 21/2005	153-154
			4		Jan 21/2005	155-199
GALLEY POWER- LEFT AFT	25-31-21		1		Jan 21/2005	050-099 150-199
			2	1	Jan 21/2005	275-276
				2	Jan 21/2005	275-276
			3	1	Jan 21/2005	277-278
				2	Jan 21/2005	277-278
			4	1	Jan 21/2005	280-299
	2	Jan 21/2005	280-299			
GALLEY POWER- RIGHT AFT	25-31-31		1		Jan 21/2005	050-099 150-199
			2		Jan 21/2005	275-276
			3		Jan 21/2005	277-278
			4		Jan 21/2005	280-299
<u>REFRIGERATION</u>						
REFRIGERATION POWER	25-33-11		1.1		Jan 21/2005	050-051
			2		Jan 21/2005	150-152
			3		Jan 21/2005	153-154
			4.1		Jan 21/2005	155-157 165-166
			5.1		Jan 21/2005	162-164
			6		Jan 21/2005	167-199
			7		Jan 21/2005	275-276
			8.1		Jan 21/2005	277
			9		Jan 21/2005	278
			10		Jan 21/2005	280-299
<u>LAVATORY EQUIPMENT</u>						
SHAVER OUTLETS- LAVATORY	25-42-11		1		Jan 21/2005	050-099
			2		Jan 21/2005	150-157

25-CONTENTS



767-200/300

WIRING DIAGRAM MANUAL

**CHAPTER 25
EQUIPMENT / FURNISHINGS**

Title	CH-SC-SU	Schem	Page	Sheet	Date	Effectivity
SHAVER OUTLETS- LAVATORY (cont.)	25-42-11		3		Jan 21/2005	162-199
			4		Jan 21/2005	275-278
			5		Jan 21/2005	280-299
CONTAINERIZED CARGO HANDLING SYSTEM						
CARGO HANDLING- FORWARD LOWER LOBE POWER DISTRIBUTION	25-53-11		1		Jan 21/2005	050-099
			2		Jan 21/2005	150-199 275-299
CARGO HANDLING- FORWARD LOWER LOBE PDU POWER	25-53-12		1	1	Jan 21/2005	050-099
				2	Jan 21/2005	050-099
				3	Jan 21/2005	050-099
			2	1	Jan 21/2005	150-199 275-278
				2	Jan 21/2005	150-199 275-278
				3	Jan 21/2005	150-199 275-278
				4	Jan 21/2005	150-199 275-278
			3	1	Jan 21/2005	280-299
				2	Jan 21/2005	280-299
				3	Jan 21/2005	280-299
CARGO HANDLING- FORWARD LOWER LOBE FWD/AFT PDU CONTROL	25-53-13		1	1	Jan 21/2005	050-099
				2	Jan 21/2005	050-099
			2	1	Jan 21/2005	150-199 275-299
				2	Jan 21/2005	150-199 275-299
				3	Jan 21/2005	150-199 275-299
CARGO HANDLING- FORWARD LOWER LOBE PDU LOAD/UNLOAD CONTROL	25-53-14		1	1	Jan 21/2005	050-099
				2	Jan 21/2005	050-099
				3	Jan 21/2005	050-099
				4	Jan 21/2005	050-099
			2	1	Jan 21/2005	150-199 275-278

25-CONTENTS



767-200/300

WIRING DIAGRAM MANUAL

**CHAPTER 25
EQUIPMENT / FURNISHINGS**

Title	CH-SC-SU	Schem	Page	Sheet	Date	Effectivity	
CARGO HANDLING- FORWARD LOWER LOBE PDU LOAD/UNLOAD CONTROL (cont.)	25-53-14			2	Jan 21/2005	150-199 275-278	
				3	Jan 21/2005	150-199 275-278	
				4	Jan 21/2005	150-199 275-278	
				5	Jan 21/2005	150-199 275-278	
				3	1	Jan 21/2005	280-299
				2	Jan 21/2005	280-299	
				3	Jan 21/2005	280-299	
				4	Jan 21/2005	280-299	
				5	Jan 21/2005	280-299	
				CARGO HANDLING- FORWARD LOWER LOBE LATERAL GUIDES	25-53-15		1
2	Jan 21/2005	150-199 275-278					
3	Jan 21/2005	280-299					
CARGO HANDLING- FORWARD LOWER LOBE CENTER GUIDES	25-53-16		1	1	Jan 21/2005	050-099	
				2	Jan 21/2005	050-099	
				2	1	Jan 21/2005	150-199 275-278
				2	Jan 21/2005	150-199 275-278	
				3	1	Jan 21/2005	280-299
				2	Jan 21/2005	280-299	
CARGO HANDLING- FORWARD LOWER LOBE ROLLOUT STOPS	25-53-17		1		Jan 21/2005	050-099	
				2	Jan 21/2005	150-199	
				3A	Jan 21/2005	275-278	
				4A	Jan 21/2005	280	
CARGO HANDLING- AFT LOWER LOBE POWER DISTRIBUTION	25-53-21		1		Jan 21/2005	050-099	
				2	Jan 21/2005	150-199	
				3	Jan 21/2005	275-299	
CARGO HANDLING- AFT LOWER LOBE PDU POWER	25-53-22		1	1	Jan 21/2005	050-099	

25-CONTENTS



767-200/300

WIRING DIAGRAM MANUAL

CHAPTER 25
EQUIPMENT / FURNISHINGS

Title	CH-SC-SU	Schem	Page	Sheet	Date	Effectivity	
CARGO HANDLING- AFT LOWER LOBE PDU POWER (cont.)	25-53-22			2	Jan 21/2005	050-099	
				3	Jan 21/2005	050-099	
				2	1	Jan 21/2005	150-199 275-278
				2	2	Jan 21/2005	150-199 275-278
				3	3	Jan 21/2005	150-199 275-278
				4	4	Jan 21/2005	150-199 275-278
				3	1	Jan 21/2005	280-299
				2	2	Jan 21/2005	280-299
				3	3	Jan 21/2005	280-299
				4	4	Jan 21/2005	280-299
CARGO HANDLING- AFT LOWER LOBE FWD/AFT PDU CONTROL	25-53-23		1	1	Jan 21/2005	050-099	
				2	Jan 21/2005	050-099	
				2	1	Jan 21/2005	150-199
				2	2	Jan 21/2005	150-199
				3	1	Jan 21/2005	275-299
				2	2	Jan 21/2005	275-299
CARGO HANDLING- AFT LOWER LOBE PDU LOAD/ UNLOAD CONTROL	25-53-24		1	1	Jan 21/2005	050-099	
				2	Jan 21/2005	050-099	
				3	Jan 21/2005	050-099	
				4	Jan 21/2005	050-099	
				2	1	Jan 21/2005	150-199 275-299
				2	2	Jan 21/2005	150-199 275-299
				3	3	Jan 21/2005	150-199 275-299
				4	4	Jan 21/2005	150-199 275-299
				5	5	Jan 21/2005	150-199 275-299
				CARGO HANDLING- AFT LOWER LOBE LATERAL GUIDES	25-53-25		1
2	Jan 21/2005	150-199 275-278					
3	Jan 21/2005	280-299					

25-CONTENTS

Page 5
Jun 28/2006

D280T132



767-200/300

WIRING DIAGRAM MANUAL

**CHAPTER 25
EQUIPMENT / FURNISHINGS**

Title	CH-SC-SU	Schem	Page	Sheet	Date	Effectivity
CARGO HANDLING- AFT LOWER LOBE CENTER GUIDES	25-53-26		1	1	Jan 21/2005	050-099
				2	Jan 21/2005	050-099
			2	1	Jan 21/2005	150-199
				2	Jan 21/2005	150-199
			3	1	Jan 21/2005	275-299
				2	Jan 21/2005	275-299
CARGO HANDLING- AFT LOWER LOBE ROLLOUT STOPS	25-53-27		1		Jan 21/2005	050-099
			2		Jan 21/2005	150-199
<u>EMERGENCY SIGNALING EQUIPMENT</u>						
EMERGENCY EVACUATION SIGNAL SYSTEM CONTROL	25-63-11		1	1	Jan 21/2005	050-099
				2	Jan 21/2005	050-099
			2	1	Jan 21/2005	150-199
				2	Jan 21/2005	150-199
			3	1	Jan 21/2005	275-299
				2	Jan 21/2005	275-299
<u>OFF-WING ESCAPE SYSTEM</u>						
LEFT OFF-WING ESCAPE SYSTEM	25-65-11		1		Jan 21/2005	050-099
			2	1	Jan 21/2005	150-199
				2	Jan 21/2005	150-199
			3	1	Jan 21/2005	275-299
				2	Jan 21/2005	275-299
RIGHT OFF-WING ESCAPE SYSTEM	25-65-12		1		Jan 21/2005	050-099
			2	1	Jan 21/2005	150-199
				2	Jan 21/2005	150-199
			3	1	Jan 21/2005	275-299
				2	Jan 21/2005	275-299

25-CONTENTS



767-200/300

WIRING DIAGRAM MANUAL

CHAPTER 25 EQUIPMENT / FURNISHINGS

CH-SC-SU	Title
25-53-26	CARGO HANDLING- AFT LOWER LOBE CENTER GUIDES
25-53-23	CARGO HANDLING- AFT LOWER LOBE FWD/AFT PDU CONTROL
25-53-25	CARGO HANDLING- AFT LOWER LOBE LATERAL GUIDES
25-53-24	CARGO HANDLING- AFT LOWER LOBE PDU LOAD/UNLOAD CONTROL
25-53-22	CARGO HANDLING- AFT LOWER LOBE PDU POWER
25-53-21	CARGO HANDLING- AFT LOWER LOBE POWER DISTRIBUTION
25-53-27	CARGO HANDLING- AFT LOWER LOBE ROLLOUT STOPS
25-53-16	CARGO HANDLING- FORWARD LOWER LOBE CENTER GUIDES
25-53-13	CARGO HANDLING- FORWARD LOWER LOBE FWD/AFT PDU CONTROL
25-53-15	CARGO HANDLING- FORWARD LOWER LOBE LATERAL GUIDES
25-53-14	CARGO HANDLING- FORWARD LOWER LOBE PDU LOAD/UNLOAD CONTROL
25-53-12	CARGO HANDLING- FORWARD LOWER LOBE PDU POWER
25-53-11	CARGO HANDLING- FORWARD LOWER LOBE POWER DISTRIBUTION
25-53-17	CARGO HANDLING- FORWARD LOWER LOBE ROLLOUT STOPS
25-63-11	EMERGENCY EVACUATION SIGNAL SYSTEM CONTROL
25-31-11	GALLEY POWER- FORWARD
25-31-21	GALLEY POWER- LEFT AFT
25-31-12	GALLEY POWER- LEFT FORWARD
25-31-31	GALLEY POWER- RIGHT AFT
25-25-23	IN SEAT POWER OUTLETS FORWARD CABIN
25-25-24	IN SEAT POWER OUTLETS MID CABIN
25-65-11	LEFT OFF-WING ESCAPE SYSTEM
25-29-12	MEDICAL OUTLETS
25-11-11	POWER SEAT- CAPTAIN
25-11-21	POWER SEAT- FIRST OFFICER
25-33-11	REFRIGERATION POWER
25-65-12	RIGHT OFF-WING ESCAPE SYSTEM
25-29-11	SERVICE OUTLETS

25-ALPHABETICAL INDEX

D280T132

Page 1
Jan 21/2005



767-200/300

WIRING DIAGRAM MANUAL

**CHAPTER 25
EQUIPMENT / FURNISHINGS**

CH-SC-SU	Title
25-42-11	SHAVER OUTLETS- LAVATORY

25-ALPHABETICAL INDEX

D280T132

Page 2
Jan 21/2005

-B
5

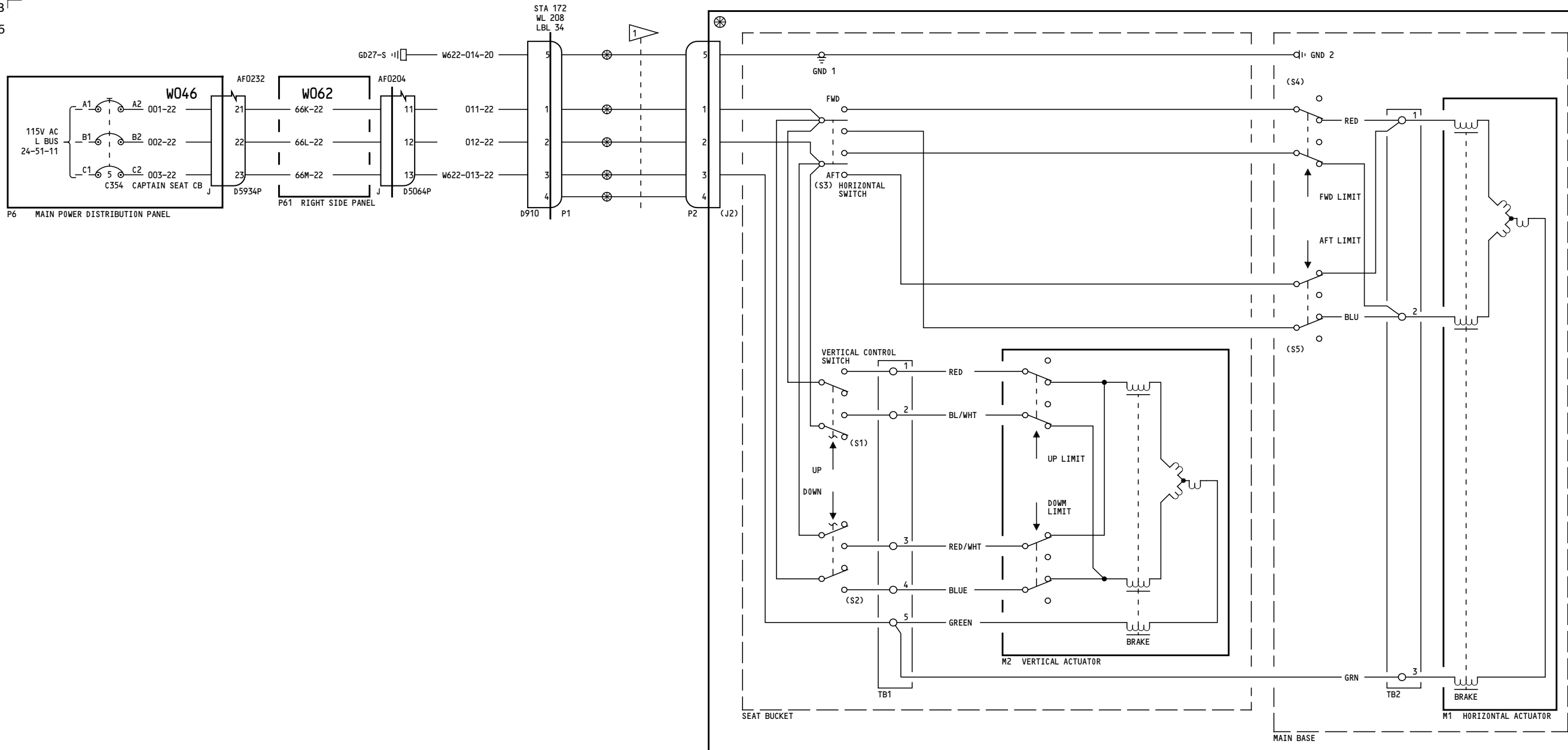

M1310(YGR) CAPTAIN POWER SEAT STA 187, LBL 21

NOTES:
1 SPRINGLOADED FLEXIBLE CABLE-PART OF M154

050-099	<p align="center">POWER SEAT- CAPTAIN</p> <p align="center">D280T132</p>
---------	---

25-11-11

Page 1

Jan 21/2005

25-11-11

Page 1

Jan 21/2005

-C
7

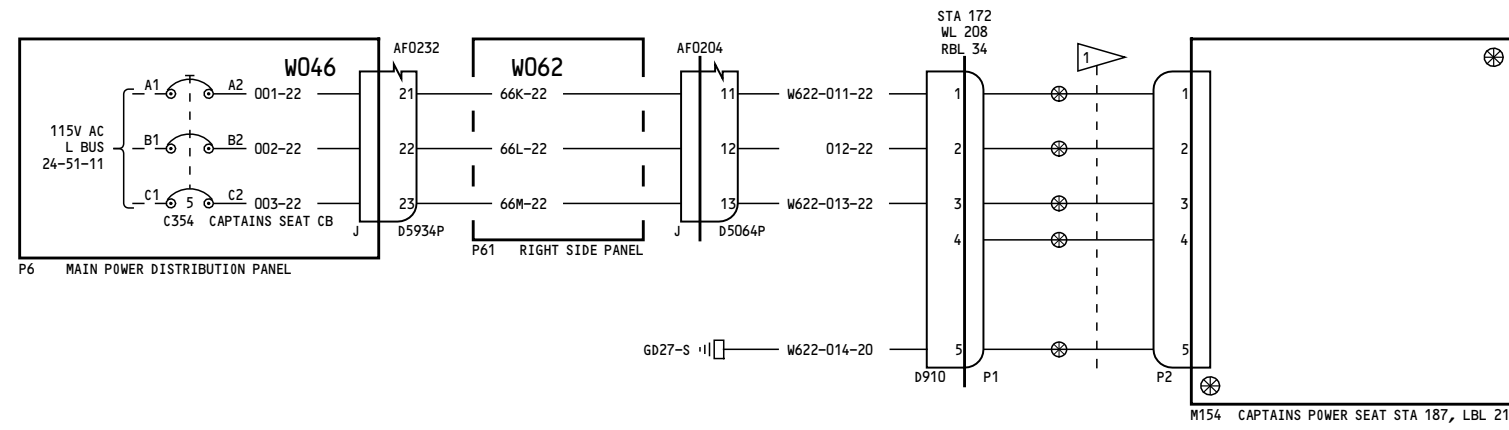

NOTES:
 1 SPRINGLOADED FLEXIBLE CABLE-PART OF M154

150-199, 275-299

**POWER SEAT-
CAPTAIN**

25-11-11

Page 2

D280T132

Jan 21/2005

25-11-11

Page 2

Jan 21/2005

-C
4

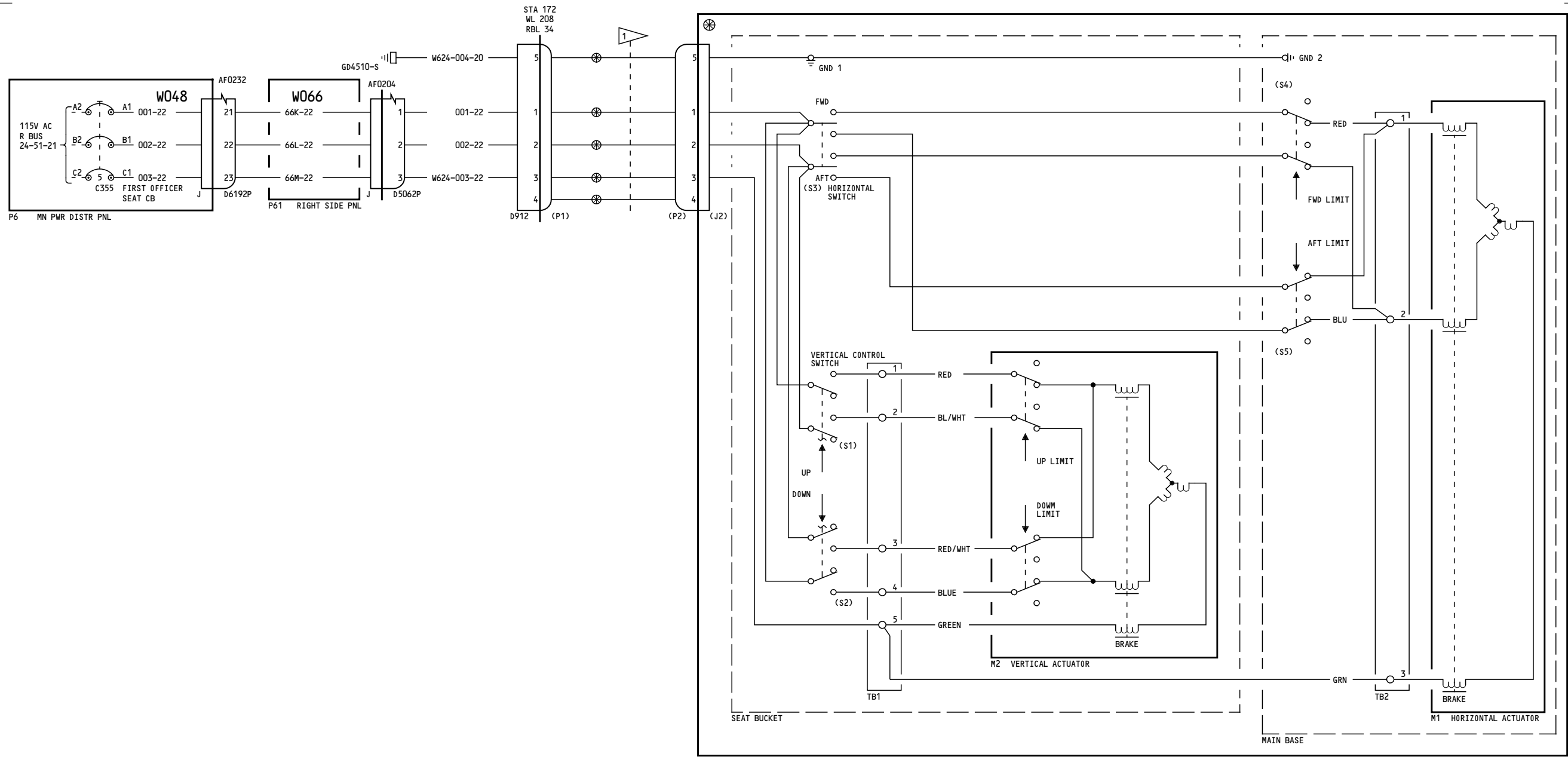

M1311(YGS) FIRST OFFICER POWER SEAT STA 187, RBL 21

NOTES:
1 SPRINGLOADED FLEXIBLE CABLE-PART OF M155

050-099

**POWER SEAT-
FIRST OFFICER**

D280T132

25-11-21

Page 1

Jan 21/2005

25-11-21

Page 1

Jan 21/2005

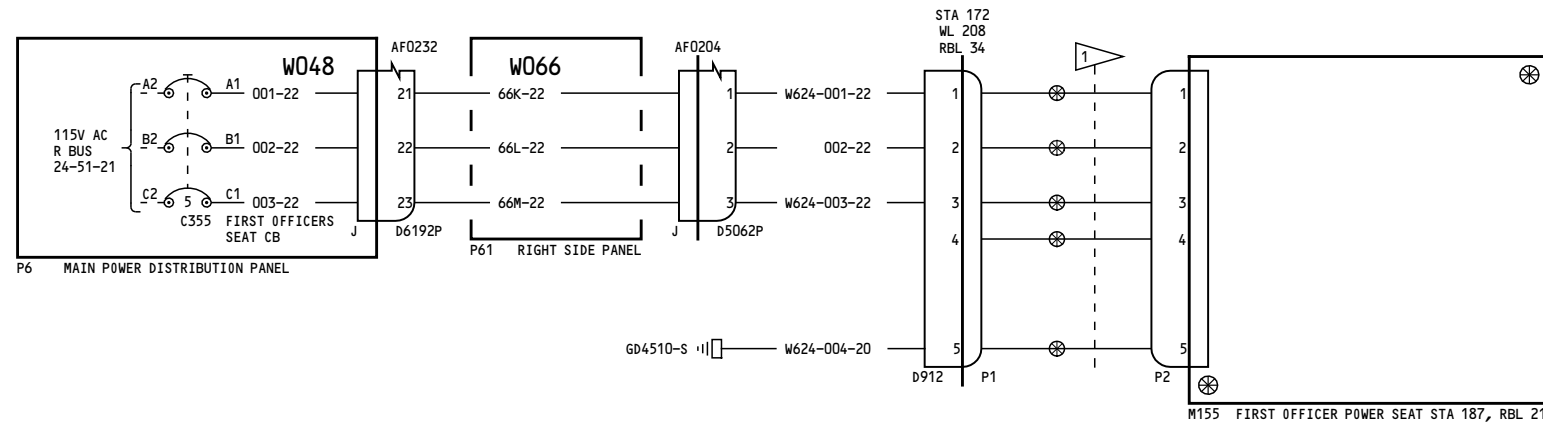

NOTES:
 1 SPRINGLOADED FLEXIBLE CABLE-PART OF M155

150-199, 275-299

**POWER SEAT-
FIRST OFFICER**

D280T132

25-11-21

Page 2

Jan 21/2005

25-11-21

Page 2

Jan 21/2005

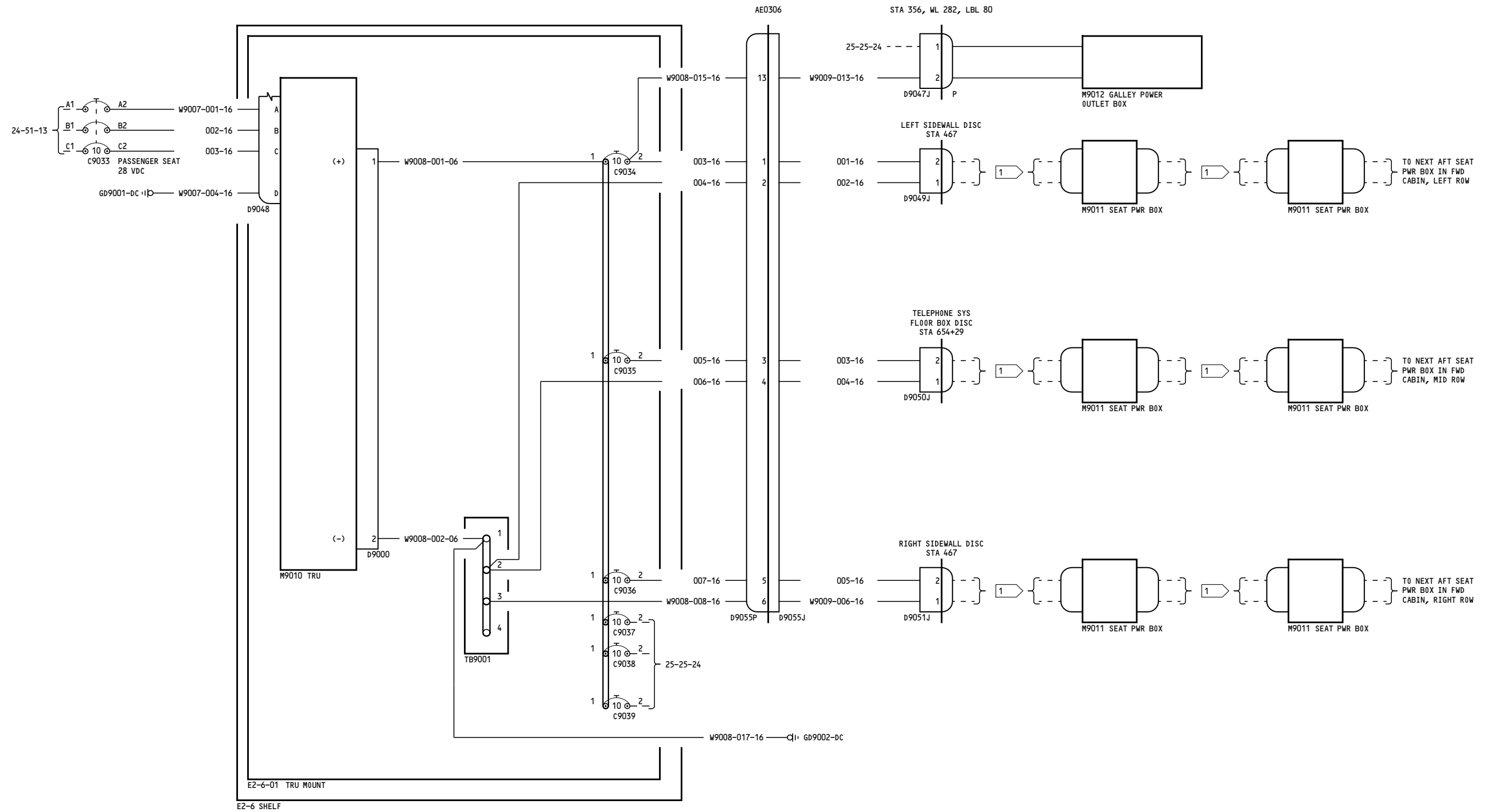

NOTES: SEAT-TO-SEAT CABLES
 1 P/N DA300713-1 EXCEPT BETWEEN ROW 2 AND 3:
 P/N DA300713-2

150, 153, 157

**IN SEAT POWER OUTLETS
 FORWARD CABIN**

25-25-23

Page 1A
 Sheet 1
 Jan 21/2005

D280T132

Incorporates
 EAD89-0704-00
 MTO 240500

25-25-23

Page 1A
 Sheet 1
 Jan 21/2005

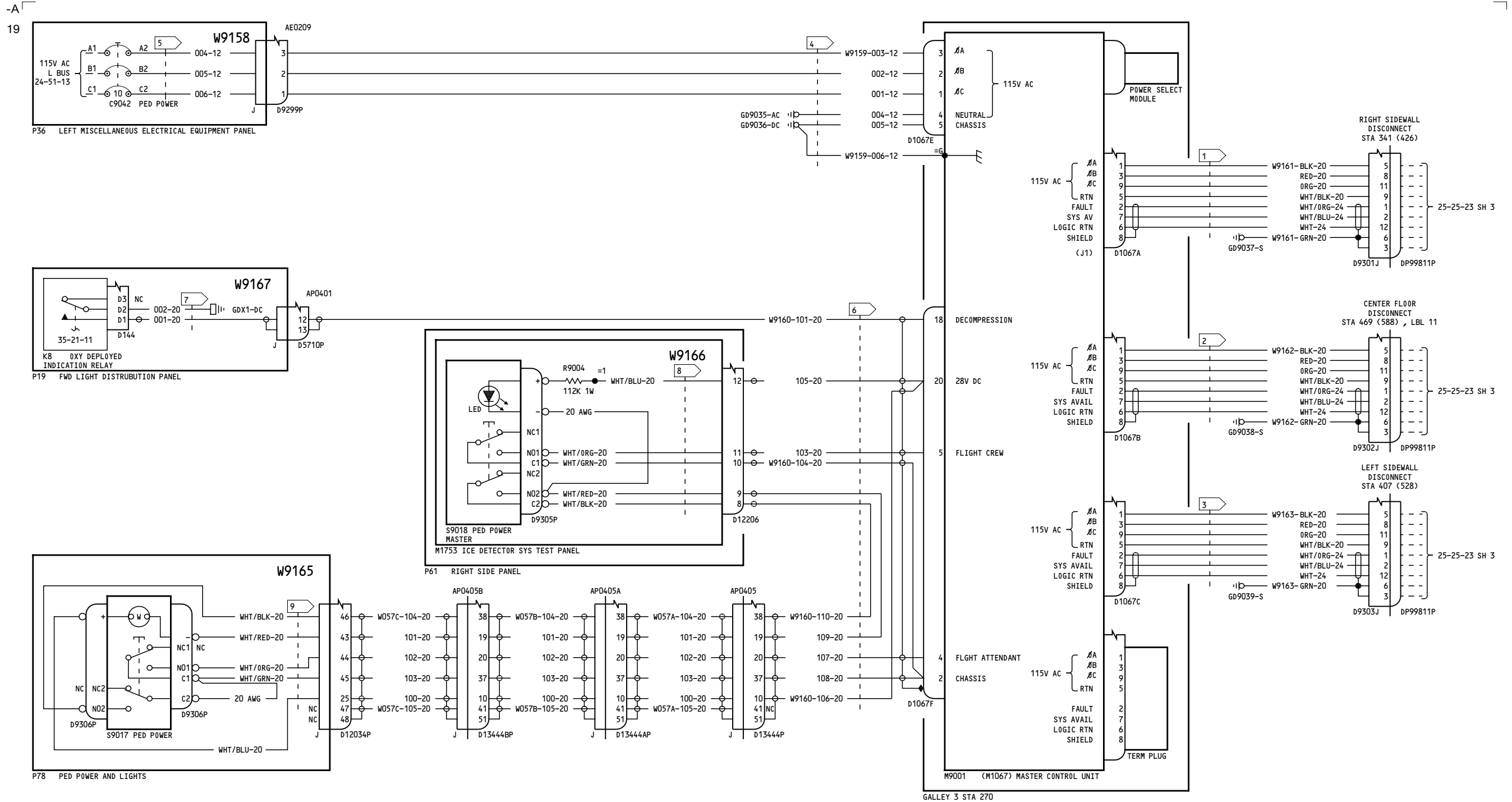

- 1 VENDOR CABLE PART 1133801-1
- 2 VENDOR CABLE PART 1133802-1
- 3 VENDOR CABLE PART 1133803-1
- 4 VENDOR CABLE PART 1133807-1
- 5 VENDOR CABLE PART 1133800-1
- 6 VENDOR CABLE PART 1133805-1
- 7 VENDOR CABLE PART 1133809-1
- 8 VENDOR CABLE PART 1133808-1
- 9 VENDOR CABLE PART 1133806-1

150, 153, 157

IN SEAT POWER OUTLETS FORWARD CABIN

D280T132

25-25-23

Page 1A
 Sheet 2
 Jan 21/2005

Incorporates
 EAD89-0704-00

25-25-23

Page 1A
 Sheet 2
 Jan 21/2005

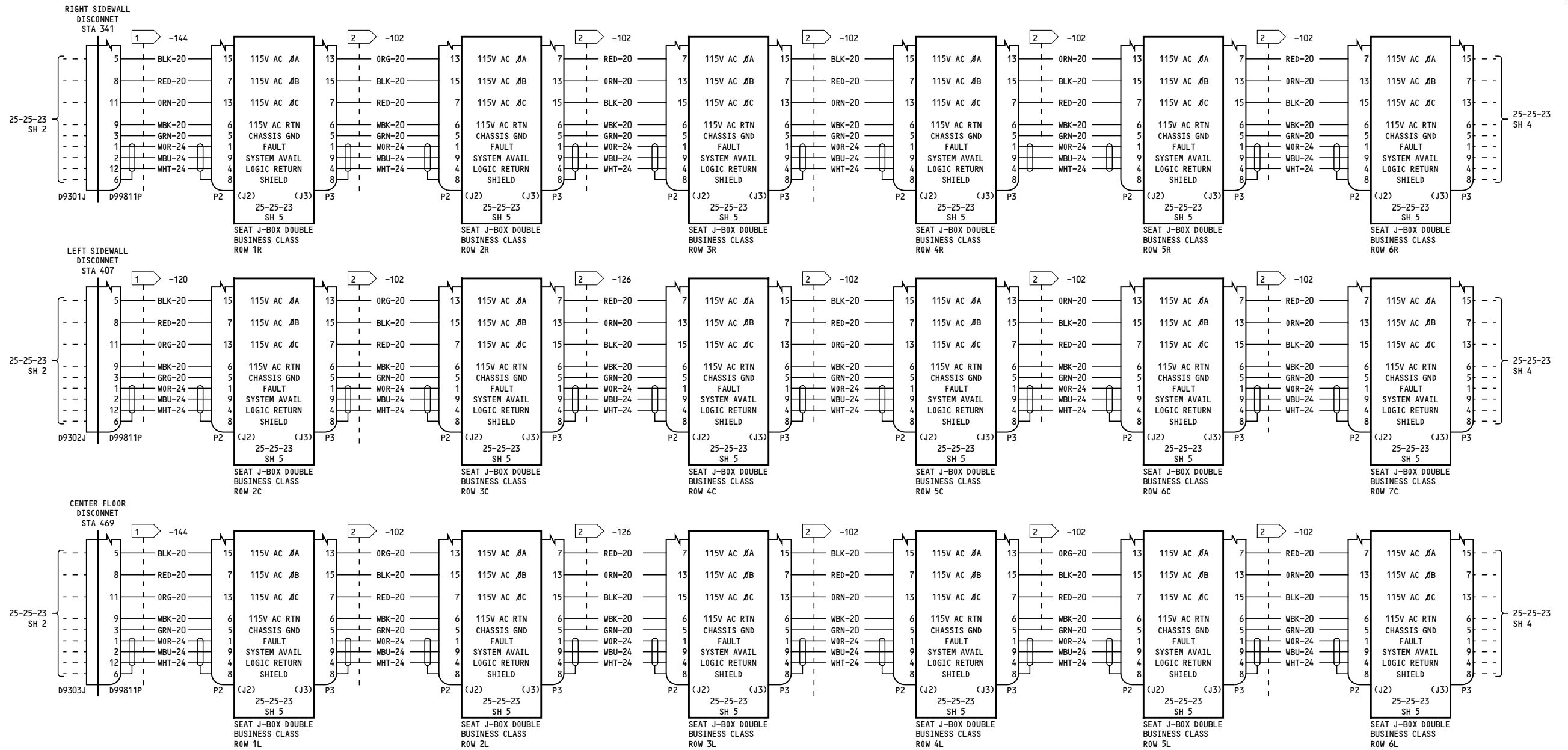

- NOTES:
- 1 VENDOR CABLE PART 1068807-1-XXX
 - 2 VENDOR CABLE PART 1068803-2-XXX

150, 153, 157

**IN SEAT POWER OUTLETS
FORWARD CABIN**

D280T132

25-25-23

Page 1A
Sheet 3
Jan 21/2005

Incorporates
EAD89-0704-00

25-25-23

Page 1A
Sheet 3
Jan 21/2005

1

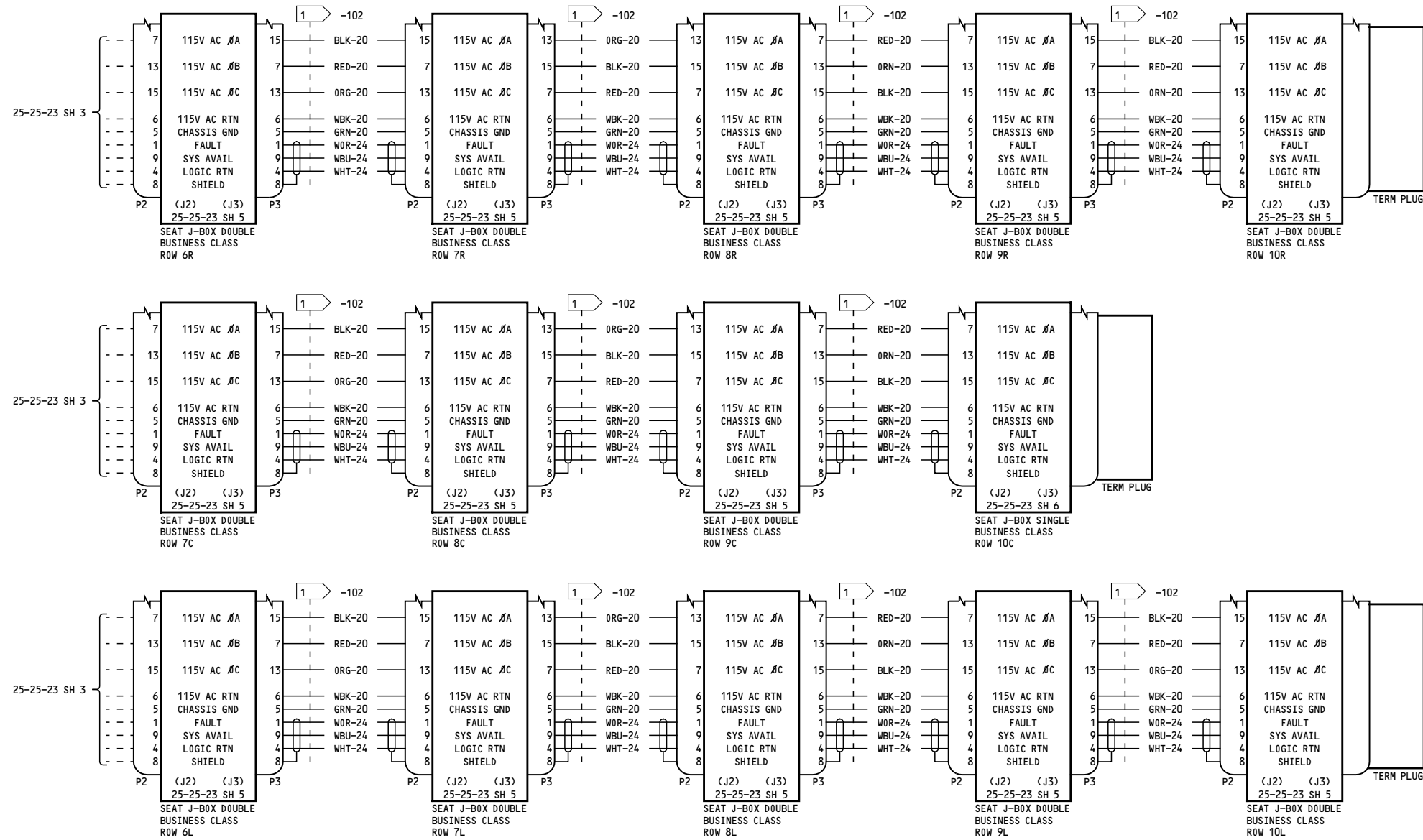

NOTES:
 1 VENDOR CABLE PART 1068803-2-102

150, 153, 157

**IN SEAT POWER OUTLETS
 FORWARD CABIN**

25-25-23

Page 1A
 Sheet 4
 Jan 21/2005

D280T132

Incorporates
 EAD89-0704-00

25-25-23

Page 1A
 Sheet 4
 Jan 21/2005

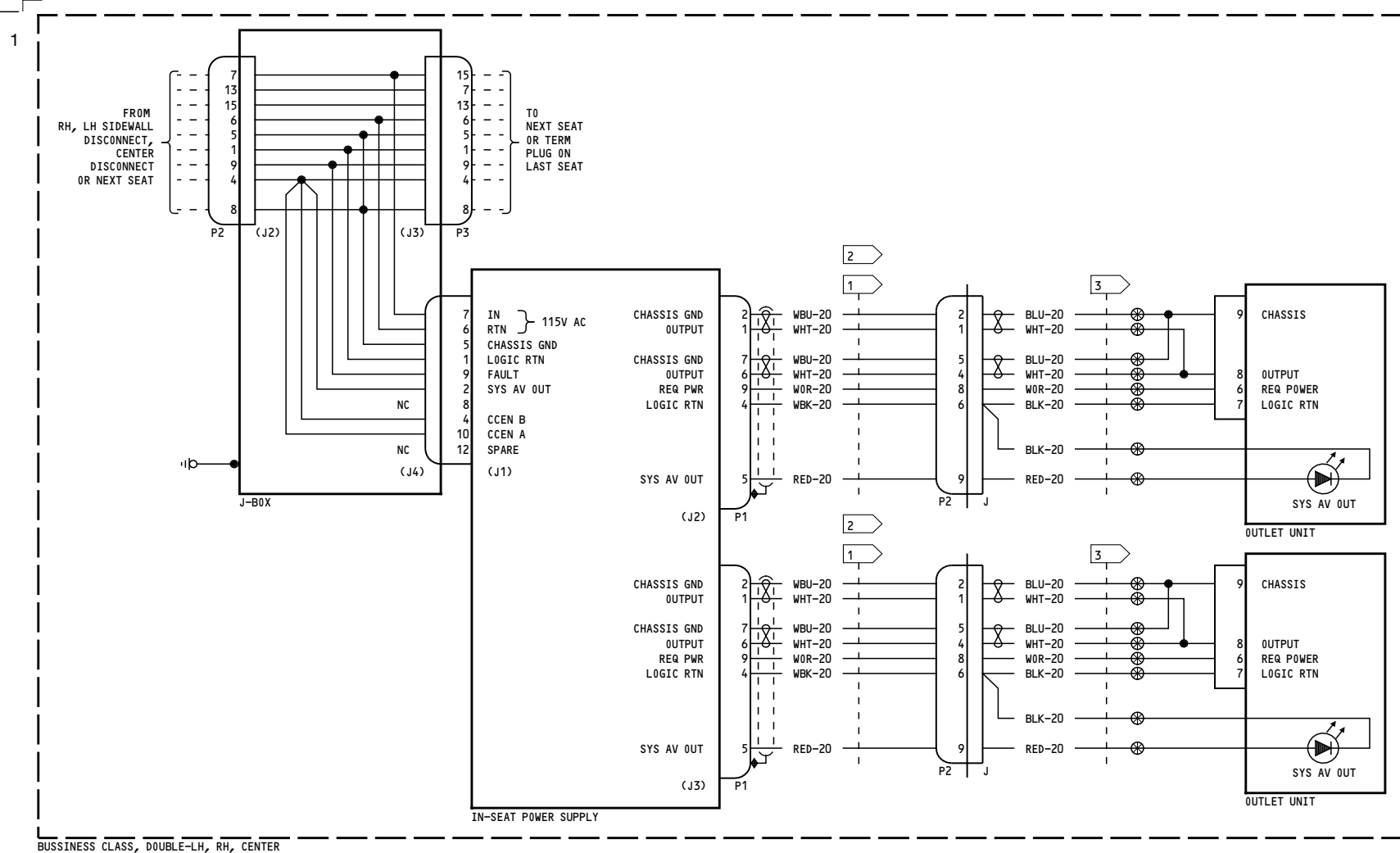

- NOTES:
- 1) VENDOR CABLE PART 1068805-5-42
 - 2) ALTERNATE CABLE PART 1068805-5-96
 - 3) VENDOR CABLE PART 1075-2-8

150, 153, 157

**IN SEAT POWER OUTLETS
FORWARD CABIN**

D280T132

25-25-23

Page 1A
Sheet 5
Jan 21/2005

Incorporates
EAD89-0704-00

25-25-23

Page 1A
Sheet 5
Jan 21/2005

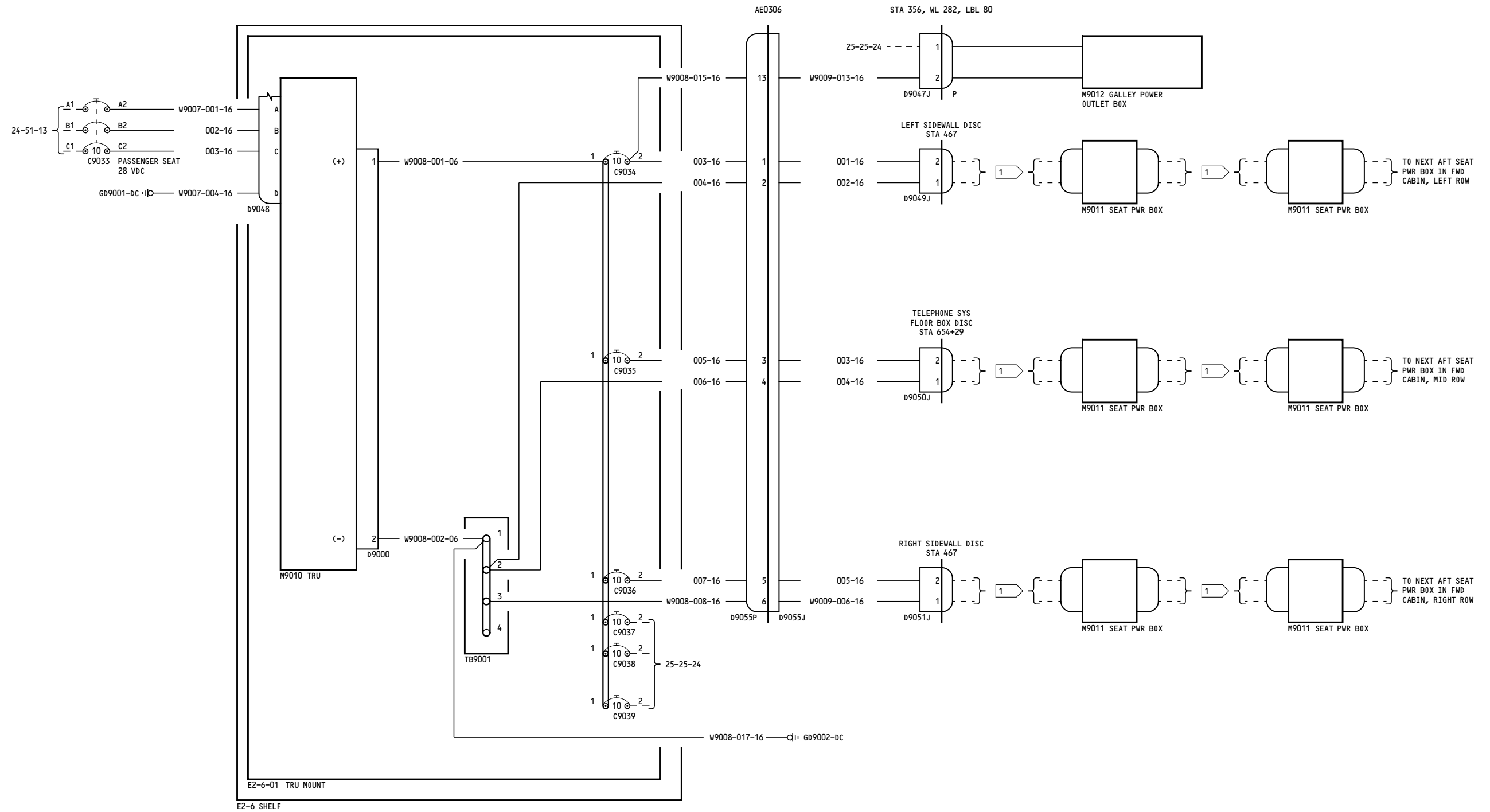

NOTES: SEAT-TO-SEAT CABLES
 1 P/N DA300713-1 EXCEPT BETWEEN ROW 2 AND 3:
 P/N DA300713-2

154-156, 162-164	<p>IN SEAT POWER OUTLETS FORWARD CABIN</p> <p>25-25-23</p> <p>Page 2A</p> <p>D280T132</p> <p>Jan 21/2005</p>
------------------	--

Incorporates
 MTO 240500

25-25-23

Page 2A

Jan 21/2005

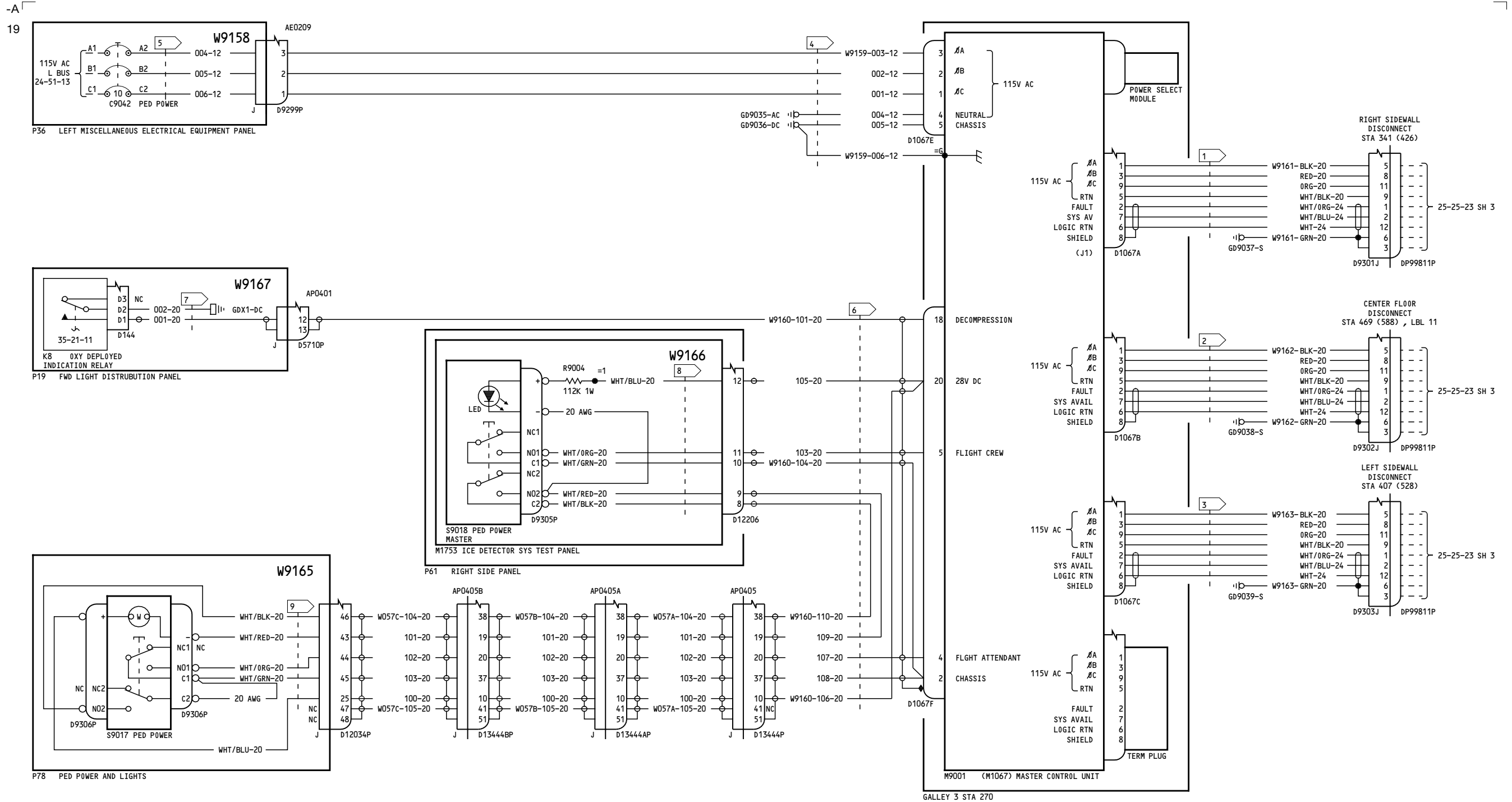

- | | | | | | |
|---|-----------------------------|---|-----------------------------|---|-----------------------------|
| 1 | VENDOR CABLE PART 1133801-1 | 4 | VENDOR CABLE PART 1133807-1 | 7 | VENDOR CABLE PART 1133809-1 |
| 2 | VENDOR CABLE PART 1133802-1 | 5 | VENDOR CABLE PART 1133800-1 | 8 | VENDOR CABLE PART 1133808-1 |
| 3 | VENDOR CABLE PART 1133803-1 | 6 | VENDOR CABLE PART 1133805-1 | 9 | VENDOR CABLE PART 1133806-1 |

165-167

IN SEAT POWER OUTLETS FORWARD CABIN

D280T132

25-25-23

Page 3A
Sheet 2
Jan 21/2005

Incorporates
EAD89-0704-00

25-25-23

Page 3A
Sheet 2
Jan 21/2005

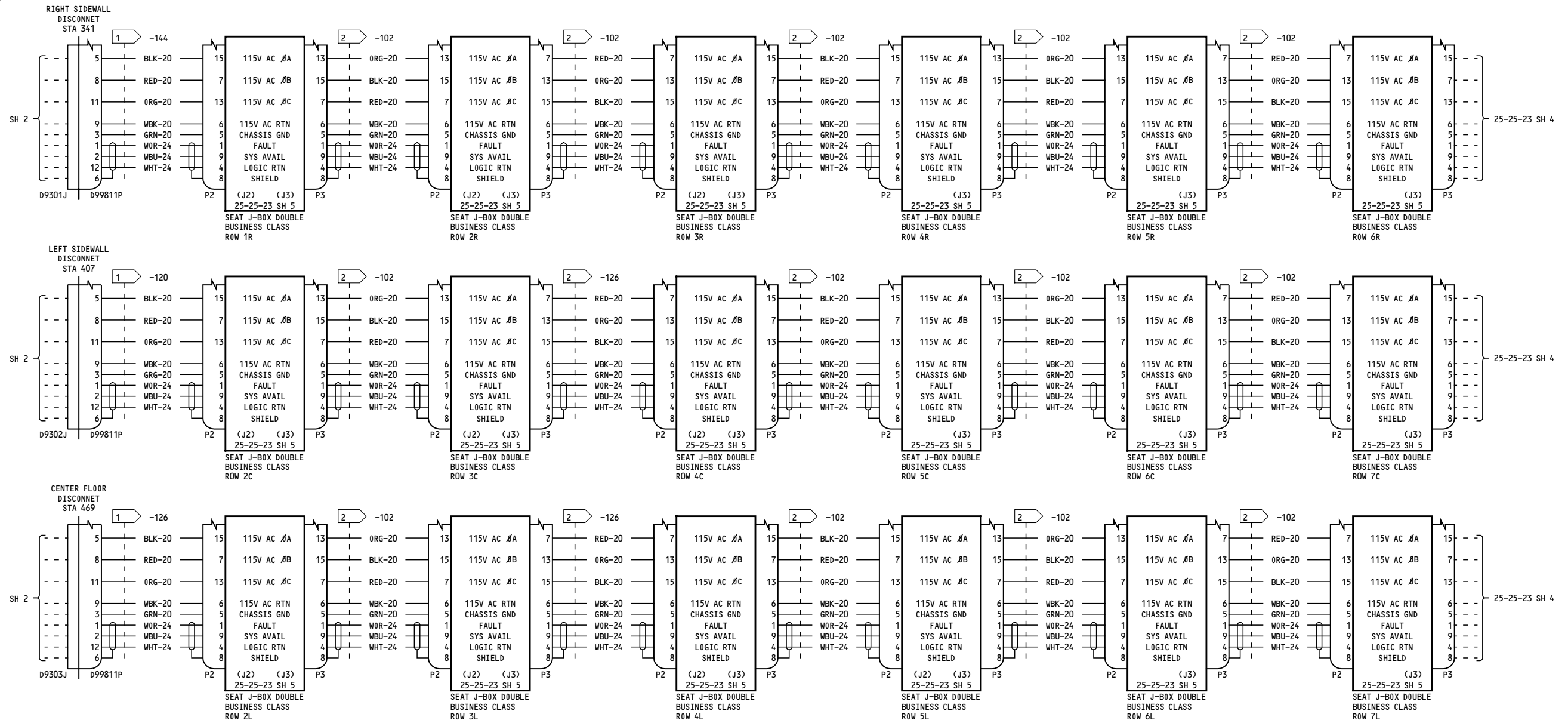

- NOTES:
- 1 VENDOR CABLE PART 1068807-1-XXX
 - 2 VENDOR CABLE PART 1068803-2-XXX

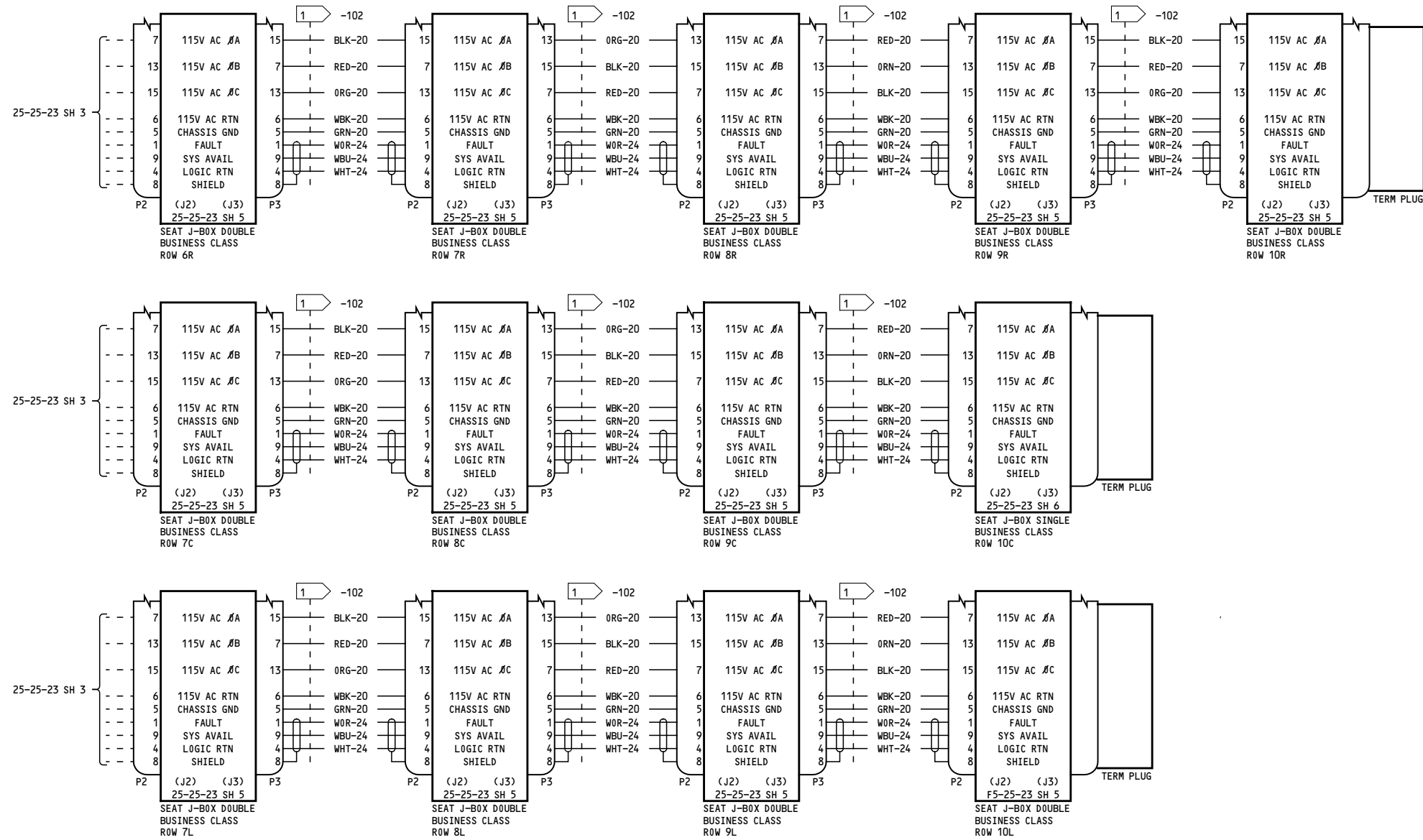

NOTES:
 1 VENDOR CABLE PART 1068803-2-102

165-167

**IN SEAT POWER OUTLETS
 FORWARD CABIN**

D280T132

25-25-23

Page 3A
 Sheet 4
 Jan 21/2005

Incorporates
 EAD89-0704-00

25-25-23

Page 3A
 Sheet 4
 Jan 21/2005

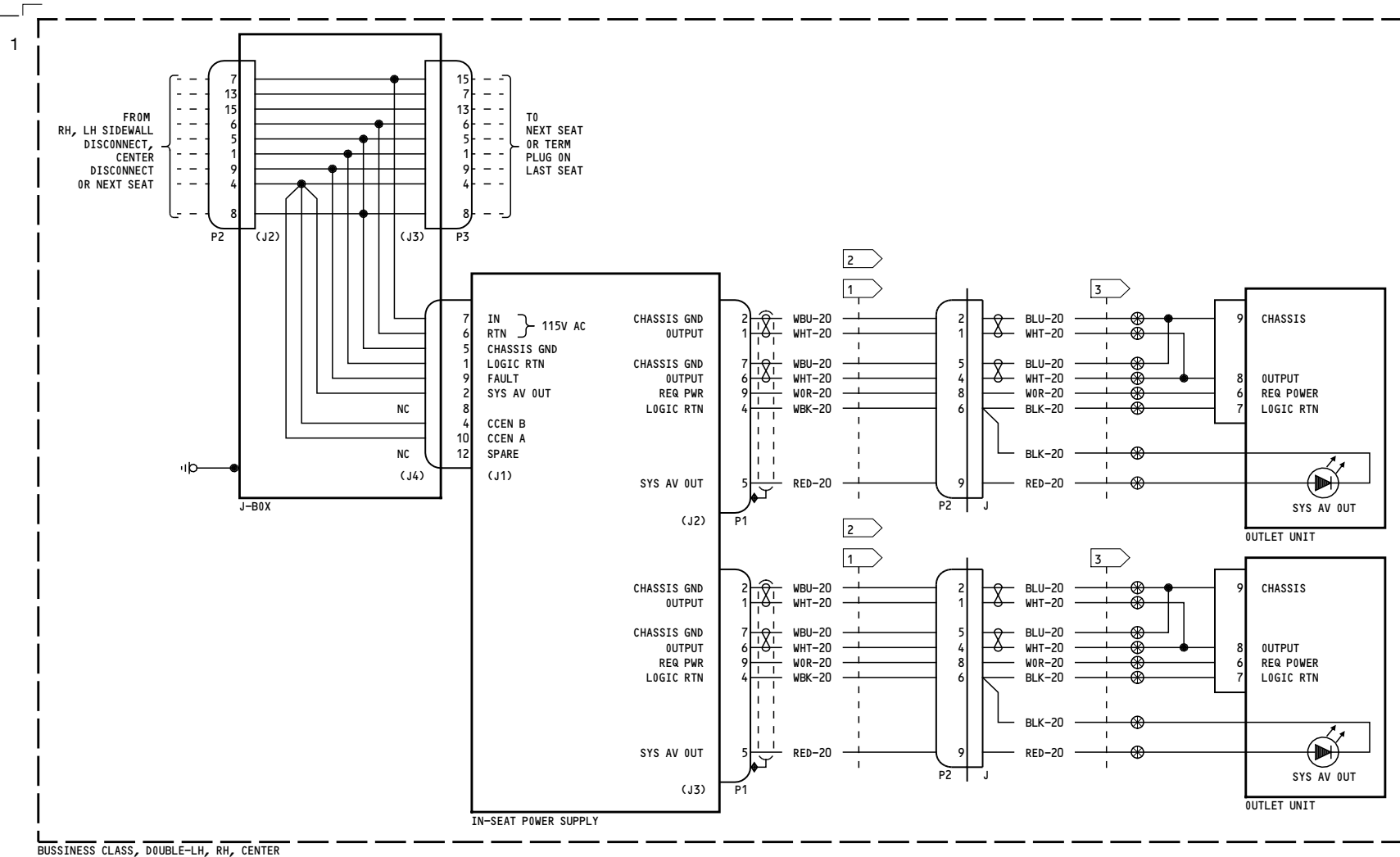

NOTES:

- 1 VENDOR CABLE PART 1068805-5-42
- 2 ALTERNATE CABLE PART 1068805-5-96
- 3 VENDOR CABLE PART 1075-2-8

165-167

**IN SEAT POWER OUTLETS
FORWARD CABIN**

D280T132

25-25-23

Page 3A
Sheet 5
Jan 21/2005

Incorporates
EAD89-0704-00

25-25-23

Page 3A
Sheet 5
Jan 21/2005

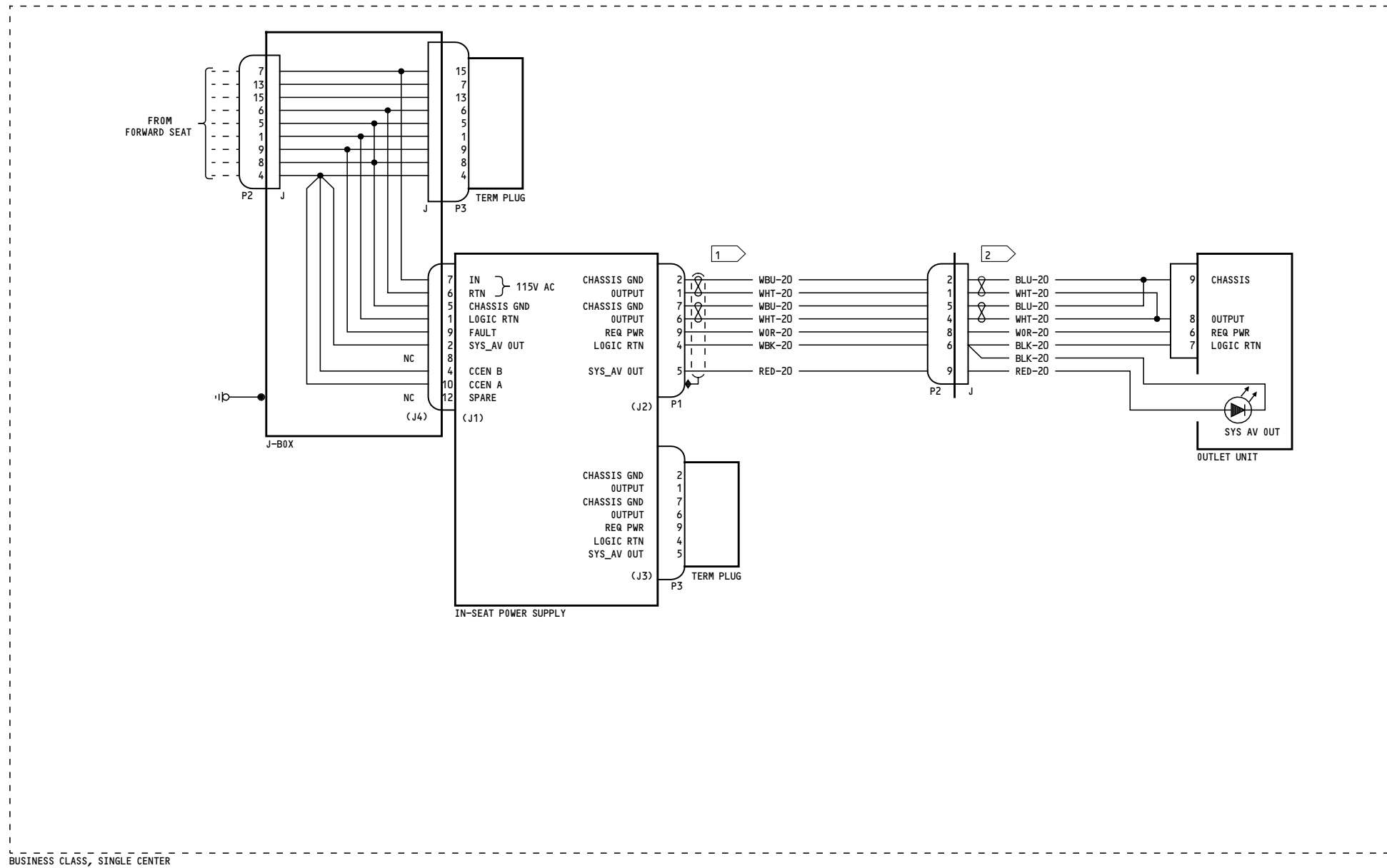

BUSINESS CLASS, SINGLE CENTER

NOTES:

1 VENDOR CABLE PART 1068805-5-42

2 VENDOR CABLE PART 1075-2-8

165-167

**IN SEAT POWER OUTLETS
FORWARD CABIN**

D280T132

25-25-23

Page 3A
Sheet 6
Jan 21/2005

Incorporates
EAD89-0704-00

25-25-23

Page 3A
Sheet 6
Jan 21/2005

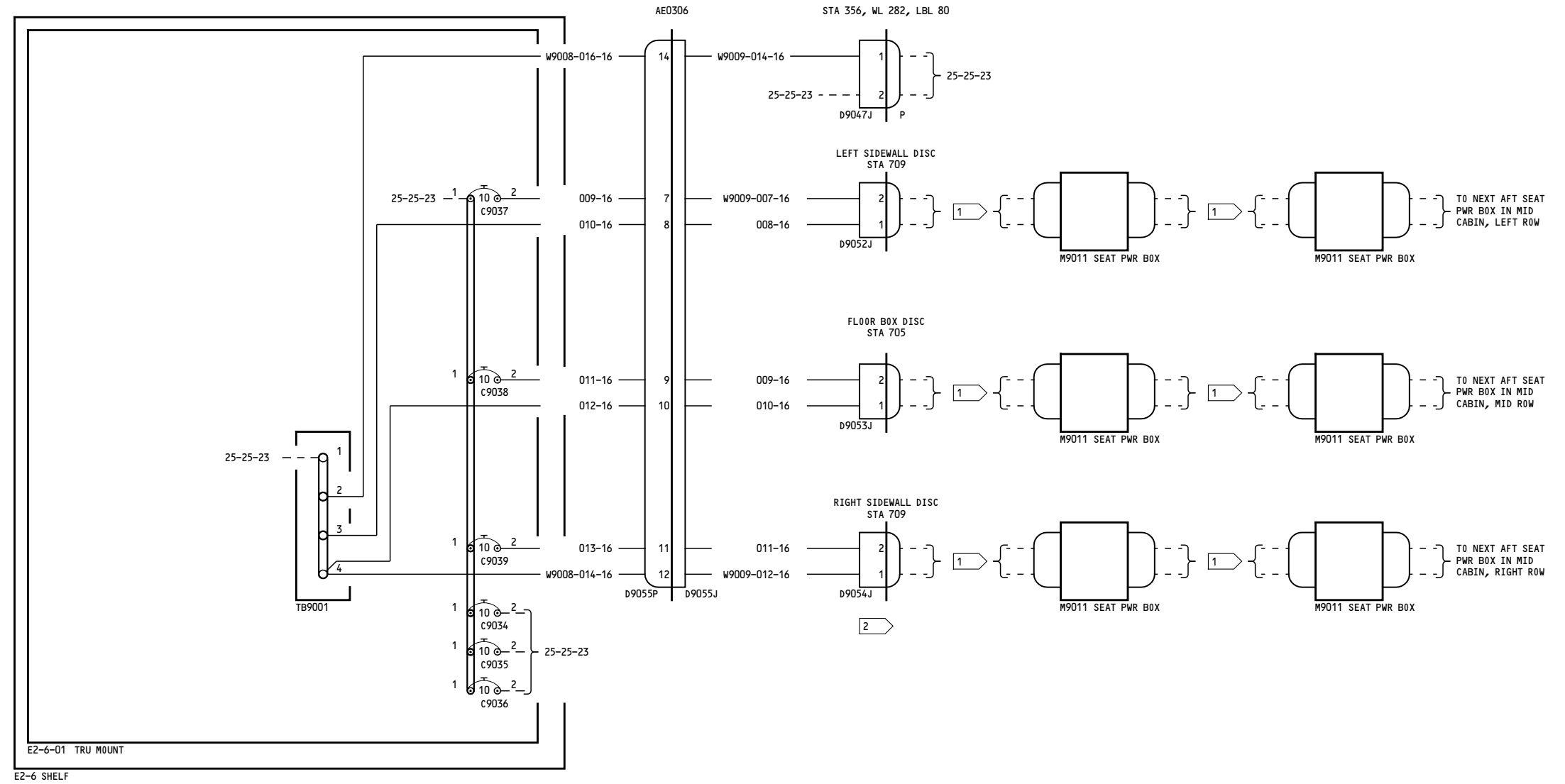

NOTES:
 SEAT-TO-SEAT CABLES
 1 P/N DA300713-1 EXCEPT BETWEEN ROW 2 AND 3:
 P/N DA300713-2
 2 D9049J-D9054J POLARIZATION
 PIN 1= NEGATIVE
 PIN 2= POSITIVE

150, 153-167

**IN SEAT POWER OUTLETS
 MID CABIN**

25-25-24

Page 1A

Jan 21/2005

D280T132

Incorporates
 MTO 240500

25-25-24

Page 1A

Jan 21/2005

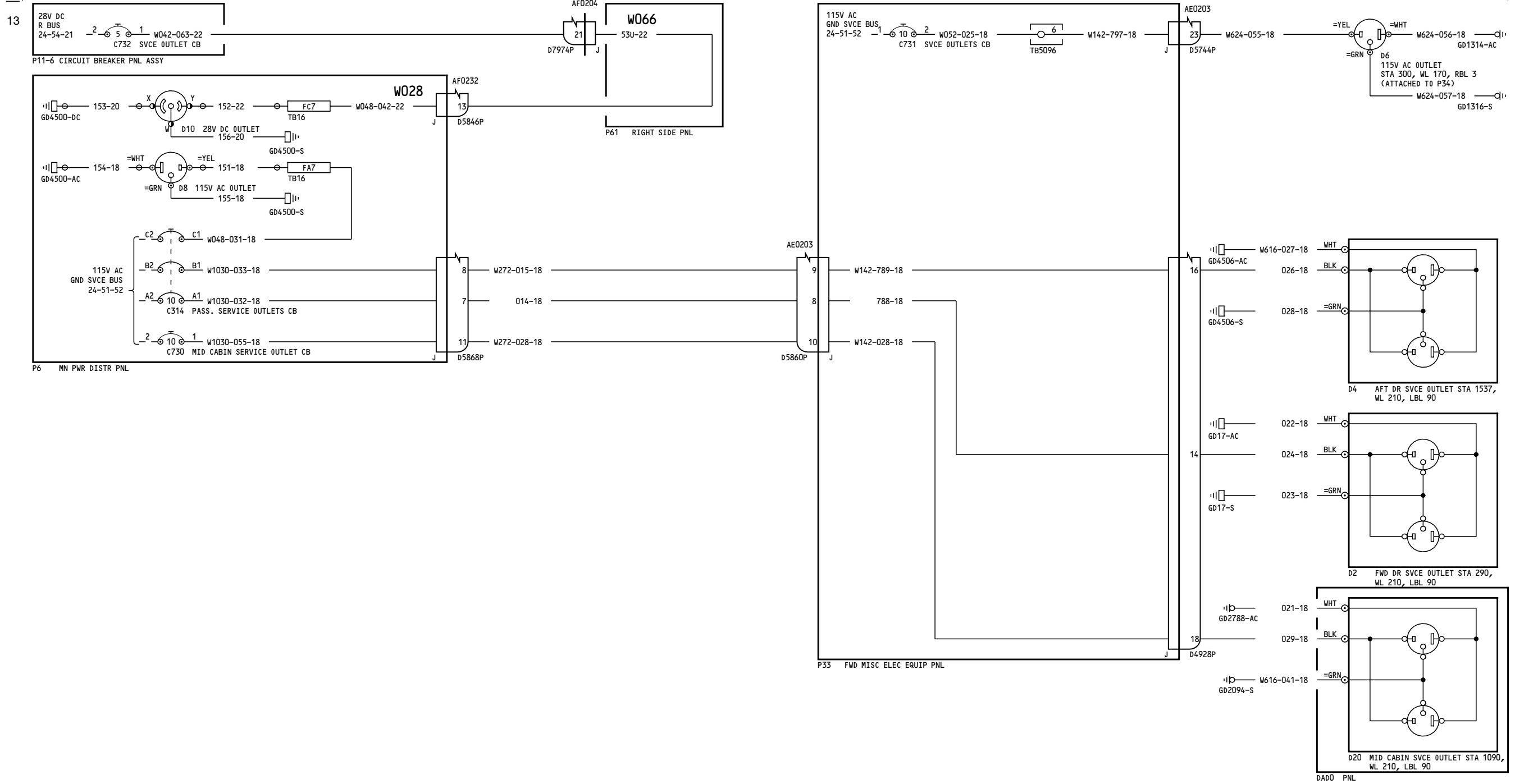

050-099

SERVICE OUTLETS

25-29-11

Page 1

D280T132

Jan 21/2005

25-29-11

Page 1

Jan 21/2005

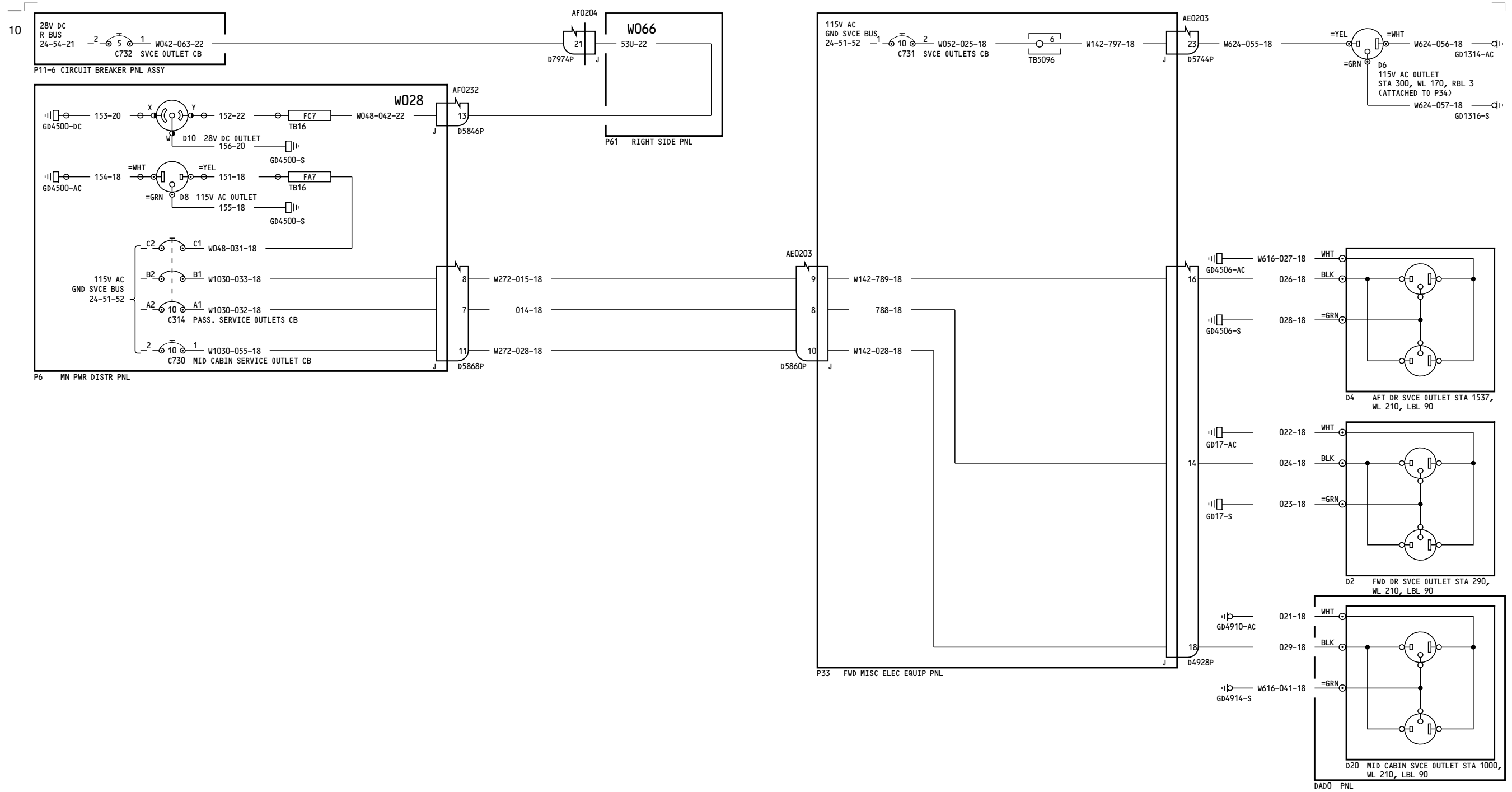

150-199, 275-299

SERVICE OUTLETS

25-29-11

Page 2

D280T132

Jan 21/2005

25-29-11

Page 2

Jan 21/2005

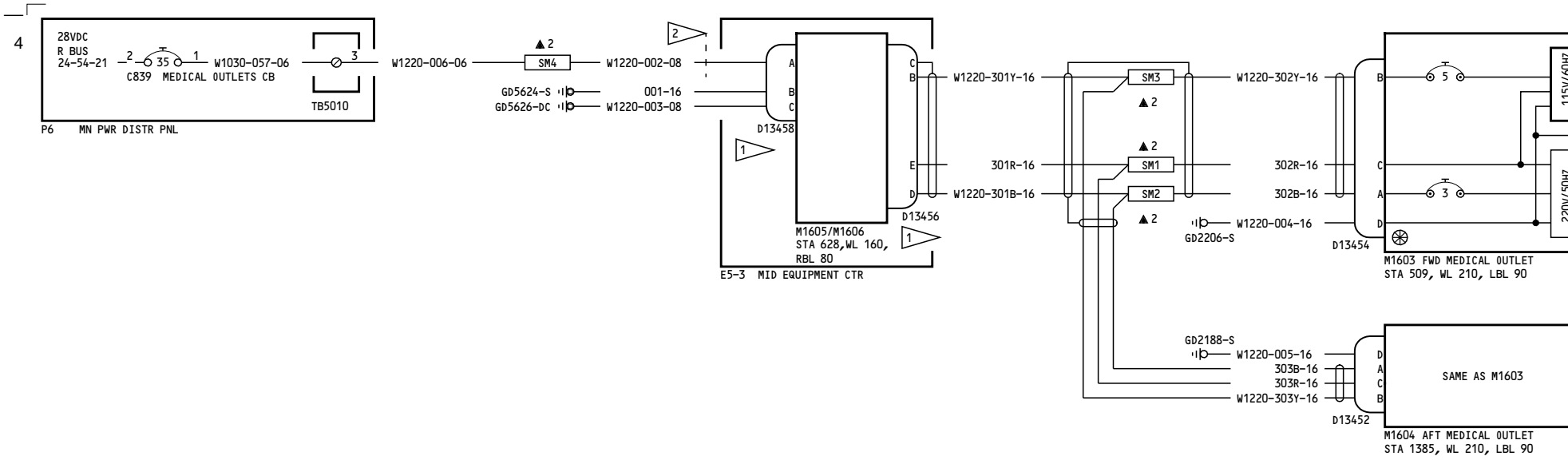

- NOTES:
- 1 CAP & STOW WHEN M1605/M1606 NOT INSTALLED
 - 2 MAXIMUM CRITICAL LENGTH 18 INCHES

050-099	<p style="text-align: center;">MEDICAL OUTLETS</p> <p style="text-align: center;">D280T132</p>
---------	---

25-29-12

Page 1

Jan 21/2005

25-29-12

Page 1

Jan 21/2005

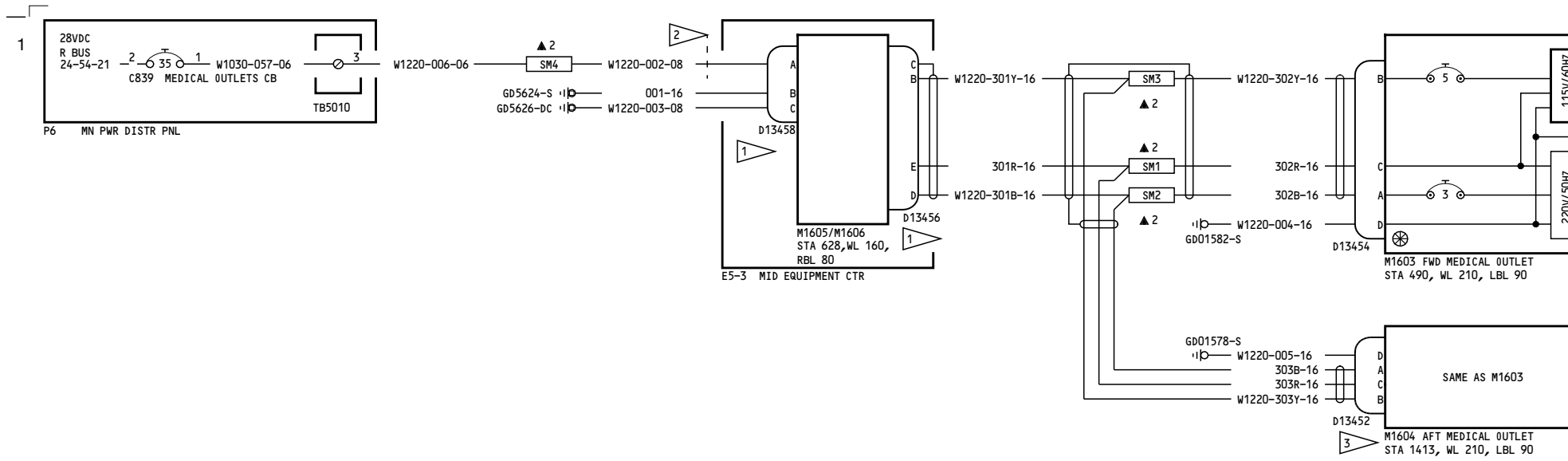

NOTES:

- 1 CAP & STOW WHEN M1605/M1606 NOT INSTALLED
- 2 MAXIMUM CRITICAL LENGTH 18 INCHES
- 3 M1604 IS AT STA 1379 FOR VN163-VN170

150-199

MEDICAL OUTLETS

D280T132

25-29-12

Page 2

Jan 21/2005

25-29-12

Page 2

Jan 21/2005

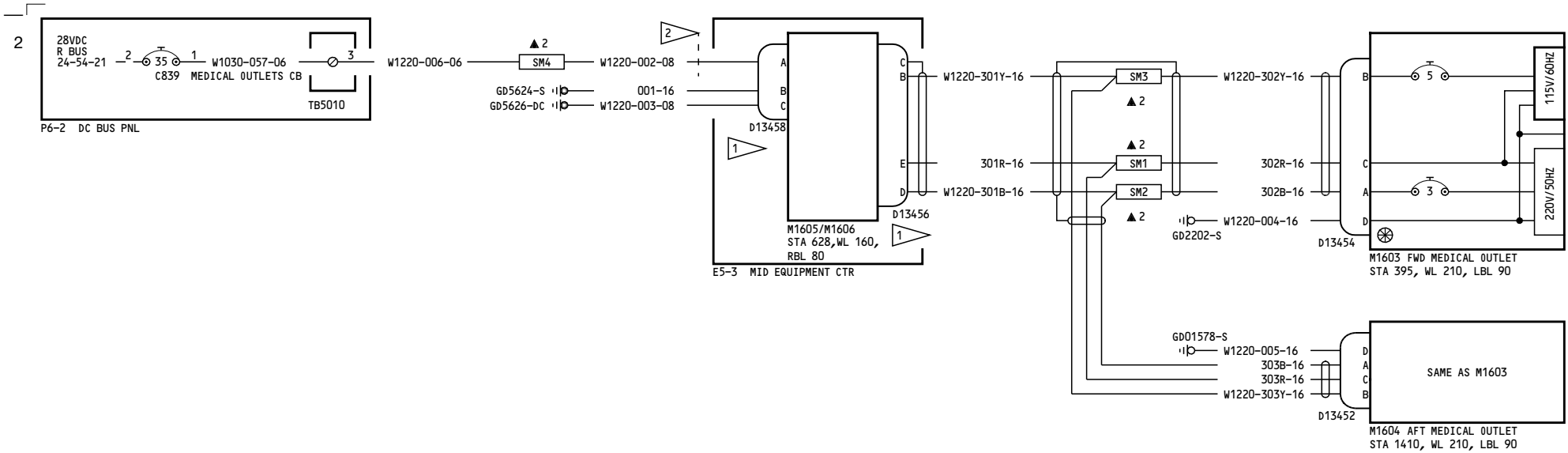

- NOTES:
- 1 CAP & STOW WHEN M1605/M1606 NOT INSTALLED
 - 2 MAXIMUM CRITICAL LENGTH 18 INCHES

275-299

MEDICAL OUTLETS

D280T132

25-29-12

Page 3

Jan 21/2005

25-29-12

Page 3

Jan 21/2005

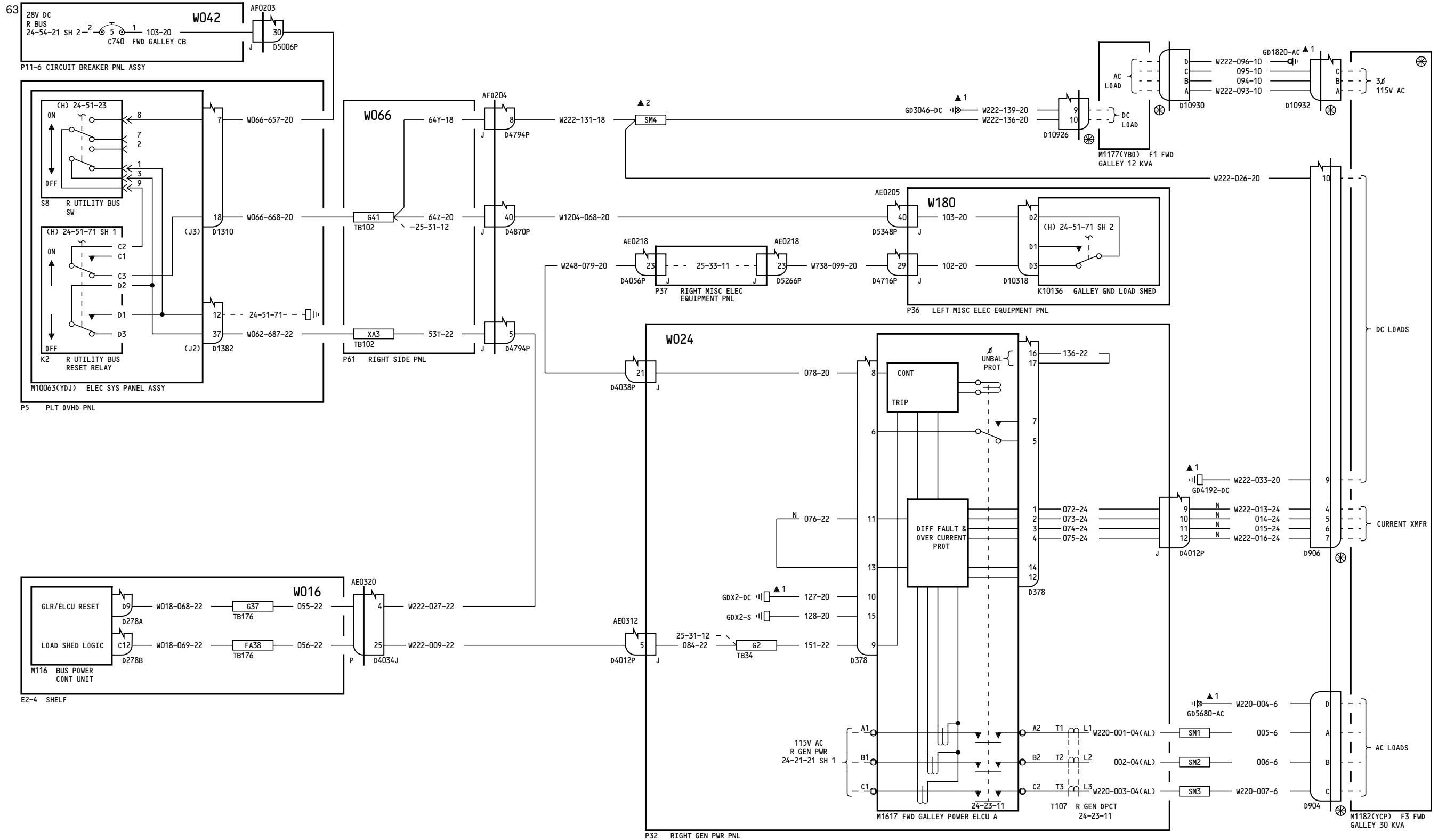

050-099

GALLEY POWER-FORWARD

25-31-11

Page 1

Jan 21/2005

D280T132

25-31-11

Page 1

Jan 21/2005

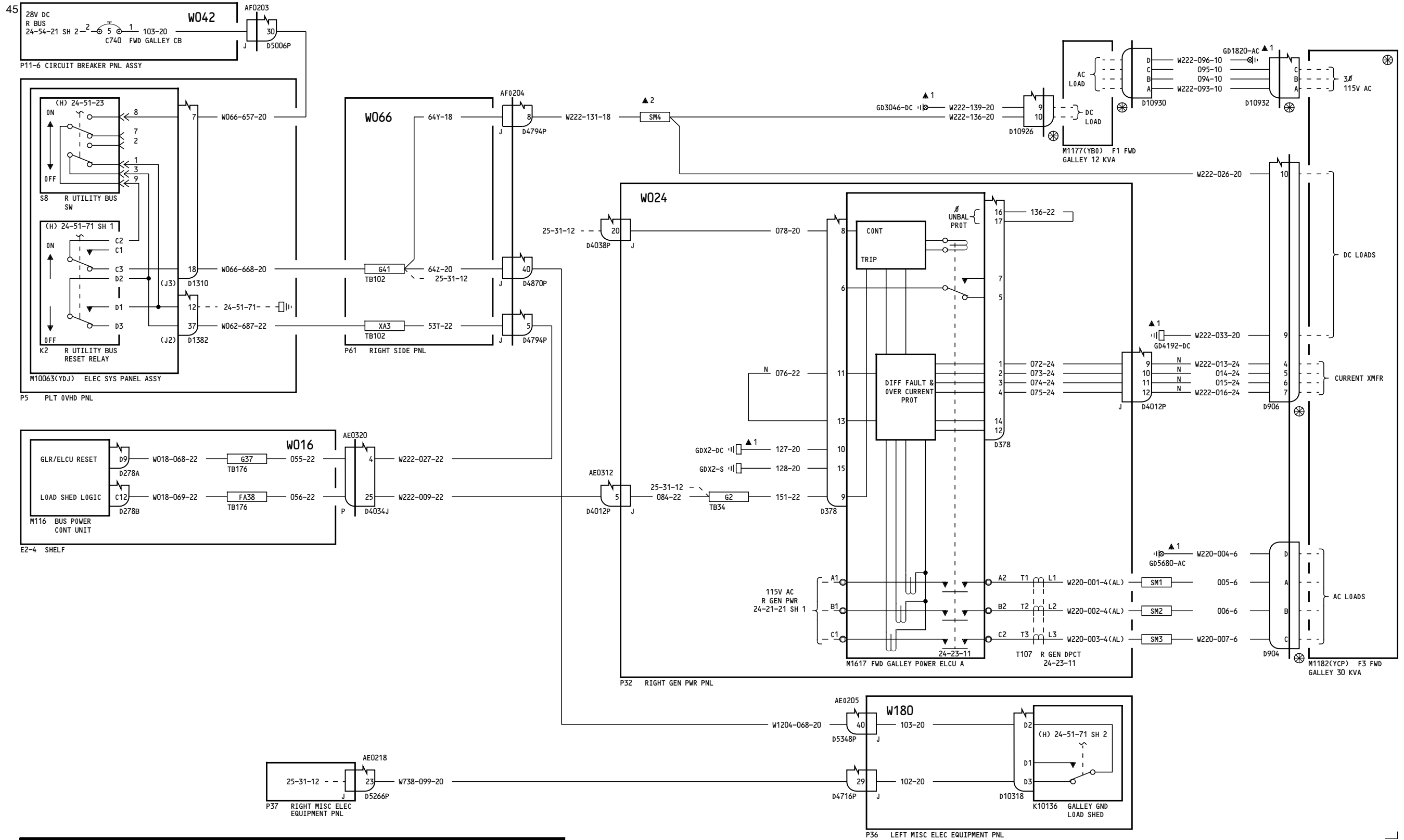

150-154

GALLEY POWER-FORWARD
D280T132

25-31-11

Page 2

Jan 21/2005

25-31-11

Page 2

Jan 21/2005

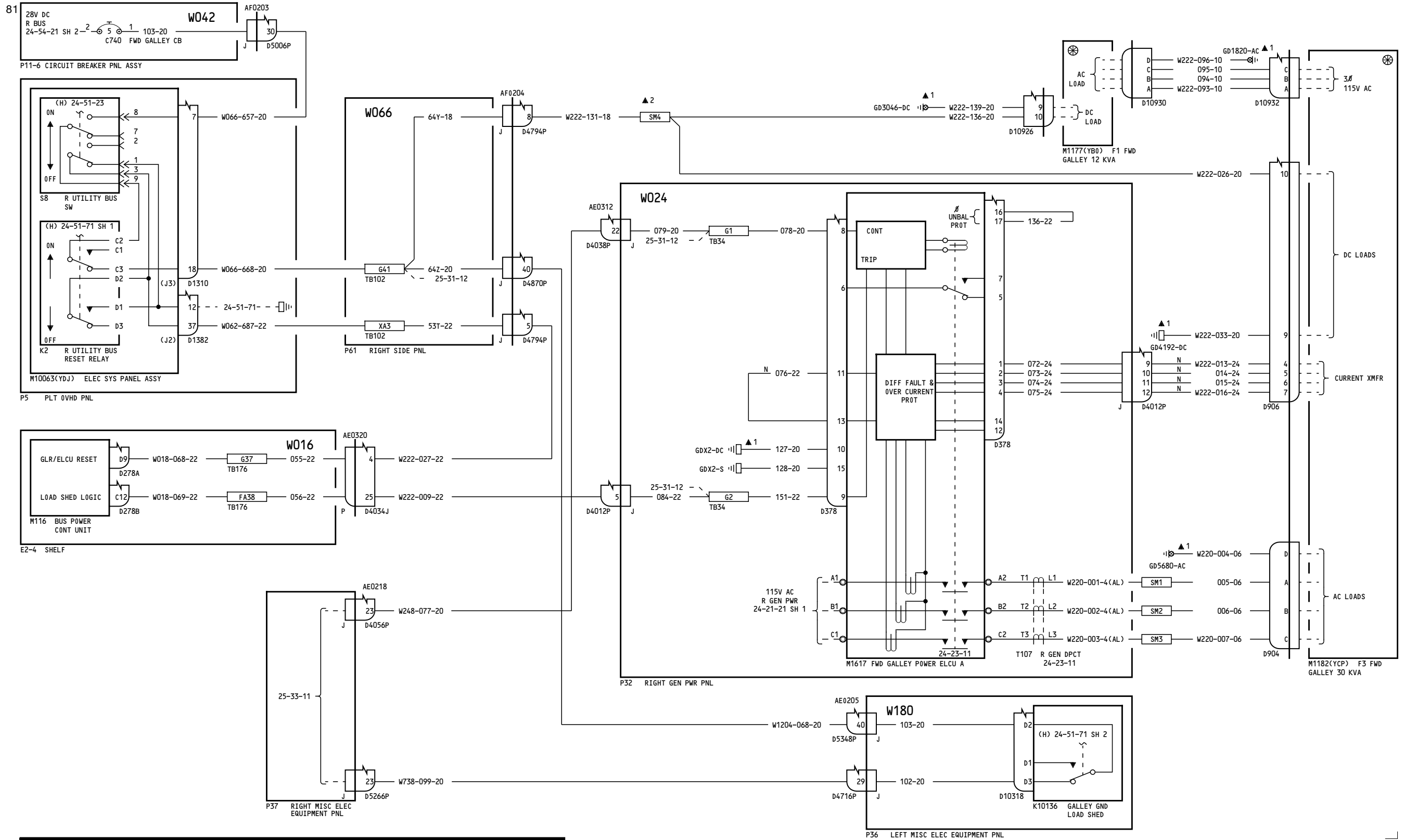

155-199

GALLEY POWER-FORWARD

25-31-11

Page 3

Jan 21/2005

D280T132

25-31-11

Page 3

Jan 21/2005

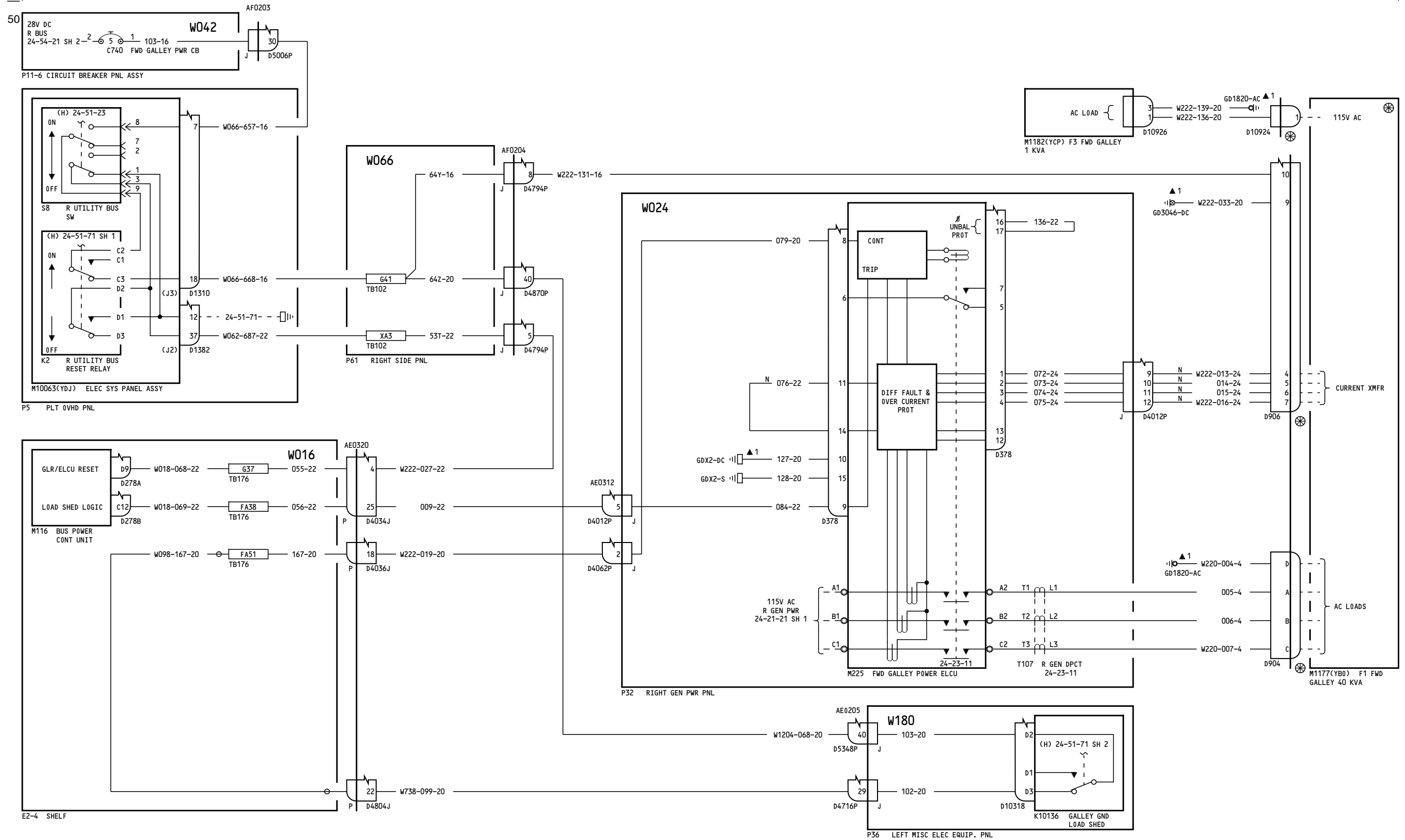

275-276

GALLEY POWER-FORWARD

25-31-11

Page 4

D280T132

Jan 21/2005

25-31-11

Page 4

Jan 21/2005

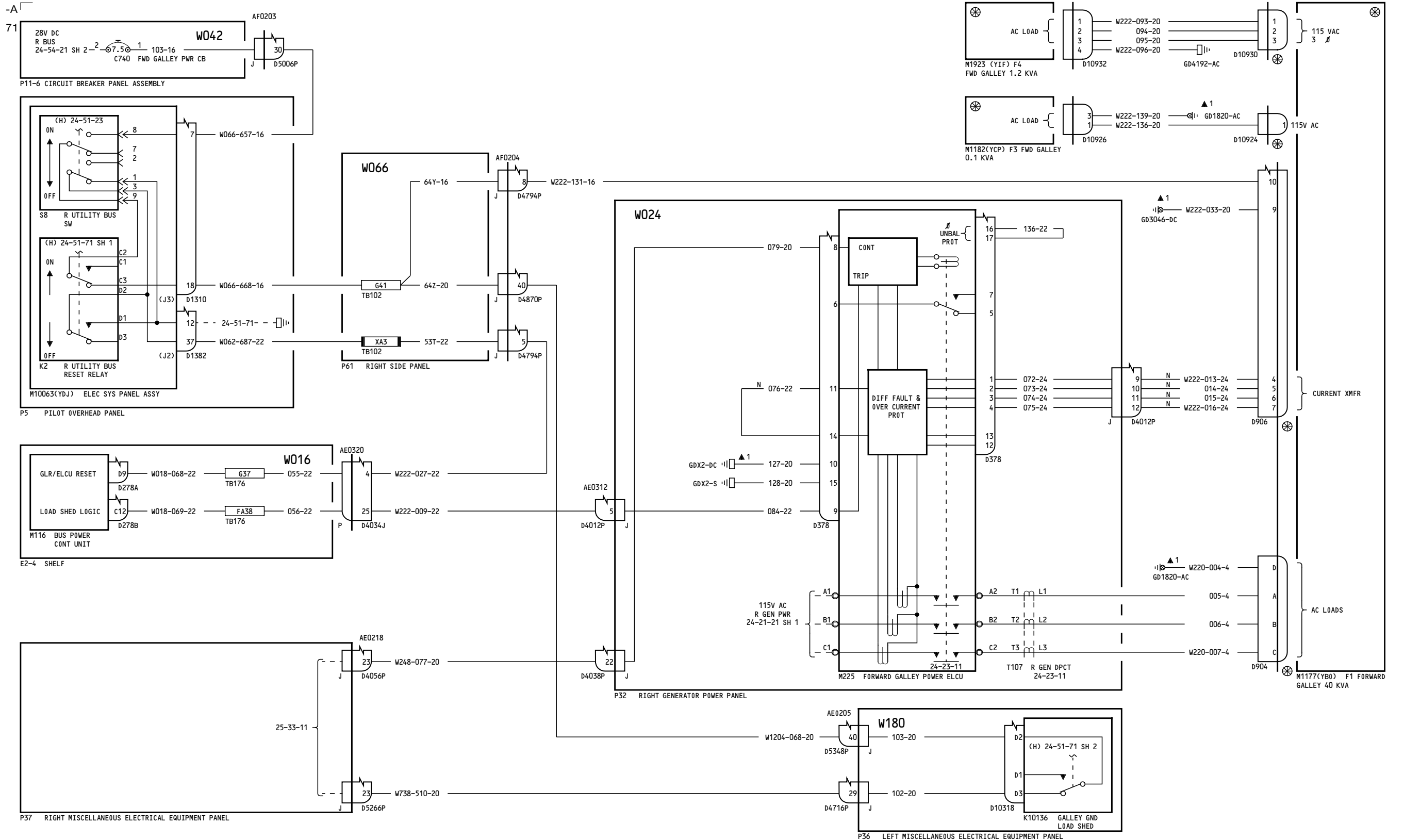

277-278

GALLEY POWER-FORWARD
D280T132

25-31-11
Page 5
Jan 21/2005

25-31-11
Page 5
Jan 21/2005

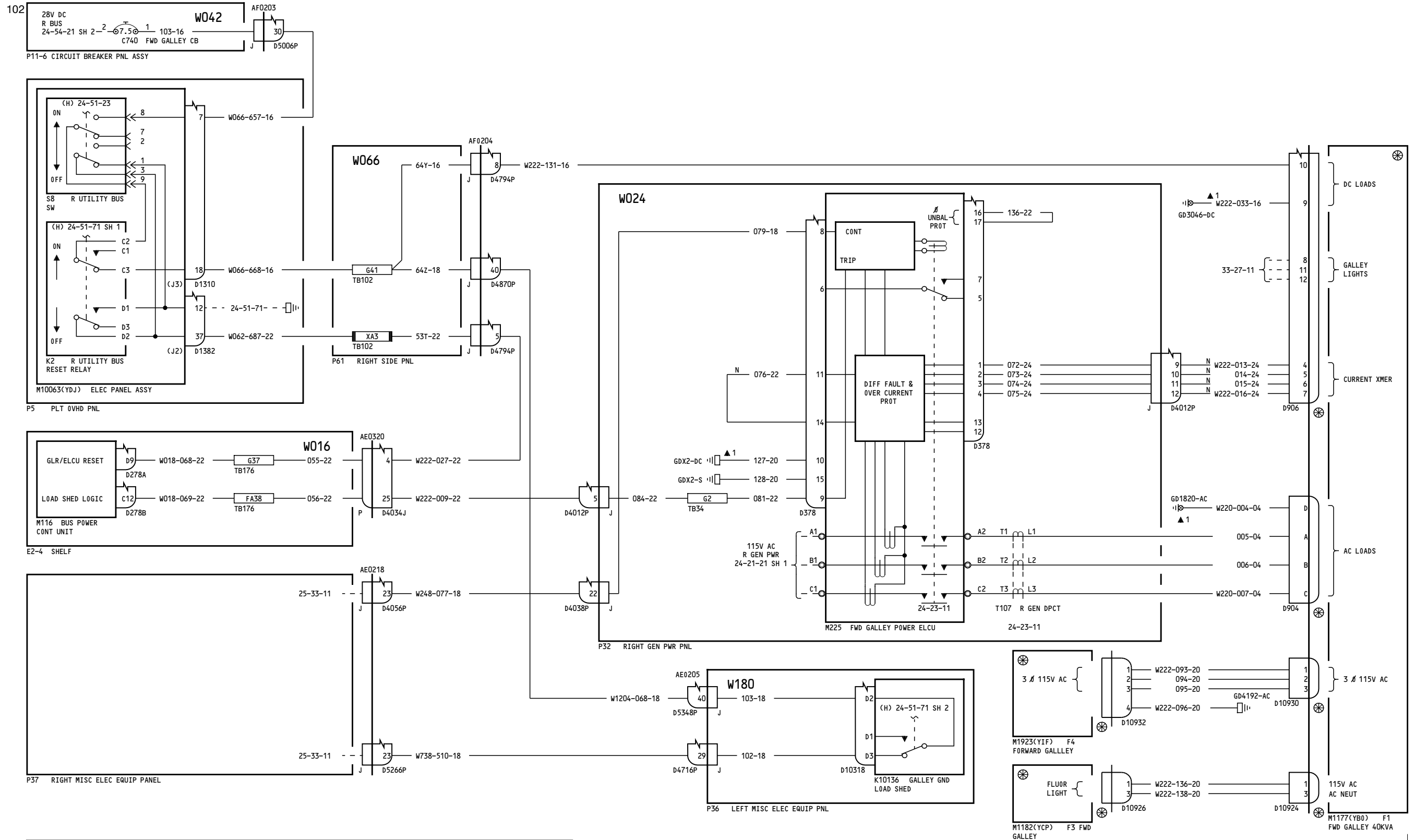

280-299

GALLEY POWER-FORWARD

D280T132

25-31-11

Page 6

Jan 21/2005

25-31-11

Page 6

Jan 21/2005

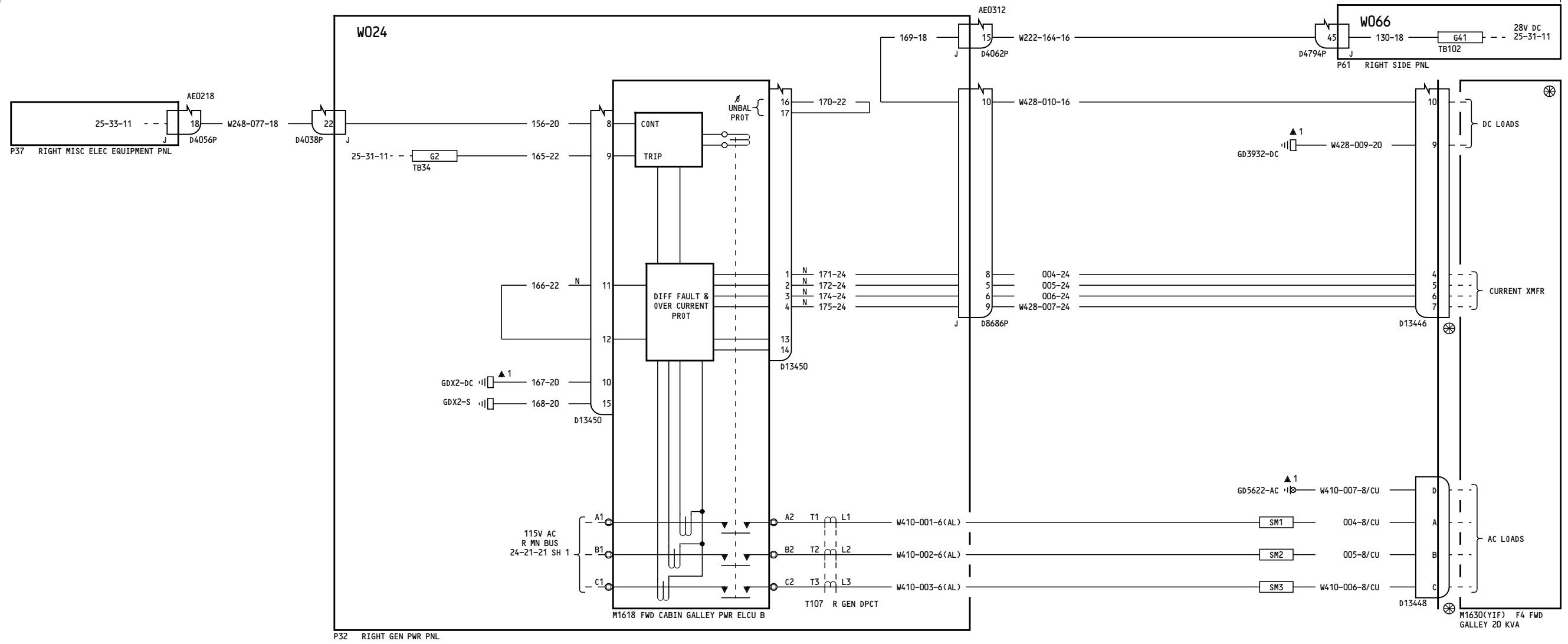

050-099

GALLEY POWER-LEFT FORWARD

25-31-12

Page 1

D280T132

Jan 21/2005

25-31-12

Page 1

Jan 21/2005

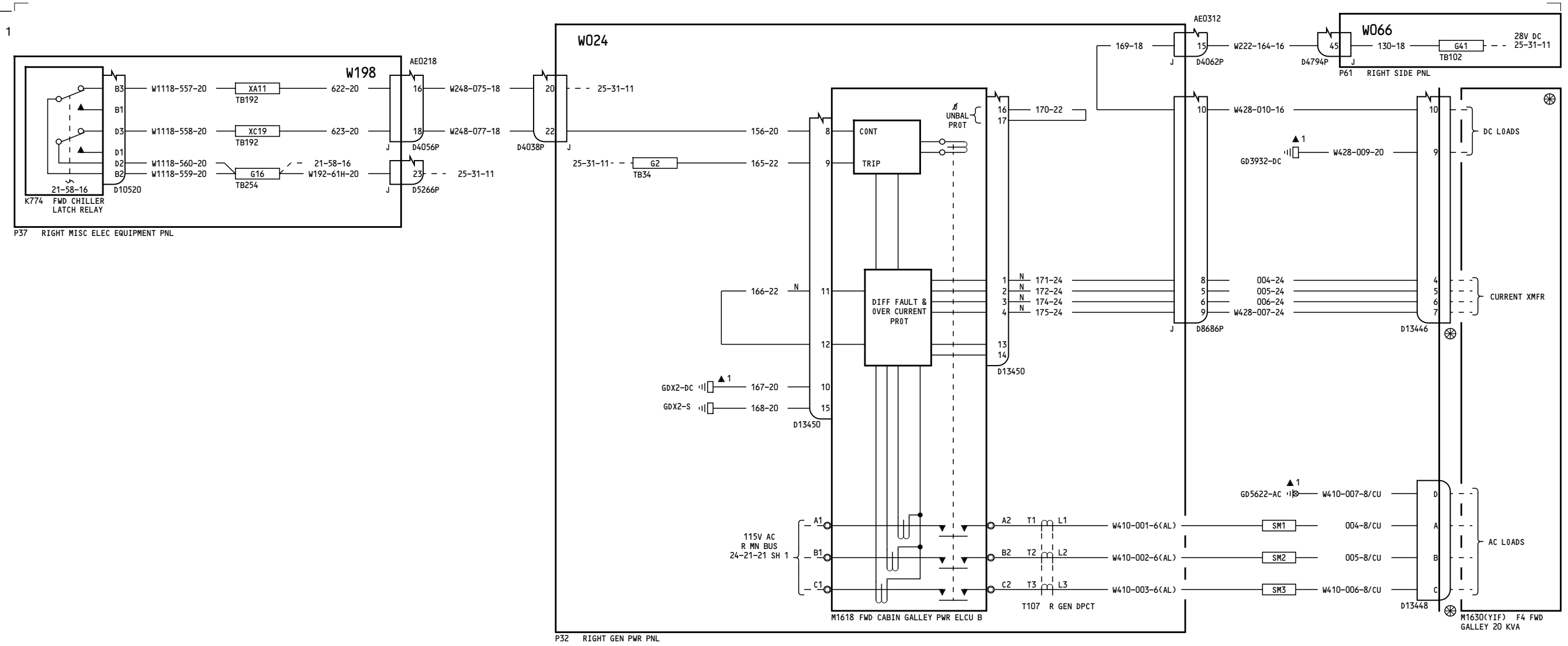

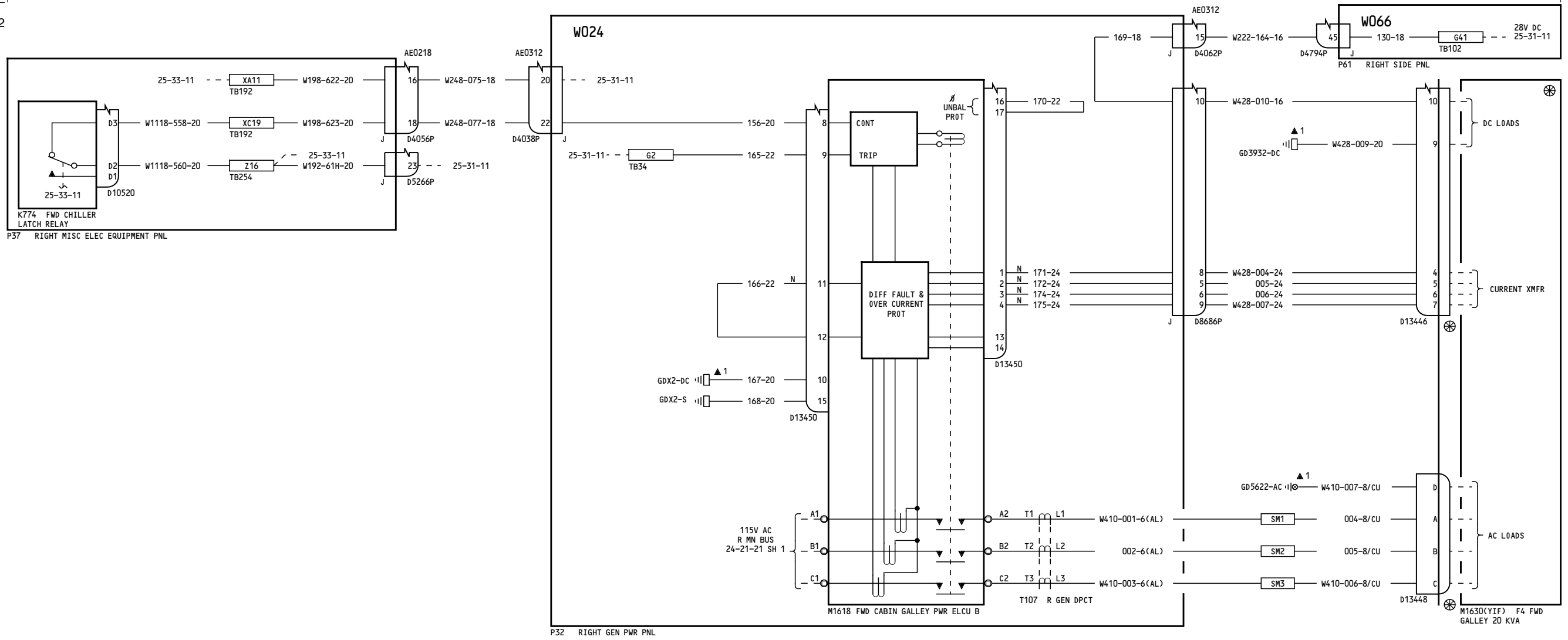

153-154	<p align="center">GALLEY POWER- LEFT FORWARD</p> <p align="center">D280T132</p>
---------	--

25-31-12

Page 3

Jan 21/2005

25-31-12

Page 3

Jan 21/2005

5

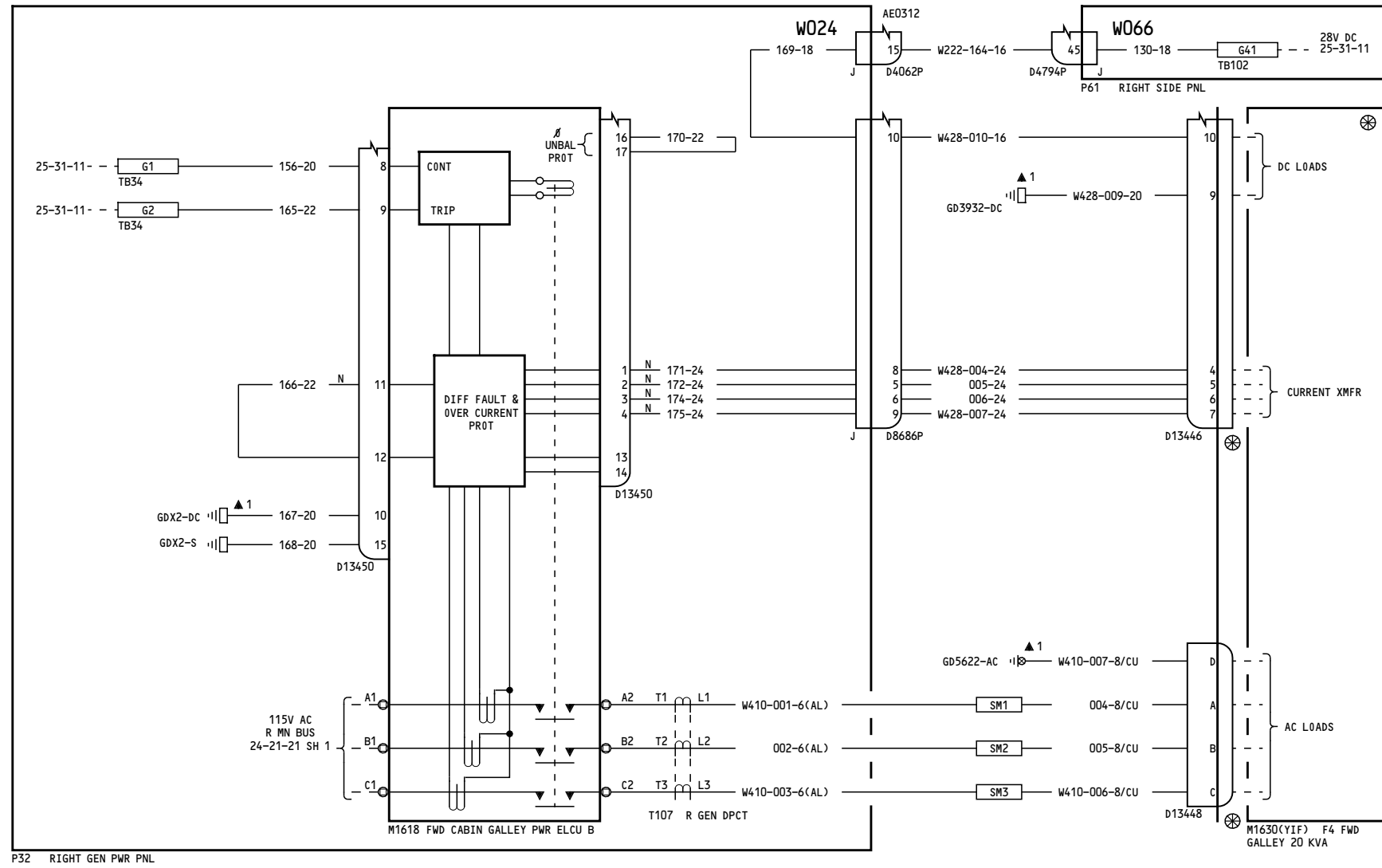

P32 RIGHT GEN PWR PNL

155-199

**GALLEY POWER-
LEFT FORWARD**

D280T132

25-31-12

Page 4

Jan 21/2005

25-31-12

Page 4

Jan 21/2005

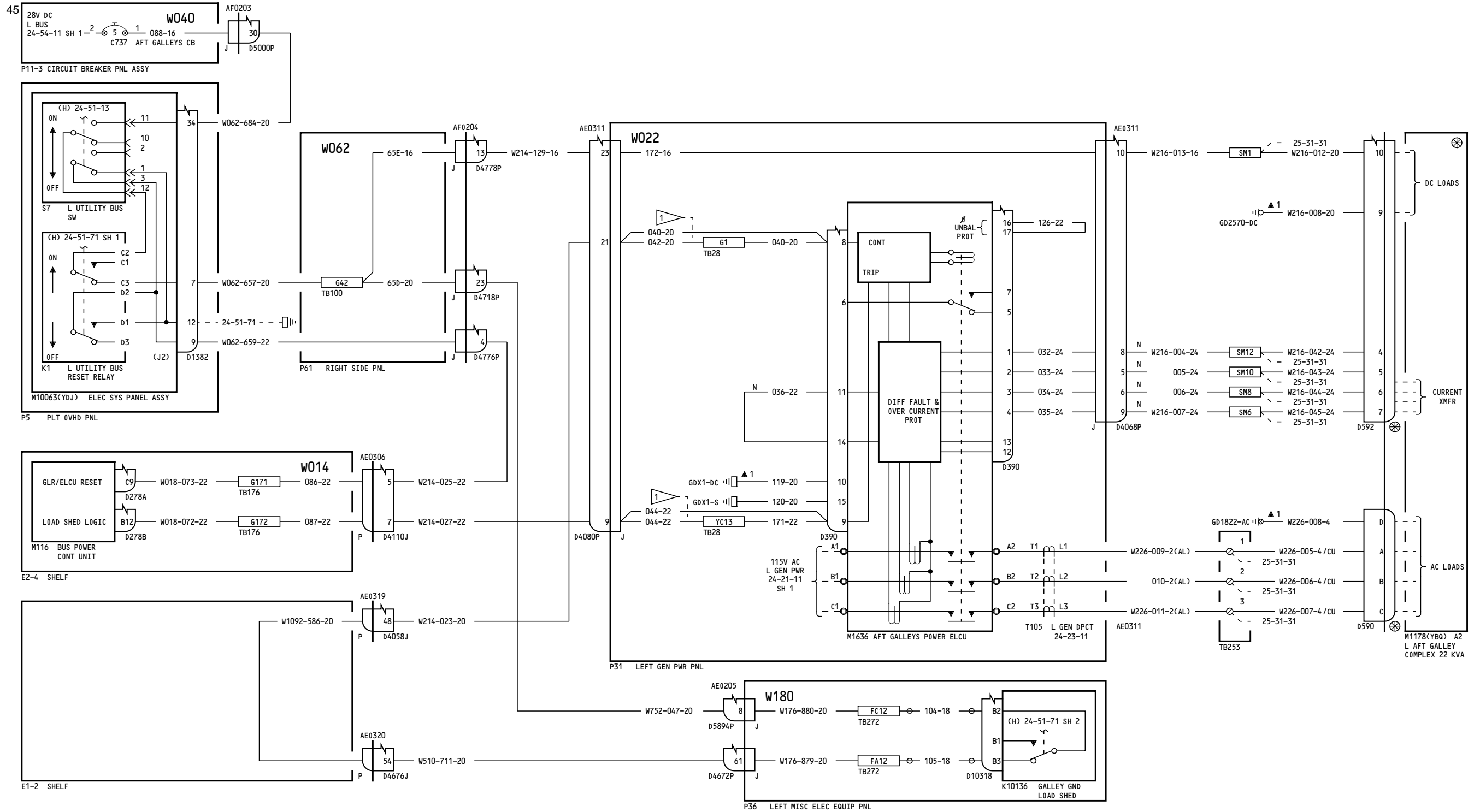

NOTES:
 1 VF071-VF090

050-099, 150-199	GALLEY POWER-LEFT AFT
	D280T132

25-31-21
 Page 1
 Jan 21/2005

25-31-21
 Page 1
 Jan 21/2005

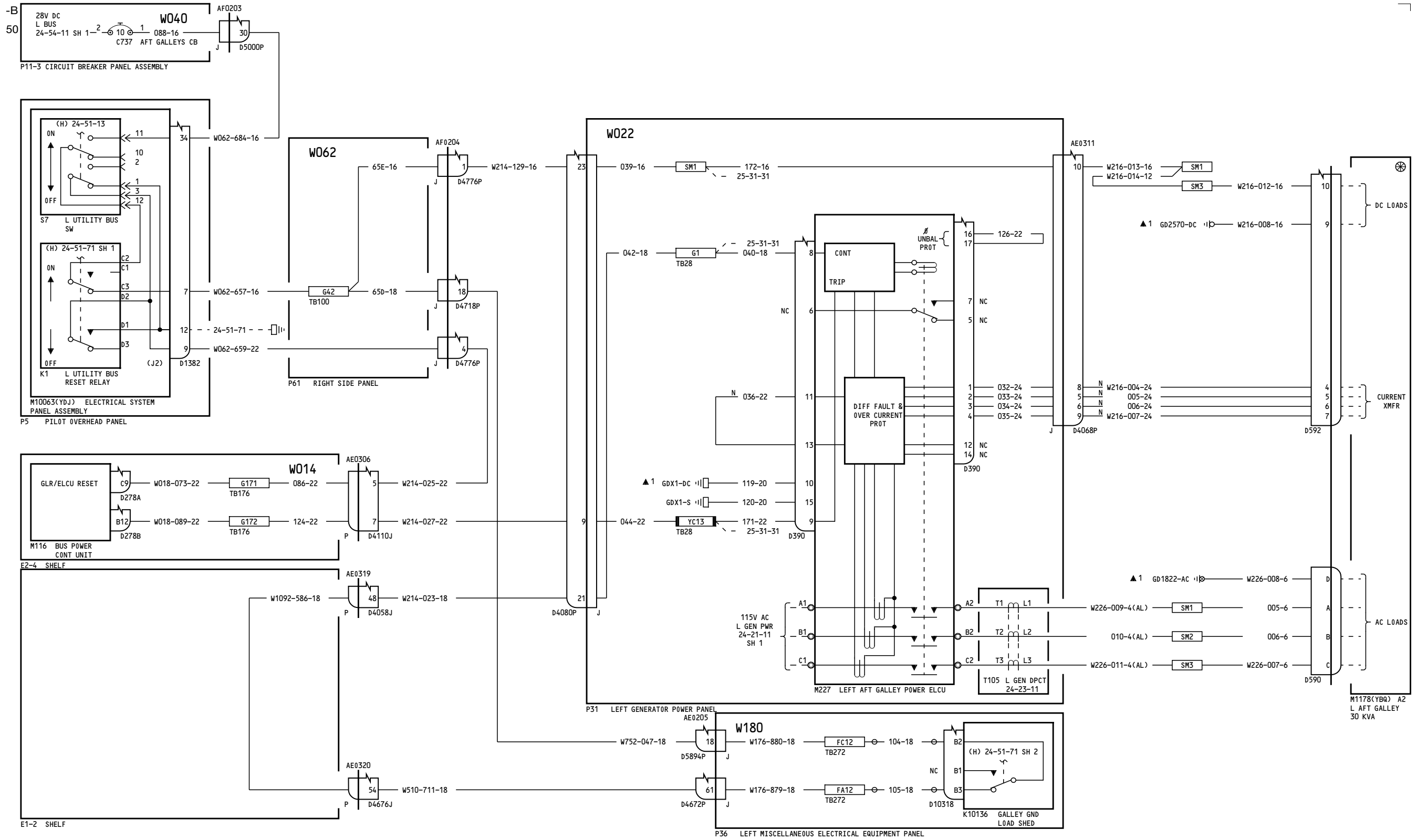

275-276

**GALLEY POWER-
LEFT AFT**

D280T132

25-31-21

Page 2
Sheet 1
Jan 21/2005

25-31-21

Page 2
Sheet 1
Jan 21/2005

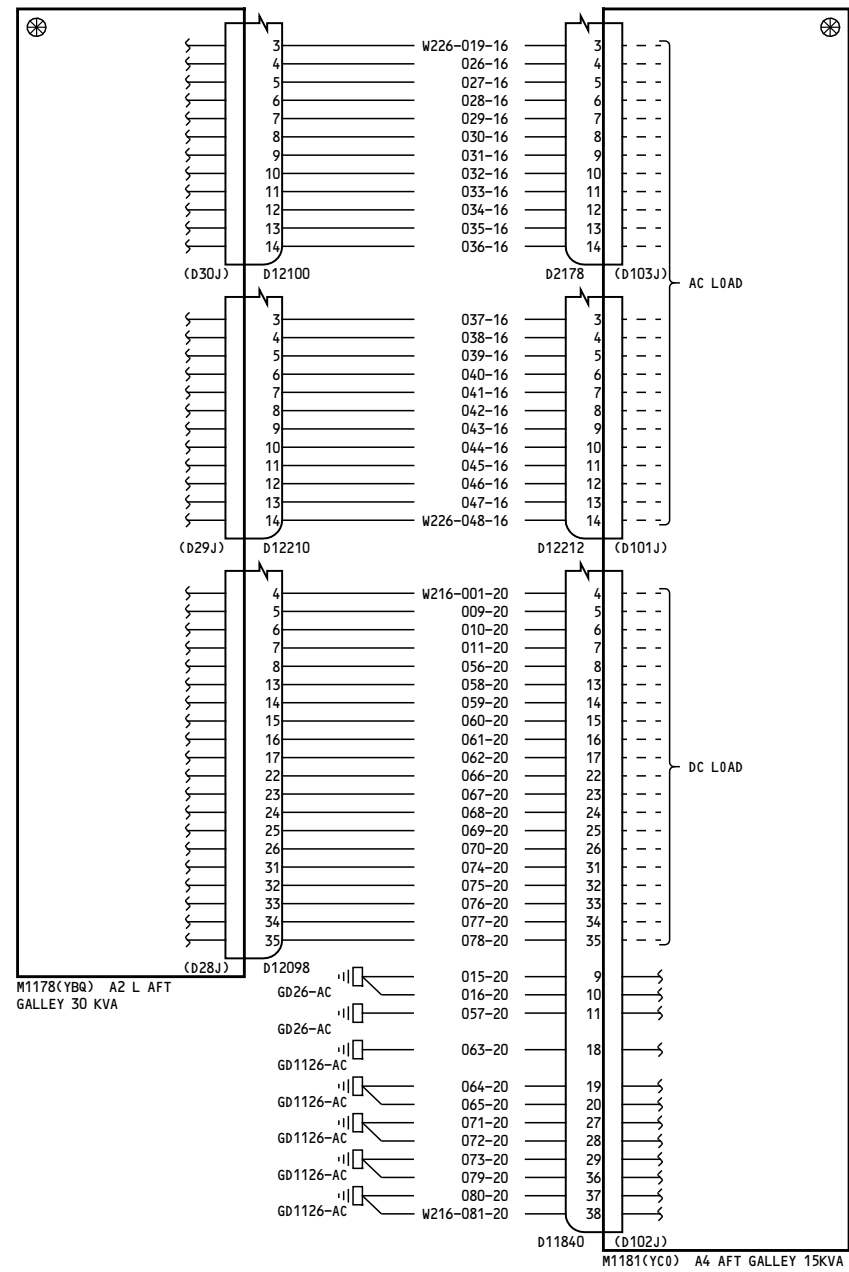

275-276

GALLEY POWER-LEFT AFT

25-31-21

Page 2
Sheet 2
Jan 21/2005

D280T132

25-31-21

Page 2
Sheet 2
Jan 21/2005

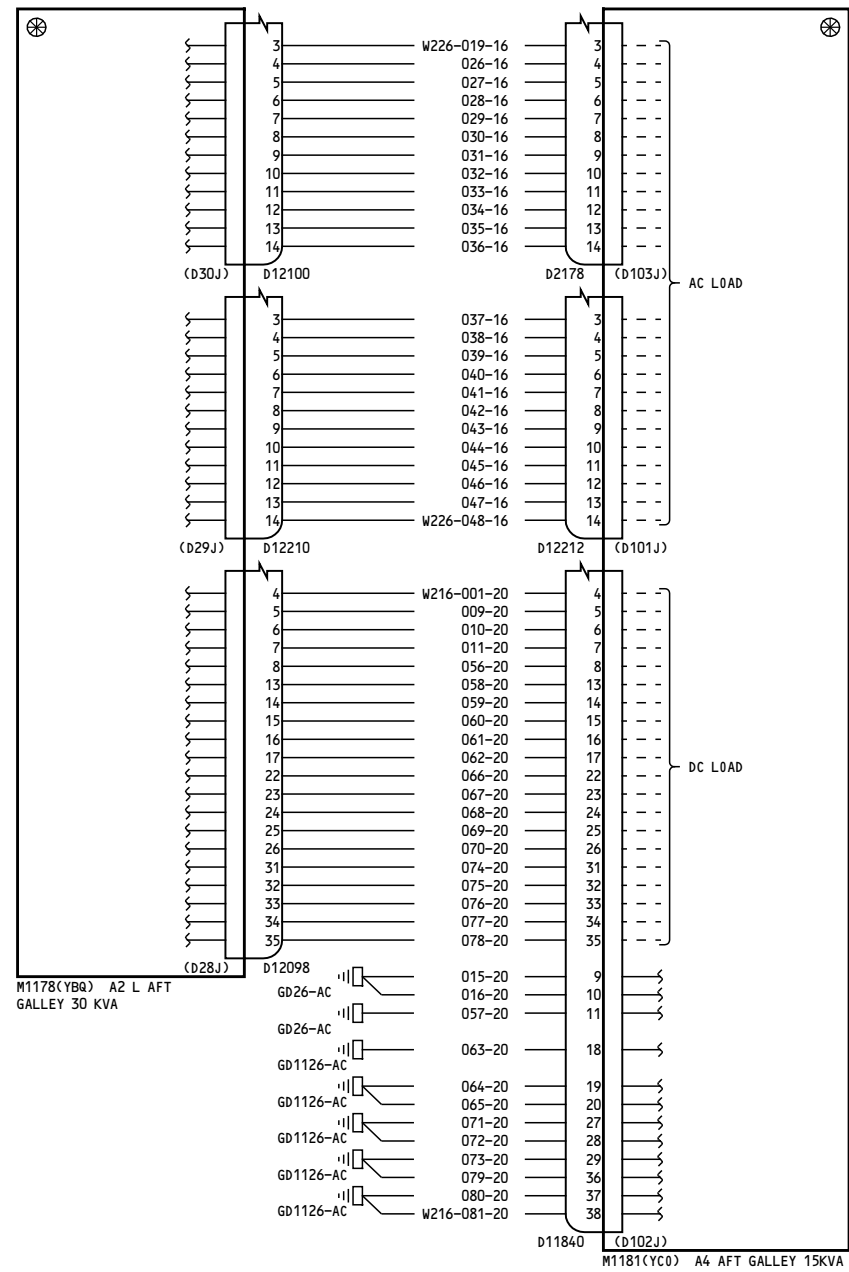

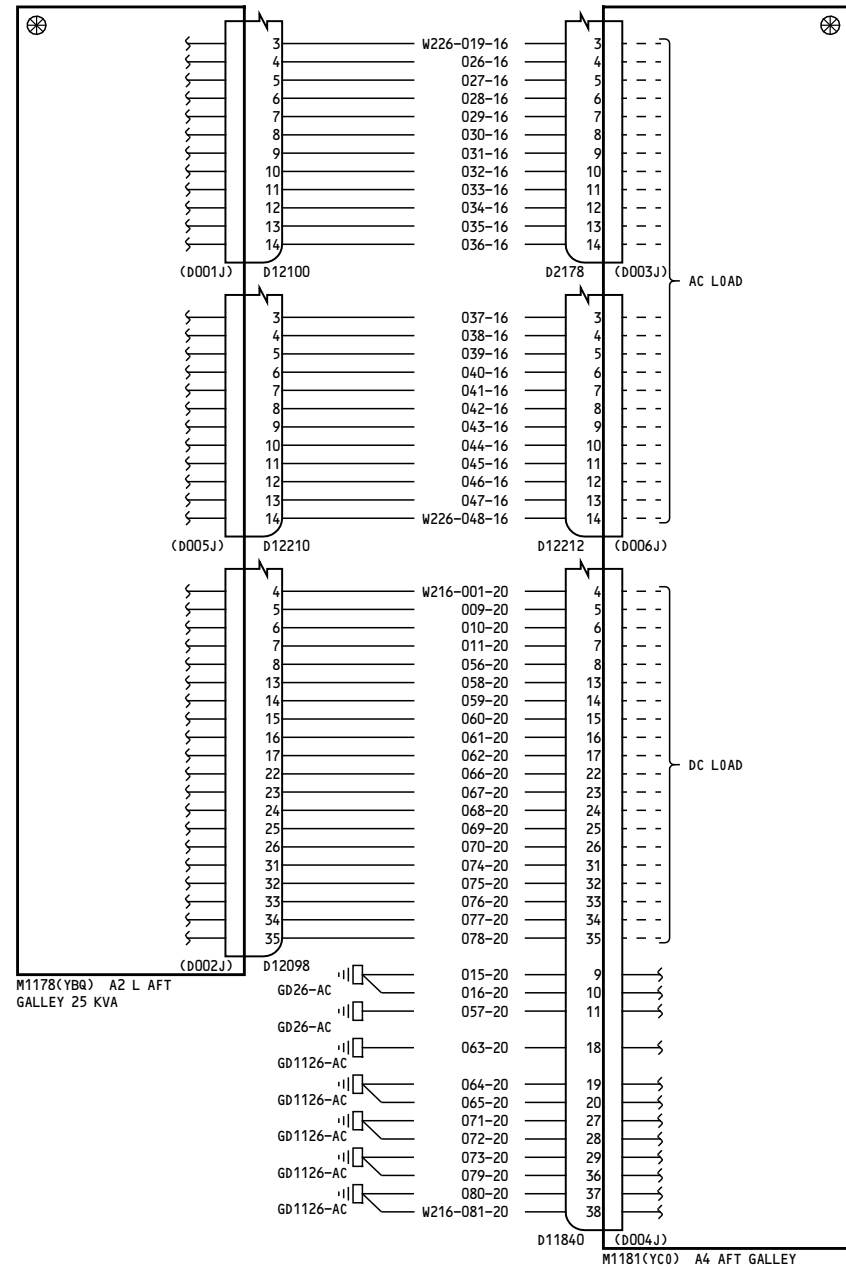

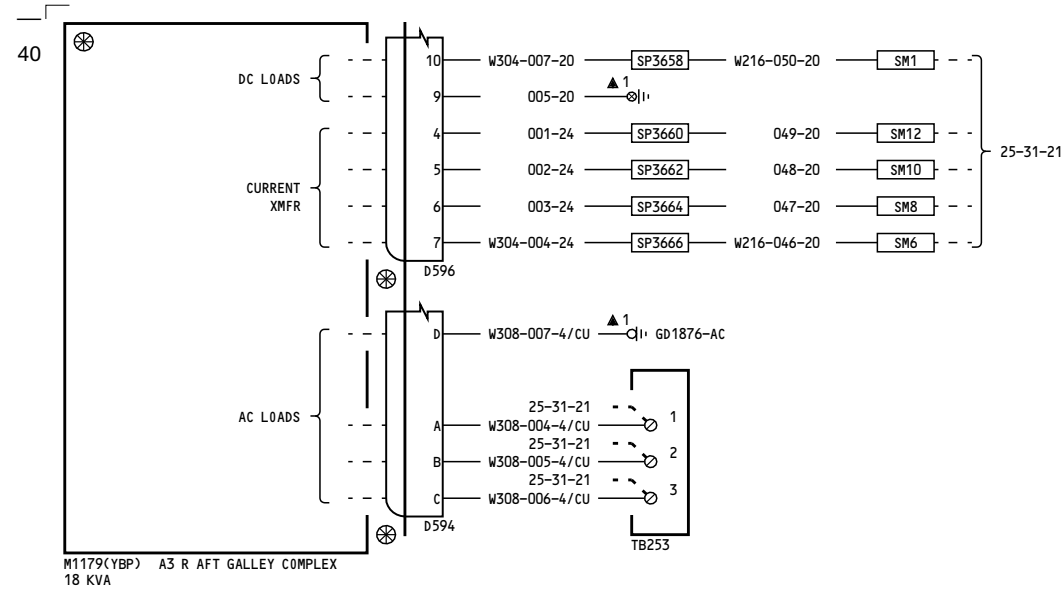

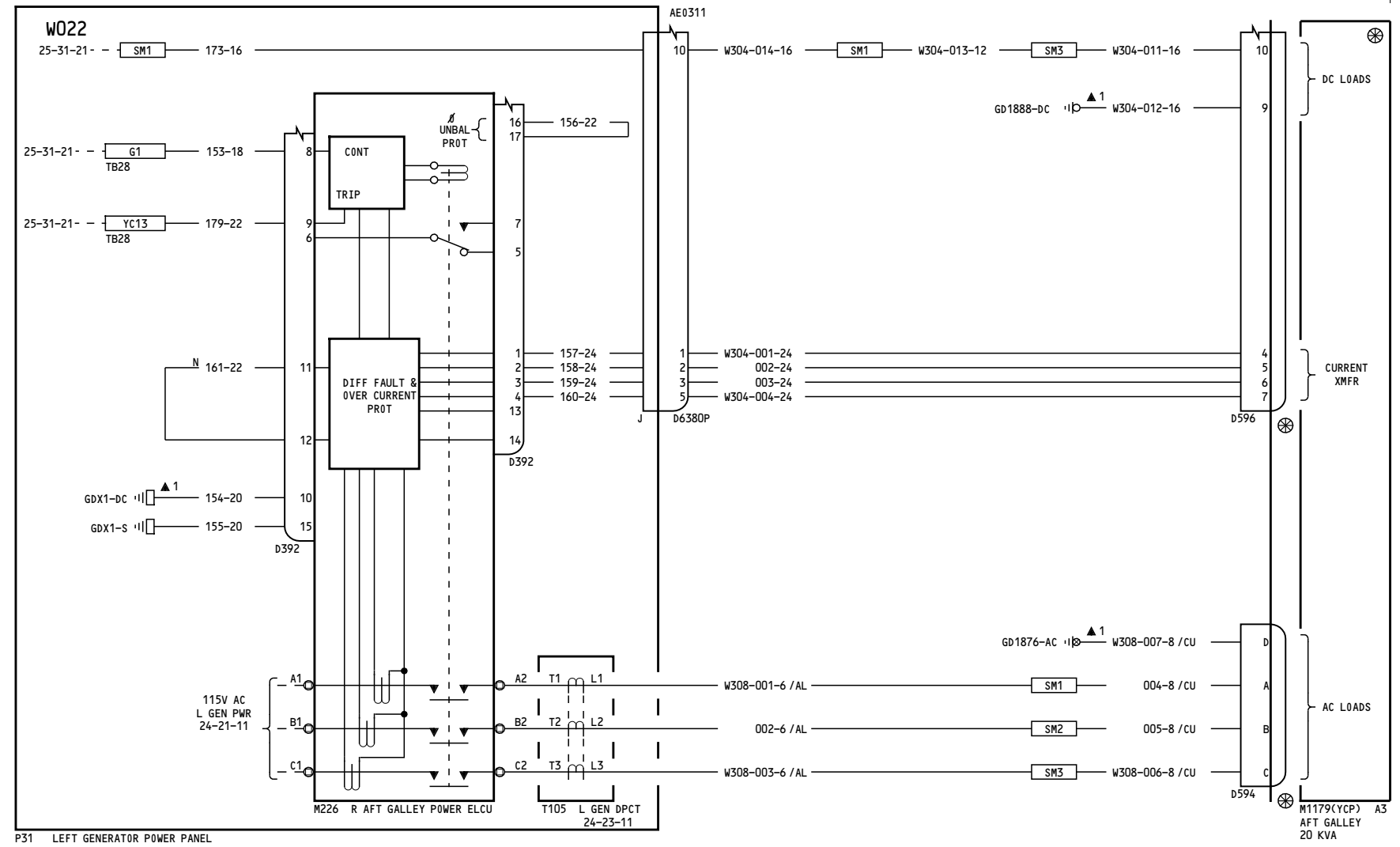

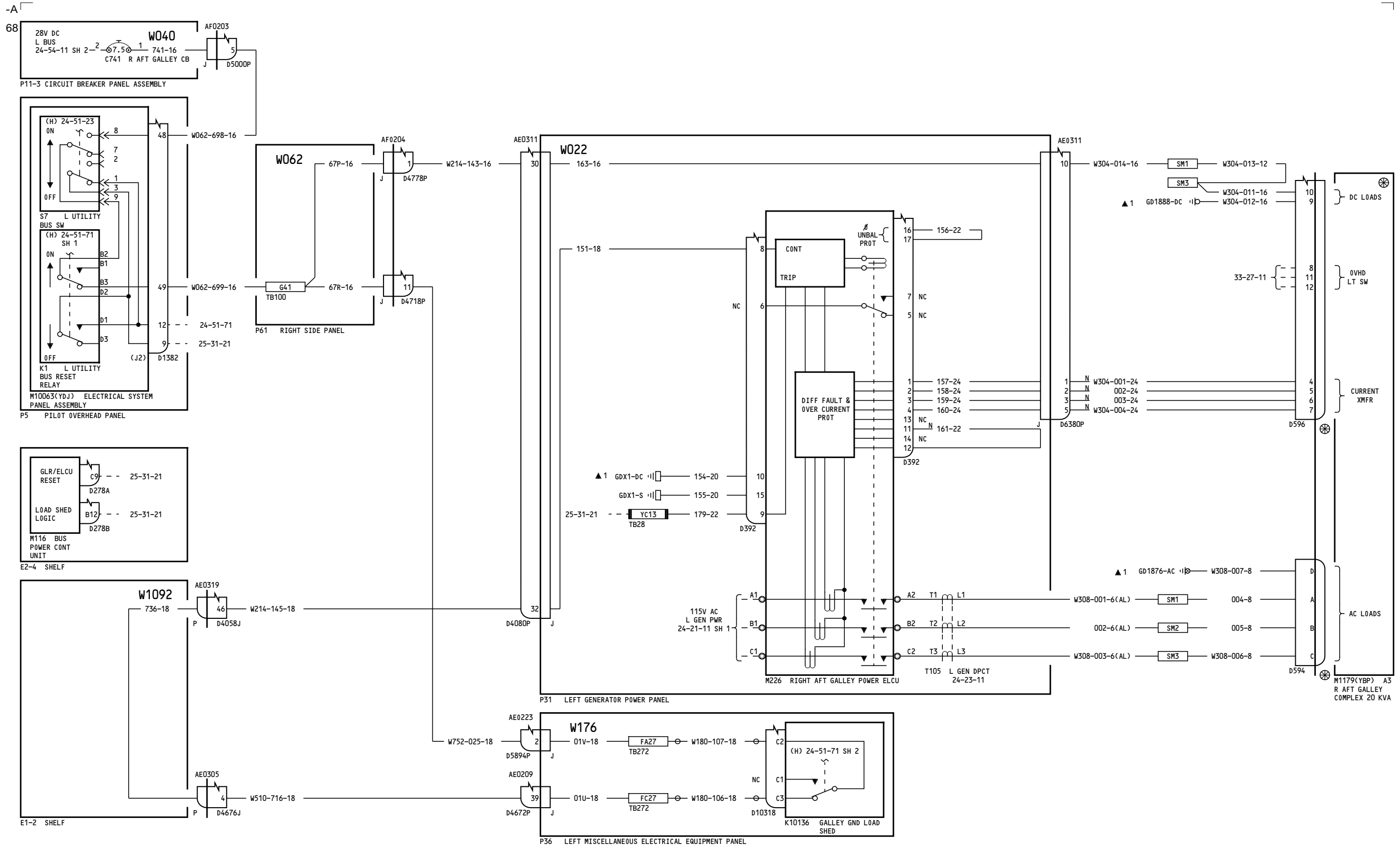

277-278

GALLEY POWER-
RIGHT AFT

25-31-31

Page 3

Jan 21/2005

D280T132

25-31-31

Page 3

Jan 21/2005

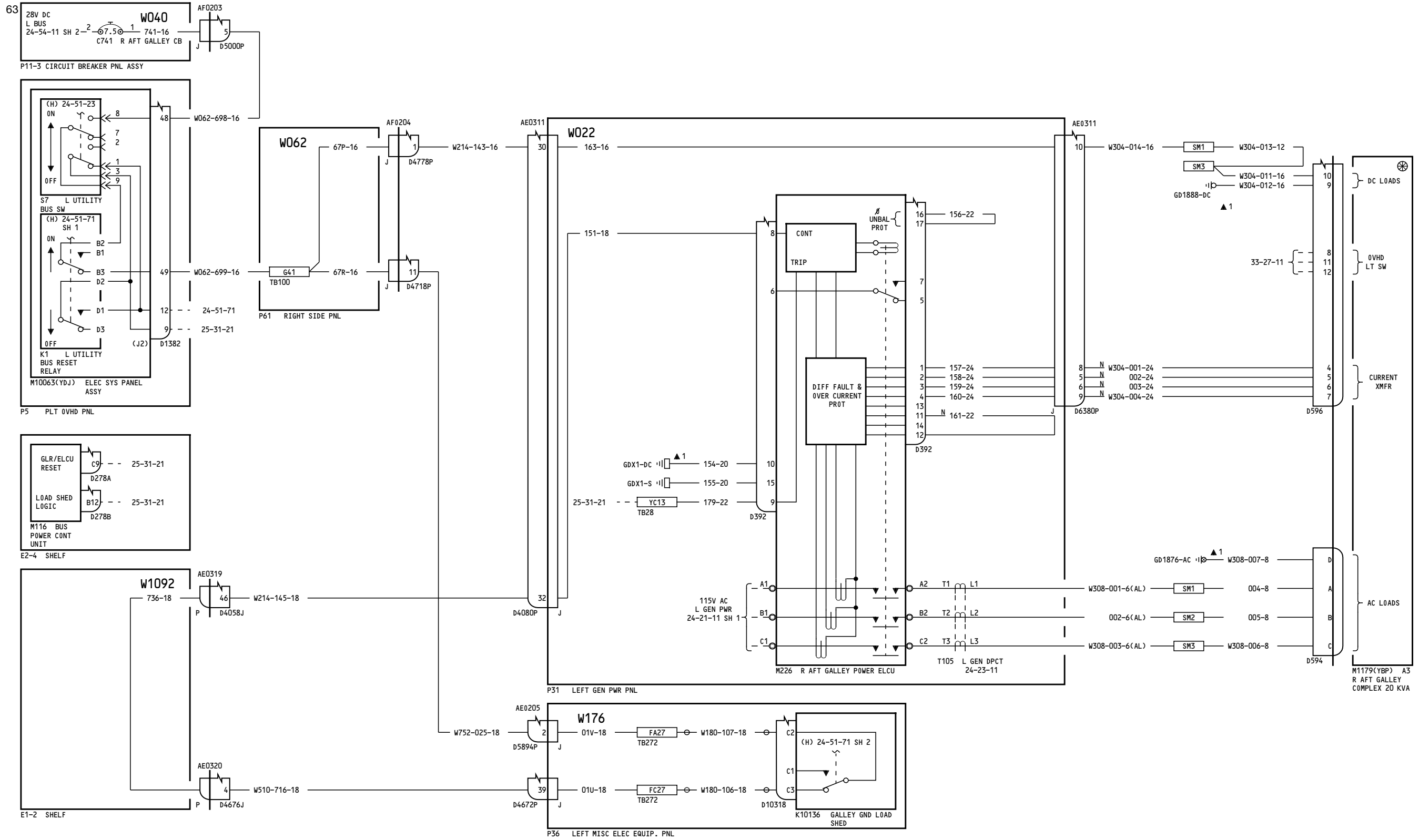

280-299

**GALLEY POWER-
RIGHT AFT**

25-31-31

Page 4

D280T132

25-31-31

Page 4

Jan 21/2005

BOEING PROPRIETARY - Copyright © - Unpublished Work - See title page for details.

25-31-31

Page 4

Jan 21/2005

178

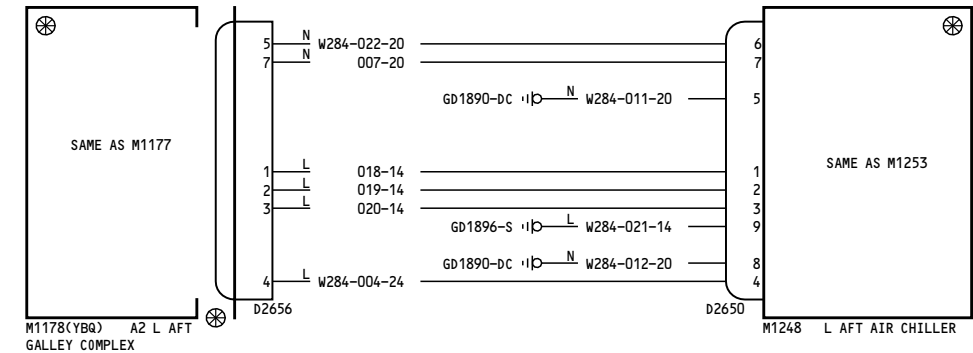
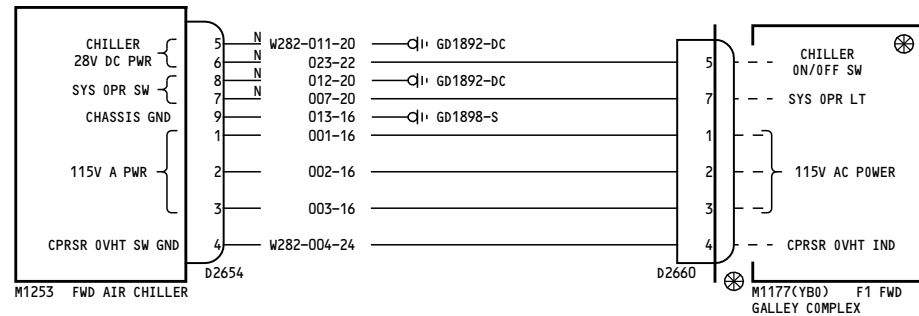
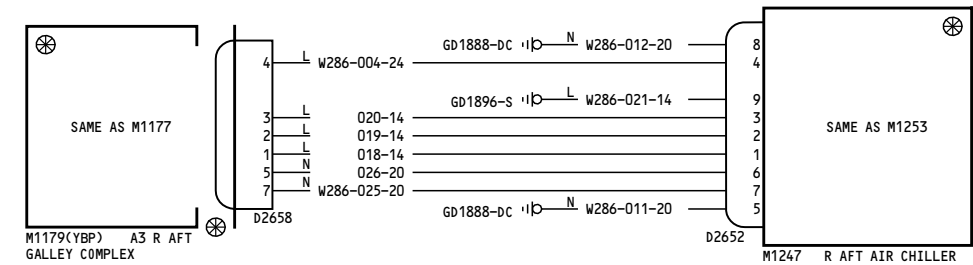
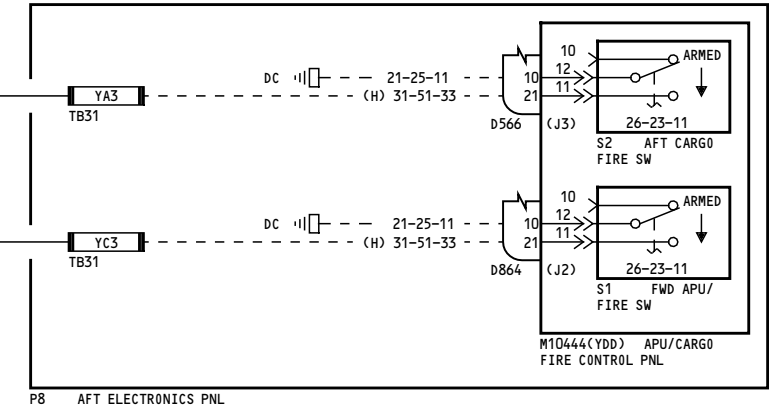
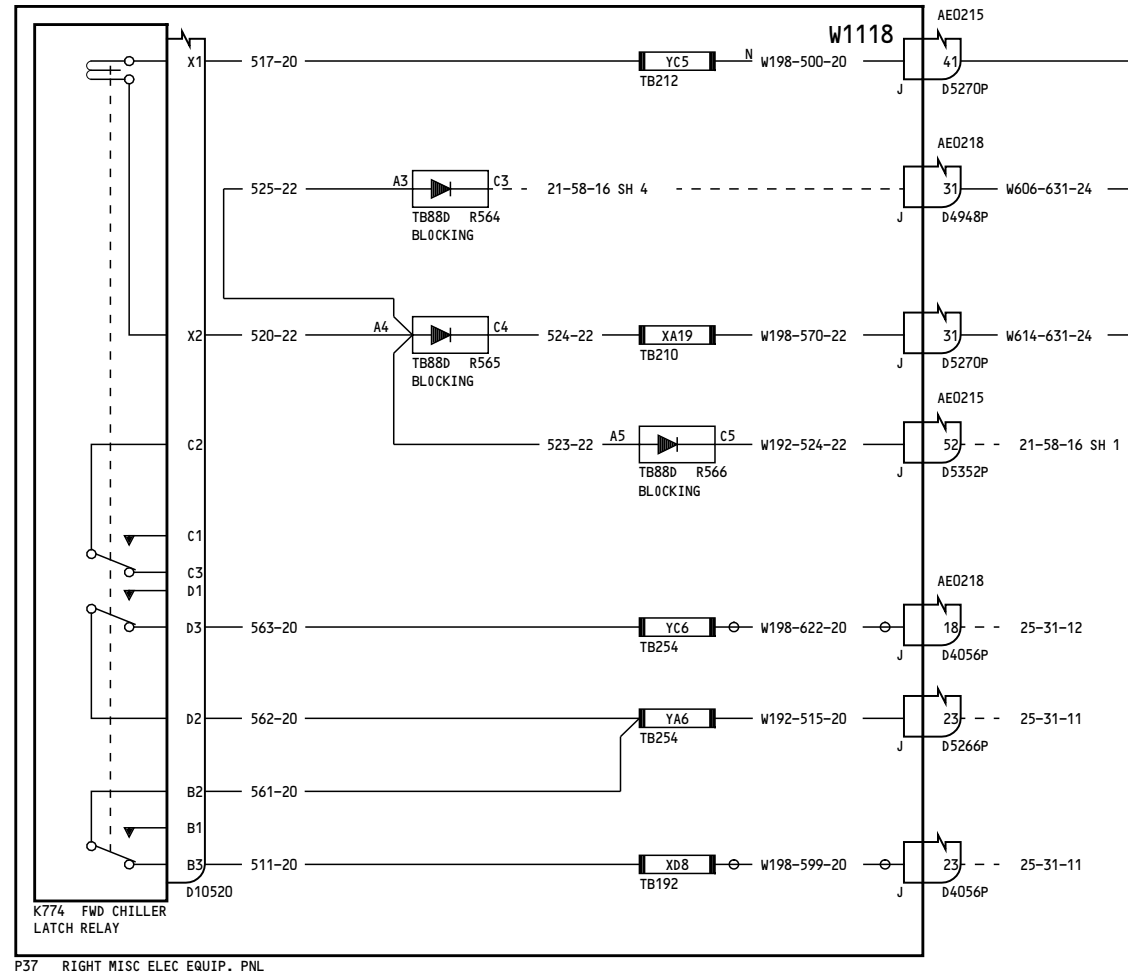
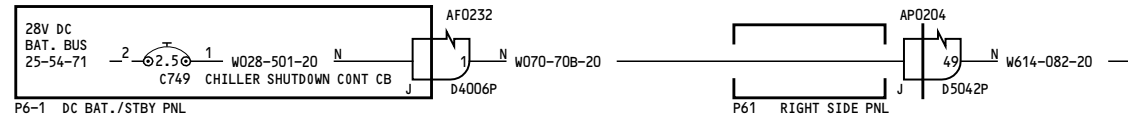

050-051

REFRIGERATION POWER

25-33-11

Page 1.1

Jan 21/2005

D280T132

Incorporates 25-0180 R03

25-33-11

Page 1.1

Jan 21/2005

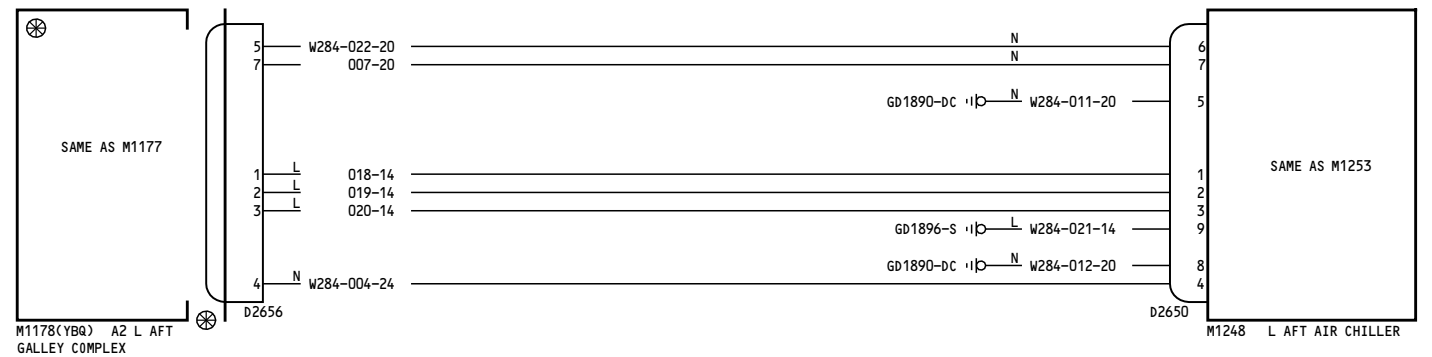
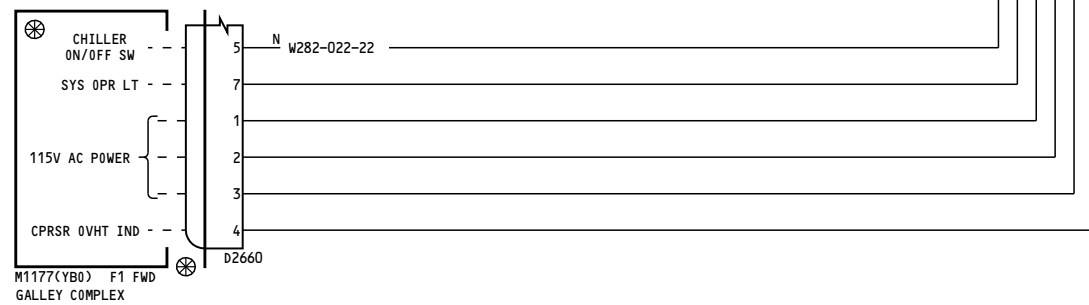
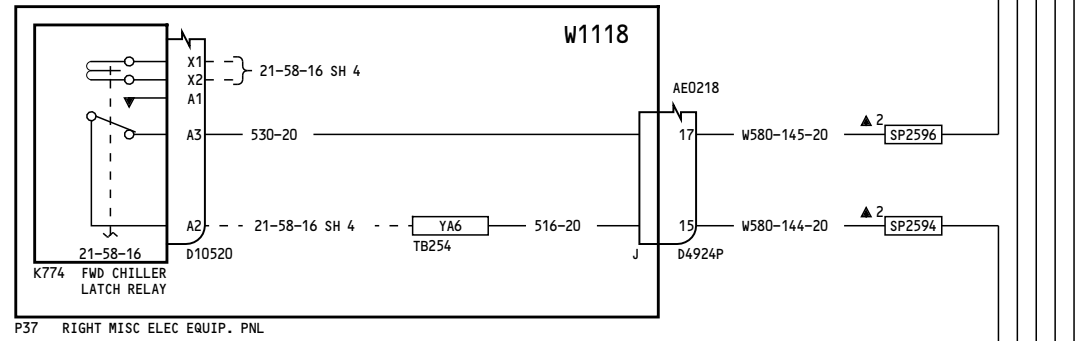
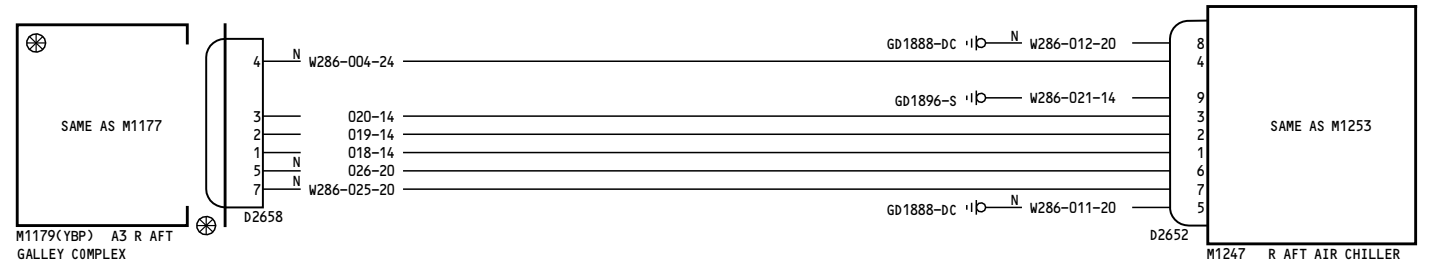
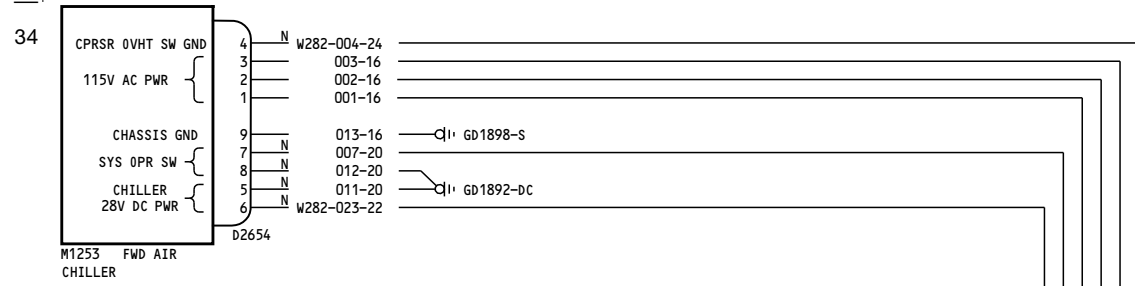

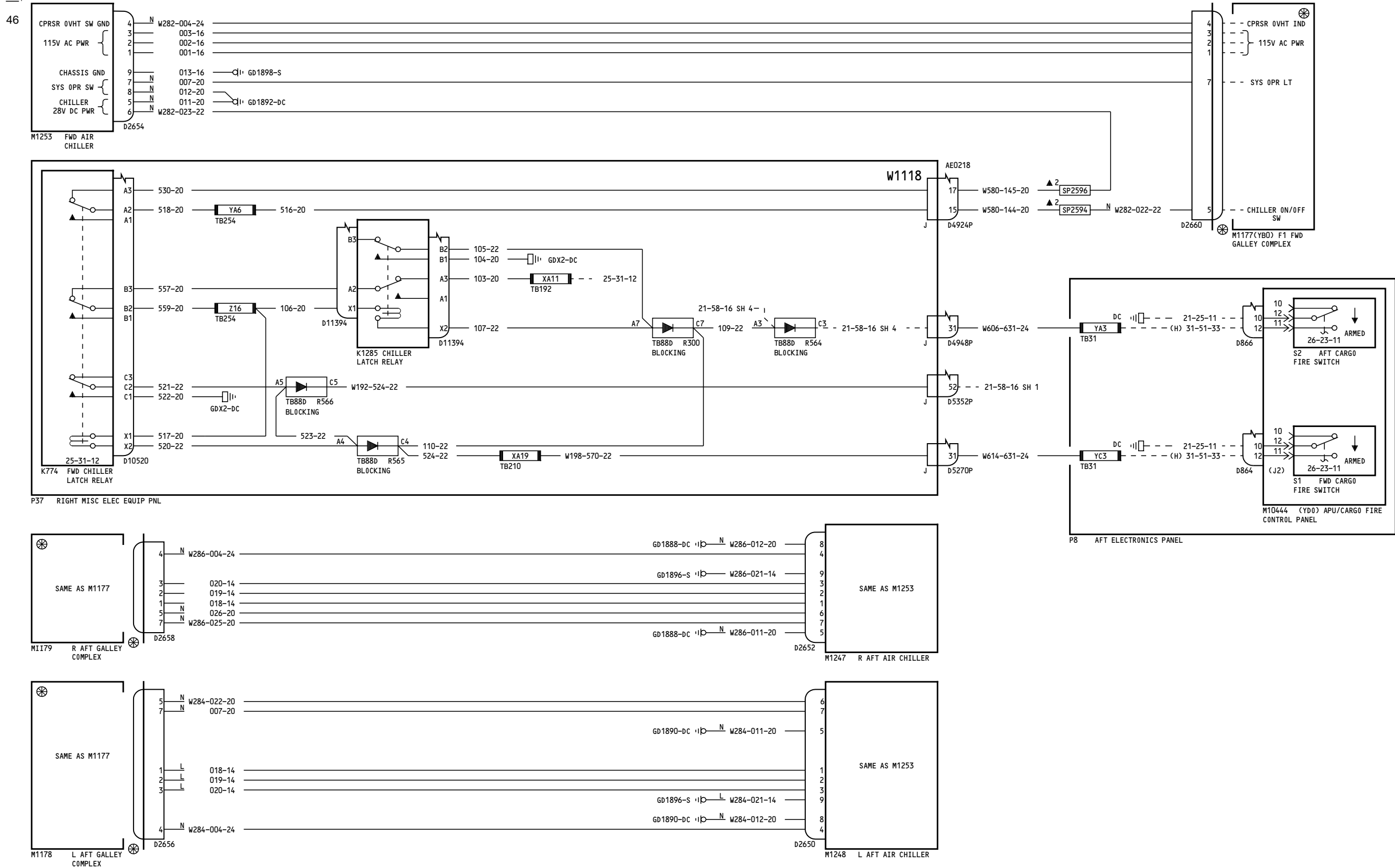

153-154

REFRIGERATION POWER

25-33-11

Page 3

Jan 21/2005

D280T132

25-33-11

Page 3

Jan 21/2005

172

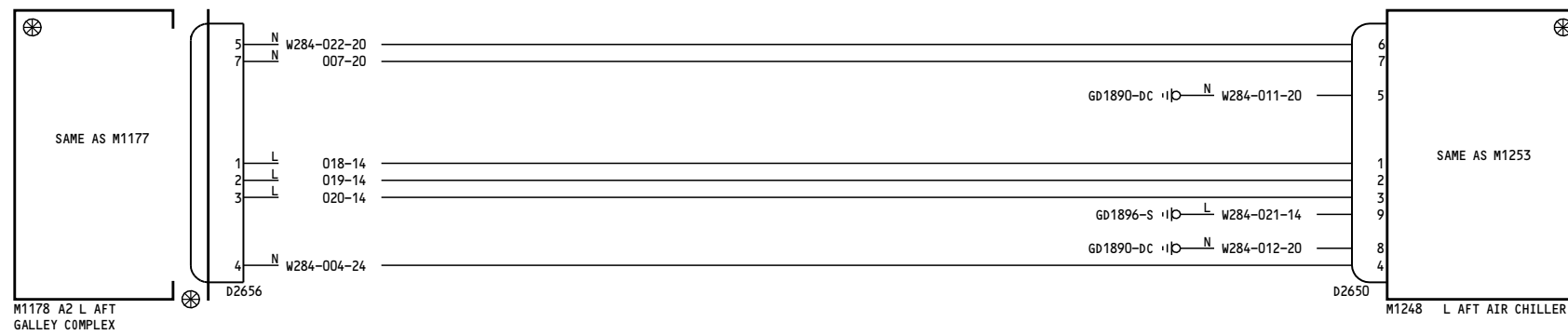
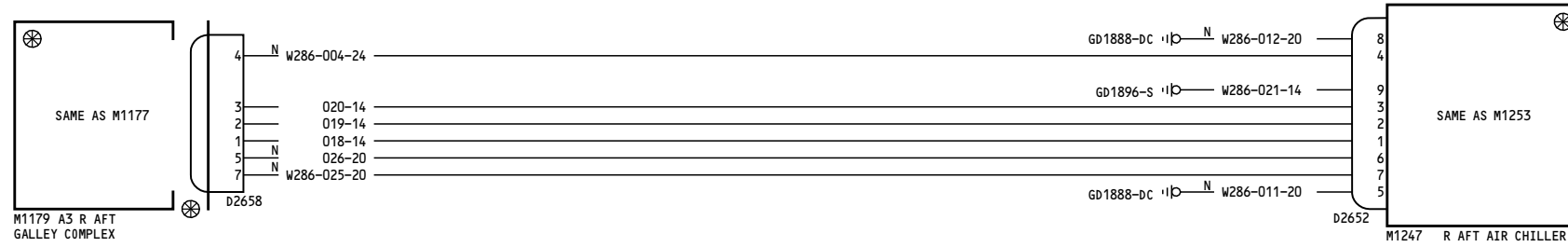
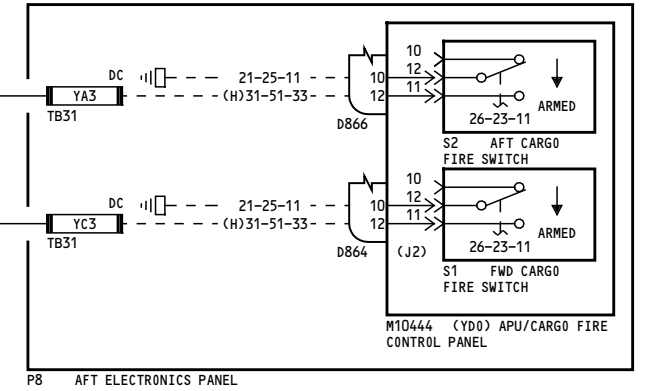
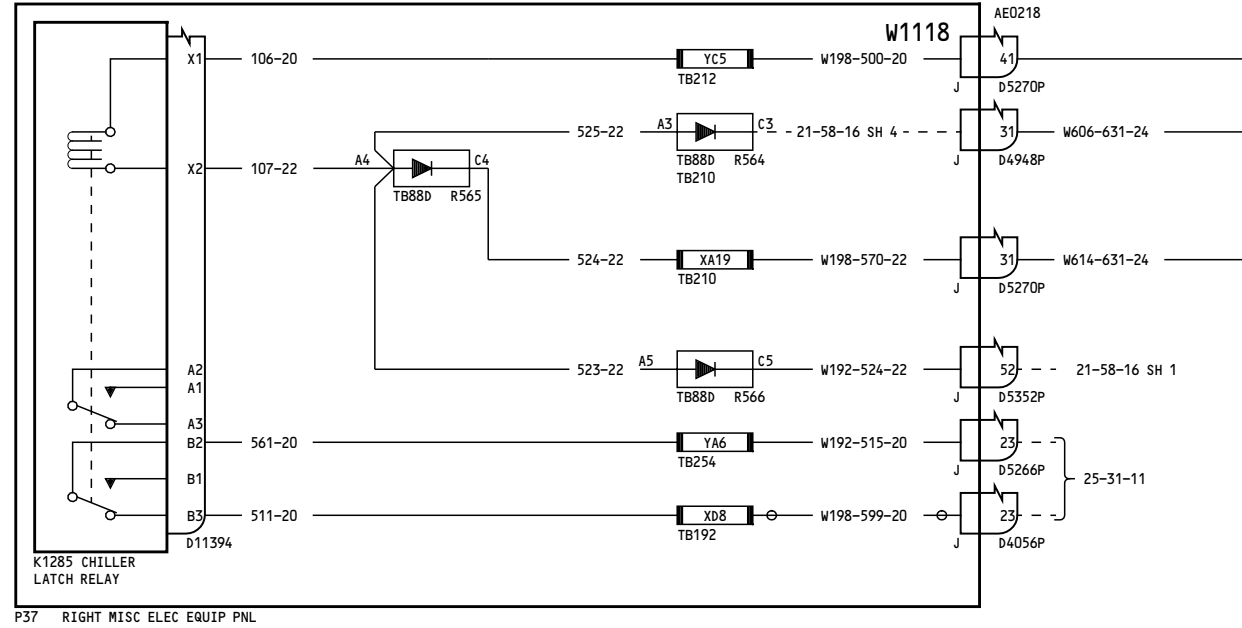
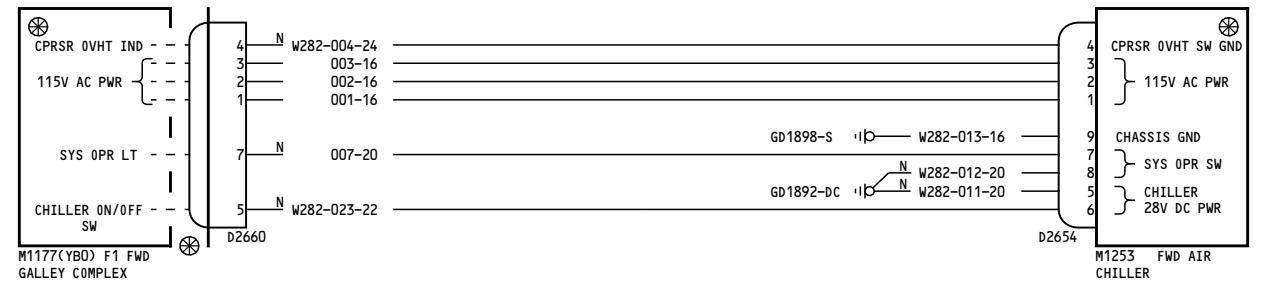
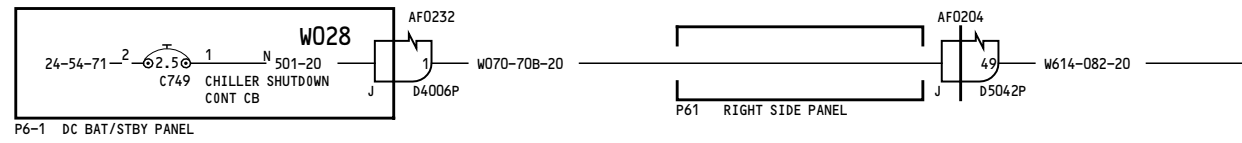

155-157, 165-166

REFRIGERATION POWER

25-33-11

Incorporates
25-0180 R03

Page 4.1

25-33-11

Page 4.1

D280T132

Jan 21/2005

Jan 21/2005

164

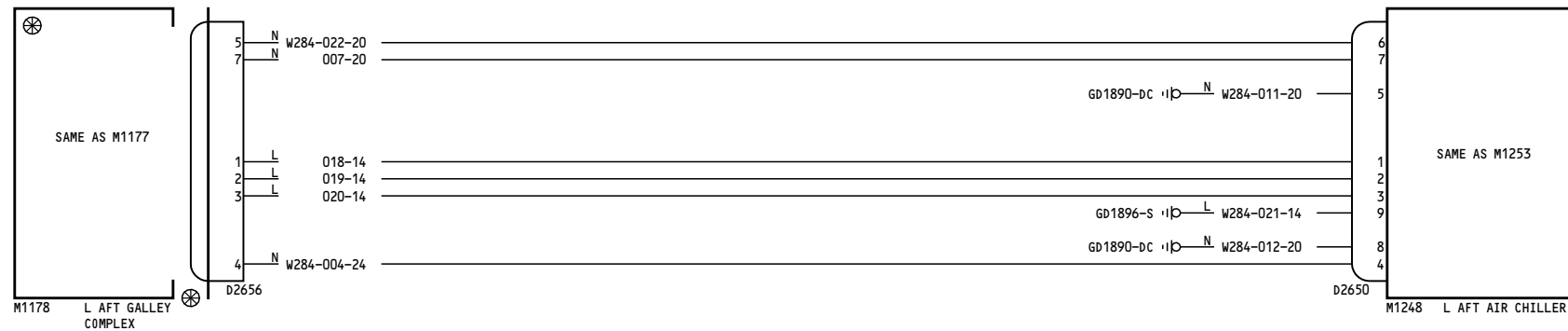
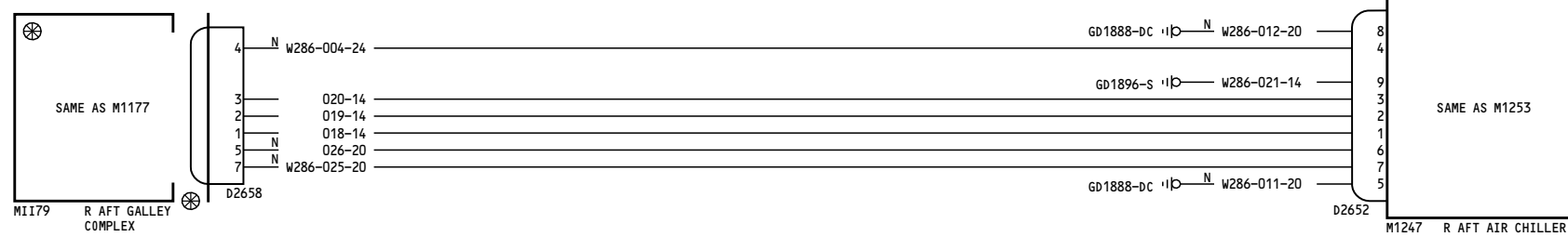
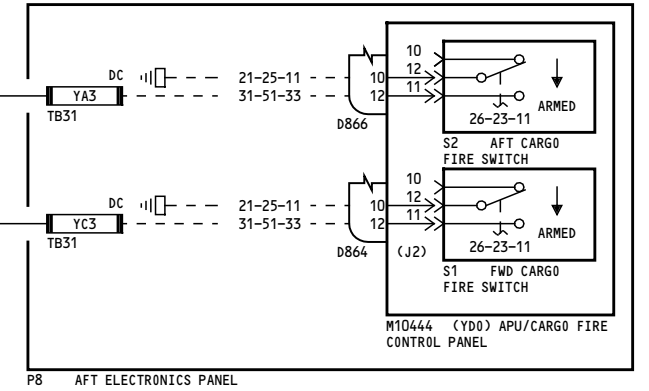
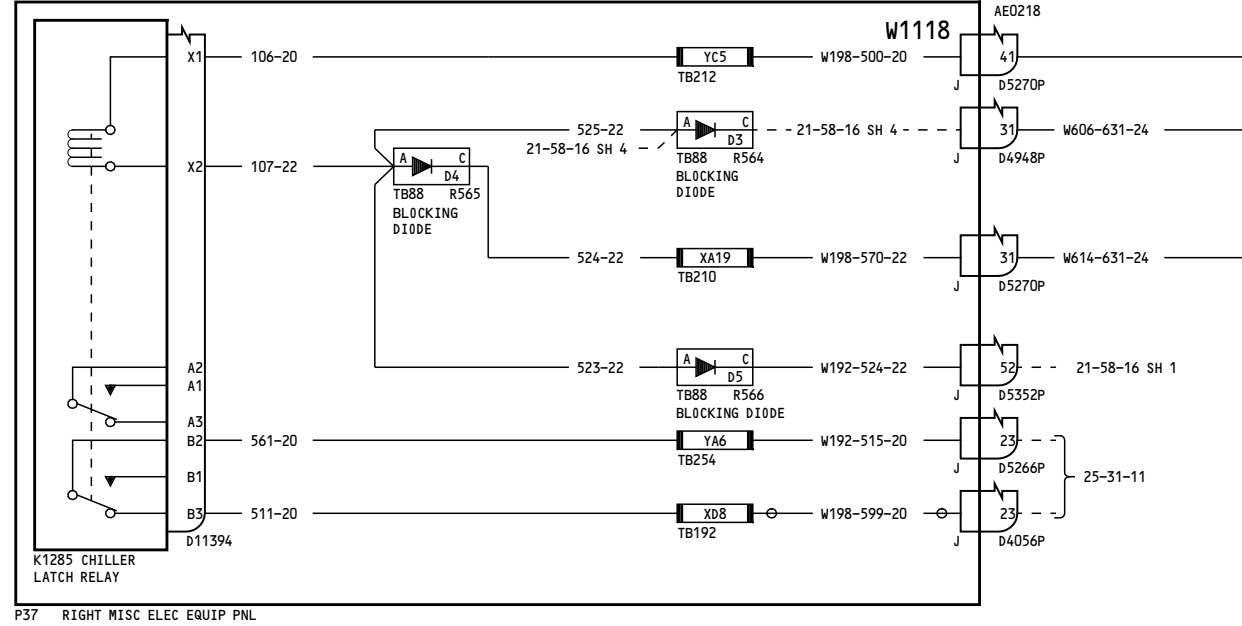
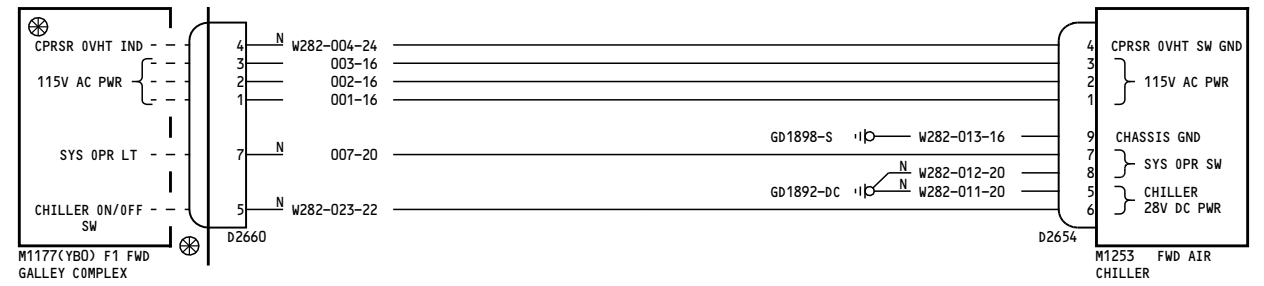
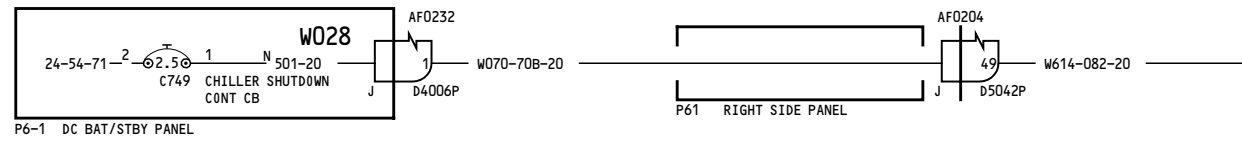

162-164

REFRIGERATION POWER

D280T132

25-33-11

Page 5.1

Jan 21/2005

Incorporates 25-0180 R03

25-33-11

Page 5.1

Jan 21/2005

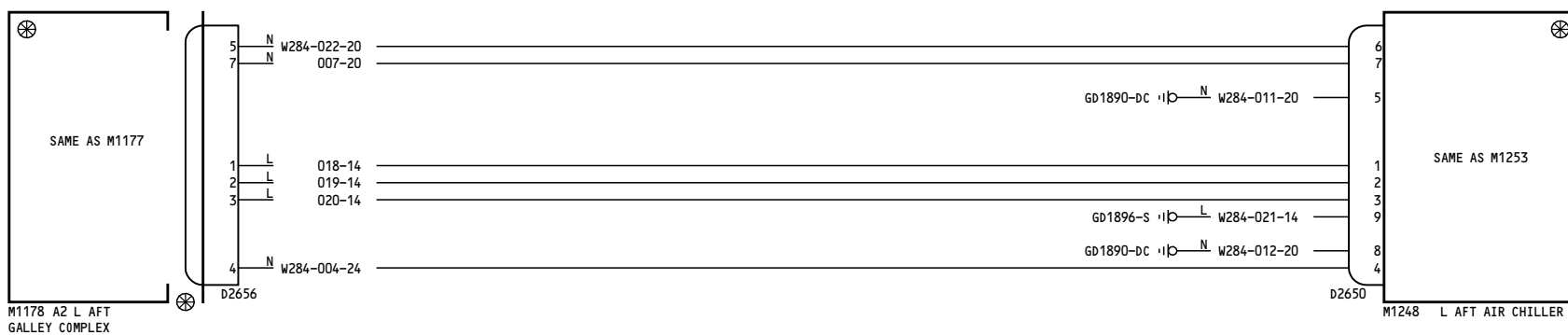
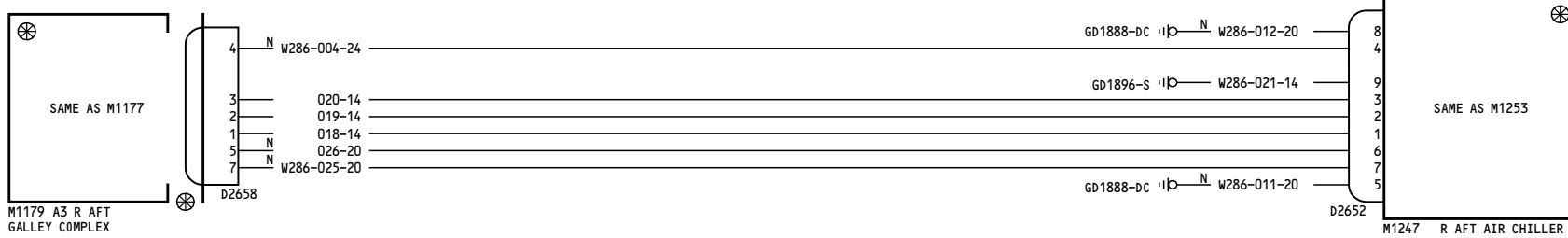
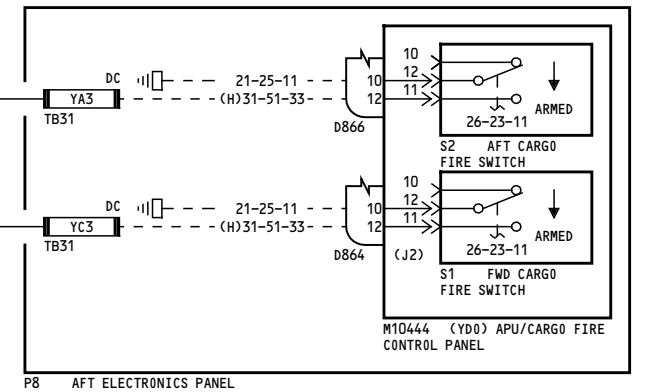
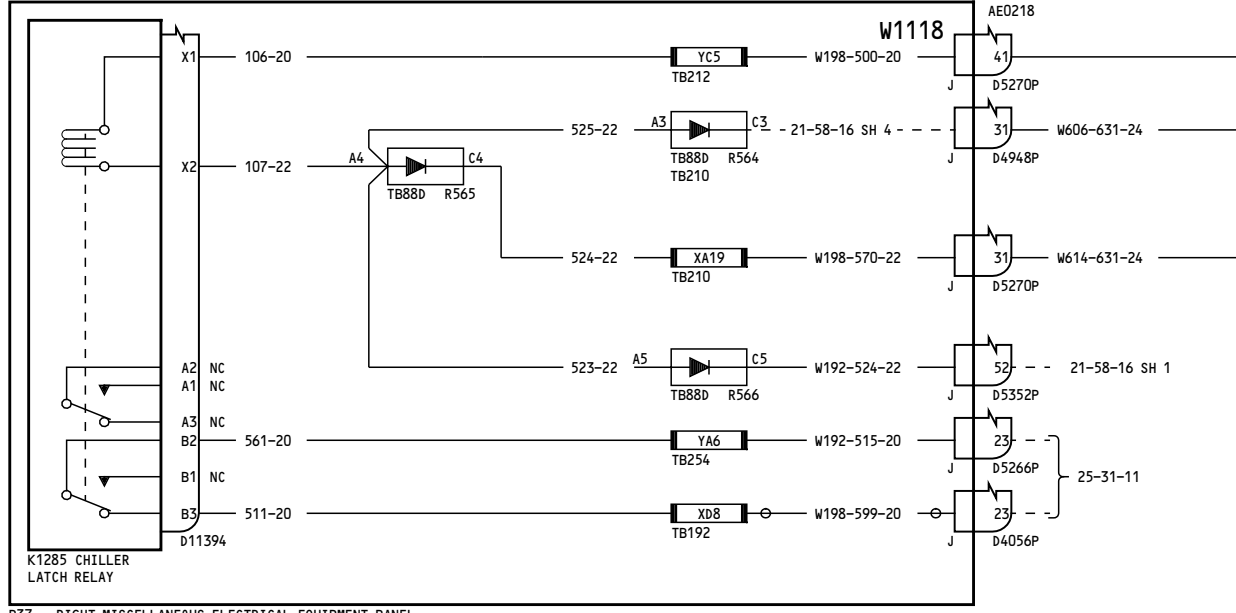
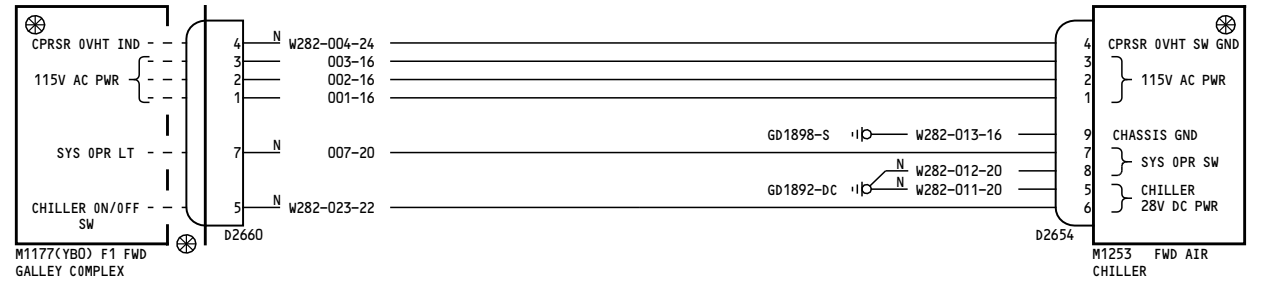
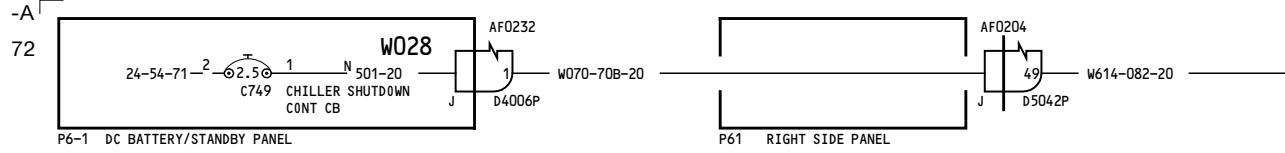

167-199

REFRIGERATION POWER

D280T132

25-33-11

Page 6

Jan 21/2005

25-33-11

Page 6

Jan 21/2005

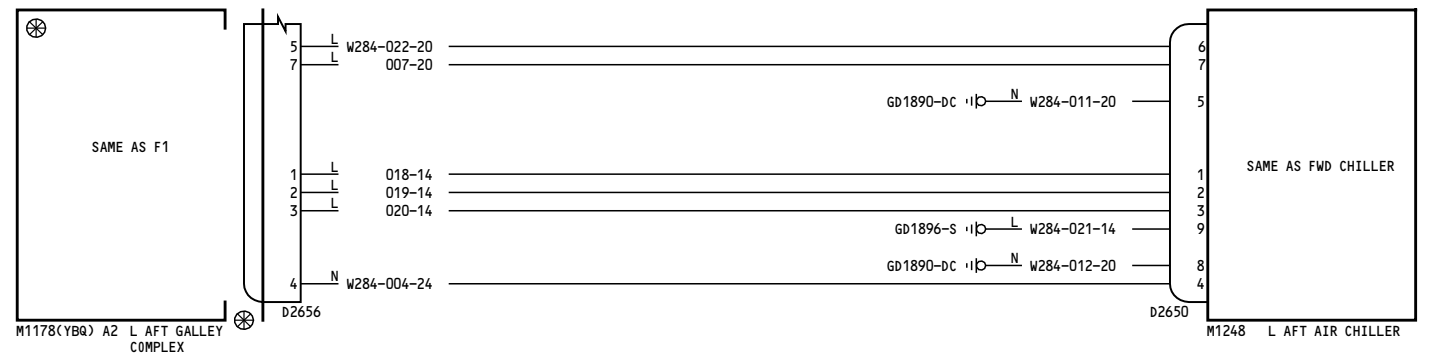
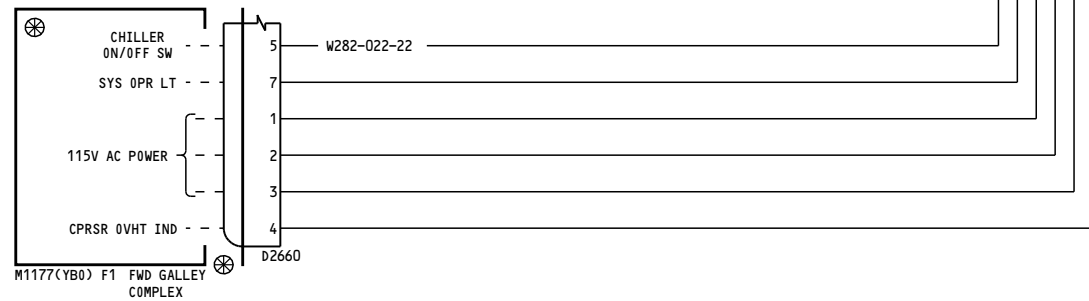
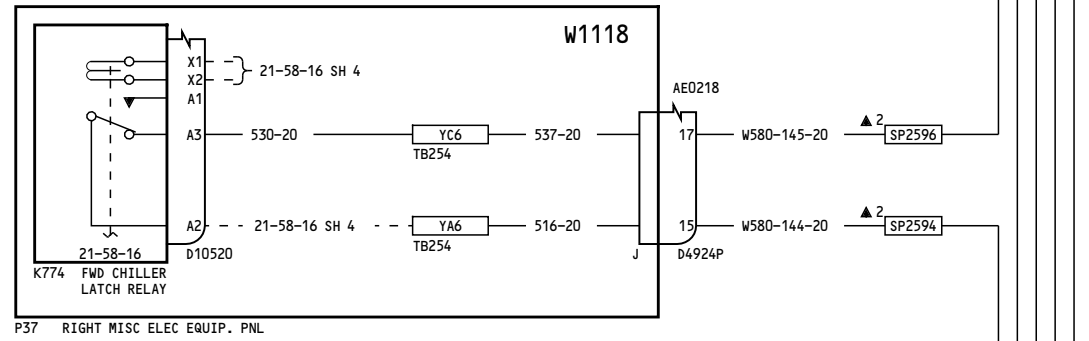
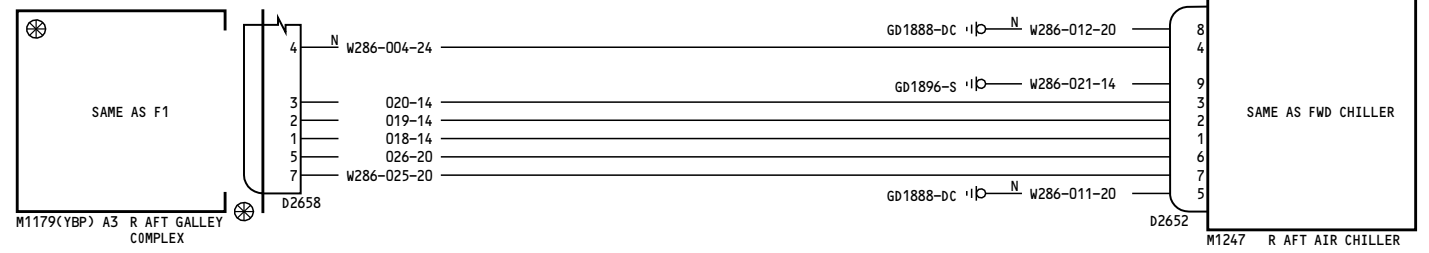
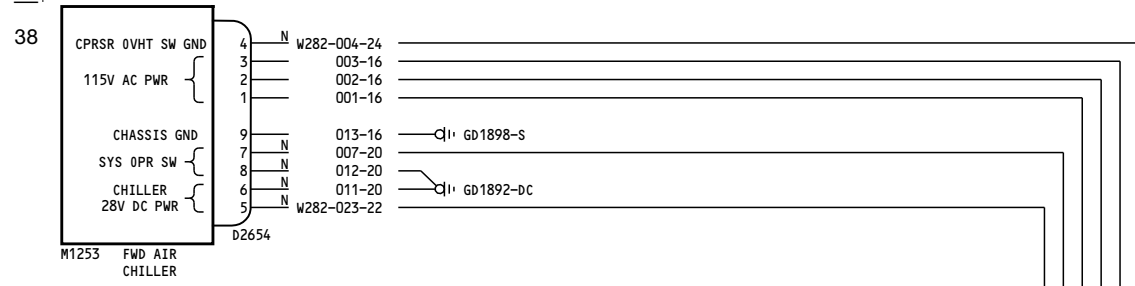

275-276

REFRIGERATION POWER

D280T132

25-33-11

Page 7

Jan 21/2005

25-33-11

Page 7

Jan 21/2005

240

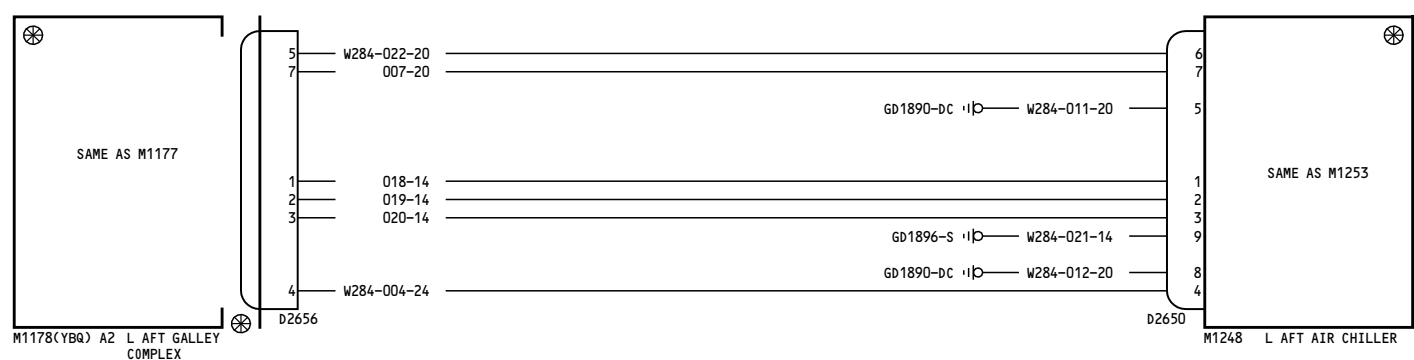
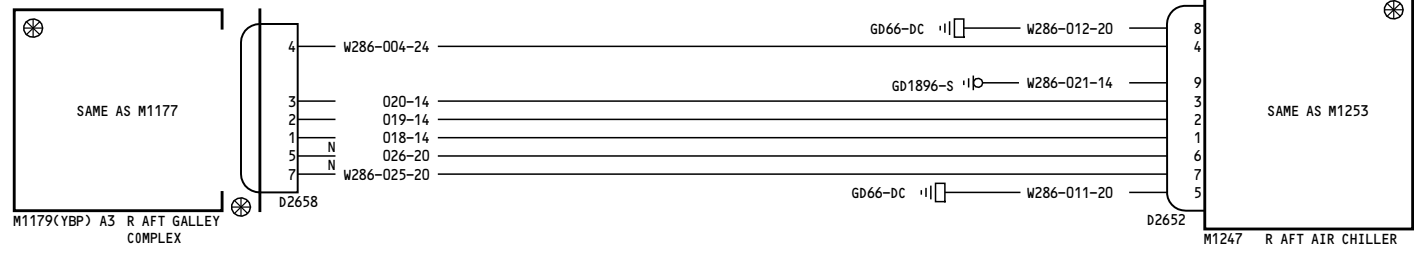
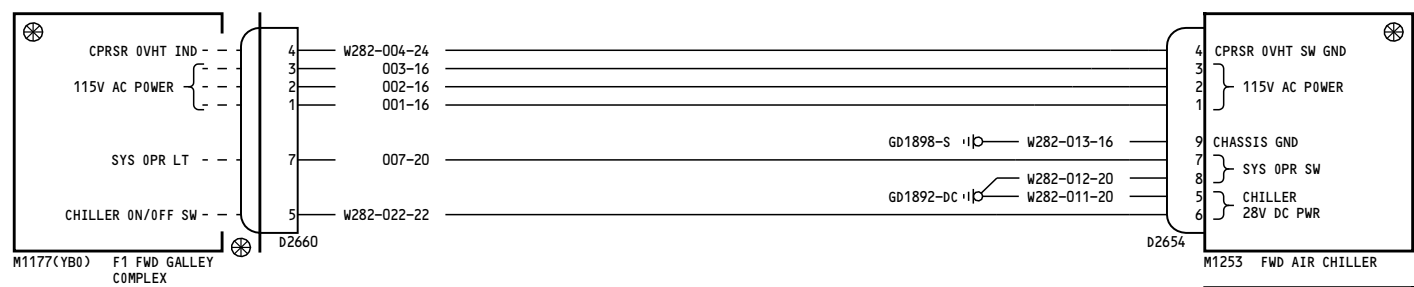
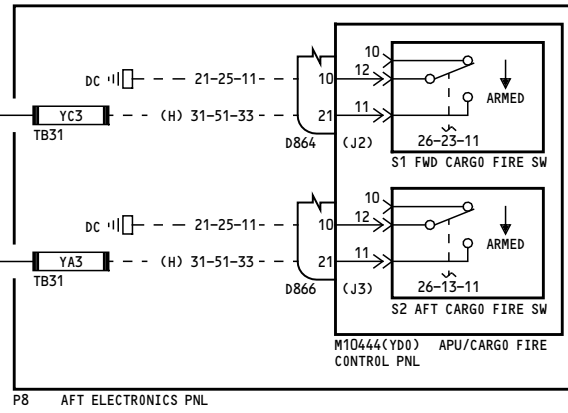
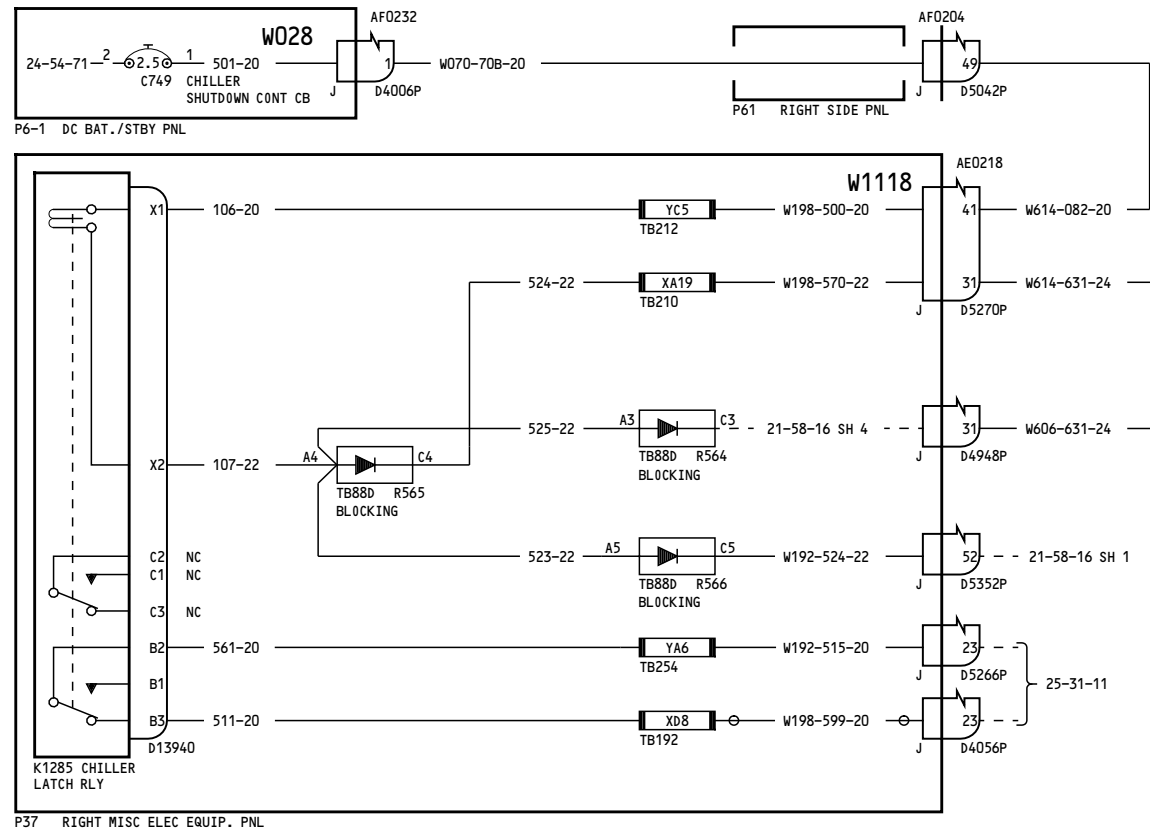

277

REFRIGERATION POWER

D280T132

25-33-11

Page 8.1

Jan 21/2005

Incorporates
25-0180 R05

25-33-11

Page 8.1

Jan 21/2005

59

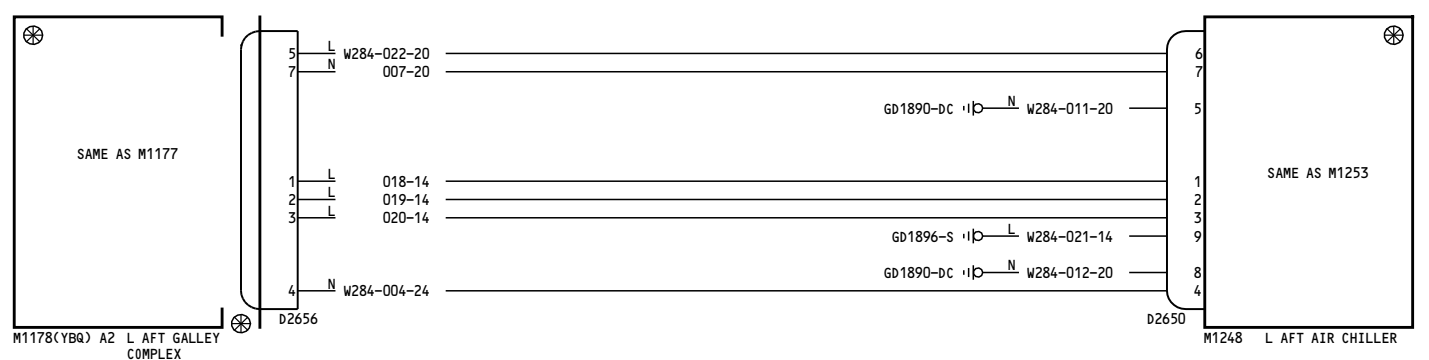
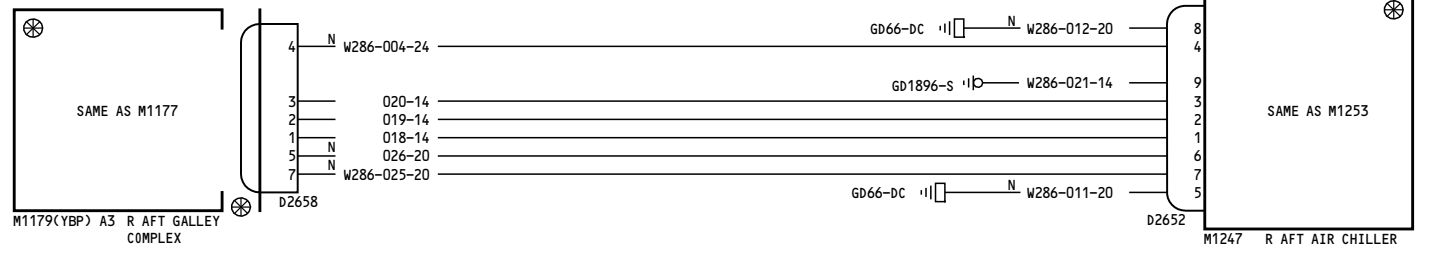
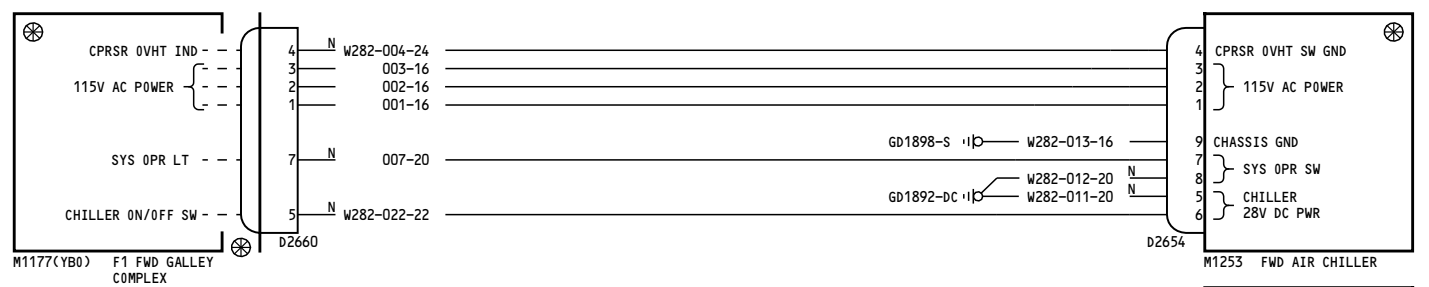
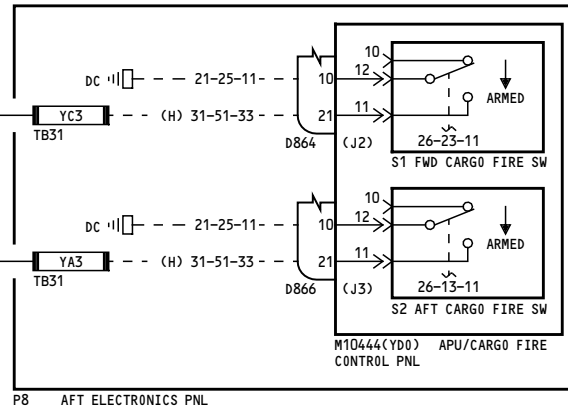
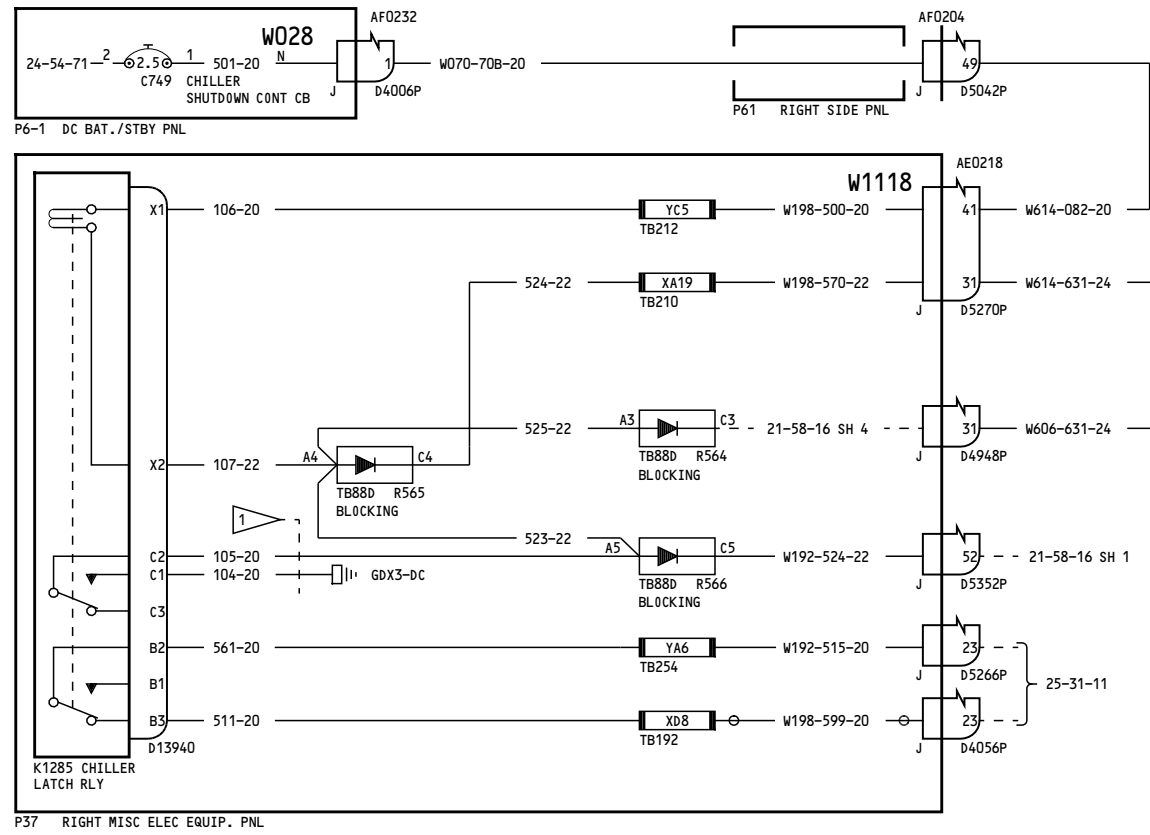

NOTES:
1 VN223-VN223 (277)

278

REFRIGERATION POWER

D280T132

25-33-11

Page 9

Jan 21/2005

25-33-11

Page 9

Jan 21/2005

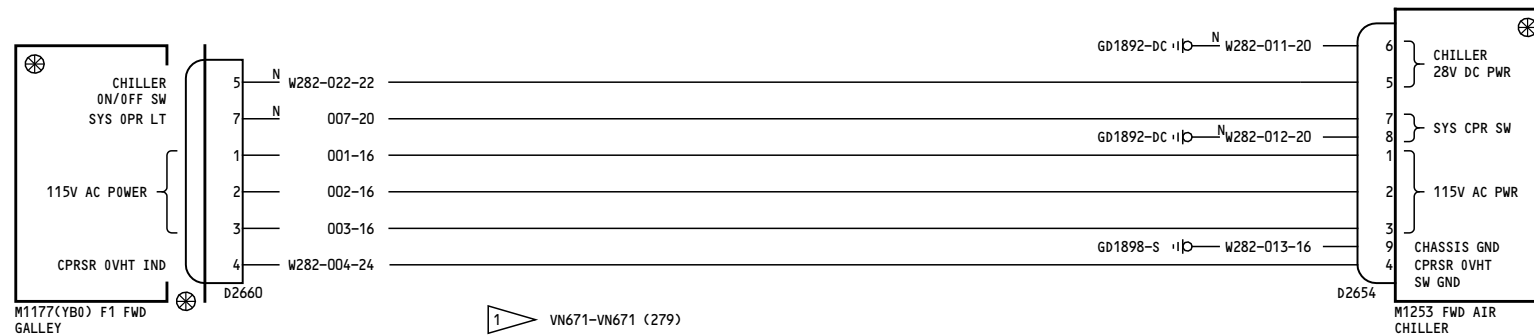
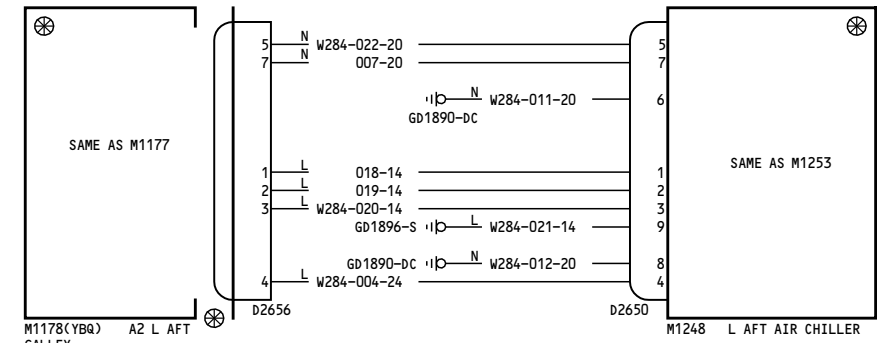
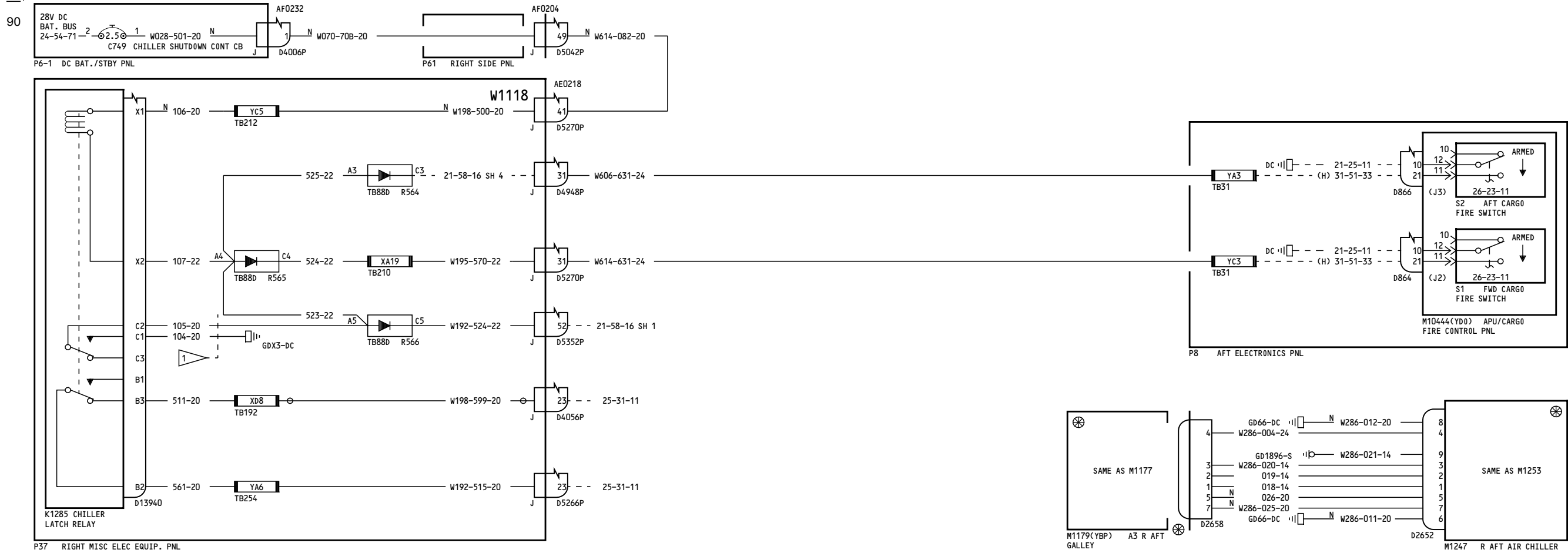

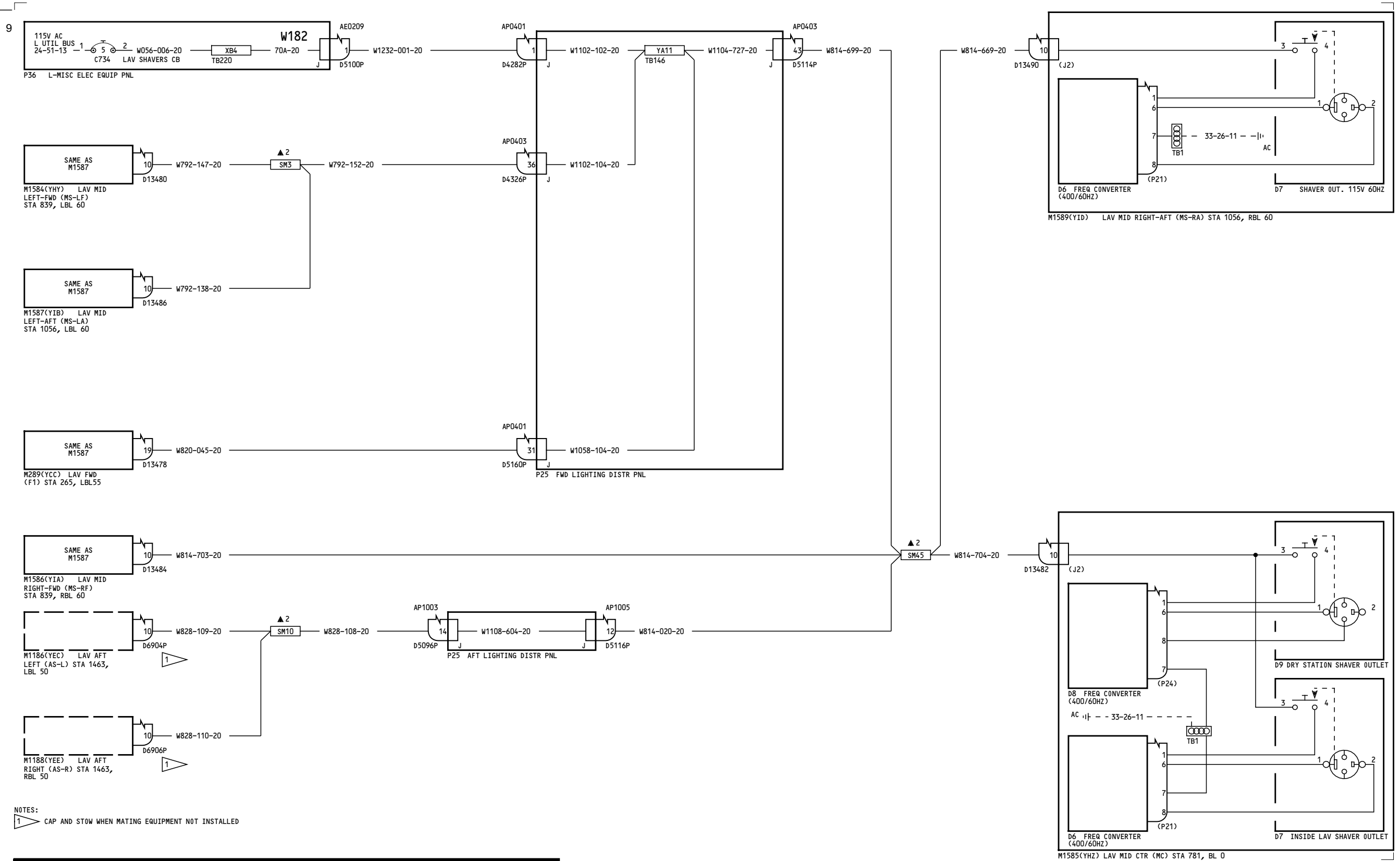

NOTES:
1 CAP AND STOW WHEN MATING EQUIPMENT NOT INSTALLED

050-099	SHAVERS OUTLETS-LAVATORY
	D280T132

25-42-11

Page 1

Jan 21/2005

25-42-11

Page 1

Jan 21/2005

5

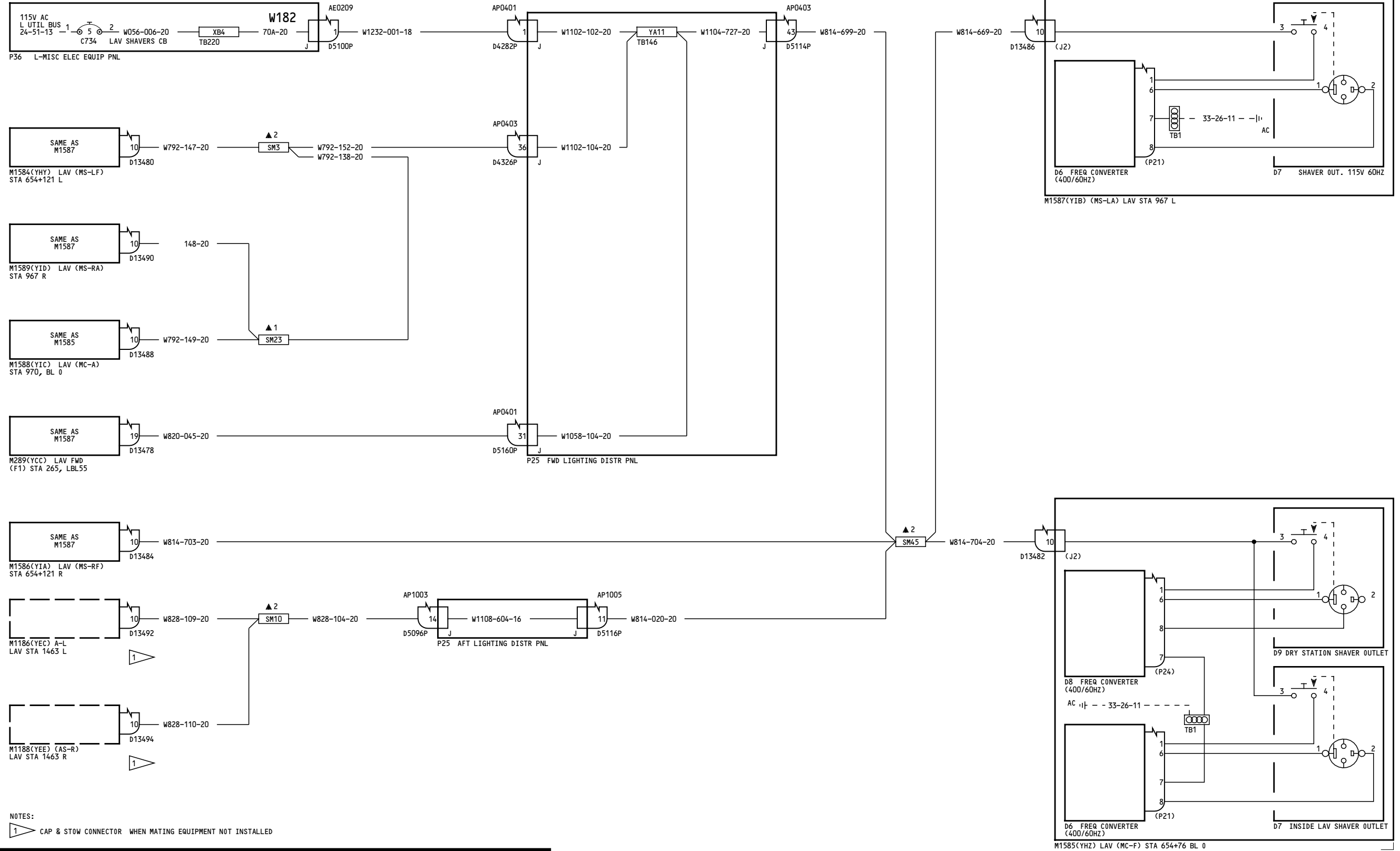

150-157

SHAVR OUTLETS-
LAVATORY

25-42-11

Page 2

D280T132

Jan 21/2005

25-42-11

Page 2

Jan 21/2005

11

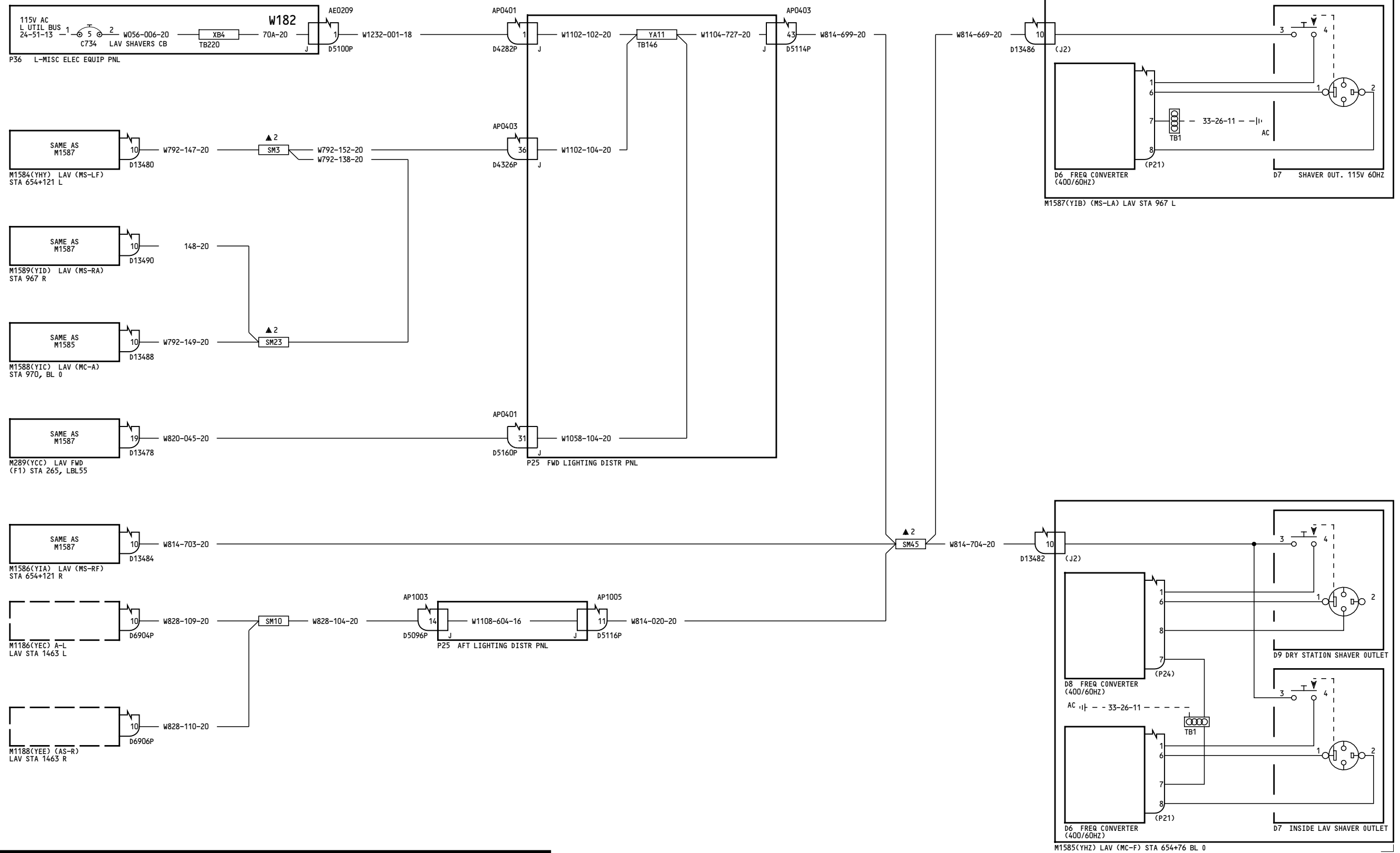

162-199

SHAVER OUTLETS-
LAVATORY

25-42-11

Page 3

D280T132

Jan 21/2005

25-42-11

Page 3

Jan 21/2005

-A
7

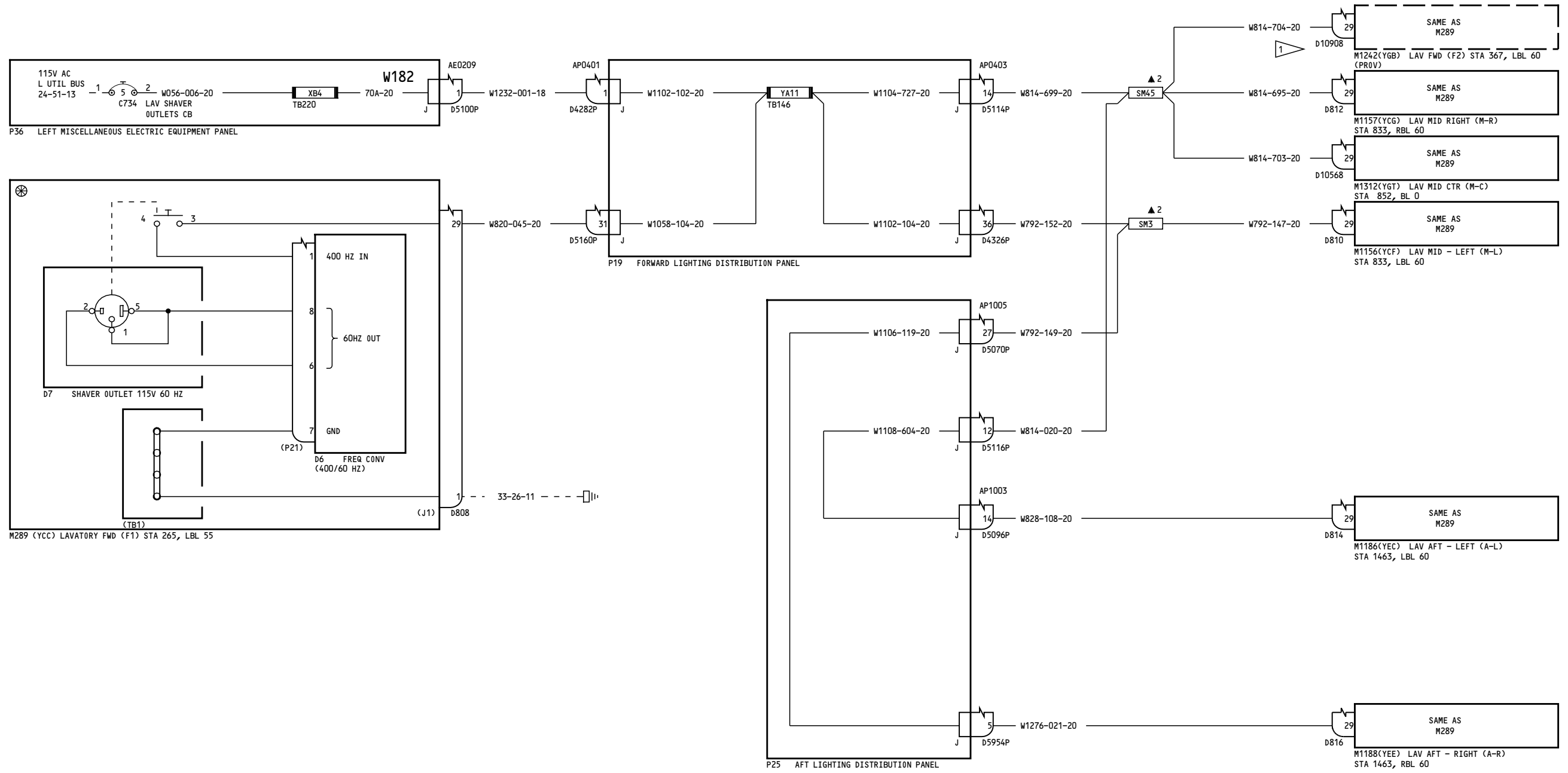

NOTES:
 1 CAP AND STOW WHEN MATING EQUIPMENT NOT INSTALLED

275-278	<p align="center">SHAVER OUTLETS- LAVATORY</p> <p align="center">D280T132</p>
---------	--

25-42-11
 Page 4
 Jan 21/2005

25-42-11
 Page 4
 Jan 21/2005

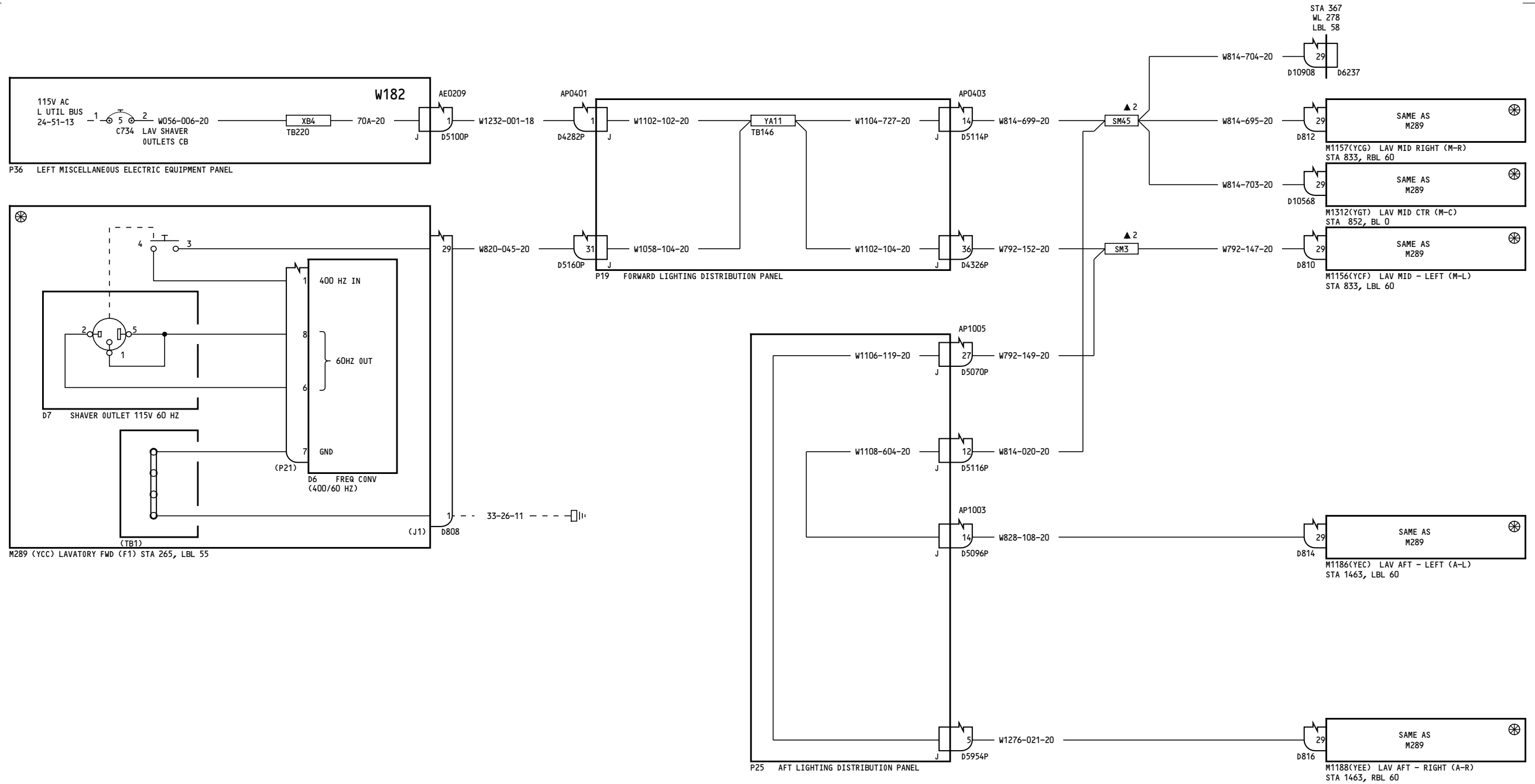

280-299

**SHAVER OUTLETS-
LAVATORY**

25-42-11

Page 5

Jan 21/2005

D280T132

25-42-11

Page 5

Jan 21/2005

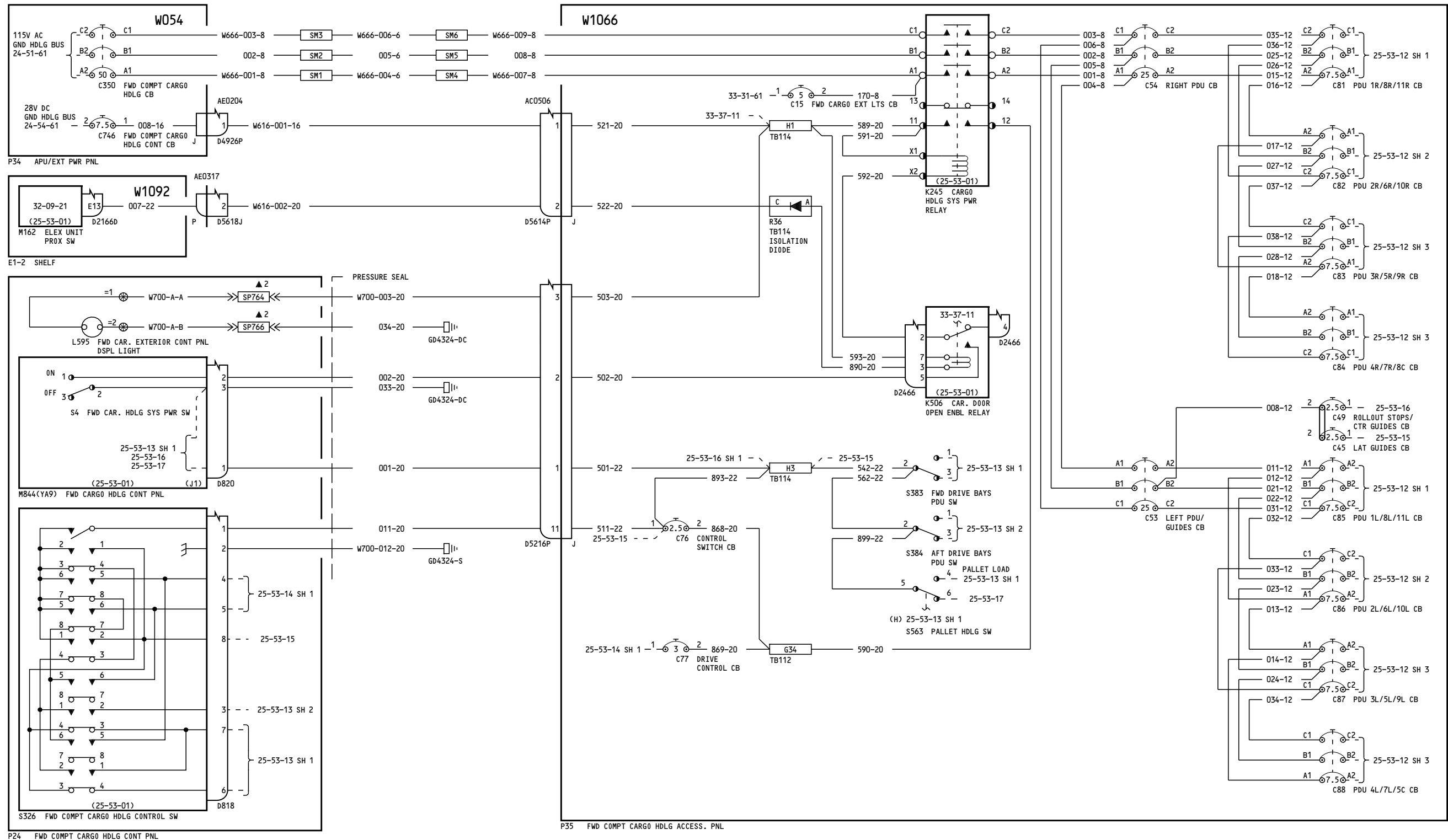

050-099

CARGO HANDLING-FORWARD LOWER LOBE POWER DISTRIBUTION

25-53-11

Page 1

Jan 21/2005

D280T132

25-53-11

Page 1

Jan 21/2005

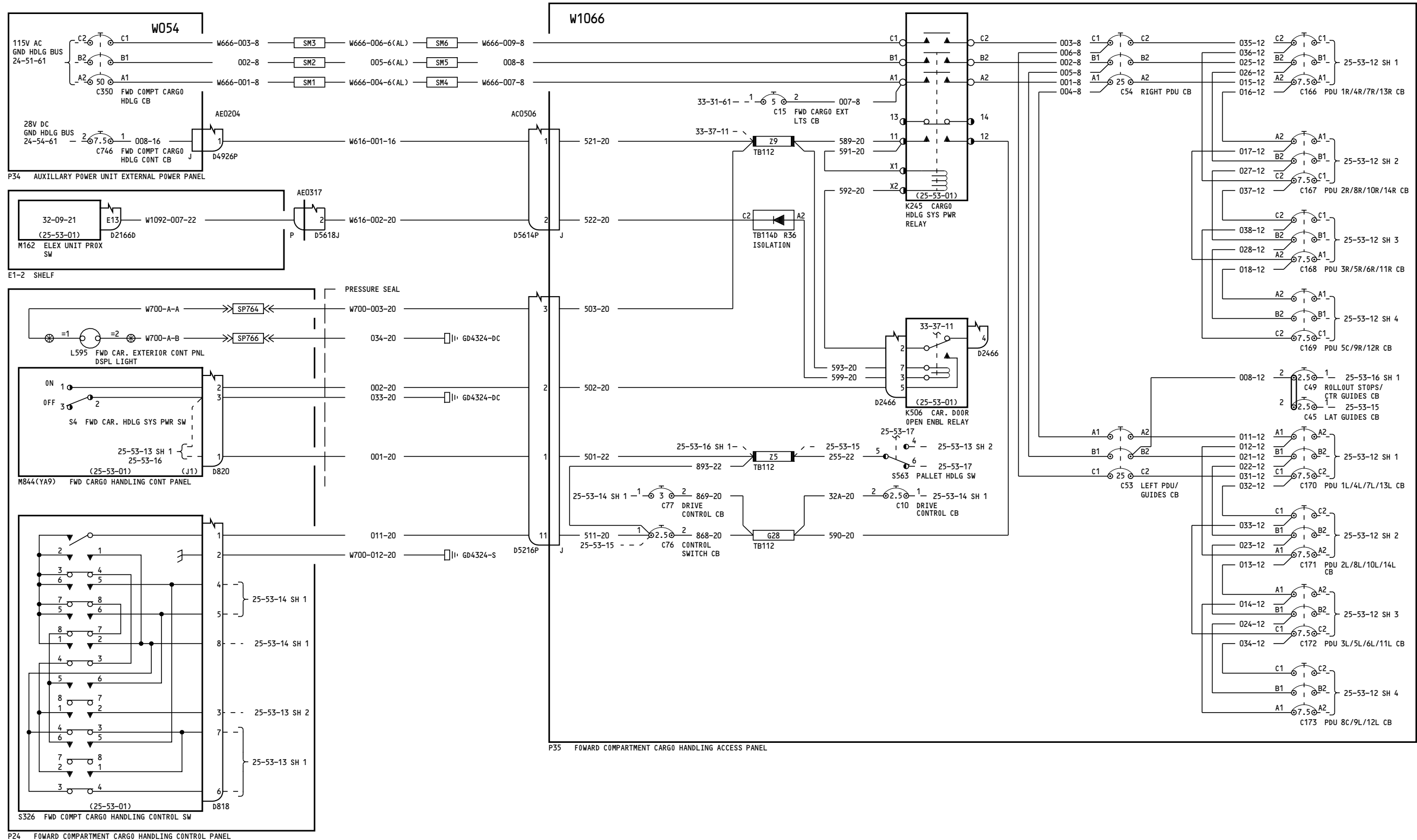

150-199, 275-299

**CARGO HANDLING-
FORWARD LOWER LOBE
POWER DISTRIBUTION**

D280T132

25-53-11

Page 2

Jan 21/2005

25-53-11

Page 2

Jan 21/2005

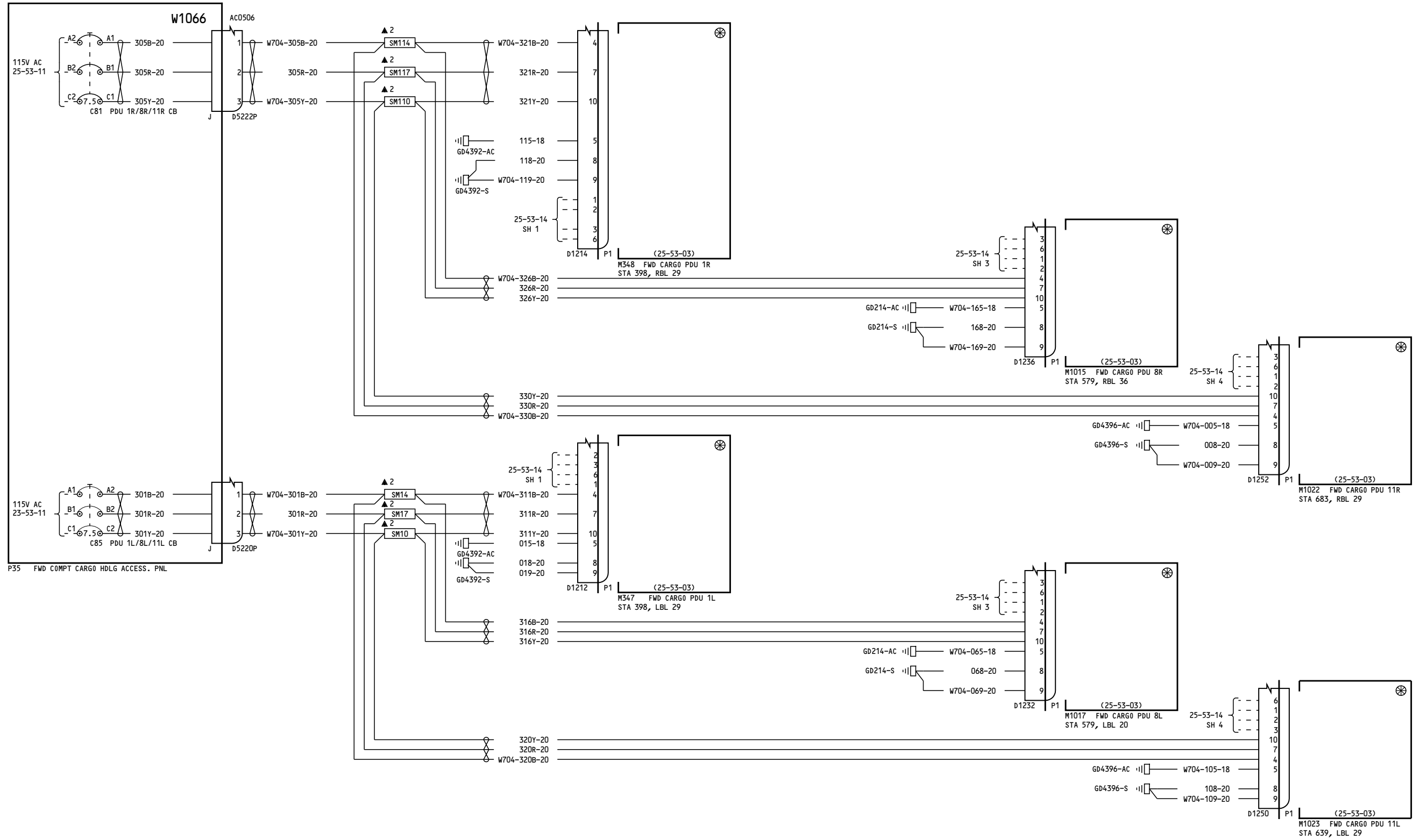

050-099

**CARGO HANDLING-
FORWARD LOWER LOBE
PDU POWER**

D280T132

25-53-12

Page 1
Sheet 1
Jan 21/2005

25-53-12

Page 1
Sheet 1
Jan 21/2005

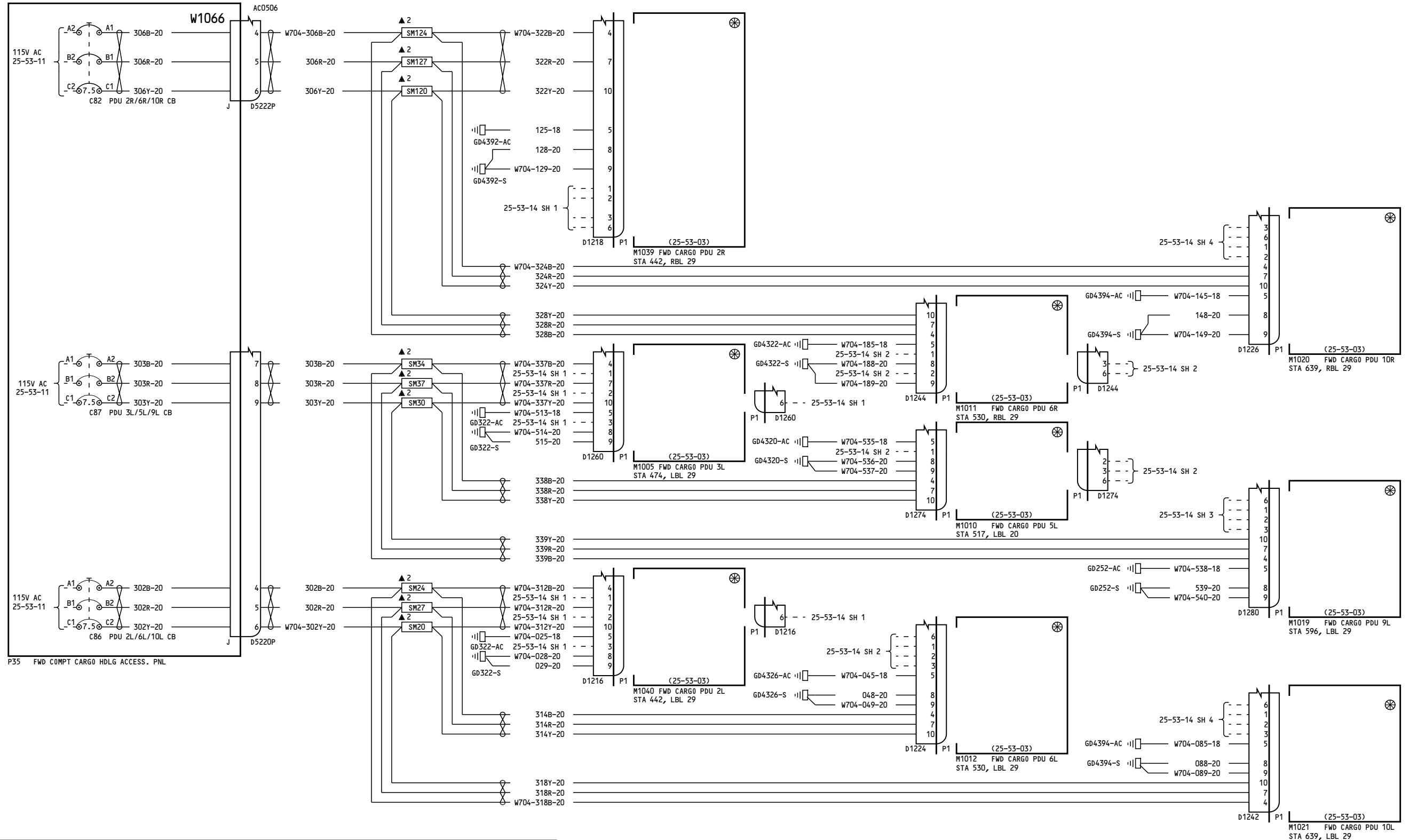

050-099

CARGO HANDLING-
FORWARD LOWER LOBE
PDU POWER

D280T132

25-53-12

Page 1
Sheet 2
Jan 21/2005

25-53-12

Page 1
Sheet 2
Jan 21/2005

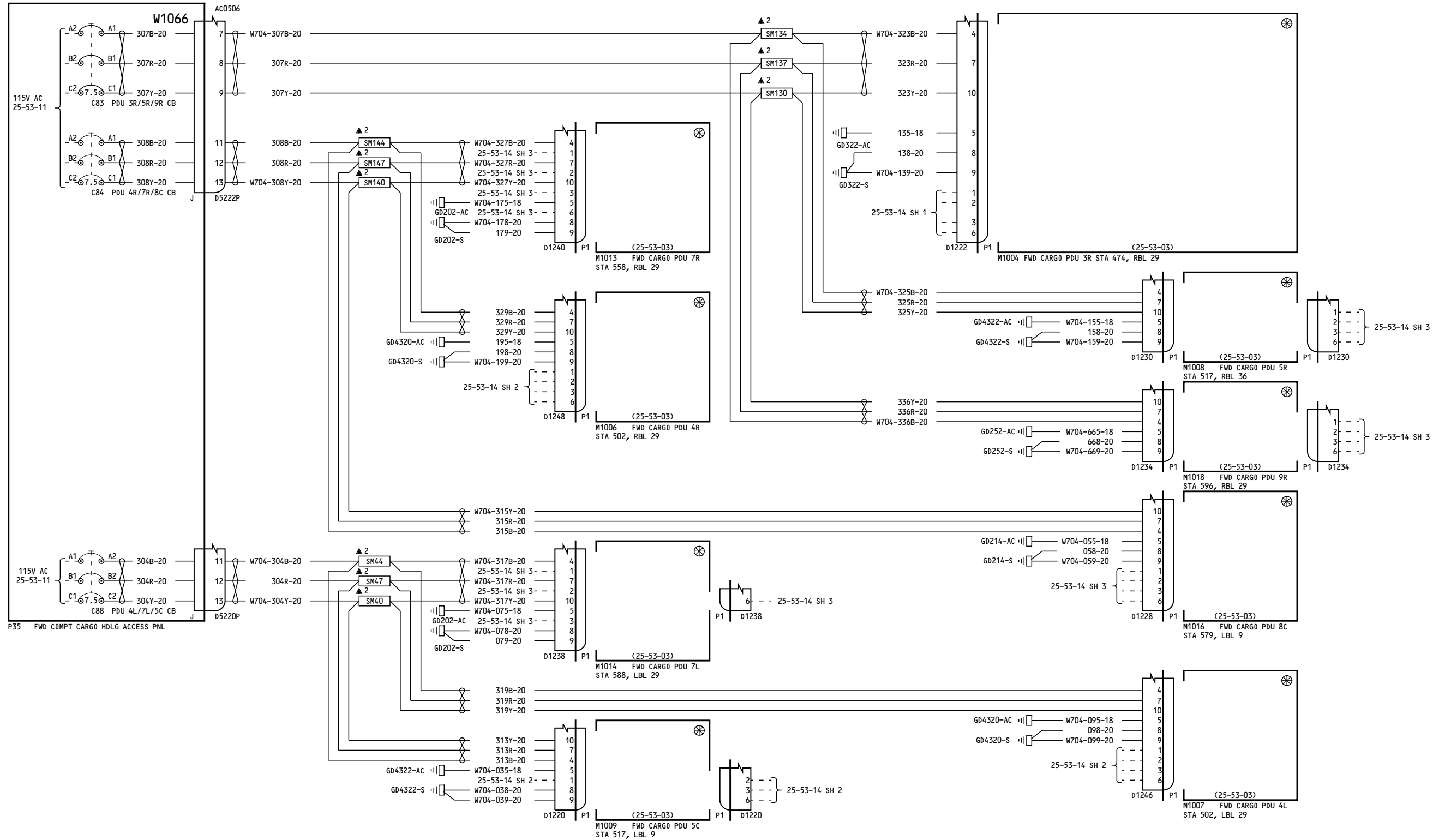

050-099

CARGO HANDLING-FORWARD LOWER LOBE PDU POWER

D280T132

25-53-12

Page 1
Sheet 3
Jan 21/2005

25-53-12

Page 1
Sheet 3
Jan 21/2005

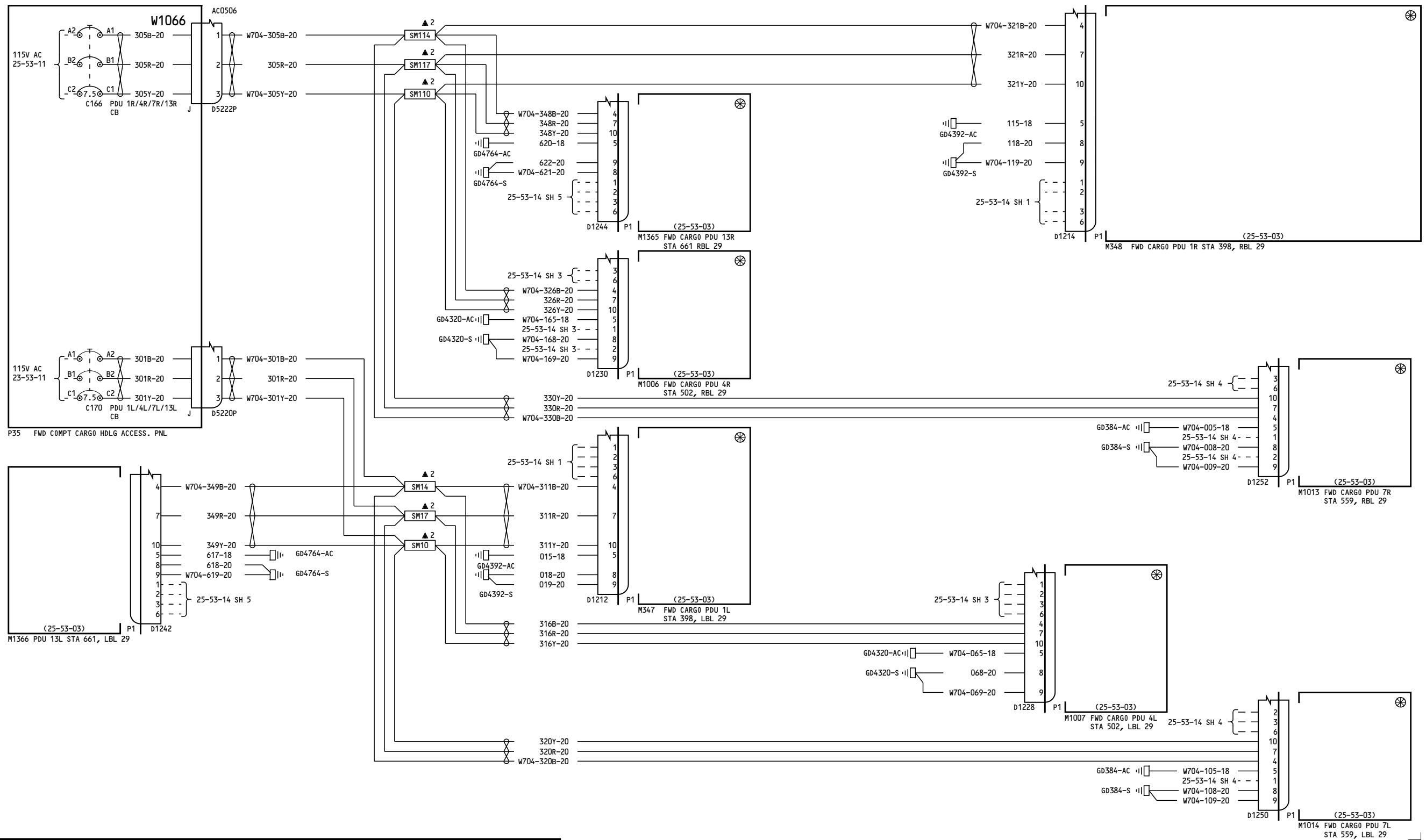

150-199, 275-278

**CARGO HANDLING-
FORWARD LOWER LOBE
PDU POWER**

D280T132

25-53-12

Page 2
Sheet 1
Jan 21/2005

25-53-12

Page 2
Sheet 1
Jan 21/2005

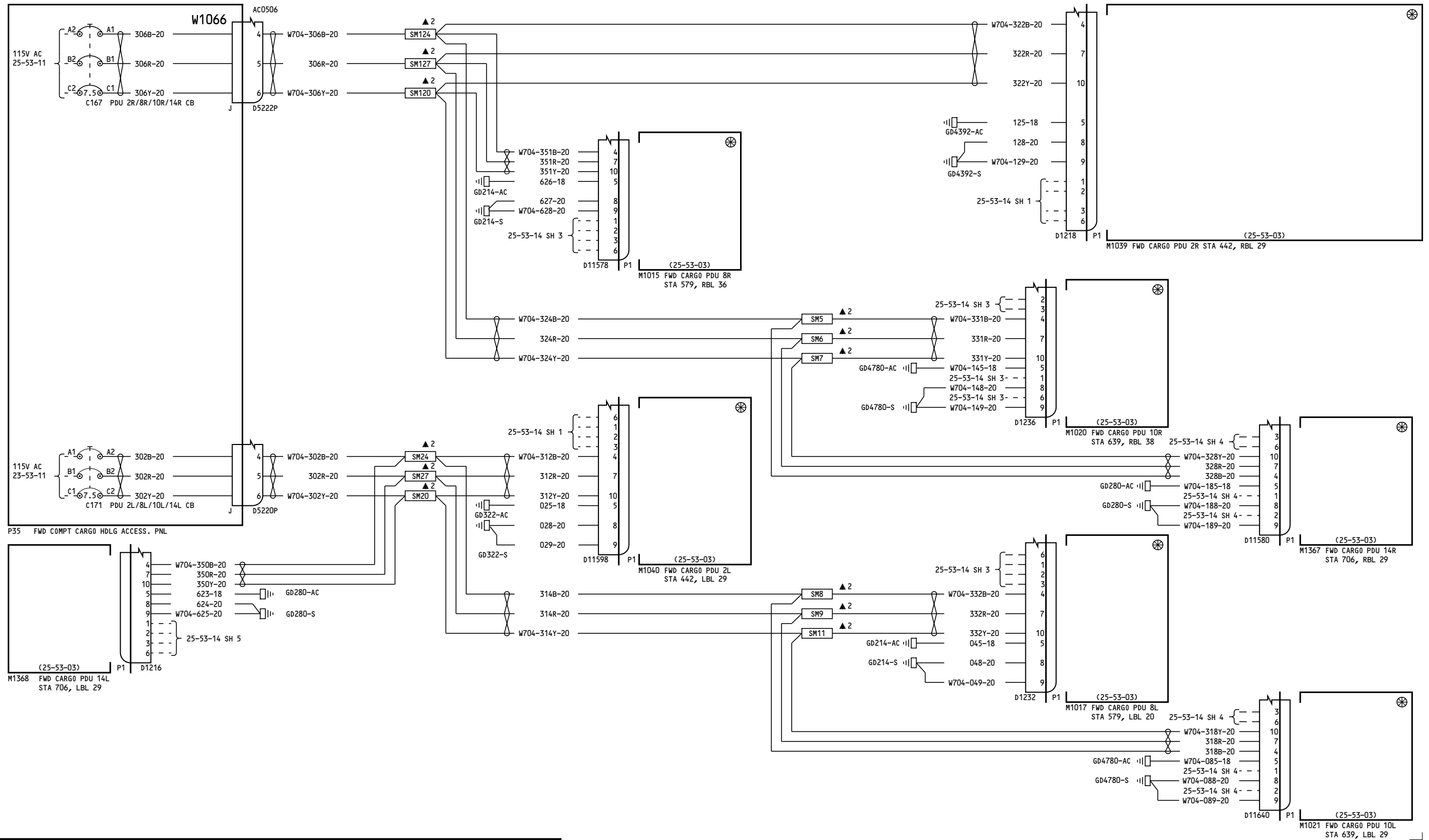

150-199, 275-278

**CARGO HANDLING-
FORWARD LOWER LOBE
PDU POWER**

D280T132

25-53-12

Page 2
Sheet 2
Jan 21/2005

25-53-12

Page 2
Sheet 2
Jan 21/2005

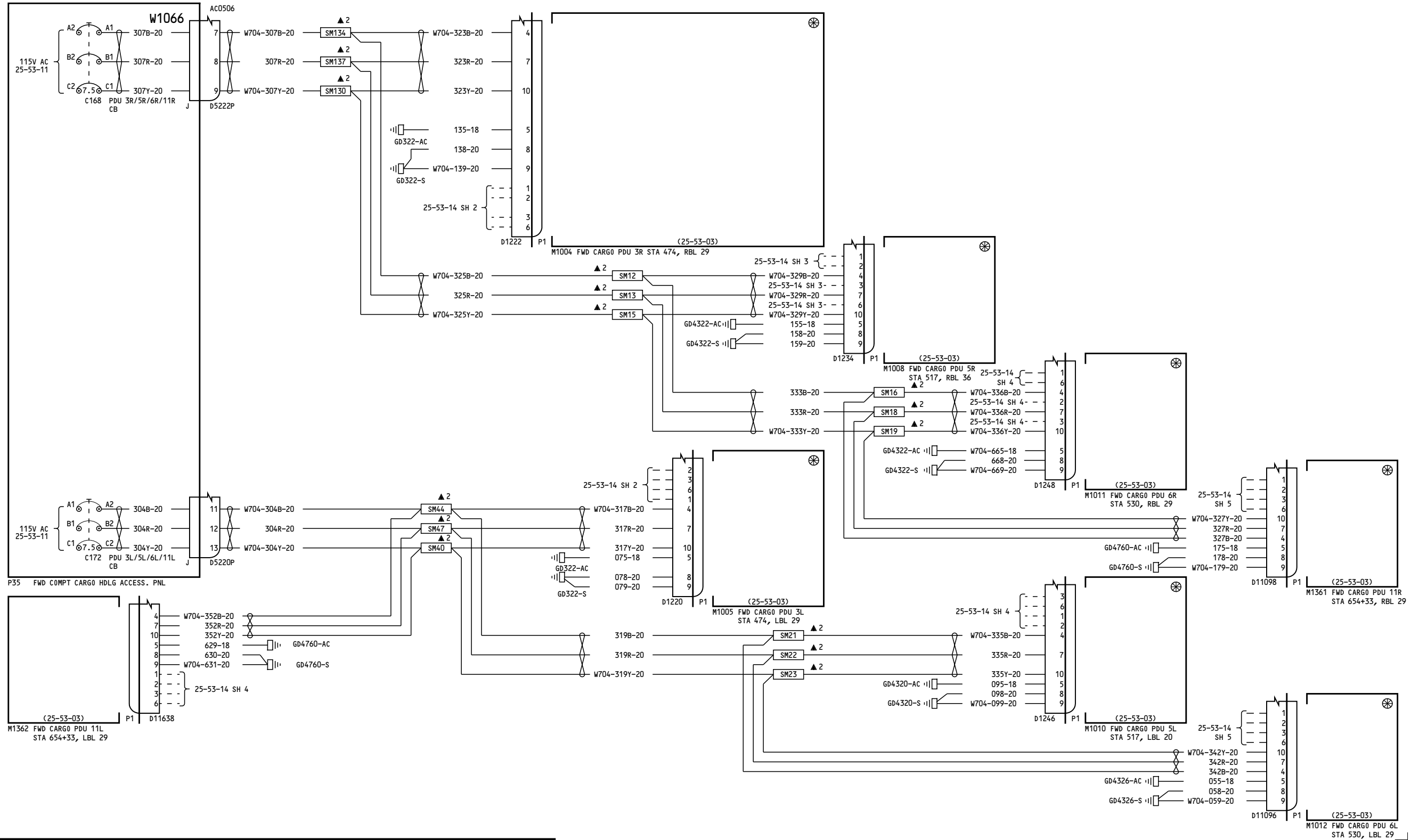

150-199, 275-278

CARGO HANDLING- FORWARD LOWER LOBE PDU POWER

D280T132

25-53-12

Page 2 Sheet 3 Jan 21/2005

25-53-12

Page 2 Sheet 3 Jan 21/2005

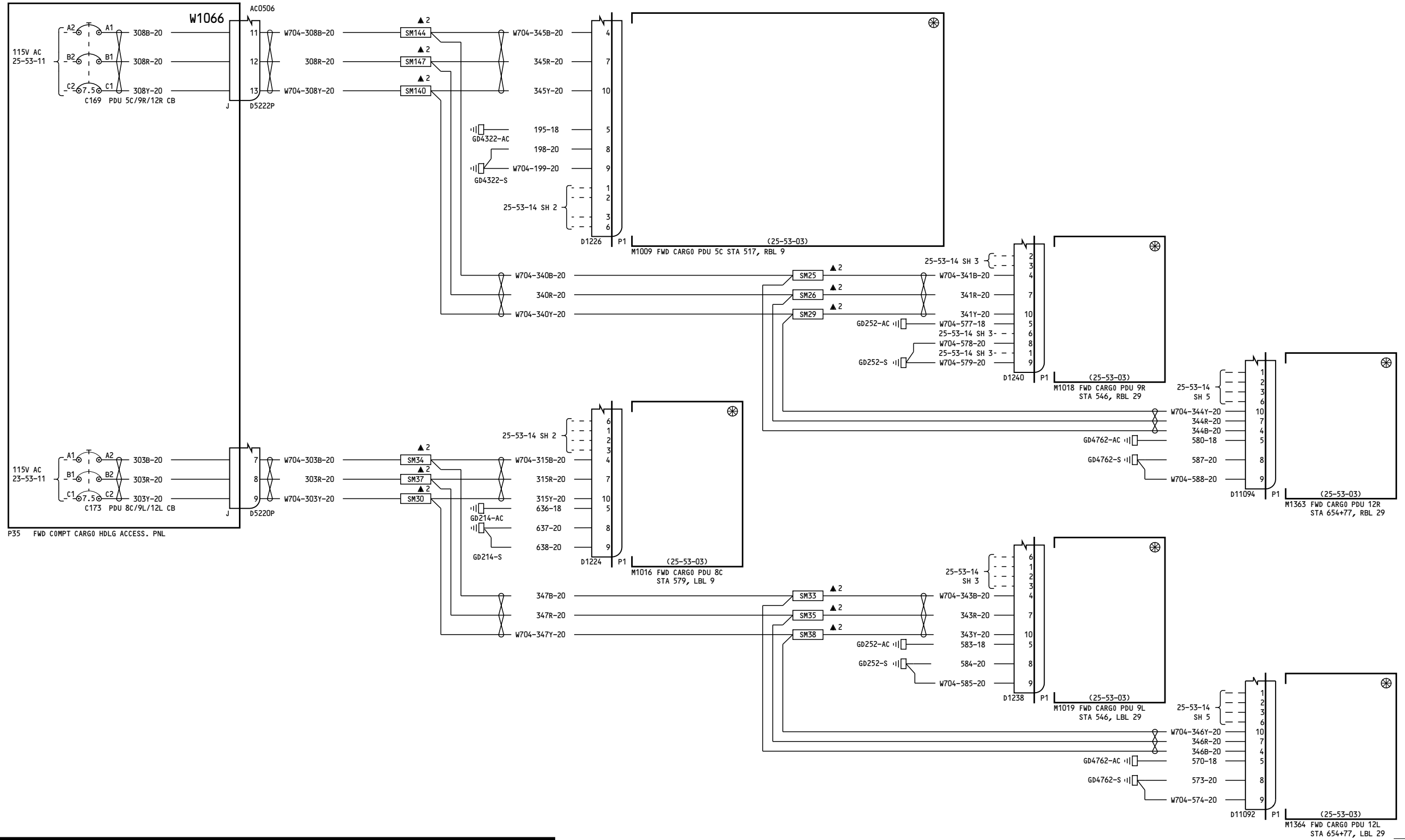

150-199, 275-278

**CARGO HANDLING-
FORWARD LOWER LOBE
PDU POWER**

D280T132

25-53-12

Page 2
Sheet 4
Jan 21/2005

25-53-12

Page 2
Sheet 4
Jan 21/2005

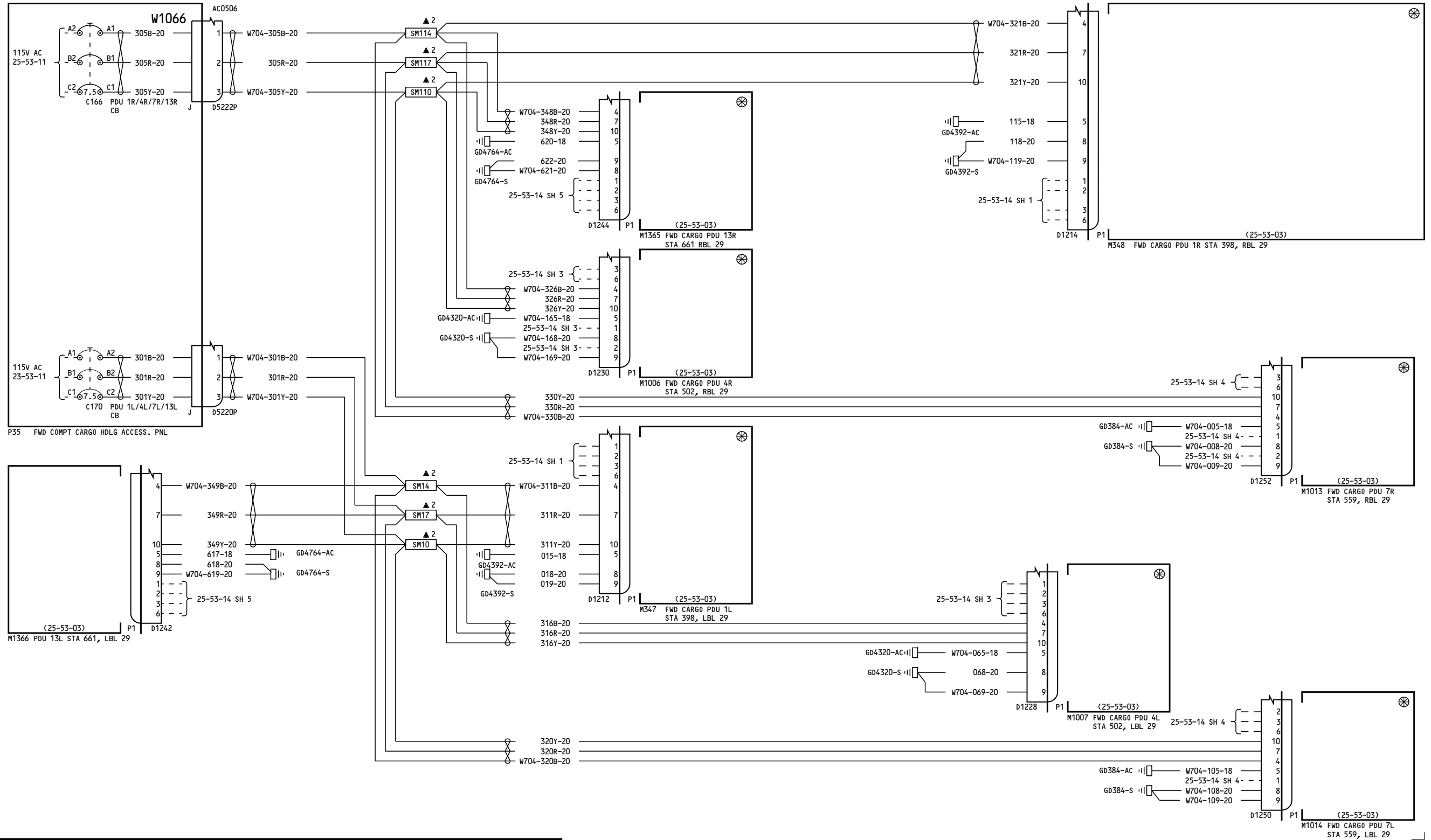

280-299

**CARGO HANDLING-
FORWARD LOWER LOBE
PDU POWER**

D280T132

25-53-12

Page 3
Sheet 1
Jan 21/2005

25-53-12

Page 3
Sheet 1
Jan 21/2005

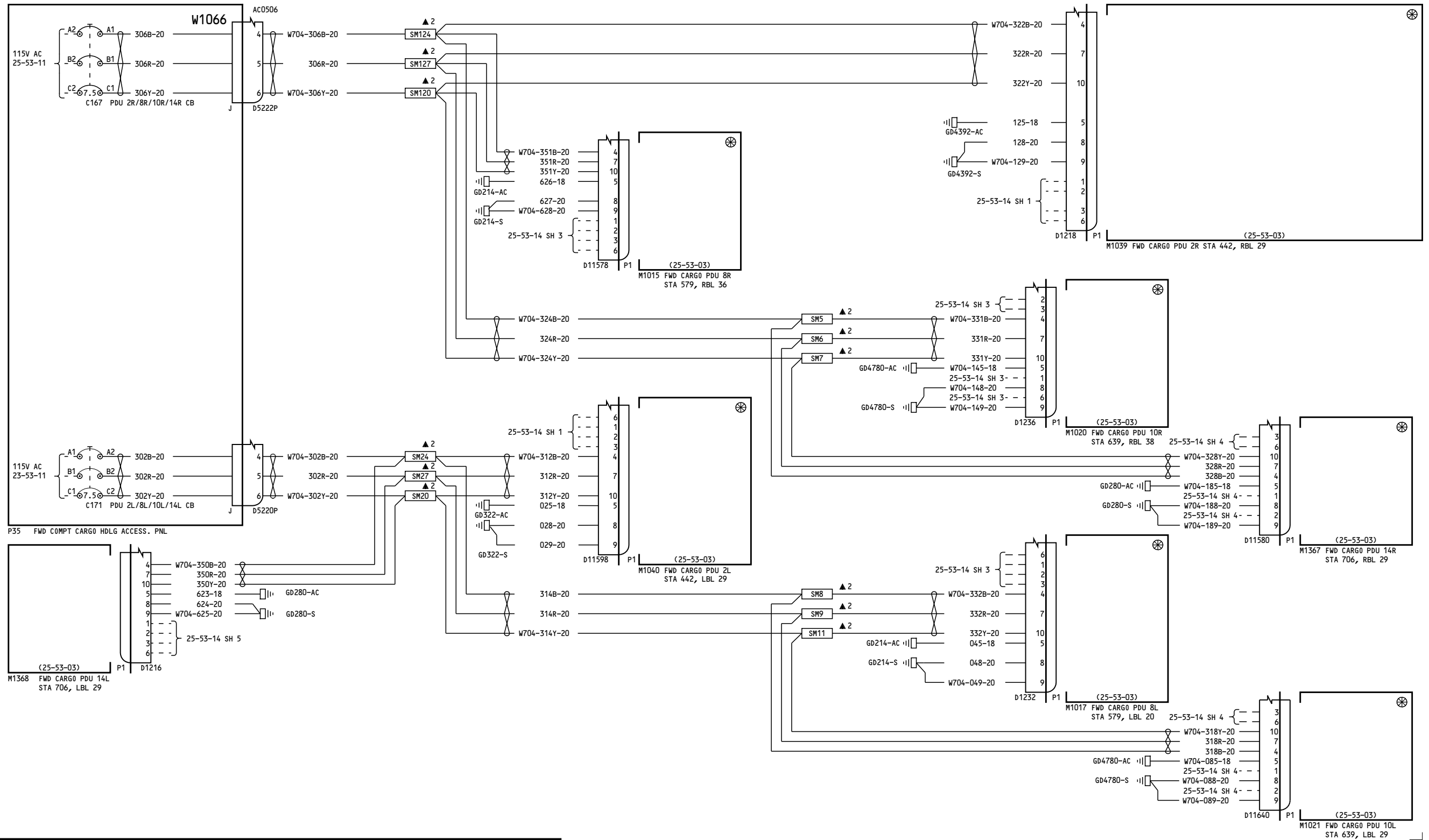

280-299

**CARGO HANDLING-
FORWARD LOWER LOBE
PDU POWER**

25-53-12

Page 3
Sheet 2
Jan 21/2005

D280T132

25-53-12

Page 3
Sheet 2
Jan 21/2005

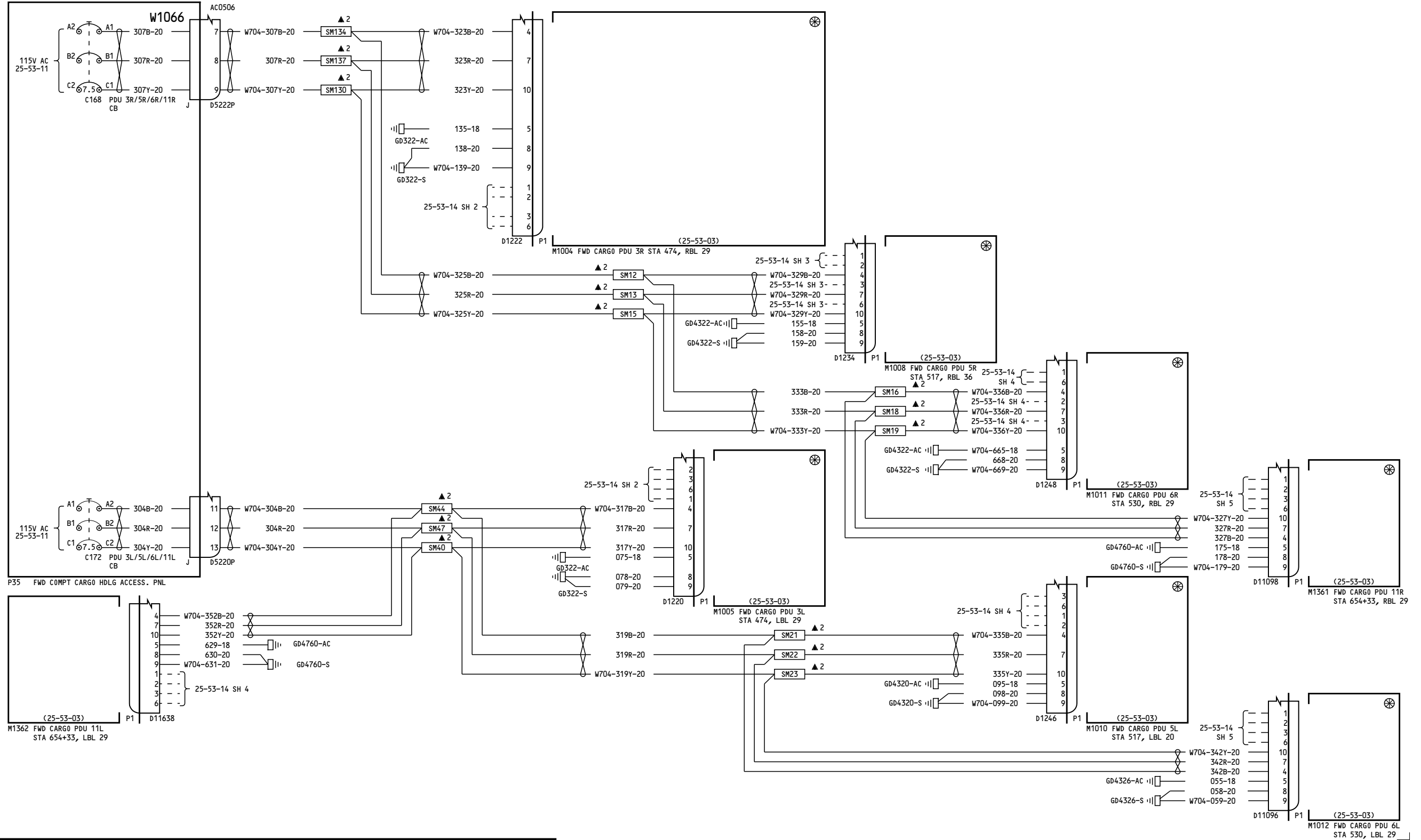

280-299

**CARGO HANDLING-
FORWARD LOWER LOBE
PDU POWER**

25-53-12

Page 3
Sheet 3
Jan 21/2005

D280T132

25-53-12

Page 3
Sheet 3
Jan 21/2005

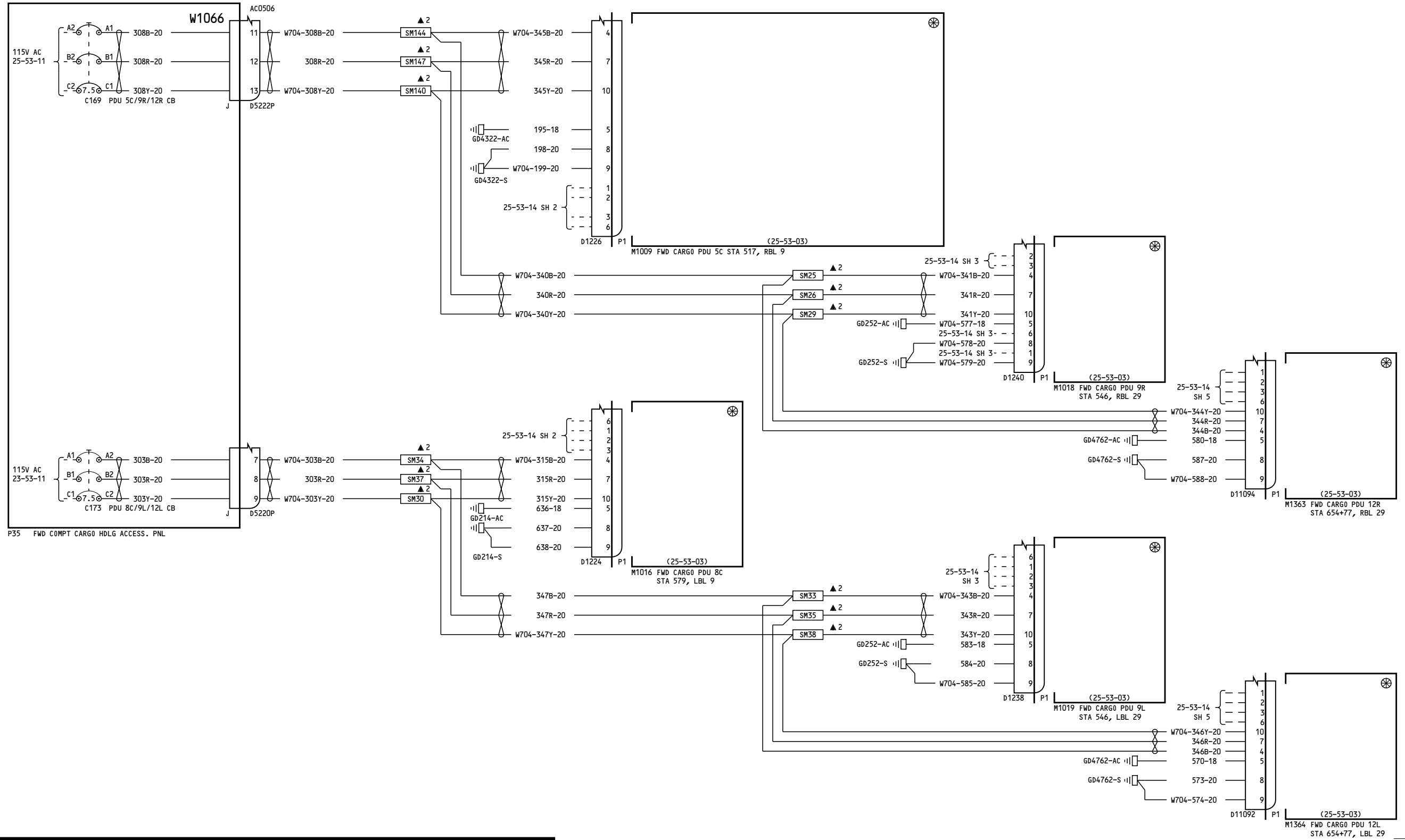

280-299

**CARGO HANDLING-
FORWARD LOWER LOBE
PDU POWER**

D280T132

25-53-12

Page 3
Sheet 4
Jan 21/2005

25-53-12

Page 3
Sheet 4
Jan 21/2005

-B
40

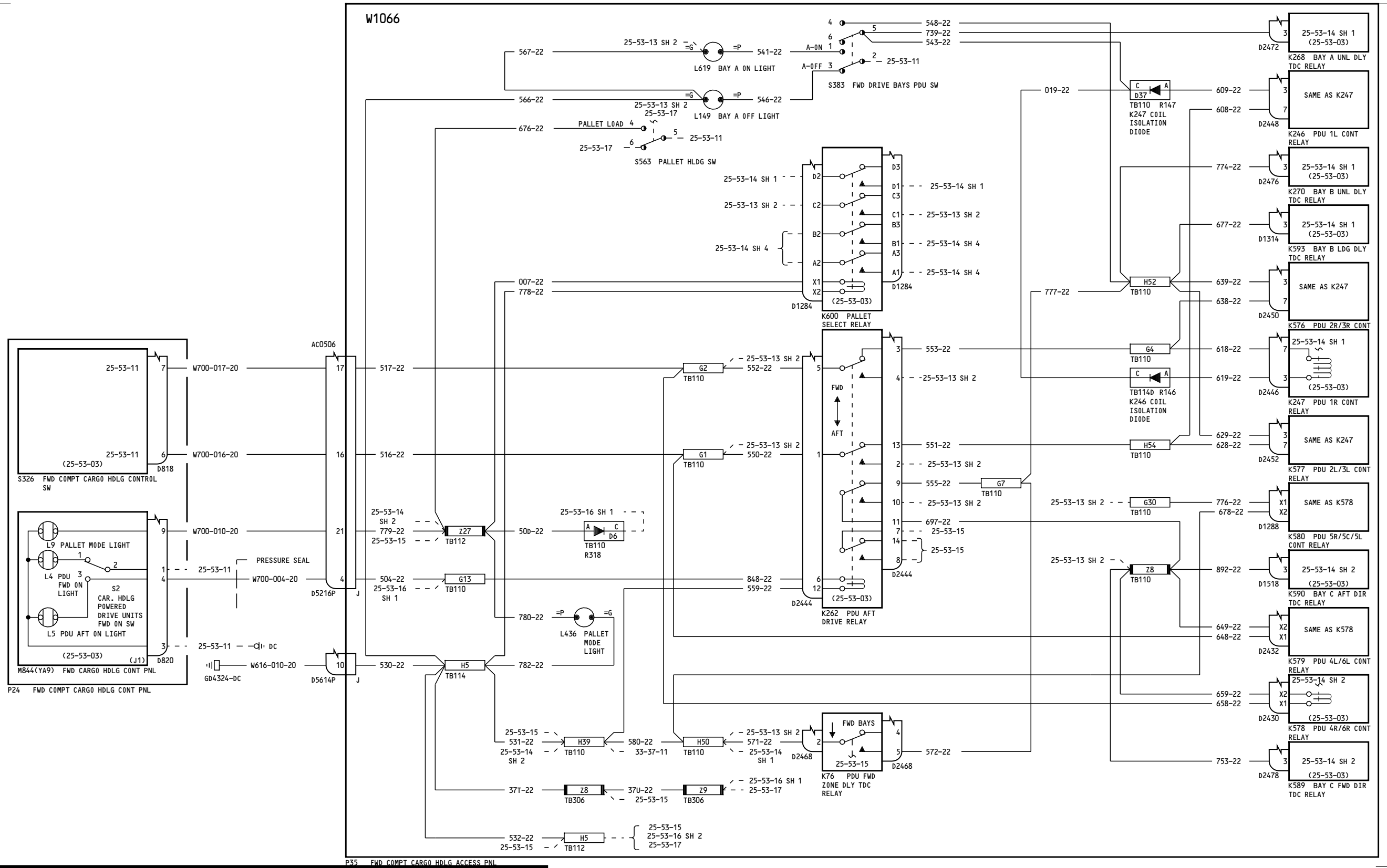

050-099

**CARGO HANDLING-
FORWARD LOWER LOBE
FWD/AFT PDU CONTROL**

D280T132

25-53-13

Page 1
Sheet 1
Jan 21/2005

25-53-13

Page 1
Sheet 1
Jan 21/2005

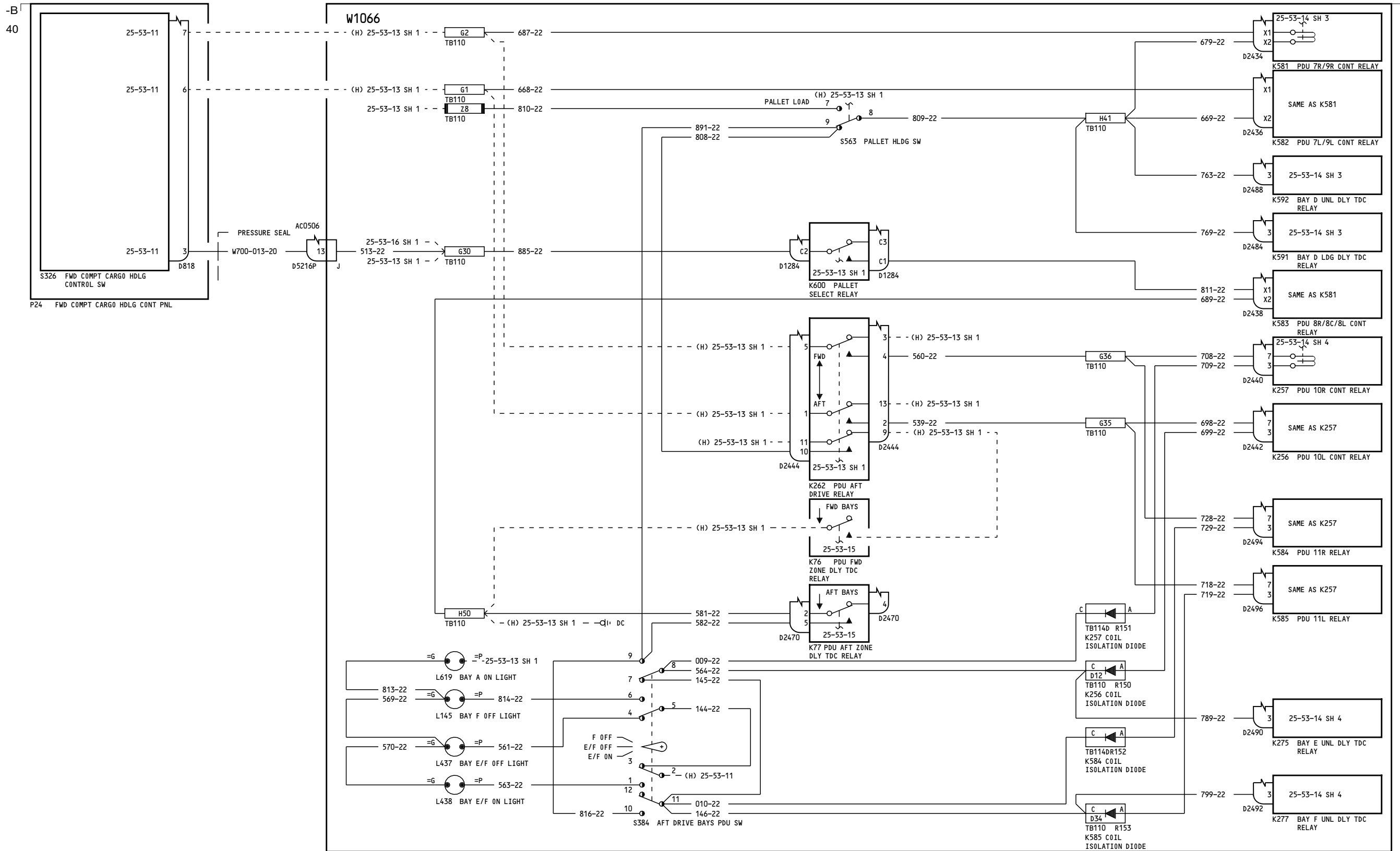

050-099

P35 FWD COMPT CARGO HDLG ACCESS PNL

CARGO HANDLING-FORWARD LOWER LOBE FWD/AFT PDU CONTROL

25-53-13

Page 1 Sheet 2 Jan 21/2005

D280T132

25-53-13

Page 1 Sheet 2 Jan 21/2005

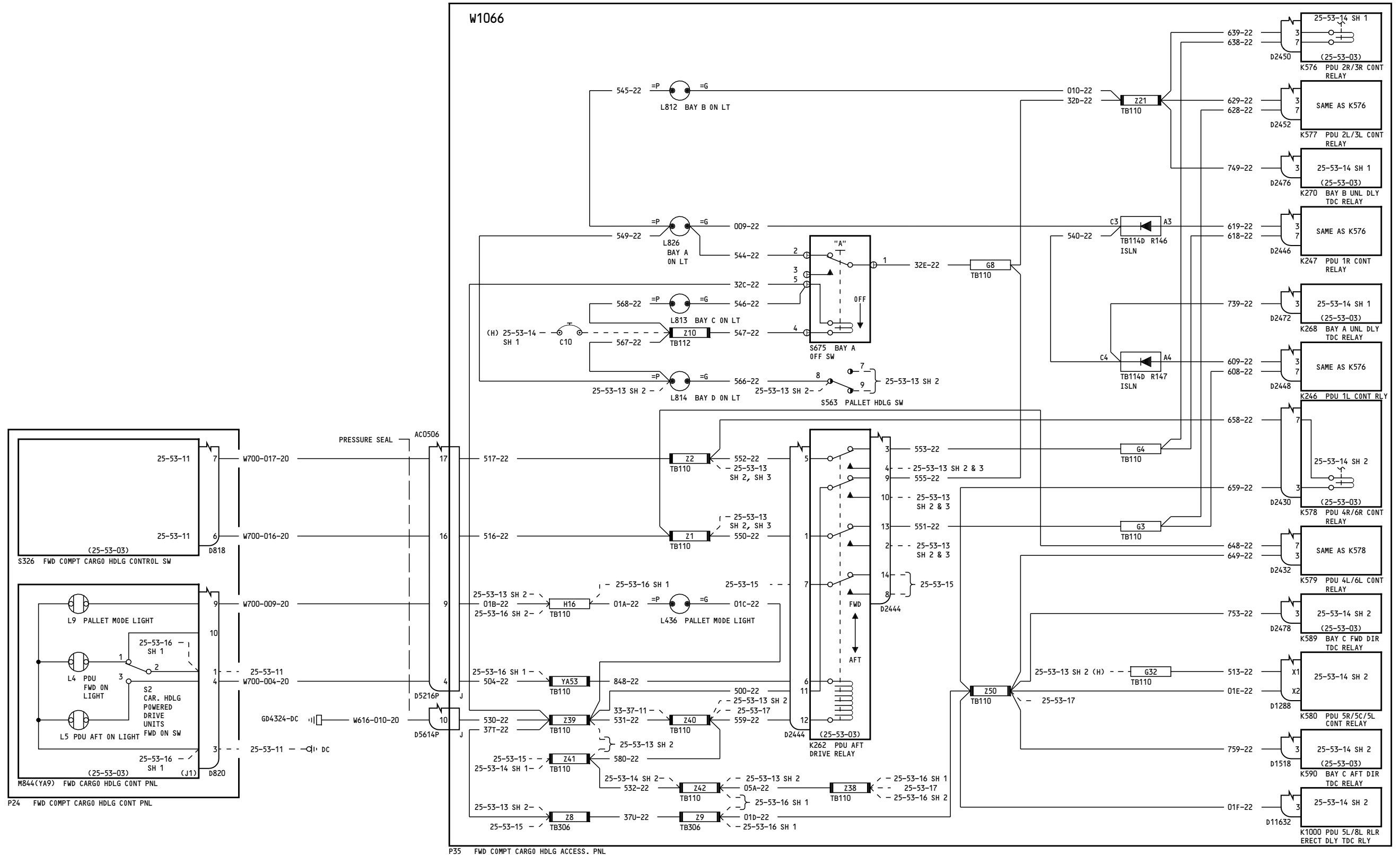

150-199, 275-299

**CARGO HANDLING-
FORWARD LOWER LOBE
FWD/AFT PDU CONTROL**

25-53-13

Page 2
Sheet 1
Jan 21/2005

D280T132

25-53-13

Page 2
Sheet 1
Jan 21/2005

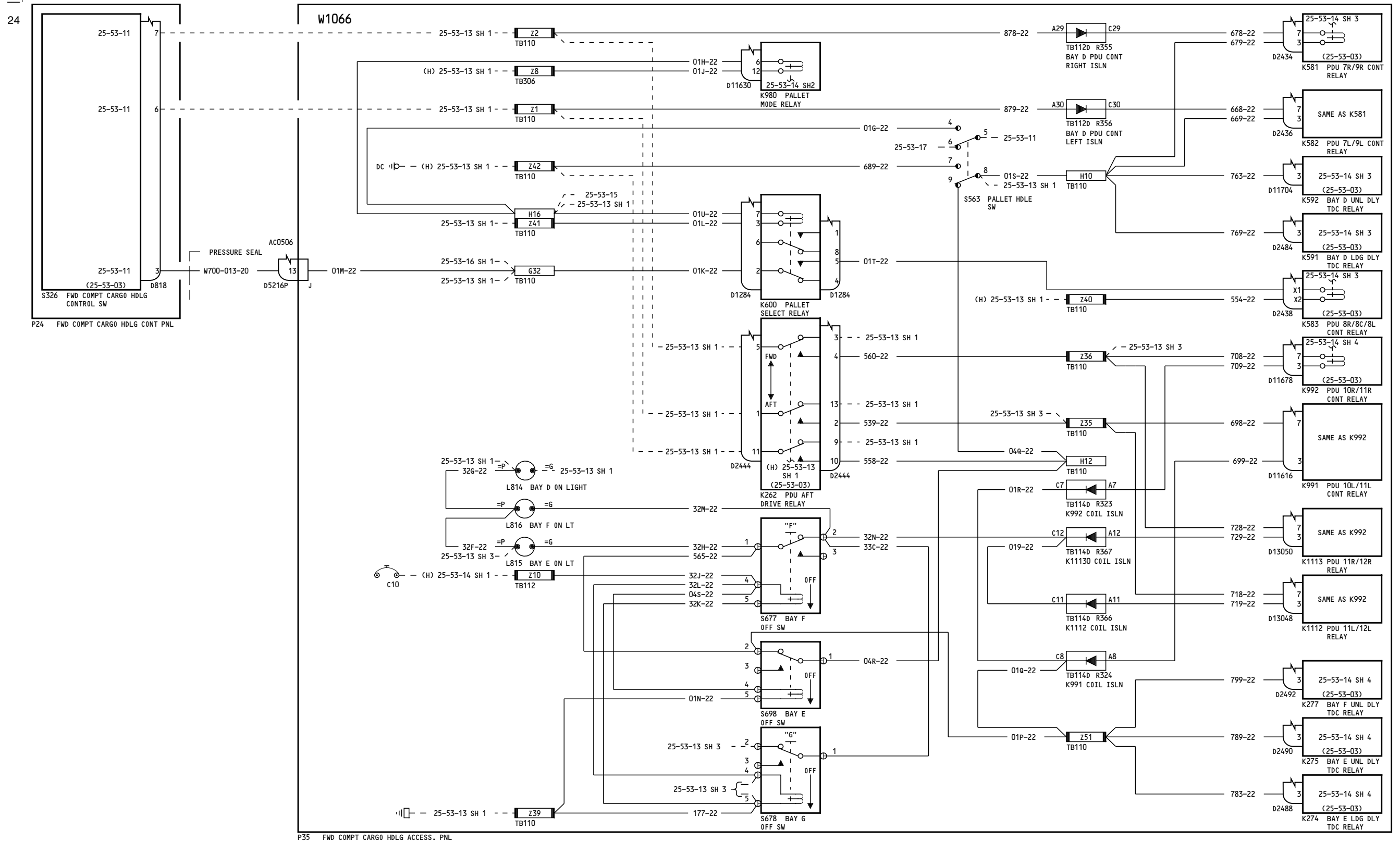

150-199, 275-299

**CARGO HANDLING-
FORWARD LOWER LOBE
FWD/AFT PDU CONTROL**

25-53-13

Page 2
Sheet 2
Jan 21/2005

D280T132

25-53-13

Page 2
Sheet 2
Jan 21/2005

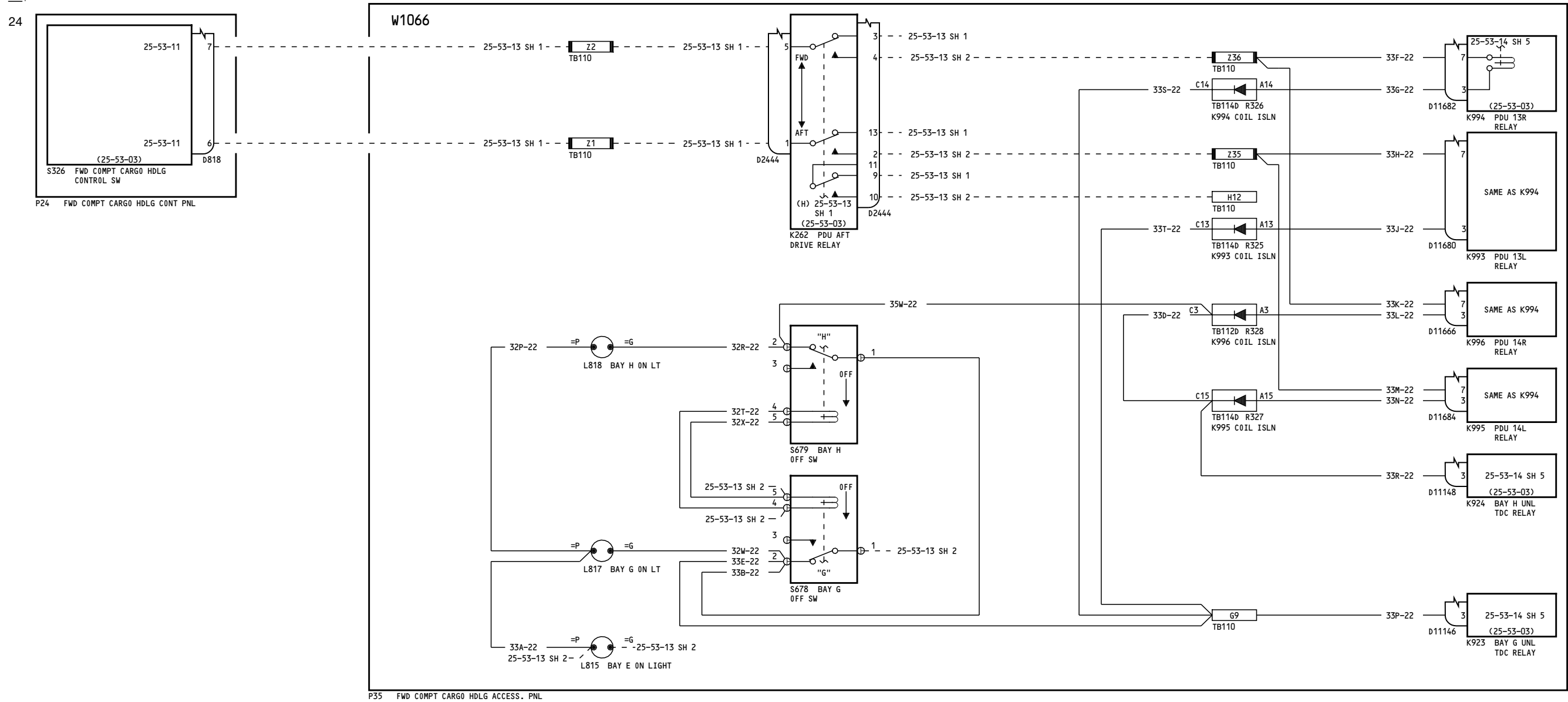

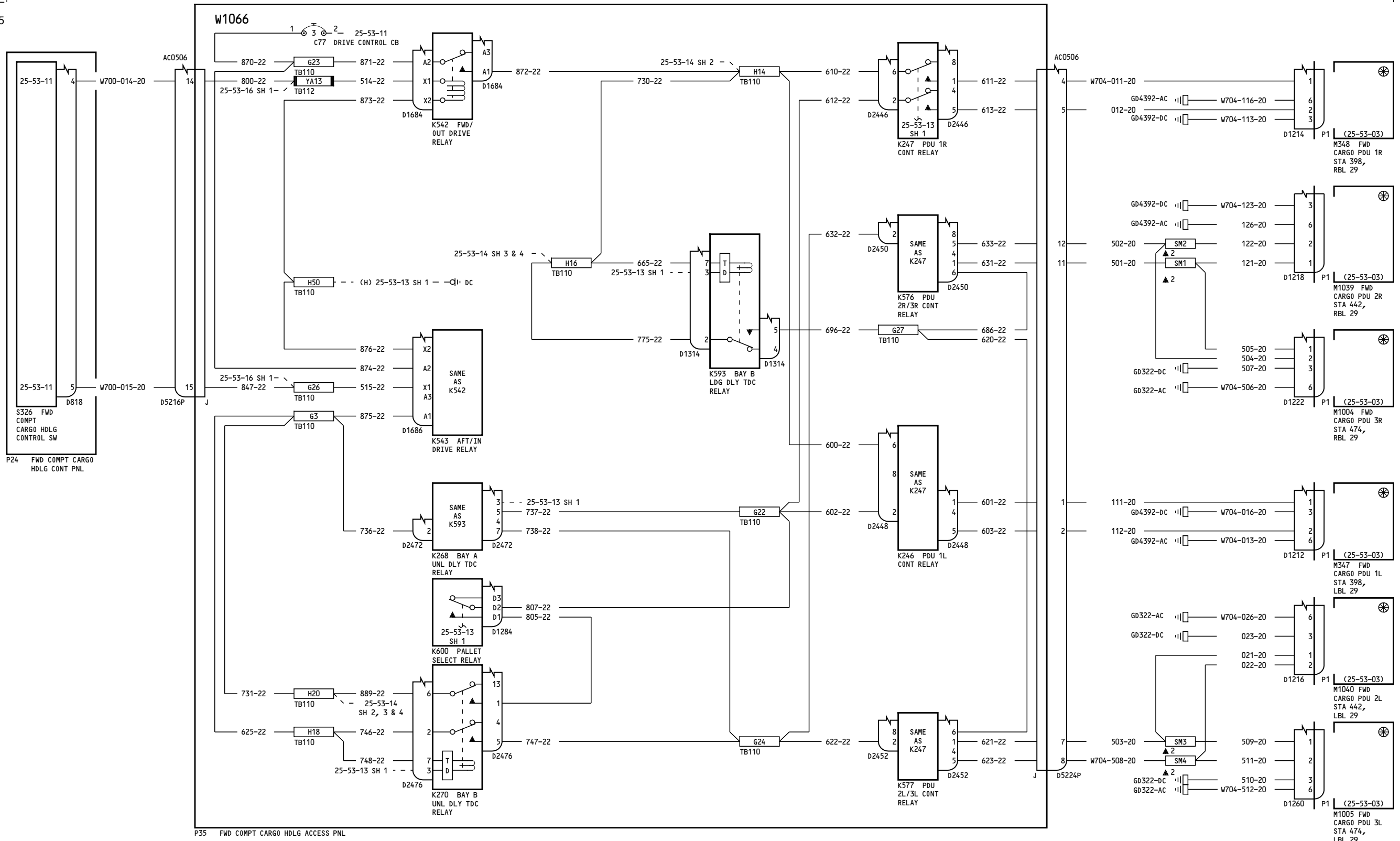

050-099

CARGO HANDLING- FORWARD LOWER LOBE PDU LOAD/UNLOAD CONTROL

25-53-14

Page 1
Sheet 1
Jan 21/2005

D280T132

25-53-14

Page 1
Sheet 1
Jan 21/2005

25

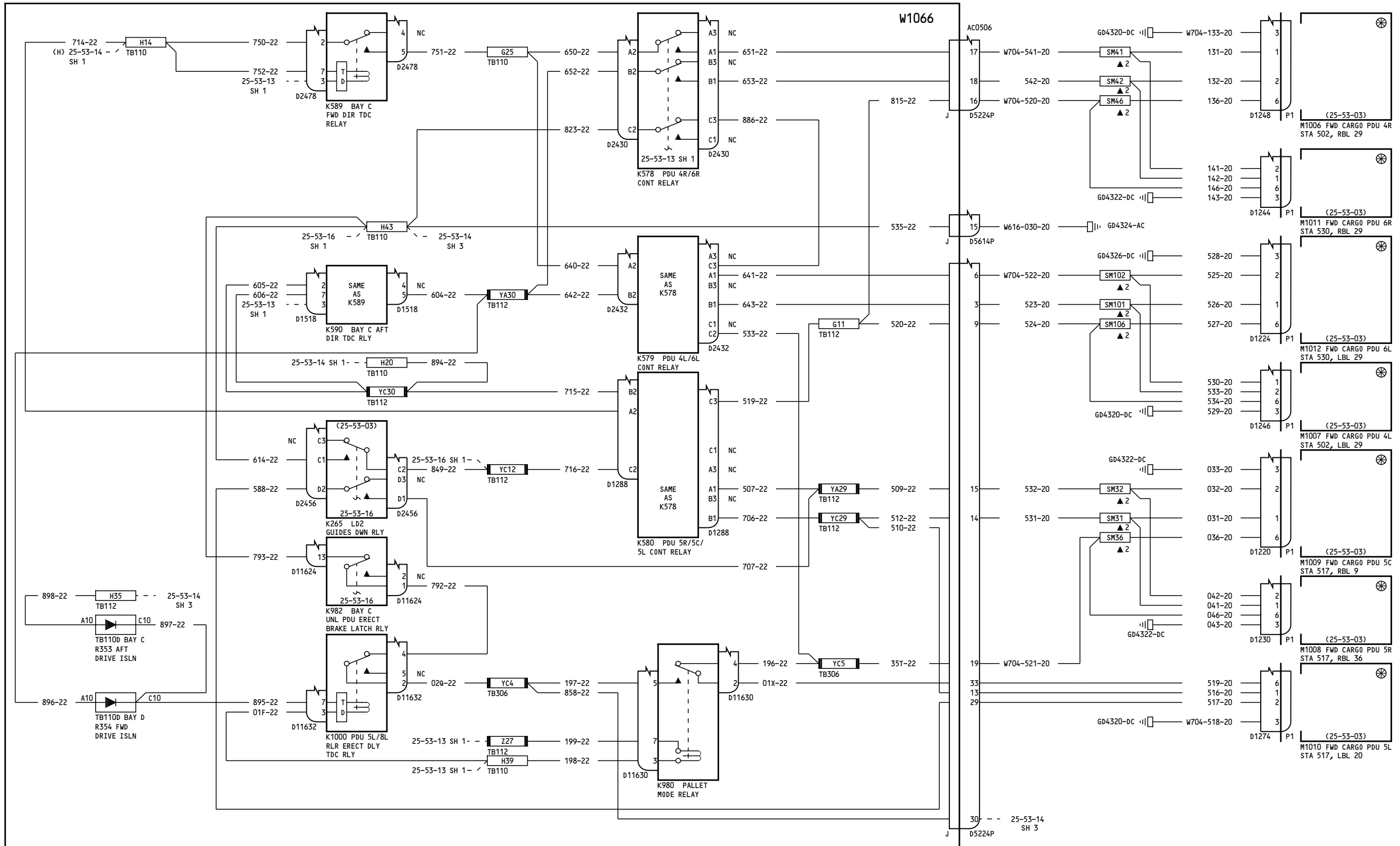

P35 FWD COMPT CARGO HLDG ACCESS PNL

050-099

**CARGO HANDLING-
FORWARD LOWER LOBE PDU
LOAD/UNLOAD CONTROL**

25-53-14

Page 1
Sheet 2
Jan 21/2005

D280T132

25-53-14

Page 1
Sheet 2
Jan 21/2005

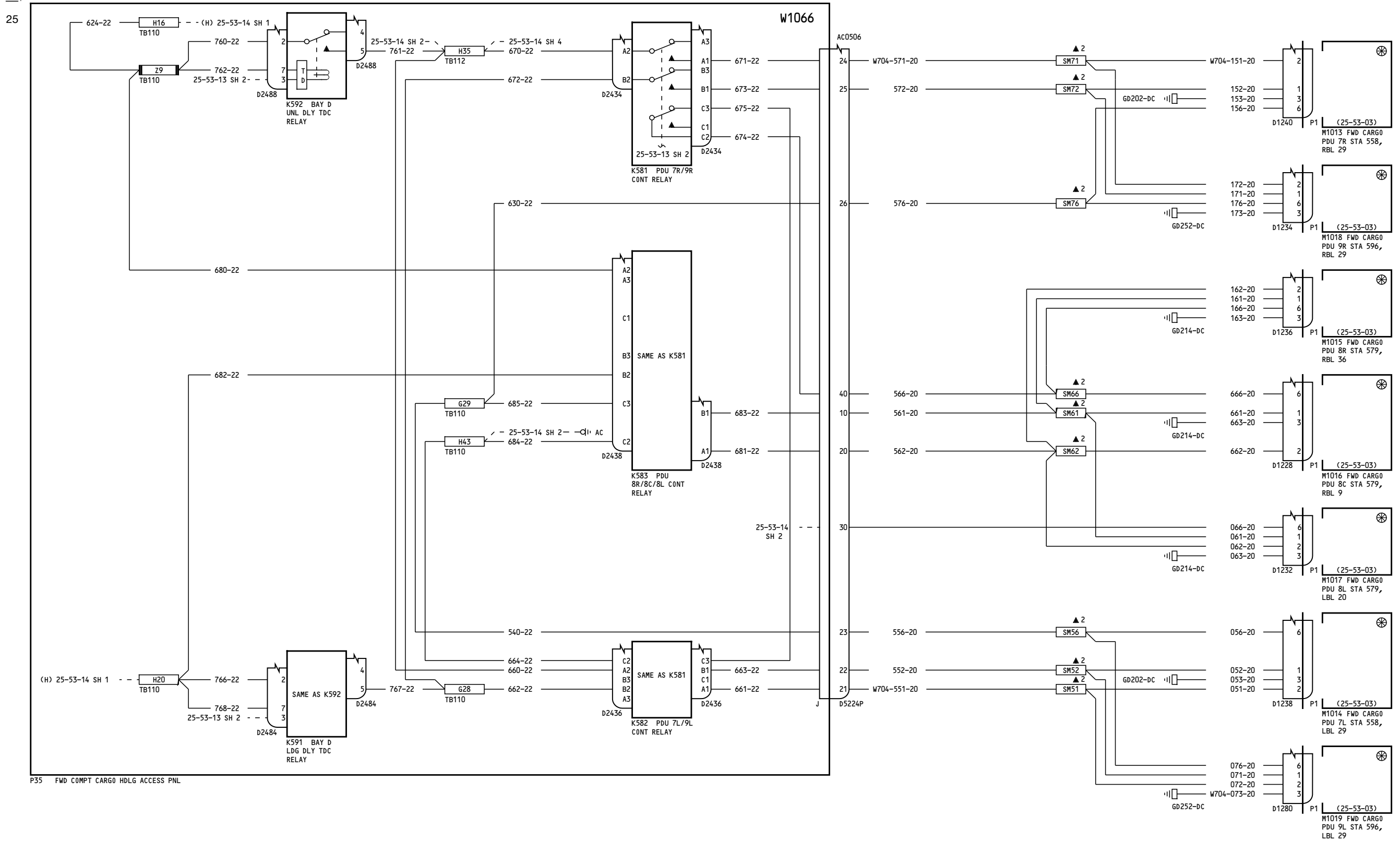

P35 FWD COMPT CARGO HDLG ACCESS PNL

050-099

**CARGO HANDLING-
FORWARD LOWER LOBE PDU
LOAD/UNLOAD CONTROL**

25-53-14

Page 1
Sheet 3
Jan 21/2005

D280T132

25-53-14

Page 1
Sheet 3
Jan 21/2005

25

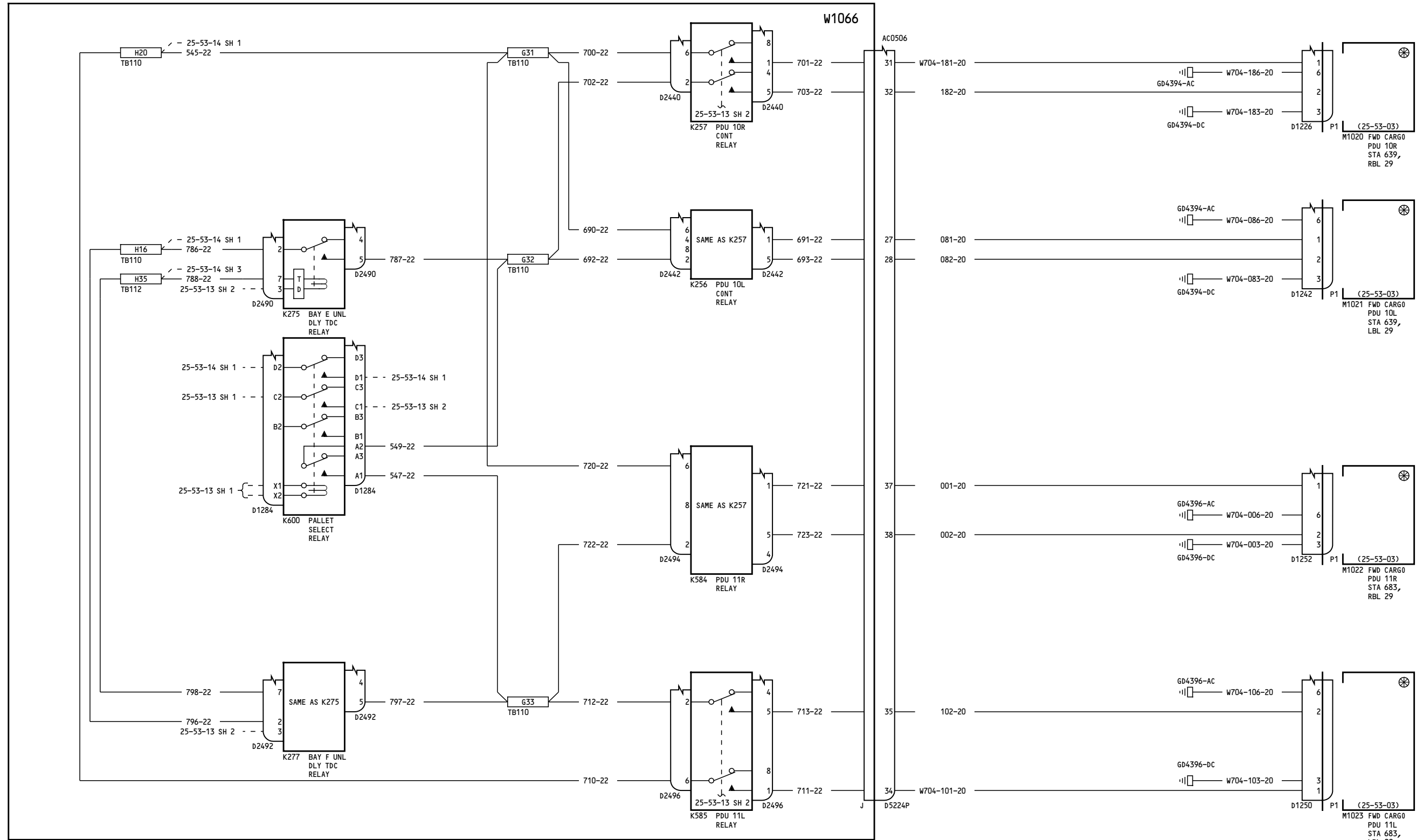

P35 FWD COMPT CARGO HDLG ACCESS PNL

050-099

**CARGO HANDLING-
FORWARD LOWER LOBE PDU
LOAD/UNLOAD CONTROL**

D280T132

25-53-14

Page 1
Sheet 4
Jan 21/2005

25-53-14

Page 1
Sheet 4
Jan 21/2005

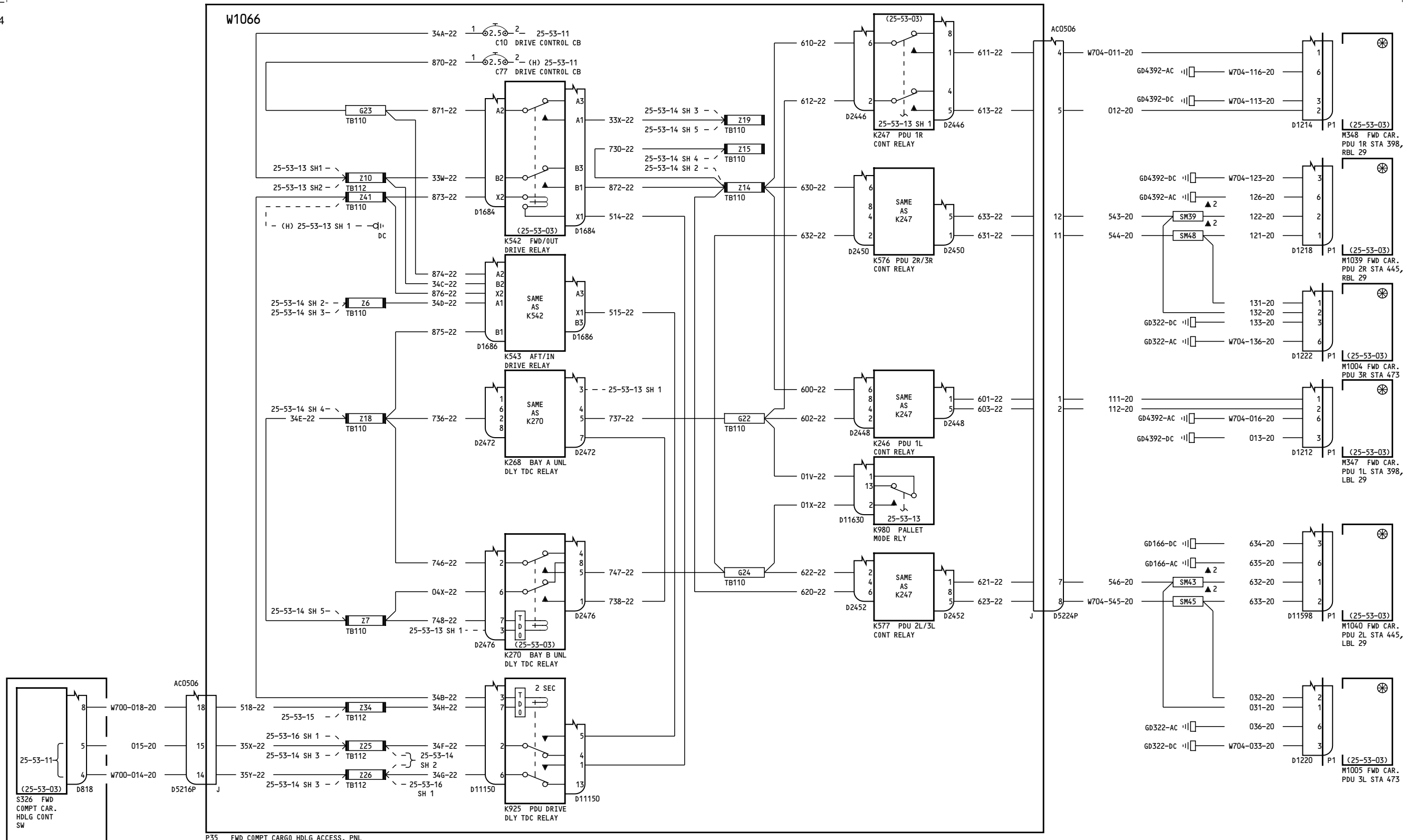

P24 FWD COMPT CARGO HDLG CONT PNL

P35 FWD COMPT CARGO HDLG ACCESS. PNL

150-199, 275-278

**CARGO HANDLING-
FORWARD LOWER LOBE PDU
LOAD/UNLOAD CONTROL**

D280T132

25-53-14

Page 2
Sheet 1
Jan 21/2005

25-53-14

Page 2
Sheet 1
Jan 21/2005

14

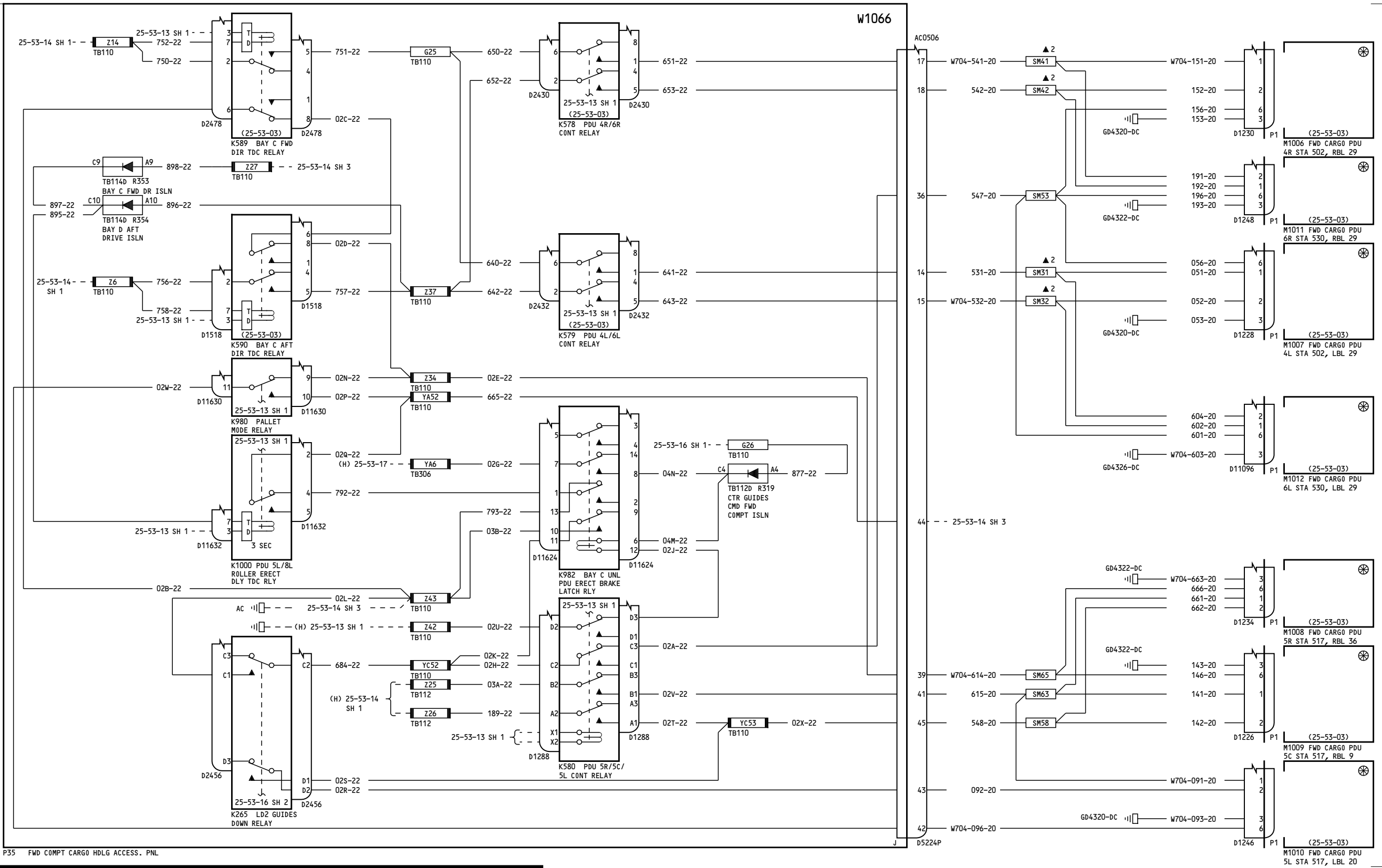

P35 FWD COMPT CARGO HDLG ACCESS. PNL

150-199, 275-278

CARGO HANDLING- FORWARD LOWER LOBE PDU LOAD/UNLOAD CONTROL

D280T132

25-53-14

Page 2
Sheet 2
Jan 21/2005

25-53-14

Page 2
Sheet 2
Jan 21/2005

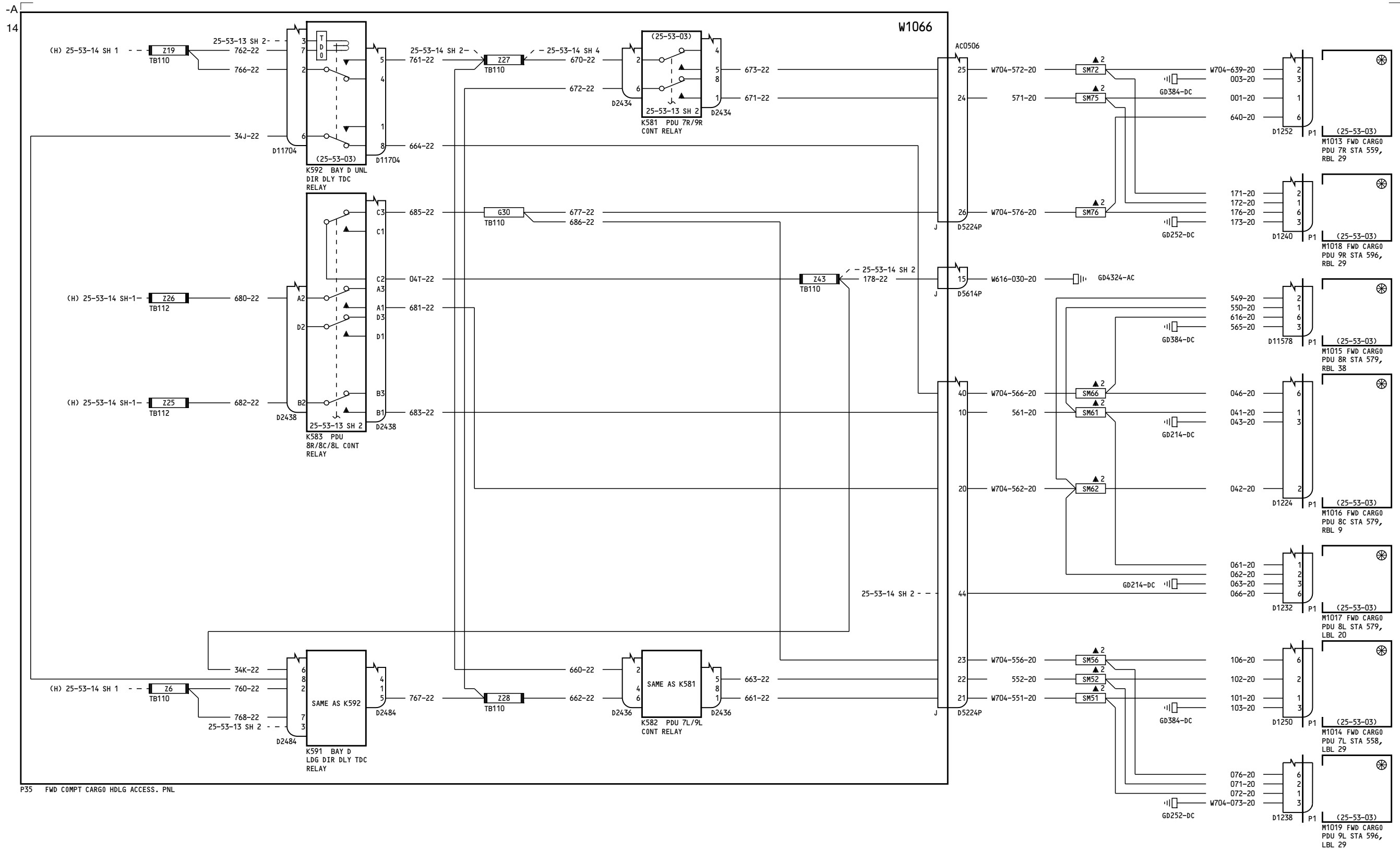

P35 FWD COMPT CARGO HDLG ACCESS. PNL

150-199, 275-278

**CARGO HANDLING-
FORWARD LOWER LOBE PDU
LOAD/UNLOAD CONTROL**

D280T132

25-53-14

Page 2
Sheet 3
Jan 21/2005

25-53-14

Page 2
Sheet 3
Jan 21/2005

-A
14

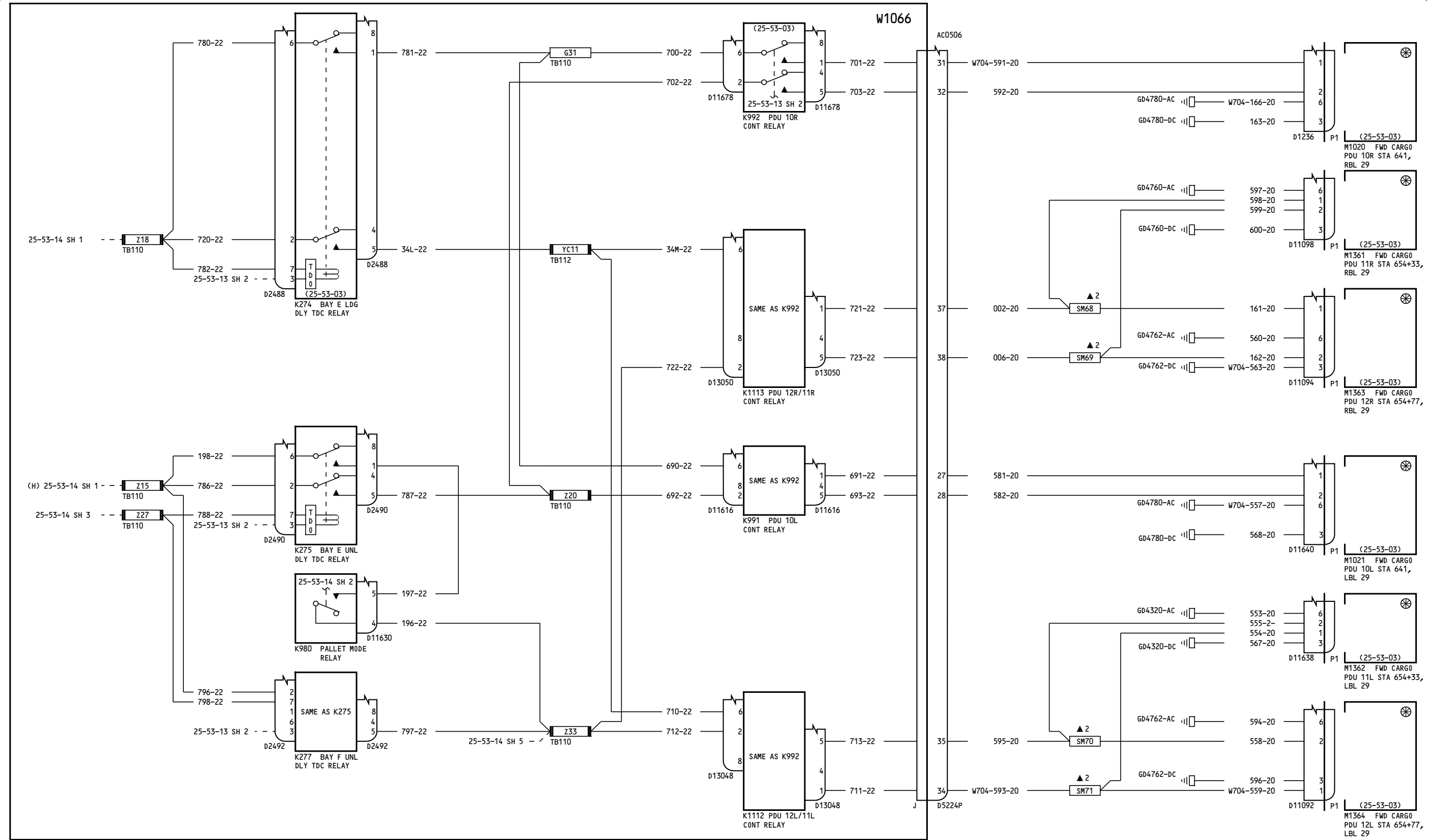

P35 FWD COMPT CARGO HDLG ACCESS. PNL

150-199, 275-278

**CARGO HANDLING-
FORWARD LOWER LOBE PDU
LOAD/UNLOAD CONTROL**

D280T132

25-53-14

Page 2
Sheet 4
Jan 21/2005

25-53-14

Page 2
Sheet 4
Jan 21/2005

14

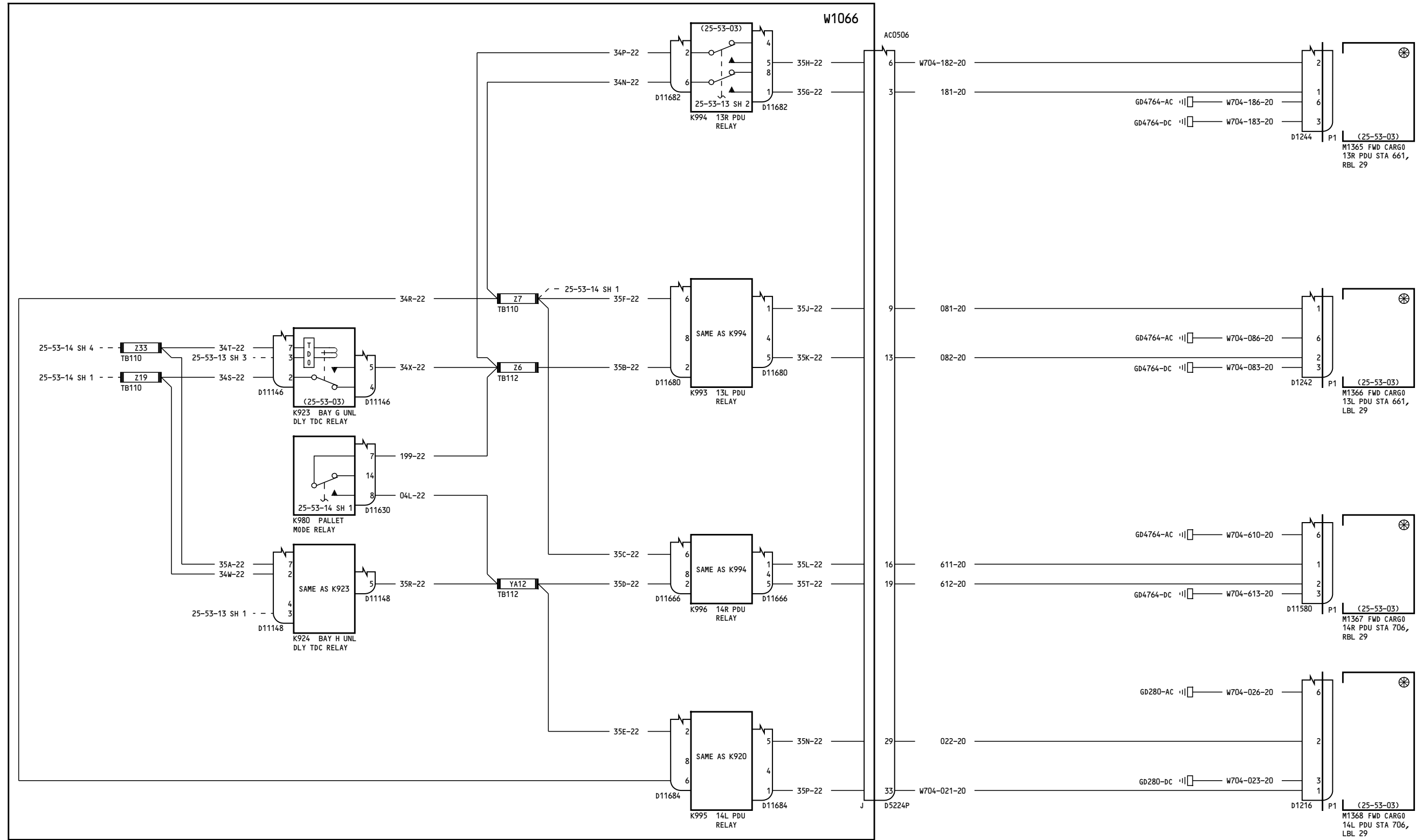

P35 FWD COMPT CARGO HDLG ACCESS. PNL

150-199, 275-278

**CARGO HANDLING-
FORWARD LOWER LOBE PDU
LOAD/UNLOAD CONTROL**

D280T132

25-53-14

Page 2
Sheet 5
Jan 21/2005

25-53-14

Page 2
Sheet 5
Jan 21/2005

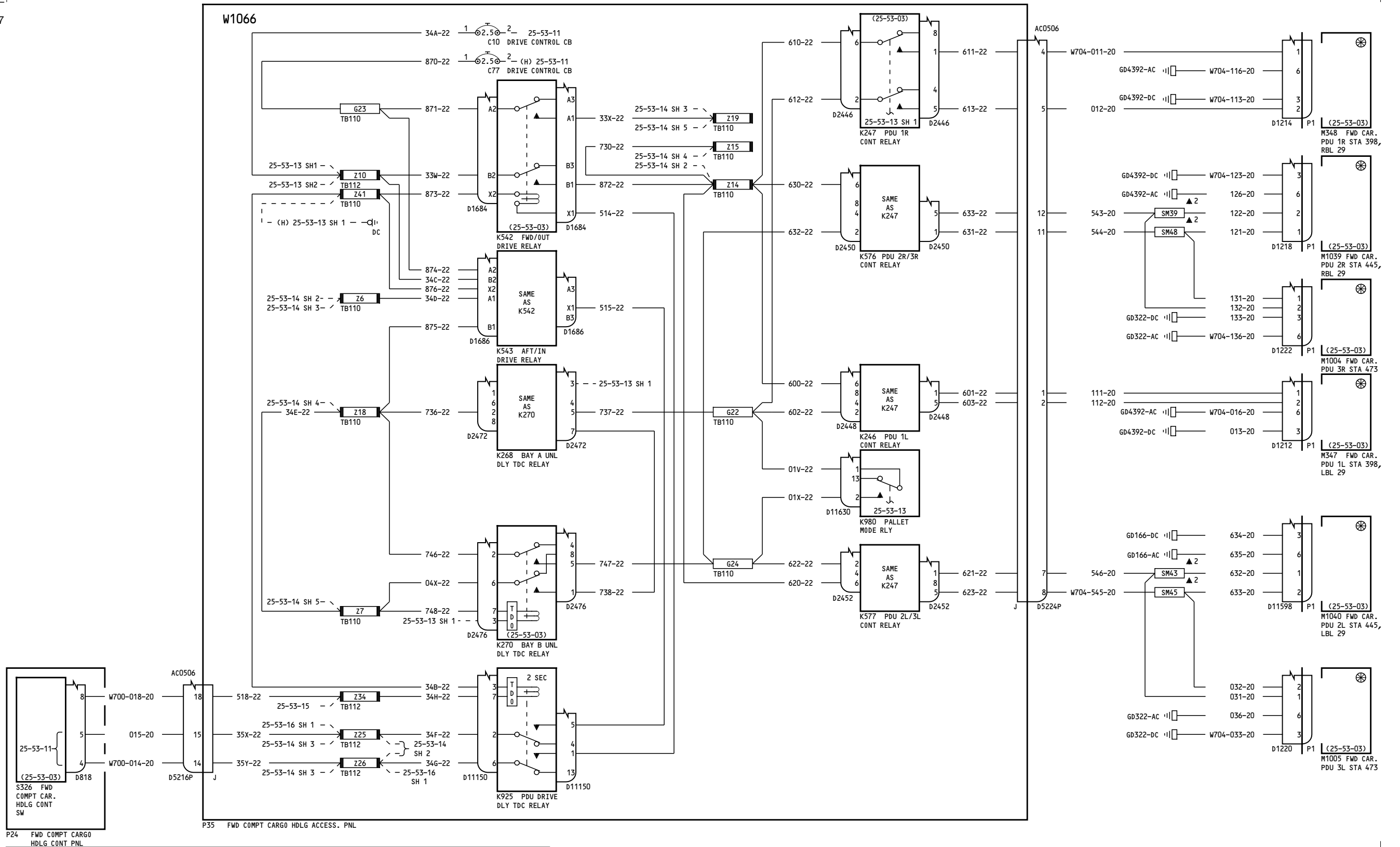

P24 FWD COMPT CARGO HDLG CONT PNL

P35 FWD COMPT CARGO HDLG ACCESS. PNL

280-299

**CARGO HANDLING-
FORWARD LOWER LOBE PDU
LOAD/UNLOAD CONTROL**

D280T132

25-53-14

Page 3
Sheet 1
Jan 21/2005

25-53-14

Page 3
Sheet 1
Jan 21/2005

27

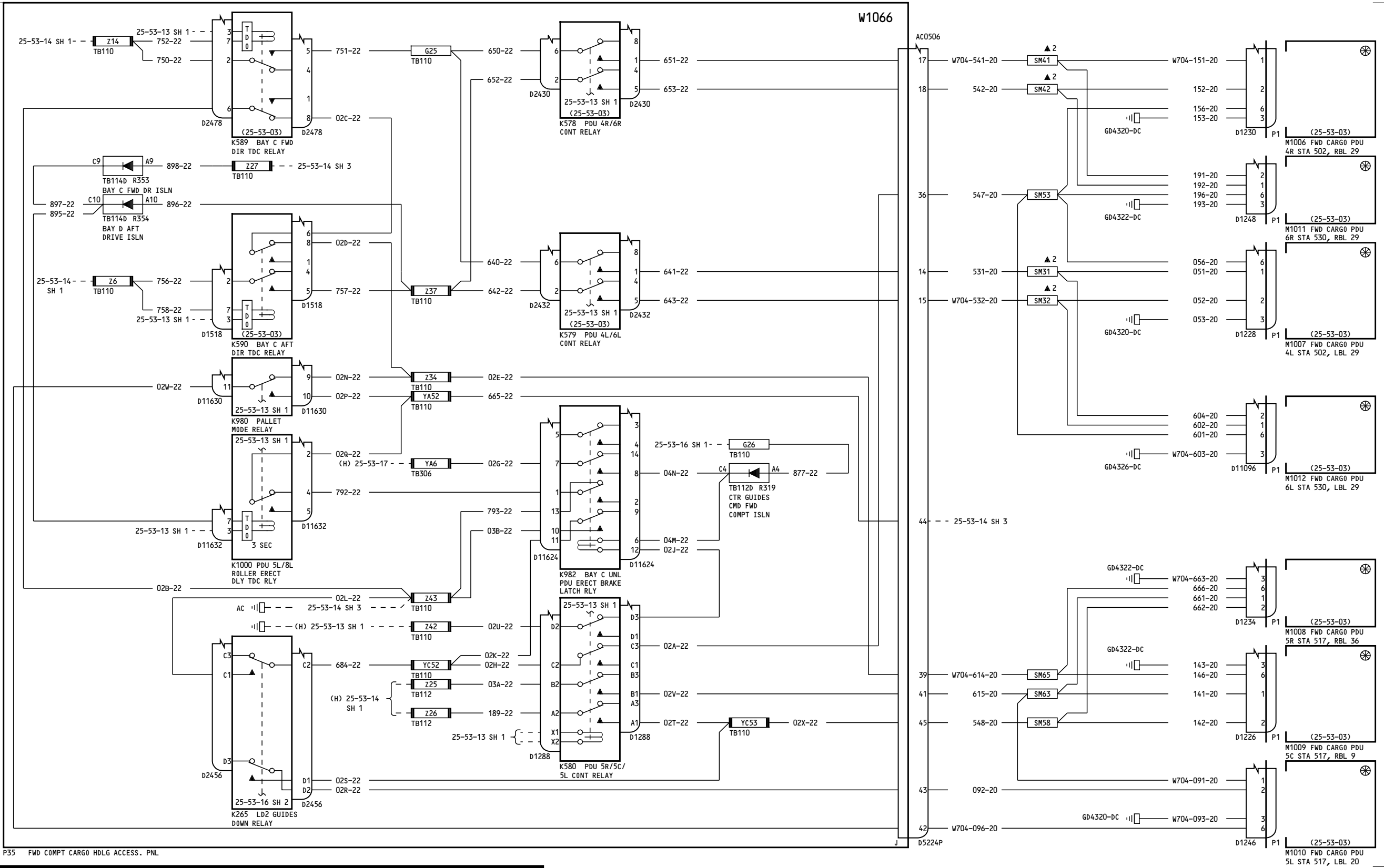

P35 FWD COMPT CARGO HDLG ACCESS. PNL

280-299

**CARGO HANDLING-
FORWARD LOWER LOBE PDU
LOAD/UNLOAD CONTROL**

D280T132

25-53-14

Page 3
Sheet 2
Jan 21/2005

25-53-14

Page 3
Sheet 2
Jan 21/2005

27

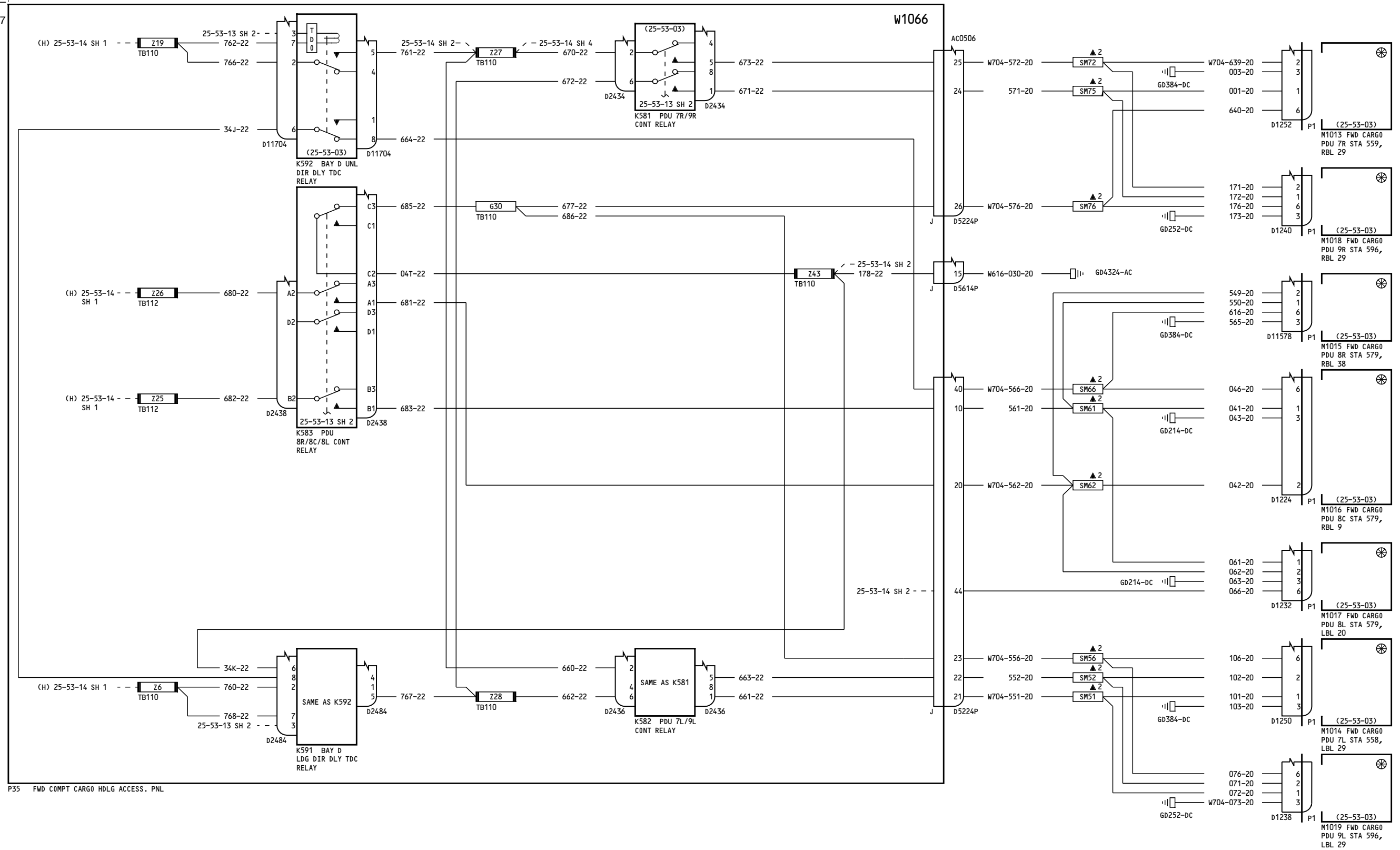

P35 FWD COMPT CARGO HDLG ACCESS. PNL

280-299

**CARGO HANDLING-
FORWARD LOWER LOBE PDU
LOAD/UNLOAD CONTROL**

D280T132

25-53-14

Page 3
Sheet 3
Jan 21/2005

25-53-14

Page 3
Sheet 3
Jan 21/2005

27

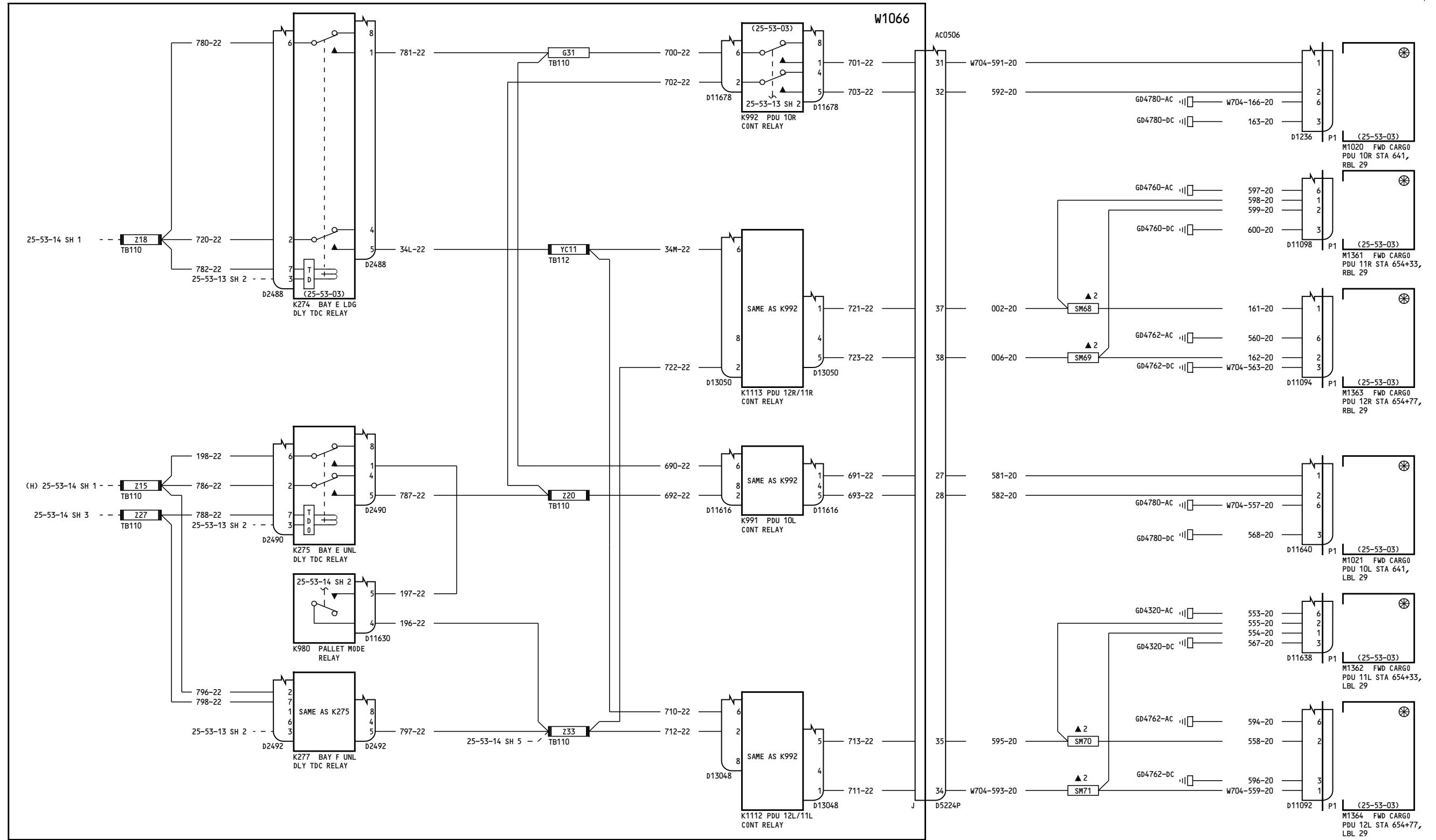

P35 FWD COMPT CARGO HDLG ACCESS. PNL

280-299

**CARGO HANDLING-
FORWARD LOWER LOBE PDU
LOAD/UNLOAD CONTROL**

25-53-14

Page 3
Sheet 4
Jan 21/2005

D280T132

25-53-14

Page 3
Sheet 4
Jan 21/2005

27

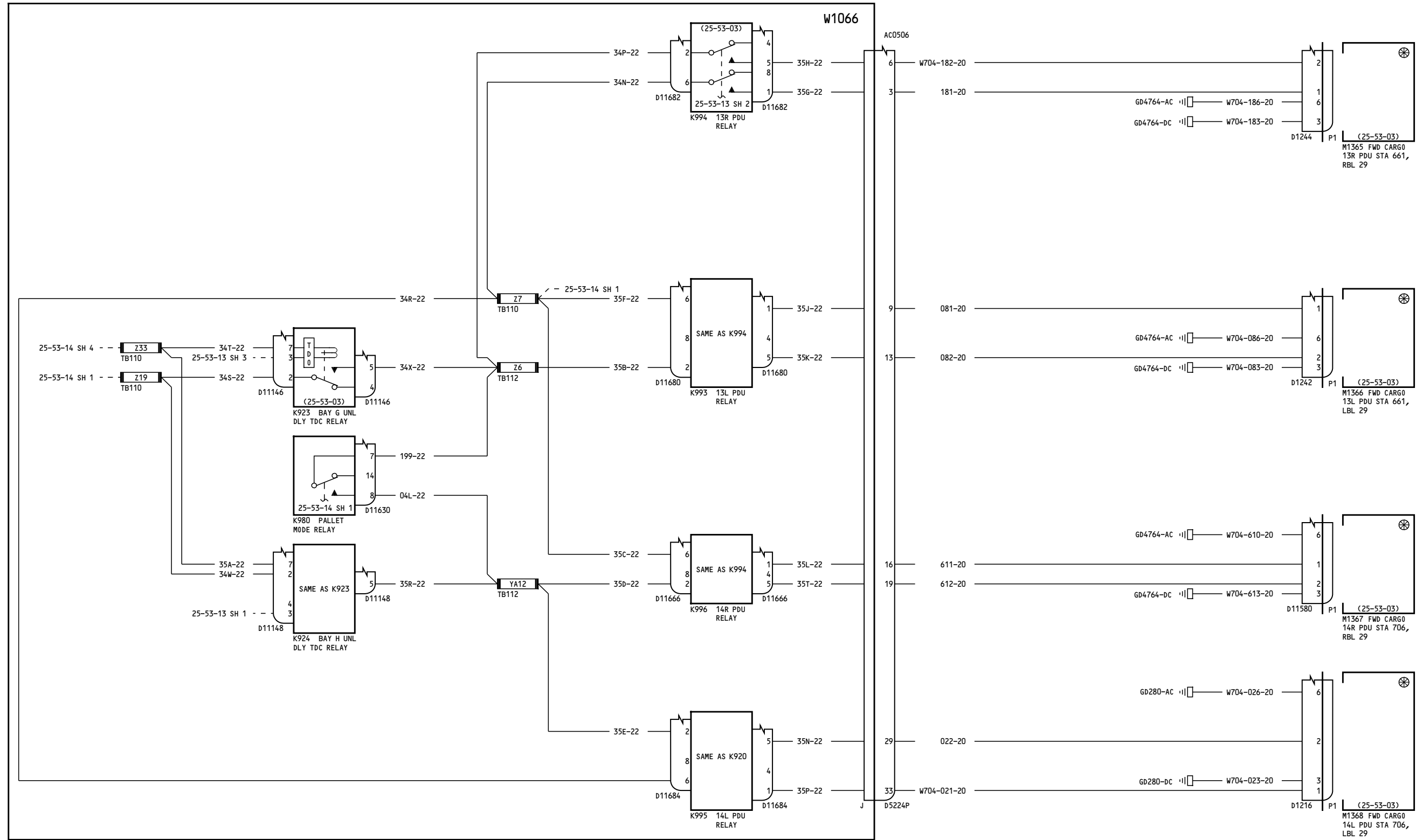

P35 FWD COMPT CARGO HDLG ACCESS. PNL

280-299

**CARGO HANDLING-
FORWARD LOWER LOBE PDU
LOAD/UNLOAD CONTROL**

D280T132

25-53-14

Page 3
Sheet 5
Jan 21/2005

25-53-14

Page 3
Sheet 5
Jan 21/2005

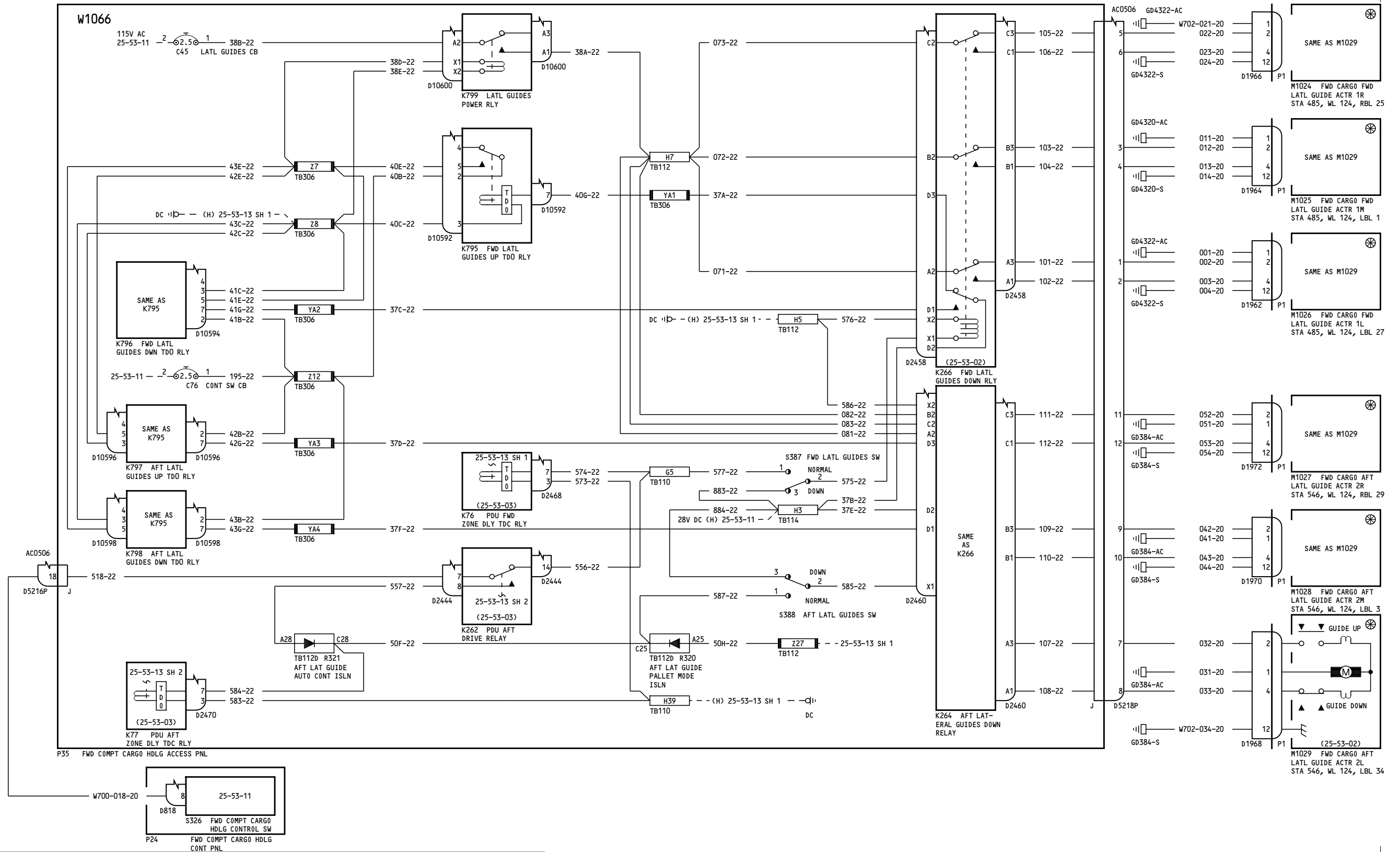

050-099

**CARGO HANDLING-
FORWARD LOWER LOBE
LATERAL GUIDES**

25-53-15

Page 1

Jan 21/2005

D280T132

25-53-15

Page 1

Jan 21/2005

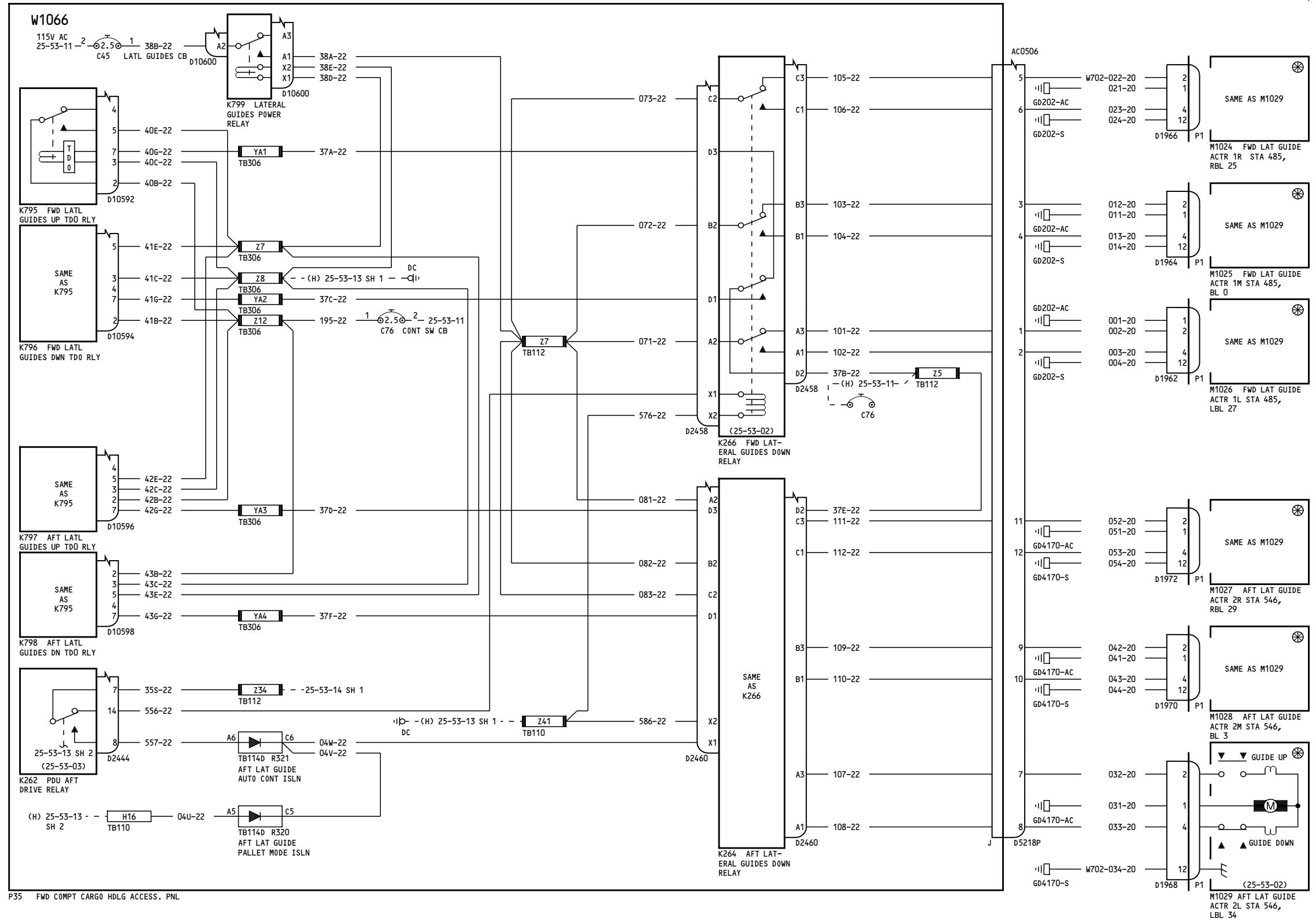

150-199, 275-278

CARGO HANDLING-FORWARD LOWER LOBE LATERAL GUIDES

25-53-15

Page 2

Jan 21/2005

D280T132

25-53-15

Page 2

Jan 21/2005

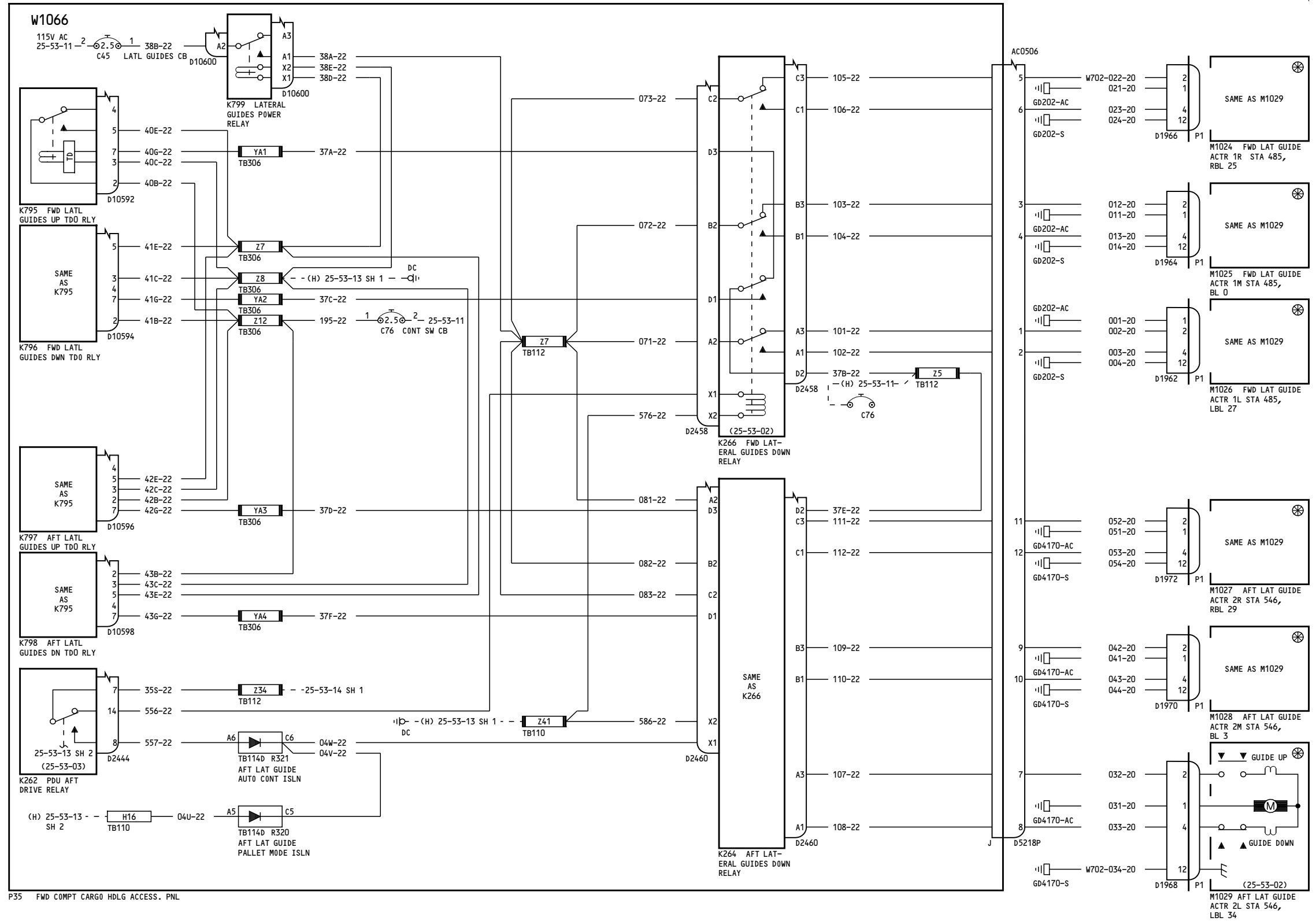

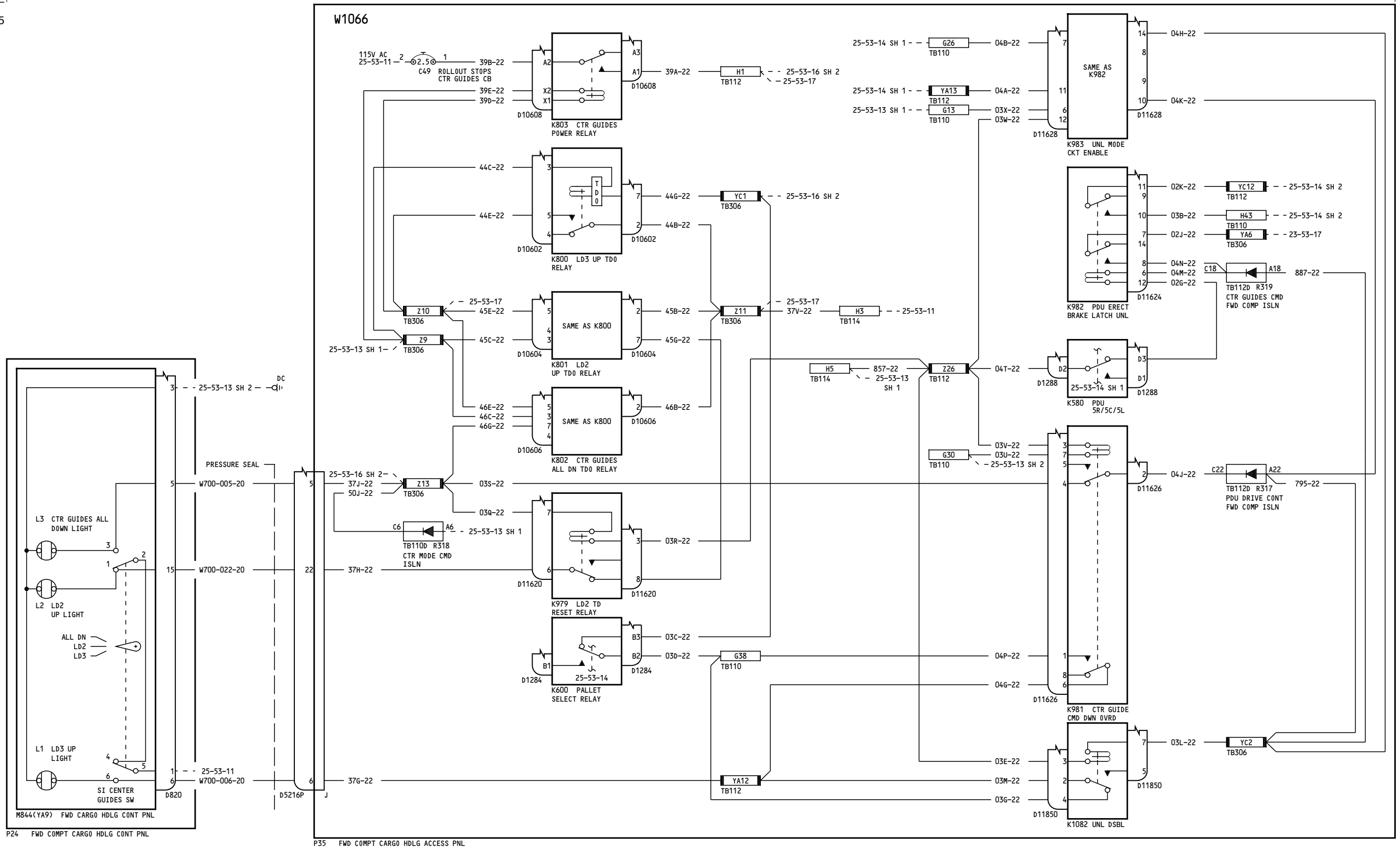

050-099

**CARGO HANDLING-
FORWARD LOWER LOBE
CENTER GUIDES**

25-53-16

Page 1
Sheet 1
Jan 21/2005

D280T132

25-53-16

Page 1
Sheet 1
Jan 21/2005

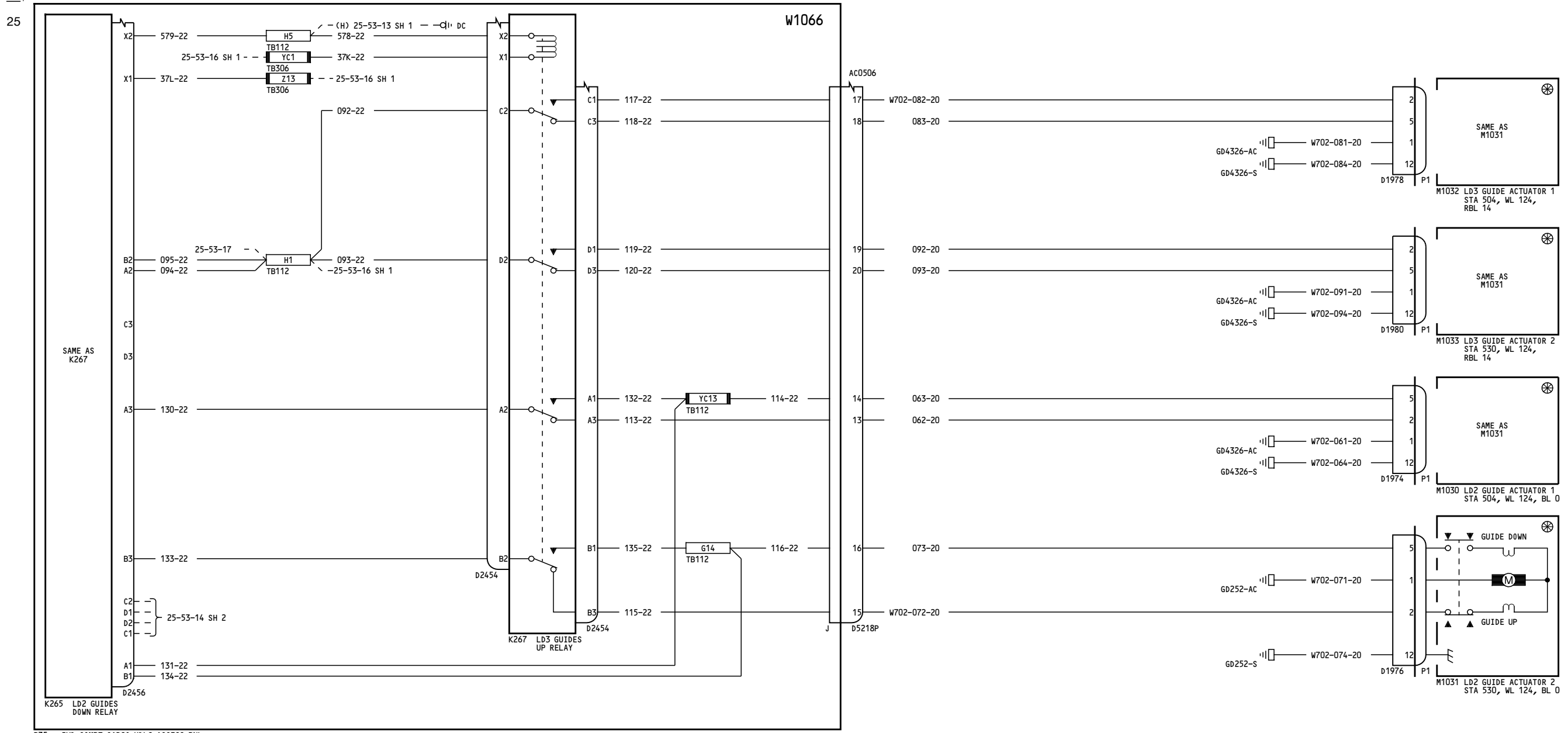

P35 FWD COMPT CARGO HDLG ACCESS PNL

050-099

**CARGO HANDLING-
FORWARD LOWER LOBE
CENTER GUIDES**

25-53-16

Page 1
Sheet 2
Jan 21/2005

D280T132

25-53-16

Page 1
Sheet 2
Jan 21/2005

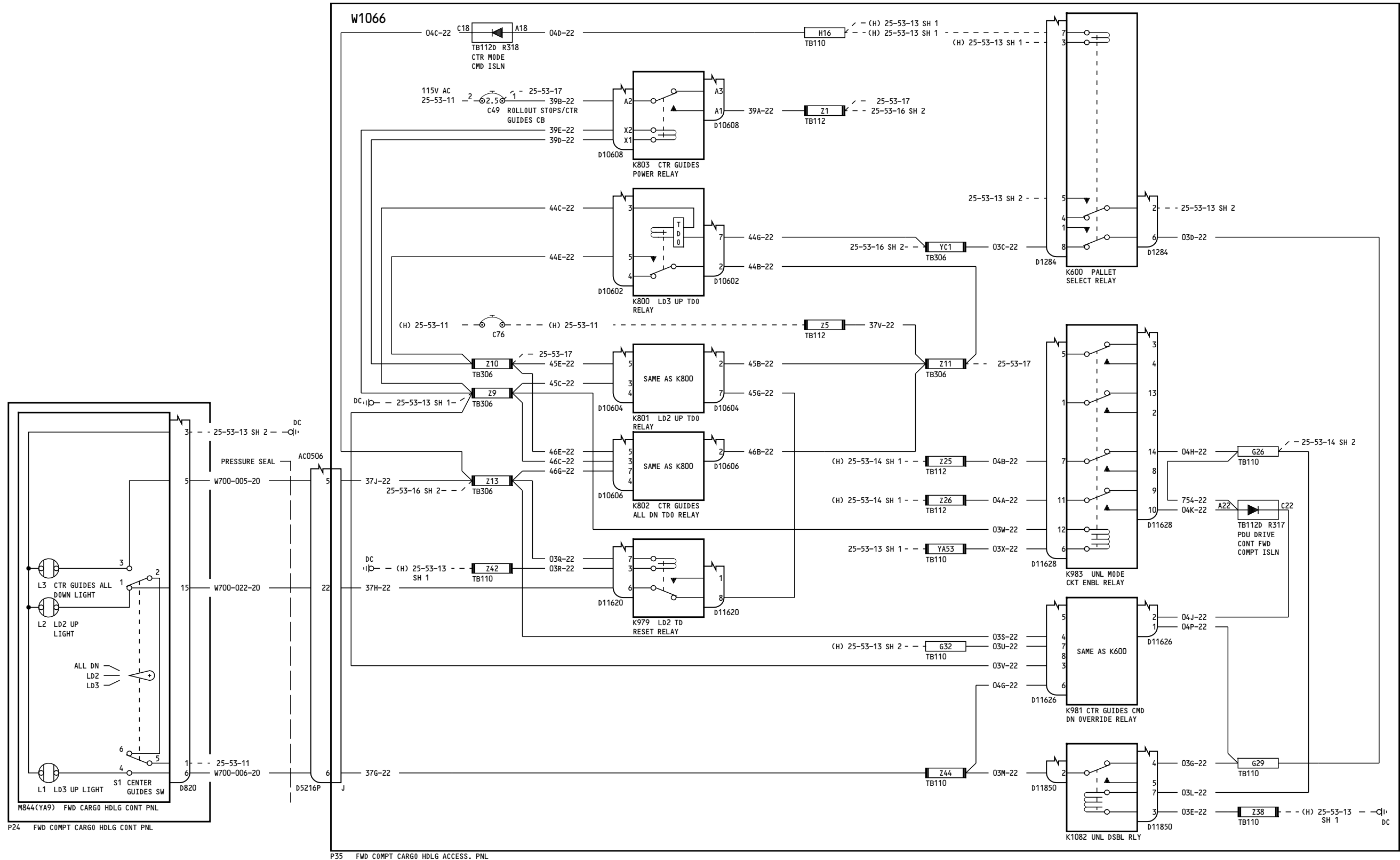

150-199, 275-278

**CARGO HANDLING-
FORWARD LOWER LOBE
CENTER GUIDES**

D280T132

25-53-16

Page 2
Sheet 1
Jan 21/2005

25-53-16

Page 2
Sheet 1
Jan 21/2005

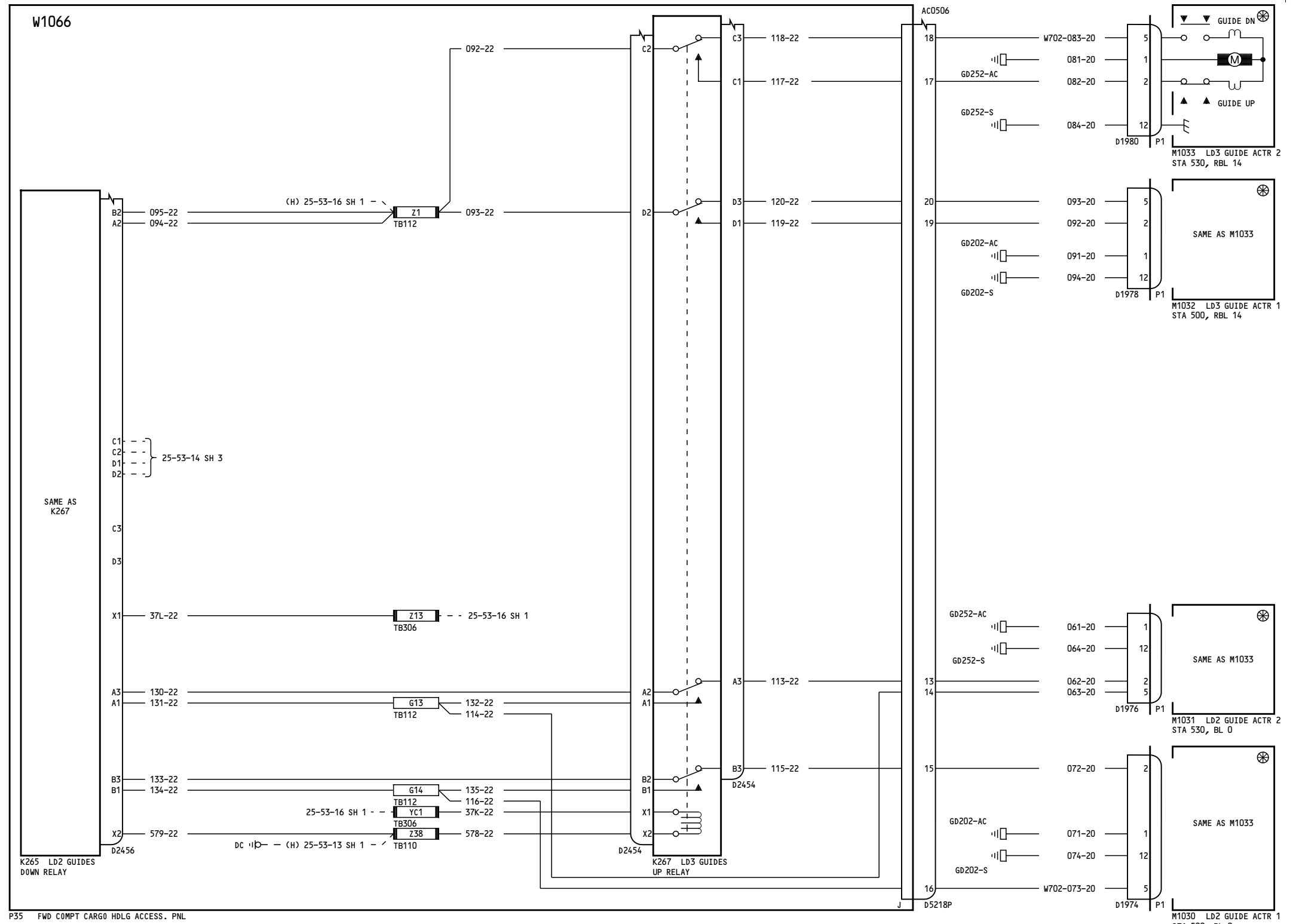

150-199, 275-278

**CARGO HANDLING-
FORWARD LOWER LOBE
CENTER GUIDES**

25-53-16

Page 2
Sheet 2
Jan 21/2005

D280T132

25-53-16

Page 2
Sheet 2
Jan 21/2005

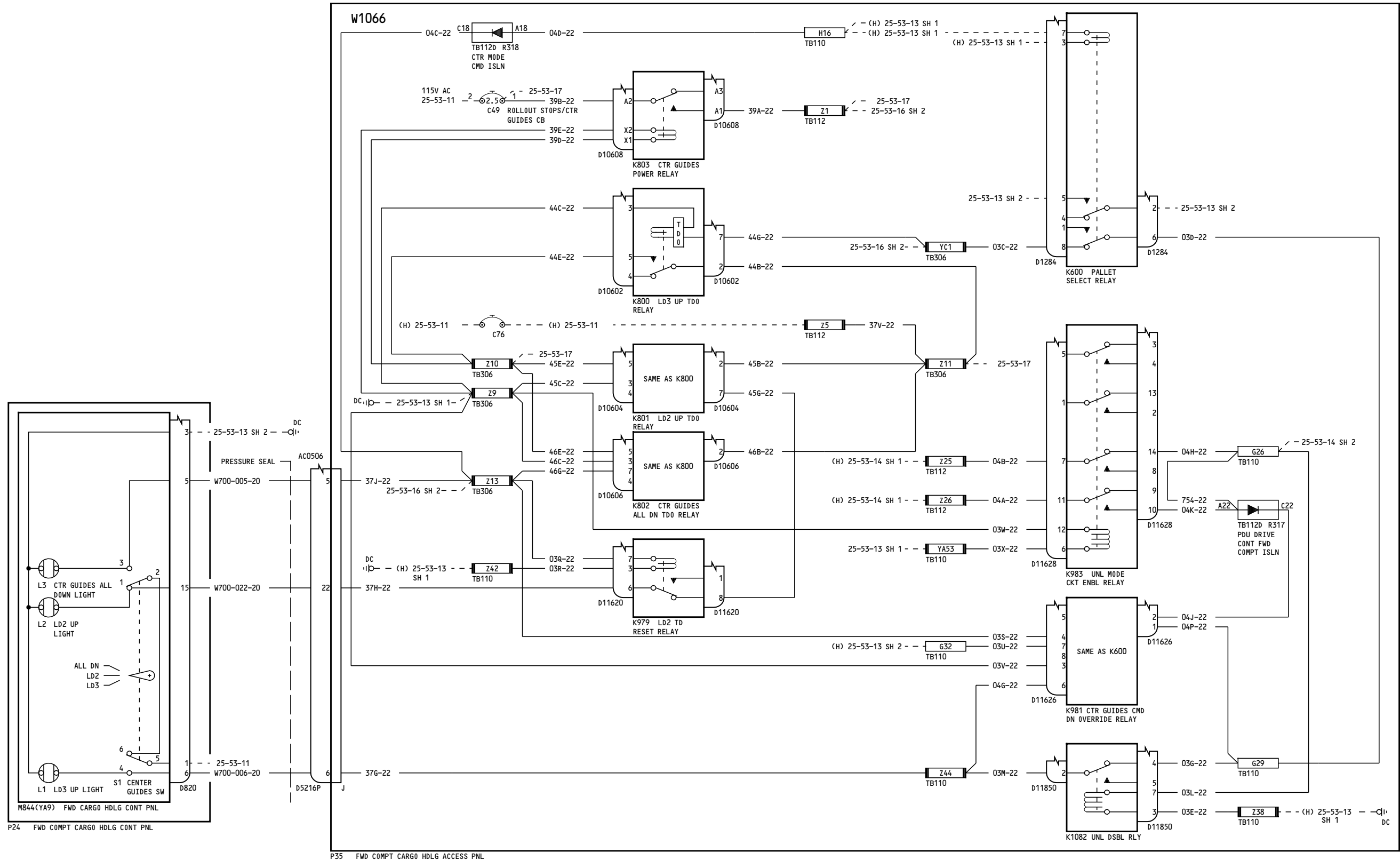

280-299

CARGO HANDLING-FORWARD LOWER LOBE CENTER GUIDES

D280T132

25-53-16

Page 3
Sheet 1
Jan 21/2005

25-53-16

Page 3
Sheet 1
Jan 21/2005

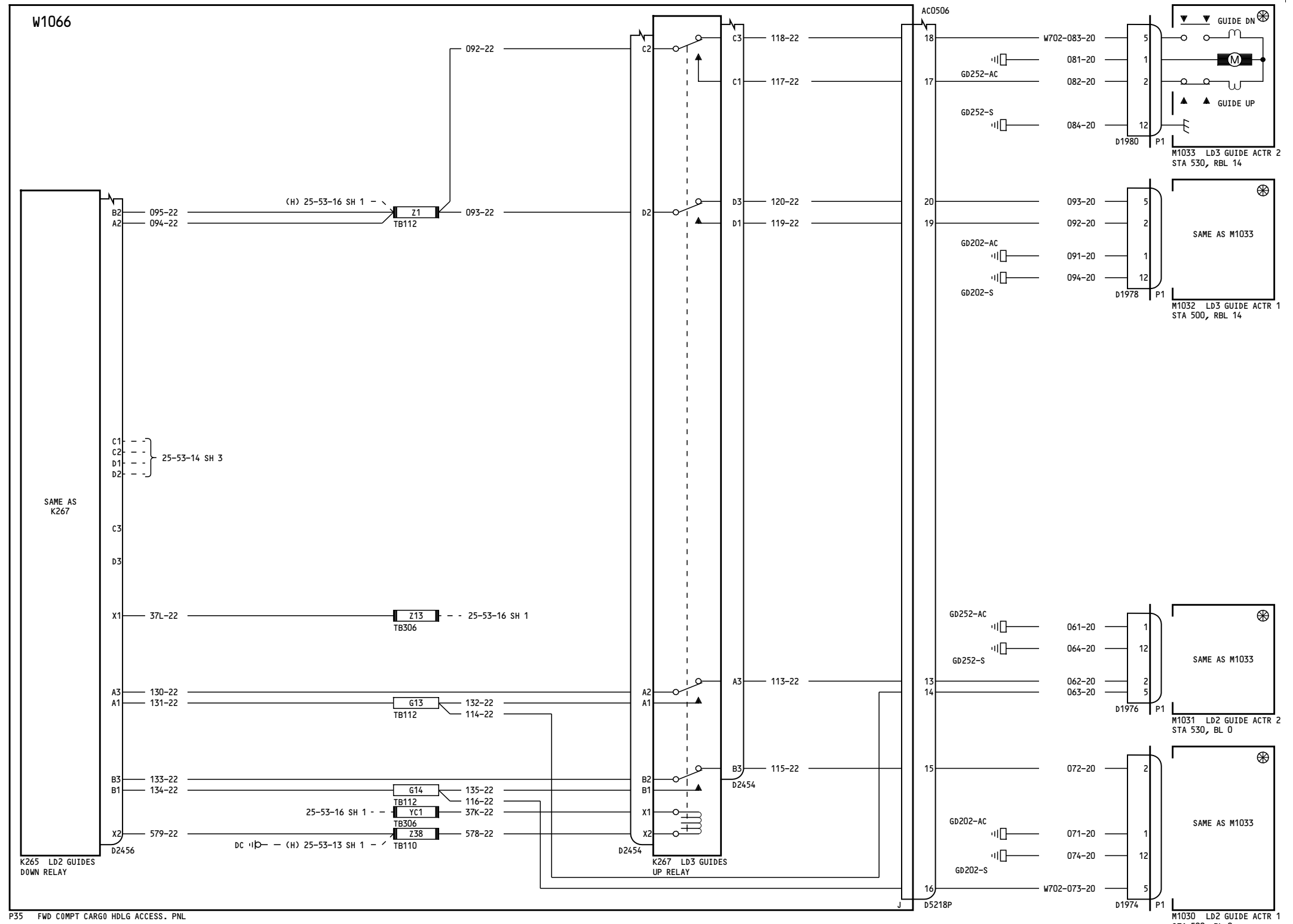

14

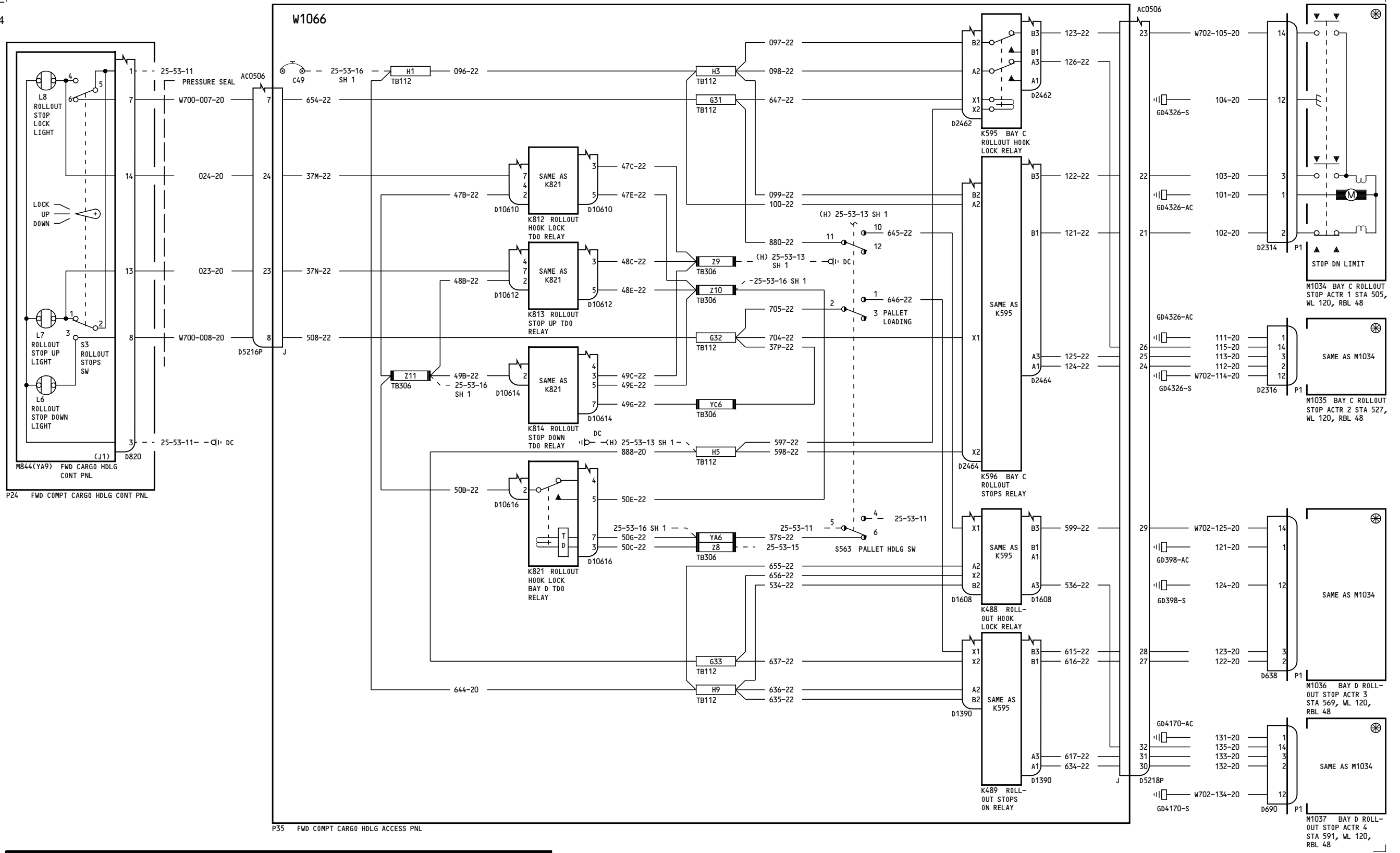

050-099

CARGO HANDLING-FORWARD LOWER LOBE ROLLOUT STOPS

25-53-17

Page 1

D280T132

Jan 21/2005

25-53-17

Page 1

Jan 21/2005

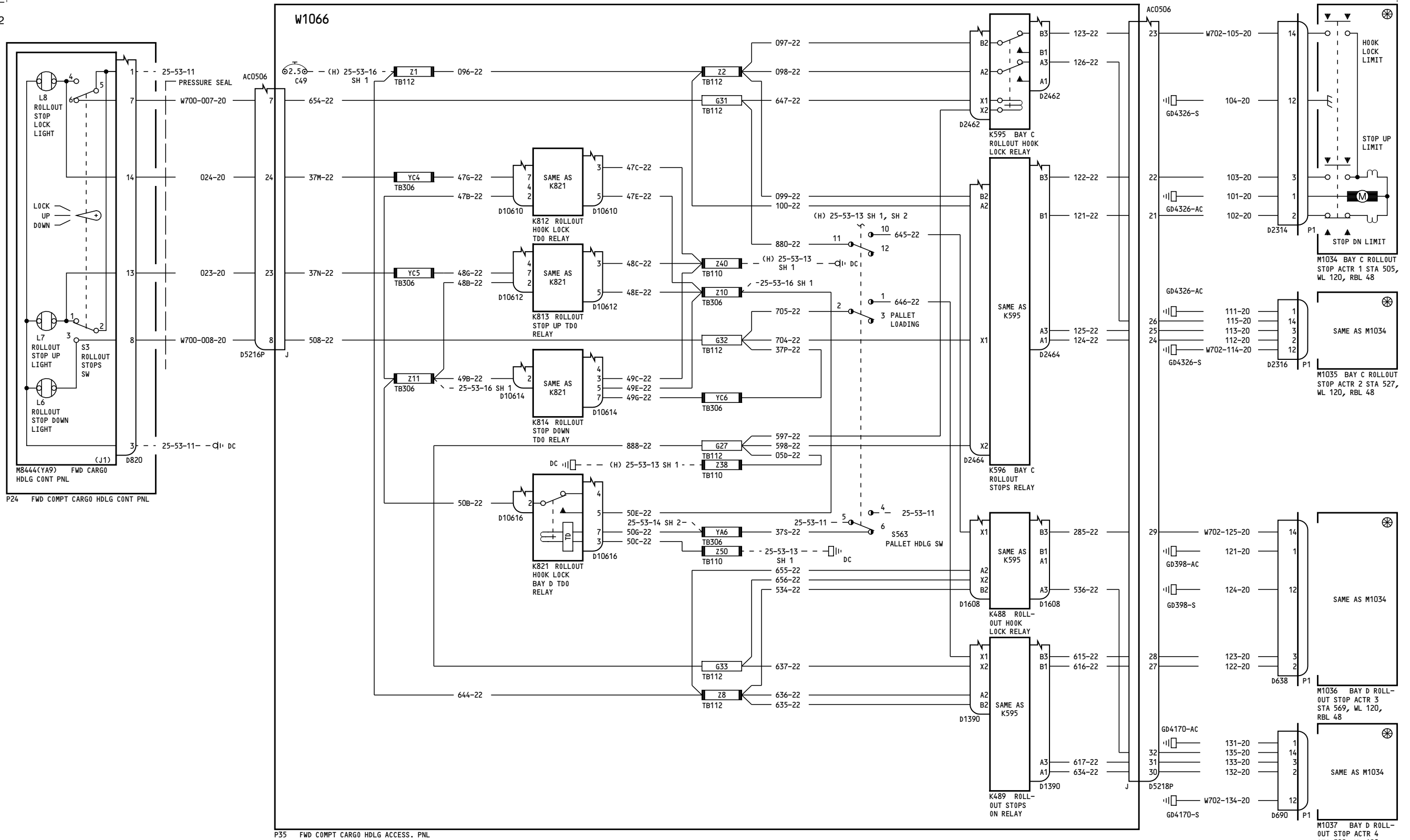

150-199

CARGO HANDLING-FORWARD LOWER LOBE ROLLOUT STOPS

25-53-17

Page 2

D280T132

Jan 21/2005

25-53-17

Page 2

Jan 21/2005

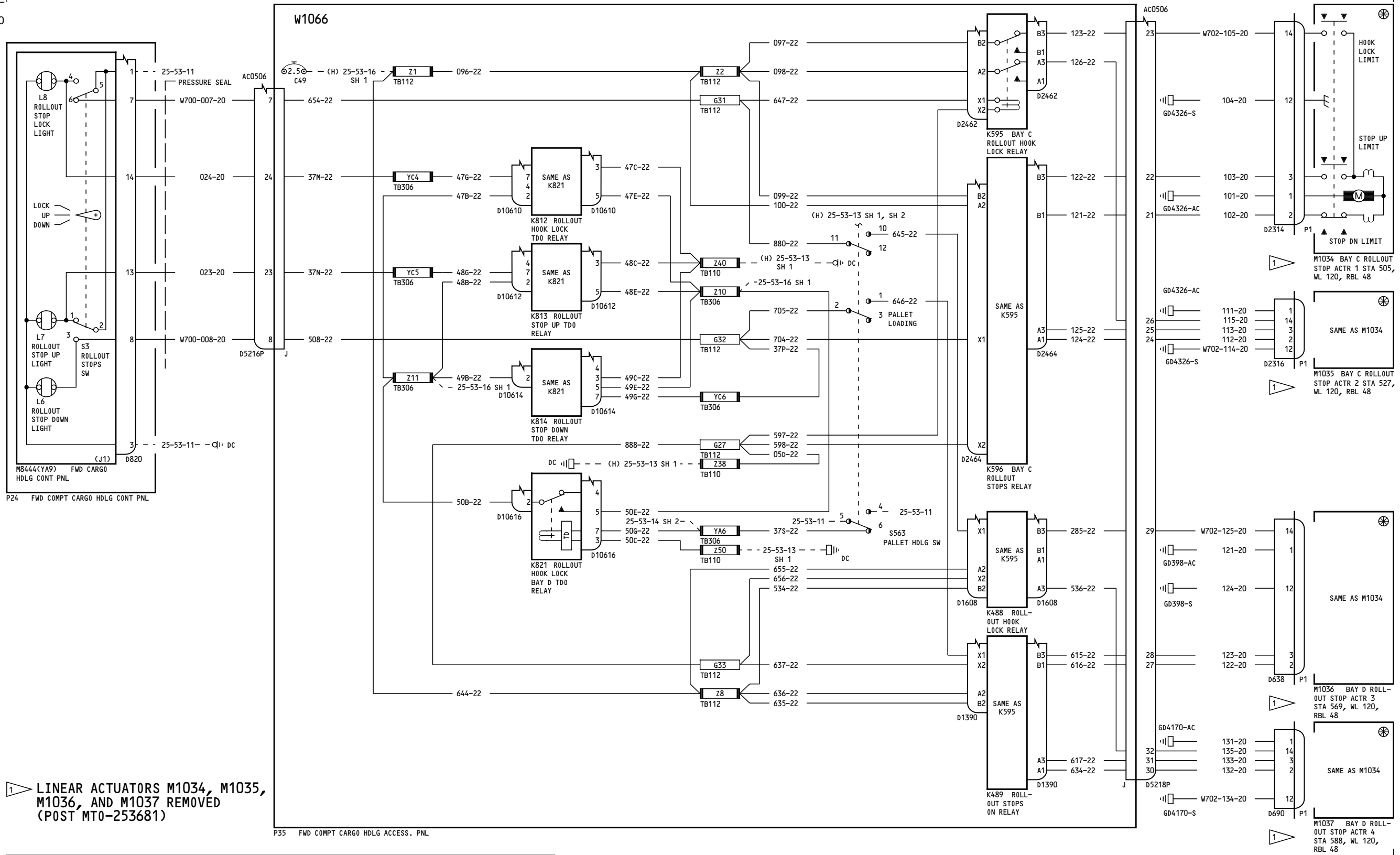

1 LINEAR ACTUATORS M1034, M1035, M1036, AND M1037 REMOVED (POST MT0-253681)

275-278

CARGO HANDLING-FORWARD LOWER LOBE ROLLOUT STOPS

25-53-17

Page 3A

D280T132

Jan 21/2005

Incorporates
MTO 253581

25-53-17

Page 3A

Jan 21/2005

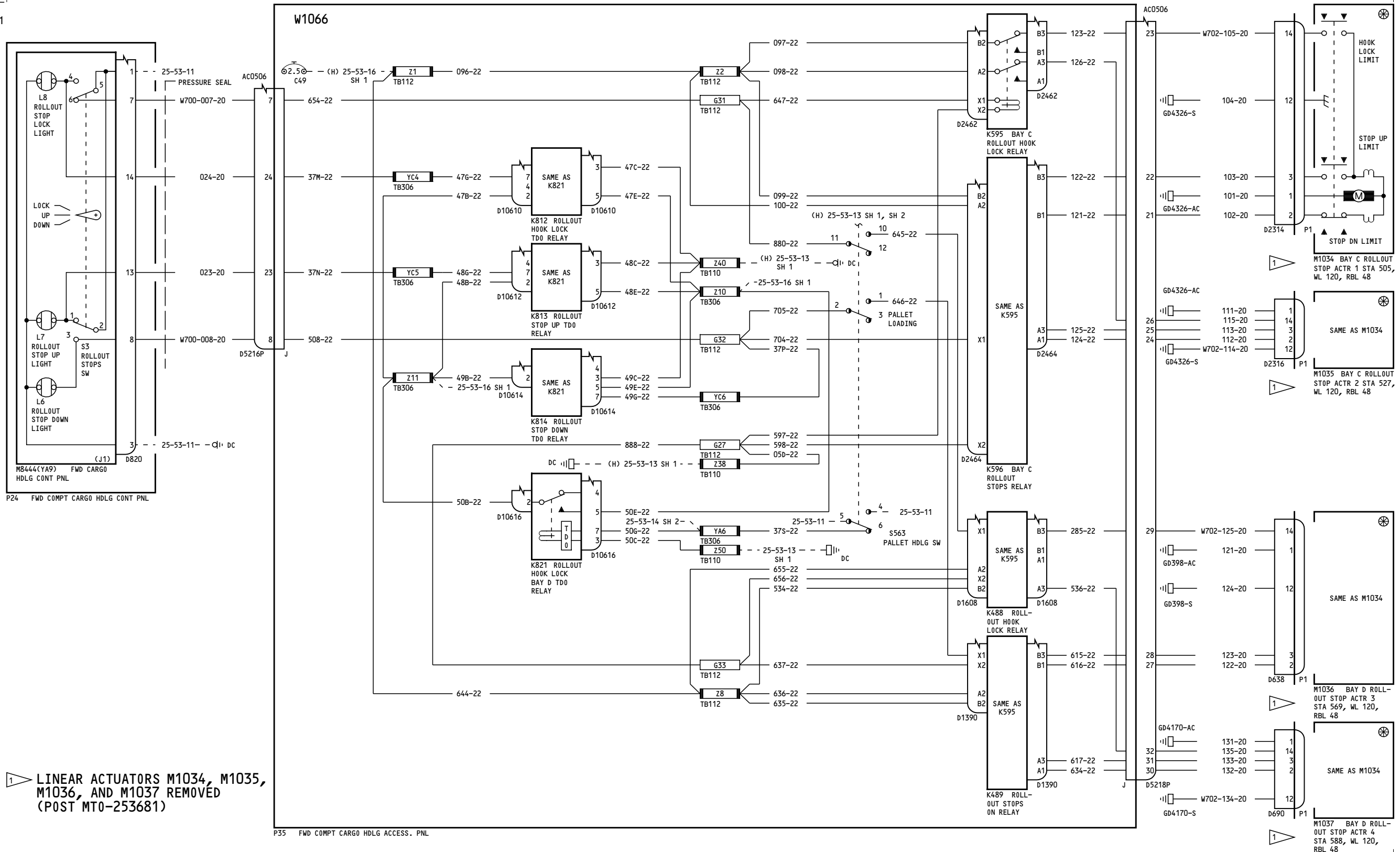

1 LINEAR ACTUATORS M1034, M1035, M1036, AND M1037 REMOVED (POST MT0-253681)

280

CARGO HANDLING-FORWARD LOWER LOBE ROLLOUT STOPS

D280T132

25-53-17

Page 4A

Jan 21/2005

Incorporates MTO 253581

25-53-17

Page 4A

Jan 21/2005

53

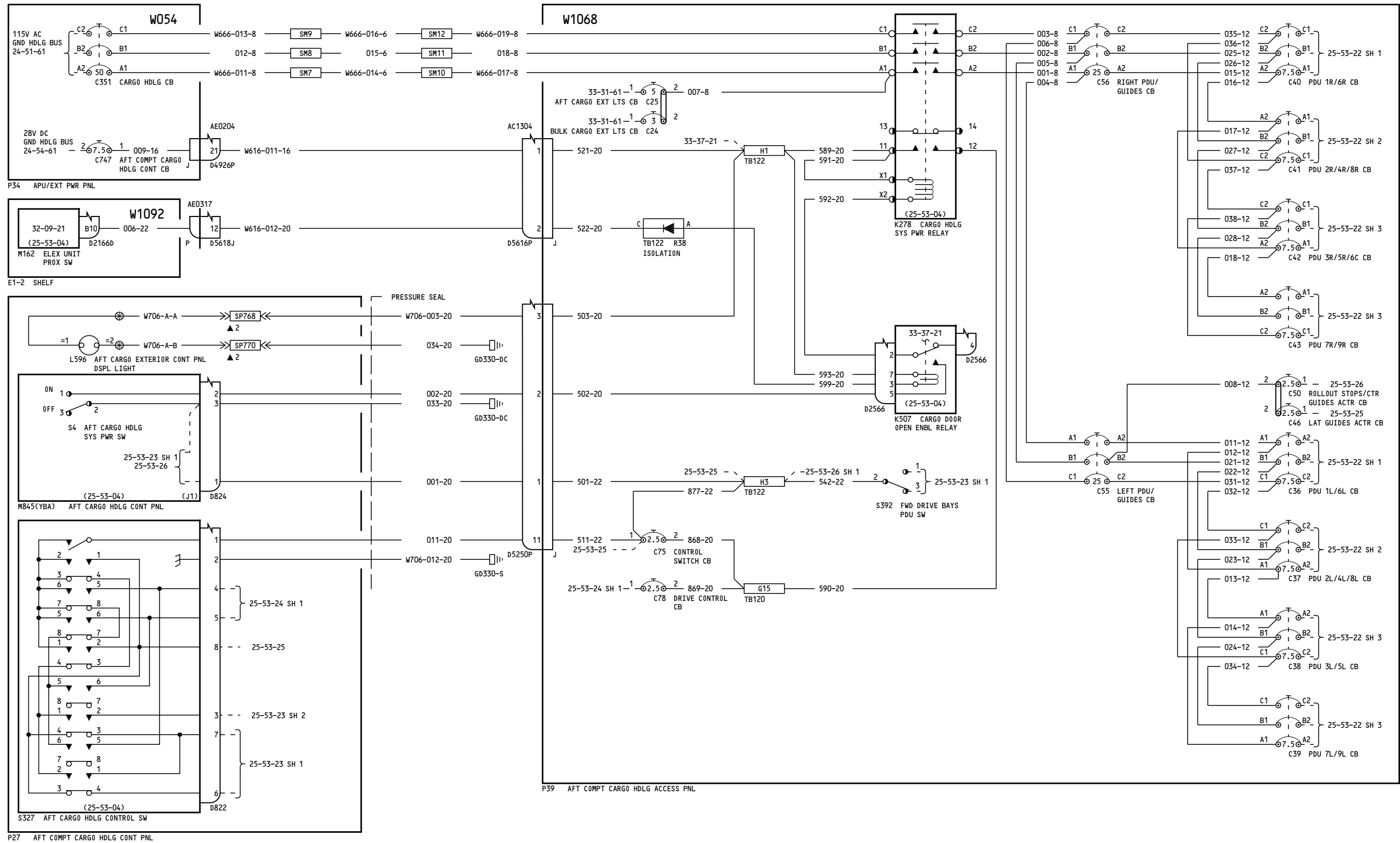

050-099

**CARGO HANDLING-
AFT LOWER LOBE
POWER DISTRIBUTION**

25-53-21

Page 1

Jan 21/2005

D280T132

25-53-21

Page 1

Jan 21/2005

-E

41

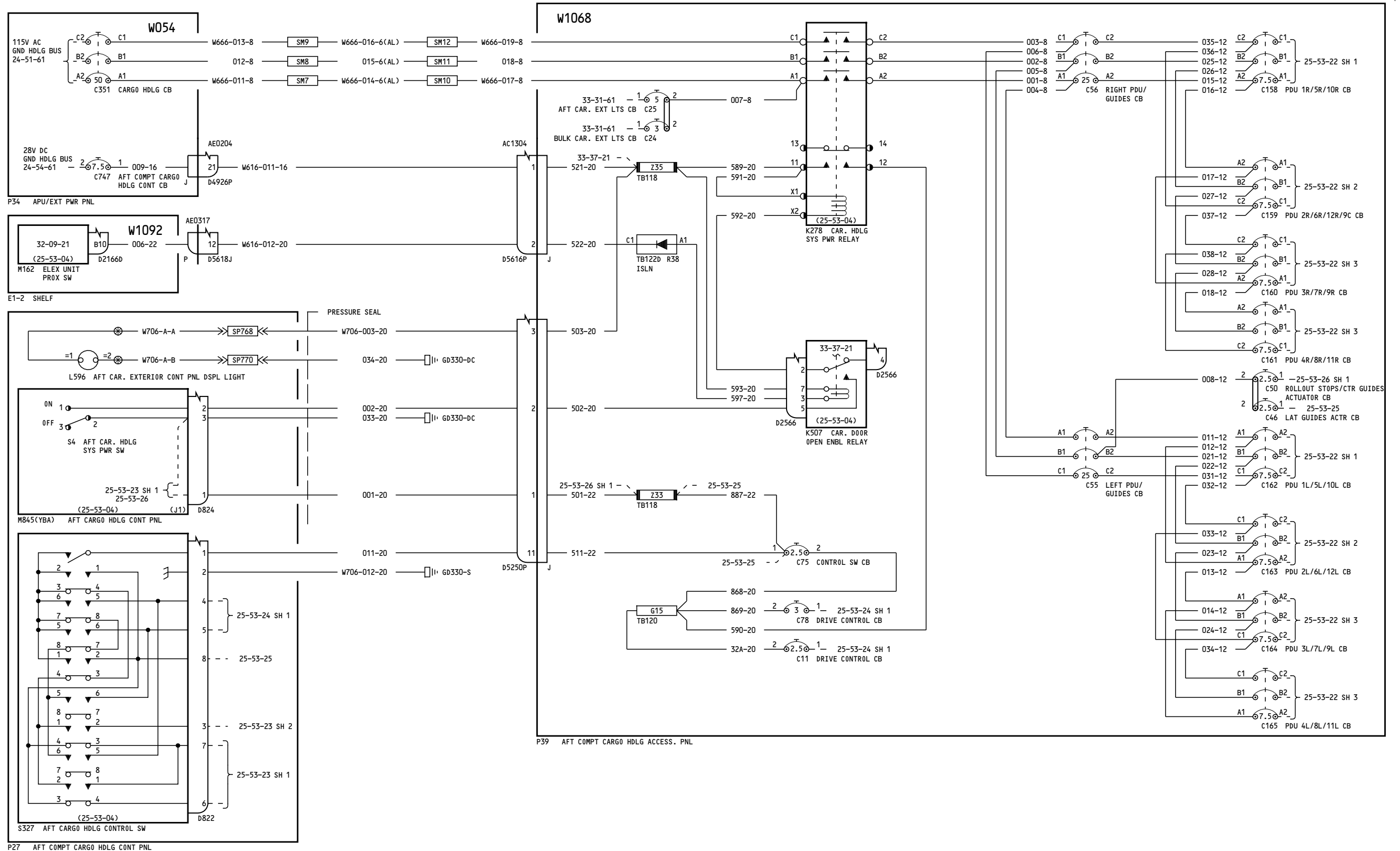

150-199

CARGO HANDLING-
AFT LOWER LOBE
POWER DISTRIBUTION

25-53-21

Page 2

Jan 21/2005

D280T132

25-53-21

Page 2

Jan 21/2005

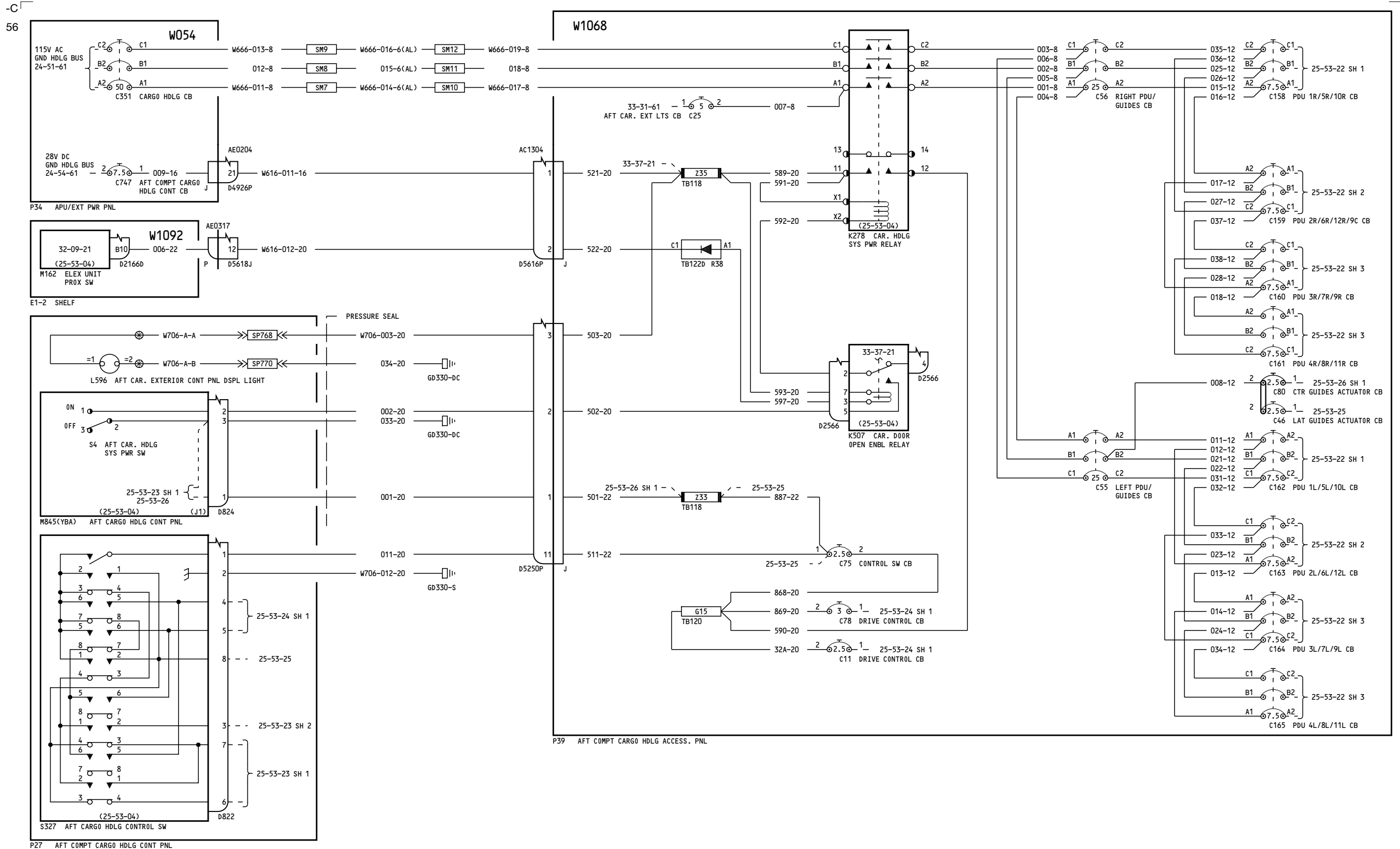

275-299

CARGO HANDLING-
AFT LOWER LOBE
POWER DISTRIBUTION

25-53-21

Page 3

Jan 21/2005

D280T132

25-53-21

Page 3

Jan 21/2005

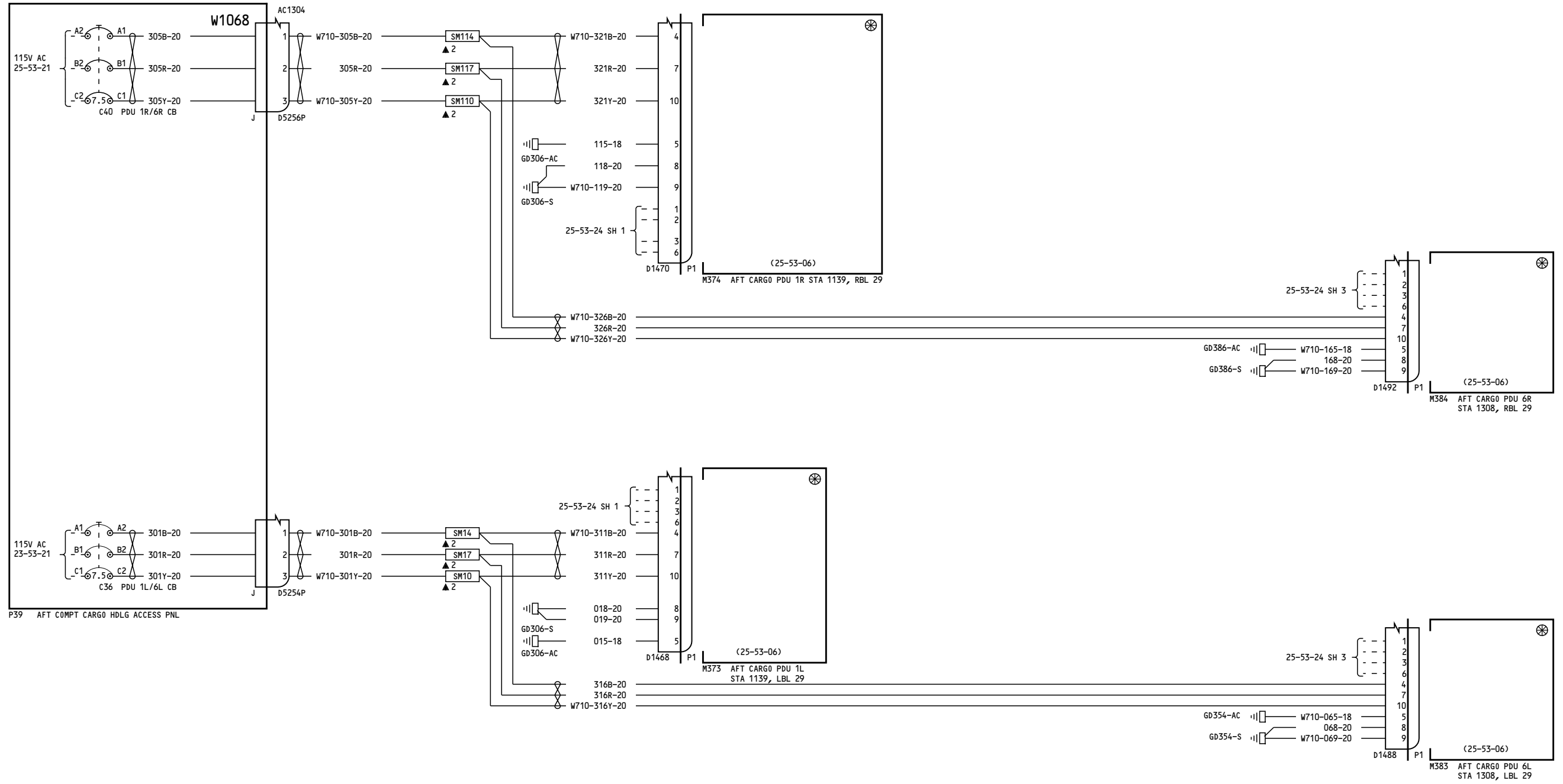

050-099

**CARGO HANDLING-
AFT LOWER LOBE
PDU POWER**

D280T132

25-53-22

Page 1
Sheet 1
Jan 21/2005

25-53-22

Page 1
Sheet 1
Jan 21/2005

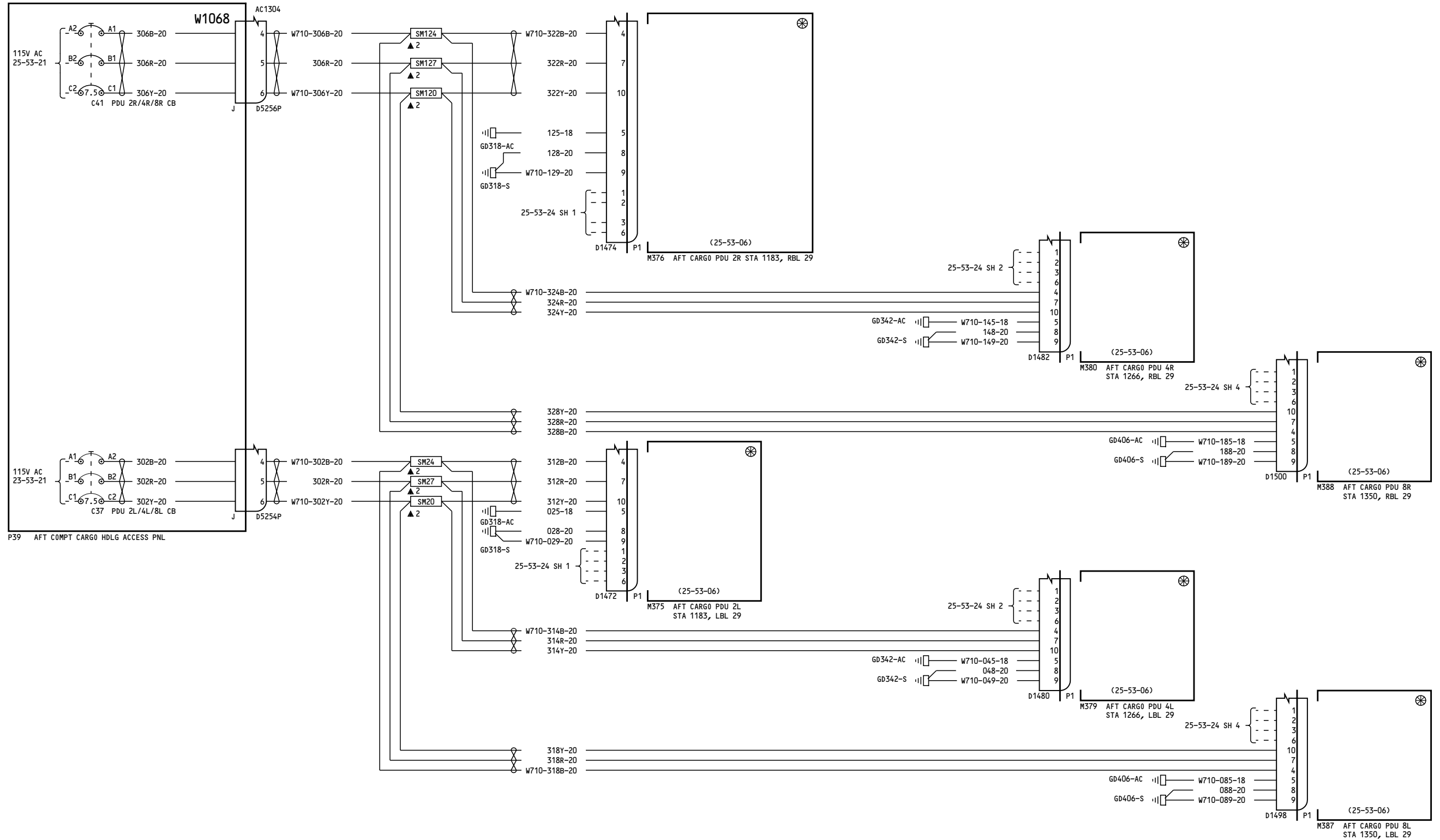

050-099

**CARGO HANDLING-
AFT LOWER LOBE
PDU POWER**

D280T132

25-53-22

Page 1
Sheet 2
Jan 21/2005

25-53-22

Page 1
Sheet 2
Jan 21/2005

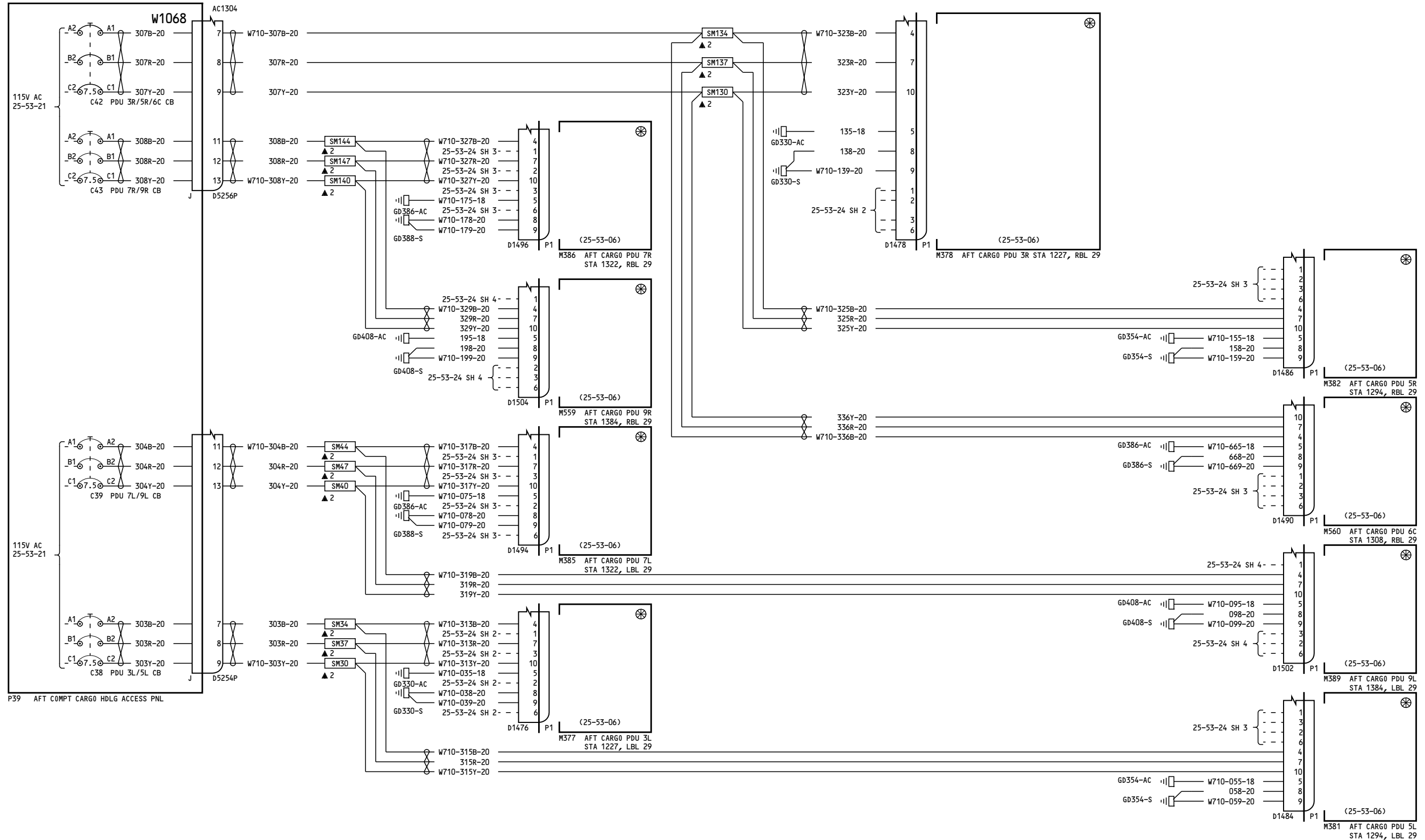

050-099

**CARGO HANDLING-
AFT LOWER LOBE
PDU POWER**

D280T132

25-53-22

Page 1
Sheet 3
Jan 21/2005

25-53-22

Page 1
Sheet 3
Jan 21/2005

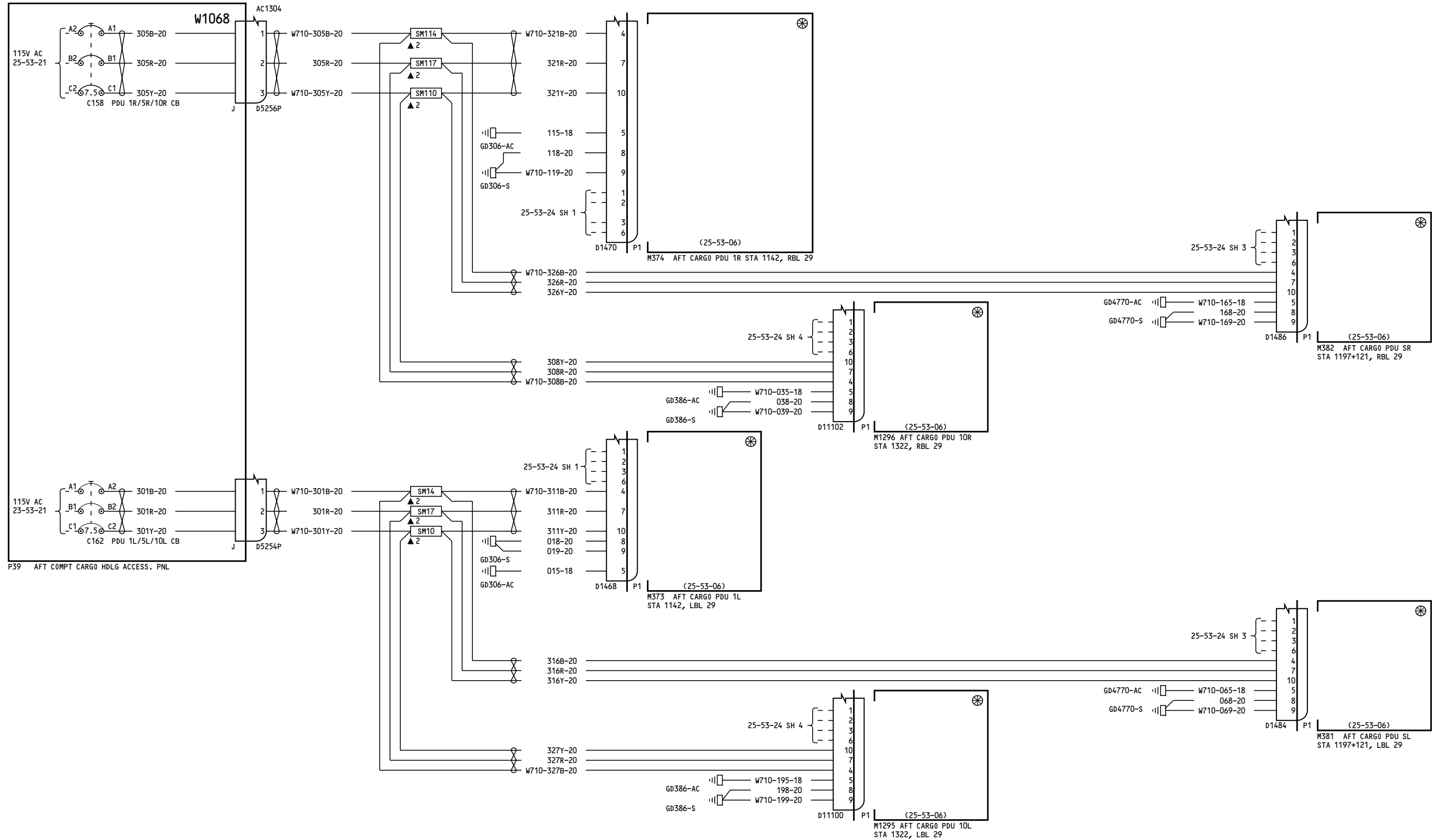

150-199, 275-278

**CARGO HANDLING-
AFT LOWER LOBE
PDU POWER**

D280T132

25-53-22

Page 2
Sheet 1
Jan 21/2005

25-53-22

Page 2
Sheet 1
Jan 21/2005

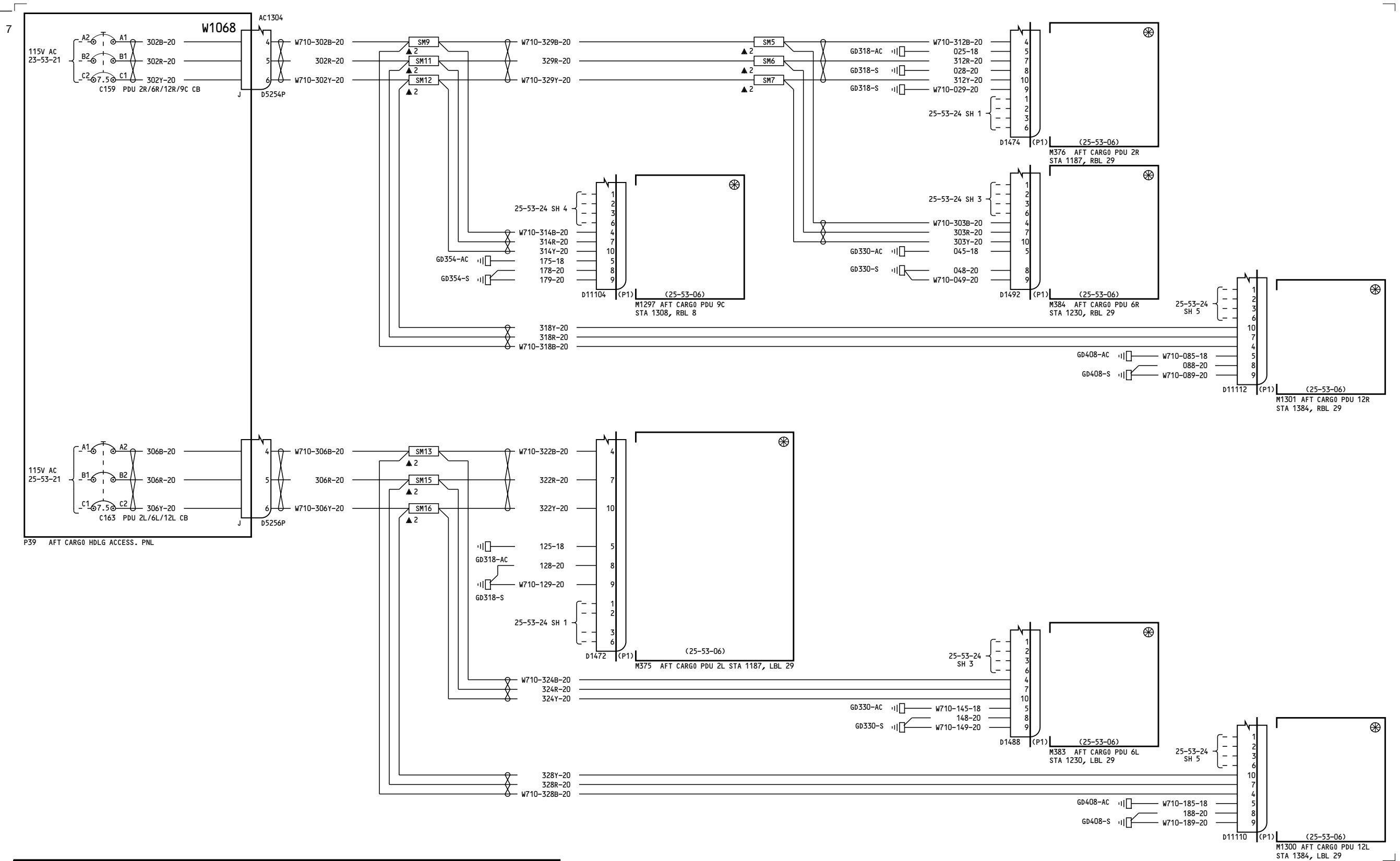

150-199, 275-278

**CARGO HANDLING-
AFT LOWER LOBE
PDU POWER**

D280T132

25-53-22

Page 2
Sheet 2
Jan 21/2005

25-53-22

Page 2
Sheet 2
Jan 21/2005

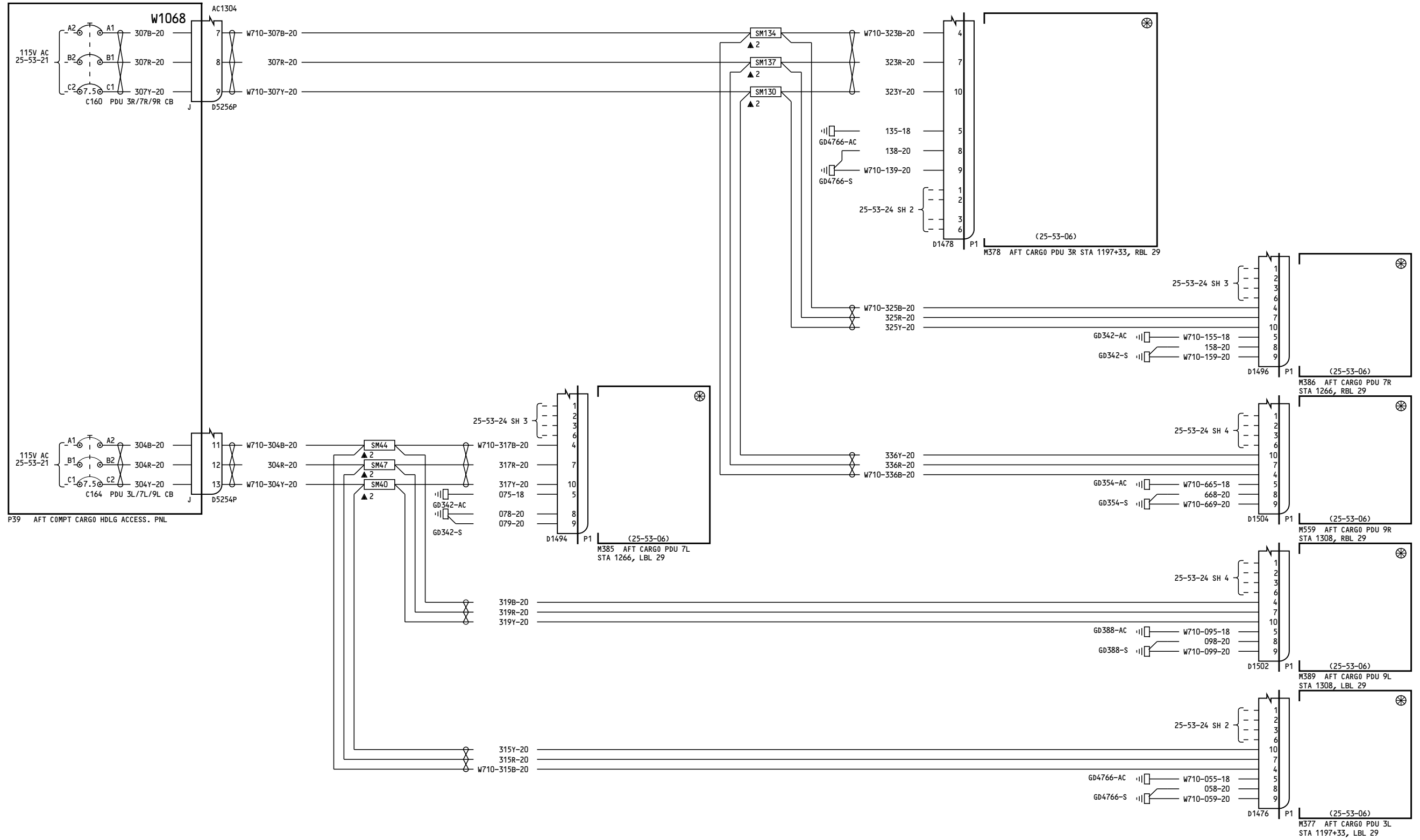

150-199, 275-278

**CARGO HANDLING-
AFT LOWER LOBE
PDU POWER**

D280T132

25-53-22

Page 2
Sheet 3
Jan 21/2005

25-53-22

Page 2
Sheet 3
Jan 21/2005

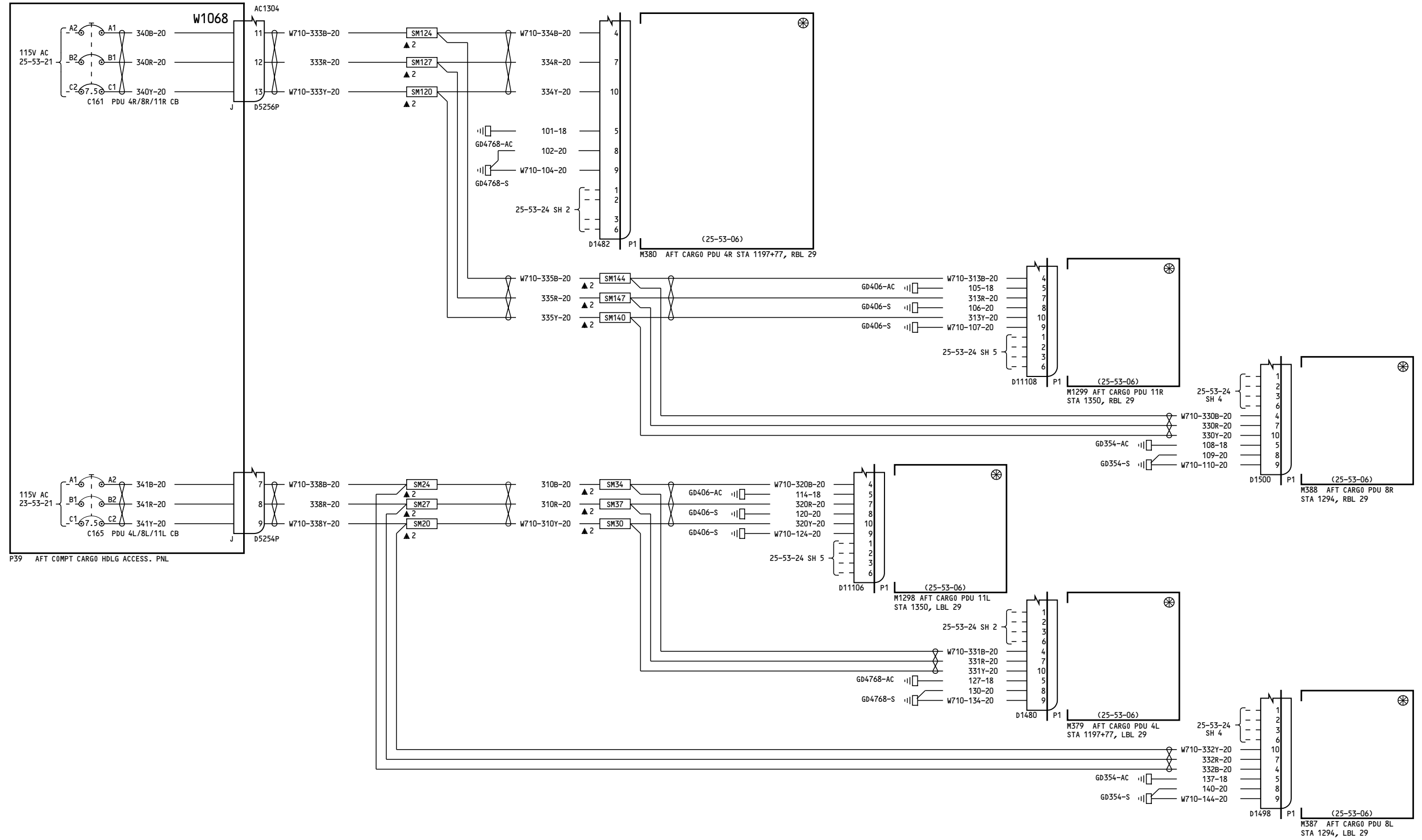

150-199, 275-278

**CARGO HANDLING-
AFT LOWER LOBE
PDU POWER**

D280T132

25-53-22

Page 2
Sheet 4
Jan 21/2005

25-53-22

Page 2
Sheet 4
Jan 21/2005

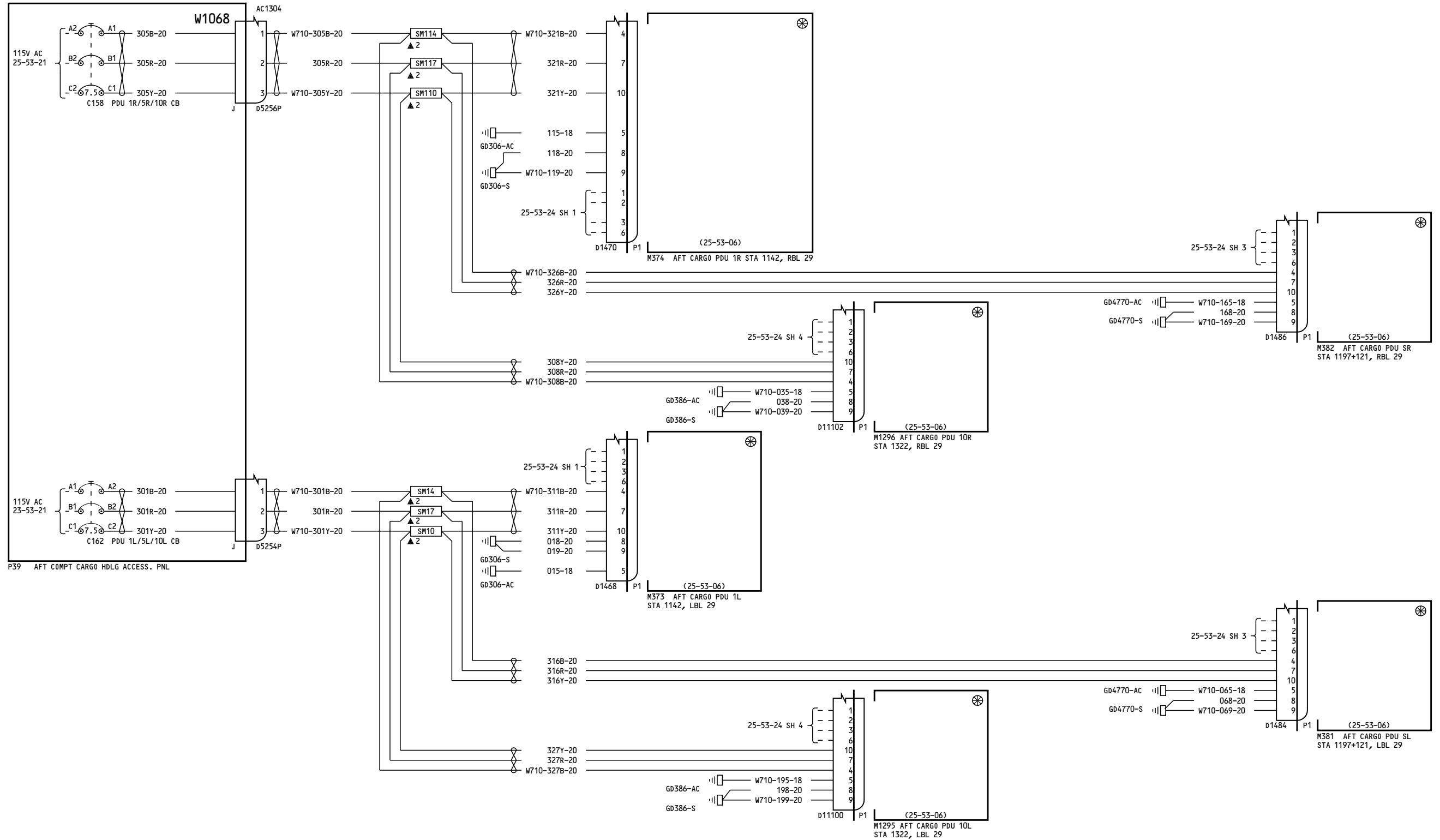

280-299

CARGO HANDLING-
AFT LOWER LOBE
PDU POWER

D280T132

25-53-22

Page 3
Sheet 1
Jan 21/2005

25-53-22

Page 3
Sheet 1
Jan 21/2005

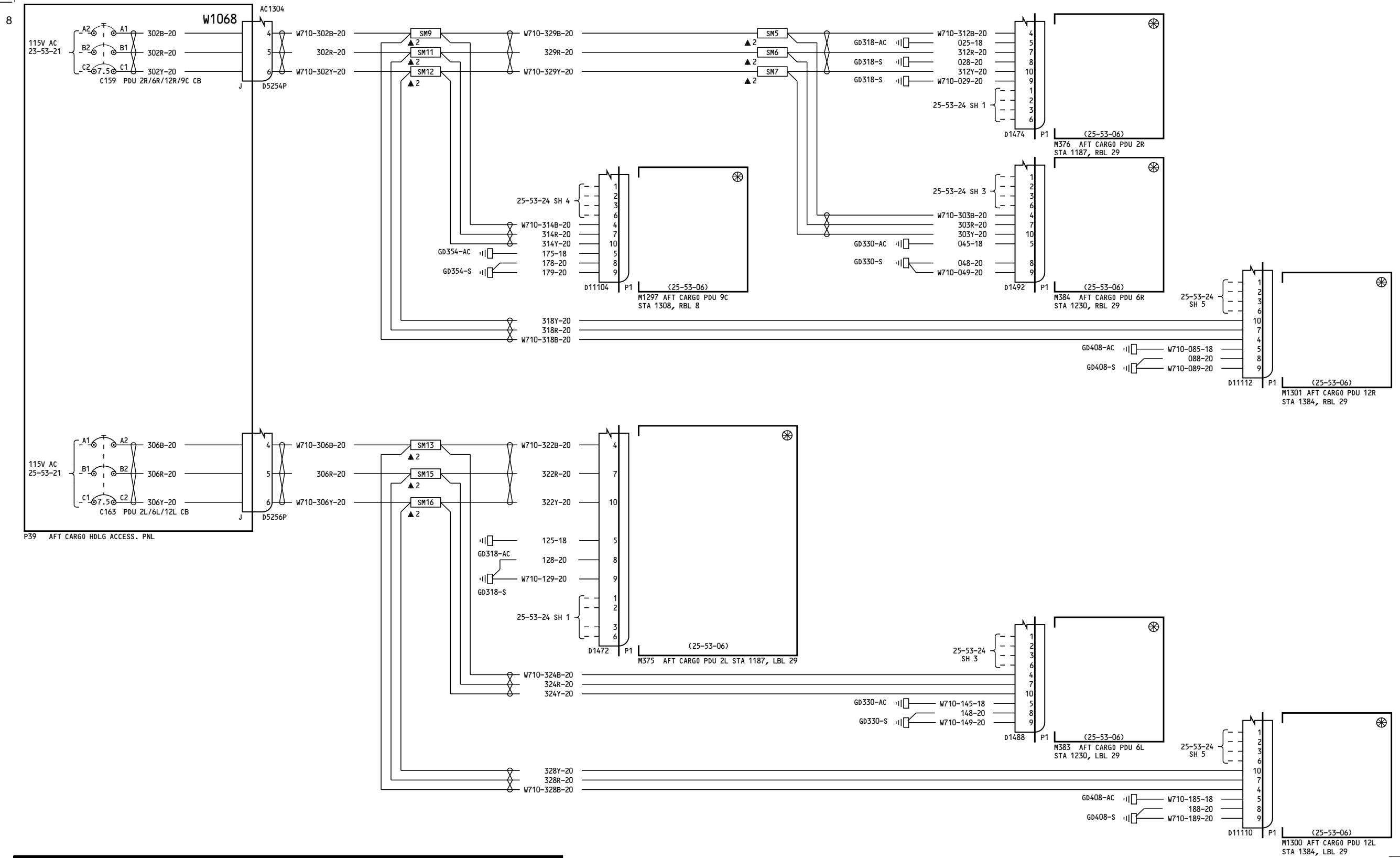

280-299

**CARGO HANDLING-
AFT LOWER LOBE
PDU POWER**

D280T132

25-53-22

Page 3
Sheet 2
Jan 21/2005

25-53-22

Page 3
Sheet 2
Jan 21/2005

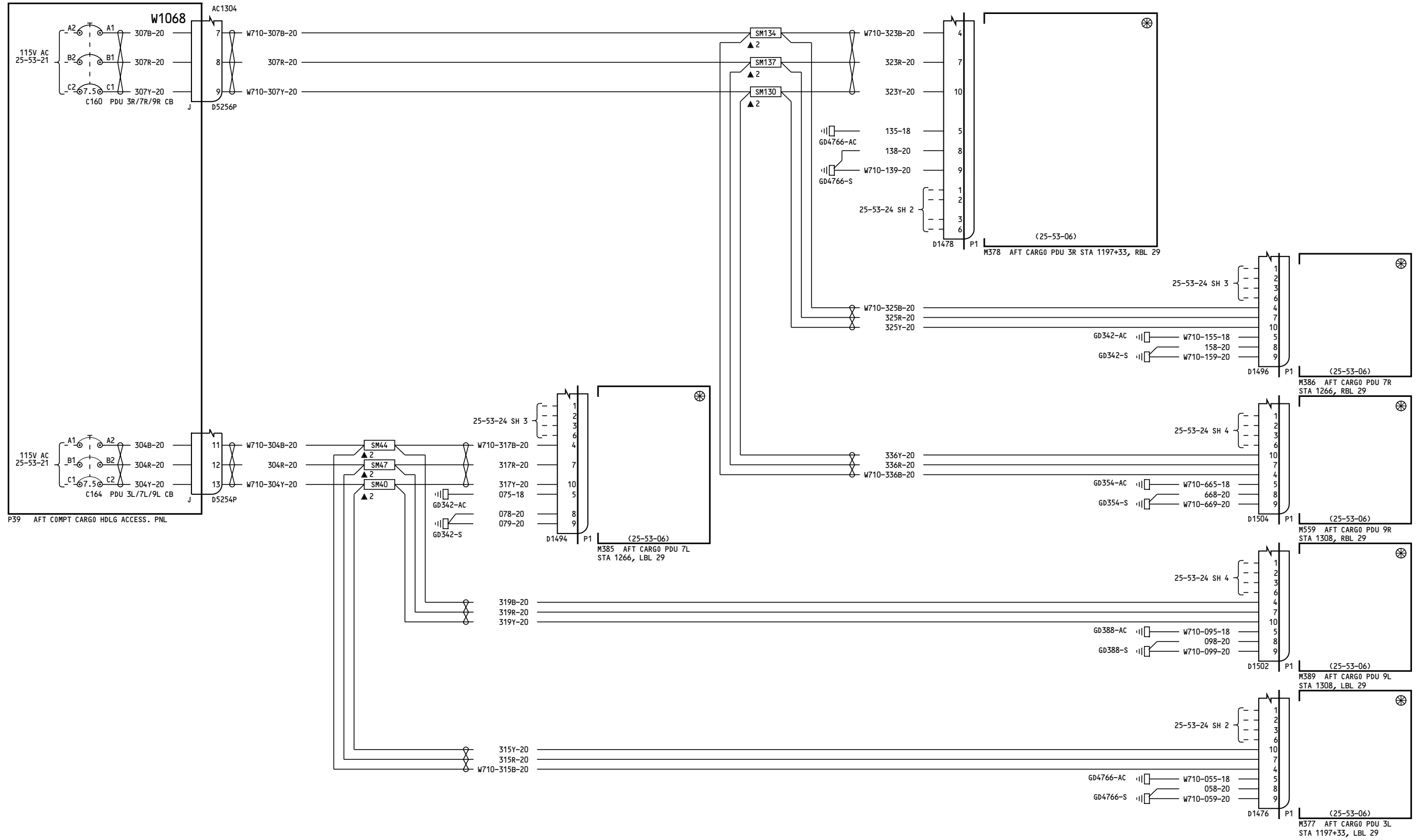

280-299

CARGO HANDLING-
AFT LOWER LOBE
PDU POWER

D280T132

25-53-22

Page 3
Sheet 3
Jan 21/2005

25-53-22

Page 3
Sheet 3
Jan 21/2005

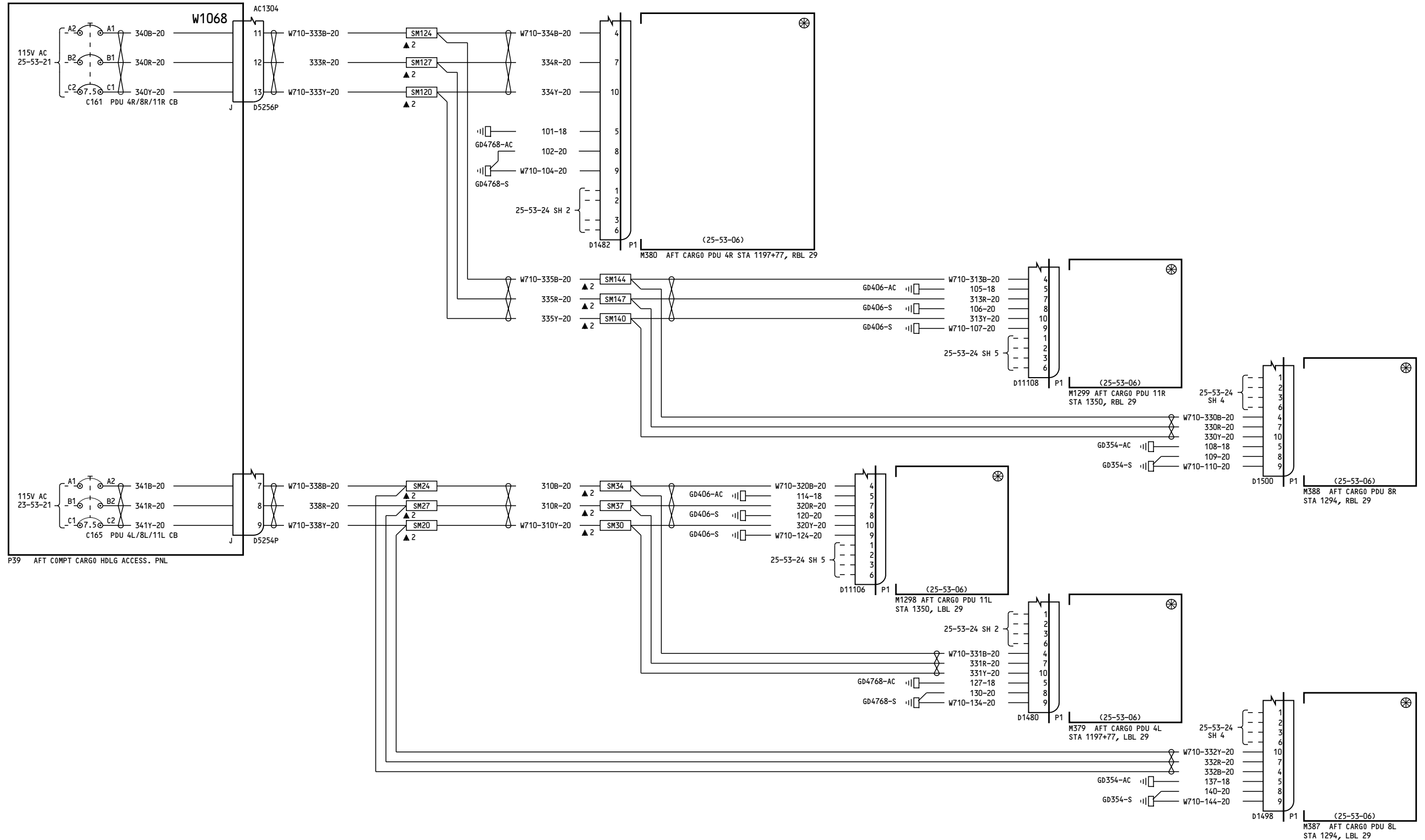

280-299

**CARGO HANDLING-
AFT LOWER LOBE
PDU POWER**

D280T132

25-53-22

Page 3
Sheet 4
Jan 21/2005

25-53-22

Page 3
Sheet 4
Jan 21/2005

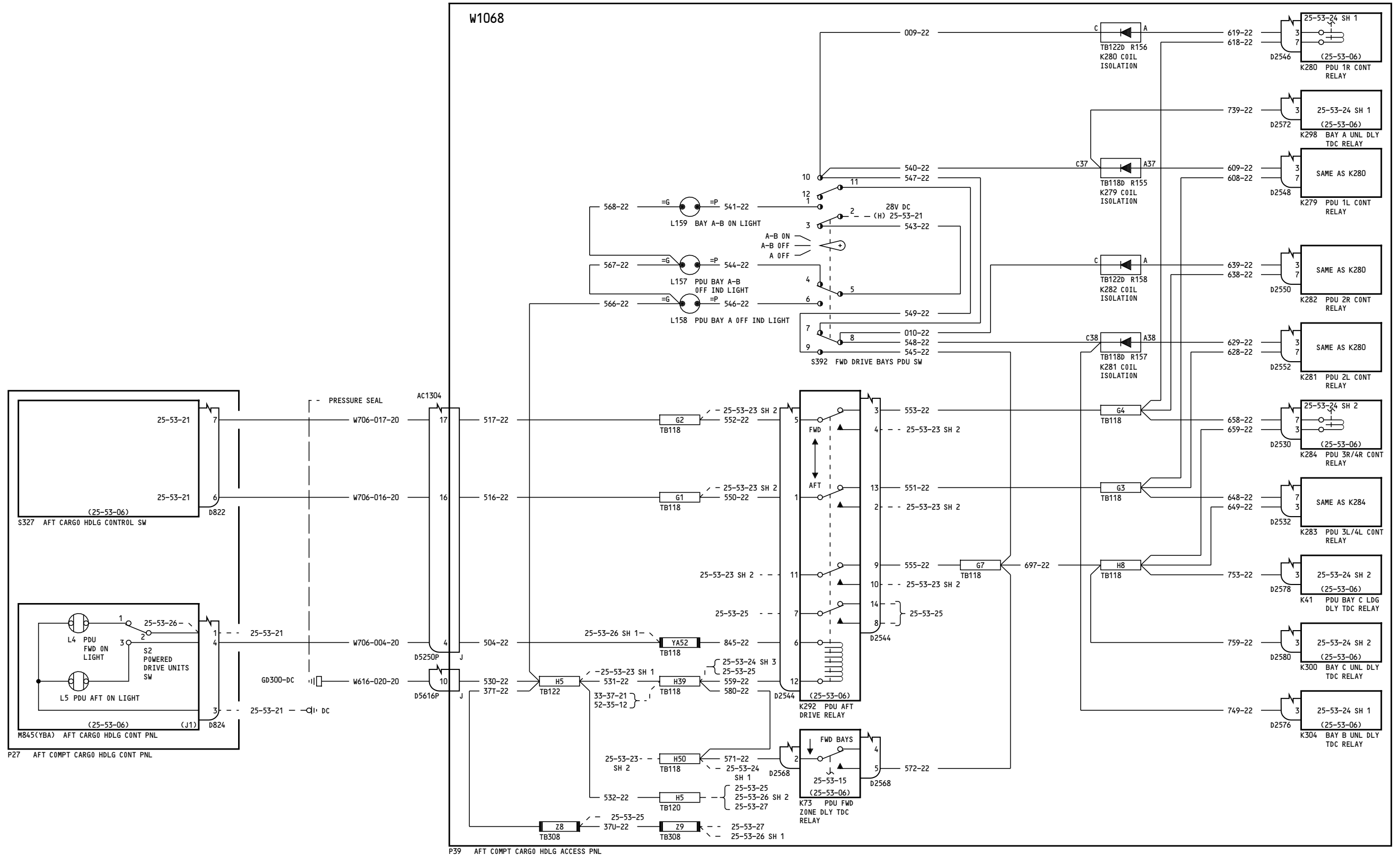

050-099

CARGO HANDLING-
AFT LOWER LOBE
FWD/AFT PDU CONTROL

25-53-23

Page 1
Sheet 1
Jan 21/2005

D280T132

25-53-23

Page 1
Sheet 1
Jan 21/2005

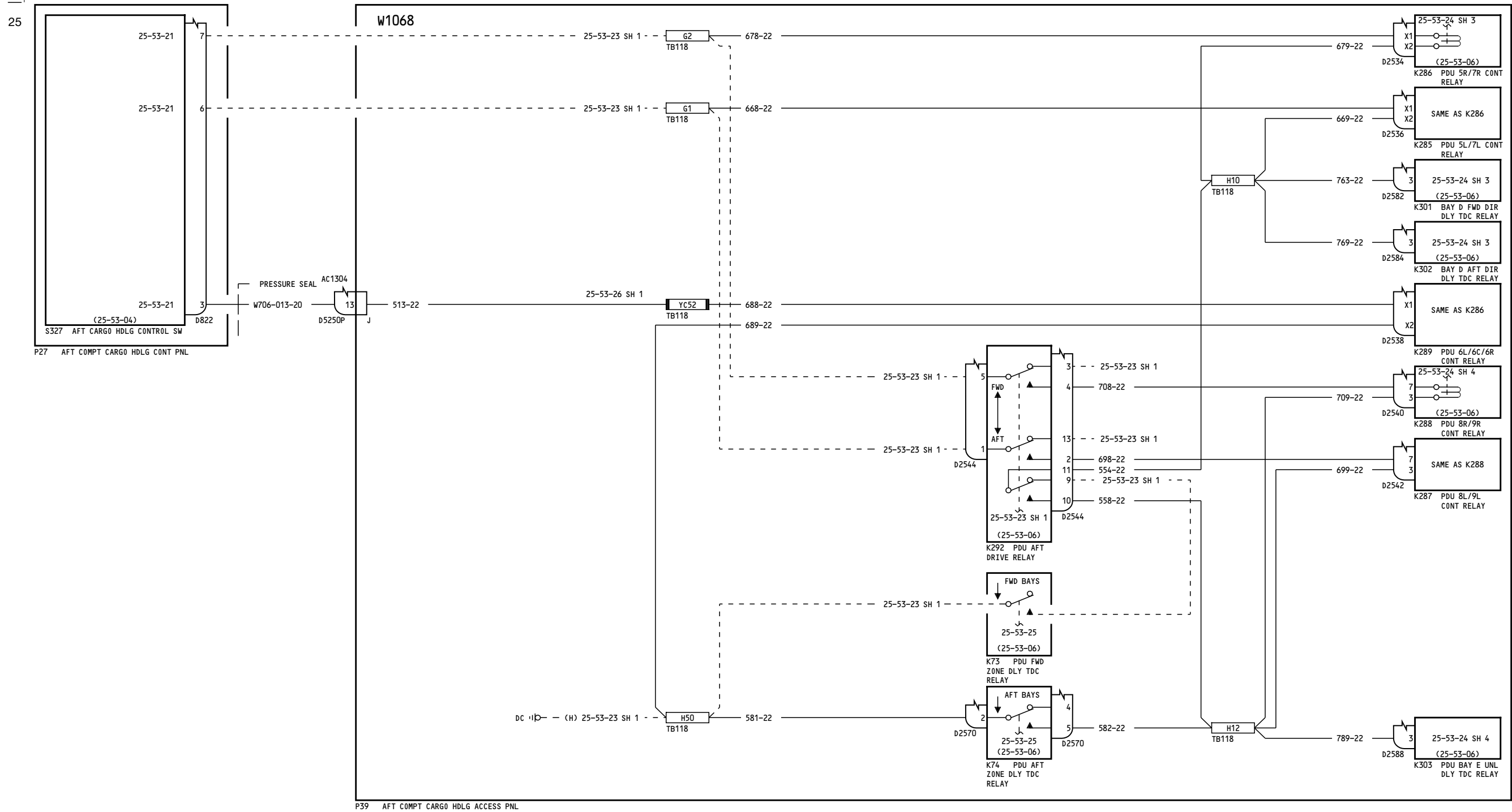

050-099

CARGO HANDLING-
AFT LOWER LOBE
FWD/AFT PDU CONTROL

25-53-23

Page 1
Sheet 2
Jan 21/2005

D280T132

25-53-23

Page 1
Sheet 2
Jan 21/2005

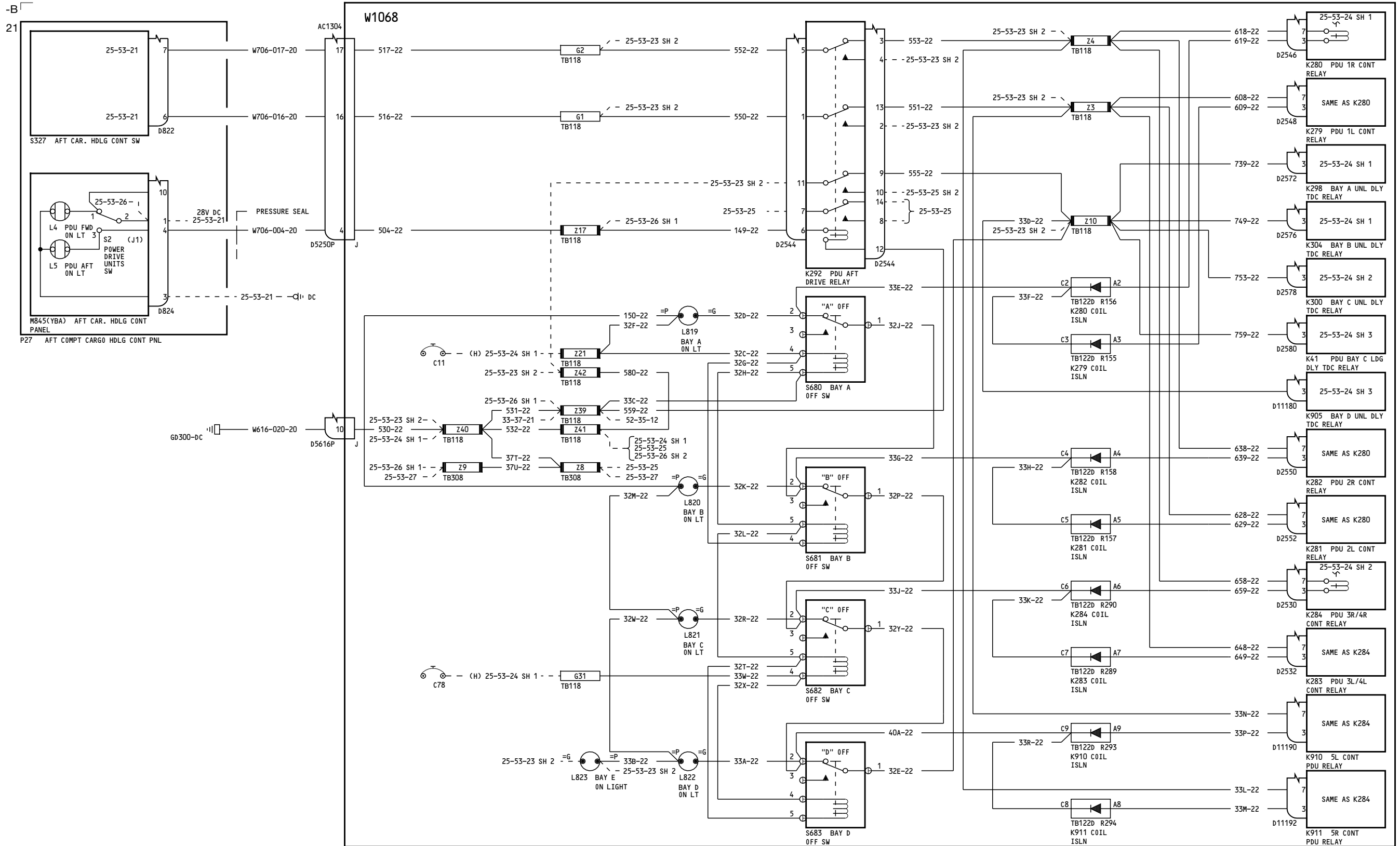

150-199

CARGO HANDLING-
AFT LOWER LOBE
FWD/AFT PDU CONTROL

25-53-23

Page 2
Sheet 1
Jan 21/2005

D280T132

25-53-23

Page 2
Sheet 1
Jan 21/2005

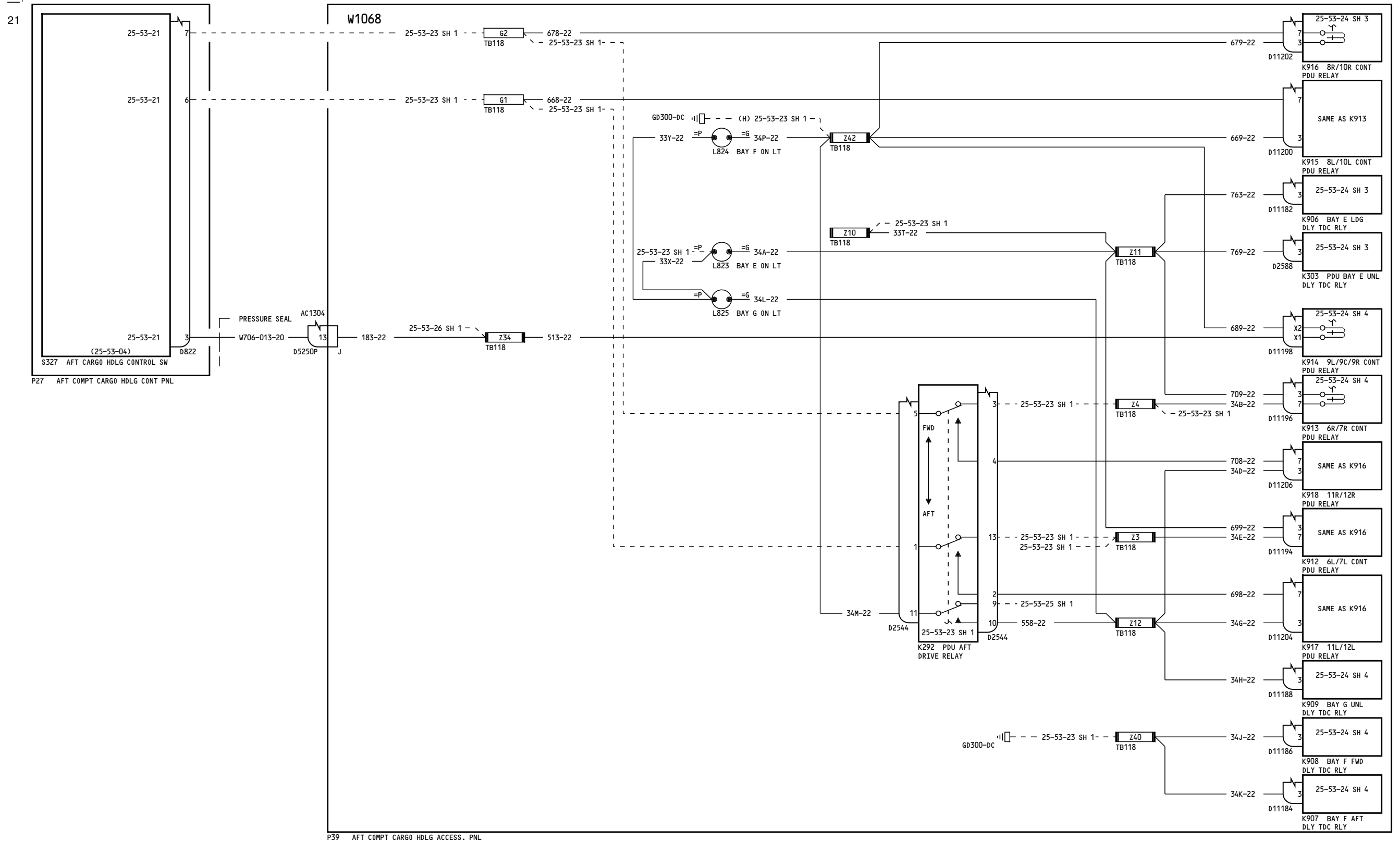

150-199

CARGO HANDLING-
AFT LOWER LOBE
FWD/AFT PDU CONTROL

25-53-23

Page 2
Sheet 2
Jan 21/2005

D280T132

25-53-23

Page 2
Sheet 2
Jan 21/2005

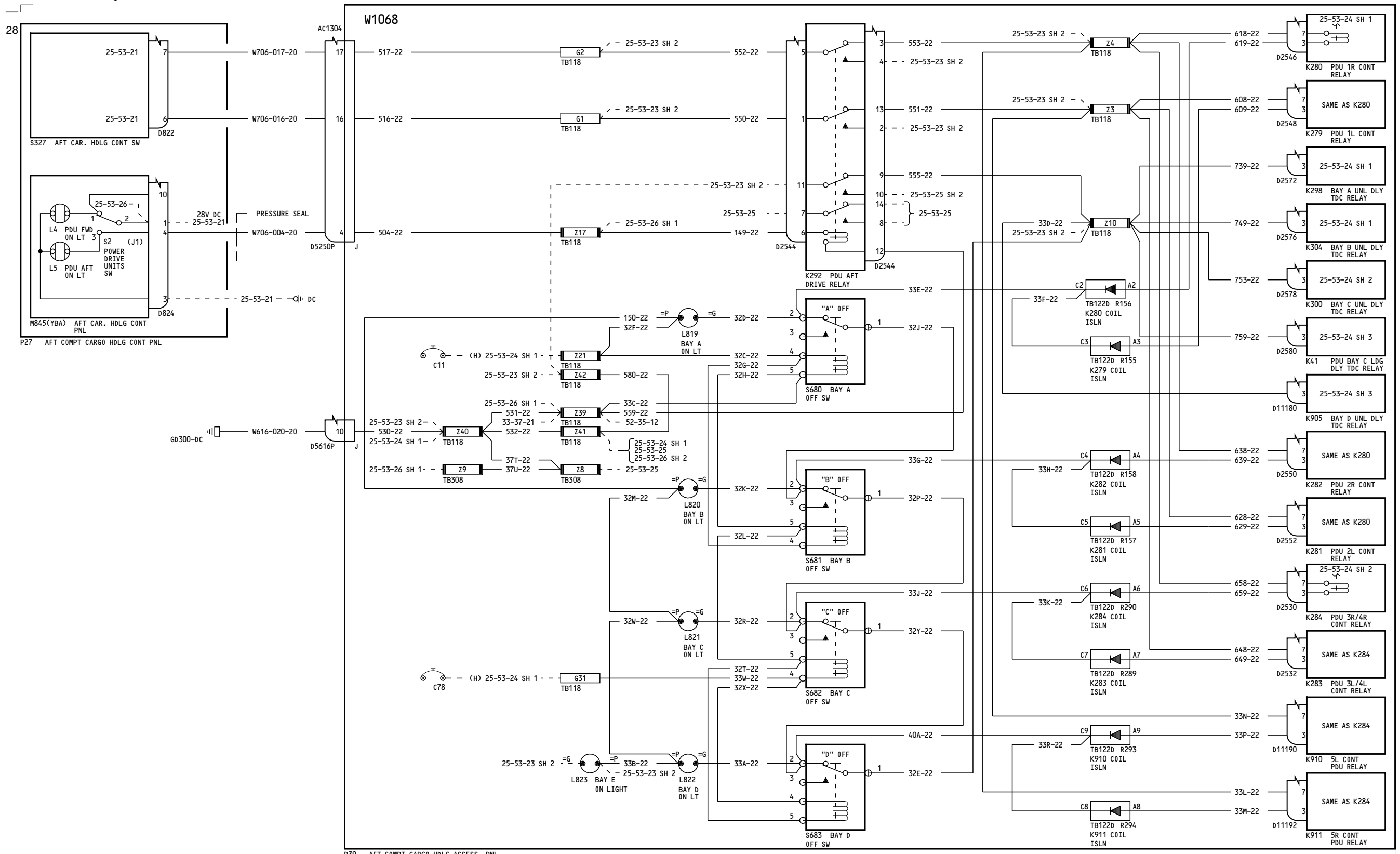

275-299

**CARGO HANDLING-
AFT LOWER LOBE
FWD/AFT PDU CONTROL**

25-53-23

Page 3
Sheet 1
Jan 21/2005

D280T132

25-53-23

Page 3
Sheet 1
Jan 21/2005

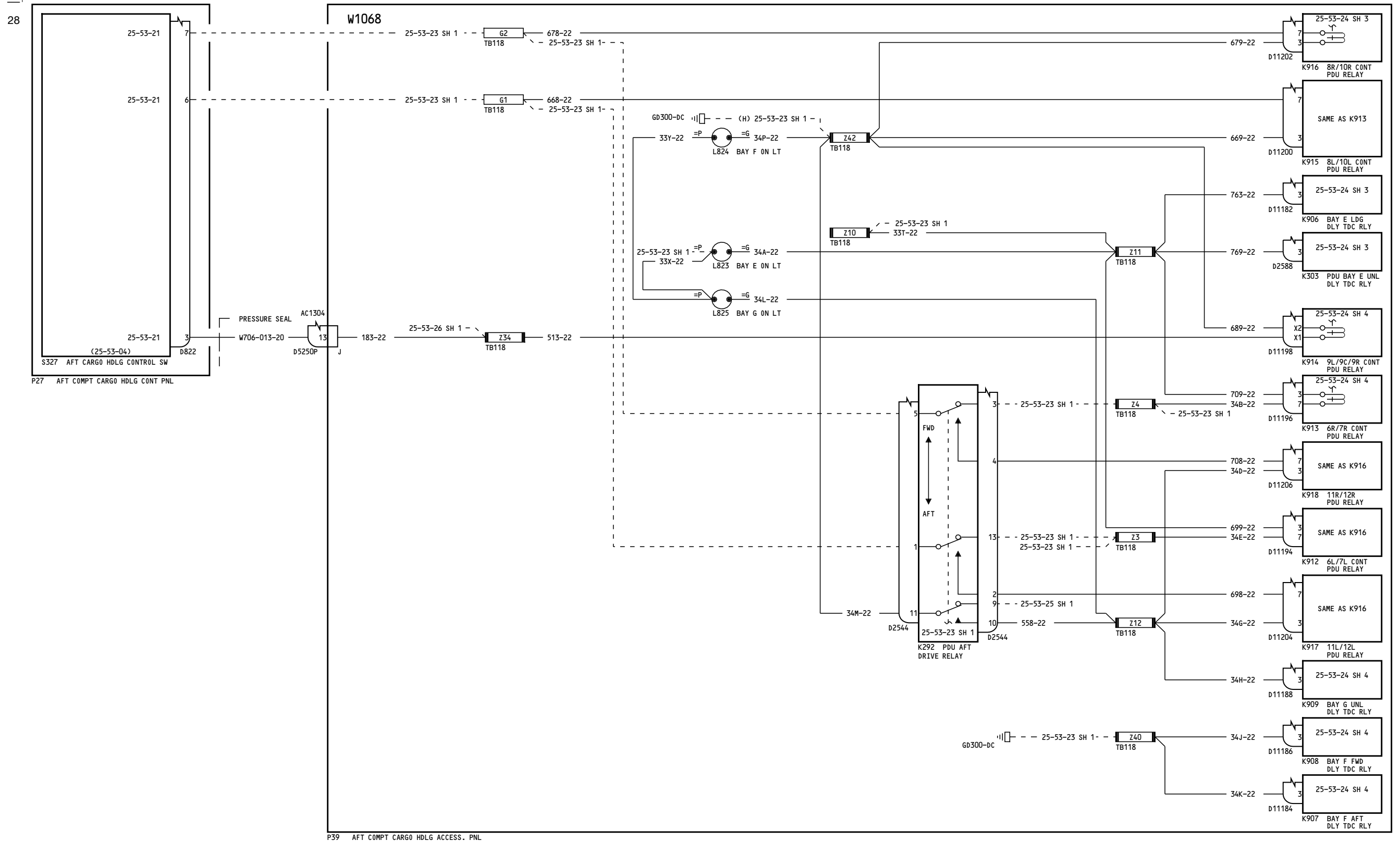

275-299

**CARGO HANDLING-
AFT LOWER LOBE
FWD/AFT PDU CONTROL**

25-53-23

Page 3
Sheet 2
Jan 21/2005

D280T132

25-53-23

Page 3
Sheet 2
Jan 21/2005

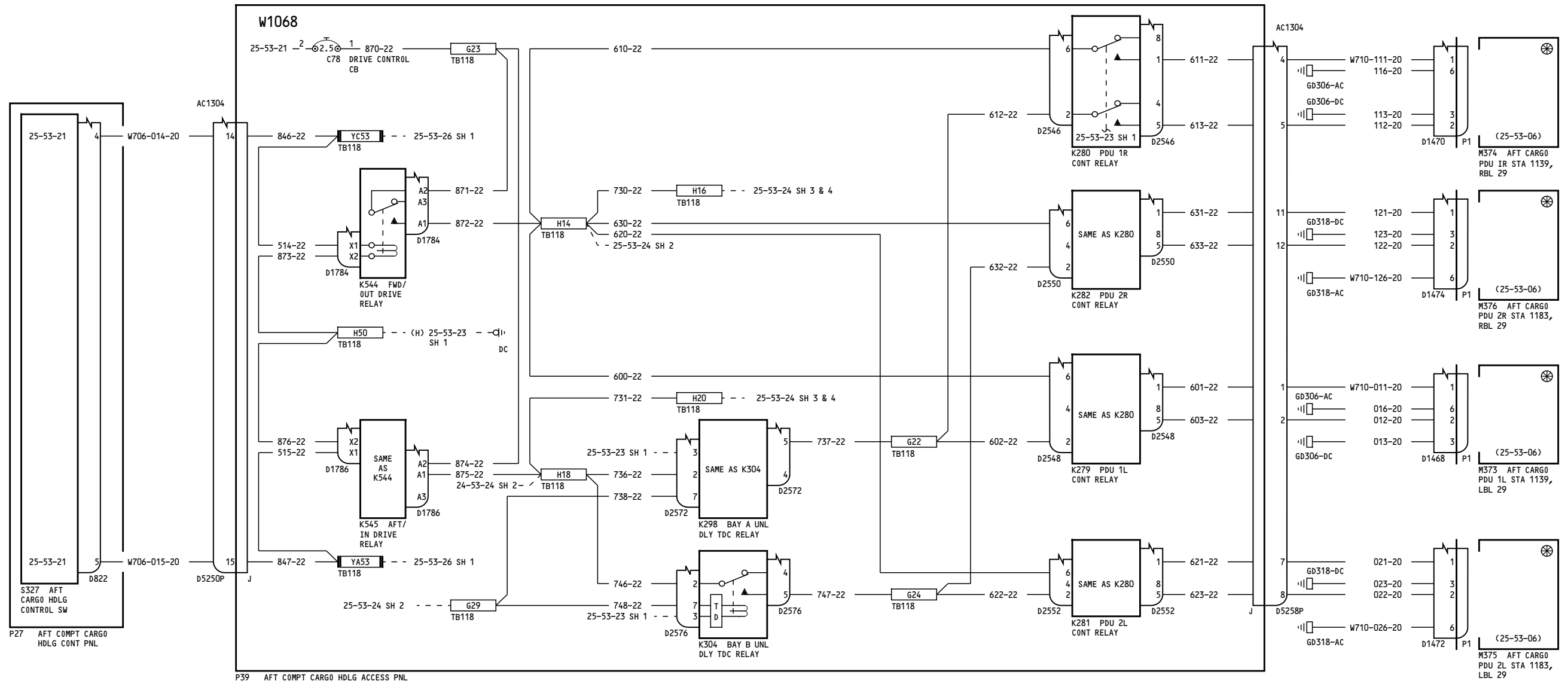

050-099

CARGO HANDLING-
AFT LOWER LOBE PDU
LOAD/UNLOAD CONTROL

D280T132

25-53-24

Page 1
Sheet 1
Jan 21/2005

25-53-24

Page 1
Sheet 1
Jan 21/2005

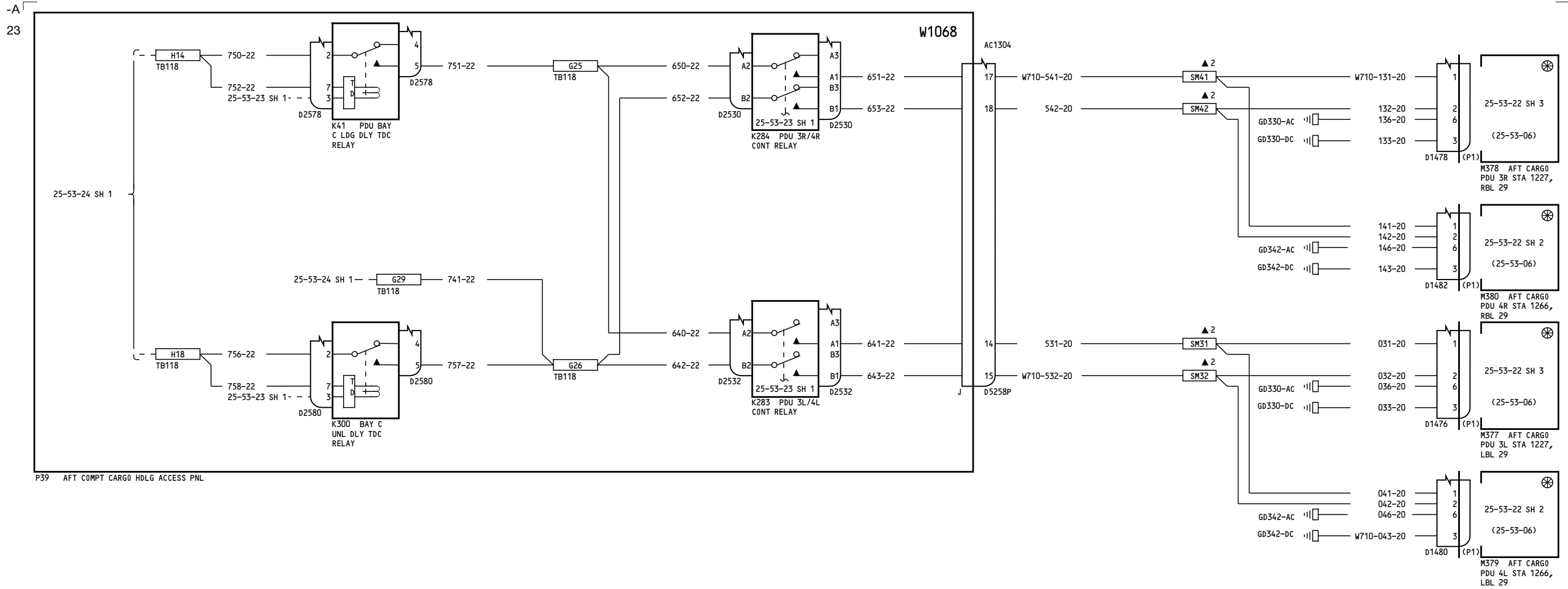

P39 AFT COMPT CARGO HDLG ACCESS PNL

050-099

**CARGO HANDLING-
AFT LOWER LOBE PDU
LOAD/UNLOAD CONTROL**

D280T132

25-53-24

Page 1
Sheet 2
Jan 21/2005

25-53-24

Page 1
Sheet 2
Jan 21/2005

23

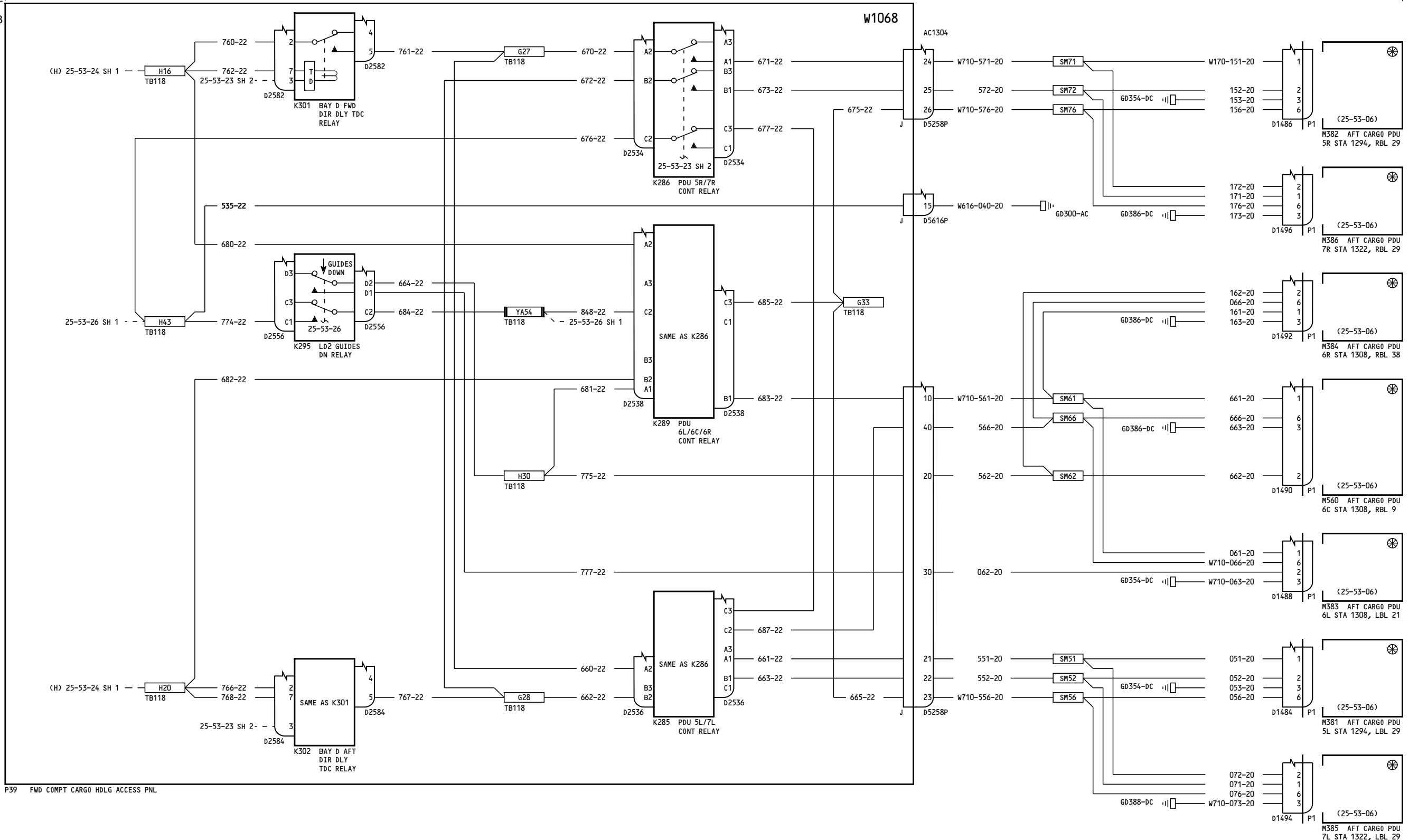

P39 FWD COMPT CARGO HDLG ACCESS PNL

050-099

CARGO HANDLING-
AFT LOWER LOBE PDU
LOAD/UNLOAD CONTROL

D280T132

25-53-24

Page 1
Sheet 3
Jan 21/2005

25-53-24

Page 1
Sheet 3
Jan 21/2005

23

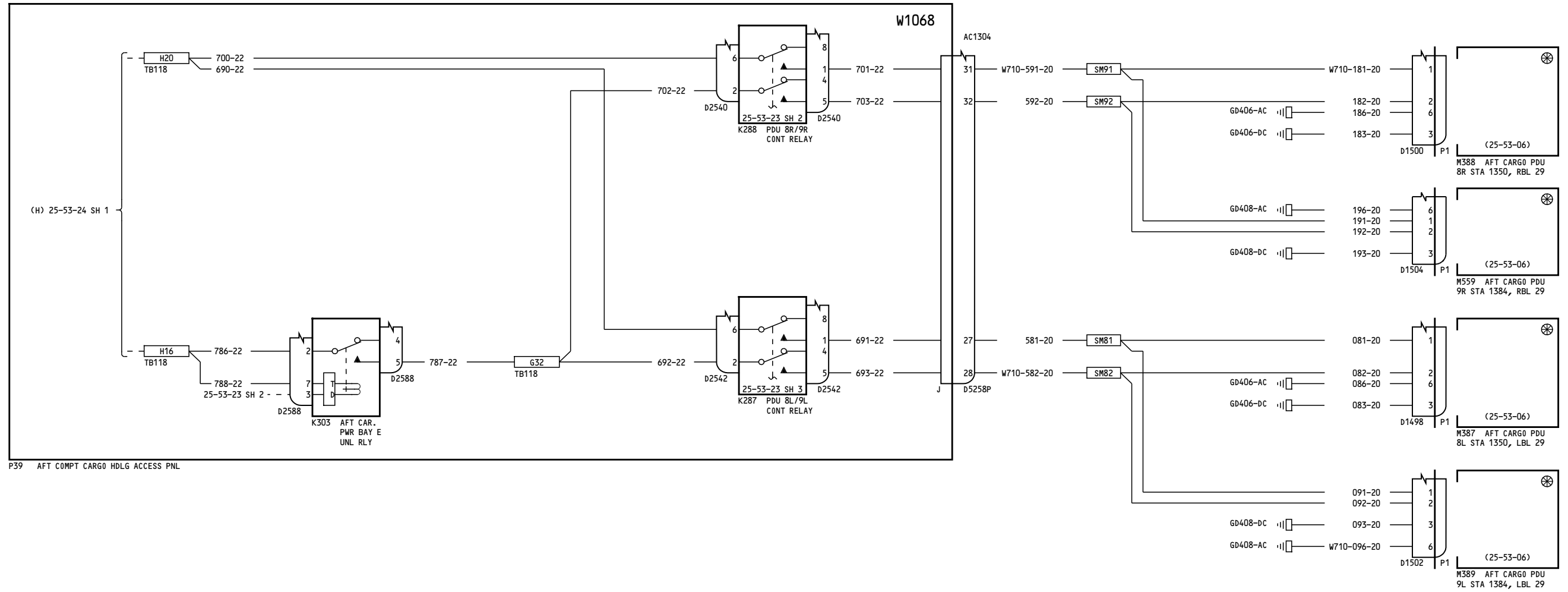

050-099

**CARGO HANDLING-
AFT LOWER LOBE PDU
LOAD/UNLOAD CONTROL**

D280T132

25-53-24

Page 1
Sheet 4
Jan 21/2005

25-53-24

Page 1
Sheet 4
Jan 21/2005

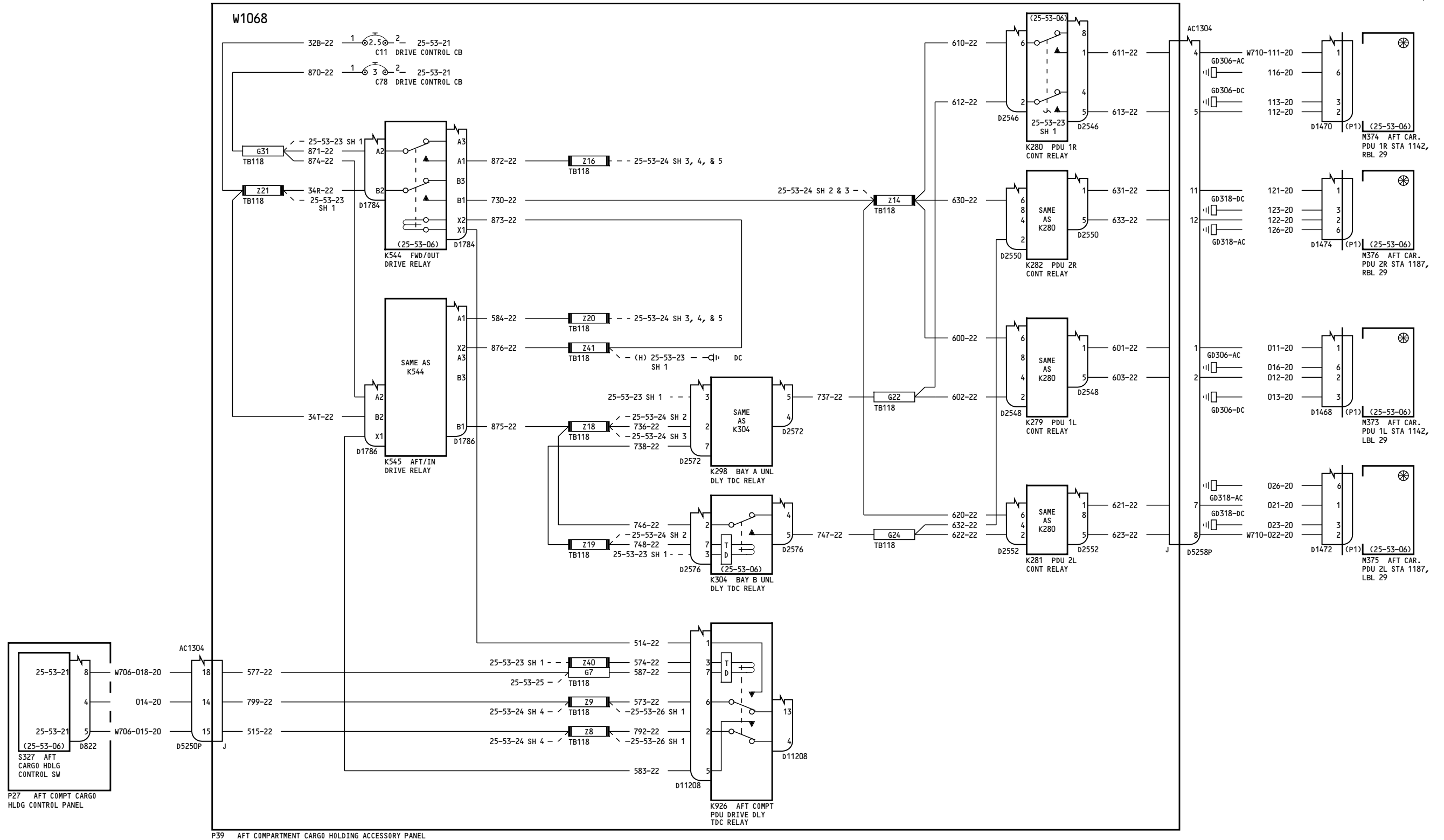

150-199, 275-299

CARGO HANDLING-
AFT LOWER LOBE PDU
LOAD/UNLOAD CONTROL

D280T132

25-53-24

Page 2
Sheet 1
Jan 21/2005

25-53-24

Page 2
Sheet 1
Jan 21/2005

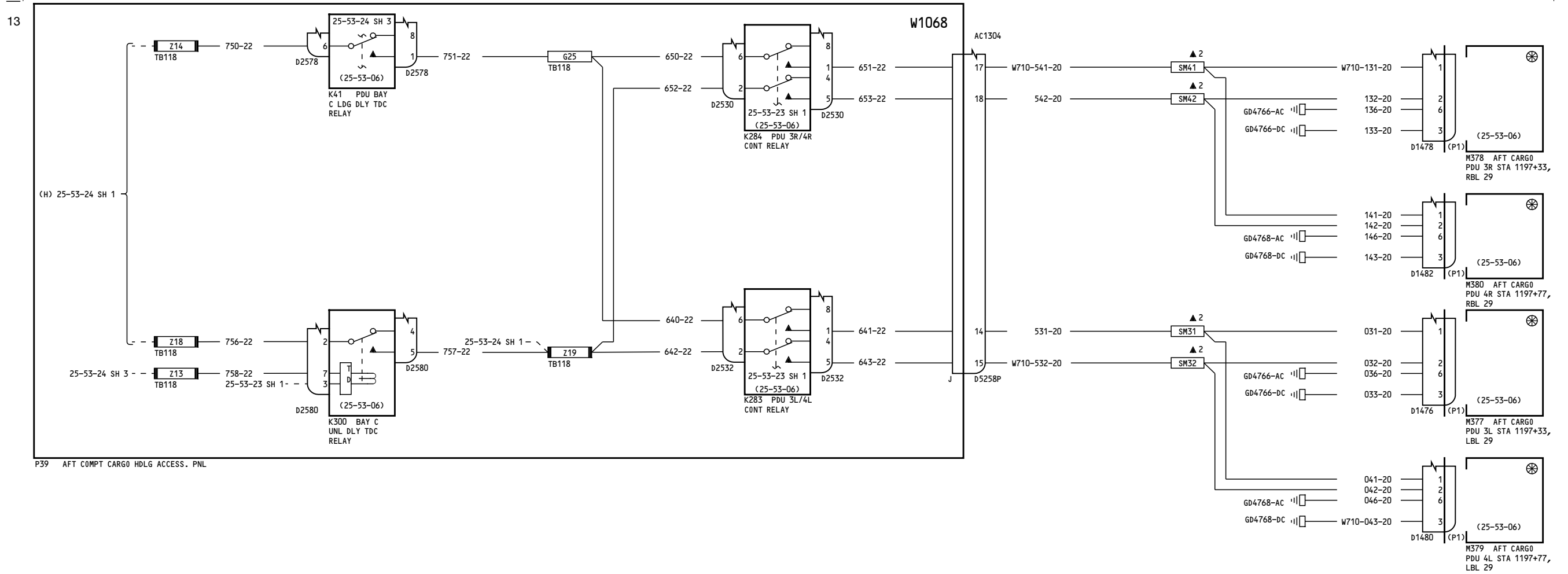

P39 AFT COMPT CARGO HDLG ACCESS. PNL

150-199, 275-299

**CARGO HANDLING-
AFT LOWER LOBE PDU
LOAD/UNLOAD CONTROL**

D280T132

25-53-24

Page 2
Sheet 2
Jan 21/2005

25-53-24

Page 2
Sheet 2
Jan 21/2005

13

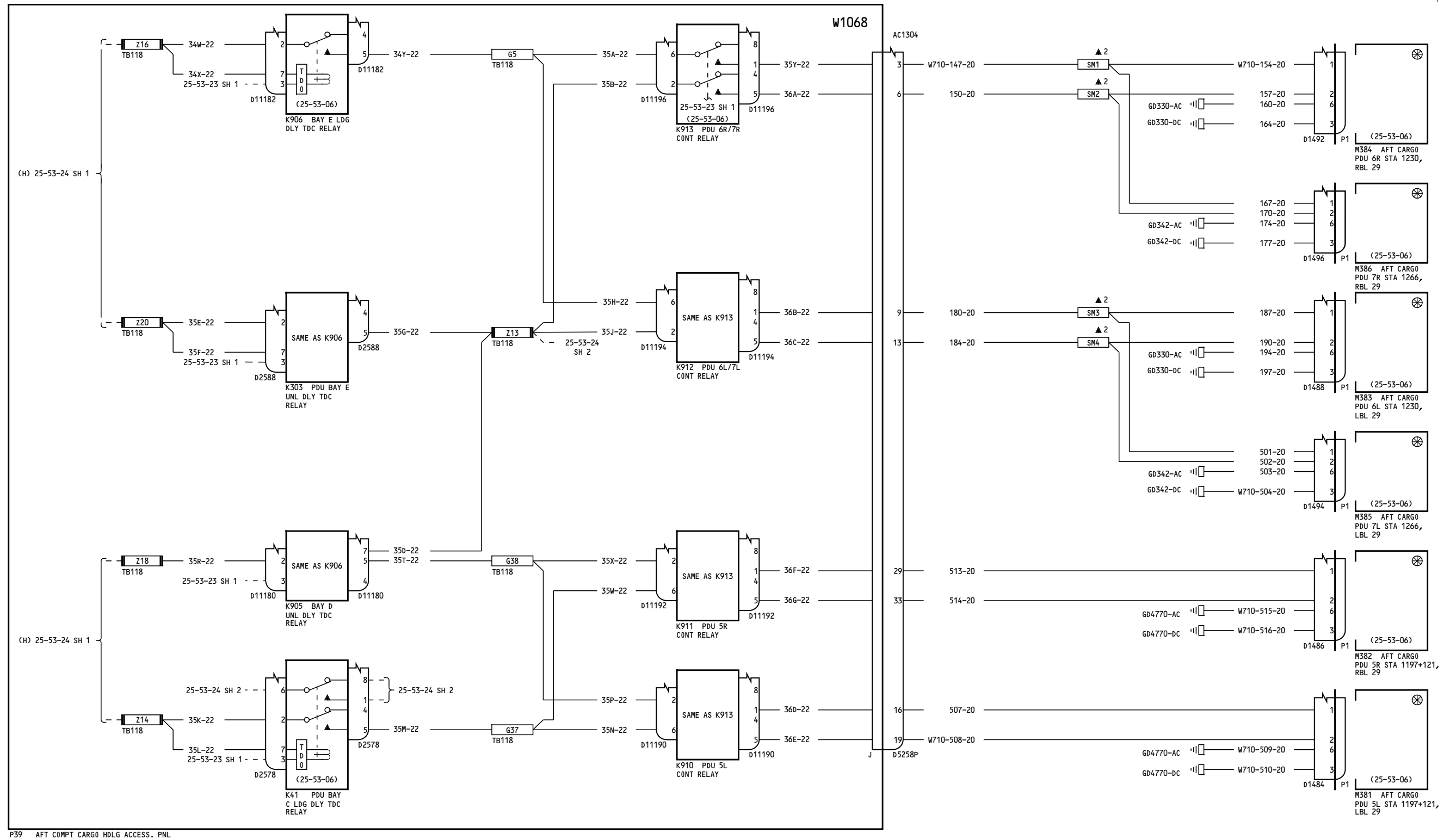

P39 AFT COMPT CARGO HDLG ACCESS. PNL

150-199, 275-299

CARGO HANDLING-
AFT LOWER LOBE PDU
LOAD/UNLOAD CONTROL

25-53-24

Page 2
Sheet 3
Jan 21/2005

D280T132

25-53-24

Page 2
Sheet 3
Jan 21/2005

13

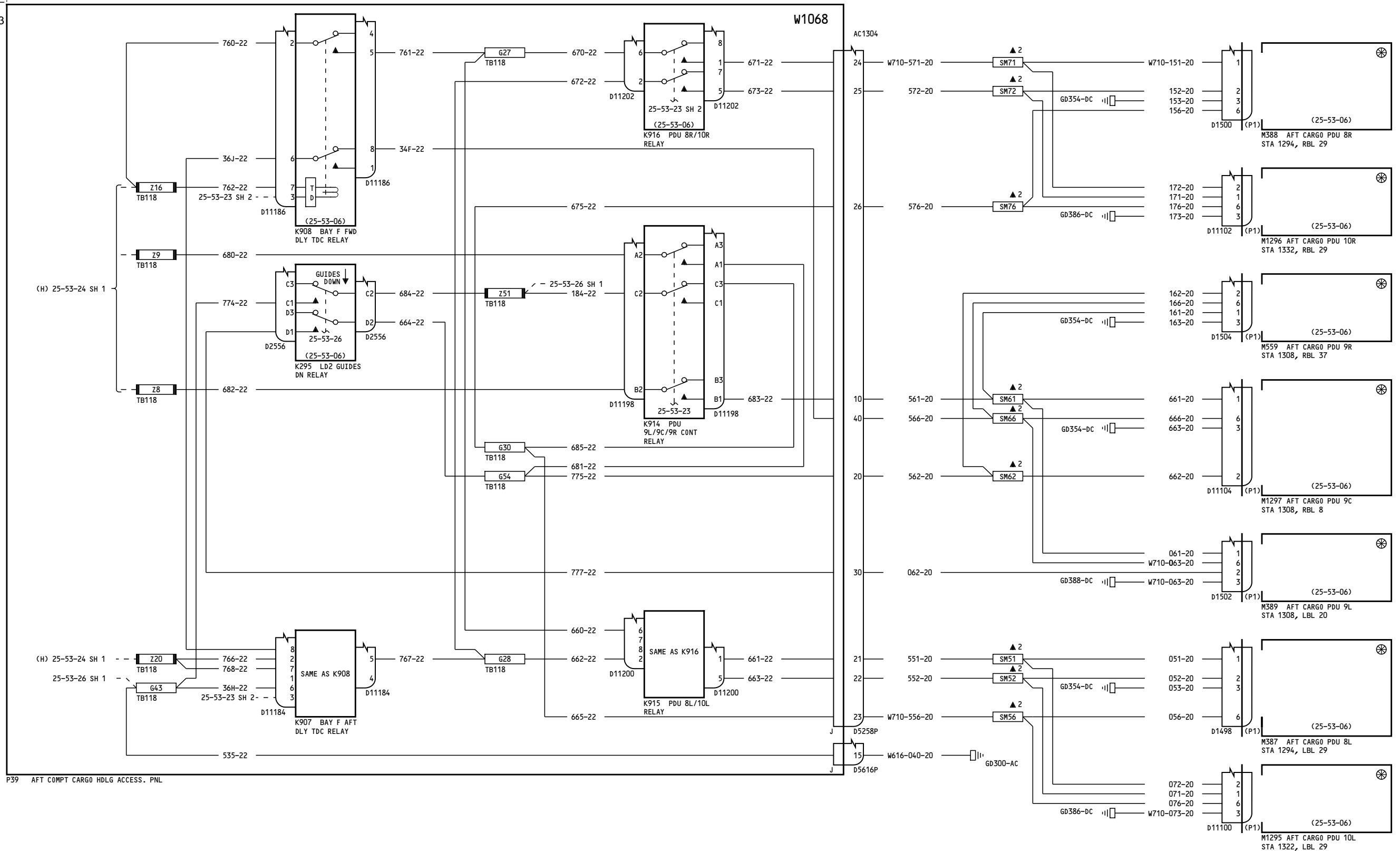

P39 AFT COMPT CARGO HDLG ACCESS. PNL

150-199, 275-299

CARGO HANDLING-
AFT LOWER LOBE PDU
LOAD/UNLOAD CONTROL

D280T132

25-53-24

Page 2
Sheet 4
Jan 21/2005

25-53-24

Page 2
Sheet 4
Jan 21/2005

13

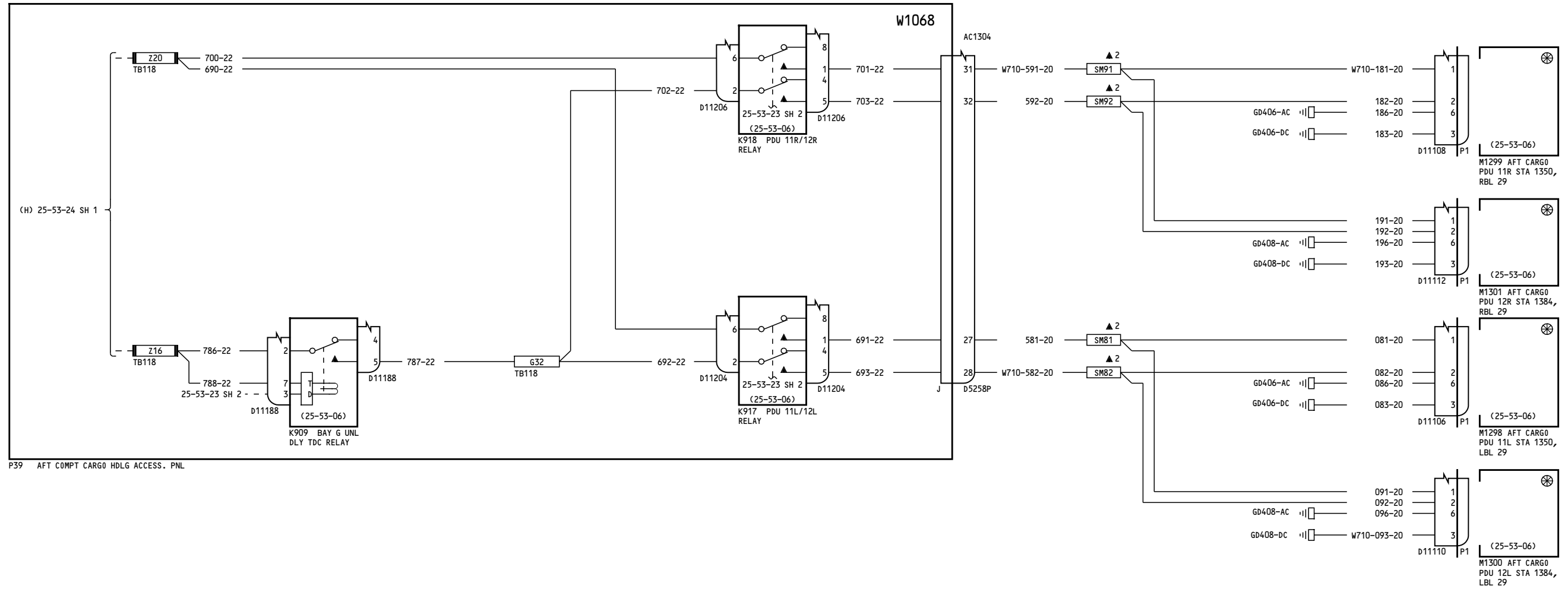

150-199, 275-299

**CARGO HANDLING-
AFT LOWER LOBE PDU
LOAD/UNLOAD CONTROL**

D280T132

25-53-24

Page 2
Sheet 5
Jan 21/2005

25-53-24

Page 2
Sheet 5
Jan 21/2005

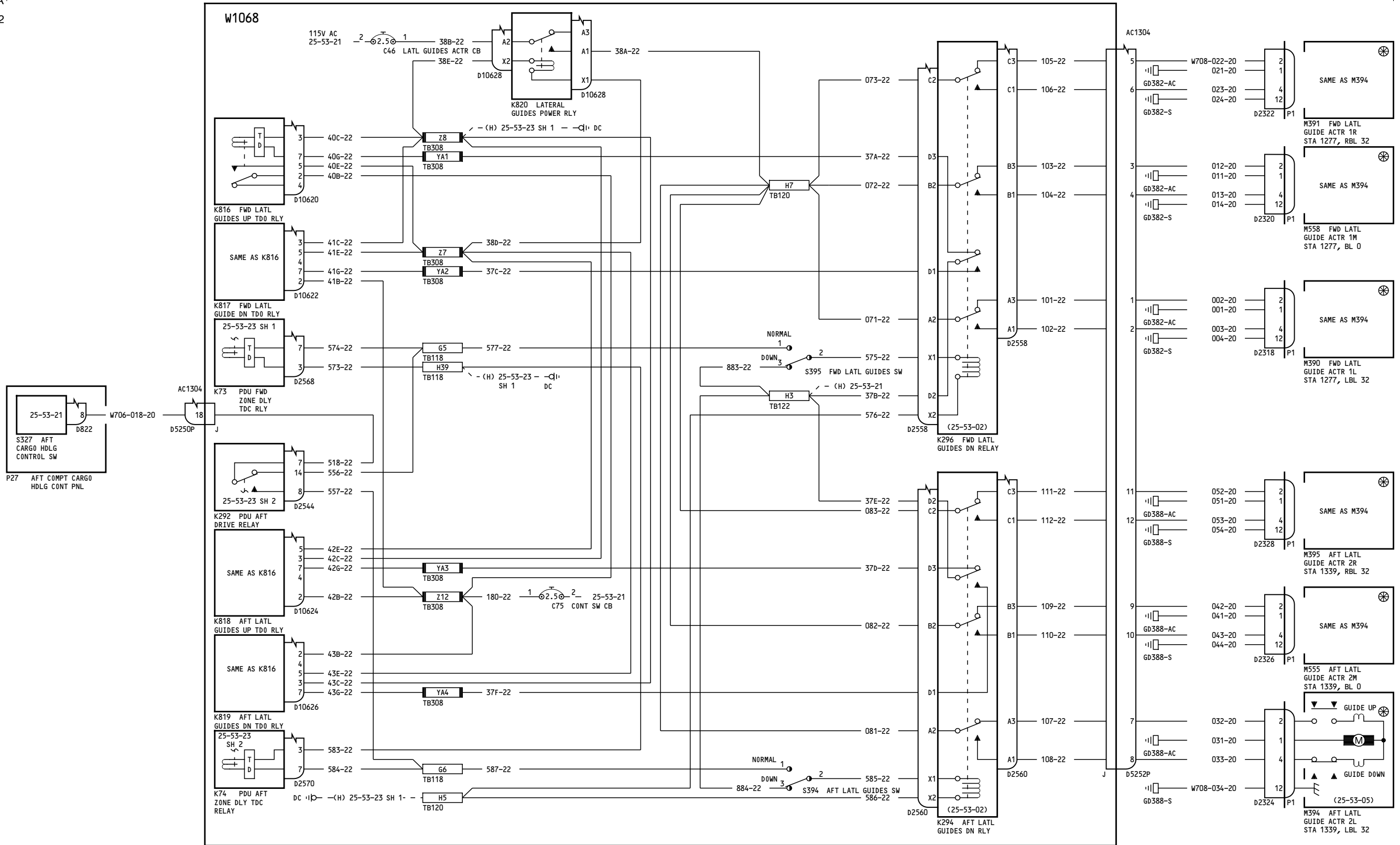

050-099

**CARGO HANDLING-
AFT LOWER LOBE
LATERAL GUIDES**

D280T132

25-53-25

Page 1

Jan 21/2005

25-53-25

Page 1

Jan 21/2005

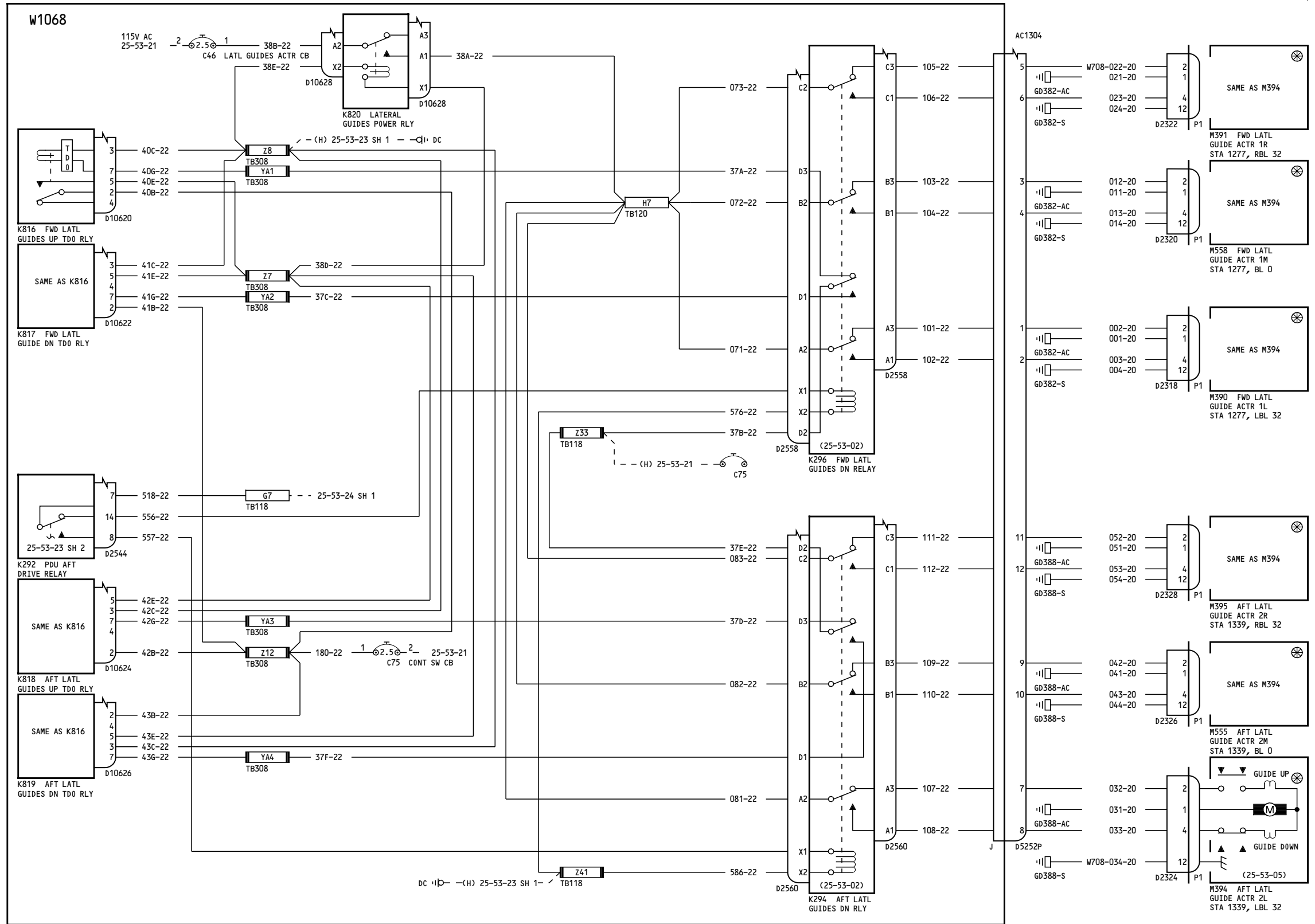

150-199, 275-278

**CARGO HANDLING-
AFT LOWER LOBE
LATERAL GUIDES**

25-53-25

Page 2

Jan 21/2005

D280T132

25-53-25

Page 2

Jan 21/2005

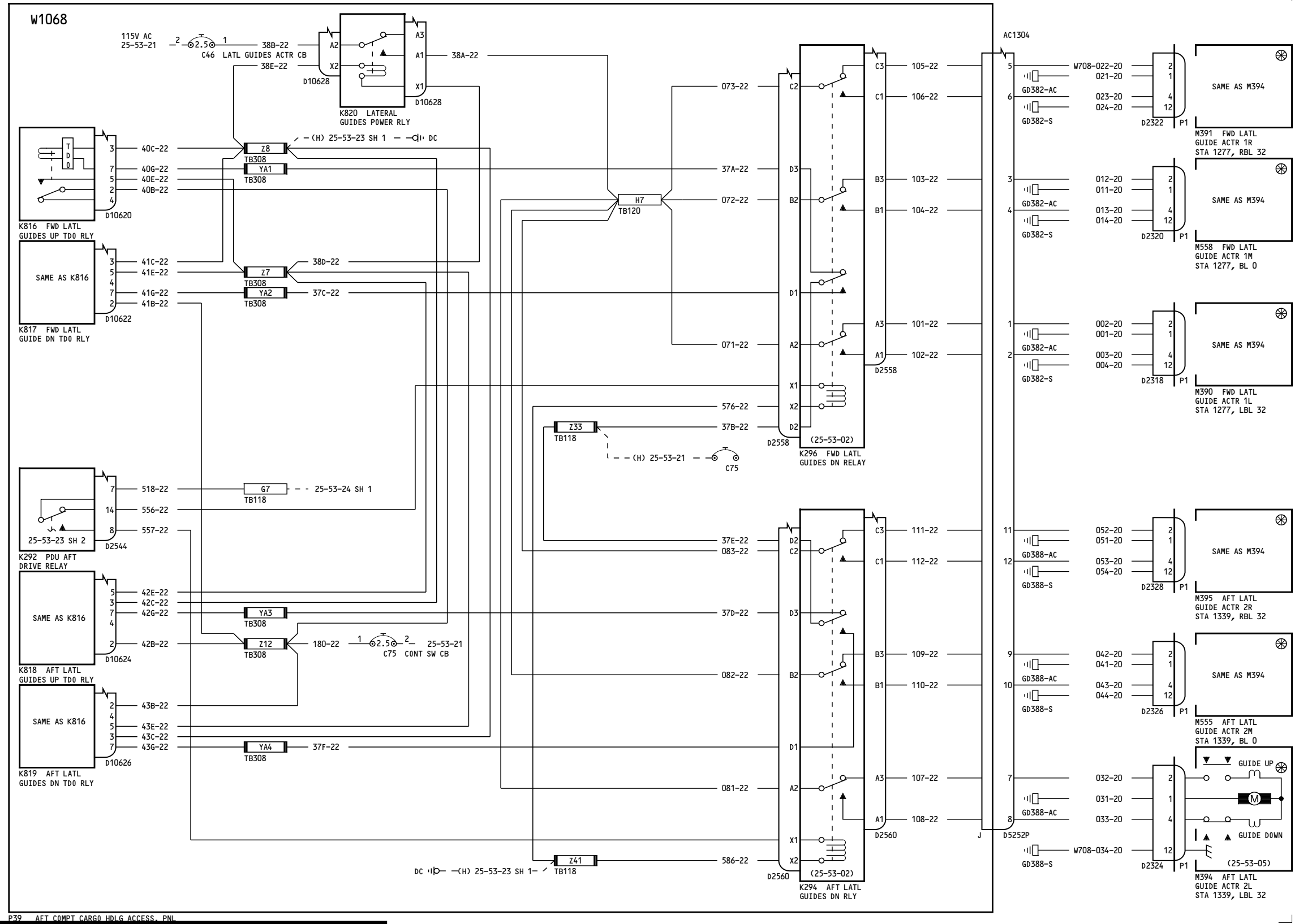

280-299

**CARGO HANDLING-
AFT LOWER LOBE
LATERAL GUIDES**

D280T132

25-53-25

Page 3

Jan 21/2005

25-53-25

Page 3

Jan 21/2005

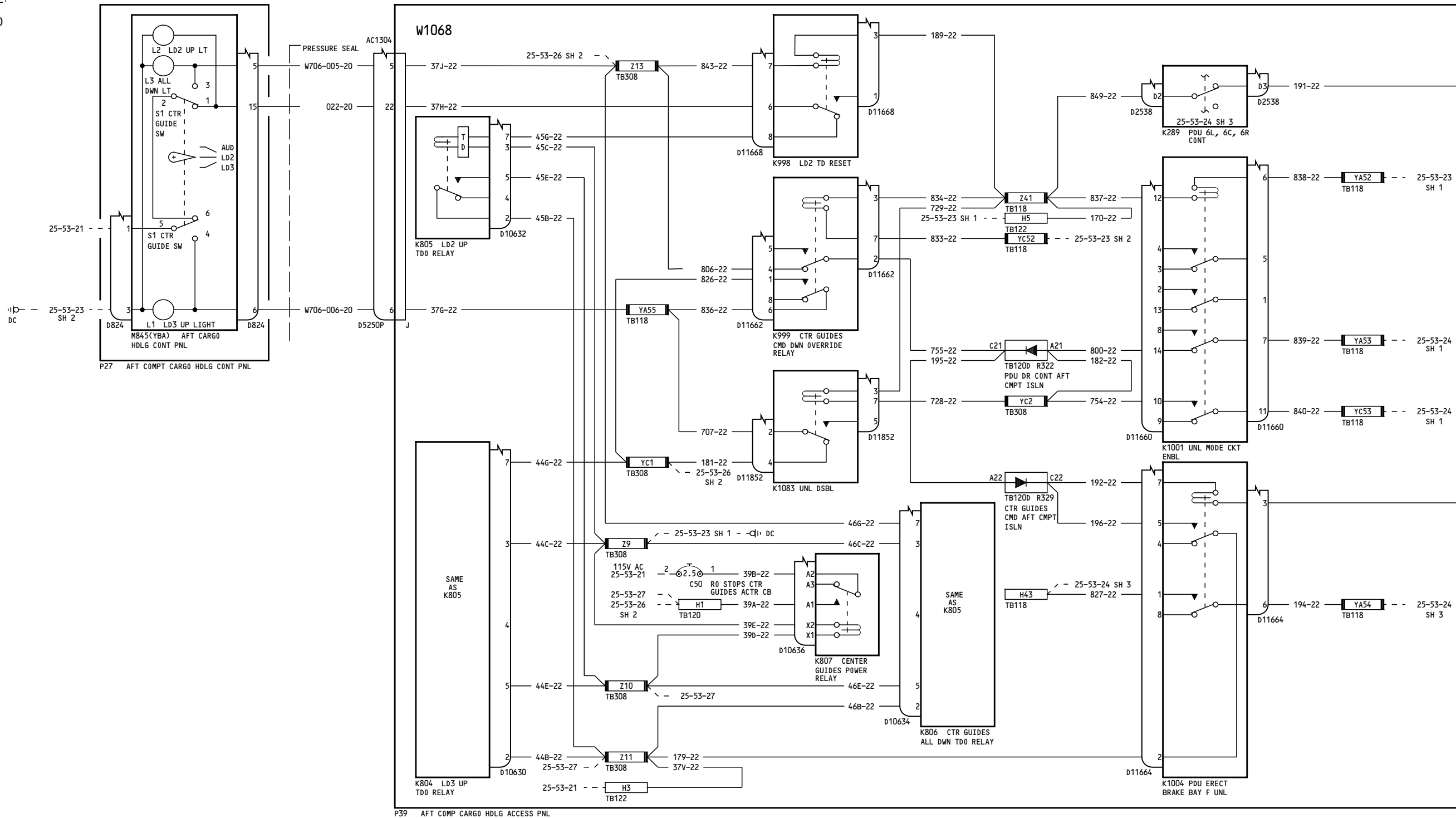

050-099

**CARGO HANDLING-
AFT LOWER LOBE
CENTER GUIDES**

D280T132

25-53-26

Page 1
Sheet 1
Jan 21/2005

25-53-26

Page 1
Sheet 1
Jan 21/2005

20

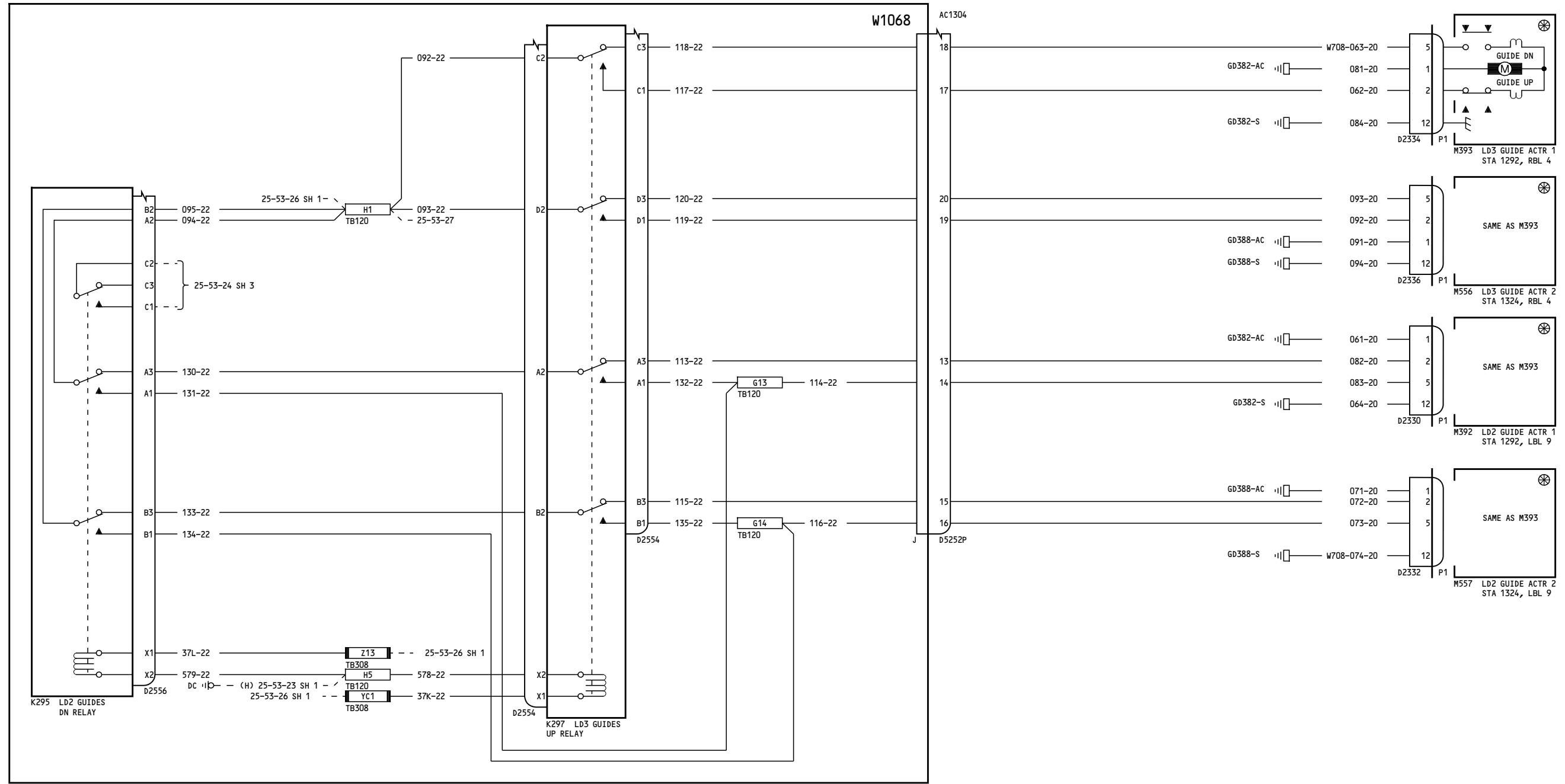

P39 AFT COMPT CARGO HDLG ACCESS PNL

050-099

CARGO HANDLING-
AFT LOWER LOBE
CENTER GUIDES

D280T132

25-53-26

Page 1
Sheet 2
Jan 21/2005

25-53-26

Page 1
Sheet 2
Jan 21/2005

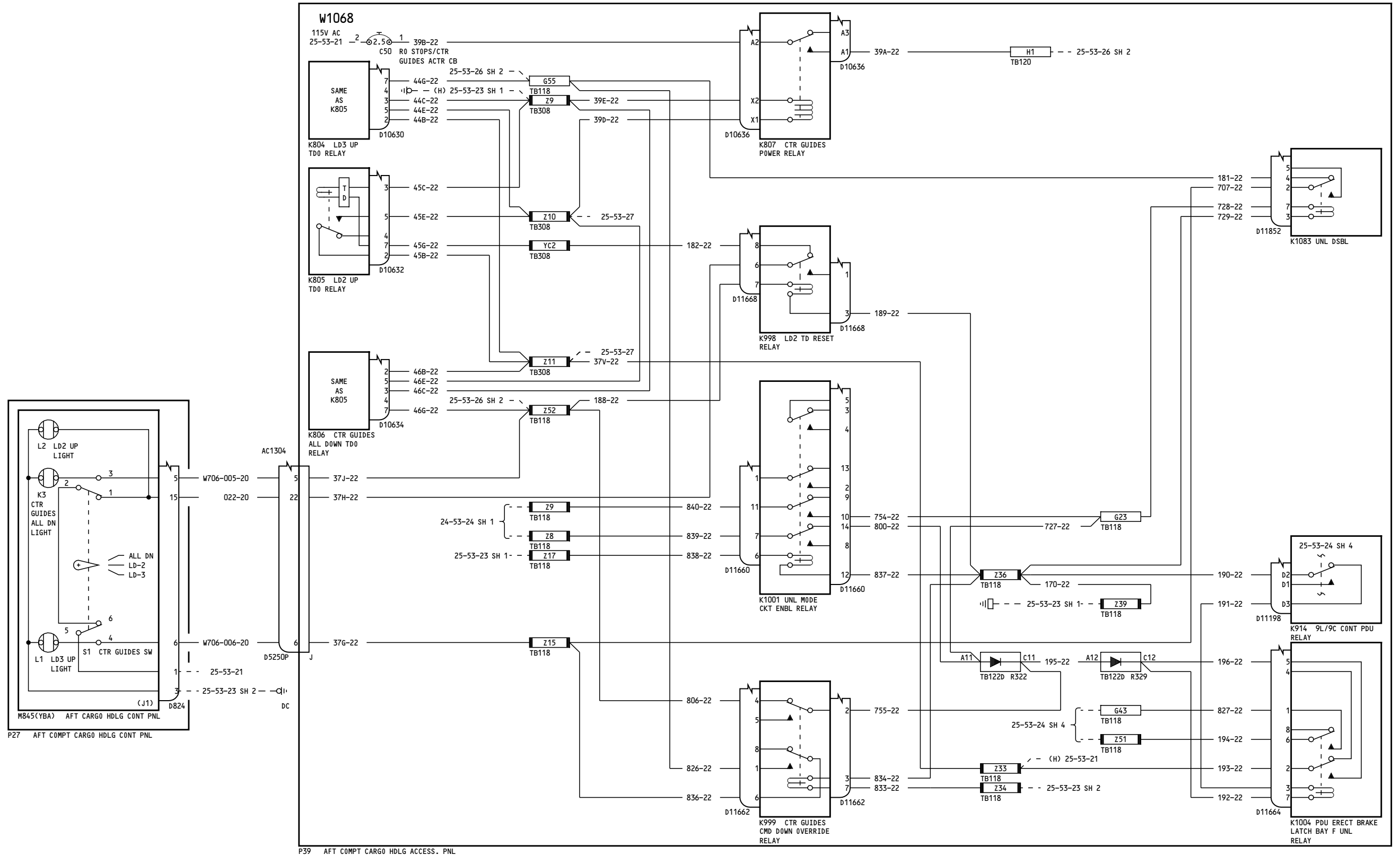

150-199

**CARGO HANDLING-
AFT LOWER LOBE
CENTER GUIDES**

25-53-26

Page 2
Sheet 1
Jan 21/2005

D280T132

25-53-26

Page 2
Sheet 1
Jan 21/2005

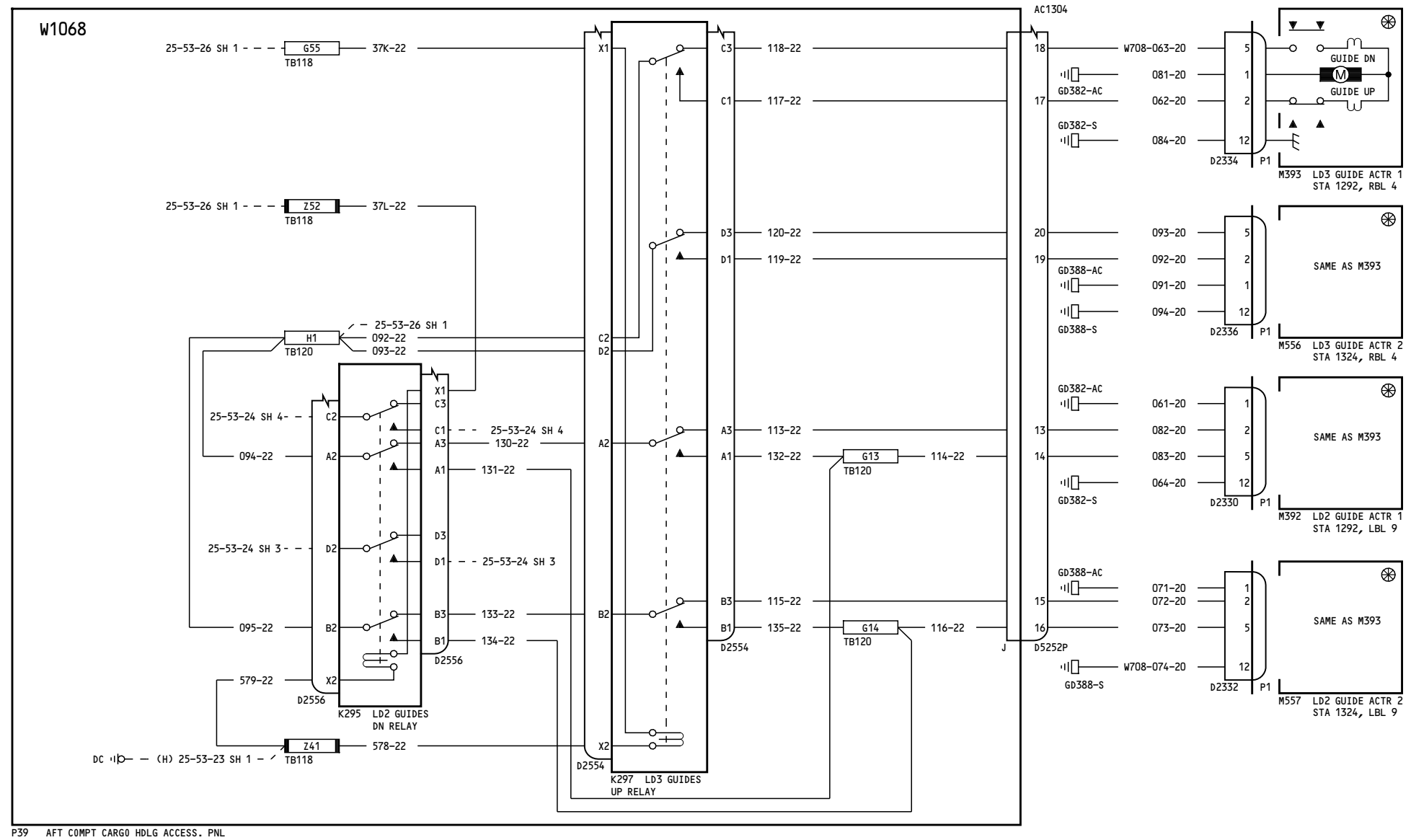

P39 AFT COMPT CARGO HDLG ACCESS. PNL

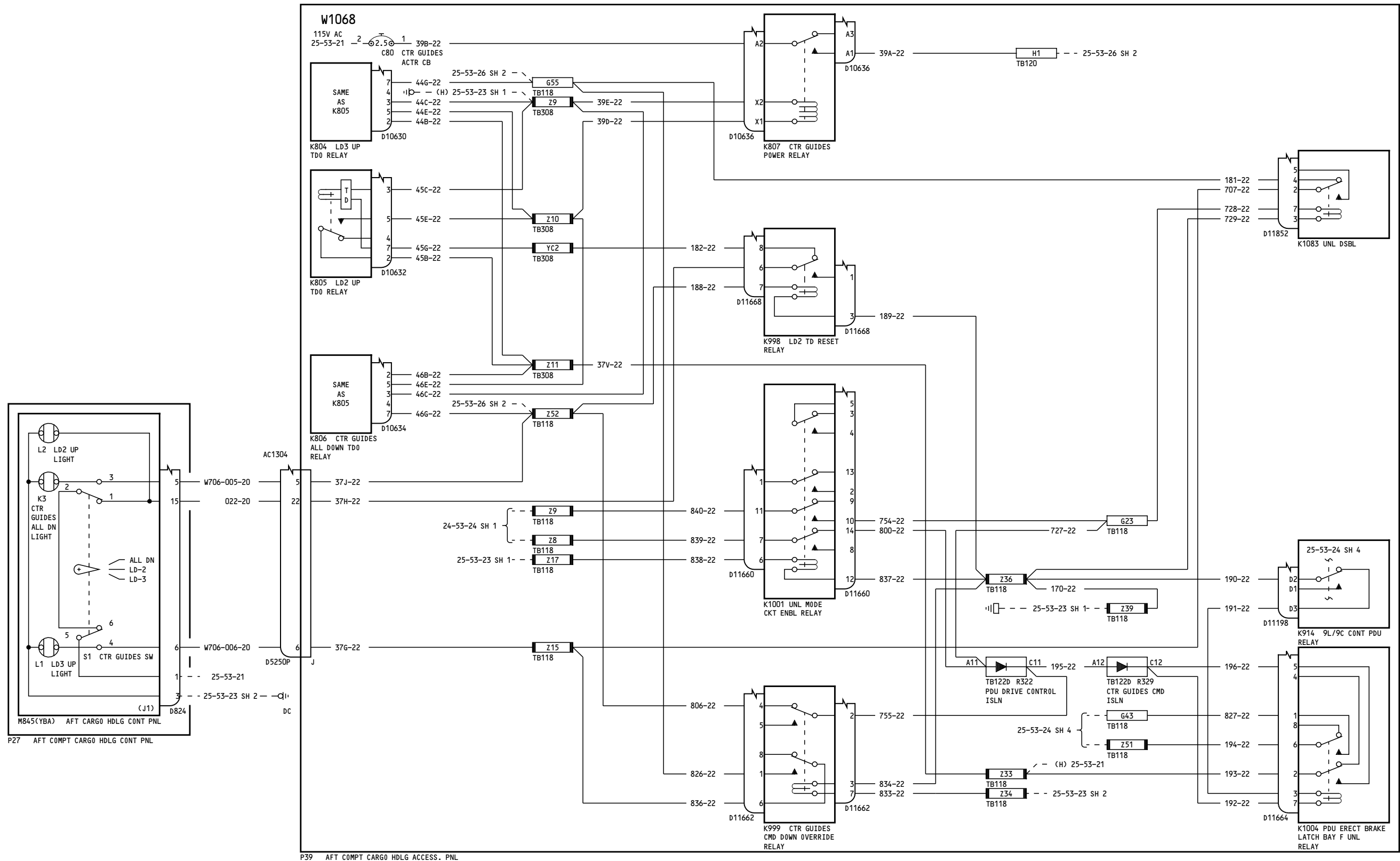

275-299

**CARGO HANDLING-
 AFT LOWER LOBE
 CENTER GUIDES**

D280T132

25-53-26

Page 3
 Sheet 1
 Jan 21/2005

25-53-26

Page 3
 Sheet 1
 Jan 21/2005

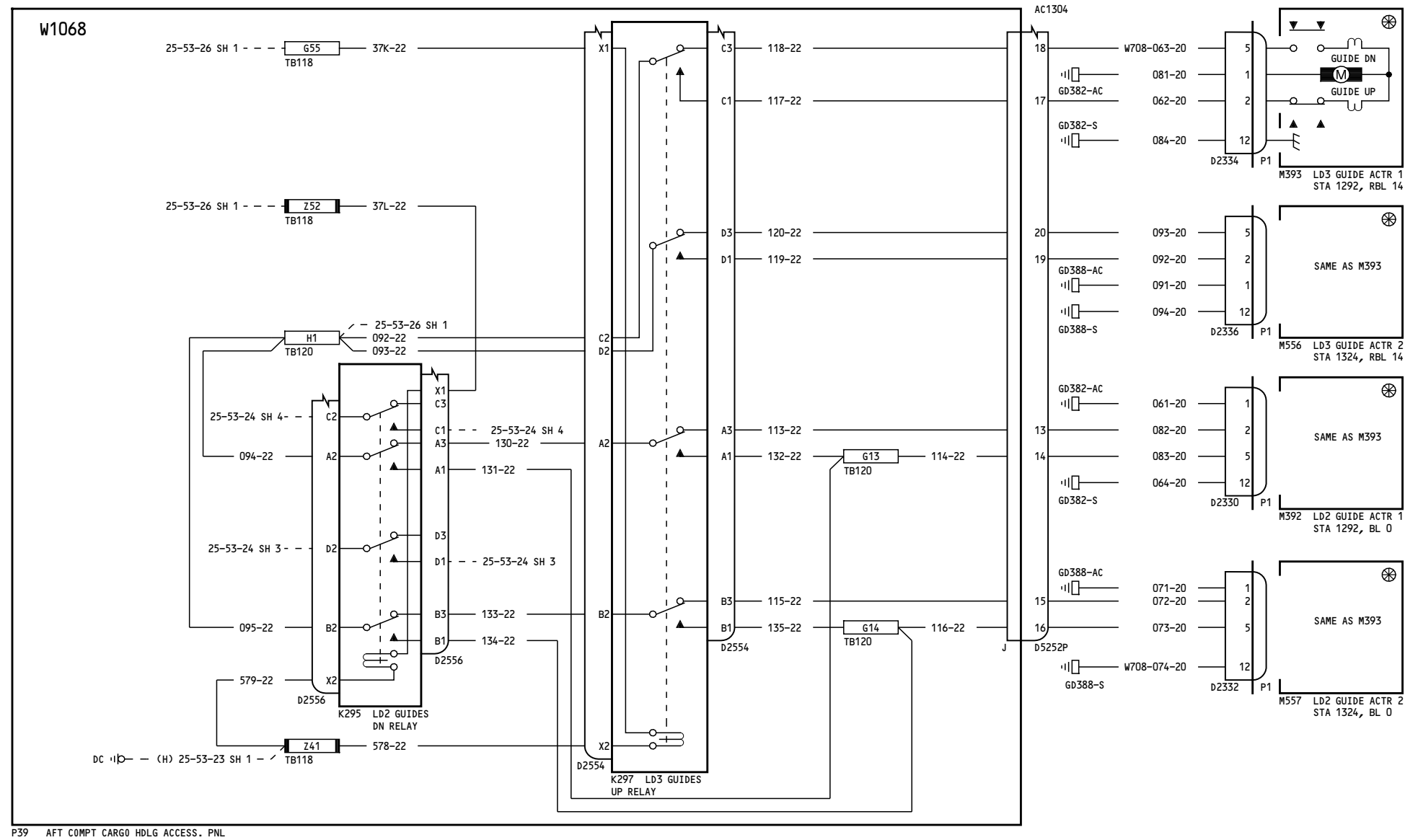

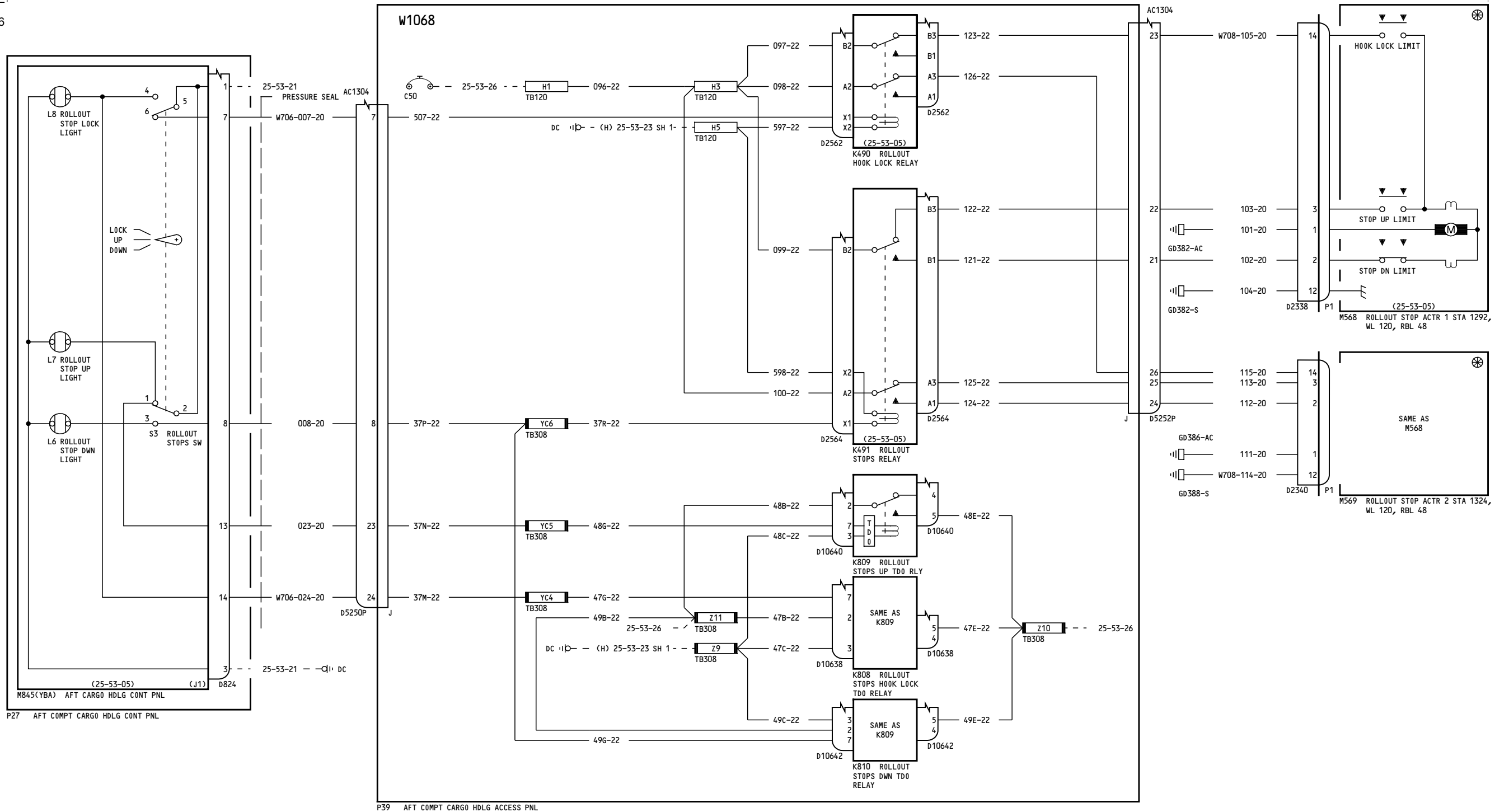

050-099

**CARGO HANDLING-
AFT LOWER LOBE
ROLLOUT STOPS**

25-53-27

Page 1

D280T132

Jan 21/2005

25-53-27

Page 1

Jan 21/2005

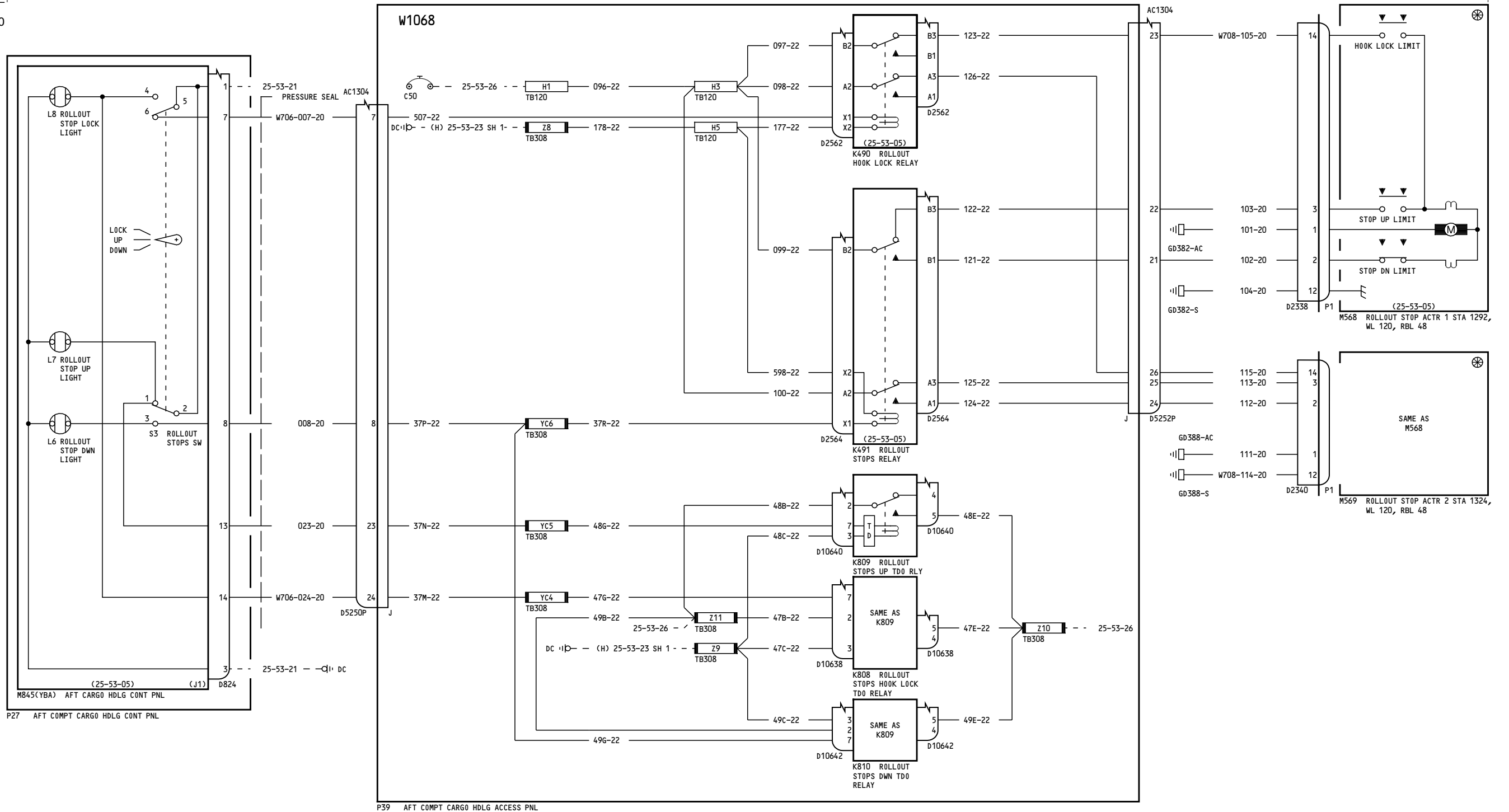

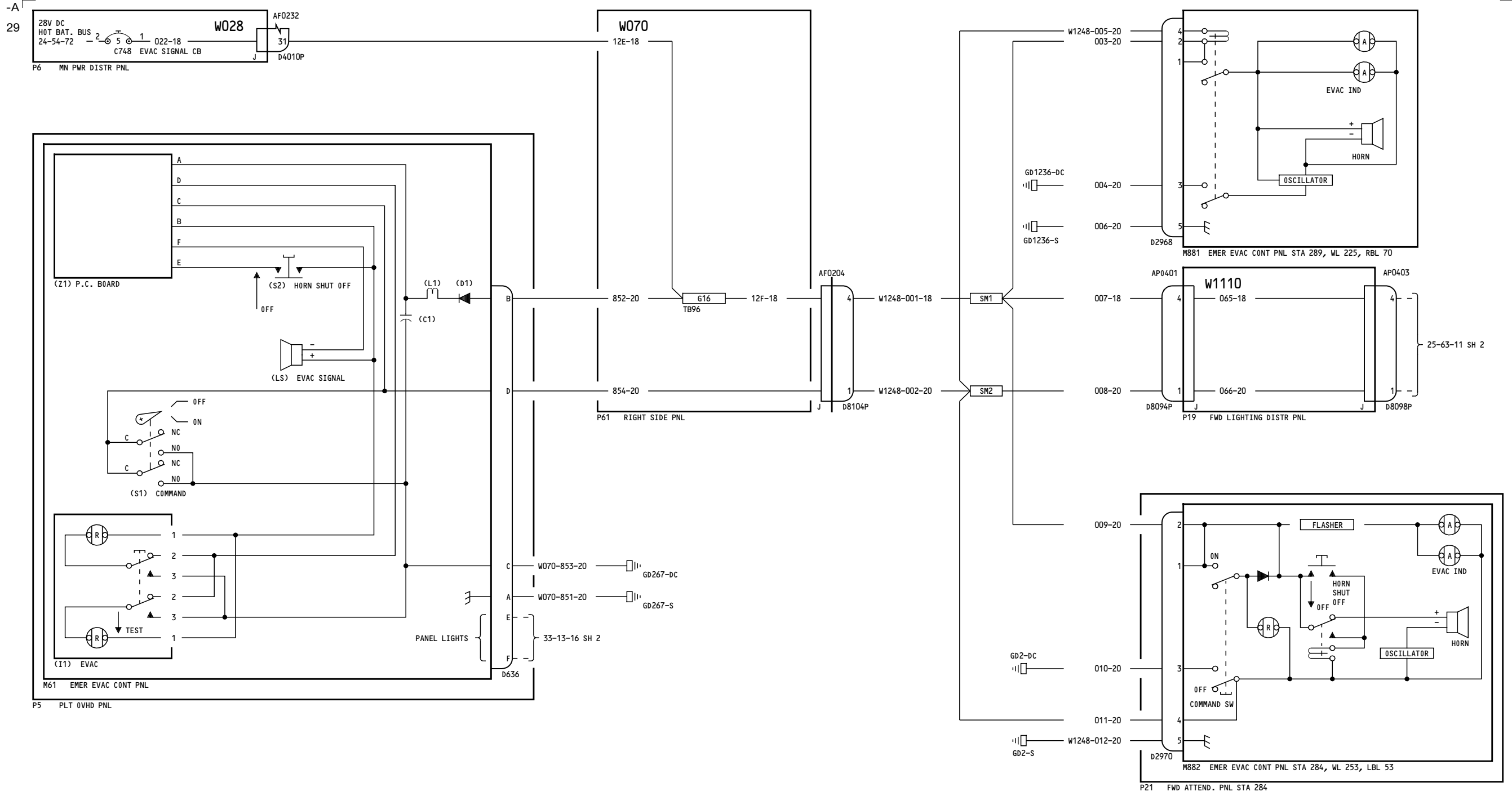

050-099

**EMERGENCY EVACUATION
SIGNAL SYSTEM CONTROL**

25-63-11

Page 1
Sheet 1
Jan 21/2005

D280T132

25-63-11

Page 1
Sheet 1
Jan 21/2005

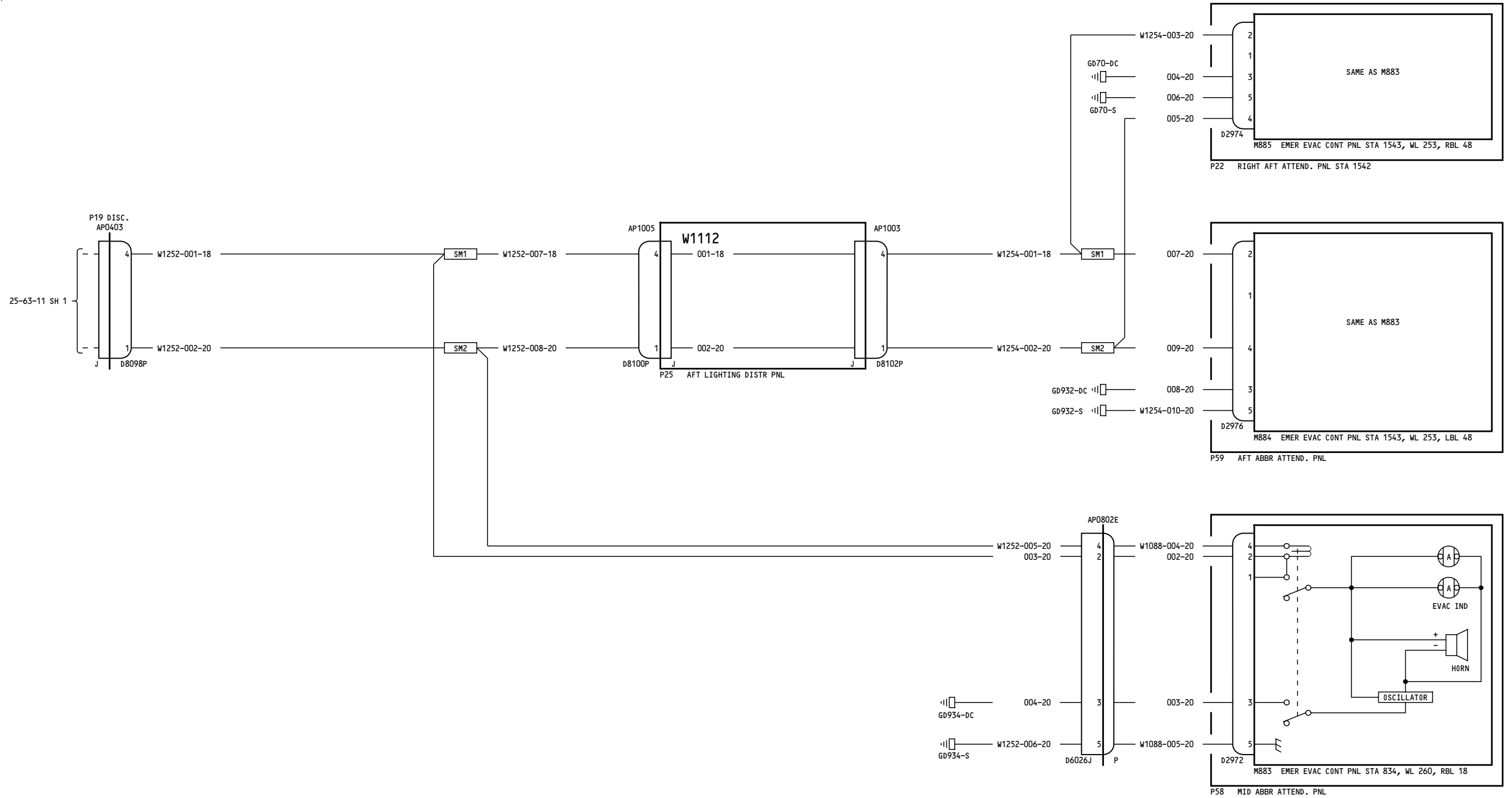

050-099

**EMERGENCY EVACUATION
SIGNAL SYSTEM CONTROL**

25-63-11

Page 1
Sheet 2
Jan 21/2005

D280T132

25-63-11

Page 1
Sheet 2
Jan 21/2005

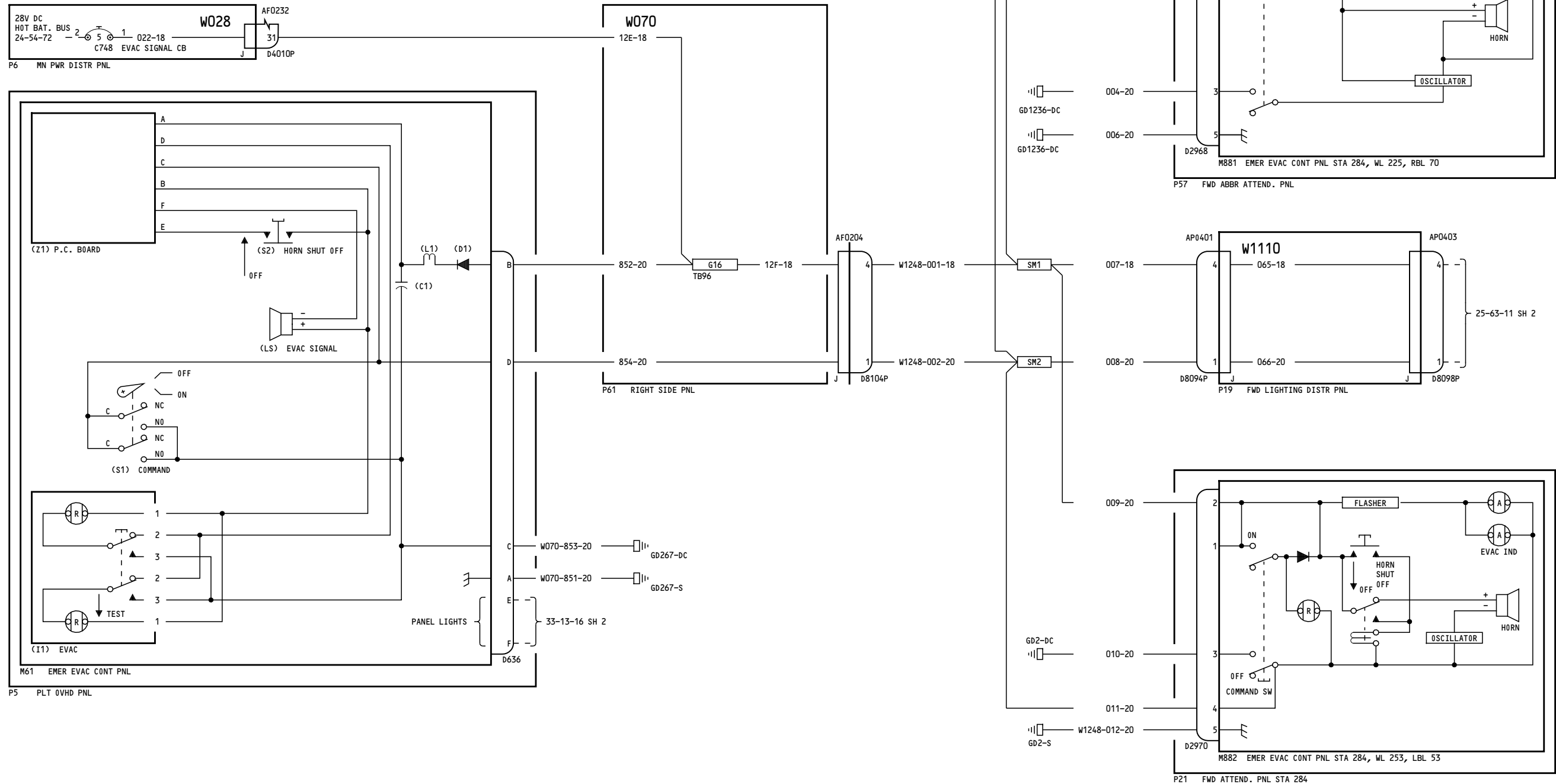

150-199

**EMERGENCY EVACUATION
SIGNAL SYSTEM CONTROL**

25-63-11

Page 2
Sheet 1
Jan 21/2005

D280T132

25-63-11

Page 2
Sheet 1
Jan 21/2005

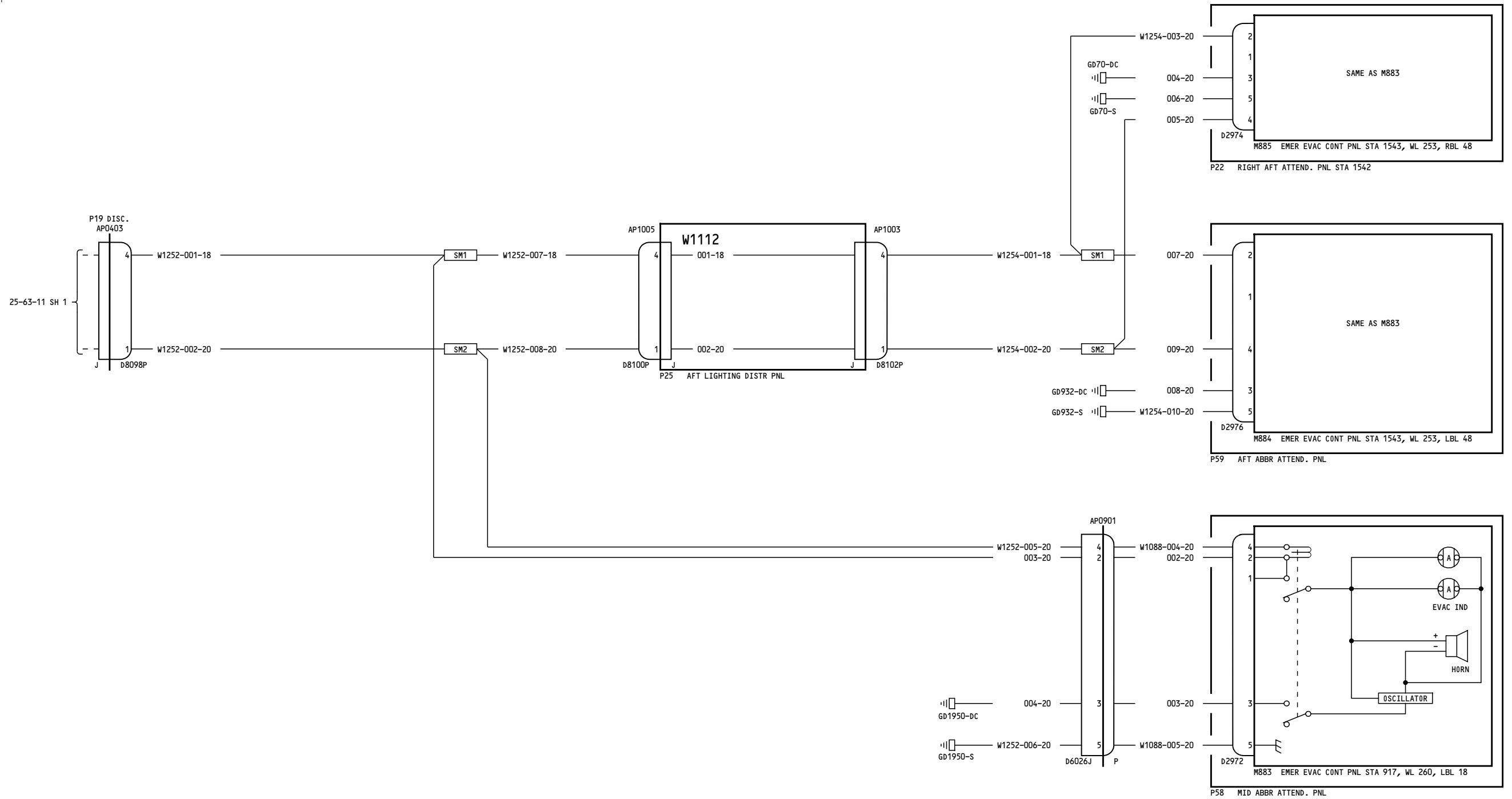

-A
26

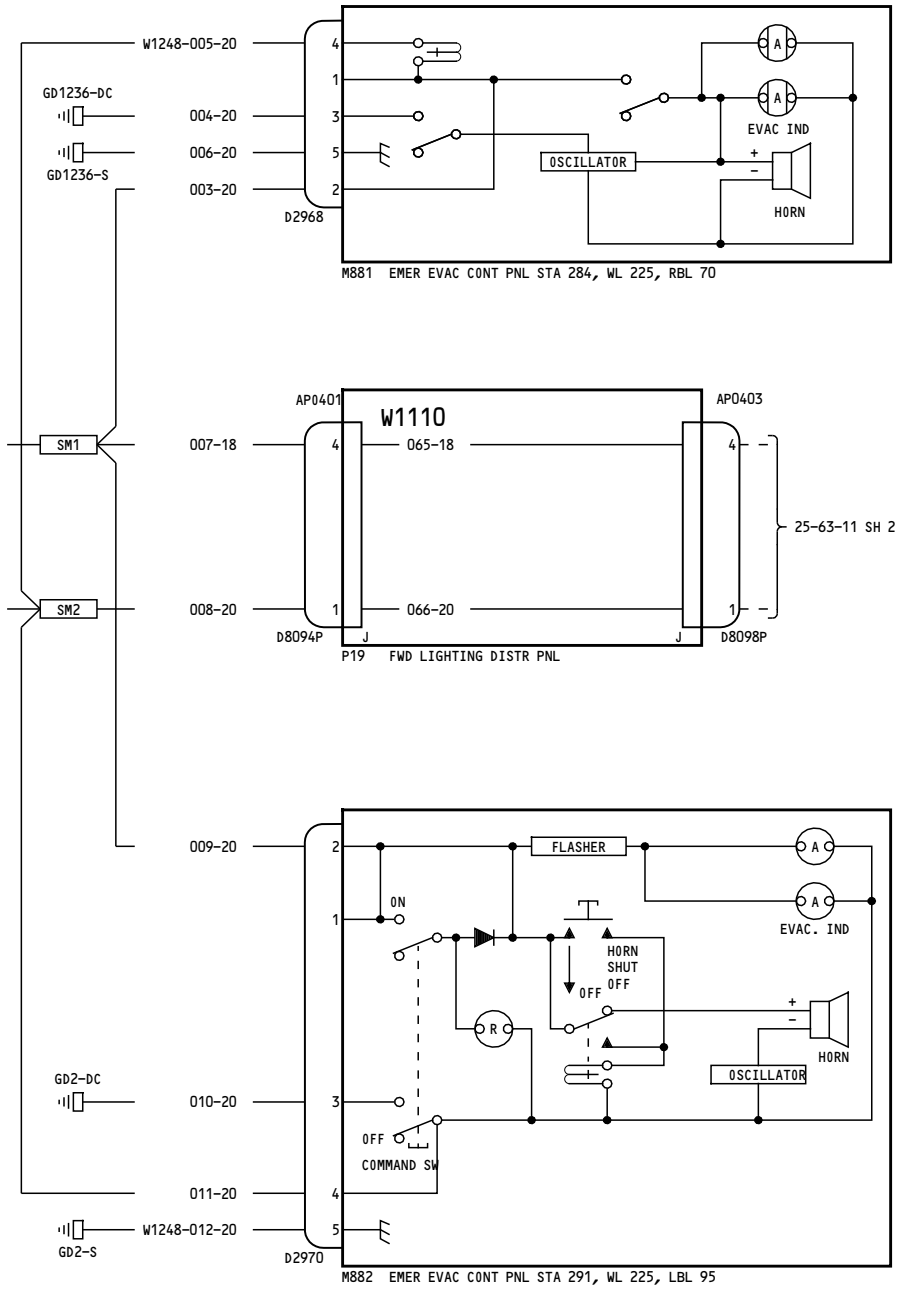
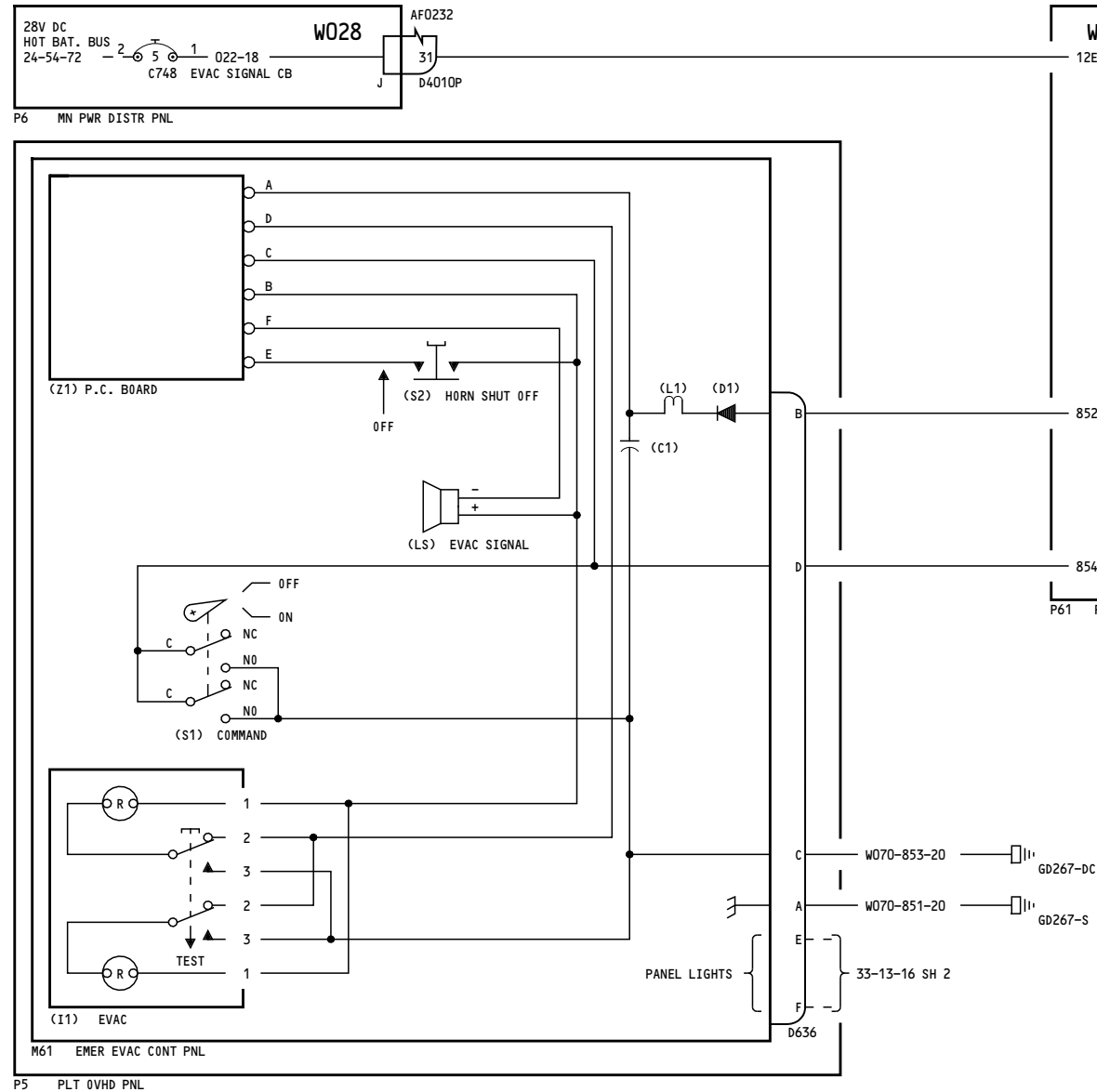

275-299

**EMERGENCY EVACUATION
SIGNAL SYSTEM CONTROL**

25-63-11

Page 3
Sheet 1
Jan 21/2005

D280T132

25-63-11

Page 3
Sheet 1
Jan 21/2005

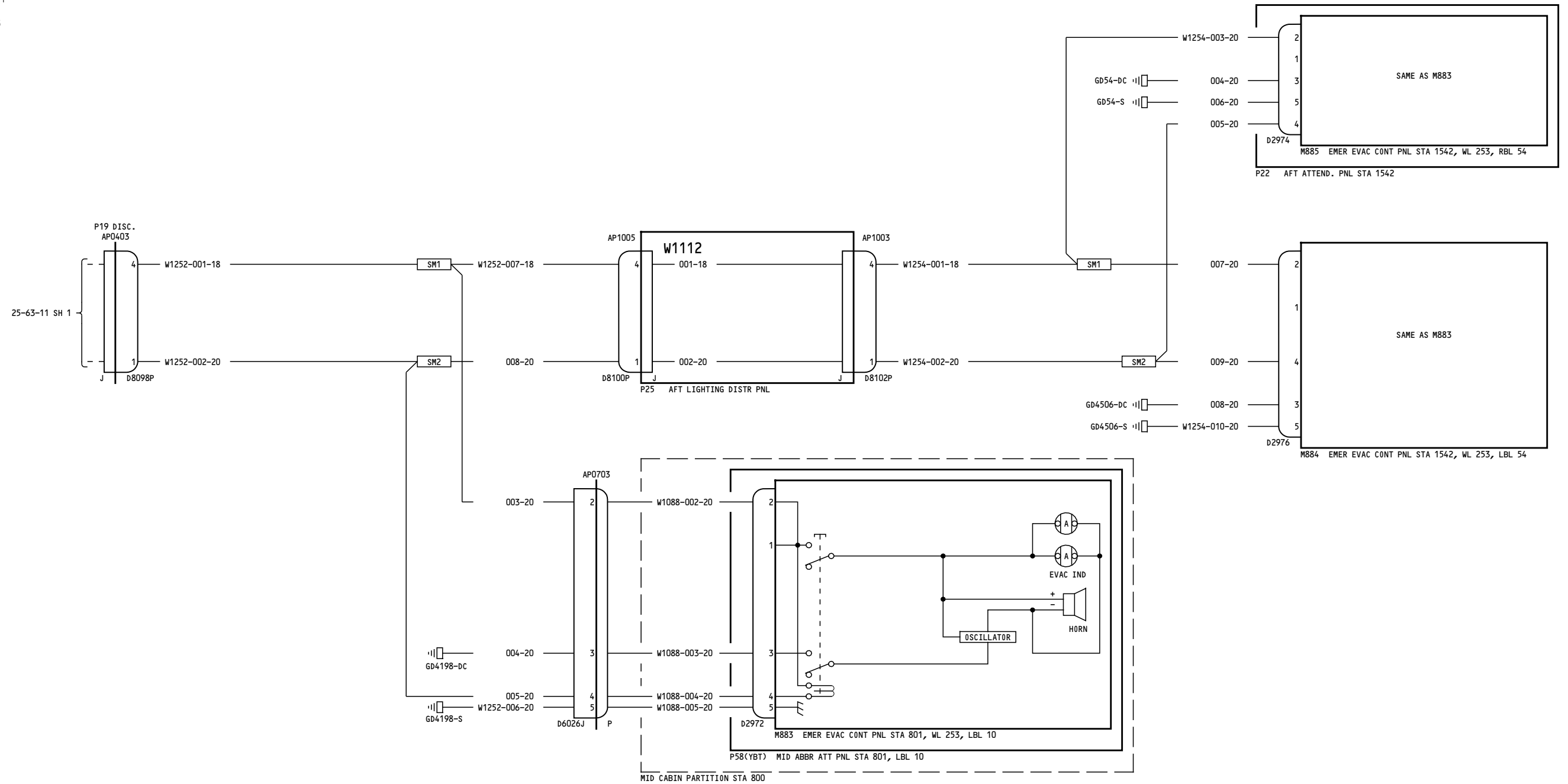

275-299

**EMERGENCY EVACUATION
SIGNAL SYSTEM CONTROL**

25-63-11

Page 3
Sheet 2
Jan 21/2005

D280T132

25-63-11

Page 3
Sheet 2
Jan 21/2005

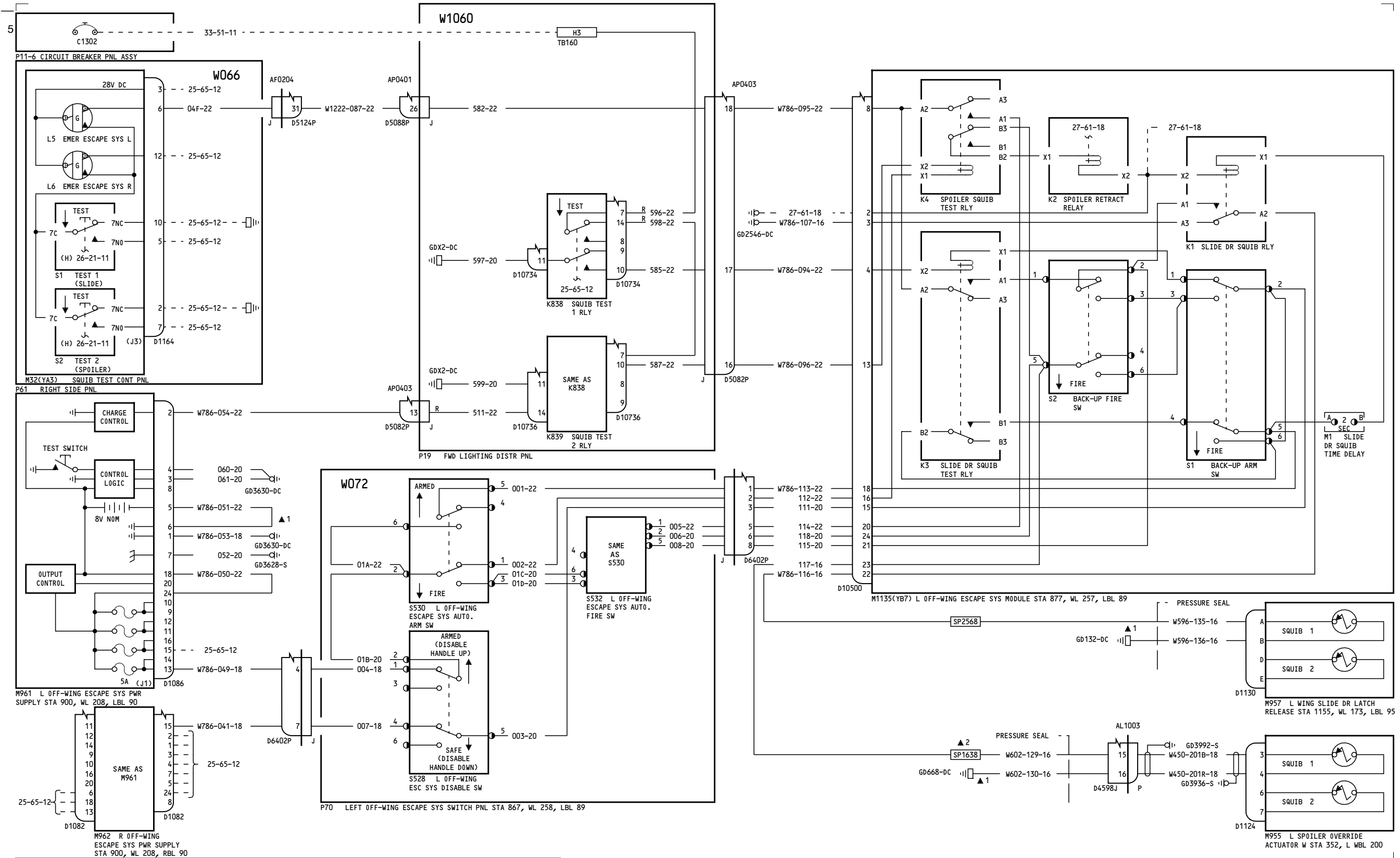

050-099

LEFT OFF-WING ESCAPE SYSTEM

25-65-11

Page 1

D280T132

Jan 21/2005

25-65-11

Page 1

Jan 21/2005

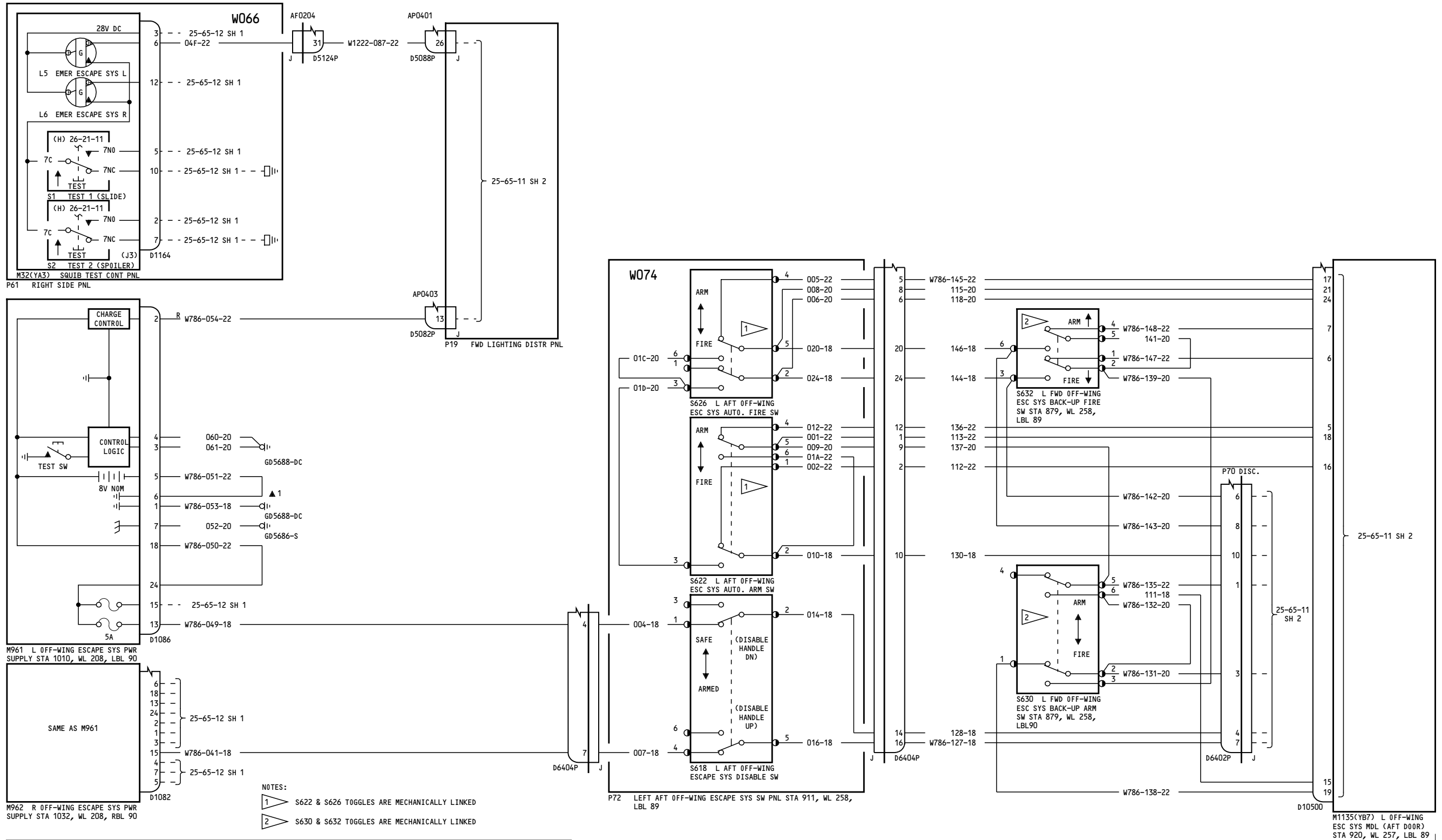

150-199

LEFT OFF-WING ESCAPE SYSTEM

D280T132

25-65-11

25-65-11

11

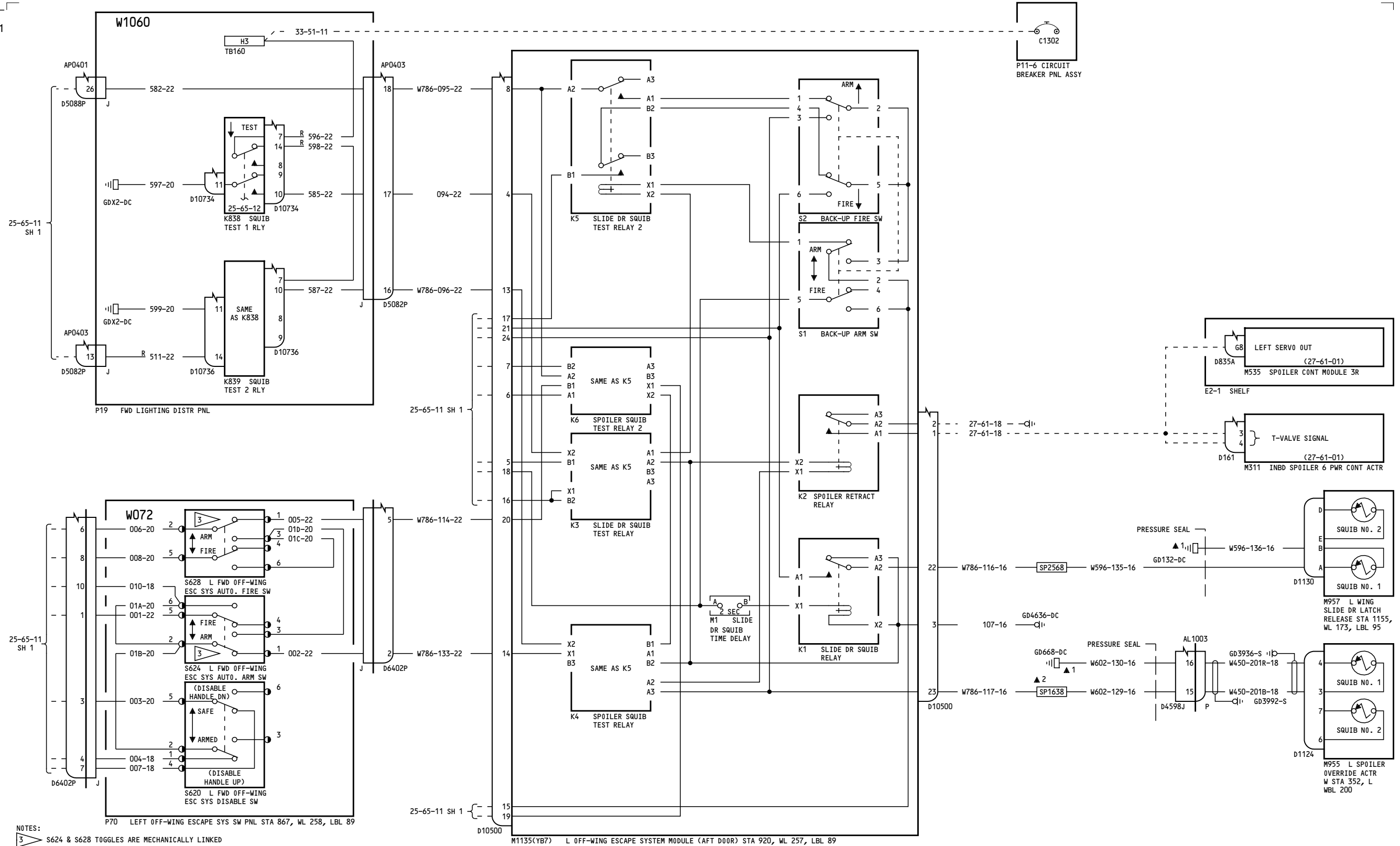

NOTES:
 3 S624 & S628 TOGGLES ARE MECHANICALLY LINKED

150-199

LEFT OFF-WING ESCAPE SYSTEM

25-65-11

Page 2
 Sheet 2
 Jan 21/2005

D280T132

25-65-11

Page 2
 Sheet 2
 Jan 21/2005

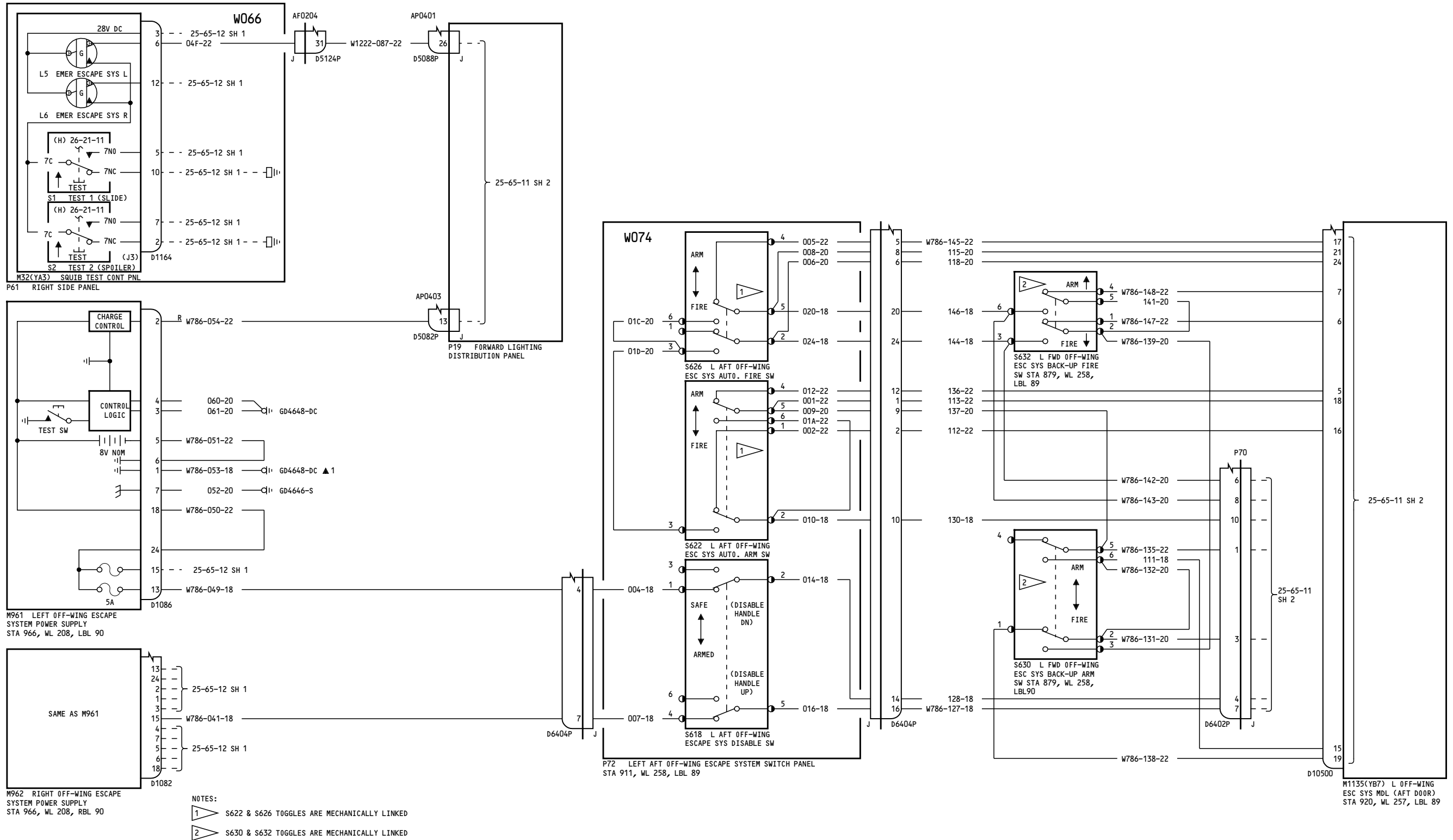

275-299

LEFT OFF-WING ESCAPE SYSTEM

25-65-11

Page 3
Sheet 1
Jan 21/2005

D280T132

25-65-11

Page 3
Sheet 1
Jan 21/2005

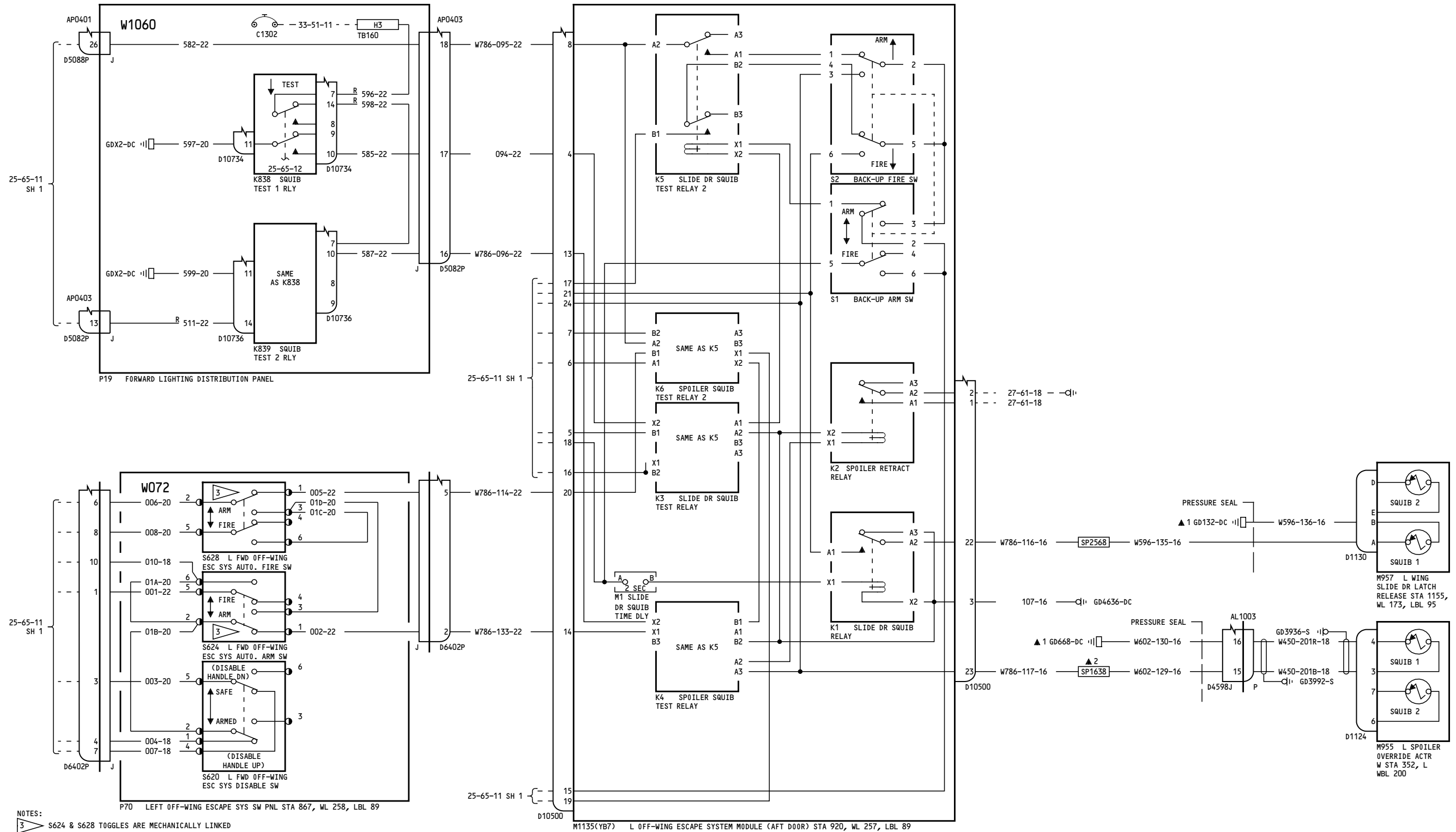

NOTES:
 3 S624 & S628 TOGGLES ARE MECHANICALLY LINKED

275-299

LEFT OFF-WING ESCAPE SYSTEM

D280T132

25-65-11

Page 3
Sheet 2
Jan 21/2005

25-65-11

Page 3
Sheet 2
Jan 21/2005

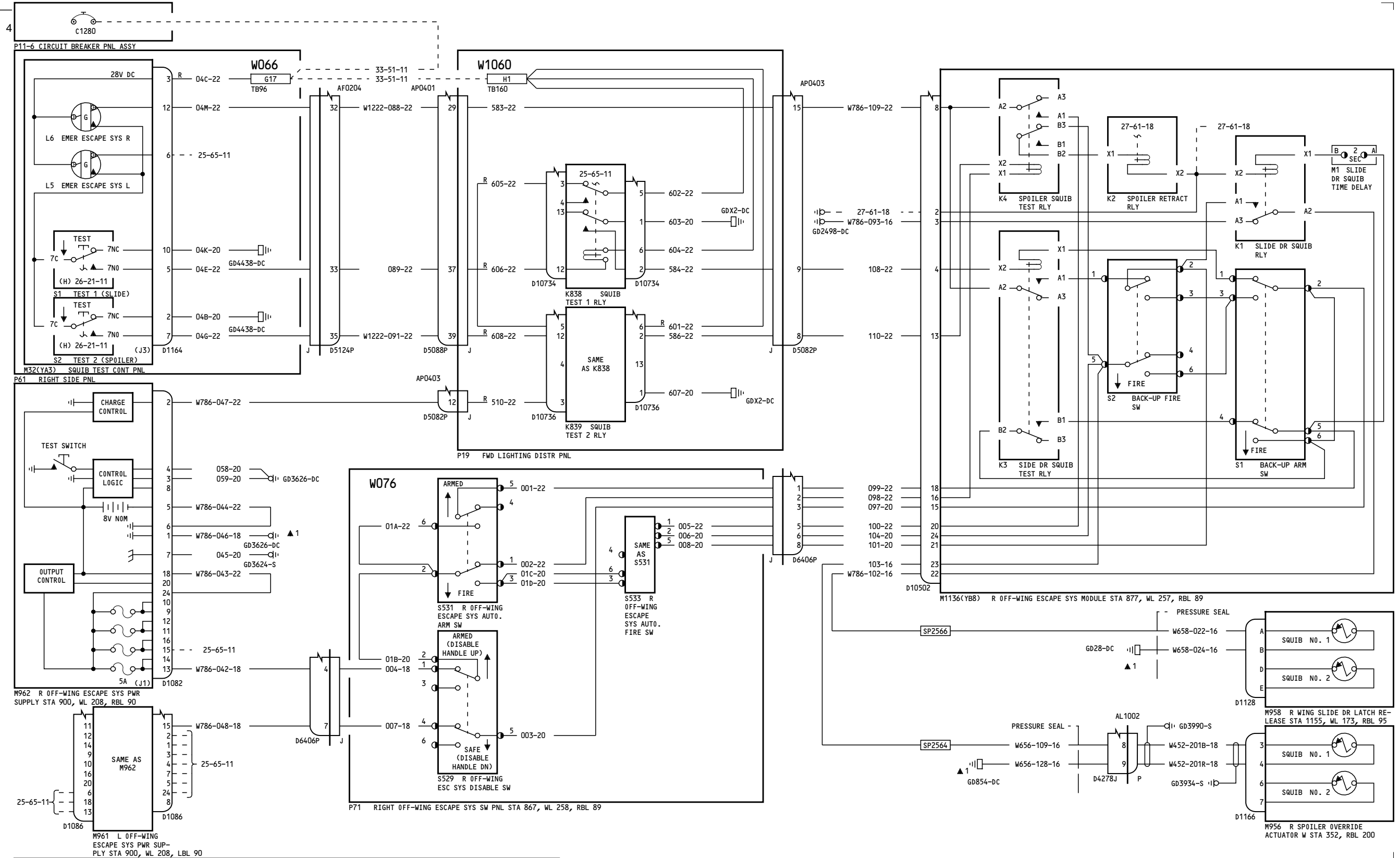

050-099

RIGHT OFF-WING ESCAPE SYSTEM

25-65-12

Page 1

D280T132

Jan 21/2005

25-65-12

Page 1

Jan 21/2005

BOEING PROPRIETARY - Copyright © - Unpublished Work - See title page for details.

25-65-12

Page 1

Jan 21/2005

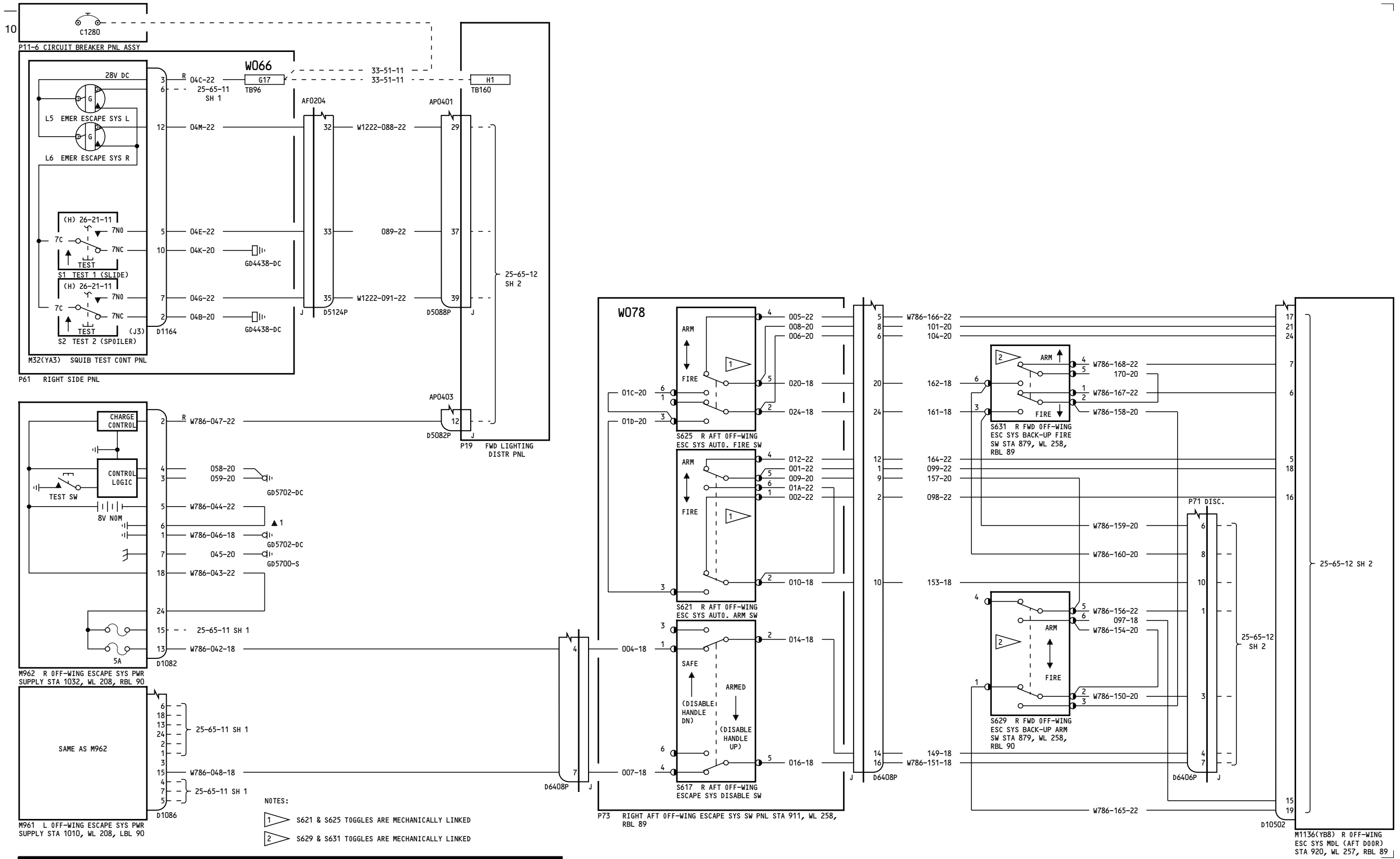

150-199

RIGHT OFF-WING ESCAPE SYSTEM

D280T132

25-65-12

25-65-12

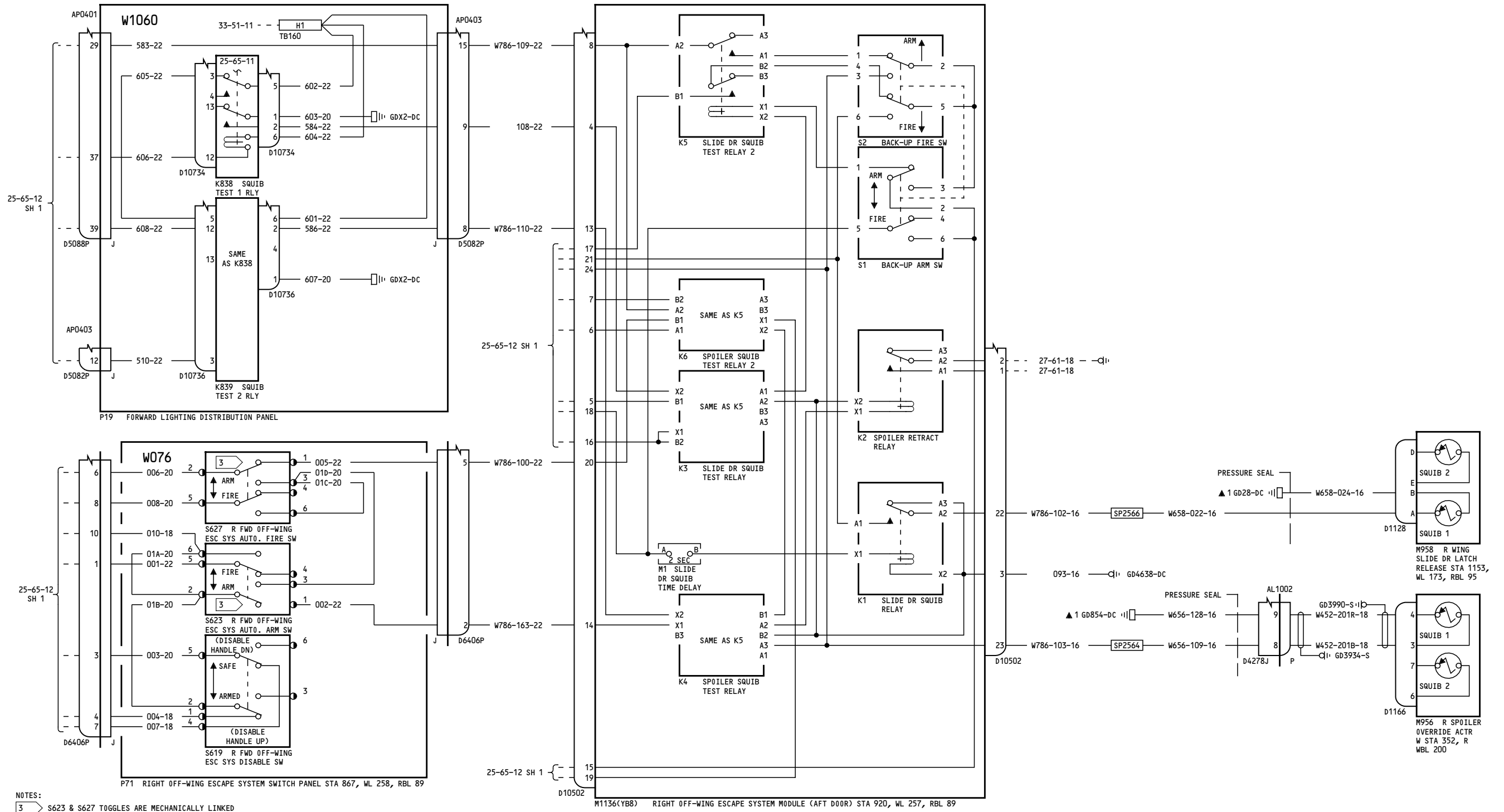

275-299

**RIGHT OFF-WING
ESCAPE SYSTEM**

25-65-12

Page 3
Sheet 2
Jan 21/2005

D280T132

25-65-12

Page 3
Sheet 2
Jan 21/2005