

**CHAPTER**

**27**

**FLIGHT CONTROLS**



767-200/300

WIRING DIAGRAM MANUAL

CHAPTER 27  
FLIGHT CONTROLS

CH-SC-SU	Schem	Page	Sheet	Date	CH-SC-SU	Schem	Page	Sheet	Date
27-EFFECTIVE PAGES		1 thru 3		Aug 05/2009	27-21-12 (cont.)		1		
		4		BLANK				2	Jan 21/2005
27-CONTENTS					27-21-22		1		Jan 21/2005
		1		Jun 28/2006	27-23-11		1		Jan 21/2005
		2		Mar 14/2007			2		Jan 21/2005
		3		Mar 14/2007	27-28-11		1		Jan 21/2005
		4		Mar 14/2007			2		Jan 21/2005
		5		Jun 06/2008			3		Jan 21/2005
		6		Jun 06/2008	27-28-13		1		Jan 21/2005
		7		Mar 14/2007			1		Jan 21/2005
		8		Feb 06/2009	27-31-11		1		Jan 21/2005
		9		Aug 15/2007			1		Jan 21/2005
		10		BLANK	27-32-11		1		Jan 21/2005
27-ALPHABETICAL INDEX									
		1		Jan 21/2005					
		2		Jan 21/2005			1		Jan 21/2005
27-09-11							1.1		May 20/2005
		1		Jan 21/2005			2		Jan 21/2005
27-09-12							2.1		May 20/2005
		1	1	Jan 21/2005			2.2		May 20/2005
			2	Jan 21/2005			3.1		Jan 21/2005
27-09-13							3.2A		Mar 14/2007
		1		Jan 21/2005			3.3		May 20/2005
		1.1		Jan 21/2005			4.1		May 20/2005
		2		Jan 21/2005			4.2A		Mar 14/2007
27-09-14					27-32-12		1		Jan 21/2005
		1	1	Jan 21/2005			2		Jan 21/2005
			2	Jan 21/2005					
27-11-11					27-32-21		1.1		Jan 21/2005
		1		Jan 21/2005			1.2		May 20/2005
		2		Jan 21/2005			2		Jan 21/2005
		3		Jan 21/2005			2.1		May 20/2005
27-11-12							3.1		Jan 21/2005
		1		Jan 21/2005			3.2		May 20/2005
		2		Jan 21/2005			3.3		May 20/2005
		3		Jan 21/2005			3.4		May 20/2005
		4		Jan 21/2005			4		Jan 21/2005
27-11-22							4.1		Mar 14/2007
		1		Jan 21/2005			5.1		Mar 14/2007
		2		Jan 21/2005			5.2A		Mar 14/2007
		3		Jan 21/2005			6.1		Mar 14/2007
27-13-11							6.2A		Mar 14/2007
		1		Jan 21/2005			7.1		Mar 14/2007
27-18-11							7.2A		Mar 14/2007
		1		Jan 21/2005					
		2		Jan 21/2005	27-32-22		1		Jan 21/2005
		3		Jan 21/2005			2		Jan 21/2005
27-21-11									
		1		Jan 21/2005	27-32-31		1		Jan 21/2005
27-21-12							2		Jan 21/2005
		1	1	Jan 21/2005					
							1		Jan 21/2005
							2		Jan 21/2005

A = Added, R = Revised, D = Deleted, O = Overflow

27-EFFECTIVE PAGES

Page 1  
Aug 05/2009

D280T132



767-200/300

WIRING DIAGRAM MANUAL

CHAPTER 27  
FLIGHT CONTROLS

CH-SC-SU	Schem	Page	Sheet	Date	CH-SC-SU	Schem	Page	Sheet	Date
27-38-11		1		Jan 21/2005	27-51-31		1		Jan 21/2005
		2		Jan 21/2005	27-51-41		1	1	Jan 21/2005
		3		Jan 21/2005				2	Jan 21/2005
		4		Jan 21/2005	27-51-51		1		Mar 14/2007
27-41-11		1	1	Jan 21/2005			2		Mar 14/2007
		2		Jan 21/2005			3		Mar 14/2007
	1.1	1		Jan 21/2005	27-51-61		1.1	1	Jan 21/2005
		2		Jan 21/2005				2	Jan 21/2005
	2	1		Jan 21/2005				3	Jan 21/2005
		2		Jan 21/2005			1.2	1	Jan 21/2005
	2.1	1		Jan 21/2005				2	Jan 21/2005
		2		Jan 21/2005				3	Jan 21/2005
	3	1		Jan 21/2005			2.1	1	Jan 21/2005
		2		Jan 21/2005				2	Jan 21/2005
	3.1	1		Jan 21/2005				3	Jan 21/2005
		2		Jan 21/2005			2.2	1	Jan 21/2005
	4	1		Jan 21/2005				2	Jun 06/2008
		2		Jan 21/2005				3	Jan 21/2005
	5	1		Jan 21/2005			3	1	Jan 21/2005
		2		Jan 21/2005				2	Jan 21/2005
	6	1		Jan 21/2005				3	Jan 21/2005
		2		Jan 21/2005			3.1	1	Jan 21/2005
27-41-21		1	1	Jan 21/2005				2	Jun 06/2008
		2		Jan 21/2005				3	Jan 21/2005
	1.1	1		Jan 21/2005				3	Jan 21/2005
		2		Jan 21/2005			4.1	1	Jan 21/2005
	2	1		Jan 21/2005				2	Jan 21/2005
		2		Jan 21/2005				3	Jan 21/2005
	2.1	1		Jan 21/2005			4.2	1	Jan 21/2005
		2		Jan 21/2005				2	Jan 21/2005
	3	1		Jan 21/2005				3	Jan 21/2005
		2		Jan 21/2005			5.1	1	Jan 21/2005
	3.1	1		Jan 21/2005				2	Jan 21/2005
		2		Jan 21/2005				3	Jan 21/2005
	4	1		Jan 21/2005			6	1	Jan 21/2005
		2		Jan 21/2005				2	Jan 21/2005
	5	1		Jan 21/2005				3	Jan 21/2005
		2		Jan 21/2005			6.1	1	Jan 21/2005
27-41-31								2	Jun 06/2008
								3	Jan 21/2005
27-48-11		1		Jan 21/2005	27-58-11		1		Jan 21/2005
							2		Jan 21/2005
27-51-11					27-58-21		1	1	Jan 21/2005
								2	Jan 21/2005
	1.1	1		Jan 21/2005			2	1	Jan 21/2005
		2		Jan 21/2005				2	Jan 21/2005
							3	1	Jan 21/2005

A = Added, R = Revised, D = Deleted, O = Overflow

27-EFFECTIVE PAGES

Page 2  
Aug 05/2009

D280T132



767-200/300

WIRING DIAGRAM MANUAL

CHAPTER 27  
FLIGHT CONTROLS

CH-SC-SU	Schem	Page	Sheet	Date	CH-SC-SU	Schem	Page	Sheet	Date
27-58-21 (cont.)		3			27-62-11 (cont.)		3.1		
			2	Jan 21/2005				3	Aug 15/2007
27-58-31					27-81-11				
	1			Jan 21/2005		1.1	1		Jan 21/2005
27-61-11								2	Jan 21/2005
	1			Jan 21/2005	27-81-21				
	2.1			Jan 21/2005		1.1	1		Jan 21/2005
	3			Jan 21/2005				2	Jan 21/2005
	4			Jan 21/2005		2	1		Jan 21/2005
	5.1			Jan 21/2005				2	Jan 21/2005
27-61-12						2.1	1		Jan 21/2005
	1		1	Jan 21/2005				2	Jan 21/2005
			2	Jan 21/2005		3.1	1		Jan 21/2005
27-61-13								2	Jan 21/2005
	1		1	Jan 21/2005	27-81-31				
			2	Jan 21/2005		1.1			Jan 21/2005
	2		1	Jan 21/2005		2.1			Jan 21/2005
			2	Jan 21/2005		3			Jan 21/2005
27-61-14						4			Jan 21/2005
	1		1	Jan 21/2005		5.1			Jan 21/2005
			2	Jan 21/2005	27-88-11				
	2		1	Jan 21/2005		1			Jan 21/2005
			2	Jan 21/2005		2			Jan 21/2005
27-61-15						2.1			Jan 21/2005
	1		1	Jan 21/2005		3.1			Jan 21/2005
			2	Jan 21/2005	27-88-12				
	2		1	Jan 21/2005		1	1		Jan 21/2005
			2	Jan 21/2005				2	Jan 21/2005
27-61-16					27-88-22				
	1		1	Jan 21/2005		1	1		Jan 21/2005
			2	Jan 21/2005				2	Jan 21/2005
	2		1	Jan 21/2005	27-89-11				
			2	Jan 21/2005		1			Jan 21/2005
27-61-17						2.1			Jan 21/2005
	1		1	Jan 21/2005		3.1			Jan 21/2005
			2	Jan 21/2005		4.1			Jan 21/2005
	2		1	Jan 21/2005		5.1			Jan 21/2005
			2	Jan 21/2005					
27-61-18									
	1		1	Jan 21/2005					
			2	Jan 21/2005					
	2		1	Jan 21/2005					
			2	Jan 21/2005					
27-62-11									
	1.1		1	Feb 06/2009					
			2	Aug 15/2007					
			3	Aug 15/2007					
	2.1		1	Feb 06/2009					
			2	Aug 15/2007					
			3	Mar 09/2006					
	3.1		1	Feb 06/2009					
			2	Aug 15/2007					

A = Added, R = Revised, D = Deleted, O = Overflow

27-EFFECTIVE PAGES

Page 3  
Aug 05/2009

D280T132



767-200/300

WIRING DIAGRAM MANUAL

CHAPTER 27  
FLIGHT CONTROLS

Title	CH-SC-SU	Schem	Page	Sheet	Date	Effectivity
<b><u>FLIGHT CONTROL SYSTEM ELECTRONIC UNITS</u></b>						
CSEU RACKS- POWER INPUT	27-09-11		1		Jan 21/2005	ALL
CSEU RACKS- AIR/GROUND INPUT	27-09-12		1	1	Jan 21/2005	ALL
				2	Jan 21/2005	ALL
CSEU RACKS- HYDRAULIC INPUT	27-09-13		1		Jan 21/2005	050-099 150-199 275-276 280-299
			1.1		Jan 21/2005	050-276
			2		Jan 21/2005	277-278
CSEU RACKS- MAINTENANCE ANNUNCIATION	27-09-14		1	1	Jan 21/2005	ALL
				2	Jan 21/2005	ALL
<b><u>AILERON AND AILERON TRIM CONTROL SYSTEM</u></b>						
AILERON TRIM CONTROL	27-11-11		1		Jan 21/2005	050-099
			2		Jan 21/2005	150-154 275
			3		Jan 21/2005	155-199 276-299
OUTBOARD AILERON LOCKOUT- LEFT	27-11-12		1		Jan 21/2005	050-099
			2		Jan 21/2005	150-199
			3		Jan 21/2005	275-276
			4		Jan 21/2005	277-299
OUTBOARD AILERON LOCKOUT- RIGHT	27-11-22		1		Jan 21/2005	050-099
			2		Jan 21/2005	150-199 275-276
			3		Jan 21/2005	277-299
<b><u>AILERON AND SPOILER HYDRAULIC SHUTOFF VALVES</u></b>						
AILERON & SPOILER HYDRAULIC SHUTOFF VALVES	27-13-11		1		Jan 21/2005	ALL
<b><u>AILERON POSITION INDICATING SYSTEM</u></b>						
AILERON POSITION INDICATION	27-18-11		1		Jan 21/2005	050-099
			2		Jan 21/2005	150-154 162-165 275-276
			3		Jan 21/2005	155-157 166-199 277-299

**27-CONTENTS**



767-200/300

WIRING DIAGRAM MANUAL

CHAPTER 27  
FLIGHT CONTROLS

Title	CH-SC-SU	Schem	Page	Sheet	Date	Effectivity
<b><u>RUDDER AND RUDDER TRIM CONTROL SYSTEM</u></b>						
RUDDER TRIM CONTROL	27-21-11		1		Jan 21/2005	ALL
RUDDER RATIO CHANGER-LEFT	27-21-12		1	1	Jan 21/2005	ALL
				2	Jan 21/2005	ALL
RUDDER RATIO CHANGER-RIGHT	27-21-22		1		Jan 21/2005	ALL
<b><u>RUDDER AND ELEVATOR SHUTOFF VALVES</u></b>						
TAIL HYDRAULIC SHUTOFF VALVES	27-23-11		1		Jan 21/2005	050-099
			2		Jan 21/2005	150-199 275-299
<b><u>RUDDER POSITION INDICATING SYSTEM</u></b>						
RUDDER POSITION INDICATION	27-28-11		1		Jan 21/2005	050-099
			2		Jan 21/2005	150-154 162-165 275-276
			3		Jan 21/2005	155-157 166-199 277-299
RUDDER TRIM POSITION INDICATION	27-28-13		1		Jan 21/2005	ALL
<b><u>ELEVATOR CONTROL SYSTEM</u></b>						
ELEVATOR FEEL WARNING INDICATION	27-31-11		1		Jan 21/2005	ALL
<b><u>STALL WARNING SYSTEM</u></b>						
WEU STALL WARNING- LEFT	27-32-11		1		Jan 21/2005	050-099
			1.1		May 20/2005	050-051
			2		Jan 21/2005	151
			2.1		May 20/2005	150 152-167
			2.2		May 20/2005	150-167
			3.1		Jan 21/2005	275-276
			3.2A		Mar 14/2007	275-278
			3.3		May 20/2005	277-278
			4.1		May 20/2005	280
			4.2A		Mar 14/2007	280
WEU STALL WARNING BITE & STATUS- LEFT	27-32-12		1		Jan 21/2005	050-099
			2		Jan 21/2005	150-199 275-299

**27-CONTENTS**



767-200/300

WIRING DIAGRAM MANUAL

CHAPTER 27  
FLIGHT CONTROLS

Title	CH-SC-SU	Schem	Page	Sheet	Date	Effectivity
WEU STALL WARNING- RIGHT	27-32-21		1.1		Jan 21/2005	050
			1.2		May 20/2005	050
			2		Jan 21/2005	051-099
			2.1		May 20/2005	051
			3.1		Jan 21/2005	150 152-154
			3.2		May 20/2005	150 152-157
			3.3		May 20/2005	155-167
			3.4		May 20/2005	162-167
			4		Jan 21/2005	151
			4.1		Mar 14/2007	151
			5.1		Mar 14/2007	275-276
			5.2A		Mar 14/2007	275-276
			6.1		Mar 14/2007	277-278
			6.2A		Mar 14/2007	277-278
			7.1		Mar 14/2007	280
	7.2A		Mar 14/2007	280		
WEU STALL WARNING BITE & STATUS- RIGHT	27-32-22		1		Jan 21/2005	050-099
			2		Jan 21/2005	150-199 275-299
STICK NUDGER	27-32-31		1		Jan 21/2005	050-099 150-199 275-278
			2		Jan 21/2005	280-299
<b><u>ELEVATOR POSITION INDICATING SYSTEM</u></b>						
ELEVATOR POSITION INDICATION	27-38-11		1		Jan 21/2005	050-099
			2		Jan 21/2005	150-154 162-165 275-276
			3		Jan 21/2005	155 157 167-199 277-299
			4		Jan 21/2005	156 166
<b><u>HORIZONTAL STABILIZER TRIM CONTROL SYSTEM</u></b>						
MANUAL STABILIZER TRIM- LEFT	27-41-11		1	1	Jan 21/2005	050-099
				2	Jan 21/2005	050-099
			1.1	1	Jan 21/2005	050-051
				2	Jan 21/2005	050-051
			2	1	Jan 21/2005	150-154

**27-CONTENTS**

Page 3  
Mar 14/2007

D280T132



767-200/300

**WIRING DIAGRAM MANUAL**

**CHAPTER 27  
FLIGHT CONTROLS**

Title	CH-SC-SU	Schem	Page	Sheet	Date	Effectivity		
MANUAL STABILIZER TRIM- LEFT (cont.)	27-41-11			2	Jan 21/2005	150-154		
			2.1	1	Jan 21/2005	150-154		
				2	Jan 21/2005	150-154		
			3	1	Jan 21/2005	155-166		
				2	Jan 21/2005	155-166		
			3.1	1	Jan 21/2005	155-166		
				2	Jan 21/2005	155-166		
			4	1	Jan 21/2005	167-199		
				2	Jan 21/2005	167-199		
			5	1	Jan 21/2005	275-277		
				2	Jan 21/2005	275-277		
			6	1	Jan 21/2005	278-299		
				2	Jan 21/2005	278-299		
		MANUAL STABILIZER TRIM- RIGHT	27-41-21		1	1	Jan 21/2005	050-099
						2	Jan 21/2005	050-099
					1.1	1	Jan 21/2005	050-051
				2	Jan 21/2005	050-051		
	2			1	Jan 21/2005	150-154		
				2	Jan 21/2005	150-154		
	2.1			1	Jan 21/2005	150-154		
				2	Jan 21/2005	150-154		
	3			1	Jan 21/2005	155-166 275-277		
				2	Jan 21/2005	155-166 275-277		
	3.1			1	Jan 21/2005	155-166		
				2	Jan 21/2005	155-166		
	4			1	Jan 21/2005	167-199		
				2	Jan 21/2005	167-199		
	5			1	Jan 21/2005	278-299		
				2	Jan 21/2005	278-299		
MANUAL STABILIZER TRIM- ALTERNATE CONTROL	27-41-31		1		Jan 21/2005	050-099 155-199 275-299		

**27-CONTENTS**





767-200/300

WIRING DIAGRAM MANUAL

CHAPTER 27  
FLIGHT CONTROLS

Title	CH-SC-SU	Schem	Page	Sheet	Date	Effectivity	
<b><u>STABILIZER TRIM POSITION INDICATING SYSTEM</u></b>							
STABILIZER TRIM POSITION INDICATOR	27-48-11		1		Jan 21/2005	050-099 162-164	
			2		Jan 21/2005	150-154 275-276	
			3		Jan 21/2005	155-156 165-166	
			4		Jan 21/2005	157 167-199	
			5		Jan 21/2005	277-299	
<b><u>TRAILING EDGE FLAP SYSTEM</u></b>							
ALTERNATE TRAILING EDGE FLAP DRIVE	27-51-11		1.1	1	Jan 21/2005	050-280	
				2	Jan 21/2005	050-280	
TRAILING EDGE FLAP SHUTOFF VALVE	27-51-31		1		Jan 21/2005	ALL	
TRAILING EDGE FLAP ASYMMETRY INDICATION	27-51-41		1	1	Jan 21/2005	ALL	
				2	Jan 21/2005	ALL	
TRAILING EDGE FLAP LOAD RELIEF	27-51-51		1		Mar 14/2007	050-099	
			2		Mar 14/2007	150-157 275-299	
			3		Mar 14/2007	162-199	
FLAPS SLATS ELECTRONIC UNIT OUTPUT INTERFACE	27-51-61		1.1	1	Jan 21/2005	050-051	
				2	Jan 21/2005	050-051	
				3	Jan 21/2005	050-051	
			1.2	1	Jan 21/2005	050-051	
				2	Jan 21/2005	050-051	
				3	Jan 21/2005	050-051	
			2.1	1	Jan 21/2005	150-166	
				2	Jan 21/2005	150-166	
				3	Jan 21/2005	150-166	
			2.2	1	Jan 21/2005	150-166	
				2	Jun 06/2008	150-166	
				3	Jan 21/2005	150-166	
				3	1	Jan 21/2005	167-199 280-299
					2	Jan 21/2005	167-199 280-299

**27-CONTENTS**



767-200/300

WIRING DIAGRAM MANUAL

CHAPTER 27  
FLIGHT CONTROLS

Title	CH-SC-SU	Schem	Page	Sheet	Date	Effectivity
FLAPS SLATS ELECTRONIC UNIT OUTPUT INTERFACE (cont.)	27-51-61			3	Jan 21/2005	167-199 280-299
			3.1	1	Jan 21/2005	167 280
				2	Jun 06/2008	167 280
				3	Jan 21/2005	167 280
			4.1	1	Jan 21/2005	275-276
				2	Jan 21/2005	275-276
				3	Jan 21/2005	275-276
			4.2	1	Jan 21/2005	275-276
				2	Jan 21/2005	275-276
				3	Jan 21/2005	275-276
			5.1	1	Jan 21/2005	277
				2	Jan 21/2005	277
				3	Jan 21/2005	277
			6	1	Jan 21/2005	278
				2	Jan 21/2005	278
				3	Jan 21/2005	278
			6.1	1	Jan 21/2005	278
				2	Jun 06/2008	278
				3	Jan 21/2005	278
<b><u>TE FLAP POSITION INDICATING SYSTEM</u></b>						
TRAILING EDGE FLAP POSITION INDICATION	27-58-11		1		Jan 21/2005	050-099 150-155 162-165 275-276
			2		Jan 21/2005	156-157 166-199 277-299
FLAP STABILIZER POSITION SENSING	27-58-21		1	1	Jan 21/2005	050 155-199
				2	Jan 21/2005	050 155-199
			2	1	Jan 21/2005	051-099 150-154
				2	Jan 21/2005	051-099 150-154
			3	1	Jan 21/2005	275-299
				2	Jan 21/2005	275-299
FLAP MASTER INDICATION	27-58-31		1		Jan 21/2005	ALL

**27-CONTENTS**



767-200/300

WIRING DIAGRAM MANUAL

CHAPTER 27  
FLIGHT CONTROLS

Title	CH-SC-SU	Schem	Page	Sheet	Date	Effectivity
<b>SPOILER/SPEEDBRAKE CONTROL SYSTEM</b>						
SPOILER CONTROL- FLAPS INPUT	27-61-11		1		Jan 21/2005	050-099 155-156 162-166
			2.1		Jan 21/2005	150-152
			3		Jan 21/2005	153-154
			4		Jan 21/2005	157 167-199 277-299
			5.1		Jan 21/2005	275-276
SPOILER CONTROL- FAULT ANNUNCIATION	27-61-12		1	1	Jan 21/2005	ALL
				2	Jan 21/2005	ALL
SPOILER CONTROL- SURFACE PANELS 1 & 12	27-61-13		1	1	Jan 21/2005	050-099 150-199
				2	Jan 21/2005	050-099 150-199
			2	1	Jan 21/2005	275-299
				2	Jan 21/2005	275-299
SPOILER CONTROL- SURFACE PANELS 2 & 11	27-61-14		1	1	Jan 21/2005	050-099 150-199
				2	Jan 21/2005	050-099 150-199
			2	1	Jan 21/2005	275-299
				2	Jan 21/2005	275-299
SPOILER CONTROL- SURFACE PANELS 3 & 10	27-61-15		1	1	Jan 21/2005	050-099 150-199
				2	Jan 21/2005	050-099 150-199
			2	1	Jan 21/2005	275-299
				2	Jan 21/2005	275-299
SPOILER CONTROL- SURFACE PANELS 4 & 9	27-61-16		1	1	Jan 21/2005	050-099 150-199
				2	Jan 21/2005	050-099 150-199
			2	1	Jan 21/2005	275-299
				2	Jan 21/2005	275-299
SPOILER CONTROL- SURFACE PANELS 5 & 8	27-61-17		1	1	Jan 21/2005	050-099 150-157
				2	Jan 21/2005	050-099 150-157
			2	1	Jan 21/2005	162-199 275-299
				2	Jan 21/2005	162-199 275-299

**27-CONTENTS**



767-200/300

WIRING DIAGRAM MANUAL

CHAPTER 27  
FLIGHT CONTROLS

Title	CH-SC-SU	Schem	Page	Sheet	Date	Effectivity
SPOILER CONTROL-SURFACE PANELS 6 & 7	27-61-18		1	1	Jan 21/2005	050-099
				2	Jan 21/2005	050-099
			2	1	Jan 21/2005	150-199 275-299
				2	Jan 21/2005	150-199 275-299
<b><u>AUTO-SPEEDBRAKE CONTROL SYSTEM</u></b>						
AUTOMATIC SPEED BRAKE SYSTEM	27-62-11		1.1	1	Feb 06/2009	050
				2	Aug 15/2007	050
				3	Aug 15/2007	050
			2.1	1	Feb 06/2009	051 151
				2	Aug 15/2007	051 151
				3	Mar 09/2006	051 151
			3.1	1	Feb 06/2009	150 152-280
				2	Aug 15/2007	150 152-280
				3	Aug 15/2007	150 152-280
<b><u>LEADING EDGE SLAT SYSTEM</u></b>						
ALTERNATE LEADING EDGE INBOARD SLAT DRIVE	27-81-11		1.1	1	Jan 21/2005	050-280
				2	Jan 21/2005	050-280
ALTERNATE LEADING EDGE OUTBOARD SLAT DRIVE	27-81-21		1.1	1	Jan 21/2005	050-051
				2	Jan 21/2005	050-051
			2	1	Jan 21/2005	151
				2	Jan 21/2005	151
			2.1	1	Jan 21/2005	150-278
				2	Jan 21/2005	150-278
			3.1	1	Jan 21/2005	280
				2	Jan 21/2005	280
LEADING EDGE SLATS SHUTOFF VALVE	27-81-31		1.1		Jan 21/2005	050-051
				2.1	Jan 21/2005	150-156 162-166 275-276
				3	Jan 21/2005	157
				4	Jan 21/2005	167-199 278-299
				5.1	Jan 21/2005	277

**27-CONTENTS**



767-200/300

**WIRING DIAGRAM MANUAL**

**CHAPTER 27  
FLIGHT CONTROLS**

Title	CH-SC-SU	Schem	Page	Sheet	Date	Effectivity
<b><u>LEADING EDGE SLAT POSITION INDICATING SYSTEM</u></b>						
LEADING EDGE SLAT POSITION INDICATION- LEFT WING	27-88-11		1		Jan 21/2005	050-099
			2		Jan 21/2005	151
			2.1		Jan 21/2005	150-278
			3.1		Jan 21/2005	280
LEADING EDGE SLAT POSITION SWITCHES- LEFT WING	27-88-12		1	1	Jan 21/2005	ALL
				2	Jan 21/2005	ALL
LEADING EDGE SLAT POSITION SWITCHES- RIGHT WING	27-88-22		1	1	Jan 21/2005	ALL
				2	Jan 21/2005	ALL
<b><u>SLAT SKEW/LOSS DETECTION</u></b>						
LEADING EDGE SLAT SKEW DETECTION	27-89-11		1		Jan 21/2005	050-099
			2.1		Jan 21/2005	150 152-157 275-278
			3.1		Jan 21/2005	151
			4.1		Jan 21/2005	162-167
			5.1		Jan 21/2005	280

**27-CONTENTS**

Page 9

Aug 15/2007

D280T132



767-200/300

## WIRING DIAGRAM MANUAL

### CHAPTER 27 FLIGHT CONTROLS

CH-SC-SU	Title
27-13-11	AILERON & SPOILER HYDRAULIC SHUTOFF VALVES
27-18-11	AILERON POSITION INDICATION
27-11-11	AILERON TRIM CONTROL
27-81-11	ALTERNATE LEADING EDGE INBOARD SLAT DRIVE
27-81-21	ALTERNATE LEADING EDGE OUTBOARD SLAT DRIVE
27-51-11	ALTERNATE TRAILING EDGE FLAP DRIVE
27-62-11	AUTOMATIC SPEED BRAKE SYSTEM
27-09-12	CSEU RACKS- AIR/GROUND INPUT
27-09-13	CSEU RACKS- HYDRAULIC INPUT
27-09-14	CSEU RACKS- MAINTENANCE ANNUNCIATION
27-09-11	CSEU RACKS- POWER INPUT
27-31-11	ELEVATOR FEEL WARNING INDICATION
27-38-11	ELEVATOR POSITION INDICATION
27-58-31	FLAP MASTER INDICATION
27-58-21	FLAP STABILIZER POSITION SENSING
27-51-61	FLAPS SLATS ELECTRONIC UNIT OUTPUT INTERFACE
27-88-11	LEADING EDGE SLAT POSITION INDICATION- LEFT WING
27-88-12	LEADING EDGE SLAT POSITION SWITCHES- LEFT WING
27-88-22	LEADING EDGE SLAT POSITION SWITCHES- RIGHT WING
27-89-11	LEADING EDGE SLAT SKEW DETECTION
27-81-31	LEADING EDGE SLATS SHUTOFF VALVE
27-41-31	MANUAL STABILIZER TRIM- ALTERNATE CONTROL
27-41-11	MANUAL STABILIZER TRIM- LEFT
27-41-21	MANUAL STABILIZER TRIM- RIGHT
27-11-12	OUTBOARD AILERON LOCKOUT- LEFT
27-11-22	OUTBOARD AILERON LOCKOUT- RIGHT
27-28-11	RUDDER POSITION INDICATION
27-21-12	RUDDER RATIO CHANGER- LEFT

## 27-ALPHABETICAL INDEX

D280T132

Page 1  
Jan 21/2005



767-200/300

## WIRING DIAGRAM MANUAL

### CHAPTER 27 FLIGHT CONTROLS

CH-SC-SU	Title
27-21-22	RUDDER RATIO CHANGER- RIGHT
27-21-11	RUDDER TRIM CONTROL
27-28-13	RUDDER TRIM POSITION INDICATION
27-61-12	SPOILER CONTROL- FAULT ANNUNCIATION
27-61-11	SPOILER CONTROL- FLAPS INPUT
27-61-13	SPOILER CONTROL- SURFACE PANELS 1 & 12
27-61-14	SPOILER CONTROL- SURFACE PANELS 2 & 11
27-61-15	SPOILER CONTROL- SURFACE PANELS 3 & 10
27-61-16	SPOILER CONTROL- SURFACE PANELS 4 & 9
27-61-17	SPOILER CONTROL- SURFACE PANELS 5 & 8
27-61-18	SPOILER CONTROL- SURFACE PANELS 6 & 7
27-48-11	STABILIZER TRIM POSITION INDICATOR
27-32-31	STICK NUDGER
27-23-11	TAIL HYDRAULIC SHUTOFF VALVES
27-51-41	TRAILING EDGE FLAP ASYMMETRY INDICATION
27-51-51	TRAILING EDGE FLAP LOAD RELIEF
27-58-11	TRAILING EDGE FLAP POSITION INDICATION
27-51-31	TRAILING EDGE FLAP SHUTOFF VALVE
27-32-12	WEU STALL WARNING BITE & STATUS- LEFT
27-32-22	WEU STALL WARNING BITE & STATUS- RIGHT
27-32-11	WEU STALL WARNING- LEFT
27-32-21	WEU STALL WARNING- RIGHT

## 27-ALPHABETICAL INDEX

D280T132

Page 2  
Jan 21/2005

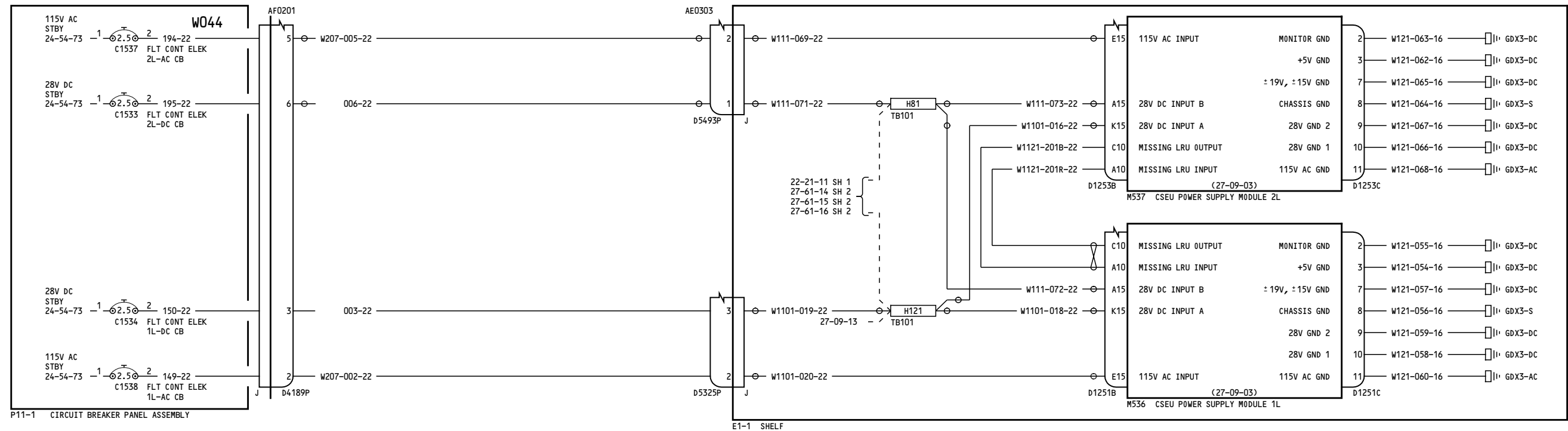
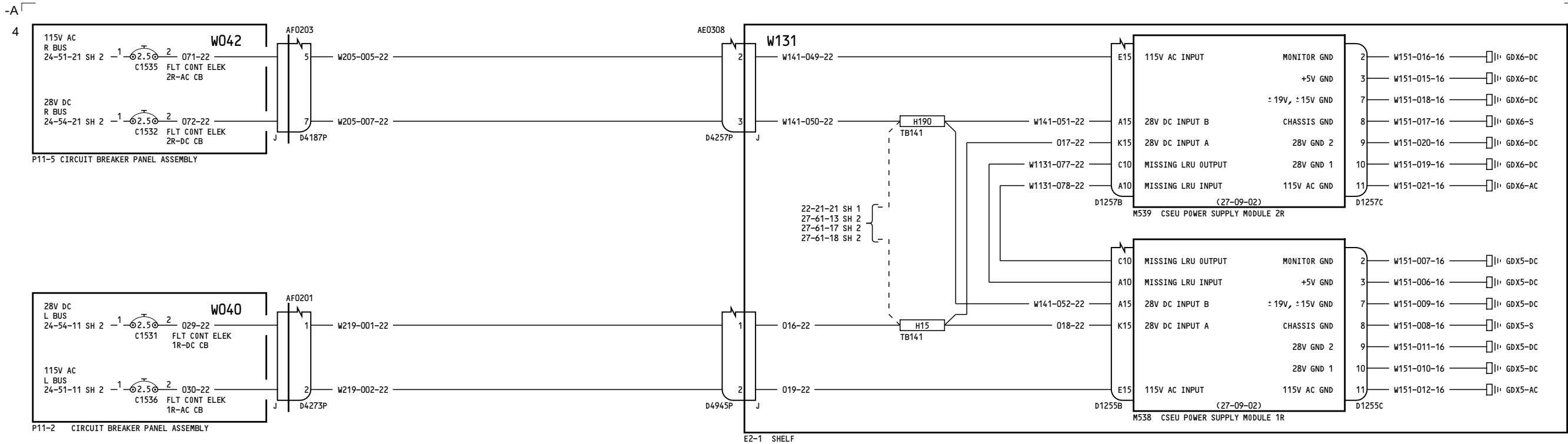

ALL	<b>CSEU RACKS- POWER INPUT</b>
	D280T132

**27-09-11**

Page 1

Jan 21/2005

**27-09-11**

Page 1

Jan 21/2005



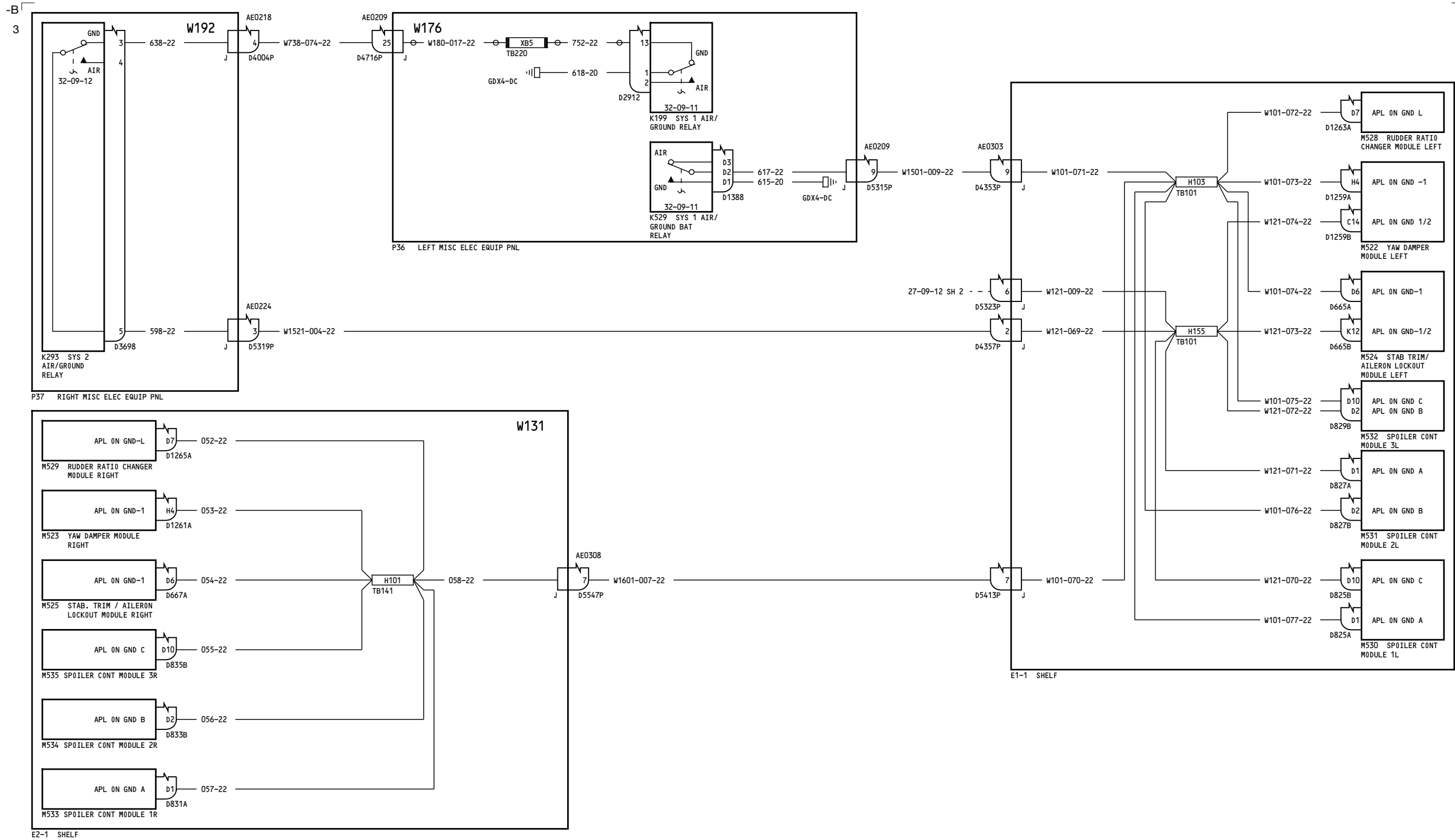

ALL

**CSEU RACKS-  
AIR/GROUND INPUT**

D280T132

**27-09-12**

Page 1  
Sheet 1  
Jan 21/2005

**27-09-12**

Page 1  
Sheet 1  
Jan 21/2005

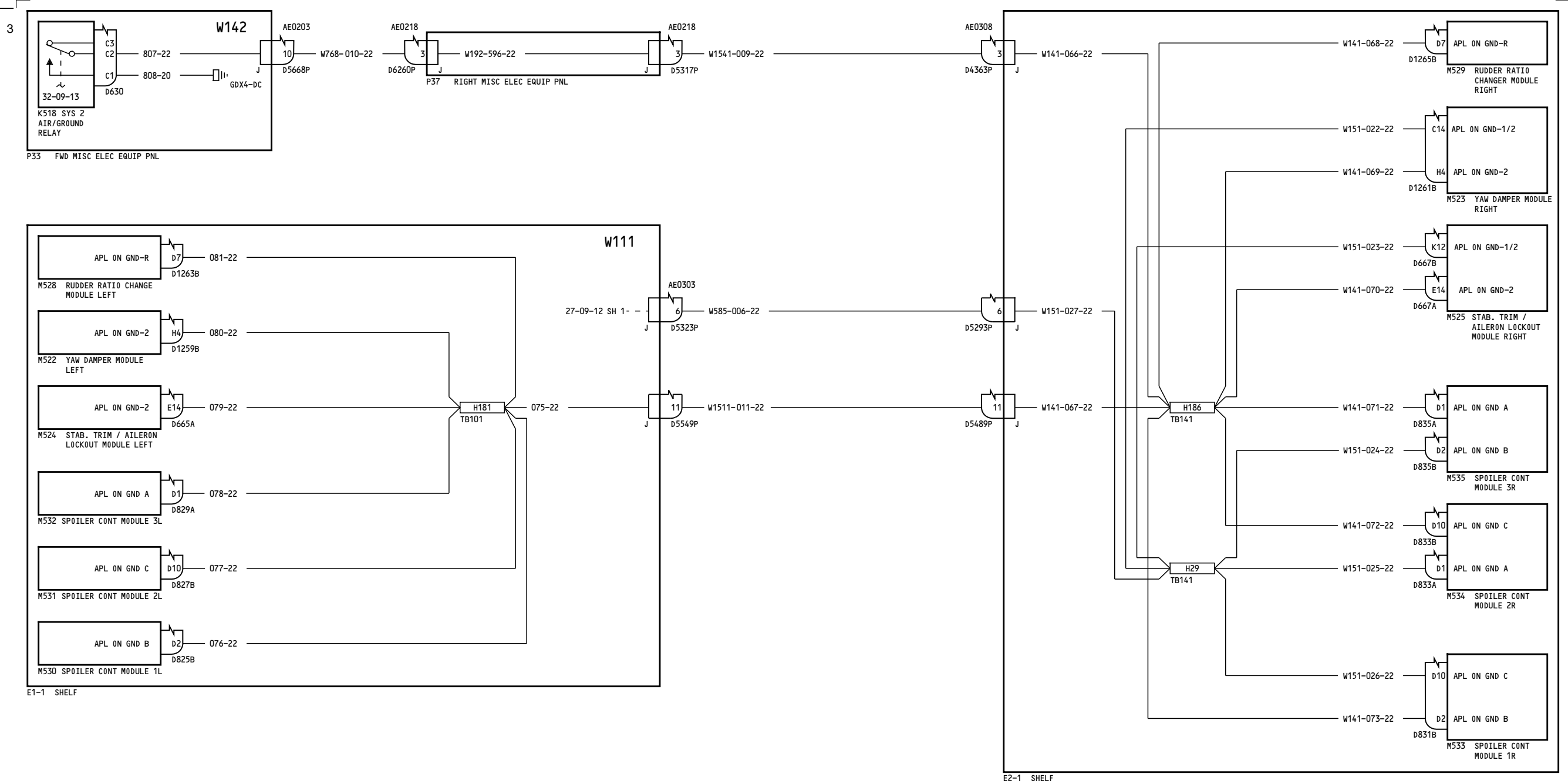

ALL

**CSEU RACKS-  
AIR/GROUND INPUT**

D280T132

**27-09-12**

Page 1  
 Sheet 2  
 Jan 21/2005

**27-09-12**

Page 1  
 Sheet 2  
 Jan 21/2005

5

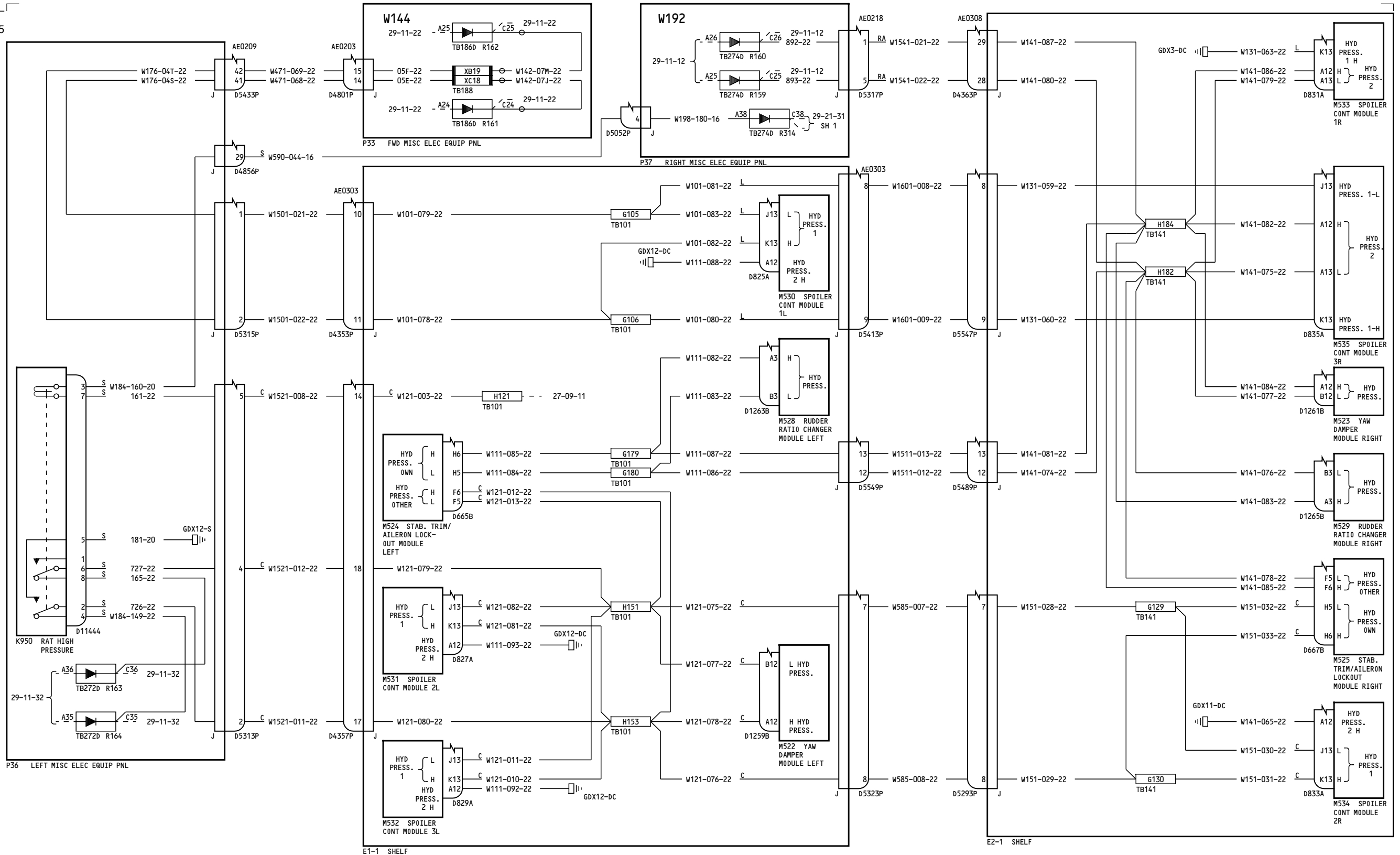

050-099, 150-199, 275-276, 280-299

CSEU RACKS-  
HYDRAULIC INPUT

27-09-13

Page 1

D280T132

Jan 21/2005

27-09-13

Page 1

Jan 21/2005

17

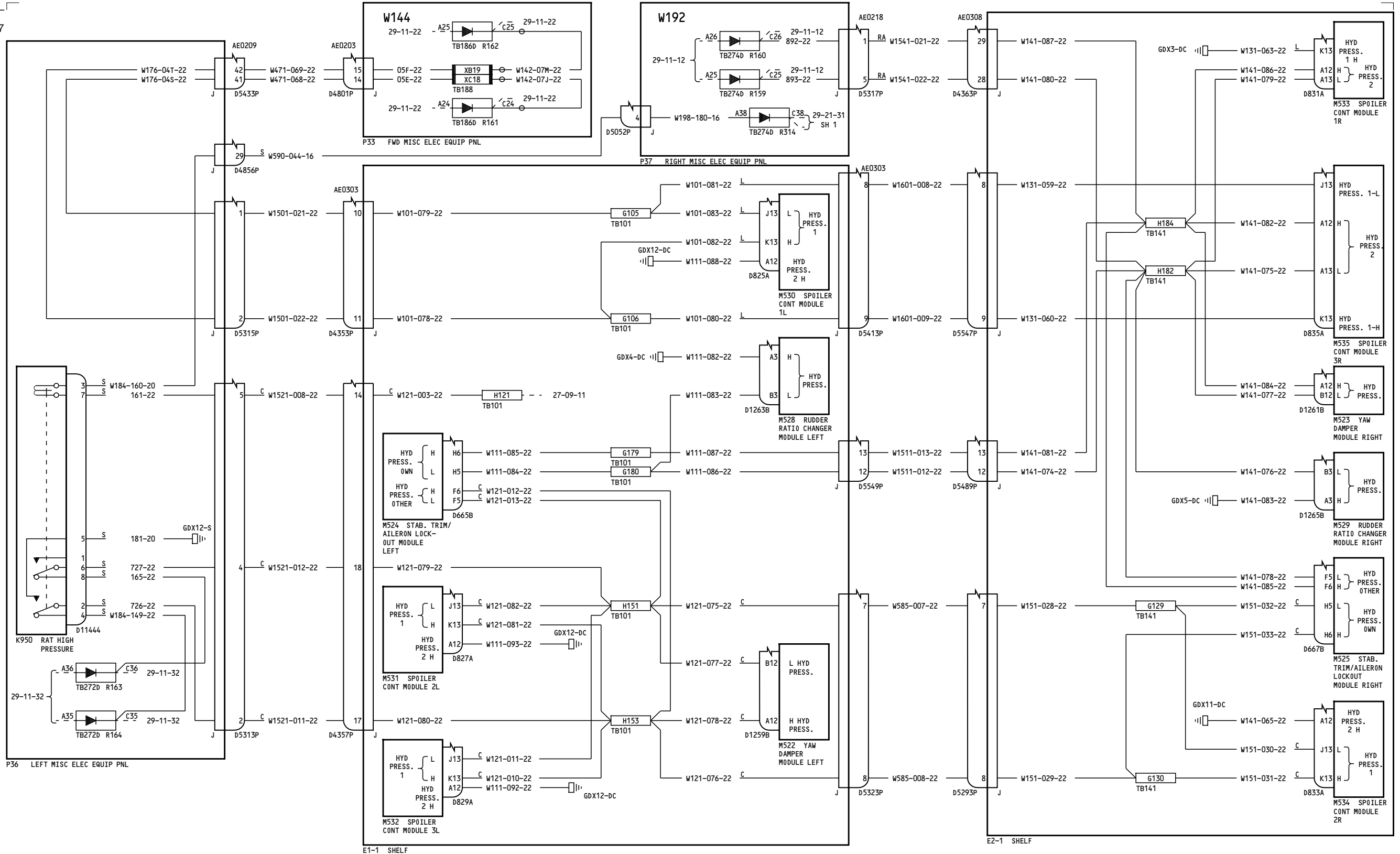

050-276

**CSEU RACKS-  
HYDRAULIC INPUT**

D280T132

27-09-13

Page 1.1

Jan 21/2005

Incorporates  
27-0145

27-09-13

Page 1.1

Jan 21/2005

17

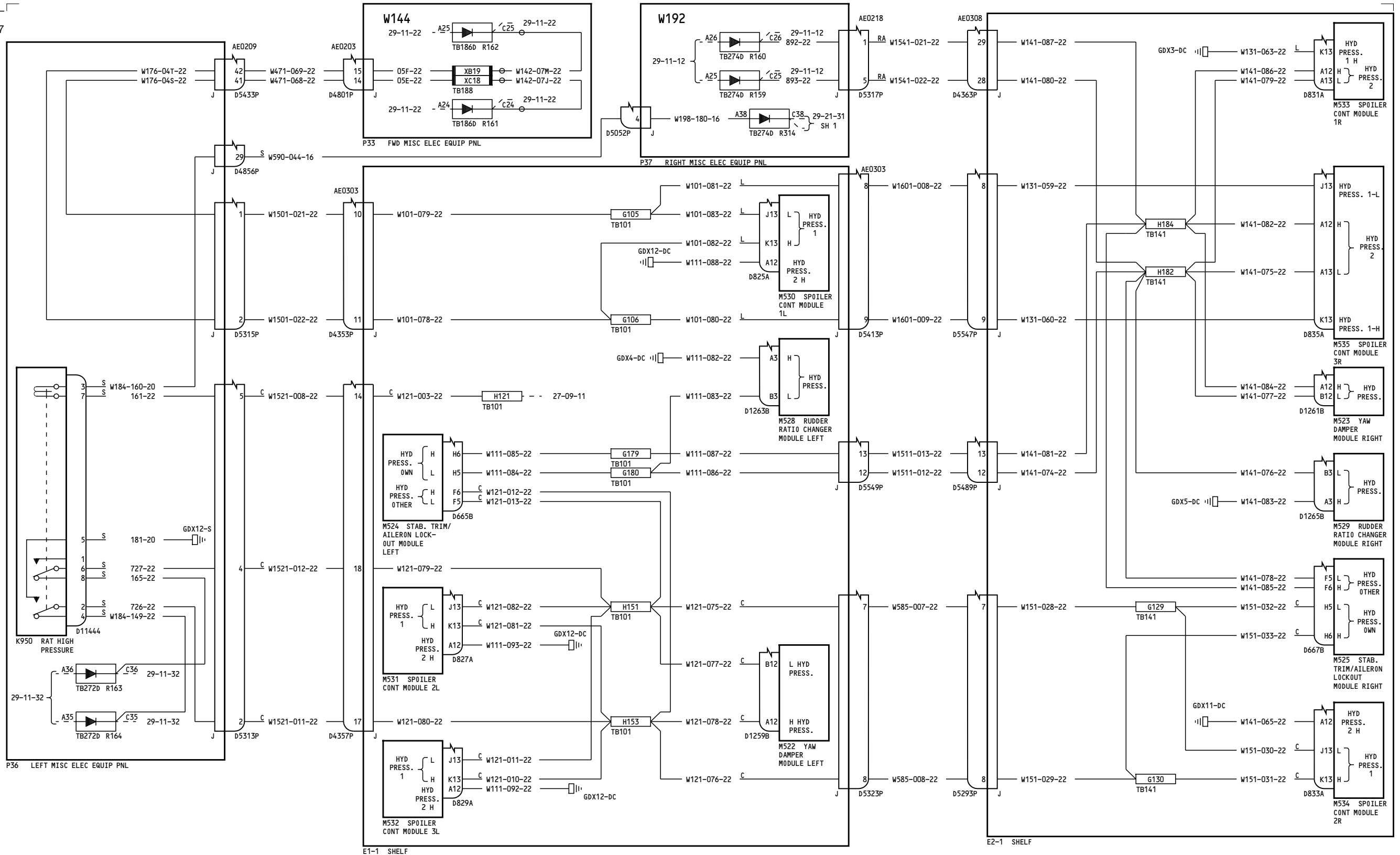

277-278

## CSEU RACKS-HYDRAULIC INPUT

**27-09-13**

Page 2

D280T132

Jan 21/2005

**27-09-13**

Page 2

Jan 21/2005

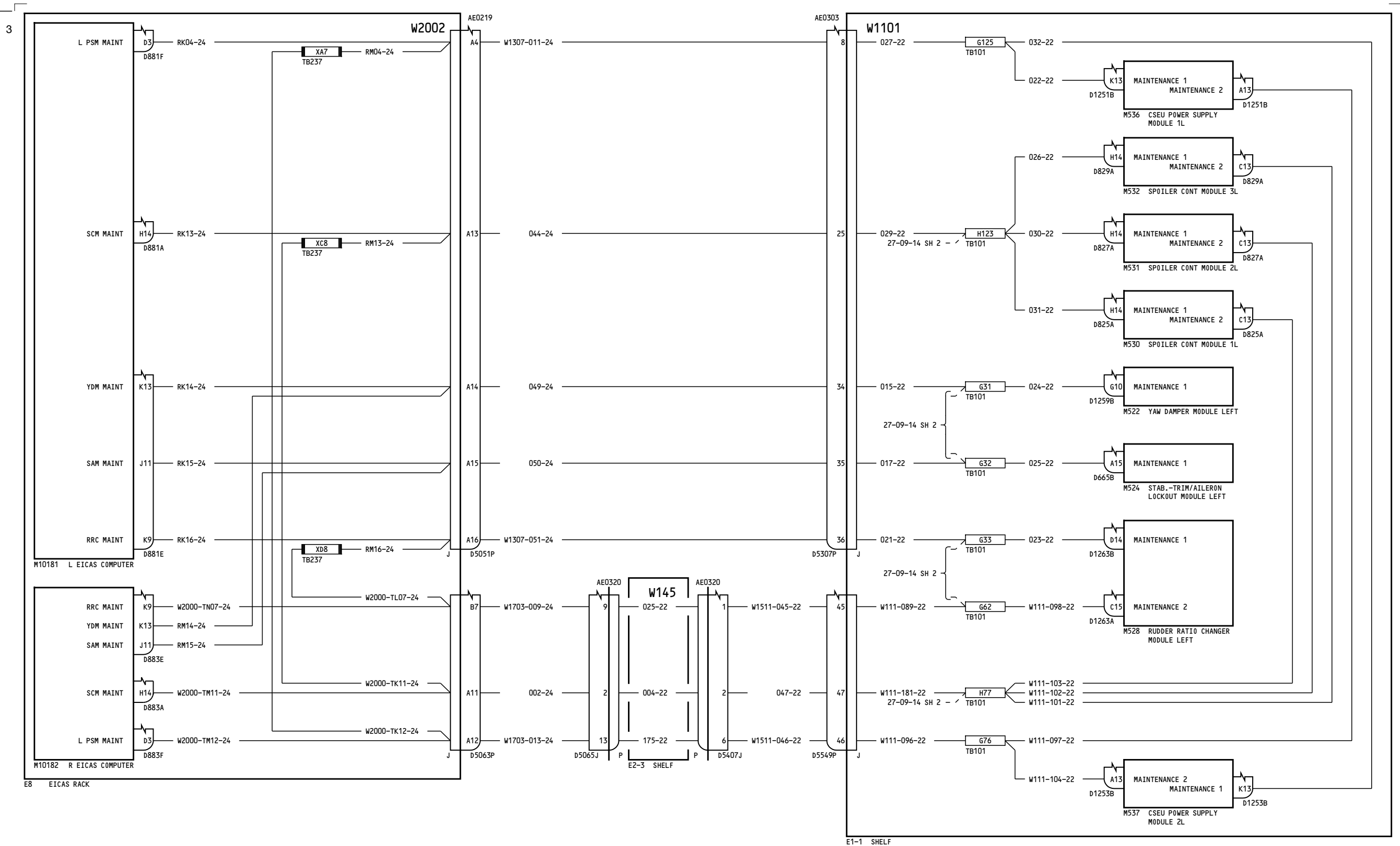

ALL

**CSEU RACKS-  
MAINTENANCE ANNUNCIATION**

**27-09-14**

Page 1  
Sheet 1  
Jan 21/2005

D280T132

**27-09-14**

Page 1  
Sheet 1  
Jan 21/2005

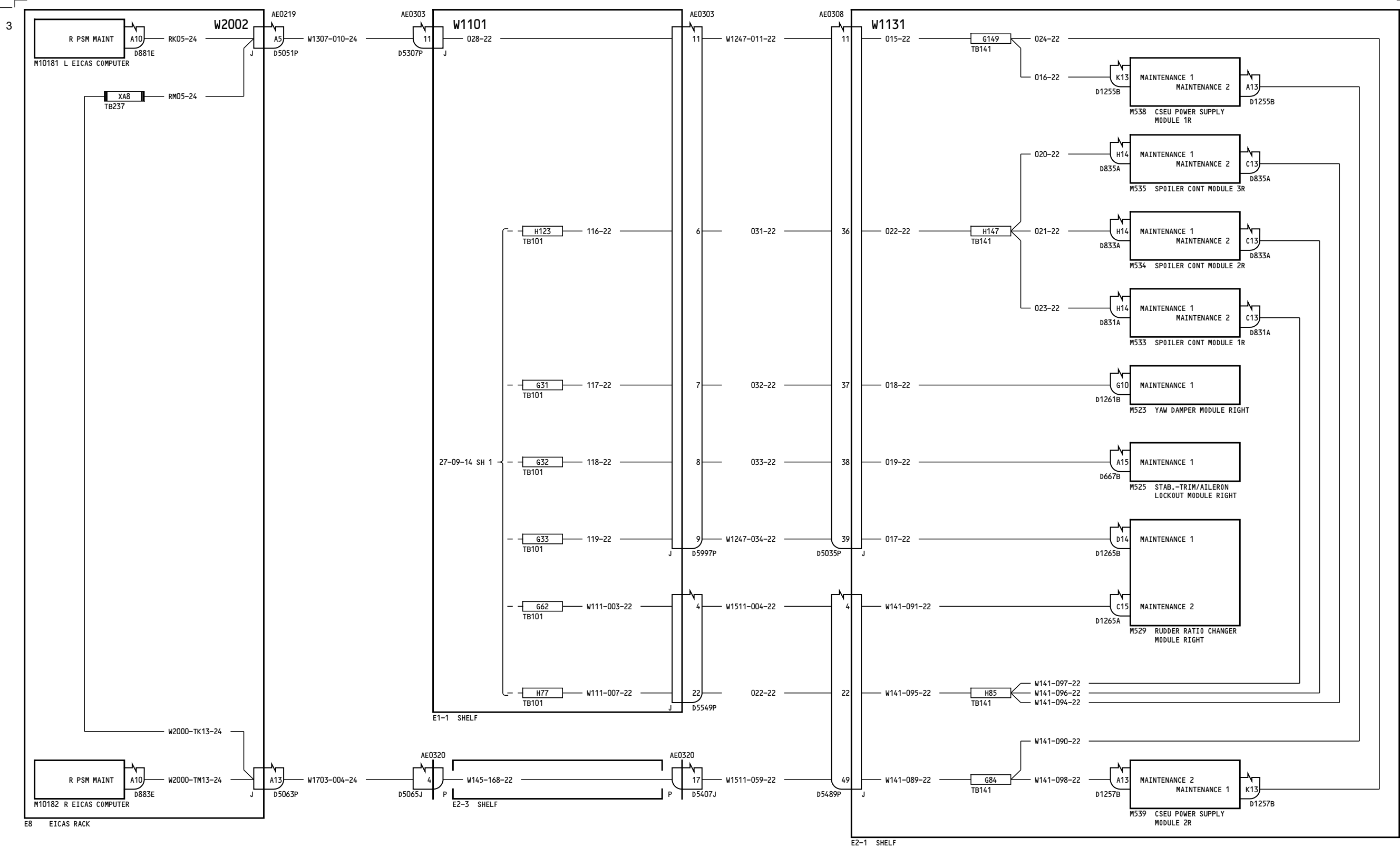

ALL

**CSEU RACKS-  
MAINTENANCE ANNUNCIATION**

**27-09-14**

Page 1  
Sheet 2  
Jan 21/2005

D280T132

**27-09-14**

Page 1  
Sheet 2  
Jan 21/2005

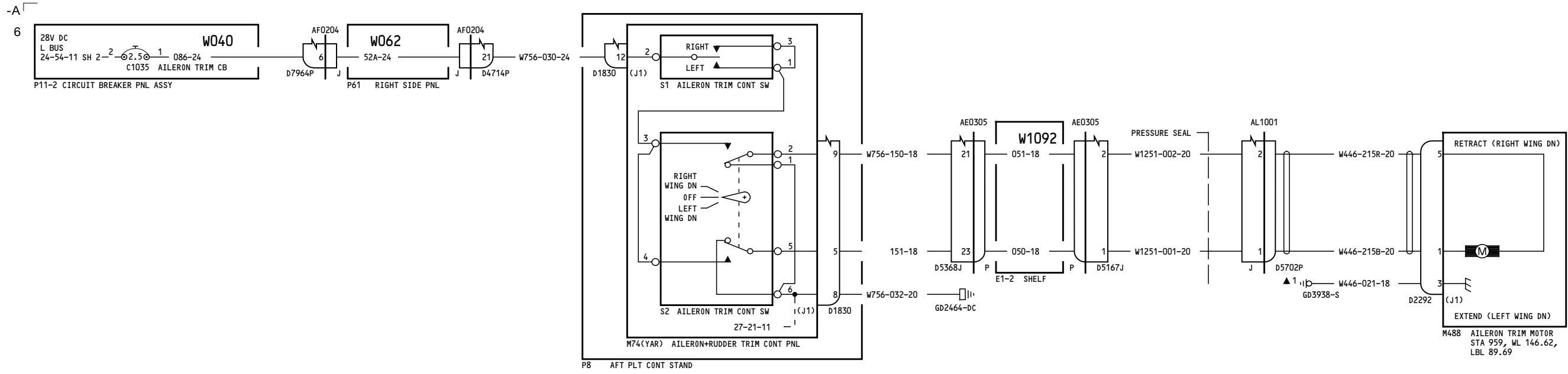

050-099

AILERON TRIM CONTROL

27-11-11

Page 1

D280T132

Jan 21/2005

27-11-11

Page 1

Jan 21/2005



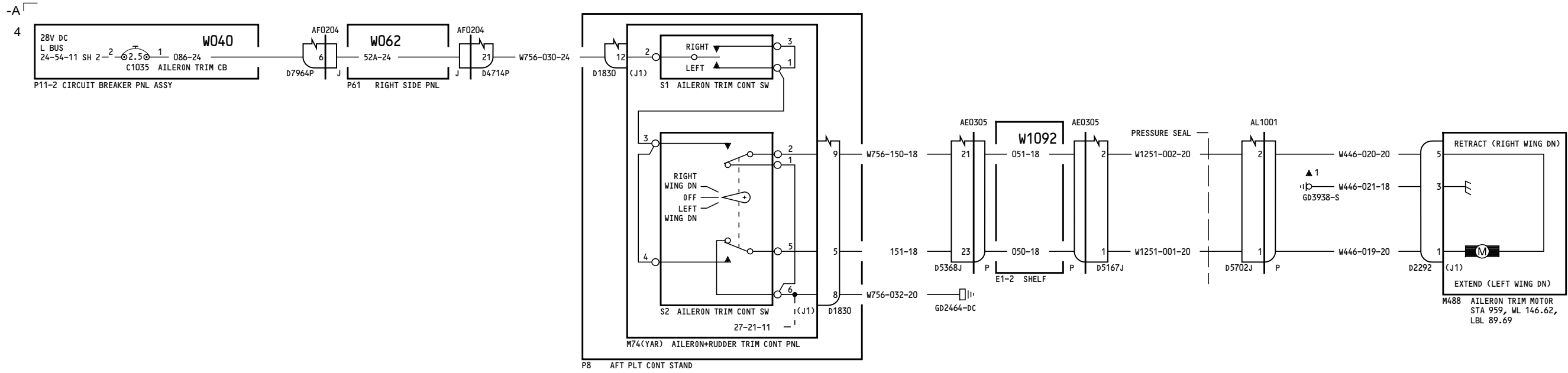

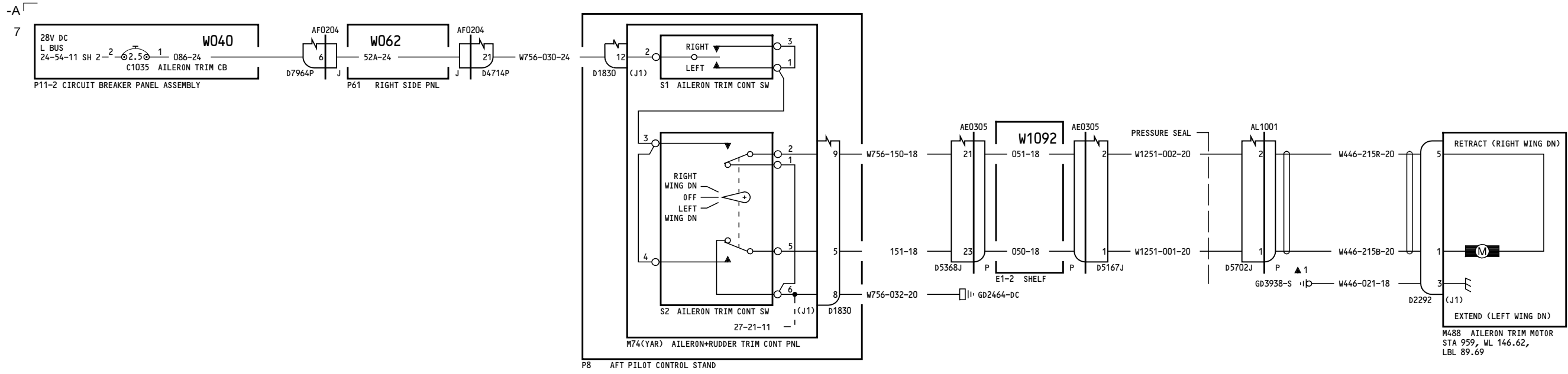

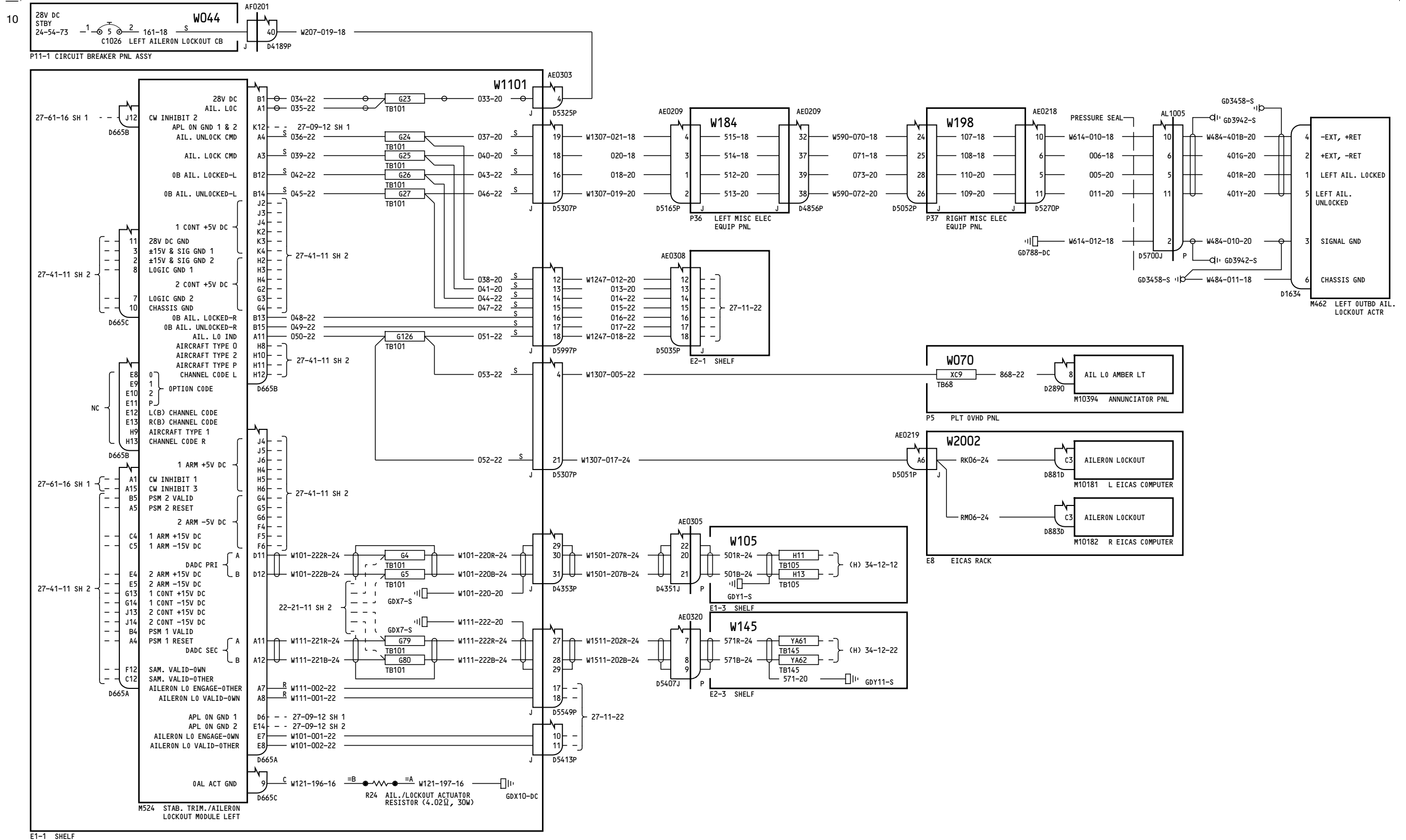

050-099

**OUTBOARD AILERON LOCKOUT-LEFT**

**27-11-12**

Page 1

D280T132

Jan 21/2005

27-11-12

Page 1

Jan 21/2005

27-11-12

Page 1

Jan 21/2005

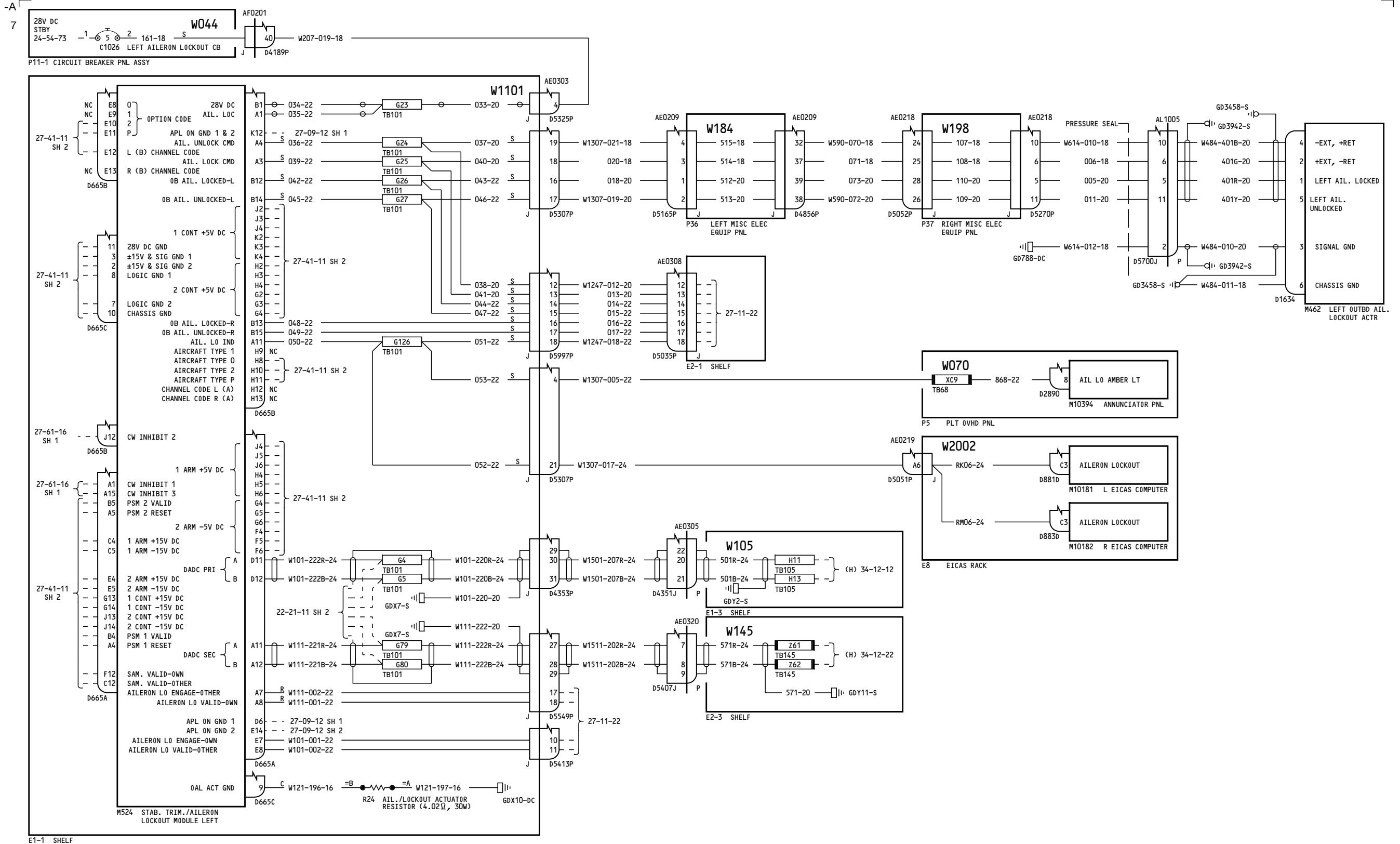

150-199

**OUTBOARD AILERON LOCKOUT-LEFT**

27-11-12

Page 2

D280T132

Jan 21/2005

27-11-12

Page 2

Jan 21/2005

27-11-12

Page 2

Jan 21/2005

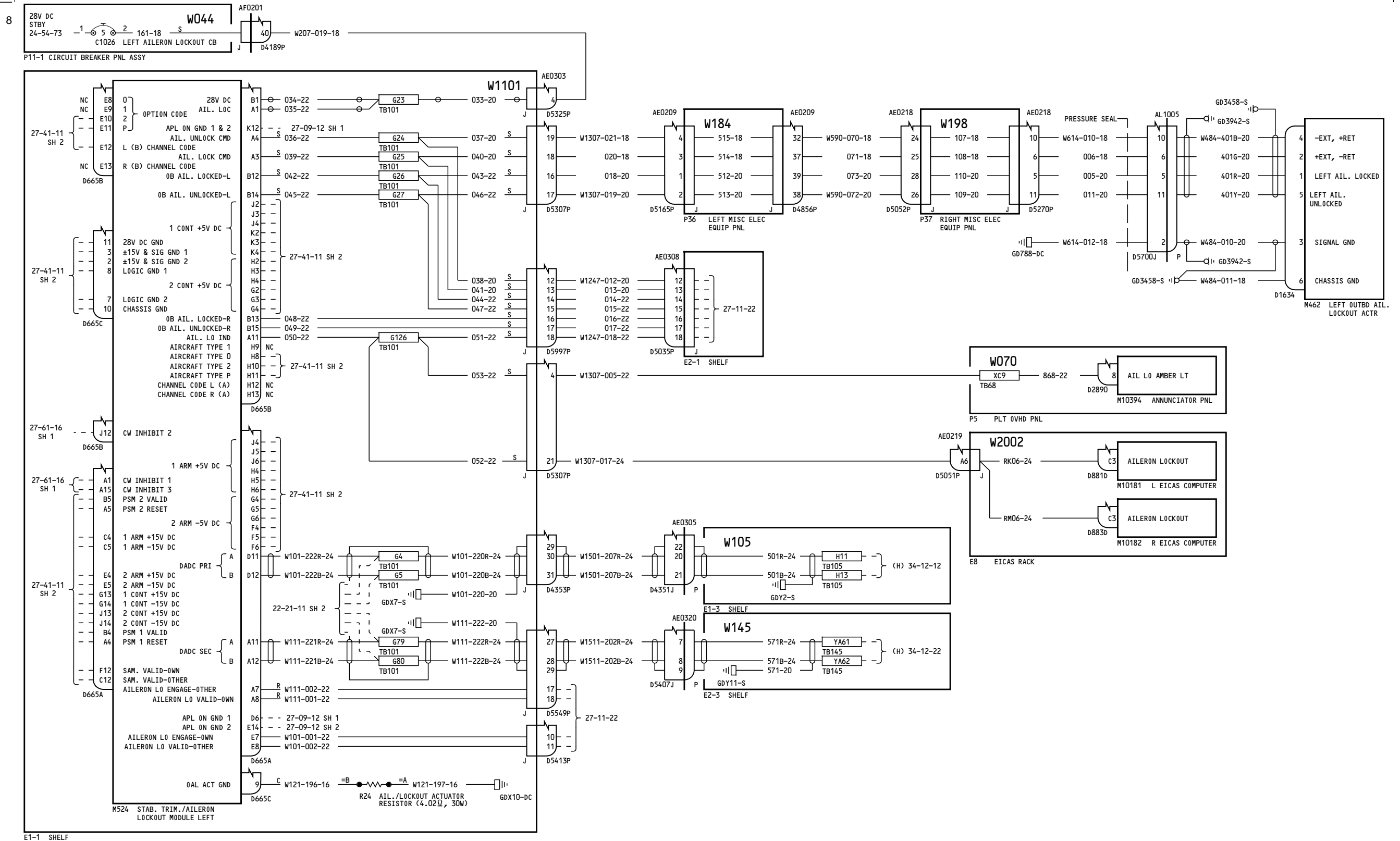

275-276

**OUTBOARD AILERON LOCKOUT-LEFT**

27-11-12

Page 3

D280T132

Jan 21/2005

**27-11-12**

Page 3

Jan 21/2005

12

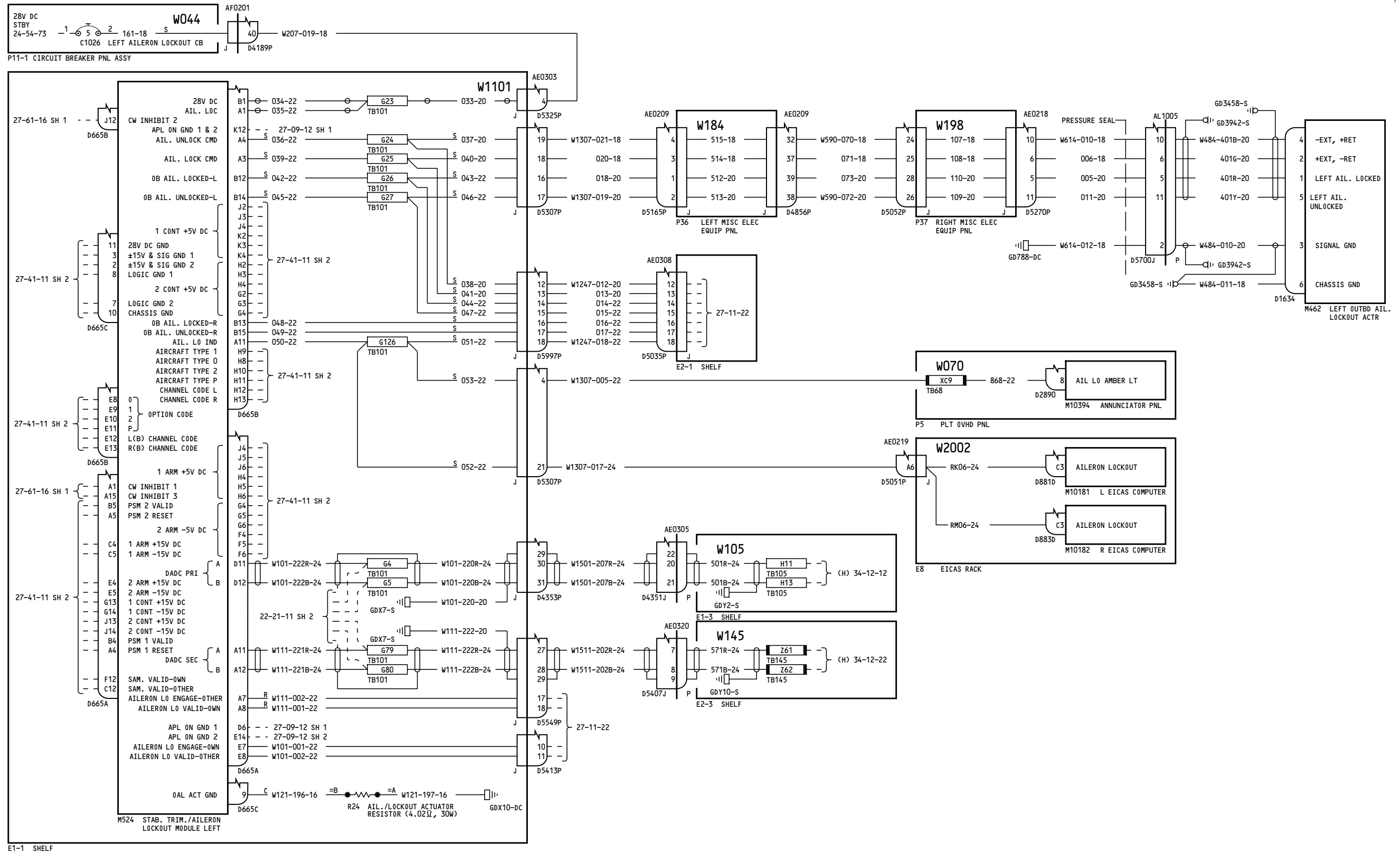

E1-1 SHELF

277-299

**OUTBOARD AILERON LOCKOUT-LEFT**

**27-11-12**

Page 4

D280T132

**27-11-12**

Page 4

Jan 21/2005

**27-11-12**

Page 4

Jan 21/2005

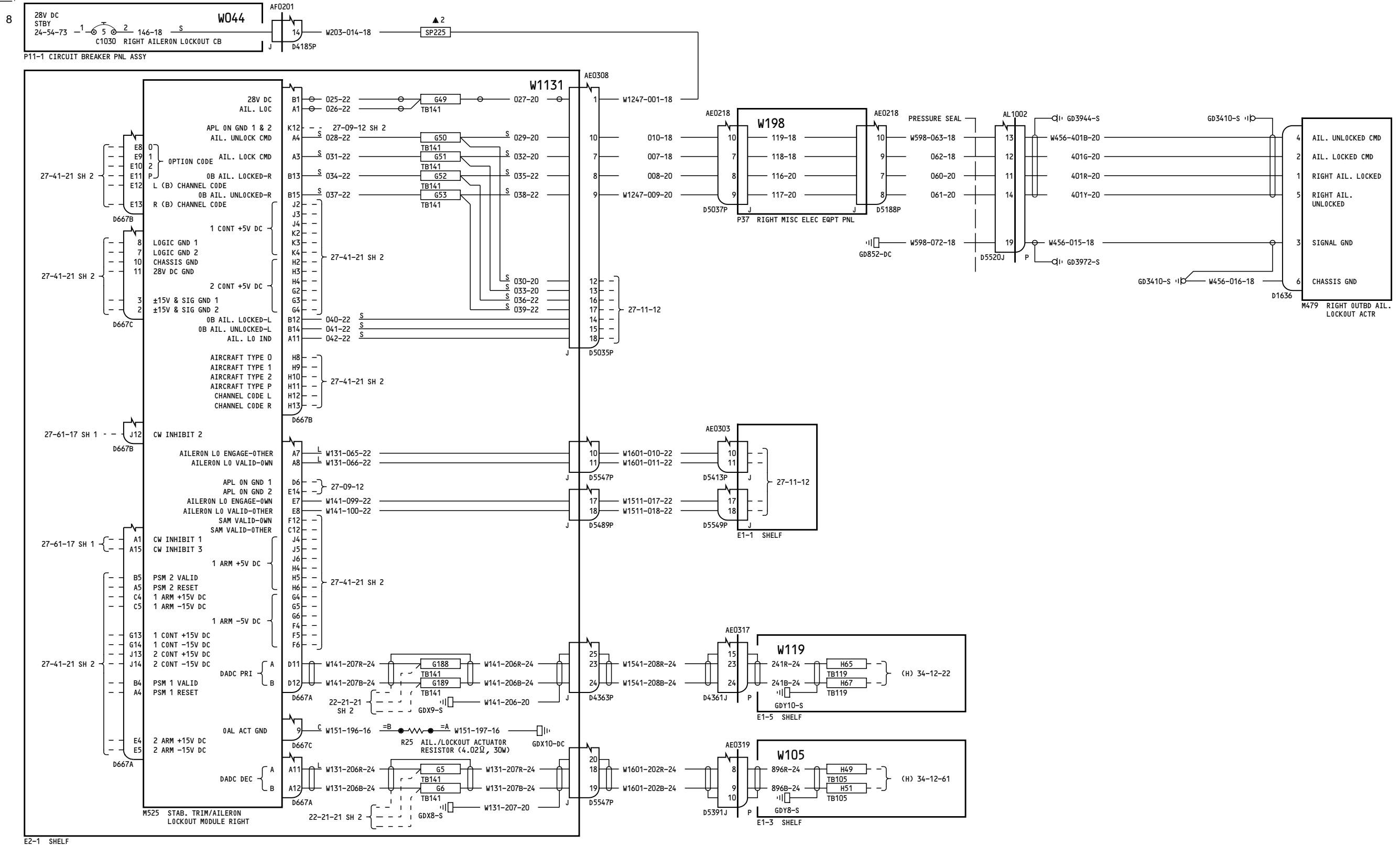

050-099

**OUTBOARD AILERON LOCKOUT-RIGHT**

D280T132

**27-11-22**

Page 1

Jan 21/2005

**27-11-22**

Page 1

Jan 21/2005

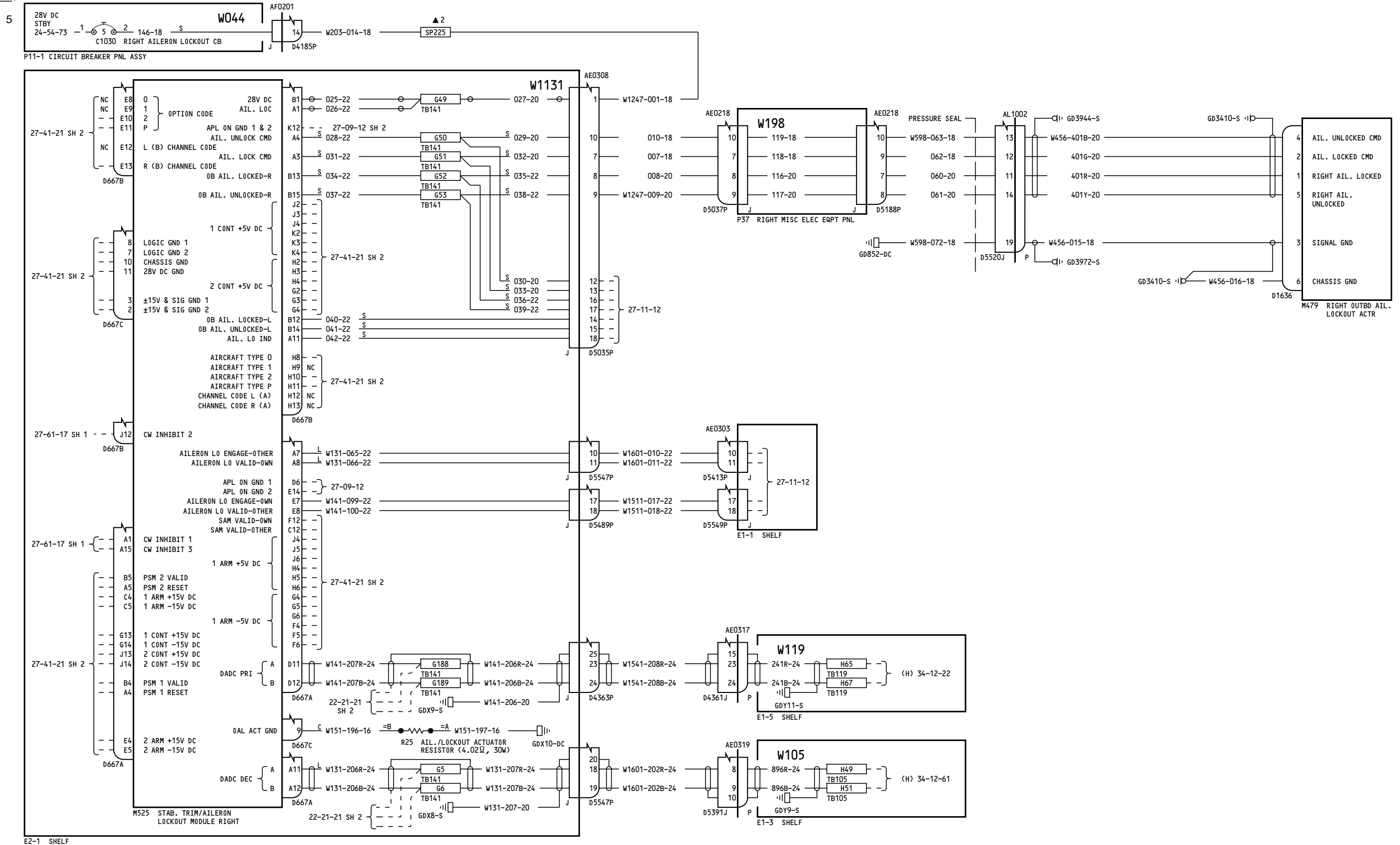

150-199, 275-276

**OUTBOARD AILERON LOCKOUT-RIGHT**

**27-11-22**

Page 2

Jan 21/2005

D280T132

**27-11-22**

Page 2

Jan 21/2005

**27-11-22**

Page 2

Jan 21/2005



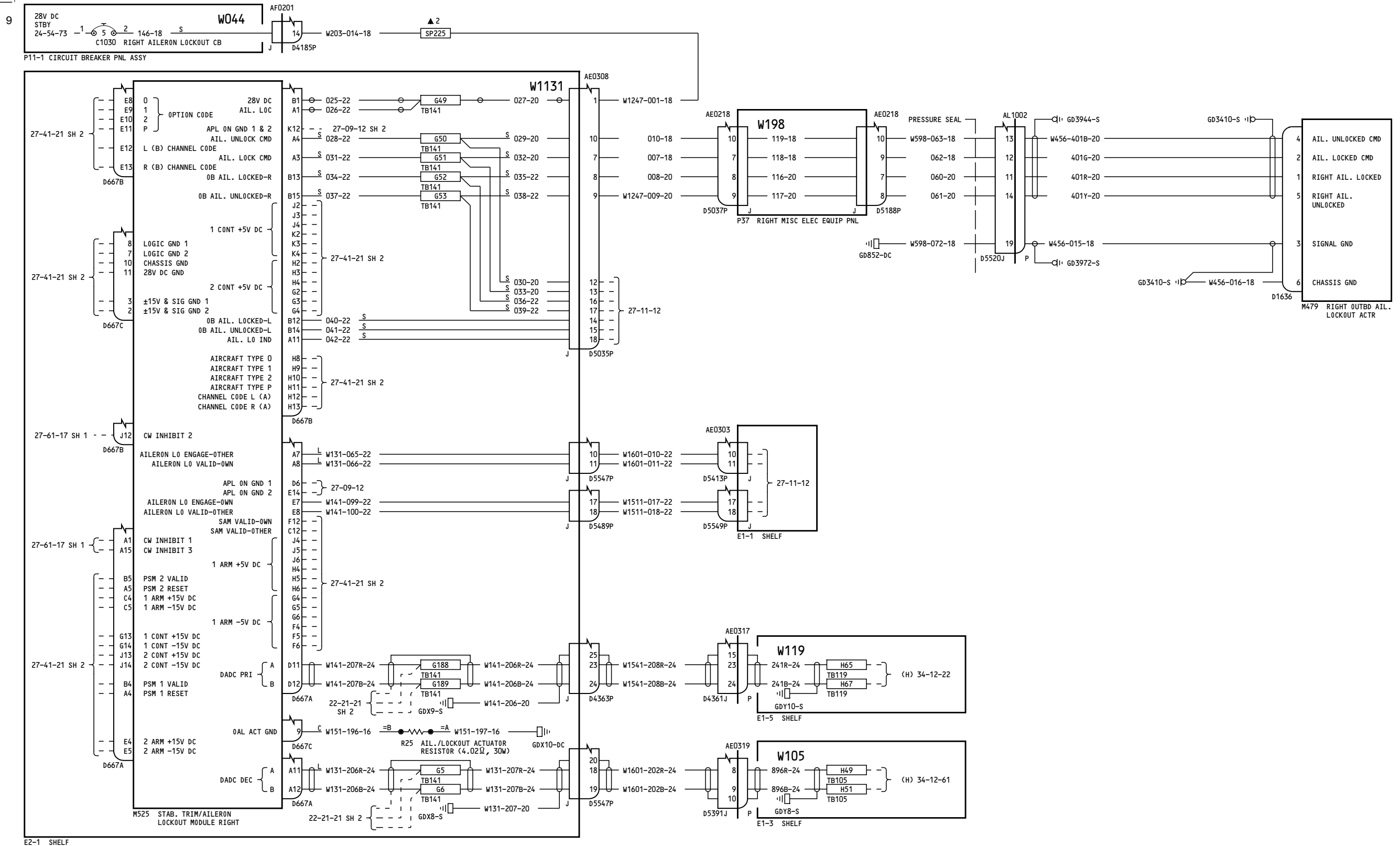

277-299

**OUTBOARD AILERON LOCKOUT-RIGHT**

**27-11-22**

Page 3

Jan 21/2005

D280T132

**27-11-22**

Page 3

Jan 21/2005

BOEING PROPRIETARY - Copyright © - Unpublished Work - See title page for details.

**27-11-22**

Page 3

Jan 21/2005

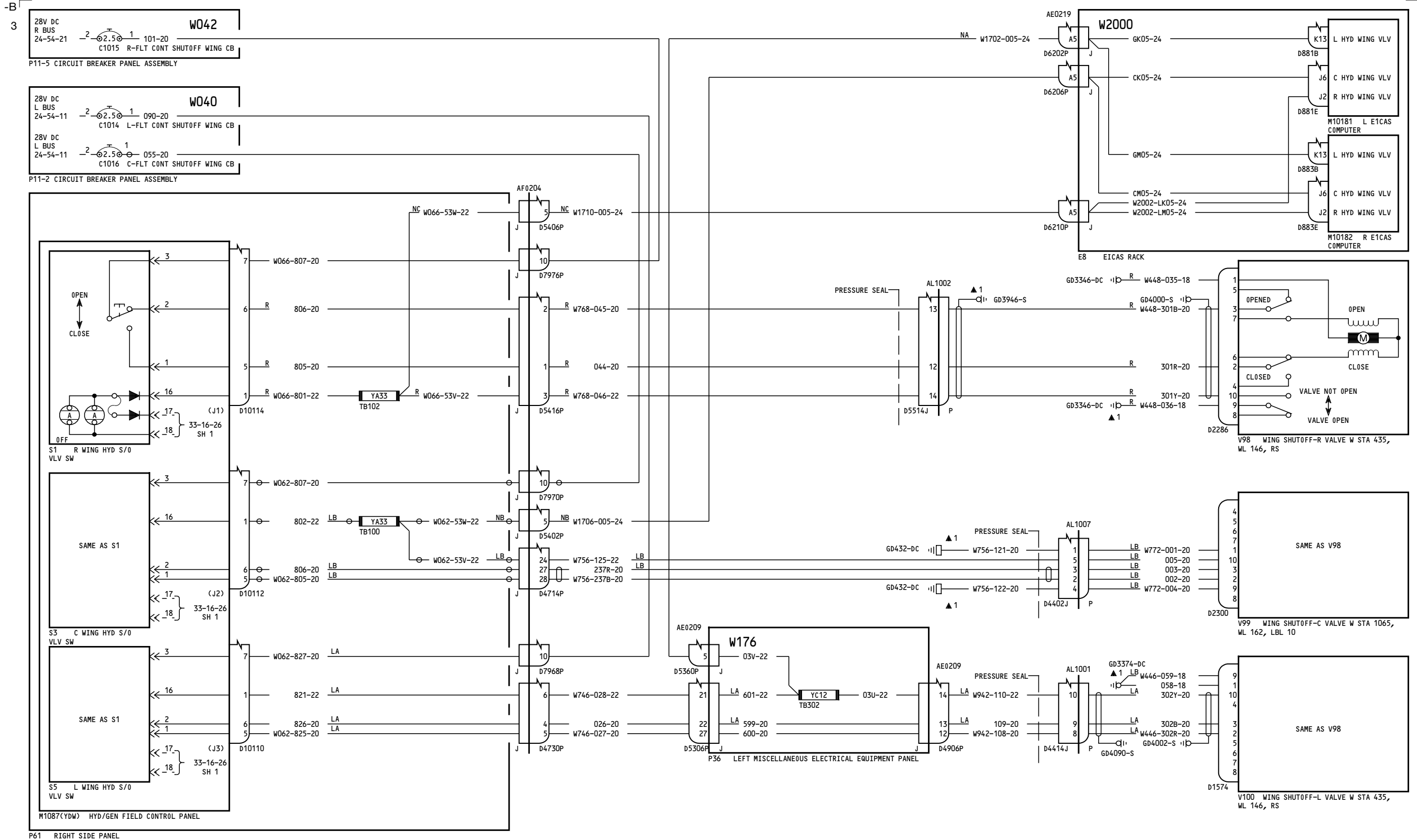

ALL

**AILERON & SPOILER  
HYDRAULIC SHUTOFF VALVES**

D280T132

**27-13-11**

Page 1

Jan 21/2005

**27-13-11**

Page 1

Jan 21/2005

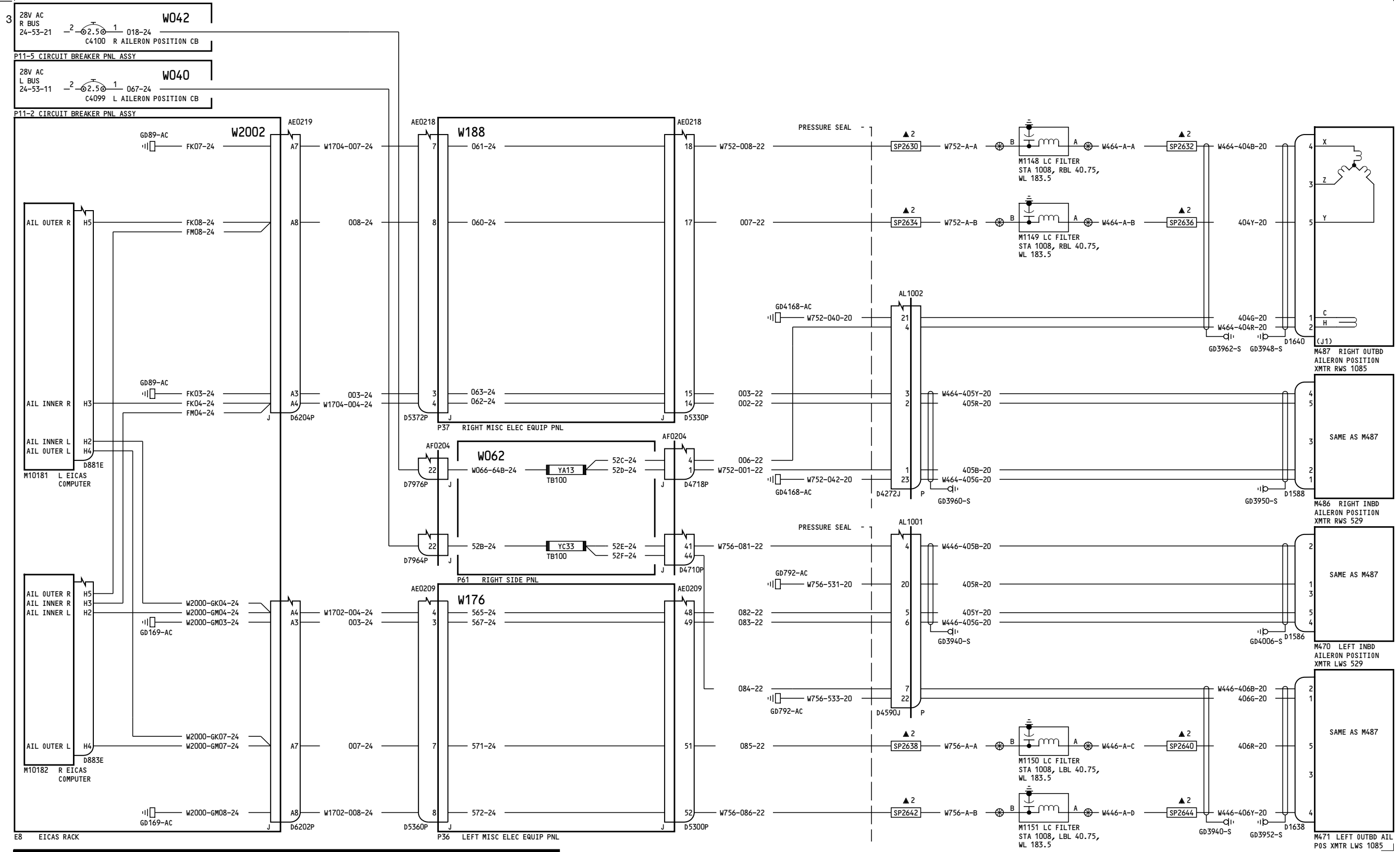

050-099

**AILERON POSITION INDICATION**

D280T132

**27-18-11**

Page 1  
Jan 21/2005

**27-18-11**

Page 1  
Jan 21/2005

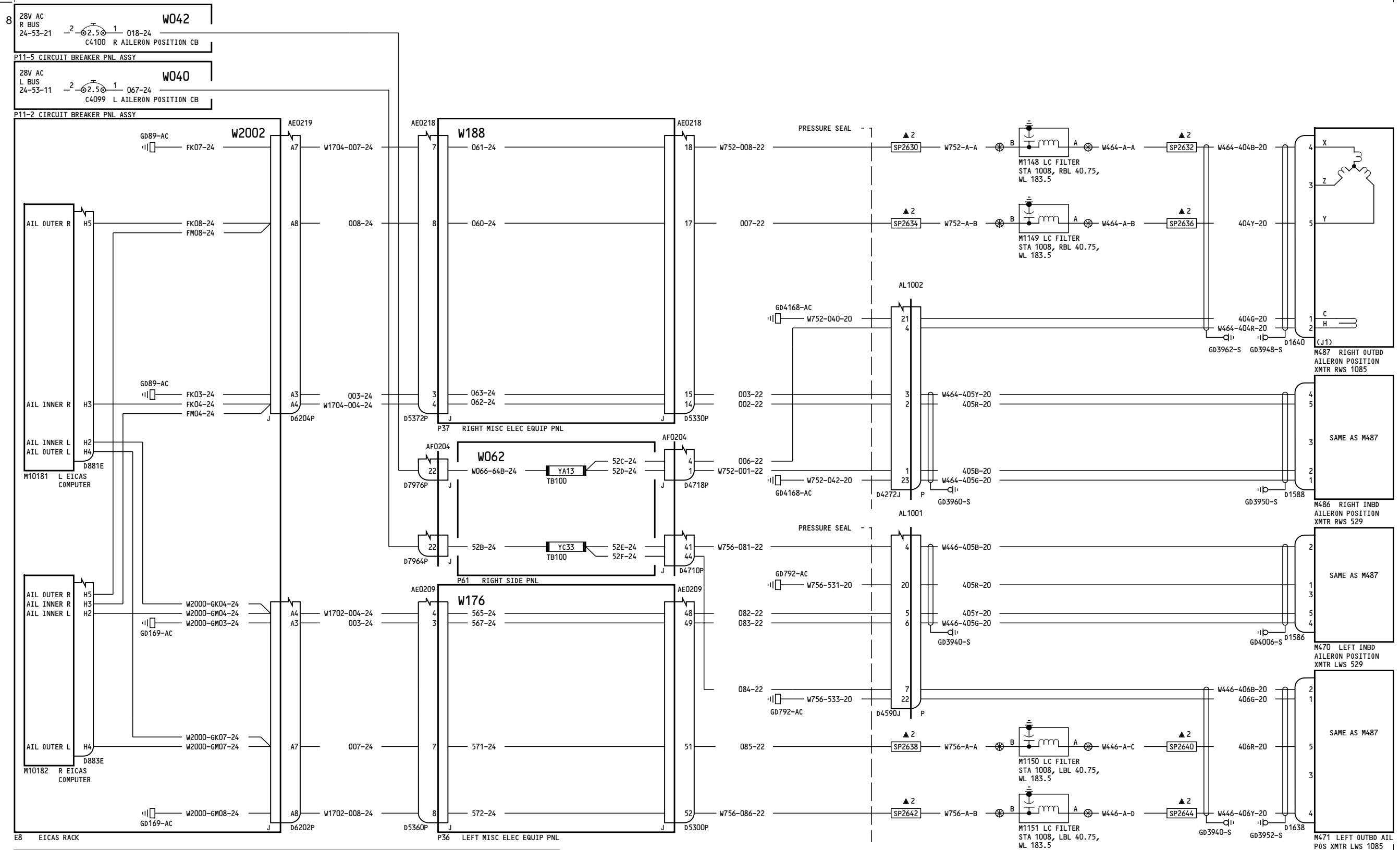

150-154, 162-165, 275-276

**AILERON POSITION INDICATION**

D280T132

27-18-11

Page 2

Jan 21/2005

27-18-11

Page 2

Jan 21/2005

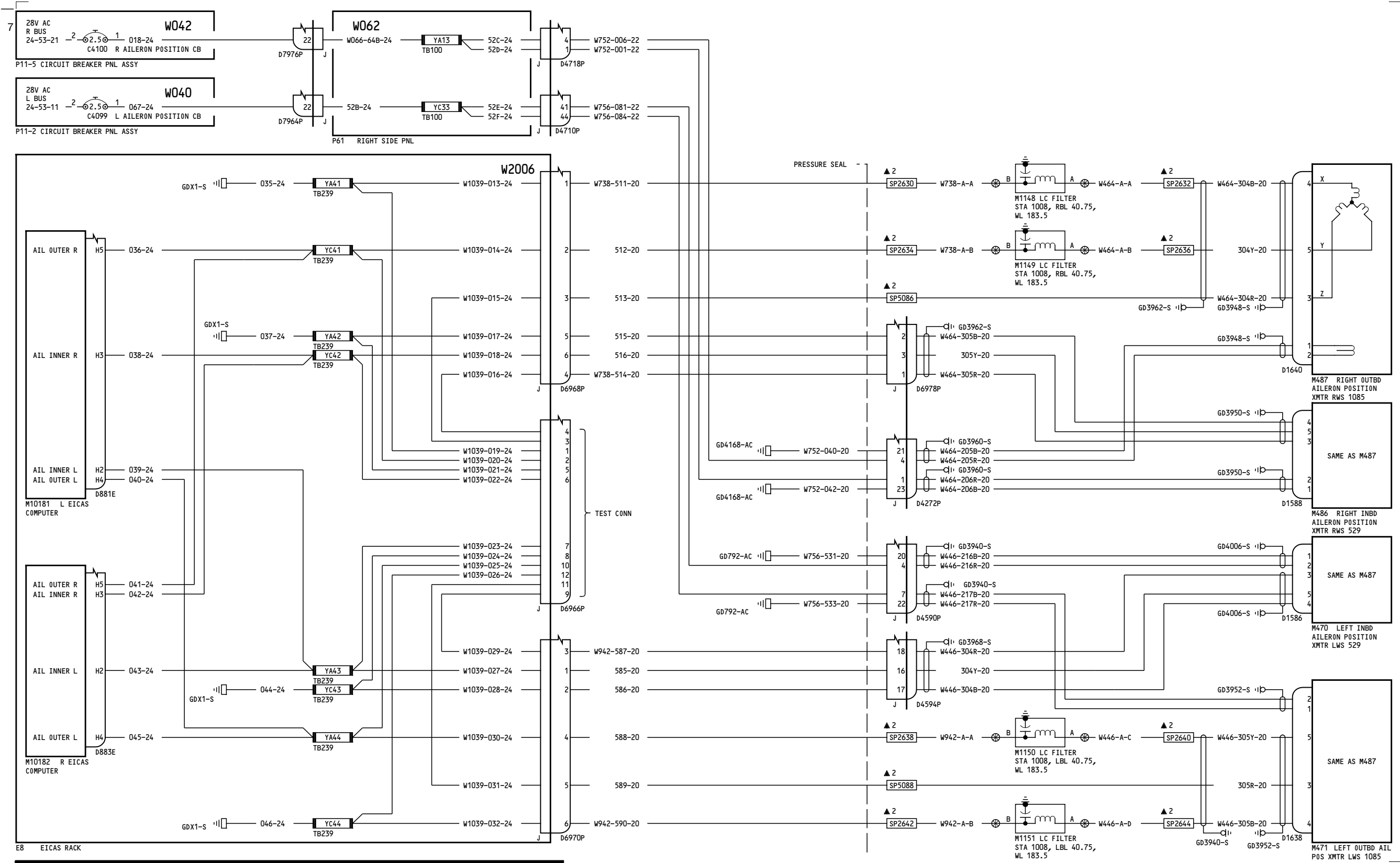

155-157, 166-199, 277-299

**AILERON POSITION INDICATION**

D280T132

27-18-11

Page 3

Jan 21/2005

27-18-11

Page 3

Jan 21/2005

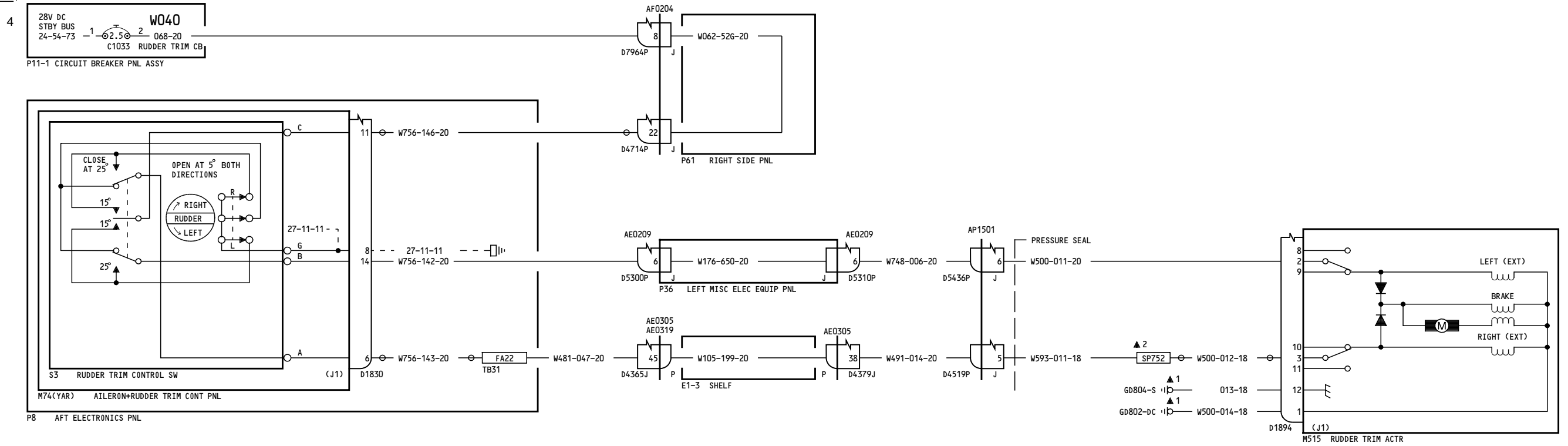

ALL	<p><b>RUDDER TRIM CONTROL</b></p> <p>D280T132</p>
-----	---

**27-21-11**  
 Page 1  
 Jan 21/2005

**27-21-11**  
 Page 1  
 Jan 21/2005

CONF 2

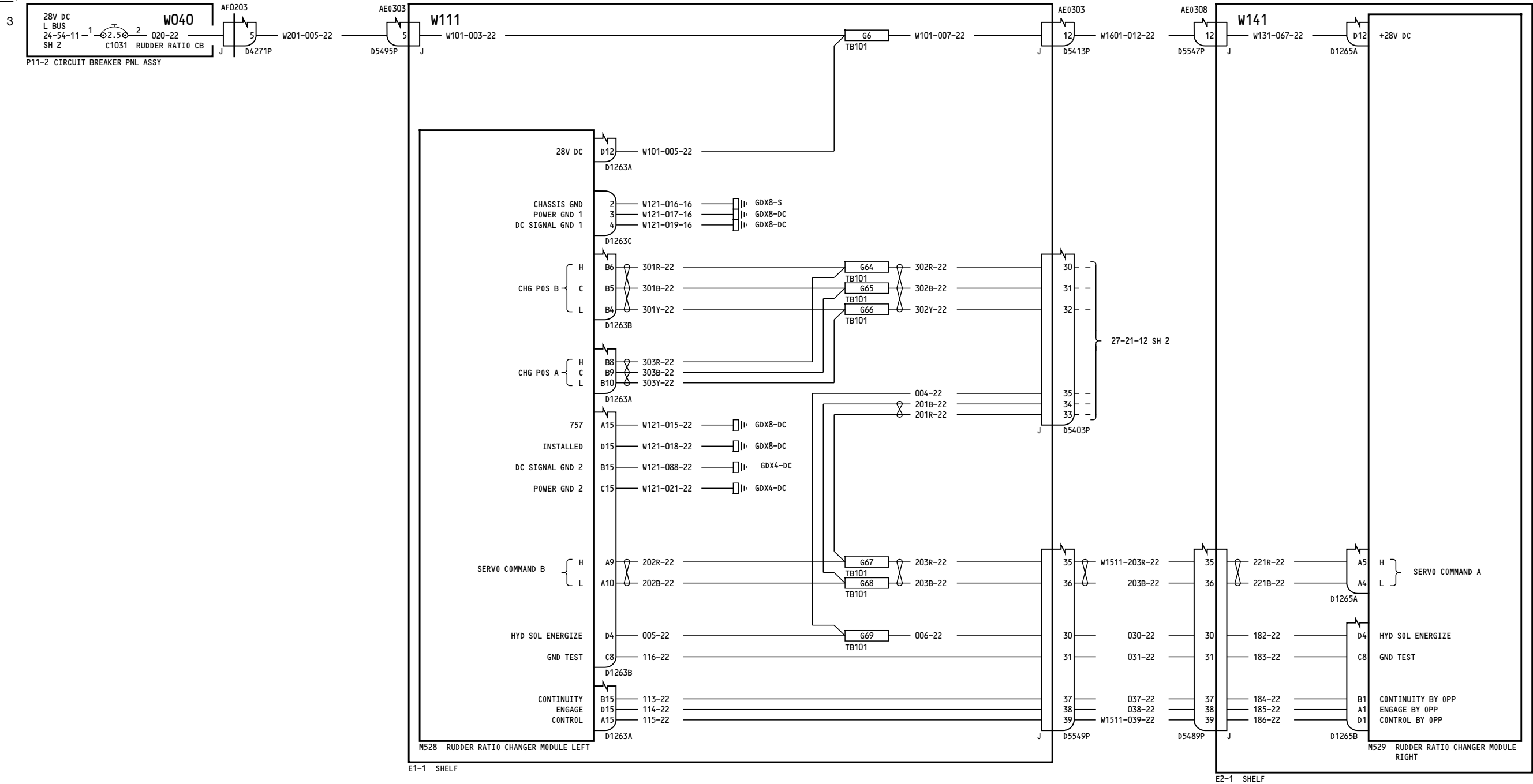

ALL

**RUDDER RATIO CHANGER-LEFT**

D280T132

**27-21-12**

Page 1  
Sheet 1  
Jan 21/2005

**27-21-12**

Page 1  
Sheet 1  
Jan 21/2005

3

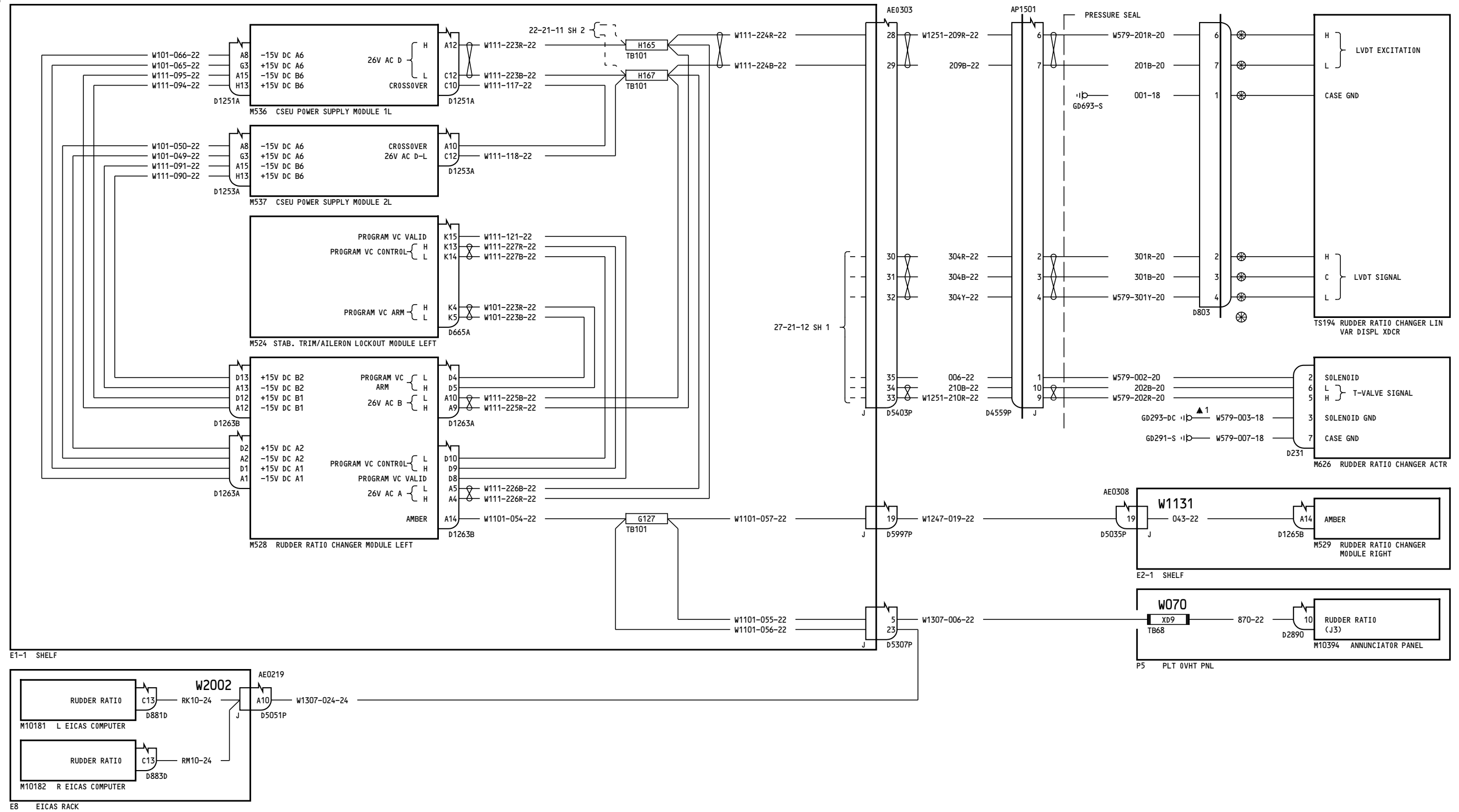

ALL

**RUDDER RATIO CHANGER-LEFT**  
D280T132

**27-21-12**  
Page 1  
Sheet 2  
Jan 21/2005

**27-21-12**  
Page 1  
Sheet 2  
Jan 21/2005



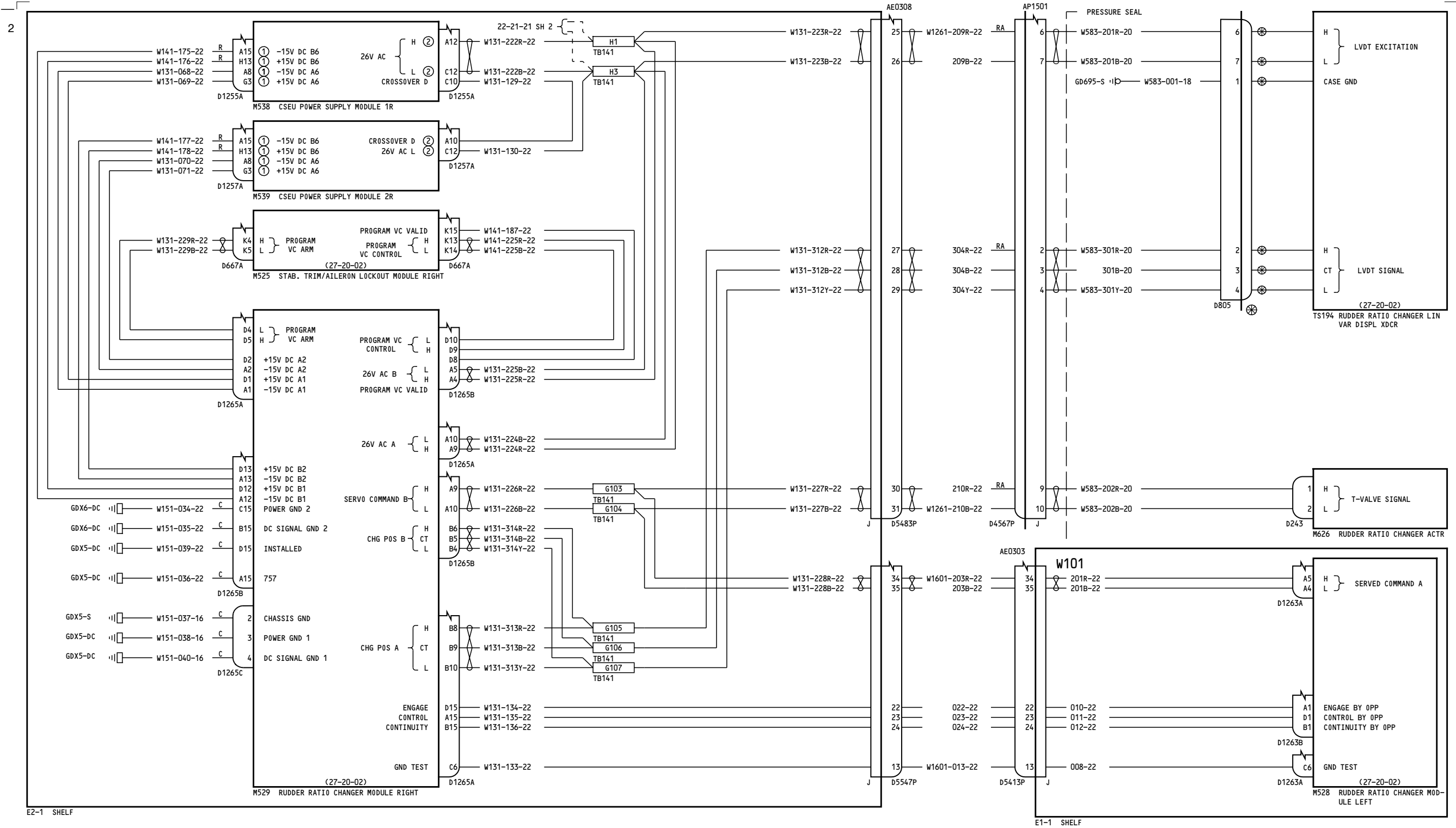

- NOTES:  
 ① 27-09-04  
 ② 27-09-02

ALL

**RUDDER RATIO CHANGER-  
RIGHT**

**27-21-22**

Page 1

D280T132

Jan 21/2005

**27-21-22**

Page 1

Jan 21/2005

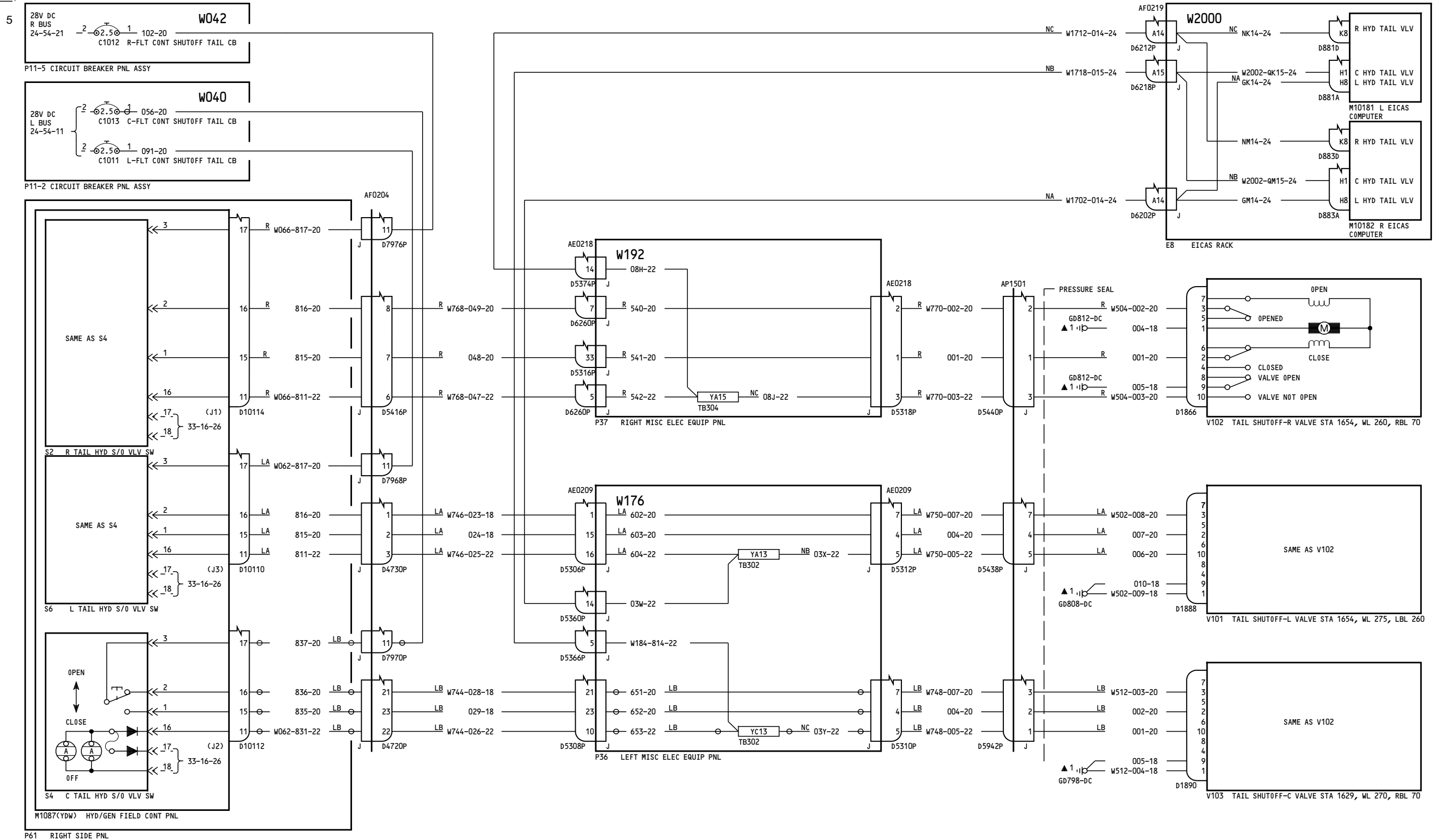

050-099

**TAIL HYDRAULIC SHUTOFF VALVES**

D280T132

**27-23-11**

Page 1  
Jan 21/2005

**27-23-11**

Page 1  
Jan 21/2005

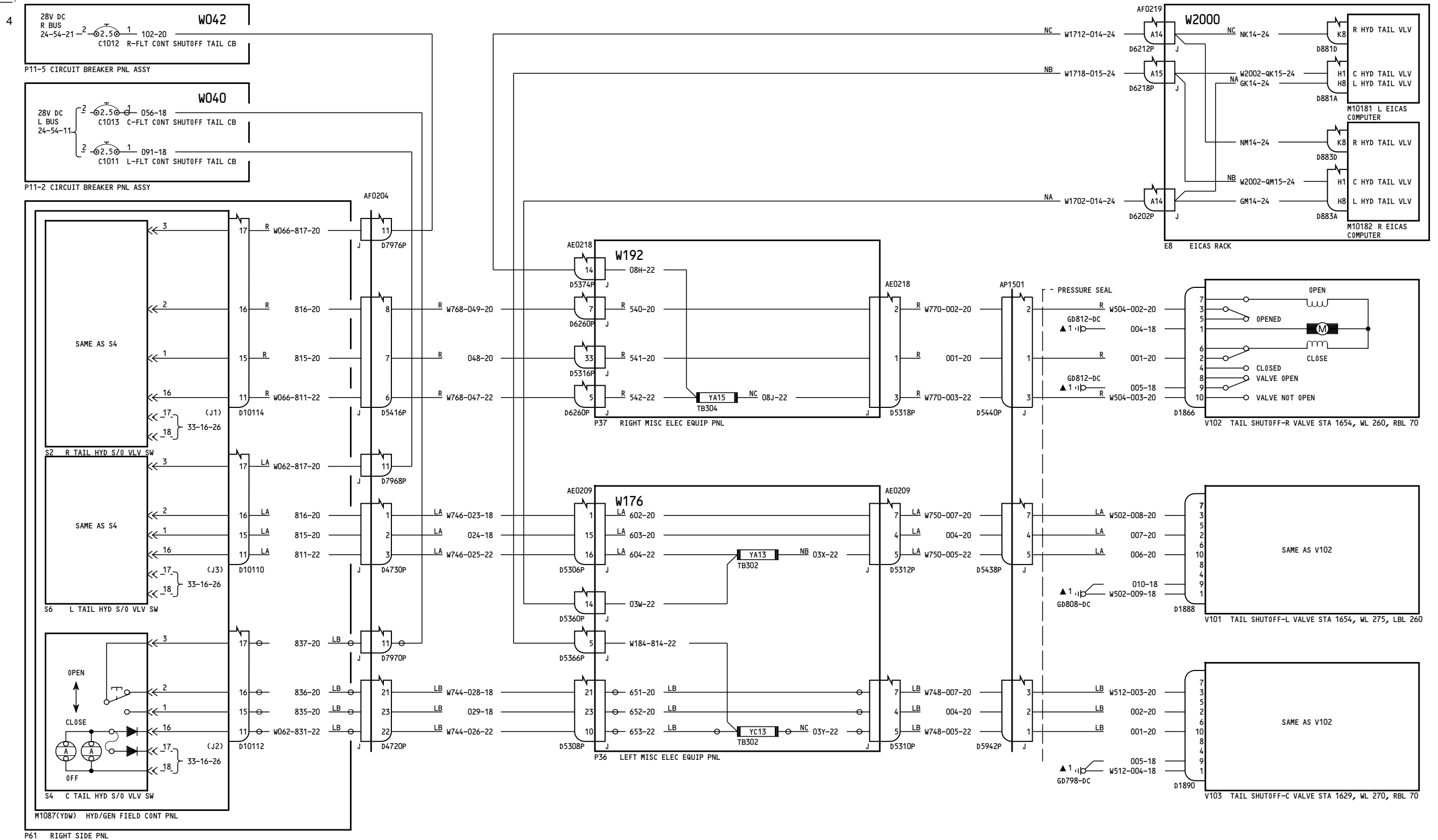

150-199, 275-299

**TAIL HYDRAULIC SHUTOFF VALVES**

**27-23-11**

Page 2

D280T132

Jan 21/2005

**27-23-11**

Page 2

Jan 21/2005

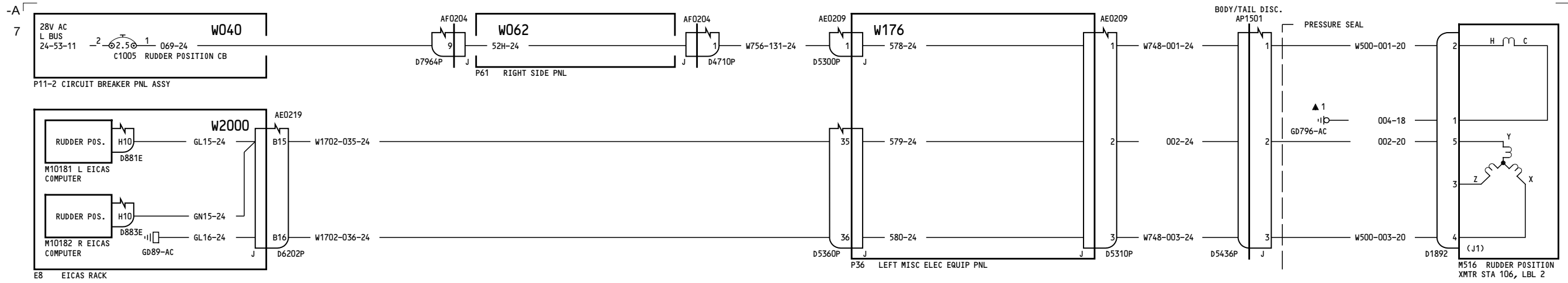

050-099

**RUDDER POSITION INDICATION**

**27-28-11**

Page 1

Jan 21/2005

D280T132

**27-28-11**

Page 1

Jan 21/2005

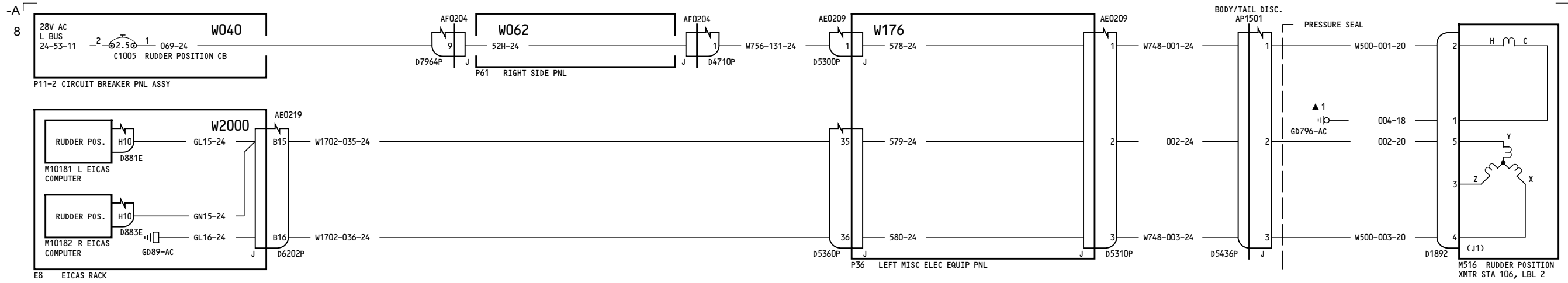

150-154, 162-165, 275-276

**RUDDER POSITION INDICATION**

**27-28-11**

Page 2

D280T132

Jan 21/2005

**27-28-11**

Page 2

Jan 21/2005

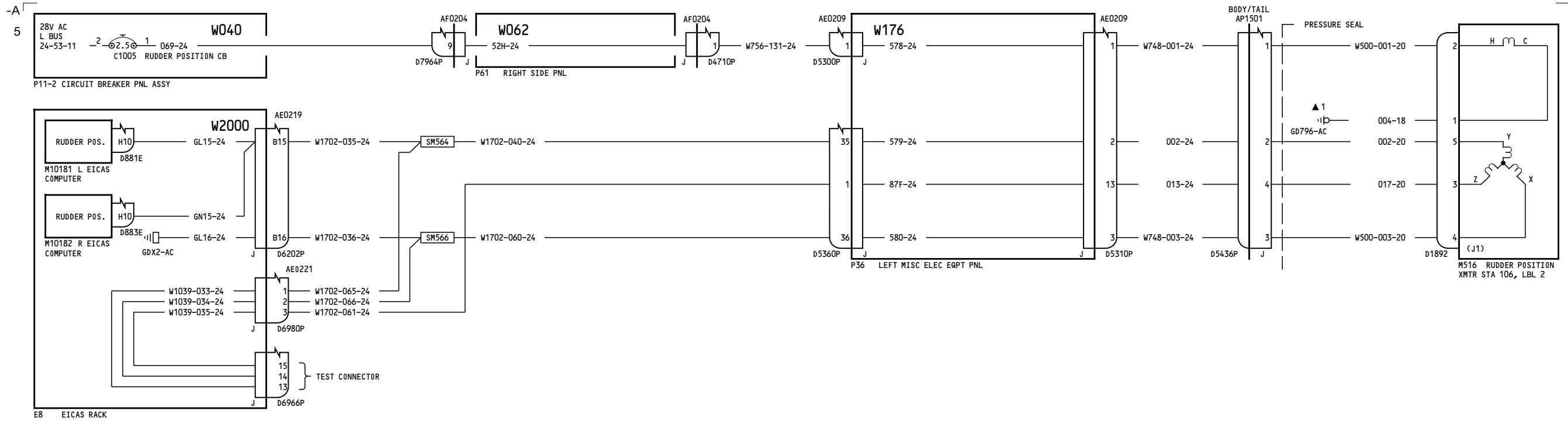

155-157, 166-199, 277-299

**RUDDER POSITION INDICATION**

**27-28-11**

Page 3

D280T132

Jan 21/2005

**27-28-11**

Page 3

Jan 21/2005

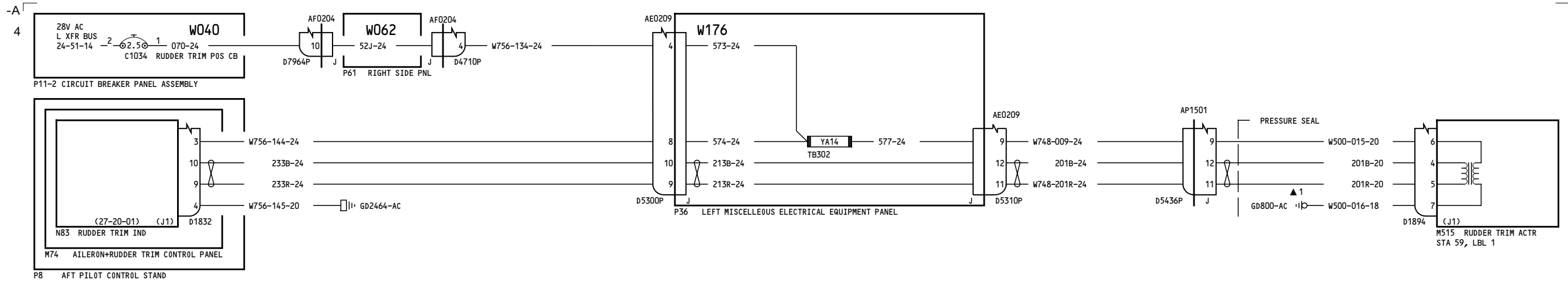

ALL	<p align="center"><b>RUDDER TRIM POSITION INDICATION</b></p> <p align="center">D280T132</p>
-----	---

**27-28-13**

Page 1

Jan 21/2005

**27-28-13**

Page 1

Jan 21/2005

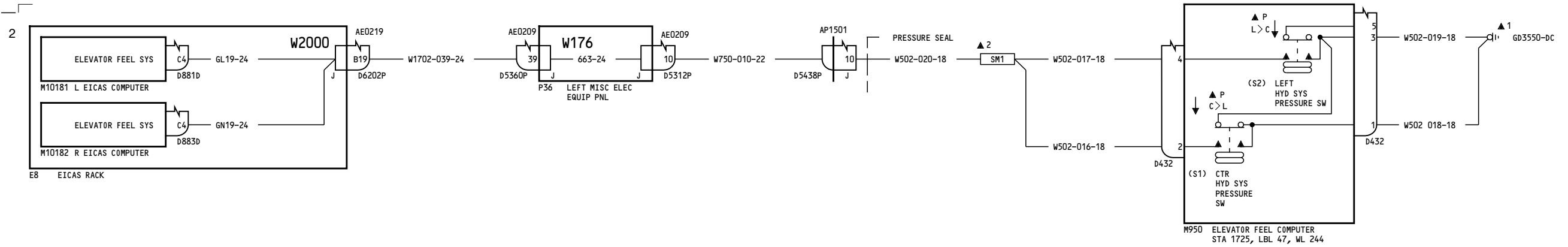

ALL

**ELEVATOR FEEL WARNING INDICATION**

**27-31-11**

Page 1

D280T132

Jan 21/2005

**27-31-11**

Page 1

Jan 21/2005



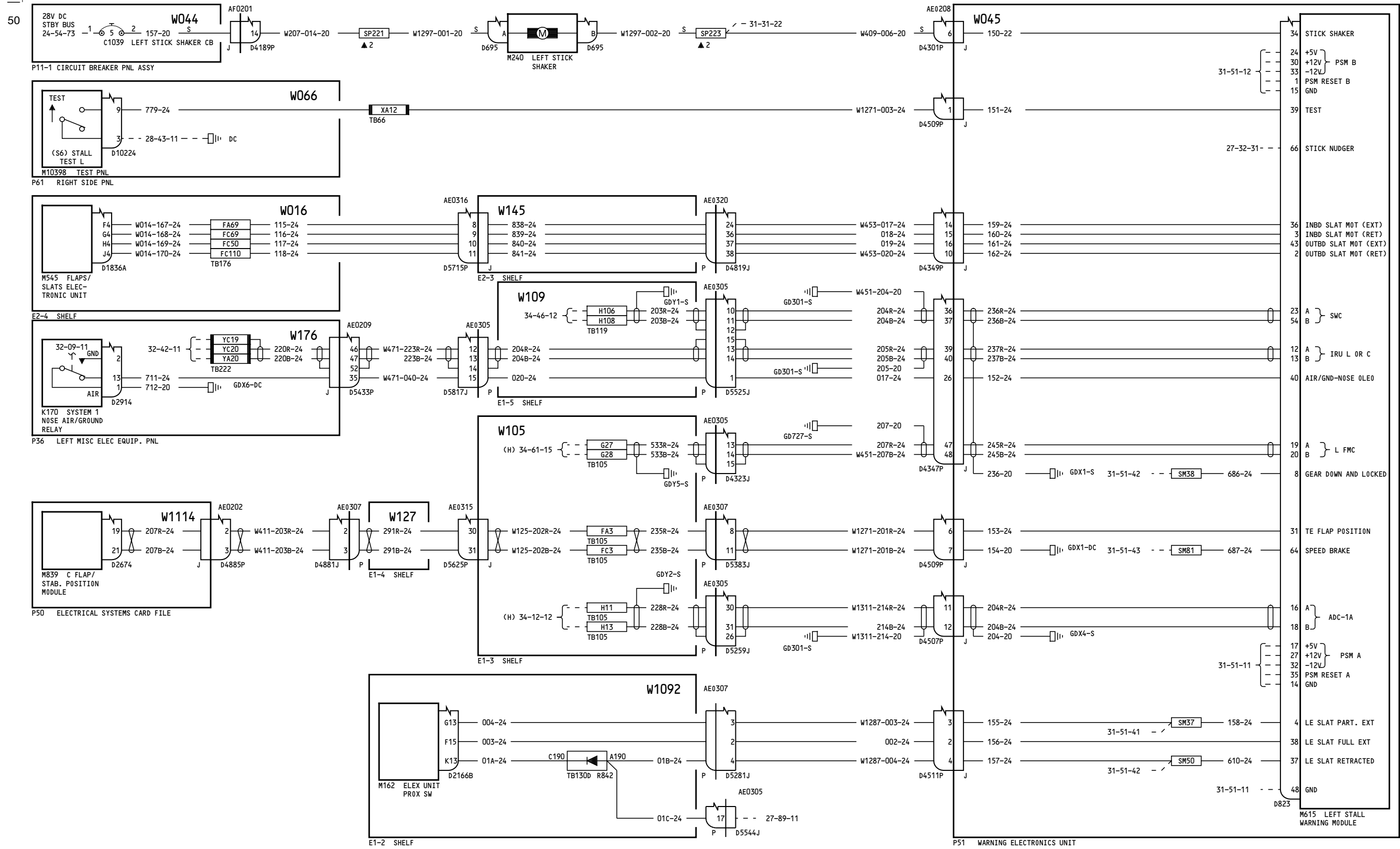

050-099

**WEU STALL WARNING-LEFT**

D280T132

**27-32-11**

Page 1

Jan 21/2005

Page 1

Jan 21/2005

**27-32-11**

Page 1

Jan 21/2005

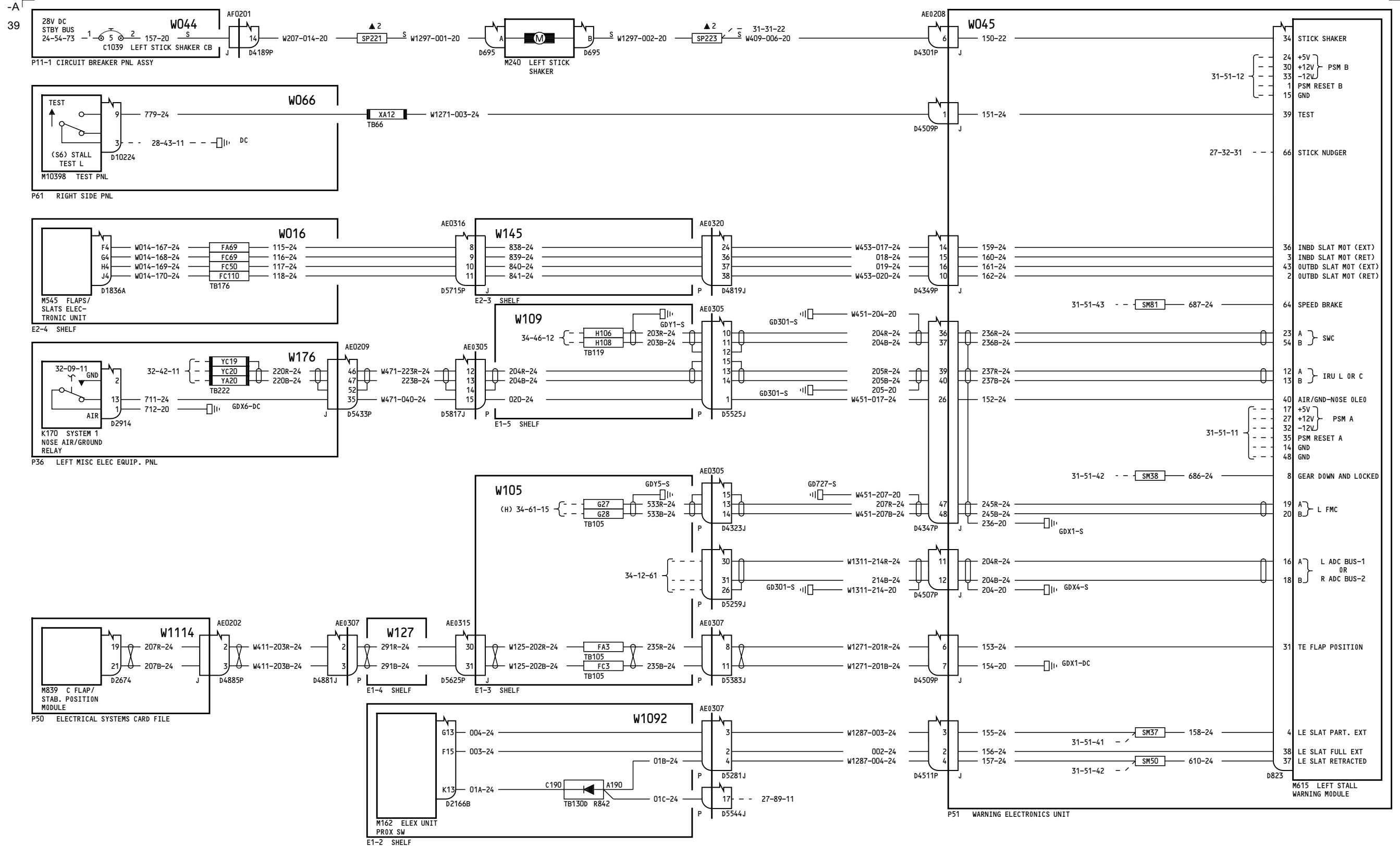

050-051

**WEU STALL WARNING-LEFT**

**27-32-11**

Incorporates  
34A0332 R02

Page 1.1

D280T132

May 20/2005

**27-32-11**

Page 1.1

May 20/2005

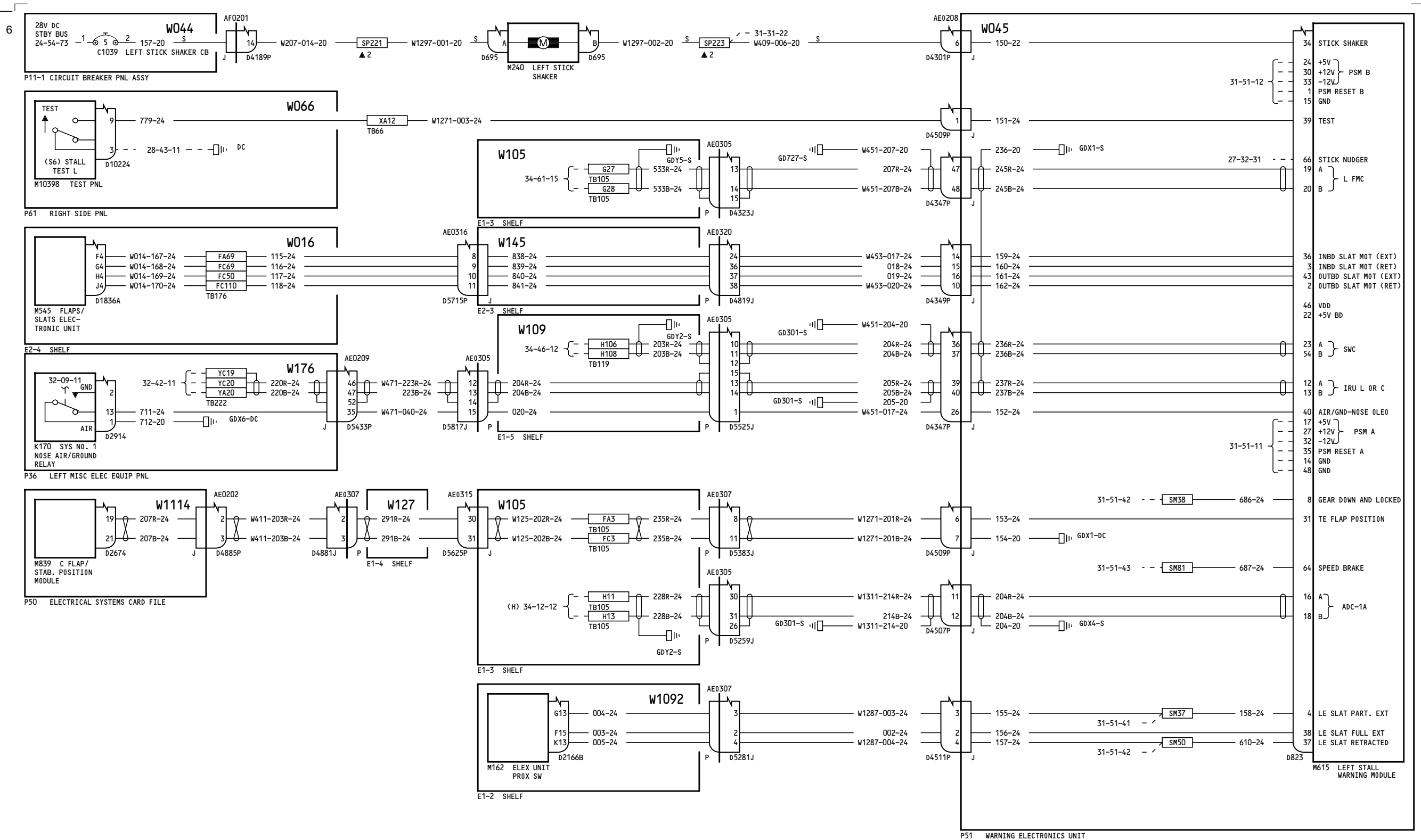

151

**WEU STALL WARNING-  
LEFT**

**27-32-11**

Page 2

D280T132

Jan 21/2005

**27-32-11**

Page 2

Jan 21/2005



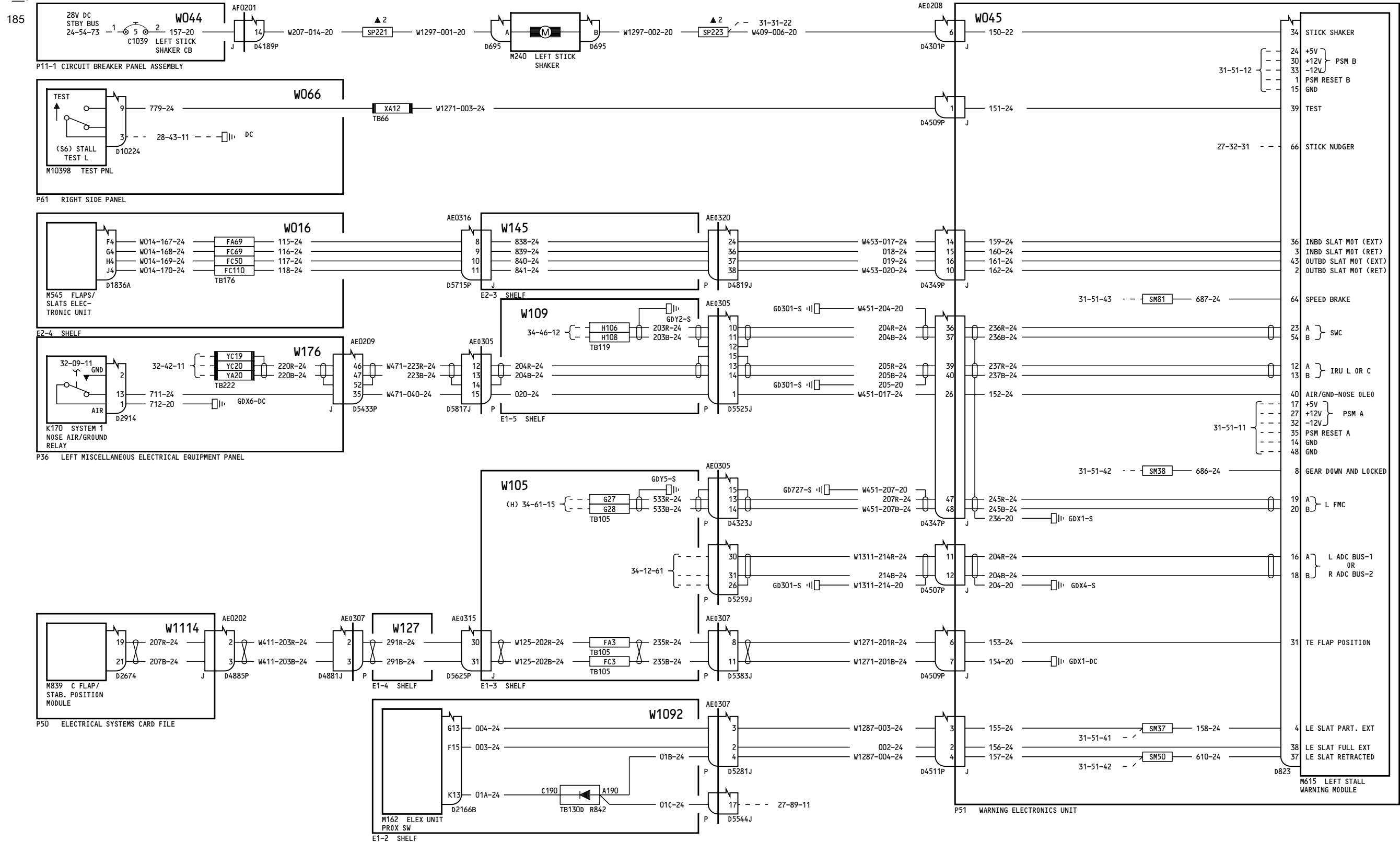

150-167

WEU STALL WARNING-LEFT

27-32-11

Page 2.2

D280T132

May 20/2005

Incorporates 27A0140 34A0332 R02

27-32-11

Page 2.2

May 20/2005

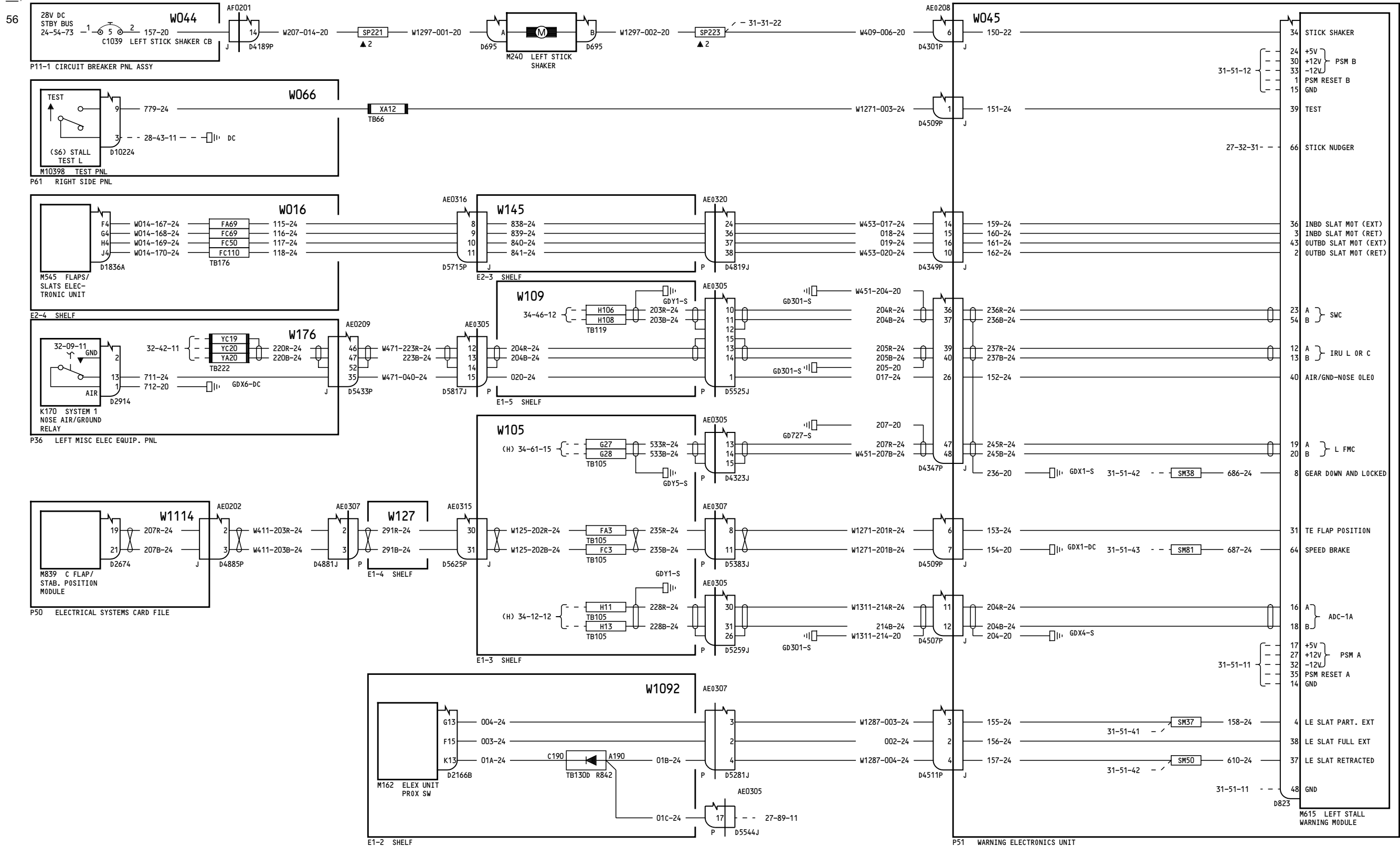

275-276

WEU STALL WARNING-LEFT

27-32-11

Page 3.1

D280T132

Jan 21/2005

Incorporates 27A0140

27-32-11

Page 3.1

Jan 21/2005

217

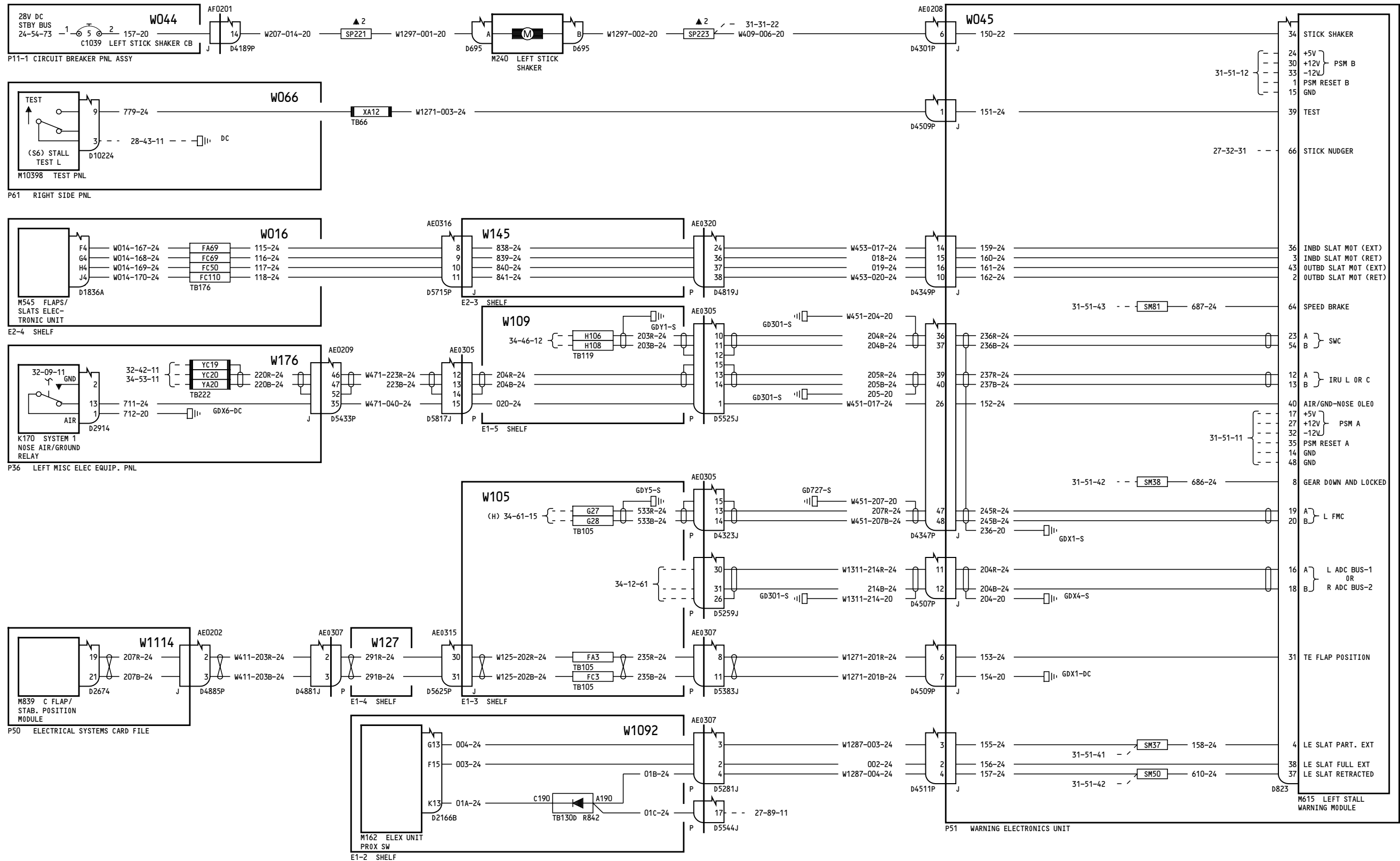

275-278

WEU STALL WARNING-LEFT

27-32-11

Page 3.2A

D280T132

Mar 14/2007

- Incorporates
- 27A0140
- 34A0332 R02
- EOC EEB34-0360-02

27-32-11

Page 3.2A

Mar 14/2007

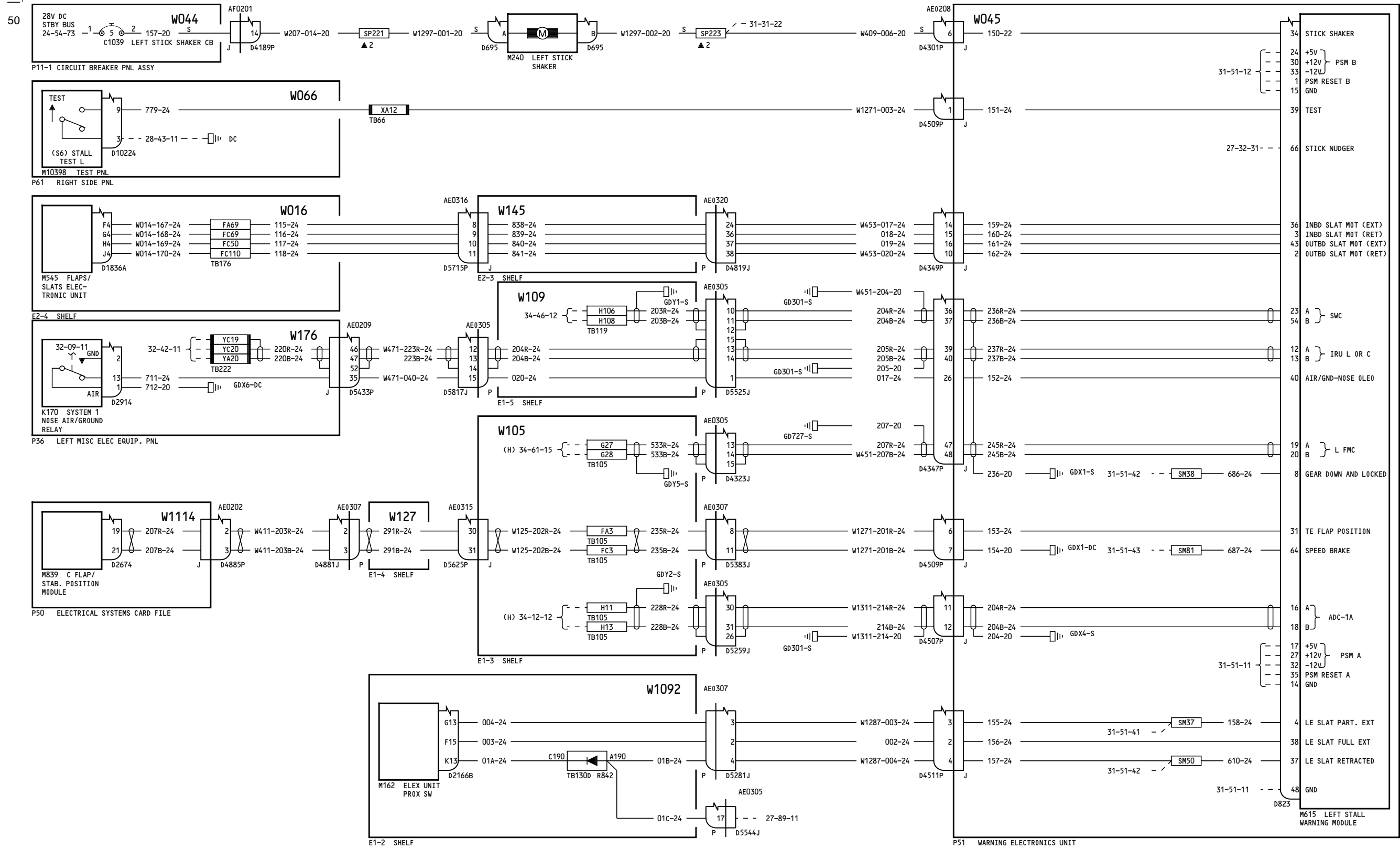

277-278

**WEU STALL WARNING-LEFT**

**27-32-11**

Page 3.3

May 20/2005

D280T132

Incorporates  
27A0140

**27-32-11**

Page 3.3

May 20/2005



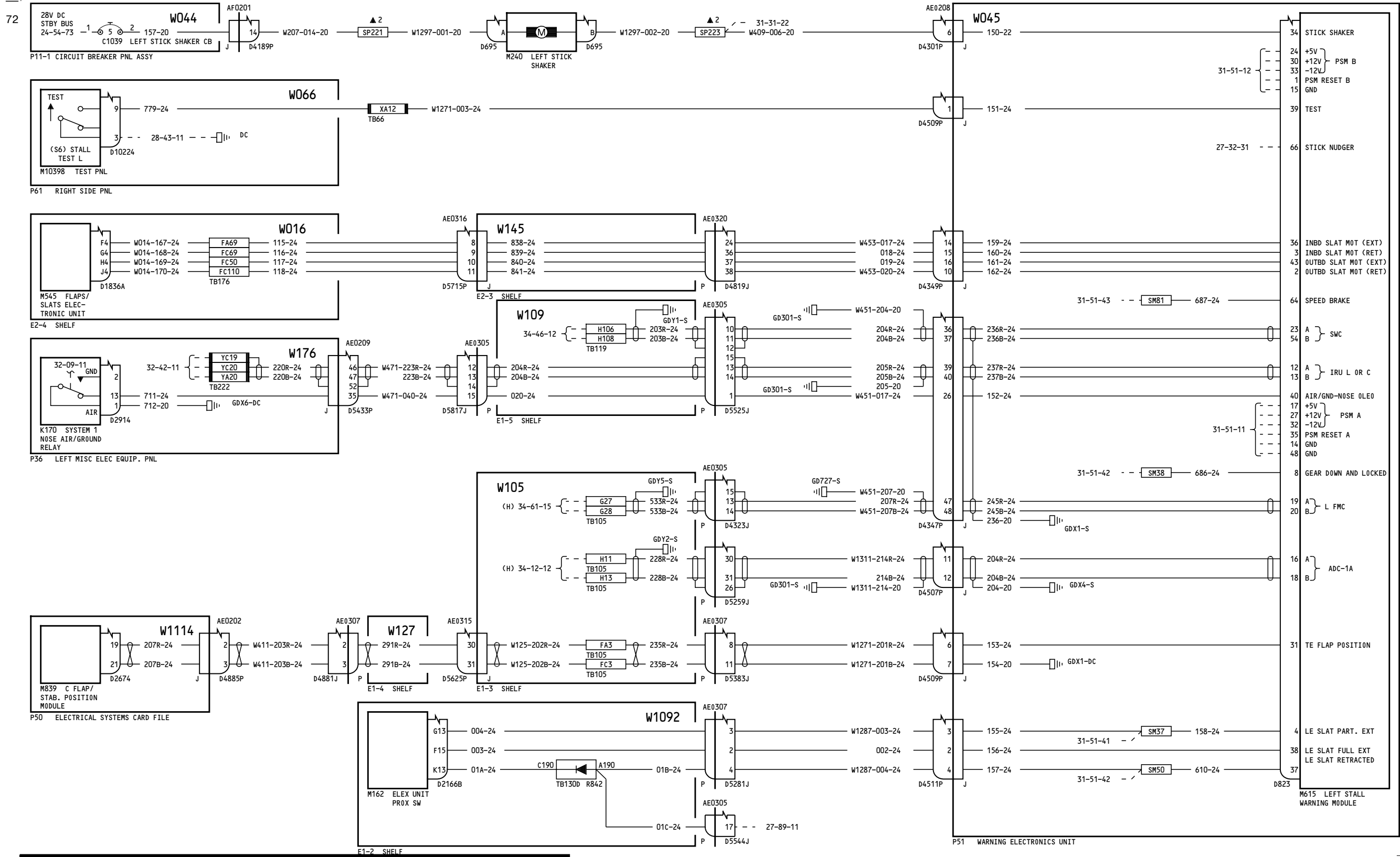

280

**WEU STALL WARNING-LEFT**  
D280T132

**27-32-11**  
Page 4.1  
May 20/2005

Incorporates  
27A0140 R01

**27-32-11**  
Page 4.1  
May 20/2005

217

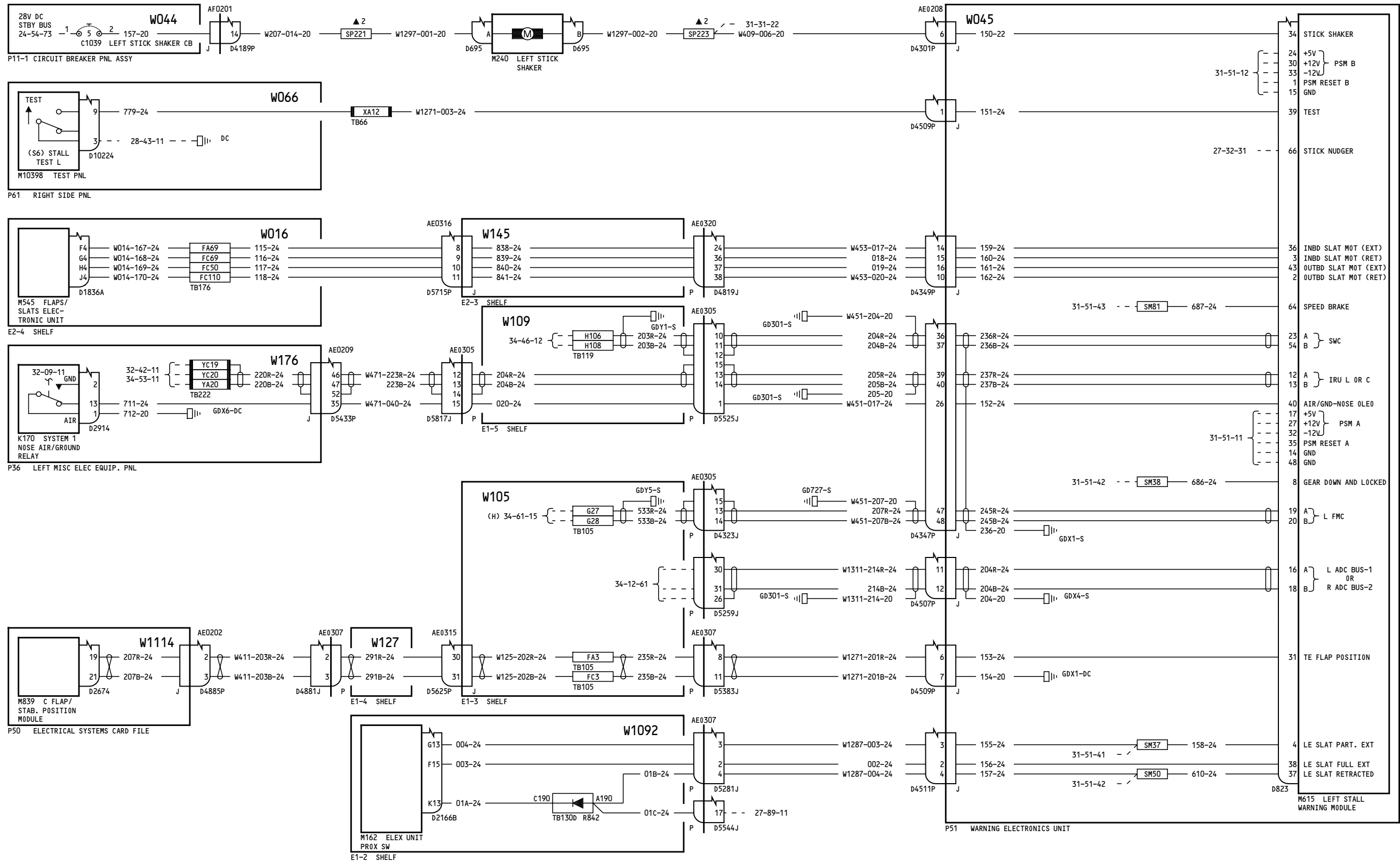

280

**WEU STALL WARNING-LEFT**

D280T132

**27-32-11**

Page 4.2A  
Mar 14/2007

- Incorporates
- 27A0140 R01
  - 34A0332 R02
  - EOC EEB34-0360-02

**27-32-11**

Page 4.2A  
Mar 14/2007

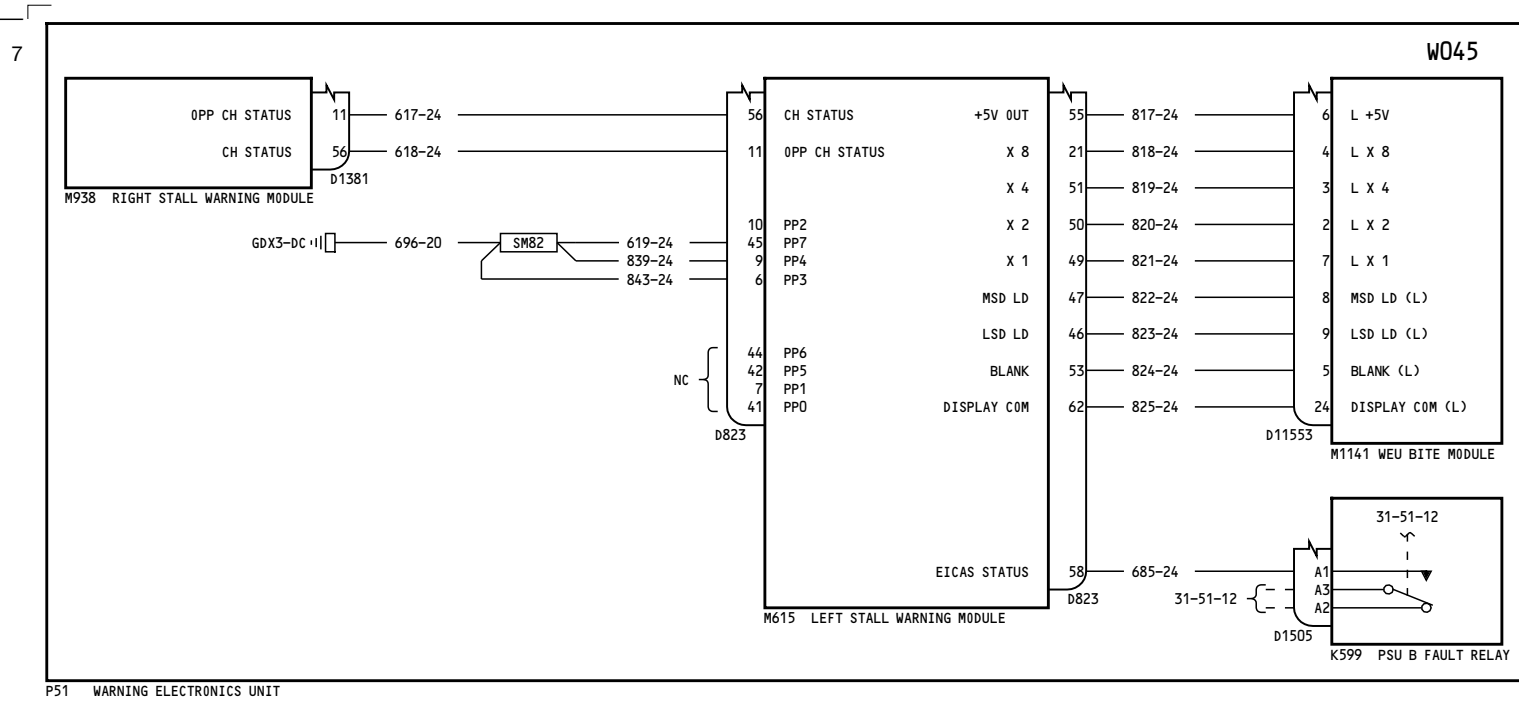

P51 WARNING ELECTRONICS UNIT

050-099

**WEU STALL WARNING  
BITE & STATUS-  
LEFT**

D280T132

**27-32-12**

Page 1

Jan 21/2005

**27-32-12**

Page 1

Jan 21/2005

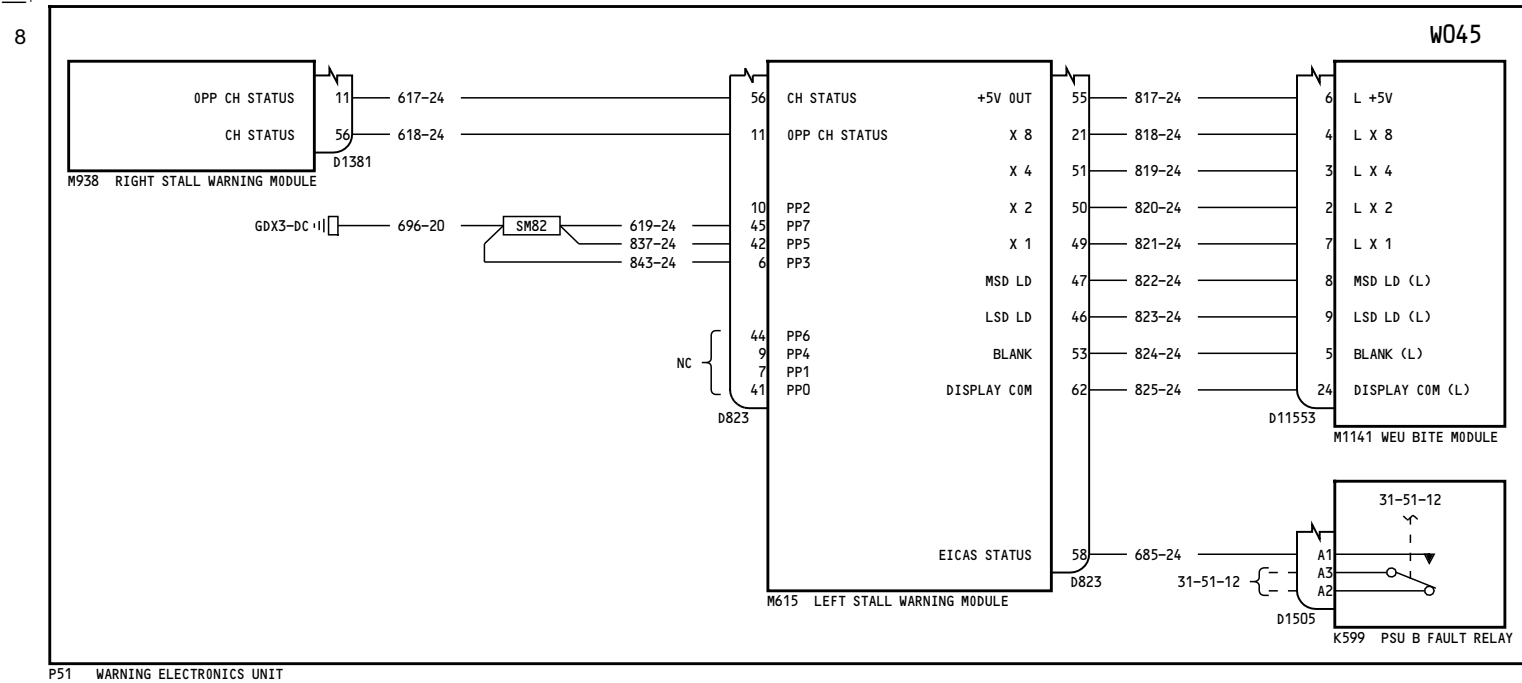

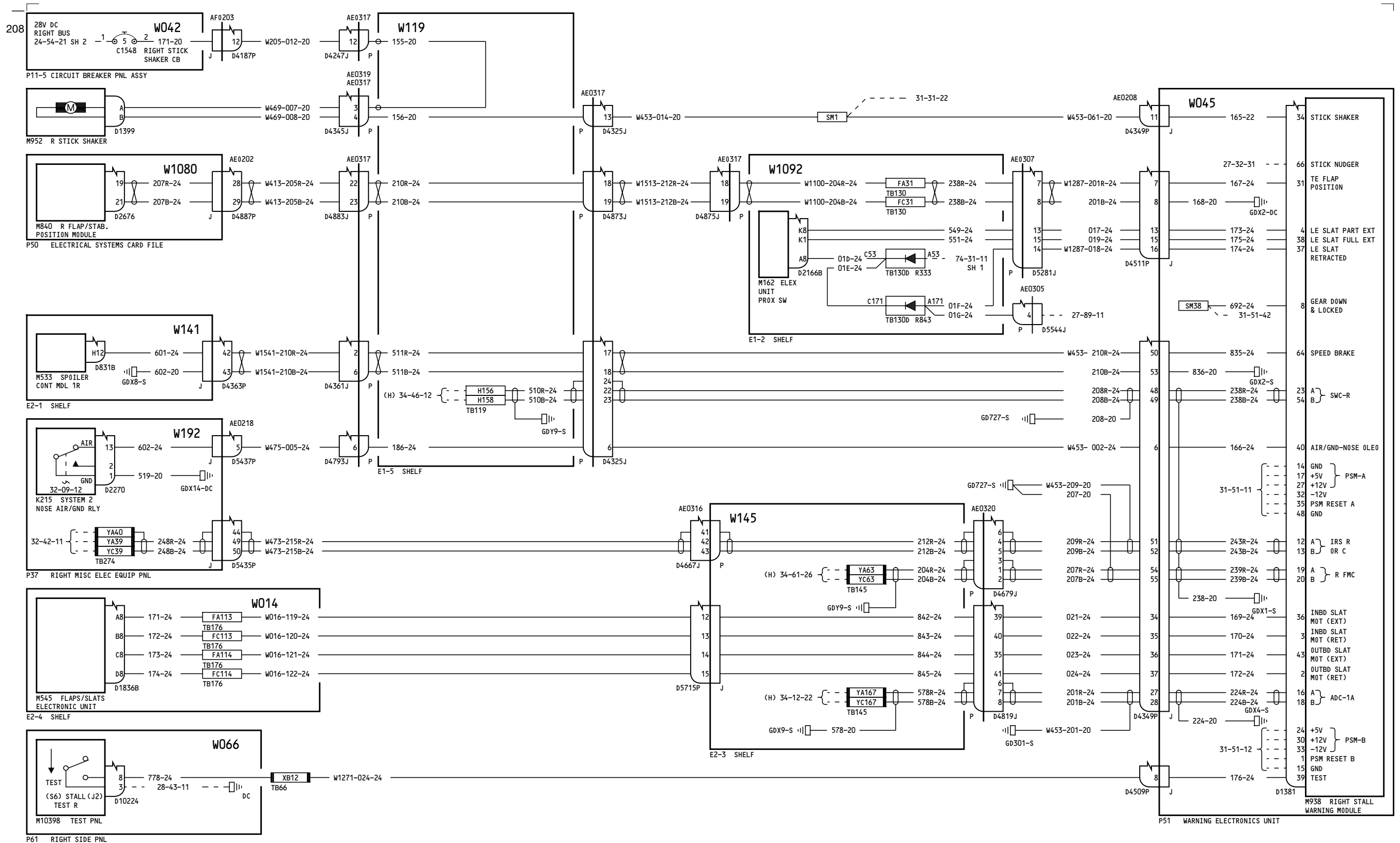

050

**WEU STALL WARNING-RIGHT**

D280T132

**27-32-21**

Page 1.1

Jan 21/2005

Incorporates  
34-0253 R01

**27-32-21**

Page 1.1

Jan 21/2005

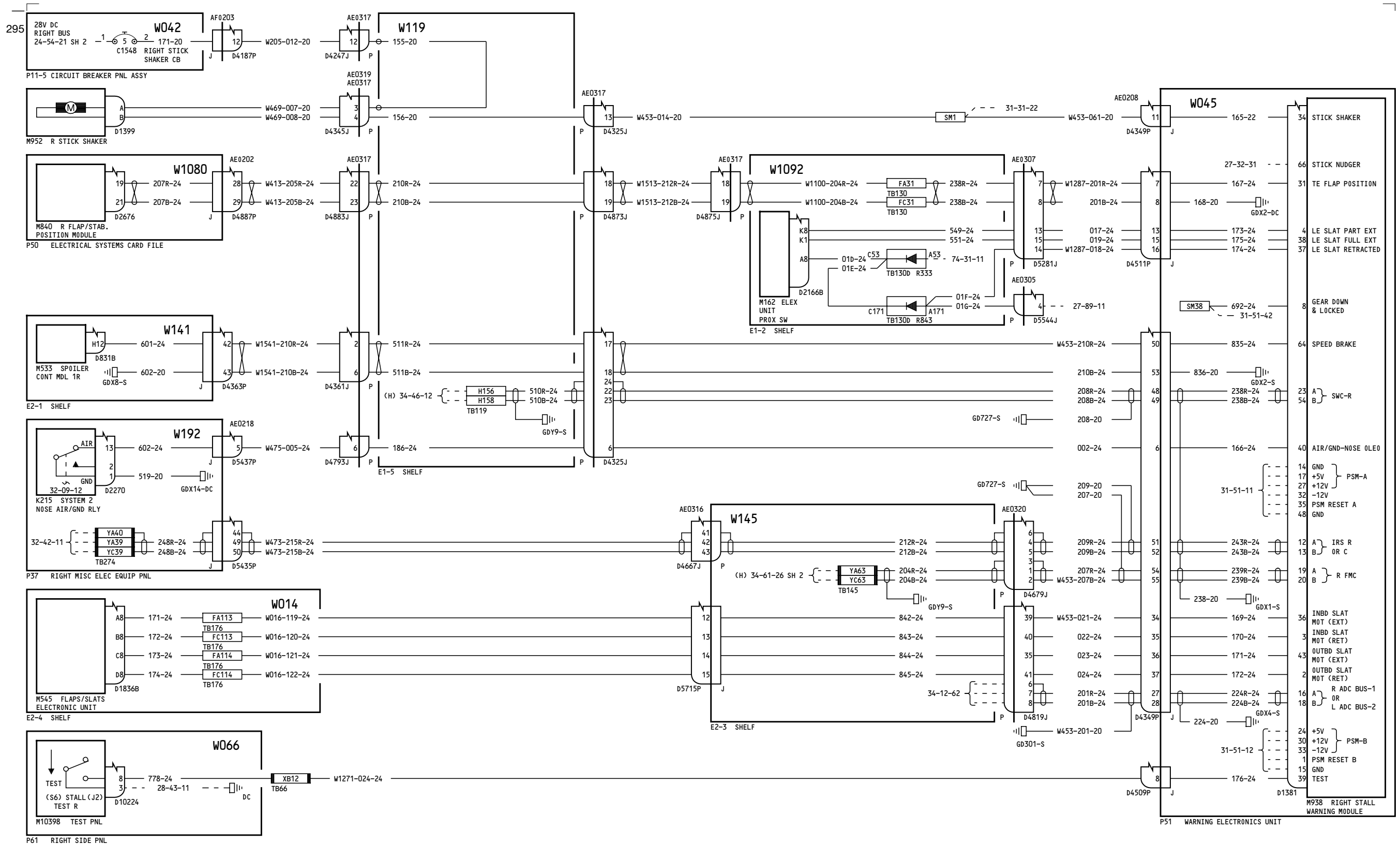

050

**WEU STALL WARNING-RIGHT**  
D280T132

**27-32-21**  
Page 1.2  
May 20/2005

Incorporates  
34-0253 R01  
34A0332 R02

**27-32-21**  
Page 1.2  
May 20/2005



767-200/300 WIRING DIAGRAM MANUAL

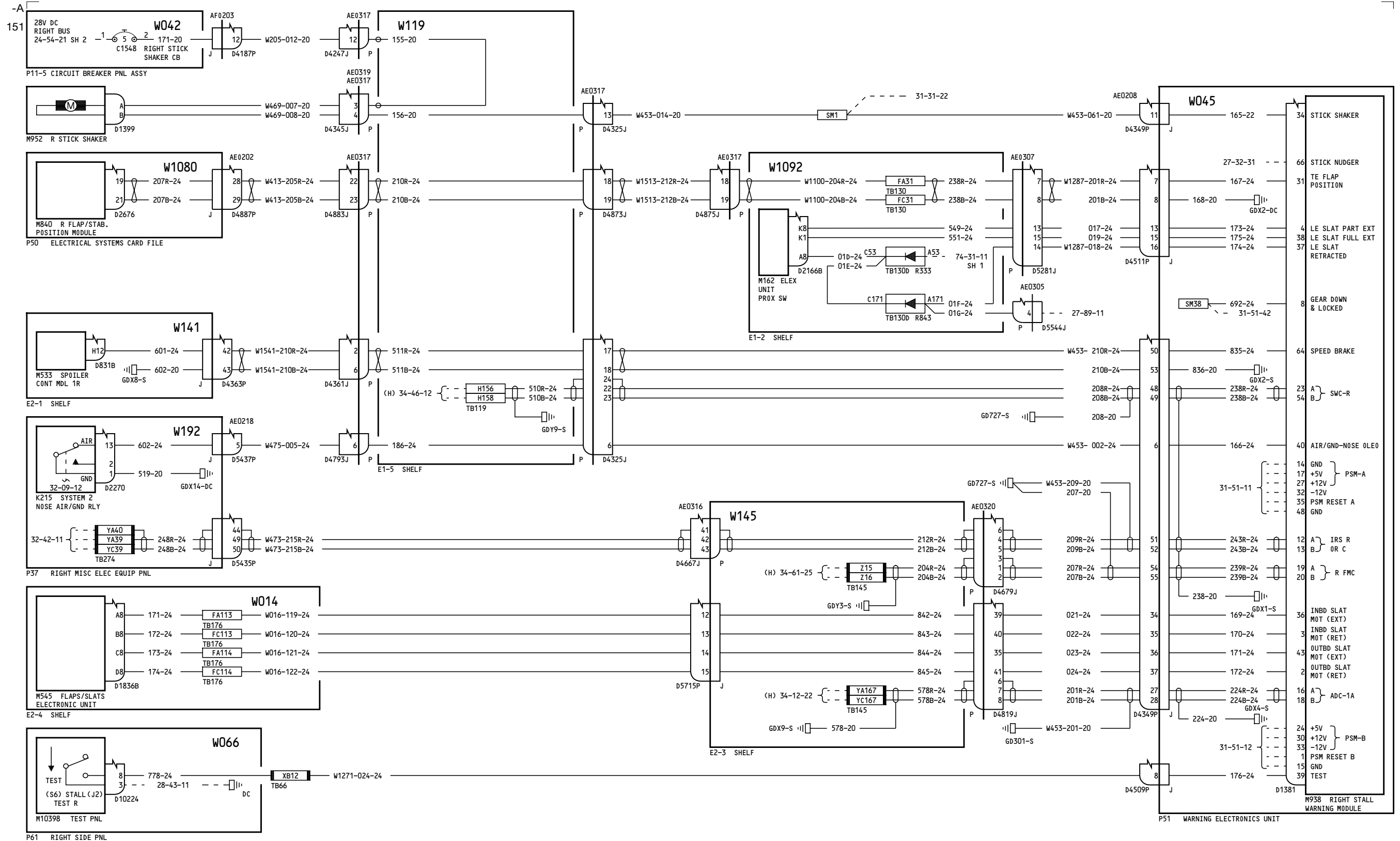

051-099	<b>WEU STALL WARNING-RIGHT</b>
	D280T132

27-32-21

Page 2

Jan 21/2005

27-32-21

Page 2

Jan 21/2005

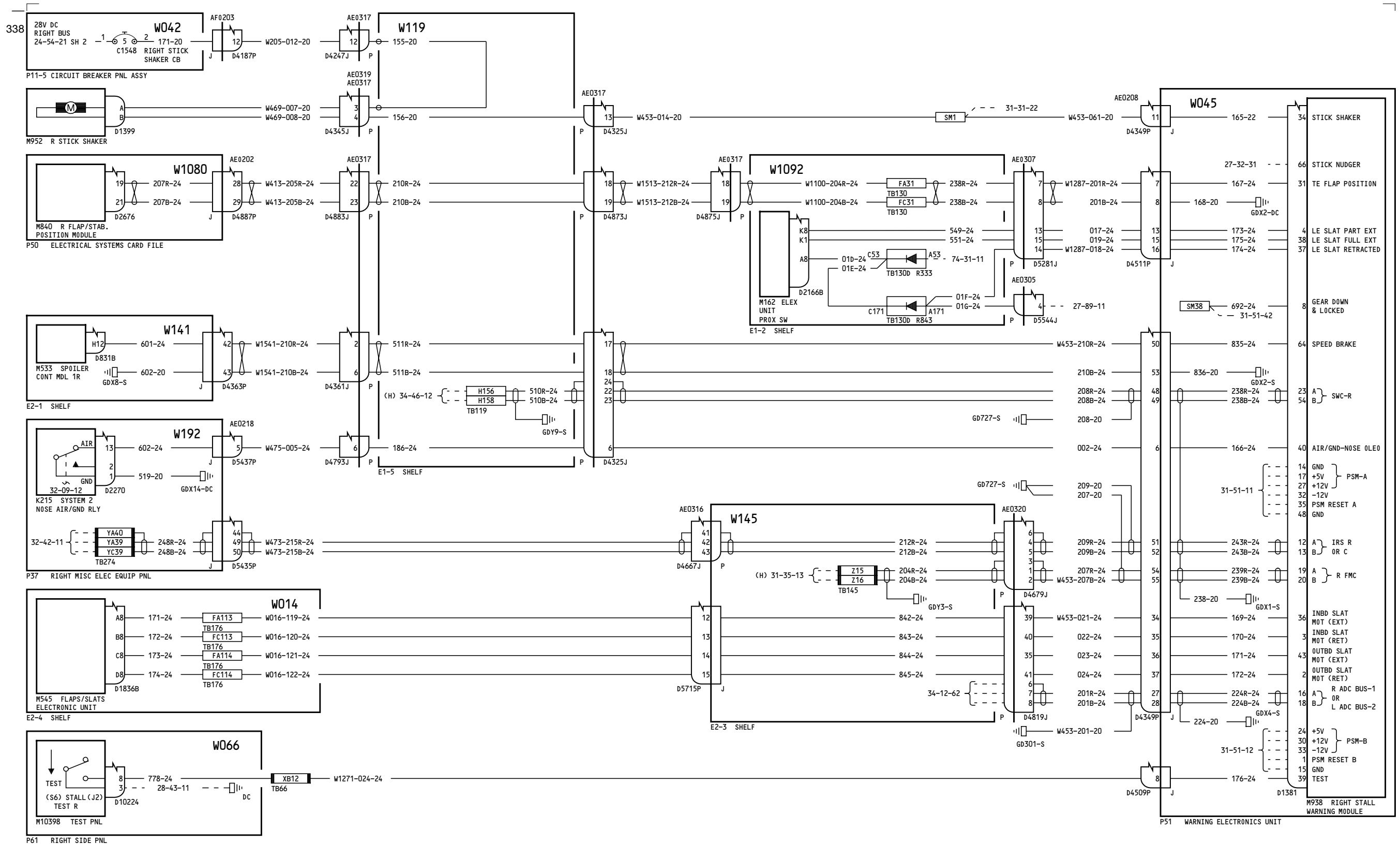

051

**WEU STALL WARNING-RIGHT**

D280T132

**27-32-21**

Page 2.1

May 20/2005

Incorporates  
34A0332 R02

**27-32-21**

Page 2.1

May 20/2005



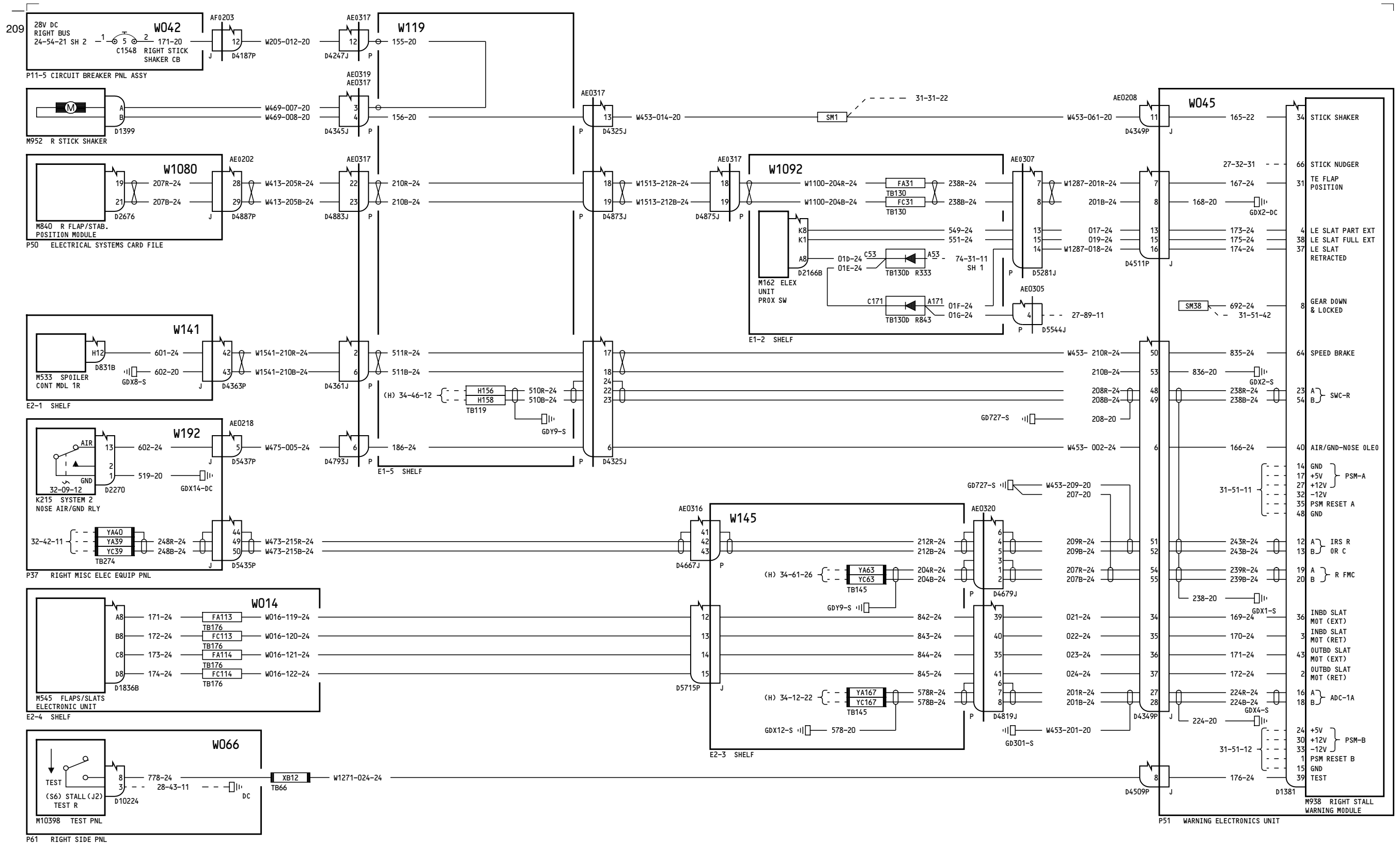

150, 152-154

**WEU STALL WARNING-RIGHT**

**27-32-21**

Incorporates  
 27A0140  
 34-0253 R01

**27-32-21**

Page 3.1

Page 3.1

D280T132

Jan 21/2005

Jan 21/2005

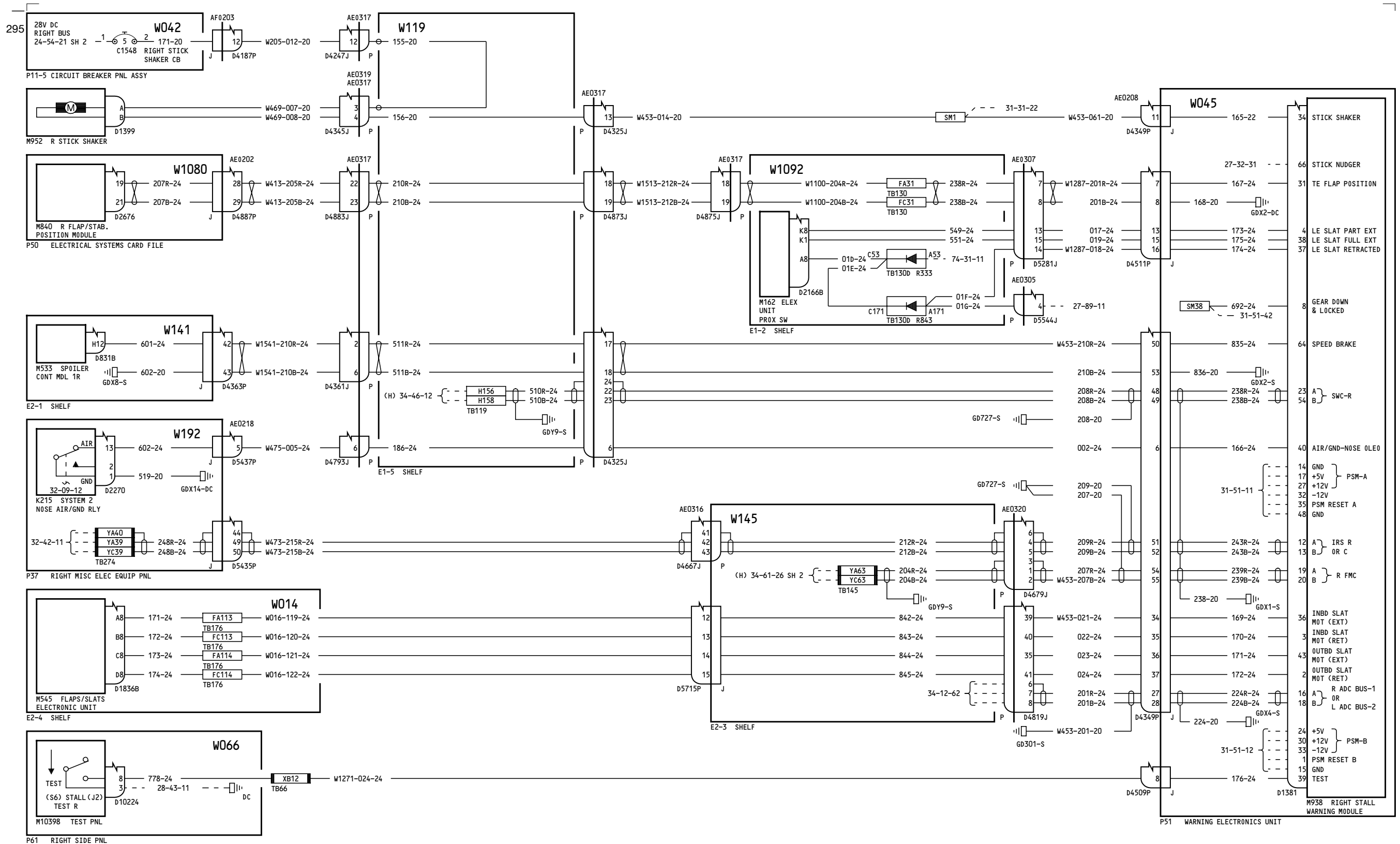

150, 152-157

**WEU STALL WARNING-RIGHT**

D280T132

**27-32-21**

Page 3.2

May 20/2005

- Incorporates
- ▶ 27A0140
  - ▶ 34-0253 R01
  - ▶ 34A0332 R02

**27-32-21**

Page 3.2

May 20/2005

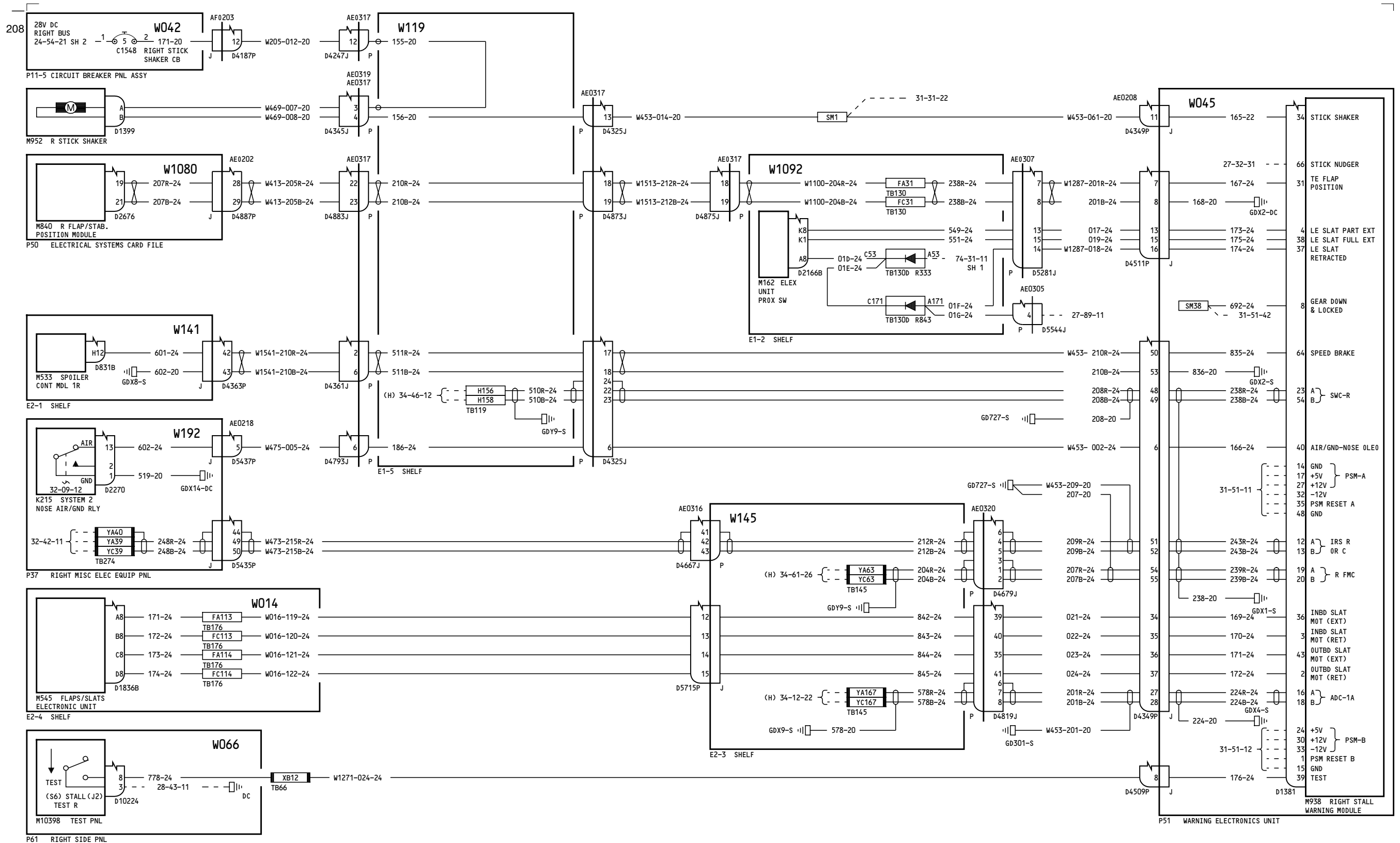

155-167

**WEU STALL WARNING-RIGHT**

D280T132

**27-32-21**

Page 3.3

May 20/2005

Incorporates

27A0140

34-0253 R01

**27-32-21**

Page 3.3

May 20/2005

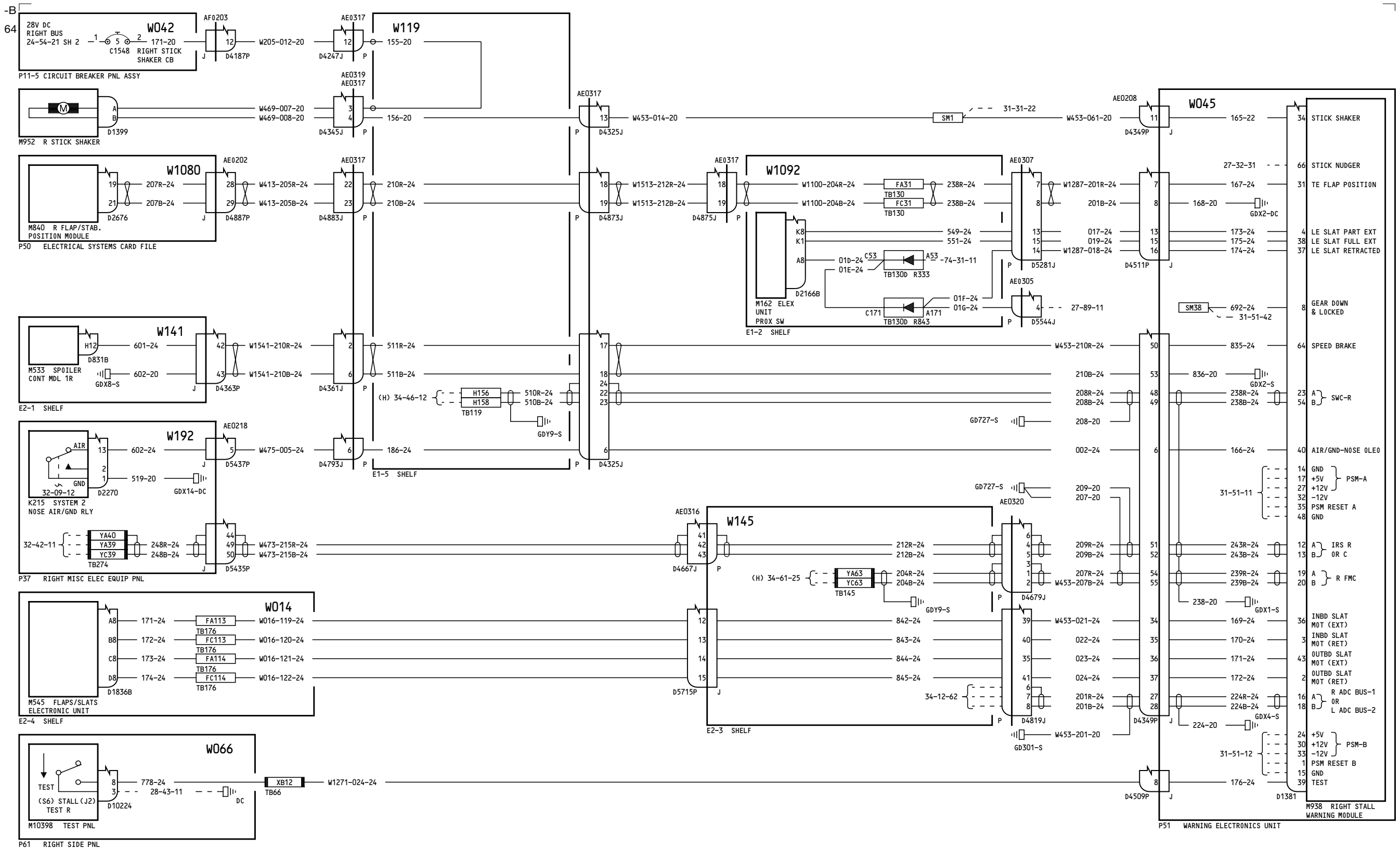

162-167

**WEU STALL WARNING-  
RIGHT**

D280T132

**27-32-21**

Page 3.4

May 20/2005

Incorporates  
 27A0140  
 34-0253 R01  
 34A0332 R02

**27-32-21**

Page 3.4

May 20/2005

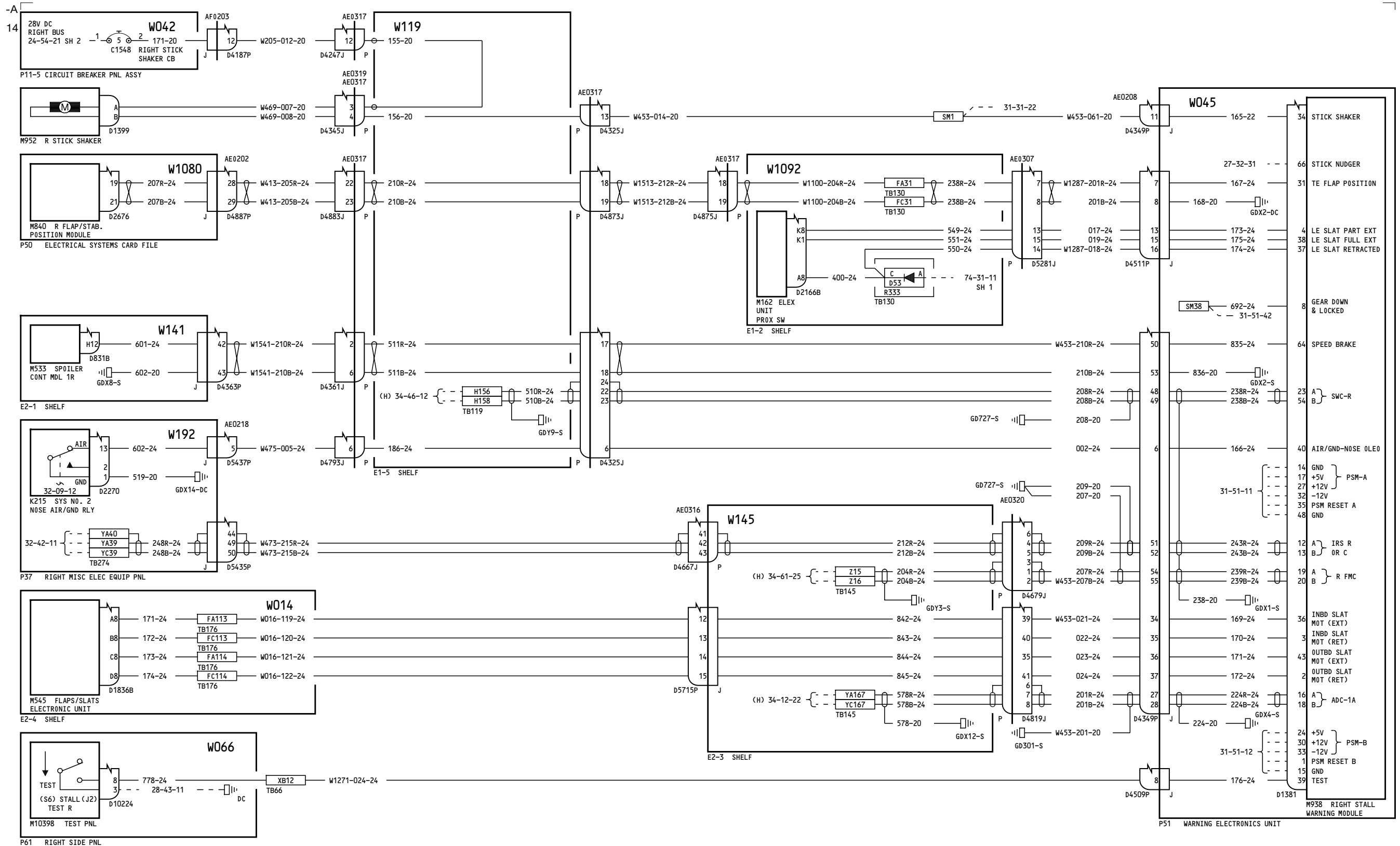

**WEU STALL WARNING-  
RIGHT**

**27-32-21**

D280T132

**27-32-21**

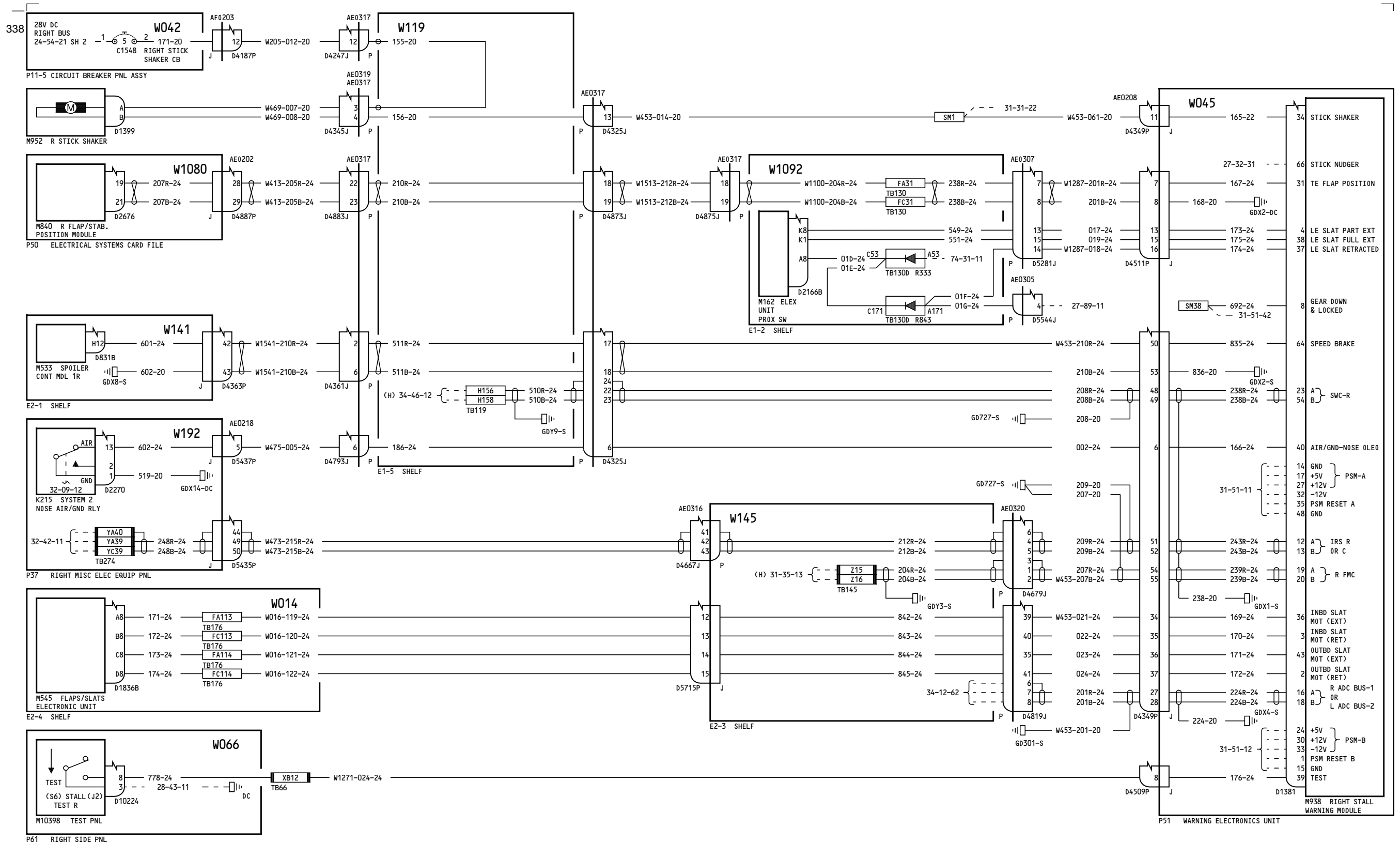

151

WEU STALL WARNING-RIGHT

27-32-21

Page 4.1

Mar 14/2007

D280T132

Incorporates 27A0140 34A0332 R02

27-32-21

Page 4.1

Mar 14/2007

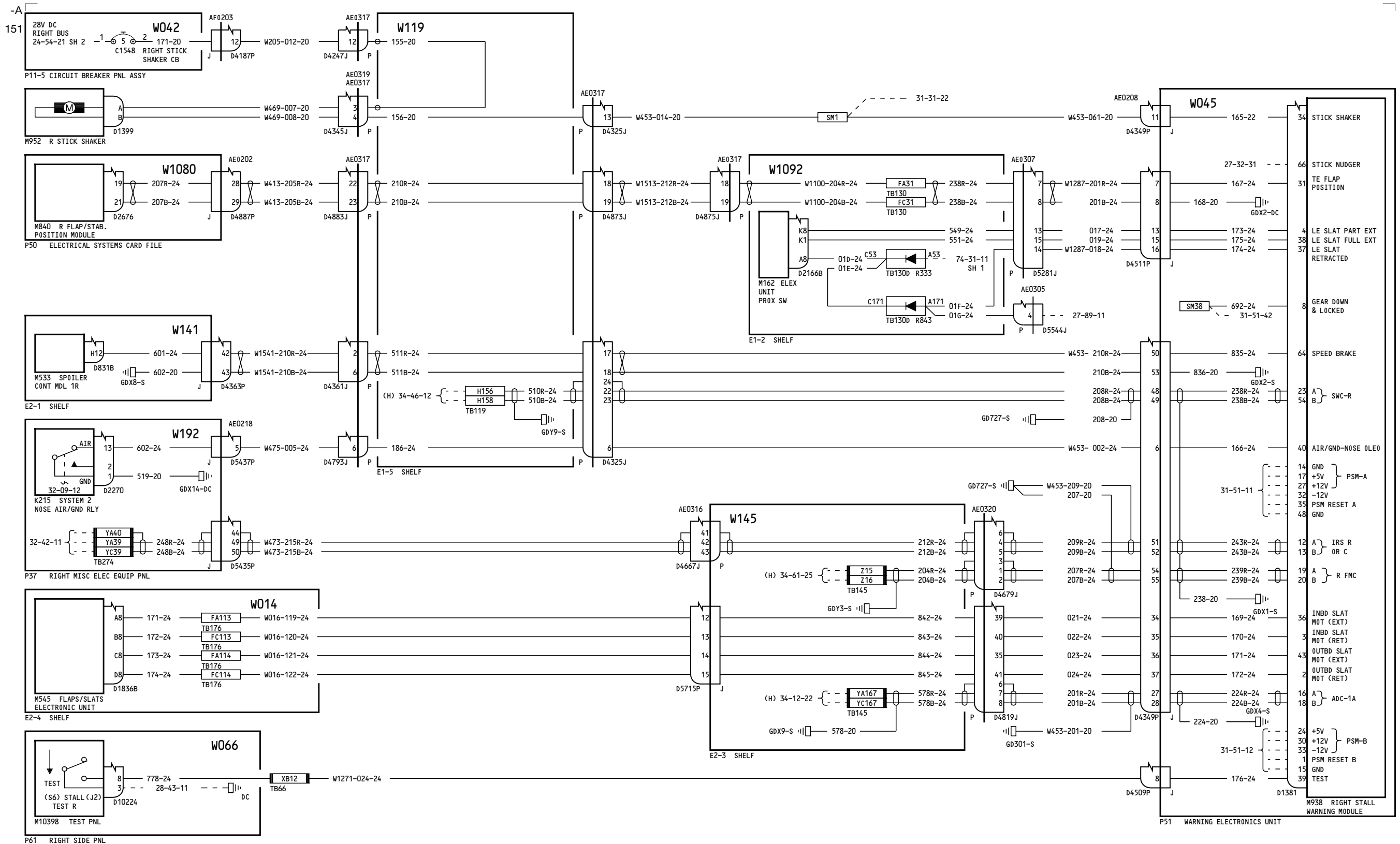

275-276

**WEU STALL WARNING-RIGHT**

D280T132

**27-32-21**

Page 5.1

Mar 14/2007

Incorporates  
 27A0140

**27-32-21**

Page 5.1

Mar 14/2007

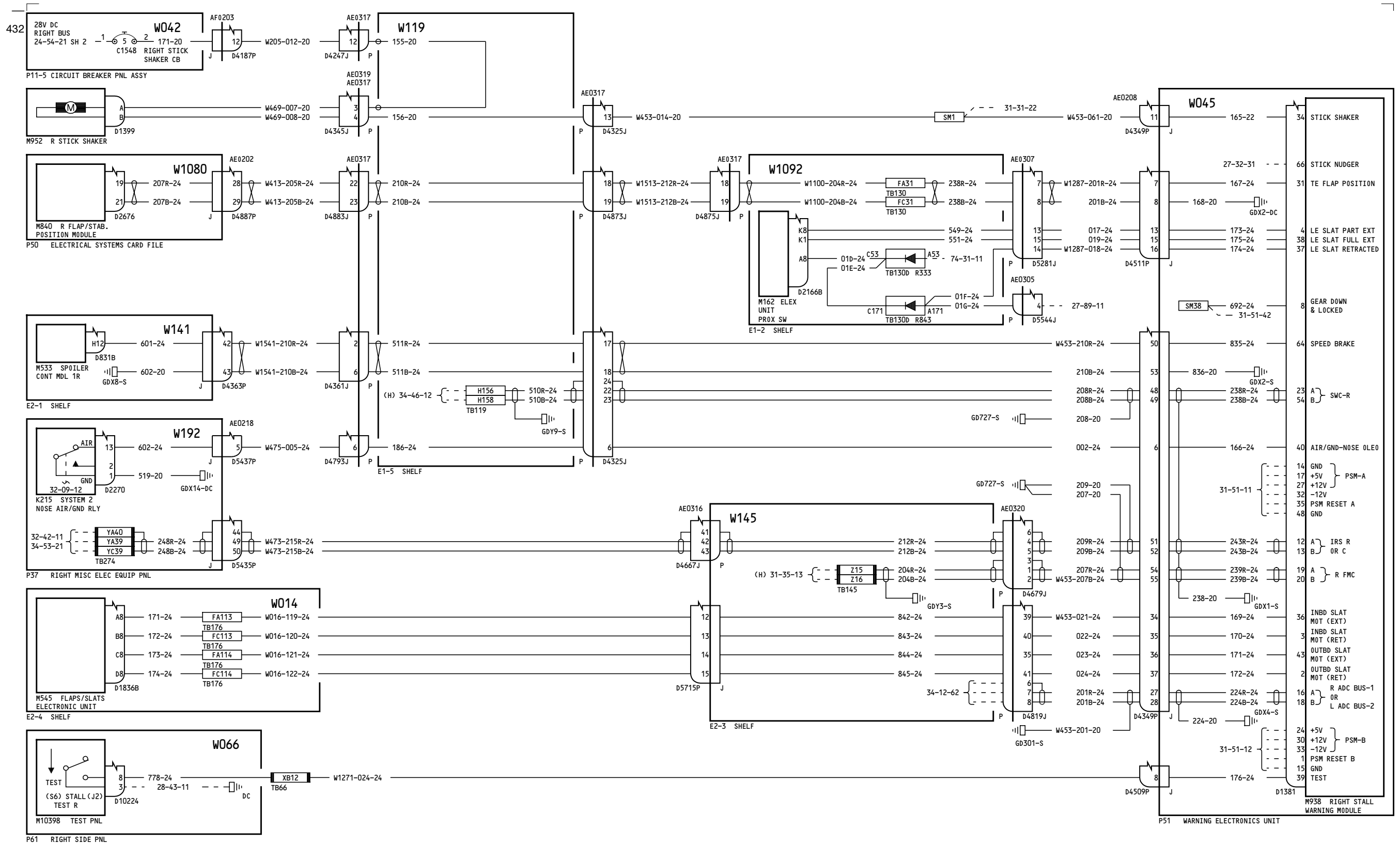

275-276

**WEU STALL WARNING-RIGHT**  
D280T132

Incorporates  
 27A0140  
 34A0332 R02  
 EOC EEB34-0360-02



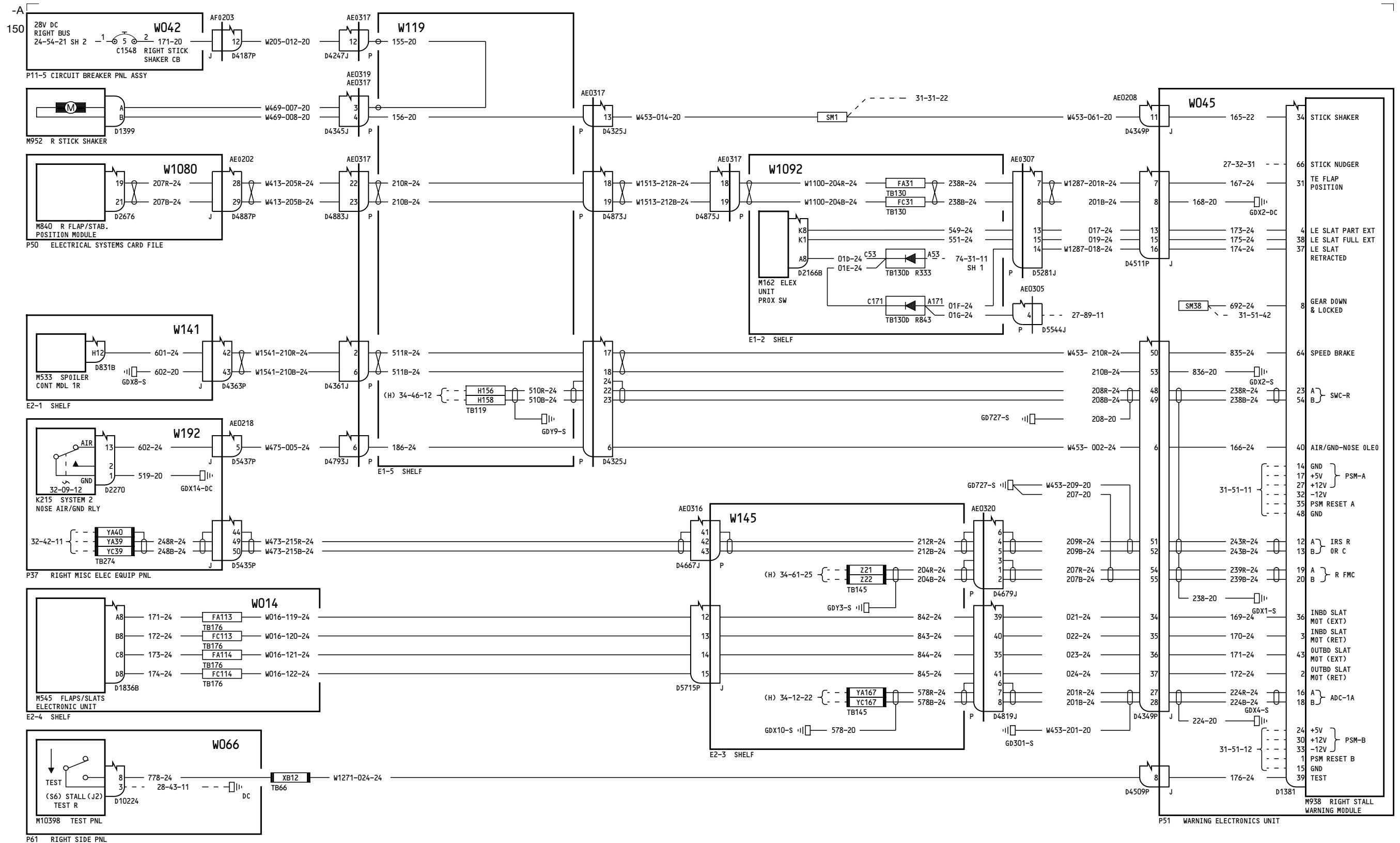

277-278

**WEU STALL WARNING-RIGHT**

D280T132

**27-32-21**

Page 6.1

Mar 14/2007

Incorporates  
27A0140

**27-32-21**

Page 6.1

Mar 14/2007

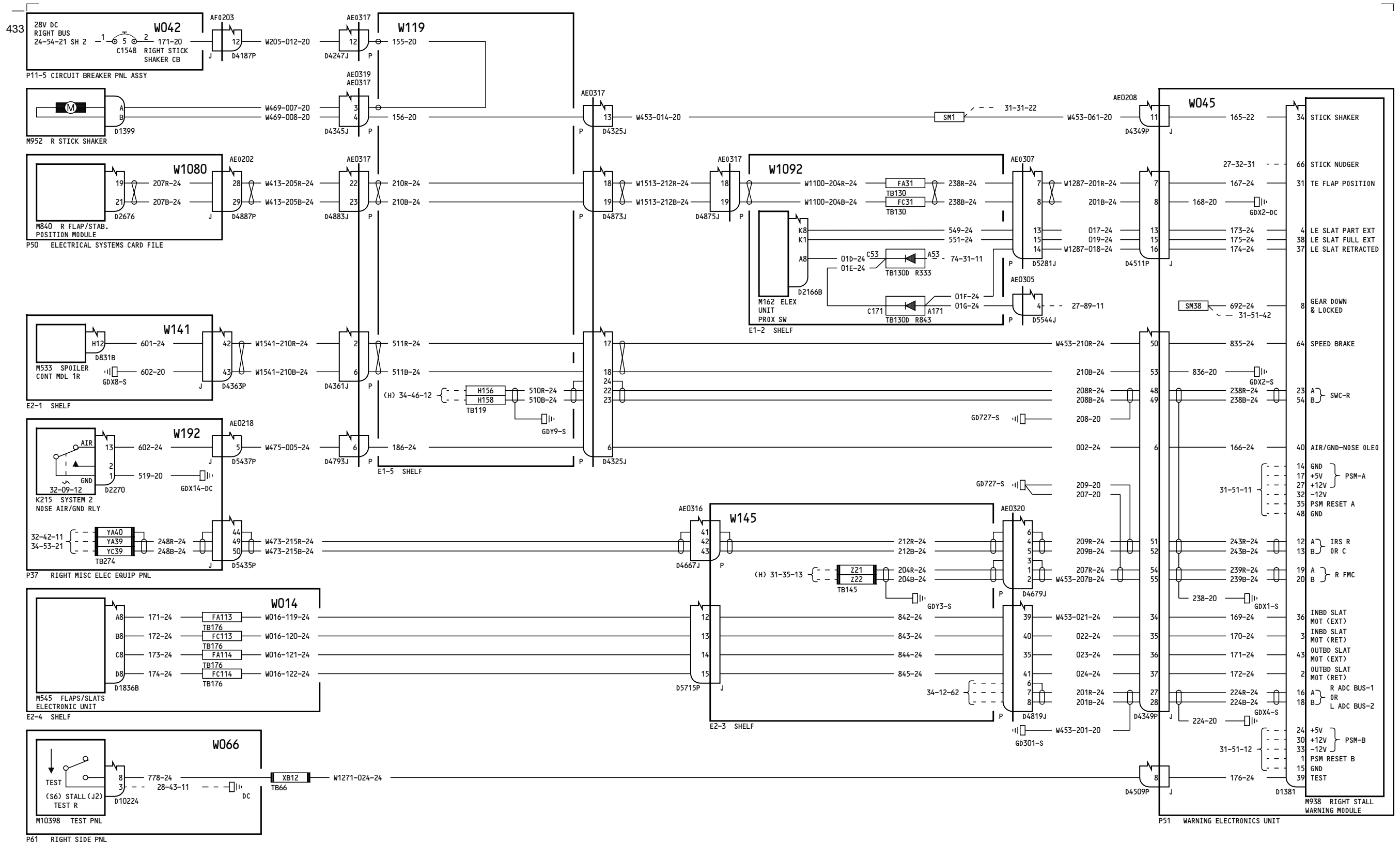

277-278

**WEU STALL WARNING-  
RIGHT**

D280T132

**27-32-21**

Page 6.2A

Mar 14/2007

Incorporates

- ▶ 27A0140
- ▶ 34A0332 R02
- ▶ EOC EEB34-0360-02

**27-32-21**

Page 6.2A

Mar 14/2007

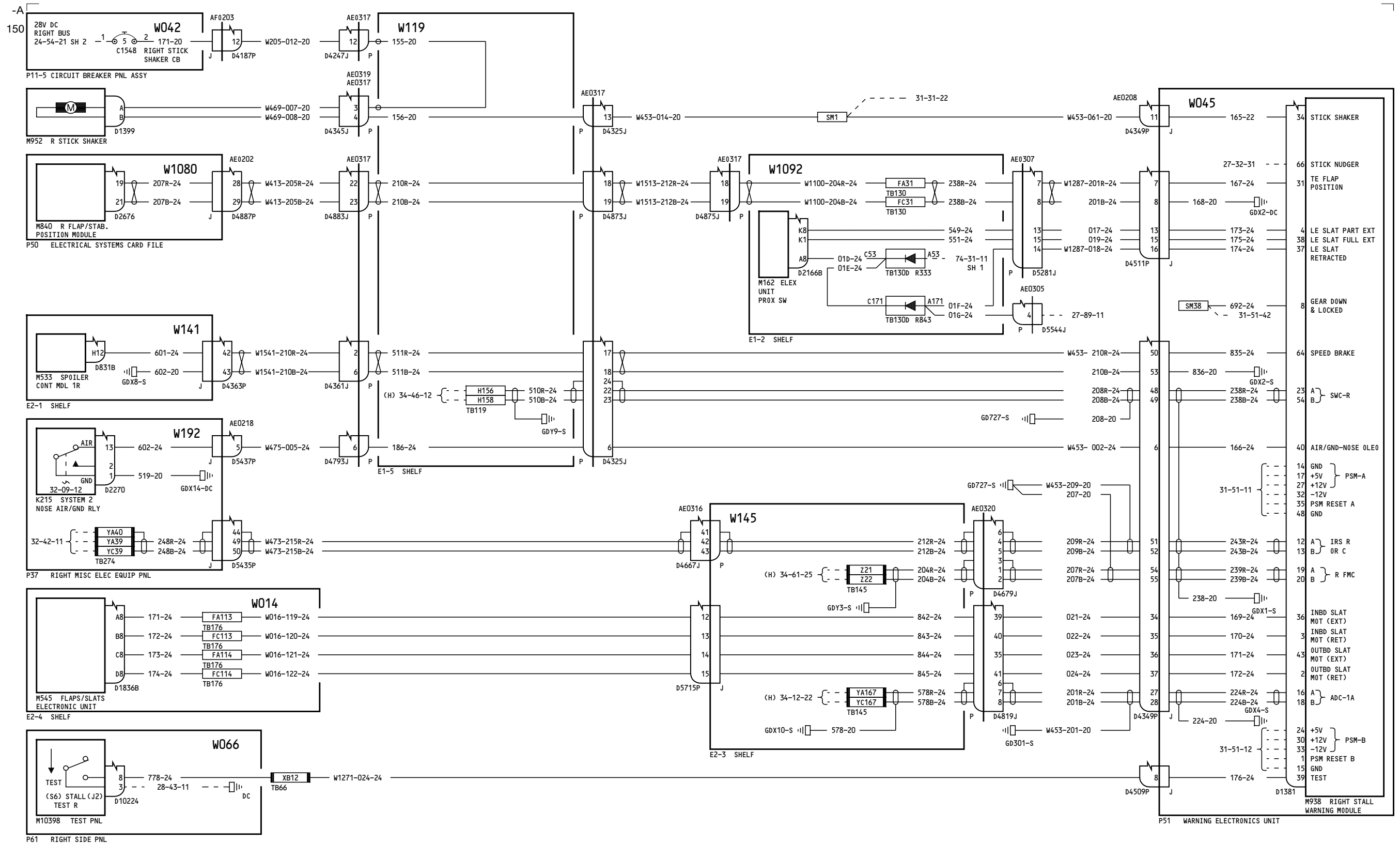

280

**WEU STALL WARNING-  
RIGHT**

D280T132

**27-32-21**

Page 7.1

Mar 14/2007

Incorporates  
27A0140 R01

**27-32-21**

Page 7.1

Mar 14/2007

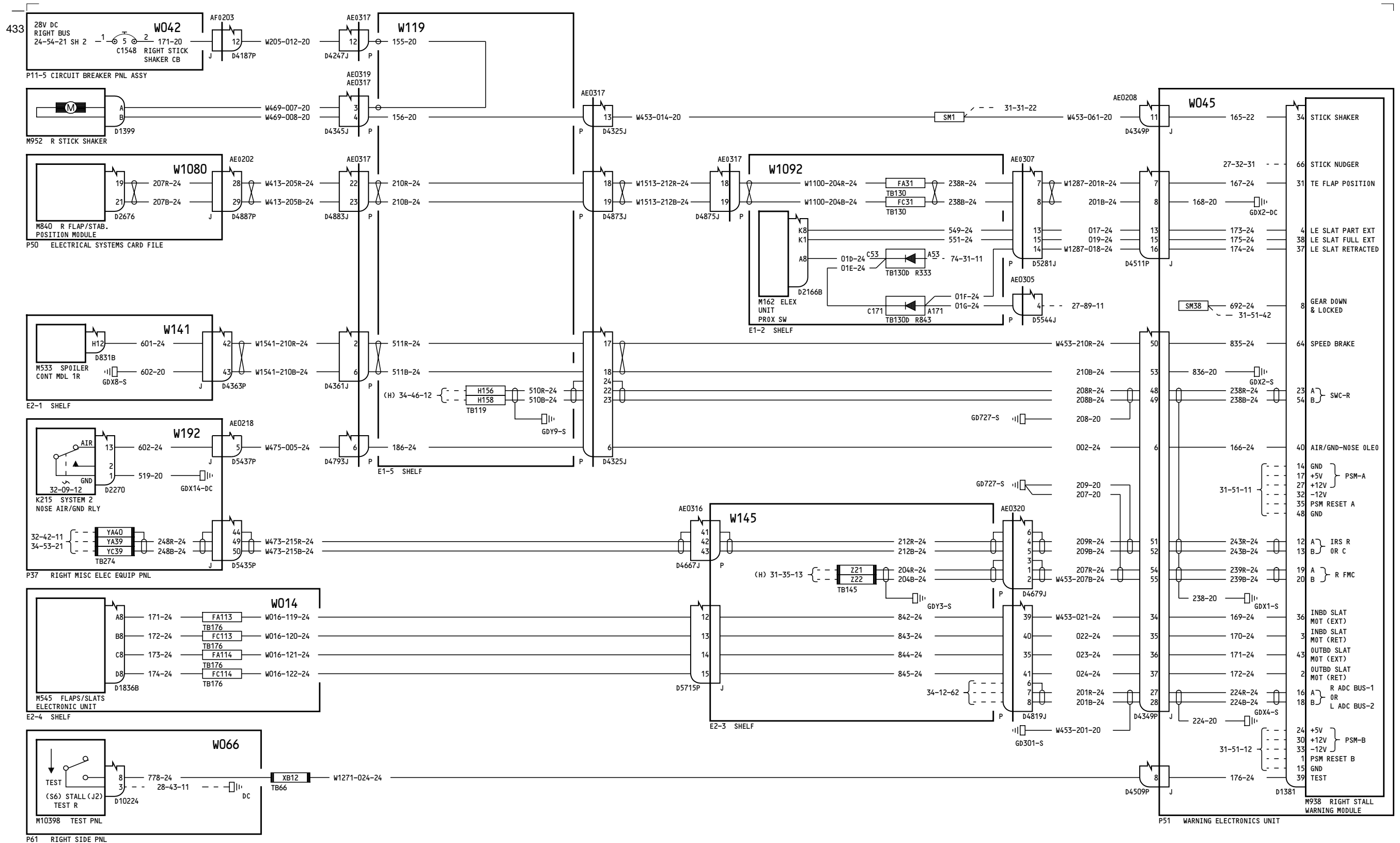

280

**WEU STALL WARNING-RIGHT**  
D280T132

**27-32-21**  
Page 7.2A  
Mar 14/2007

Incorporates  
 27A0140 R01  
 34A0332 R02  
 EOC EEB34-0360-02

**27-32-21**  
Page 7.2A  
Mar 14/2007

7

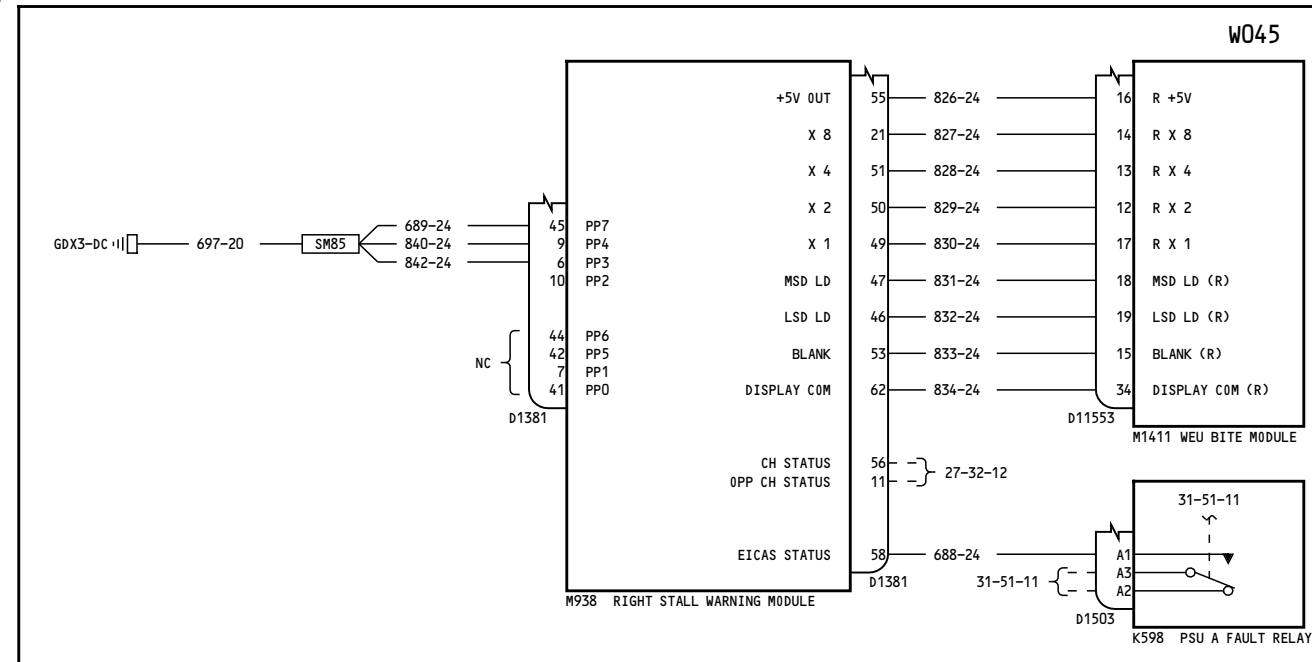

P51 WARNING ELECTRONICS UNIT

050-099

**WEU STALL WARNING  
BITE & STATUS-  
RIGHT**

**27-32-22**

Page 1

D280T132

Jan 21/2005

**27-32-22**

Page 1

Jan 21/2005

8

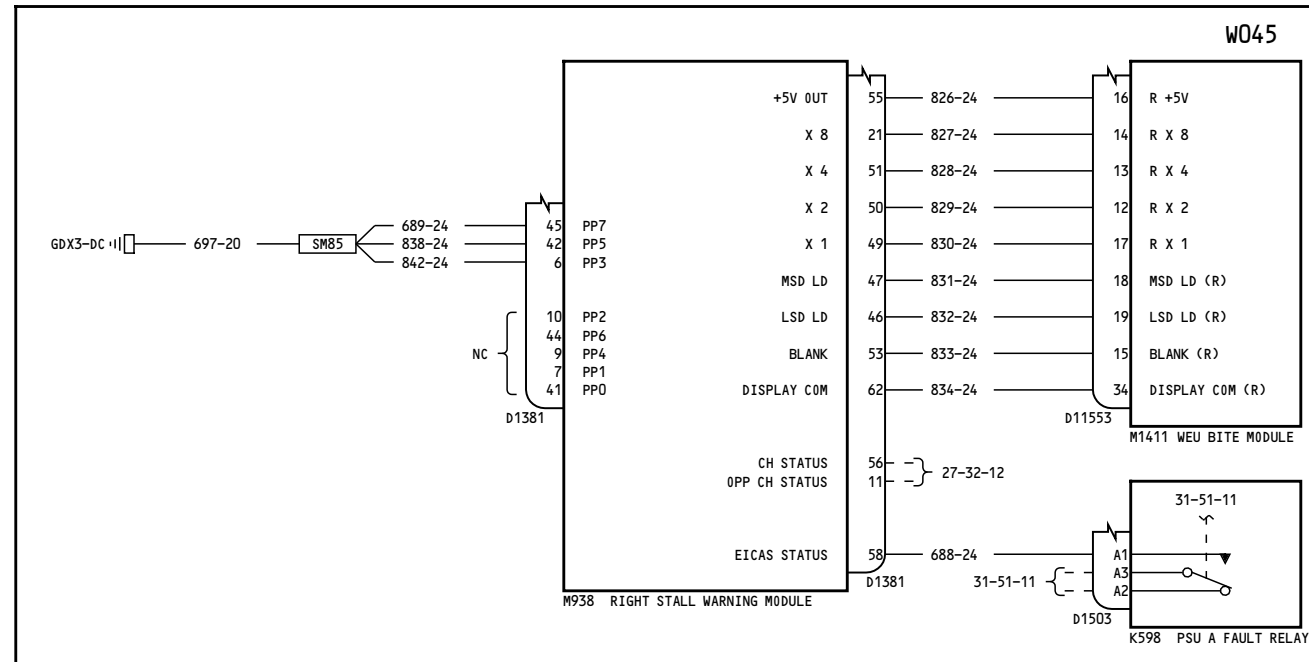

P51 WARNING ELECTRONICS UNIT

150-199, 275-299

**WEU STALL WARNING  
BITE & STATUS-  
RIGHT**

**27-32-22**

Page 2

D280T132

Jan 21/2005

**27-32-22**

Page 2

Jan 21/2005

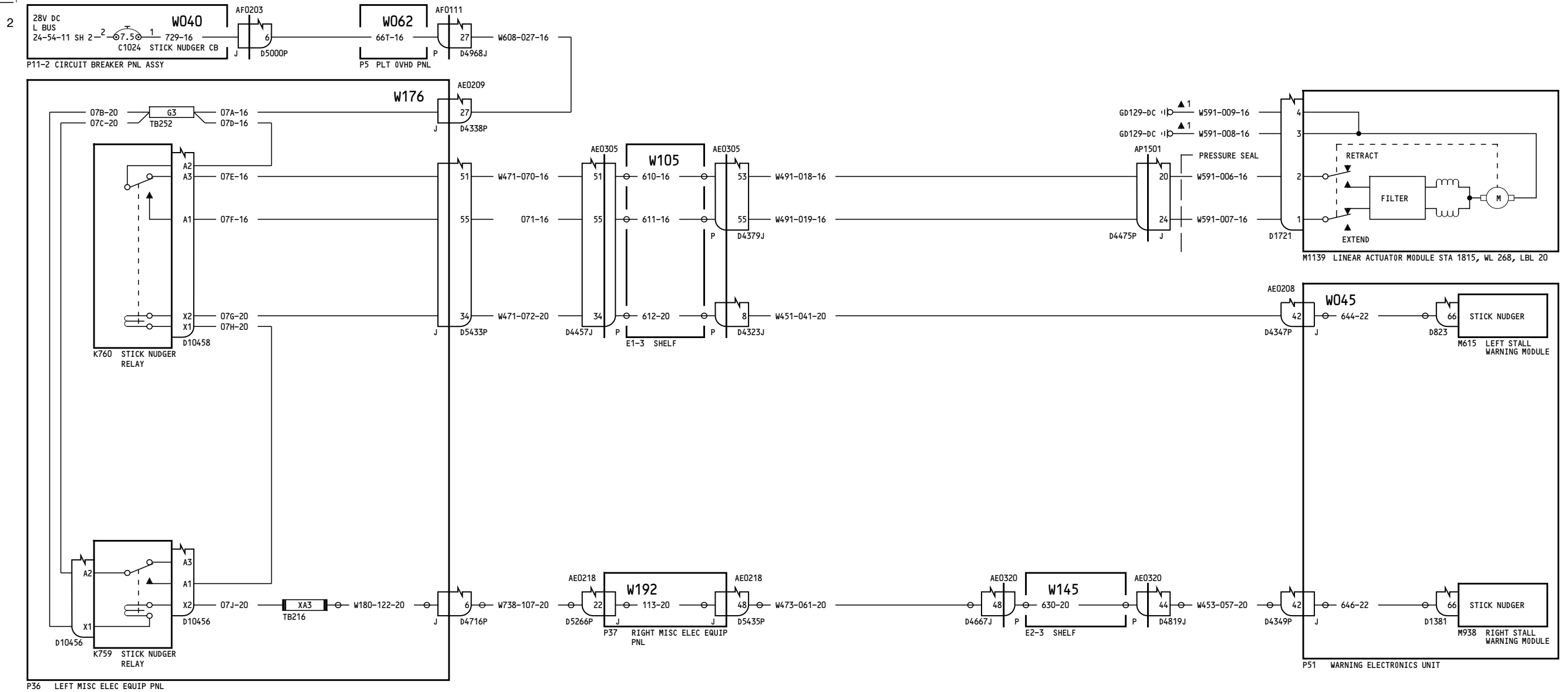

050-099, 150-199, 275-278

STICK NUDGER

27-32-31

Page 1

D280T132

Jan 21/2005

27-32-31

Page 1

Jan 21/2005

33

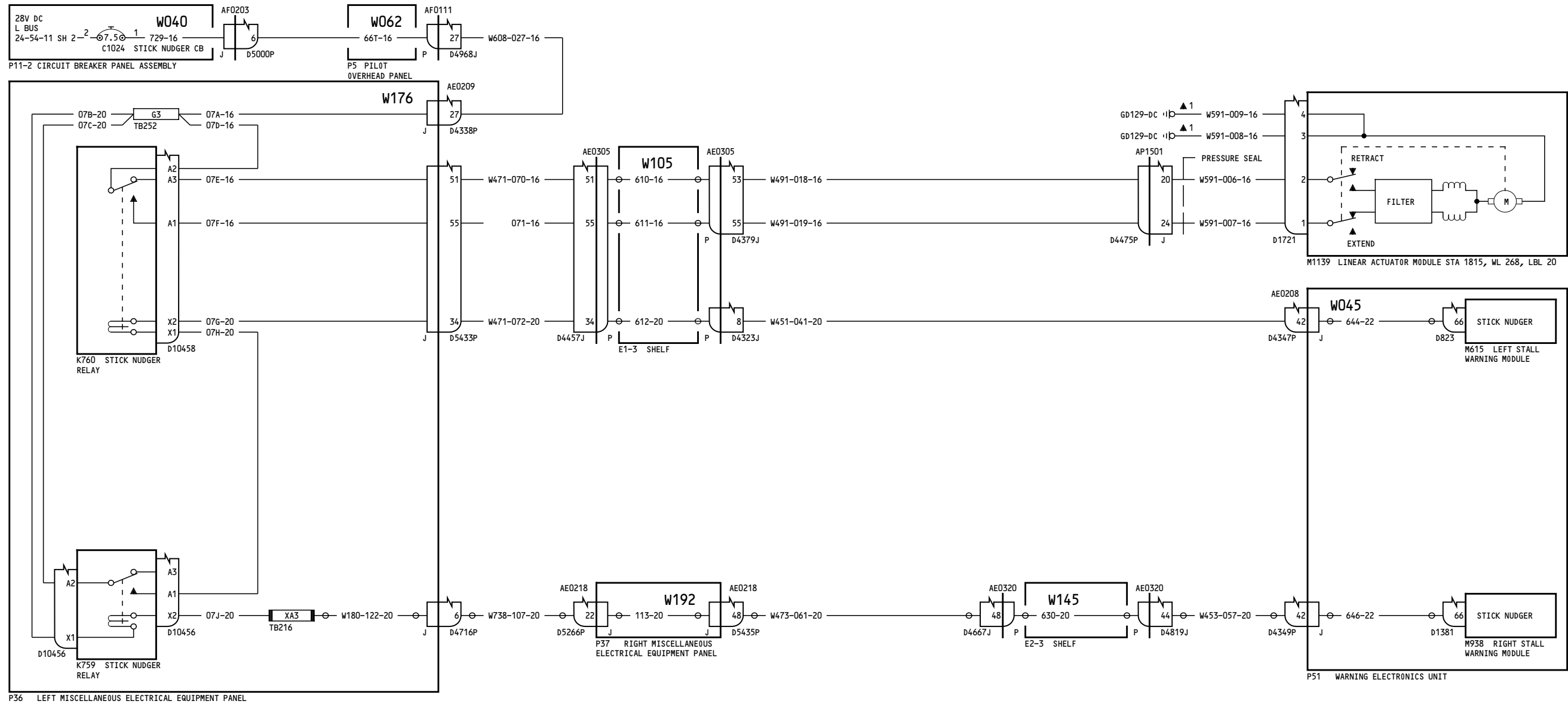

280-299

**STICK NUDGER**

**27-32-31**

Page 2

D280T132

Jan 21/2005

**27-32-31**

Page 2

Jan 21/2005



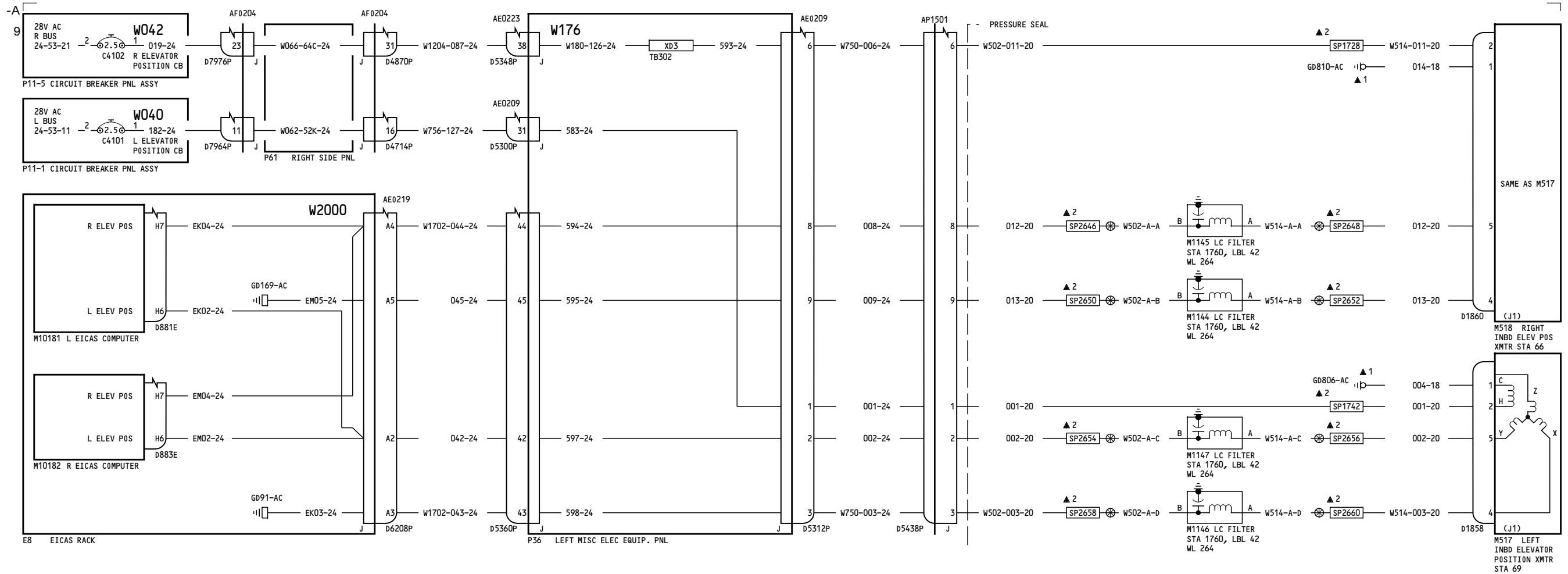

050-099

**ELEVATOR POSITION INDICATION**

**27-38-11**

Page 1

D280T132

Jan 21/2005

**27-38-11**

Page 1

Jan 21/2005

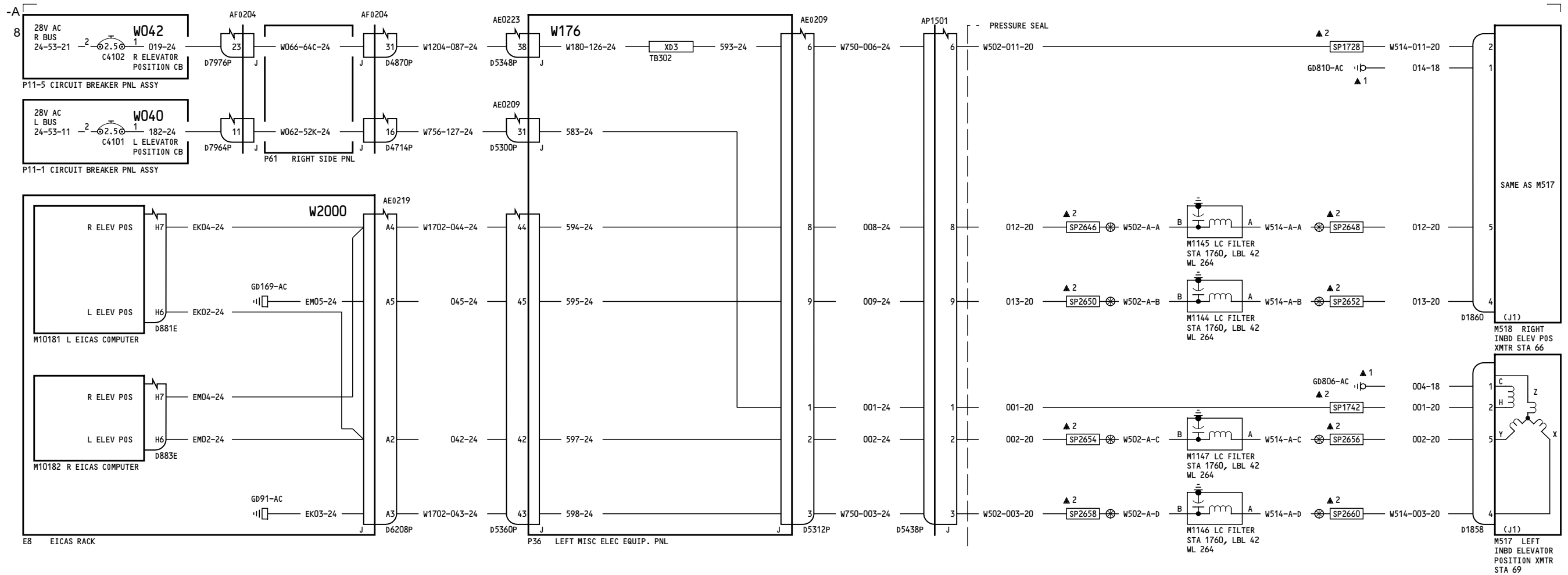

150-154, 162-165, 275-276

**ELEVATOR POSITION INDICATION**

**27-38-11**

Page 2

D280T132

Jan 21/2005

**27-38-11**

Page 2

Jan 21/2005

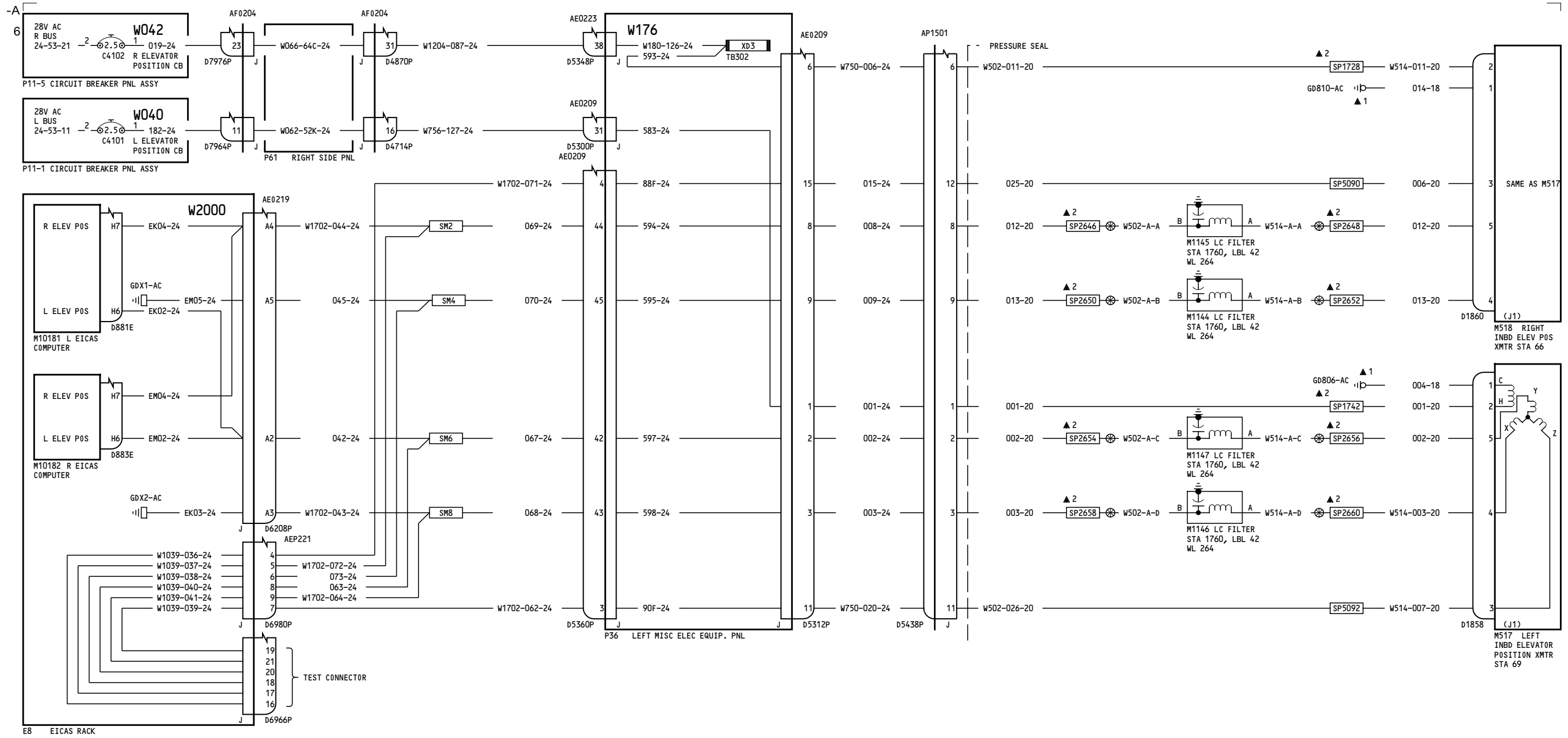

155, 157, 167-199, 277-299

**ELEVATOR POSITION INDICATION**

**27-38-11**

Page 3

D280T132

Jan 21/2005

**27-38-11**

Page 3

Jan 21/2005

**27-38-11**

Page 3

Jan 21/2005

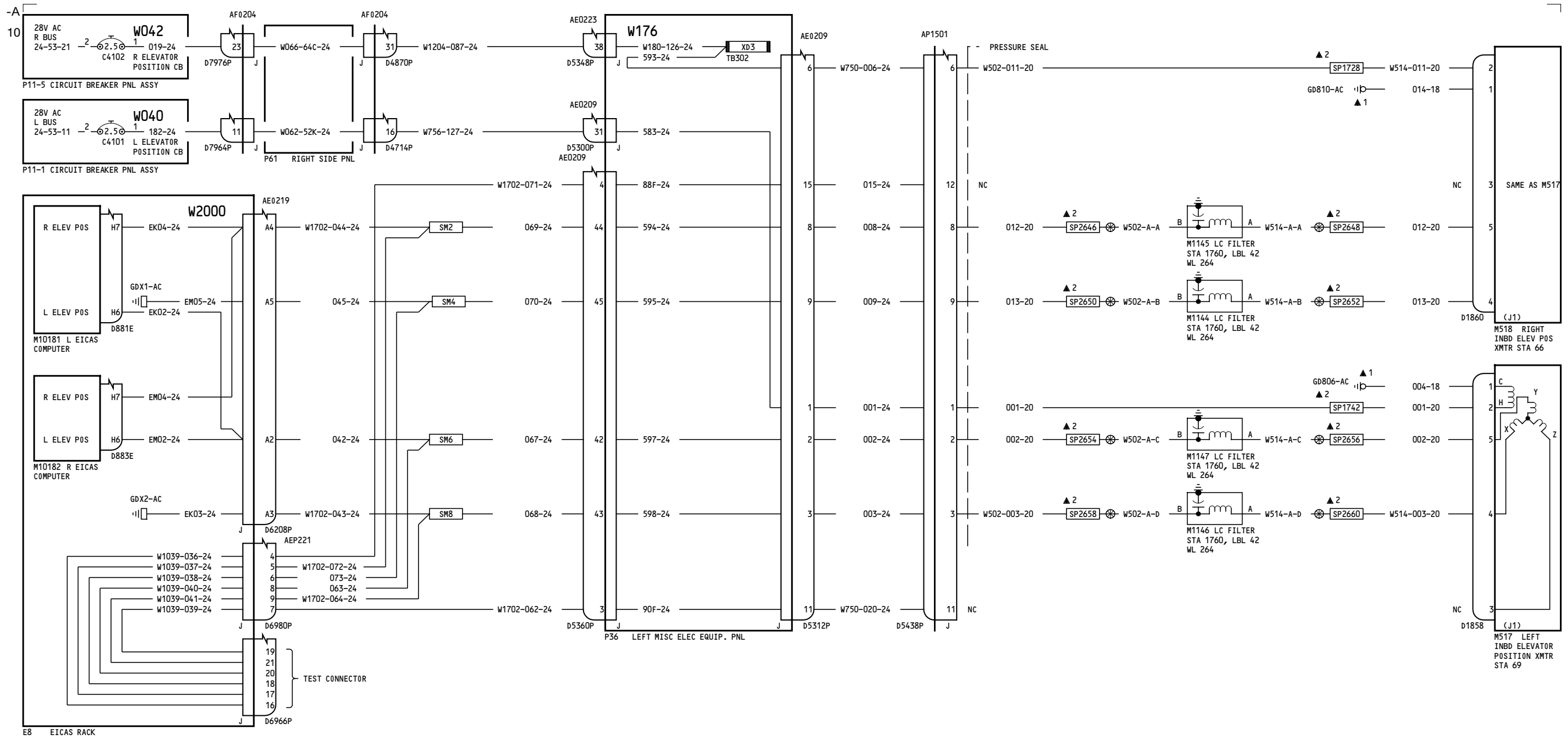

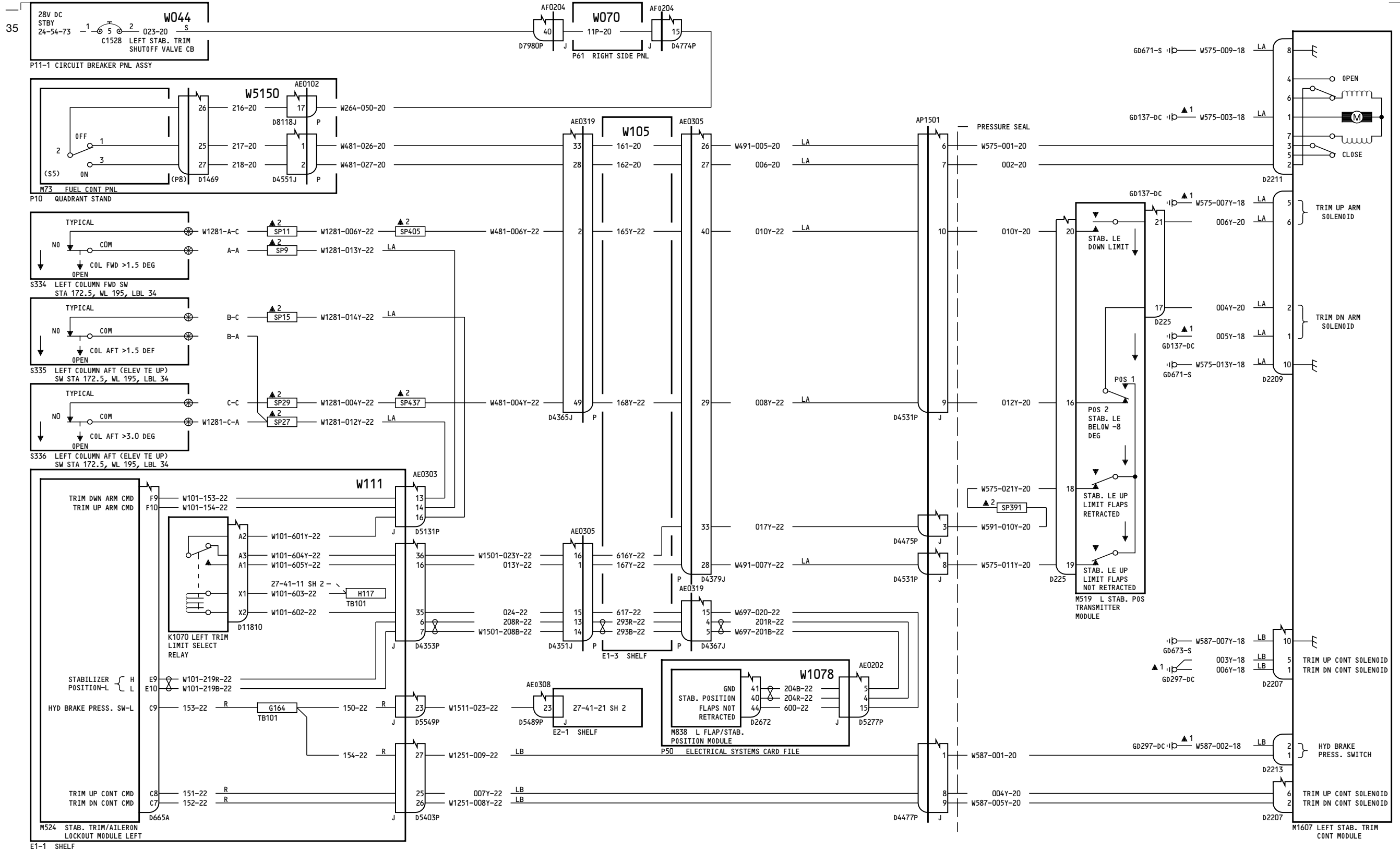

050-099

**MANUAL STABILIZER TRIM-LEFT**

D280T132

**27-41-11**

Page 1  
Sheet 1  
Jan 21/2005

**27-41-11**

Page 1  
Sheet 1  
Jan 21/2005

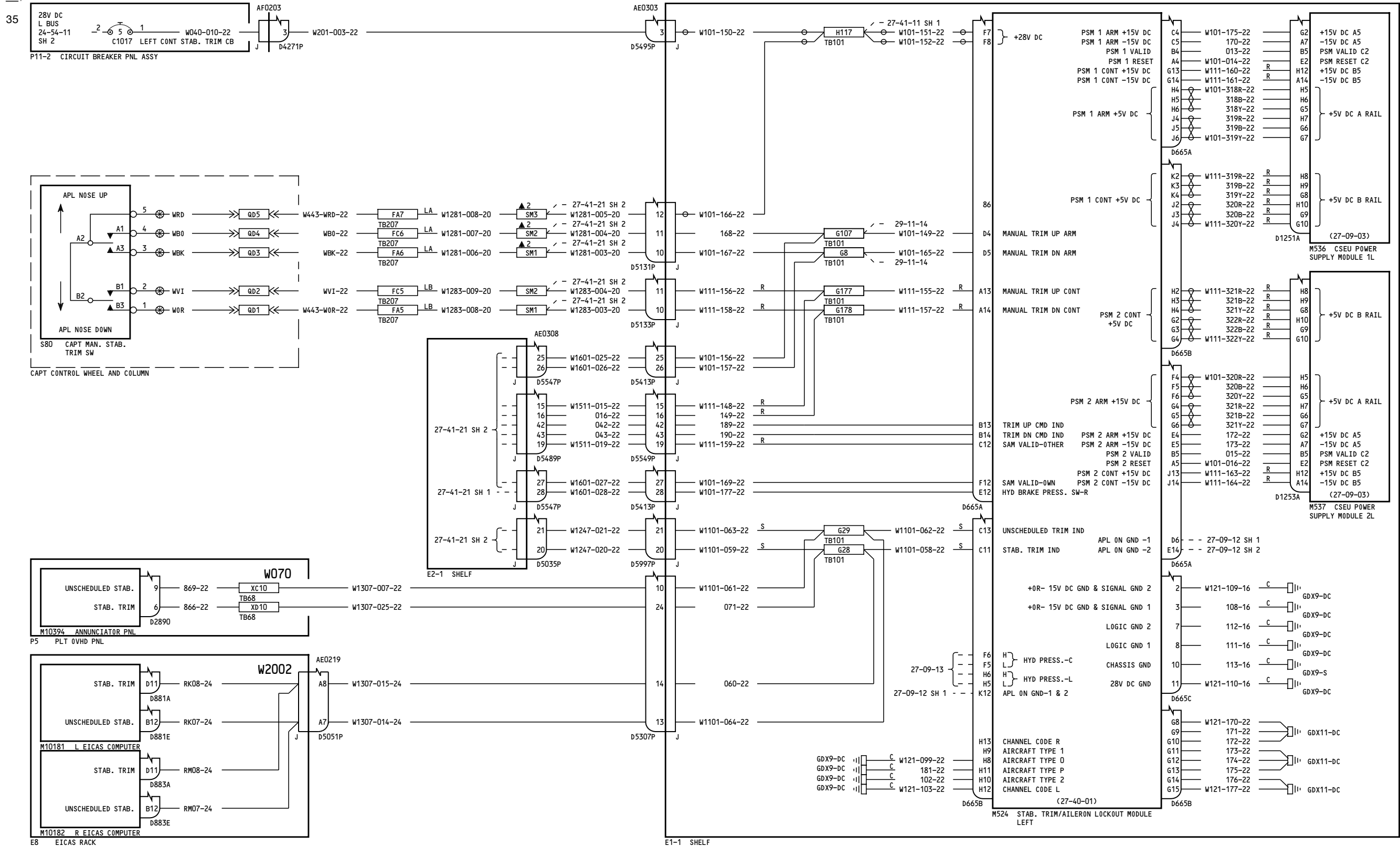

050-099  
**MANUAL STABILIZER TRIM-LEFT**  
 D280T132

**27-41-11**  
 Page 1  
 Sheet 2  
 Jan 21/2005

**27-41-11**  
 Page 1  
 Sheet 2  
 Jan 21/2005

**27-41-11**  
 Page 1  
 Sheet 2  
 Jan 21/2005

**27-41-11**  
 Page 1  
 Sheet 2  
 Jan 21/2005

BOEING PROPRIETARY - Copyright © - Unpublished Work - See title page for details.

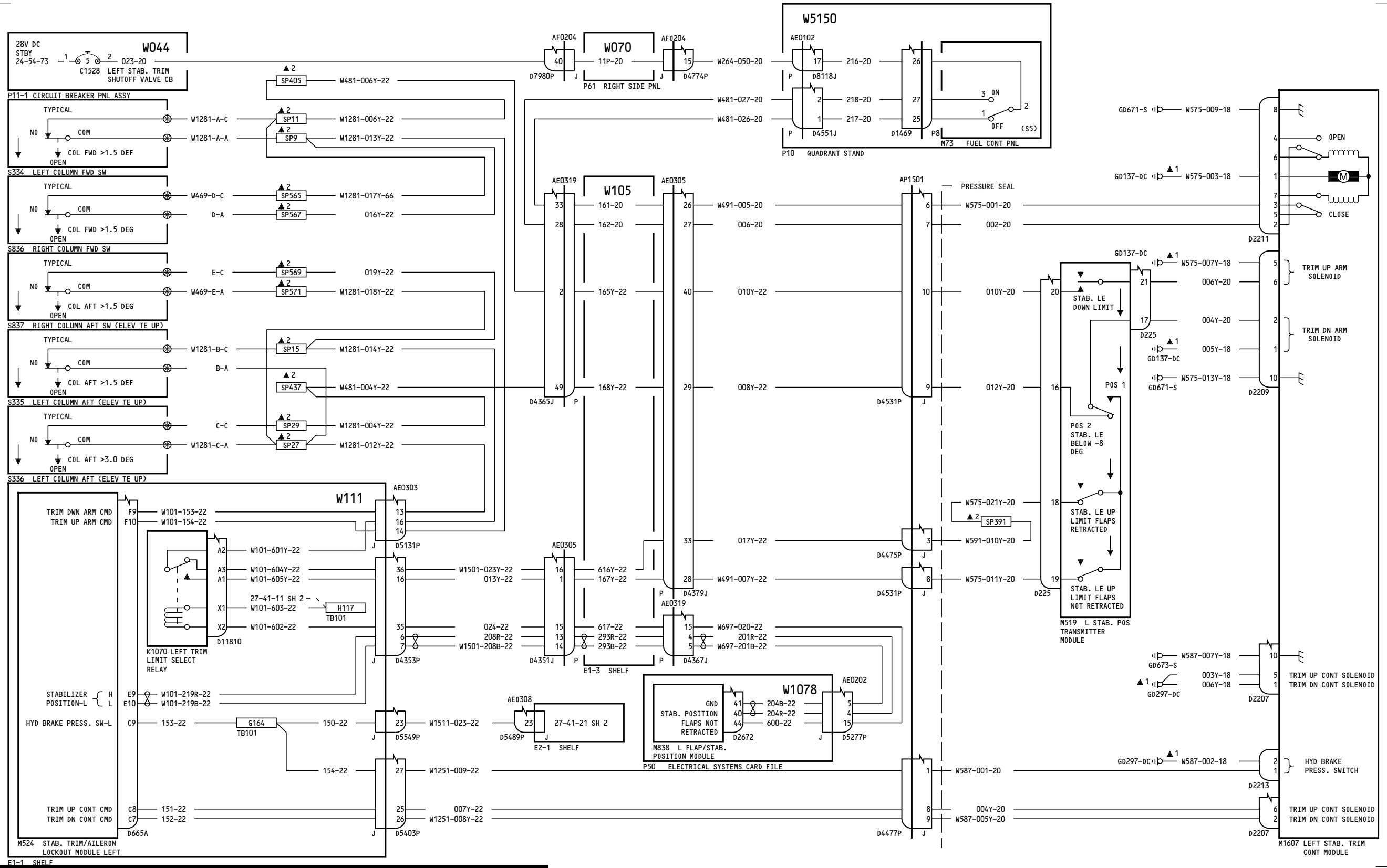

050-051

**MANUAL STABILIZER TRIM-LEFT**

**27-41-11**

Page 1.1  
Sheet 1  
Jan 21/2005

D280T132

**27-41-11**

Page 1.1  
Sheet 1  
Jan 21/2005

Incorporates  
27-0102 NSC03

**27-41-11**

Page 1.1  
Sheet 1  
Jan 21/2005

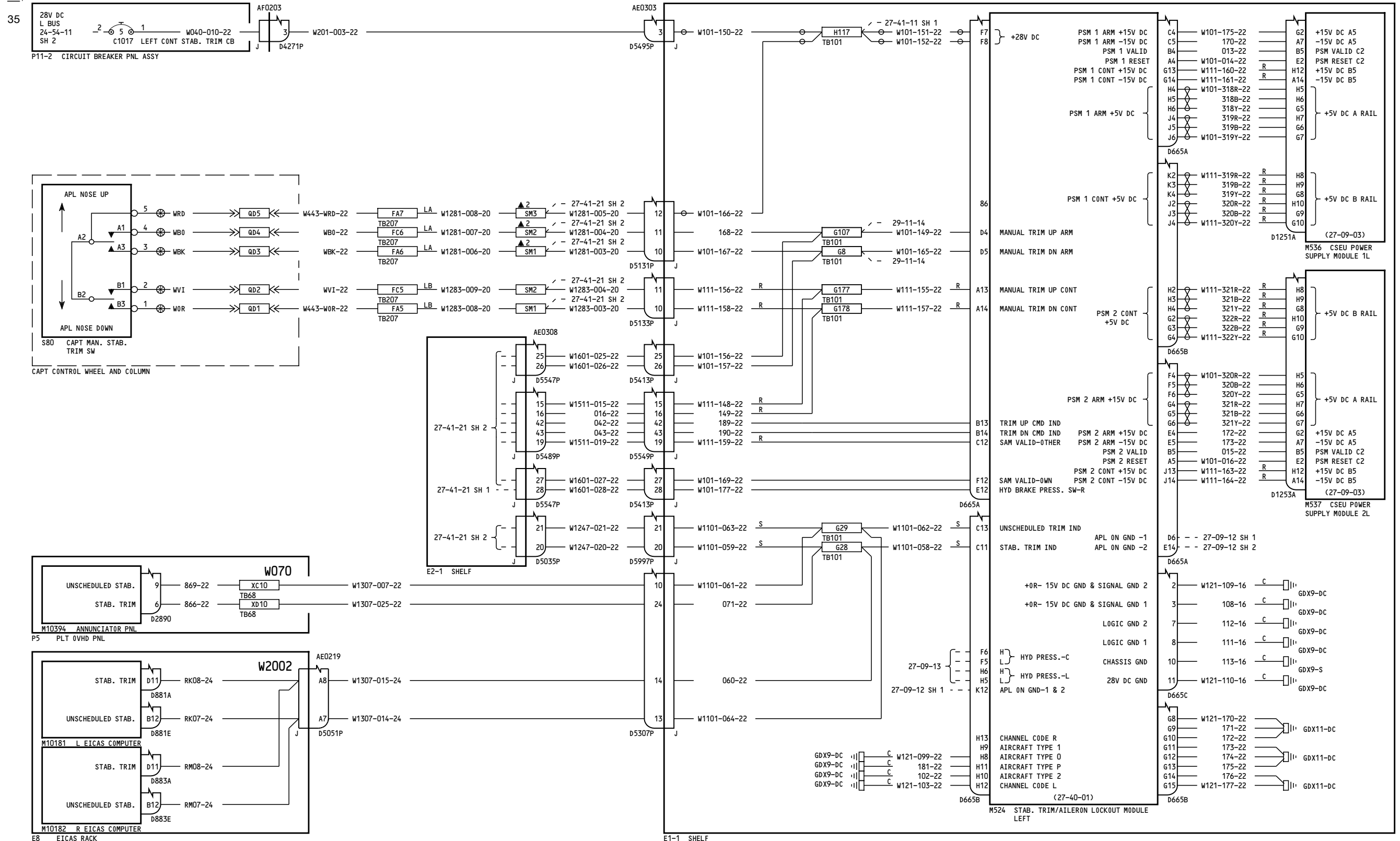



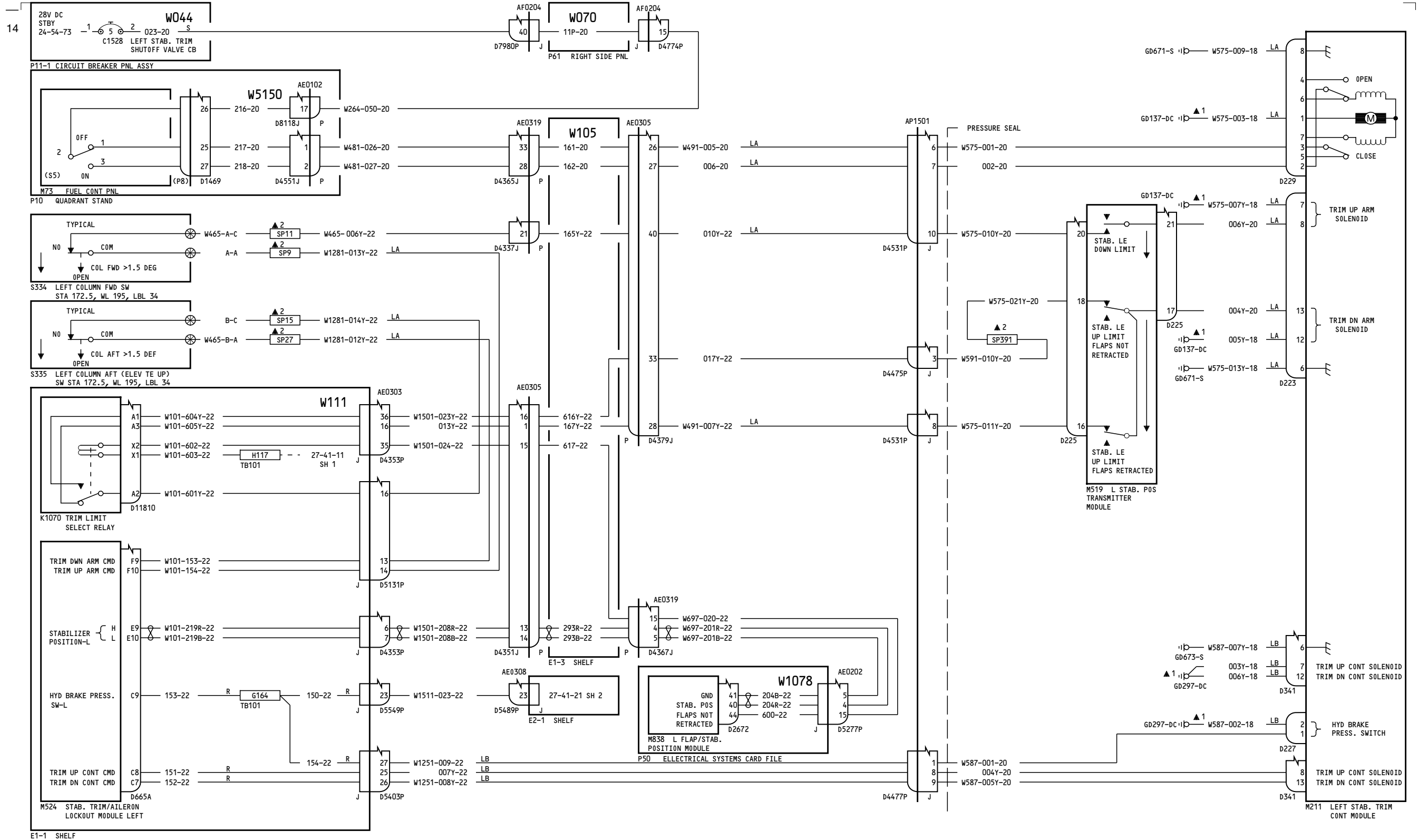

150-154

**MANUAL STABILIZER TRIM-LEFT**

D280T132

27-41-11

Page 2  
Sheet 1  
Jan 21/2005

27-41-11

Page 2  
Sheet 1  
Jan 21/2005

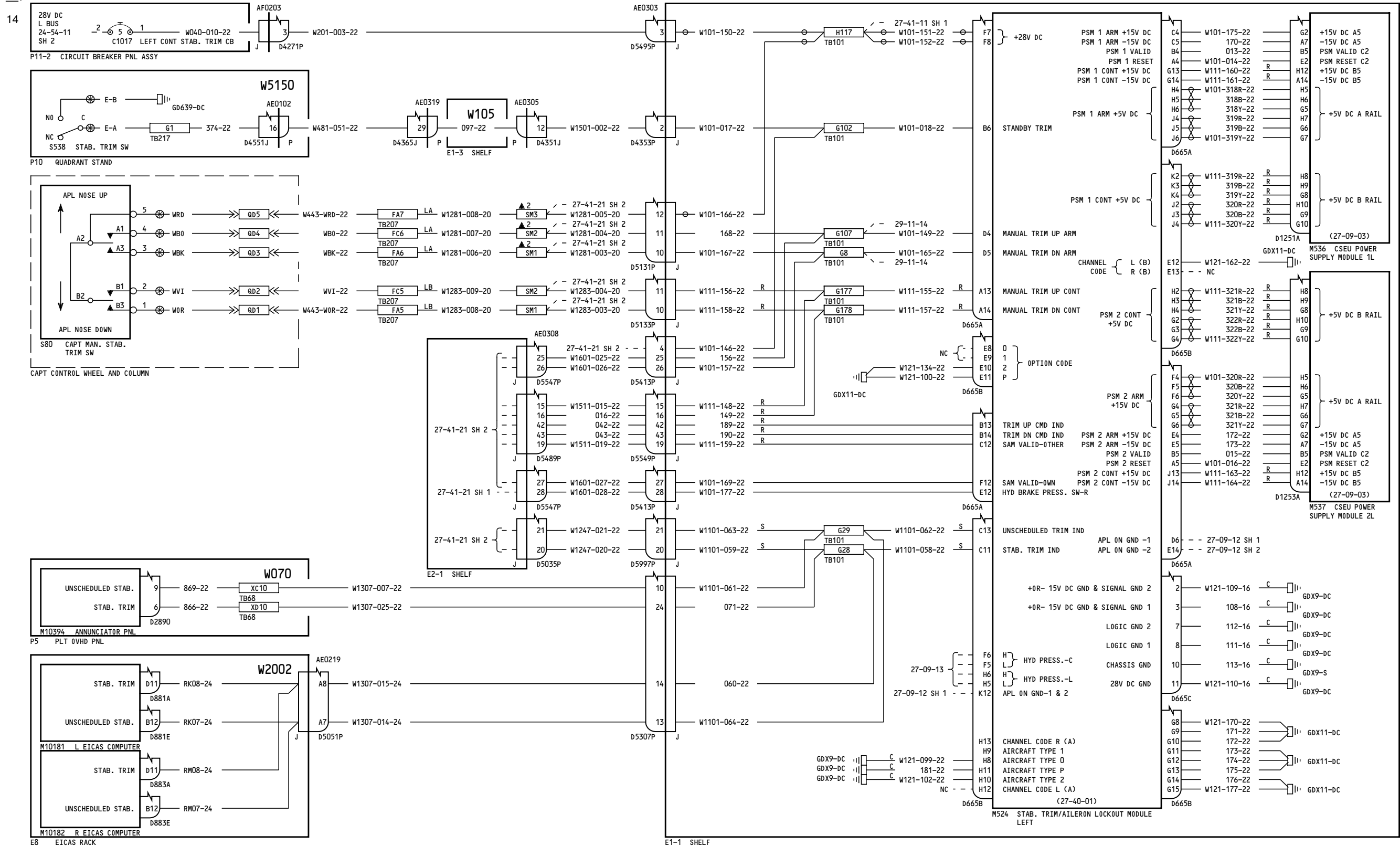

150-154

**MANUAL STABILIZER TRIM-LEFT**

D280T132

**27-41-11**

Page 2  
Sheet 2  
Jan 21/2005

**27-41-11**

Page 2  
Sheet 2  
Jan 21/2005

111

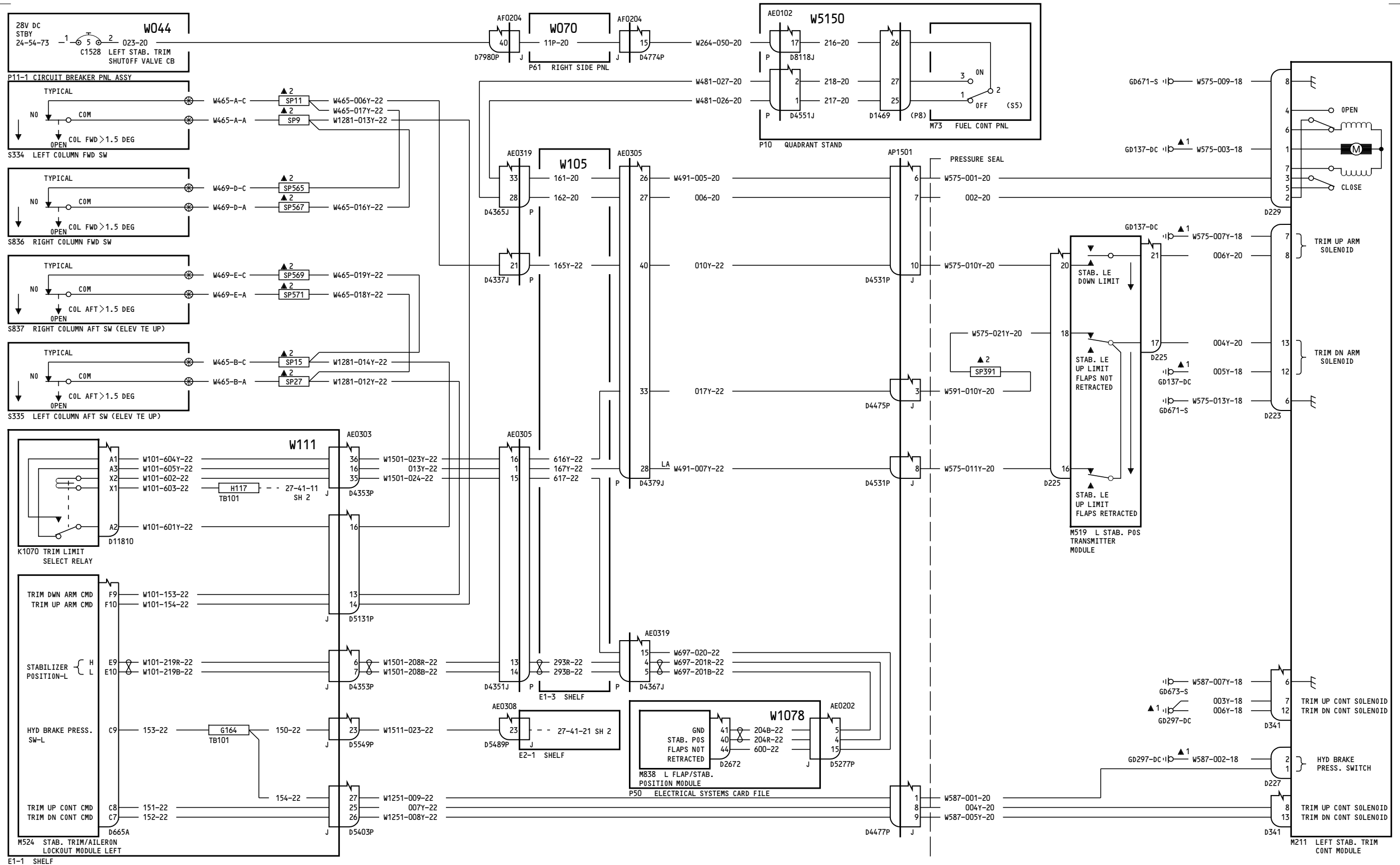

150-154

**MANUAL STABILIZER TRIM-LEFT**

D280T132

**27-41-11**

Page 2.1  
Sheet 1  
Jan 21/2005

Incorporates  
27-0102 NSC03

**27-41-11**

Page 2.1  
Sheet 1  
Jan 21/2005

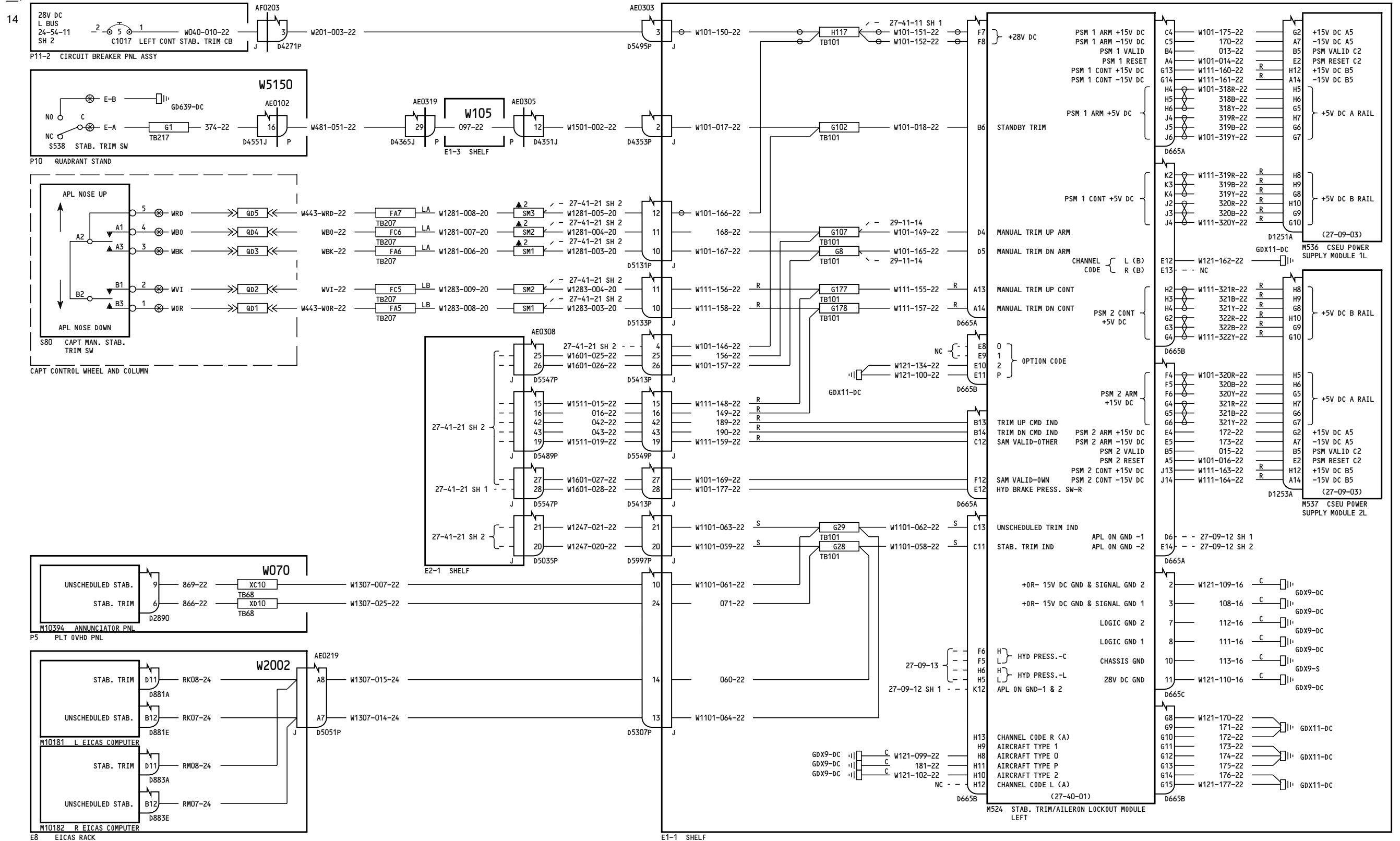

150-154

**MANUAL STABILIZER TRIM-LEFT**

D280T132

**27-41-11**

Page 2.1  
Sheet 2  
Jan 21/2005

**27-41-11**

Page 2.1  
Sheet 2  
Jan 21/2005

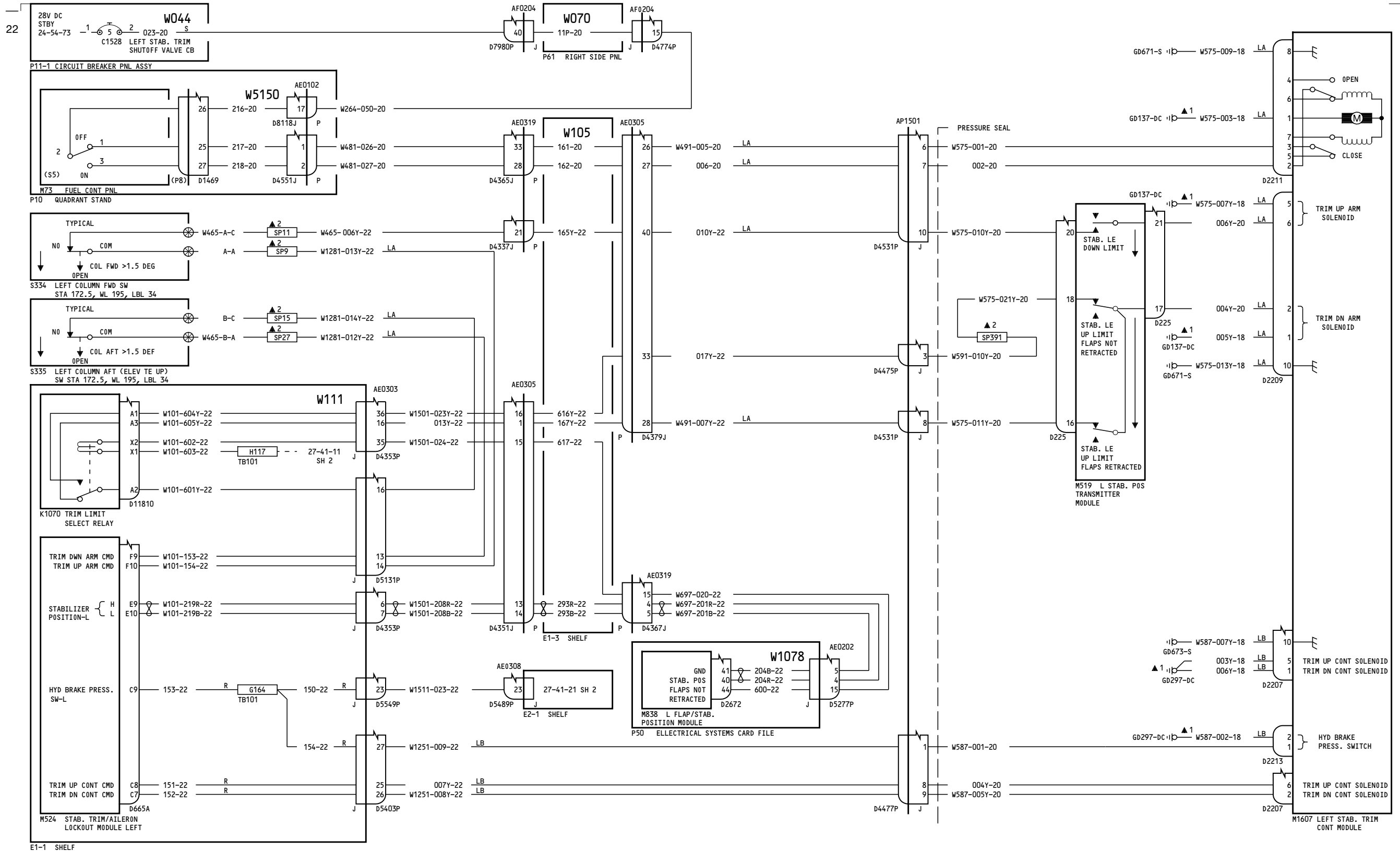

155-166

**MANUAL STABILIZER TRIM-LEFT**

D280T132

**27-41-11**

Page 3  
Sheet 1  
Jan 21/2005

**27-41-11**

Page 3  
Sheet 1  
Jan 21/2005

22

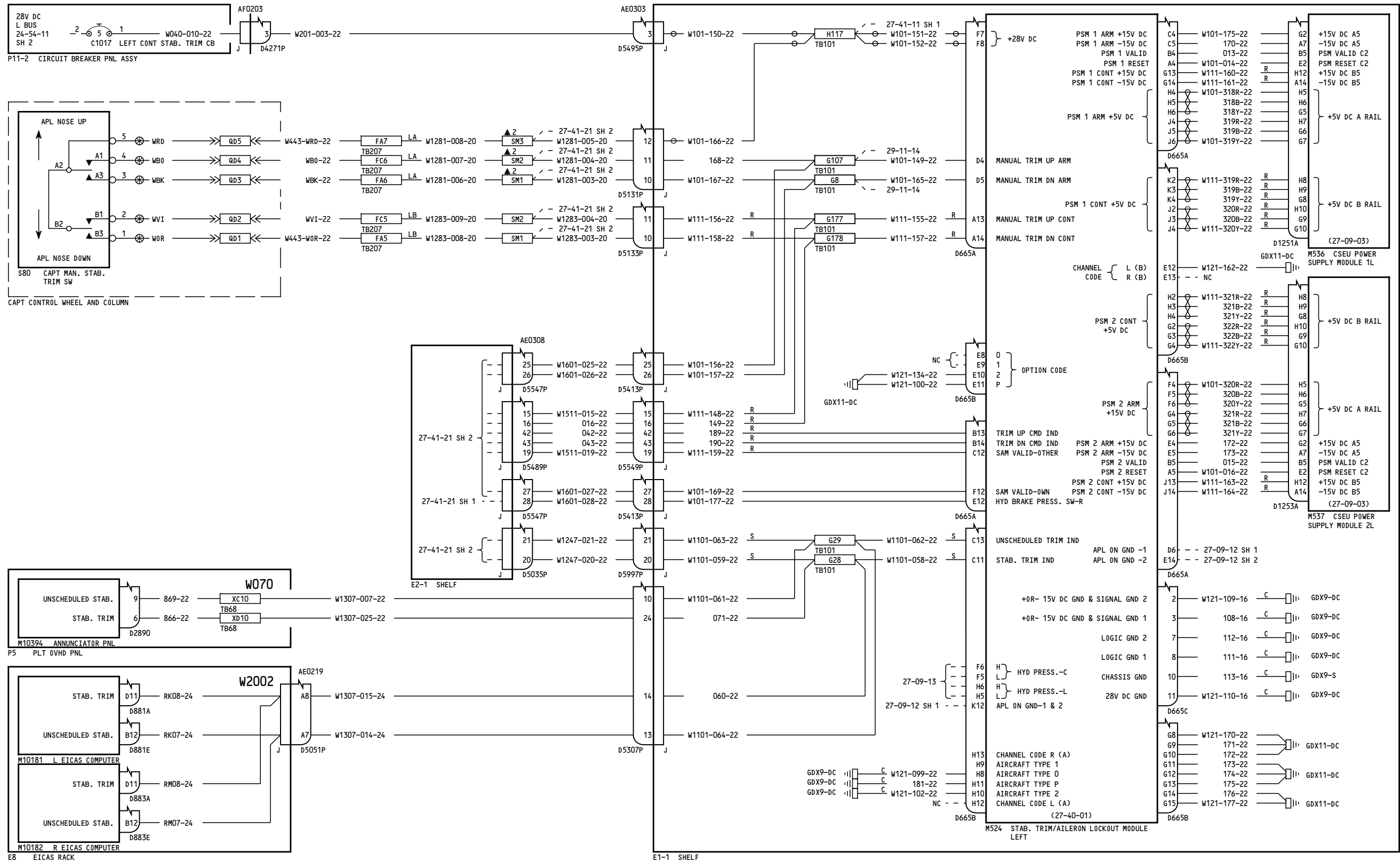

155-166

**MANUAL STABILIZER TRIM-LEFT**

**27-41-11**

Page 3  
Sheet 2  
Jan 21/2005

D280T132

**27-41-11**

Page 3  
Sheet 2  
Jan 21/2005

-A  
39

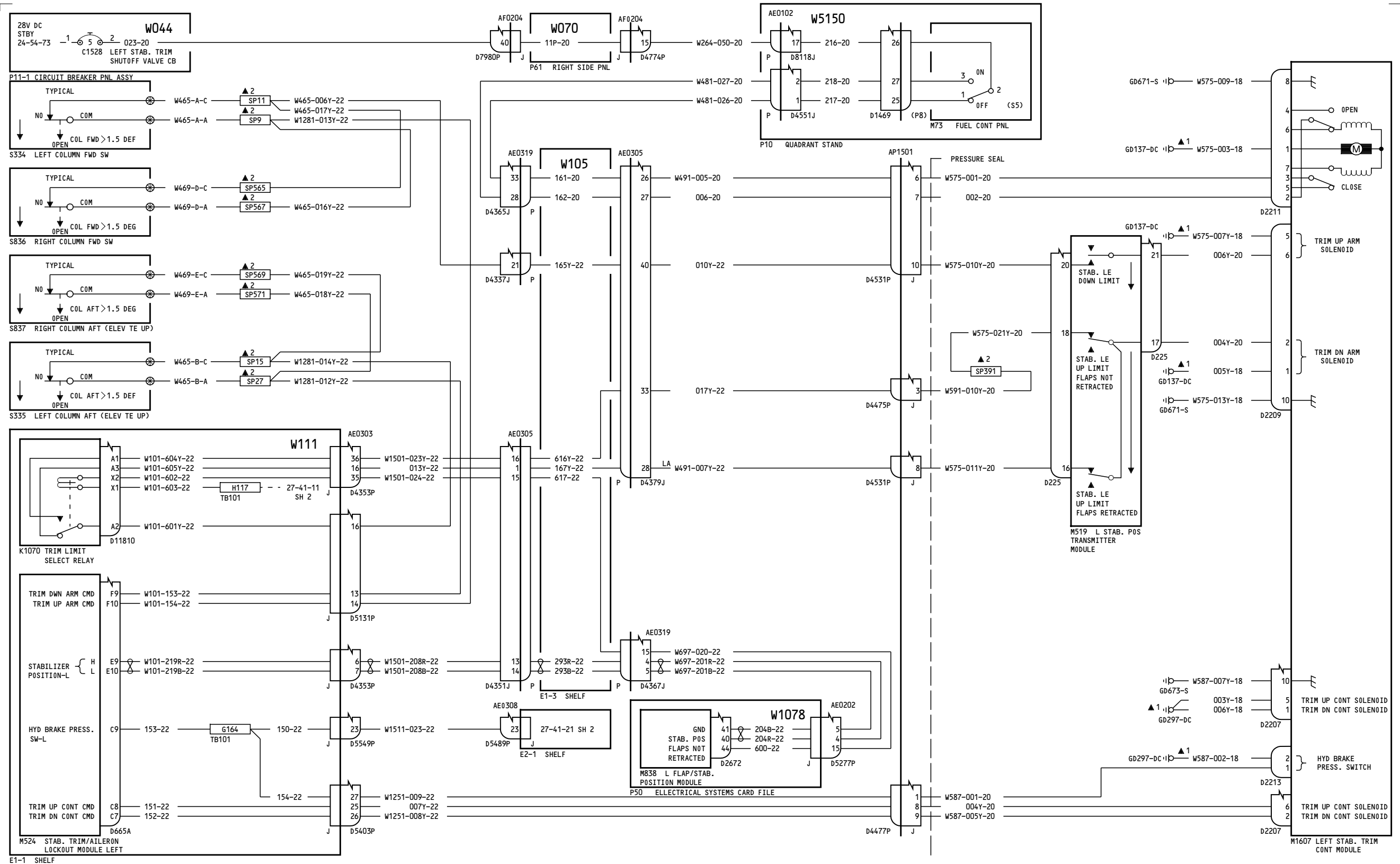

155-166

**MANUAL STABILIZER TRIM-LEFT**

D280T132

**27-41-11**

Page 3.1  
Sheet 1  
Jan 21/2005

Incorporates  
27-0102 NSC03

**27-41-11**

Page 3.1  
Sheet 1  
Jan 21/2005

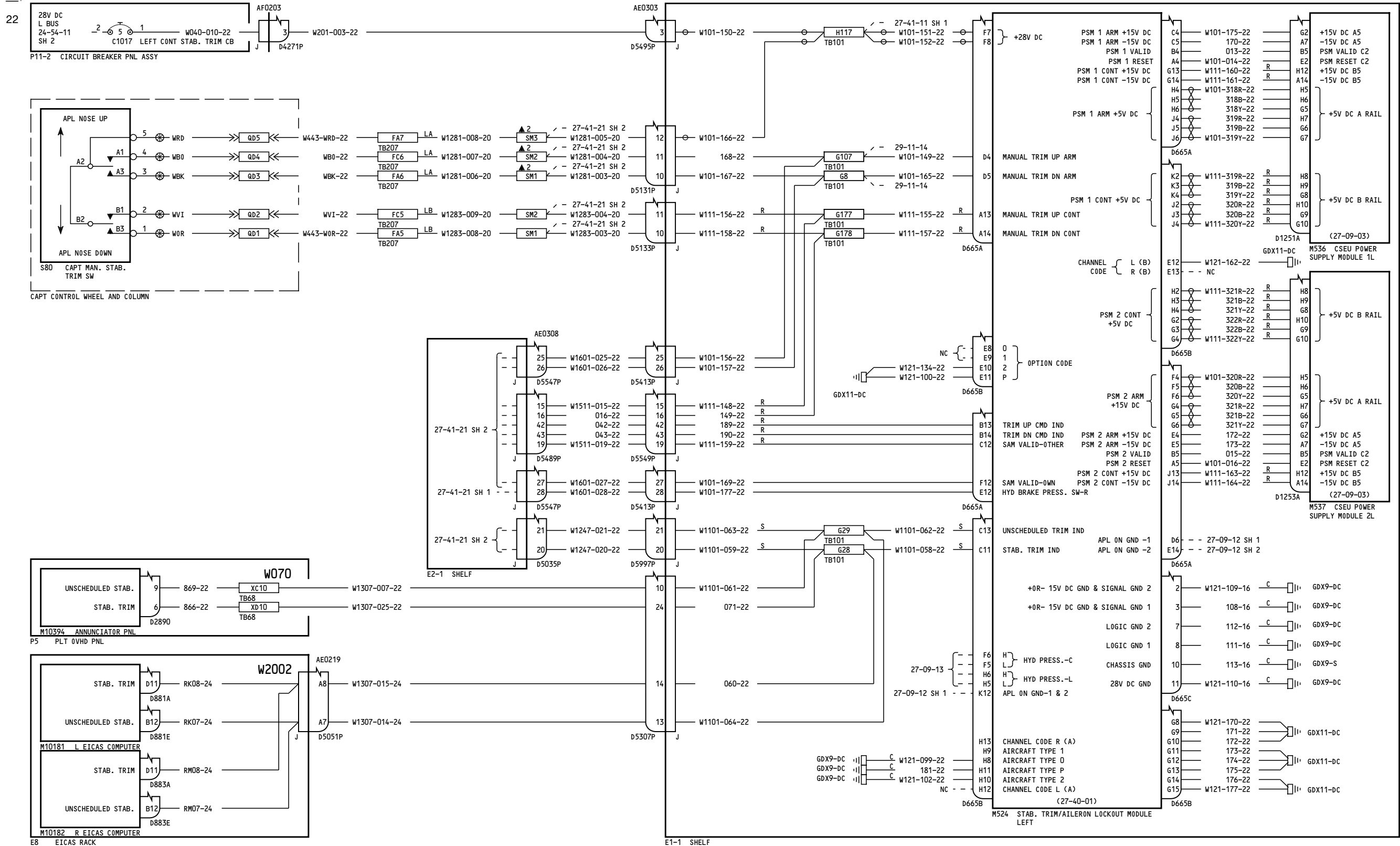

155-166

**MANUAL STABILIZER TRIM-LEFT**  
 27-41-11  
 Page 3.1  
 Sheet 2  
 Jan 21/2005  
 D280T132

**27-41-11**  
 Page 3.1  
 Sheet 2  
 Jan 21/2005

BOEING PROPRIETARY - Copyright © - Unpublished Work - See title page for details.

**27-41-11**  
 Page 3.1  
 Sheet 2  
 Jan 21/2005



38

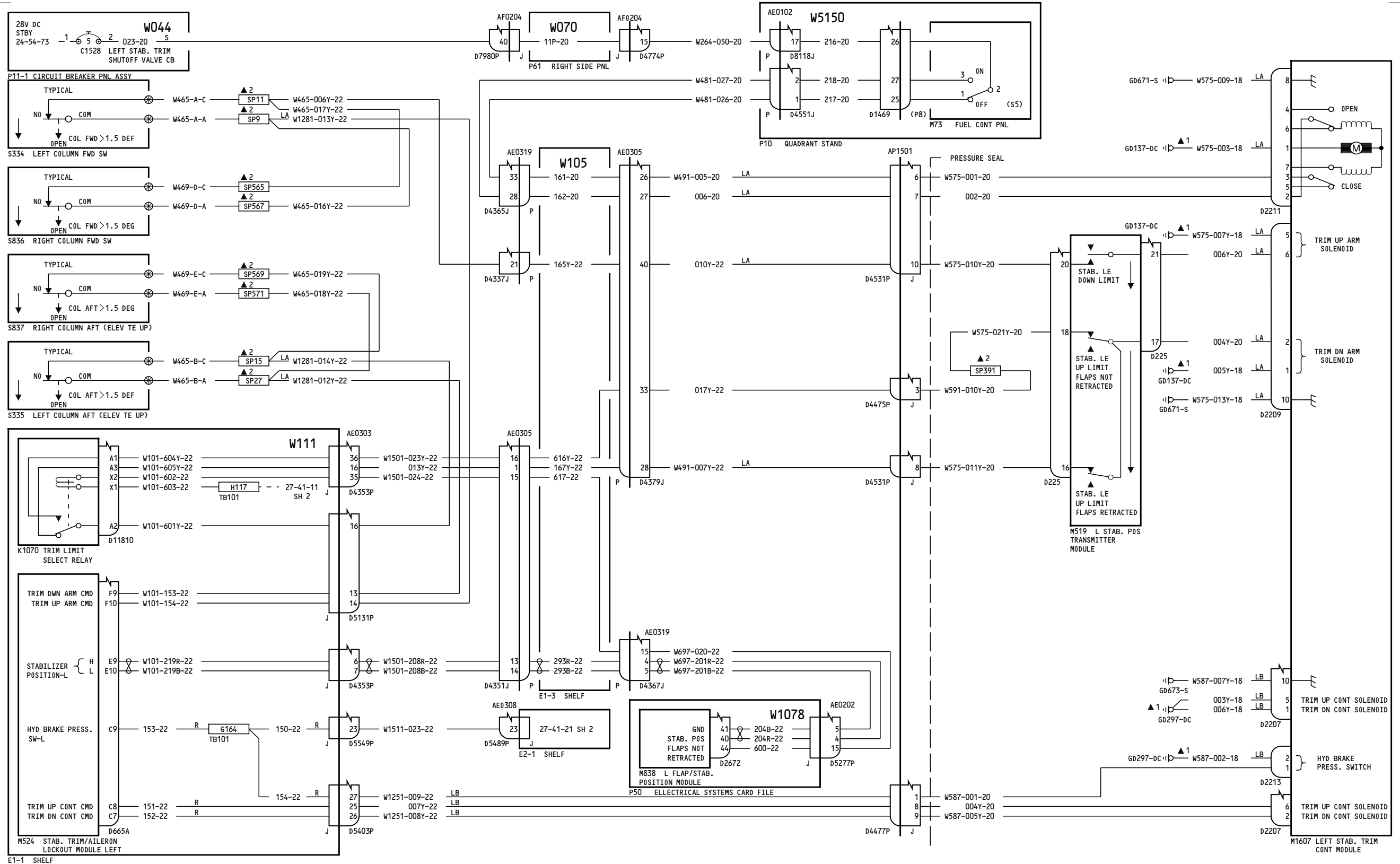

167-199

**MANUAL STABILIZER TRIM-LEFT**

D280T132

27-41-11

Page 4  
Sheet 1  
Jan 21/2005

27-41-11

Page 4  
Sheet 1  
Jan 21/2005

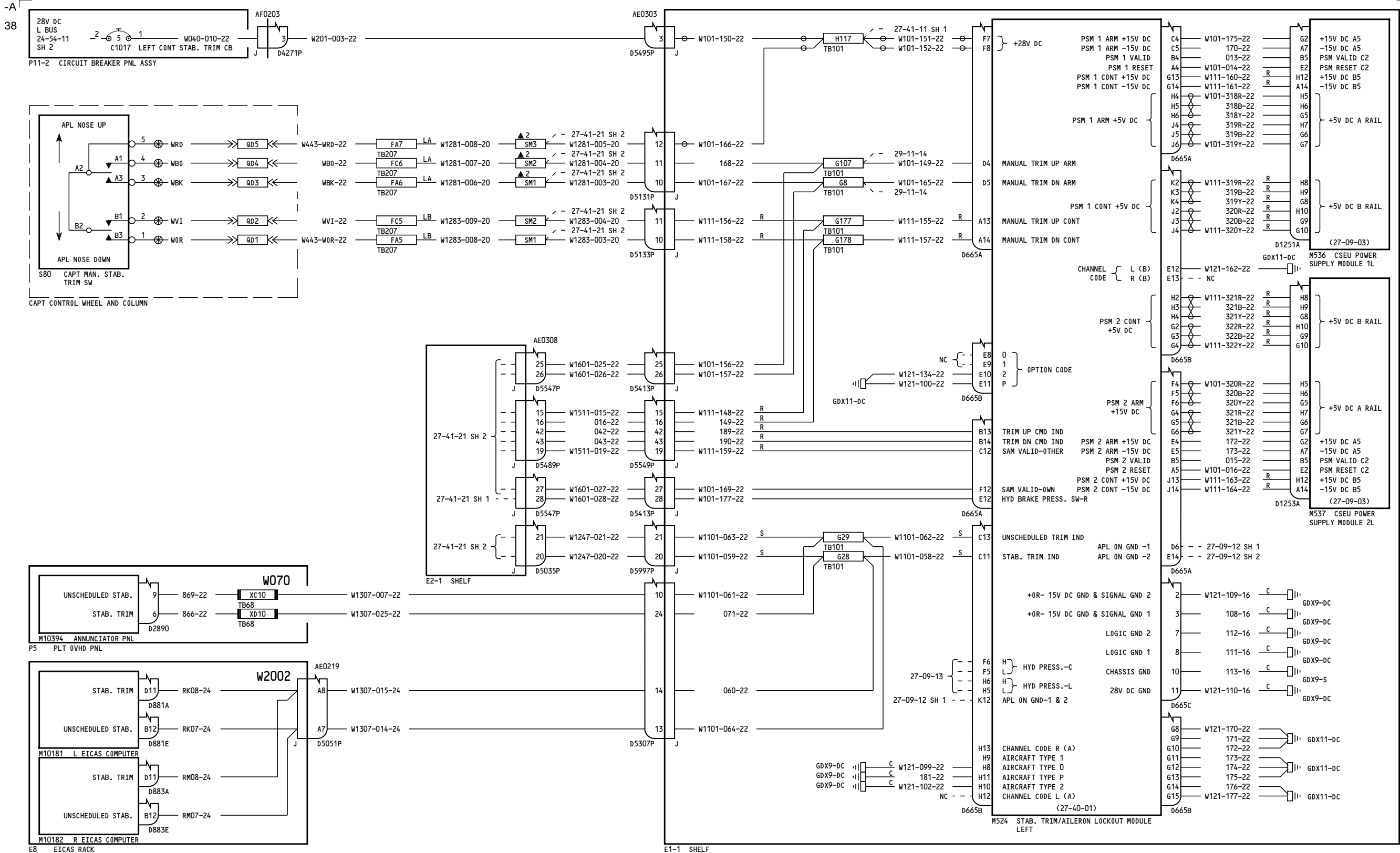

167-199

**MANUAL STABILIZER TRIM-LEFT**

**27-41-11**

Page 4  
Sheet 2  
Jan 21/2005

D280T132

**27-41-11**

Page 4  
Sheet 2  
Jan 21/2005

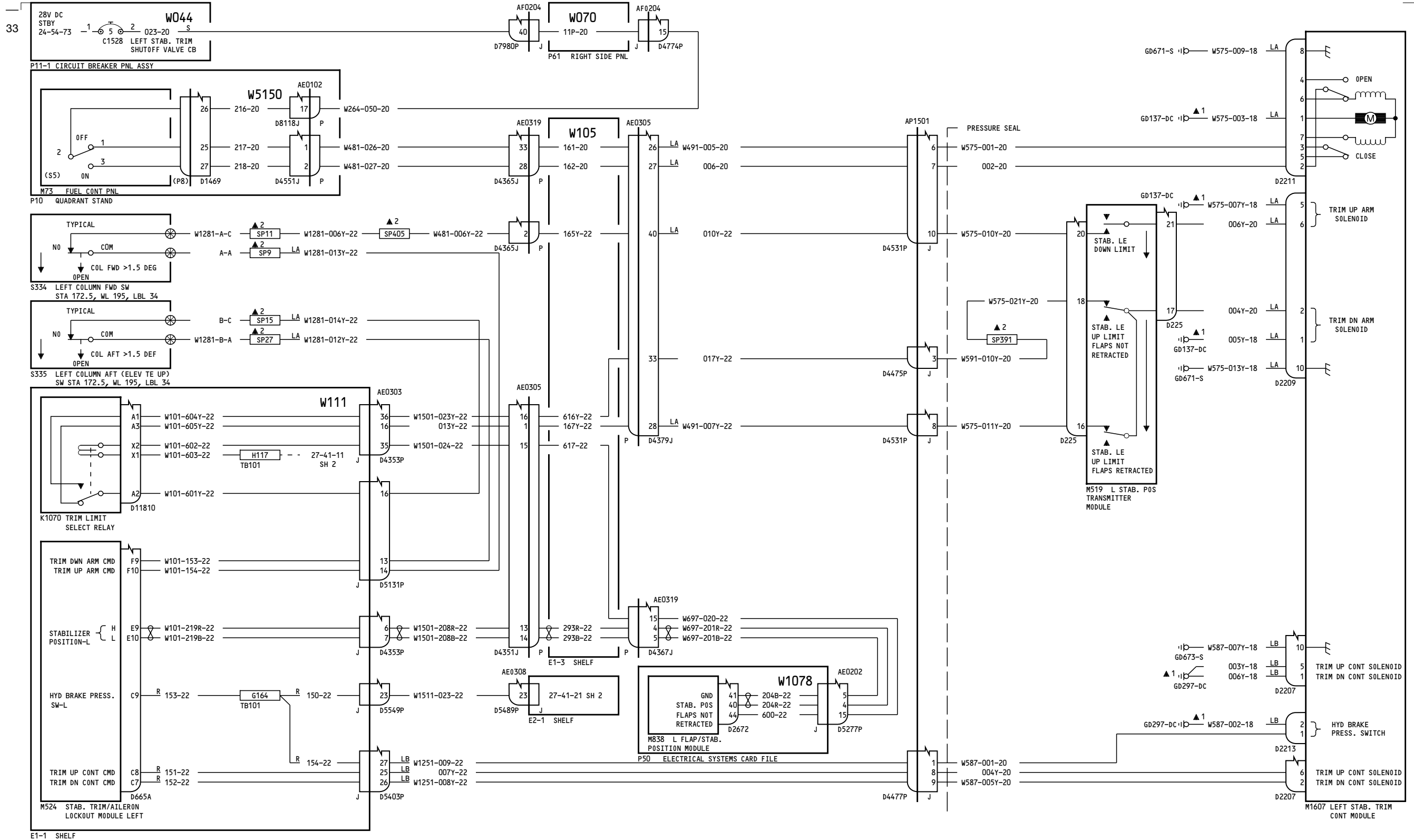

275-277

**MANUAL STABILIZER TRIM-LEFT**

D280T132

**27-41-11**

Page 5  
Sheet 1  
Jan 21/2005

**27-41-11**

Page 5  
Sheet 1  
Jan 21/2005

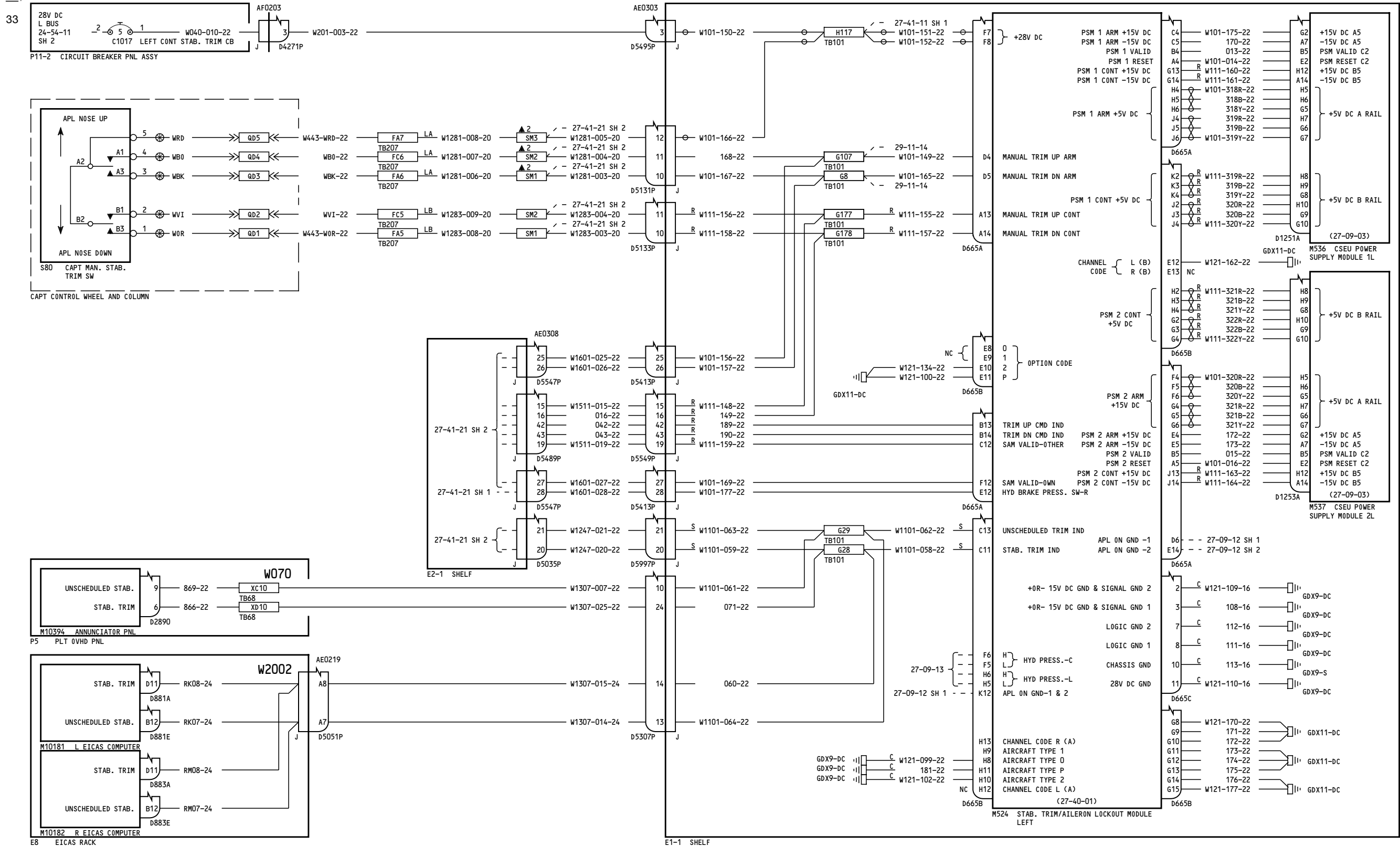

275-277

**MANUAL STABILIZER TRIM-LEFT**

**27-41-11**

Page 5  
Sheet 2  
Jan 21/2005

D280T132

**27-41-11**

Page 5  
Sheet 2  
Jan 21/2005

BOEING PROPRIETARY - Copyright © - Unpublished Work - See title page for details.

**27-41-11**

Page 5  
Sheet 2  
Jan 21/2005

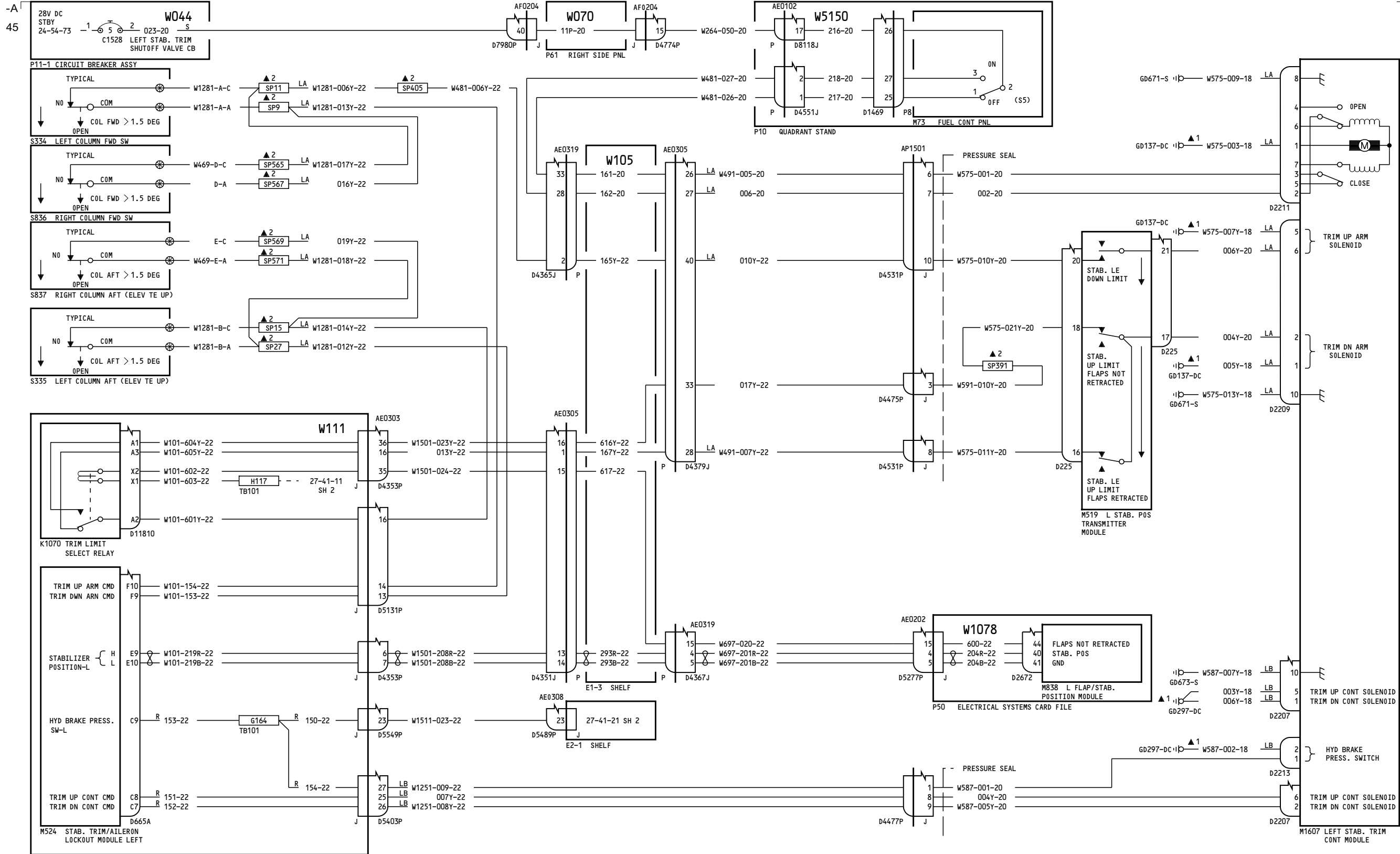

278-299

**MANUAL STABILIZER TRIM-LEFT**

D280T132

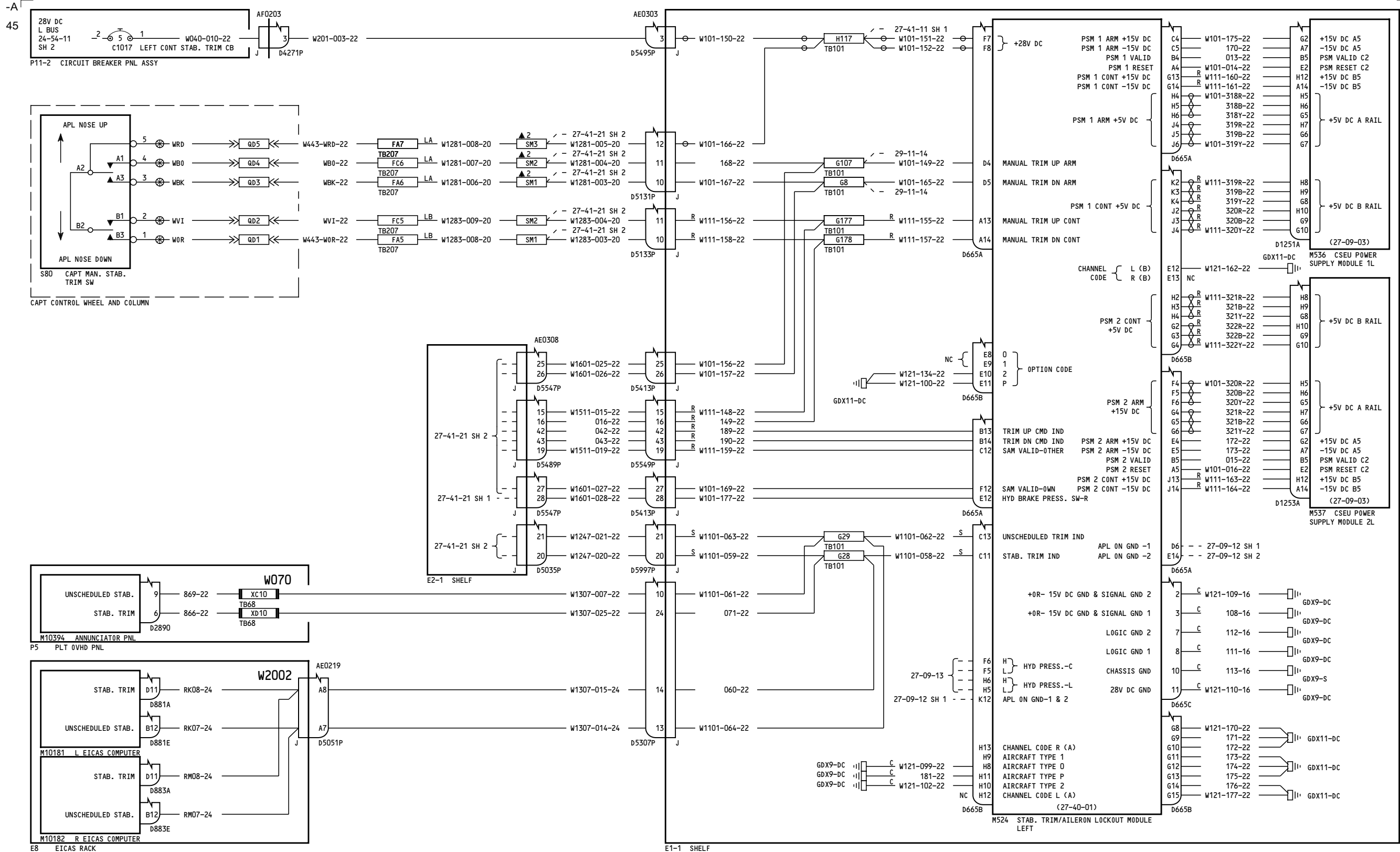

278-299

**MANUAL STABILIZER TRIM-LEFT**

D280T132

**27-41-11**

Page 6  
Sheet 2  
Jan 21/2005

BOEING PROPRIETARY - Copyright © - Unpublished Work - See title page for details.

**27-41-11**

Page 6  
Sheet 2  
Jan 21/2005

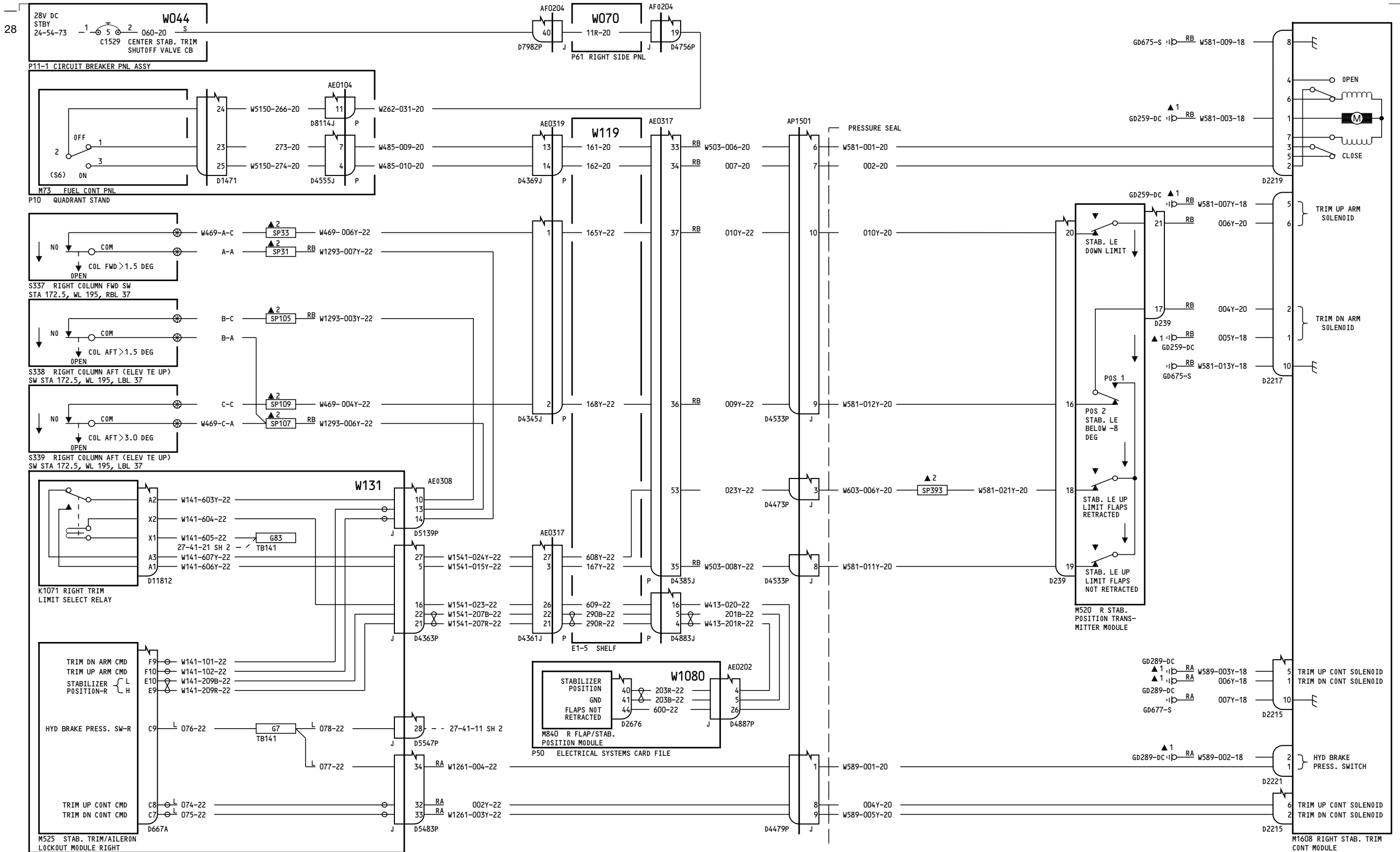

050-099

**MANUAL STABILIZER TRIM-RIGHT**

D280T132

**27-41-21**

Page 1  
Sheet 1  
Jan 21/2005

**27-41-21**

Page 1  
Sheet 1  
Jan 21/2005

28

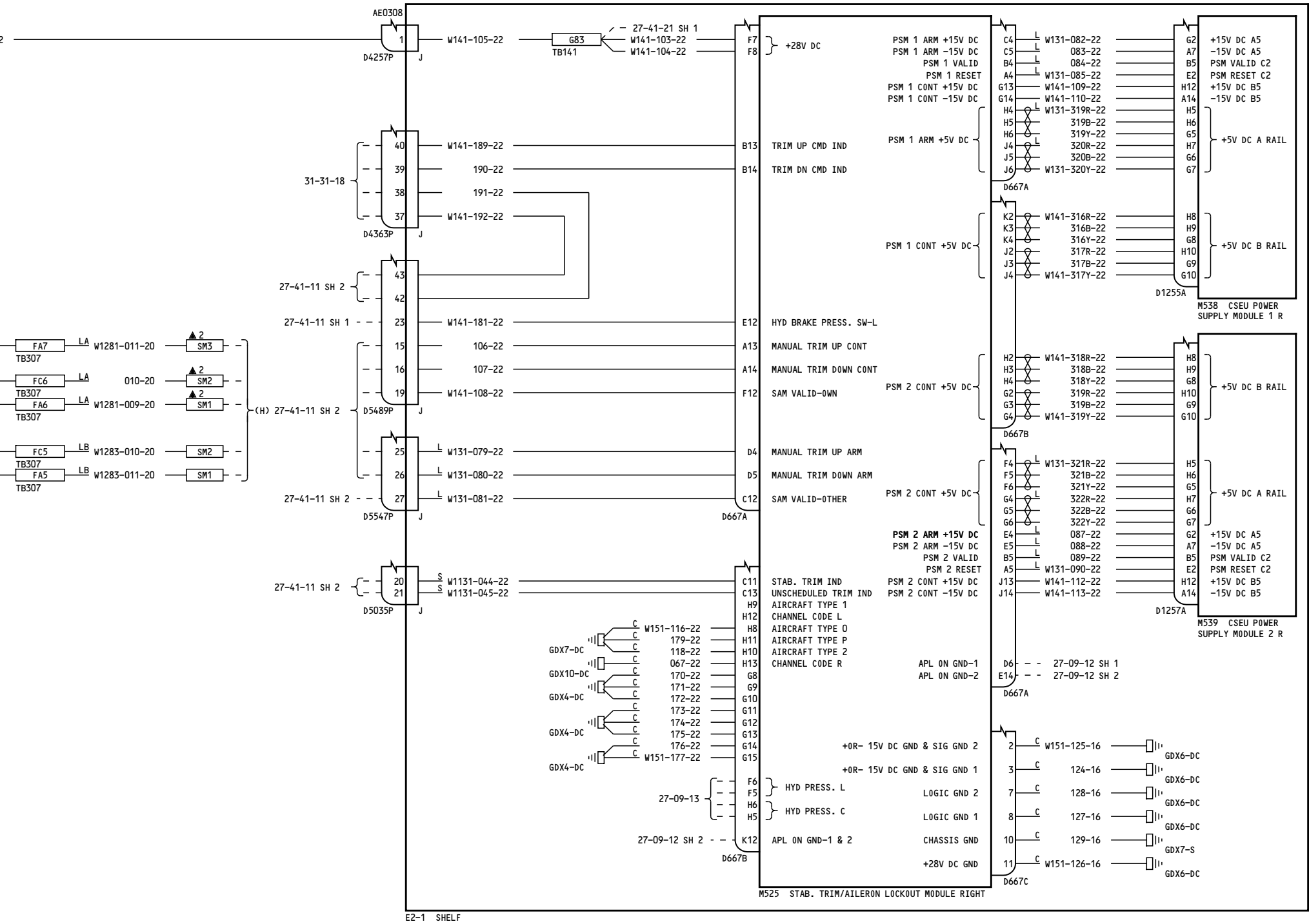
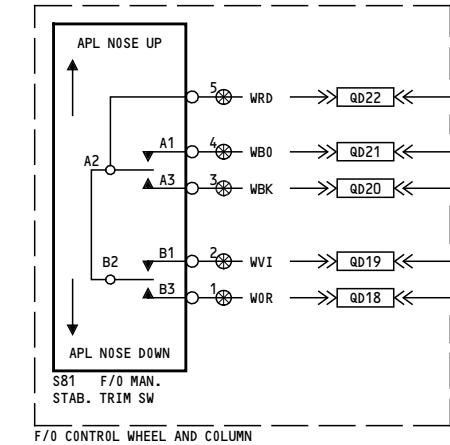
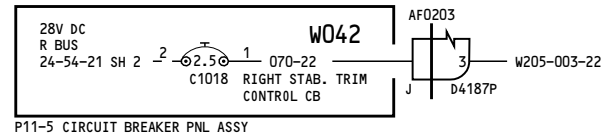

BOEING PROPRIETARY - Copyright © - Unpublished Work - See title page for details.



40

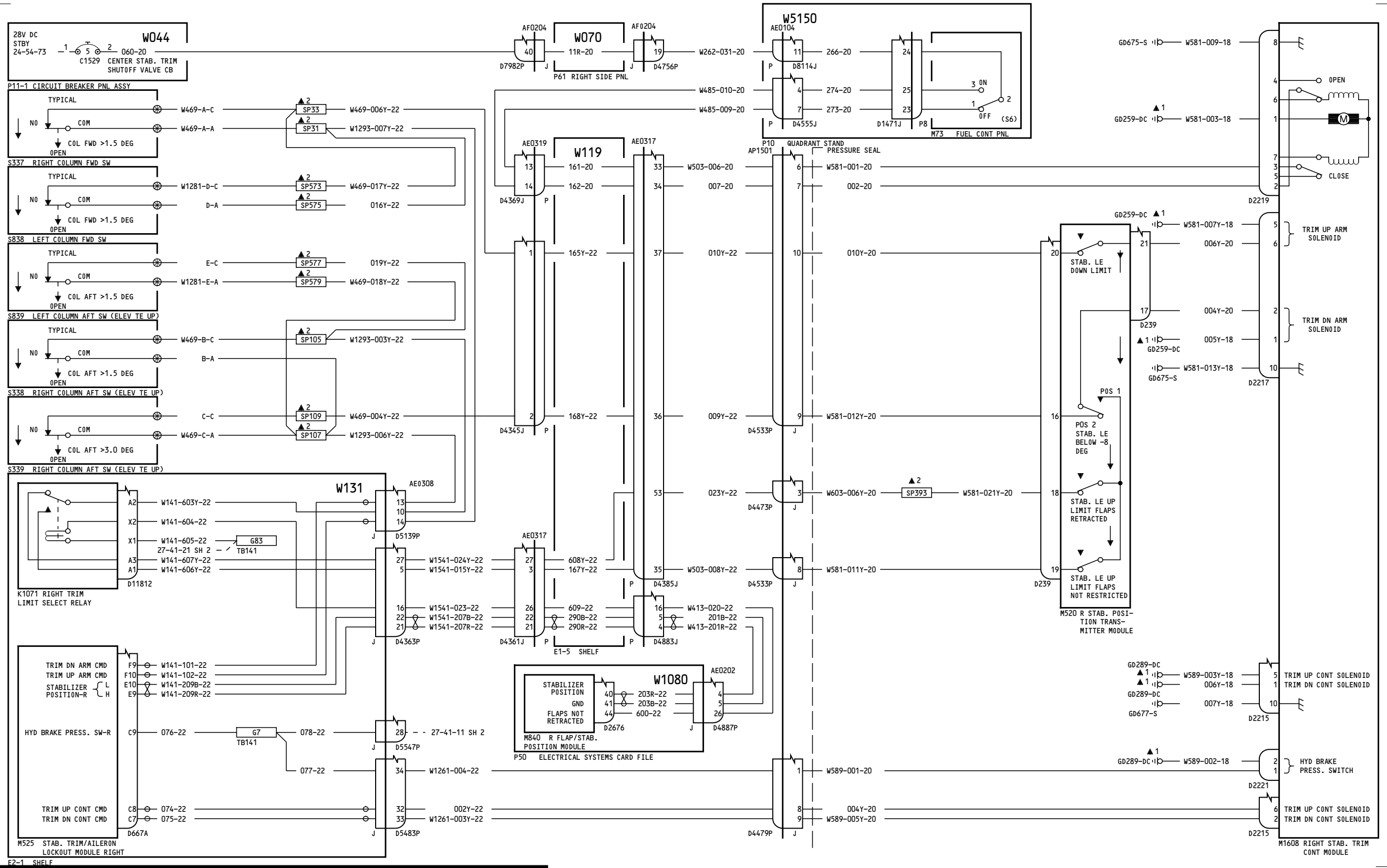

050-051

**MANUAL STABILIZER TRIM-RIGHT**

D280T132

**27-41-21**

Page 1.1  
Sheet 1  
Jan 21/2005

Incorporates  
27-0102 NSC03

**27-41-21**

Page 1.1  
Sheet 1  
Jan 21/2005

28

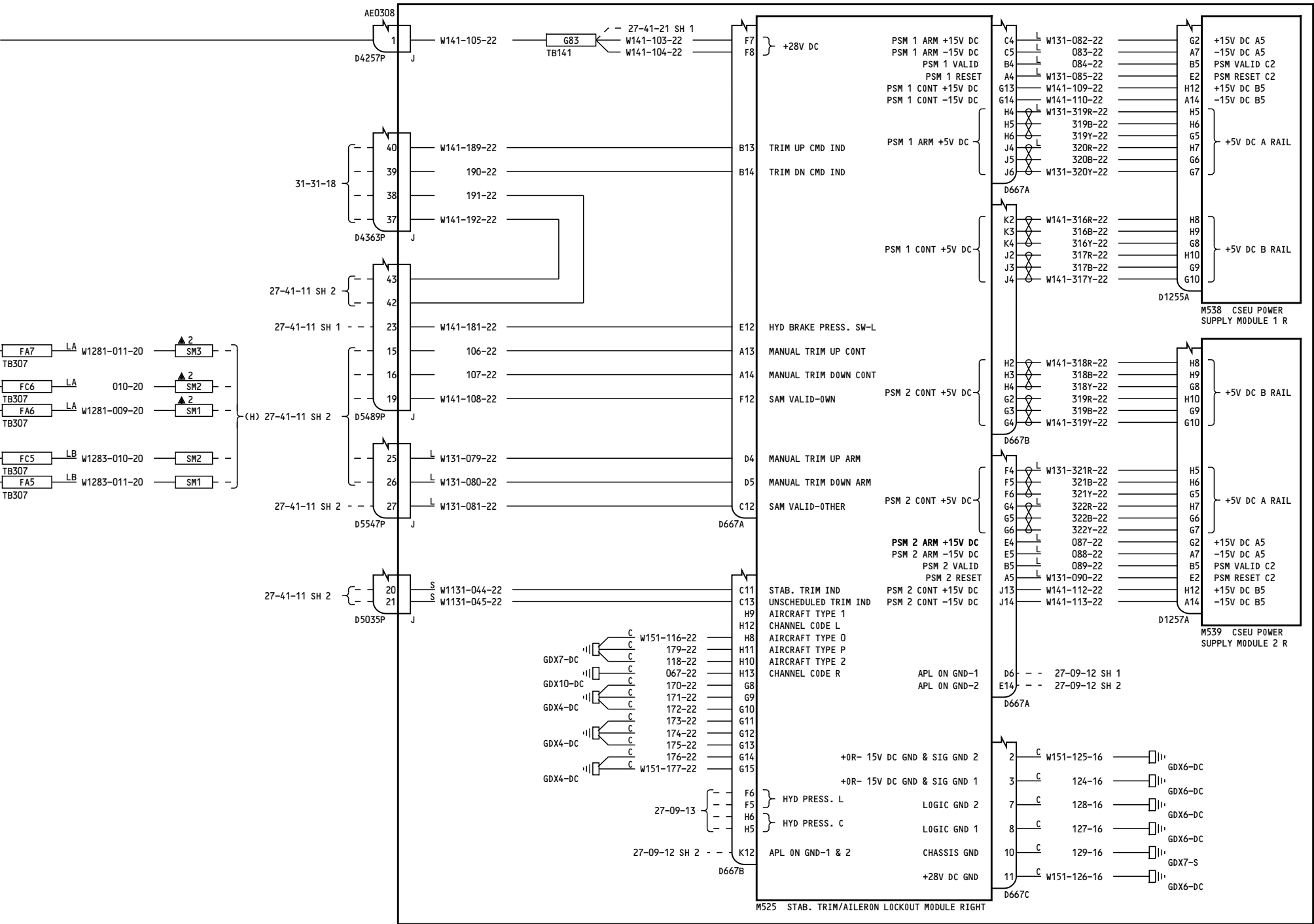
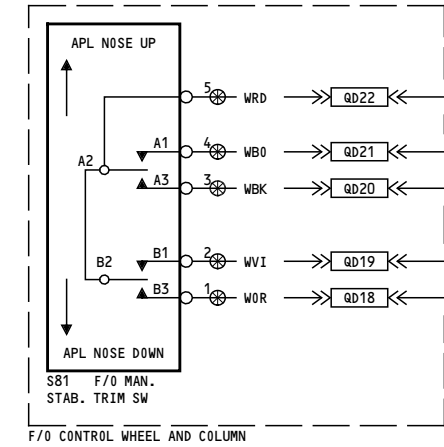
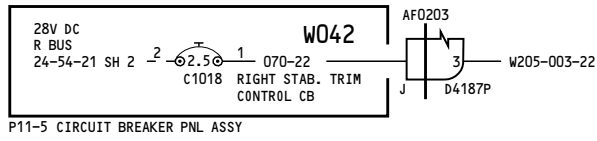

050-051

**MANUAL STABILIZER TRIM-RIGHT**

D280T132

**27-41-21**

Page 1.1  
Sheet 2  
Jan 21/2005

**27-41-21**

Page 1.1  
Sheet 2  
Jan 21/2005

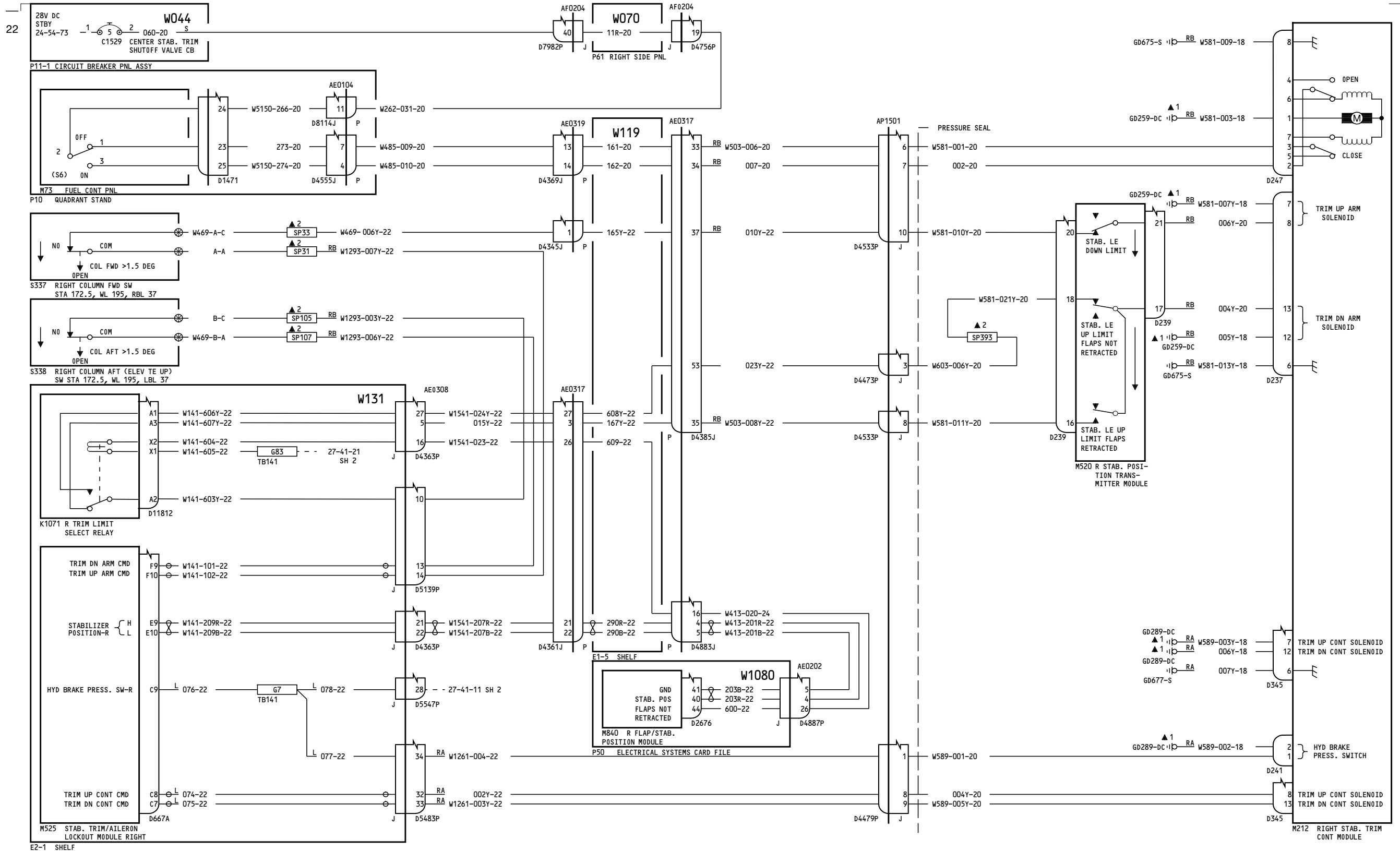

150-154

**MANUAL STABILIZER TRIM-RIGHT**

**27-41-21**

Page 2  
Sheet 1  
Jan 21/2005

D280T132

**27-41-21**

Page 2  
Sheet 1  
Jan 21/2005

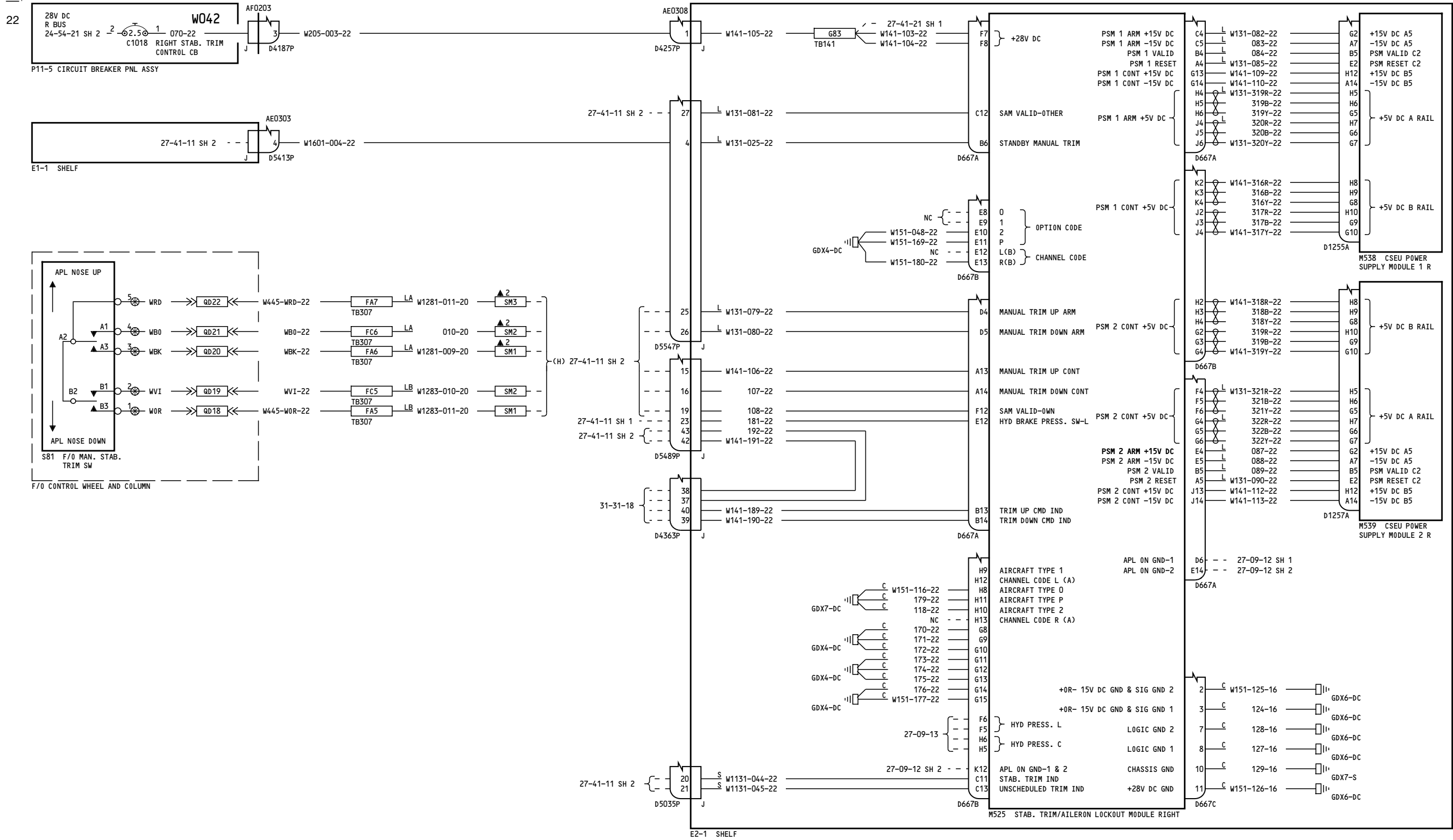

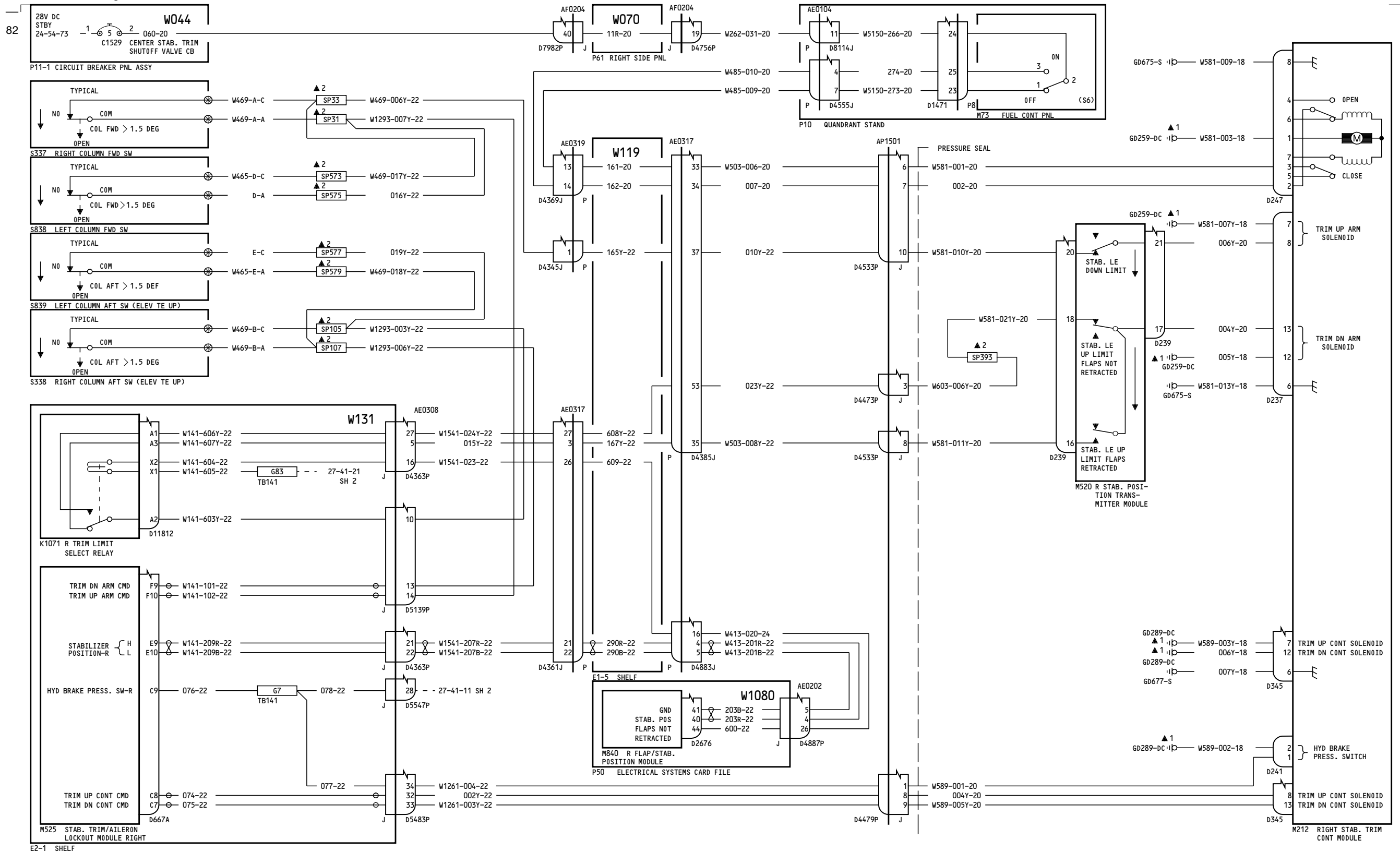

150-154

MANUAL STABILIZER TRIM-RIGHT

D280T132

27-41-21

Page 2.1  
Sheet 1  
Jan 21/2005

Incorporates  
27-0102 NSC03

27-41-21

Page 2.1  
Sheet 1  
Jan 21/2005

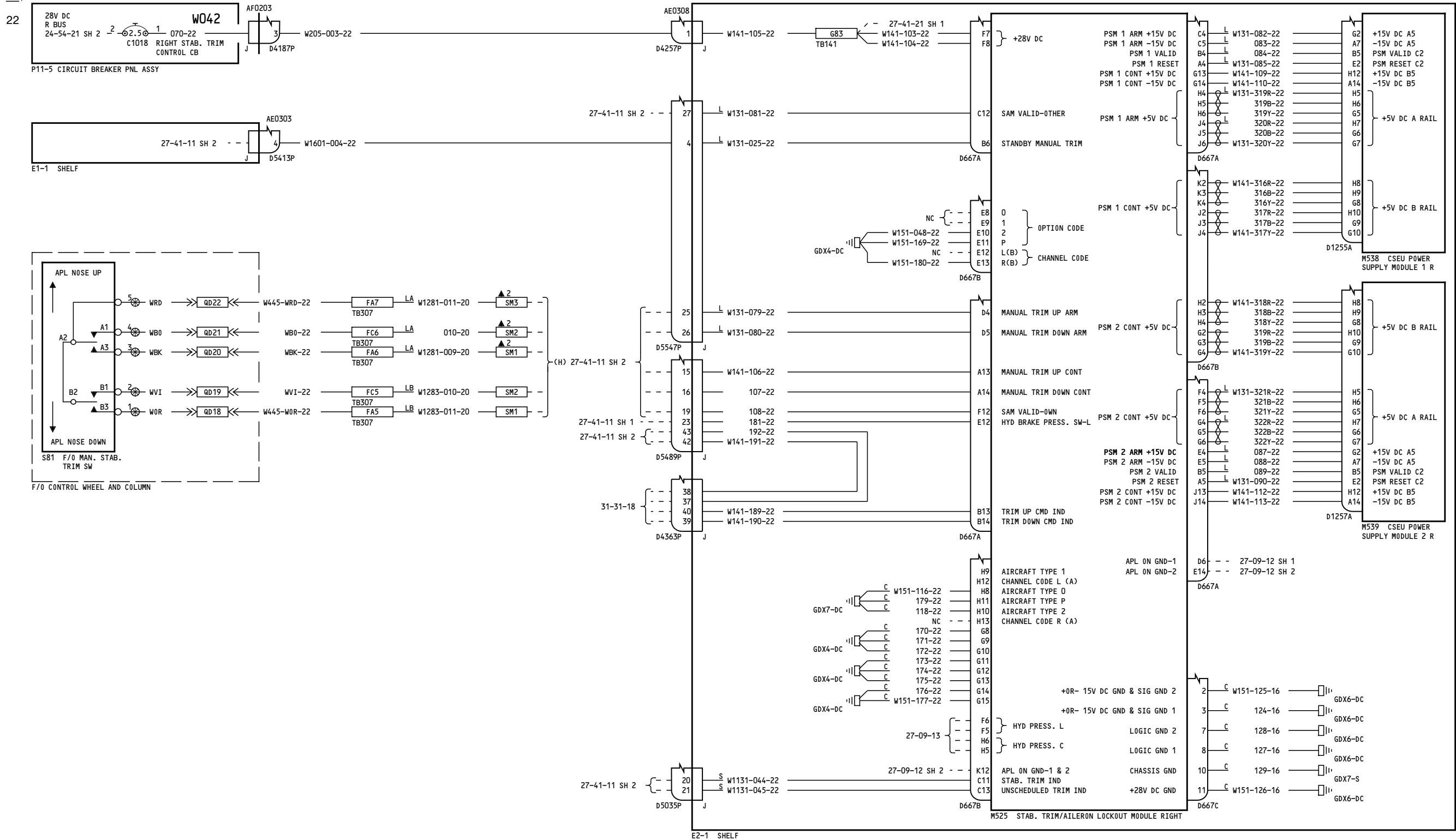

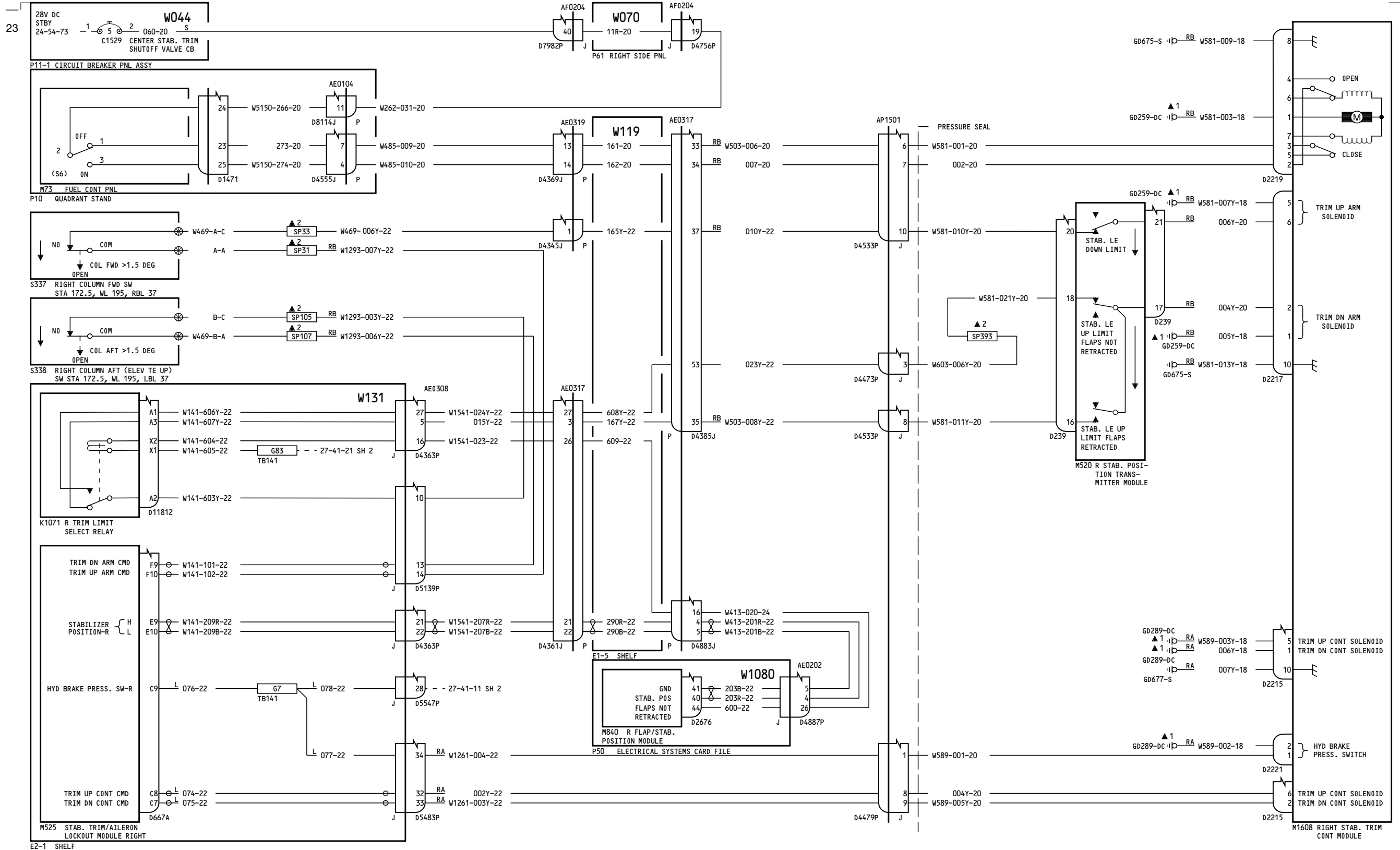

155-166, 275-277

**MANUAL STABILIZER TRIM-RIGHT**

D280T132

**27-41-21**

Page 3  
Sheet 1  
Jan 21/2005

**27-41-21**

Page 3  
Sheet 1  
Jan 21/2005

23

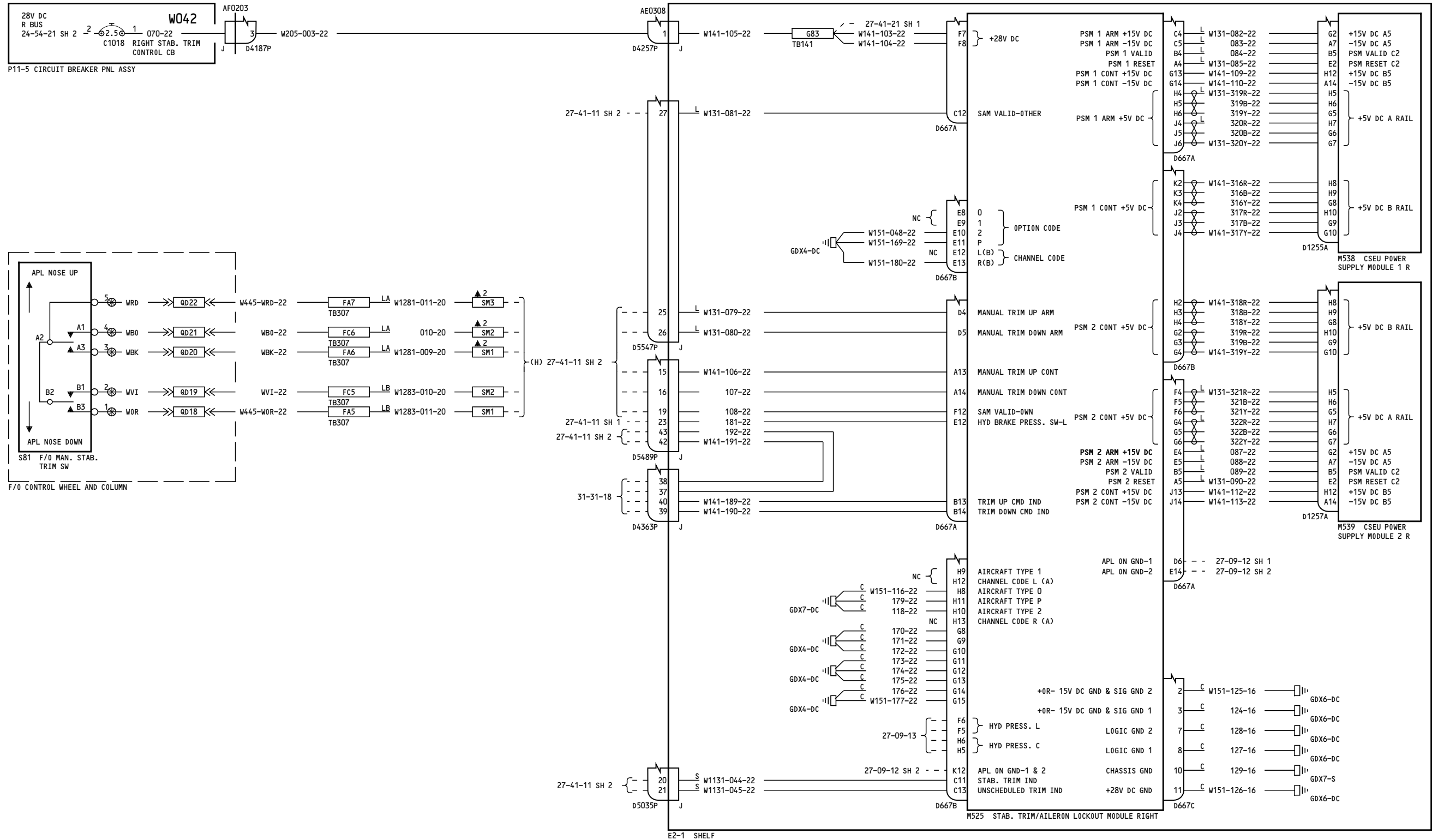

155-166, 275-277

**MANUAL STABILIZER TRIM-RIGHT**

D280T132

**27-41-21**

Page 3  
Sheet 2  
Jan 21/2005

**27-41-21**

Page 3  
Sheet 2  
Jan 21/2005



38

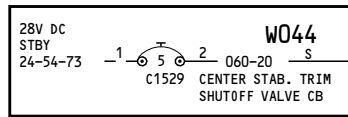

P11-1 CIRCUIT BREAKER PNL ASSY

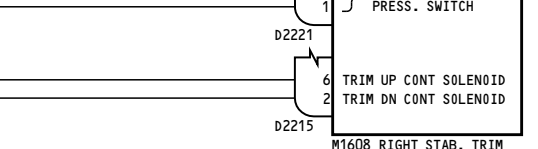
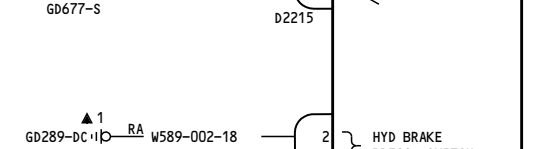
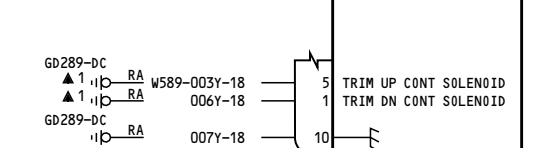
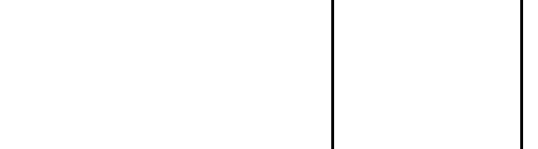
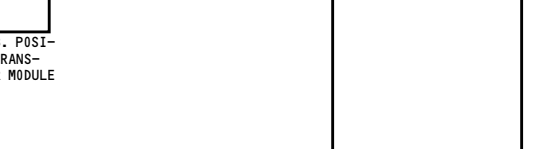
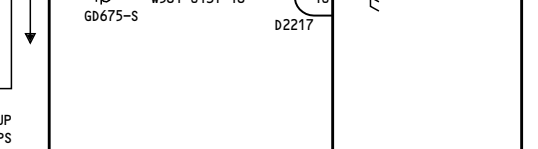
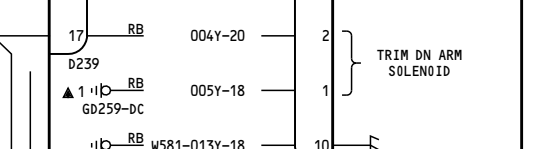
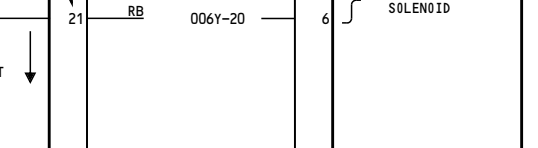
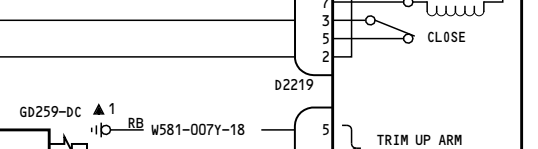
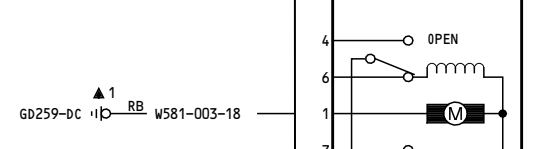
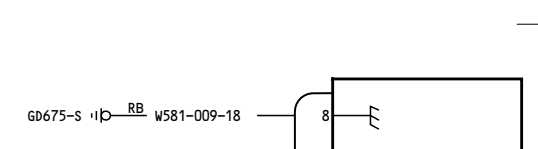
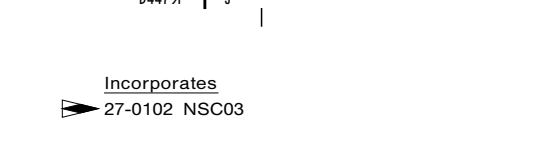
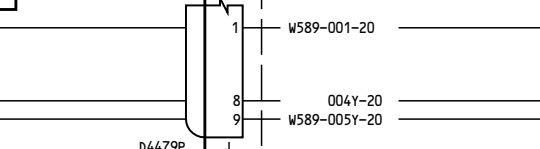
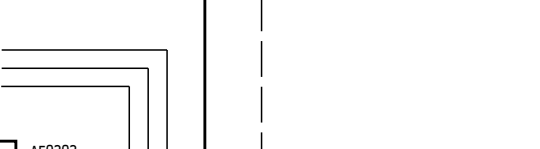
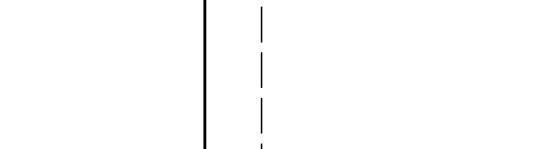
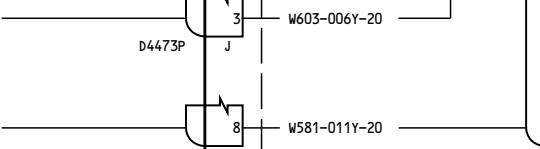
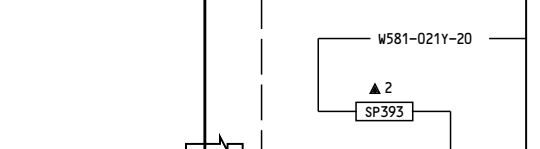
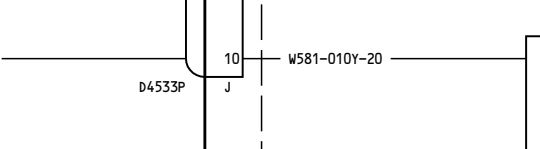
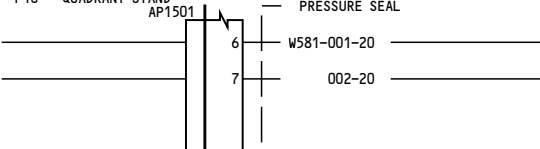
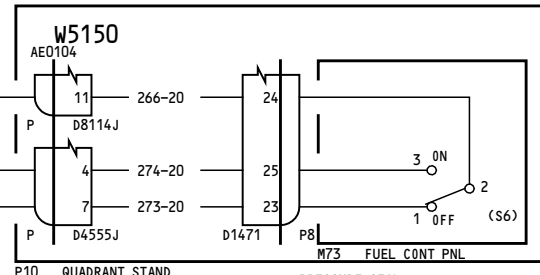
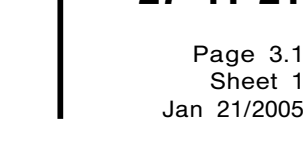
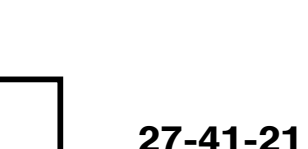
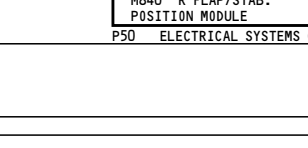
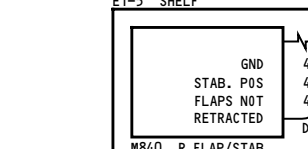
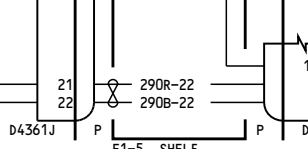
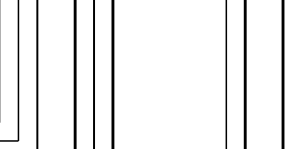
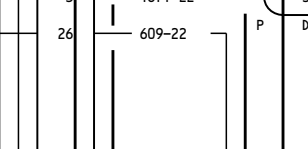
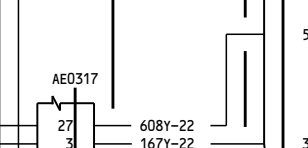
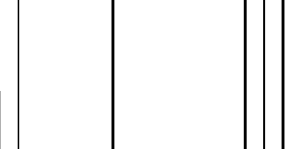
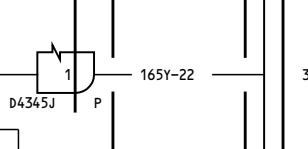
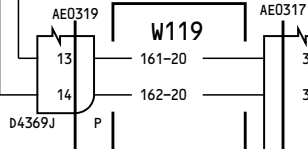
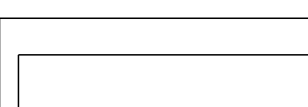
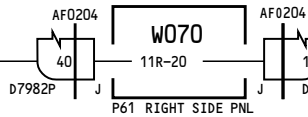
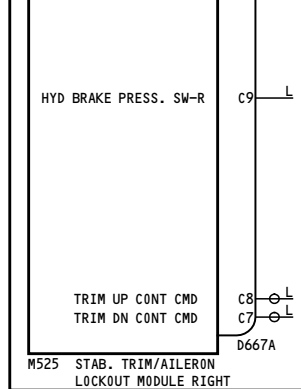
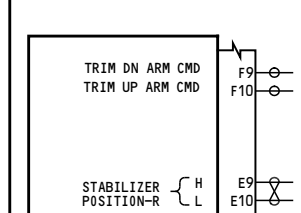
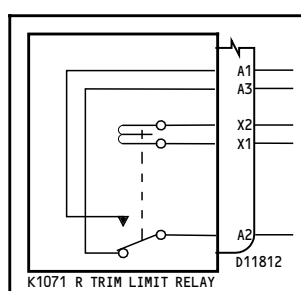
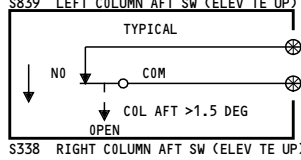
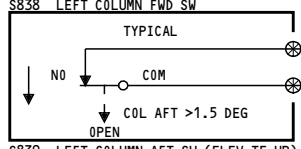
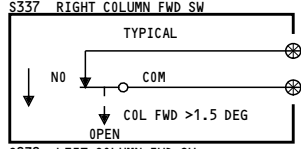
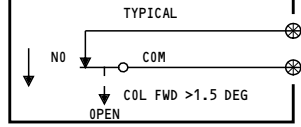

155-166

**MANUAL STABILIZER TRIM-RIGHT**  
D280T132

**27-41-21**  
Page 3.1  
Sheet 1  
Jan 21/2005

Incorporates  
27-0102 NSC03

**27-41-21**  
Page 3.1  
Sheet 1  
Jan 21/2005

23

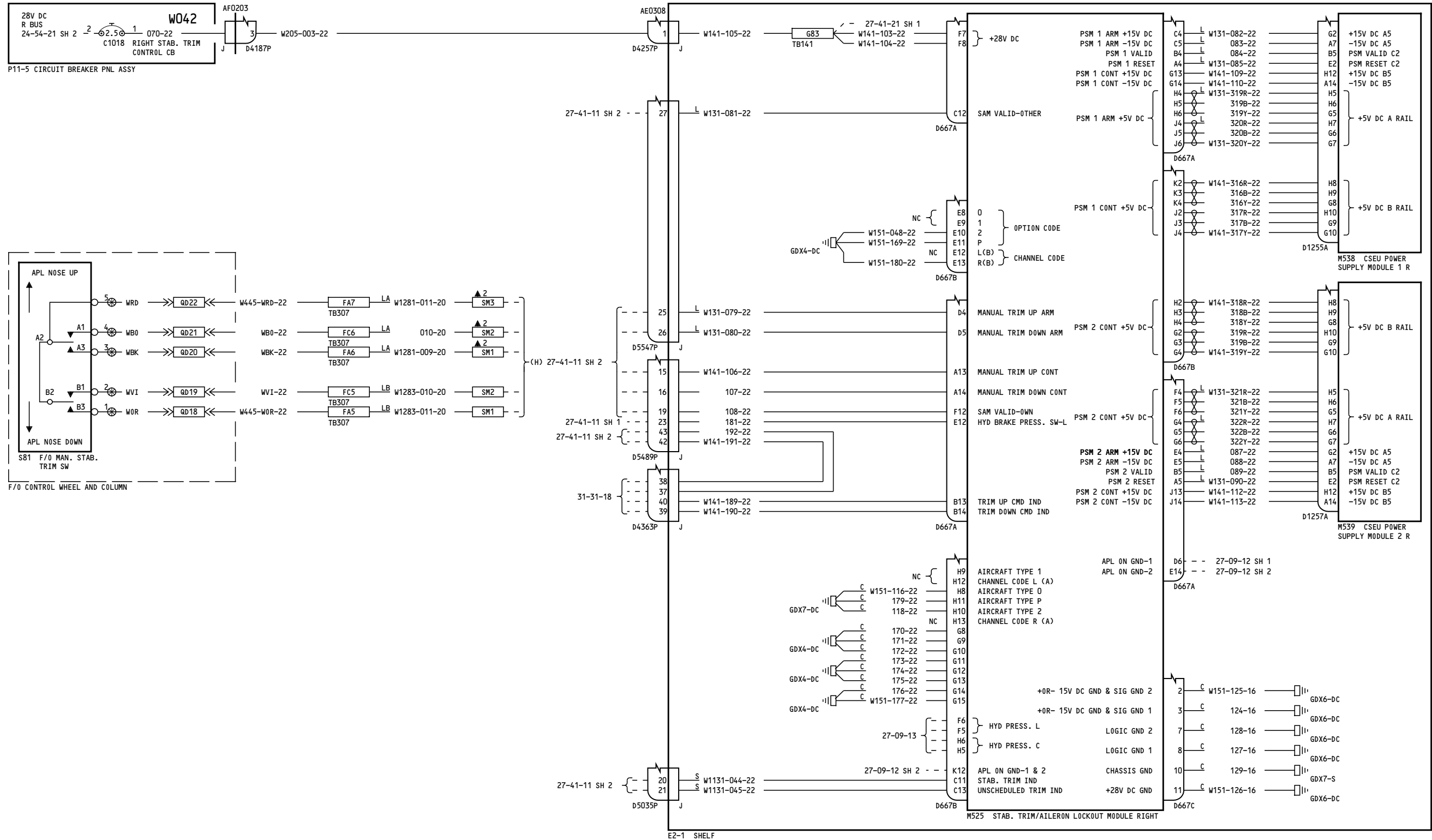

155-166

**MANUAL STABILIZER TRIM-RIGHT**

**27-41-21**

Page 3.1  
Sheet 2  
Jan 21/2005

D280T132

**27-41-21**

Page 3.1  
Sheet 2  
Jan 21/2005

38

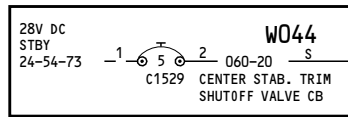

P11-1 CIRCUIT BREAKER PNL ASSY

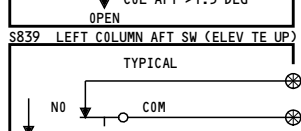
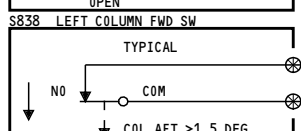
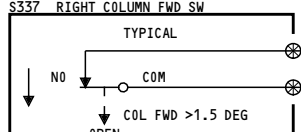
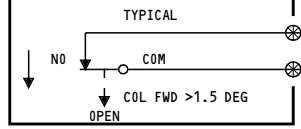

W469-A-C, W469-A-A, W465 D-C, D-A, E-C, W465 E-A, W469-B-C, W469-B-A

SP33, SP31, SP573, SP575, SP577, SP579, SP105, SP107

W469-006Y-22, W469-007Y-22, W469-017Y-22, 016Y-22, 019Y-22, W469-018Y-22, W1293-003Y-22, W1293-006Y-22

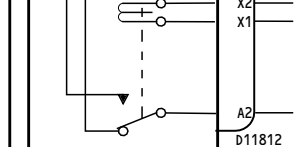

W141-101-22, W141-102-22, W141-209R-22, W141-209B-22

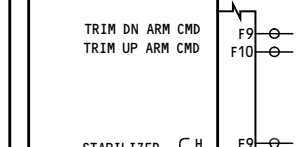

W141-101-22, W141-102-22, W141-209R-22, W141-209B-22, 076-22, 078-22, 077-22, 074-22, 075-22

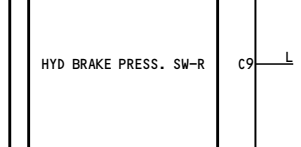

W1261-004-22, 002Y-22, W1261-003Y-22

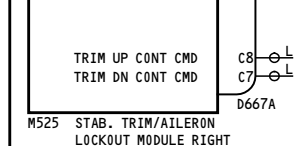

W581-001-20, 002-20, 010Y-22, 023Y-22, W581-011Y-20, W581-013Y-18, W581-010Y-20, W581-007Y-18, W581-003Y-18, W581-006Y-20, 005Y-18, W589-001-20, 004Y-20, W589-005Y-20



W262-031-20, W485-010-20, W485-009-20, W503-006-20, 007-20, 010Y-22, 023Y-22, W503-008Y-22, W413-020-24, W413-201R-22, W413-201B-22



W581-009-18, W581-003-18, W581-007Y-18, W581-006Y-20, W581-010Y-20, W581-011Y-20, W581-013Y-18, W589-001-20, W589-002-18, W589-005Y-20, W581-009-18, W581-003-18, W581-007Y-18, W581-006Y-20, W581-010Y-20, W581-011Y-20, W581-013Y-18, W589-001-20, W589-002-18, W589-005Y-20



TRIM UP ARM SOLENOID, TRIM DN ARM SOLENOID, TRIM UP CONT SOLENOID, TRIM DN CONT SOLENOID, HYD BRAKE PRESS. SWITCH, TRIM UP CONT SOLENOID, TRIM DN CONT SOLENOID

MANUAL STABILIZER TRIM-RIGHT

27-41-21

Page 4  
Sheet 1  
Jan 21/2005

D280T132

27-41-21

Page 4  
Sheet 1  
Jan 21/2005

38

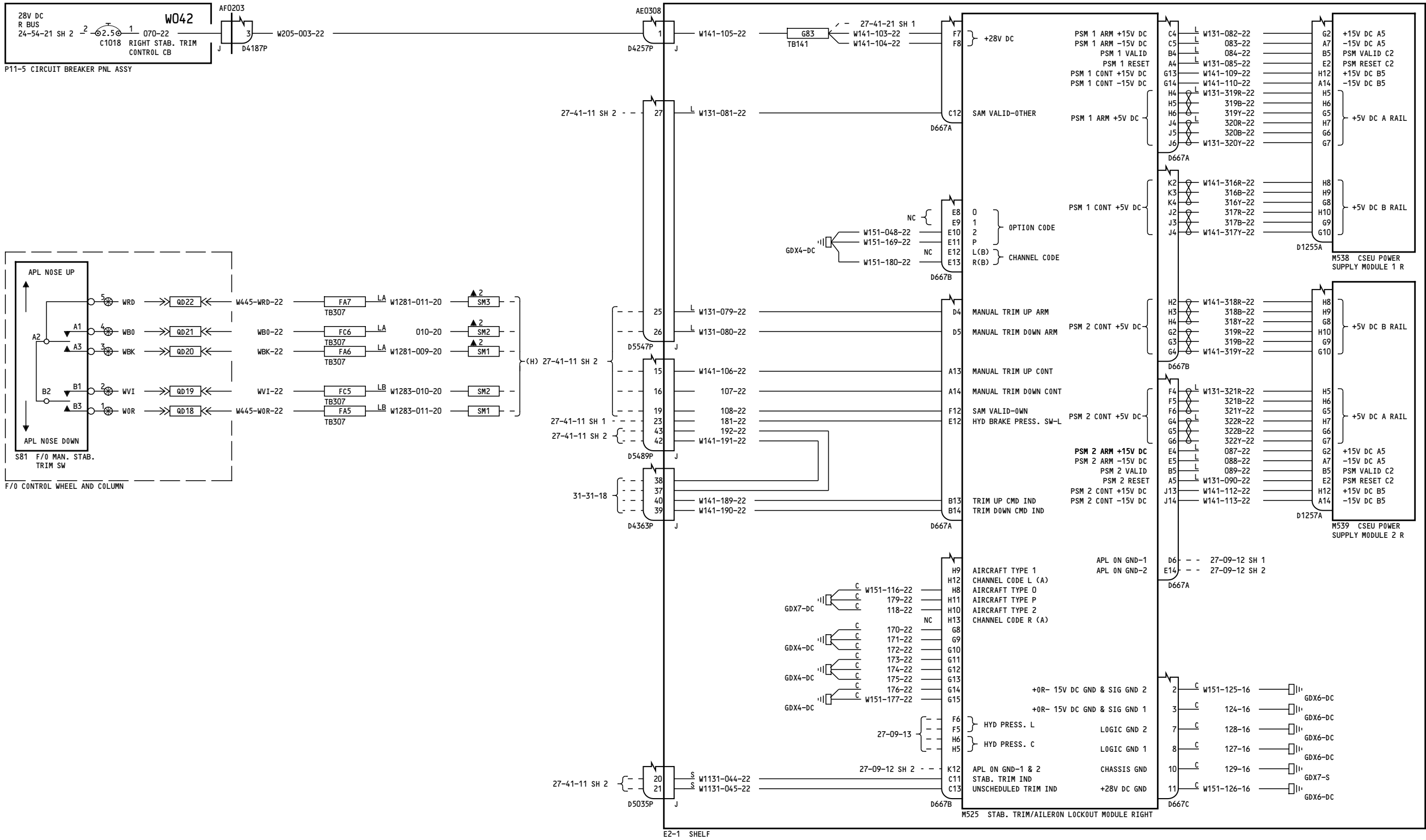

-A  
39

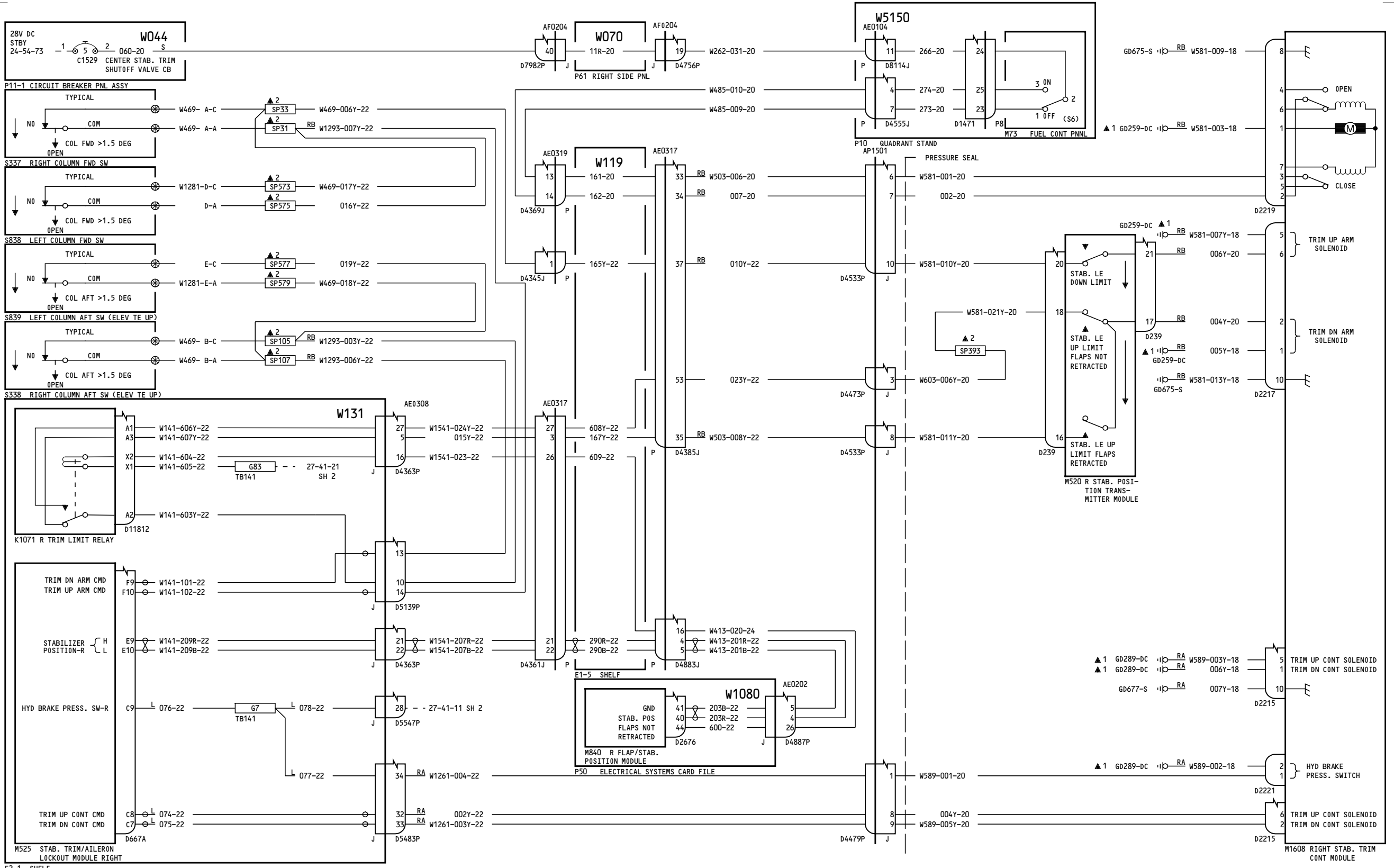

278-299

**MANUAL STABILIZER TRIM-RIGHT**

D280T132

**27-41-21**

Page 5  
Sheet 1  
Jan 21/2005

**27-41-21**

Page 5  
Sheet 1  
Jan 21/2005

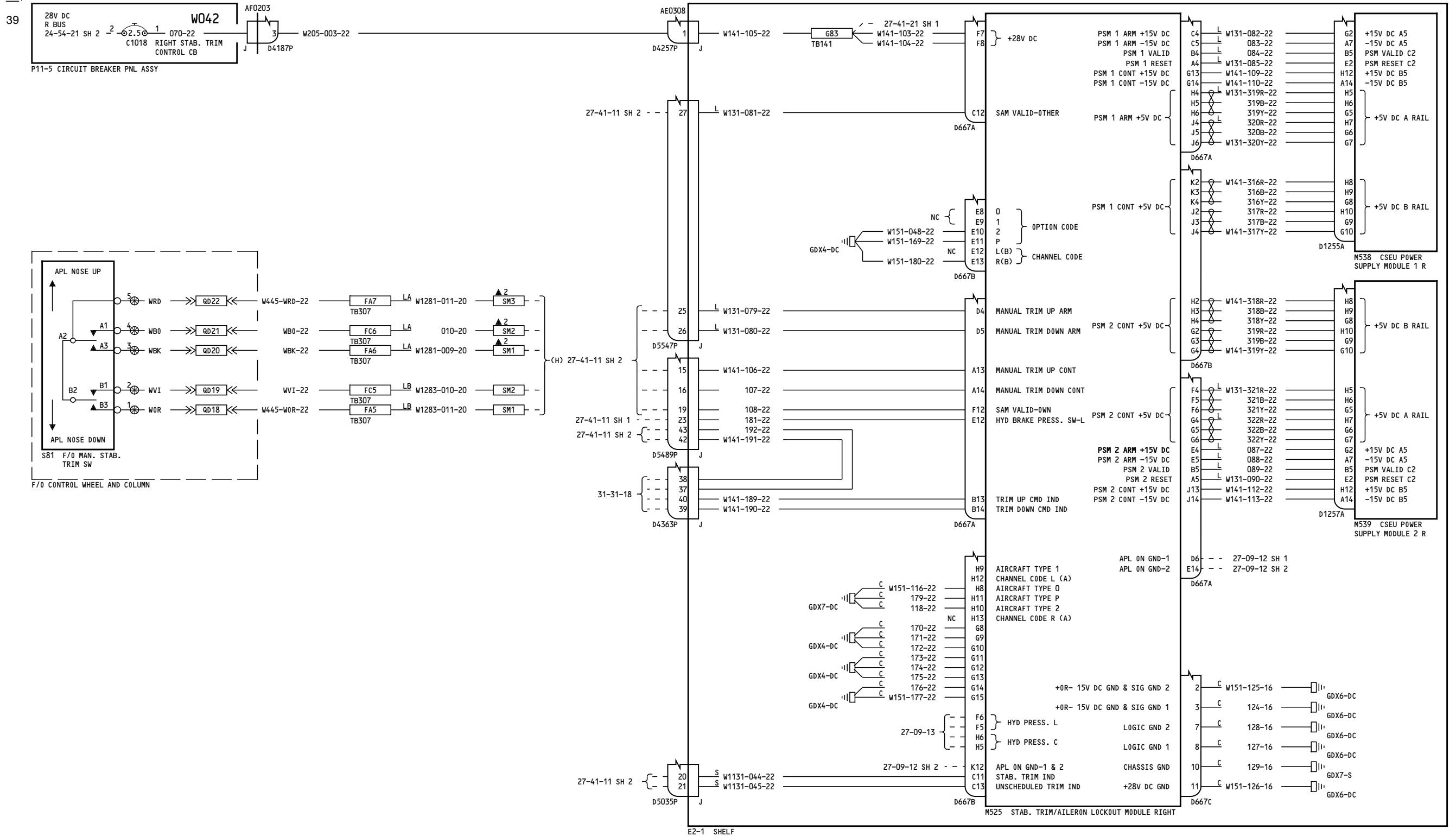

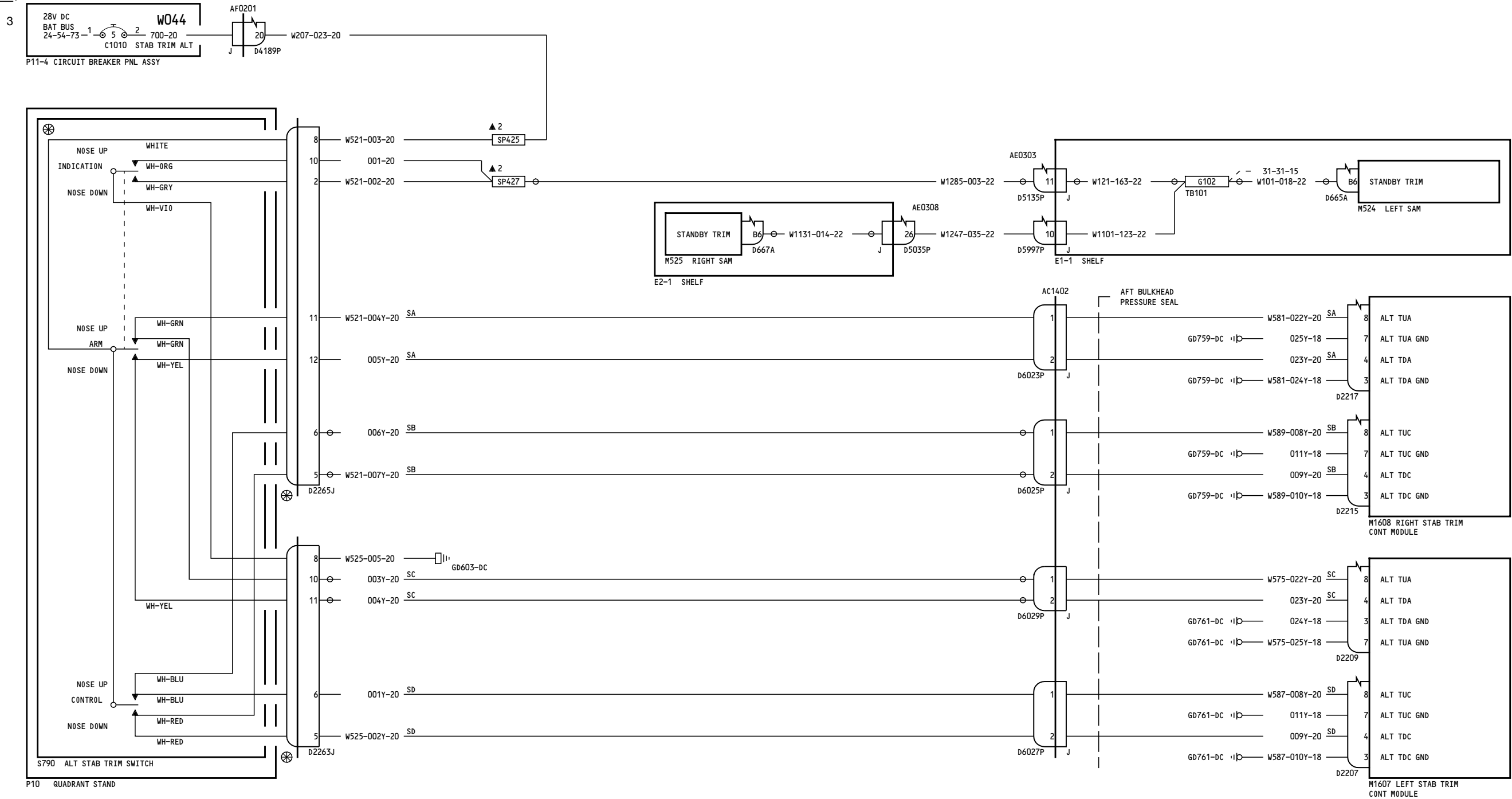

050-099, 155-199, 275-299

**MANUAL STABILIZER TRIM-  
ALTERNATE CONTROL**

**27-41-31**

Page 1

Jan 21/2005

D280T132

**27-41-31**

Page 1

Jan 21/2005

-A  
7

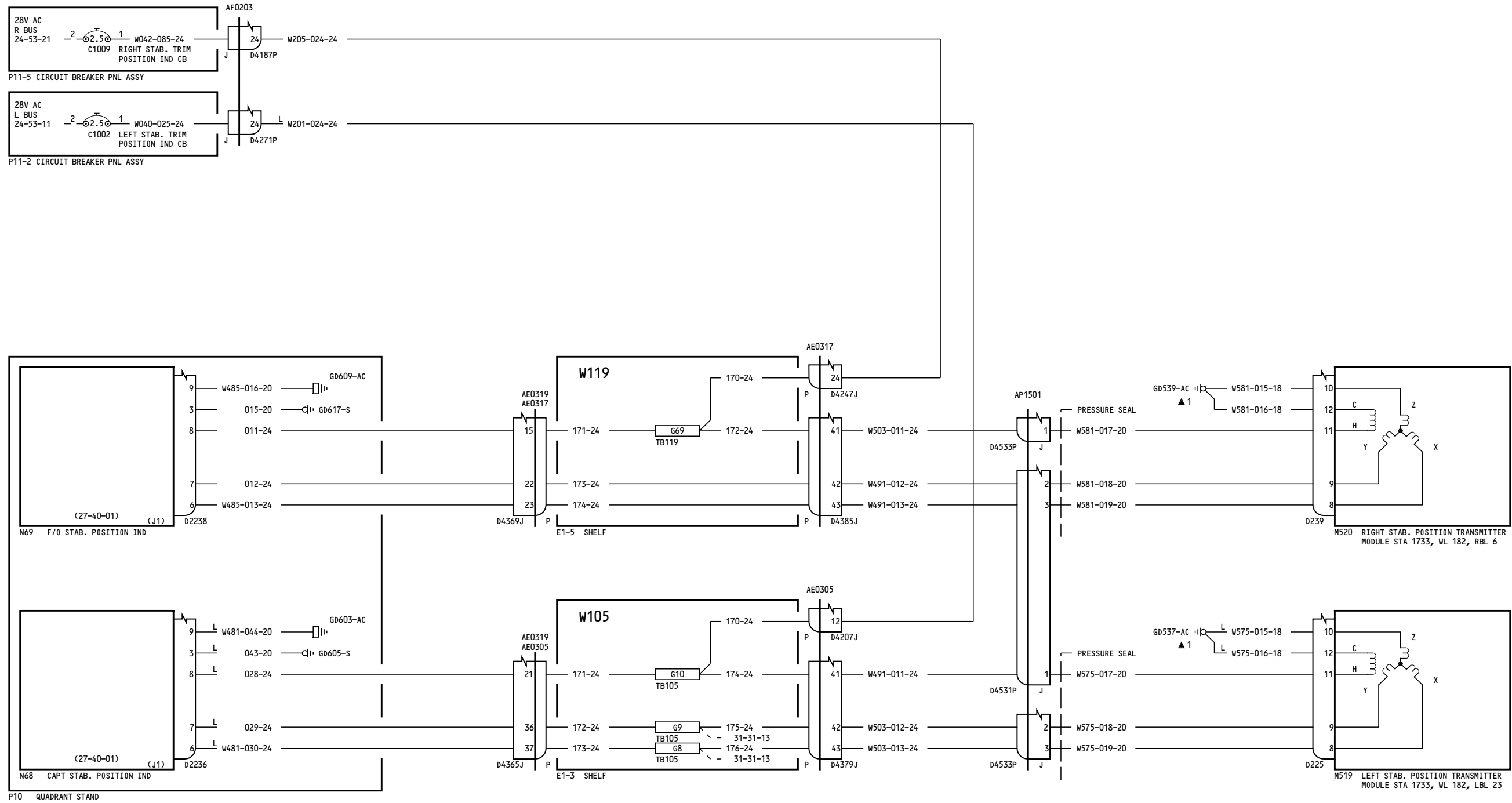

050-099, 162-164

**STABILIZER TRIM POSITION INDICATOR**

**27-48-11**

Page 1

Jan 21/2005

D280T132

**27-48-11**

Page 1

Jan 21/2005



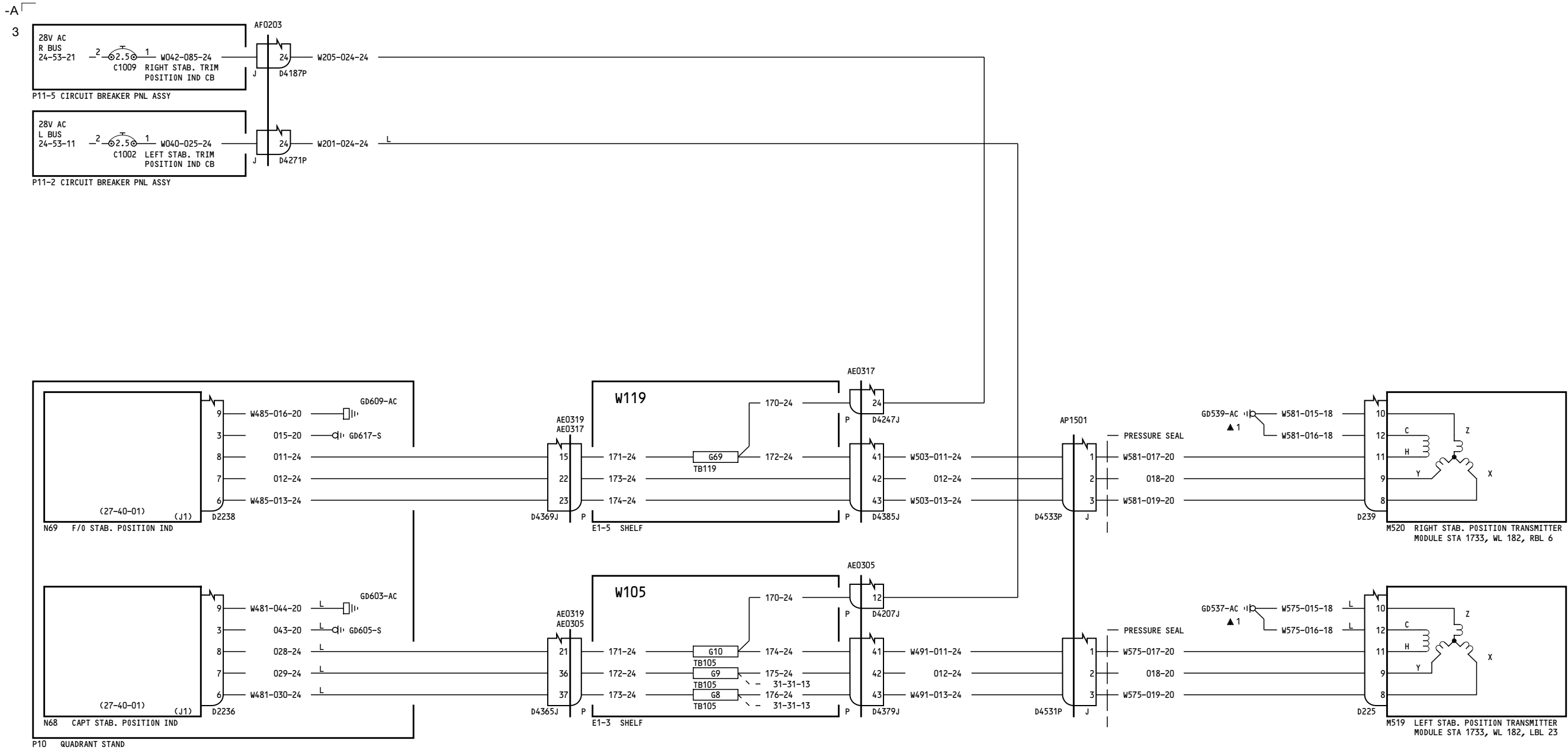

150-154, 275-276	<p align="center"><b>STABILIZER TRIM POSITION INDICATOR</b></p> <p align="center">D280T132</p>
------------------	--

**27-48-11**

Page 2

Jan 21/2005

**27-48-11**

Page 2

Jan 21/2005

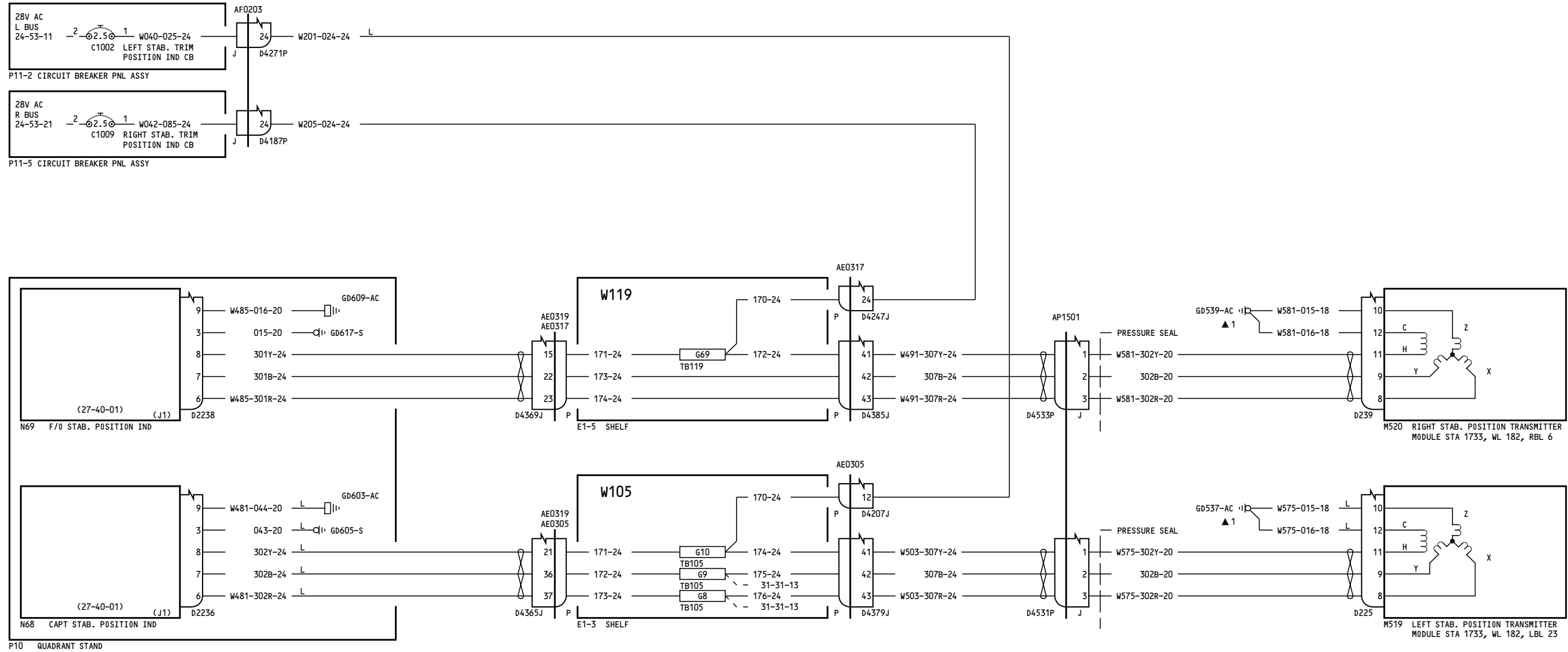

155-156, 165-166

**STABILIZER TRIM POSITION INDICATOR**

**27-48-11**

Page 3

Jan 21/2005

D280T132

**27-48-11**

Page 3

Jan 21/2005

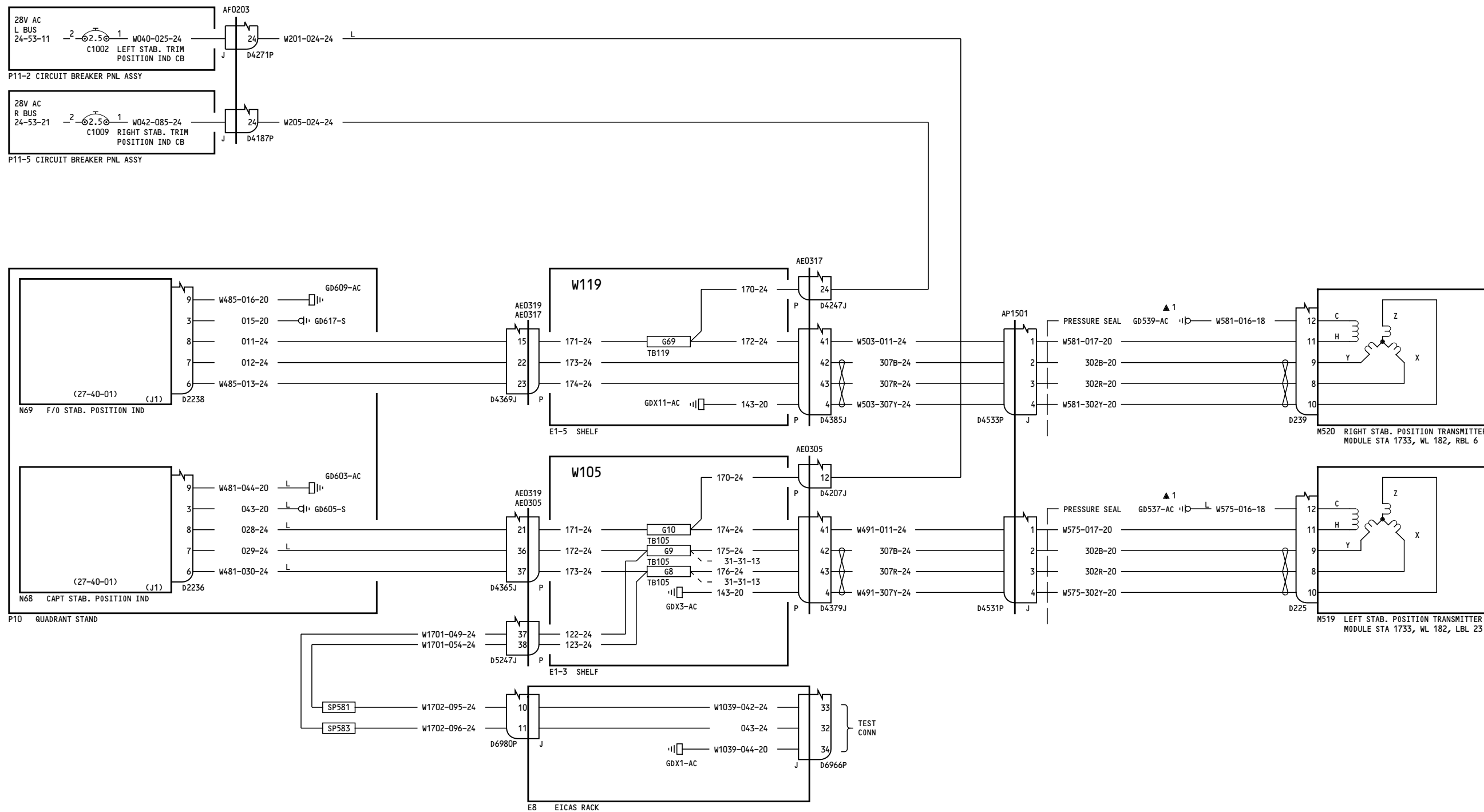

157, 167-199

**STABILIZER TRIM POSITION INDICATOR**

**27-48-11**

Page 4

D280T132

Jan 21/2005

**27-48-11**

Page 4

Jan 21/2005

-A  
21

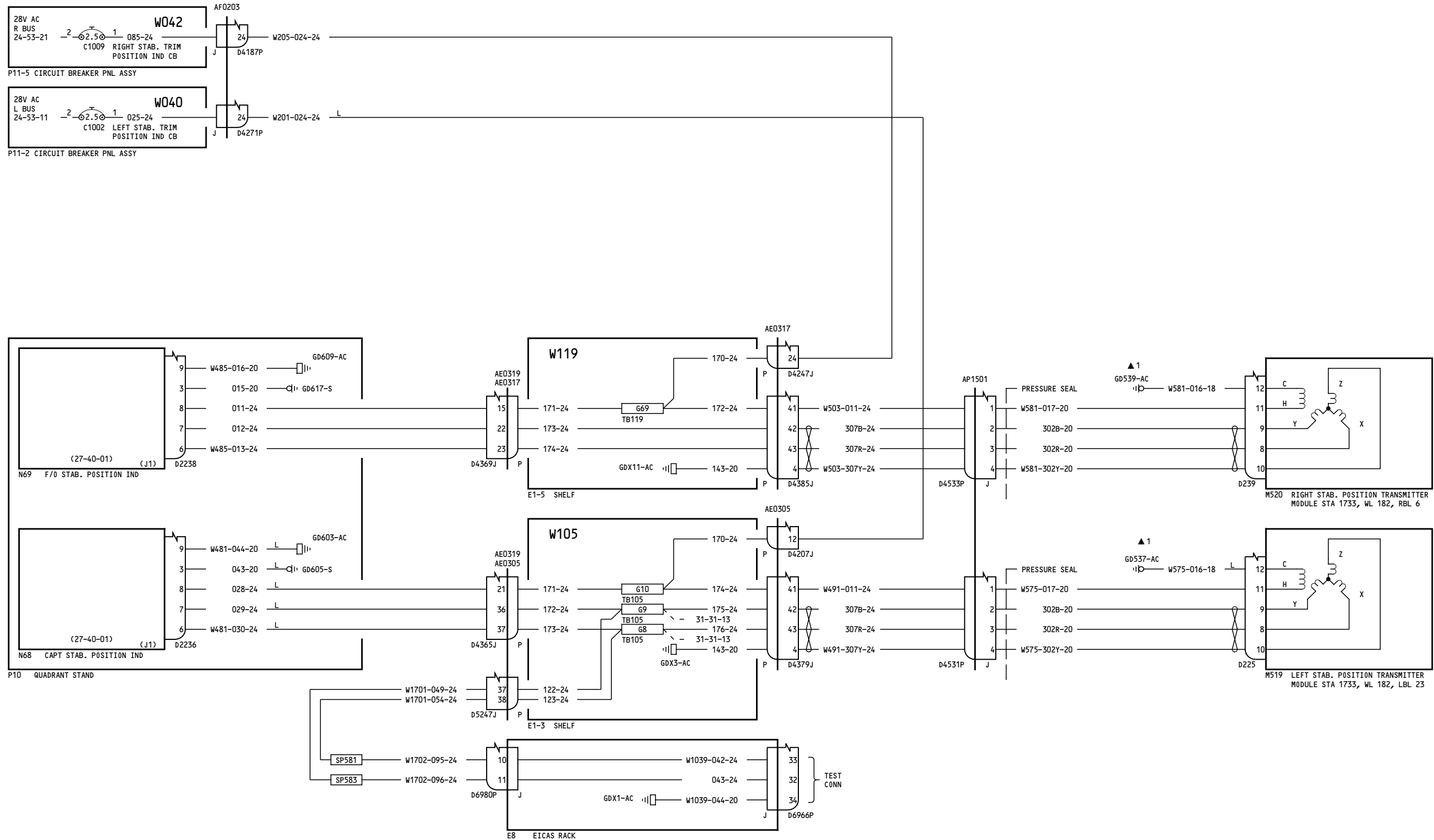

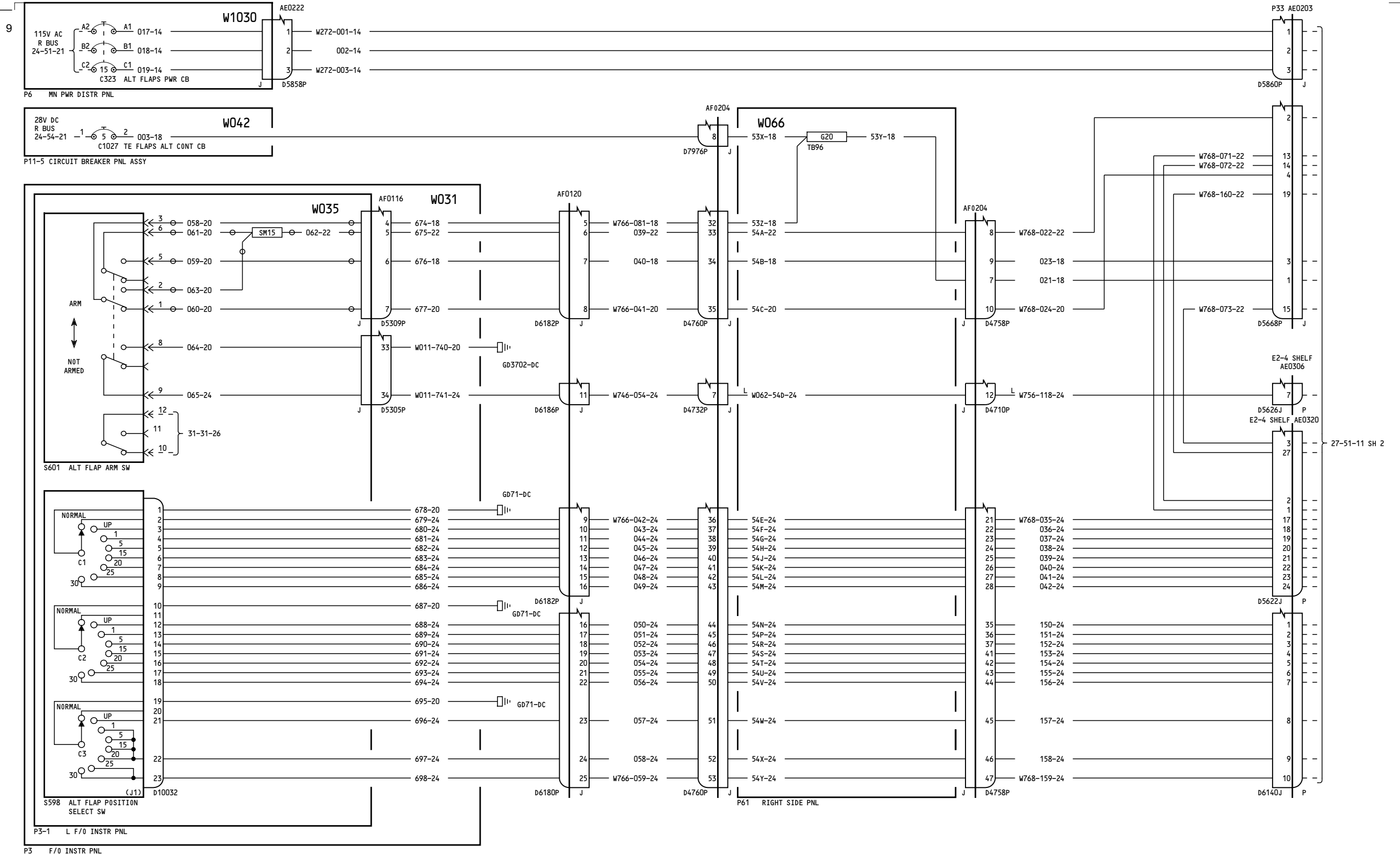

050-280

**ALTERNATE TRAILING EDGE FLAP DRIVE**

**27-51-11**

Page 1.1  
Sheet 1  
Jan 21/2005

D280T132

**27-51-11**

Page 1.1  
Sheet 1  
Jan 21/2005

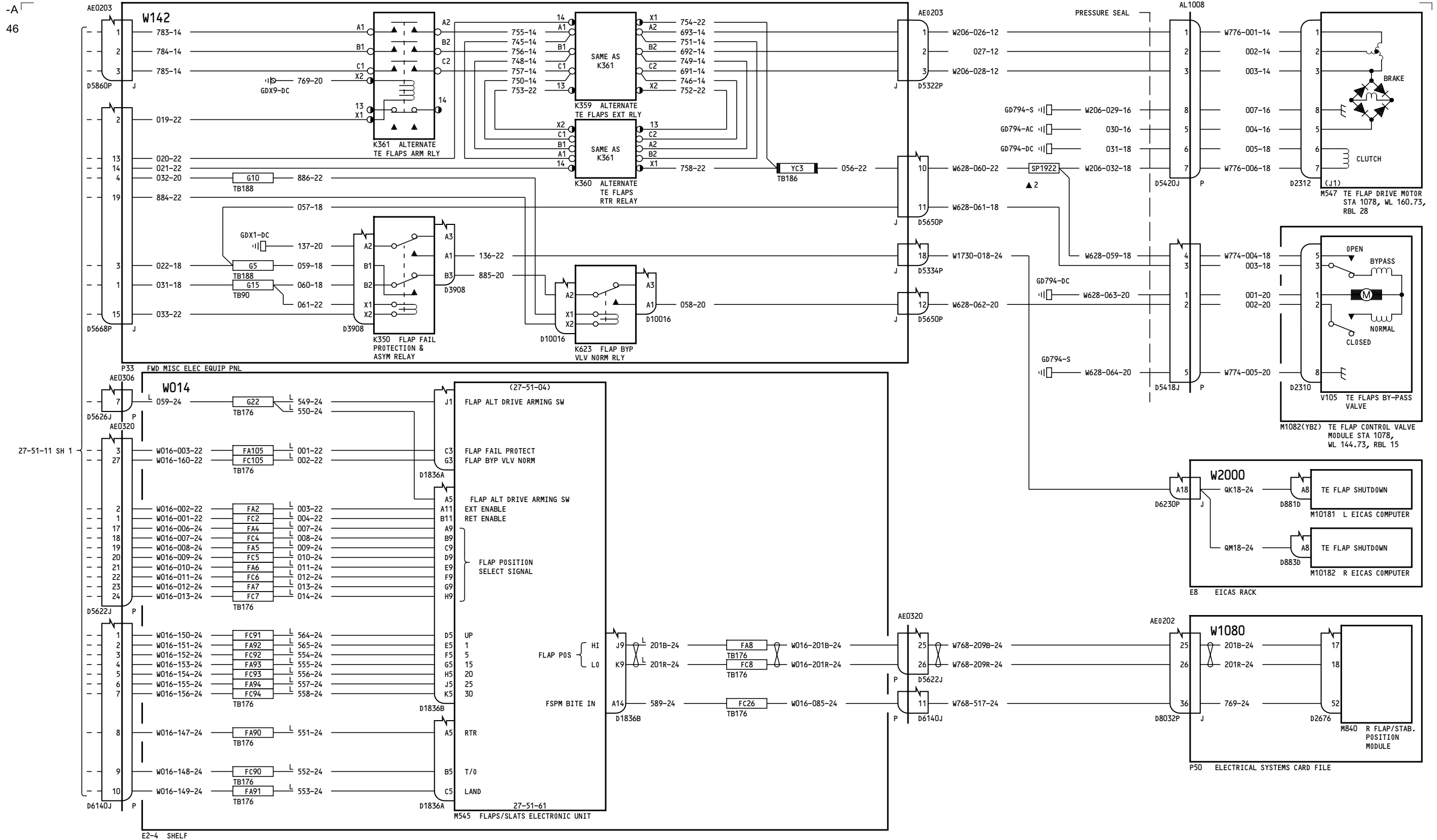

050-280

ALTERNATE TRAILING EDGE FLAP DRIVE

27-51-11

Incorporates 27-0133

27-51-11

D280T132

Page 1.1 Sheet 2 Jan 21/2005

Page 1.1 Sheet 2 Jan 21/2005

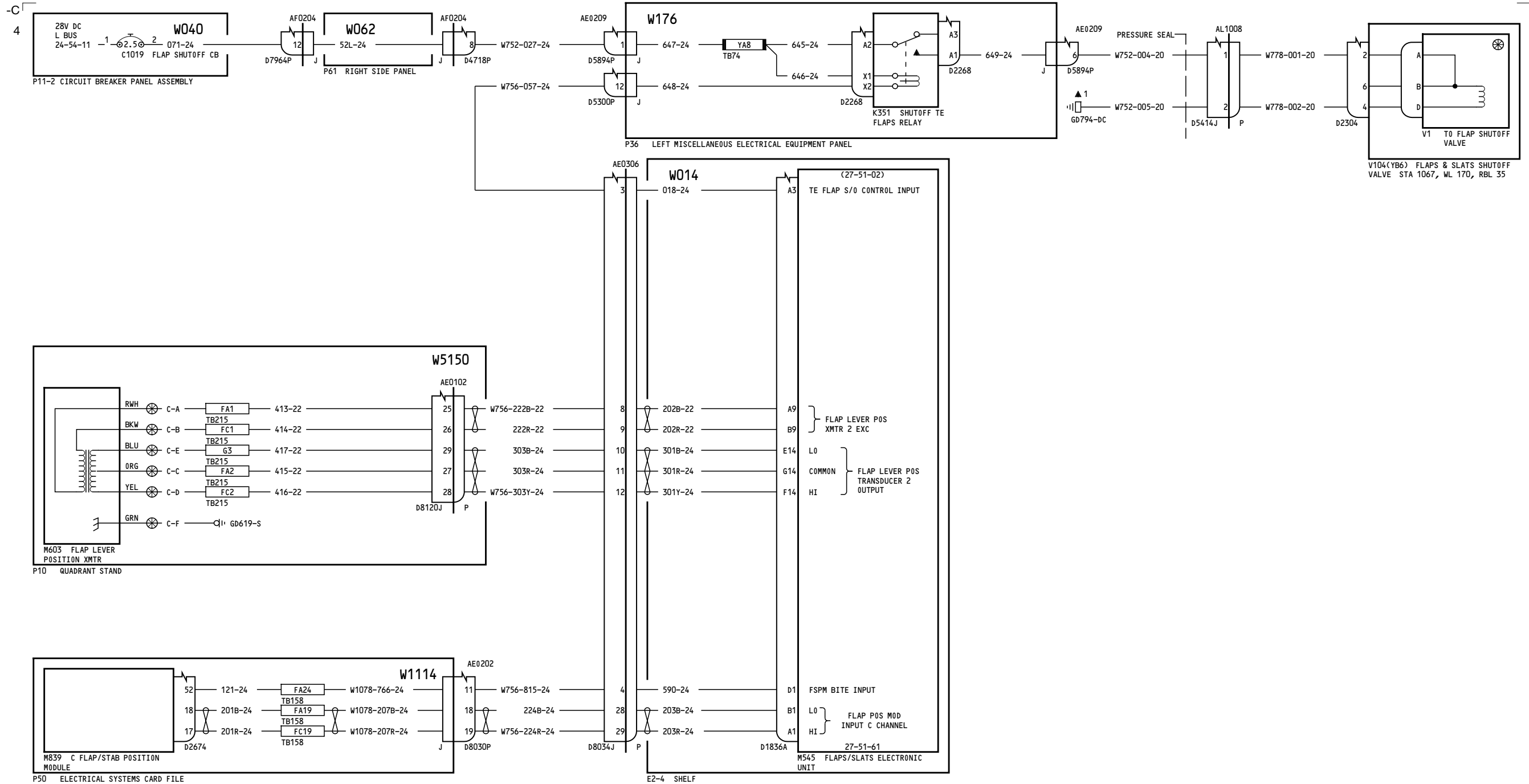

ALL

**TRAILING EDGE FLAP SHUTOFF VALVE**  
D280T132

**27-51-31**  
Page 1  
Jan 21/2005

**27-51-31**  
Page 1  
Jan 21/2005

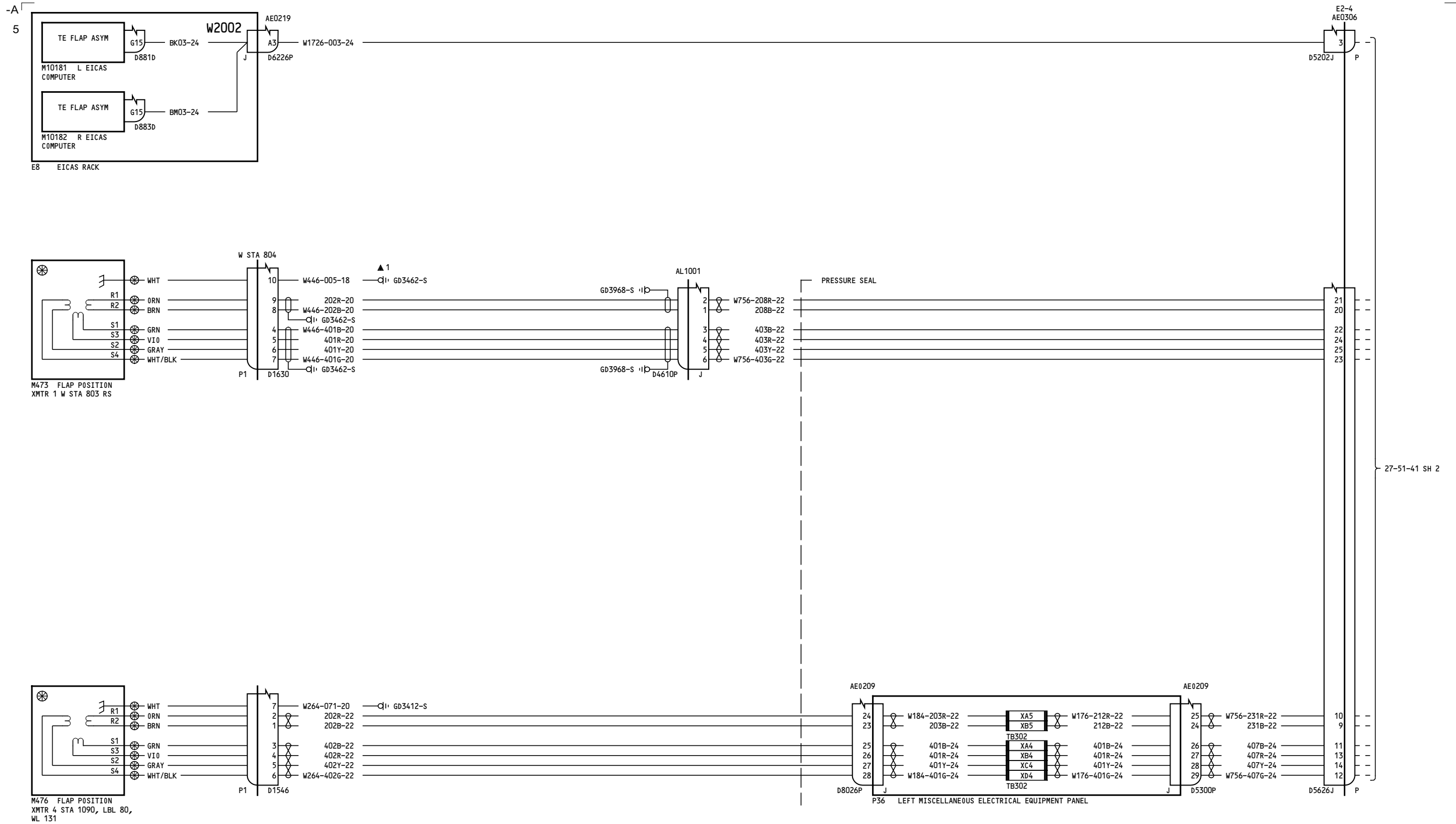

ALL

**TRAILING EDGE FLAP  
ASYMMETRY INDICATION**

**27-51-41**

Page 1  
Sheet 1  
Jan 21/2005

D280T132

**27-51-41**

Page 1  
Sheet 1  
Jan 21/2005



-A  
5

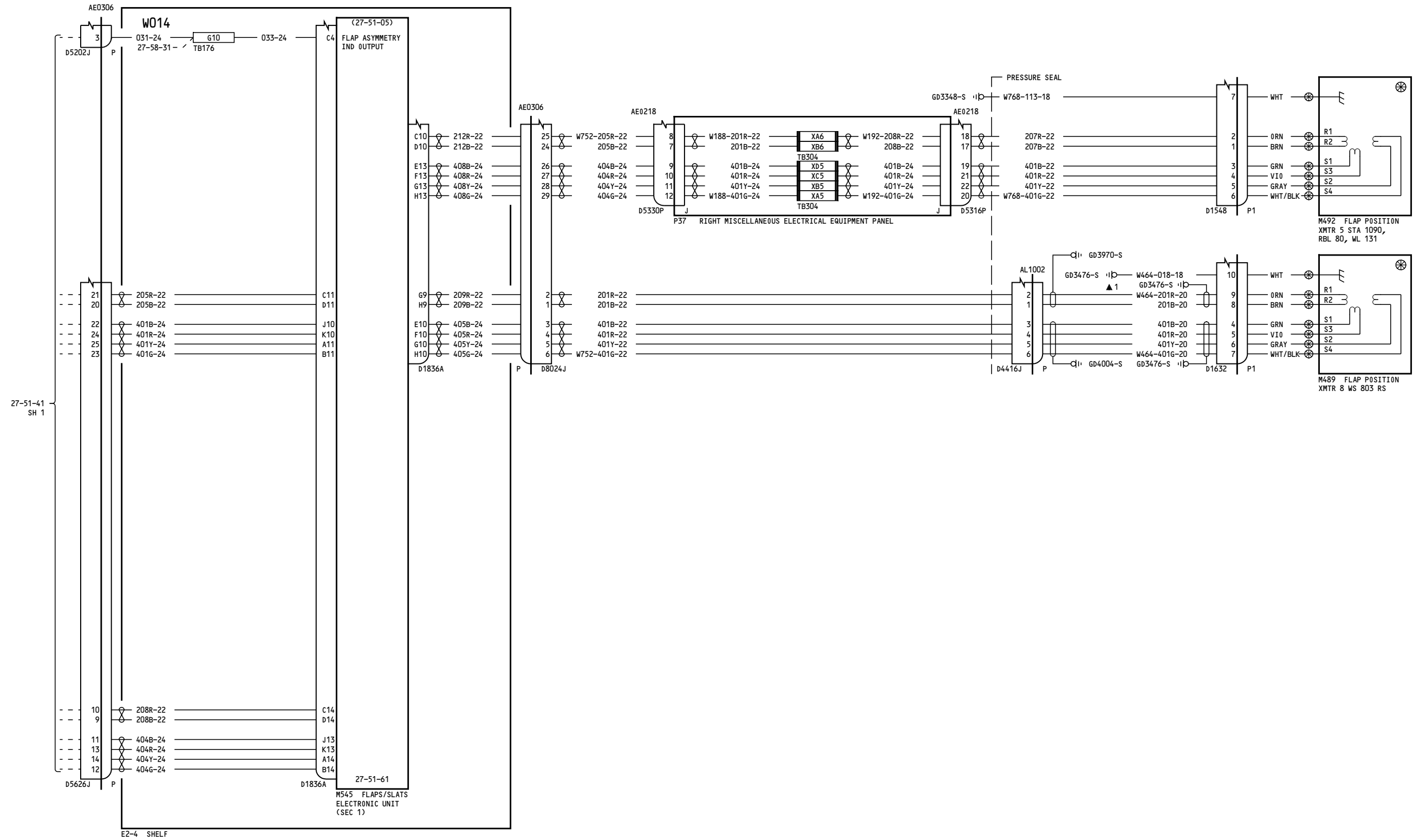

ALL

TRAILING EDGE FLAP ASYMMETRY INDICATION

27-51-41

Page 1  
Sheet 2  
Jan 21/2005

D280T132

27-51-41

Page 1  
Sheet 2  
Jan 21/2005

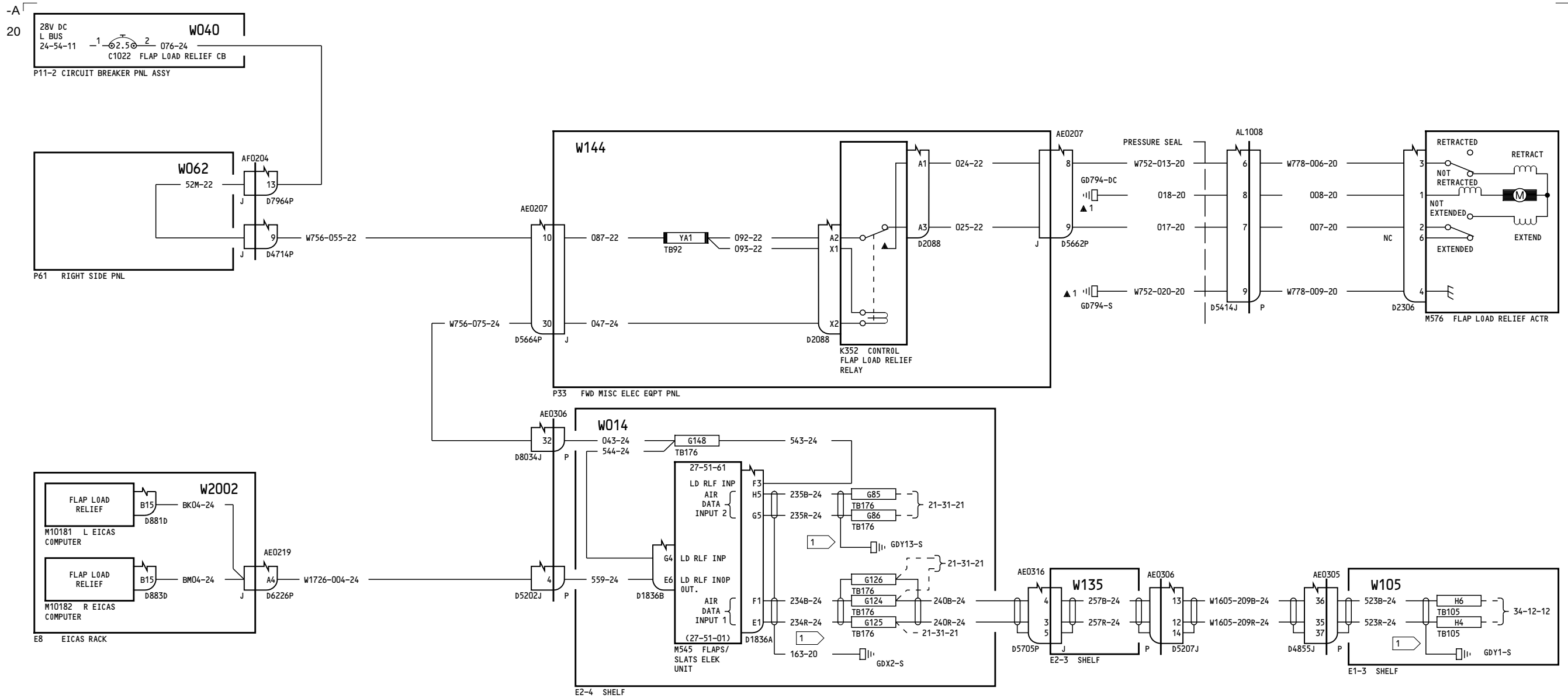

NOTES:  
 1 SHIELD TERMINATION SHALL BE WITHIN 18 INCHES FROM CONNECTOR

050-099

**TRAILING EDGE FLAP  
LOAD RELIEF**

D280T132

**27-51-51**

Page 1

Mar 14/2007

**27-51-51**

Page 1

Mar 14/2007

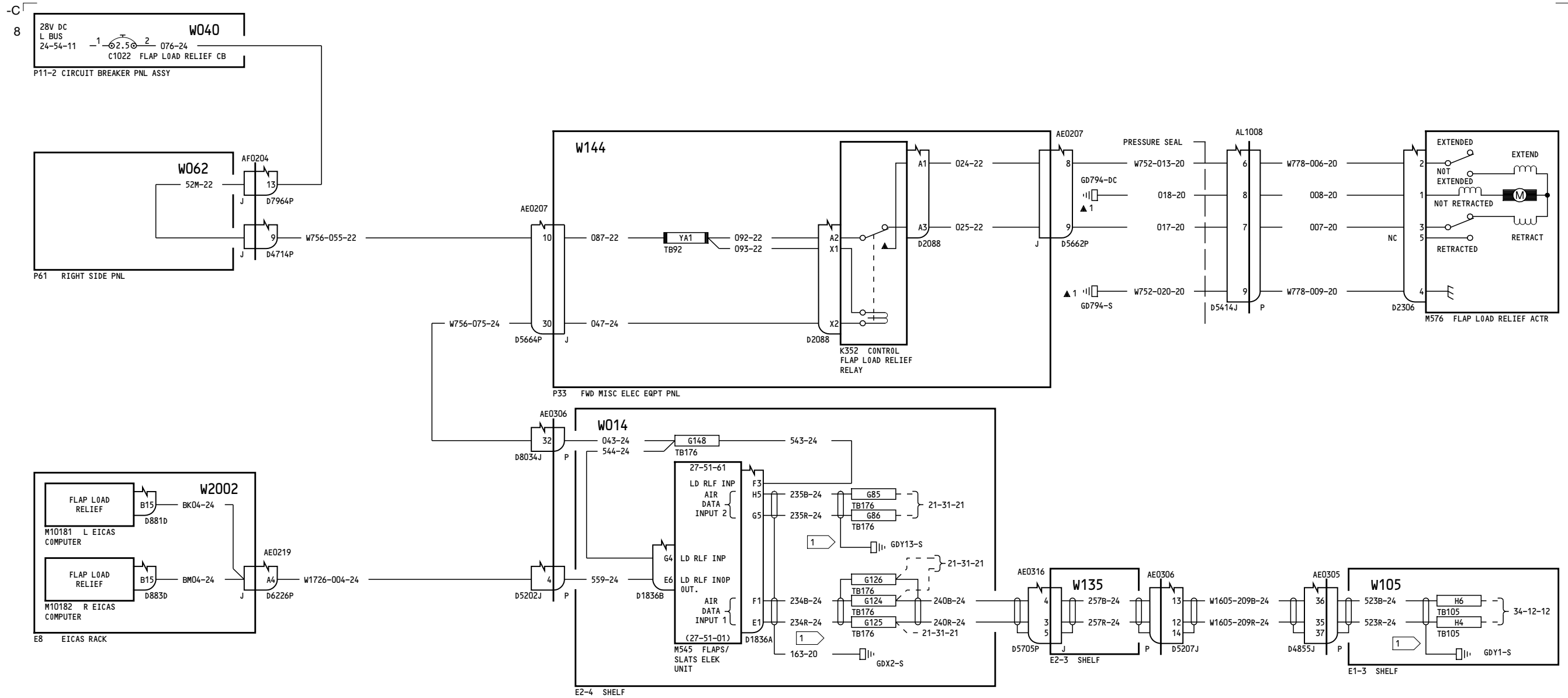

NOTES:  
 1 SHIELD TERMINATION SHALL BE WITHIN 18 INCHES FROM CONNECTOR

150-157, 275-299

**TRAILING EDGE FLAP LOAD RELIEF**

**27-51-51**

Page 2

Mar 14/2007

D280T132

**27-51-51**

Page 2

Mar 14/2007

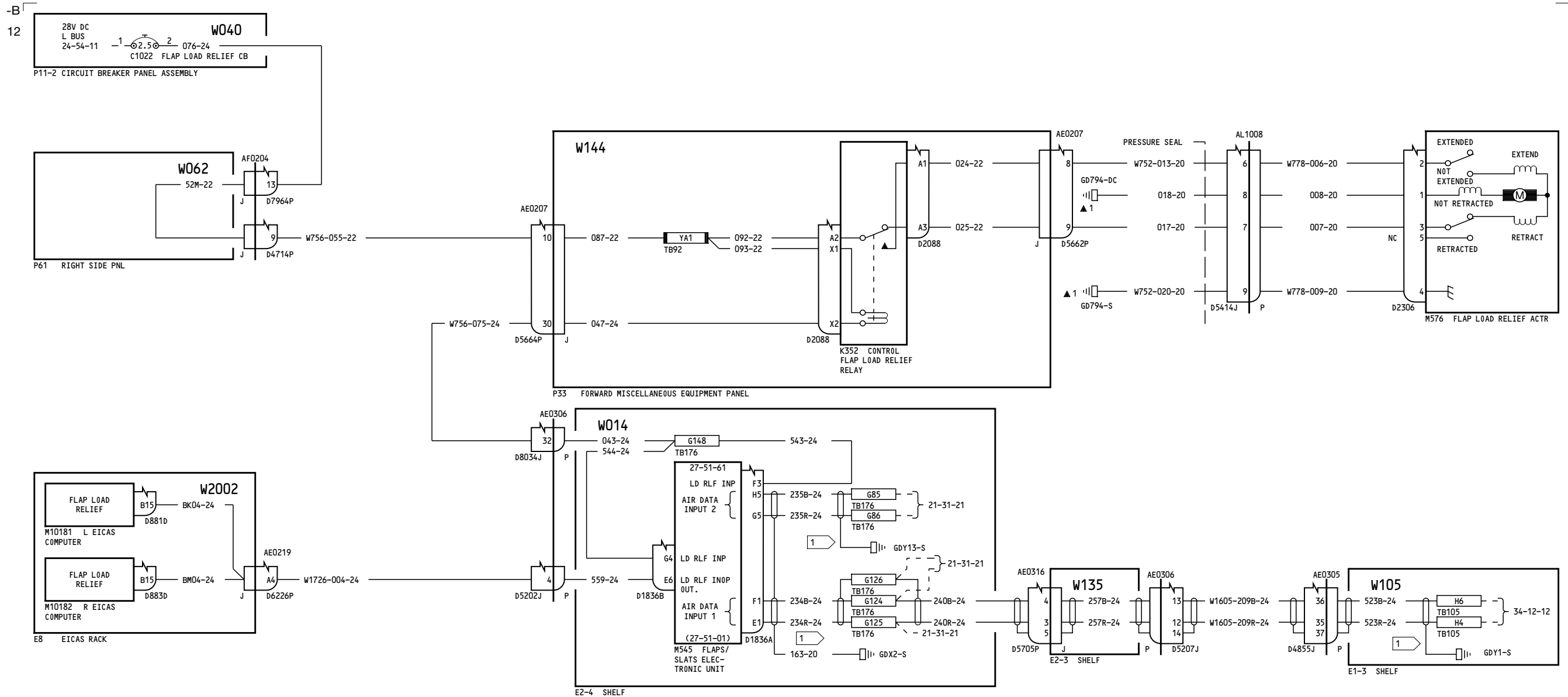

NOTES:  
 1 SHIELD TERMINATION SHALL BE WITHIN 18 INCHES FROM CONNECTOR

162-199	<b>TRAILING EDGE FLAP LOAD RELIEF</b>
	D280T132

**27-51-51**  
 Page 3  
 Mar 14/2007

**27-51-51**  
 Page 3  
 Mar 14/2007

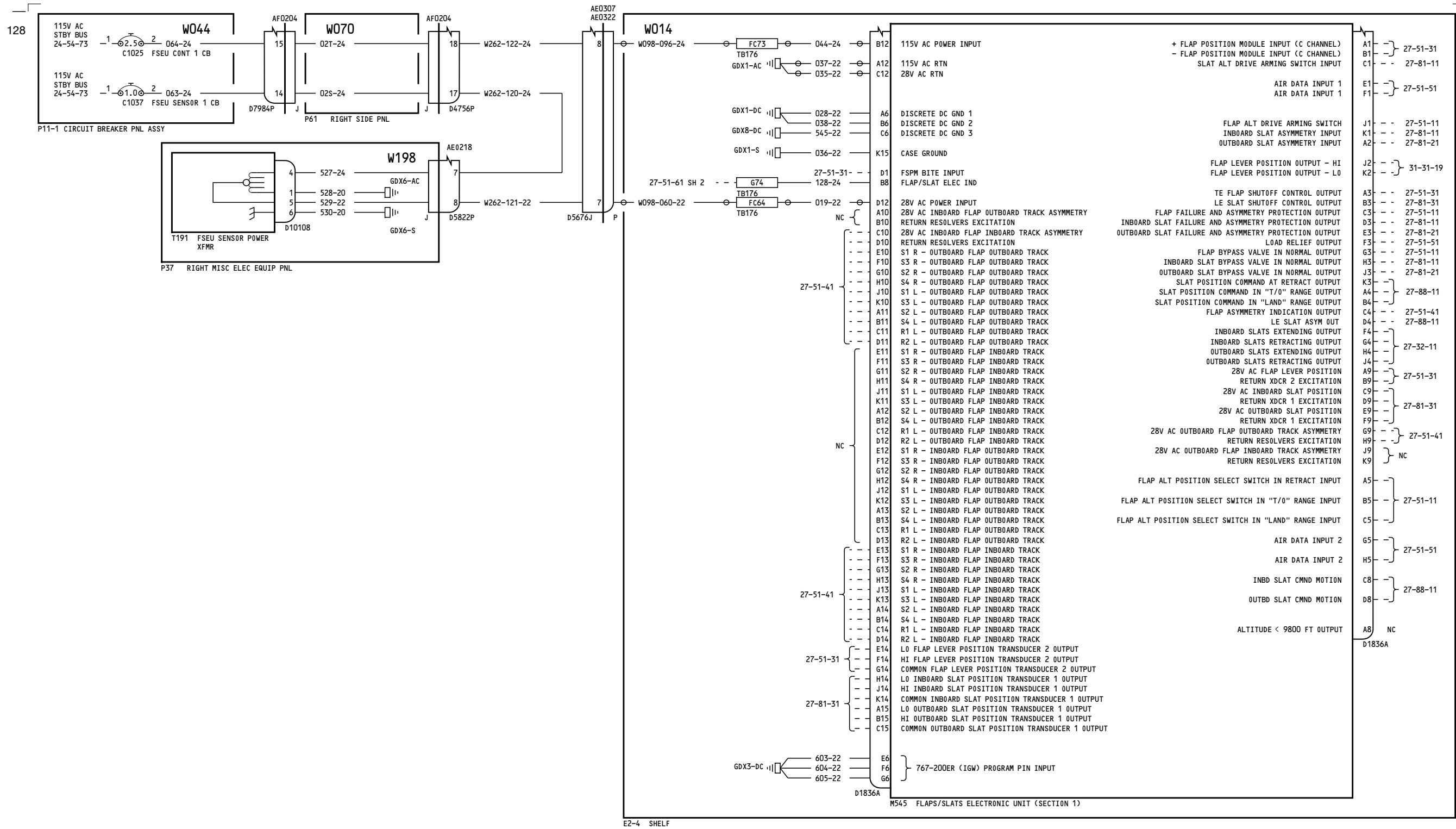

050-051

FLAPS SLATS ELECTRONIC UNIT OUTPUT INTERFACE

D280T132

27-51-61

Page 1.1  
Sheet 1  
Jan 21/2005

Incorporates  
27-0108 R02

27-51-61

Page 1.1  
Sheet 1  
Jan 21/2005

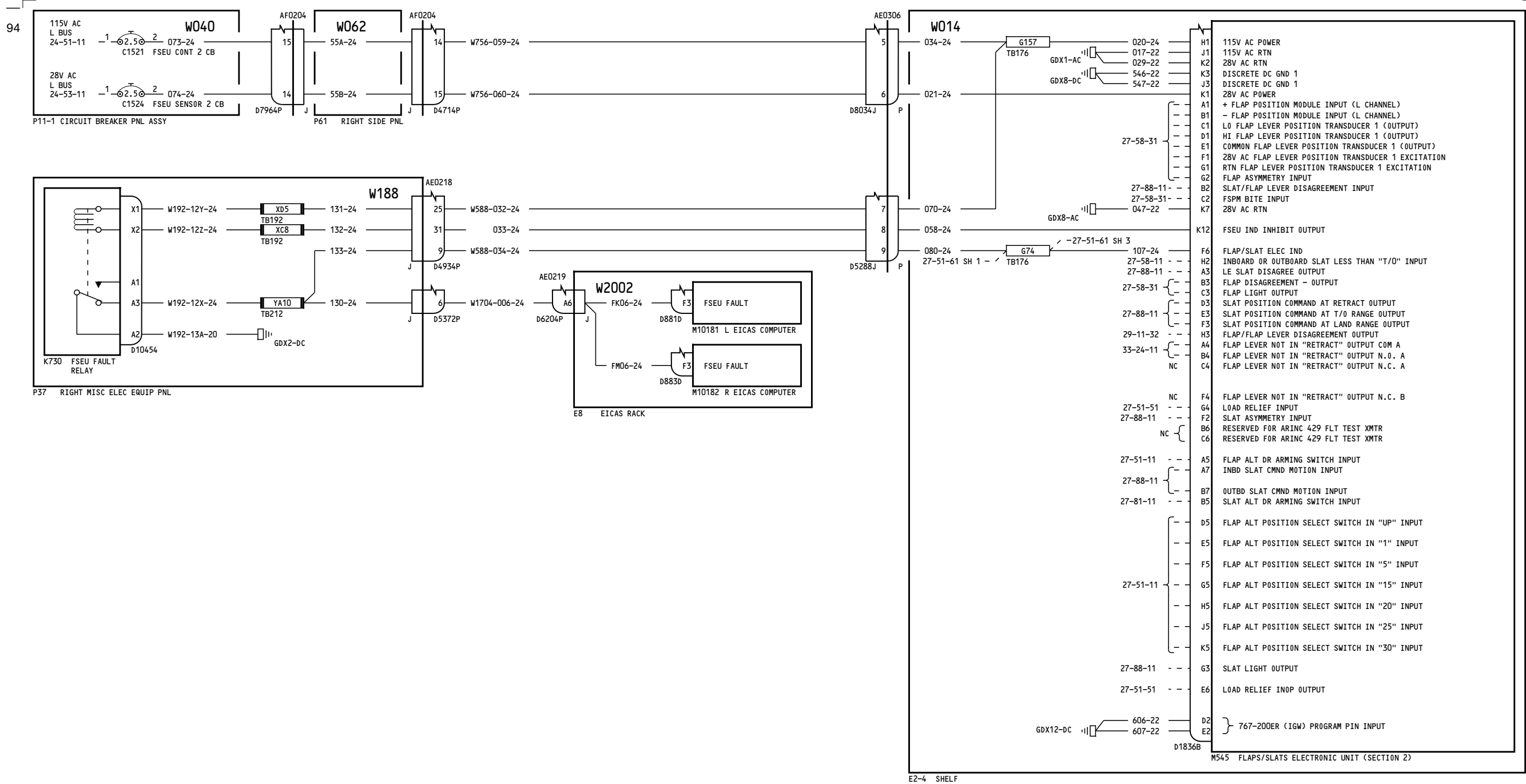

050-051

**FLAPS SLATS ELECTRONIC UNIT OUTPUT INTERFACE**

**27-51-61**

Page 1.1  
Sheet 2  
Jan 21/2005

D280T132

**27-51-61**

Page 1.1  
Sheet 2  
Jan 21/2005

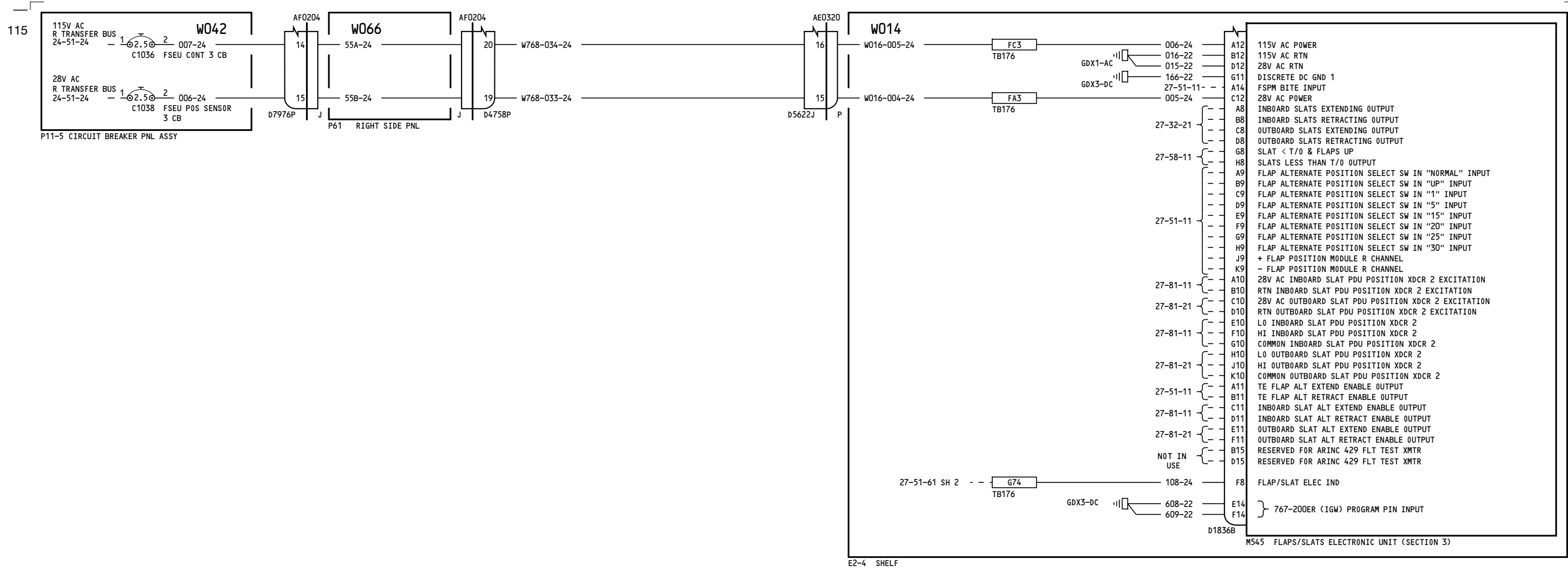

050-051

**FLAPS SLATS ELECTRONIC UNIT OUTPUT INTERFACE**

**27-51-61**

Page 1.1  
Sheet 3  
Jan 21/2005

D280T132

**27-51-61**

Page 1.1  
Sheet 3  
Jan 21/2005

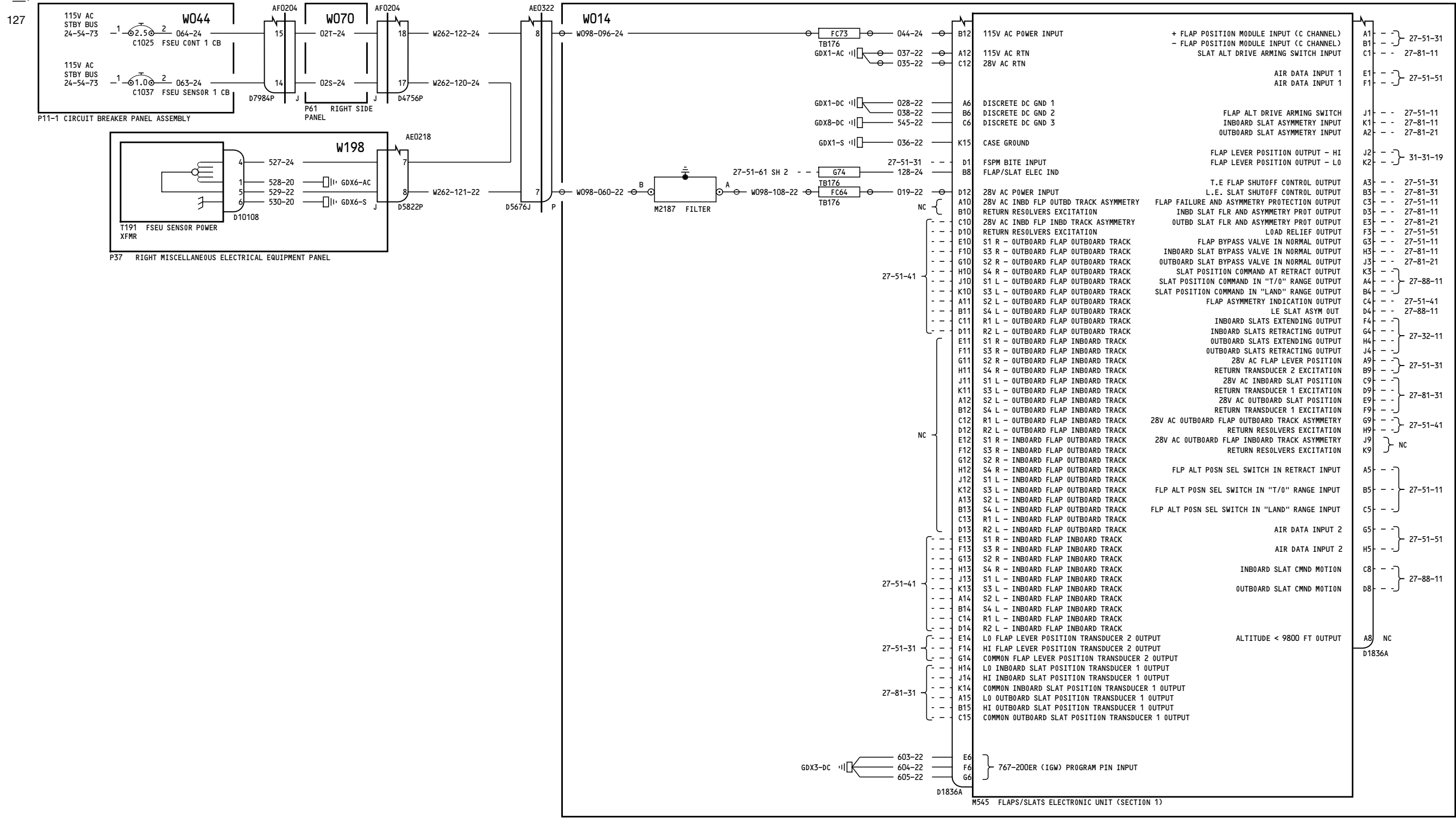

E2-4 SHELF

050-051

**FLAPS SLATS ELECTRONIC UNIT OUTPUT INTERFACE**

**27-51-61**

Page 1.2  
Sheet 1  
Jan 21/2005

D280T132

Incorporates  
27-0108 R02  
27-0131

**27-51-61**

Page 1.2  
Sheet 1  
Jan 21/2005



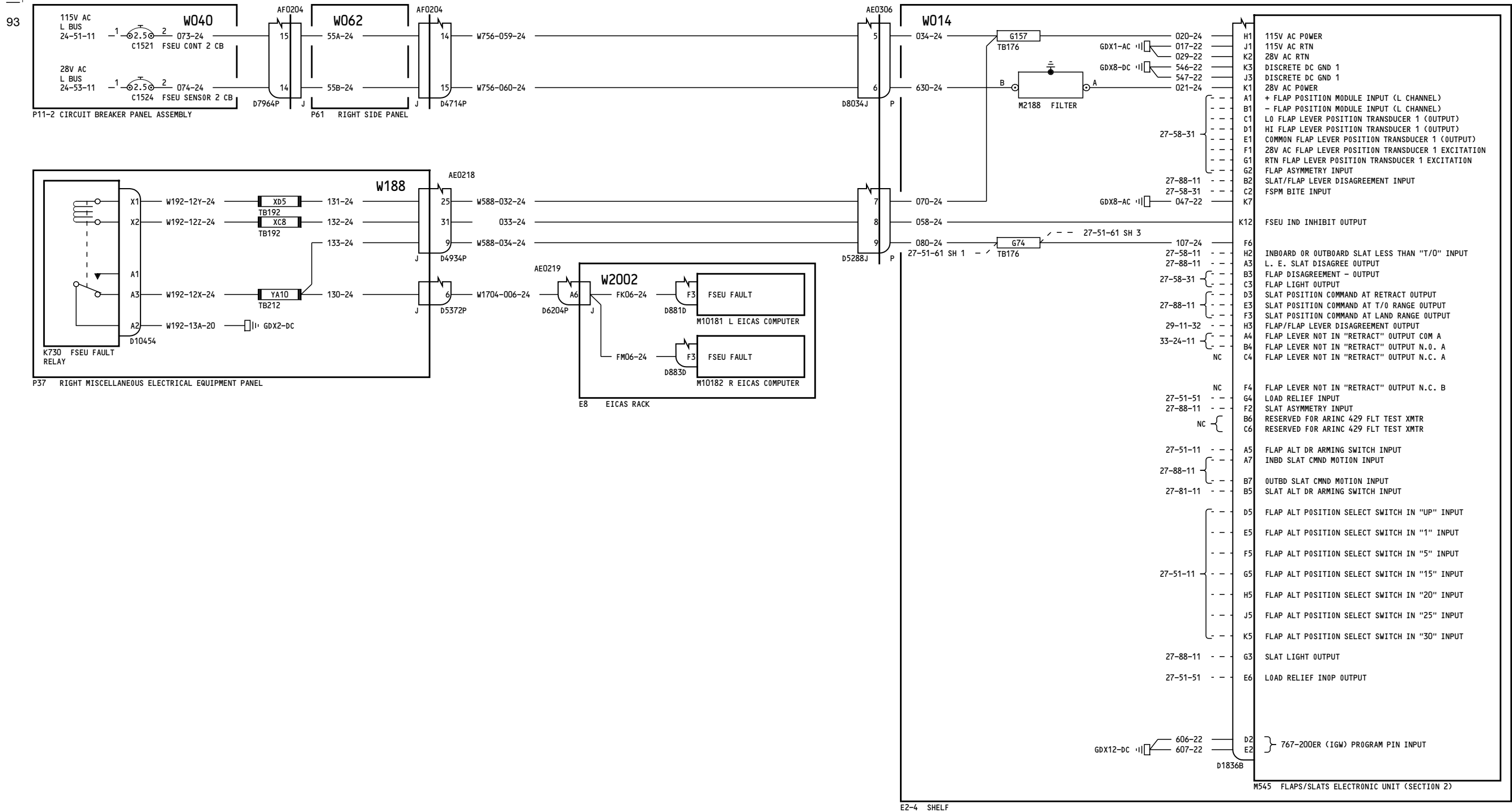

050-051

**FLAPS SLATS ELECTRONIC UNIT OUTPUT INTERFACE**

**27-51-61**

Page 1.2  
Sheet 2  
Jan 21/2005

D280T132

Incorporates  
27-0131

**27-51-61**

Page 1.2  
Sheet 2  
Jan 21/2005

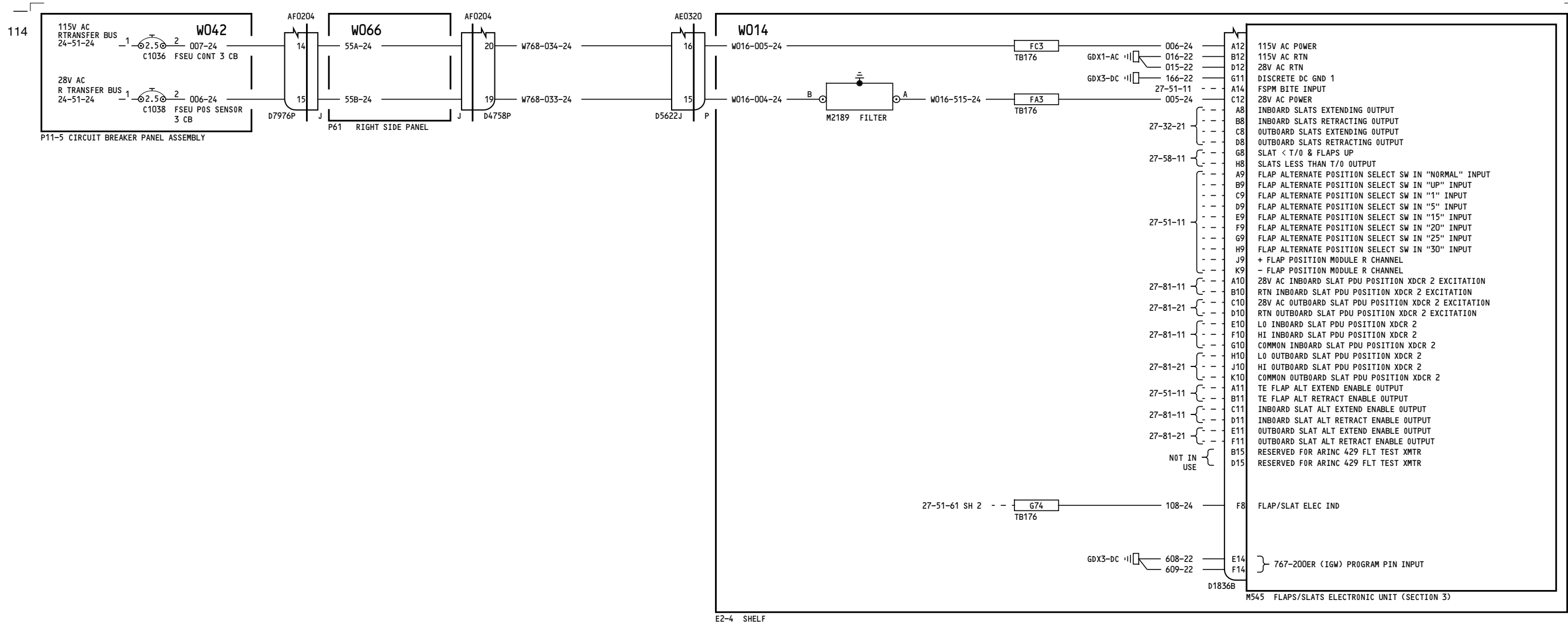

050-051

**FLAPS SLATS ELECTRONIC UNIT OUTPUT INTERFACE**

**27-51-61**

Page 1.2  
Sheet 3  
Jan 21/2005

D280T132

Incorporates  
▶ 27-0131

**27-51-61**

Page 1.2  
Sheet 3  
Jan 21/2005

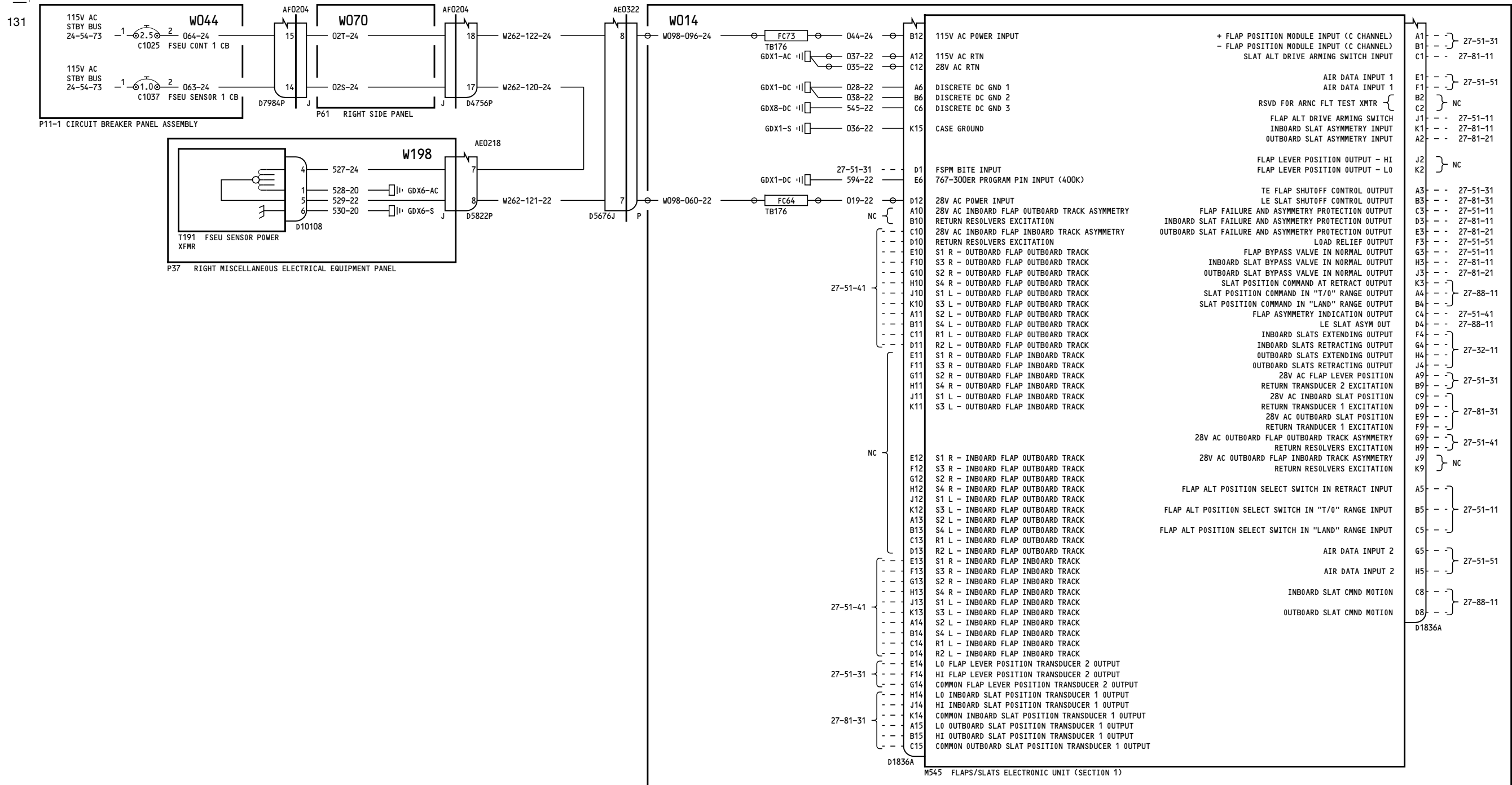

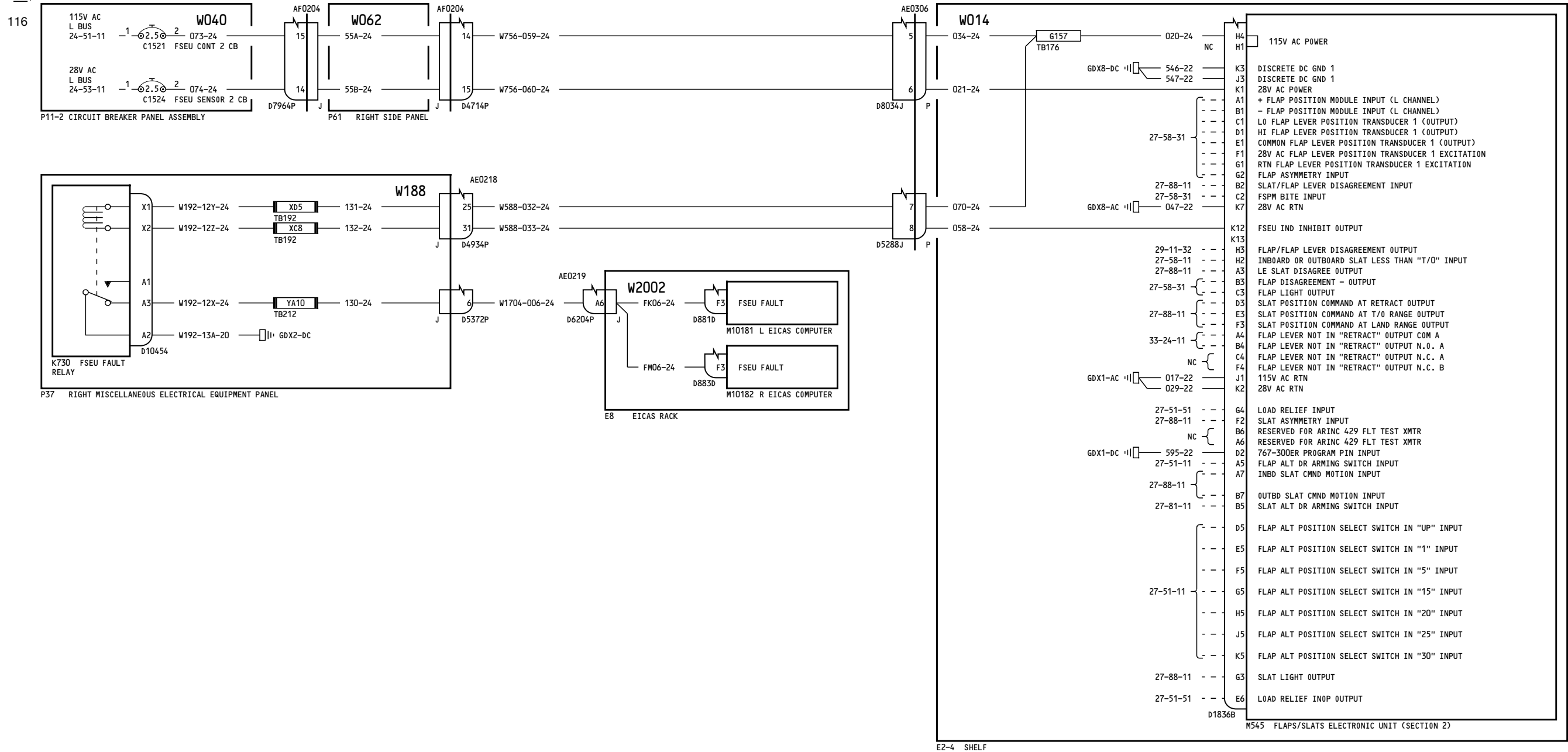

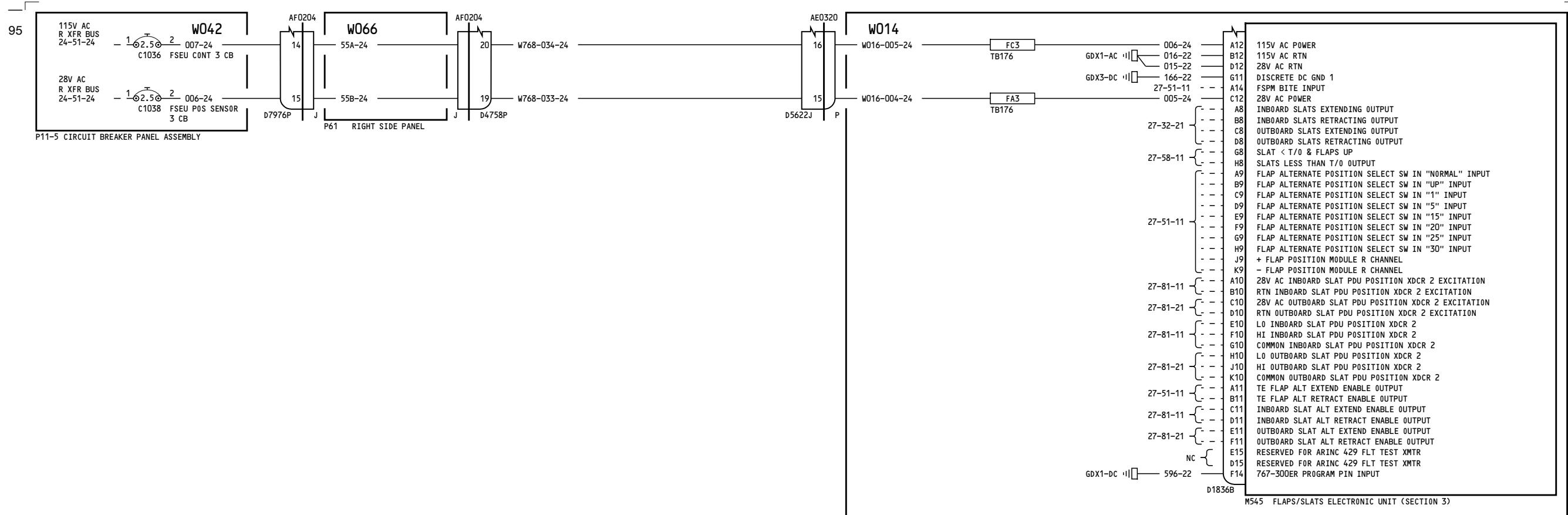

150-166

**FLAPS SLATS ELECTRONIC UNIT OUTPUT INTERFACE**

**27-51-61**

Page 2.1  
 Sheet 3  
 Jan 21/2005

D280T132

**27-51-61**

Page 2.1  
 Sheet 3  
 Jan 21/2005

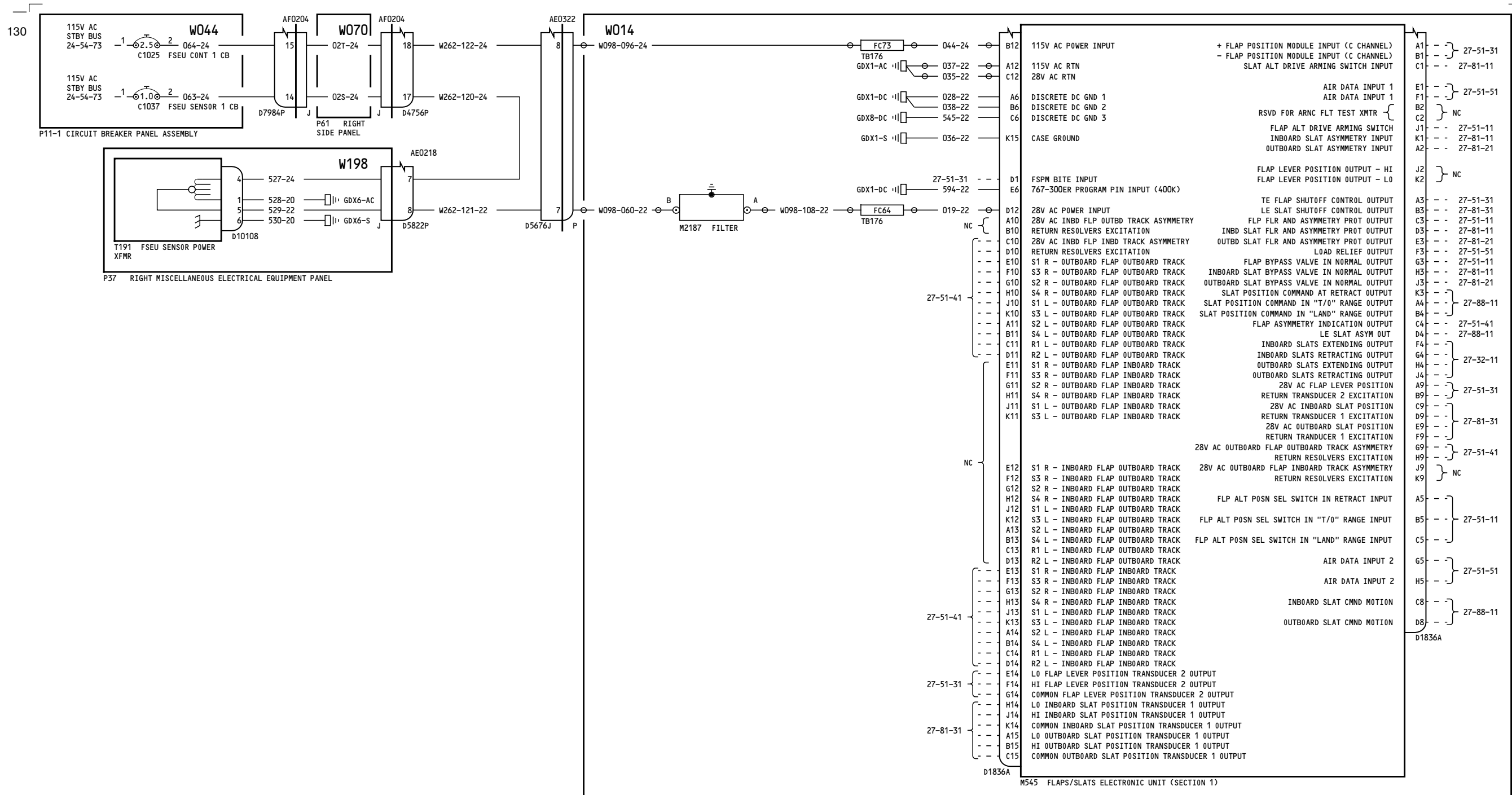

E2-4 SHELF

150-166

**FLAPS SLATS ELECTRONIC UNIT OUTPUT INTERFACE**

**27-51-61**

Page 2.2  
Sheet 1  
Jan 21/2005

D280T132

Incorporates  
27-0108 R02  
27-0131

**27-51-61**

Page 2.2  
Sheet 1  
Jan 21/2005

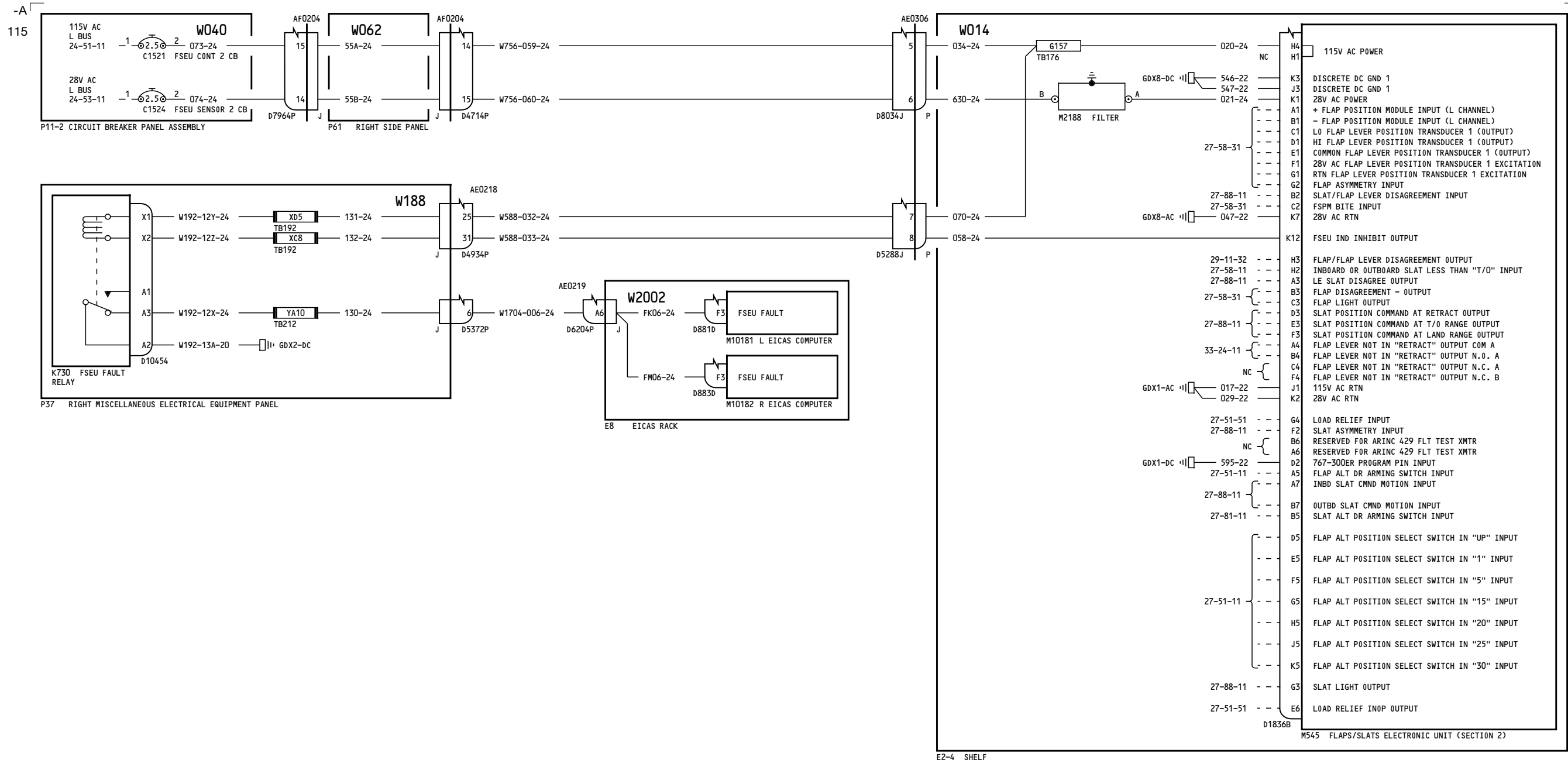

150-166

**FLAPS SLATS ELECTRONIC UNIT OUTPUT INTERFACE**

**27-51-61**

Page 2.2  
Sheet 2  
Jun 06/2008

D280T132

Incorporates  
27-0131

**27-51-61**

Page 2.2  
Sheet 2  
Jun 06/2008

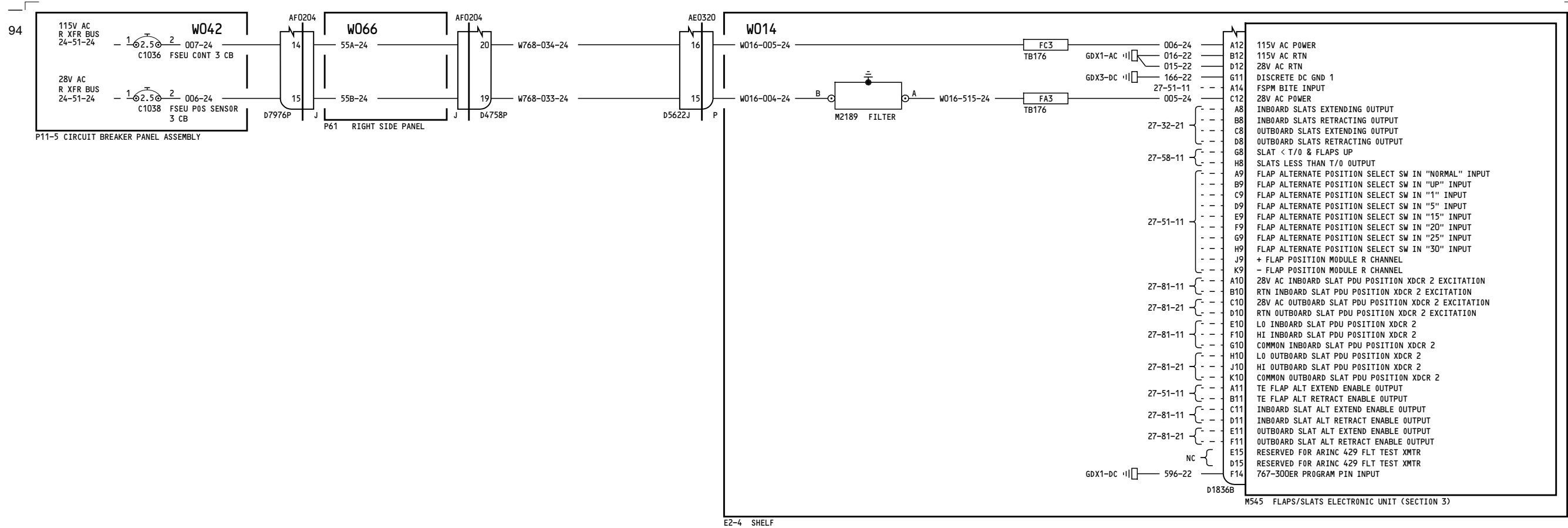

150-166

**FLAPS SLATS ELECTRONIC UNIT OUTPUT INTERFACE**

D280T132

**27-51-61**

Page 2.2  
Sheet 3  
Jan 21/2005

Incorporates  
▶ 27-0131

**27-51-61**

Page 2.2  
Sheet 3  
Jan 21/2005



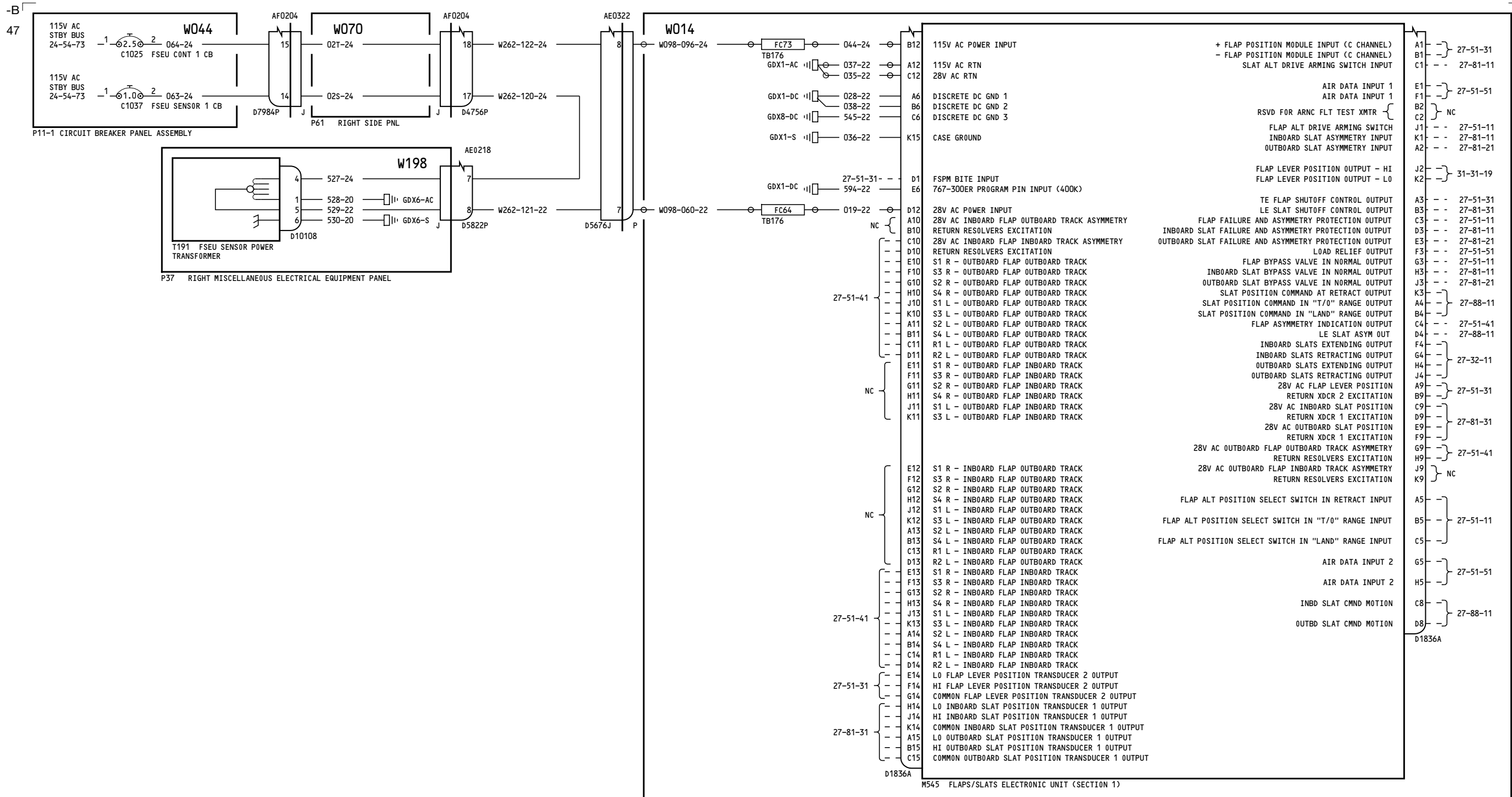

E2-4 SHELF

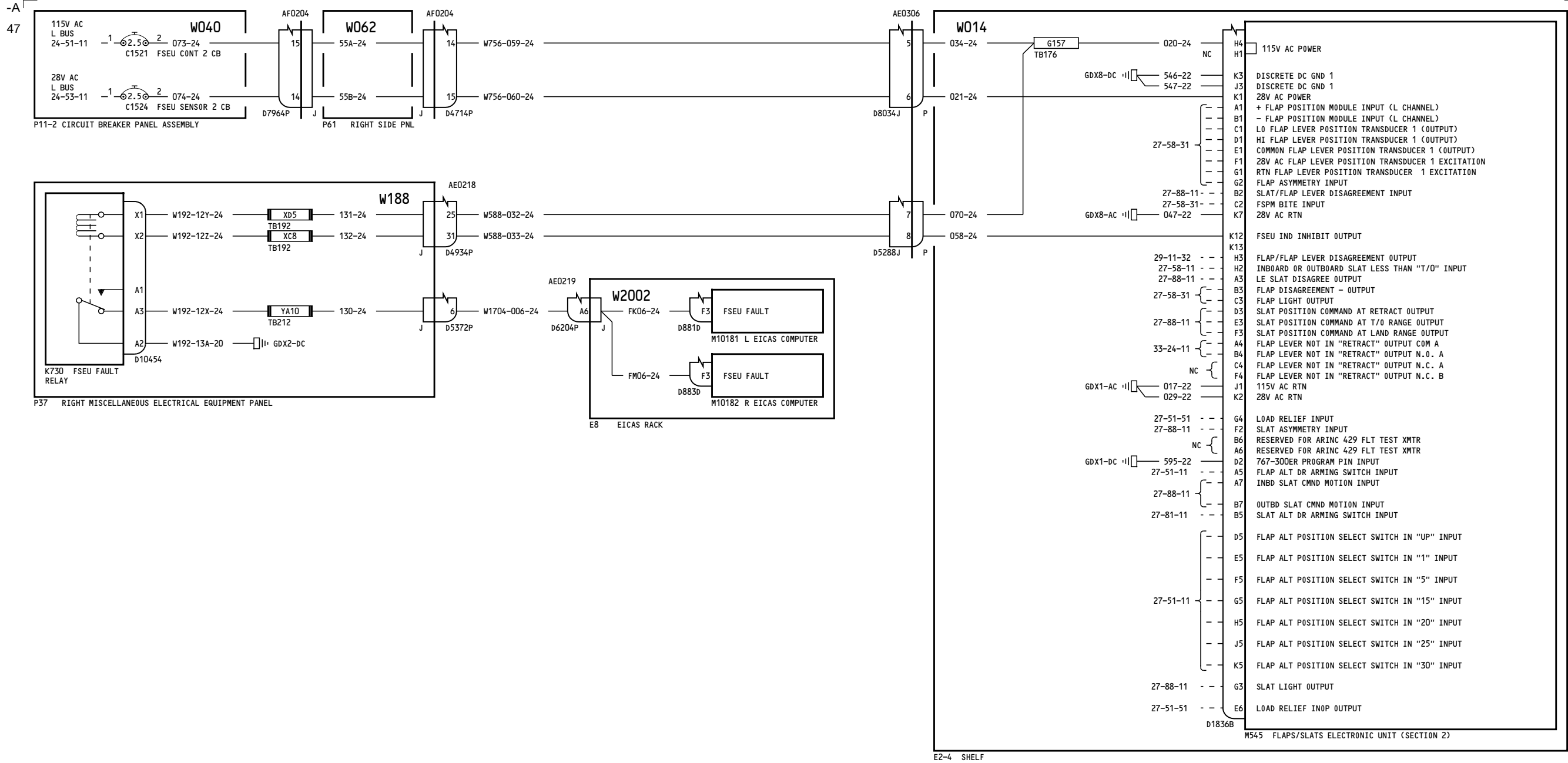

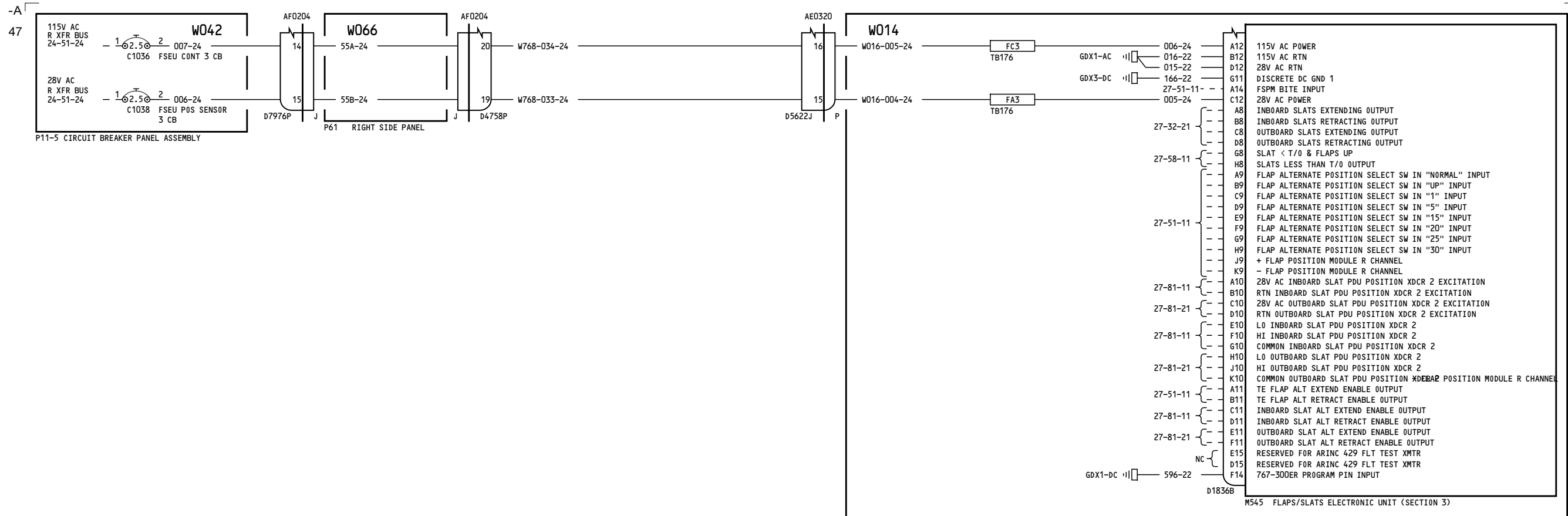

167-199, 280-299

**FLAPS SLATS ELECTRONIC UNIT OUTPUT INTERFACE**

**27-51-61**

Page 3  
Sheet 3  
Jan 21/2005

D280T132

**27-51-61**

Page 3  
Sheet 3  
Jan 21/2005

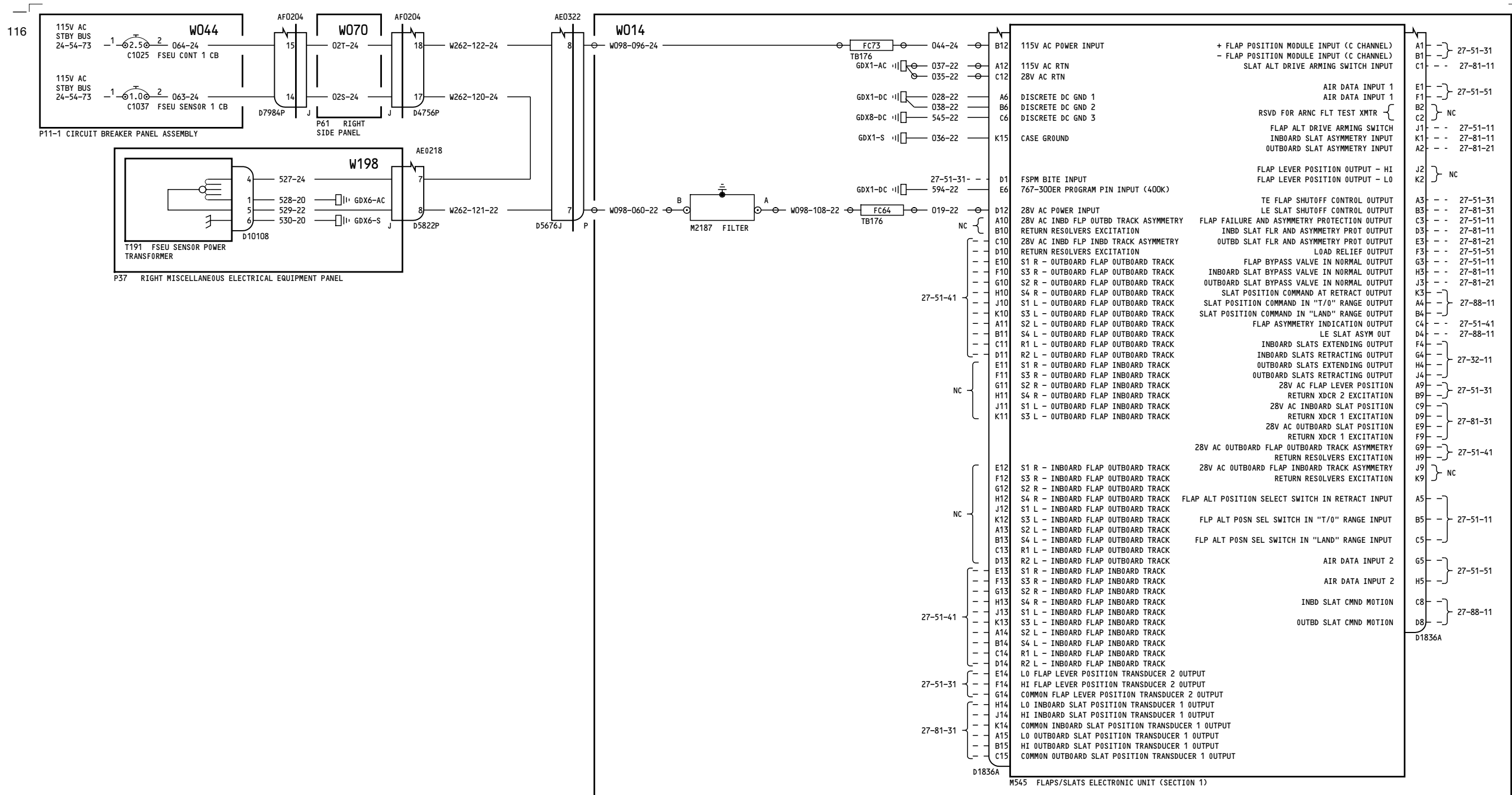

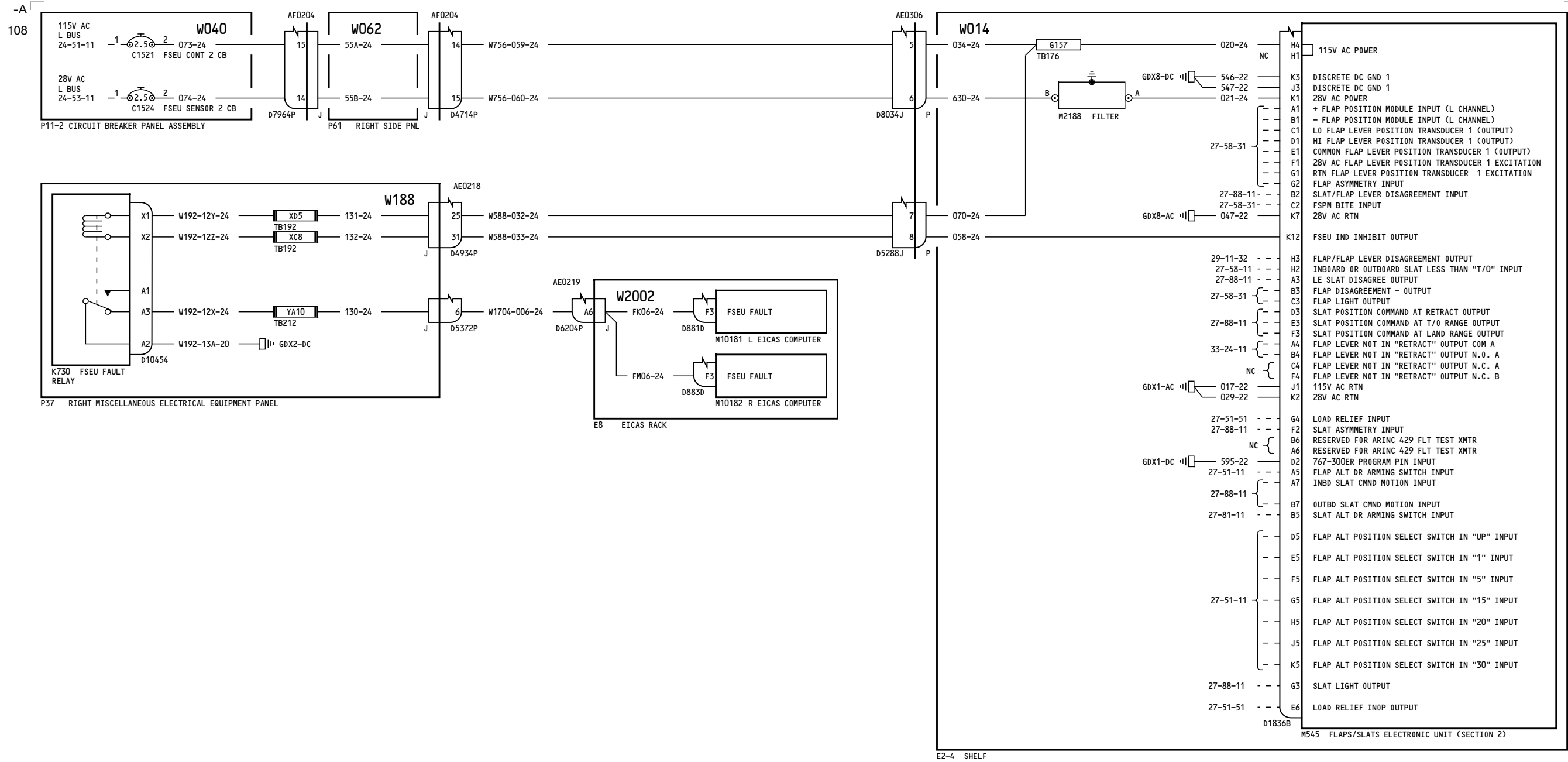

167, 280

**FLAPS SLATS ELECTRONIC UNIT OUTPUT INTERFACE**

**27-51-61**

Page 3.1  
Sheet 2  
Jun 06/2008

D280T132

Incorporates  
27-0131

**27-51-61**

Page 3.1  
Sheet 2  
Jun 06/2008

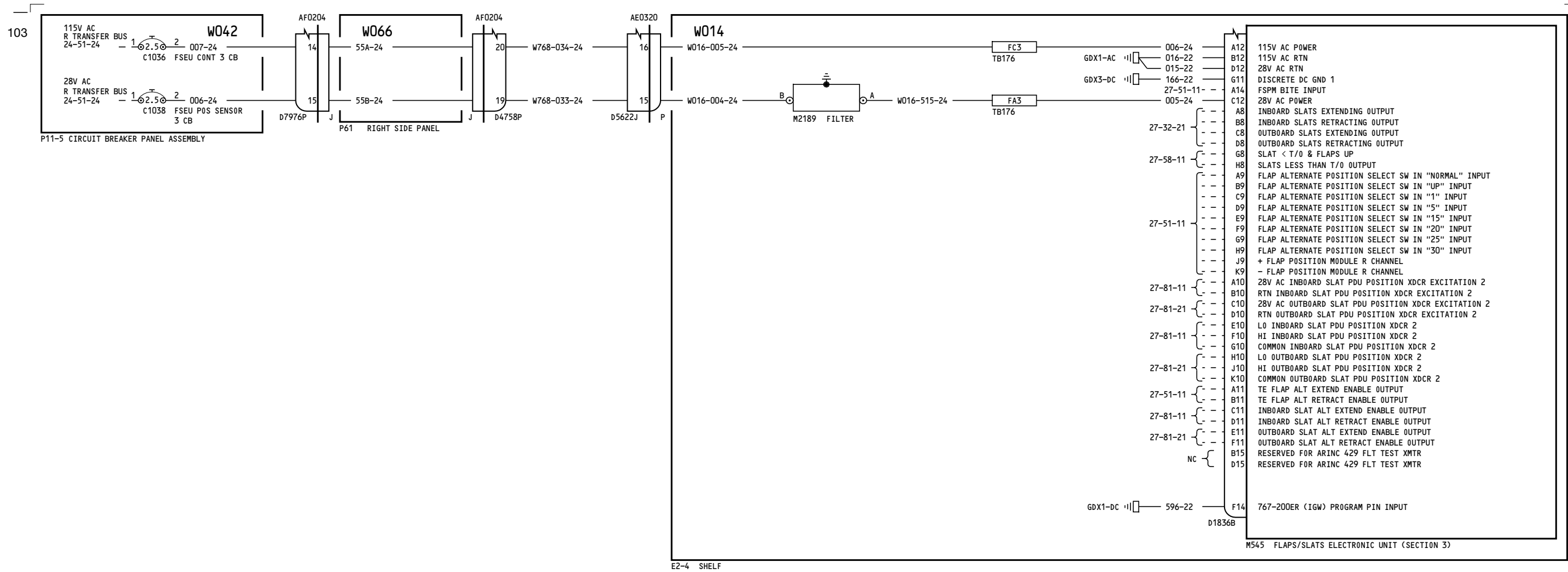

167, 280

**FLAPS SLATS ELECTRONIC UNIT OUTPUT INTERFACE**

**27-51-61**

Page 3.1  
Sheet 3  
Jan 21/2005

D280T132

Incorporates  
27-0131

**27-51-61**

Page 3.1  
Sheet 3  
Jan 21/2005

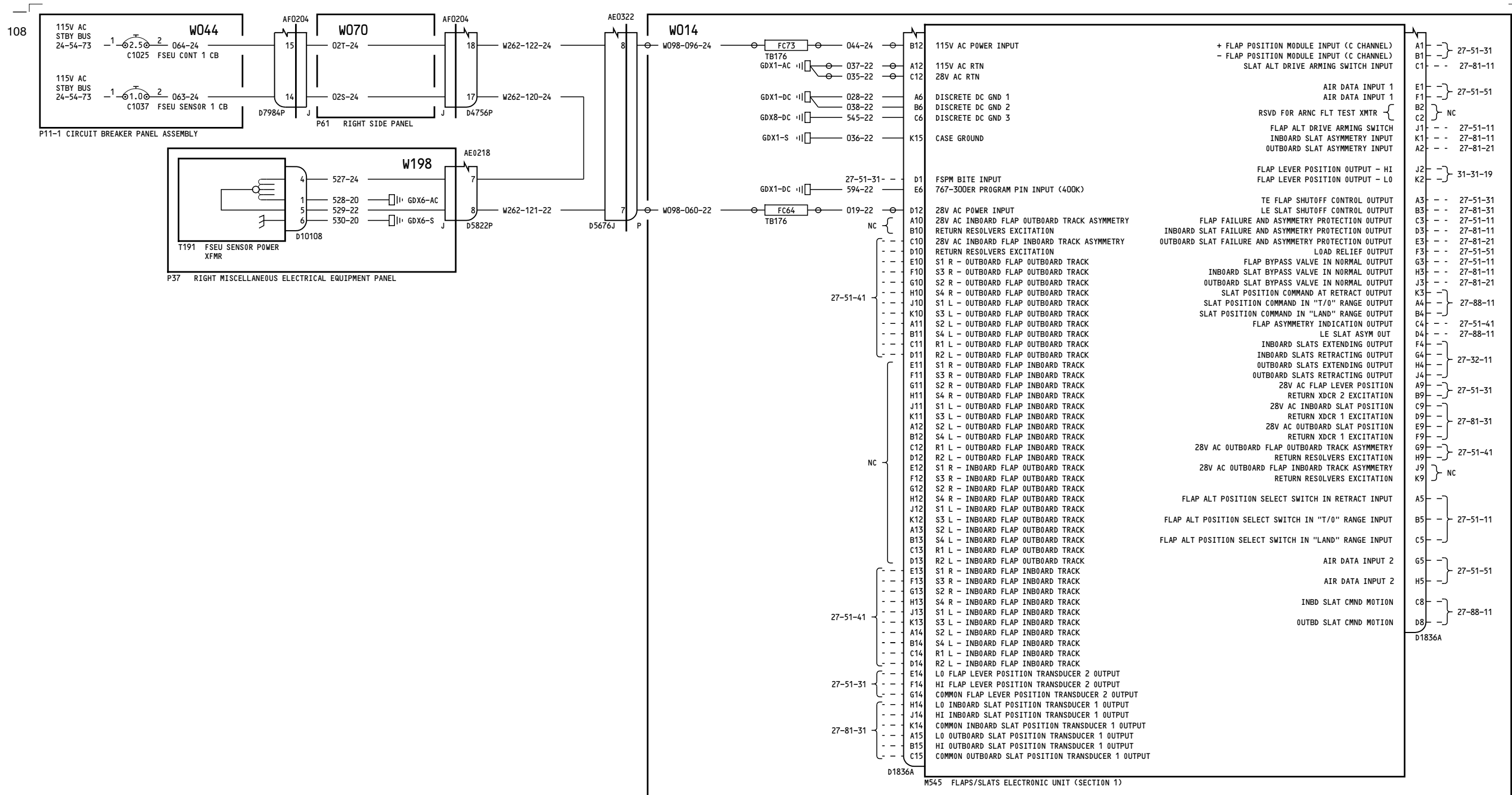

E2-4 SHELF

275-276

**FLAPS SLATS ELECTRONIC UNIT OUTPUT INTERFACE**

D280T132

**27-51-61**

Page 4.1  
Sheet 1  
Jan 21/2005

Incorporates  
27-0108 R02

**27-51-61**

Page 4.1  
Sheet 1  
Jan 21/2005

113

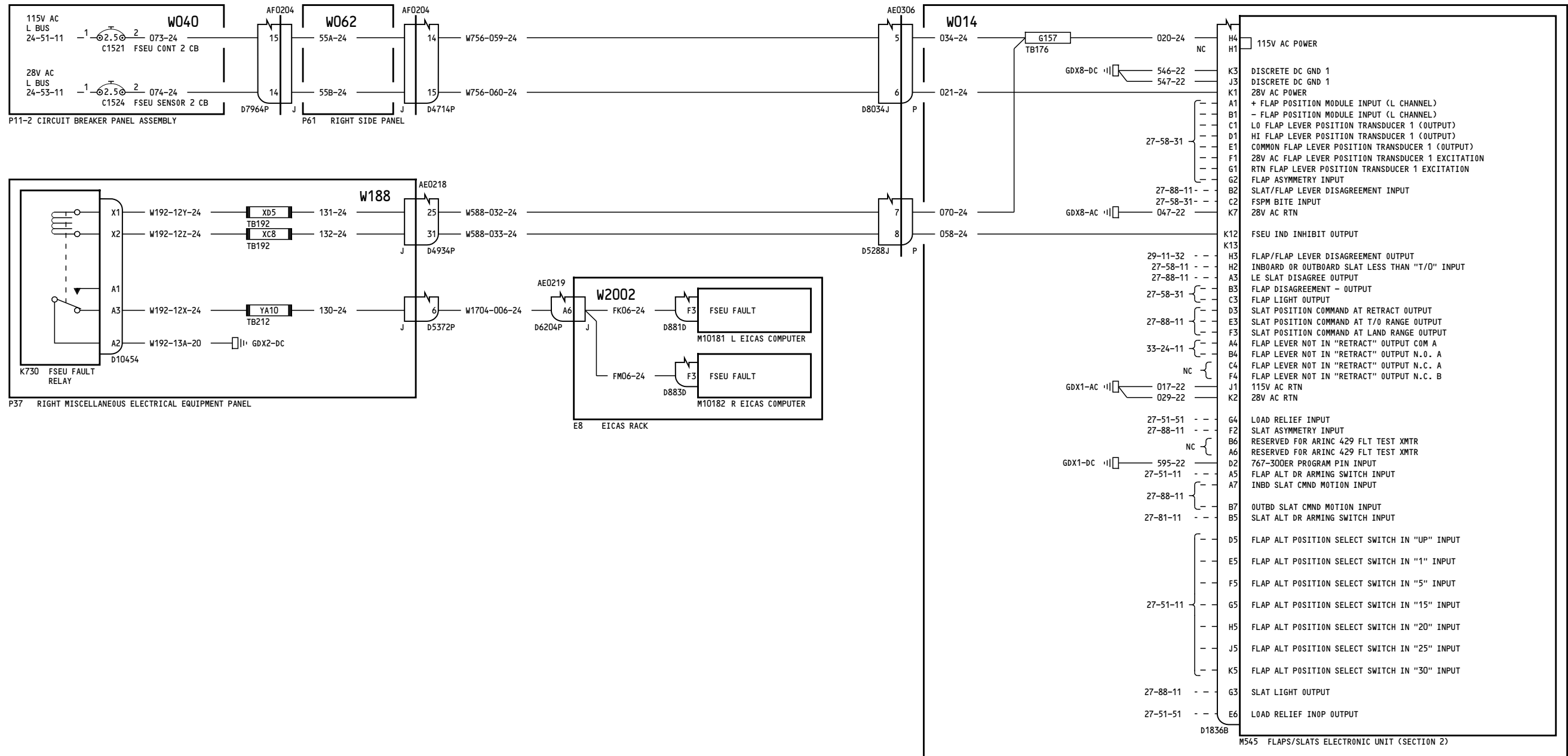

275-276

**FLAPS SLATS ELECTRONIC UNIT OUTPUT INTERFACE**

**27-51-61**

Page 4.1  
Sheet 2  
Jan 21/2005

D280T132

**27-51-61**

Page 4.1  
Sheet 2  
Jan 21/2005



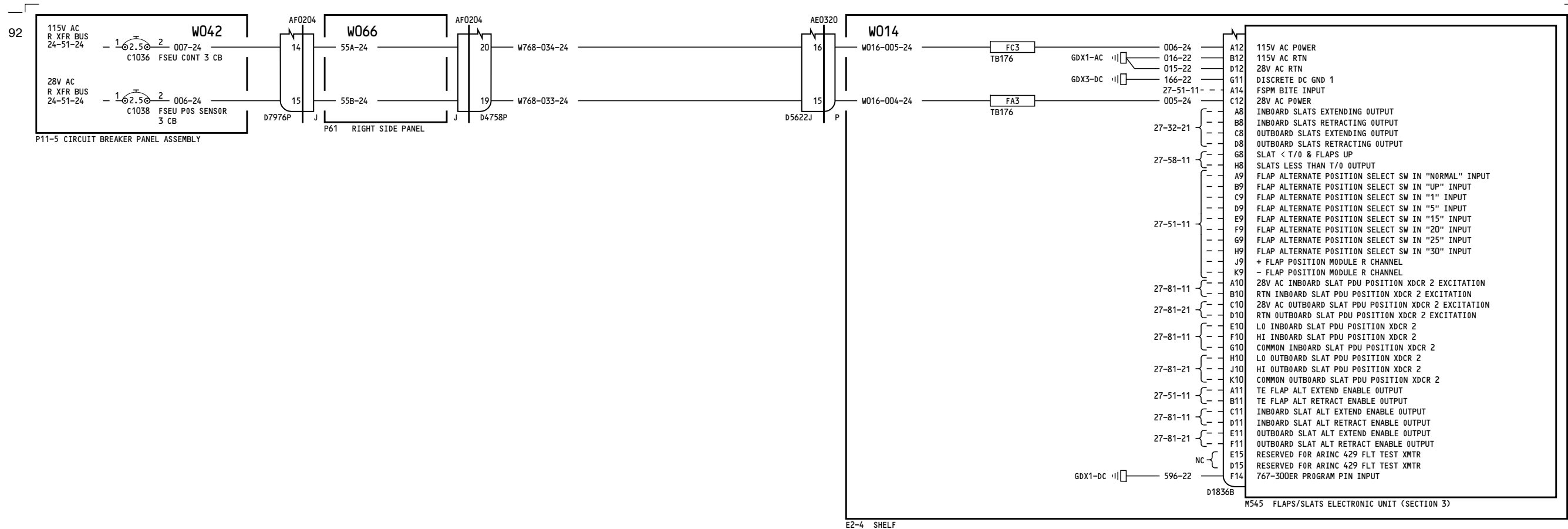

275-276

**FLAPS SLATS ELECTRONIC UNIT OUTPUT INTERFACE**

**27-51-61**

Page 4.1  
 Sheet 3  
 Jan 21/2005

D280T132

**27-51-61**

Page 4.1  
 Sheet 3  
 Jan 21/2005

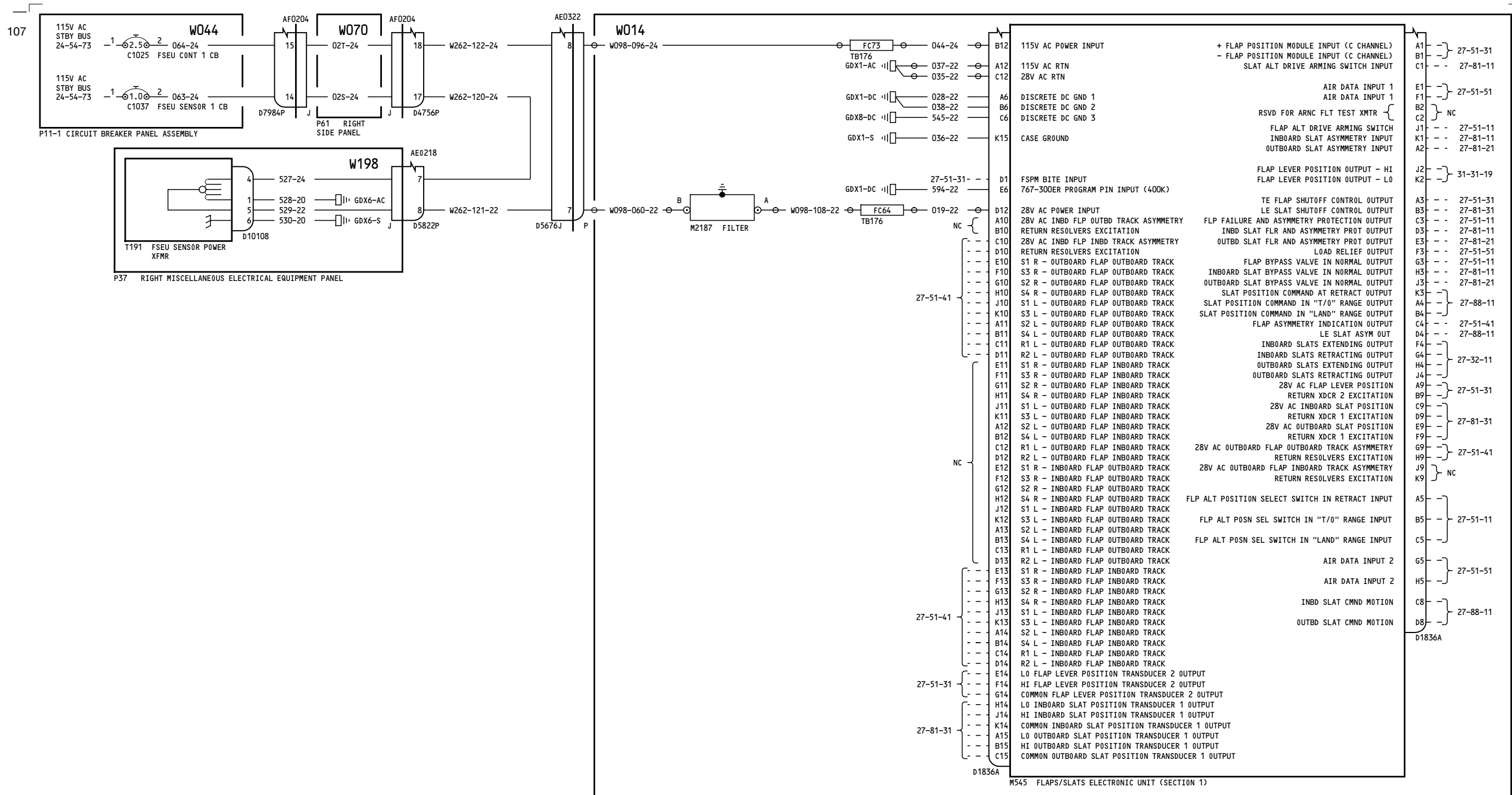

E2-4 SHELF

275-276

**FLAPS SLATS ELECTRONIC UNIT OUTPUT INTERFACE**

**27-51-61**

Page 4.2  
Sheet 1  
Jan 21/2005

D280T132

Incorporates  
27-0108 R02  
27-0131

**27-51-61**

Page 4.2  
Sheet 1  
Jan 21/2005

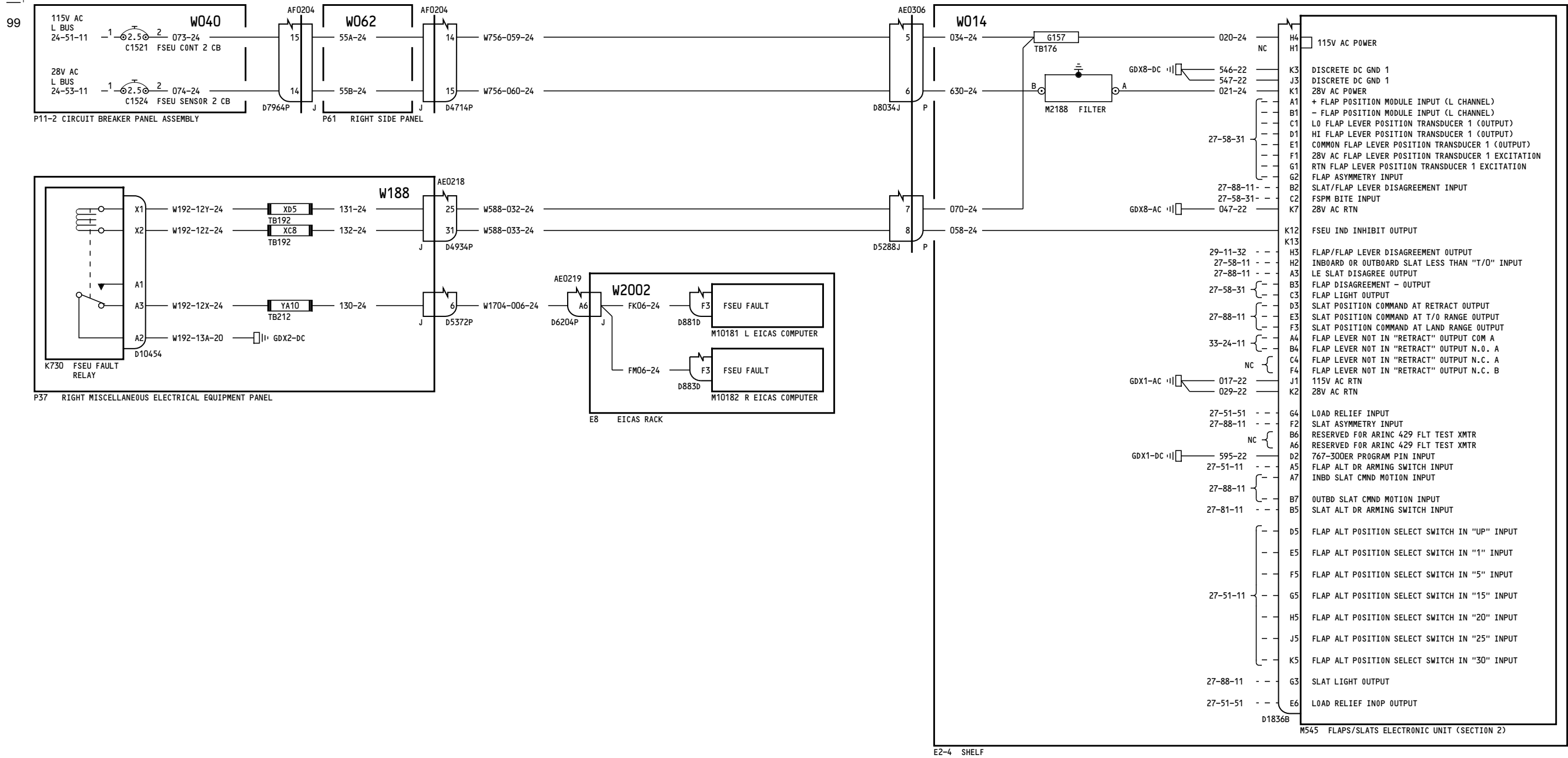

275-276

**FLAPS SLATS ELECTRONIC UNIT OUTPUT INTERFACE**

**27-51-61**

Page 4.2  
Sheet 2  
Jan 21/2005

D280T132

Incorporates  
27-0131

**27-51-61**

Page 4.2  
Sheet 2  
Jan 21/2005

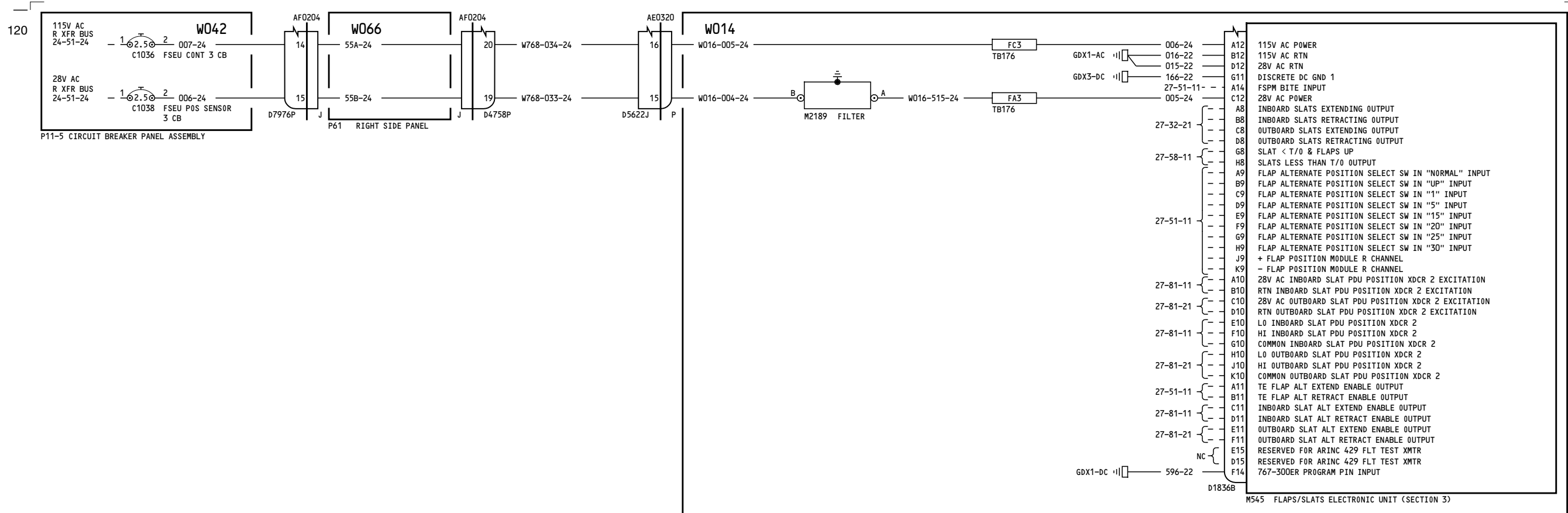

275-276

**FLAPS SLATS ELECTRONIC UNIT OUTPUT INTERFACE**

**27-51-61**

Page 4.2  
Sheet 3  
Jan 21/2005

D280T132

Incorporates  
27-0131

**27-51-61**

Page 4.2  
Sheet 3  
Jan 21/2005

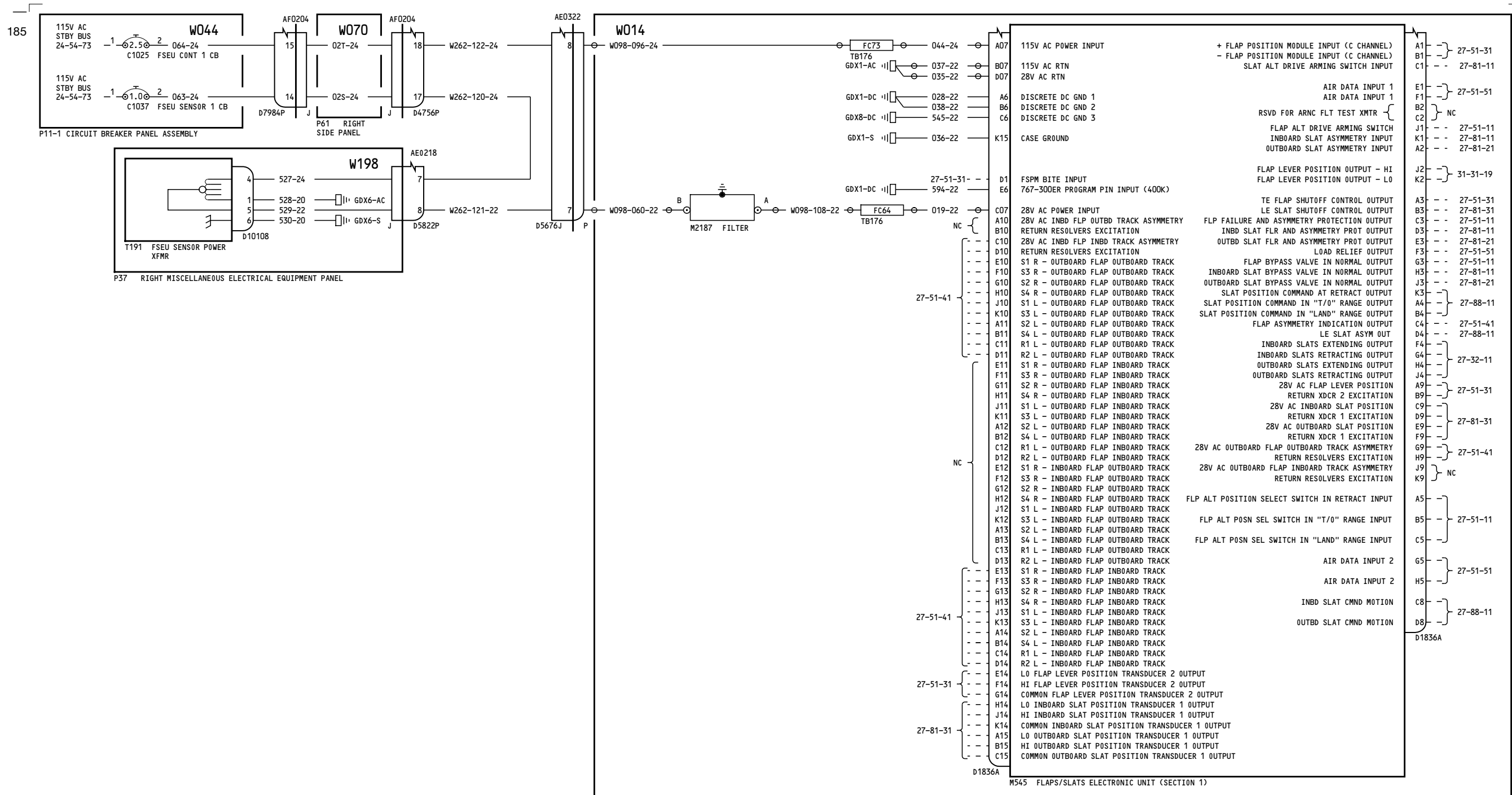

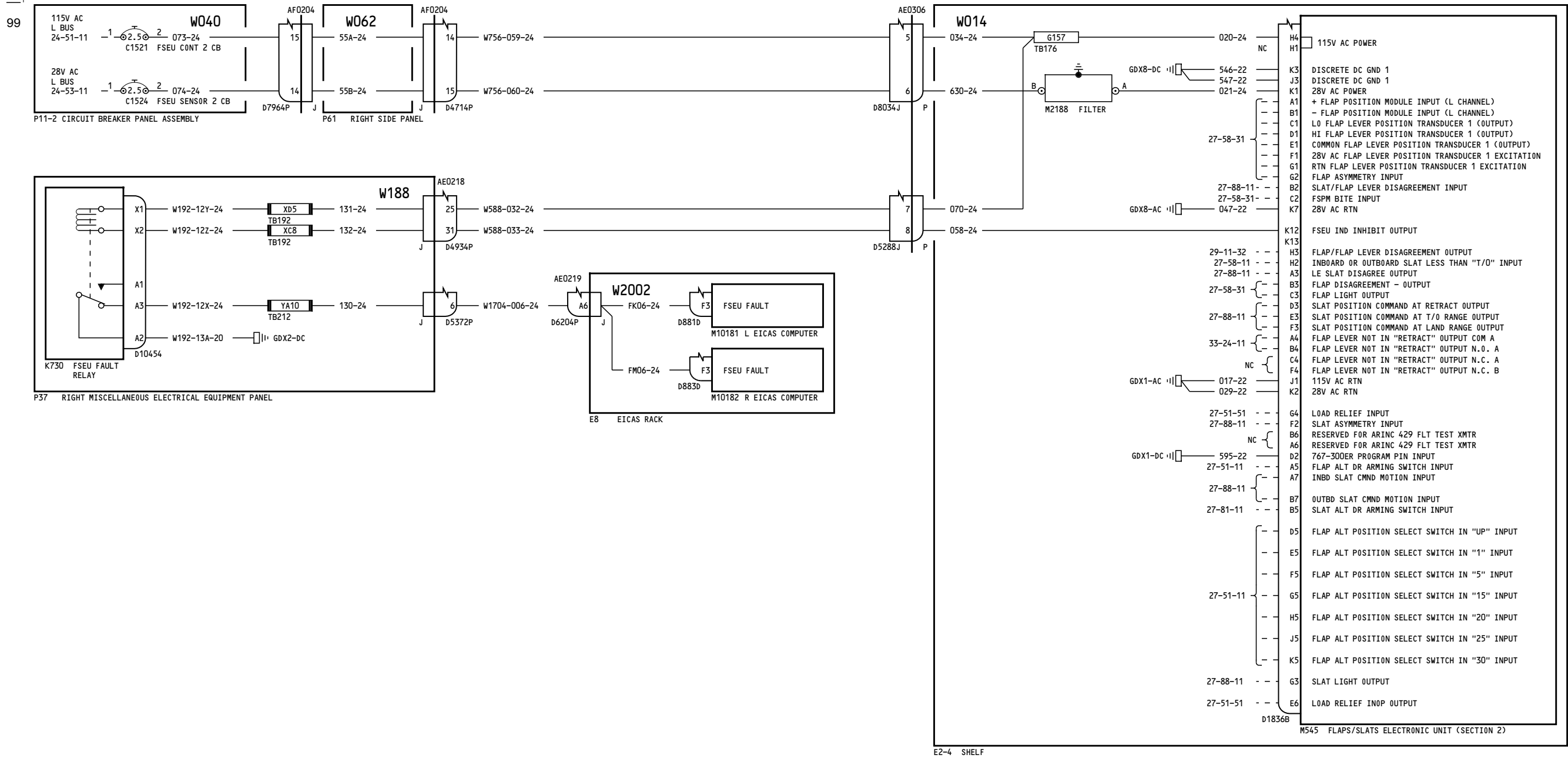

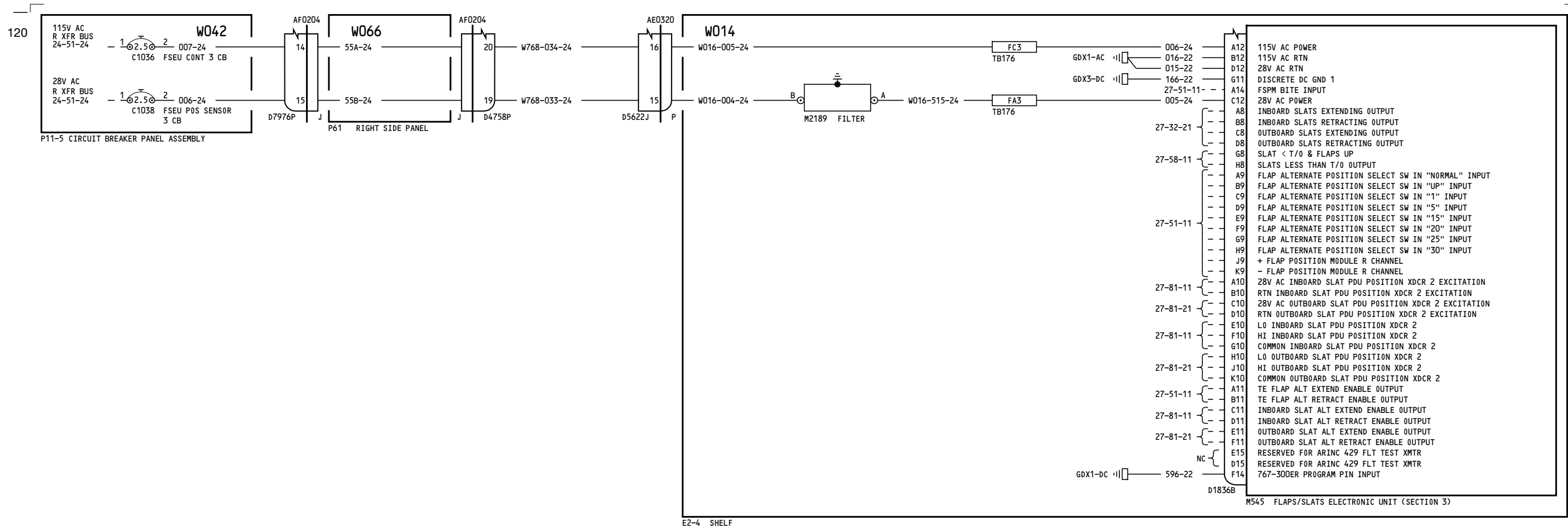

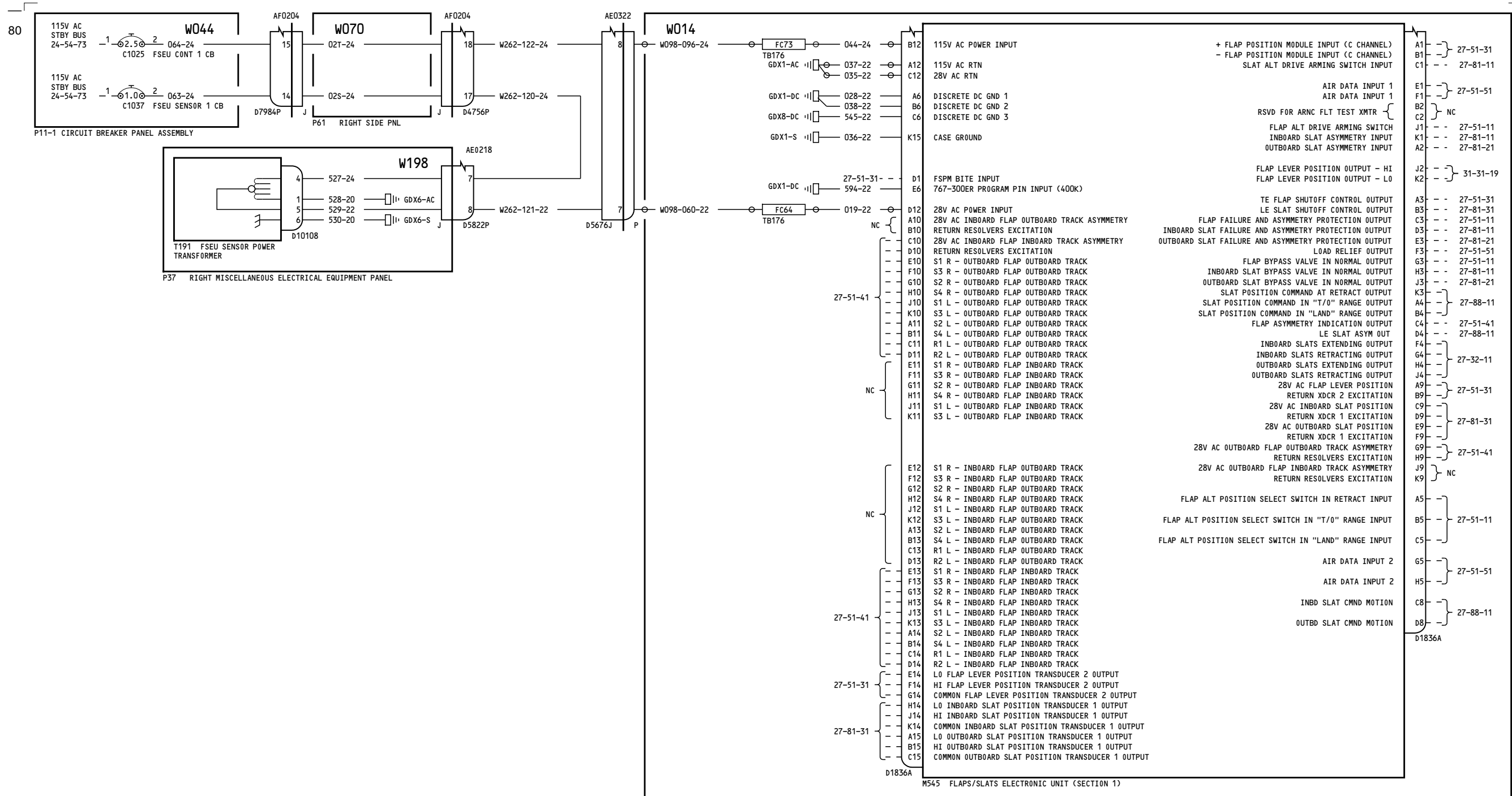

E2-4 SHELF



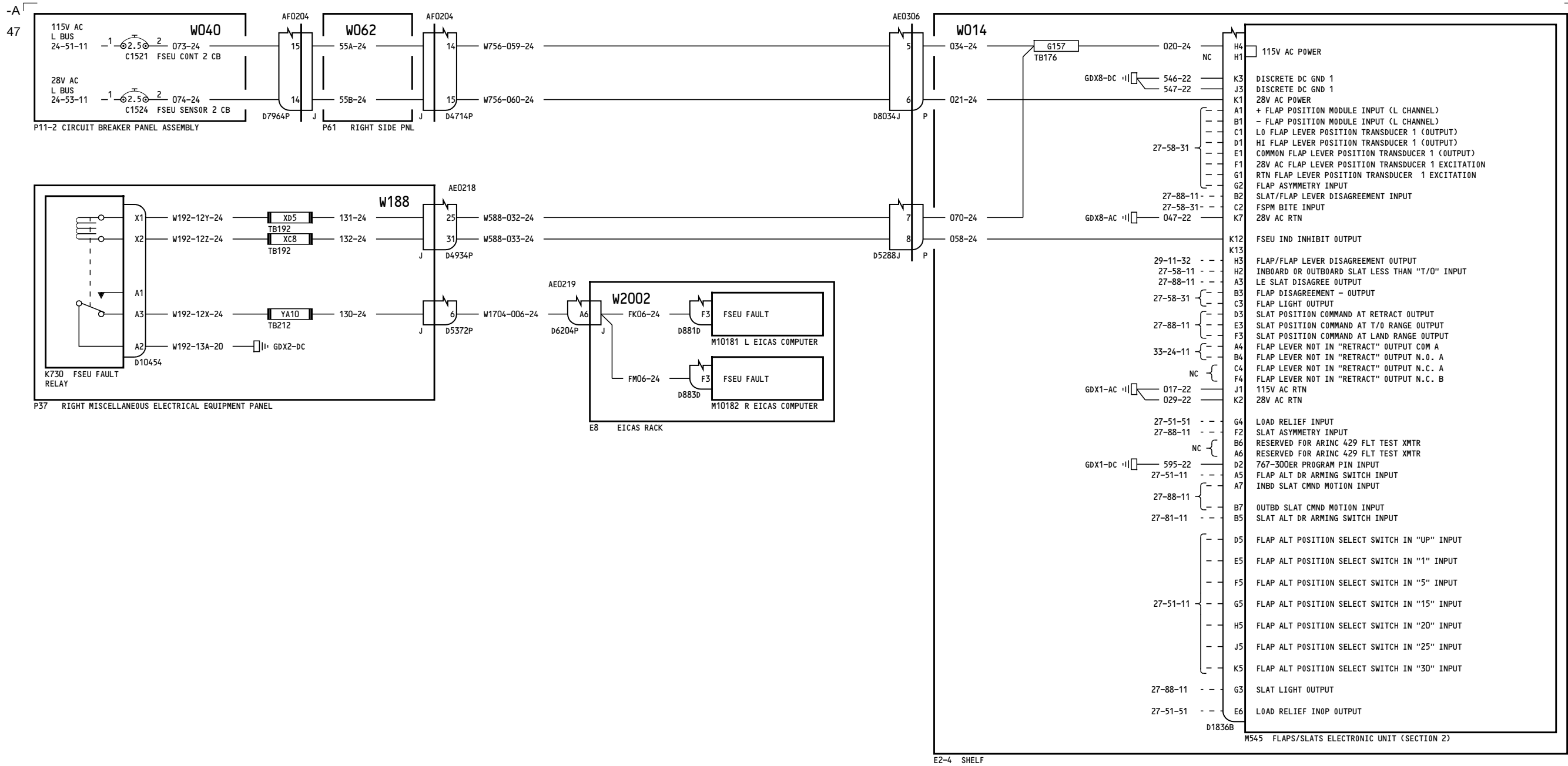

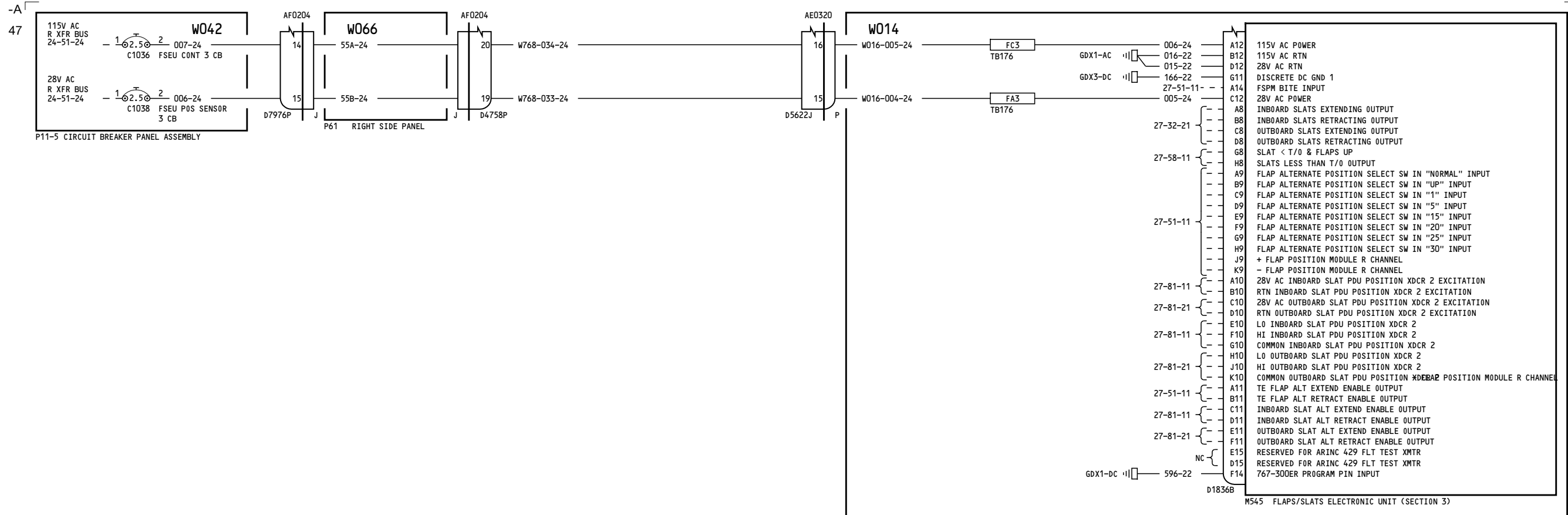

E2-4 SHELF

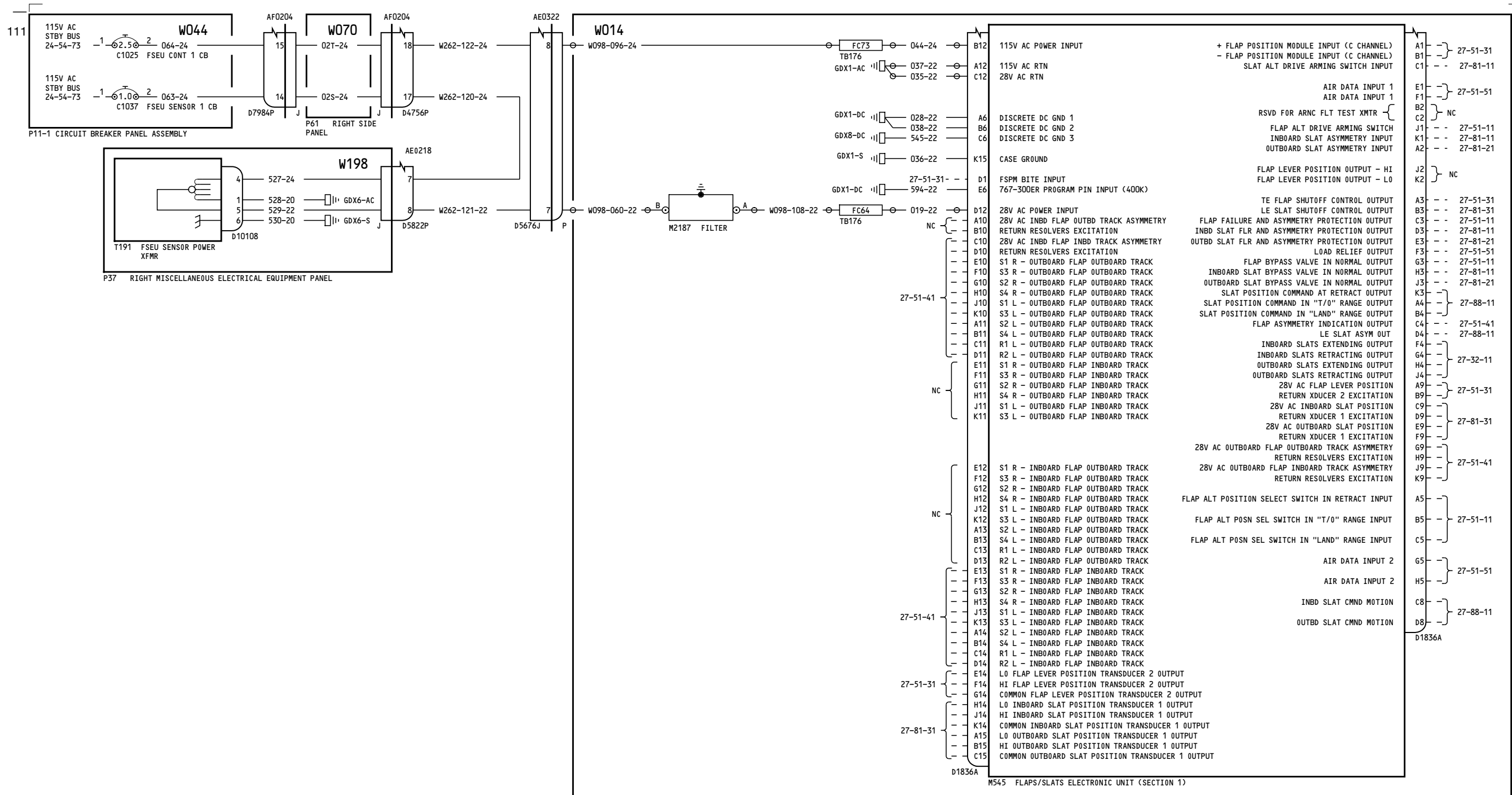

E2-4 SHELF

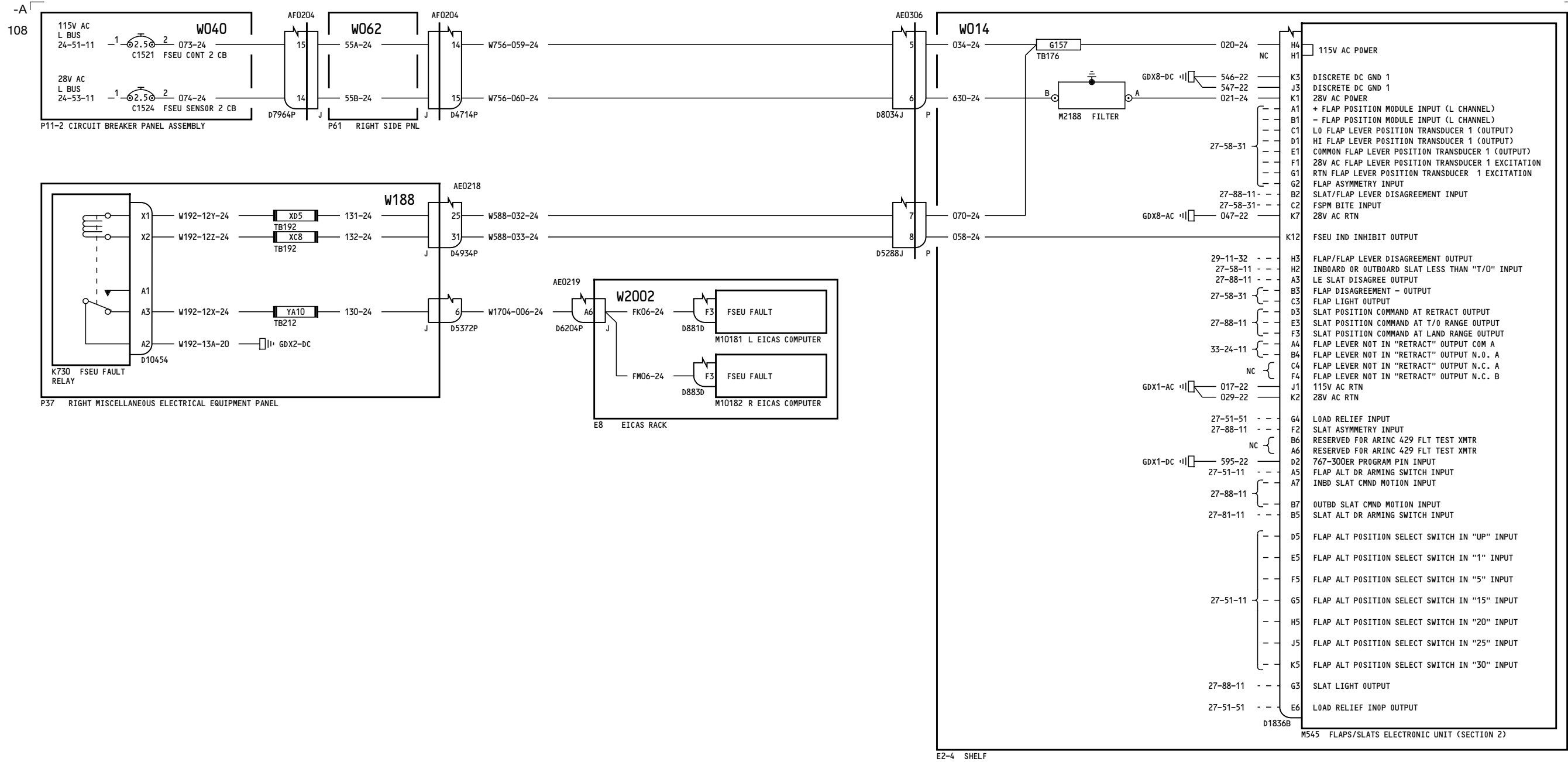

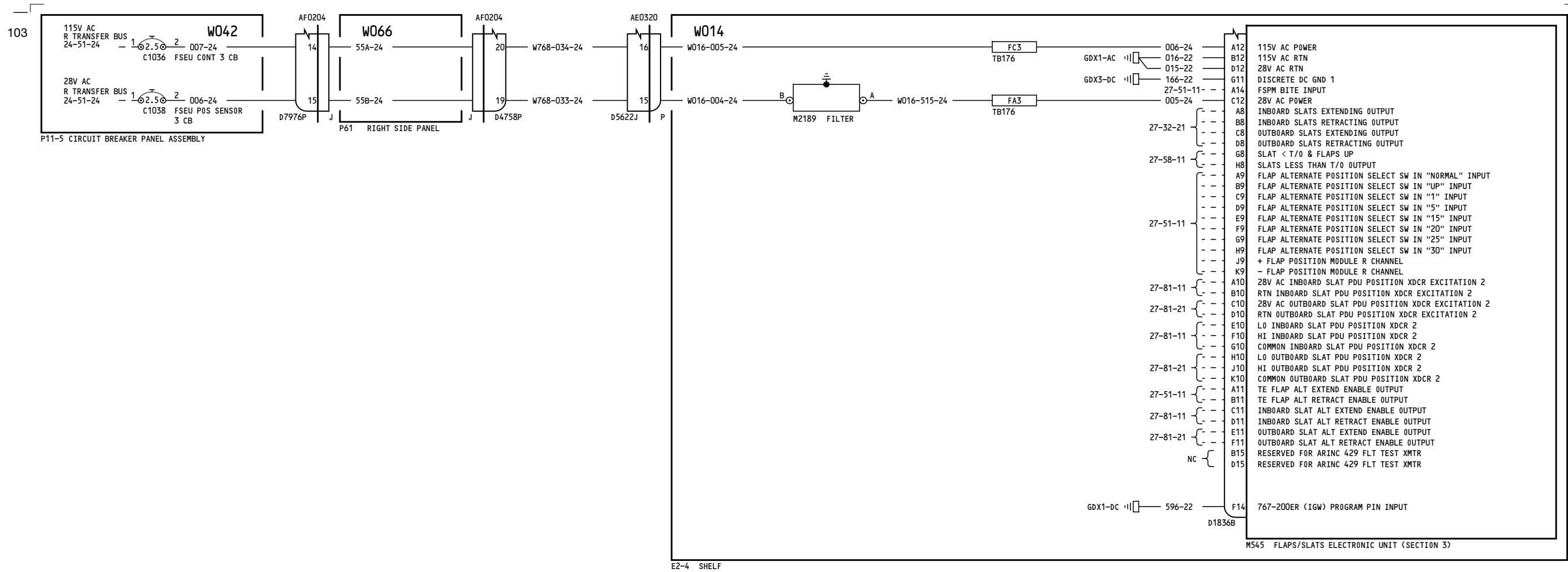

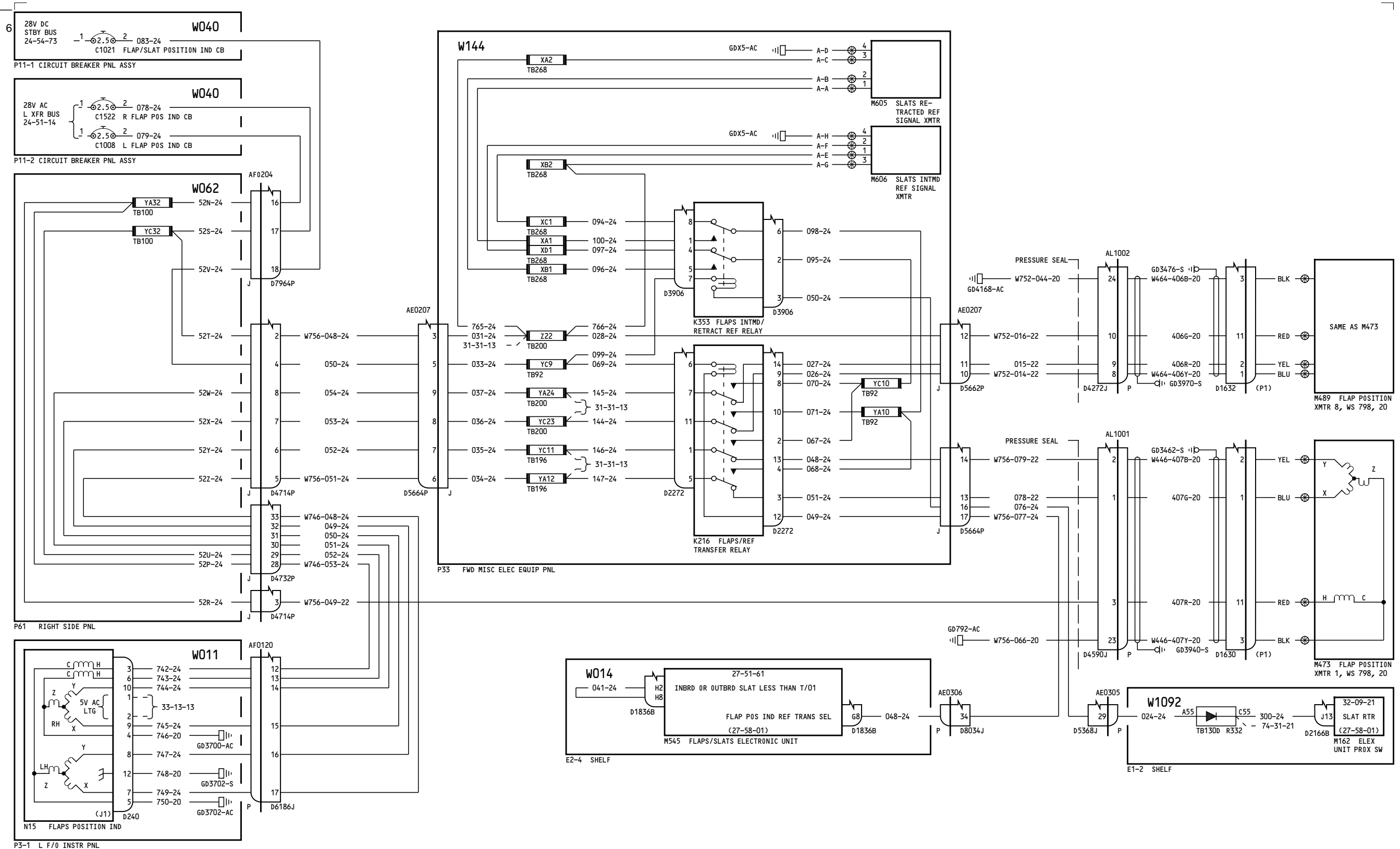

050-099, 150-155, 162-165, 275-276

**TRAILING EDGE FLAP POSITION INDICATION**

**27-58-11**

Page 1

Jan 21/2005

D280T132

**27-58-11**

Page 1

Jan 21/2005

**27-58-11**

Page 1

Jan 21/2005

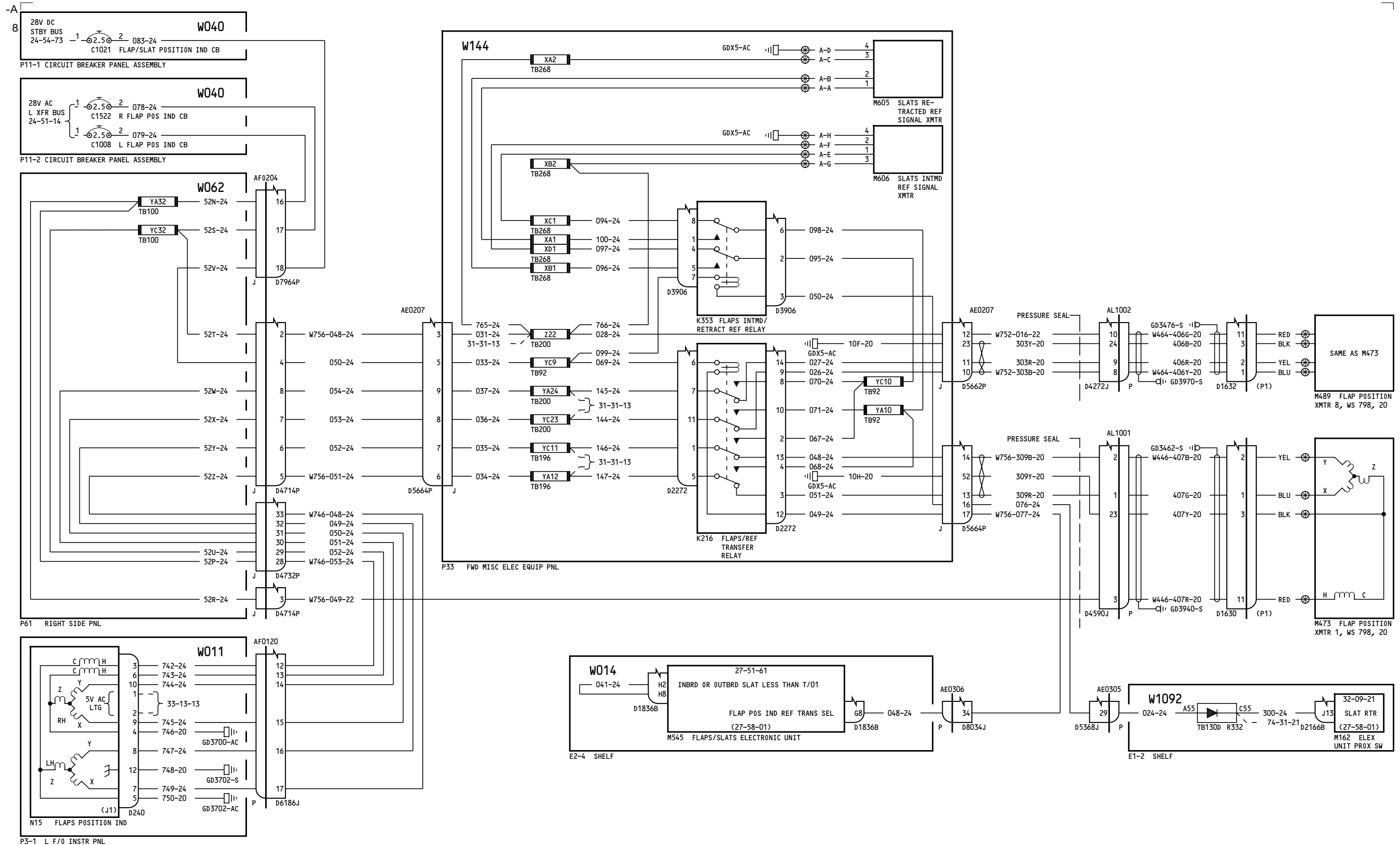

156-157, 166-199, 277-299

**TRAILING EDGE FLAP POSITION INDICATION**

**27-58-11**

Page 2

Jan 21/2005

D280T132

**27-58-11**

Page 2

Jan 21/2005

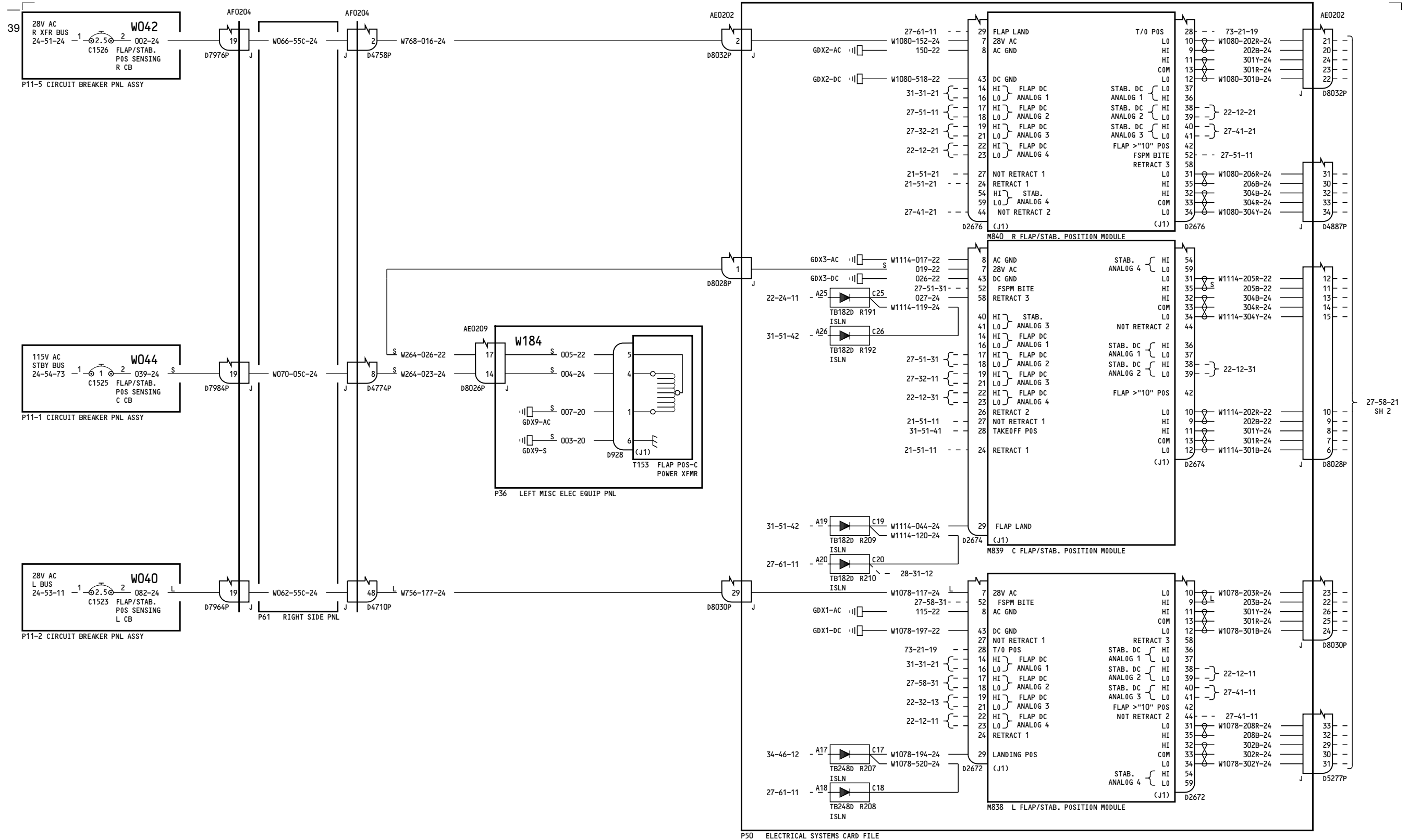

P50 ELECTRICAL SYSTEMS CARD FILE

050, 155-199

**FLAP STABILIZER POSITION SENSING**

**27-58-21**

Page 1  
Sheet 1  
Jan 21/2005

D280T132

**27-58-21**

Page 1  
Sheet 1  
Jan 21/2005



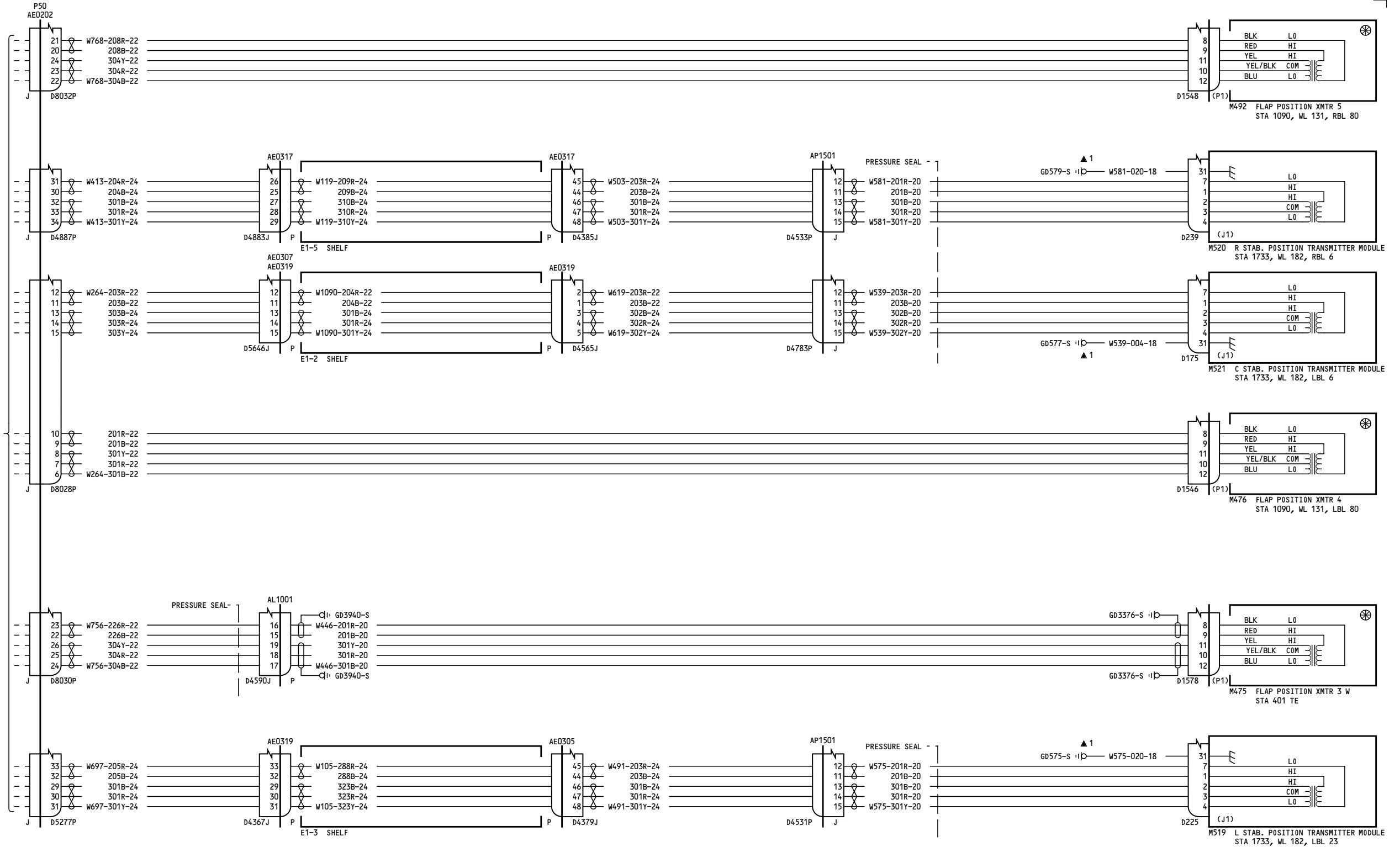

050, 155-199

**FLAP STABILIZER POSITION SENSING**

**27-58-21**

Page 1  
Sheet 2  
Jan 21/2005

D280T132

**27-58-21**

Page 1  
Sheet 2  
Jan 21/2005

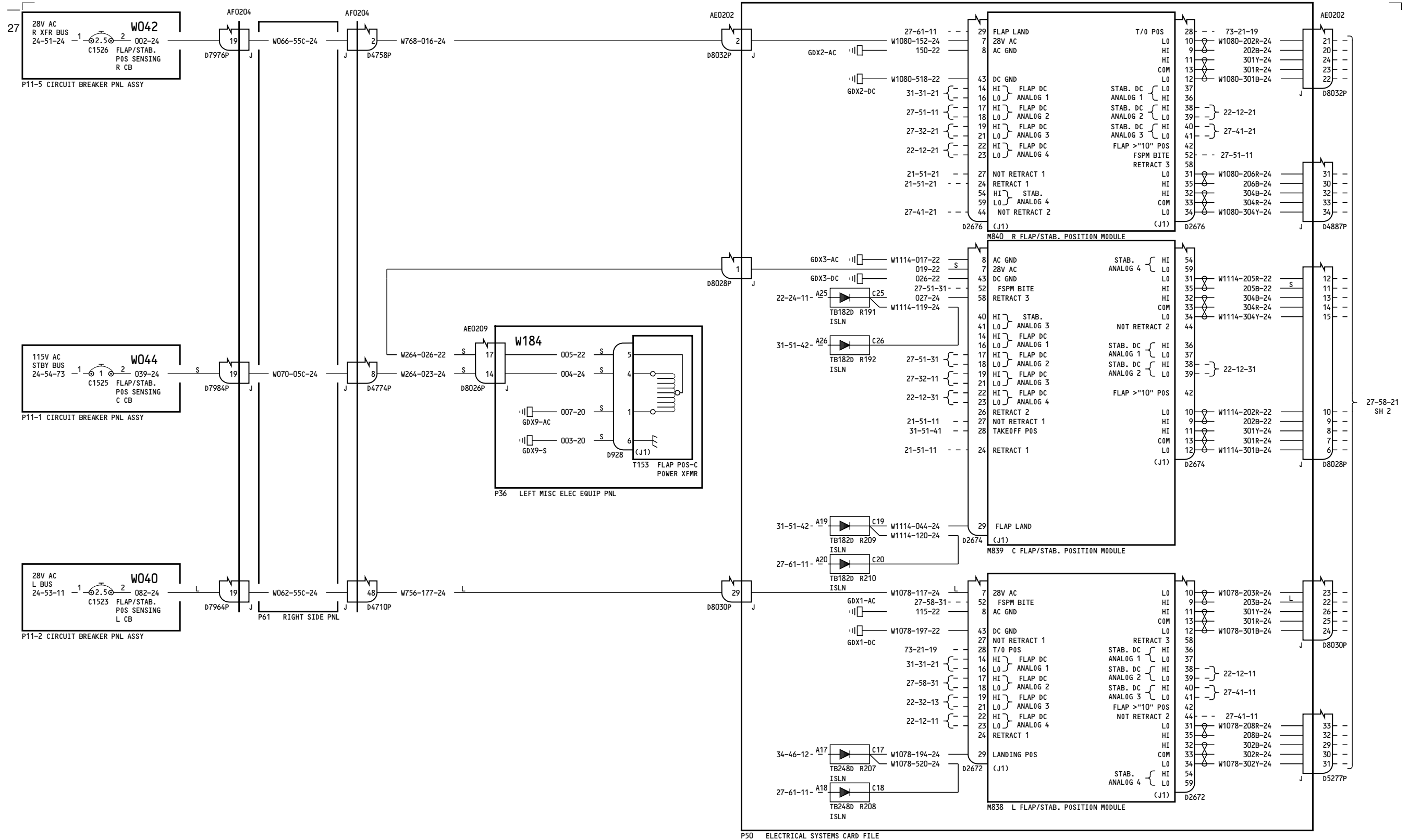

051-099, 150-154

**FLAP STABILIZER POSITION SENSING**

**27-58-21**

Page 2  
Sheet 1  
Jan 21/2005

D280T132

**27-58-21**

Page 2  
Sheet 1  
Jan 21/2005

27

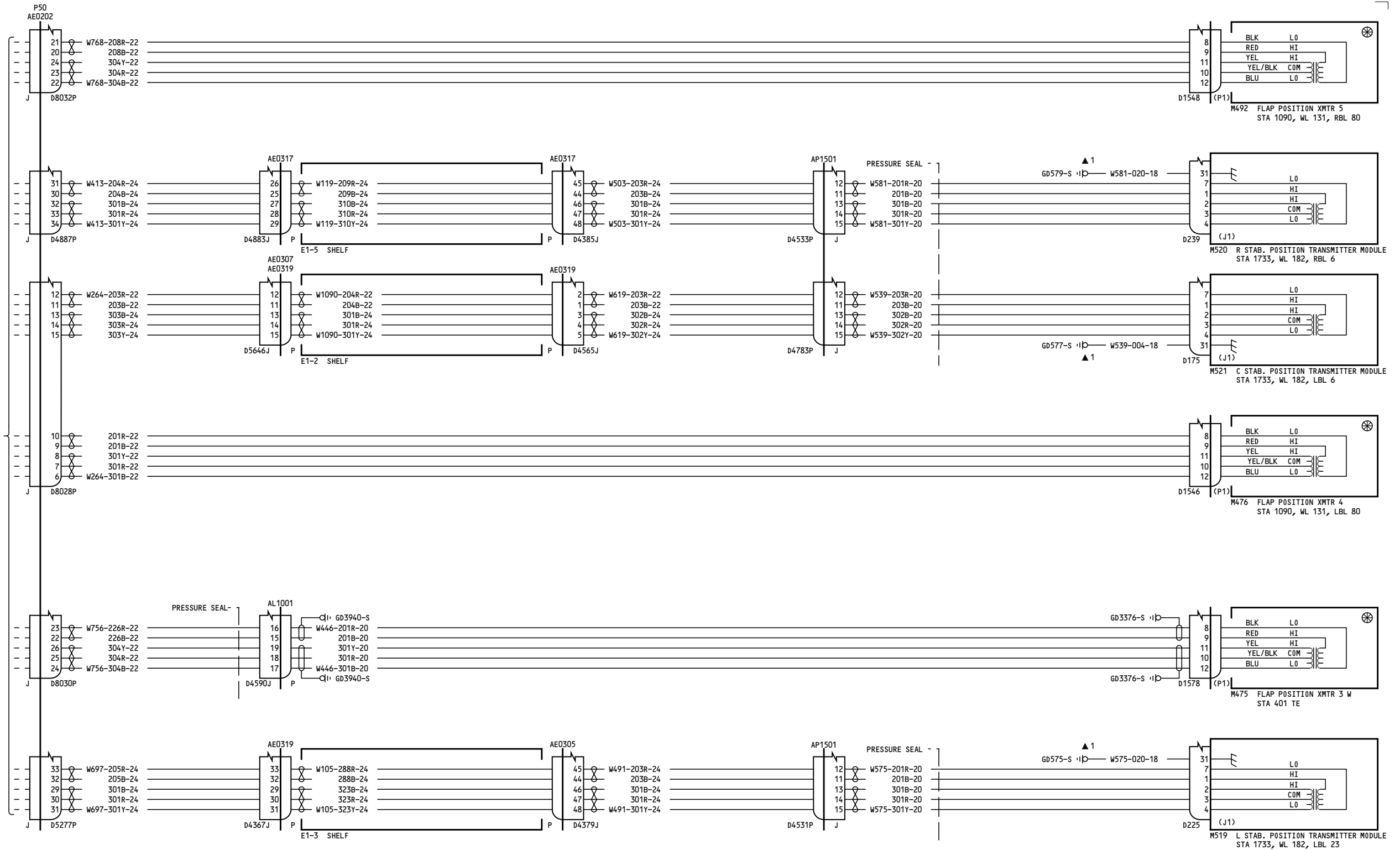

051-099, 150-154

**FLAP STABILIZER POSITION SENSING**

**27-58-21**

Page 2  
Sheet 2  
Jan 21/2005

D280T132

**27-58-21**

Page 2  
Sheet 2  
Jan 21/2005

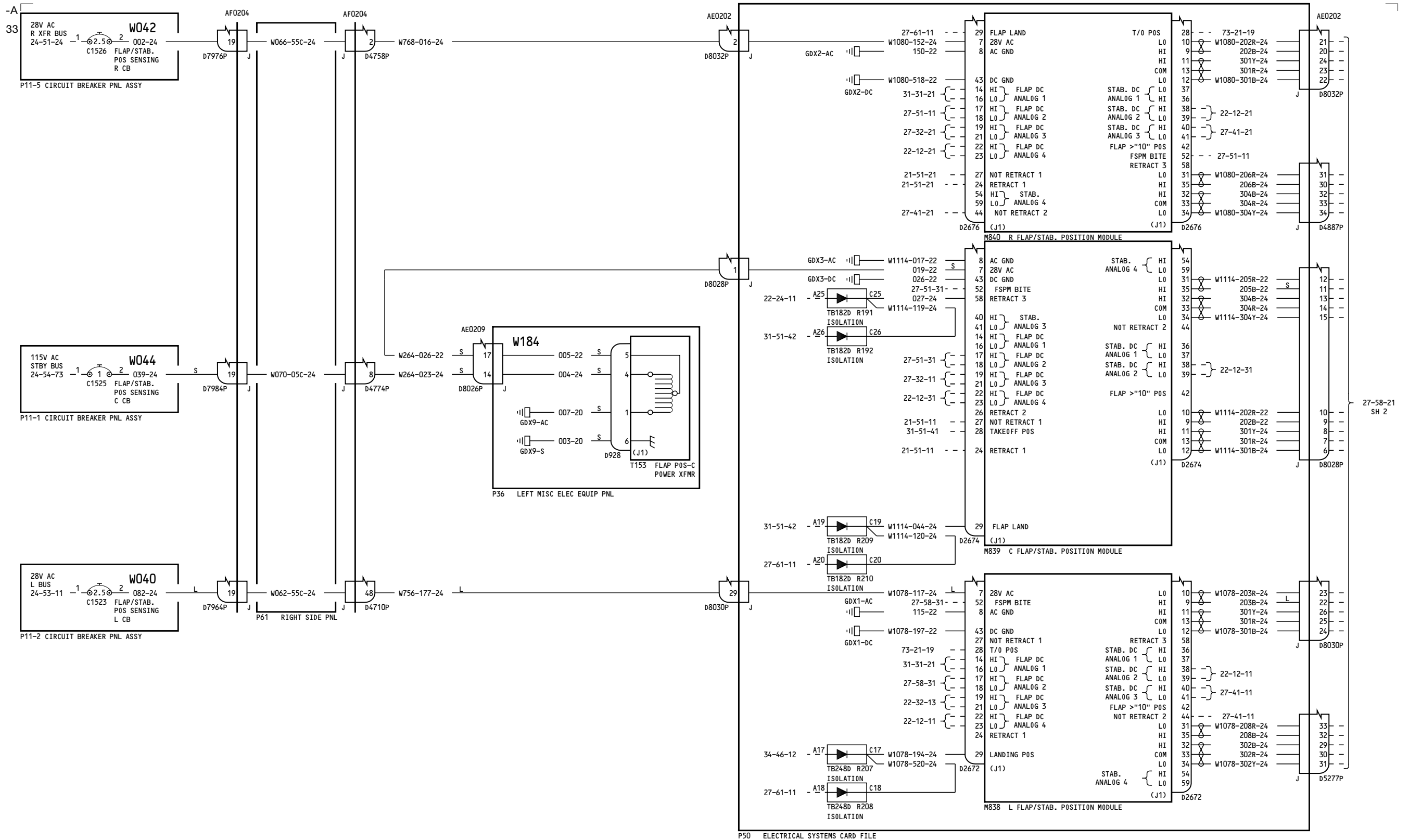

P50 ELECTRICAL SYSTEMS CARD FILE

275-299

**FLAP STABILIZER POSITION SENSING**

**27-58-21**

Page 3  
Sheet 1  
Jan 21/2005

D280T132

**27-58-21**

Page 3  
Sheet 1  
Jan 21/2005

-A  
33

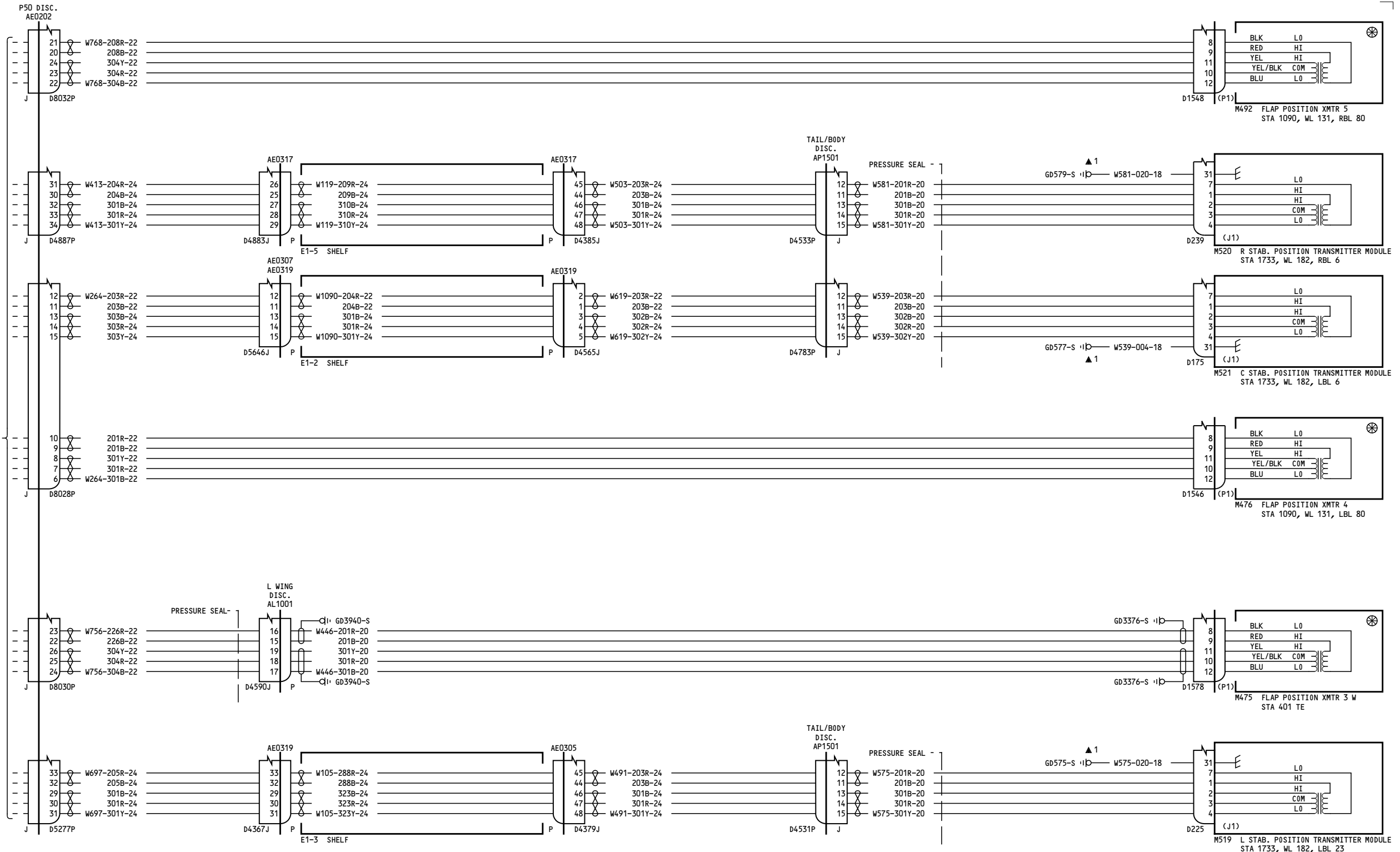

275-299

**FLAP STABILIZER POSITION SENSING**

**27-58-21**

Page 3  
Sheet 2  
Jan 21/2005

D280T132

**27-58-21**

Page 3  
Sheet 2  
Jan 21/2005

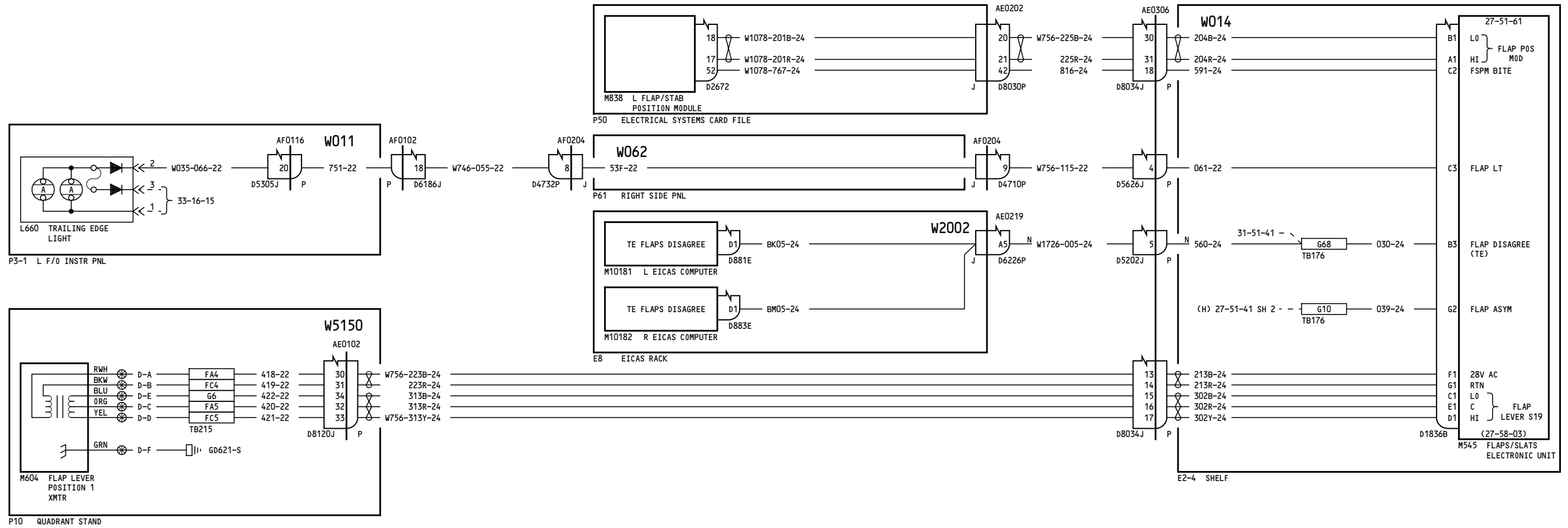

ALL	<p><b>FLAP MASTER INDICATION</b></p> <p>27-58-31</p> <p>Page 1</p> <p>Jan 21/2005</p> <p>D280T132</p>
-----	---

27-58-31

Page 1

Jan 21/2005

27-58-31

Page 1

Jan 21/2005

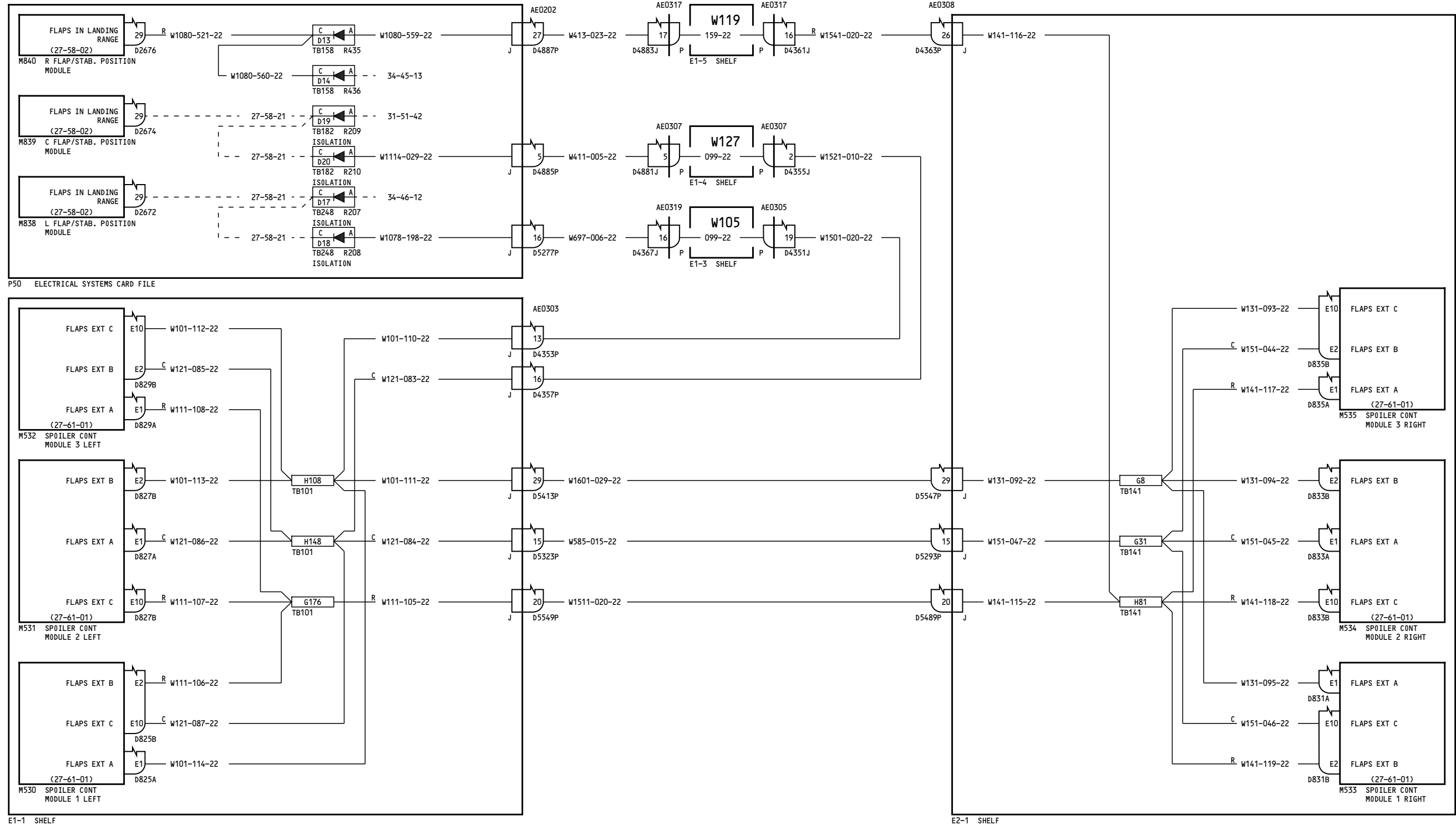

050-099, 155-156, 162-166

**SPOILER CONTROL-  
FLAPS INPUT**

D280T132

**27-61-11**

Page 1

Jan 21/2005

**27-61-11**

Page 1

Jan 21/2005

25

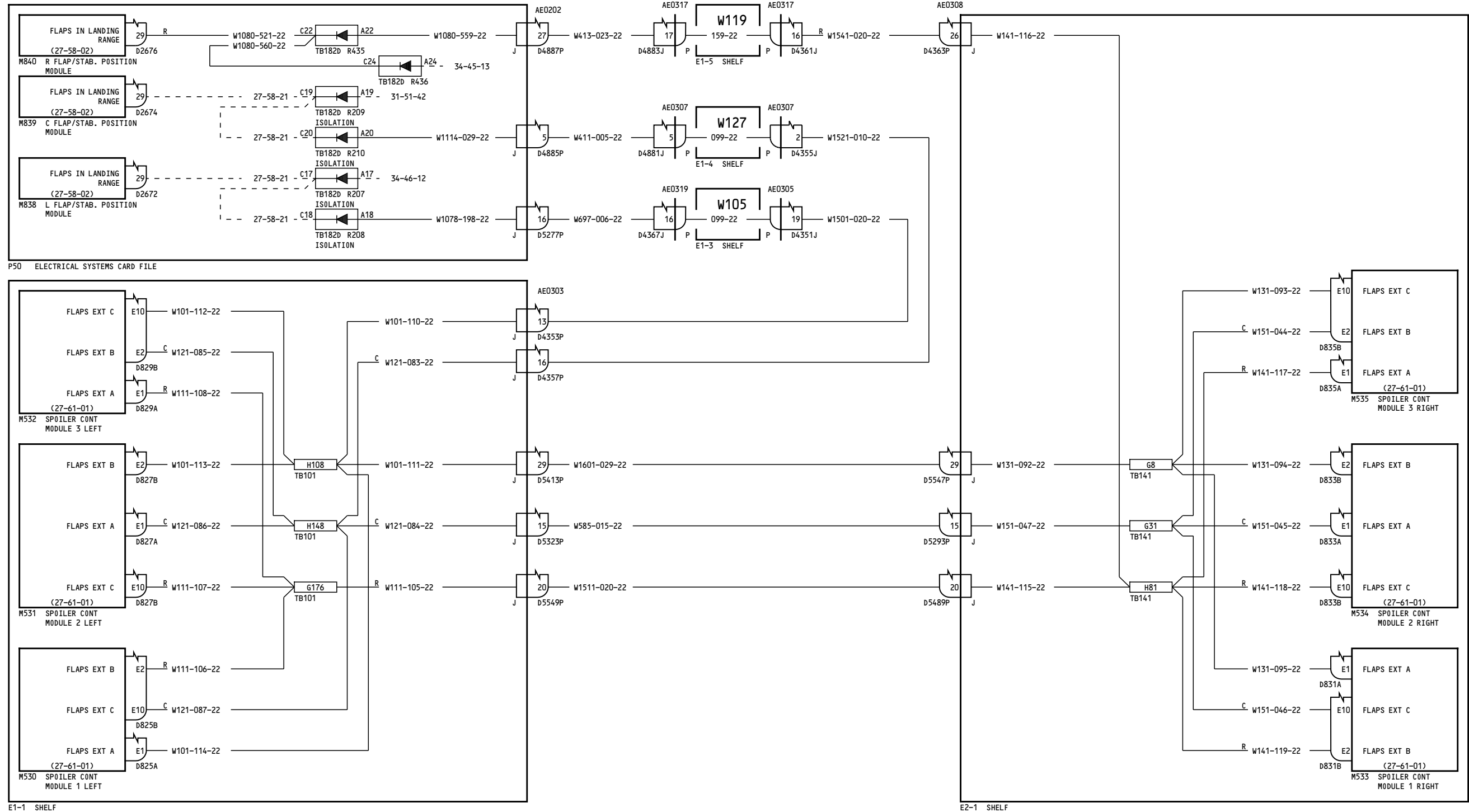

P50 ELECTRICAL SYSTEMS CARD FILE

E1-1 SHELF

E2-1 SHELF

150-152

**SPOILER CONTROL-  
FLAPS INPUT**

**27-61-11**

Page 2.1

Jan 21/2005

D280T132

Incorporates  
34-0091 R01

**27-61-11**

Page 2.1

Jan 21/2005



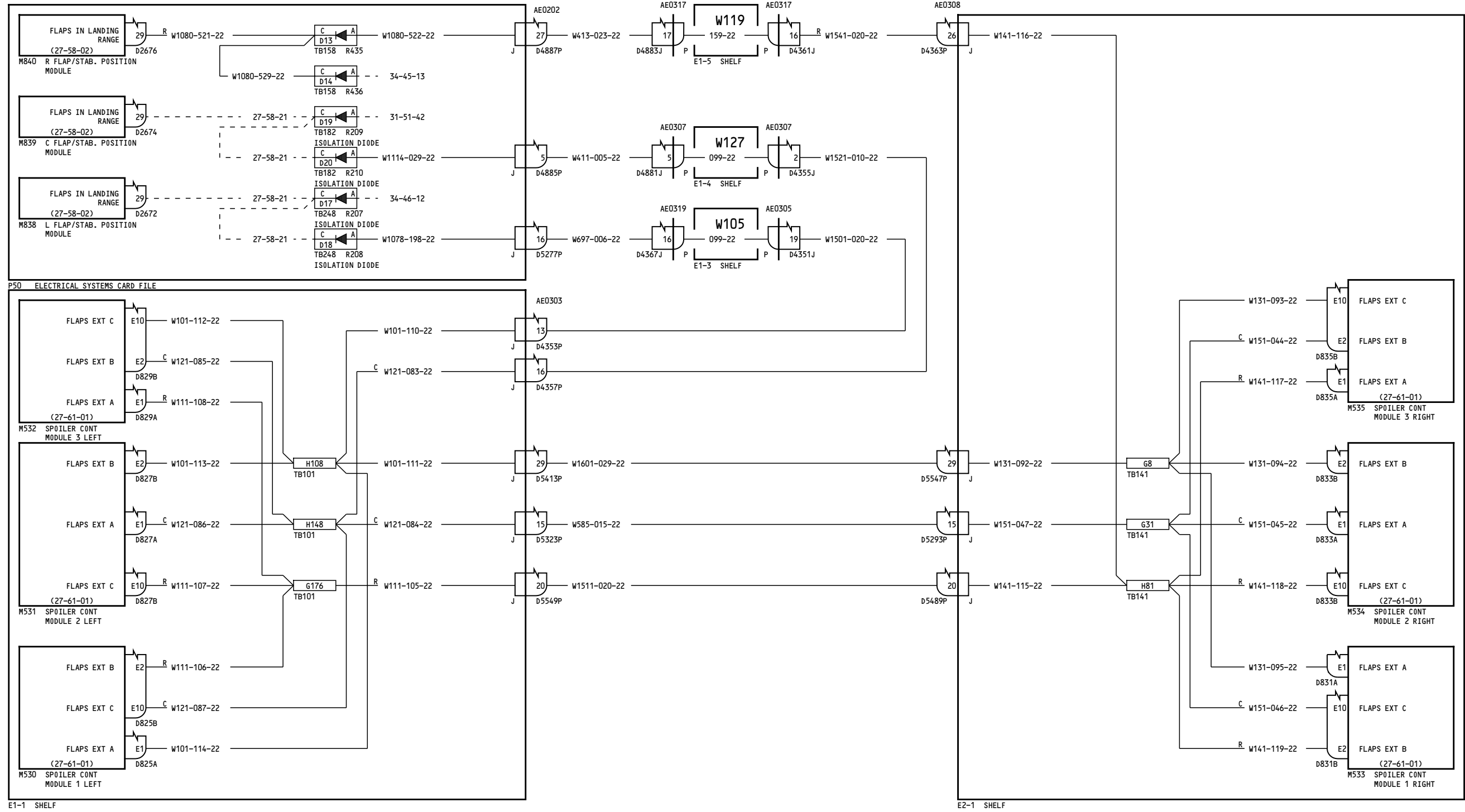

153-154

### SPOILER CONTROL- FLAPS INPUT

**27-61-11**

Page 3

D280T132

Jan 21/2005

**27-61-11**

Page 3

Jan 21/2005

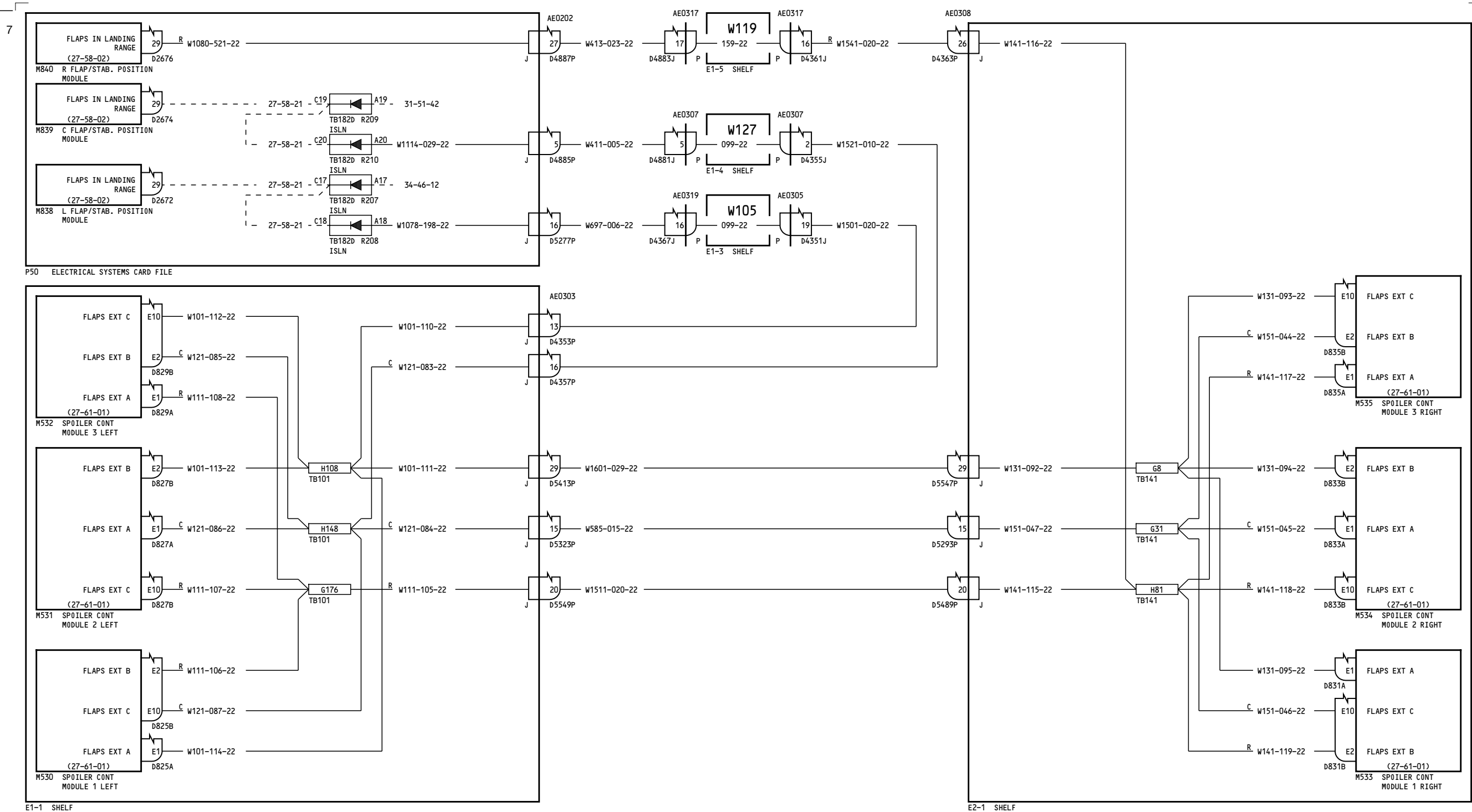

157, 167-199, 277-299

SPOILER CONTROL-  
FLAPS INPUT

27-61-11

Page 4

D280T132

Jan 21/2005

27-61-11

Page 4

Jan 21/2005

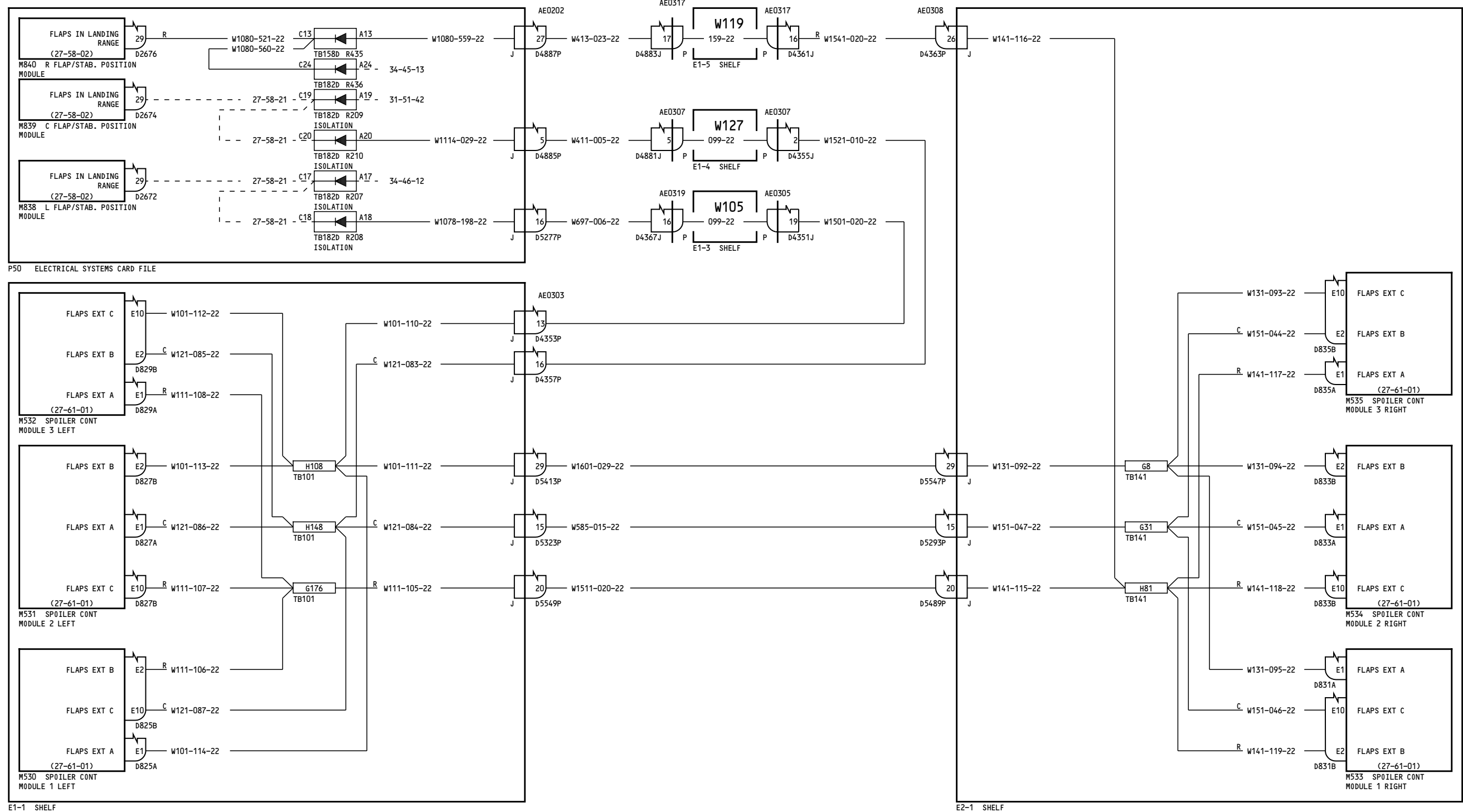

275-276

**SPOILER CONTROL-  
FLAPS INPUT**

**27-61-11**

Incorporates  
34-0091 R01

**27-61-11**

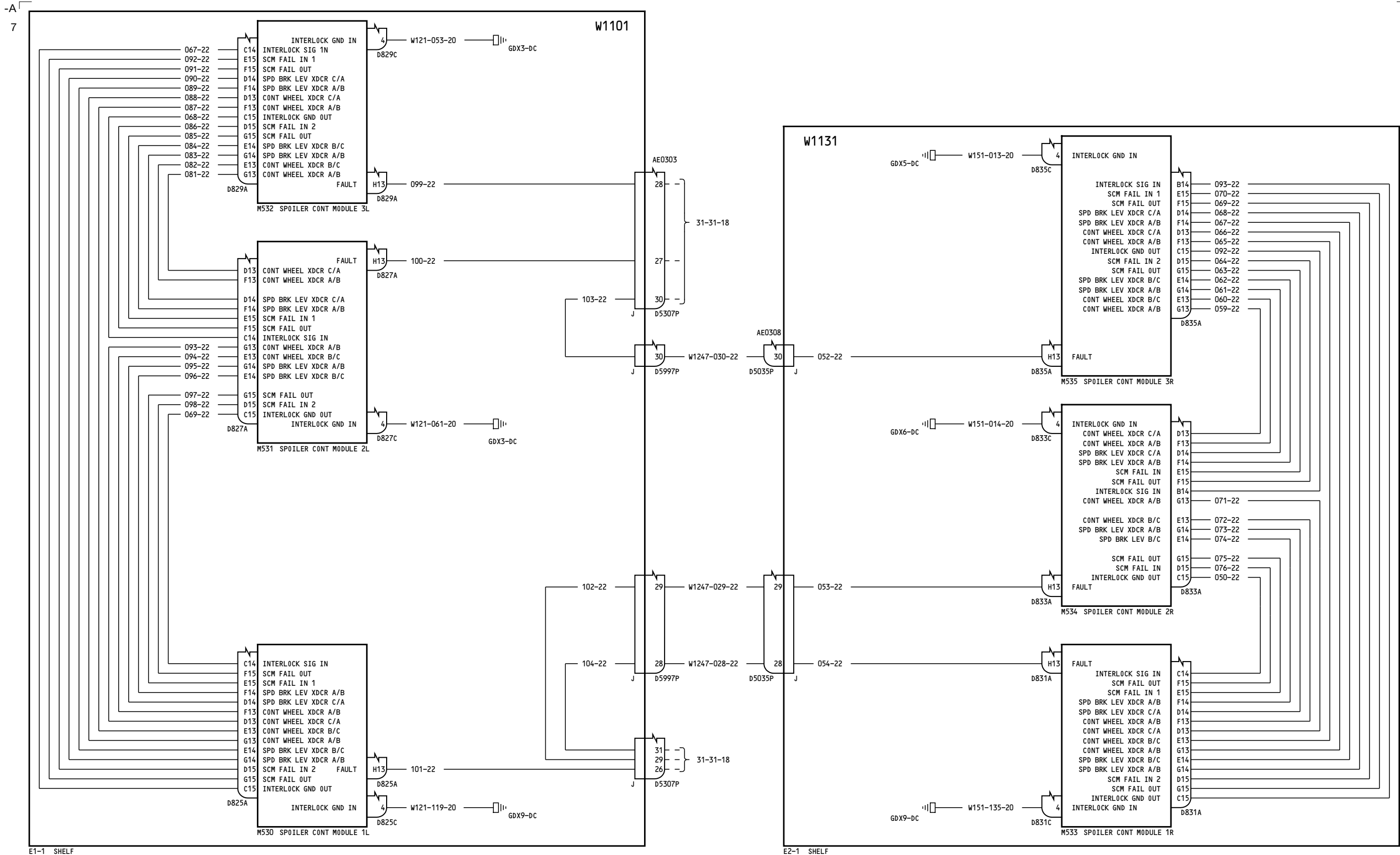

ALL

SPOILER CONTROL-  
FAULT ANNUNCIATION  
  
D280T132

27-61-12  
Page 1  
Sheet 1  
Jan 21/2005

27-61-12  
Page 1  
Sheet 1  
Jan 21/2005

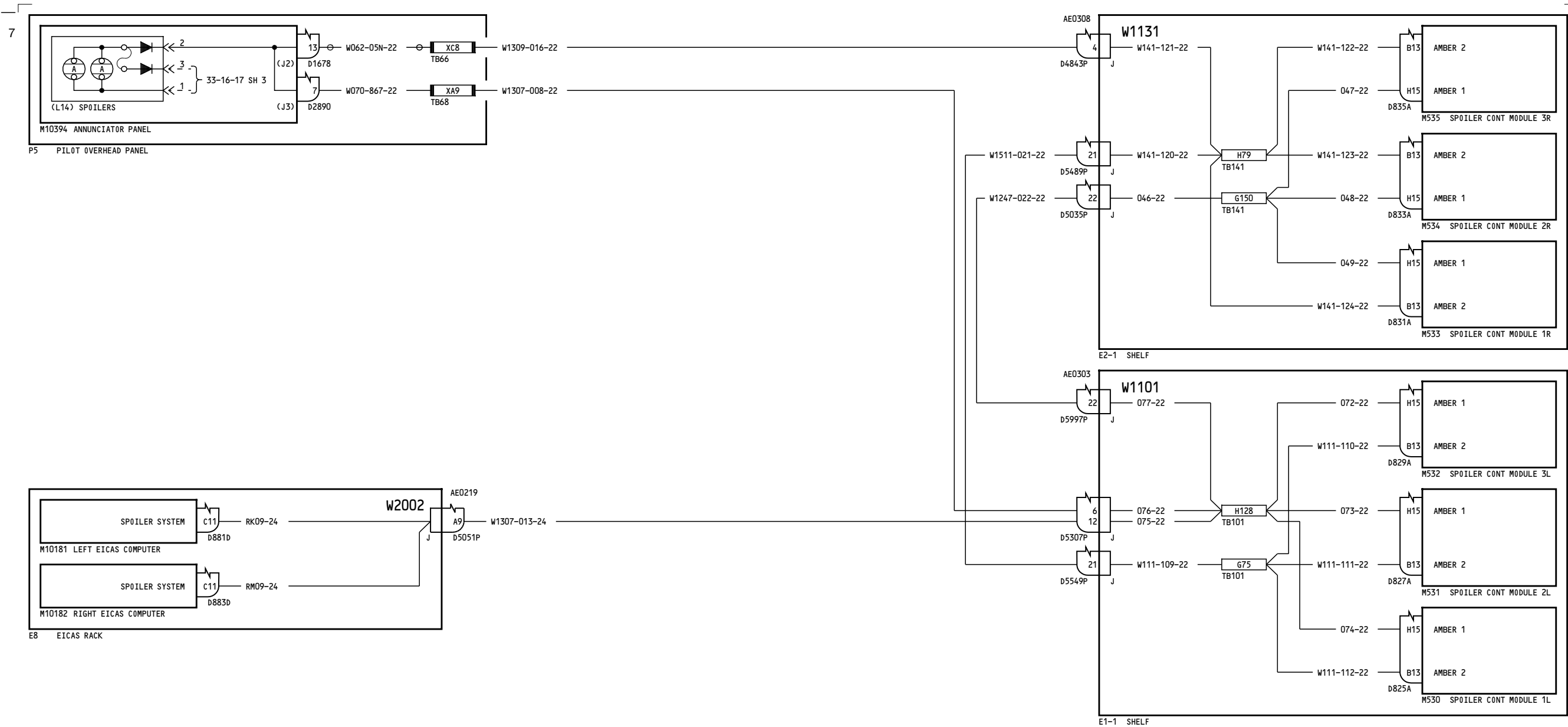

ALL

**SPOILER CONTROL-  
FAULT ANNUNCIATION**

D280T132

**27-61-12**

Page 1  
Sheet 2  
Jan 21/2005

**27-61-12**

Page 1  
Sheet 2  
Jan 21/2005

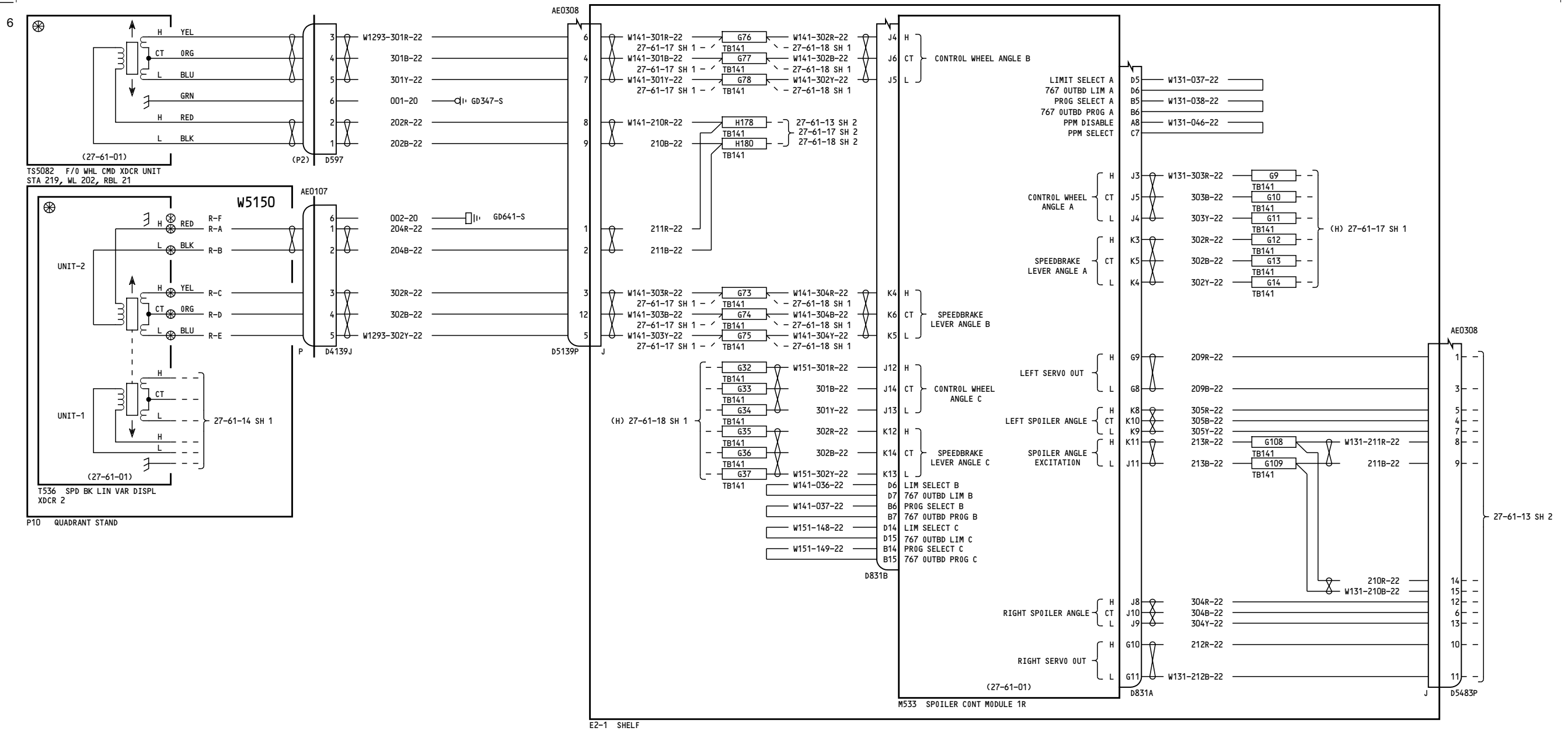

050-099, 150-199

**SPOILER CONTROL-SURFACE PANELS 1 & 12**

**27-61-13**

Page 1  
Sheet 1  
Jan 21/2005

D280T132

**27-61-13**

Page 1  
Sheet 1  
Jan 21/2005

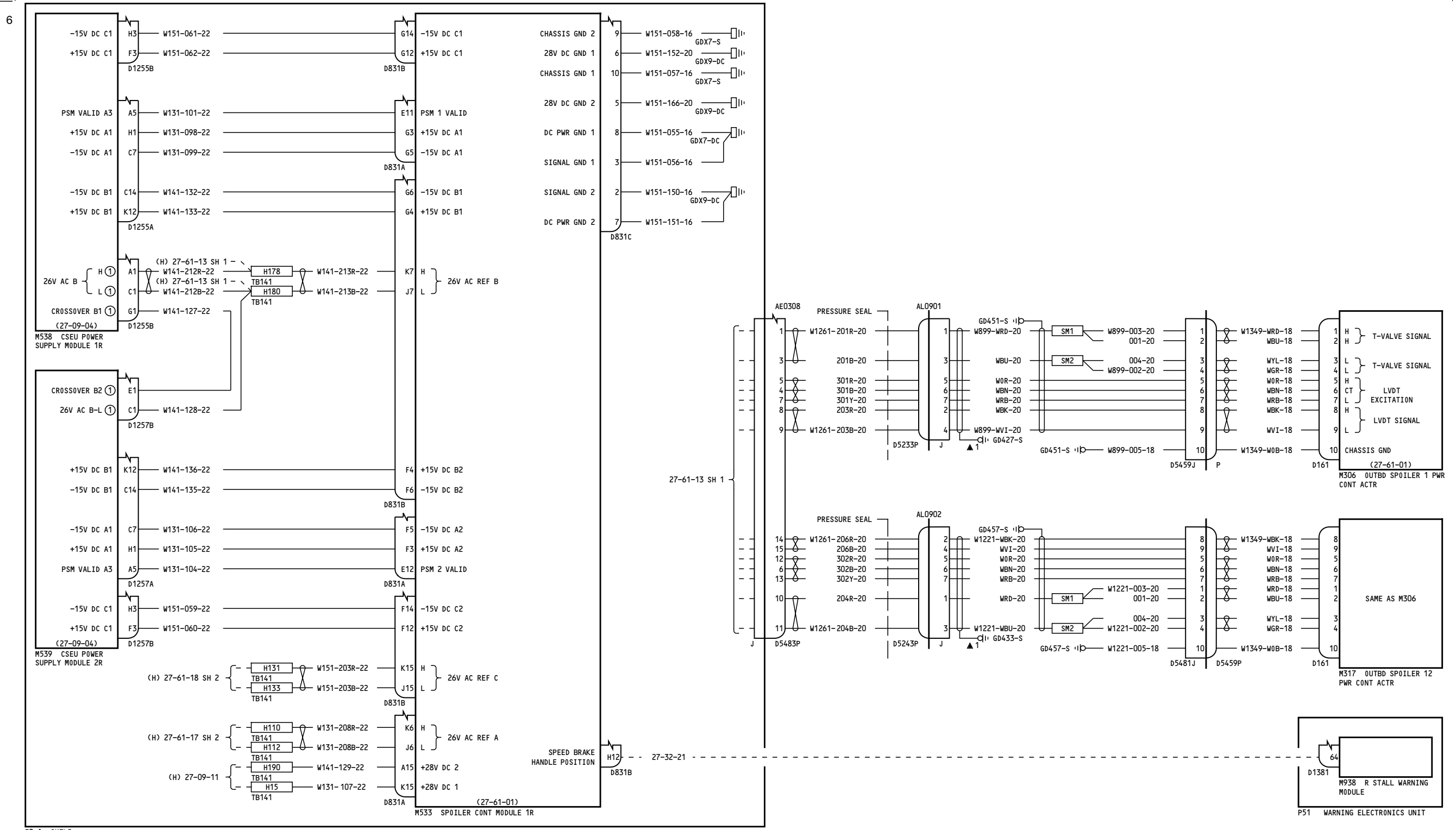

E2-1 SHELF  
NOTES:  
① 27-09-02

050-099, 150-199	<b>SPOILER CONTROL- SURFACE PANELS 1 &amp; 12</b>	<b>27-61-13</b>
	D280T132	Page 1 Sheet 2 Jan 21/2005

<b>27-61-13</b>
Page 1 Sheet 2 Jan 21/2005

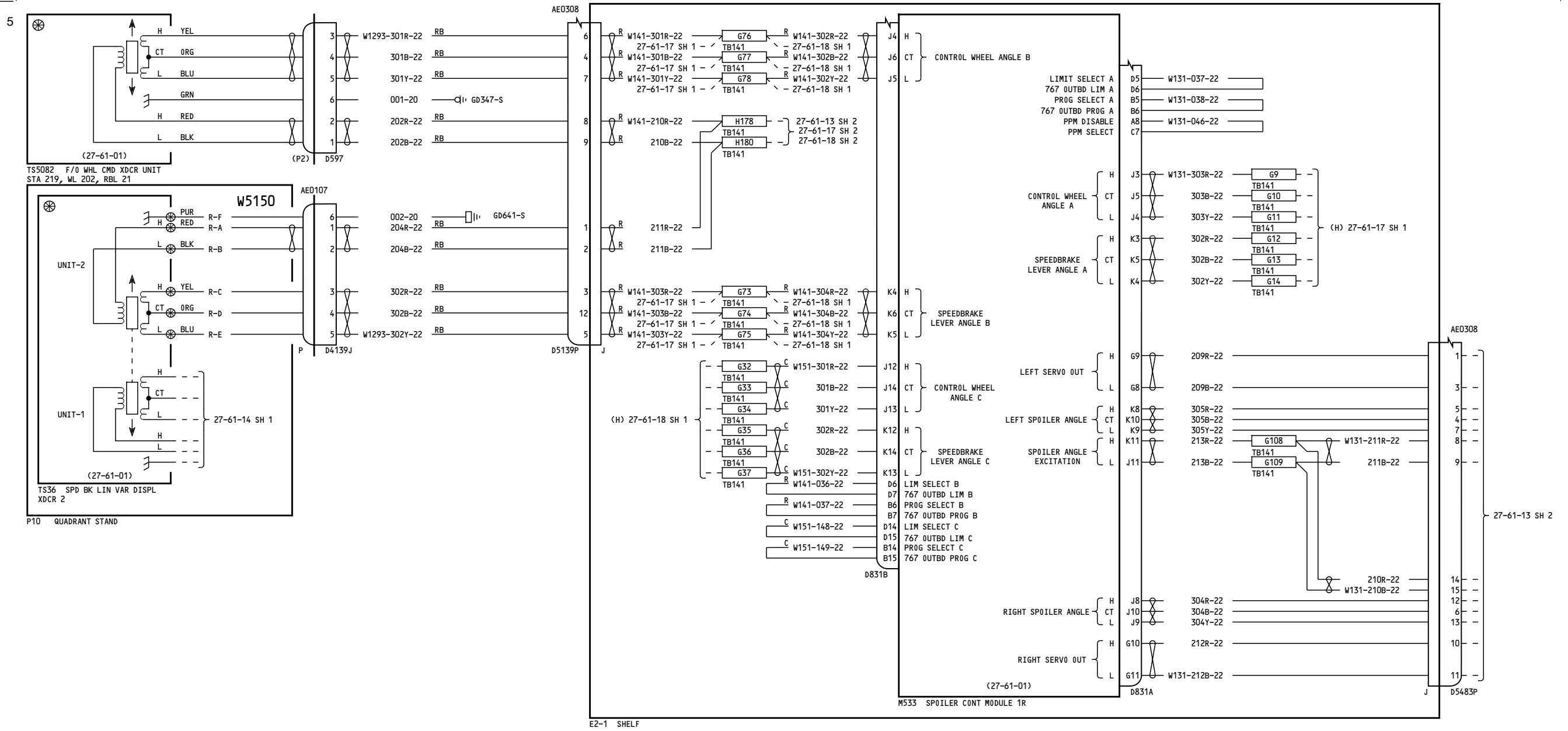

275-299

**SPOILER CONTROL-SURFACE PANELS 1 & 12**

**27-61-13**

Page 2  
Sheet 1  
Jan 21/2005

D280T132

**27-61-13**

Page 2  
Sheet 1  
Jan 21/2005



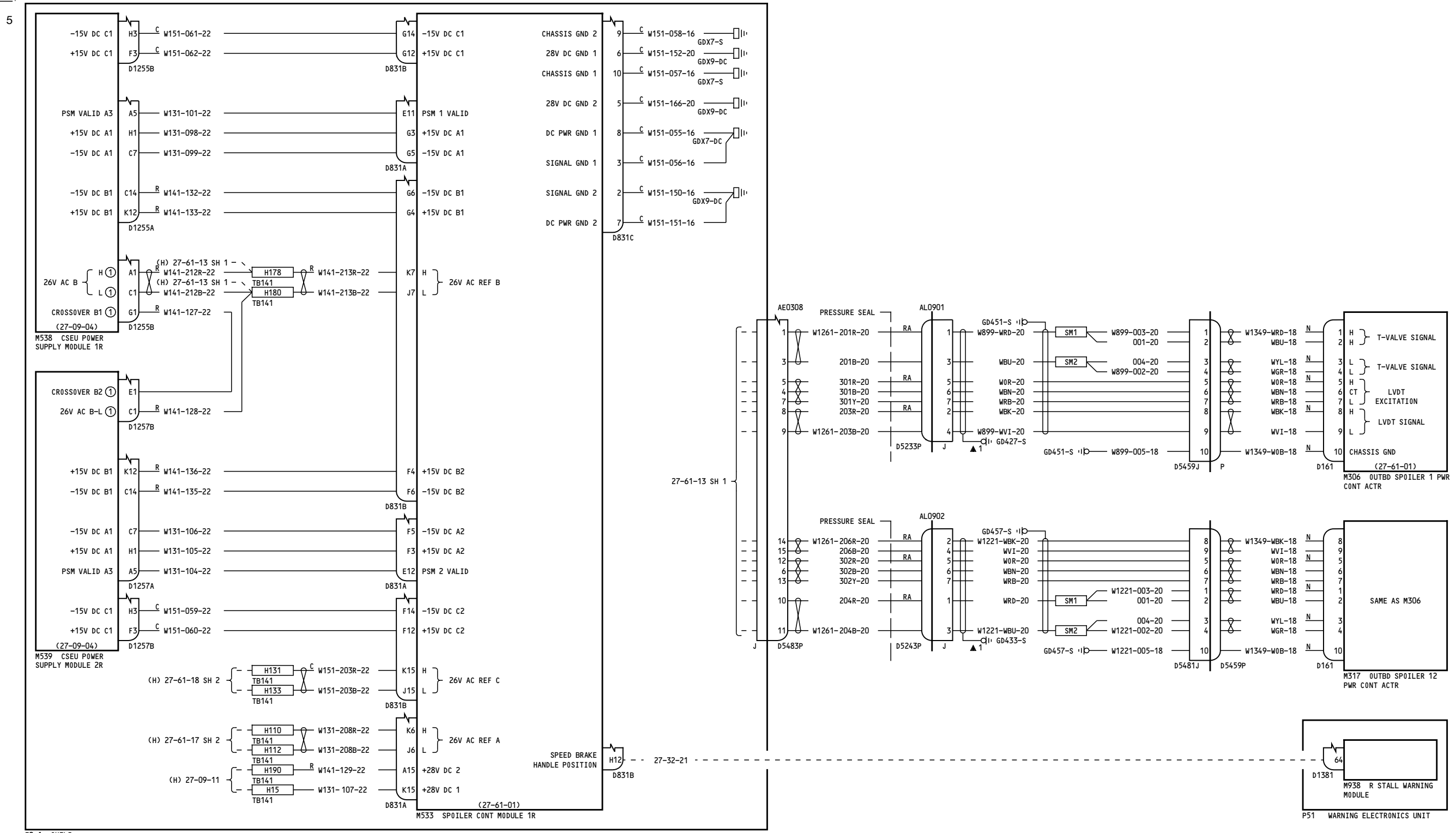

E2-1 SHELF  
 NOTES:  
 ① 27-09-02

275-299

**SPOILER CONTROL-  
 SURFACE PANELS 1 & 12**

D280T132

**27-61-13**

Page 2  
 Sheet 2  
 Jan 21/2005

**27-61-13**

Page 2  
 Sheet 2  
 Jan 21/2005

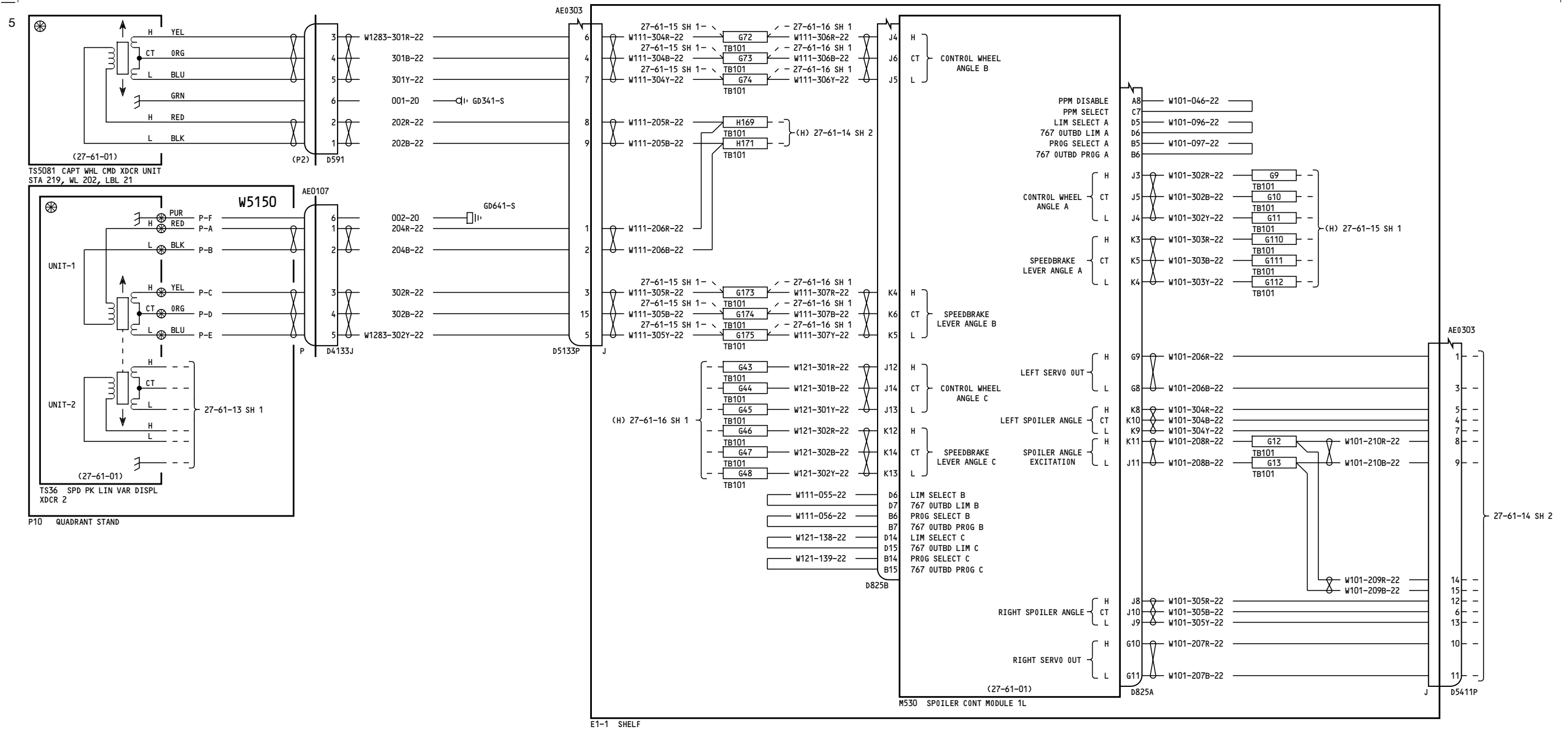

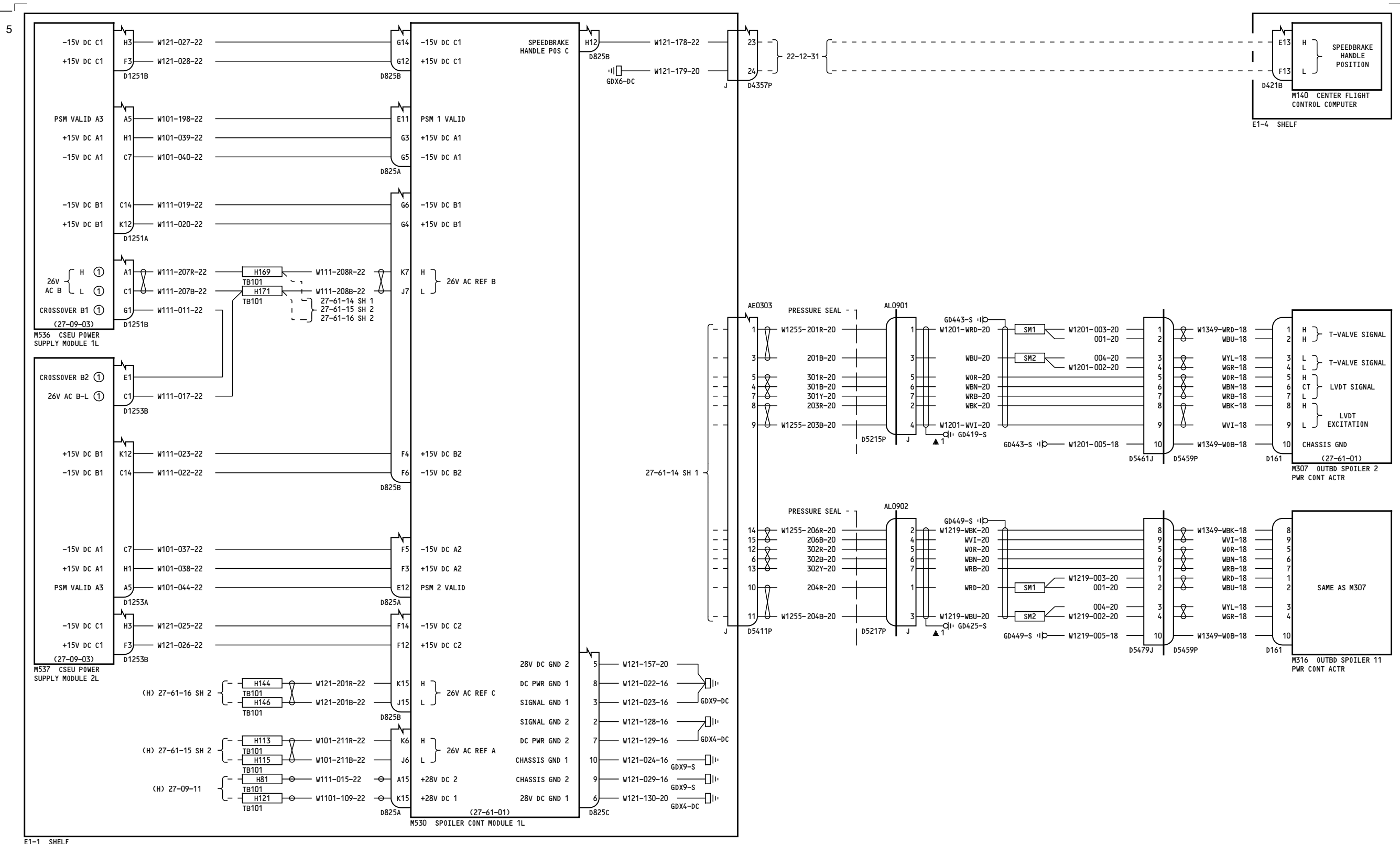

E1-1 SHELF  
NOTES: ① 27-09-02

050-099, 150-199

**SPOILER CONTROL-SURFACE PANELS 2 & 11**

**27-61-14**

Page 1  
Sheet 2  
Jan 21/2005

D280T132

**27-61-14**

Page 1  
Sheet 2  
Jan 21/2005

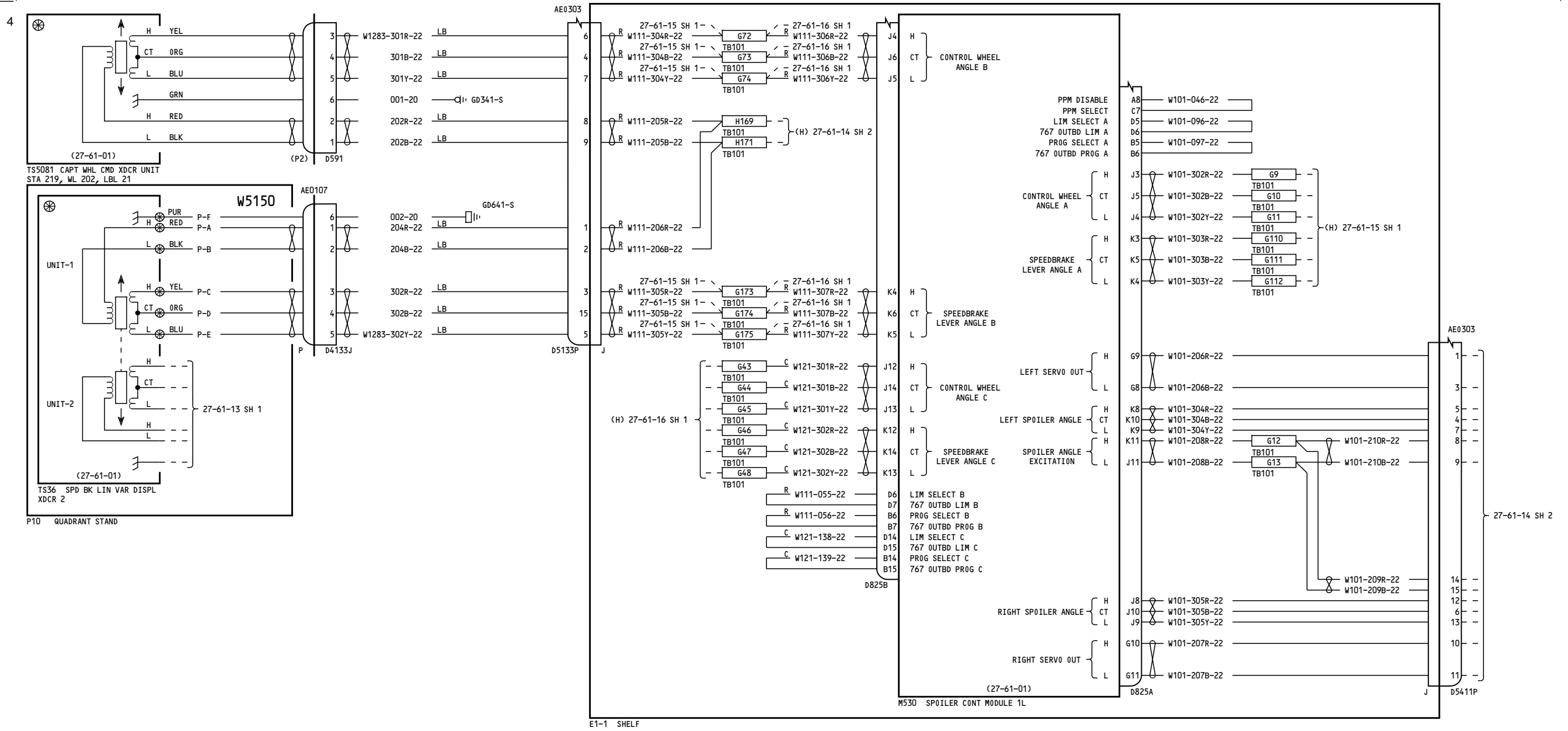

275-299

SPOILER CONTROL-SURFACE PANELS 2 & 11

27-61-14

Page 2  
Sheet 1  
Jan 21/2005

D280T132

27-61-14

Page 2  
Sheet 1  
Jan 21/2005

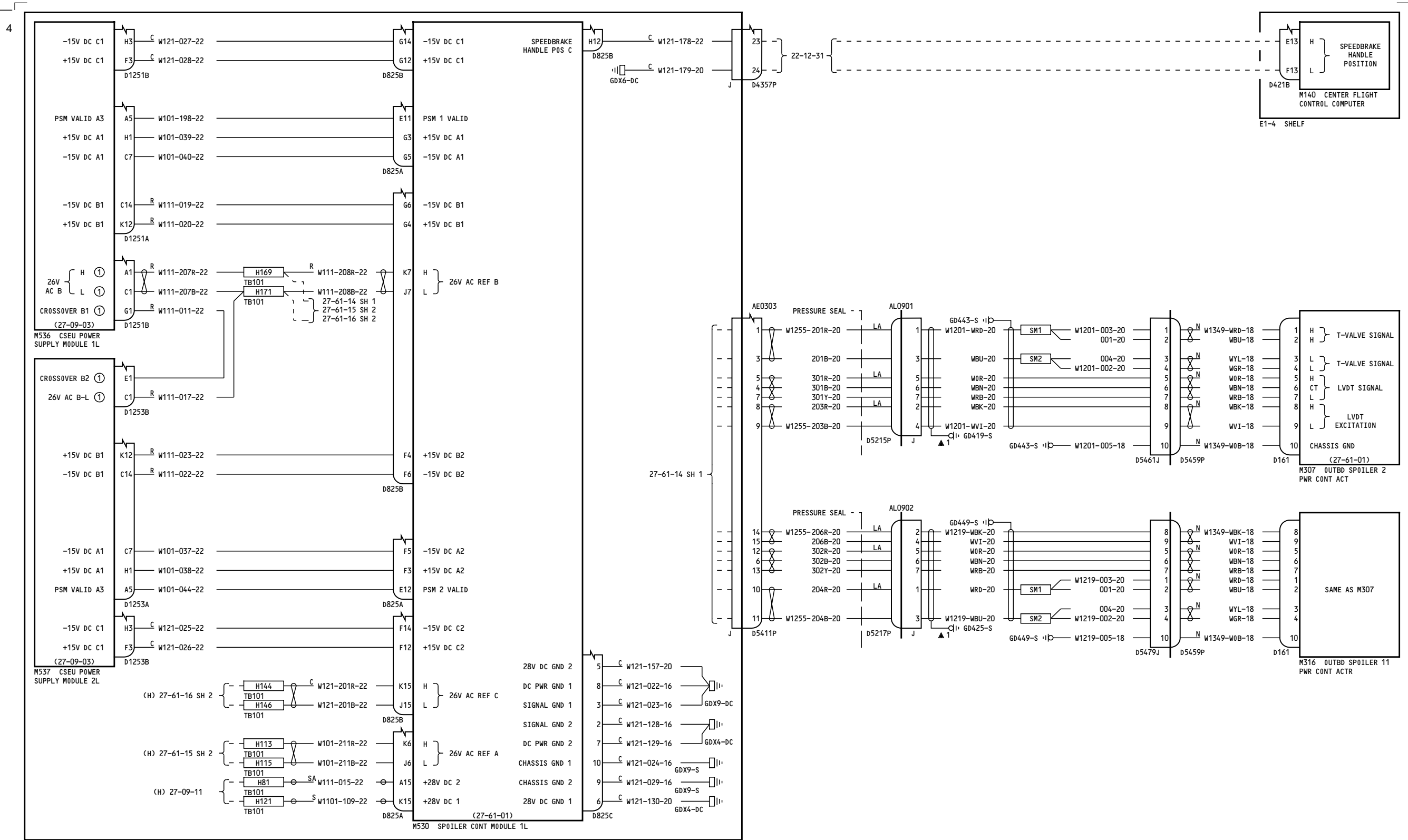

E1-1 SHELF  
NOTES: ① 27-09-02

275-299

SPOILER CONTROL-SURFACE PANELS 2 & 11

27-61-14

Page 2  
Sheet 2  
Jan 21/2005

D280T132

27-61-14

Page 2  
Sheet 2  
Jan 21/2005

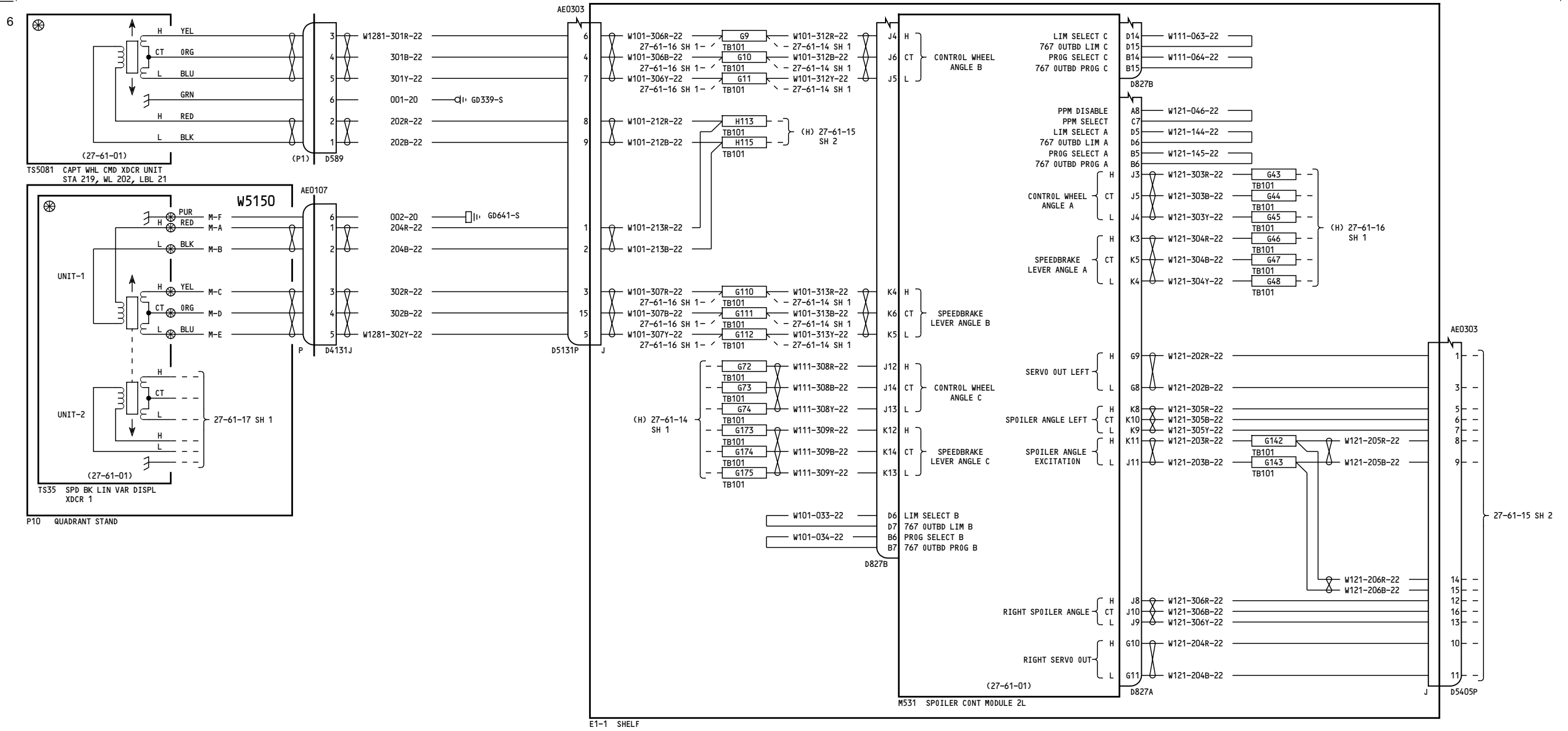

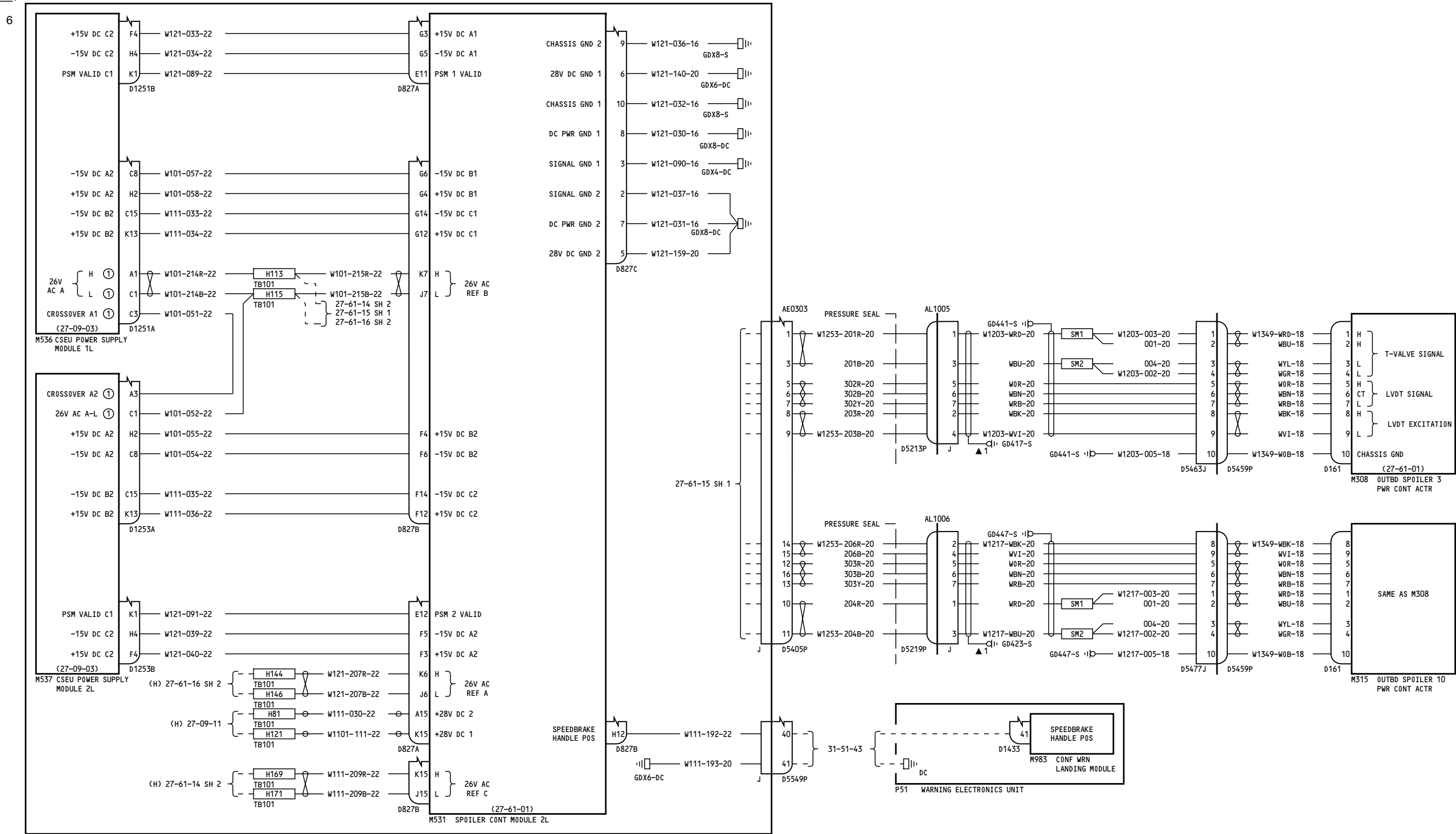

E1-1 SHELF

NOTES:  
 ① 27-09-01

050-099, 150-199	<p><b>SPOILER CONTROL-SURFACE PANELS 3 &amp; 10</b></p> <p><b>27-61-15</b></p> <p>Page 1 Sheet 2 Jan 21/2005</p> <p>D280T132</p>
------------------	--

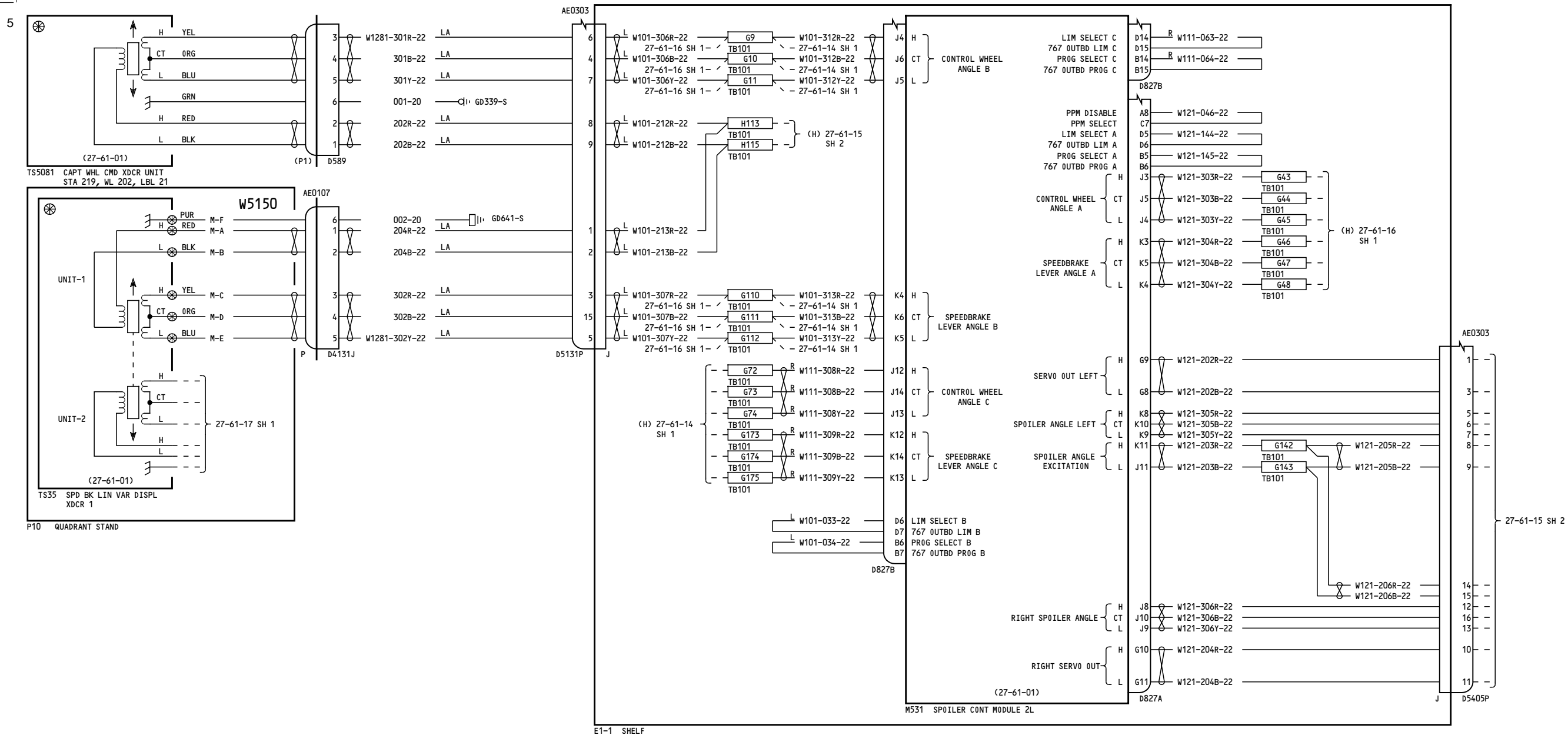



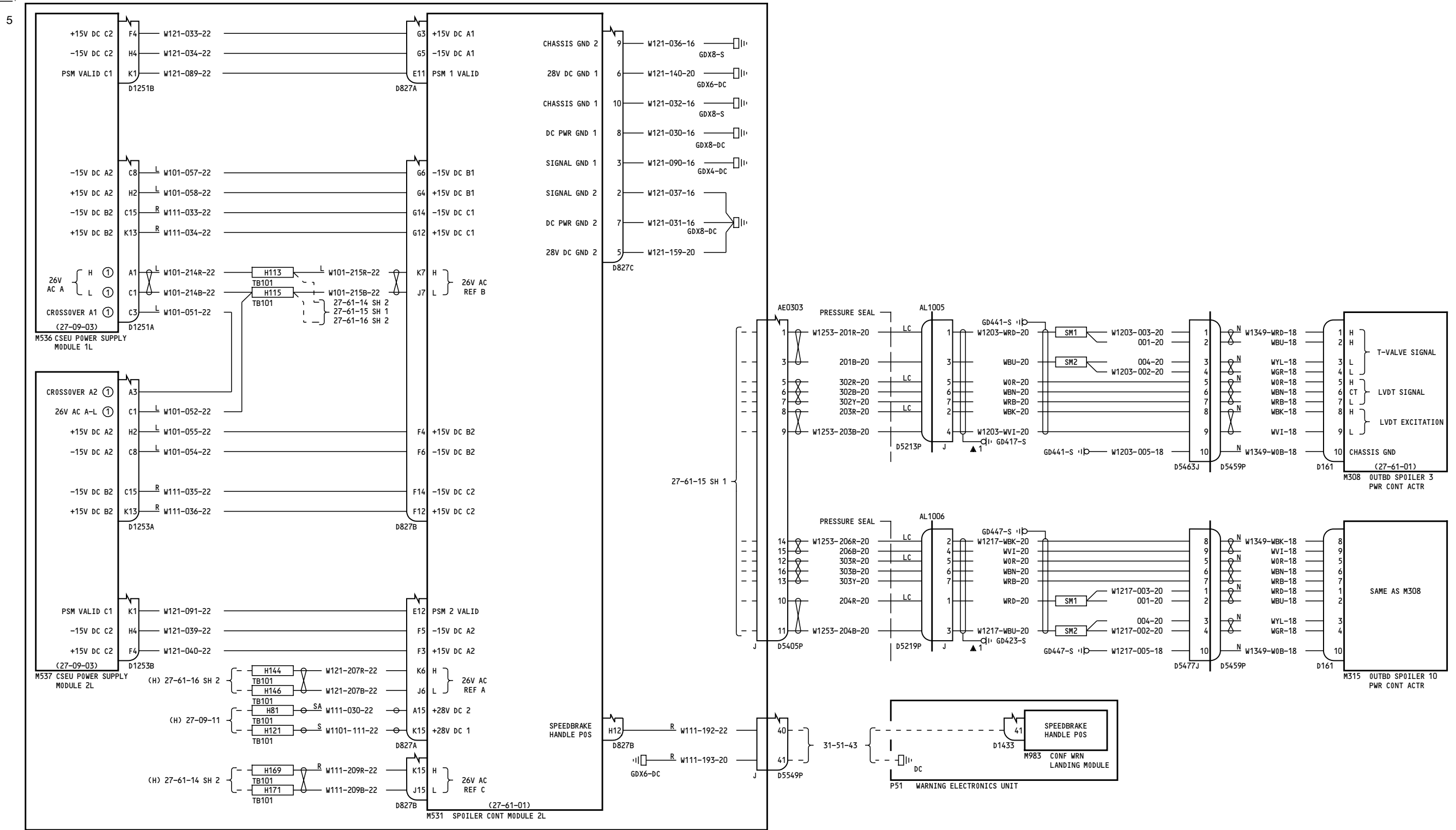

E1-1 SHELF

NOTES:  
① 27-09-01

275-299

**SPOILER CONTROL-SURFACE PANELS 3 & 10**

**27-61-15**

Page 2  
Sheet 2  
Jan 21/2005

D280T132

**27-61-15**

Page 2  
Sheet 2  
Jan 21/2005

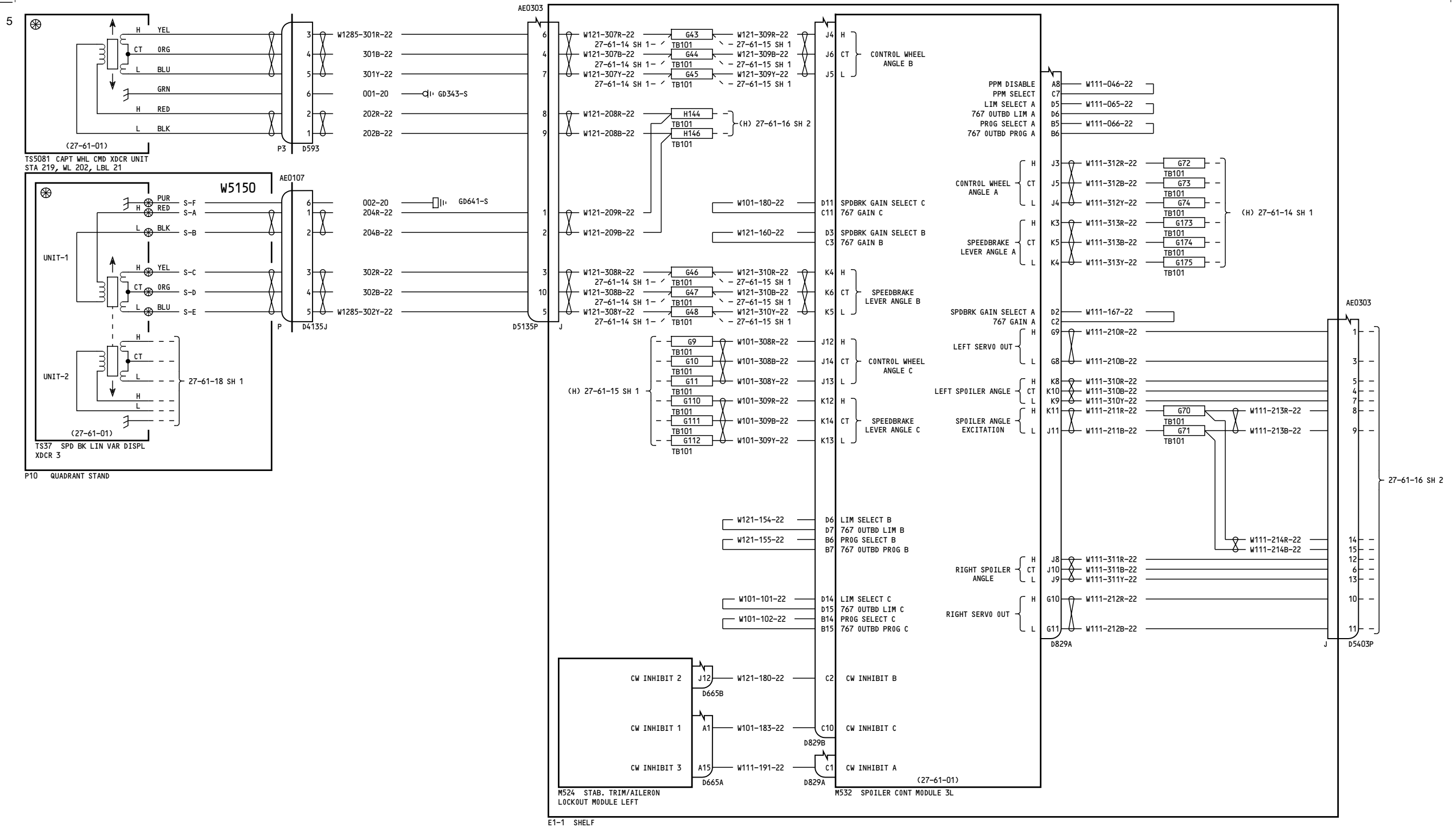

050-099, 150-199

SPOILER CONTROL-SURFACE PANELS 4 & 9

27-61-16

Page 1  
Sheet 1  
Jan 21/2005

D280T132

27-61-16

Page 1  
Sheet 1  
Jan 21/2005

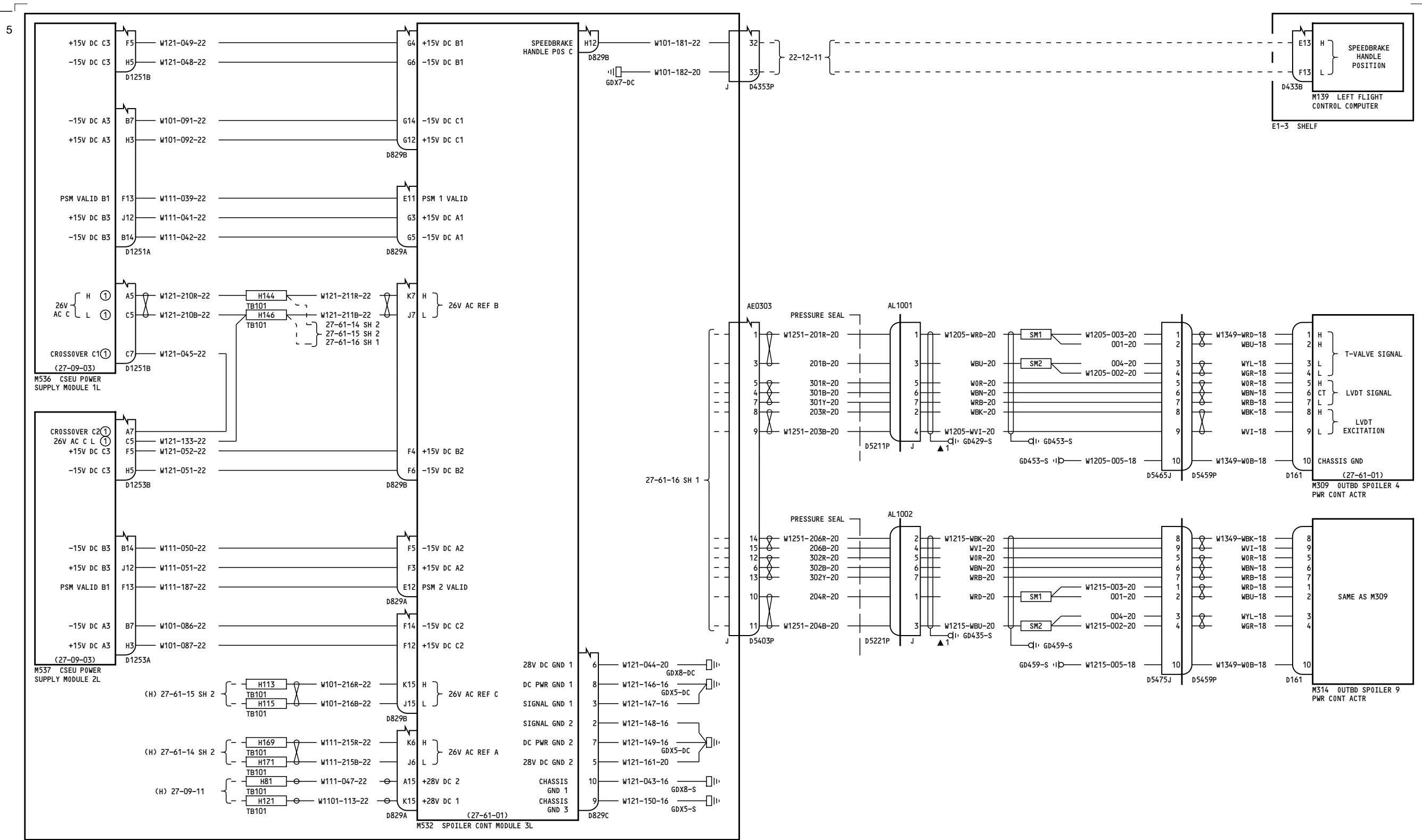

E1-1 SHELF  
NOTES:  
① 27-09-01

050-099, 150-199

**SPOILER CONTROL-SURFACE PANELS 4 & 9**  
**27-61-16**  
Page 1  
Sheet 2  
Jan 21/2005  
D280T132

**27-61-16**

Page 1  
Sheet 2  
Jan 21/2005

**27-61-16**

Page 1  
Sheet 2  
Jan 21/2005

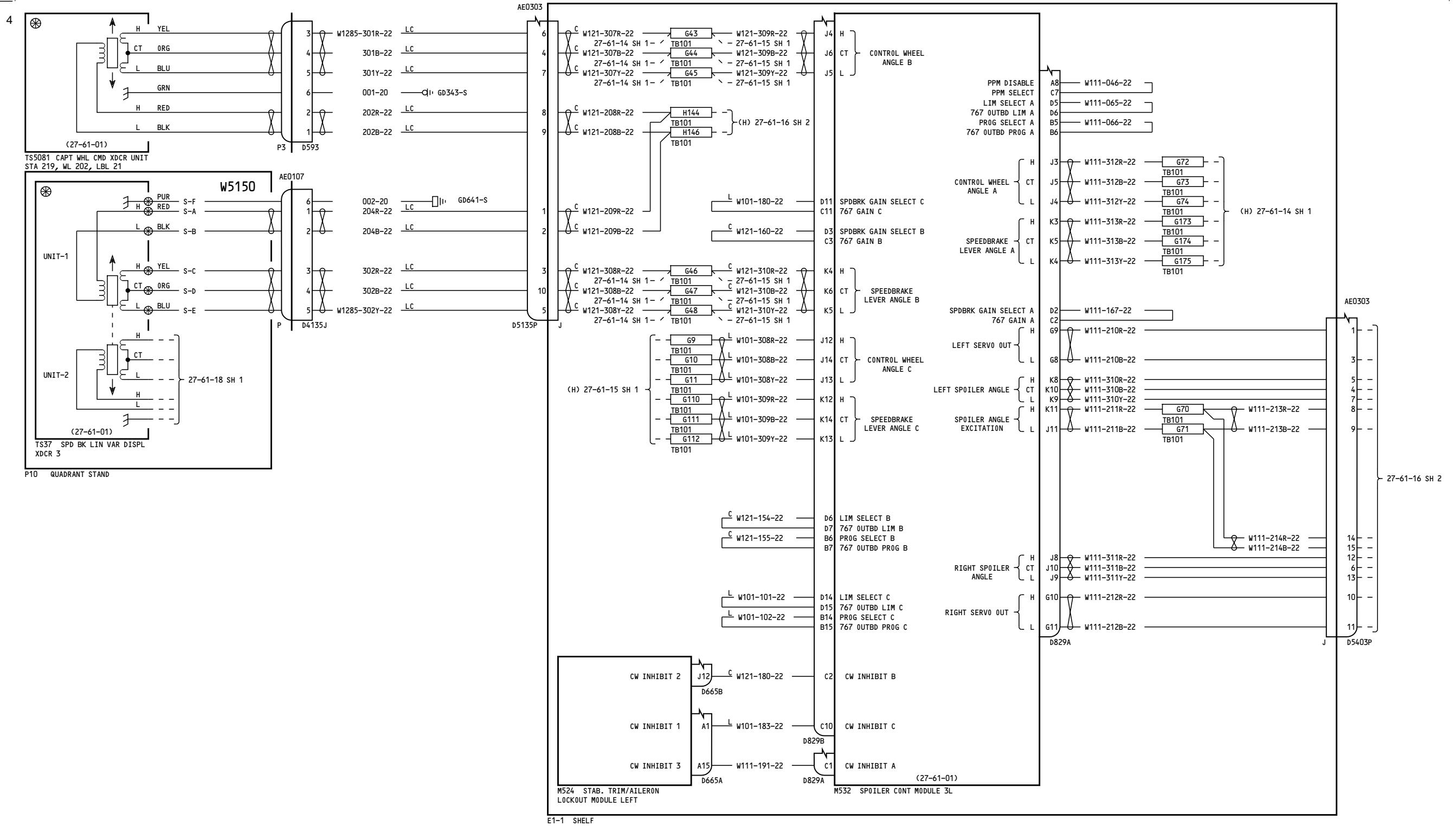

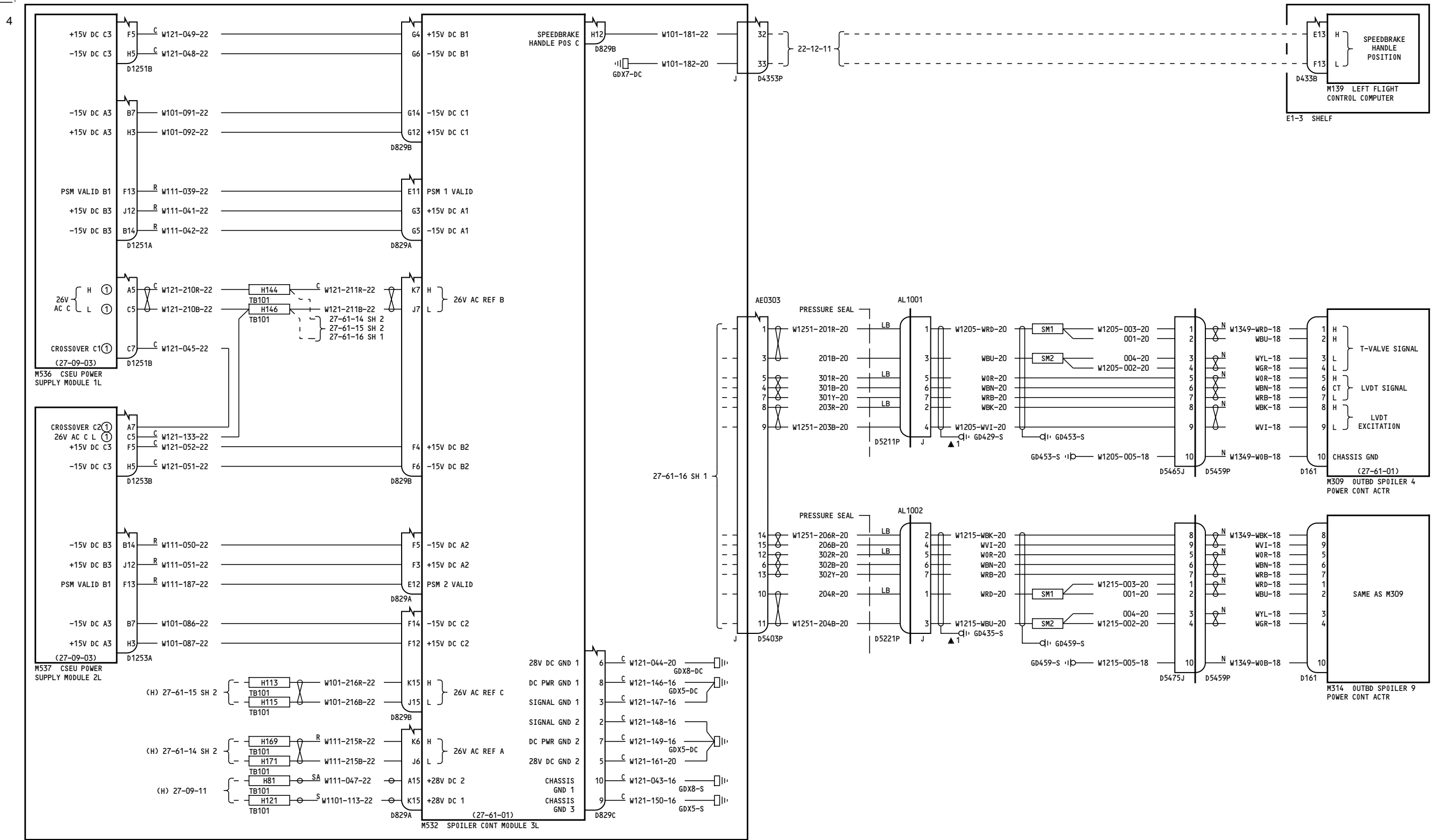

E1-1 SHELF  
 NOTES: ① 27-09-01

275-299

**SPOILER CONTROL-SURFACE PANELS 4 & 9**  
**27-61-16**  
 Page 2  
 Sheet 2  
 Jan 21/2005  
 D280T132

**27-61-16**  
 Page 2  
 Sheet 2  
 Jan 21/2005

**27-61-16**  
 Page 2  
 Sheet 2  
 Jan 21/2005

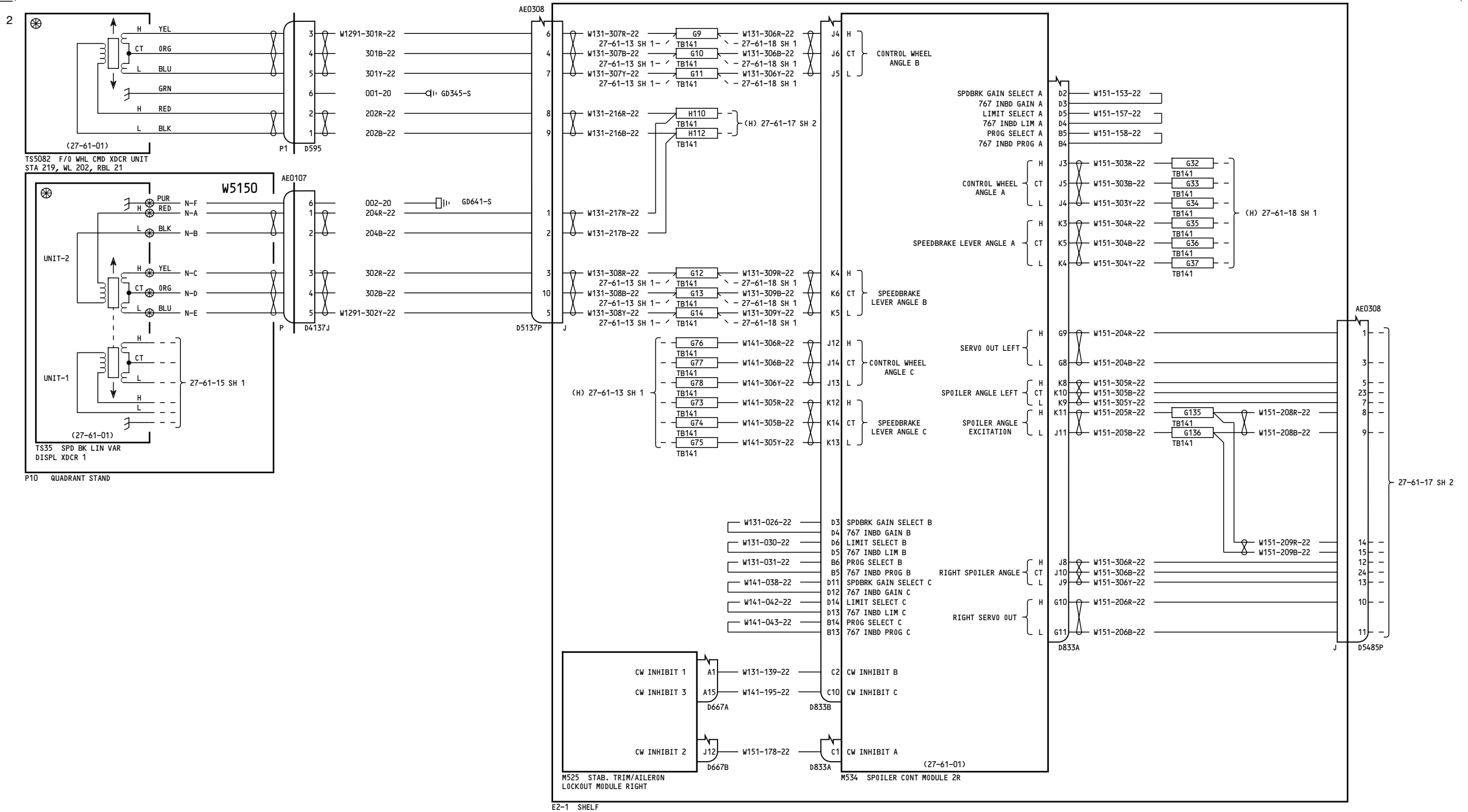

050-099, 150-157

**SPOILER CONTROL-SURFACE PANELS 5 & 8**

**27-61-17**

Page 1  
Sheet 1  
Jan 21/2005

D280T132

**27-61-17**

Page 1  
Sheet 1  
Jan 21/2005

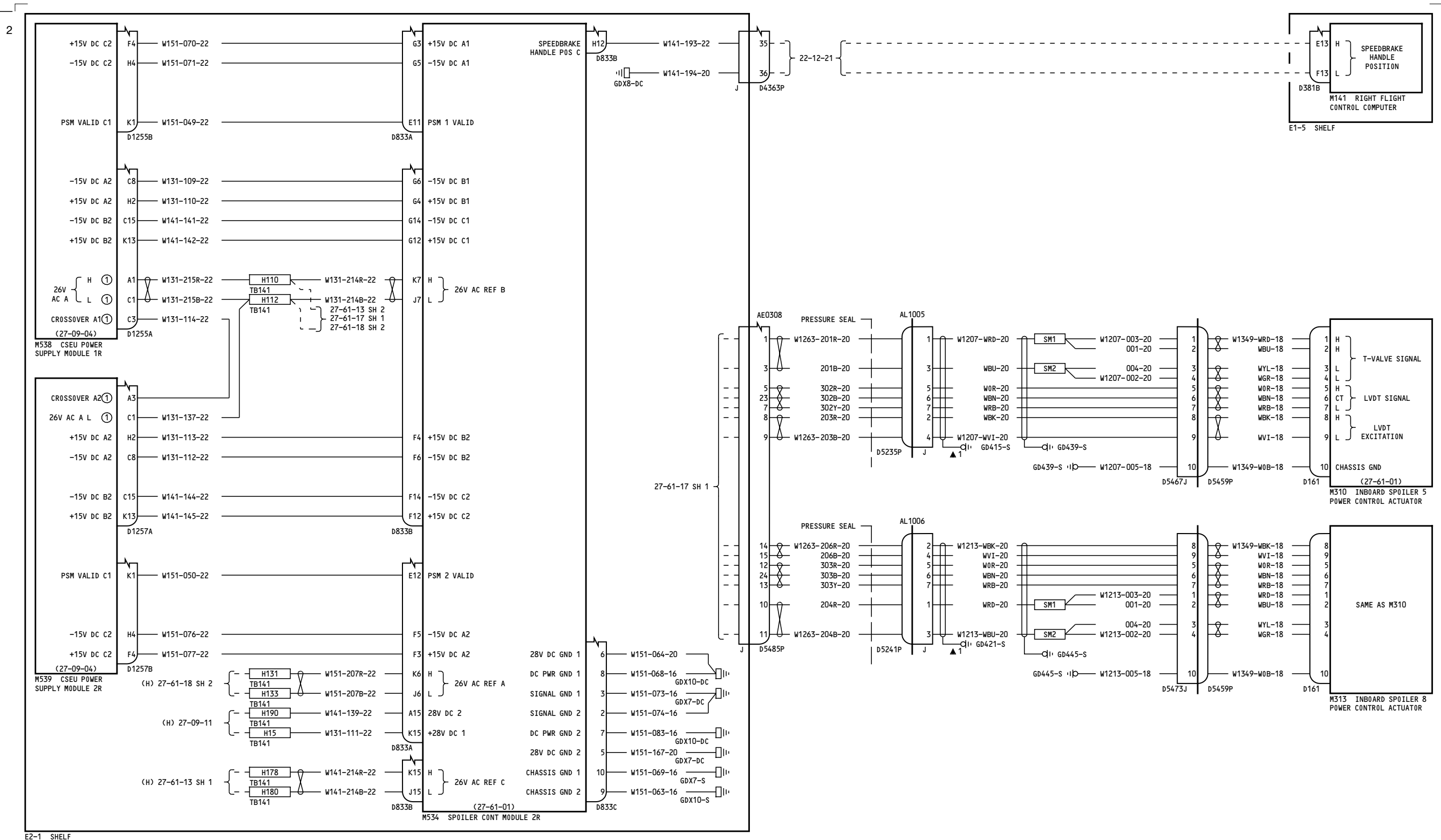

NOTES:

① 27-09-02

050-099, 150-157

**SPOILER CONTROL-SURFACE PANELS 5 & 8**

D280T132

**27-61-17**

Page 1  
Sheet 2  
Jan 21/2005

**27-61-17**

Page 1  
Sheet 2  
Jan 21/2005

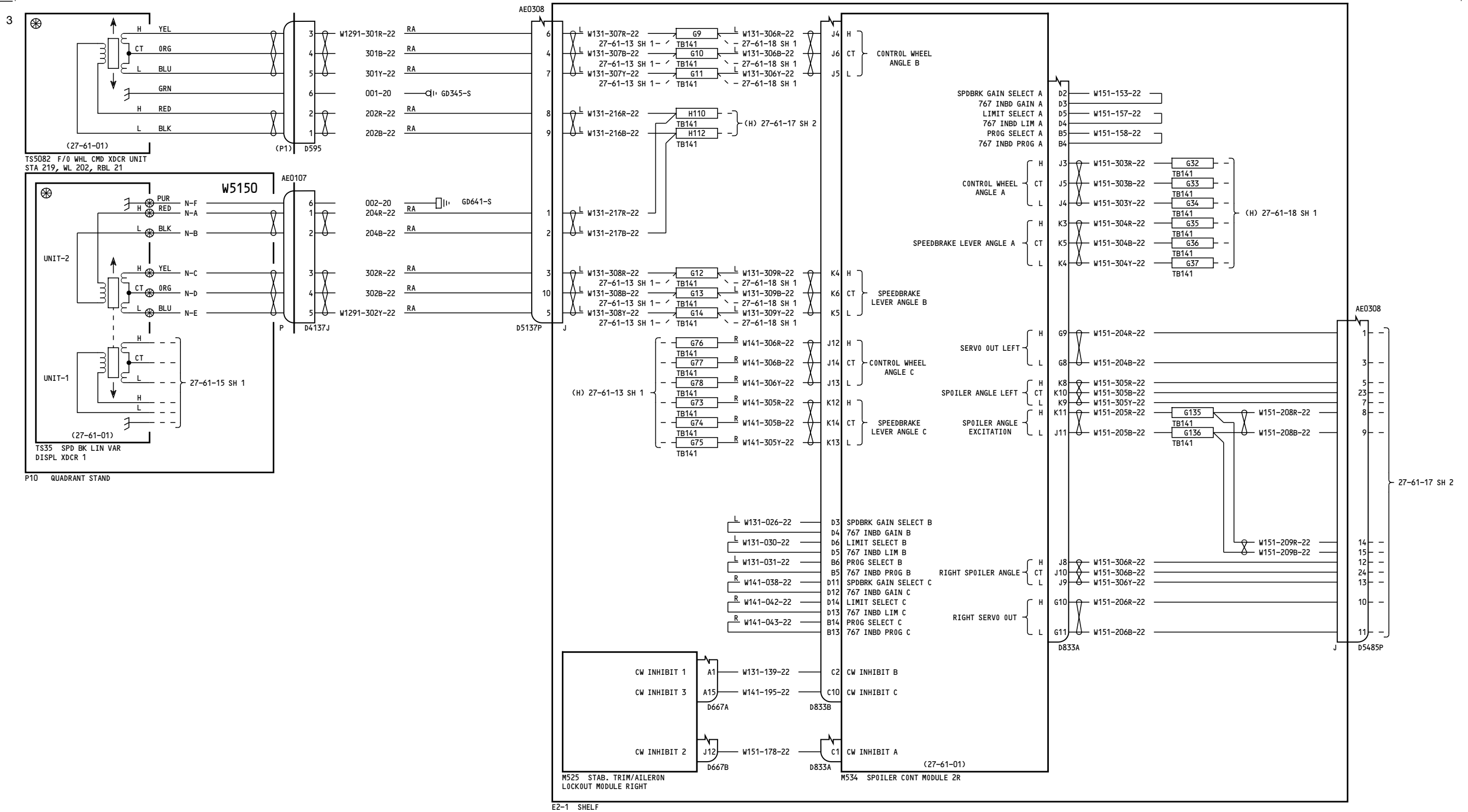

162-199, 275-299

**SPOILER CONTROL-SURFACE PANELS 5 & 8**

**27-61-17**

Page 2  
Sheet 1  
Jan 21/2005

D280T132

**27-61-17**

Page 2  
Sheet 1  
Jan 21/2005



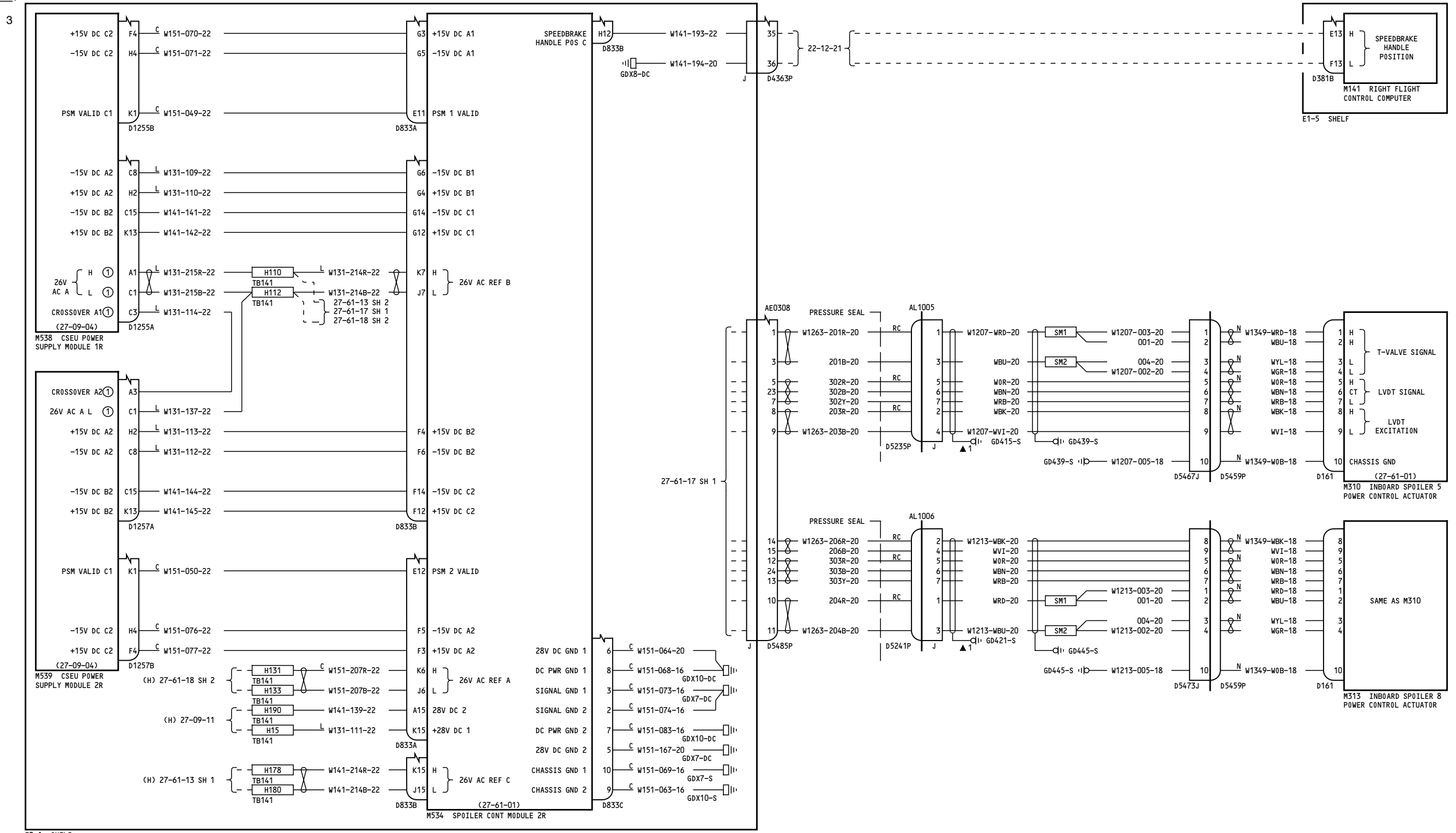

NOTES:

① 27-09-02

162-199, 275-299

**SPOILER CONTROL-SURFACE PANELS 5 & 8**

**27-61-17**

Page 2  
Sheet 2  
Jan 21/2005

D280T132

**27-61-17**

Page 2  
Sheet 2  
Jan 21/2005

**27-61-17**

Page 2  
Sheet 2  
Jan 21/2005

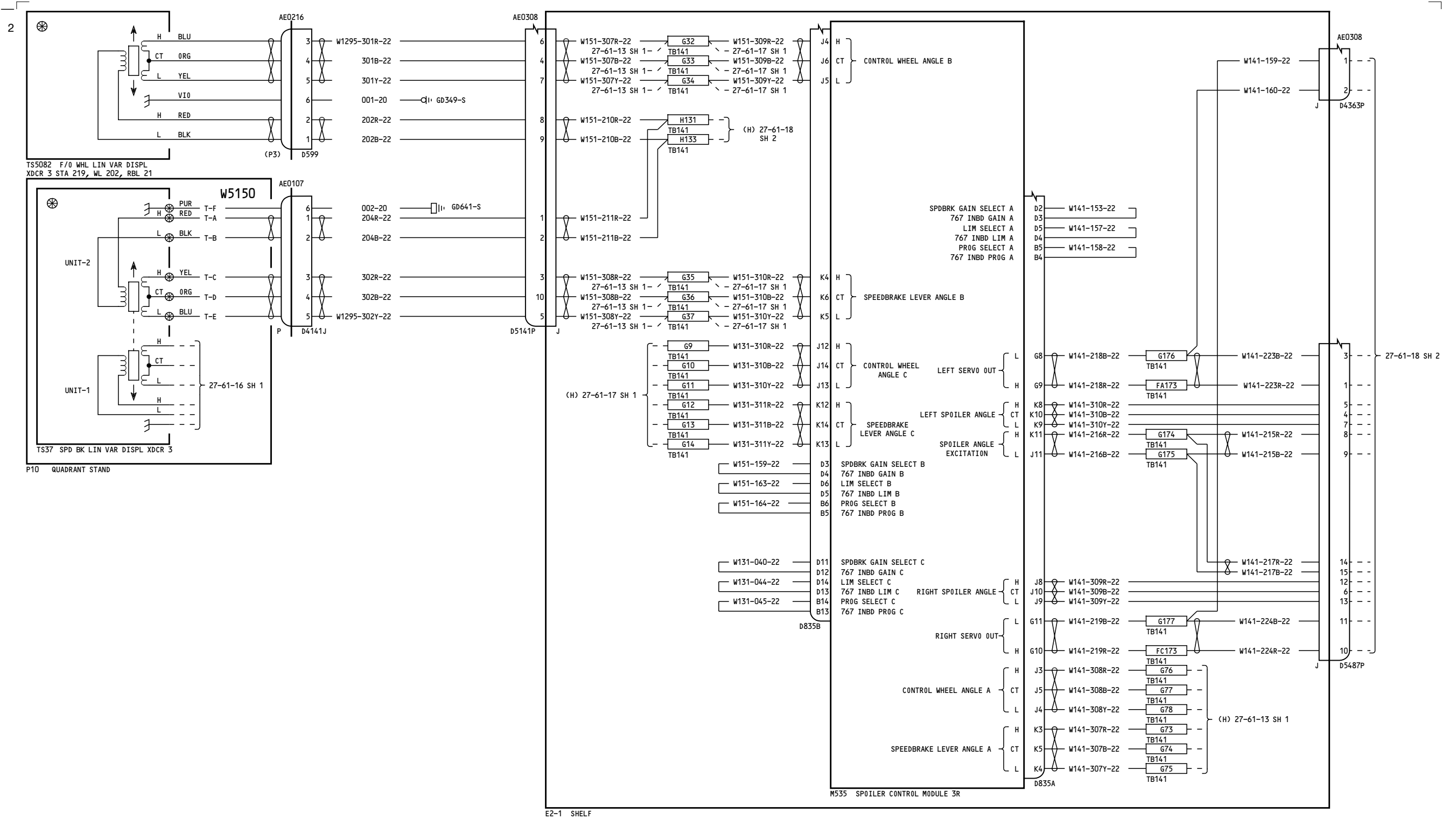

050-099

**SPOILER CONTROL-  
SURFACE PANELS 6 & 7**

**27-61-18**

Page 1  
Sheet 1  
Jan 21/2005

D280T132

**27-61-18**

Page 1  
Sheet 1  
Jan 21/2005

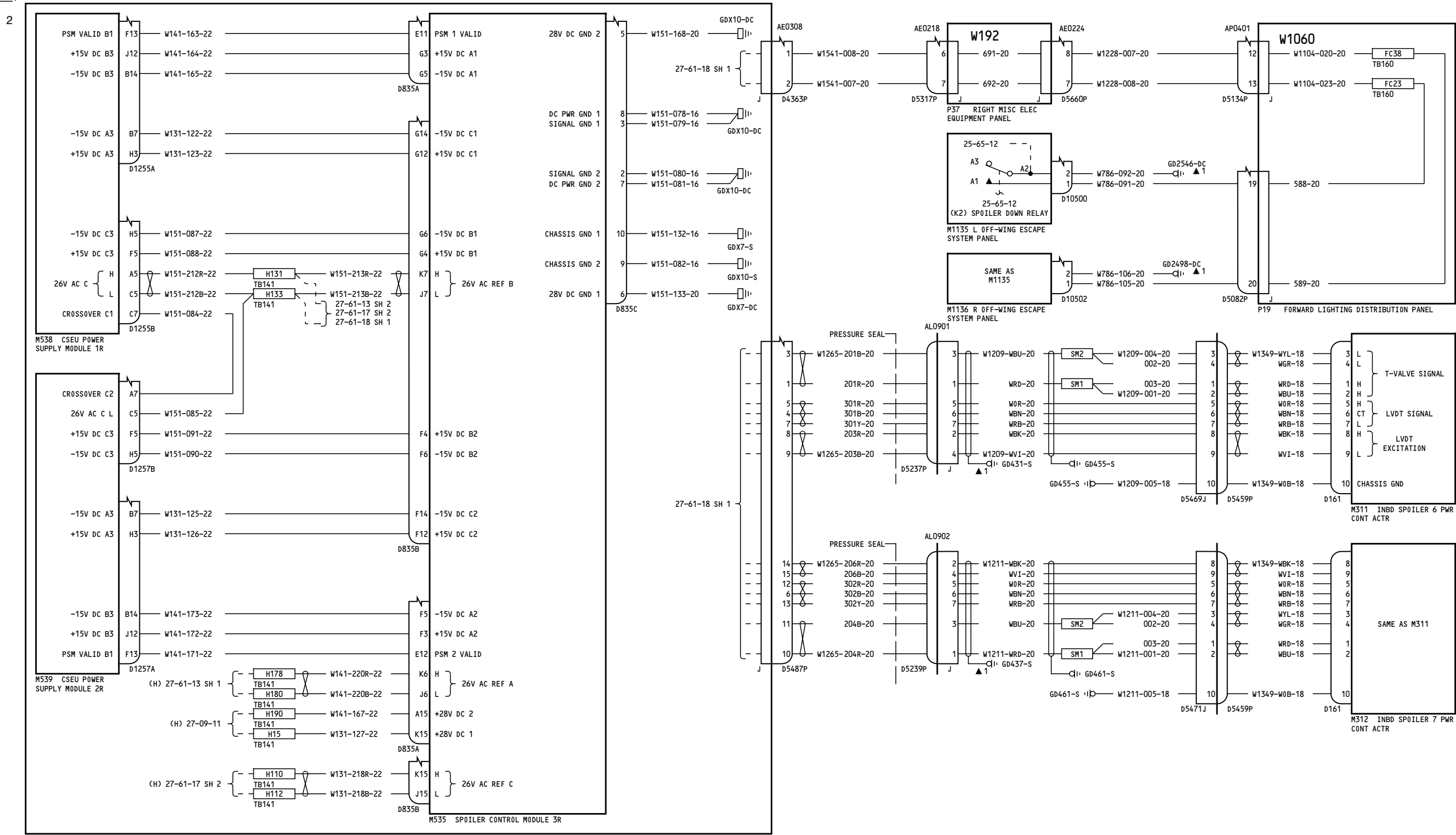

E2-1 SHELF

050-099

**SPOILER CONTROL-  
SURFACE PANELS 6 & 7**

D280T132

27-61-18

Page 1  
Sheet 2  
Jan 21/2005

27-61-18

Page 1  
Sheet 2  
Jan 21/2005

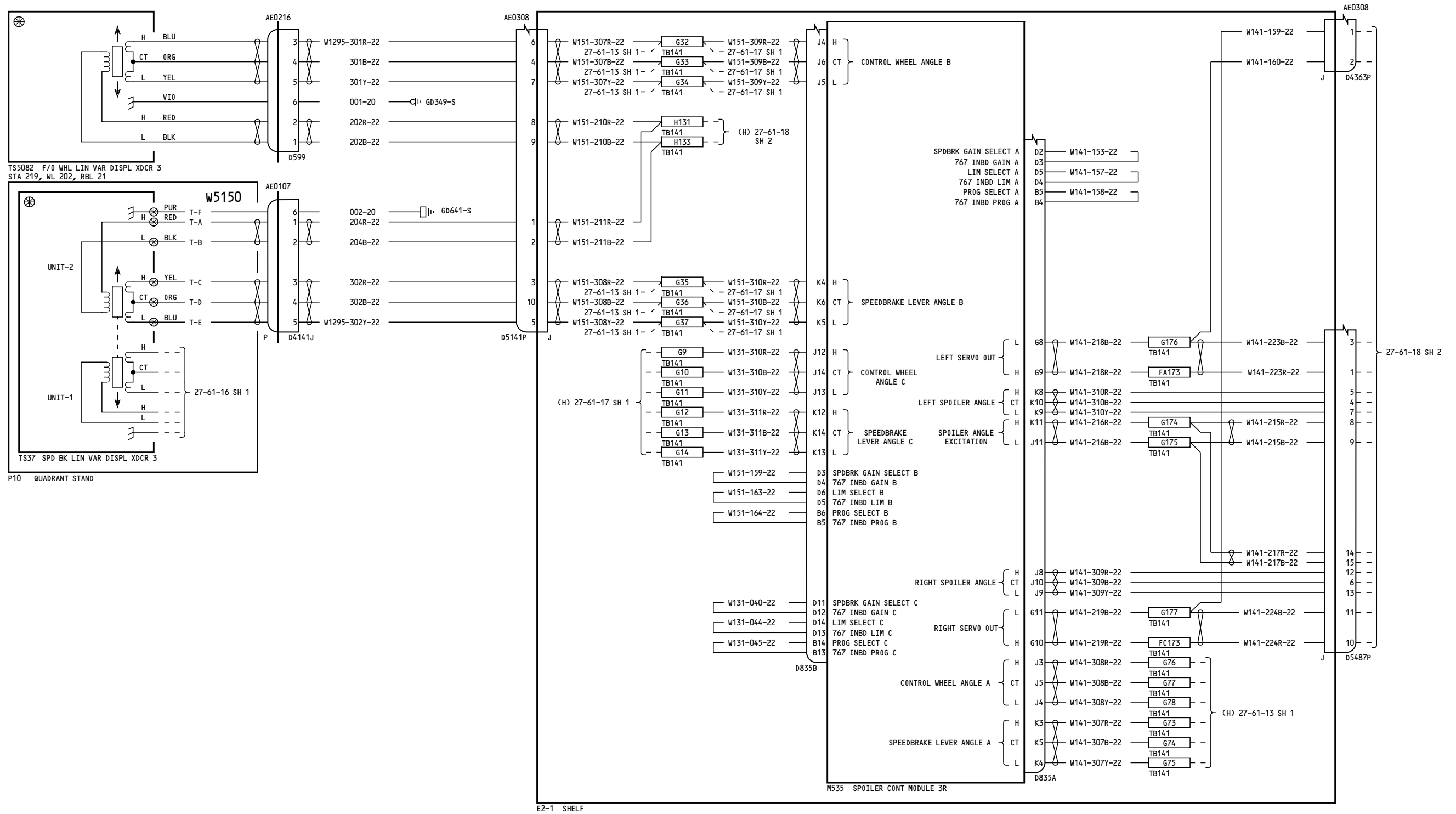

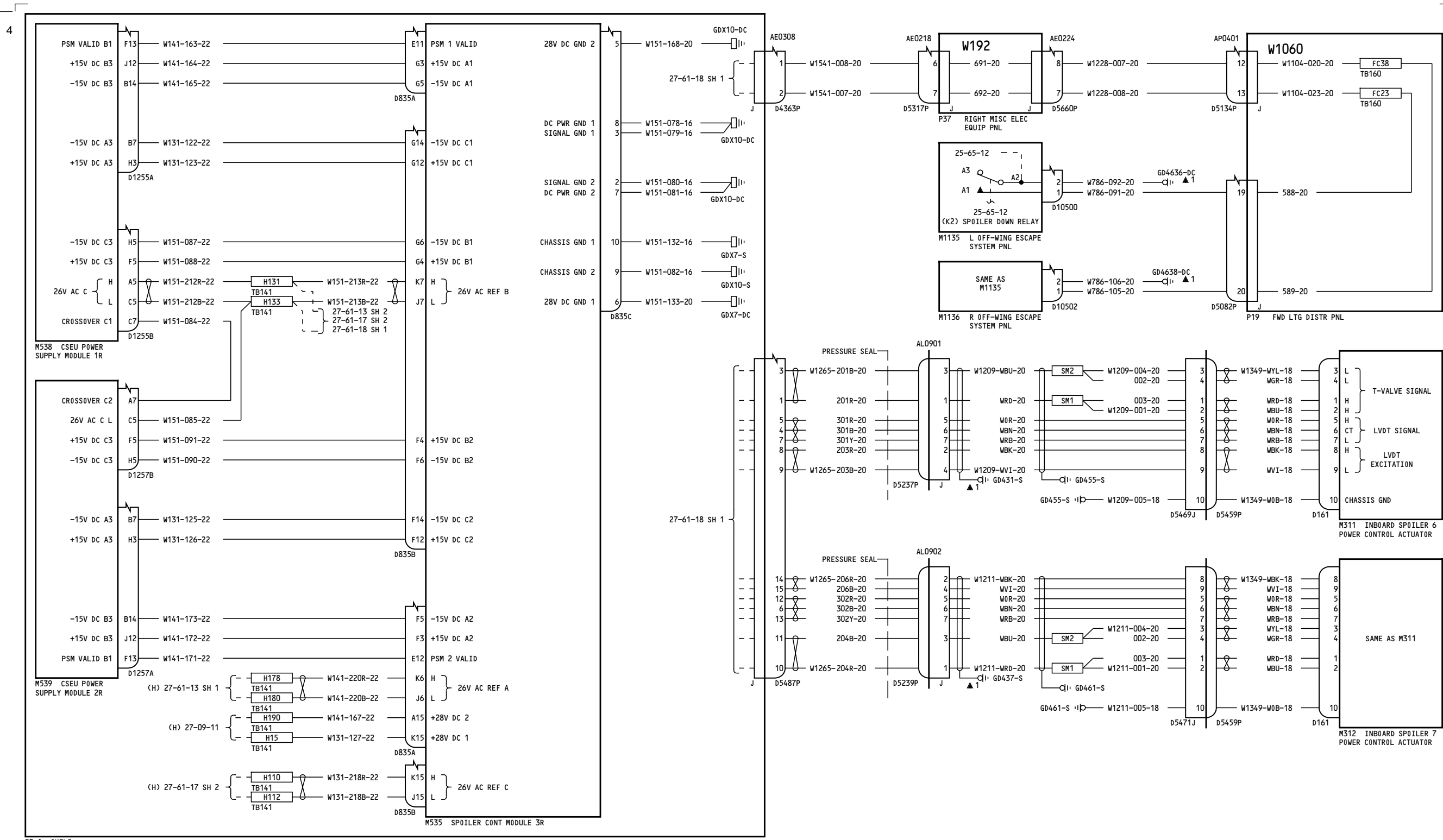

E2-1 SHELF

150-199, 275-299	<p><b>SPOILER CONTROL- SURFACE PANELS 6 &amp; 7</b></p> <p>D280T132</p>
------------------	---

**27-61-18**

Page 2  
Sheet 2  
Jan 21/2005

**27-61-18**

Page 2  
Sheet 2  
Jan 21/2005

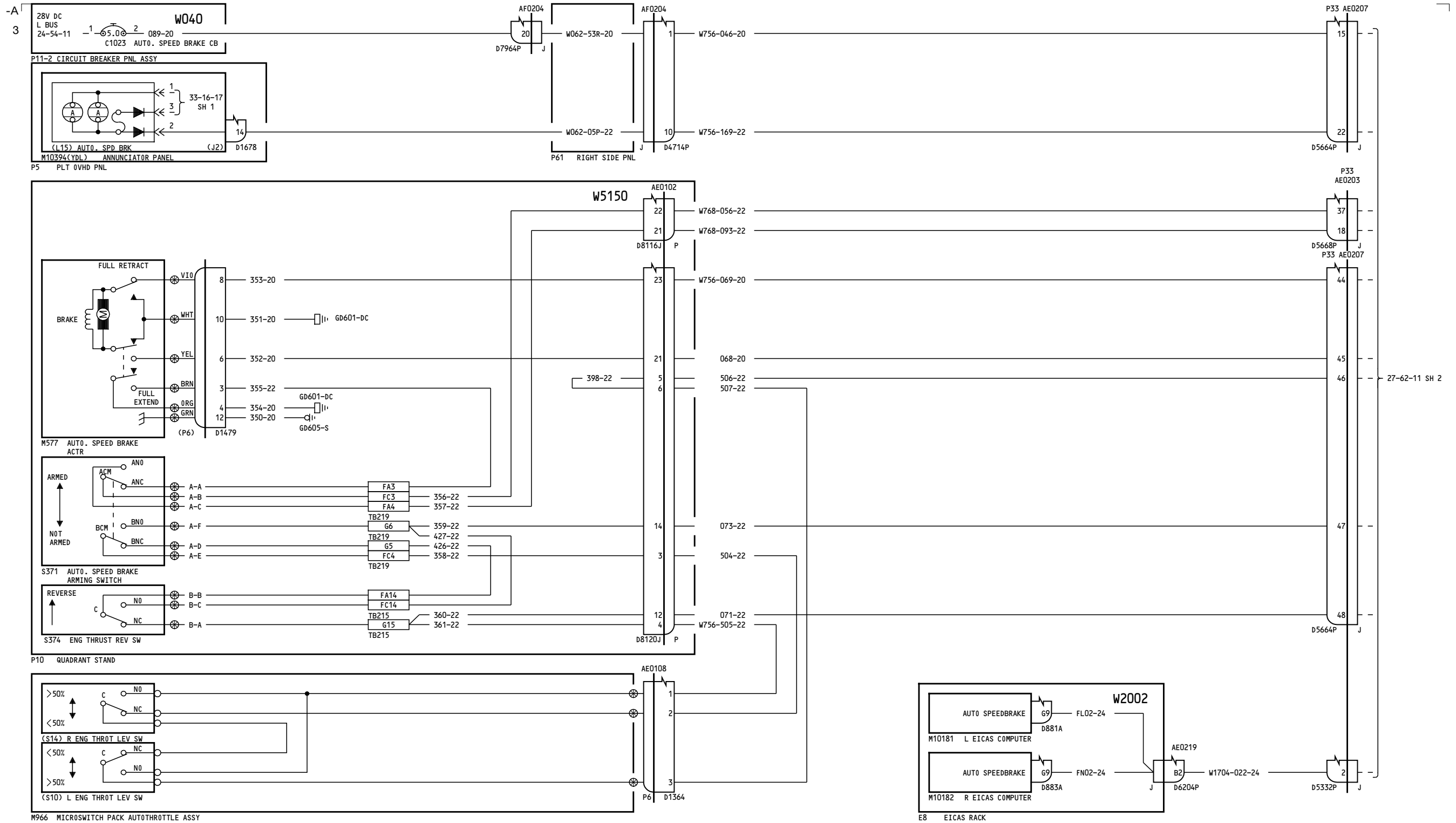

050

**AUTOMATIC SPEED BRAKE SYSTEM**

D280T132

**27-62-11**

Page 1.1  
Sheet 1  
Feb 06/2009

**27-62-11**

Page 1.1  
Sheet 1  
Feb 06/2009

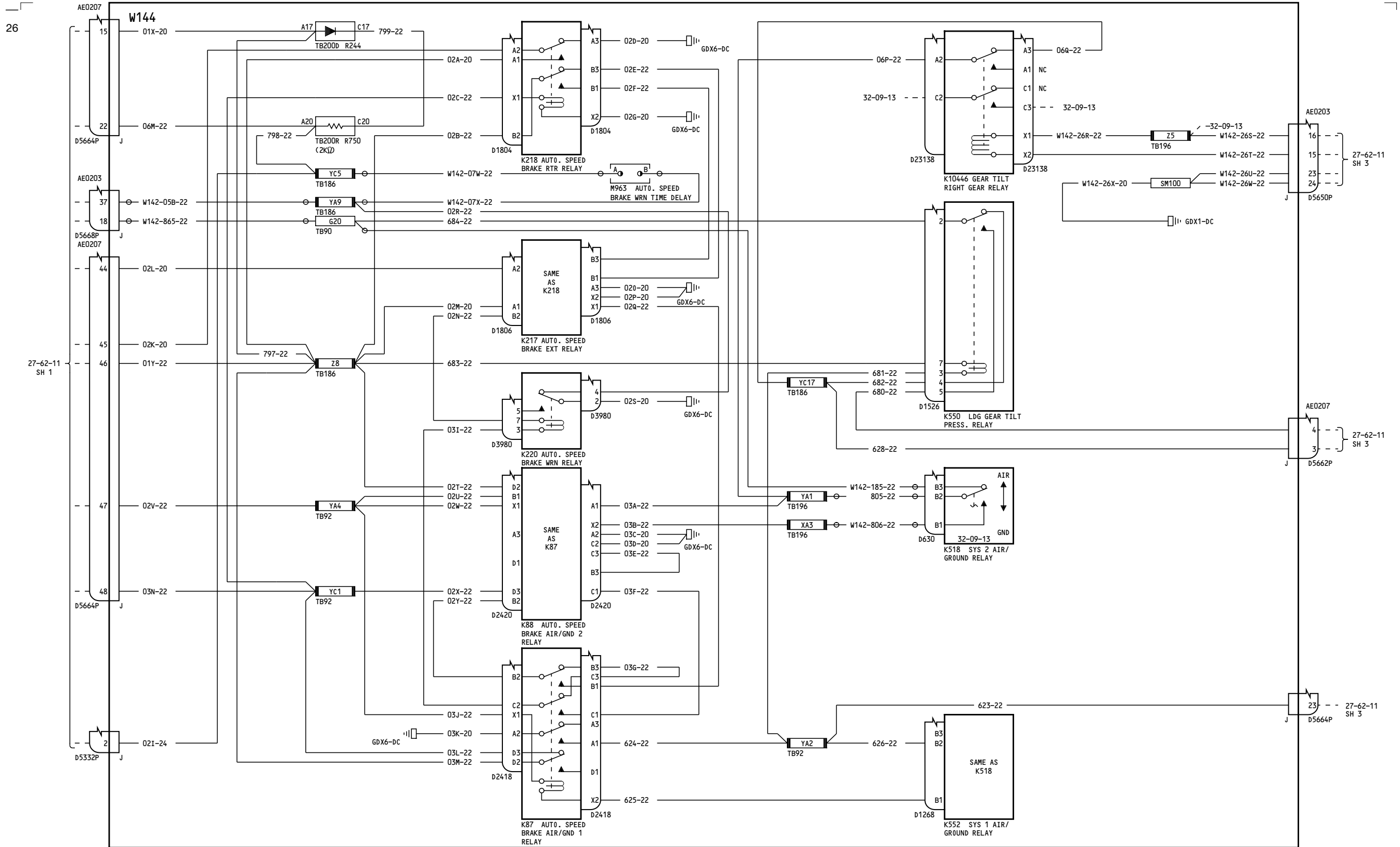

050

P33 FWD MISC. ELEC. EQUIP. PNL

**AUTOMATIC SPEED BRAKE SYSTEM**

**27-62-11**

Page 1.1  
Sheet 2  
Aug 15/2007

D280T132

Incorporates  
27A0160

**27-62-11**

Page 1.1  
Sheet 2  
Aug 15/2007

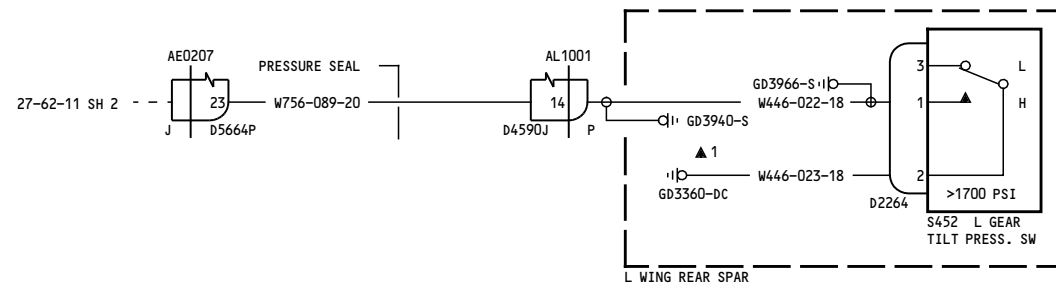
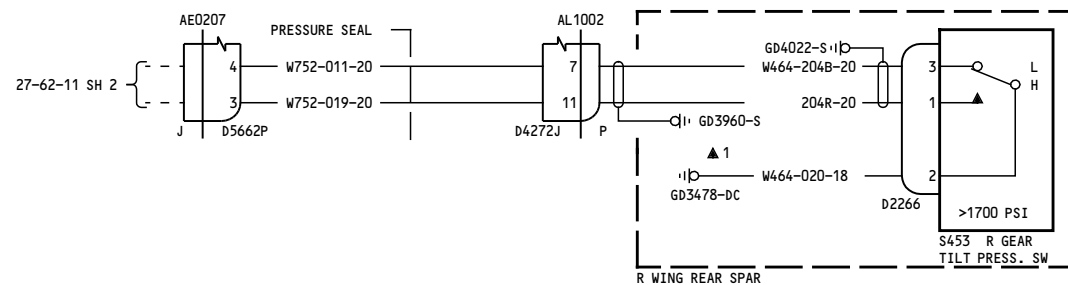
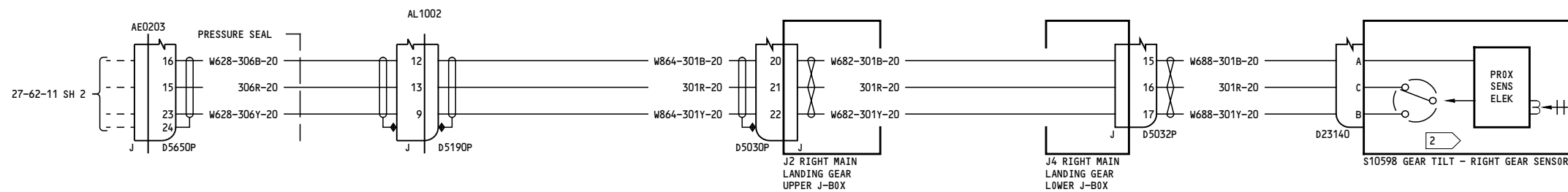

2 A "1" = GEAR TILT

050

**AUTOMATIC SPEED BRAKE SYSTEM**

D280T132

**27-62-11**

Page 1.1  
Sheet 3  
Aug 15/2007

Incorporates  
27A0160

**27-62-11**

Page 1.1  
Sheet 3  
Aug 15/2007



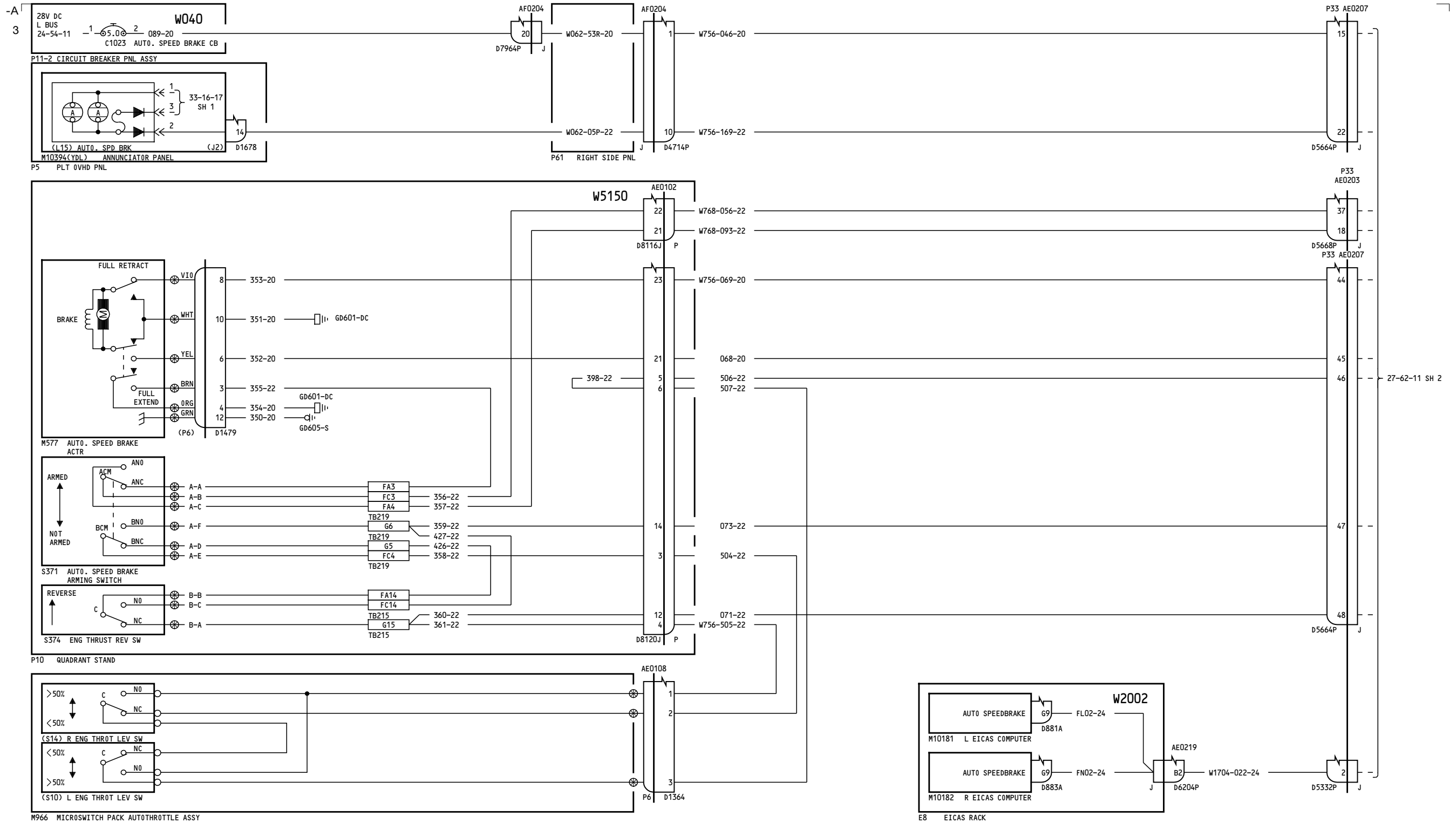

051, 151

**AUTOMATIC SPEED BRAKE SYSTEM**

**27-62-11**

Page 2.1  
Sheet 1  
Feb 06/2009

D280T132

**27-62-11**

Page 2.1  
Sheet 1  
Feb 06/2009

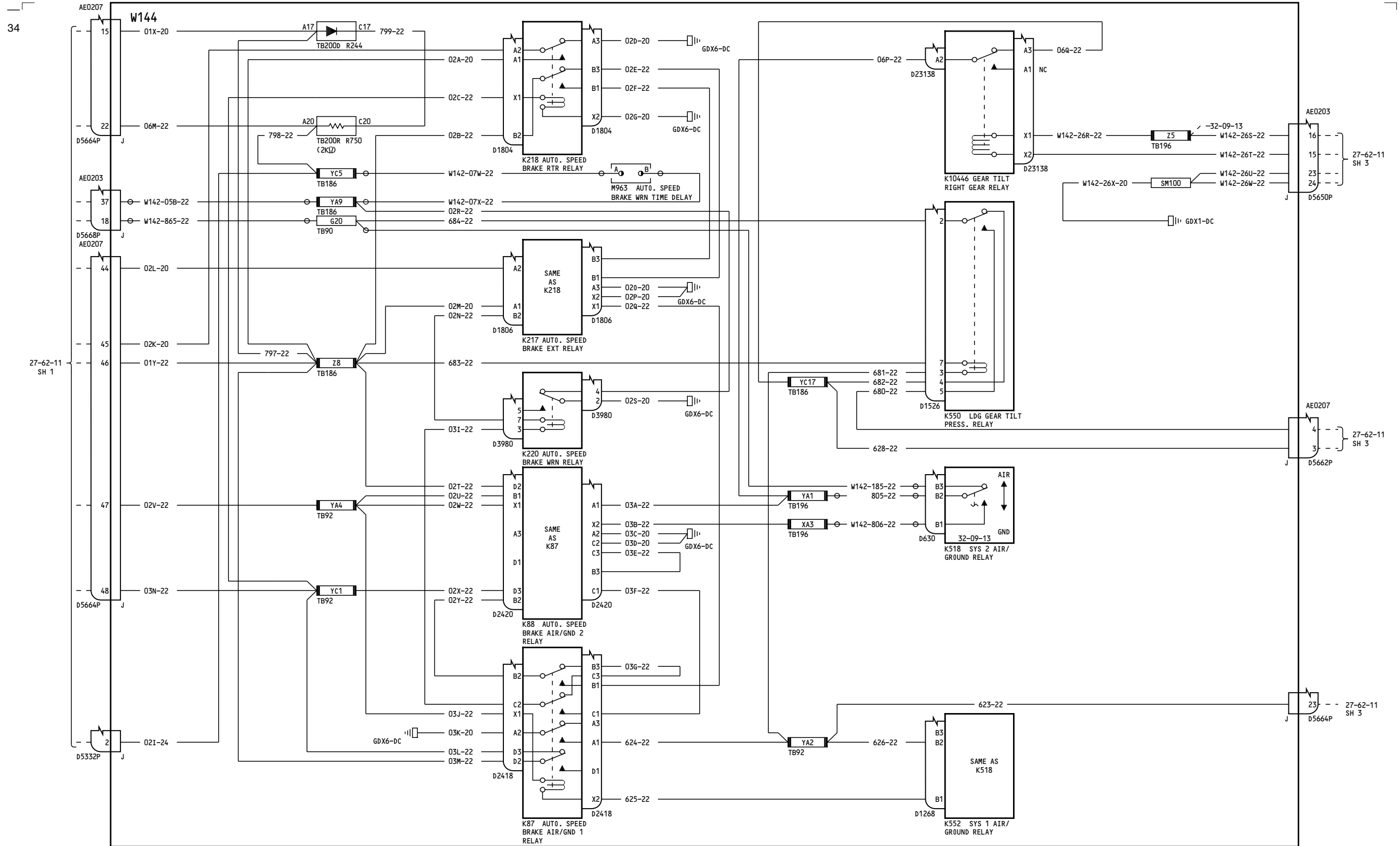

051, 151

**AUTOMATIC SPEED BRAKE SYSTEM**

**27-62-11**

Incorporates  
27A0160 R01

**27-62-11**

D280T132

Page 2.1  
Sheet 2  
Aug 15/2007

Page 2.1  
Sheet 2  
Aug 15/2007

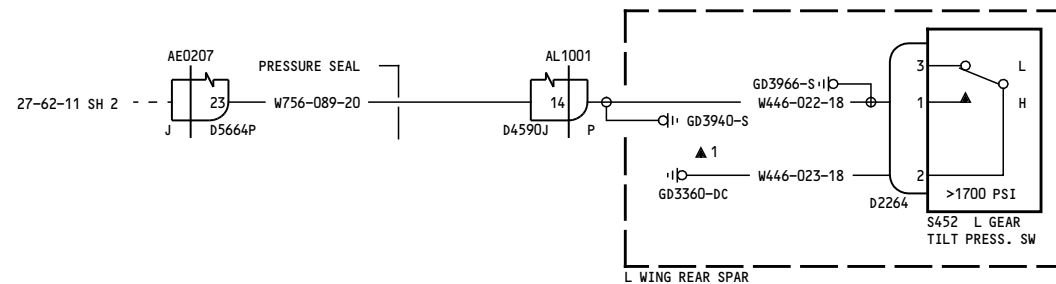
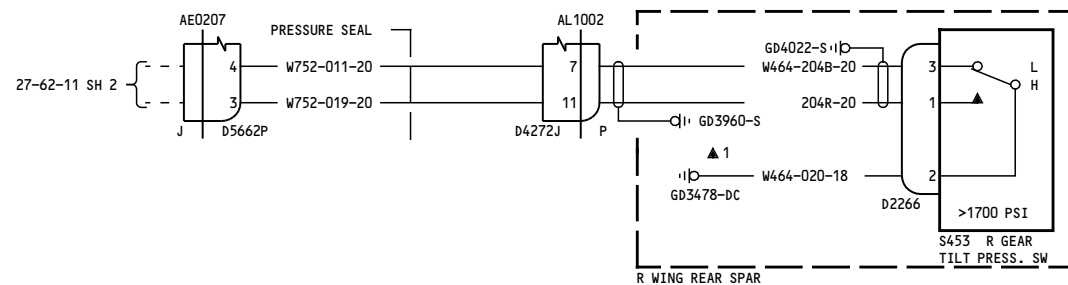
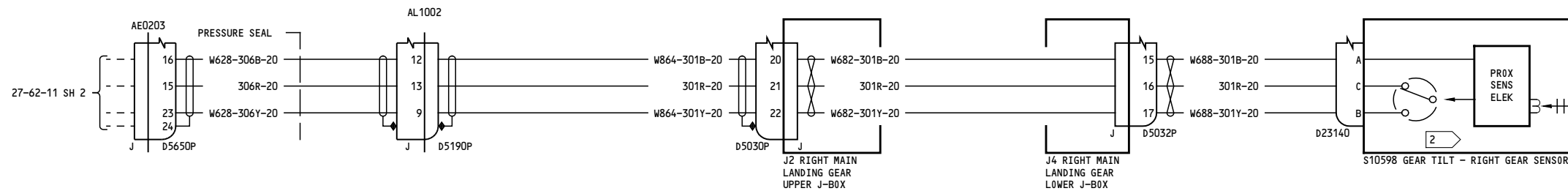

2 A "1" = GEAR TILT

051, 151

**AUTOMATIC SPEED BRAKE SYSTEM**

D280T132

**27-62-11**

Page 2.1  
Sheet 3  
Mar 09/2006

Incorporates  
27A0160 R01

**27-62-11**

Page 2.1  
Sheet 3  
Mar 09/2006

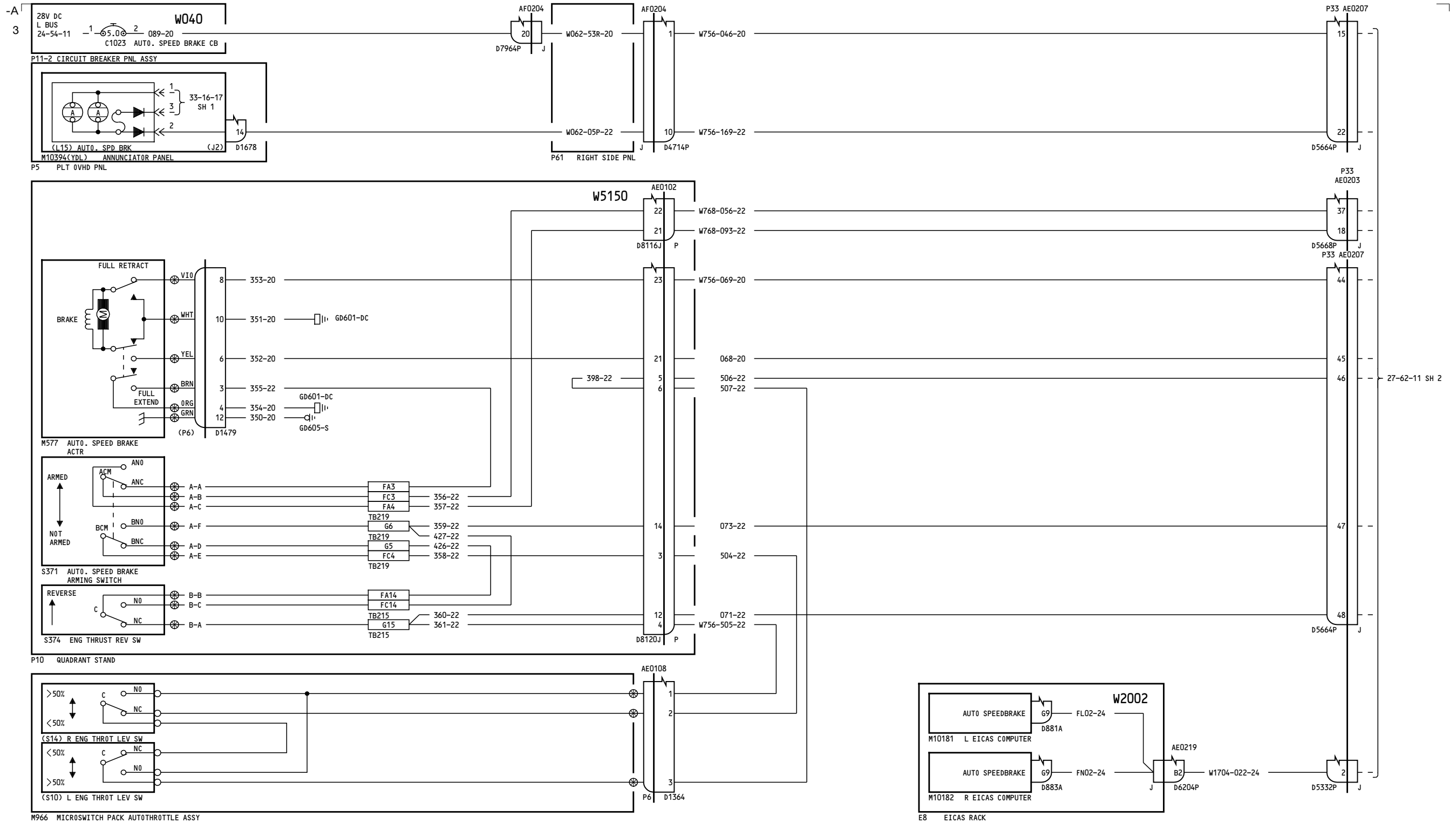

150, 152-280

**AUTOMATIC SPEED BRAKE SYSTEM**

**27-62-11**

Page 3.1  
Sheet 1  
Feb 06/2009

D280T132

**27-62-11**

Page 3.1  
Sheet 1  
Feb 06/2009

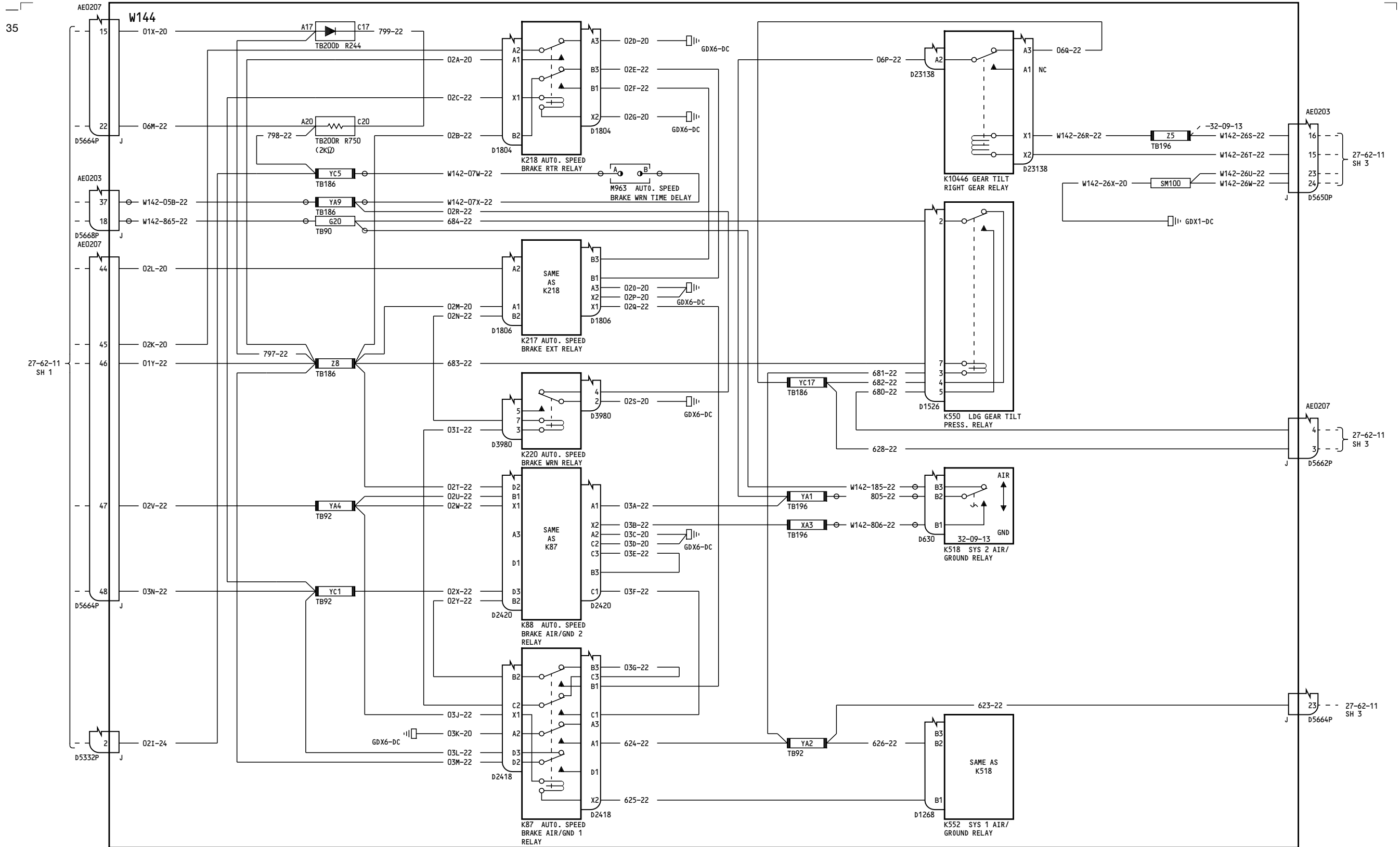

150, 152-280

**AUTOMATIC SPEED BRAKE SYSTEM**

**27-62-11**

Page 3.1  
Sheet 2  
Aug 15/2007

D280T132

Incorporates  
27A0160  
27A0160 R01

**27-62-11**

Page 3.1  
Sheet 2  
Aug 15/2007

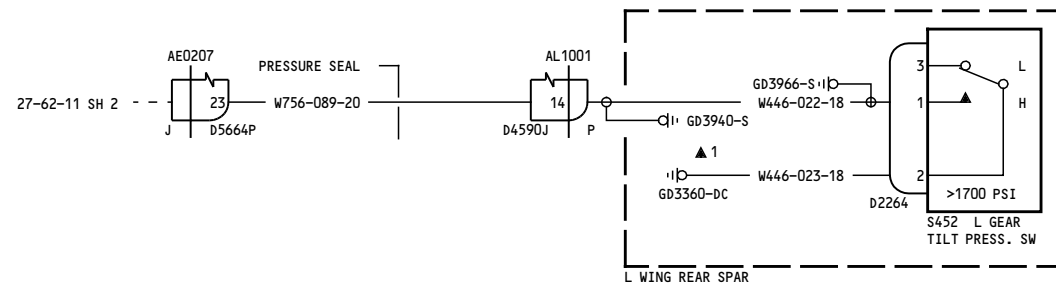
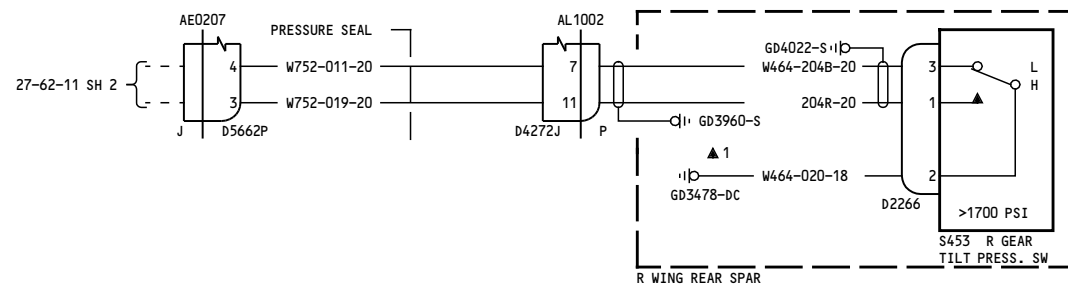
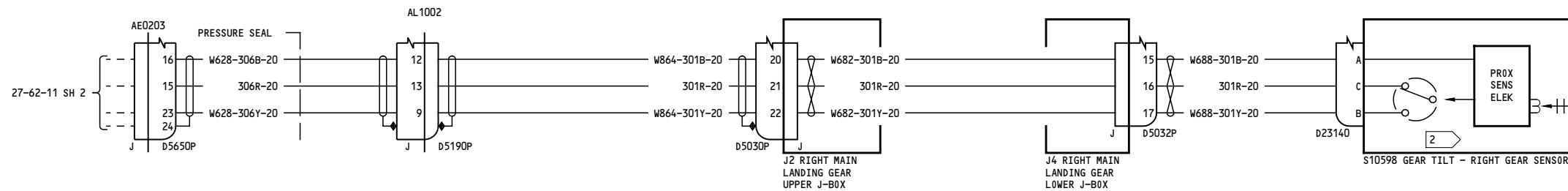

2 A "1" = GEAR TILT

150, 152-280

**AUTOMATIC SPEED BRAKE SYSTEM**

D280T132

**27-62-11**

Page 3.1  
Sheet 3  
Aug 15/2007

Incorporates  
27A0160

**27-62-11**

Page 3.1  
Sheet 3  
Aug 15/2007

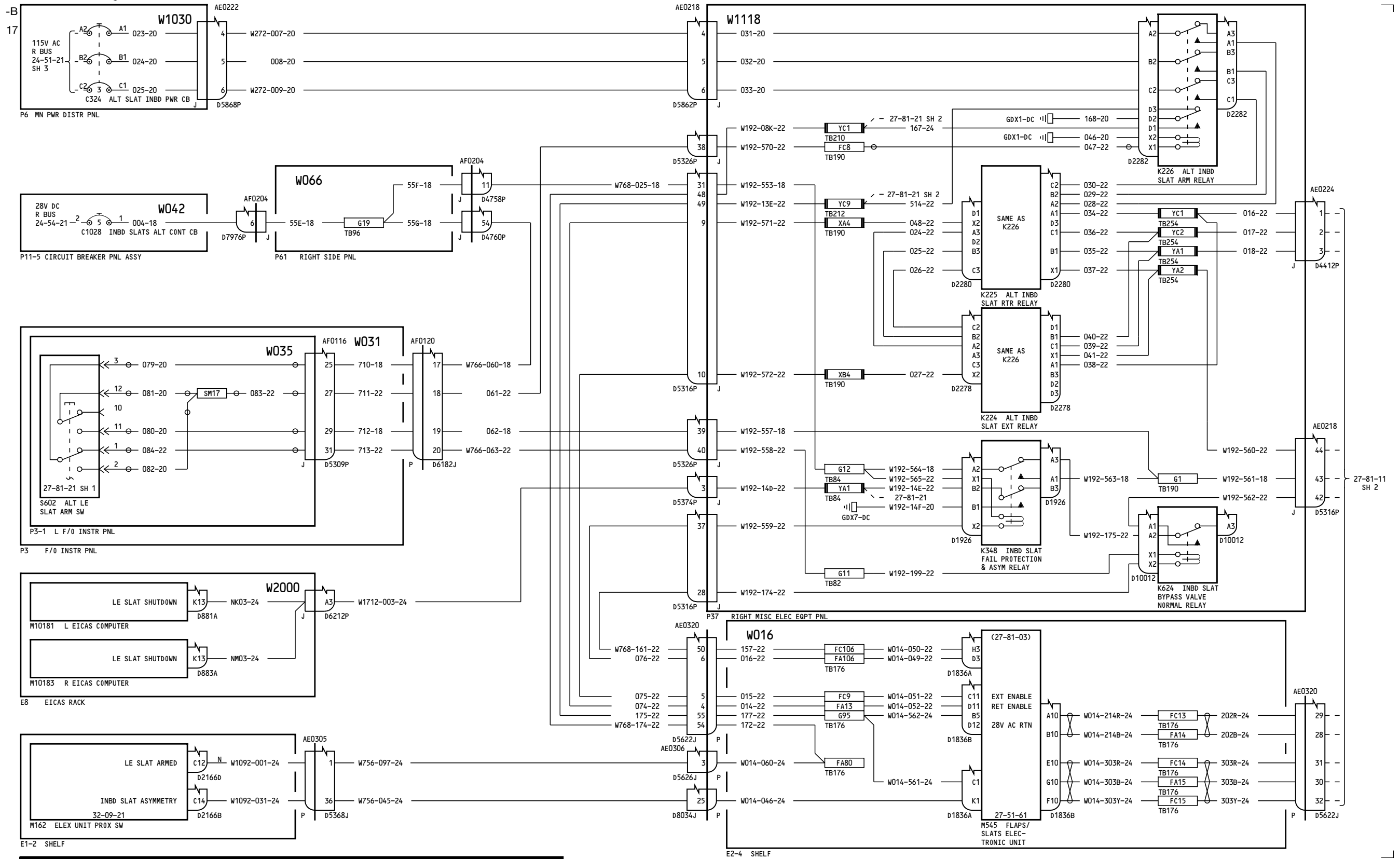

050-280

**ALTERNATE LEADING EDGE INBOARD SLAT DRIVE**

D280T132

**27-81-11**

Page 1.1  
Sheet 1  
Jan 21/2005

Incorporates  
27-0133

**27-81-11**

Page 1.1  
Sheet 1  
Jan 21/2005

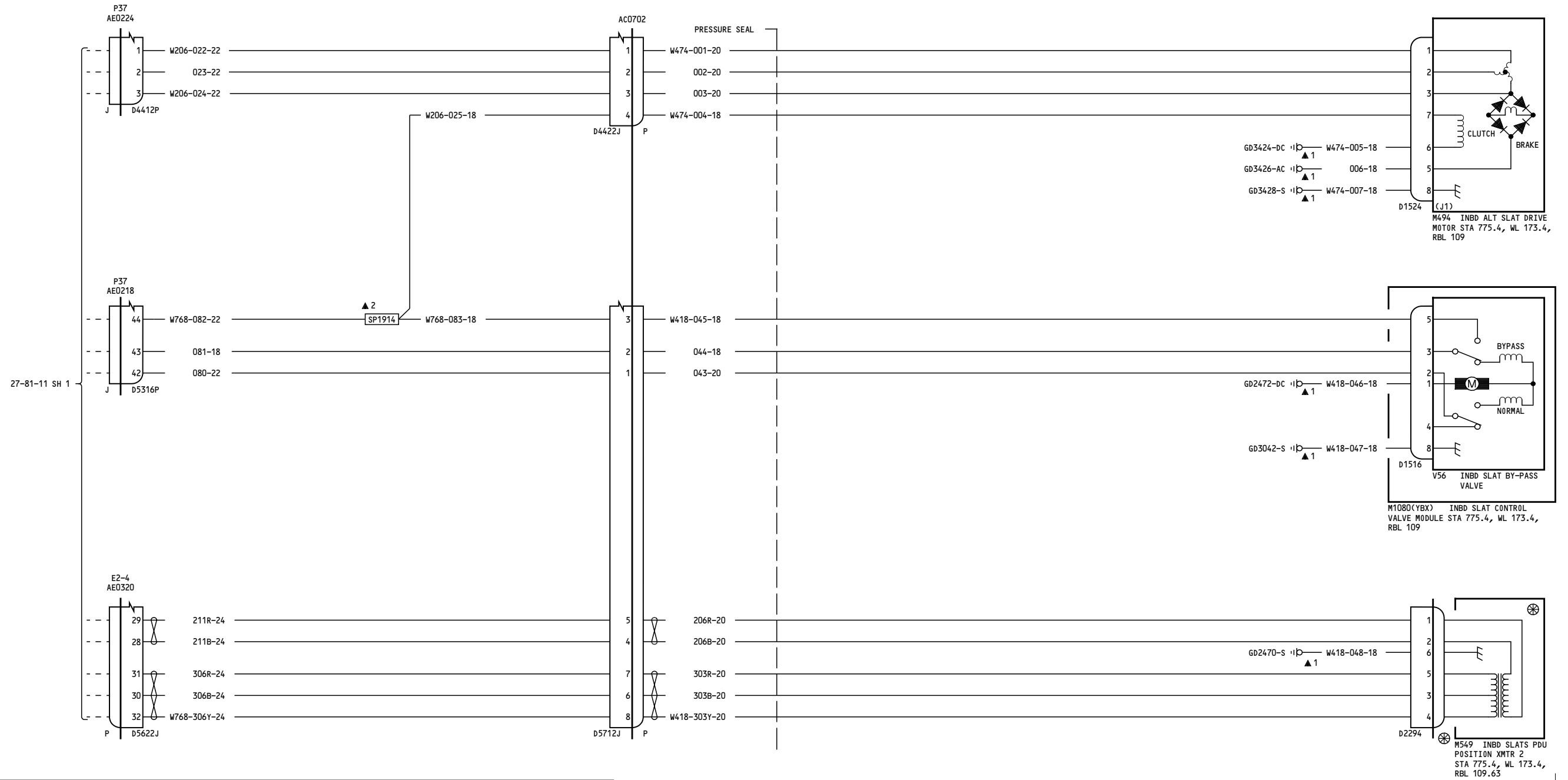

050-280

**ALTERNATE LEADING EDGE  
INBOARD SLAT DRIVE**

D280T132

**27-81-11**

Page 1.1  
Sheet 2  
Jan 21/2005

**27-81-11**

Page 1.1  
Sheet 2  
Jan 21/2005



28

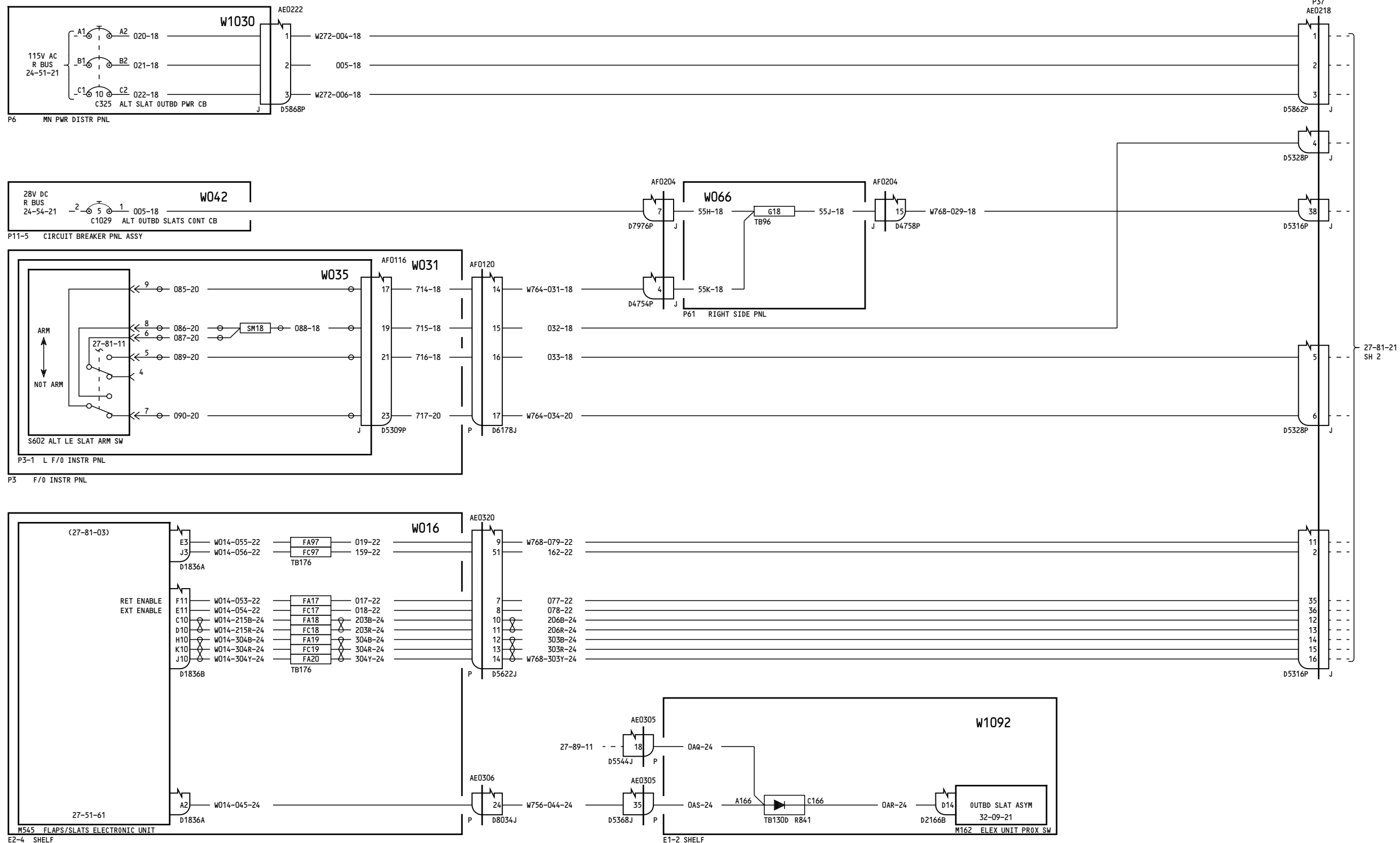

050-051

**ALTERNATE LEADING EDGE  
OUTBOARD SLAT DRIVE**

D280T132

**27-81-21**

Page 1.1  
Sheet 1  
Jan 21/2005

**27-81-21**

Page 1.1  
Sheet 1  
Jan 21/2005

-B  
31

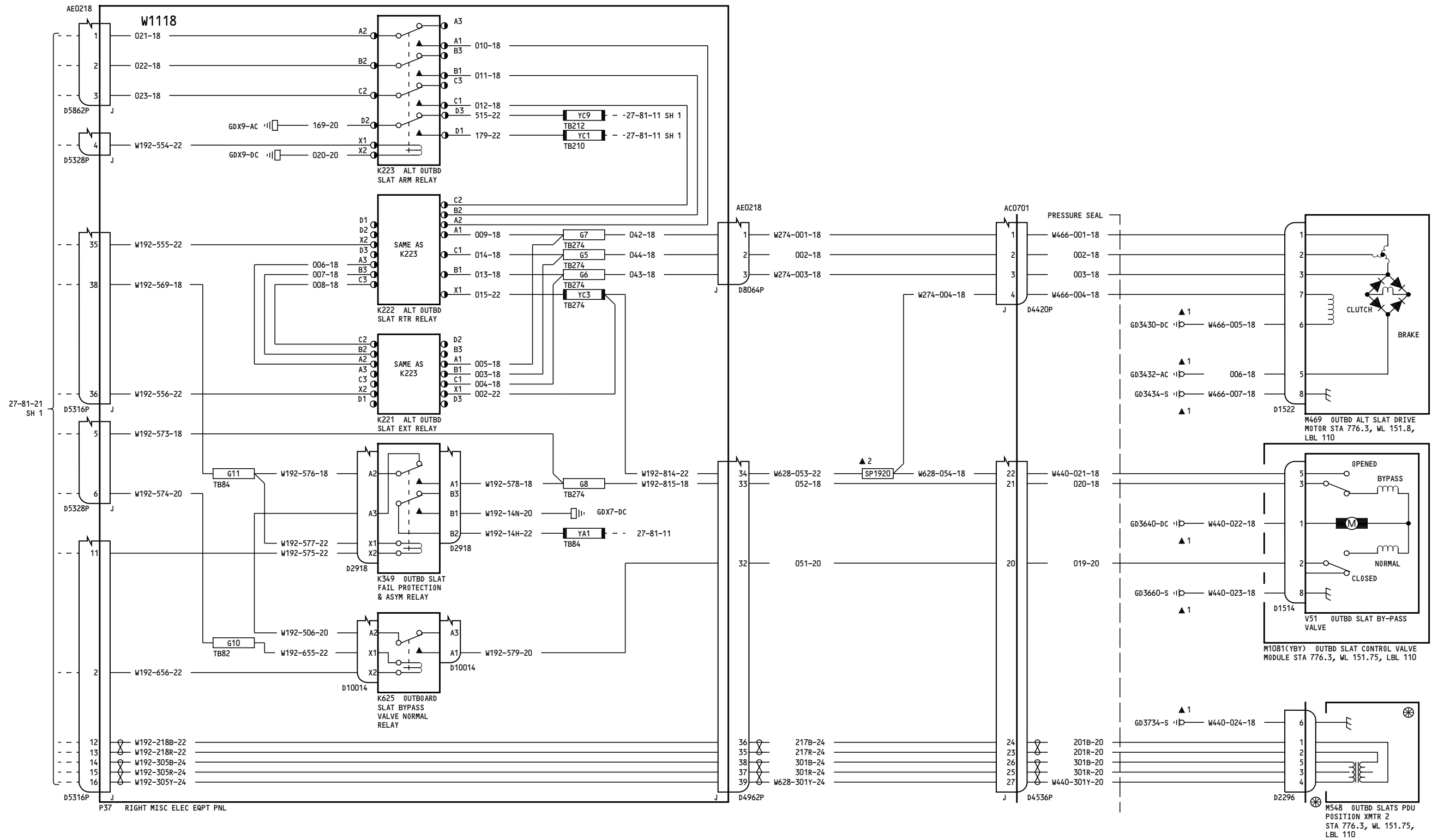

050-051

**ALTERNATE LEADING EDGE  
OUTBOARD SLAT DRIVE**

**27-81-21**

Page 1.1  
Sheet 2  
Jan 21/2005

D280T132

Incorporates  
27-0133

**27-81-21**

Page 1.1  
Sheet 2  
Jan 21/2005

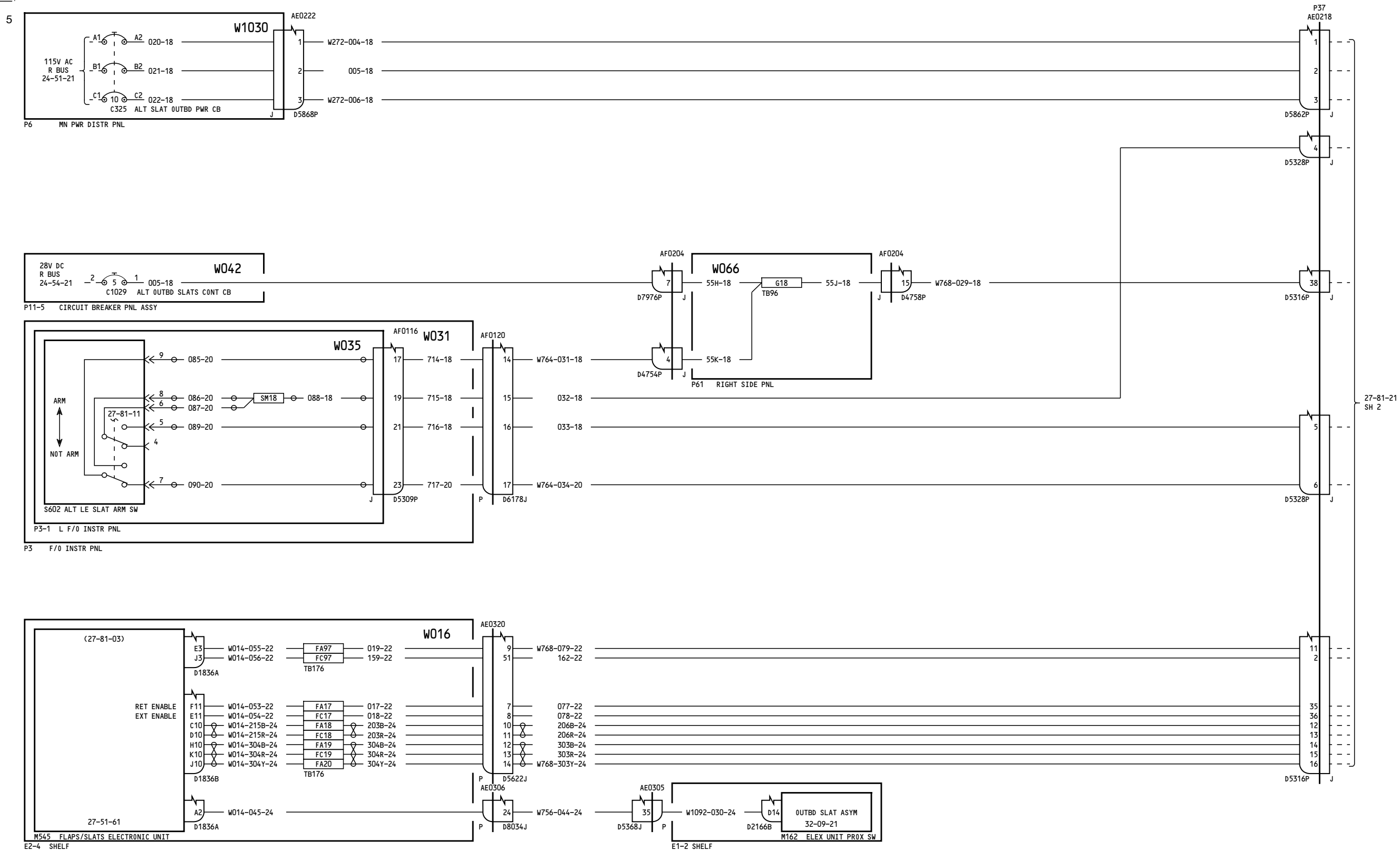

151

**ALTERNATE LEADING EDGE  
OUTBOARD SLAT DRIVE**

D280T132

**27-81-21**

Page 2  
Sheet 1  
Jan 21/2005

**27-81-21**

Page 2  
Sheet 1  
Jan 21/2005

5

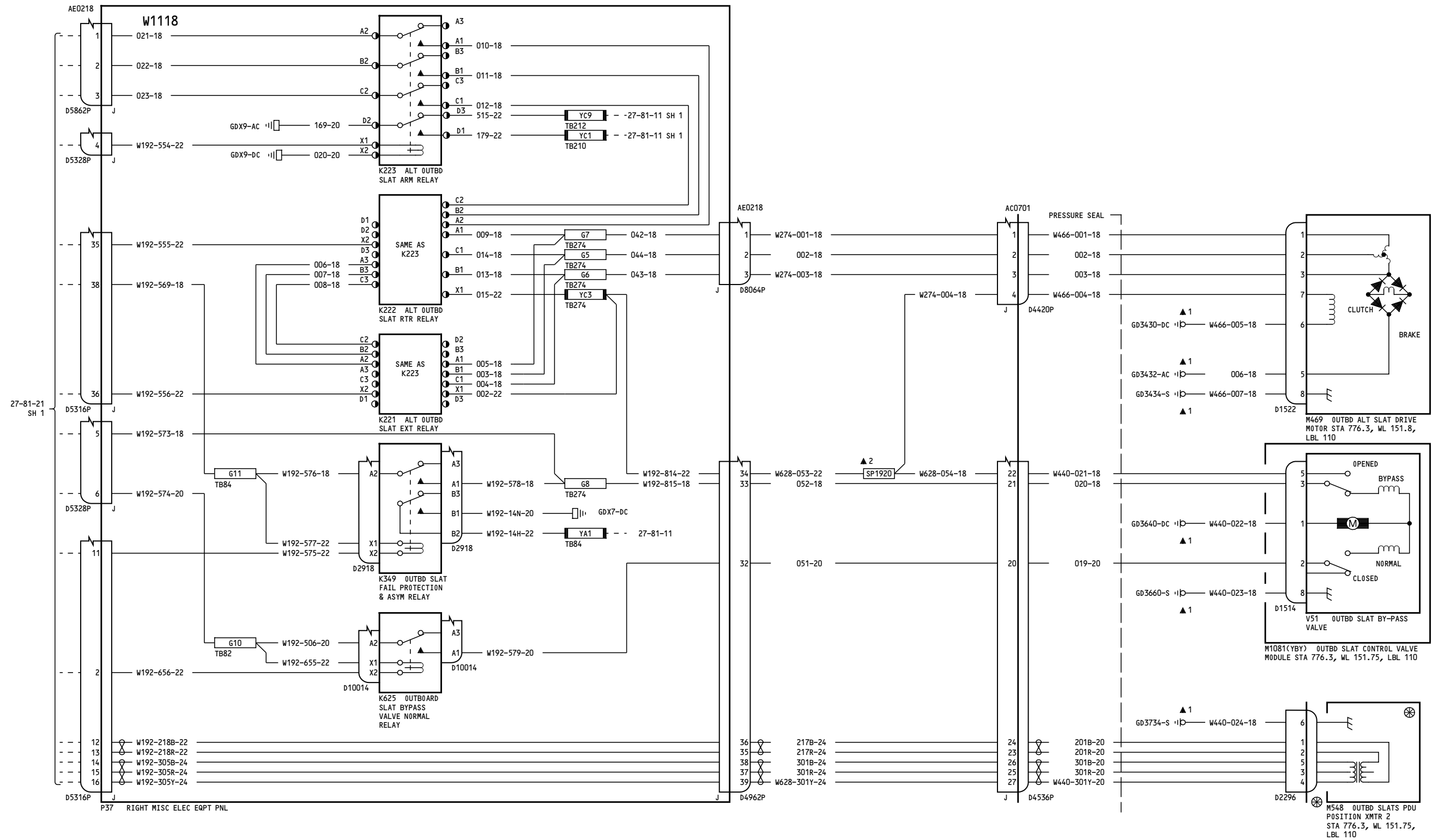

ALTERNATE LEADING EDGE OUTBOARD SLAT DRIVE

27-81-21

D280T132

27-81-21

28

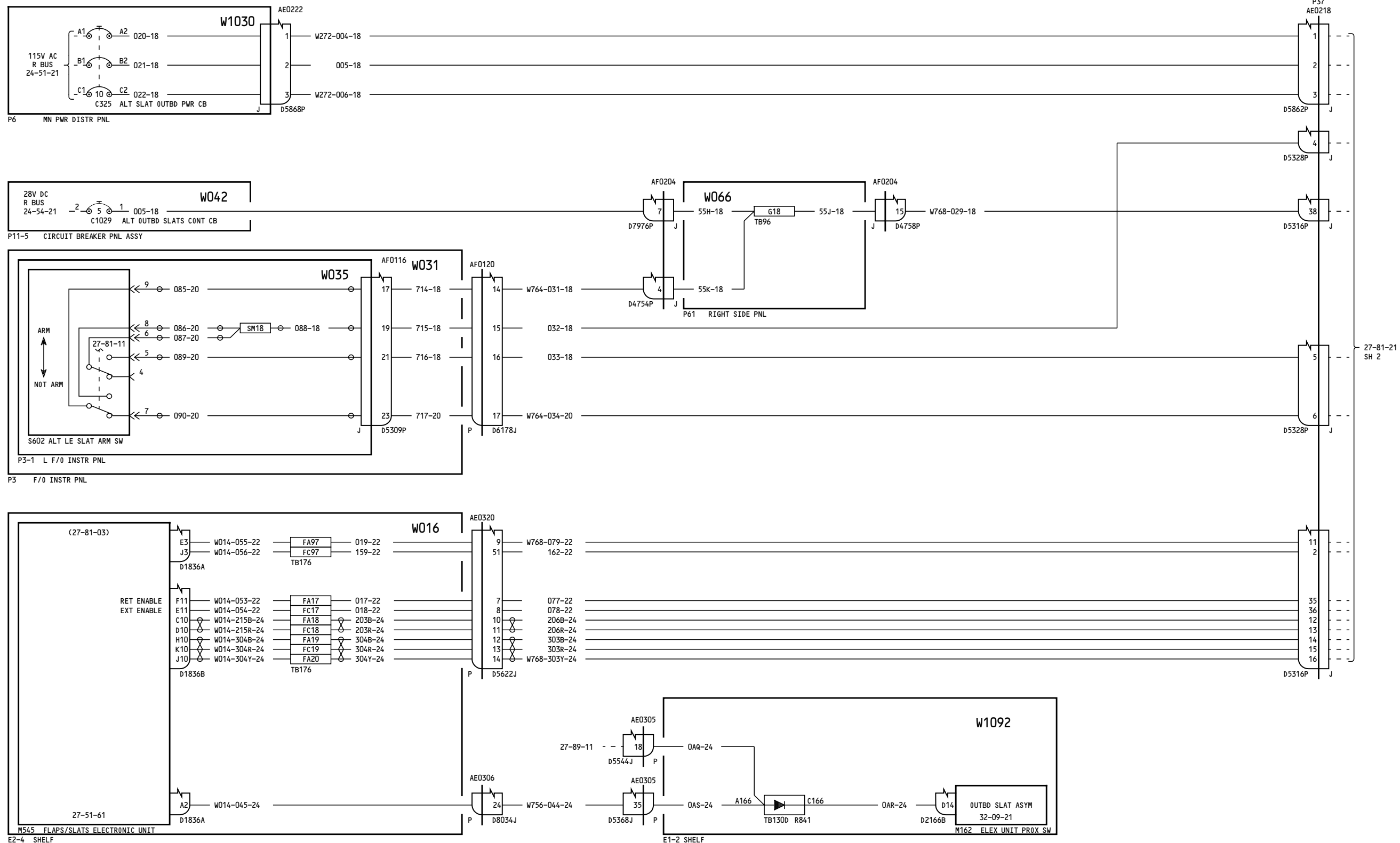

150-278

**ALTERNATE LEADING EDGE  
OUTBOARD SLAT DRIVE**

D280T132

**27-81-21**

Page 2.1  
Sheet 1  
Jan 21/2005

Incorporates  
27A0140

**27-81-21**

Page 2.1  
Sheet 1  
Jan 21/2005

-B  
31

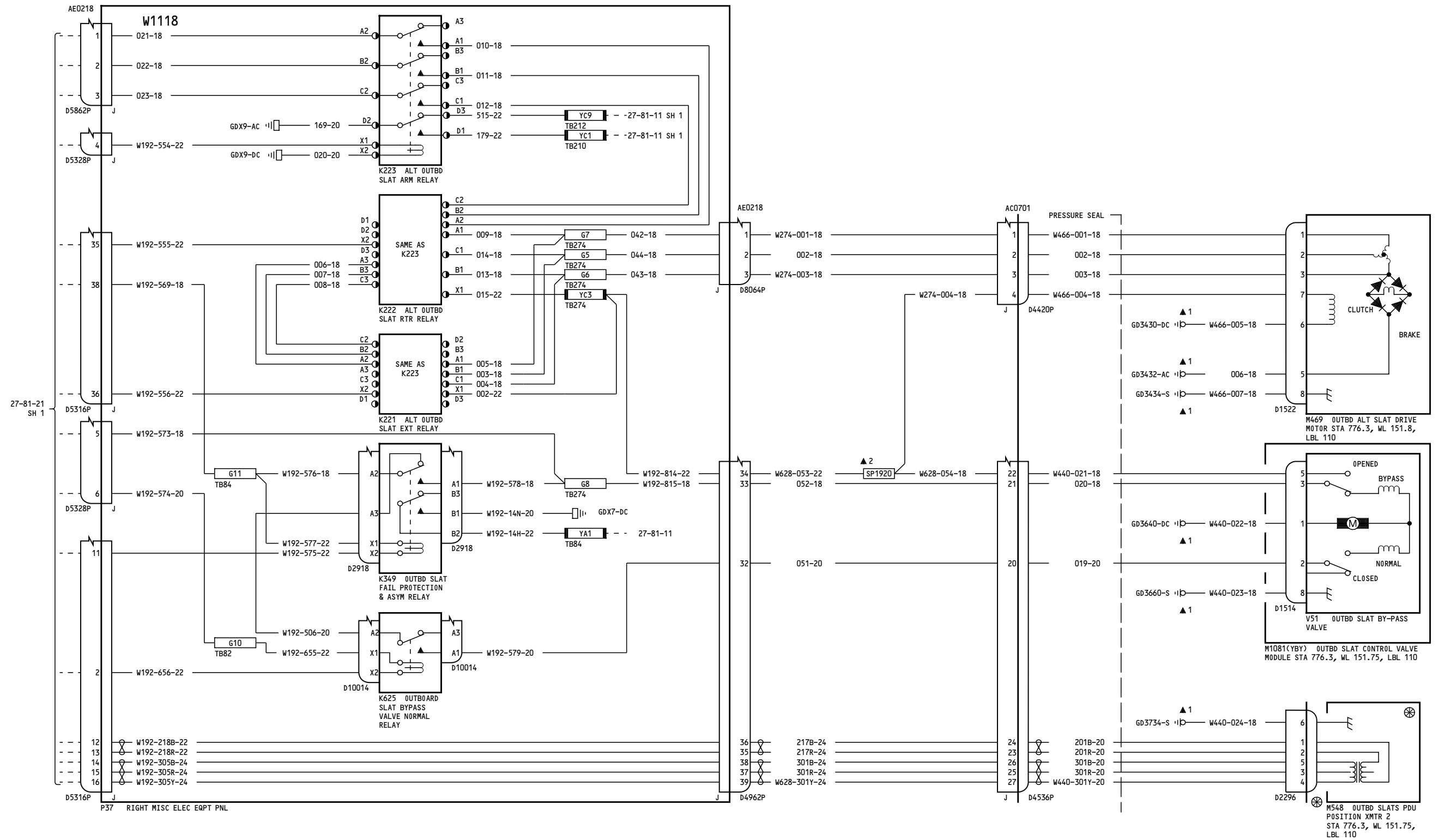

150-278

ALTERNATE LEADING EDGE  
OUTBOARD SLAT DRIVE

27-81-21

Page 2.1  
Sheet 2  
Jan 21/2005

D280T132

Incorporates  
27-0133

27-81-21

Page 2.1  
Sheet 2  
Jan 21/2005

28

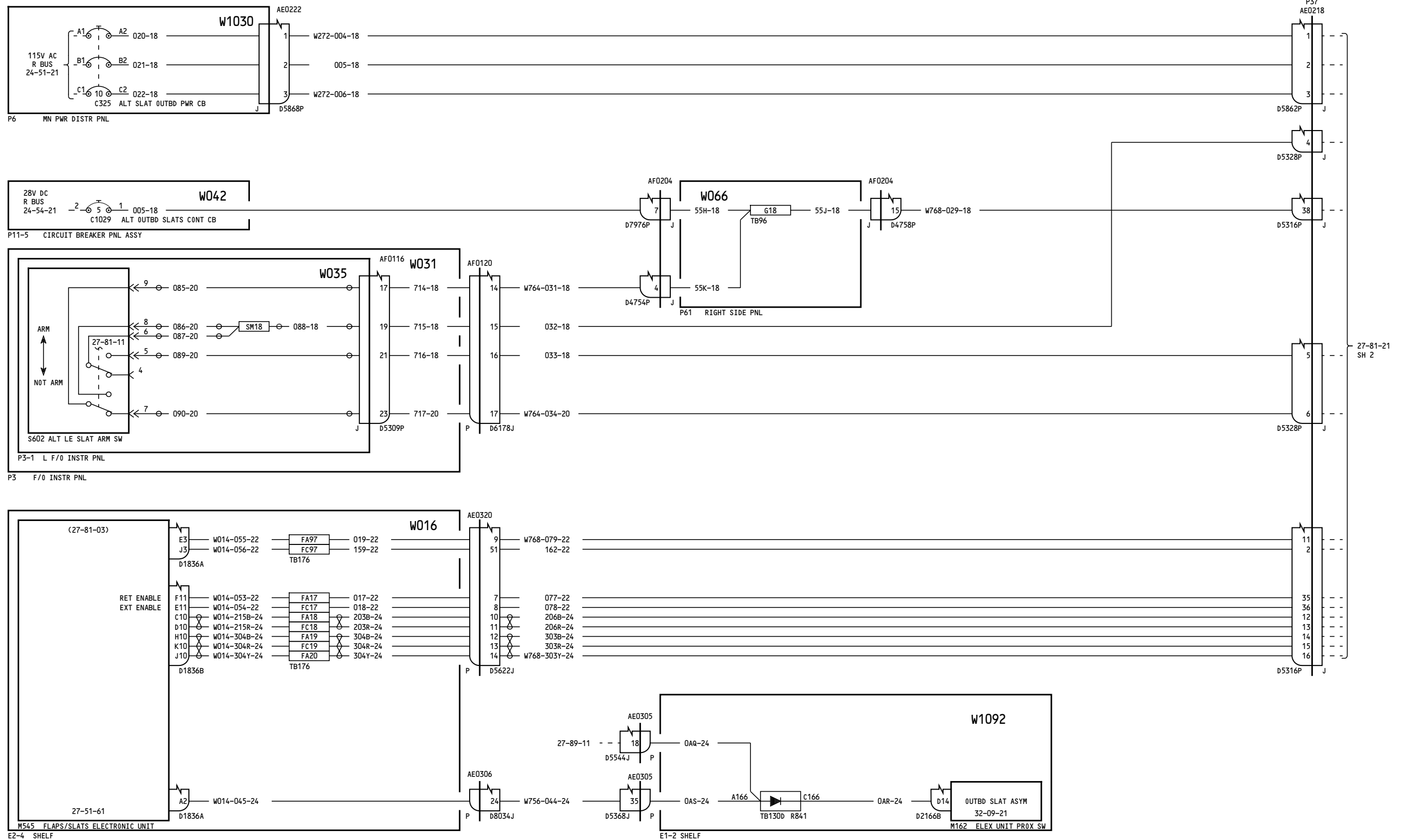

280

**ALTERNATE LEADING EDGE  
OUTBOARD SLAT DRIVE**

D280T132

**27-81-21**

Page 3.1  
Sheet 1  
Jan 21/2005

Incorporates  
27A0140 R01

**27-81-21**

Page 3.1  
Sheet 1  
Jan 21/2005

-B  
31

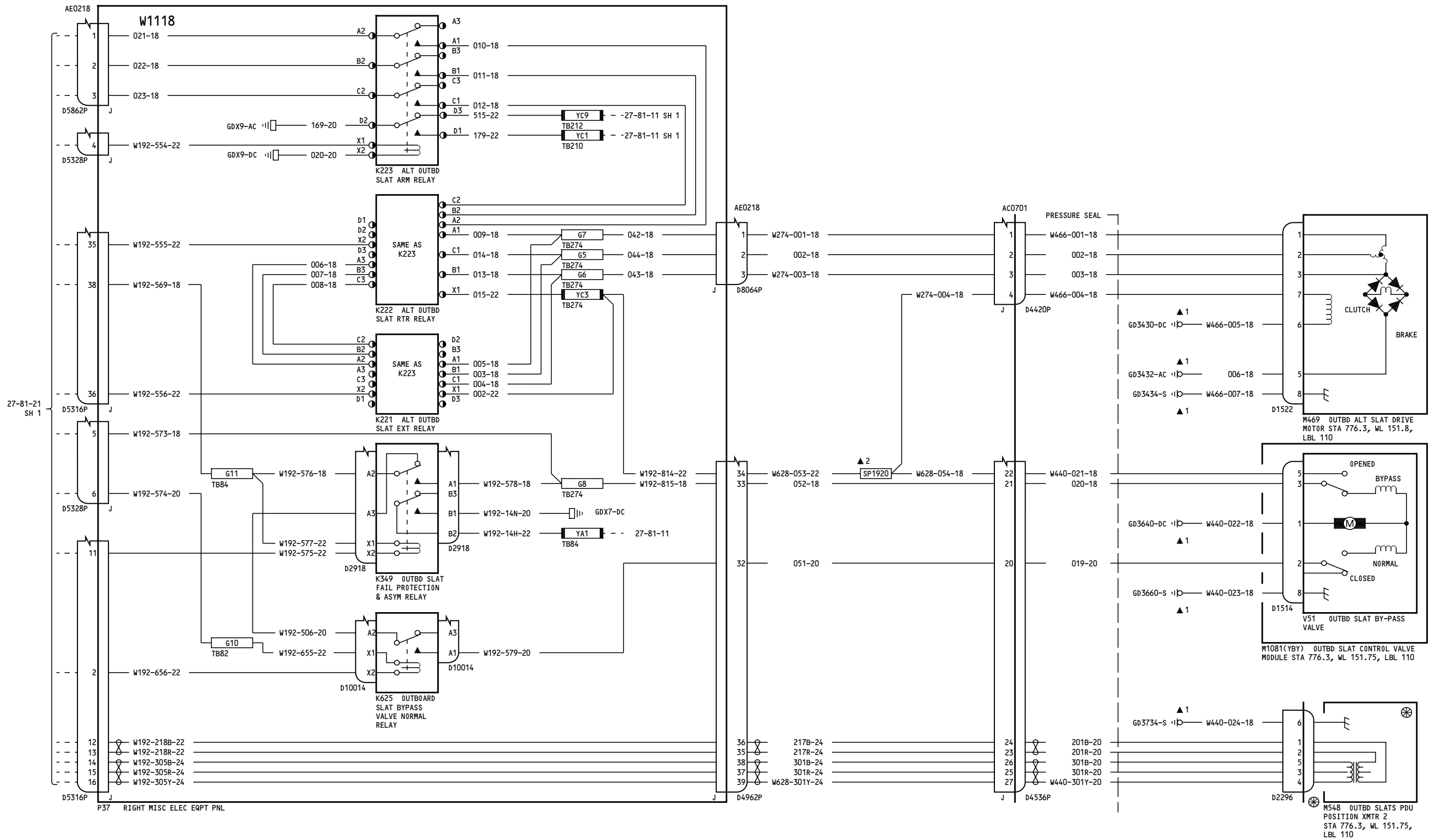

280

**ALTERNATE LEADING EDGE  
OUTBOARD SLAT DRIVE**

**27-81-21**

Page 3.1  
Sheet 2  
Jan 21/2005

D280T132

Incorporates  
27-0133

**27-81-21**

Page 3.1  
Sheet 2  
Jan 21/2005



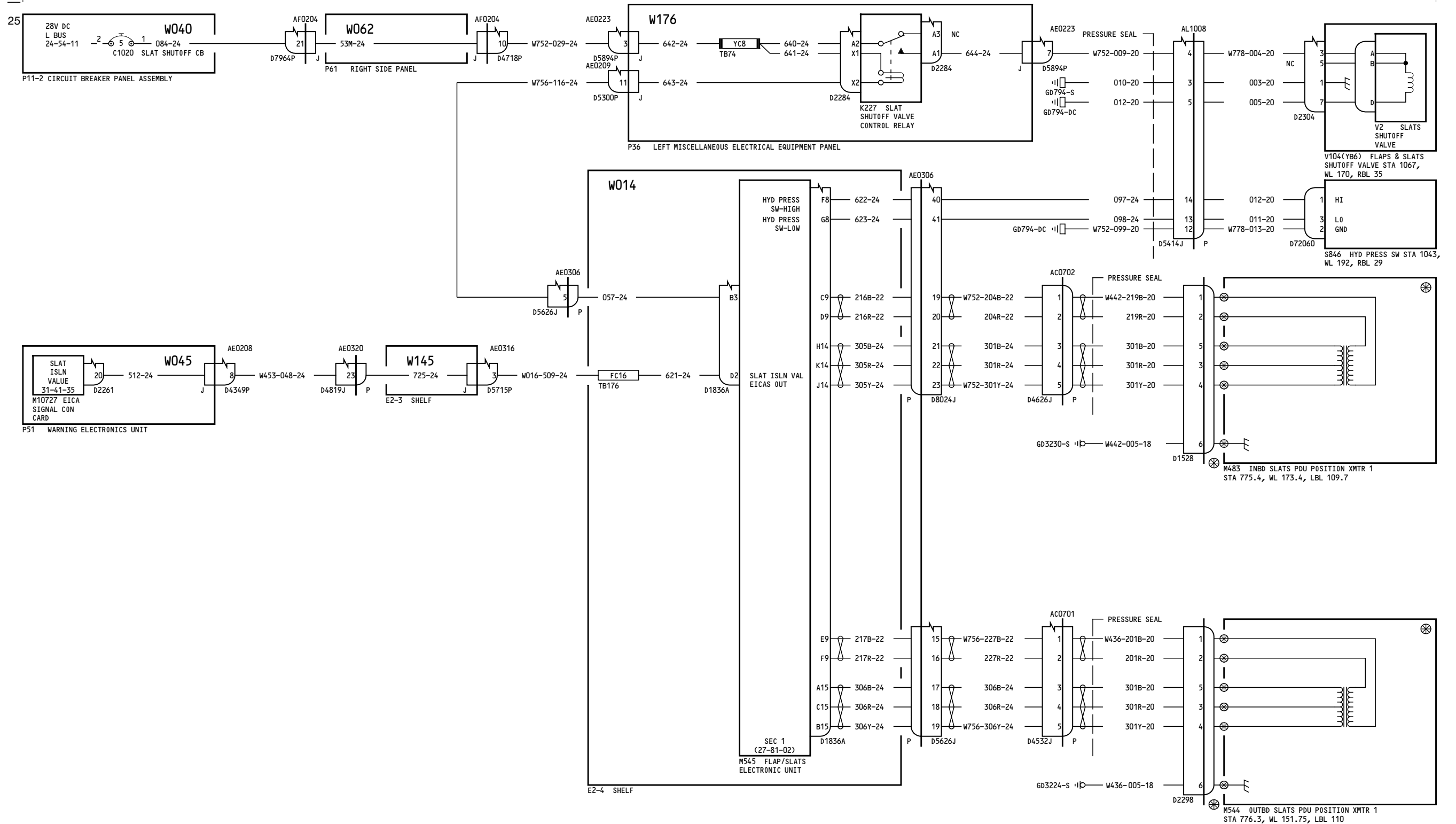

050-051

**LEADING EDGE SLATS SHUTOFF VALVE**

**27-81-31**

Page 1.1

Jan 21/2005

D280T132

Incorporates  
27-0108 R02

**27-81-31**

Page 1.1

Jan 21/2005

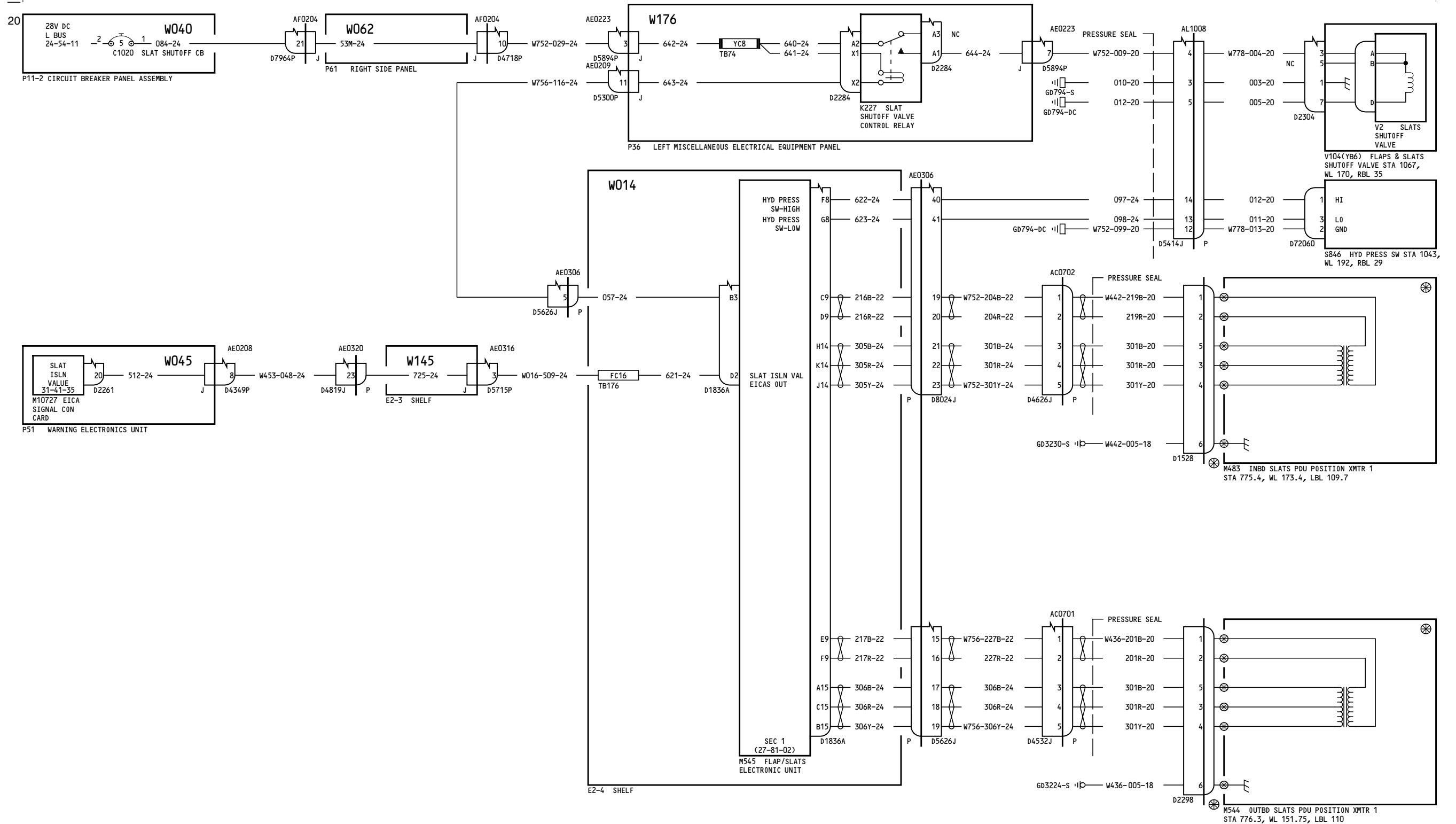

150-156, 162-166, 275-276

**LEADING EDGE SLATS SHUTOFF VALVE**

**27-81-31**

Incorporates  
27-0108 R02

Page 2.1

D280T132

Jan 21/2005

**27-81-31**

Page 2.1

Jan 21/2005

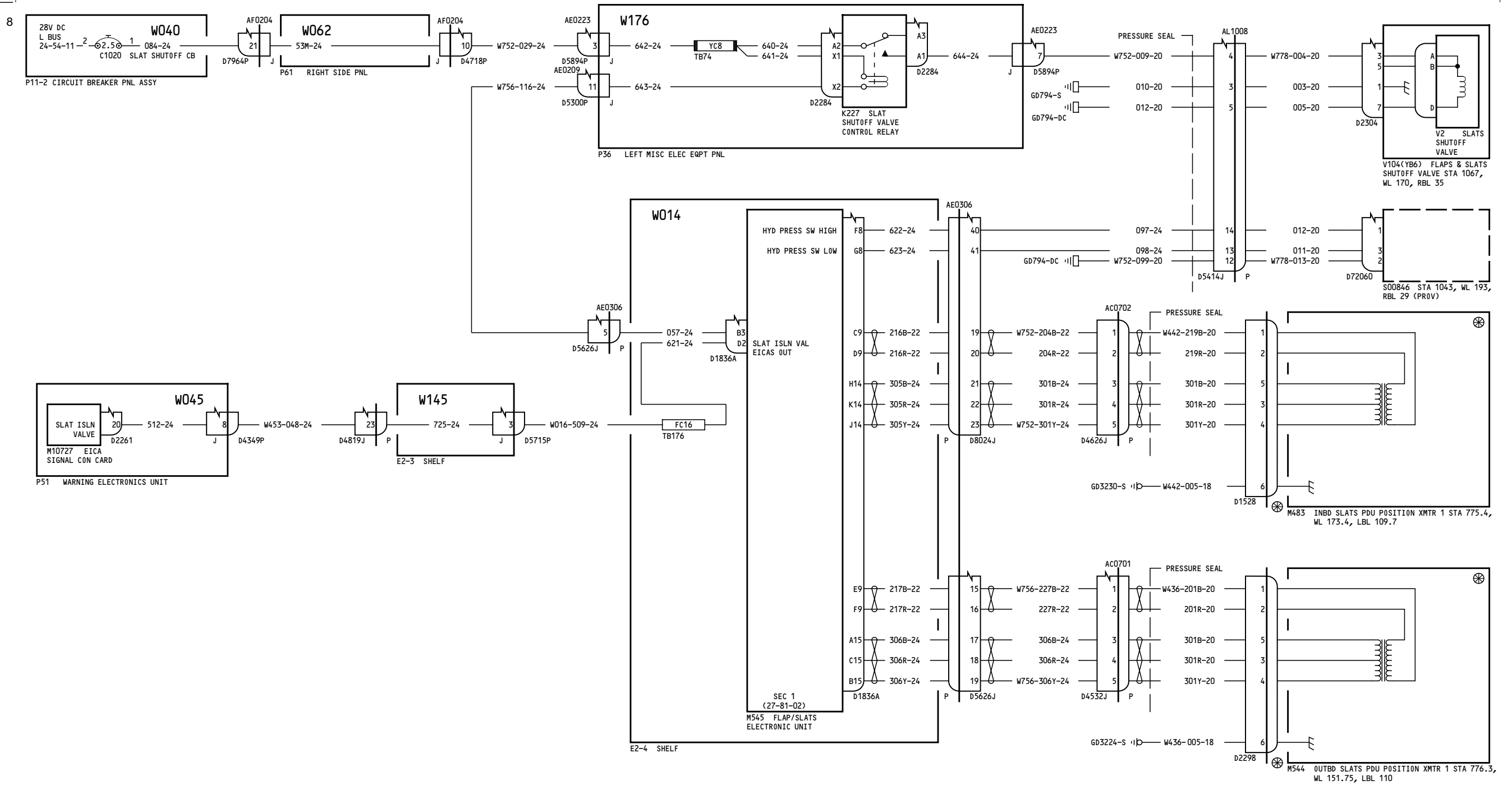

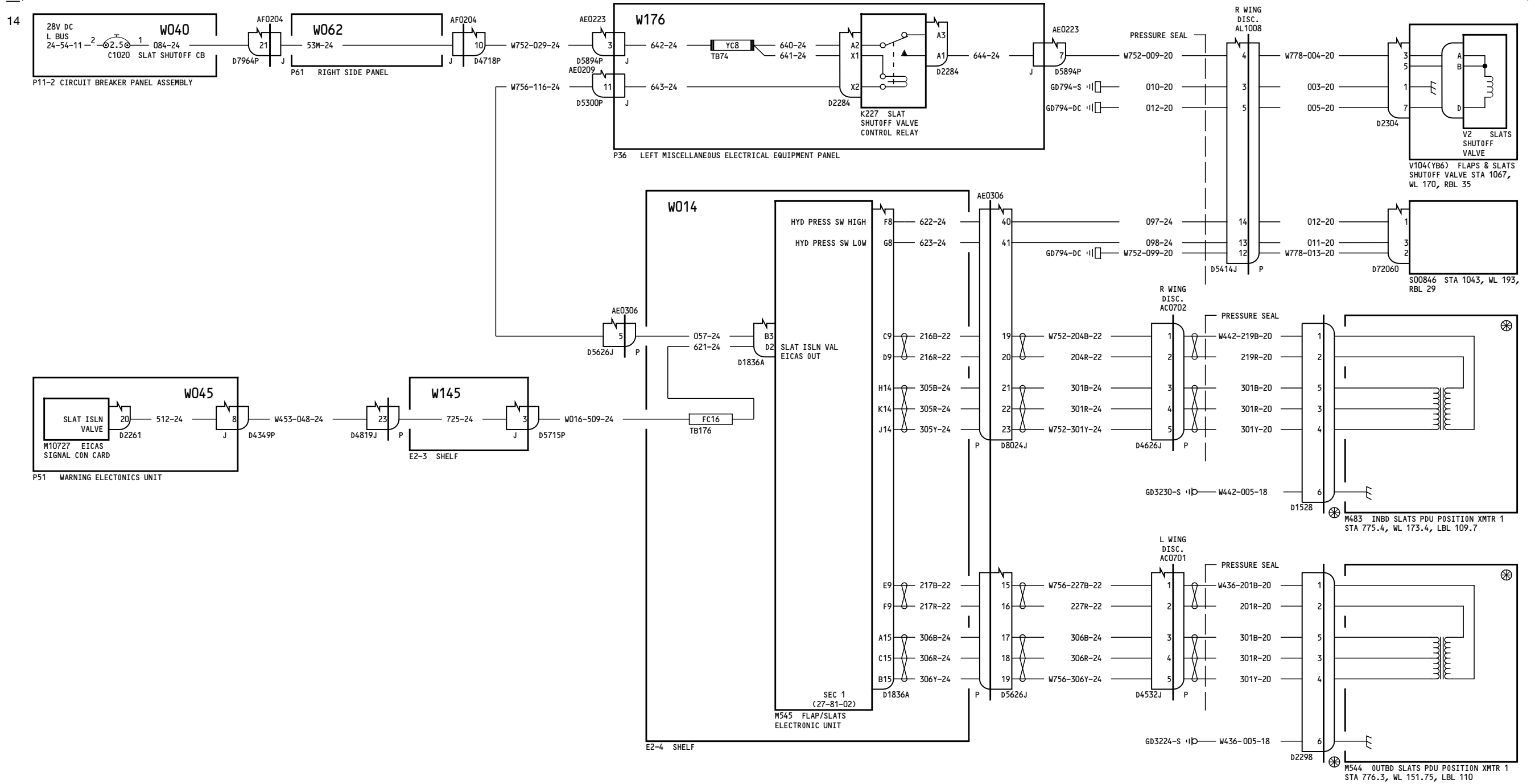

167-199, 278-299

**LEADING EDGE SLATS SHUTOFF VALVE**

**27-81-31**

Page 4

D280T132

Jan 21/2005

**27-81-31**

Page 4

Jan 21/2005

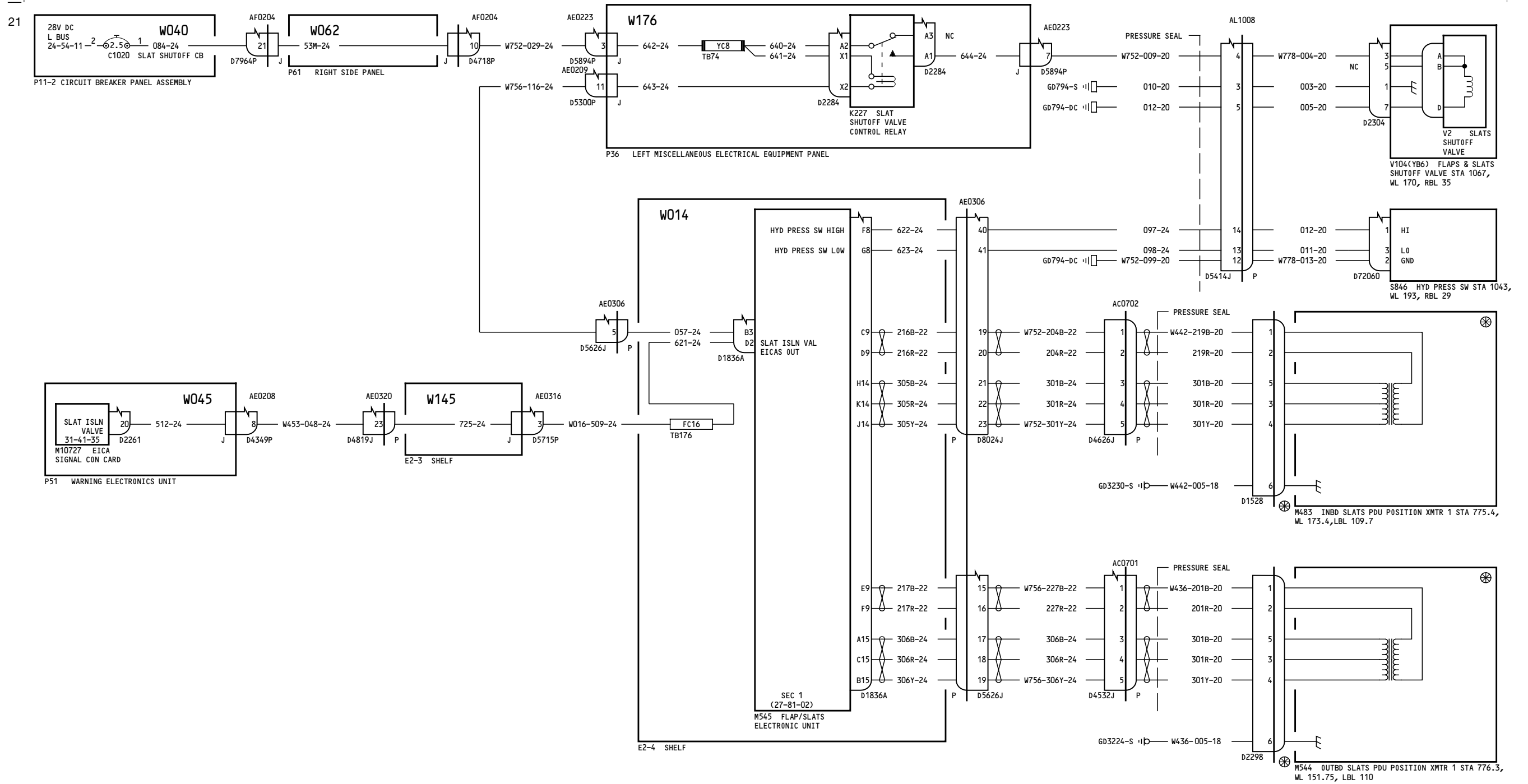

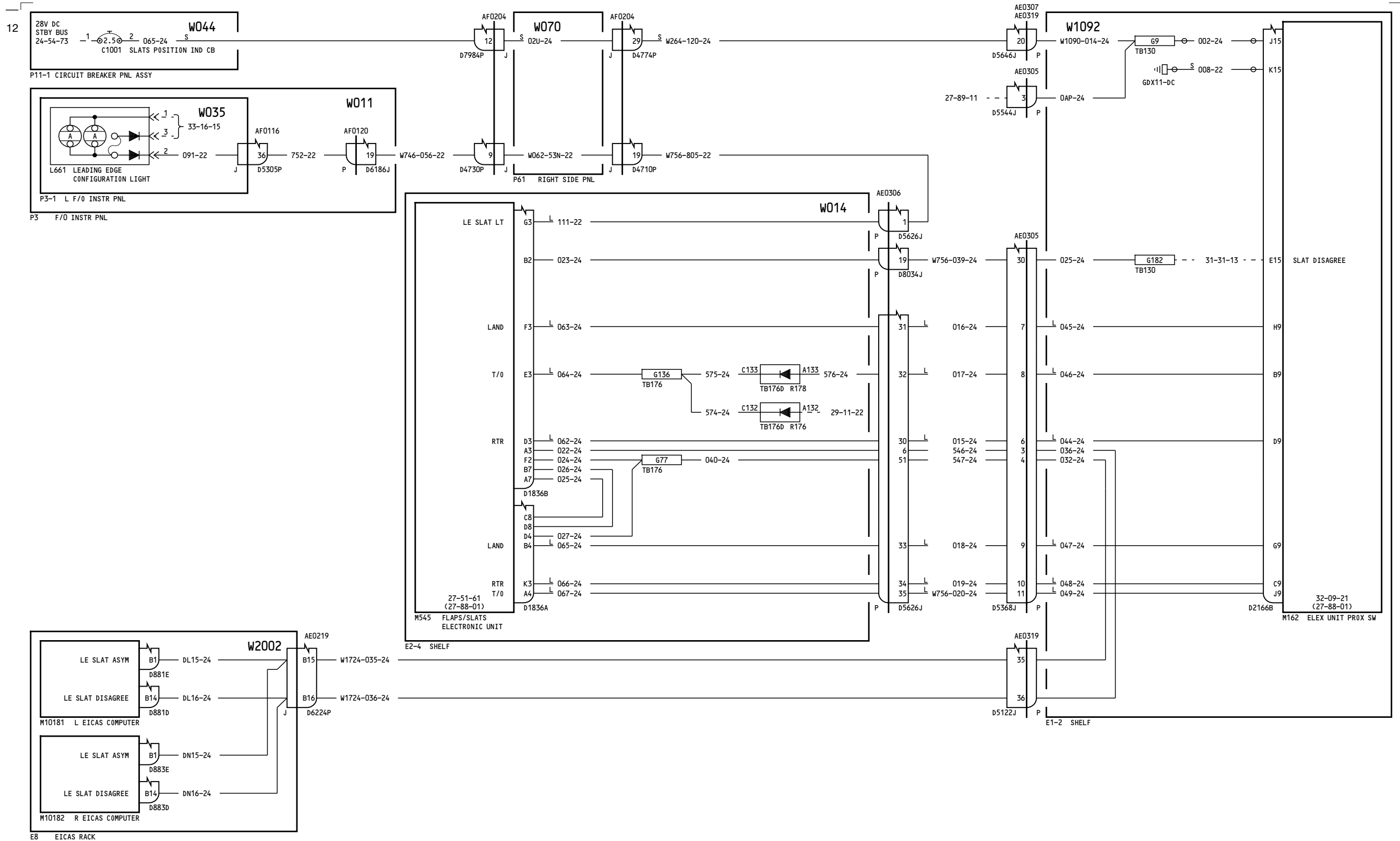

050-099

**LEADING EDGE SLAT  
POSITION INDICATION-  
LEFT WING**

**27-88-11**

**27-88-11**

Page 1

Page 1

D280T132

Jan 21/2005

Jan 21/2005

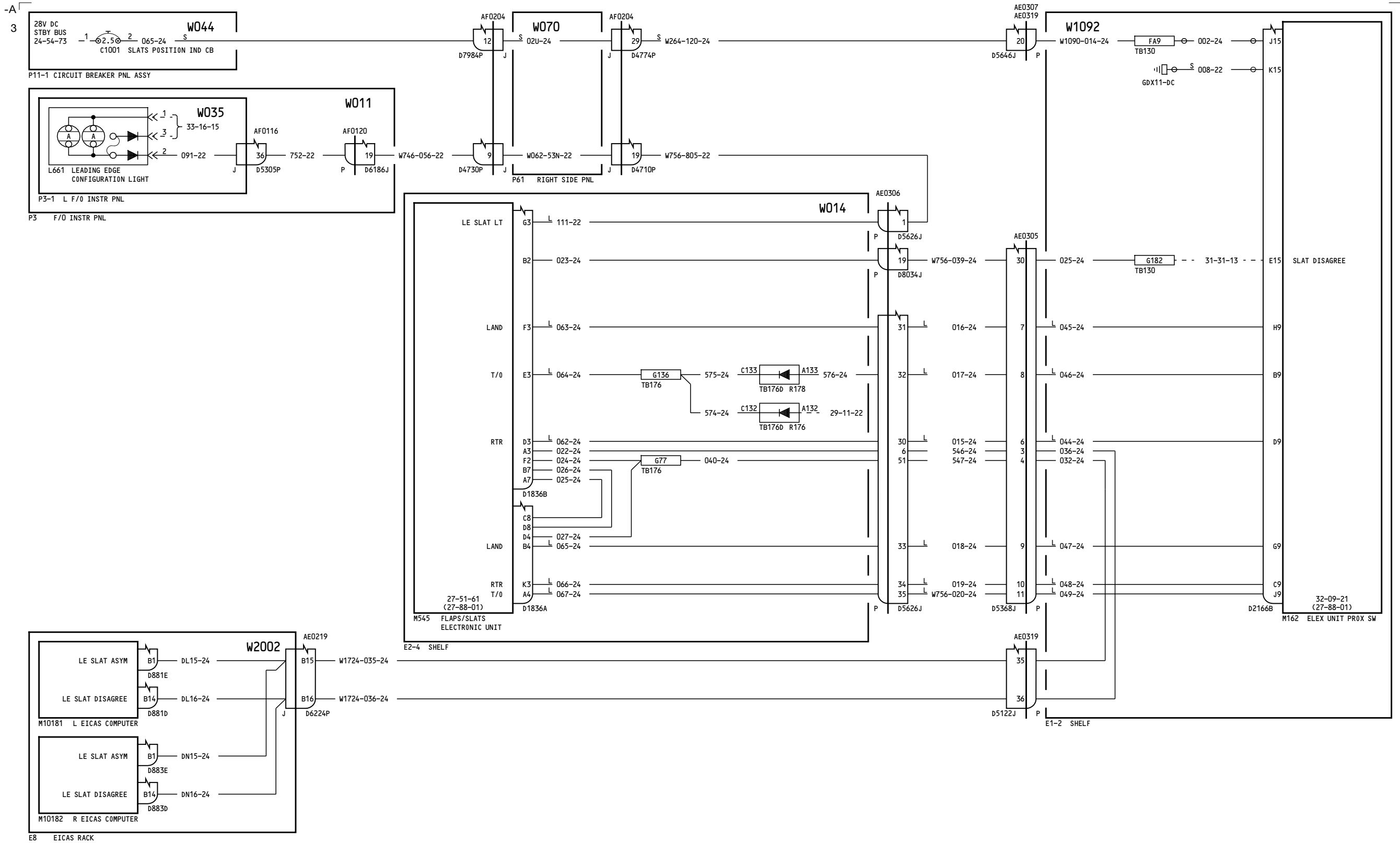

151

**LEADING EDGE SLAT  
POSITION INDICATION-  
LEFT WING**

D280T132

**27-88-11**

Page 2

Jan 21/2005

**27-88-11**

Page 2

Jan 21/2005

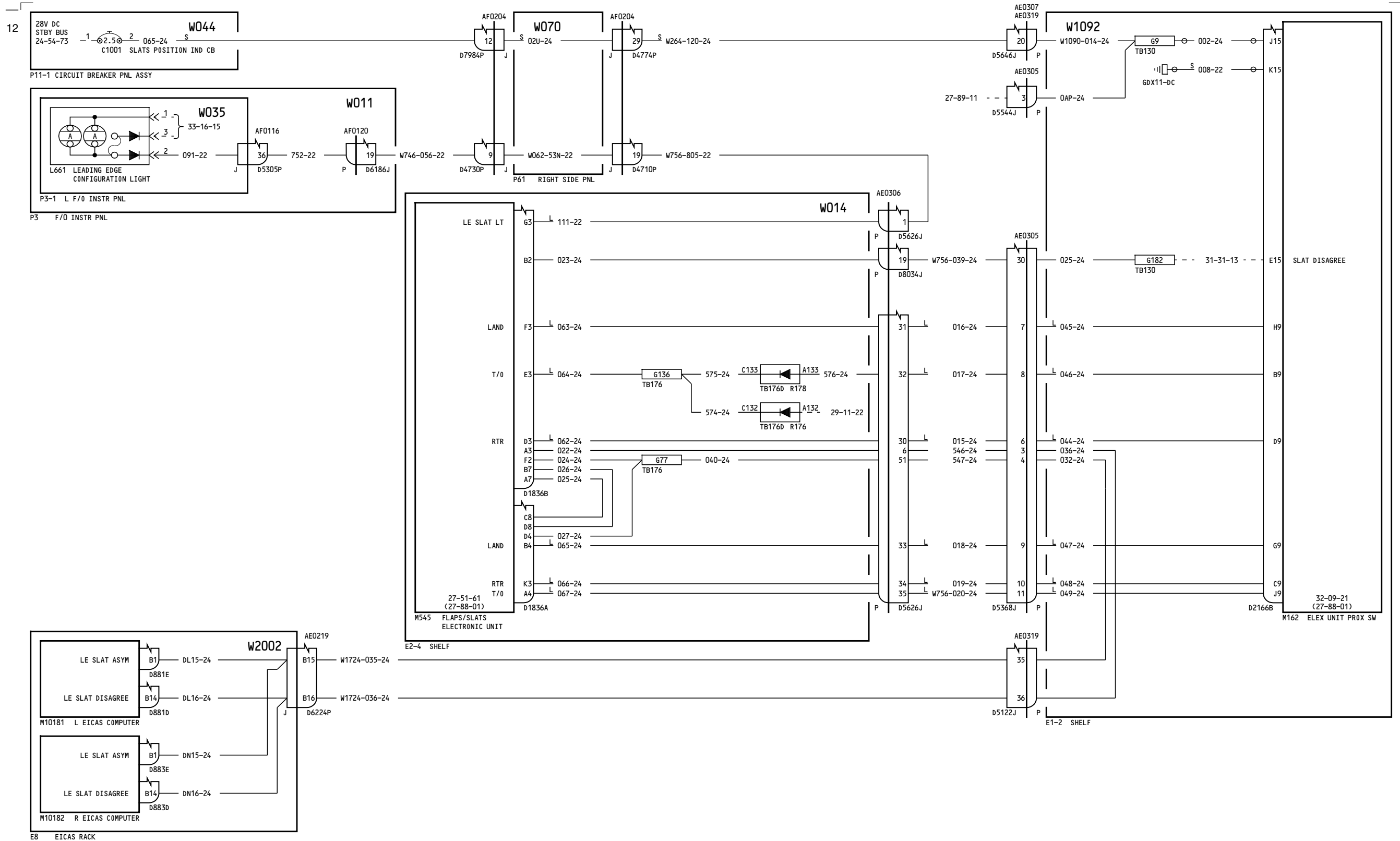

150-278

**LEADING EDGE SLAT POSITION INDICATION- LEFT WING**

**27-88-11**

Incorporates  
▶ 27A0140

**27-88-11**

Page 2.1

Page 2.1

D280T132

Jan 21/2005

Jan 21/2005



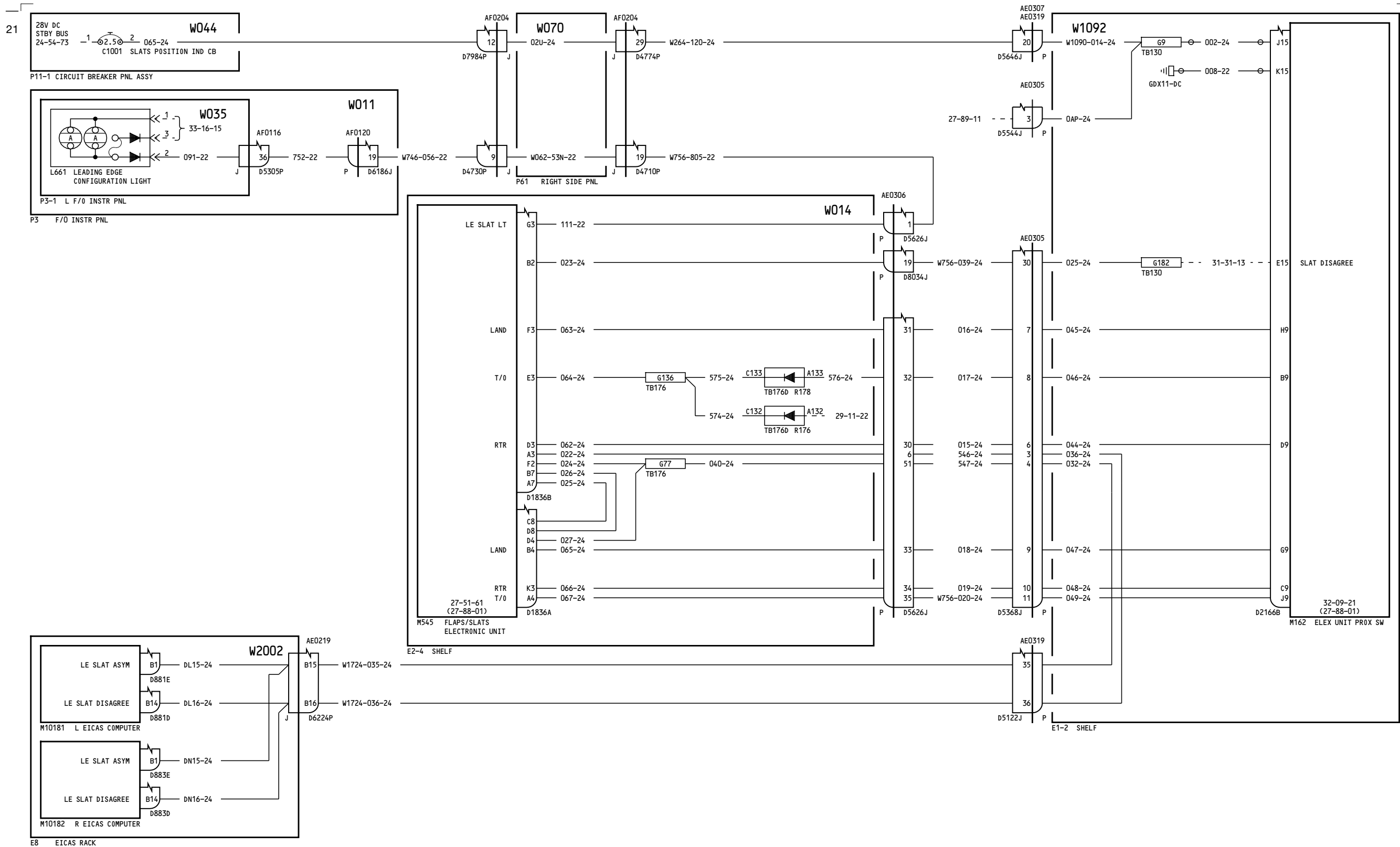

280

**LEADING EDGE SLAT  
POSITION INDICATION-  
LEFT WING**

D280T132

**27-88-11**

Page 3.1

Jan 21/2005

Incorporates  
27A0140 R01

**27-88-11**

Page 3.1

Jan 21/2005

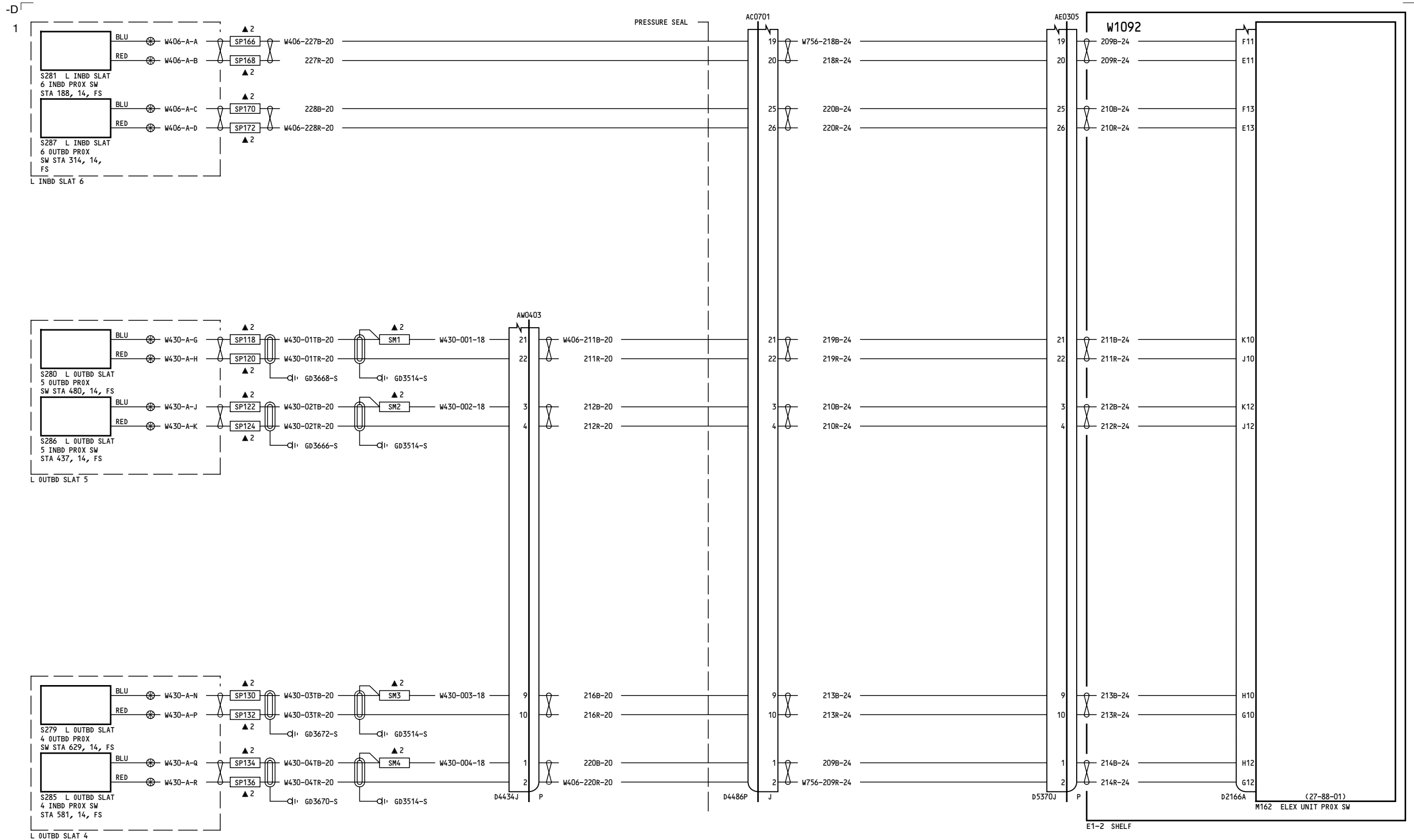

ALL

**LEADING EDGE SLAT  
POSITION SWITCHES-  
LEFT WING**

D280T132

**27-88-12**

Page 1  
Sheet 1  
Jan 21/2005

**27-88-12**

Page 1  
Sheet 1  
Jan 21/2005

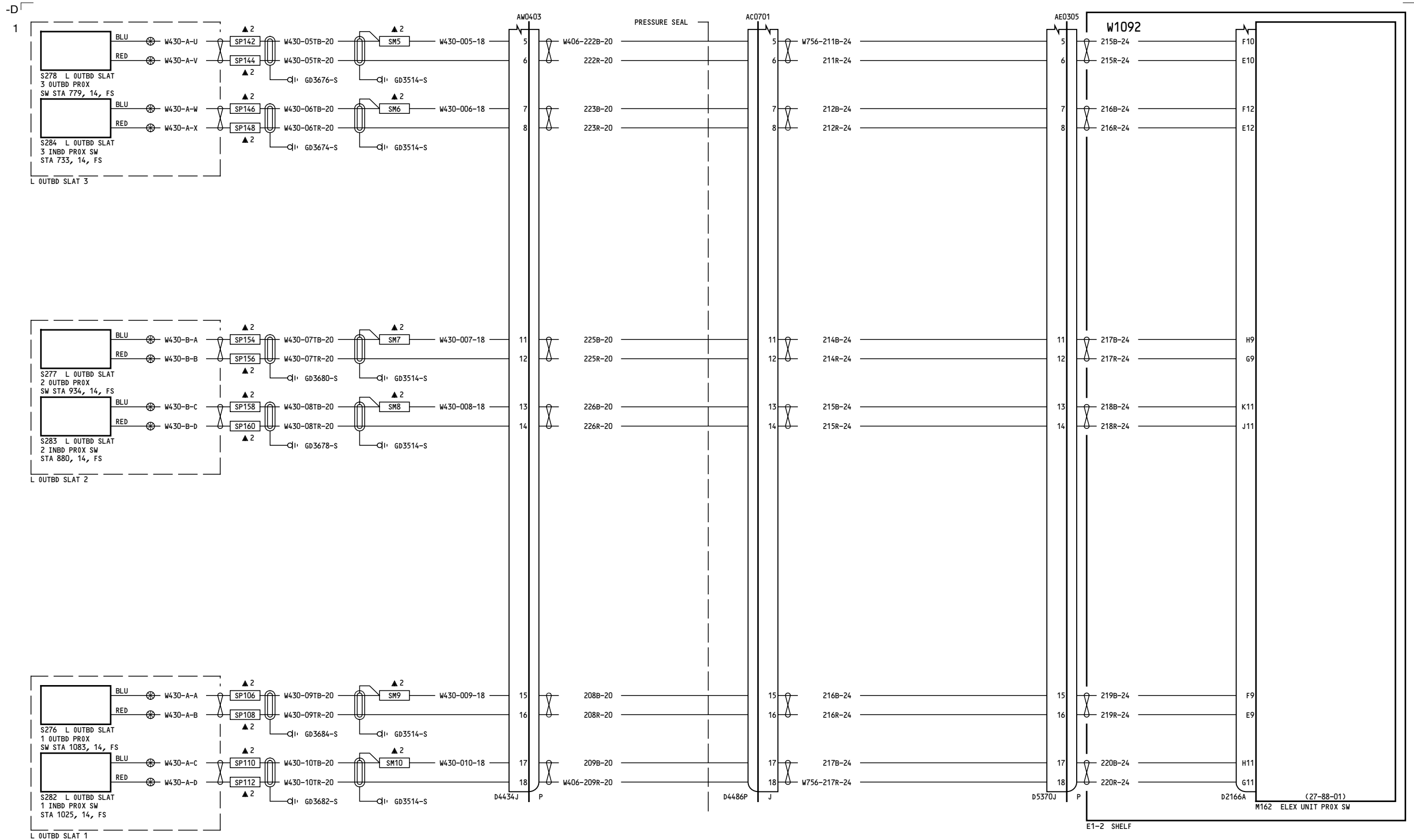

ALL

**LEADING EDGE SLAT  
POSITION SWITCHES-  
LEFT WING**

D280T132

**27-88-12**

Page 1  
Sheet 2  
Jan 21/2005

**27-88-12**

Page 1  
Sheet 2  
Jan 21/2005

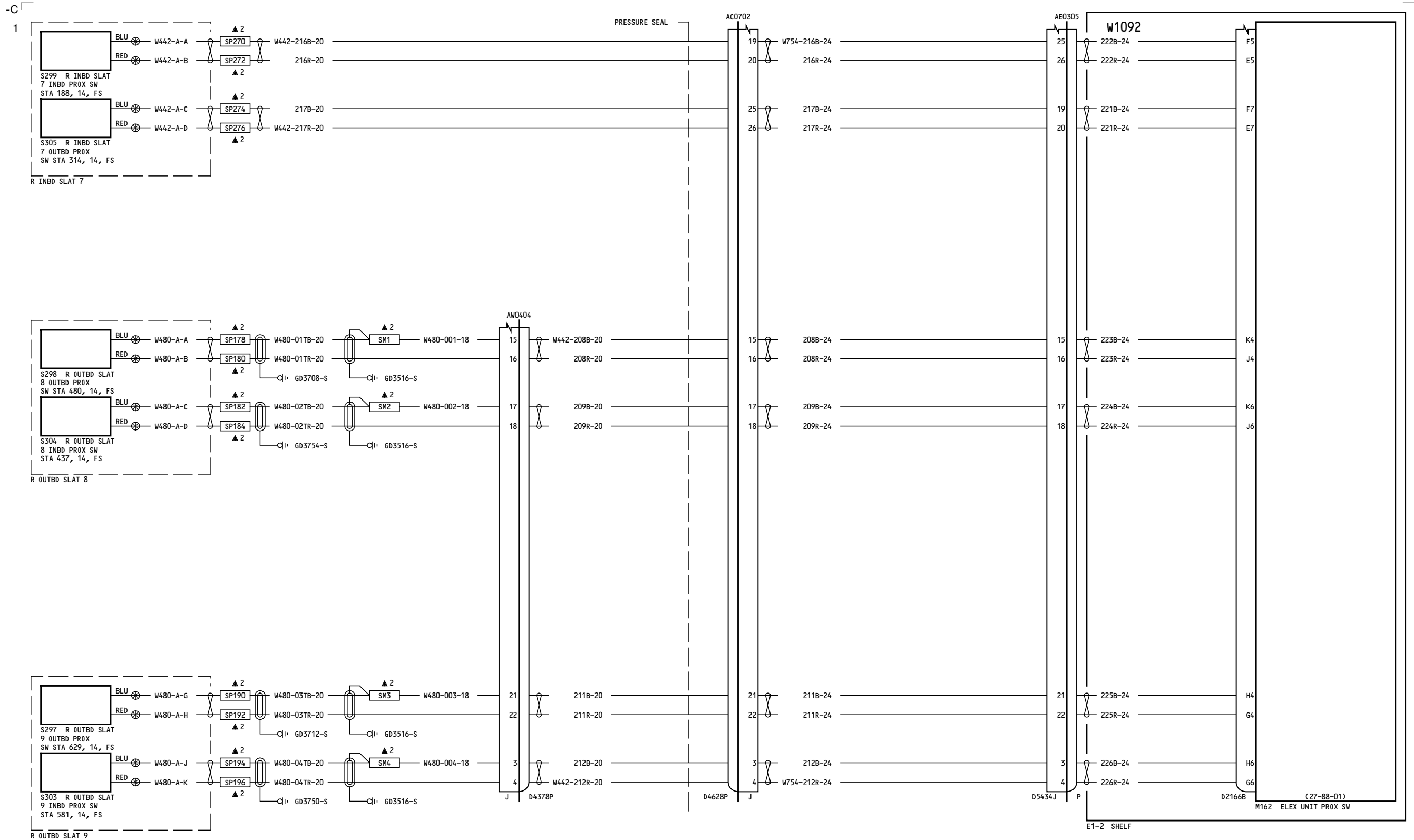

ALL

**LEADING EDGE SLAT  
POSITION SWITCHES-  
RIGHT WING**

D280T132

**27-88-22**

Page 1  
Sheet 1  
Jan 21/2005

**27-88-22**

Page 1  
Sheet 1  
Jan 21/2005

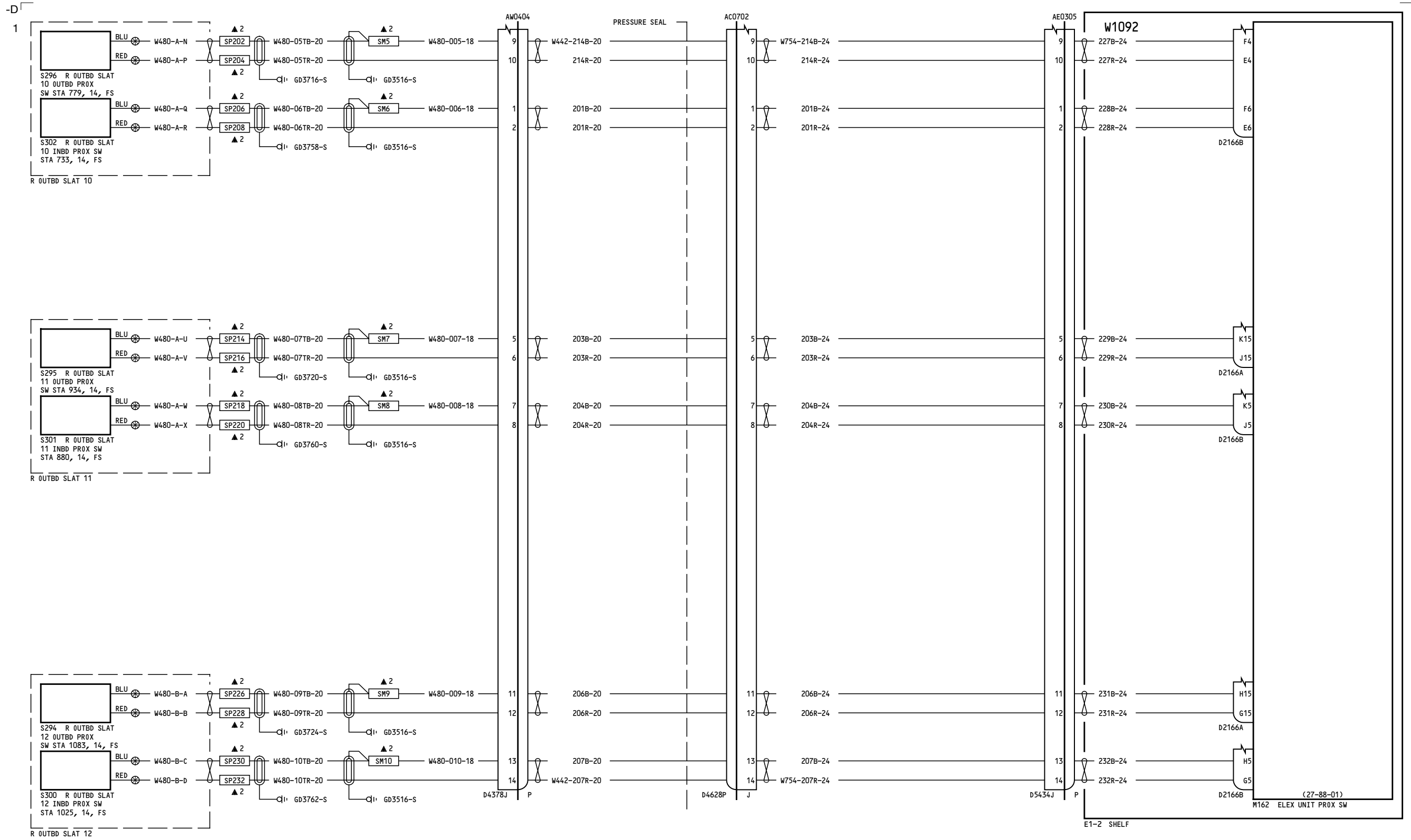

ALL

**LEADING EDGE SLAT  
POSITION SWITCHES-  
RIGHT WING**

D280T132

**27-88-22**

Page 1  
Sheet 2  
Jan 21/2005

**27-88-22**

Page 1  
Sheet 2  
Jan 21/2005

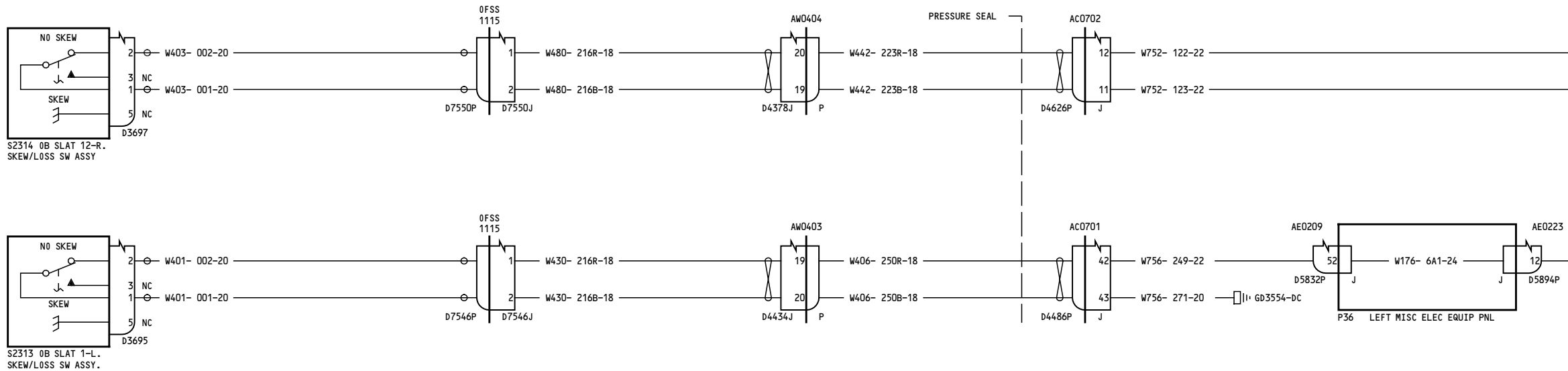
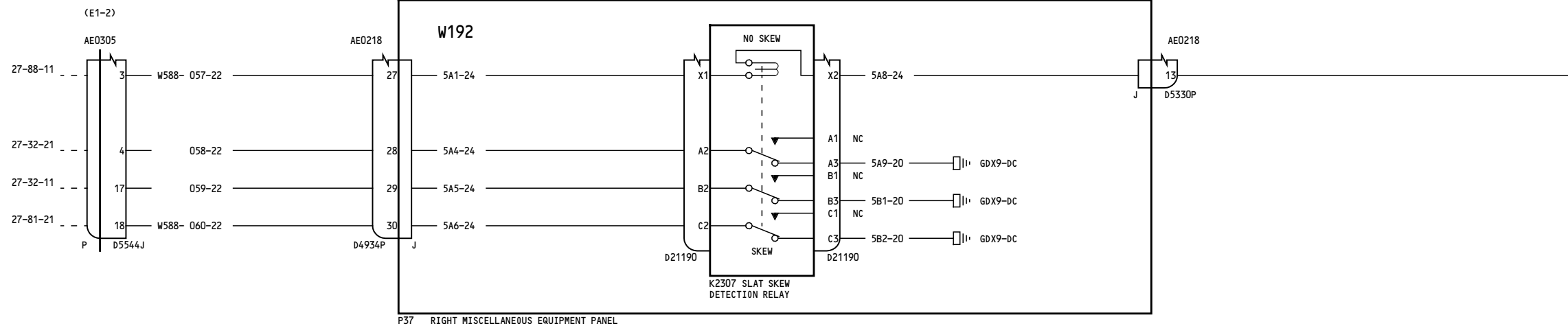

050-099

**LEADING EDGE SLAT  
SKEW DETECTION**

**27-89-11**

Page 1

D280T132

Jan 21/2005

**27-89-11**

Page 1

Jan 21/2005

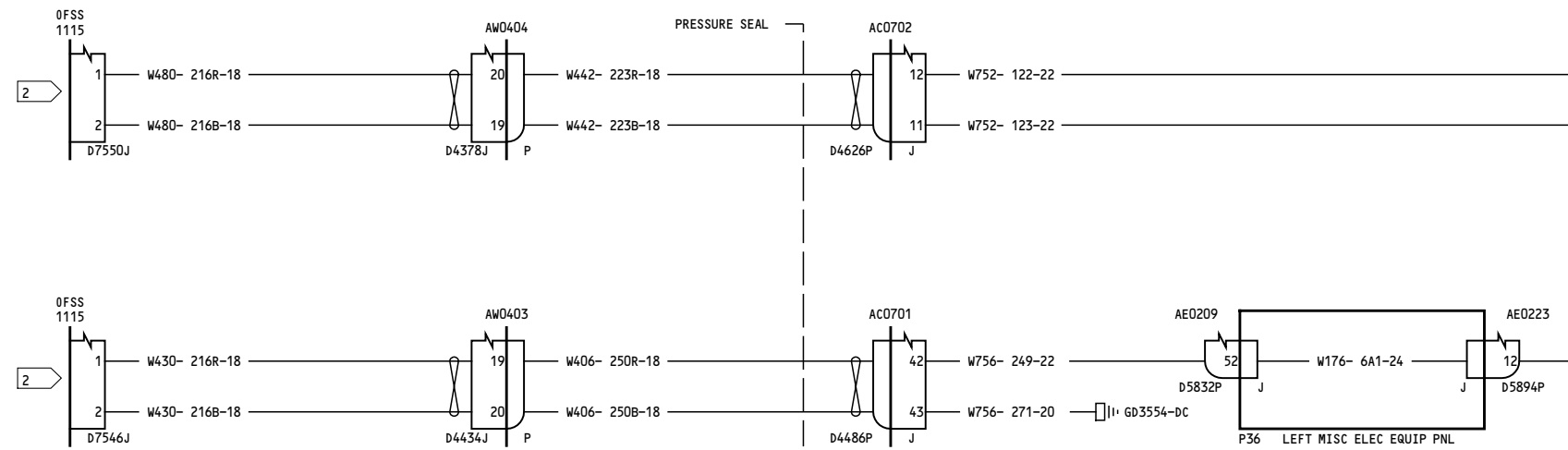
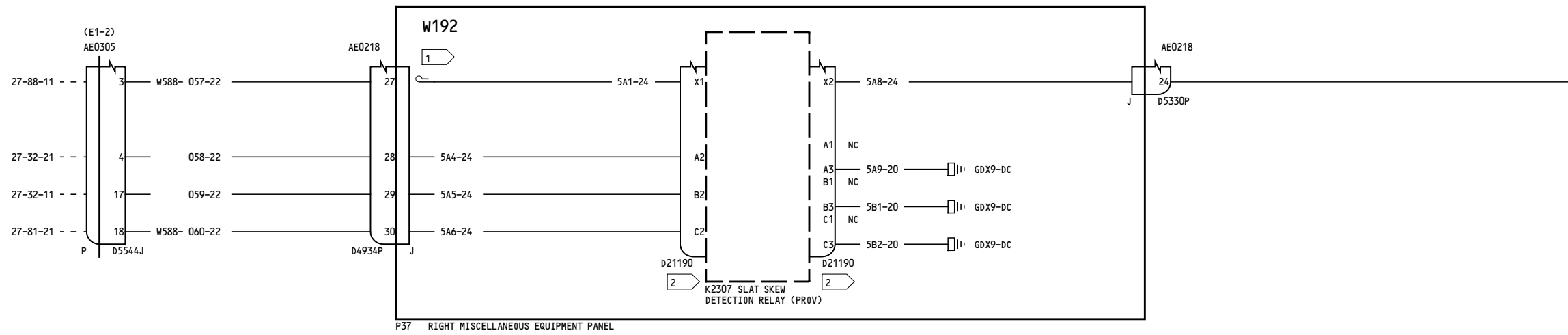

- NOTES:
- 1 CAP & STOW NEAR D4934J
  - 2 CAP AND STOW WHEN MATING EQUIPMENT NOT INSTALLED

150, 152-157, 275-278

**LEADING EDGE SLAT  
SKEW DETECTION**

D280T132

**27-89-11**

Page 2.1

Jan 21/2005

- Incorporates
- 27-0165
  - 27A0140
  - 27A0140 R01

**27-89-11**

Page 2.1

Jan 21/2005

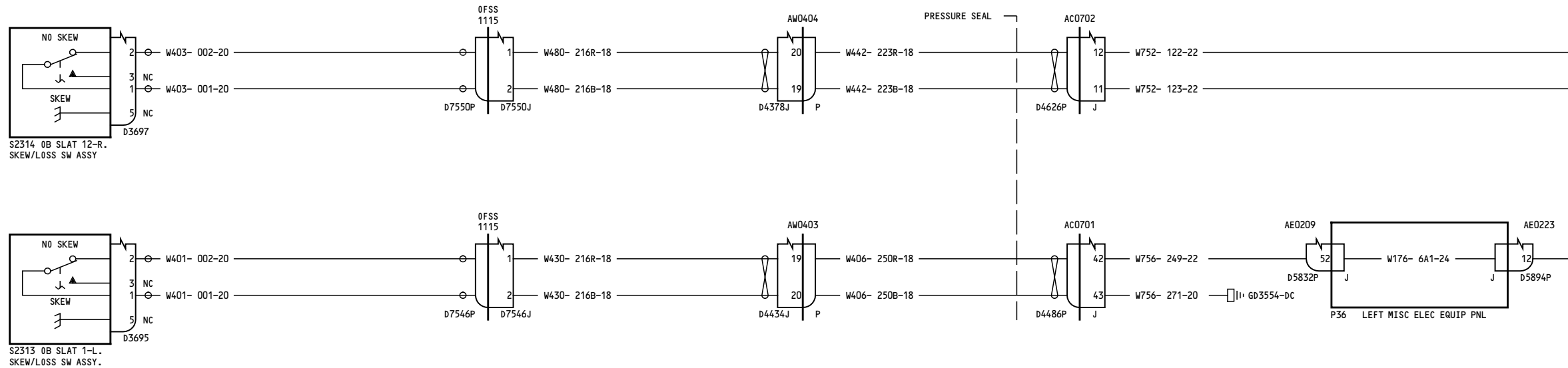
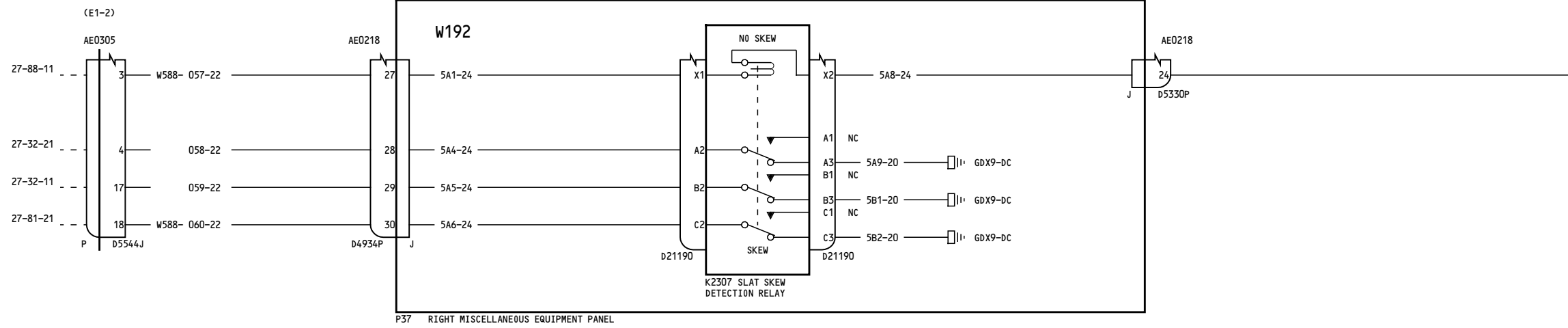



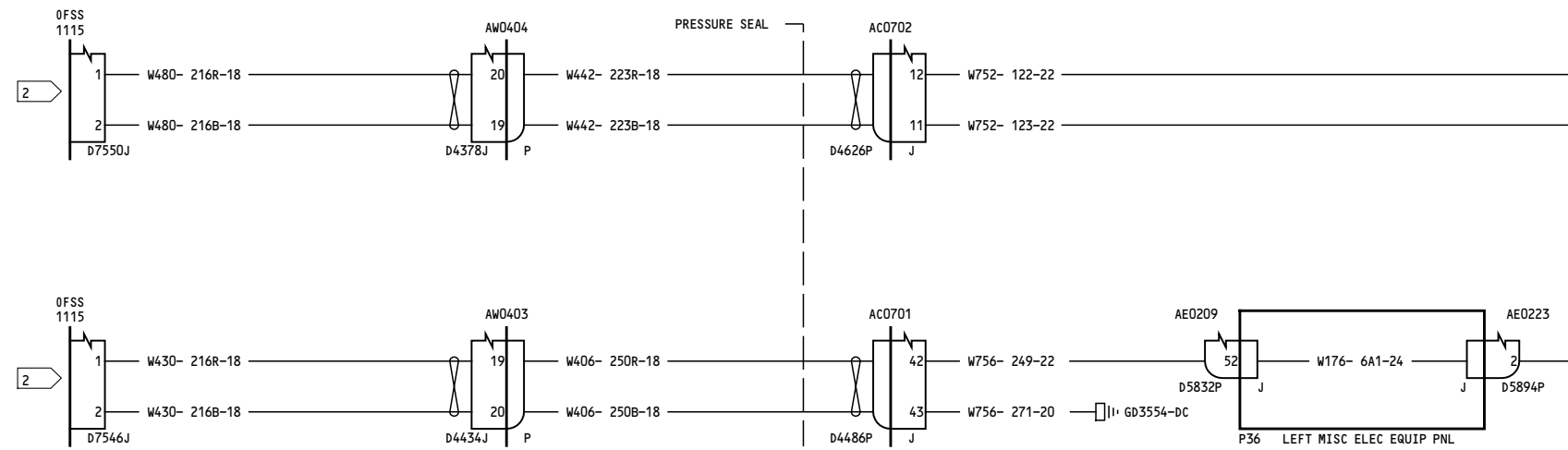
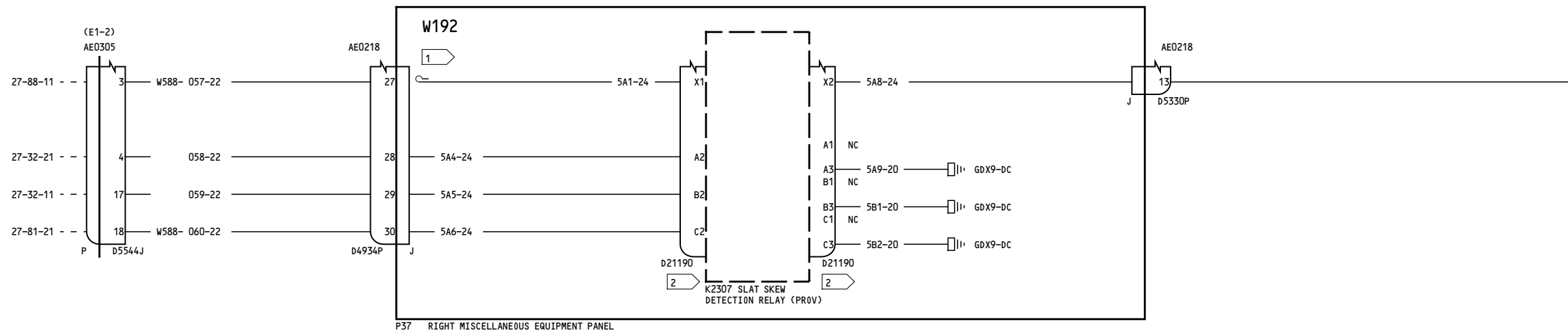

- NOTES:
- 1 CAP & STOW NEAR D4934J
  - 2 CAP AND STOW WHEN MATING EQUIPMENT NOT INSTALLED

162-167

**LEADING EDGE SLAT  
SKEW DETECTION**

D280T132

**27-89-11**

Page 4.1

Jan 21/2005

Incorporates  
 27-0165  
 27A0140

**27-89-11**

Page 4.1

Jan 21/2005

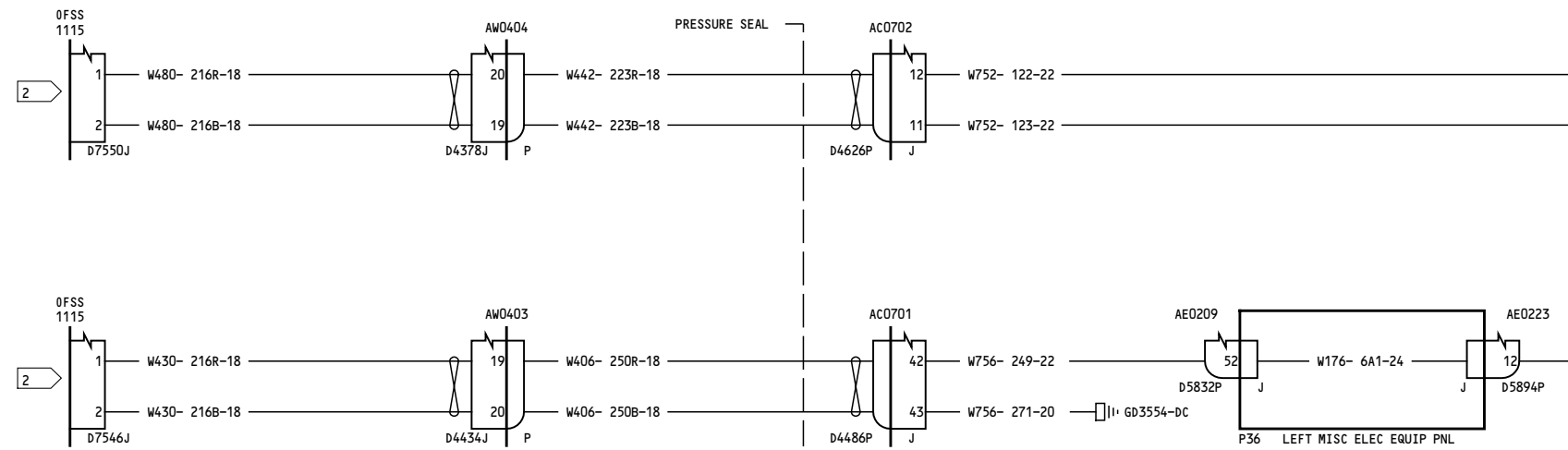
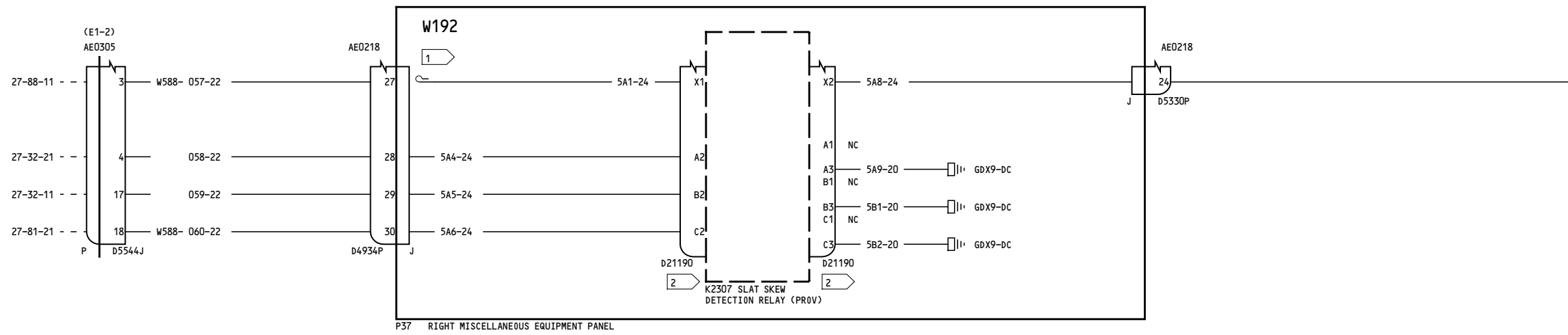

- NOTES:
- 1 CAP & STOW NEAR D4934J
  - 2 CAP AND STOW WHEN MATING EQUIPMENT NOT INSTALLED

280	<p><b>LEADING EDGE SLAT SKEW DETECTION</b></p> <p>D280T132</p>
-----	--

**27-89-11**  
Page 5.1  
Jan 21/2005

Incorporates  
27-0165  
27A0140 R01

**27-89-11**  
Page 5.1  
Jan 21/2005