

**CHAPTER**

**28**

**FUEL**



767-200/300

WIRING DIAGRAM MANUAL

CHAPTER 28  
FUEL

CH-SC-SU	Schem	Page	Sheet	Date	CH-SC-SU	Schem	Page	Sheet	Date
28-EFFECTIVE PAGES					28-22-21 (cont.)				
		1 thru 2		Aug 05/2009			1.1	1	Mar 14/2007
28-CONTENTS								2	Mar 14/2007
R		1		Aug 05/2009			2		Mar 09/2006
R		2		Aug 05/2009			2.1	1	Mar 14/2007
		3		Feb 06/2009				2	Mar 14/2007
		4		Feb 06/2009	28-22-31				
		5		Feb 06/2009			1		Jan 21/2005
		6		BLANK			1.1	1	Jan 21/2005
28-ALPHABETICAL INDEX								2	Jan 21/2005
		1		Jan 21/2005					Jan 21/2005
		2		BLANK			3		Jan 21/2005
28-21-11					28-25-11				
		1	1	Jun 06/2008			1		Jan 21/2005
			2	Jun 06/2008			1.1		Jan 21/2005
		1.1	1	Jun 06/2008			2		Jan 21/2005
			2	Jan 21/2005			2.1		Jan 21/2005
		2	1	Jan 21/2005			3		Jan 21/2005
			2	Jan 21/2005			3.1		Jan 21/2005
28-21-12					28-25-21				
		1		Jun 06/2008			1		Jan 21/2005
28-21-13							2		Jan 21/2005
		1	1	Jun 06/2008			3		Jan 21/2005
			2	Jun 06/2008	28-25-31				
28-22-11							1.1		Jan 21/2005
		1	1	Jan 21/2005			2.1		Jan 21/2005
			2	Jan 21/2005			3.1		Jan 21/2005
		1.1	1	Jan 21/2005			4.1		Jan 21/2005
			2	Jan 21/2005	28-26-11				
		2	1	Jan 21/2005			1	1	Jan 21/2005
			2	Jan 21/2005				2	Jan 21/2005
		2.1	1	Jan 21/2005			2	1	Jan 21/2005
			2	Jan 21/2005				2	Jan 21/2005
28-22-12					28-31-11				
		1	1	Jan 21/2005			1	1	Jan 21/2005
			2	Jan 21/2005				2	Jan 21/2005
R		1.1	1	Aug 05/2009			2.1	1	Jan 21/2005
			2	Feb 06/2009				2	Jan 21/2005
R		1.2	1	Aug 05/2009			3	1	Jan 21/2005
			2	Feb 06/2009				2	Jan 21/2005
R		1.3	1	Aug 05/2009			4	1	Jan 21/2005
			2	Feb 06/2009				2	Jan 21/2005
R		1.4	1	Aug 05/2009			5	1	Jan 21/2005
			2	Feb 06/2009				2	Jan 21/2005
		2	1	Jan 21/2005			6	1	Jan 21/2005
			2	Jan 21/2005				2	Jan 21/2005
R		2.1	1	Aug 05/2009	28-31-12				
			2	Feb 06/2009			1	1	Jan 21/2005
R		2.2	1	Aug 05/2009				2	Jan 21/2005
			2	Feb 06/2009			2.1	1	Jan 21/2005
28-22-21								2	Jan 21/2005
		1		Jan 21/2005			3	1	Jan 21/2005

A = Added, R = Revised, D = Deleted, O = Overflow

28-EFFECTIVE PAGES

Page 1  
Aug 05/2009

D280T132



767-200/300

WIRING DIAGRAM MANUAL

CHAPTER 28  
FUEL

CH-SC-SU	Schem	Page	Sheet	Date	CH-SC-SU	Schem	Page	Sheet	Date
28-31-12 (cont.)		3			28-42-13 (cont.)		1		
			2	Jan 21/2005				2	Jan 21/2005
	3.1		1	Jan 21/2005			2	1	Jan 21/2005
			2	Jan 21/2005				2	Jan 21/2005
	4		1	Jan 21/2005		2.1		1	Jan 21/2005
			2	Jan 21/2005				2	Jan 21/2005
	4.1		1	Jan 21/2005	28-42-21				
			2	Jan 21/2005			1		Jan 21/2005
	5		1	Jan 21/2005	28-42-31				
			2	Jan 21/2005			1		Jan 21/2005
28-31-21							1.1		Jan 21/2005
	1		1	Jan 21/2005			2		Jan 21/2005
			2	Jan 21/2005			2.1		Jan 21/2005
	2		1	Jan 21/2005	28-43-11				
			2	Jan 21/2005			1		Jan 21/2005
	2.1		1	Jan 21/2005					
			2	Jan 21/2005					
28-41-11									
	1		1	Jan 21/2005					
			2	Jan 21/2005					
	2		1	Jan 21/2005					
			2	Jan 21/2005					
	2.1		1	Mar 14/2007					
			2	Jan 21/2005					
	3		1	Jan 21/2005					
			2	Jan 21/2005					
	4		1	Jan 21/2005					
			2	Jan 21/2005					
	5		1	Jan 21/2005					
			2	Jan 21/2005					
28-41-12									
	1			Jan 21/2005					
28-41-13									
	1			Jan 21/2005					
	2			Jan 21/2005					
28-41-21									
	1			Jan 21/2005					
28-41-22									
	1			Jan 21/2005					
28-41-23									
	1			Jan 21/2005					
28-42-11									
	1			Jan 21/2005					
	2			Jan 21/2005					
28-42-12									
	1			Jan 21/2005					
	1.1			Feb 06/2009					
	2			Jan 21/2005					
	2.1			Feb 06/2009					
	3			Jan 21/2005					
28-42-13									
	1		1	Jan 21/2005					

A = Added, R = Revised, D = Deleted, O = Overflow

**28-EFFECTIVE PAGES**

Page 2  
Aug 05/2009

D280T132



767-200/300

WIRING DIAGRAM MANUAL

CHAPTER 28  
FUEL

Title	CH-SC-SU	Schem	Page	Sheet	Date	Effectivity
<b><u>PRESSURE FUELING SYSTEM</u></b>						
FUELING CONTROL	28-21-11		1	1	Jun 06/2008	050-099 150-156 162-166 275-276
				2	Jun 06/2008	050-099 150-156 162-166 275-276
			1.1	1	Jun 06/2008	050-156 162-166 275-276
				2	Jan 21/2005	050-156 162-166 275-276
			2	1	Jan 21/2005	157 167-199 277-299
				2	Jan 21/2005	157 167-199 277-299
FUEL OVERFILL SHUTOFF CONTROL	28-21-12		1		Jun 06/2008	ALL
FUELING SHUTOFF VALVES	28-21-13		1	1	Jun 06/2008	ALL
				2	Jun 06/2008	ALL
<b><u>ENGINE FUEL FEED SYSTEM</u></b>						
FUEL BOOST PUMPS- MAIN TANKS	28-22-11		1	1	Jan 21/2005	050-099 150-156 162-166 275-276
				2	Jan 21/2005	050-099 150-156 162-166 275-276
			1.1	1	Jan 21/2005	050-156 162-166 275-276
				2	Jan 21/2005	050-156 162-166 275-276
			2	1	Jan 21/2005	157 167-199 277-299
				2	Jan 21/2005	157 167-199 277-299
			2.1	1	Jan 21/2005	157 167 277-280
				2	Jan 21/2005	157 167 277-280
FUEL OVERRIDE BOOST PUMPS- AUXILIARY TANKS	28-22-12		1	1	Jan 21/2005	050-099 155-199 276-299
				2	Jan 21/2005	050-099 155-199 276-299
			1.1	1	Aug 05/2009	050-051 276-278
				2	Feb 06/2009	050-051 276-278
			1.2	1	Aug 05/2009	155-157
				2	Feb 06/2009	155-157
			1.3	1	Aug 05/2009	162-167
				2	Feb 06/2009	162-167
			1.4	1	Aug 05/2009	280
				2	Feb 06/2009	280

**28-CONTENTS**

Page 1  
Aug 05/2009

D280T132



767-200/300

WIRING DIAGRAM MANUAL

CHAPTER 28  
FUEL

Title	CH-SC-SU	Schem	Page	Sheet	Date	Effectivity
FUEL OVERRIDE BOOST PUMPS- AUXILIARY TANKS (cont.)	28-22-12		2	1	Jan 21/2005	150-154 275
				2	Jan 21/2005	150-154 275
		2.1	1	Aug 05/2009	150-154	
			2	Feb 06/2009	150-154	
		2.2	1	Aug 05/2009	275	
			2	Feb 06/2009	275	
SPAR FUEL SHUTOFF VALVES ENGINES	28-22-21		1		Jan 21/2005	050-099 150-156 162-166 275-276
		1.1	1	Mar 14/2007	155 163-164 275-276	
			2	Mar 14/2007	155 163-164 275-276	
		2		Mar 09/2006	157 167-199 277-299	
		2.1	1	Mar 14/2007	277-280	
			2	Mar 14/2007	277-280	
FUEL CROSSFEED VALVES	28-22-31		1		Jan 21/2005	050-099 155-156 162-166
		1.1	1	Jan 21/2005	050-280	
			2	Jan 21/2005	050-280	
		2		Jan 21/2005	150-154 275-276	
		3		Jan 21/2005	157 167-199 277-299	
<b><u>APU FUEL FEED SYSTEM</u></b>						
DC FUEL PUMP- APU	28-25-11		1		Jan 21/2005	050-099
		1.1		Jan 21/2005	050-051	
		2		Jan 21/2005	150-154 275	
		2.1		Jan 21/2005	150-154 275	
		3		Jan 21/2005	155-199 276-299	
FUEL SHUTOFF VALVE- APU	28-25-21	3.1		Jan 21/2005	155-167 276-280	
		1		Jan 21/2005	050-099	
		2		Jan 21/2005	150-156 162-166 275-276	
FUEL ISOLATION VALVE- APU	28-25-31	3		Jan 21/2005	157 167-199 277-299	
		1.1		Jan 21/2005	050-051 155-156 162-166	
		2.1		Jan 21/2005	150-154	
		3.1		Jan 21/2005	157 167 277-280	
		4.1		Jan 21/2005	275-276	

**28-CONTENTS**

Page 2

Aug 05/2009

D280T132



**767-200/300  
WIRING DIAGRAM MANUAL**

**CHAPTER 28  
FUEL**

<b>Title</b>	<b>CH-SC-SU</b>	<b>Schem</b>	<b>Page</b>	<b>Sheet</b>	<b>Date</b>	<b>Effectivity</b>			
<b><u>DEFUELING</u></b>									
DEFUELING VALVES	28-26-11		1	1	Jan 21/2005	050-099 150-156 162-166 275-276			
			2		Jan 21/2005	050-099 150-156 162-166 275-276			
			2	1	Jan 21/2005	157 167-199 277-299			
			2		Jan 21/2005	157 167-199 277-299			
<b><u>FUEL JETTISON SYSTEM</u></b>									
FUEL JETTISON TRANSFER VALVE CONTROL	28-31-11		1	1	Jan 21/2005	050			
				2	Jan 21/2005	050			
			2.1	1	Jan 21/2005	051			
				2	Jan 21/2005	051			
			3	1	Jan 21/2005	155-156 165-166			
				2	Jan 21/2005	155-156 165-166			
			4	1	Jan 21/2005	157 167-199 277-299			
				2	Jan 21/2005	157 167-199 277-299			
			5	1	Jan 21/2005	162-164			
				2	Jan 21/2005	162-164			
			6	1	Jan 21/2005	276			
				2	Jan 21/2005	276			
			FUEL JETTISON NOZZLE VALVE CONTROL	28-31-12		1	1	Jan 21/2005	050
							2	Jan 21/2005	050
2.1	1	Jan 21/2005				051			
	2	Jan 21/2005				051			
3	1	Jan 21/2005				155-156 162-166			
	2	Jan 21/2005				155-156 162-166			
3.1	1	Jan 21/2005				155-156 165-166			
	2	Jan 21/2005				155-156 165-166			
4	1	Jan 21/2005				157 167-199 277-299			
	2	Jan 21/2005				157 167-199 277-299			
4.1	1	Jan 21/2005				157 167 277-280			
	2	Jan 21/2005				157 167 277-280			
5	1	Jan 21/2005				276			



767-200/300

WIRING DIAGRAM MANUAL

CHAPTER 28  
FUEL

Title	CH-SC-SU	Schem	Page	Sheet	Date	Effectivity
FUEL JETTISON NOZZLE VALVE CONTROL (cont.)	28-31-12			2	Jan 21/2005	276
FUEL JETTISON PUMPS	28-31-21		1	1	Jan 21/2005	050-099 162-164 276
				2	Jan 21/2005	050-099 162-164 276
			2	1	Jan 21/2005	155-157 165-199 277-299
				2	Jan 21/2005	155-157 165-199 277-299
			2.1	1	Jan 21/2005	155-157 165-167 277-280
				2	Jan 21/2005	155-157 165-167 277-280
<b>FUEL QUANTITY INDICATING SYSTEM (FQIS)</b>						
FUEL QUANTITY INDICATION	28-41-11		1	1	Jan 21/2005	050-099
				2	Jan 21/2005	050-099
			2	1	Jan 21/2005	150-157
				2	Jan 21/2005	150-157
			2.1	1	Mar 14/2007	153
				2	Jan 21/2005	153
			3	1	Jan 21/2005	162-199
				2	Jan 21/2005	162-199
			4	1	Jan 21/2005	275-276
				2	Jan 21/2005	275-276
			5	1	Jan 21/2005	277-299
				2	Jan 21/2005	277-299
FUEL QUANTITY INDICATING SYSTEM POWER	28-41-12		1		Jan 21/2005	ALL
FUEL CONFIGURATION INDICATION	28-41-13		1		Jan 21/2005	050-099 150-156 162-166 275-276
				2	Jan 21/2005	157 167-199 277-299
FUEL QUANTITY SENSORS-LEFT MAIN TANK	28-41-21		1		Jan 21/2005	ALL
FUEL QUANTITY SENSORS-RIGHT MAIN TANK	28-41-22		1		Jan 21/2005	ALL
FUEL QUANTITY SENSORS-AUXILIARY TANKS	28-41-23		1		Jan 21/2005	ALL

**28-CONTENTS**



767-200/300

WIRING DIAGRAM MANUAL

CHAPTER 28  
FUEL

Title	CH-SC-SU	Schem	Page	Sheet	Date	Effectivity
<b><u>FUEL FEED LOW PRESSURE INDICATING SYSTEM</u></b>						
LOW FUEL PRESSURE INDICATOR-BOOST PUMPS	28-42-11		1		Jan 21/2005	050-099 150-154 162-165 275-276
			2		Jan 21/2005	155-157 166-199 277-299
LOW FUEL PRESSURE INDICATOR-OVERRIDE PUMPS	28-42-12		1		Jan 21/2005	050-099 276
			1.1		Feb 06/2009	050-051 155-167 276-280
			2		Jan 21/2005	150-154 275
			2.1		Feb 06/2009	150-154 275
			3		Jan 21/2005	155-199 277-299
FUEL JETTISON PUMPS LOW PRESSURE SWITCH	28-42-13		1	1	Jan 21/2005	050-099 162-164 276
				2	Jan 21/2005	050-099 162-164 276
			2	1	Jan 21/2005	155-157 165-199 277-299
				2	Jan 21/2005	155-157 165-199 277-299
			2.1	1	Jan 21/2005	155-157 165-167 277-280
				2	Jan 21/2005	155-157 165-167 277-280
FUEL PRESSURE INDICATOR- DC PUMP	28-42-21		1		Jan 21/2005	ALL
ENGINE FUEL LOW PRESSURE INDICATION	28-42-31		1		Jan 21/2005	050-099 150-154 162-165 275-276
			1.1		Jan 21/2005	050-154 162-165 275-276
			2		Jan 21/2005	155-157 166-199 277-299
			2.1		Jan 21/2005	155-157 166-167 277-280
<b><u>FUEL TEMPERATURE INDICATING SYSTEM</u></b>						
FUEL TEMPERATURE INDICATION	28-43-11		1		Jan 21/2005	ALL





767-200/300

## WIRING DIAGRAM MANUAL

### CHAPTER 28

#### FUEL

CH-SC-SU	Title
28-25-11	DC FUEL PUMP- APU
28-26-11	DEFUELING VALVES
28-42-31	ENGINE FUEL LOW PRESSURE INDICATION
28-22-11	FUEL BOOST PUMPS- MAIN TANKS
28-41-13	FUEL CONFIGURATION INDICATION
28-22-31	FUEL CROSSFEED VALVES
28-25-31	FUEL ISOLATION VALVE- APU
28-31-12	FUEL JETTISON NOZZLE VALVE CONTROL
28-31-21	FUEL JETTISON PUMPS
28-42-13	FUEL JETTISON PUMPS LOW PRESSURE SWITCH
28-31-11	FUEL JETTISON TRANSFER VALVE CONTROL
28-21-12	FUEL OVERFILL SHUTOFF CONTROL
28-22-12	FUEL OVERRIDE BOOST PUMPS- AUXILIARY TANKS
28-42-21	FUEL PRESSURE INDICATOR- DC PUMP
28-41-12	FUEL QUANTITY INDICATING SYSTEM POWER
28-41-11	FUEL QUANTITY INDICATION
28-41-23	FUEL QUANTITY SENSORS- AUXILIARY TANKS
28-41-21	FUEL QUANTITY SENSORS- LEFT MAIN TANK
28-41-22	FUEL QUANTITY SENSORS- RIGHT MAIN TANK
28-25-21	FUEL SHUTOFF VALVE- APU
28-43-11	FUEL TEMPERATURE INDICATION
28-21-11	FUELING CONTROL
28-21-13	FUELING SHUTOFF VALVES
28-42-11	LOW FUEL PRESSURE INDICATOR-BOOST PUMPS
28-42-12	LOW FUEL PRESSURE INDICATOR-OVERRIDE PUMPS
28-22-21	SPAR FUEL SHUTOFF VALVES ENGINES

## 28-ALPHABETICAL INDEX

D280T132

Page 1  
Jan 21/2005

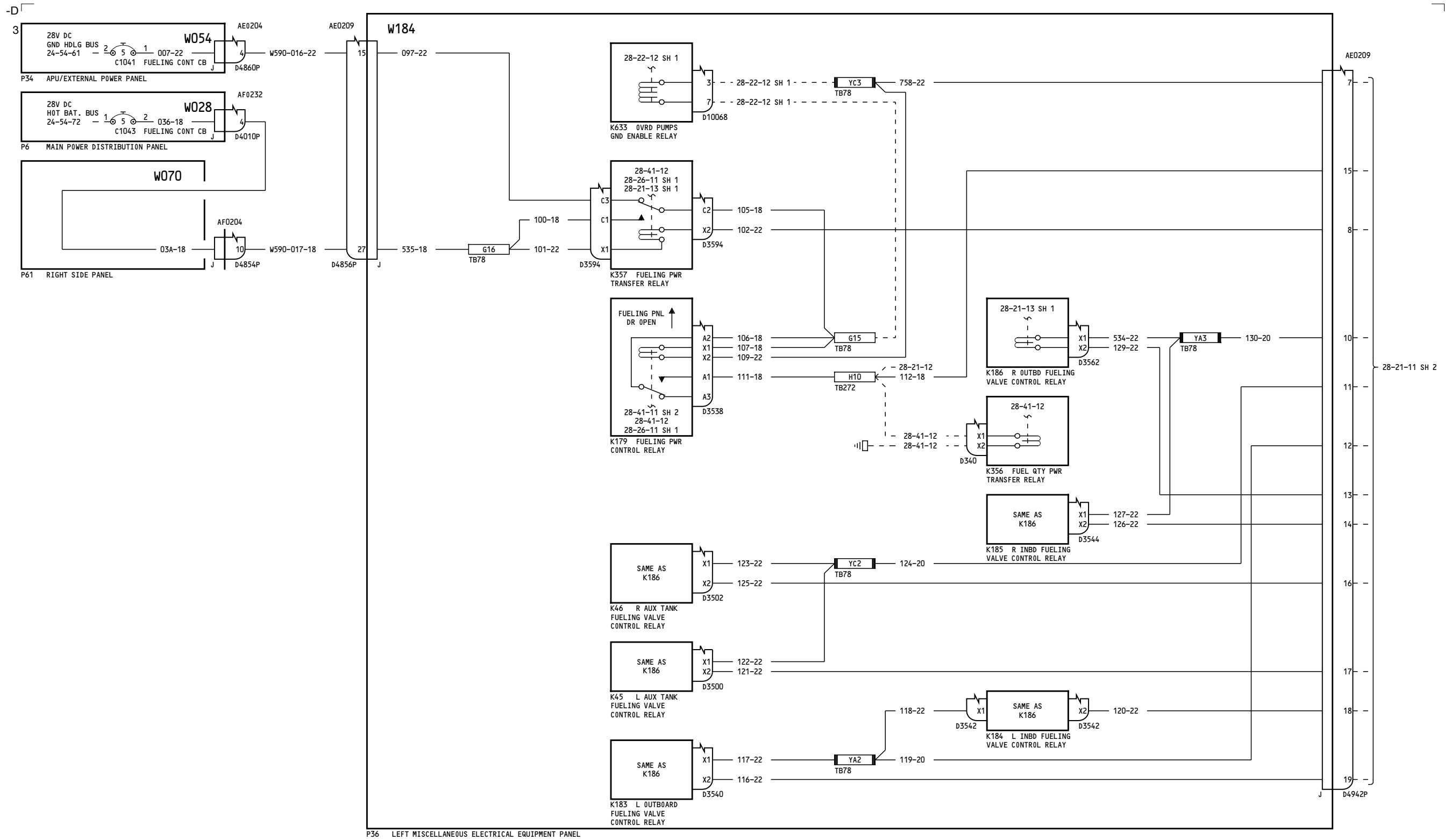

050-099, 150-156, 162-166, 275-276

**FUELING CONTROL**

**28-21-11**

Page 1  
Sheet 1  
Jun 06/2008

D280T132

**28-21-11**

Page 1  
Sheet 1  
Jun 06/2008

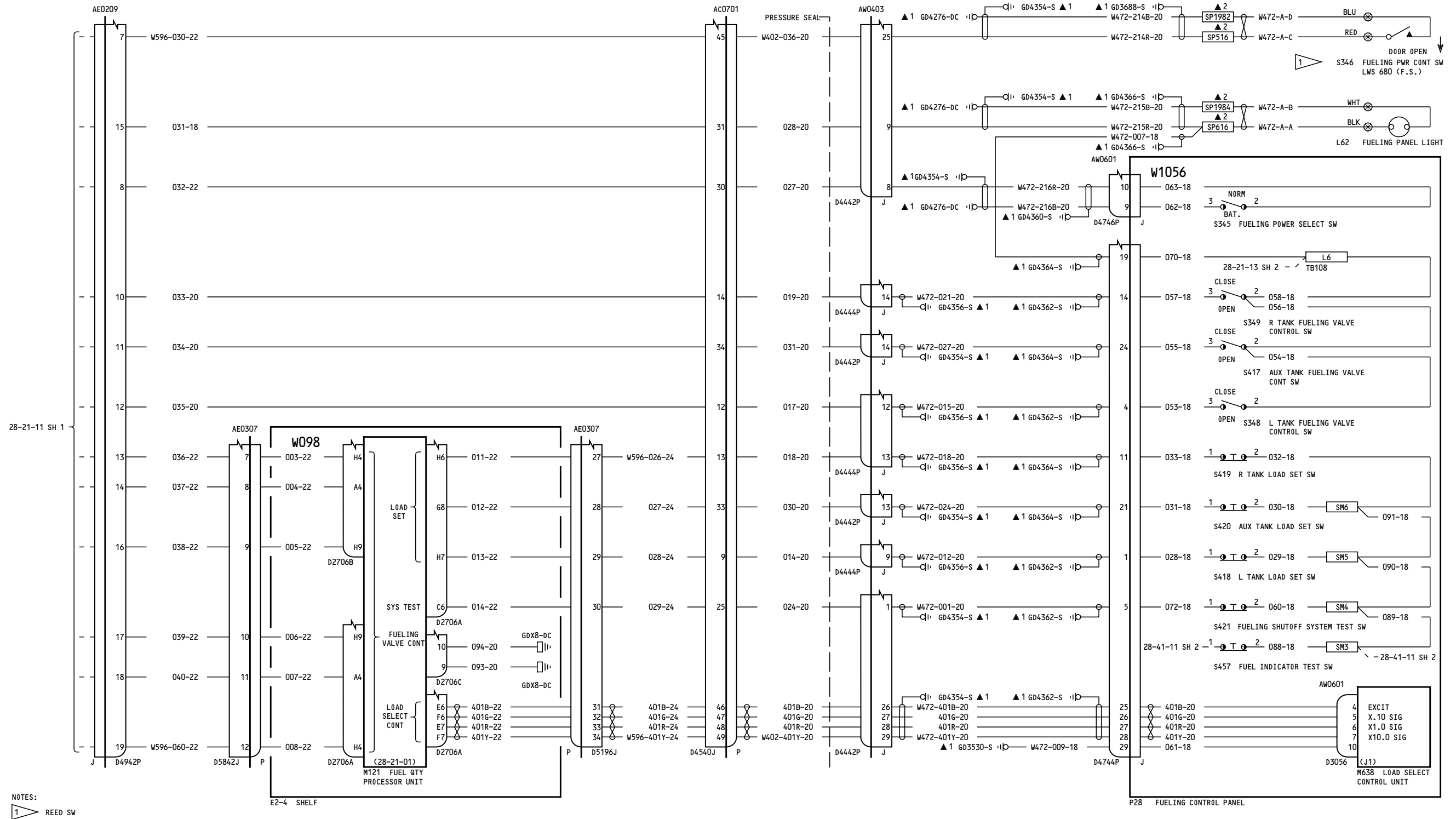

050-099, 150-156, 162-166, 275-276

**FUELING CONTROL**

D280T132

**28-21-11**

Page 1  
Sheet 2  
Jun 06/2008

**28-21-11**

Page 1  
Sheet 2  
Jun 06/2008

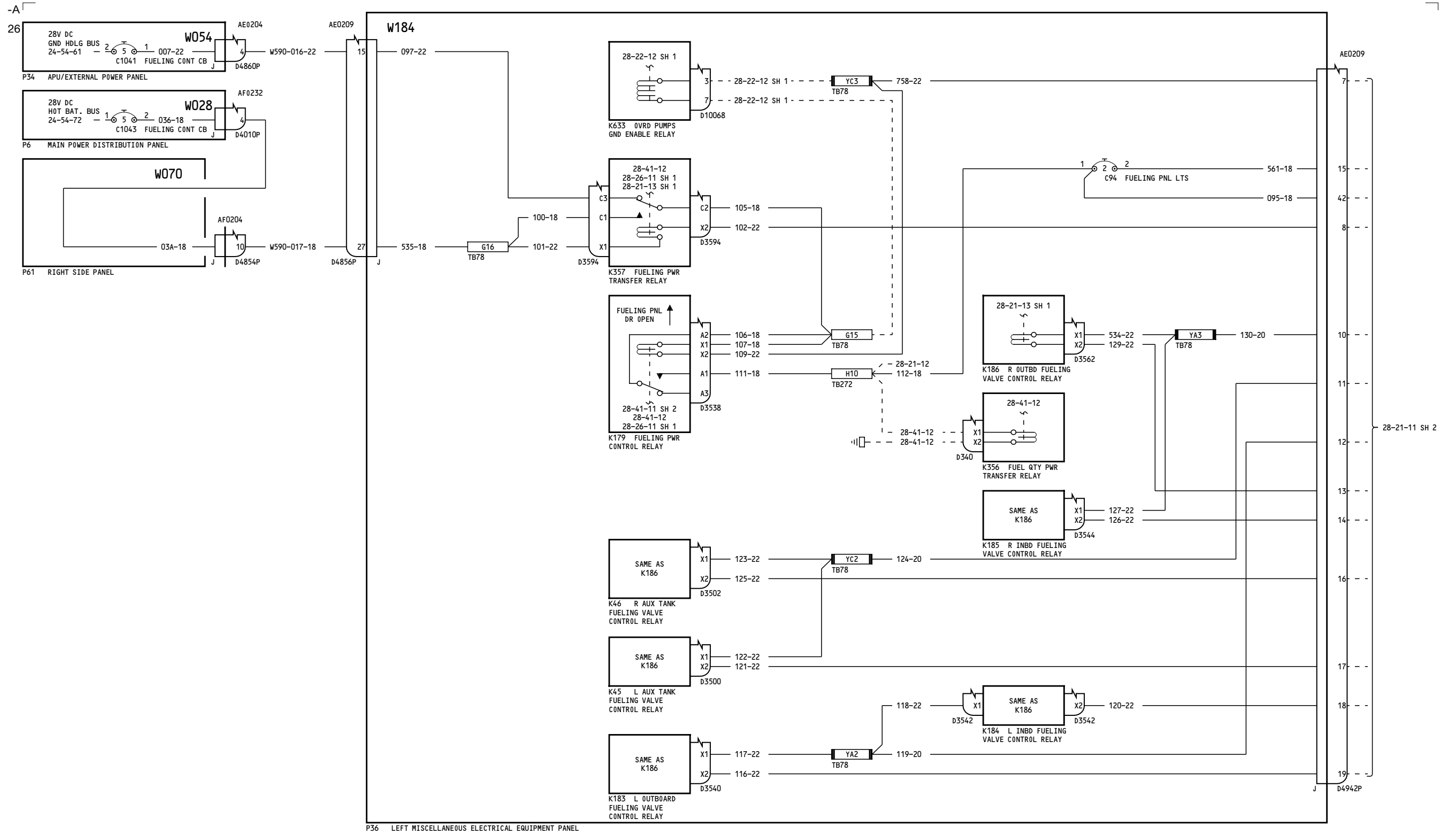

050-156, 162-166, 275-276

**FUELING CONTROL**

**28-21-11**

Page 1.1  
Sheet 1  
Jun 06/2008

D280T132

Incorporates  
28-0031

**28-21-11**

Page 1.1  
Sheet 1  
Jun 06/2008

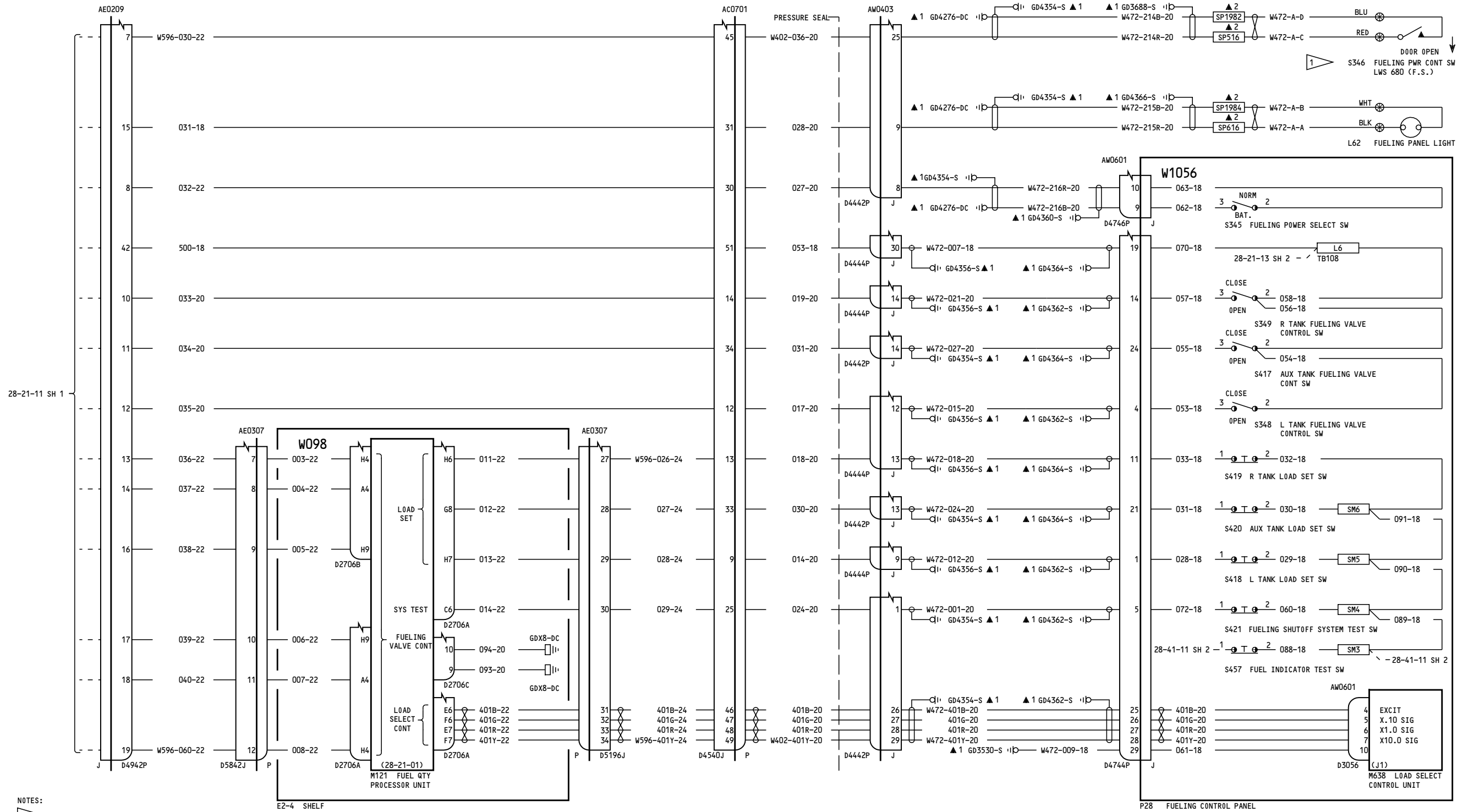

NOTES:  
1 REED SW

050-156, 162-166, 275-276

FUELING CONTROL  
D280T132

28-21-11

Page 1.1  
Sheet 2  
Jan 21/2005

Incorporates  
28-0031

28-21-11

Page 1.1  
Sheet 2  
Jan 21/2005

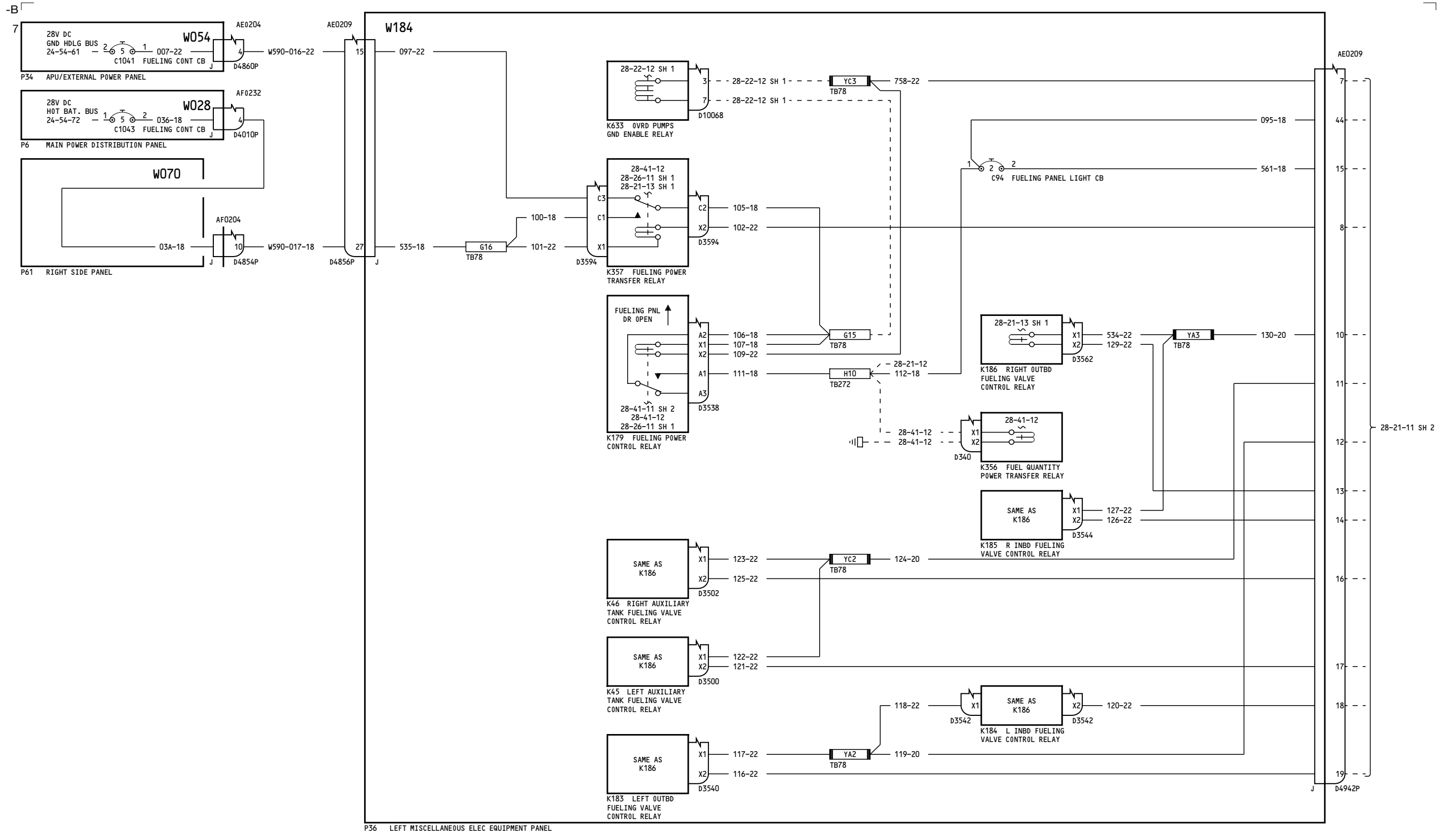

157, 167-199, 277-299

FUELING CONTROL

28-21-11

Page 2  
Sheet 1  
Jan 21/2005

D280T132

28-21-11

Page 2  
Sheet 1  
Jan 21/2005

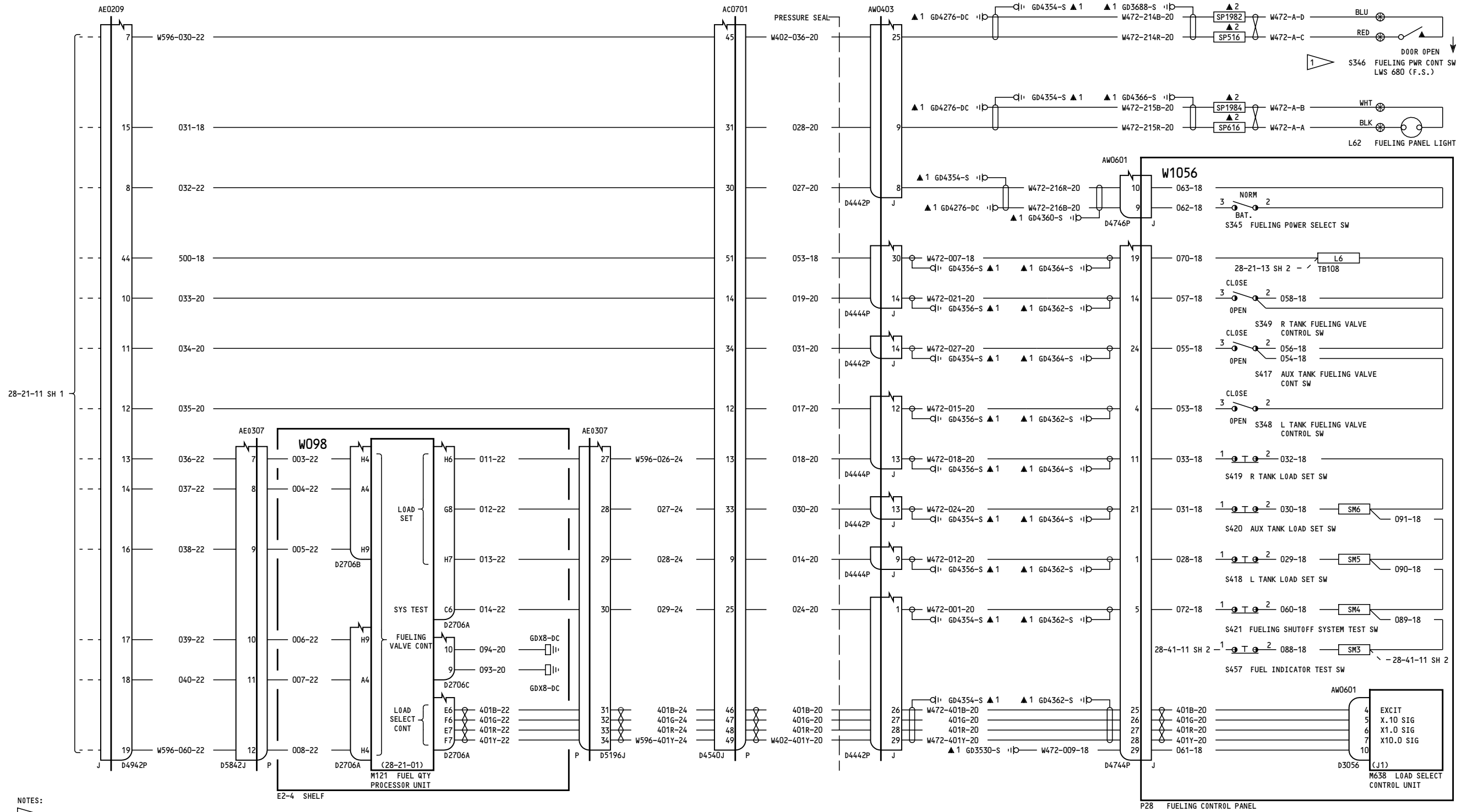

NOTES:  
1 REED SW

157, 167-199, 277-299

FUELING CONTROL

28-21-11

Page 2  
Sheet 2  
Jan 21/2005

D280T132

28-21-11

Page 2  
Sheet 2  
Jan 21/2005

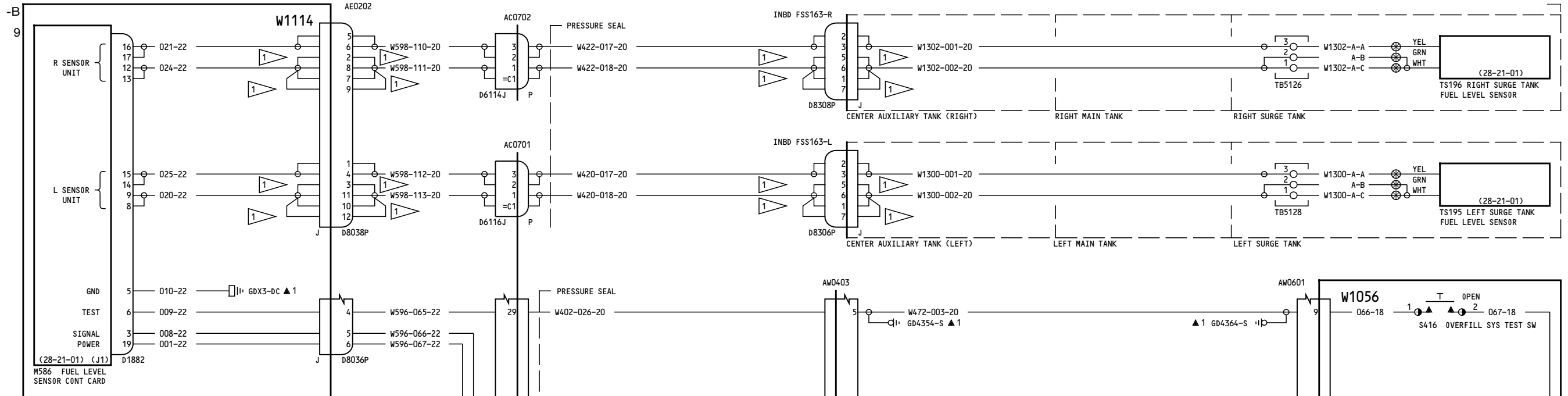

P50 ELECTRICAL SYSTEMS CARD FILE

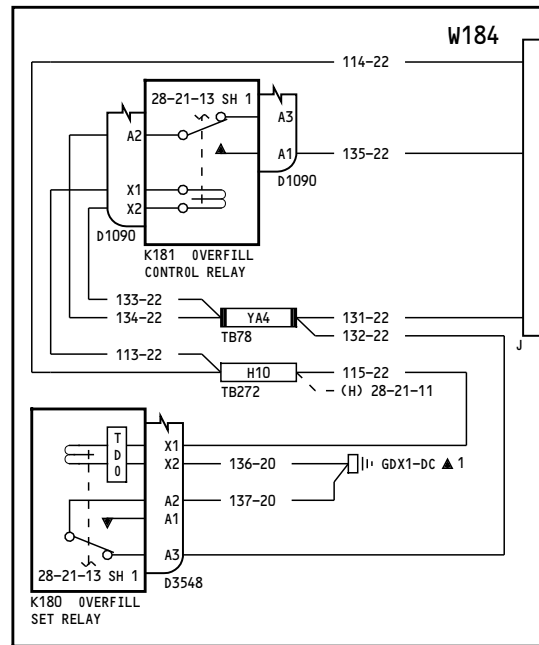

P36 LEFT MISCELLANEOUS ELECTRICAL EQUIPMENT PANEL

**NOTES:**

1 SHIELD SHALL BE WITHIN 0.25 IN. OF CONN GROMMET

ALL	<b>FUEL OVERFILL SHUTOFF CONTROL</b>
	D280T132

**28-21-12**

Page 1

Jun 06/2008

**28-21-12**

Page 1

Jun 06/2008



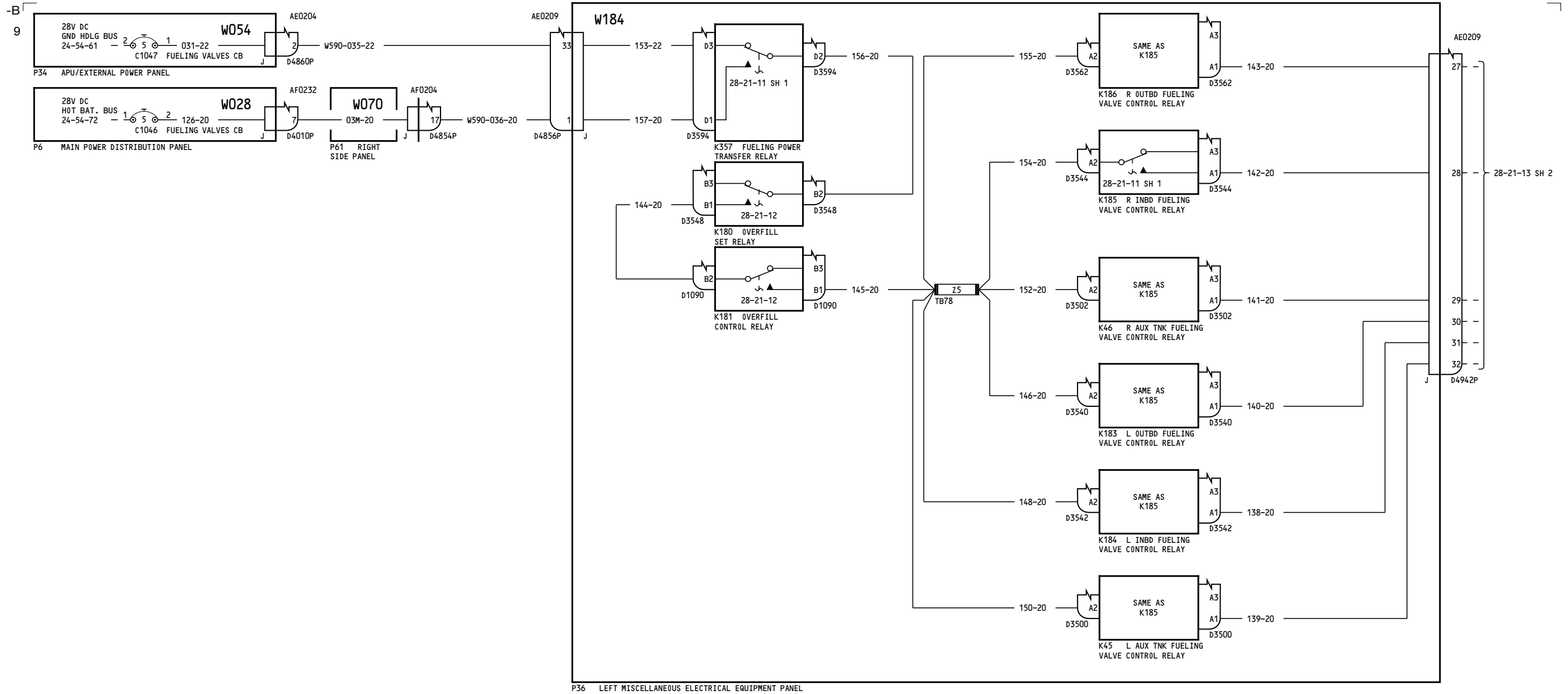

ALL	<b>FUELING SHUTOFF VALVES</b>
	D280T132

**28-21-13**

Page 1  
Sheet 1  
Jun 06/2008

**28-21-13**

Page 1  
Sheet 1  
Jun 06/2008

-B  
9

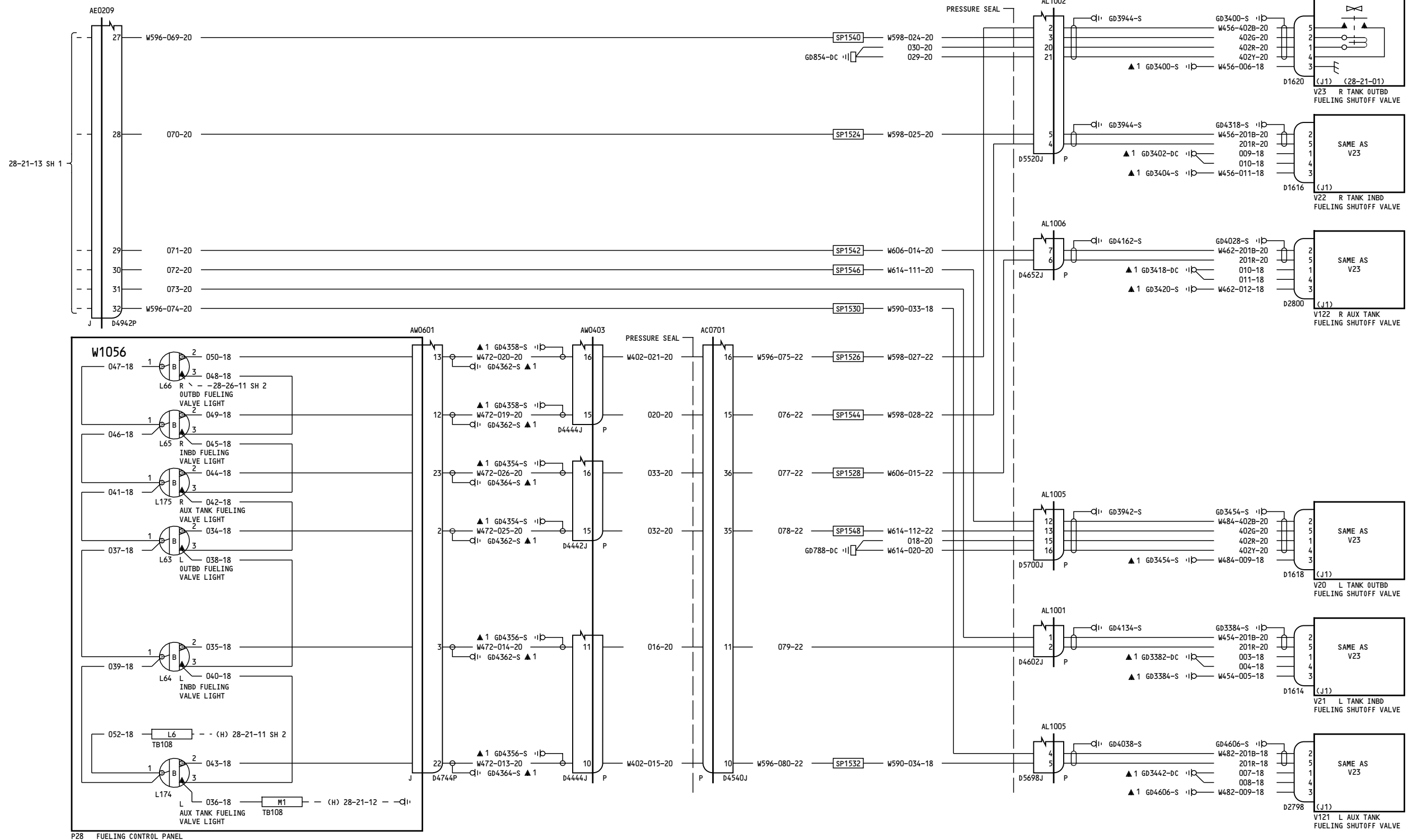

ALL

**FUELING SHUTOFF VALVES**  
  
D280T132

**28-21-13**  
Page 1  
Sheet 2  
Jun 06/2008

**28-21-13**  
Page 1  
Sheet 2  
Jun 06/2008

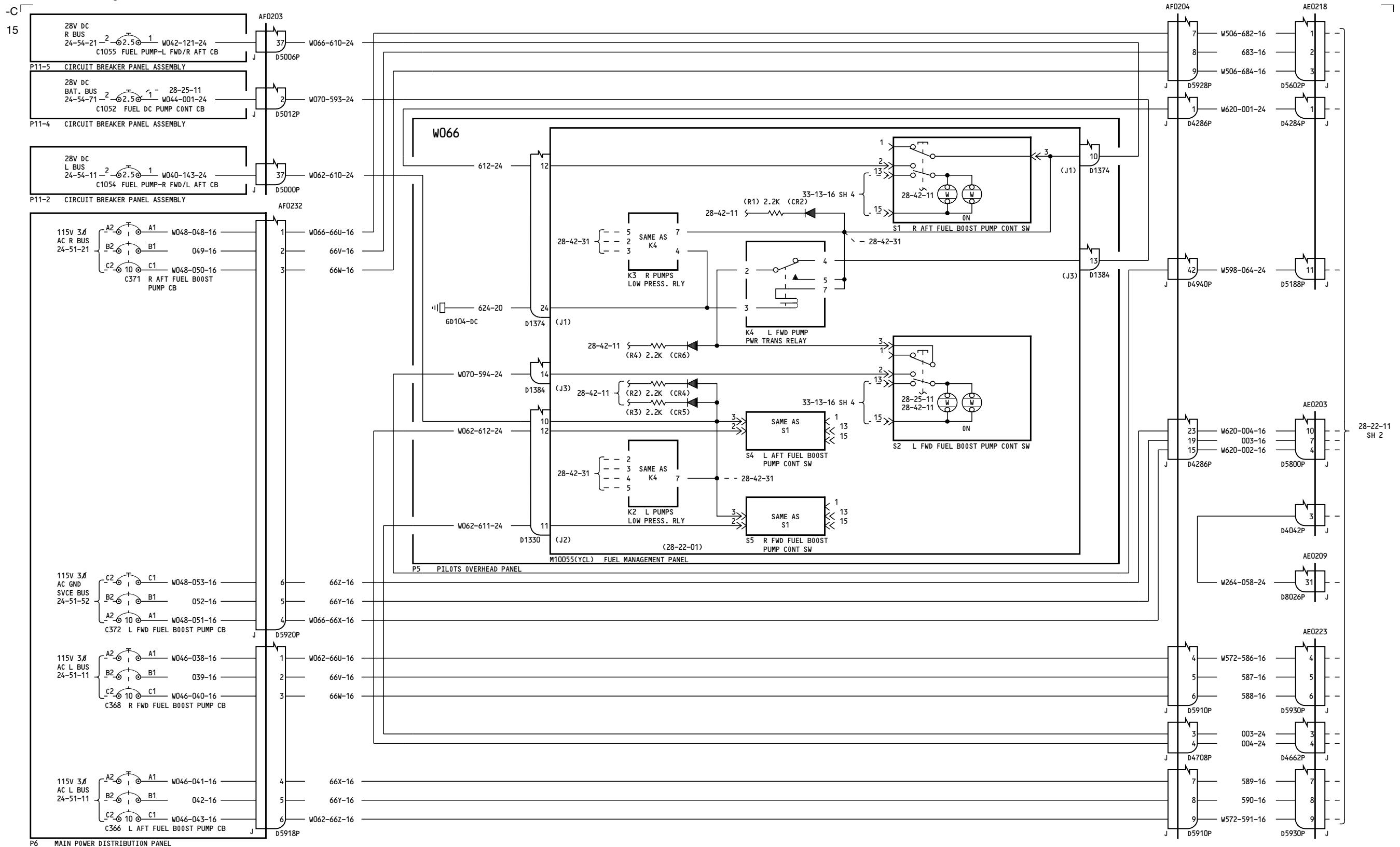

050-099, 150-156, 162-166, 275-276

**FUEL BOOST PUMPS-  
MAIN TANKS**

D280T132

**28-22-11**

Page 1  
Sheet 1  
Jan 21/2005

**28-22-11**

Page 1  
Sheet 1  
Jan 21/2005

-C  
15

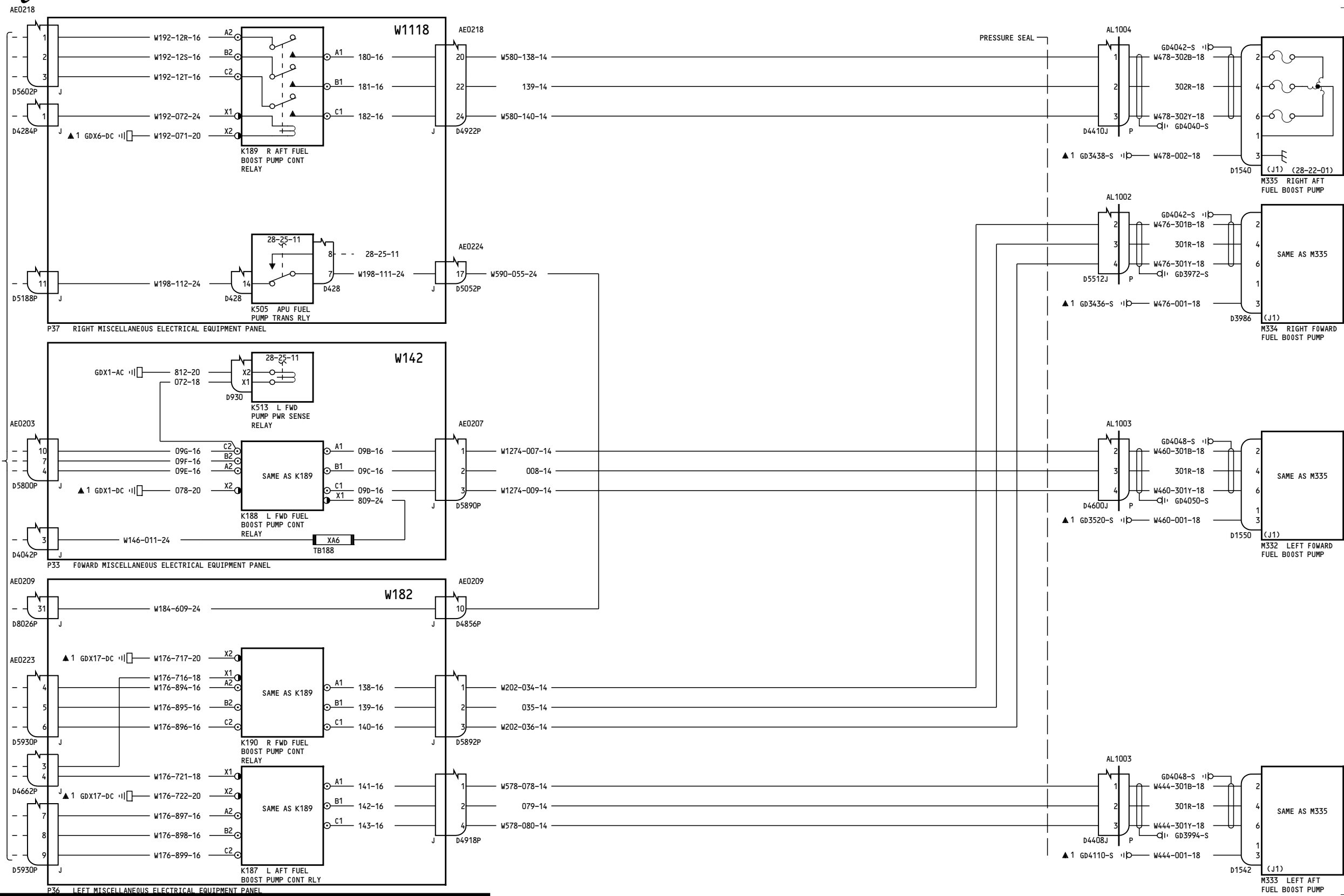

050-099, 150-156, 162-166, 275-276

FUEL BOOST PUMPS-  
MAIN TANKS

D280T132

28-22-11

Page 1  
Sheet 2  
Jan 21/2005

28-22-11

Page 1  
Sheet 2  
Jan 21/2005

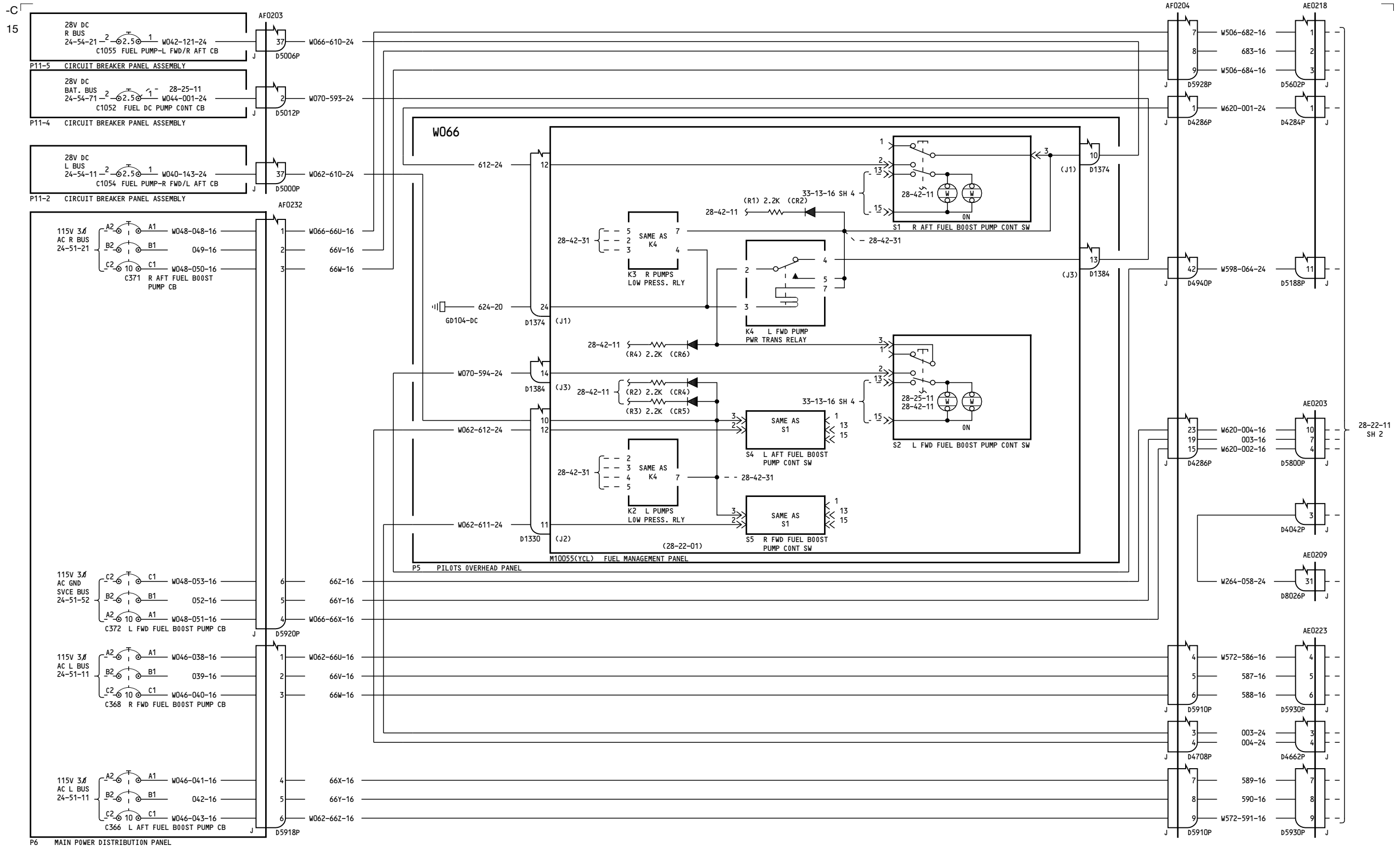

050-156, 162-166, 275-276

FUEL BOOST PUMPS-  
MAIN TANKS

28-22-11

Page 1.1  
Sheet 1  
Jan 21/2005

D280T132

28-22-11

Page 1.1  
Sheet 1  
Jan 21/2005

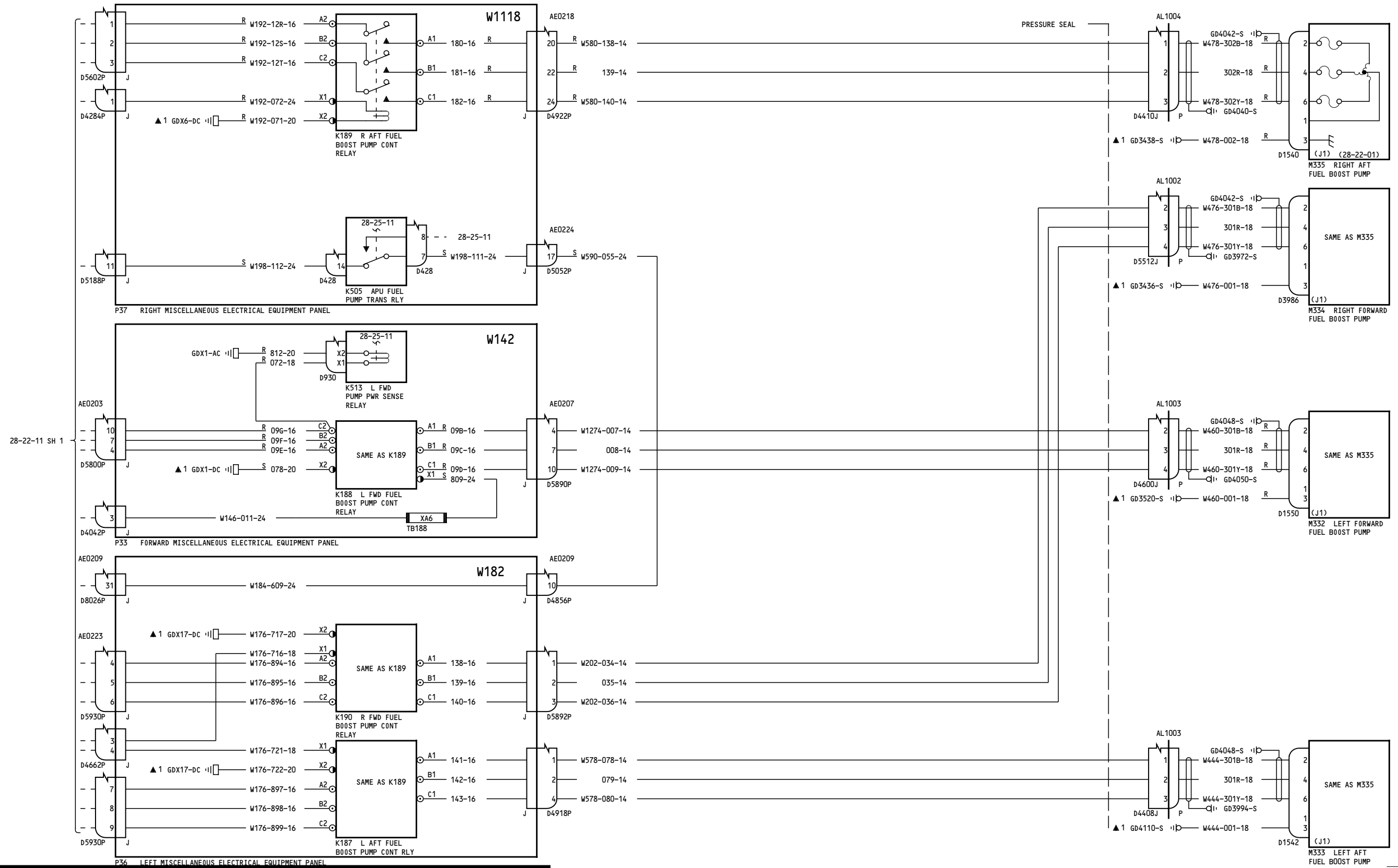

050-156, 162-166, 275-276

**FUEL BOOST PUMPS-  
MAIN TANKS**

**28-22-11**

Page 1.1  
Sheet 2  
Jan 21/2005

D280T132

Incorporates  
28-0034 R02

**28-22-11**

Page 1.1  
Sheet 2  
Jan 21/2005

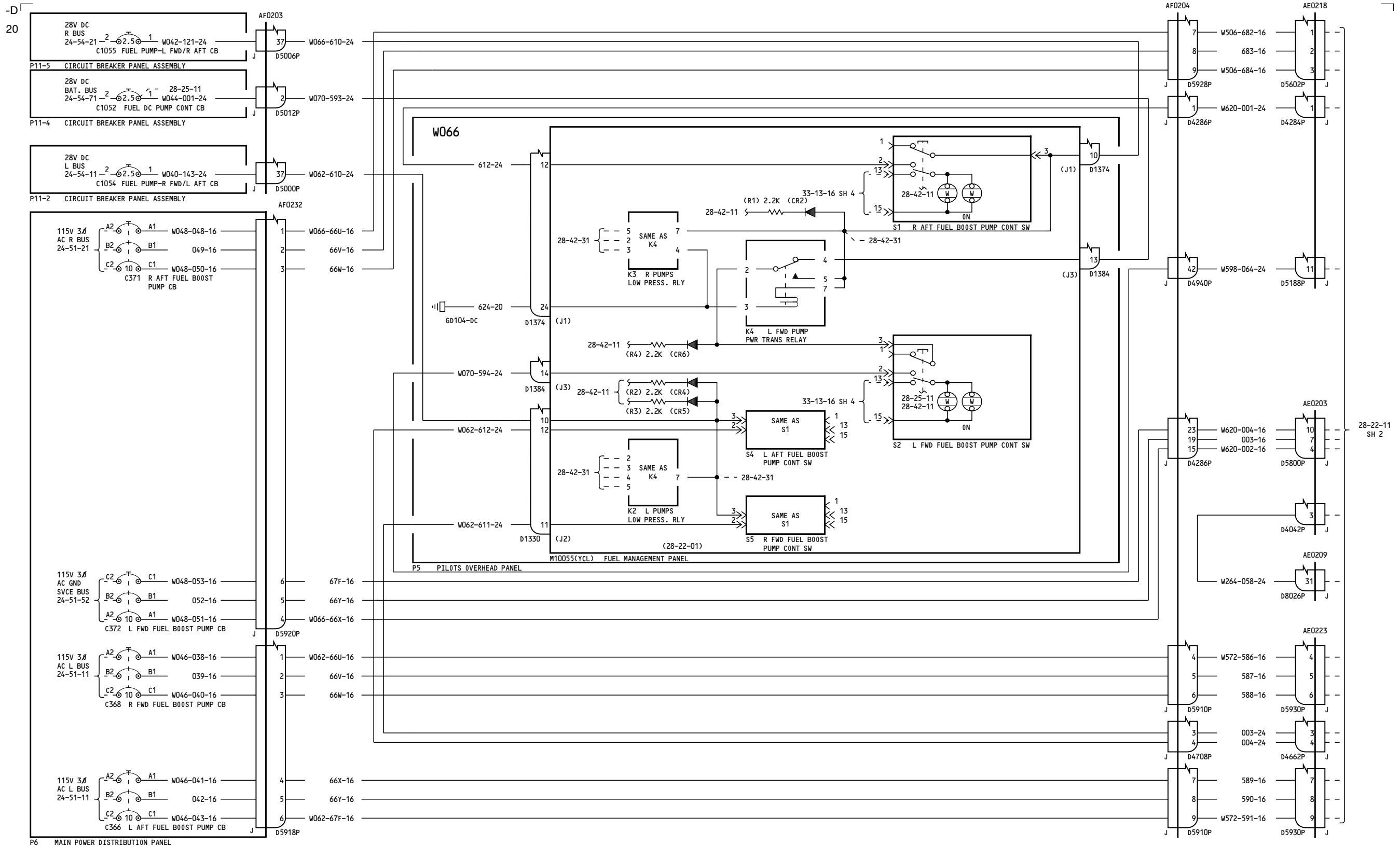

157, 167-199, 277-299

FUEL BOOST PUMPS-  
MAIN TANKS

28-22-11

Page 2  
Sheet 1  
Jan 21/2005

D280T132

28-22-11

Page 2  
Sheet 1  
Jan 21/2005

-B  
20

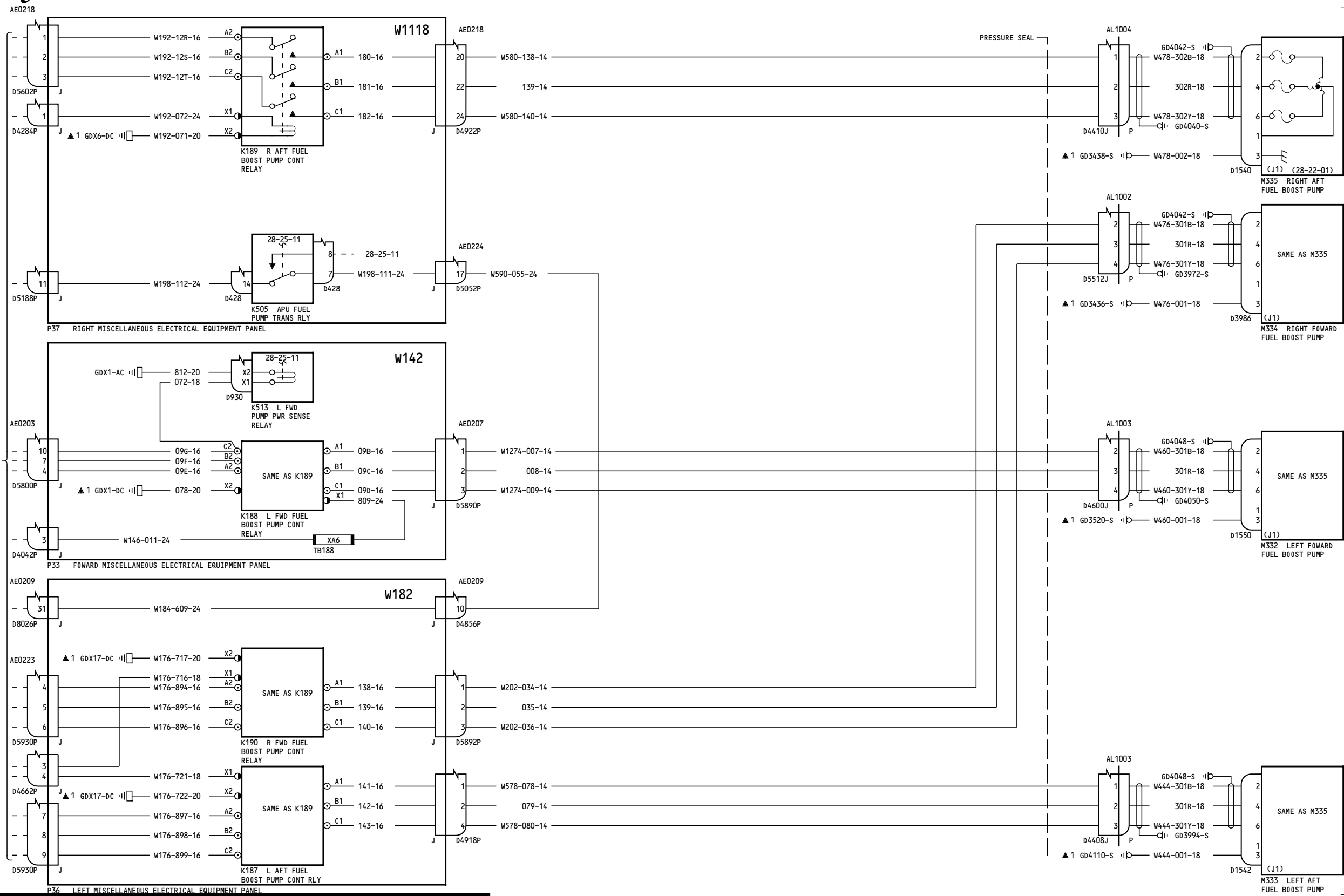

157, 167-199, 277-299

FUEL BOOST PUMPS-  
MAIN TANKS

D280T132

28-22-11

Page 2  
Sheet 2  
Jan 21/2005

28-22-11

Page 2  
Sheet 2  
Jan 21/2005



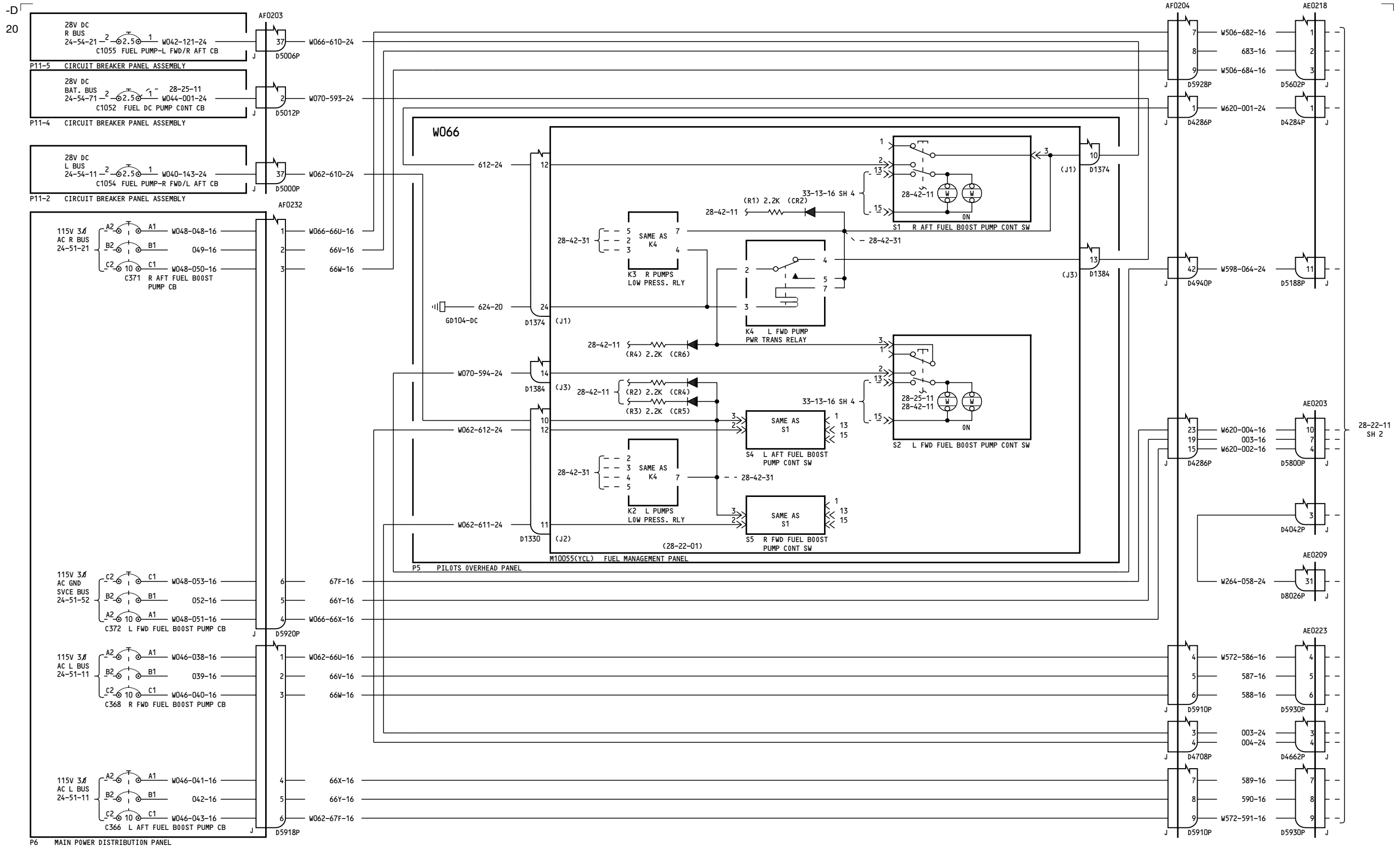

157, 167, 277-280

FUEL BOOST PUMPS-MAIN TANKS

28-22-11

Page 2.1  
Sheet 1  
Jan 21/2005

D280T132

28-22-11

Page 2.1  
Sheet 1  
Jan 21/2005

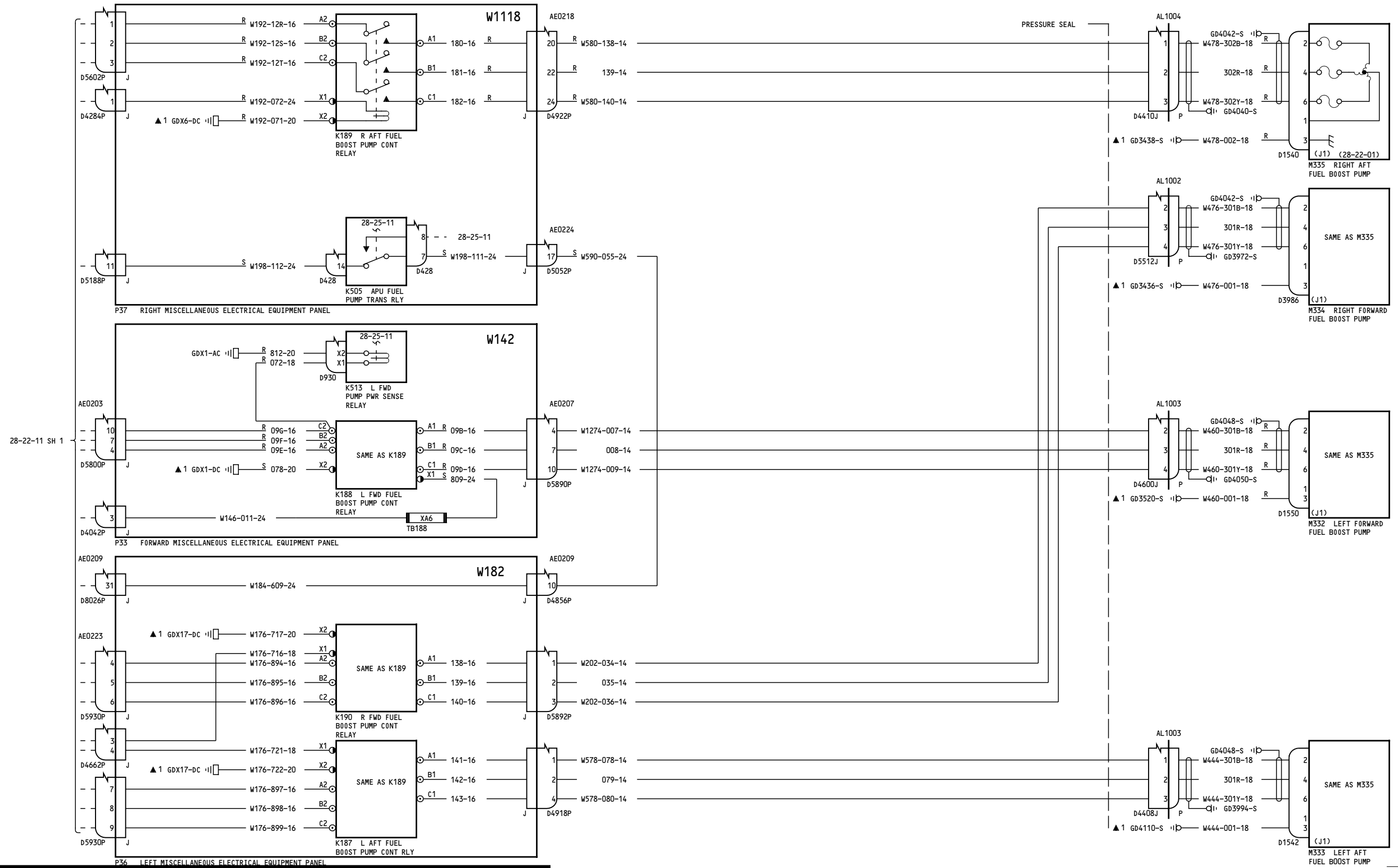

157, 167, 277-280

**FUEL BOOST PUMPS-  
MAIN TANKS**

D280T132

**28-22-11**

Page 2.1  
Sheet 2  
Jan 21/2005

Incorporates  
28-0034 R02

**28-22-11**

Page 2.1  
Sheet 2  
Jan 21/2005

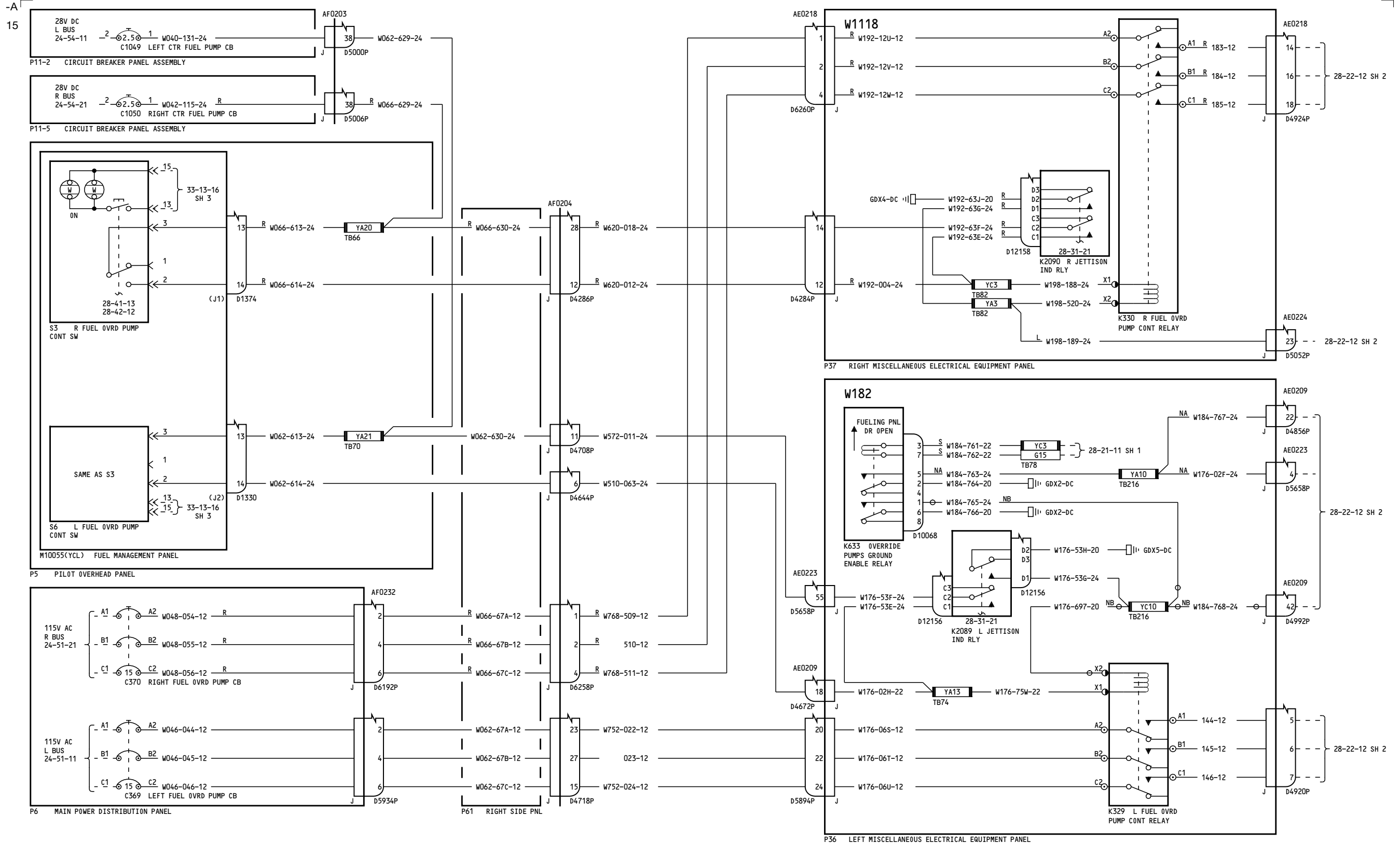

050-099, 155-199, 276-299

**FUEL OVERRIDE BOOST PUMPS-AUXILIARY TANKS**

D280T132

**28-22-12**

Page 1  
Sheet 1  
Jan 21/2005

**28-22-12**

Page 1  
Sheet 1  
Jan 21/2005

2

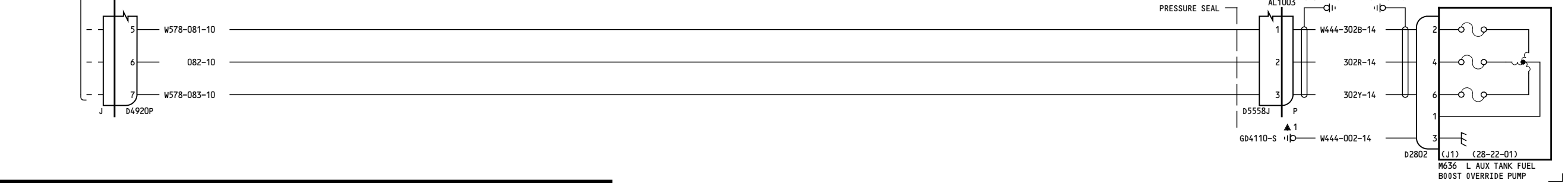
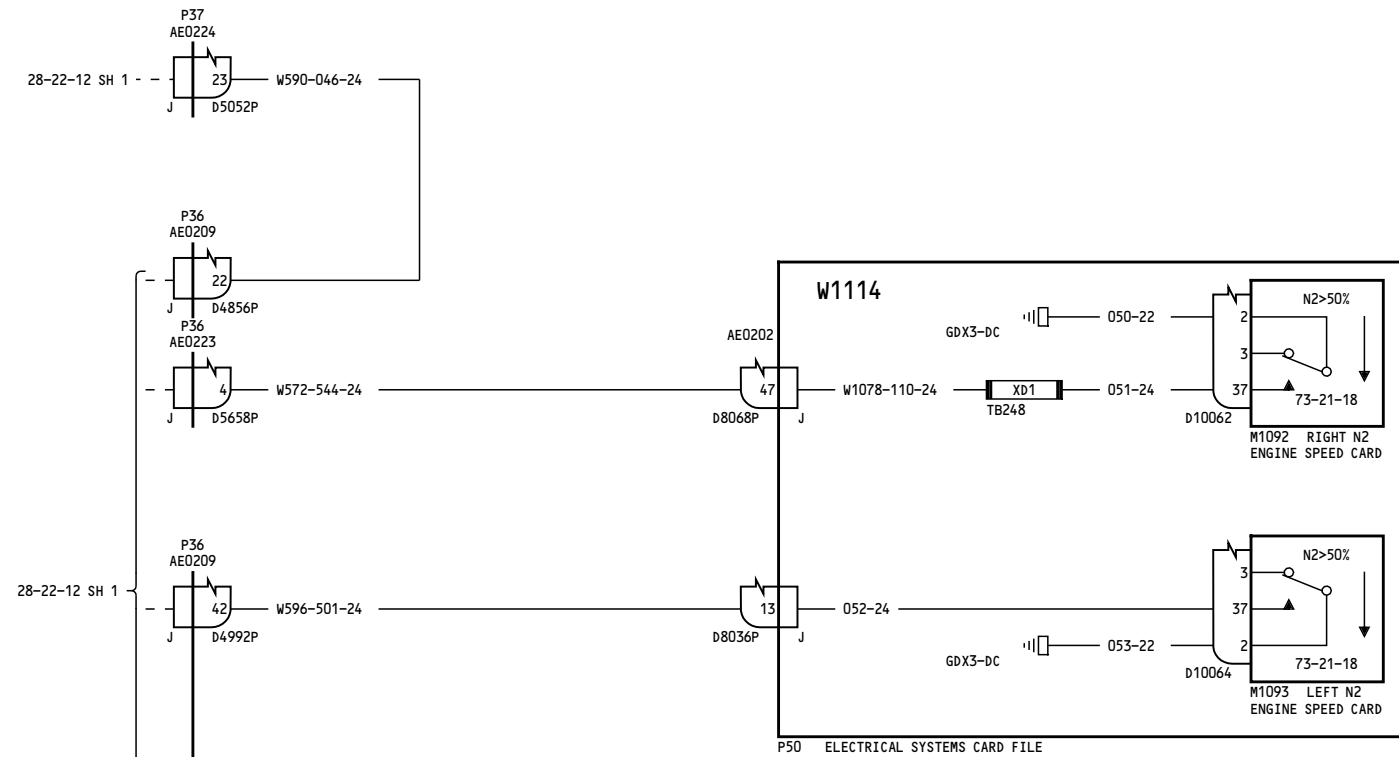
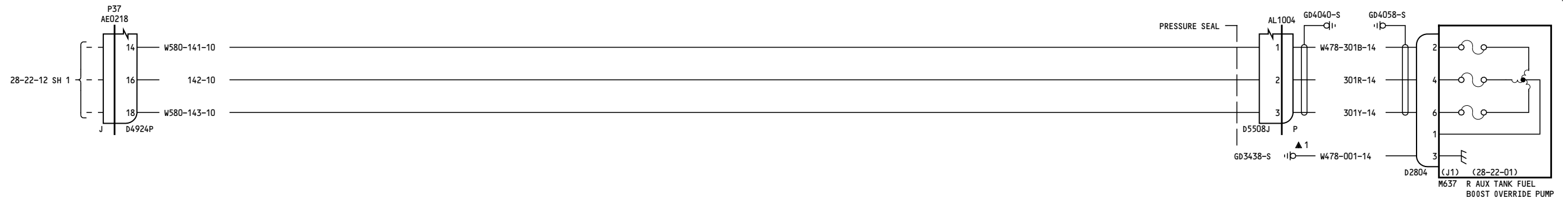

050-099, 155-199, 276-299

**FUEL OVERRIDE BOOST  
PUMPS-  
AUXILIARY TANKS**

D280T132

**28-22-12**

Page 1  
Sheet 2  
Jan 21/2005

**28-22-12**

Page 1  
Sheet 2  
Jan 21/2005

135

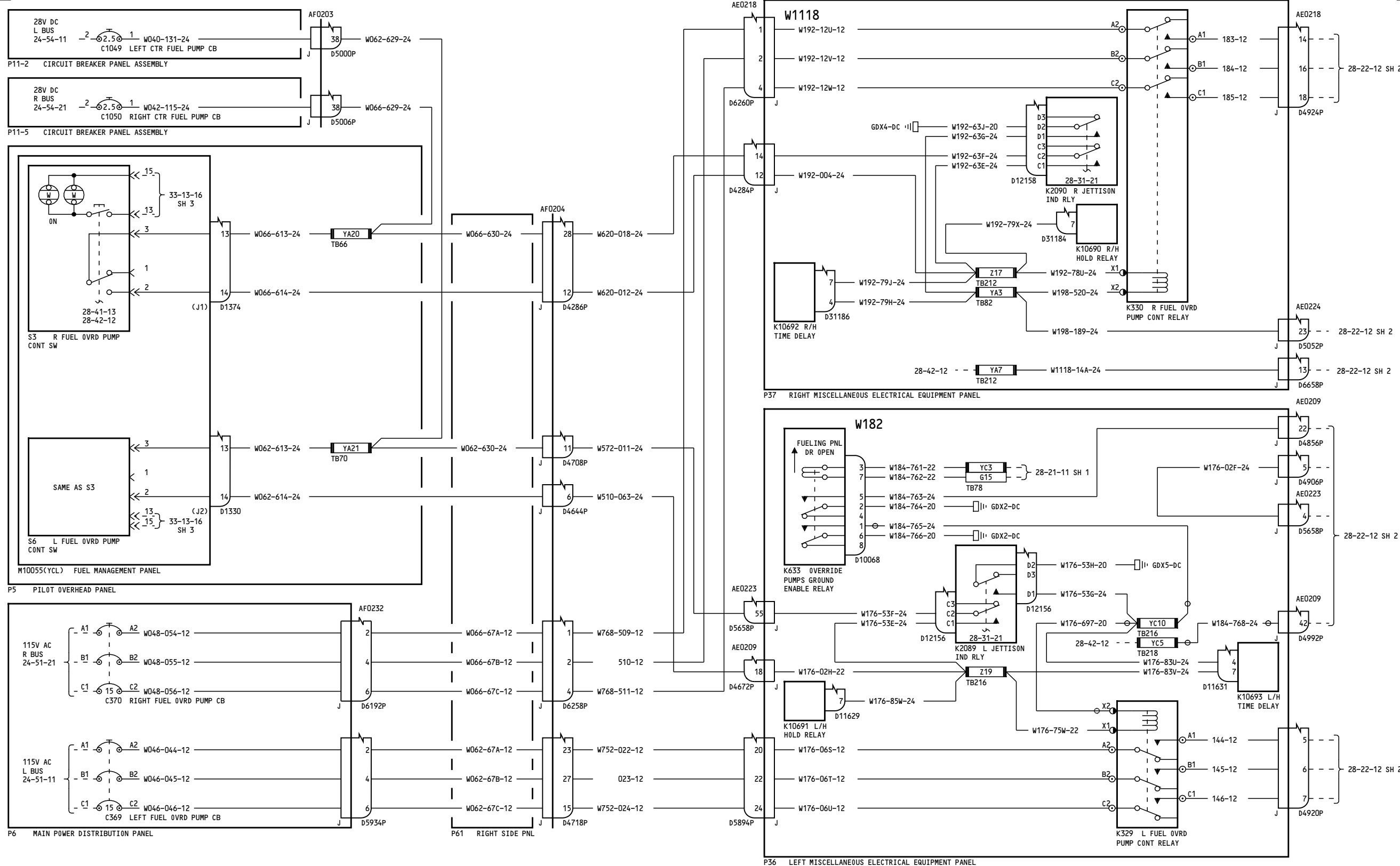

050-051, 276-278

FUEL OVERRIDE BOOST PUMPS-AUXILIARY TANKS

28-22-12

Page 1.1 Sheet 1 Aug 05/2009

D280T132

Incorporates 28A0083 R01

28-22-12

Page 1.1 Sheet 1 Aug 05/2009

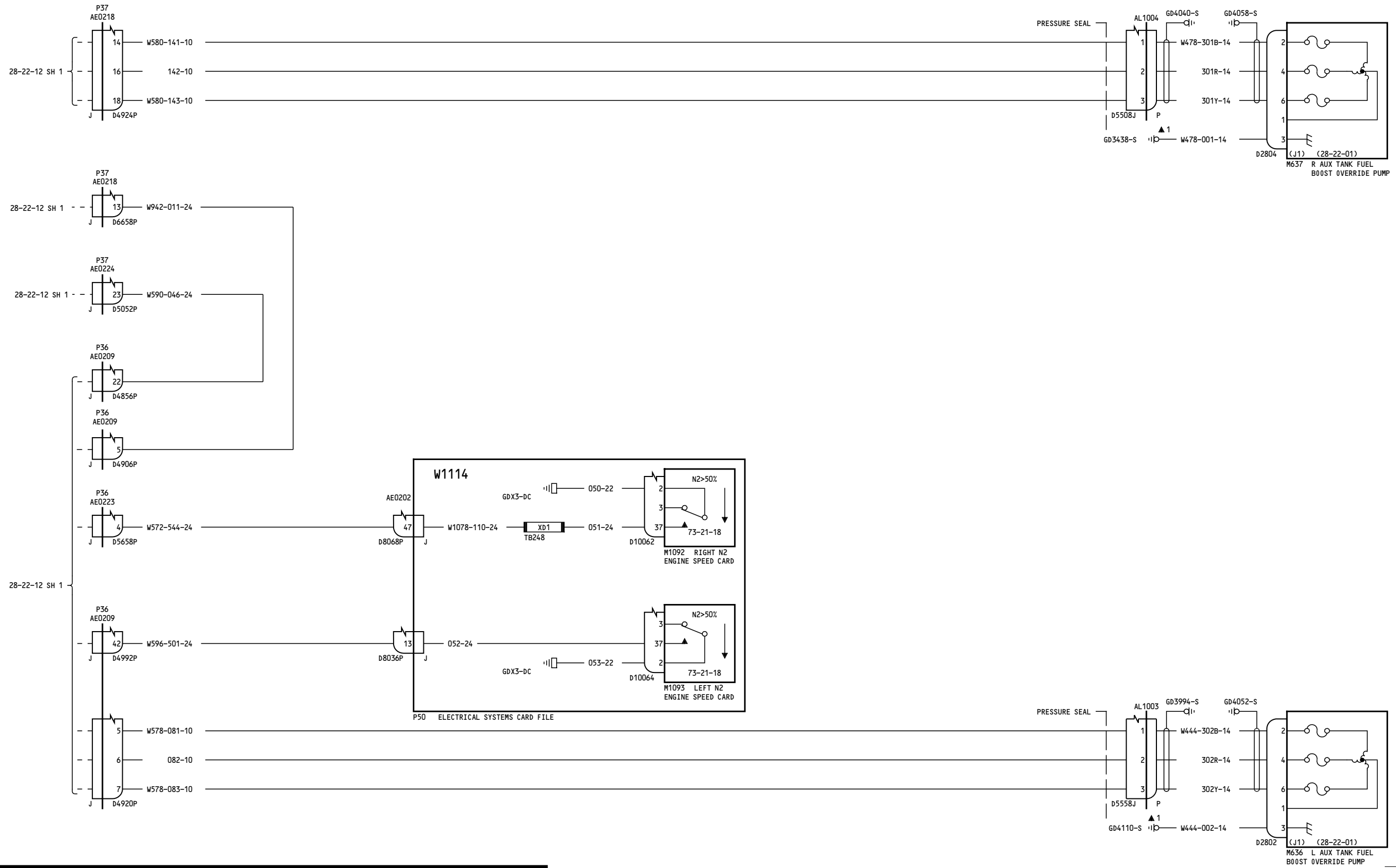

050-051, 276-278

**FUEL OVERRIDE BOOST PUMPS-AUXILIARY TANKS**

D280T132

**28-22-12**

Page 1.1  
Sheet 2  
Feb 06/2009

Incorporates  
28A0083 R01

**28-22-12**

Page 1.1  
Sheet 2  
Feb 06/2009

133

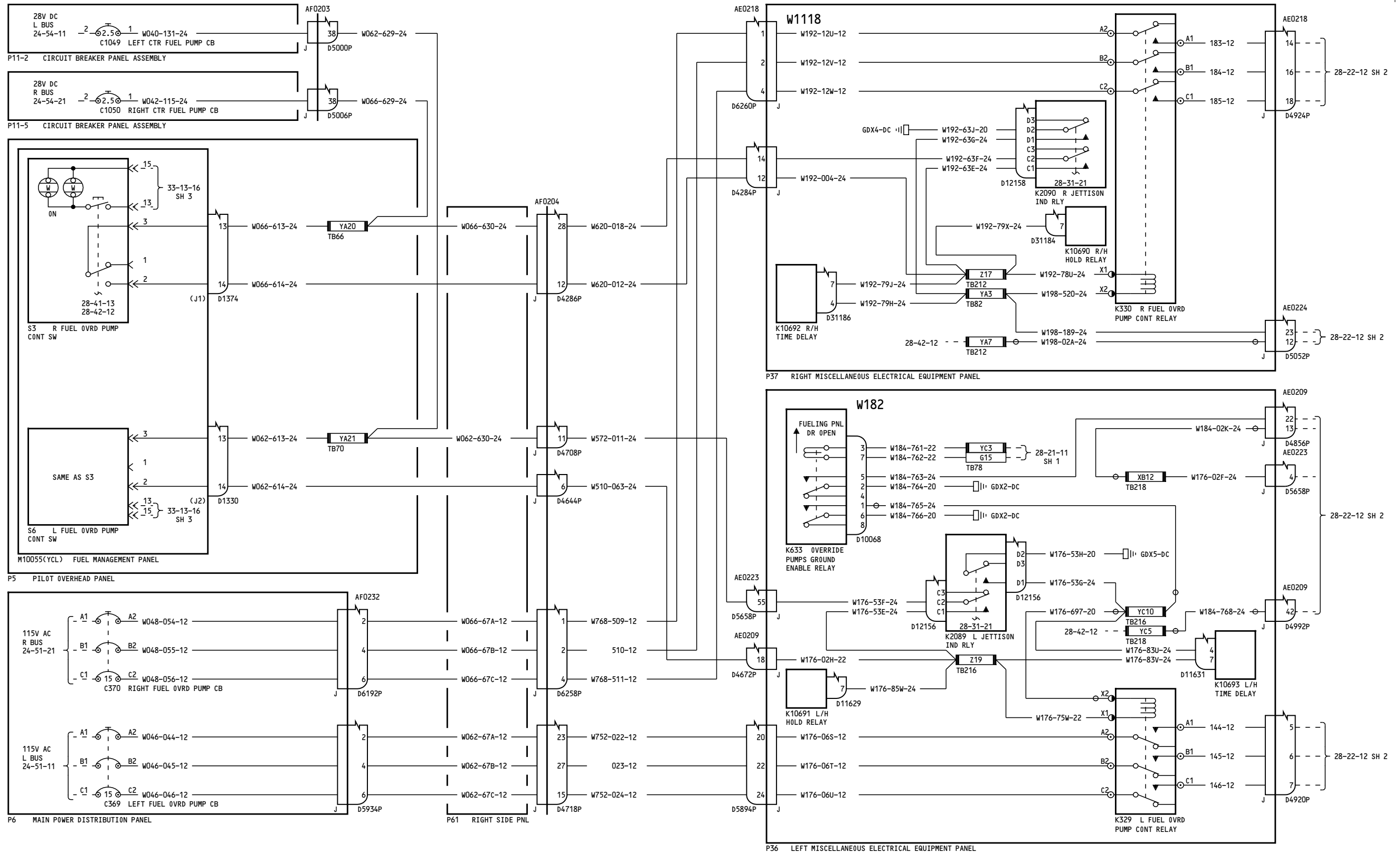

155-157

FUEL OVERRIDE BOOST PUMPS-AUXILIARY TANKS

28-22-12

Page 1.2 Sheet 1 Aug 05/2009

D280T132

Incorporates 28A0083 R01

28-22-12

Page 1.2 Sheet 1 Aug 05/2009

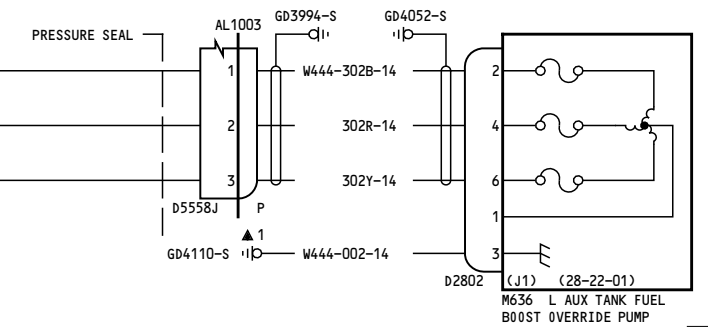
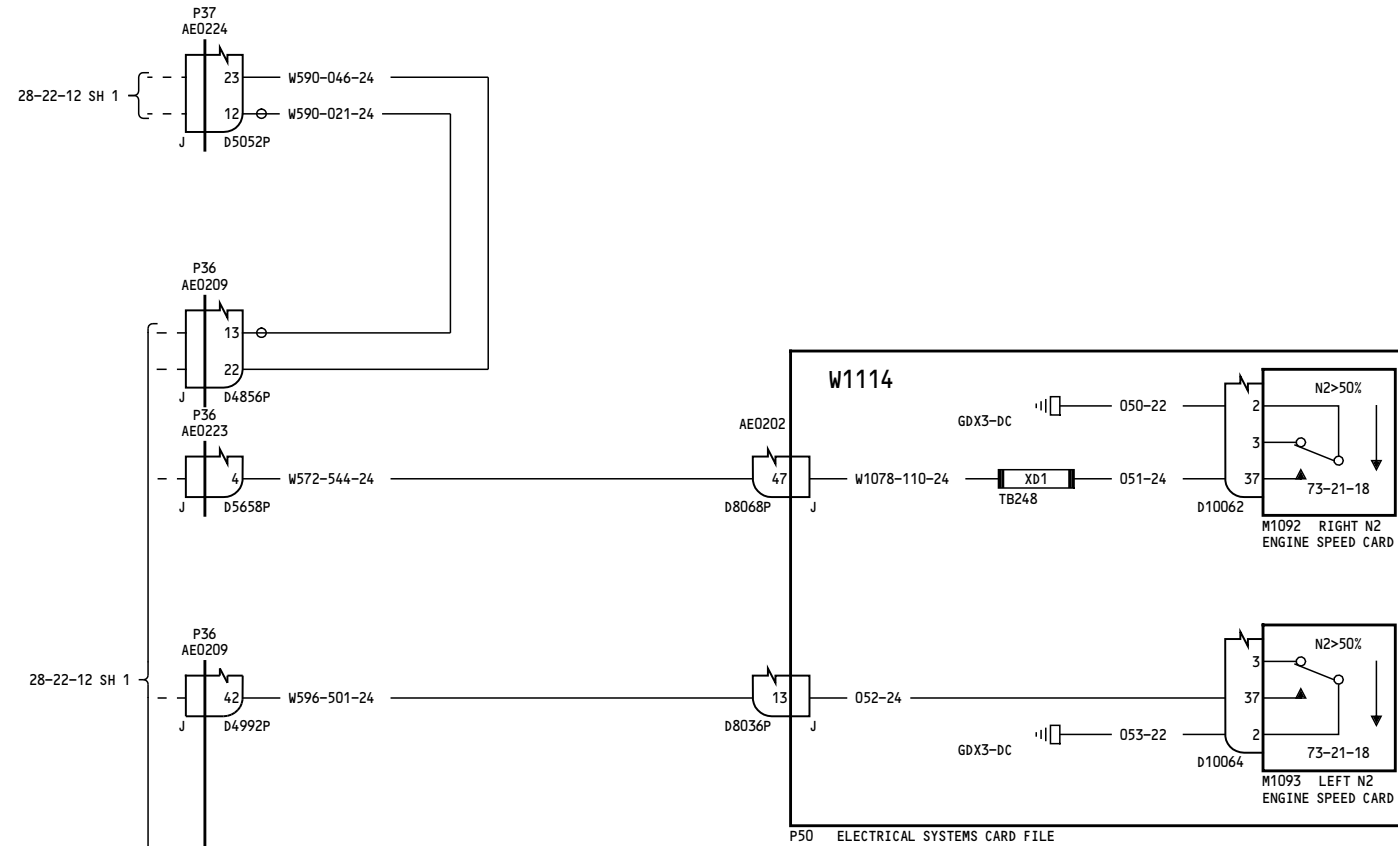
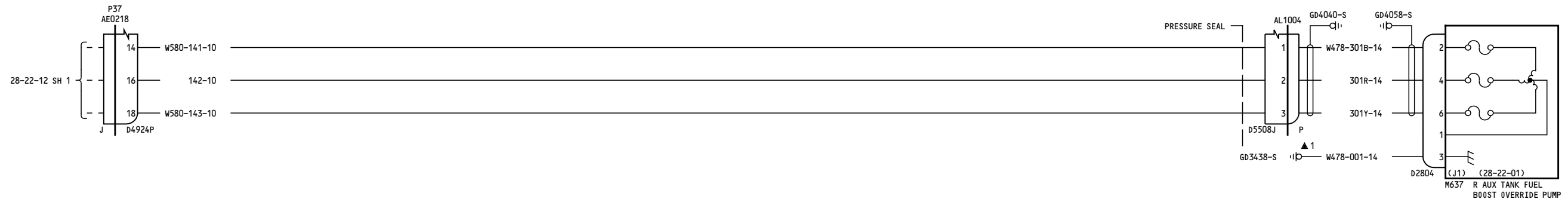

155-157

**FUEL OVERRIDE BOOST  
PUMPS-  
AUXILIARY TANKS**

D280T132

**28-22-12**

Page 1.2  
Sheet 2  
Feb 06/2009

Incorporates  
28A0083 R01

**28-22-12**

Page 1.2  
Sheet 2  
Feb 06/2009



134

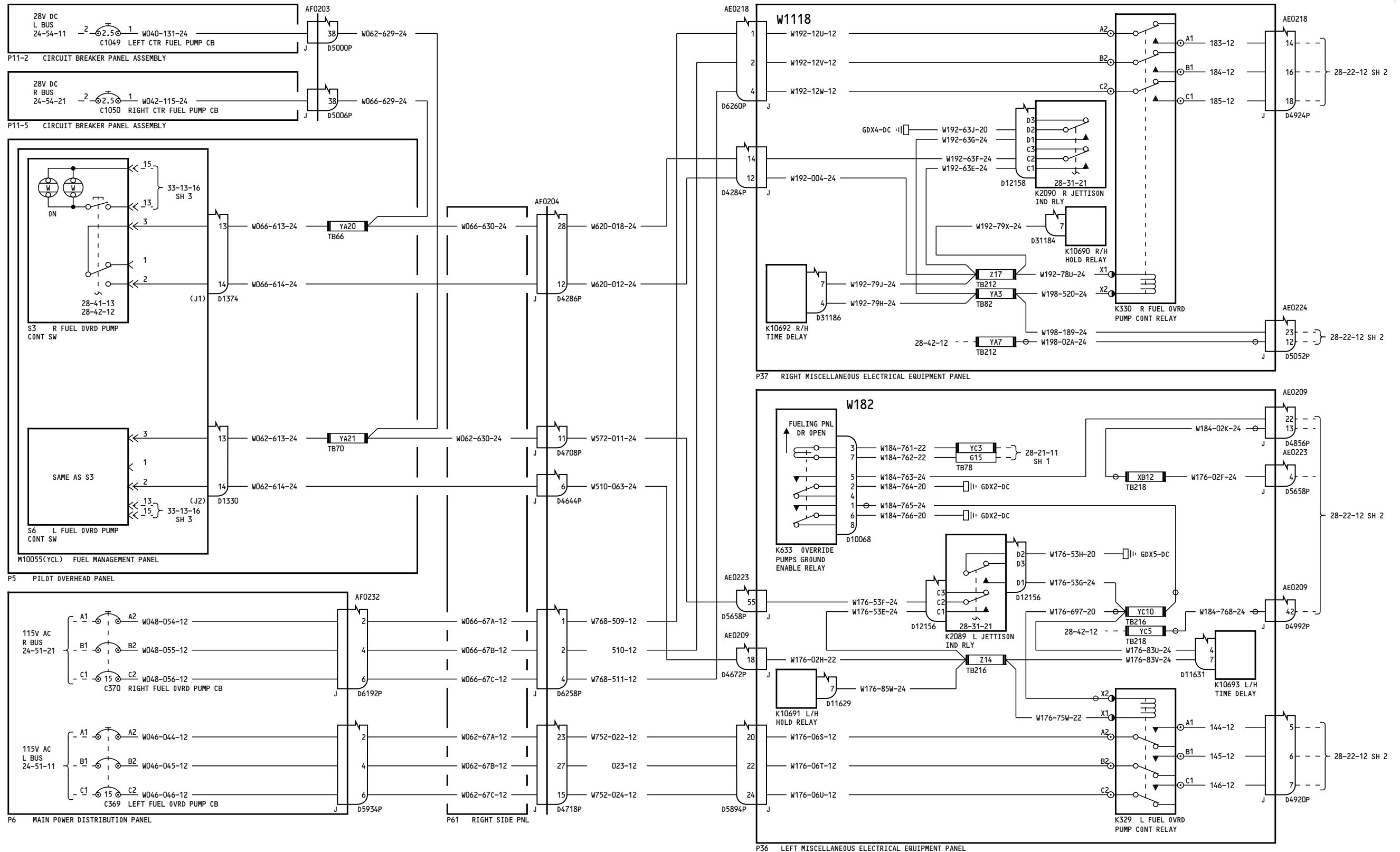

162-167

FUEL OVERRIDE BOOST PUMPS-AUXILIARY TANKS

D280T132

28-22-12

Page 1.3 Sheet 1 Aug 05/2009

Incorporates 28A0083 R01

28-22-12

Page 1.3 Sheet 1 Aug 05/2009

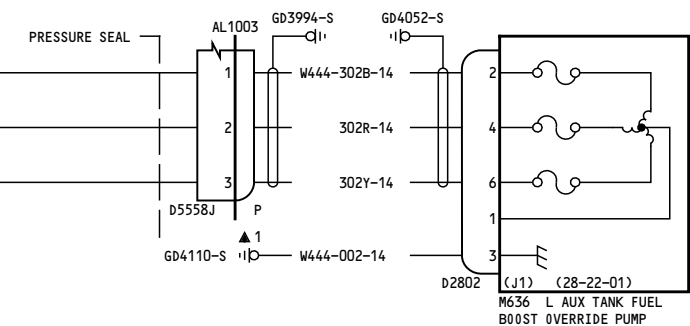
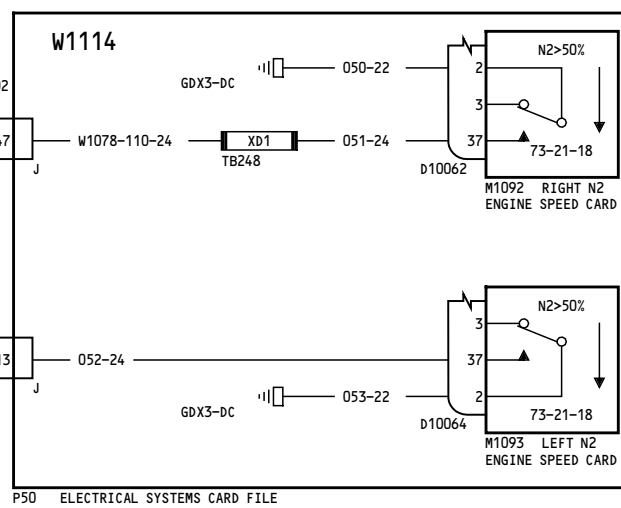
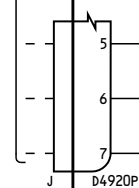
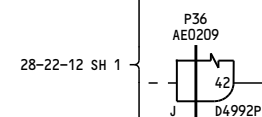
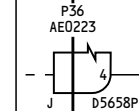
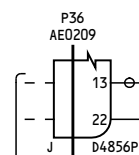
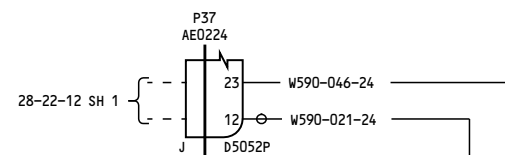
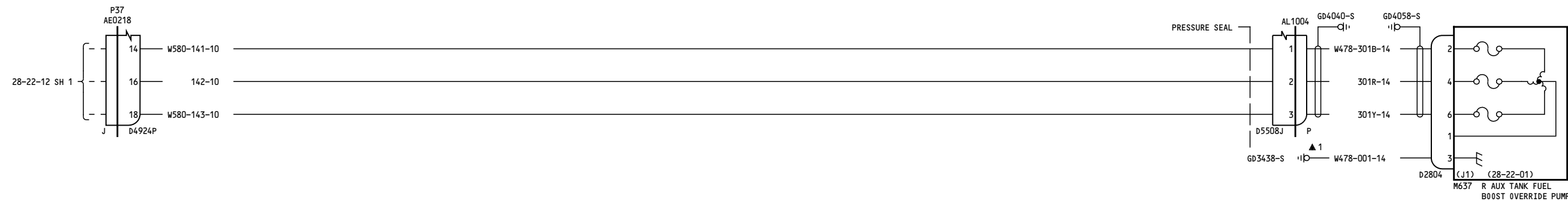

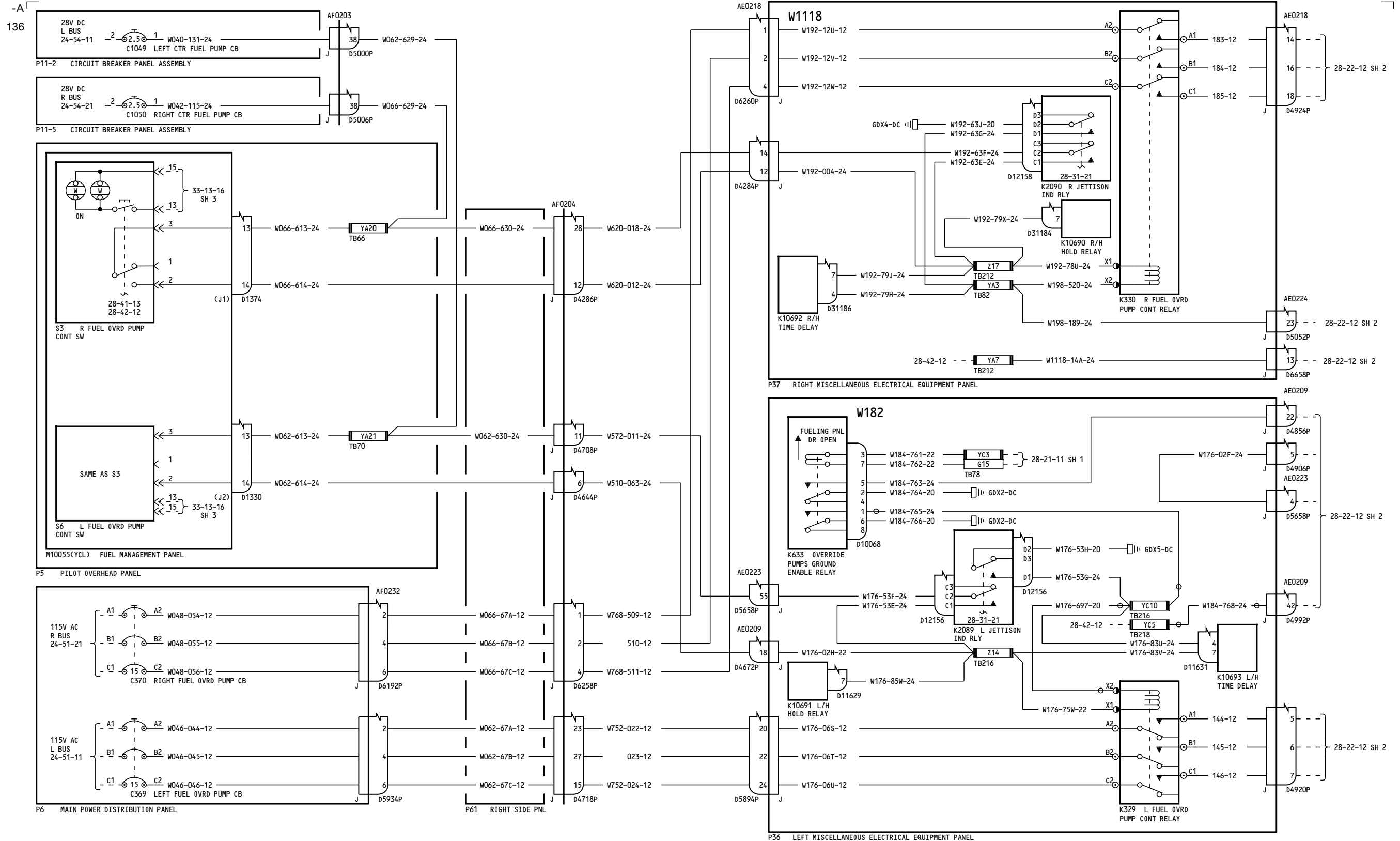

280

FUEL OVERRIDE BOOST PUMPS-AUXILIARY TANKS

28-22-12

Page 1.4 Sheet 1 Aug 05/2009

D280T132

Incorporates 28A0083 R01

28-22-12

Page 1.4 Sheet 1 Aug 05/2009

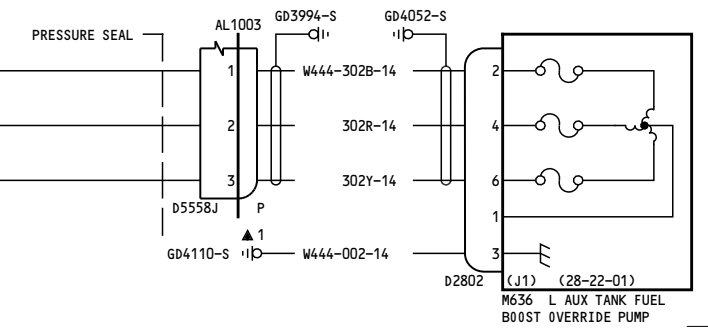
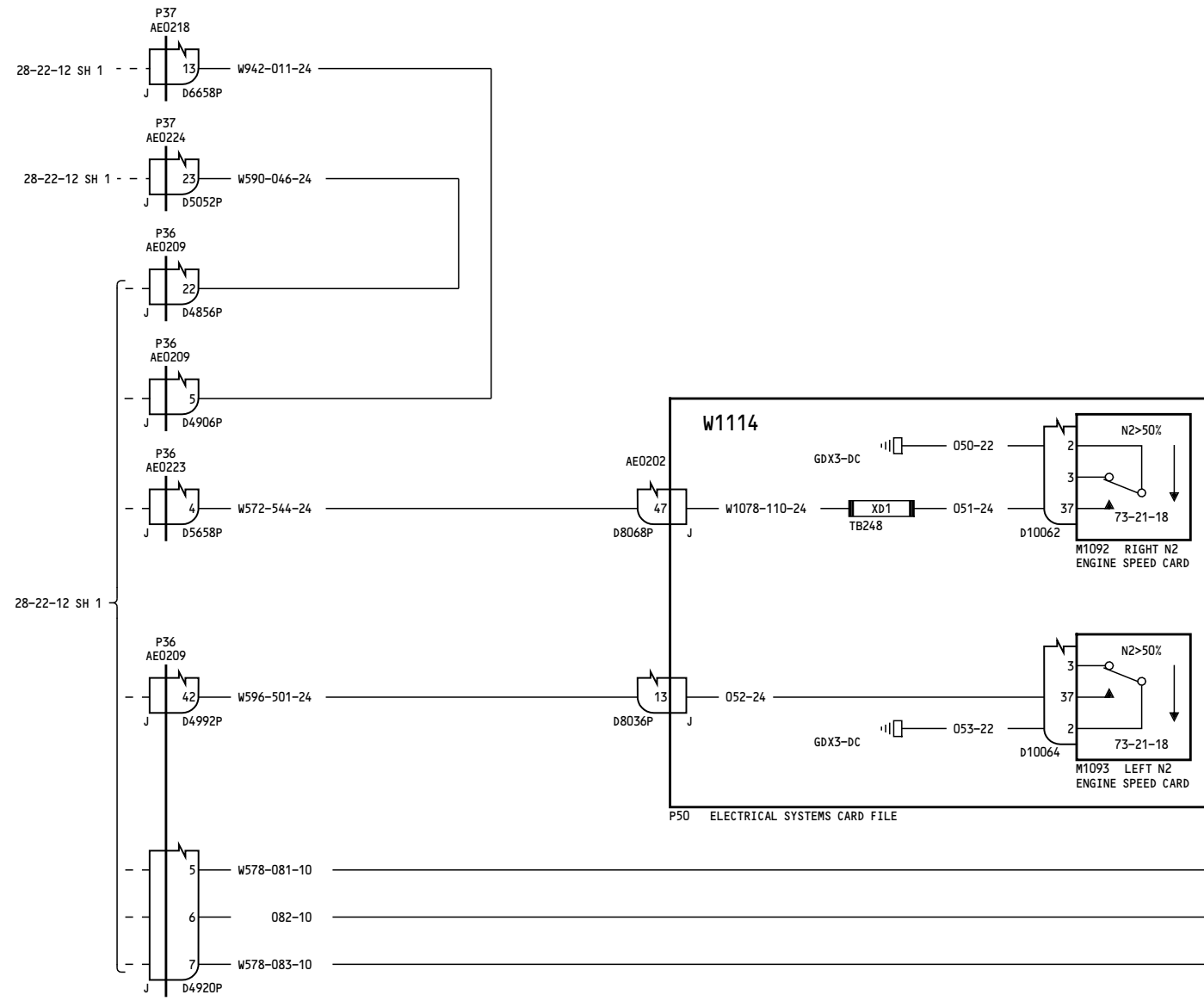
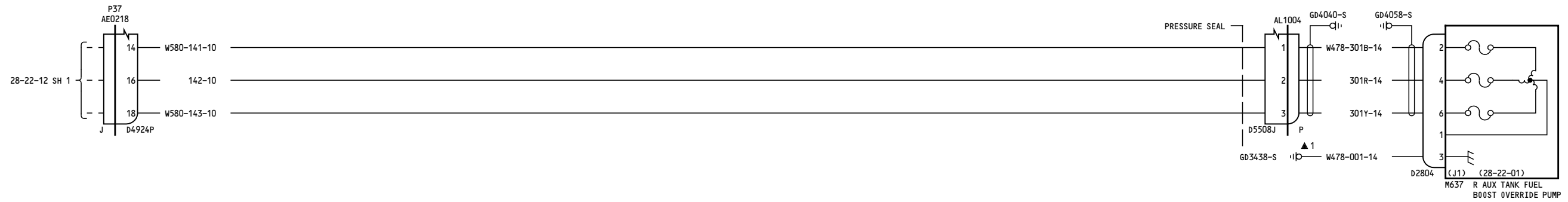

280	<p align="center"><b>FUEL OVERRIDE BOOST PUMPS-AUXILIARY TANKS</b></p> <p align="center">D280T132</p>
-----	---

28-22-12

Page 1.4  
Sheet 2  
Feb 06/2009

Incorporates  
28A0083 R01

28-22-12

Page 1.4  
Sheet 2  
Feb 06/2009

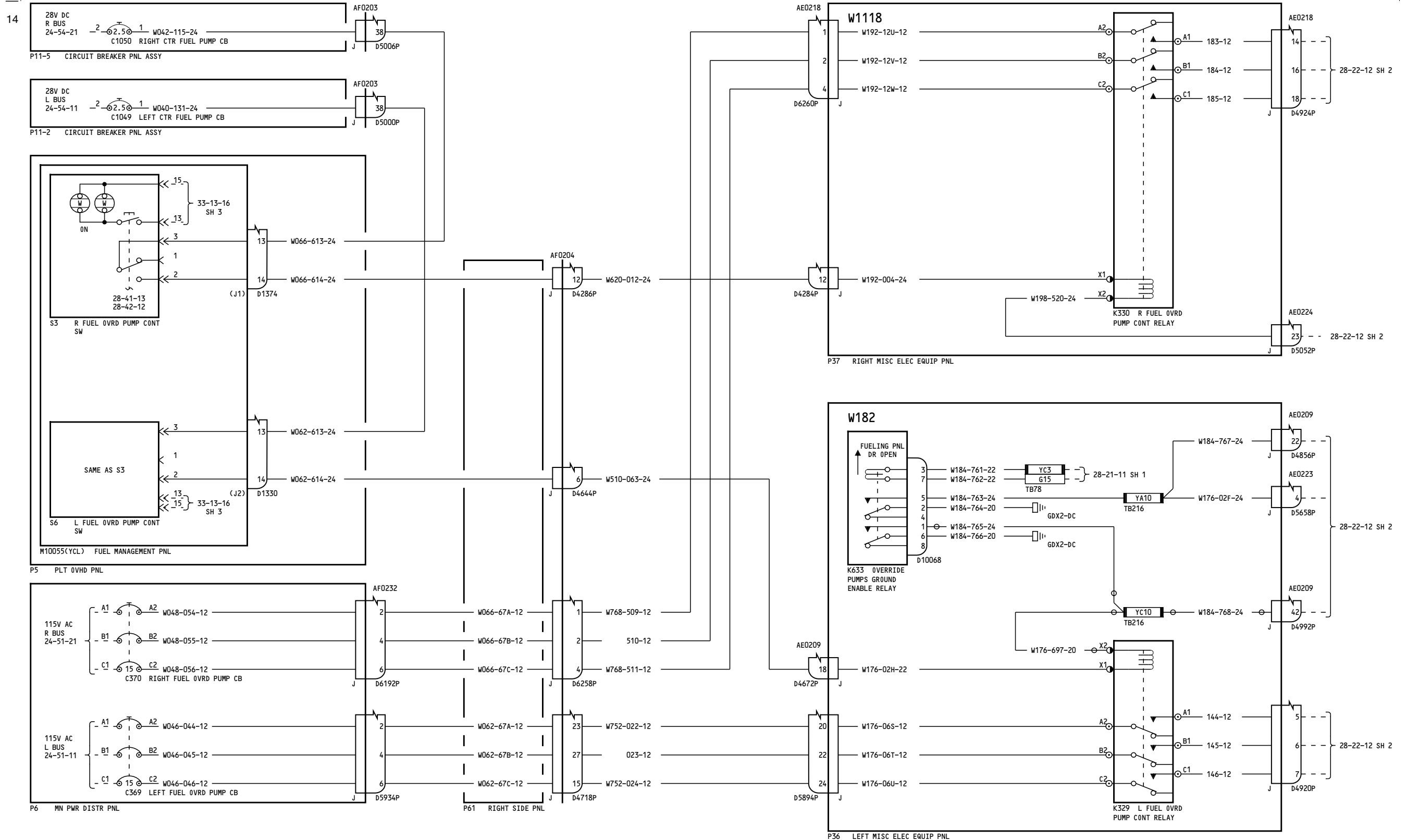

150-154, 275

FUEL OVERRIDE BOOST PUMPS-AUXILIARY TANKS

28-22-12

Page 2  
Sheet 1  
Jan 21/2005

D280T132

28-22-12

Page 2  
Sheet 1  
Jan 21/2005

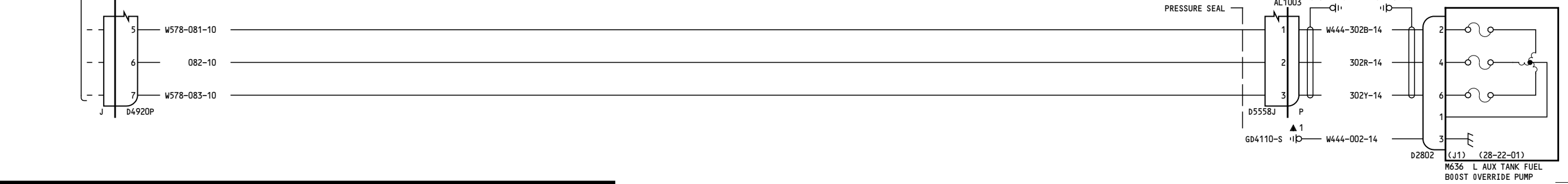
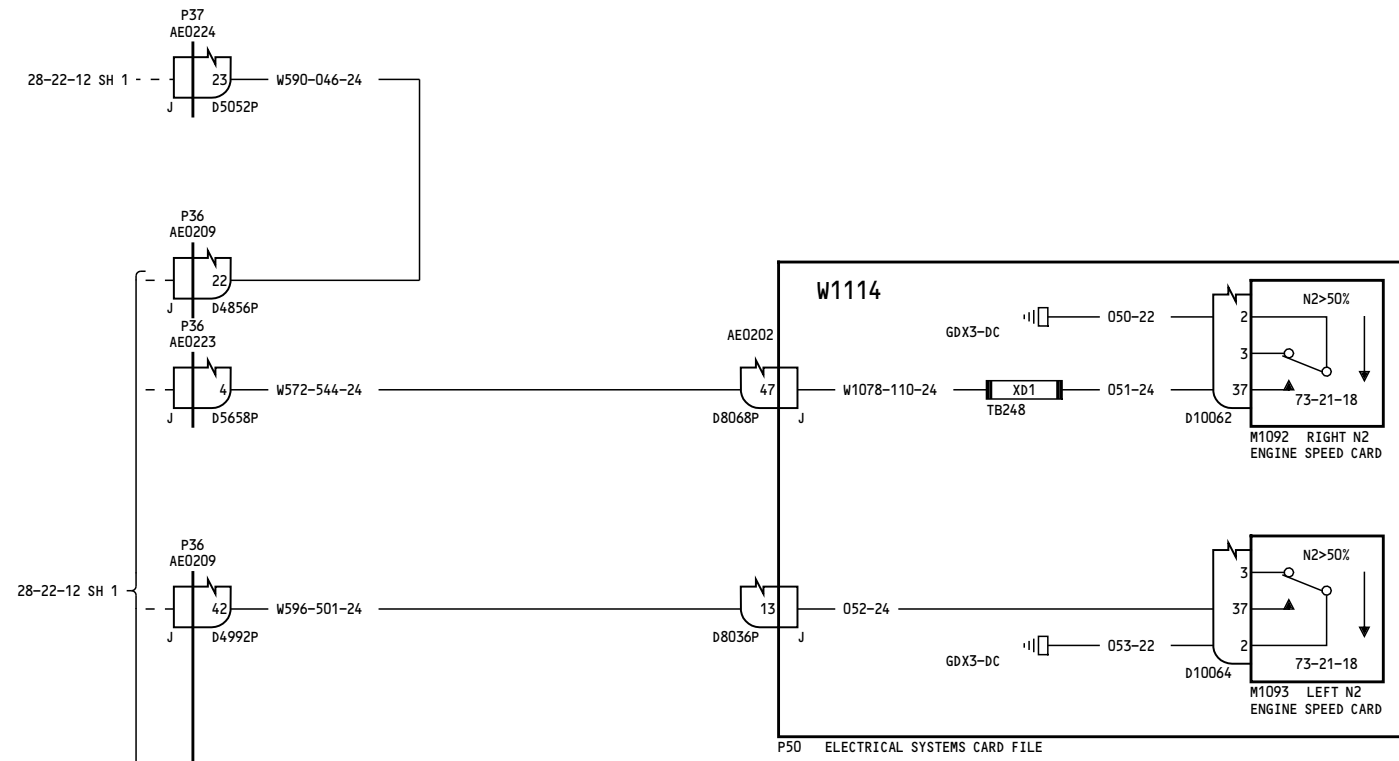
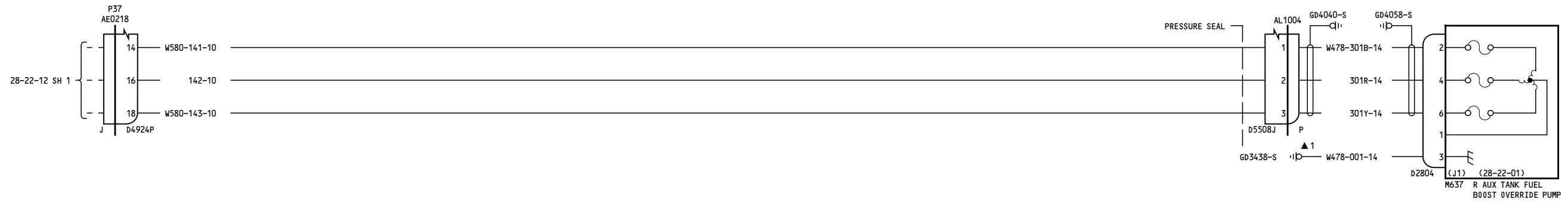

150-154, 275

**FUEL OVERRIDE BOOST  
PUMPS-  
AUXILIARY TANKS**

D280T132

**28-22-12**

Page 2  
Sheet 2  
Jan 21/2005

**28-22-12**

Page 2  
Sheet 2  
Jan 21/2005

131

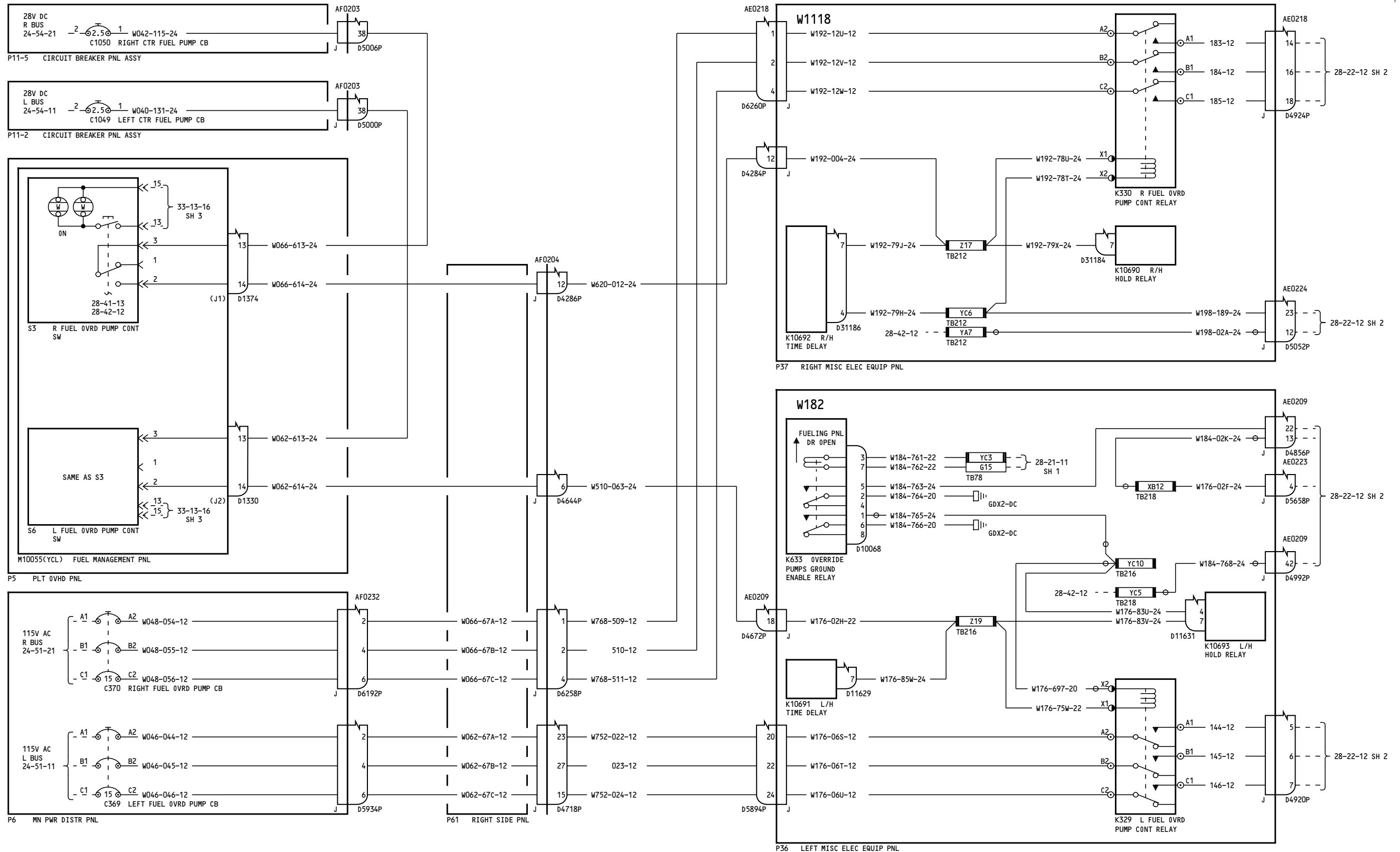

150-154

FUEL OVERRIDE BOOST PUMPS-AUXILIARY TANKS

28-22-12

Page 2.1 Sheet 1 Aug 05/2009

D280T132

Incorporates 28A0083 R01

28-22-12

Page 2.1 Sheet 1 Aug 05/2009

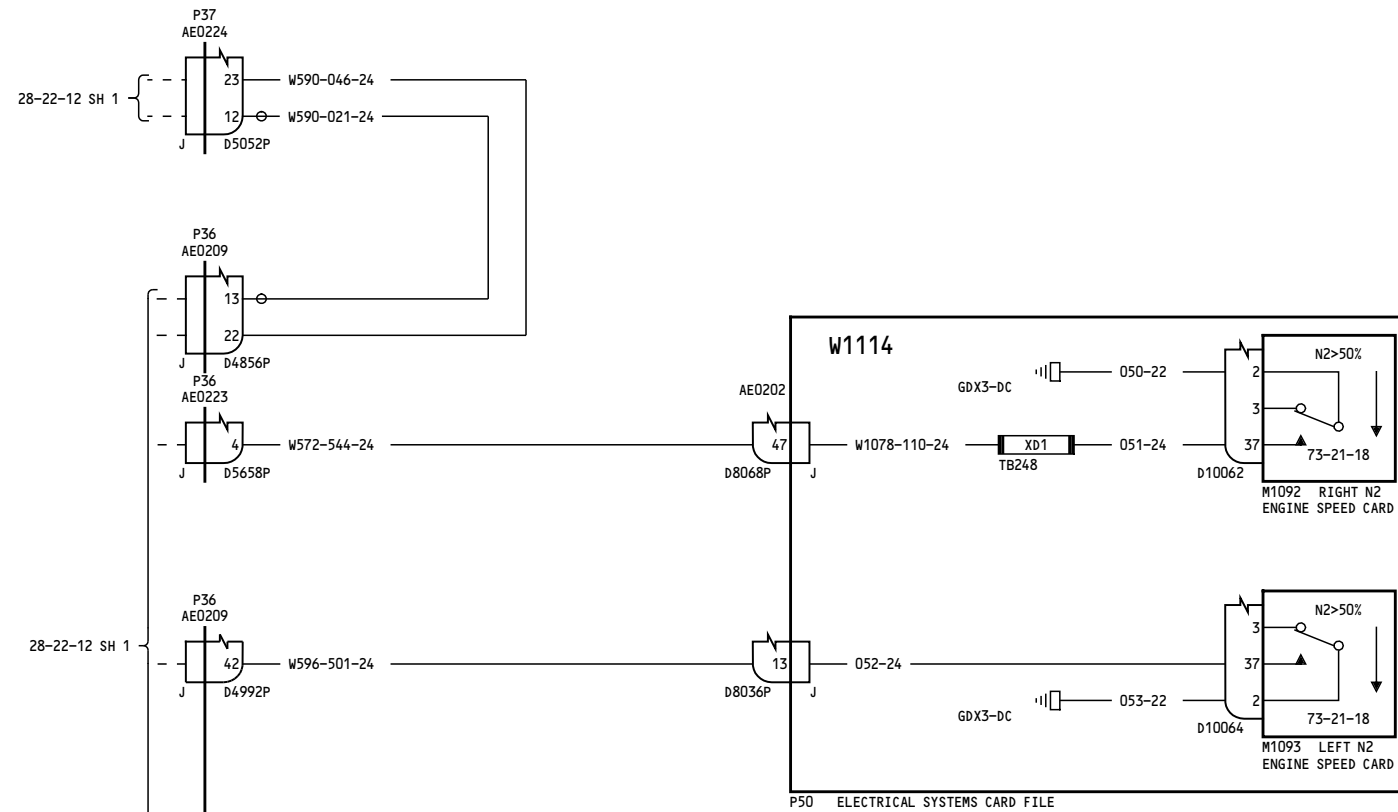
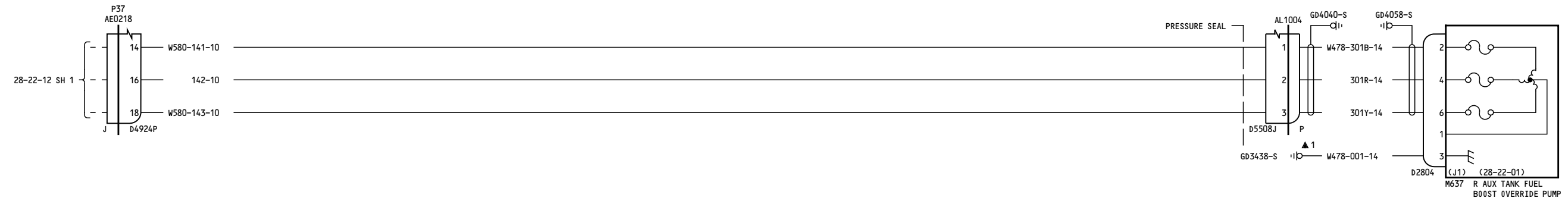

150-154

**FUEL OVERRIDE BOOST  
PUMPS-  
AUXILIARY TANKS**

D280T132

**28-22-12**

Page 2.1  
Sheet 2  
Feb 06/2009

Incorporates  
28A0083 R01

**28-22-12**

Page 2.1  
Sheet 2  
Feb 06/2009



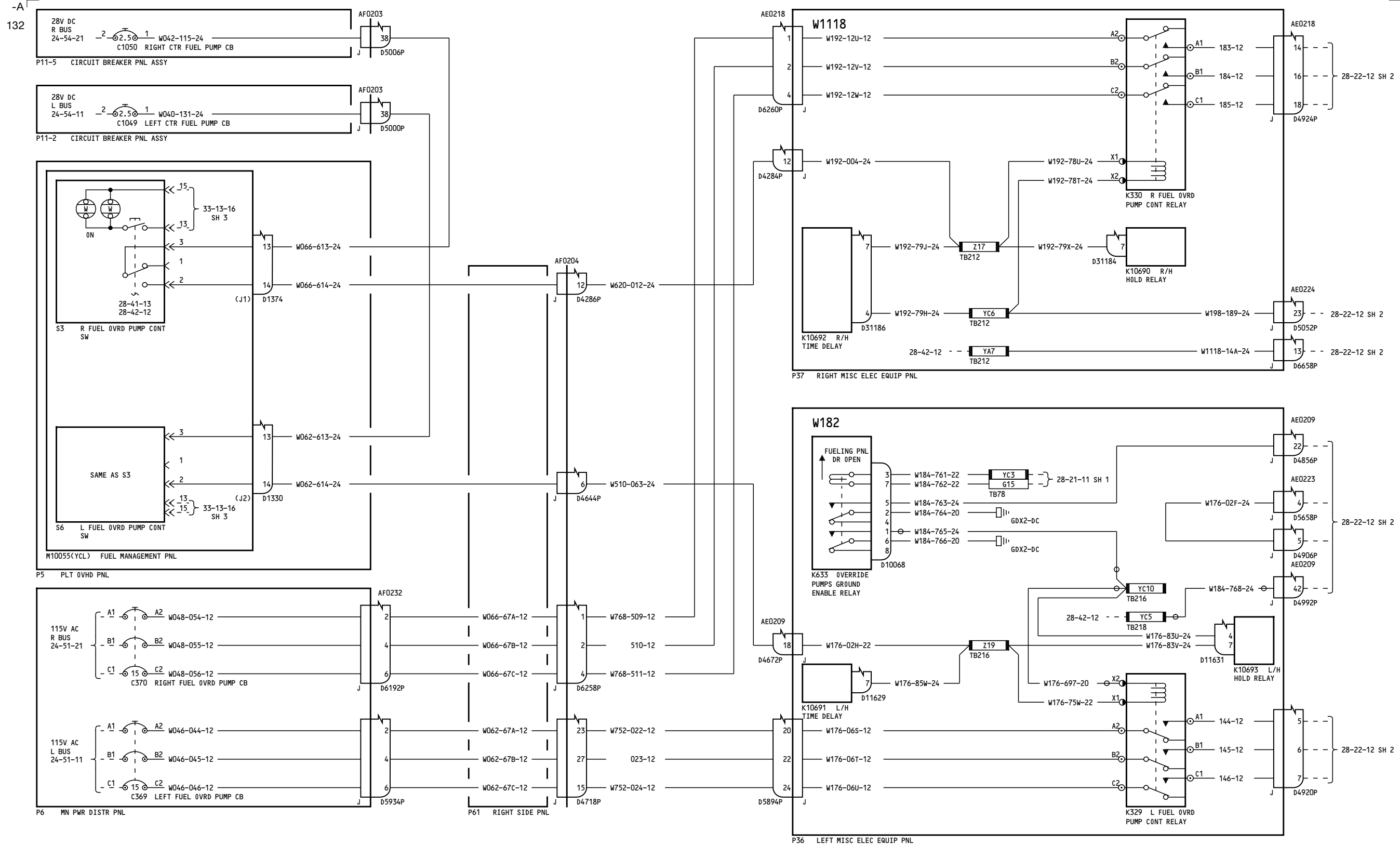

275

FUEL OVERRIDE BOOST PUMPS-AUXILIARY TANKS

28-22-12

Page 2.2 Sheet 1 Aug 05/2009

D280T132

Incorporates 28A0083 R01

28-22-12

Page 2.2 Sheet 1 Aug 05/2009

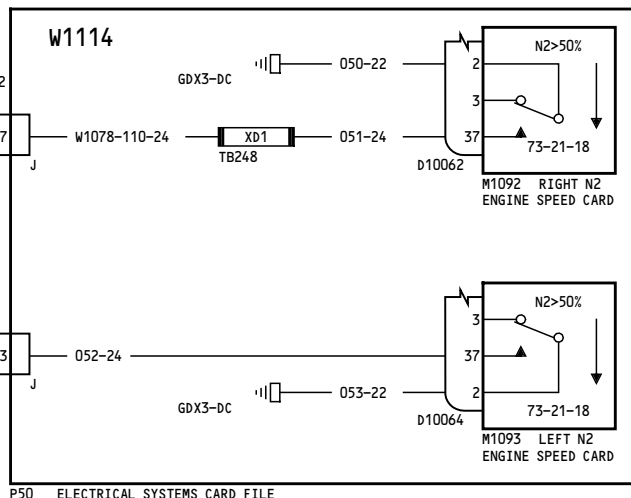
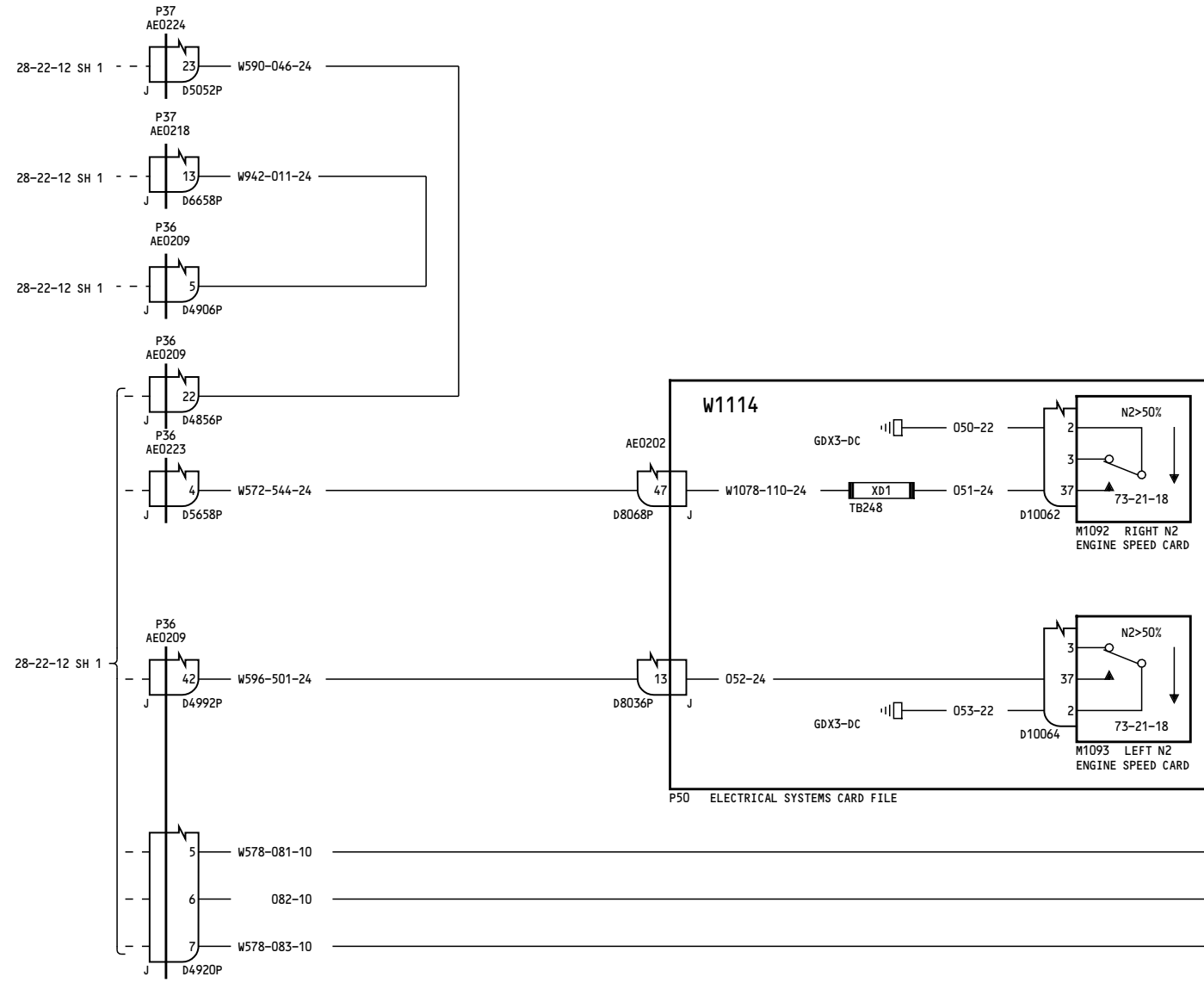
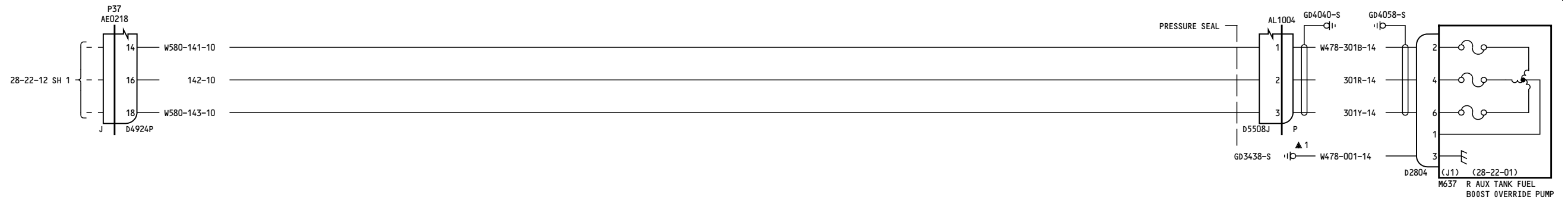

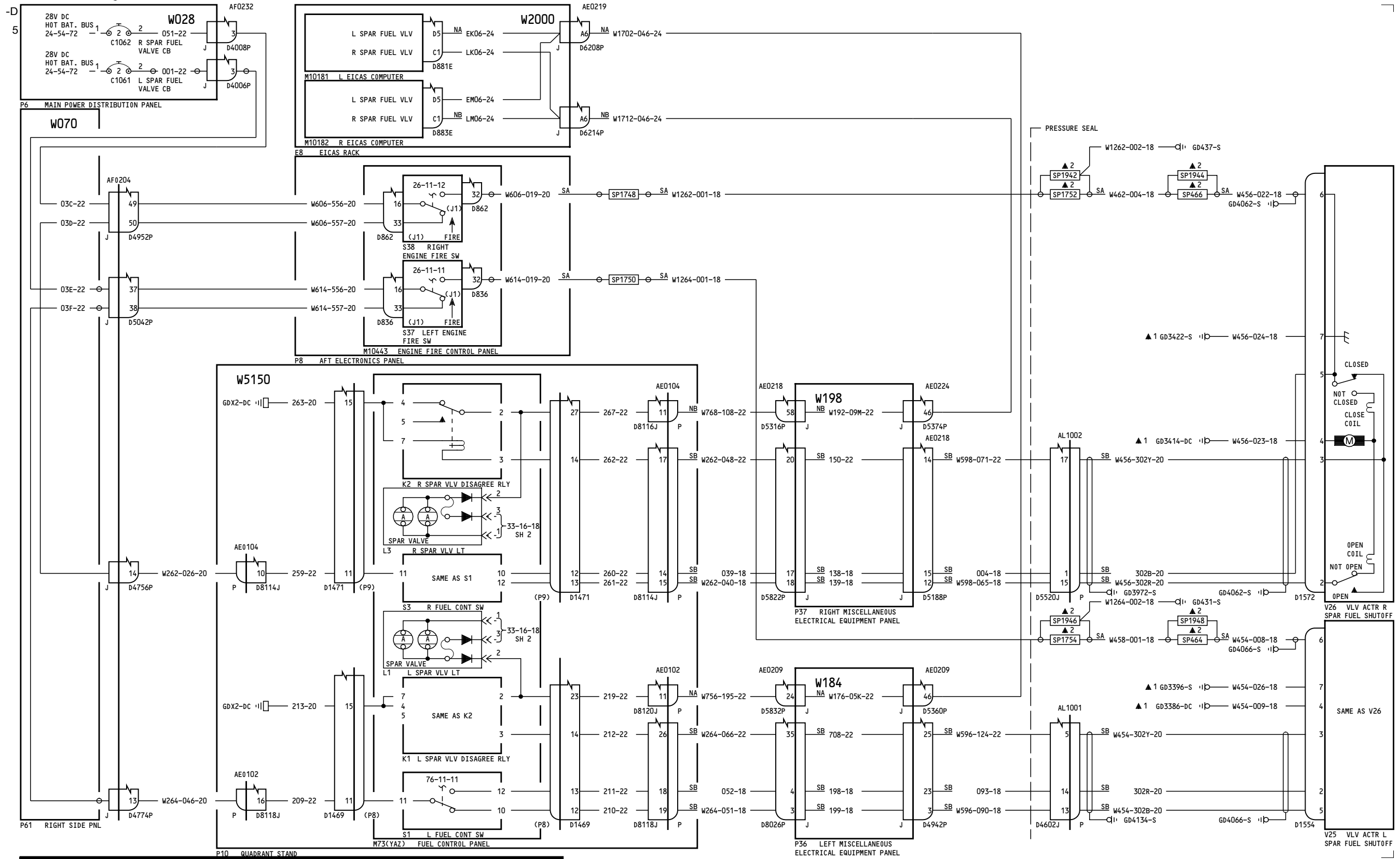

050-099, 150-156, 162-166, 275-276

**SPAR FUEL SHUTOFF VALVES ENGINES**

D280T132

**28-22-21**

Page 1

Jan 21/2005

**28-22-21**

Page 1

Jan 21/2005

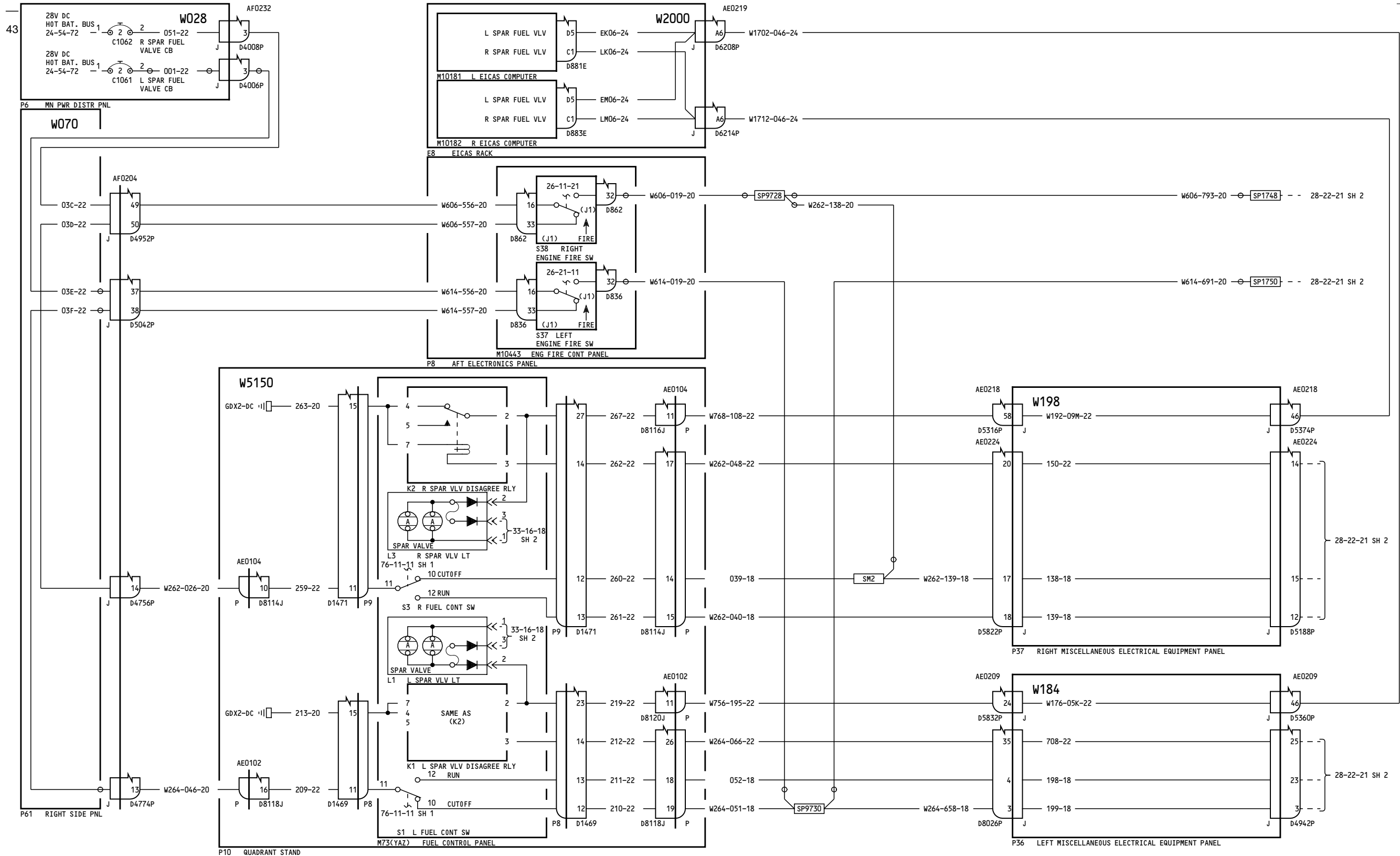

155, 163-164, 275-276

**SPAR FUEL SHUTOFF VALVES  
ENGINES**

D280T132

**28-22-21**

Page 1.1  
Sheet 1  
Mar 14/2007

Incorporates  
28-0066 R01

**28-22-21**

Page 1.1  
Sheet 1  
Mar 14/2007

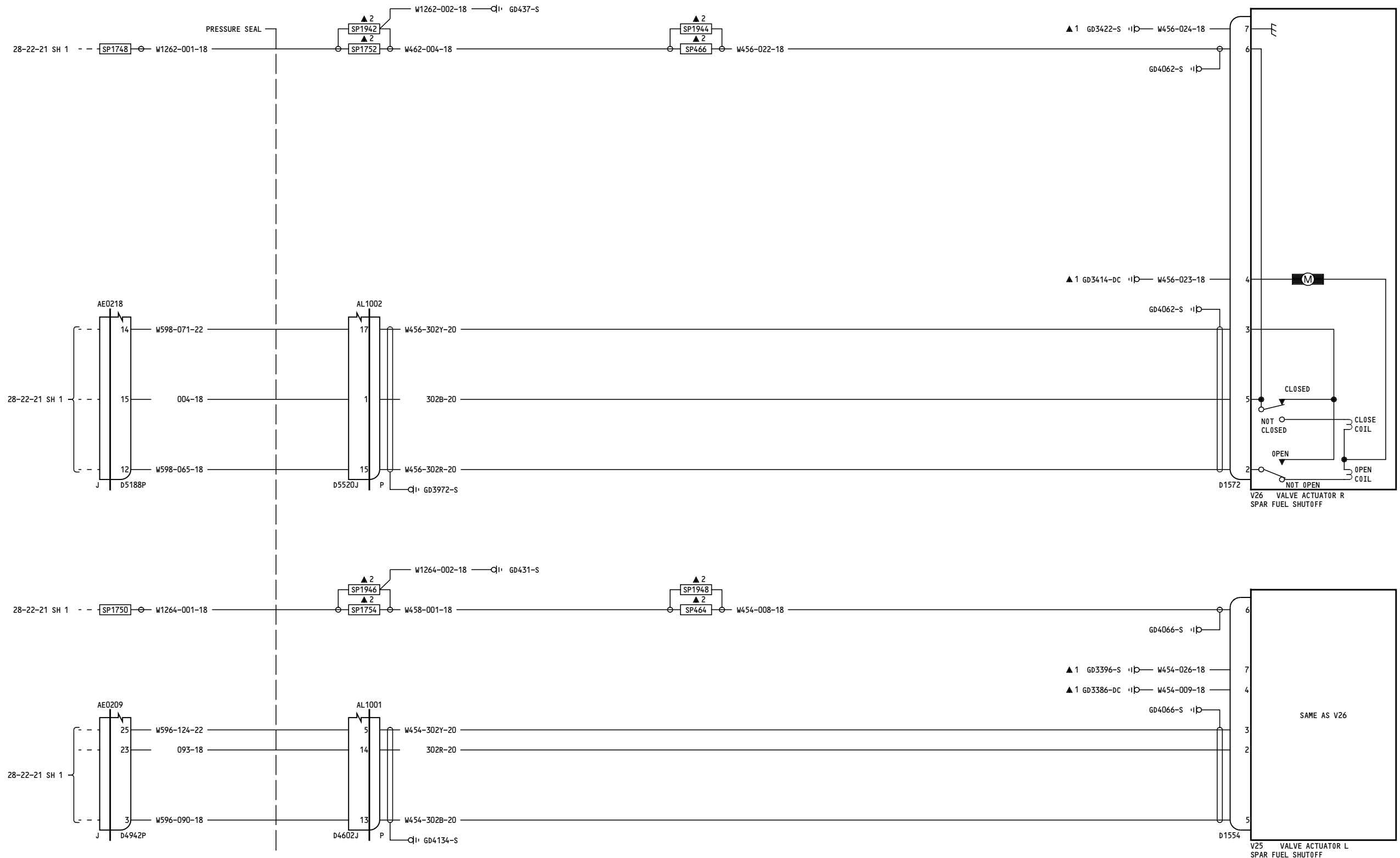

155, 163-164, 275-276

**SPAR FUEL SHUTOFF VALVES ENGINES**

D280T132

**28-22-21**

Page 1.1  
Sheet 2  
Mar 14/2007

Incorporates  
28-0066 R01

**28-22-21**

Page 1.1  
Sheet 2  
Mar 14/2007

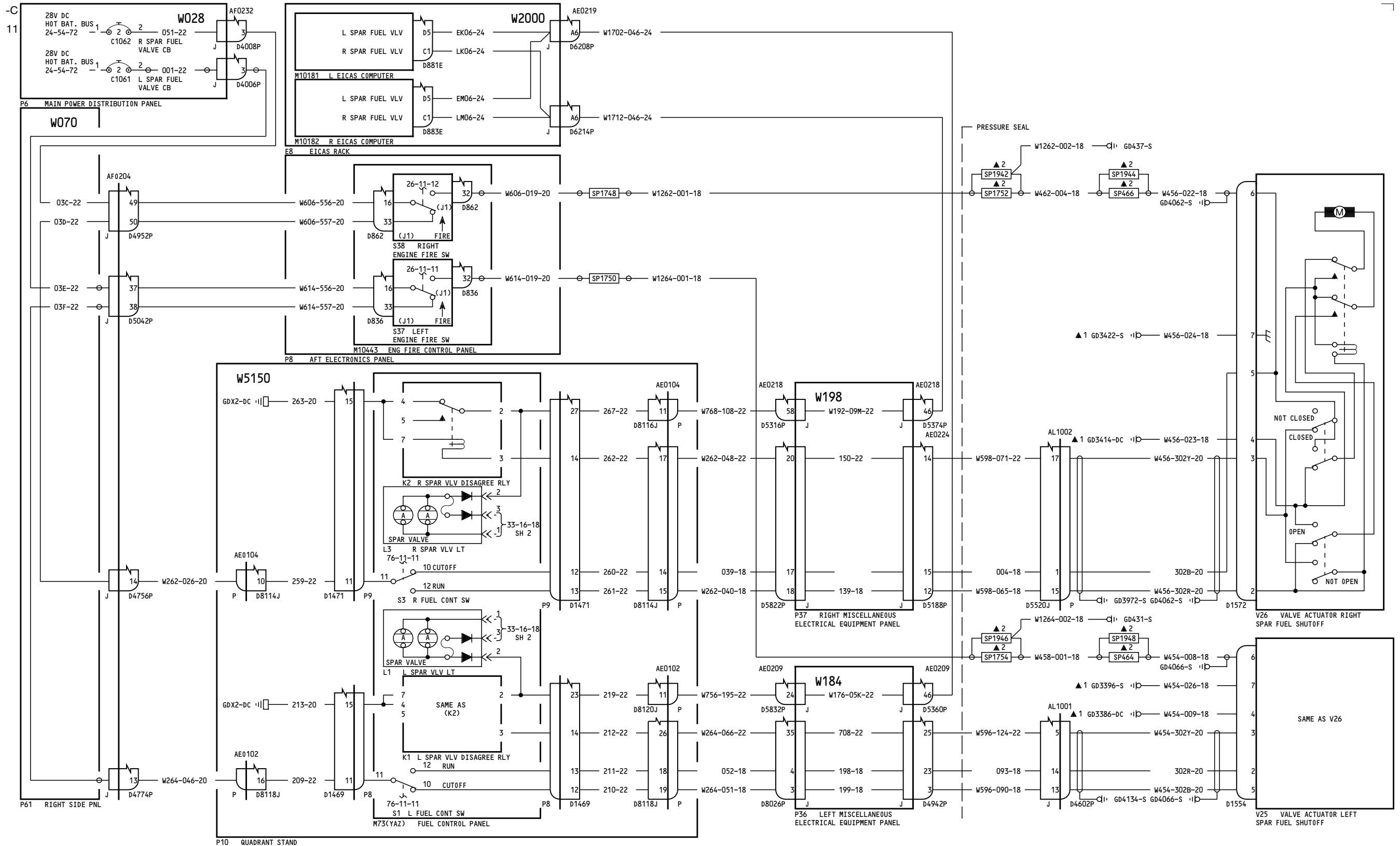

157, 167-199, 277-299

**SPAR FUEL SHUTOFF VALVES ENGINES**

**28-22-21**

Page 2

D280T132

Mar 09/2006

**28-22-21**

Page 2

Mar 09/2006

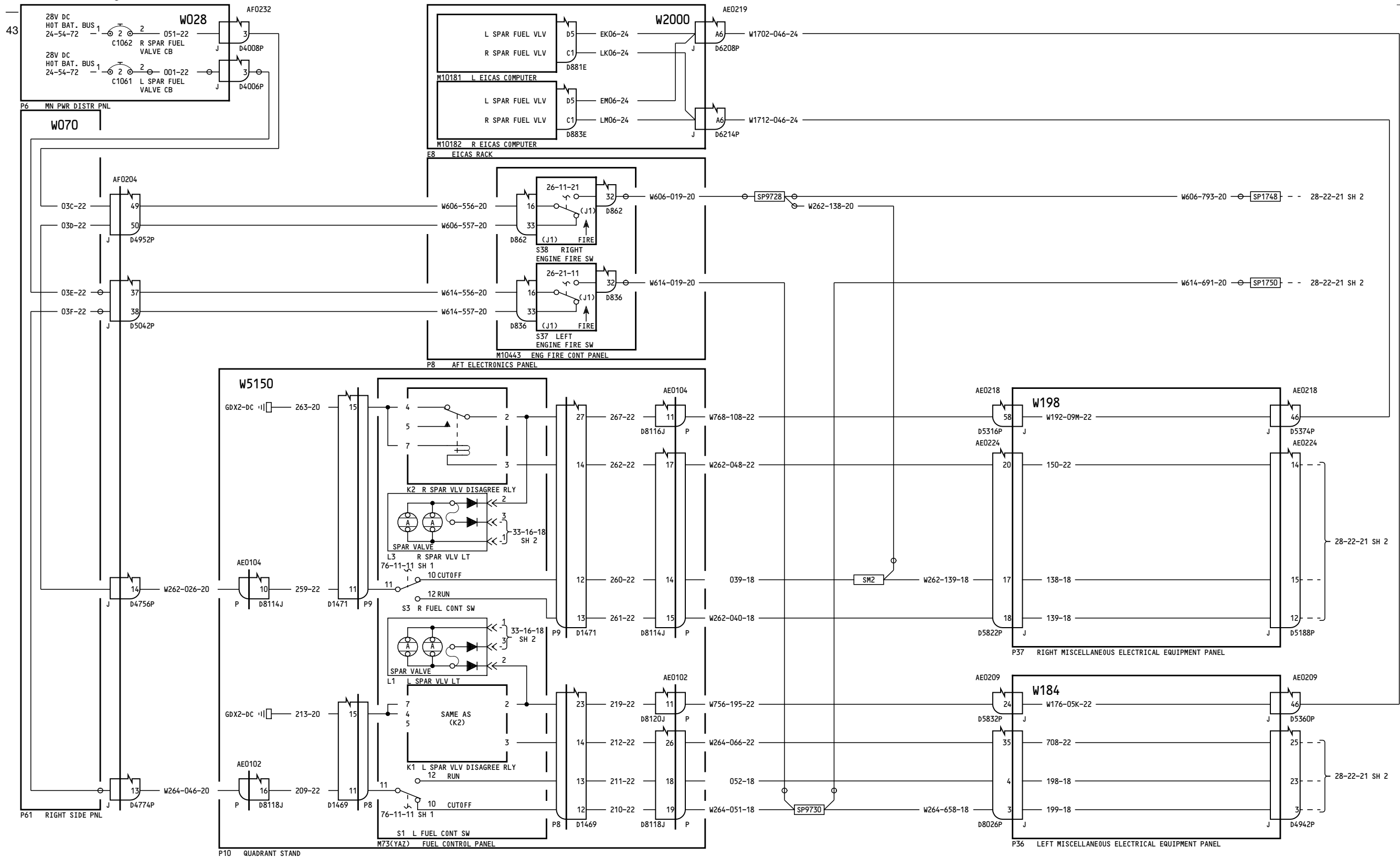

277-280

**SPAR FUEL SHUTOFF VALVES ENGINES**

D280T132

**28-22-21**

Page 2.1  
Sheet 1  
Mar 14/2007

Incorporates  
28-0066 R01

**28-22-21**

Page 2.1  
Sheet 1  
Mar 14/2007

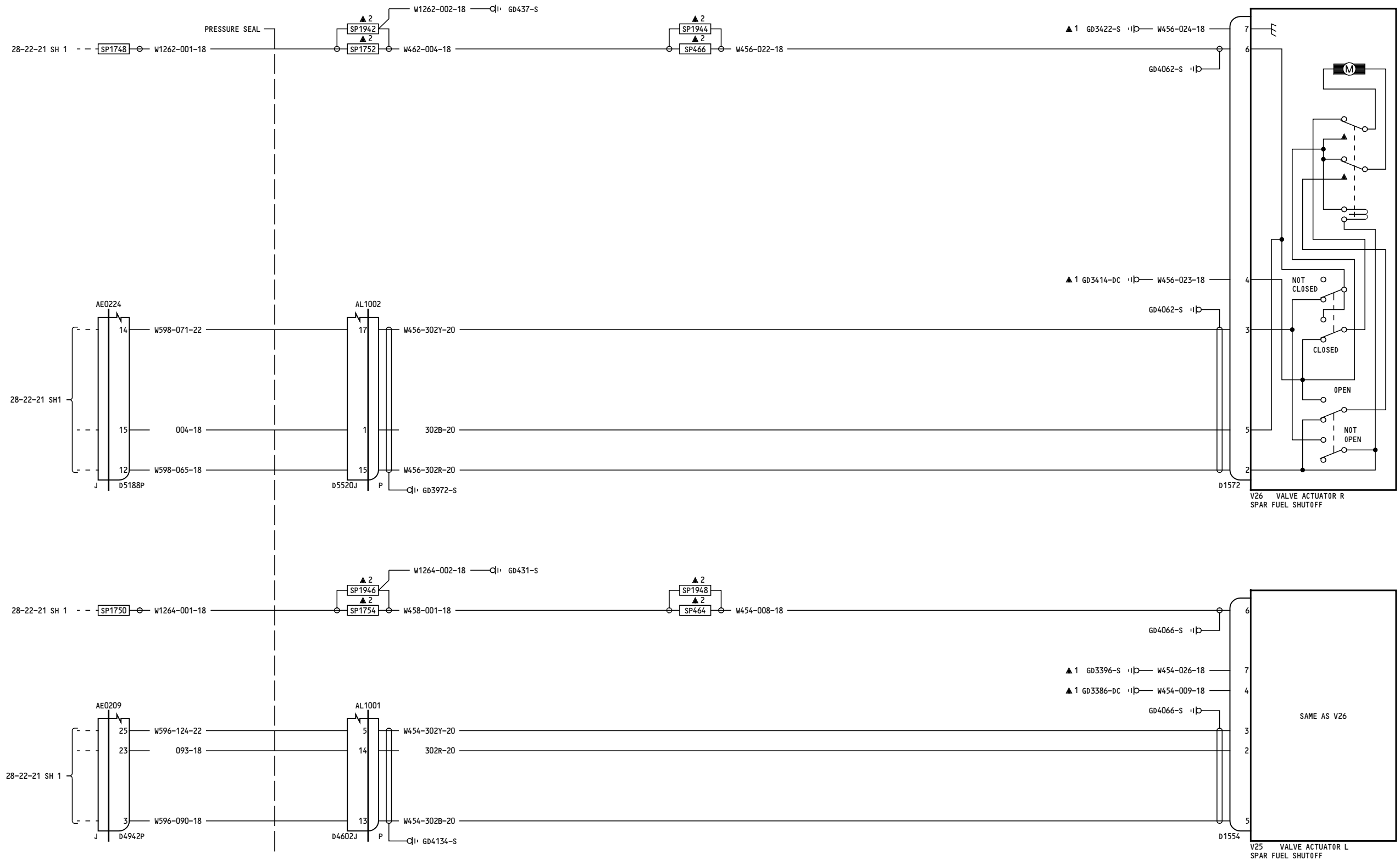

277-280

**SPAR FUEL SHUTOFF VALVES ENGINES**

D280T132

**28-22-21**

Page 2.1  
Sheet 2  
Mar 14/2007

Incorporates  
28-0066 R01

**28-22-21**

Page 2.1  
Sheet 2  
Mar 14/2007



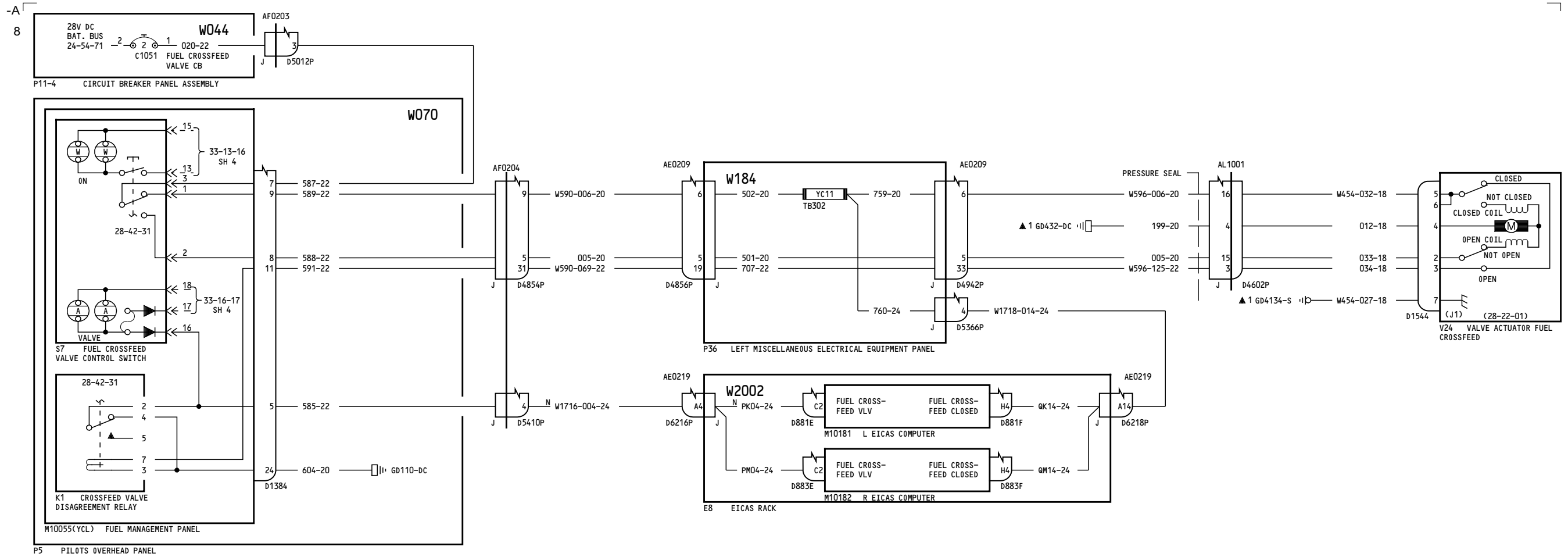

050-099, 155-156, 162-166

**FUEL CROSSFEED VALVES**

**28-22-31**

Page 1

Jan 21/2005

D280T132

**28-22-31**

Page 1

Jan 21/2005

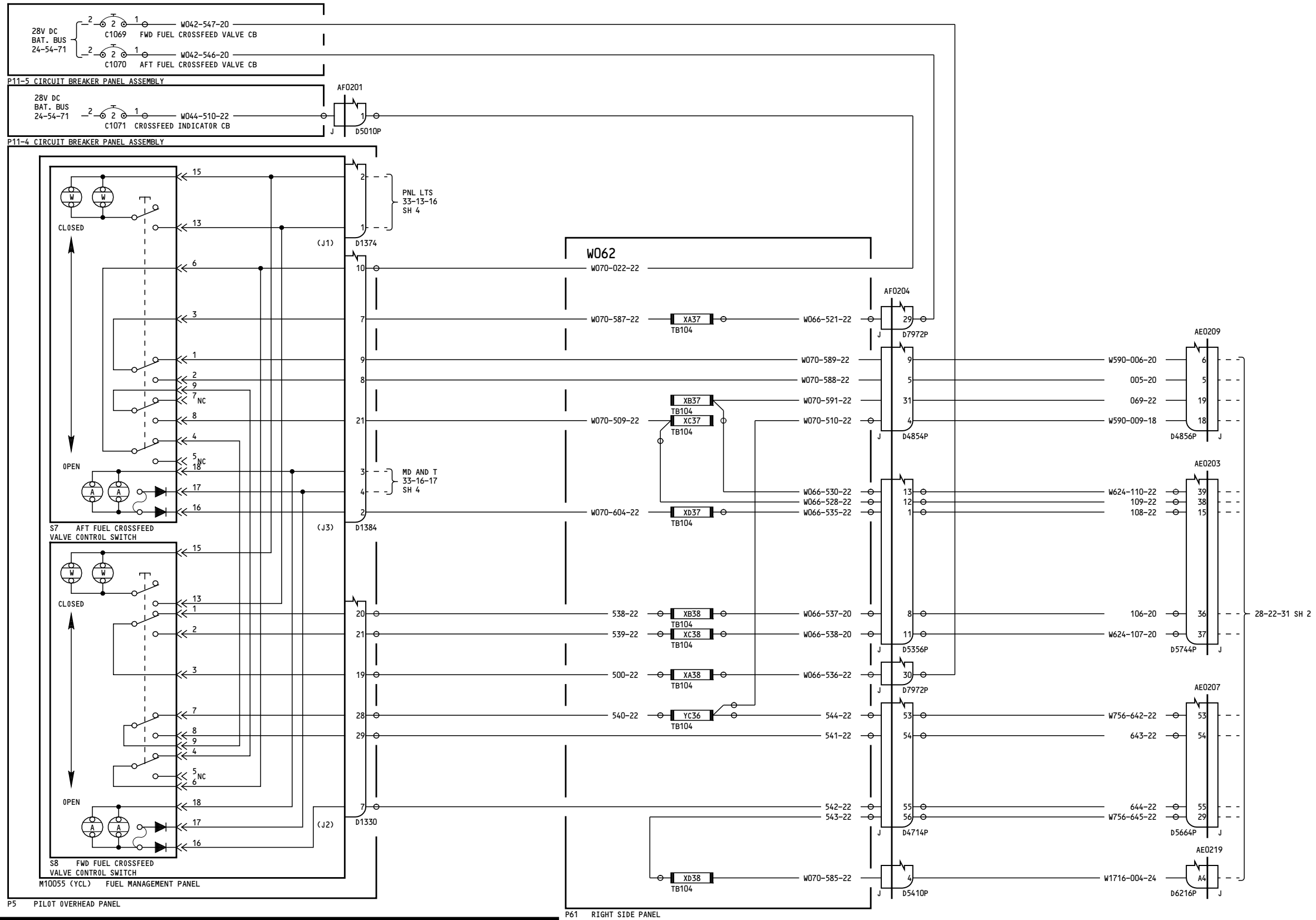

050-280

**FUEL CROSSFEED VALVES**

D280T132

**28-22-31**

Page 1.1  
Sheet 1  
Jan 21/2005

Incorporates  
28-0034 R02

**28-22-31**

Page 1.1  
Sheet 1  
Jan 21/2005

43

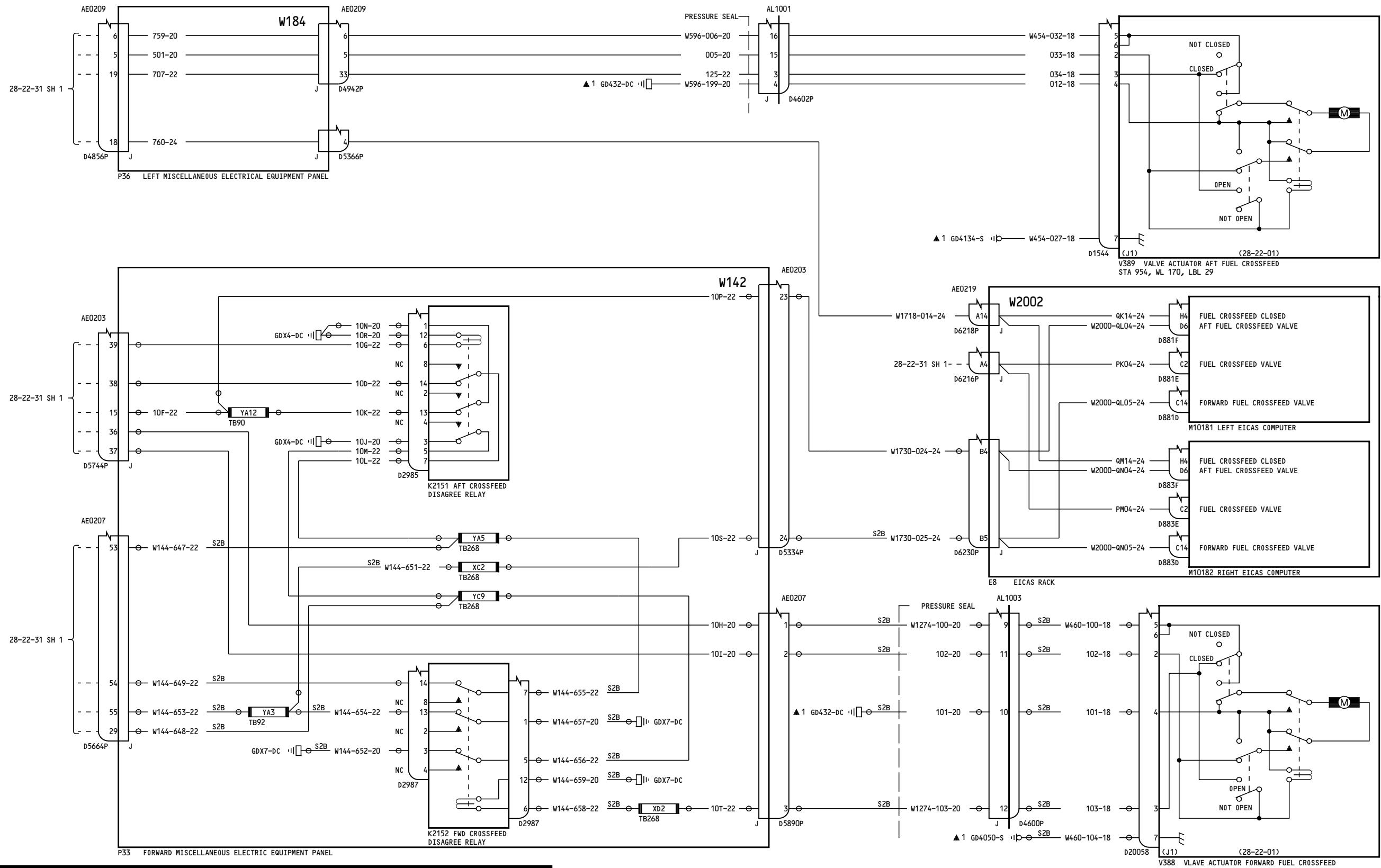

050-280

**FUEL CROSSFEED VALVES**

D280T132

**28-22-31**

Page 1.1  
Sheet 2  
Jan 21/2005

Incorporates  
28-0034 R02

**28-22-31**

Page 1.1  
Sheet 2  
Jan 21/2005

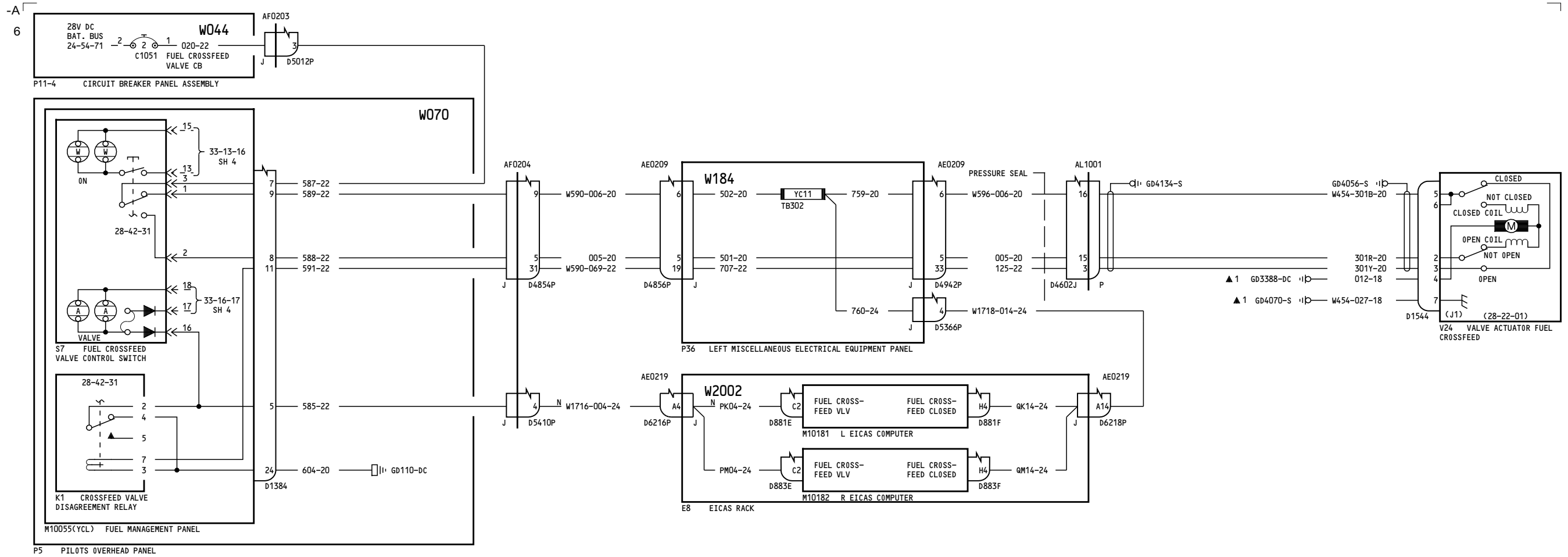

150-154, 275-276

**FUEL CROSSFEED VALVES**

**28-22-31**

**28-22-31**

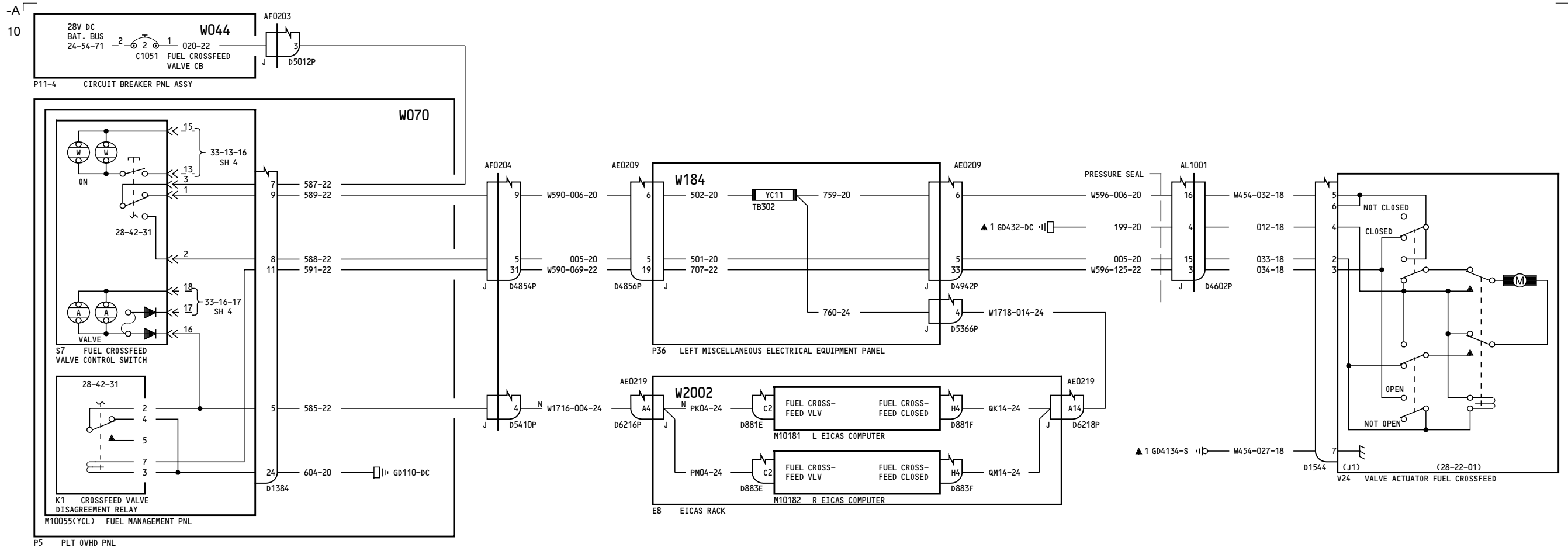

157, 167-199, 277-299

**FUEL CROSSFEED VALVES**

**28-22-31**

Page 3

Jan 21/2005

D280T132

**28-22-31**

Page 3

Jan 21/2005

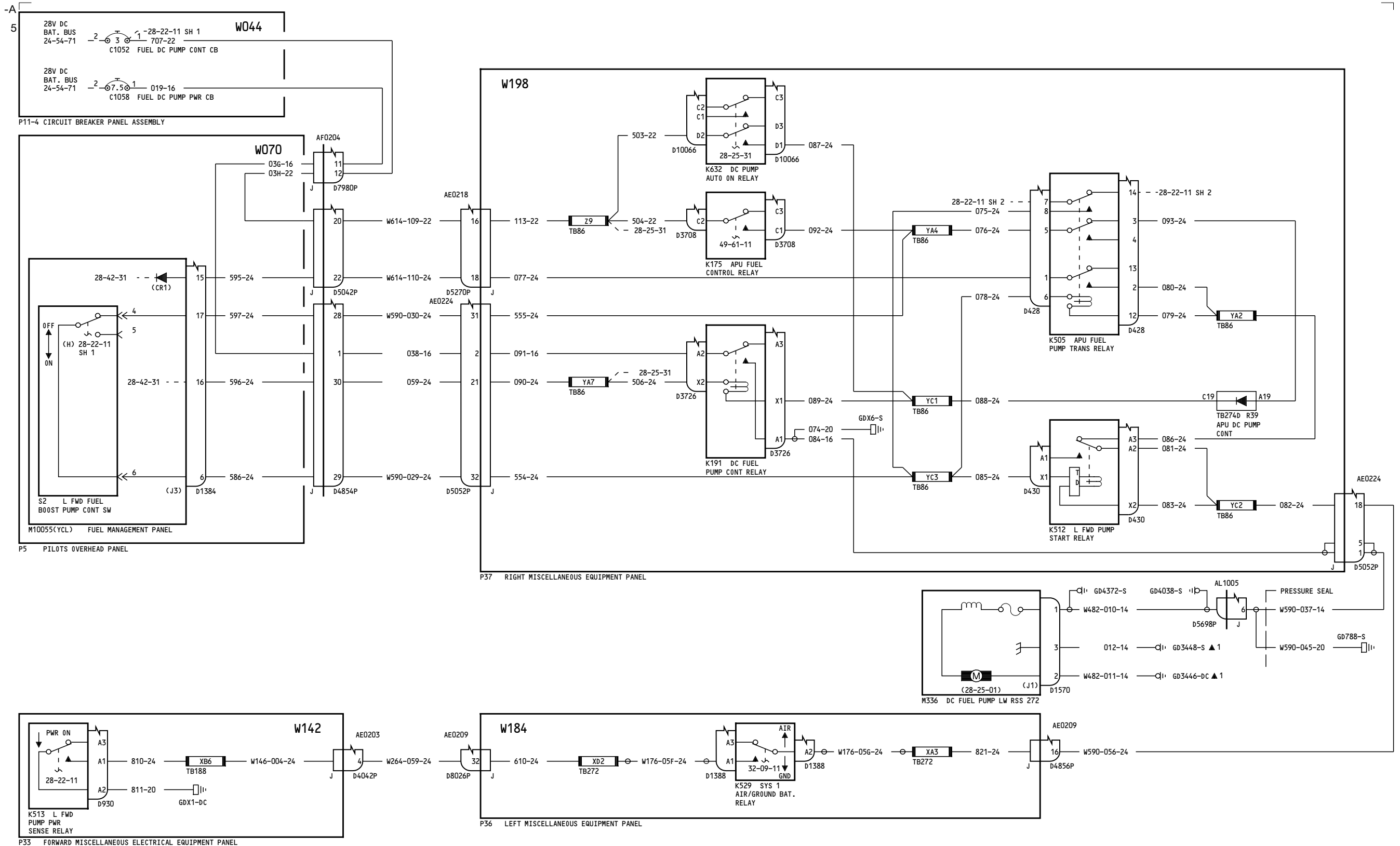

050-099

**DC FUEL PUMP-APU**

D280T132

**28-25-11**

Page 1

Jan 21/2005

**28-25-11**

Page 1

Jan 21/2005

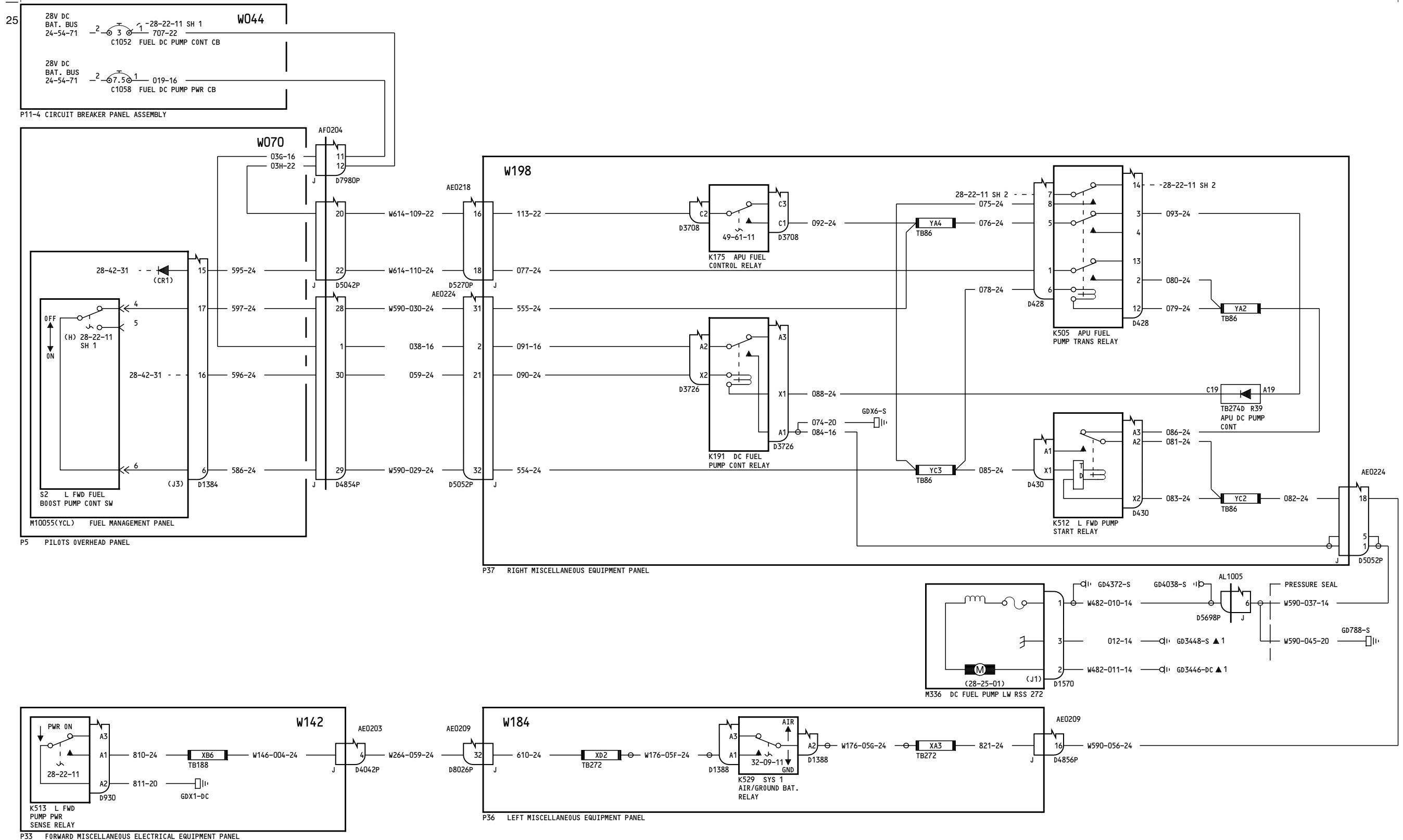

050-051

**DC FUEL PUMP-  
APU**

**28-25-11**

Incorporates  
28-0034 R02

**28-25-11**

Page 1.1

Page 1.1

D280T132

Jan 21/2005

Jan 21/2005

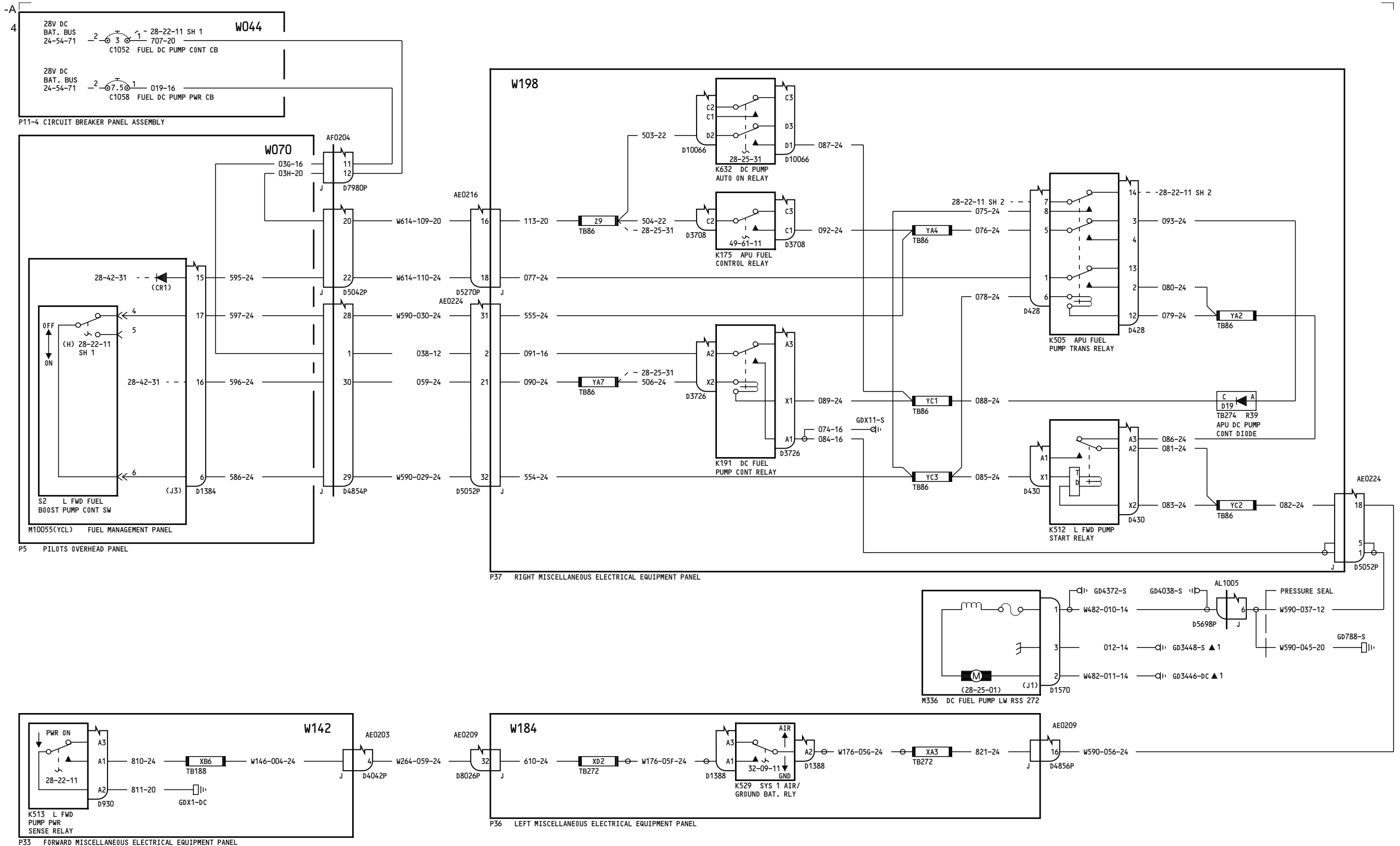

150-154, 275

**DC FUEL PUMP-APU**

D280T132

**28-25-11**

Page 2

Jan 21/2005

**28-25-11**

Page 2

Jan 21/2005



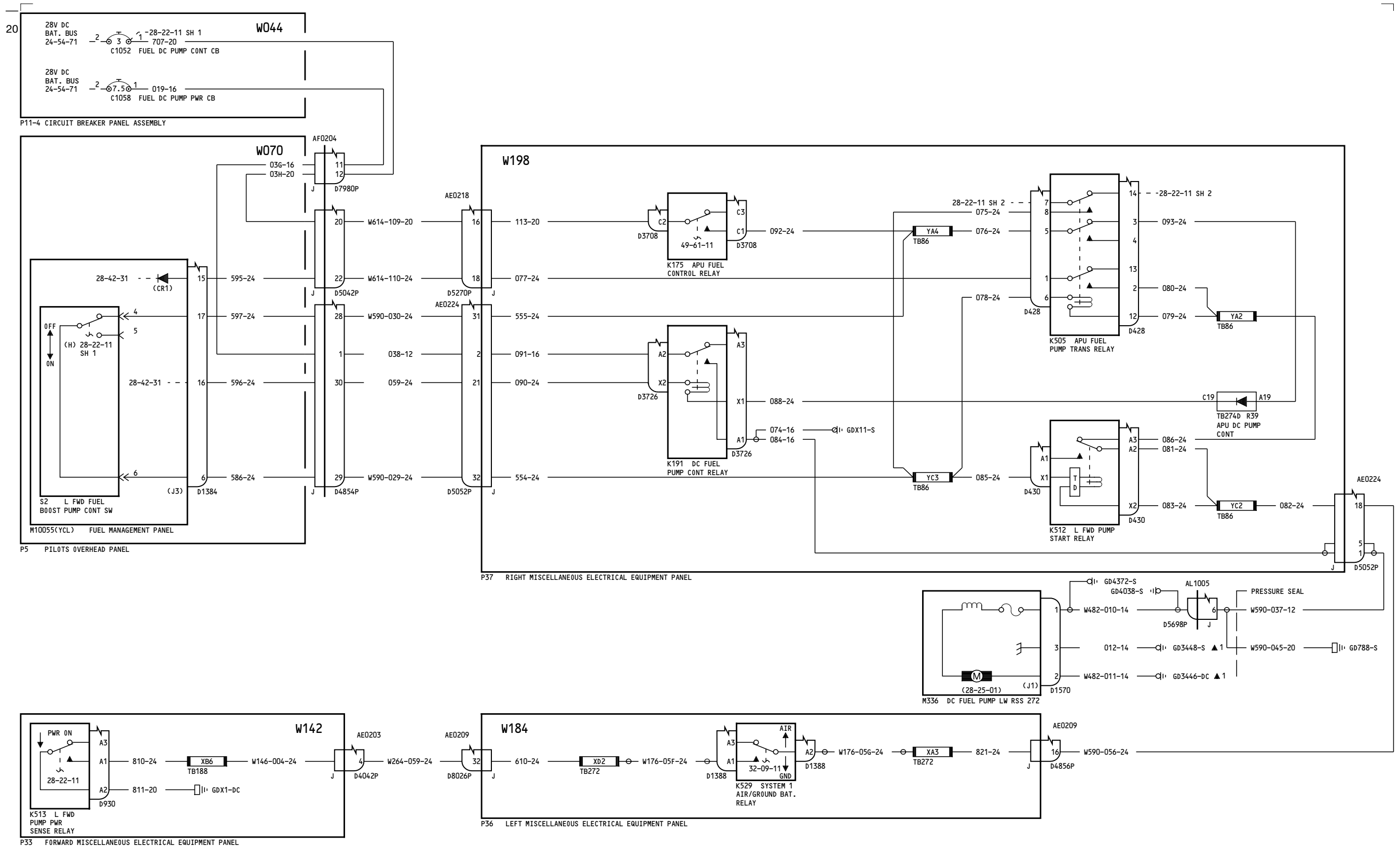

150-154, 275

**DC FUEL PUMP-  
APU**

D280T132

**28-25-11**

Page 2.1

Jan 21/2005

Incorporates  
28-0034 R02

**28-25-11**

Page 2.1

Jan 21/2005

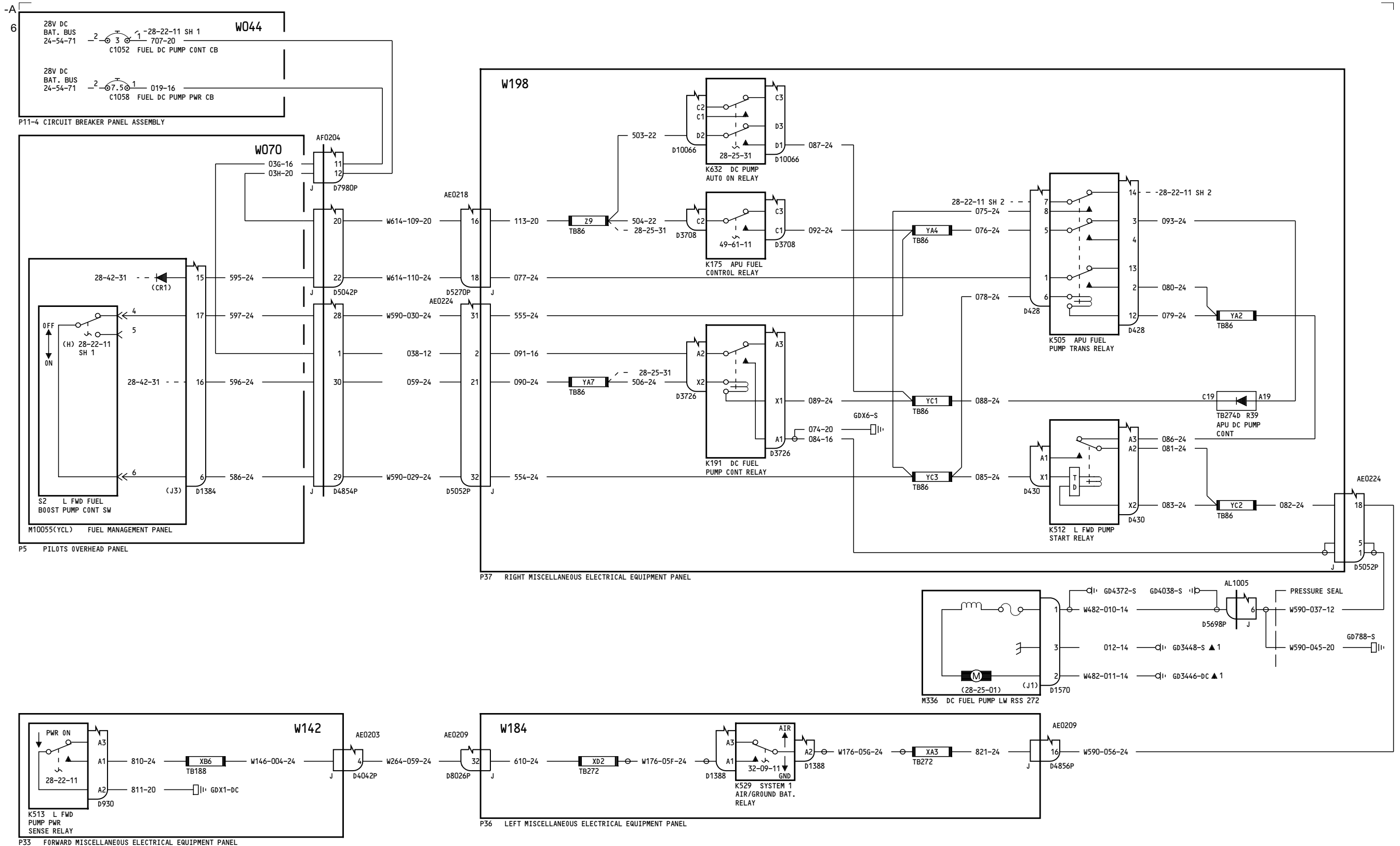

155-199, 276-299

**DC FUEL PUMP-APU**

**28-25-11**

Page 3

Jan 21/2005

D280T132

**28-25-11**

Page 3

Jan 21/2005

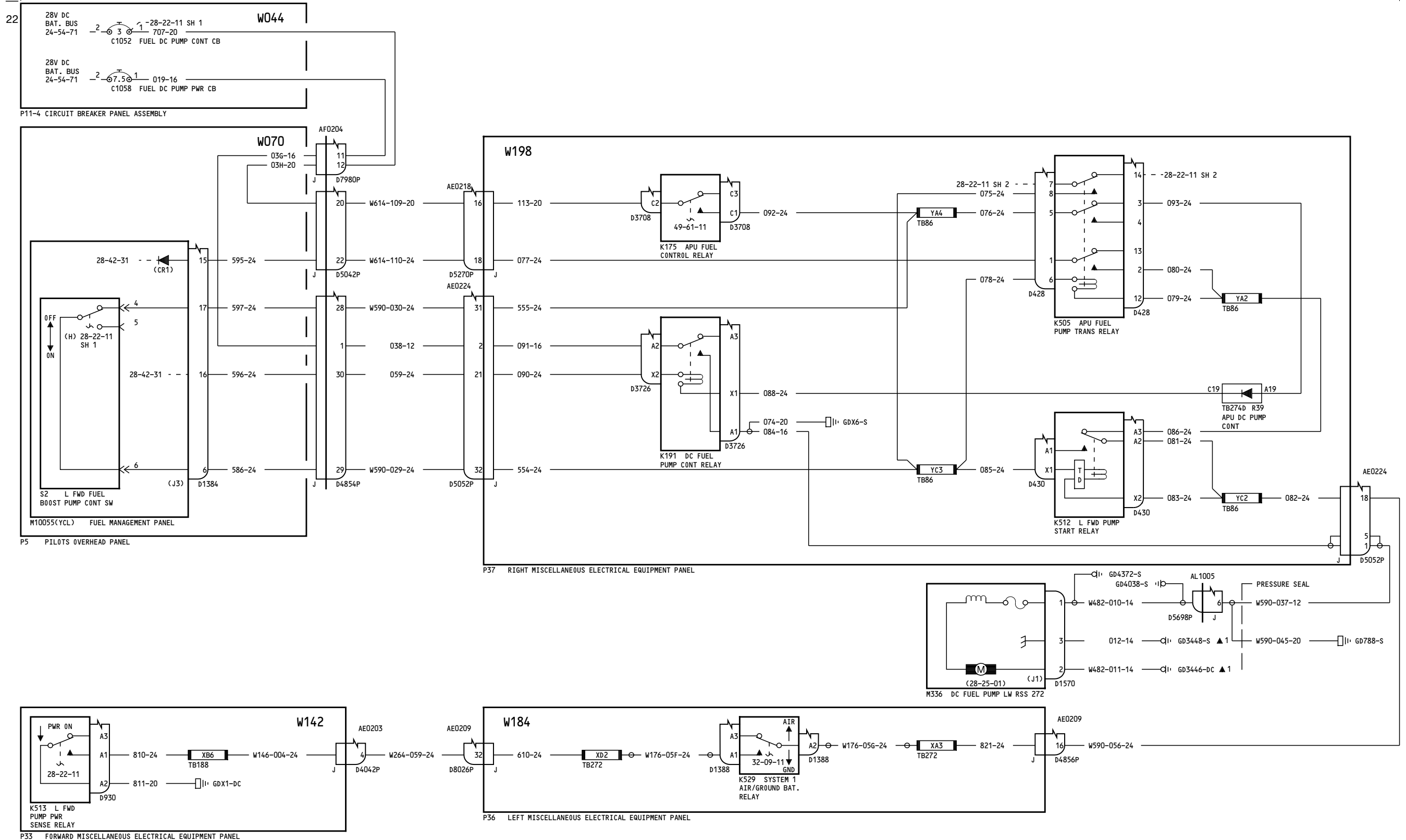

155-167, 276-280

**DC FUEL PUMP-  
APU**

D280T132

**28-25-11**

Page 3.1

Jan 21/2005

Incorporates  
28-0034 R02

**28-25-11**

Page 3.1

Jan 21/2005

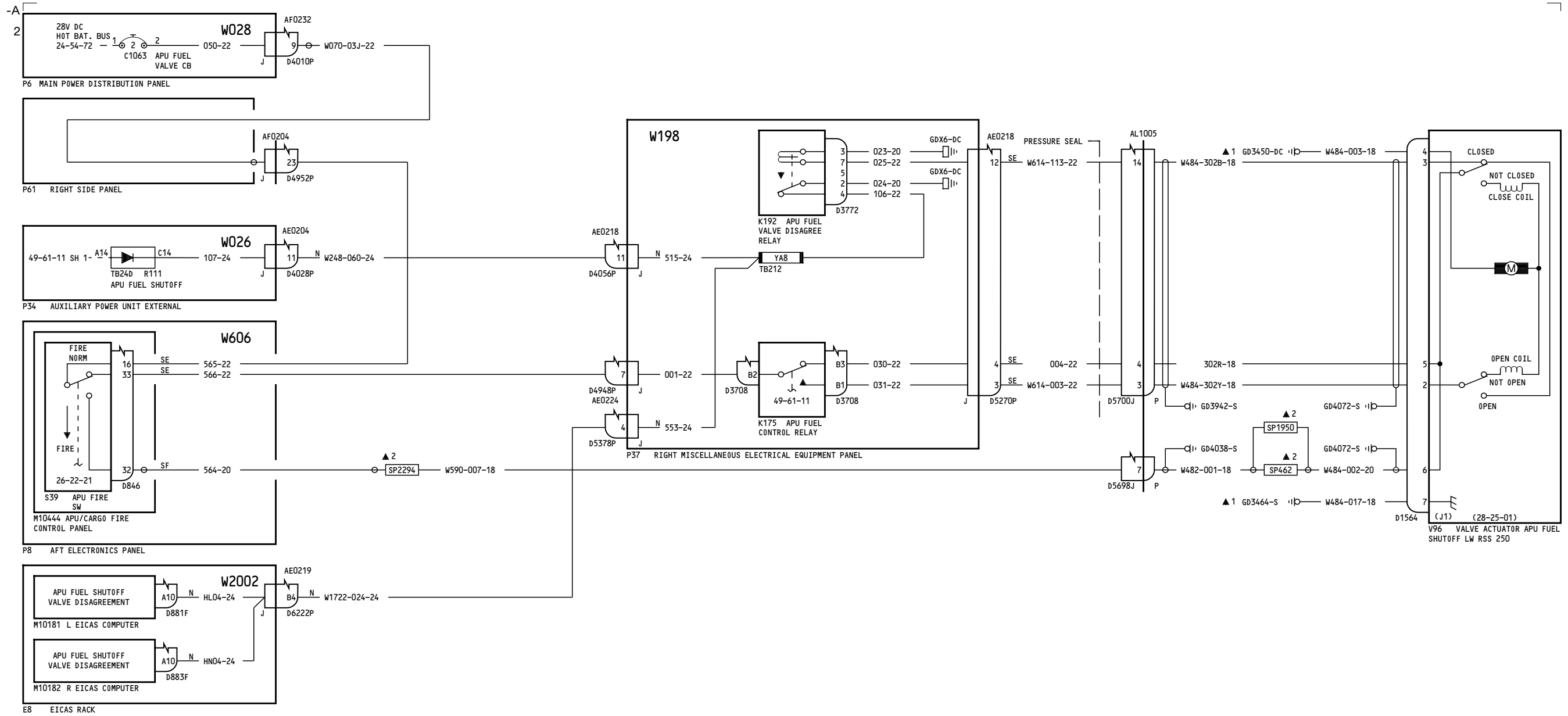

050-099

FUEL SHUTOFF VALVE-  
APU

28-25-21

Page 1

Jan 21/2005

D280T132

28-25-21

Page 1

Jan 21/2005

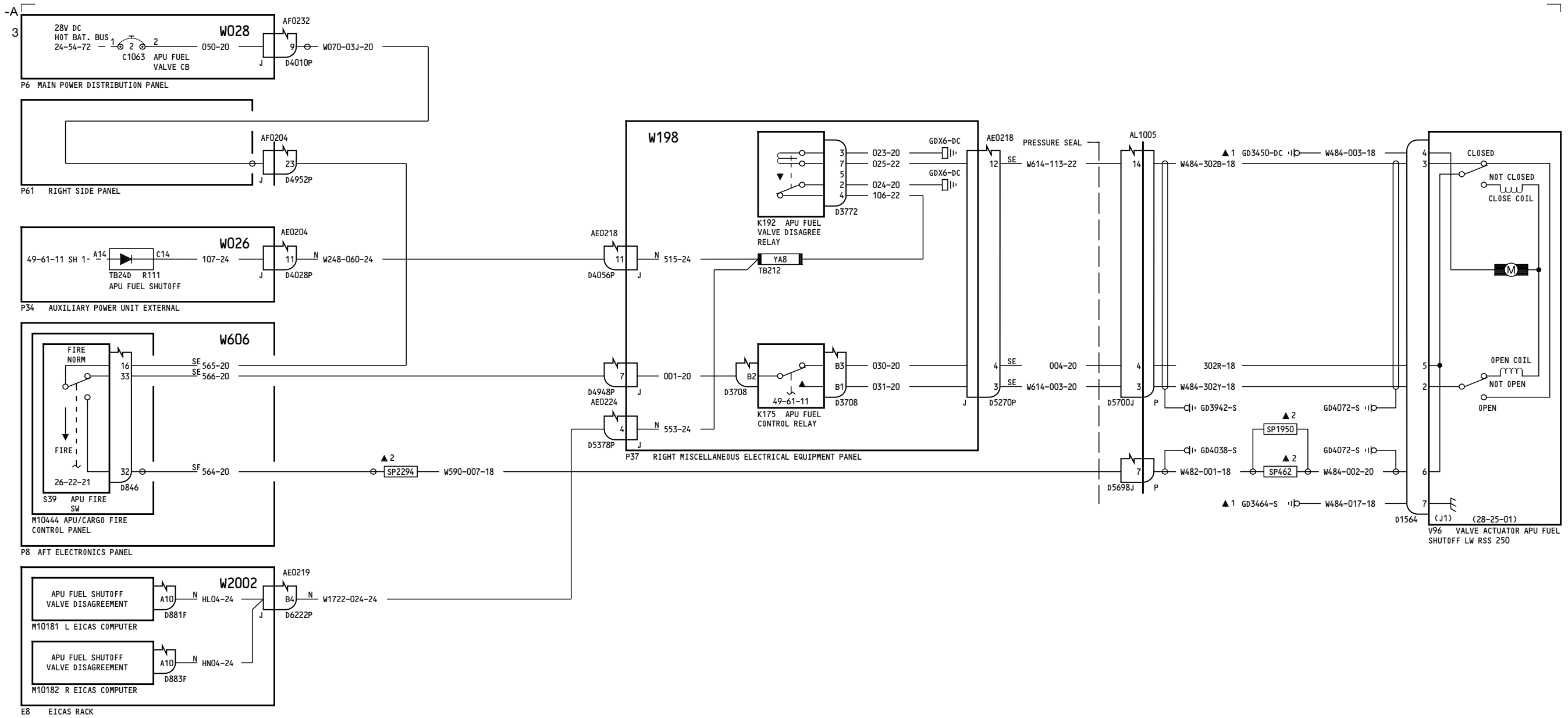

150-156, 162-166, 275-276

FUEL SHUTOFF VALVE-APU

D280T132

28-25-21

Page 2

Jan 21/2005

28-25-21

Page 2

Jan 21/2005

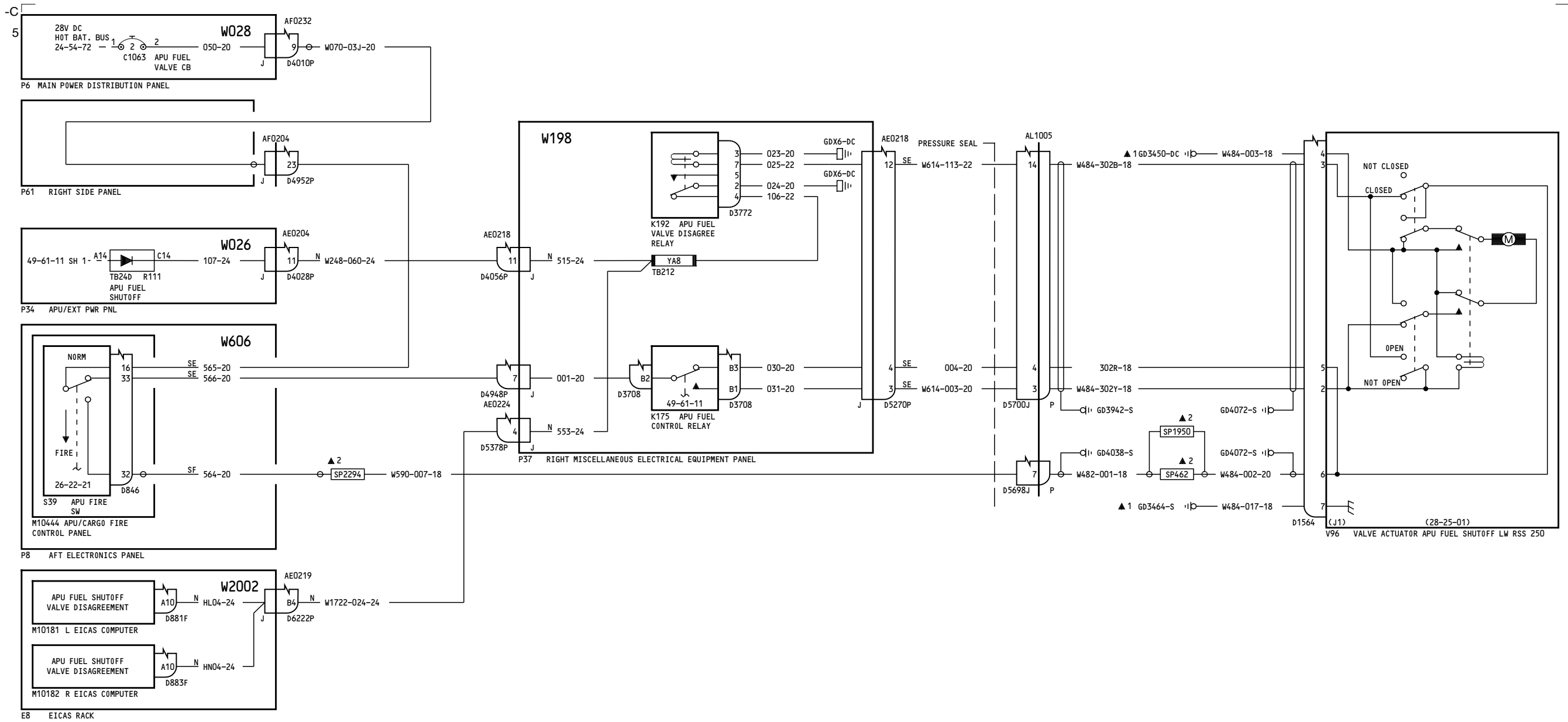

157, 167-199, 277-299

FUEL SHUTOFF VALVE-  
APU

28-25-21

Page 3

D280T132

Jan 21/2005

28-25-21

Page 3

Jan 21/2005

-A  
7

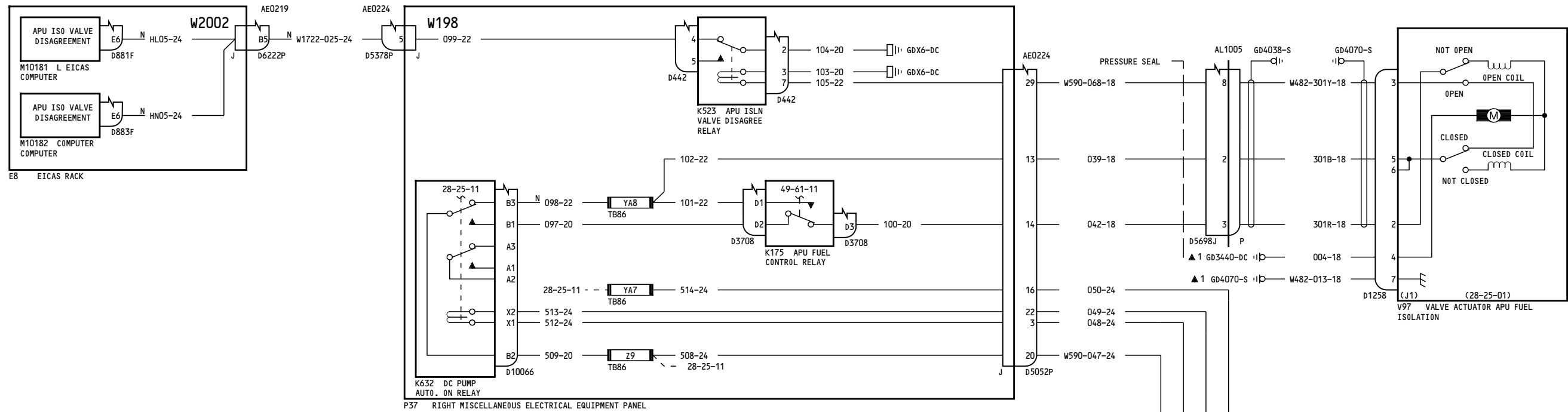

050-051, 155-156, 162-166

**FUEL ISOLATION VALVE-  
APU**

**28-25-31**

Incorporates  
28-0034 R02

**28-25-31**

D280T132

Page 1.1

Page 1.1

Jan 21/2005

Jan 21/2005

17

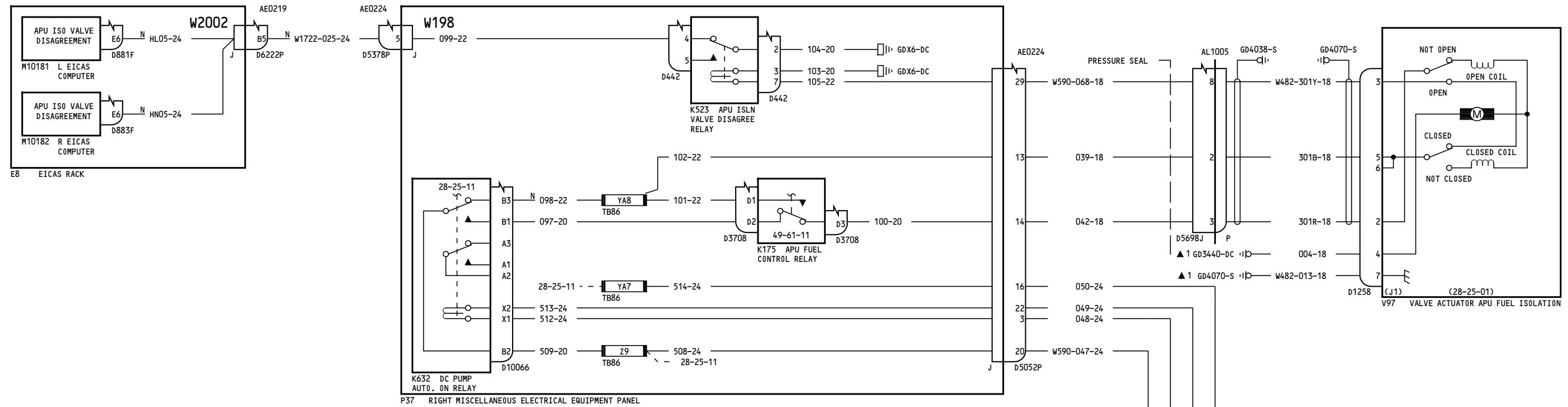

150-154

**FUEL ISOLATION VALVE-  
APU**

D280T132

**28-25-31**

Page 2.1

Jan 21/2005

Incorporates  
 28-0034 R02  
 76-0030 R02

**28-25-31**

Page 2.1

Jan 21/2005



-A  
13

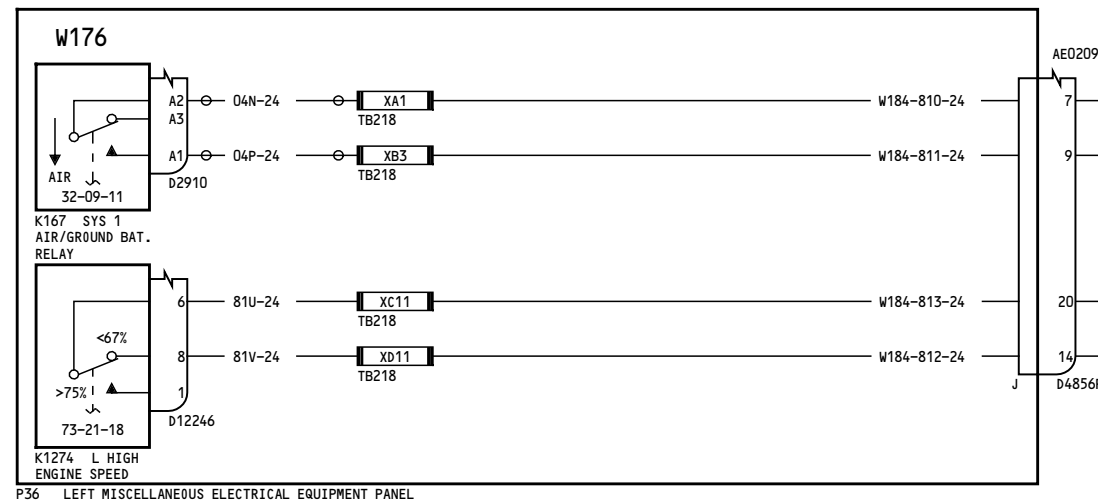
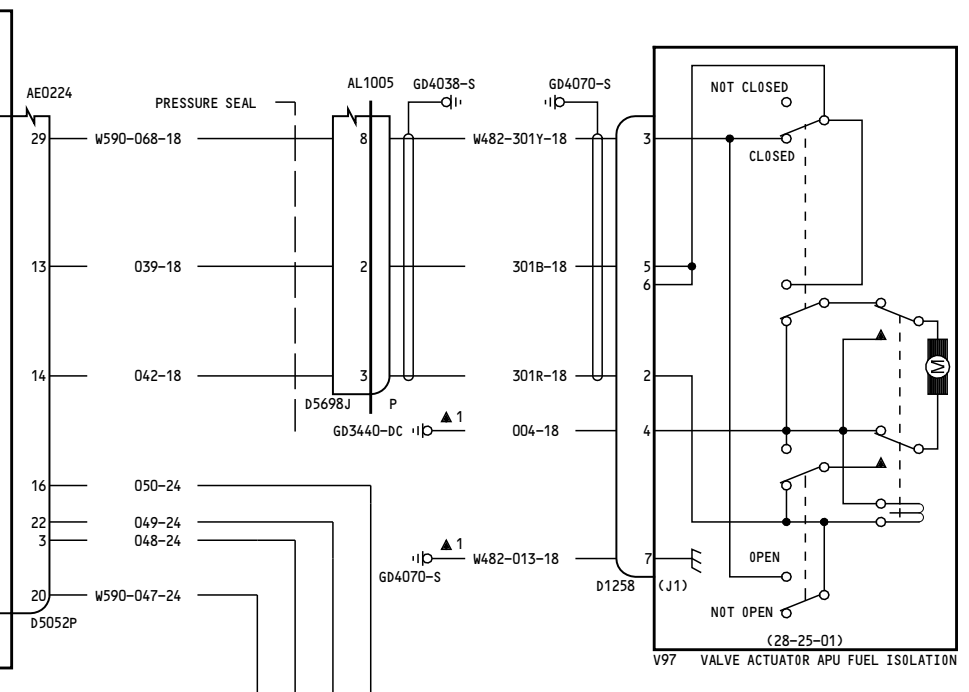
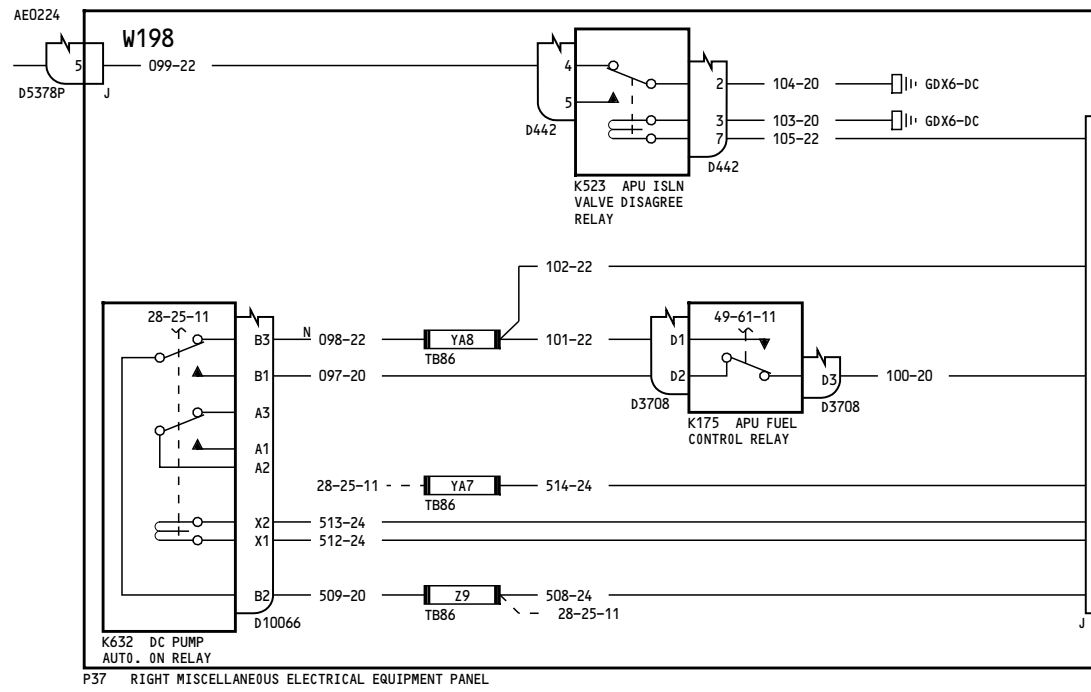
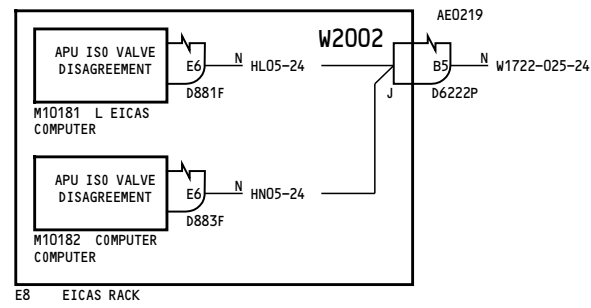

157, 167, 277-280

FUEL ISOLATION VALVE-  
APU

D280T132

28-25-31

Page 3.1

Jan 21/2005

Incorporates  
28-0034 R02

28-25-31

Page 3.1

Jan 21/2005

16

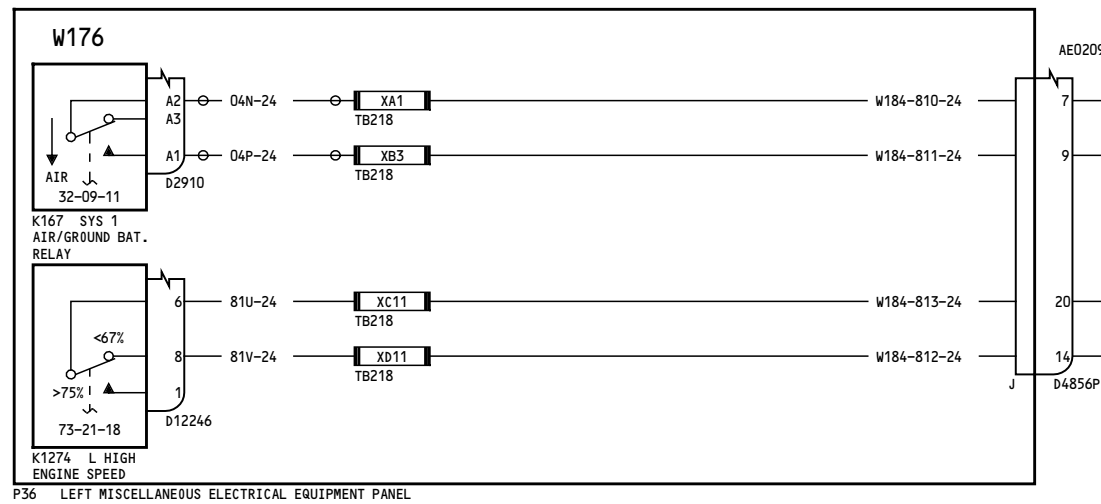
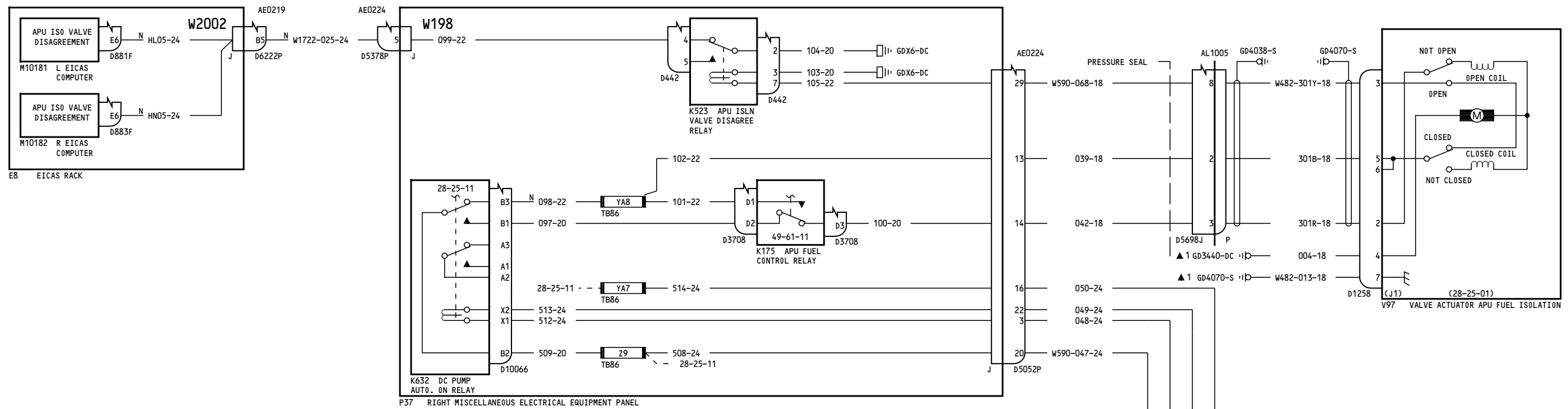

275-276

**FUEL ISOLATION VALVE-APU**

D280T132

**28-25-31**

Page 4.1

Jan 21/2005

Incorporates  
 28-0034 R02  
 76-0026

**28-25-31**

Page 4.1

Jan 21/2005

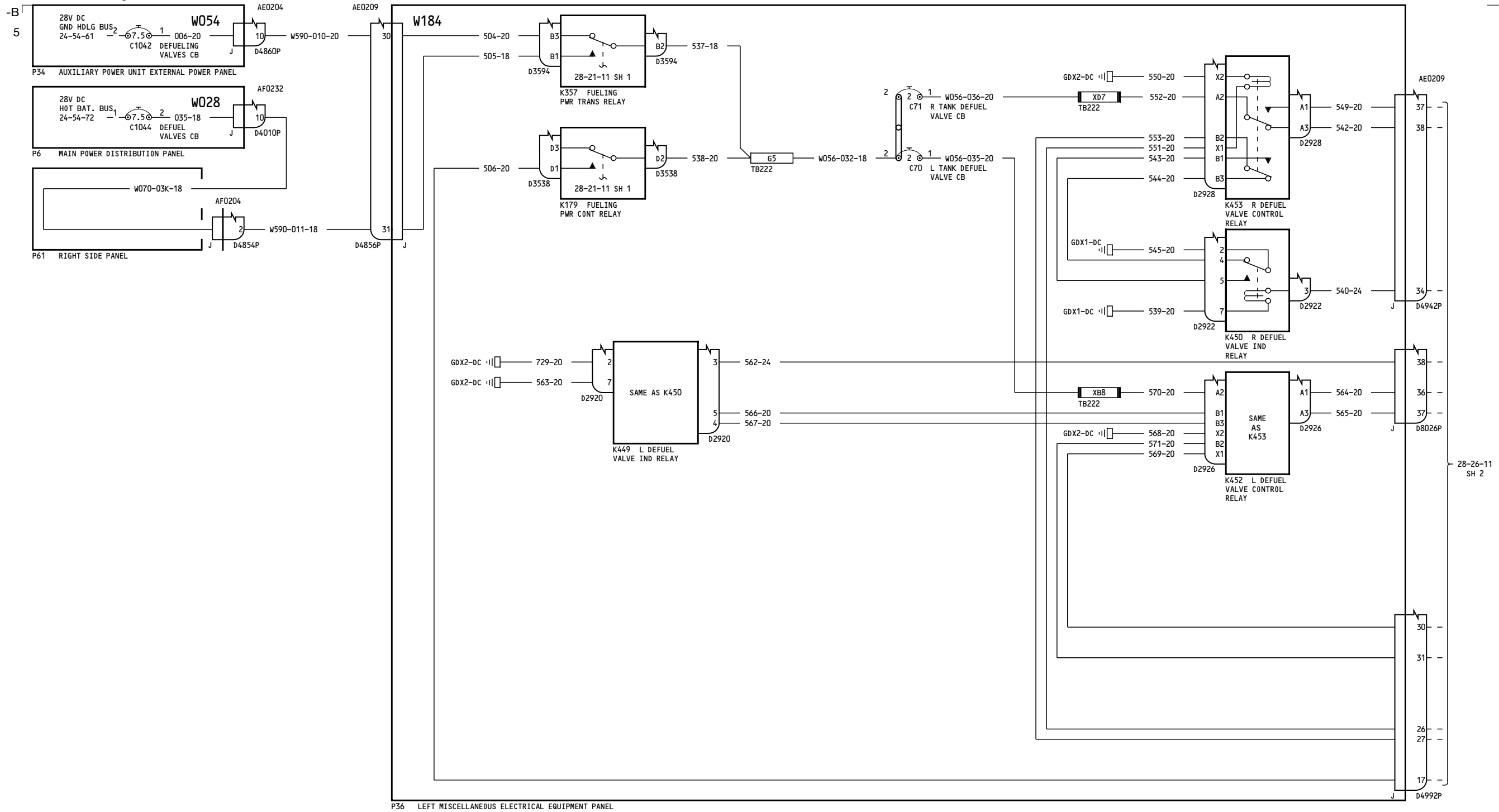

050-099, 150-156, 162-166, 275-276

**DEFUELING VALVES**

**28-26-11**

Page 1  
Sheet 1  
Jan 21/2005

D280T132

**28-26-11**

Page 1  
Sheet 1  
Jan 21/2005

-C  
5

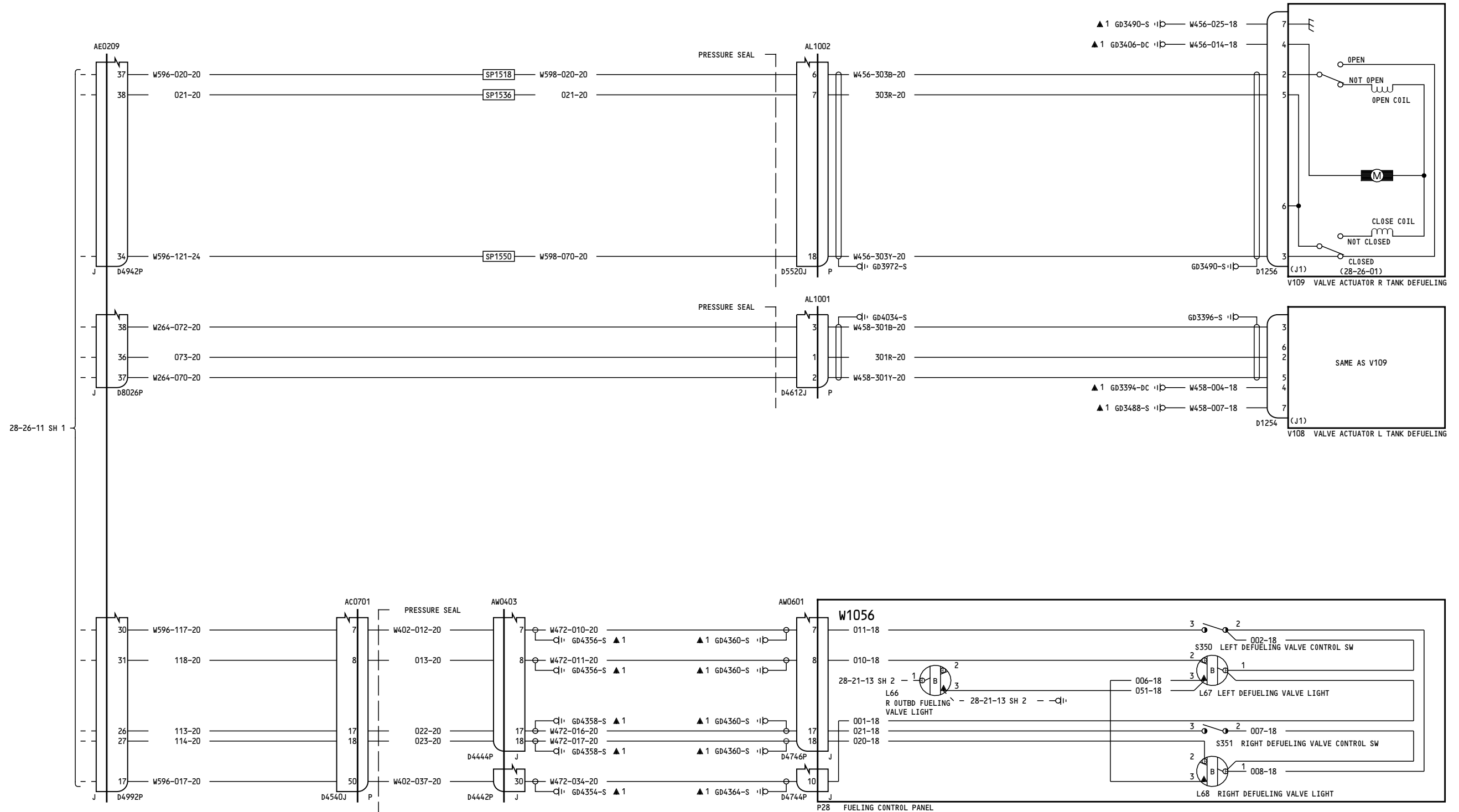

050-099, 150-156, 162-166, 275-276

DEFUELING VALVES

28-26-11

D280T132

28-26-11

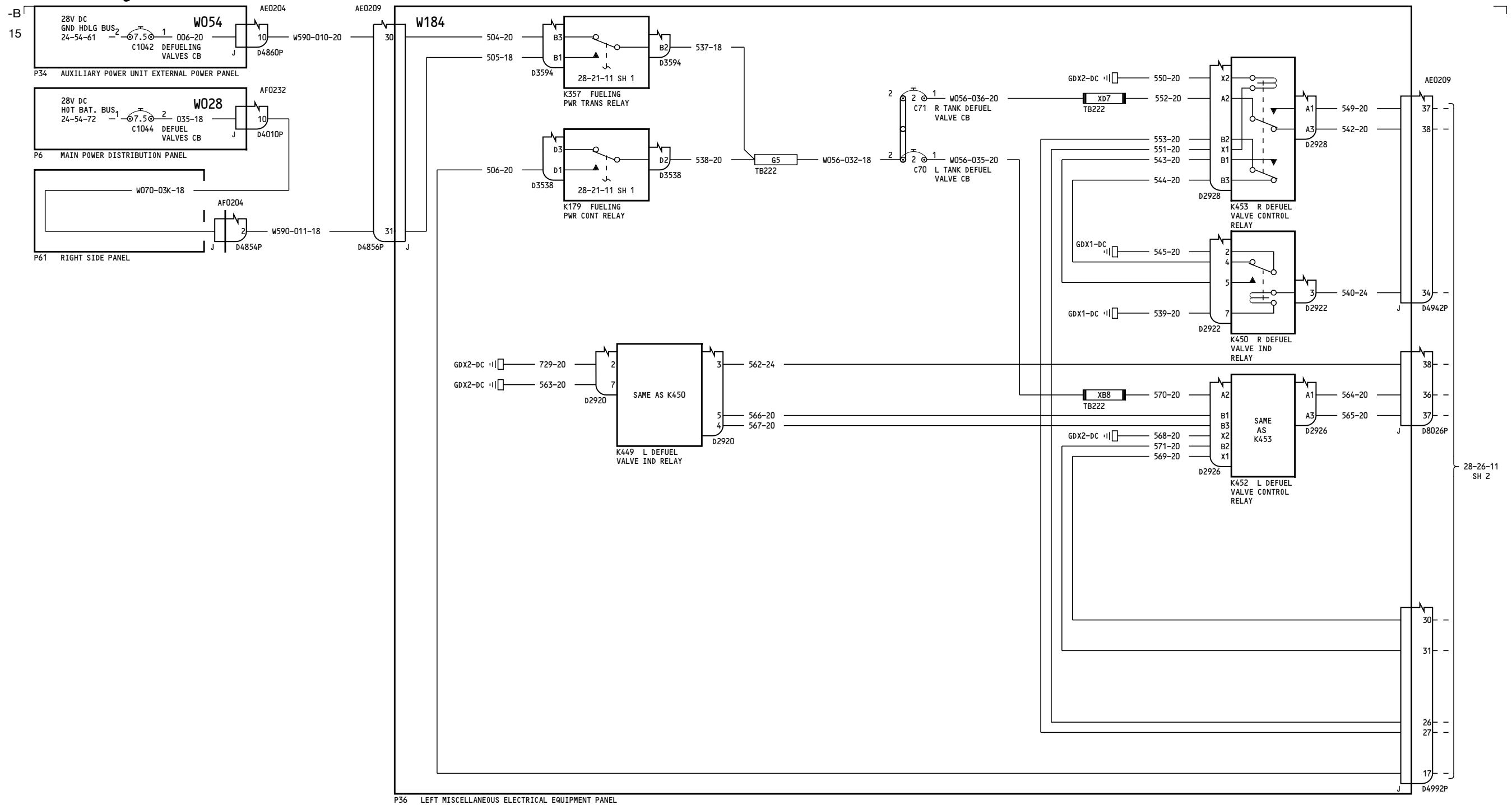

157, 167-199, 277-299

**DEFUELING VALVES**

**28-26-11**

Page 2  
Sheet 1  
Jan 21/2005

D280T132

**28-26-11**

Page 2  
Sheet 1  
Jan 21/2005

-B  
15

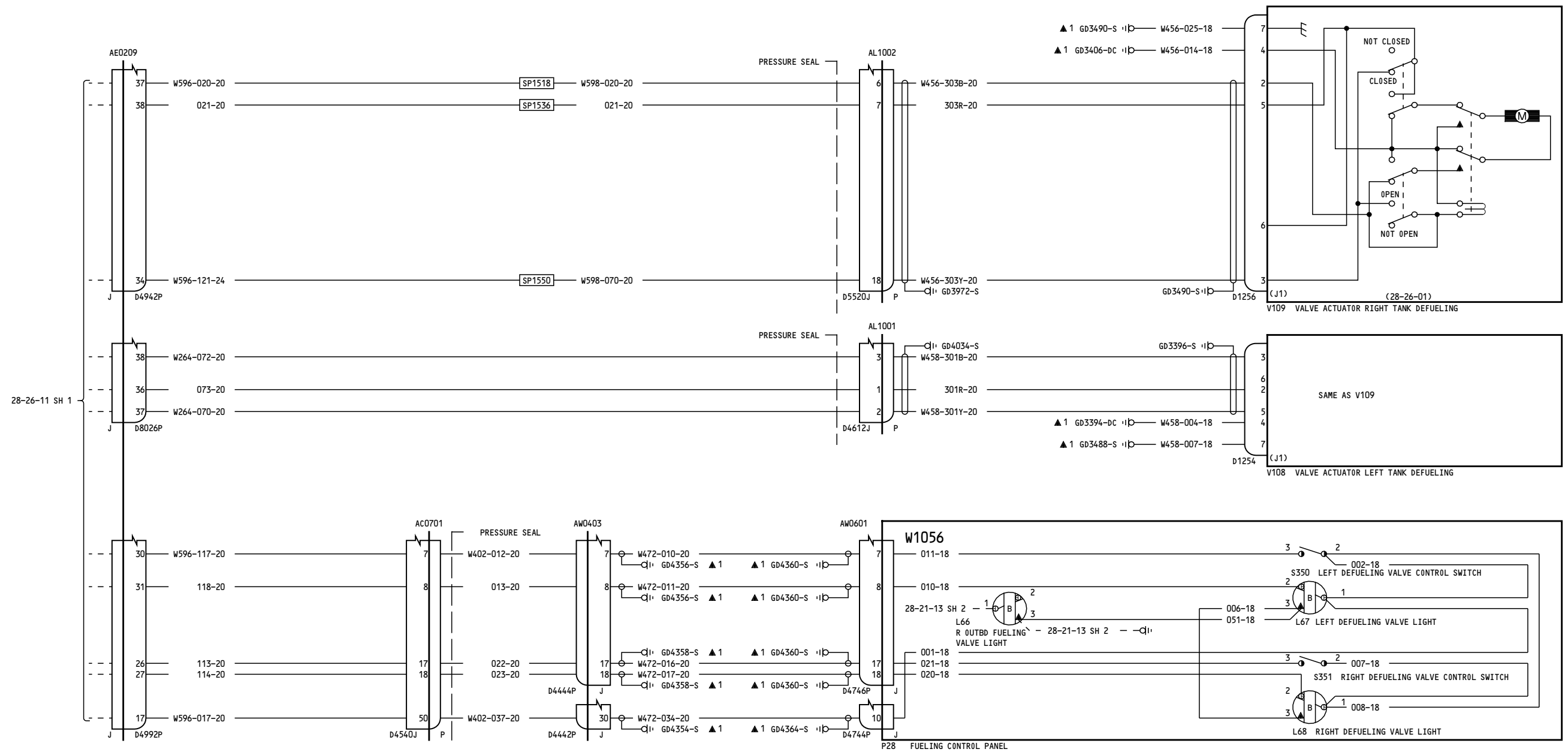

157, 167-199, 277-299

**DEFUELING VALVES**

**28-26-11**

Page 2  
Sheet 2  
Jan 21/2005

D280T132

**28-26-11**

Page 2  
Sheet 2  
Jan 21/2005

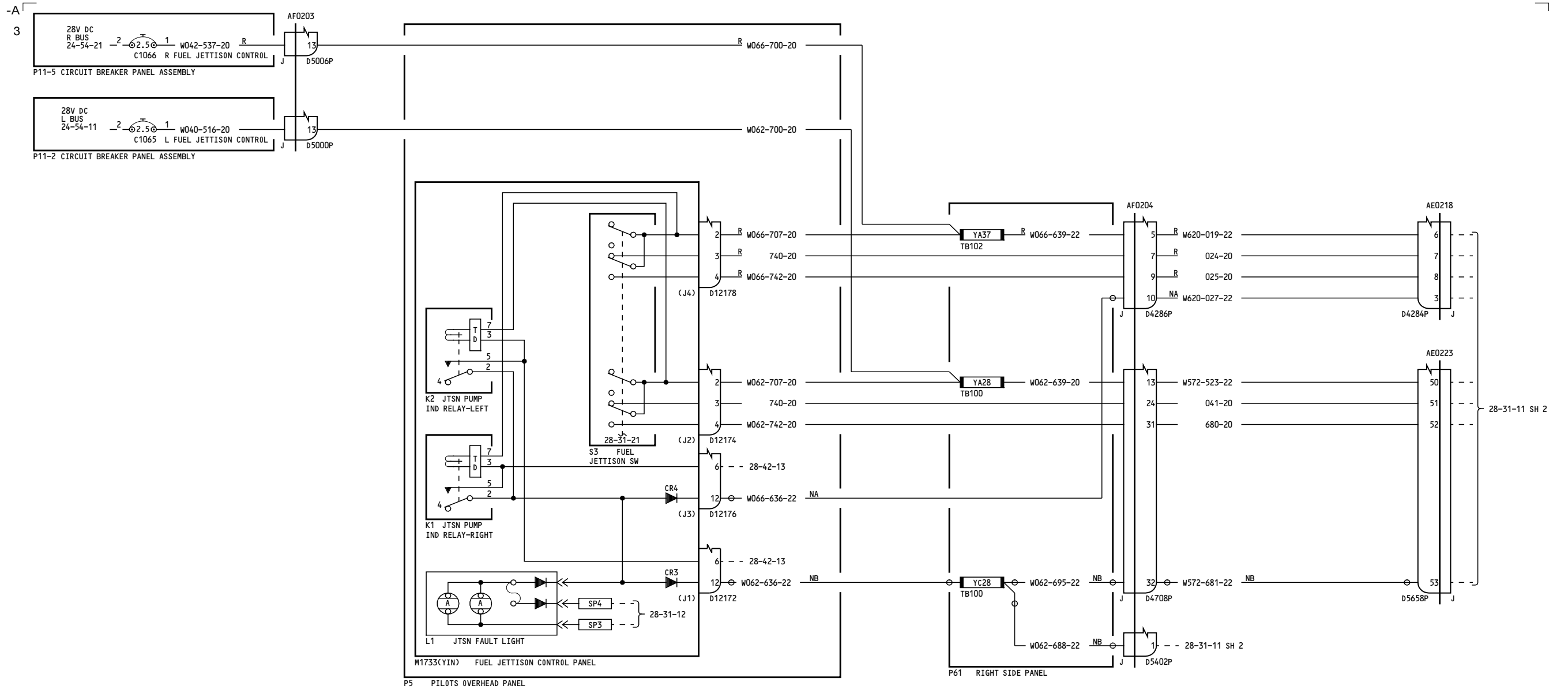

050

FUEL JETTISON TRANSFER VALVE CONTROL

28-31-11

Page 1  
Sheet 1  
Jan 21/2005

D280T132

28-31-11

Page 1  
Sheet 1  
Jan 21/2005

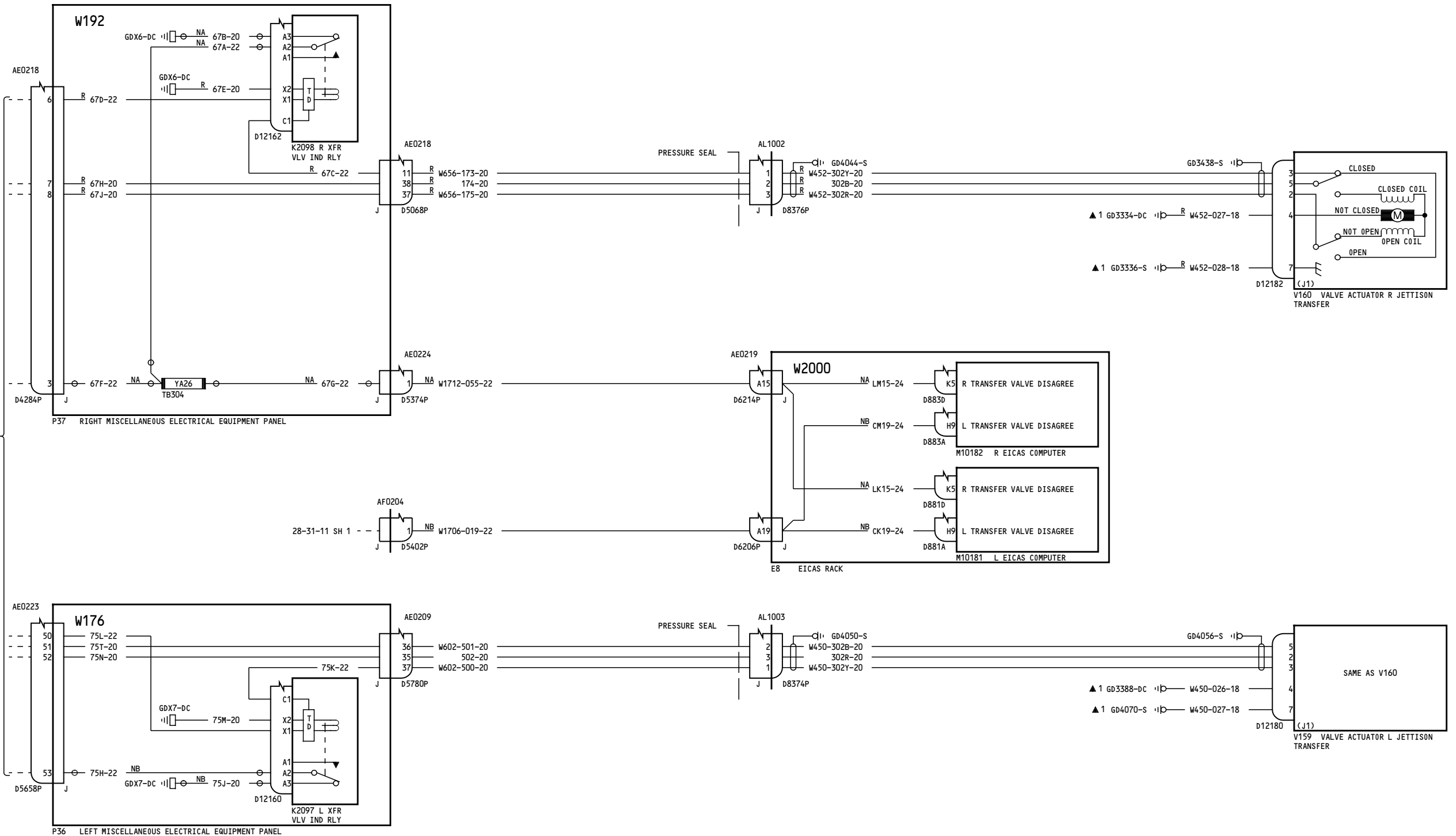

050

**FUEL JETTISON TRANSFER VALVE CONTROL**

D280T132

**28-31-11**

Page 1  
Sheet 2  
Jan 21/2005

**28-31-11**

Page 1  
Sheet 2  
Jan 21/2005



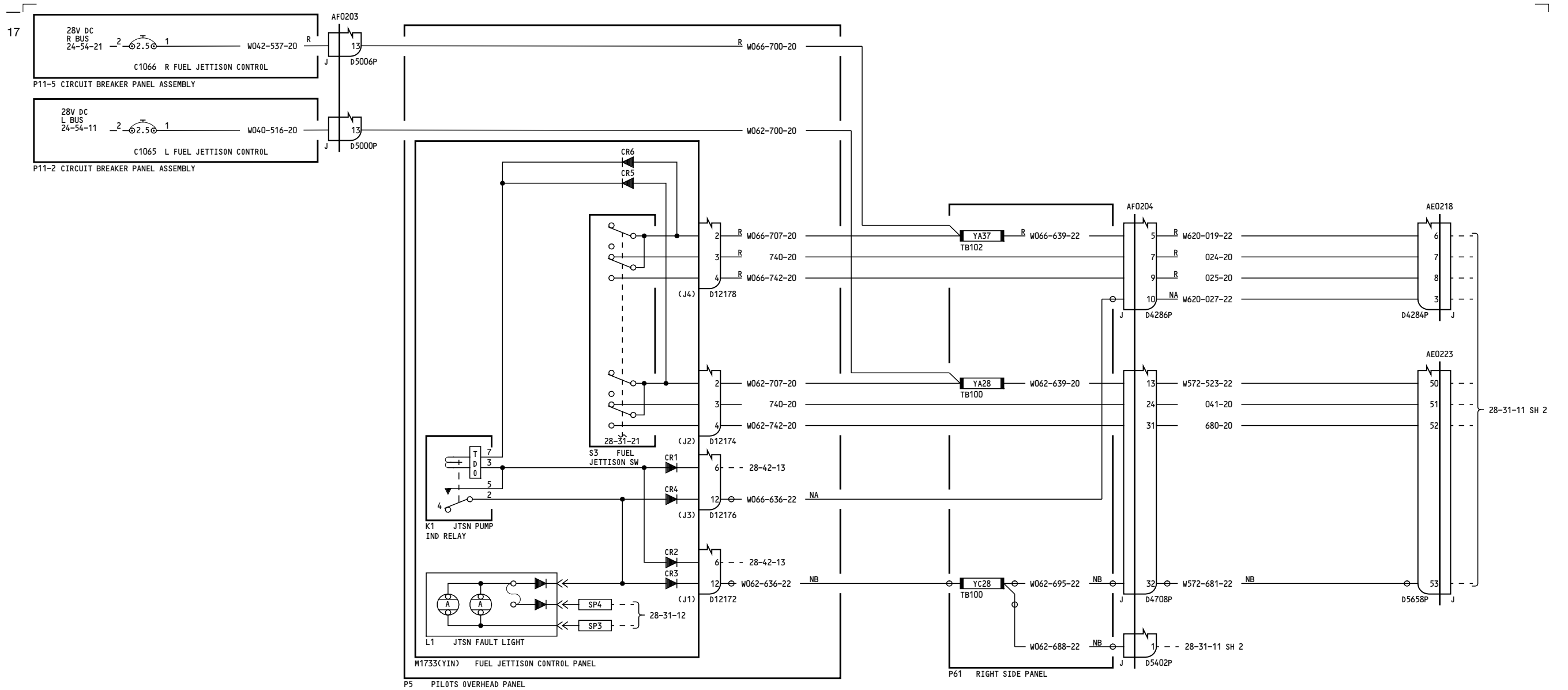

051

**FUEL JETTISON TRANSFER VALVE CONTROL**

**28-31-11**

Page 2.1  
Sheet 1  
Jan 21/2005

D280T132

Incorporates  
28-0030

**28-31-11**

Page 2.1  
Sheet 1  
Jan 21/2005

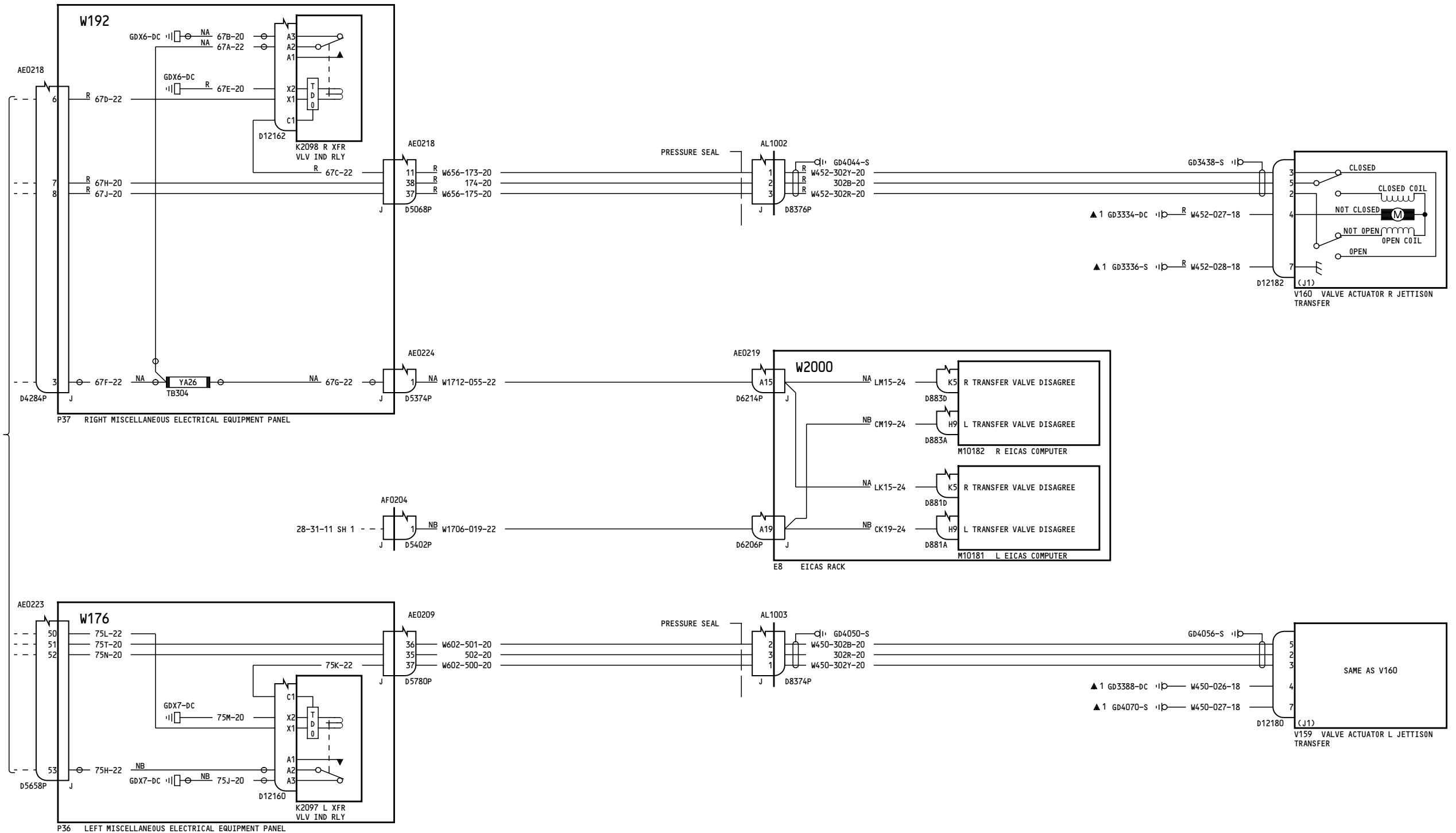

051

**FUEL JETTISON TRANSFER VALVE CONTROL**

D280T132

**28-31-11**

Page 2.1  
Sheet 2  
Jan 21/2005

Incorporates  
28-0030

**28-31-11**

Page 2.1  
Sheet 2  
Jan 21/2005

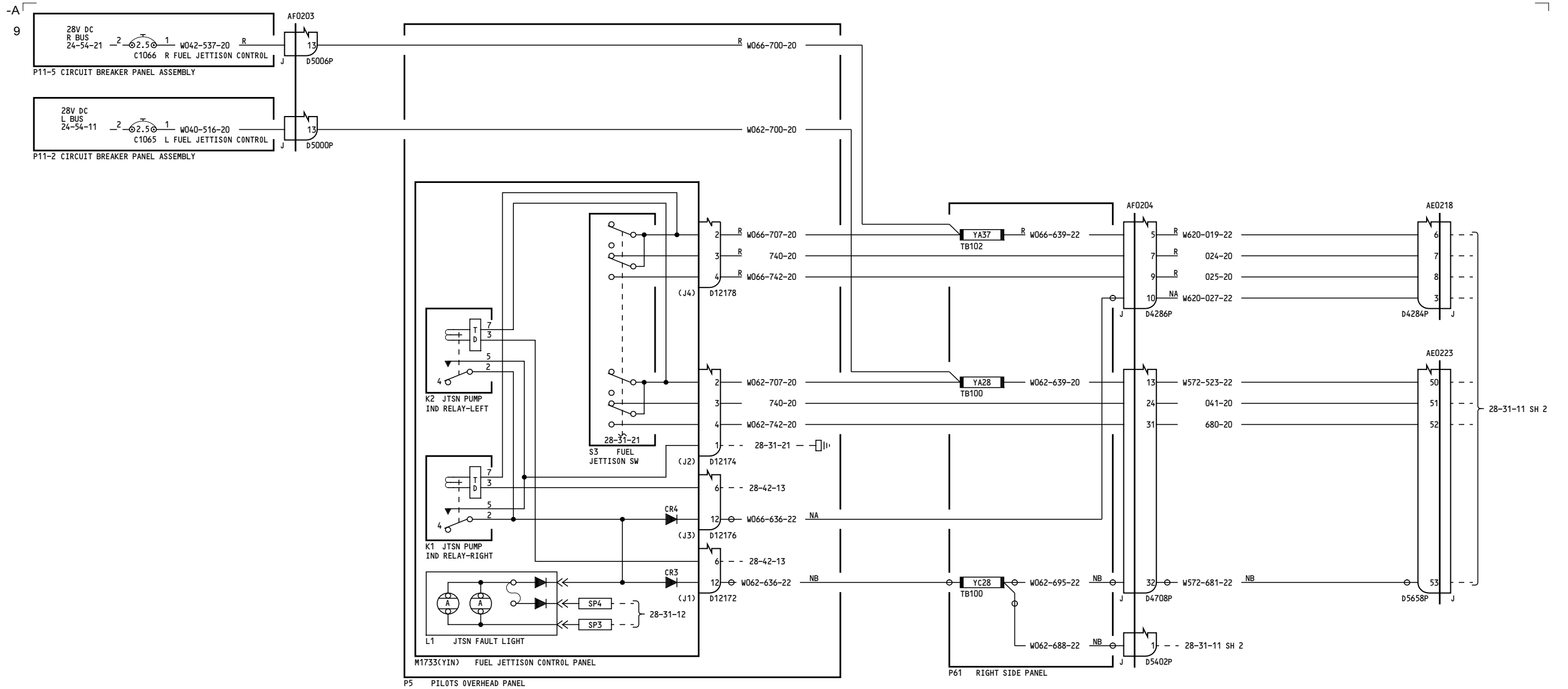

155-156, 165-166

**FUEL JETTISON TRANSFER VALVE CONTROL**

**28-31-11**

Page 3  
Sheet 1  
Jan 21/2005

D280T132

**28-31-11**

Page 3  
Sheet 1  
Jan 21/2005

-B  
9

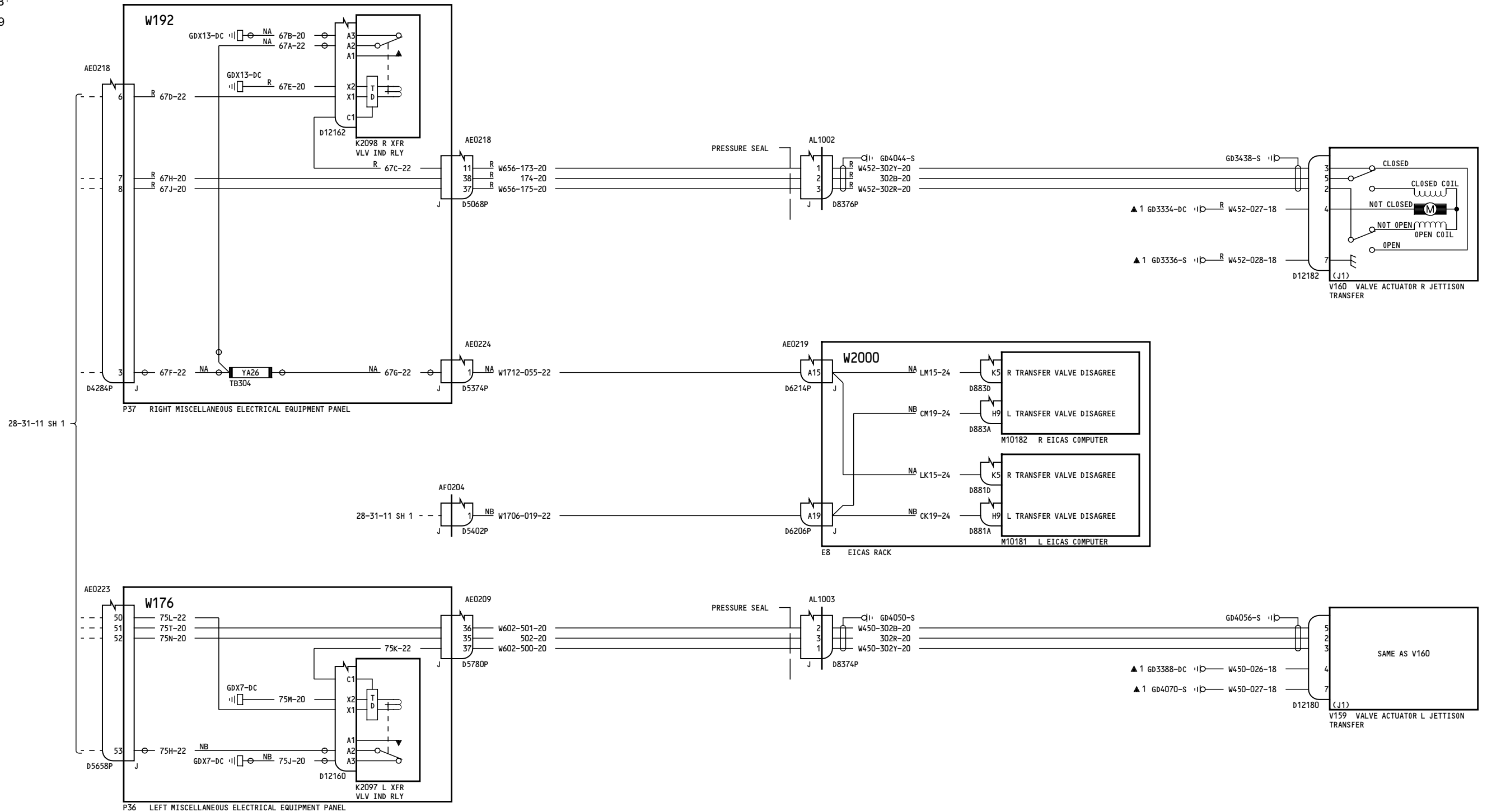

155-156, 165-166

**FUEL JETTISON TRANSFER VALVE CONTROL**

D280T132

**28-31-11**

Page 3  
Sheet 2  
Jan 21/2005

**28-31-11**

Page 3  
Sheet 2  
Jan 21/2005

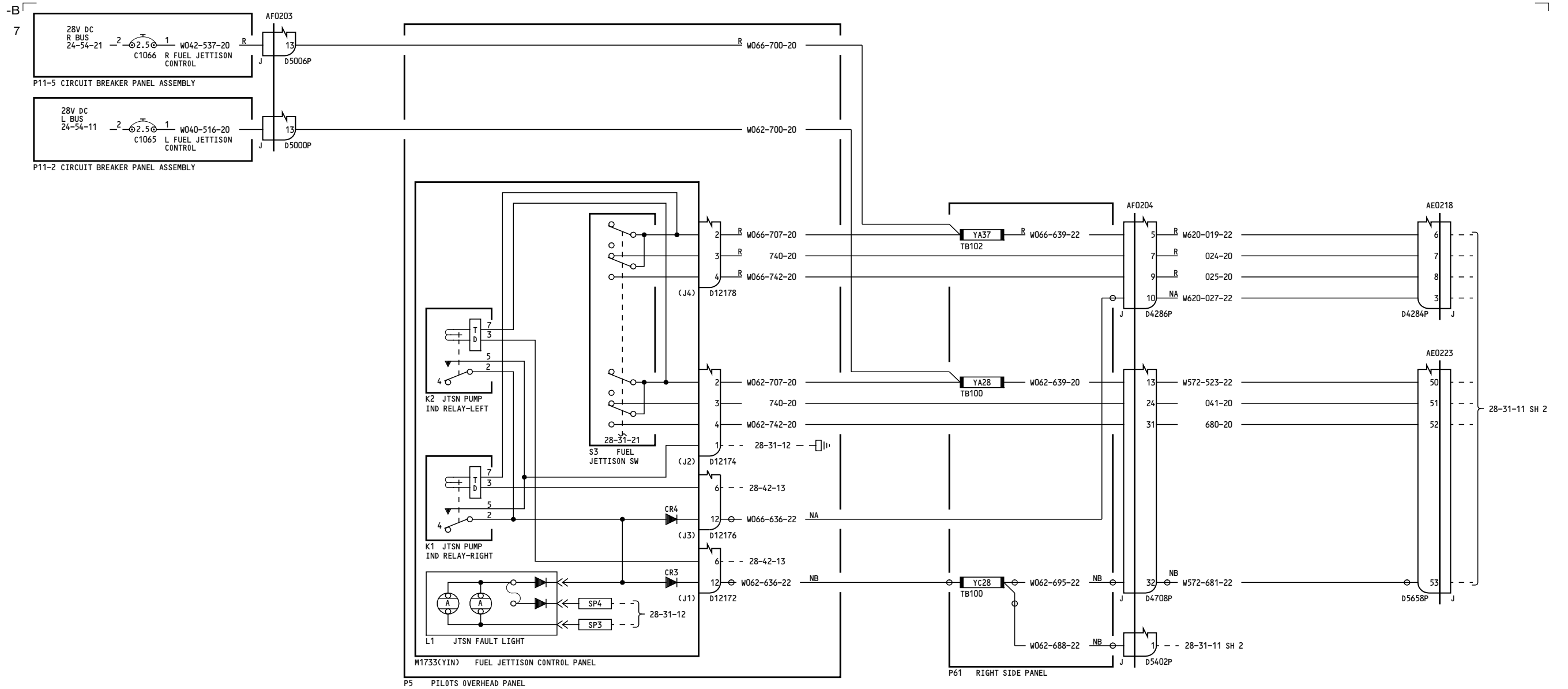

157, 167-199, 277-299

**FUEL JETTISON TRANSFER VALVE CONTROL**

**28-31-11**

Page 4  
Sheet 1  
Jan 21/2005

D280T132

**28-31-11**

Page 4  
Sheet 1  
Jan 21/2005

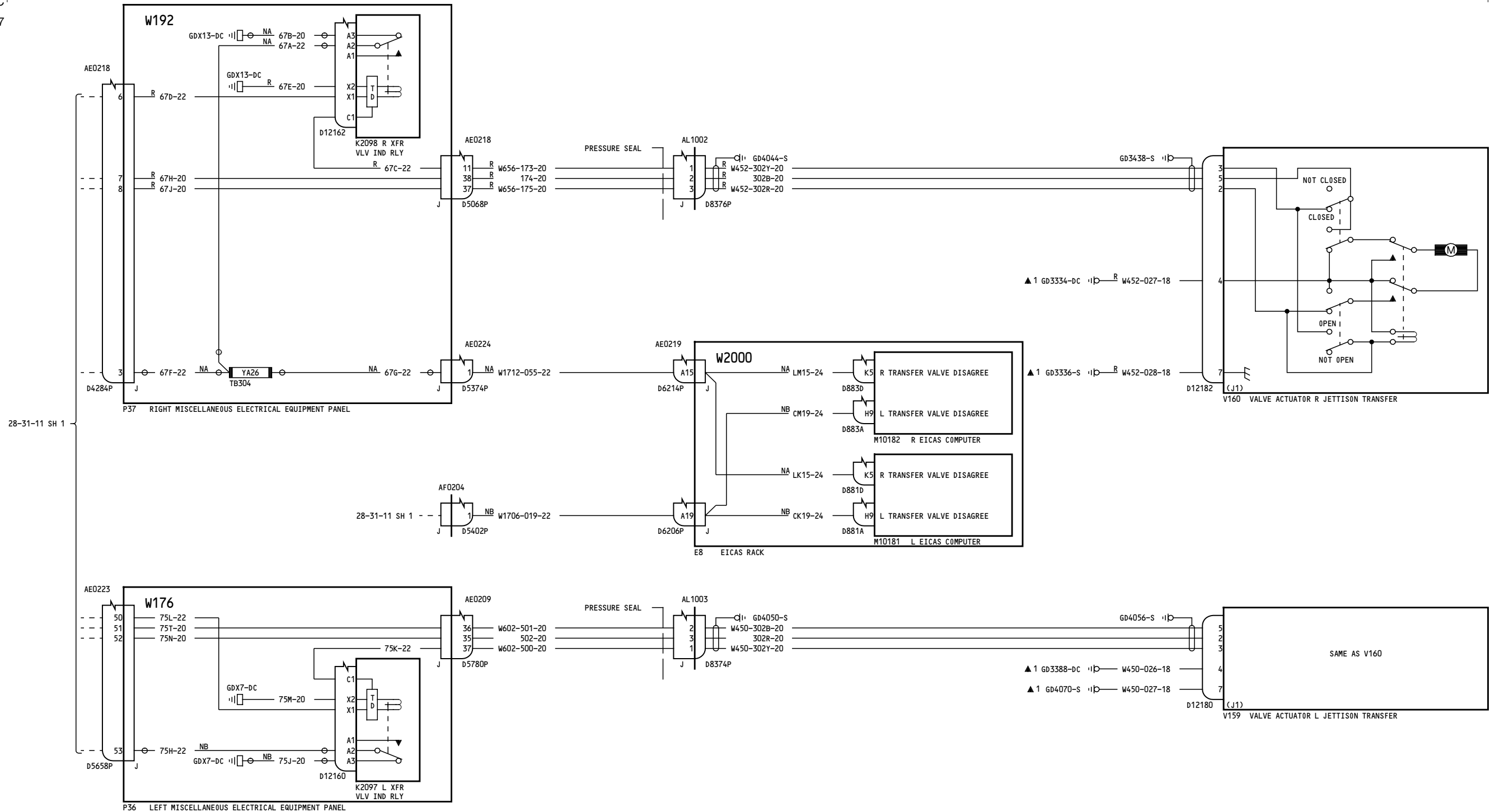

157, 167-199, 277-299

**FUEL JETTISON TRANSFER VALVE CONTROL**

D280T132

**28-31-11**

Page 4  
Sheet 2  
Jan 21/2005

**28-31-11**

Page 4  
Sheet 2  
Jan 21/2005

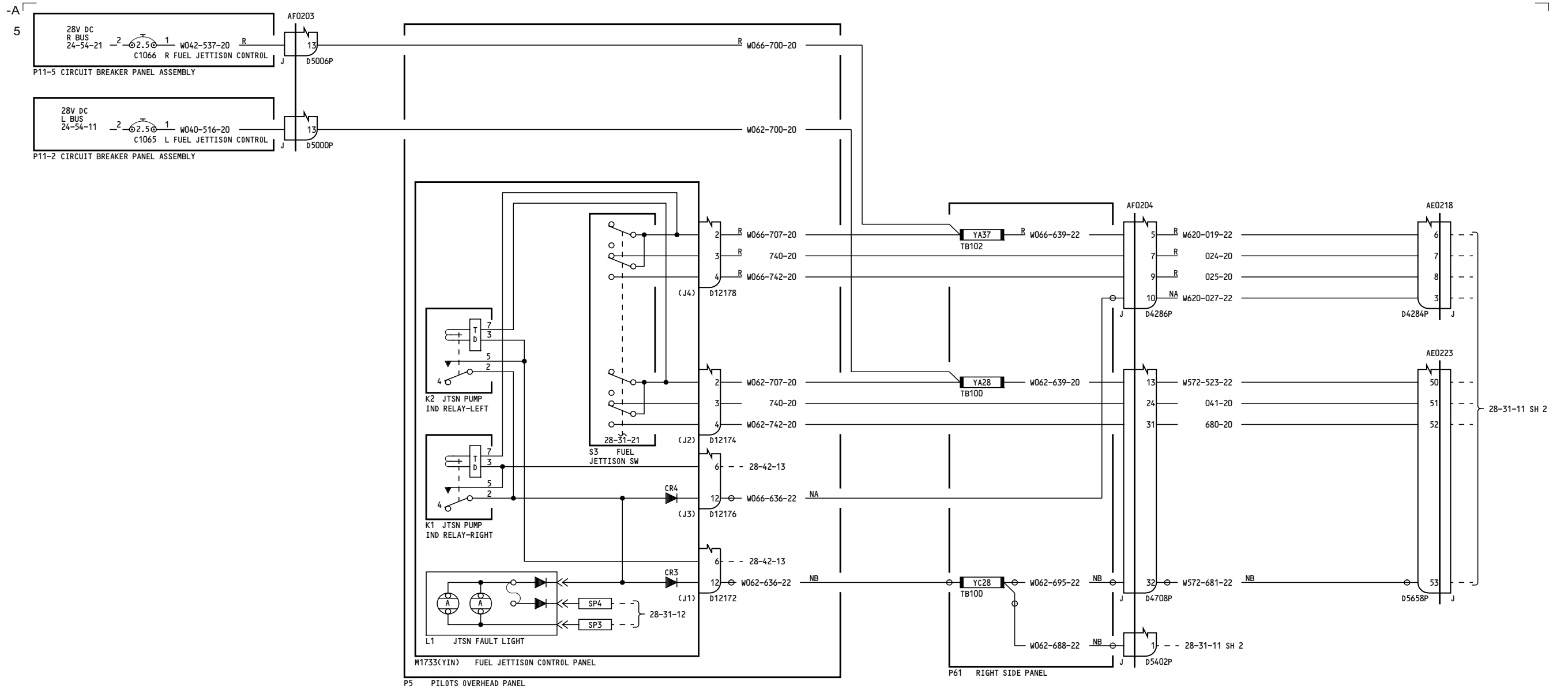

162-164

**FUEL JETTISON TRANSFER VALVE CONTROL**

**28-31-11**

Page 5  
Sheet 1  
Jan 21/2005

D280T132

**28-31-11**

Page 5  
Sheet 1  
Jan 21/2005

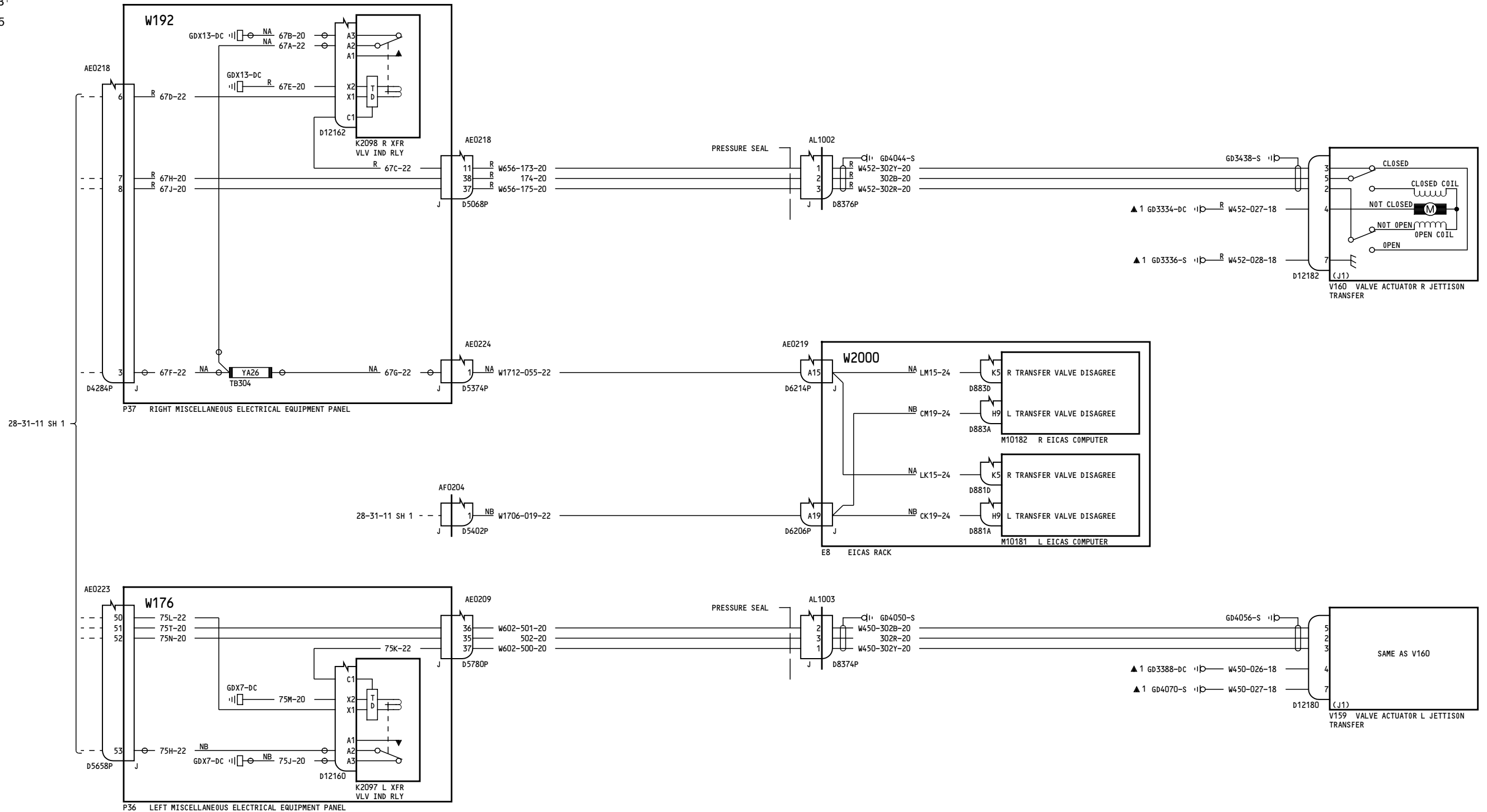

162-164

**FUEL JETTISON TRANSFER VALVE CONTROL**

D280T132

**28-31-11**

Page 5  
Sheet 2  
Jan 21/2005

**28-31-11**

Page 5  
Sheet 2  
Jan 21/2005



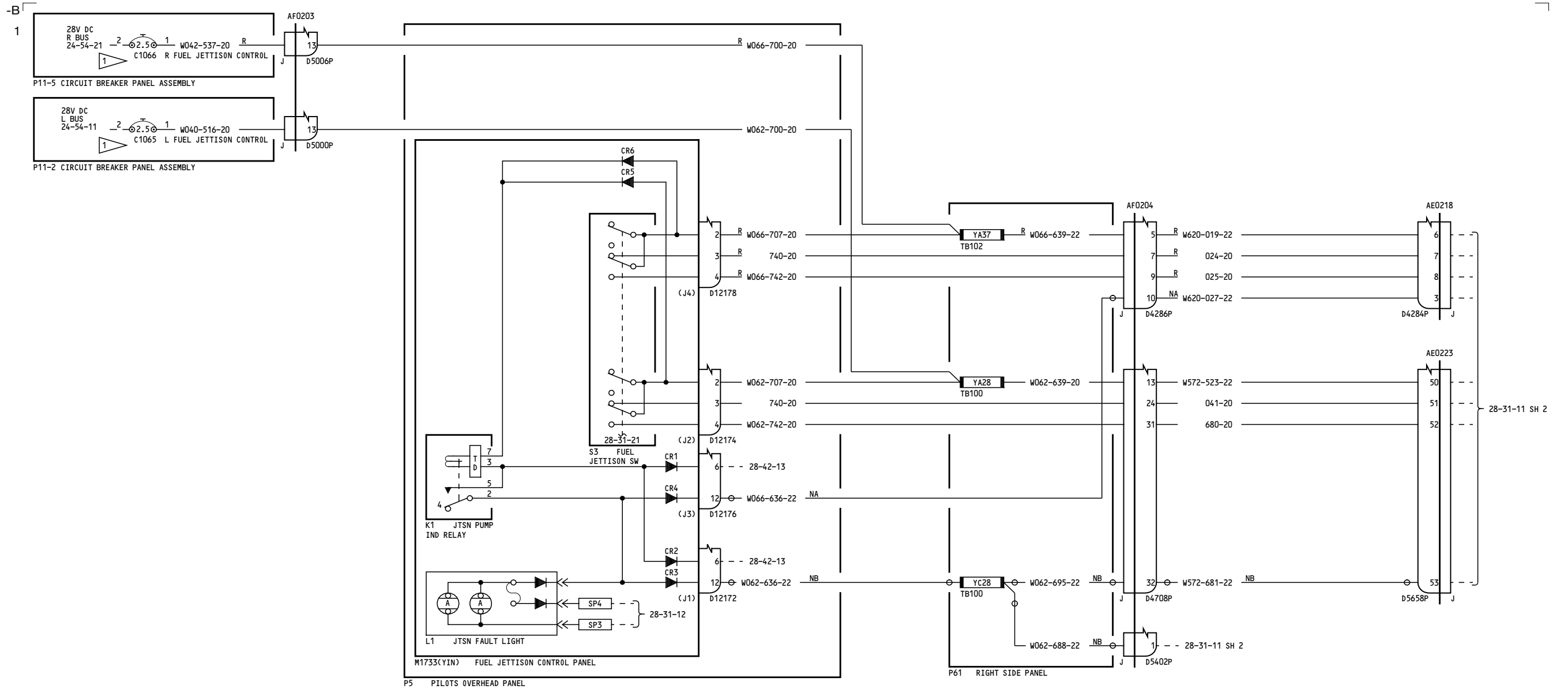

NOTES:  
 1 COLLARED AND LABELED INOP.

276

**FUEL JETTISON TRANSFER VALVE CONTROL**

**28-31-11**

Page 6  
 Sheet 1  
 Jan 21/2005

D280T132

**28-31-11**

Page 6  
 Sheet 1  
 Jan 21/2005

-B  
1

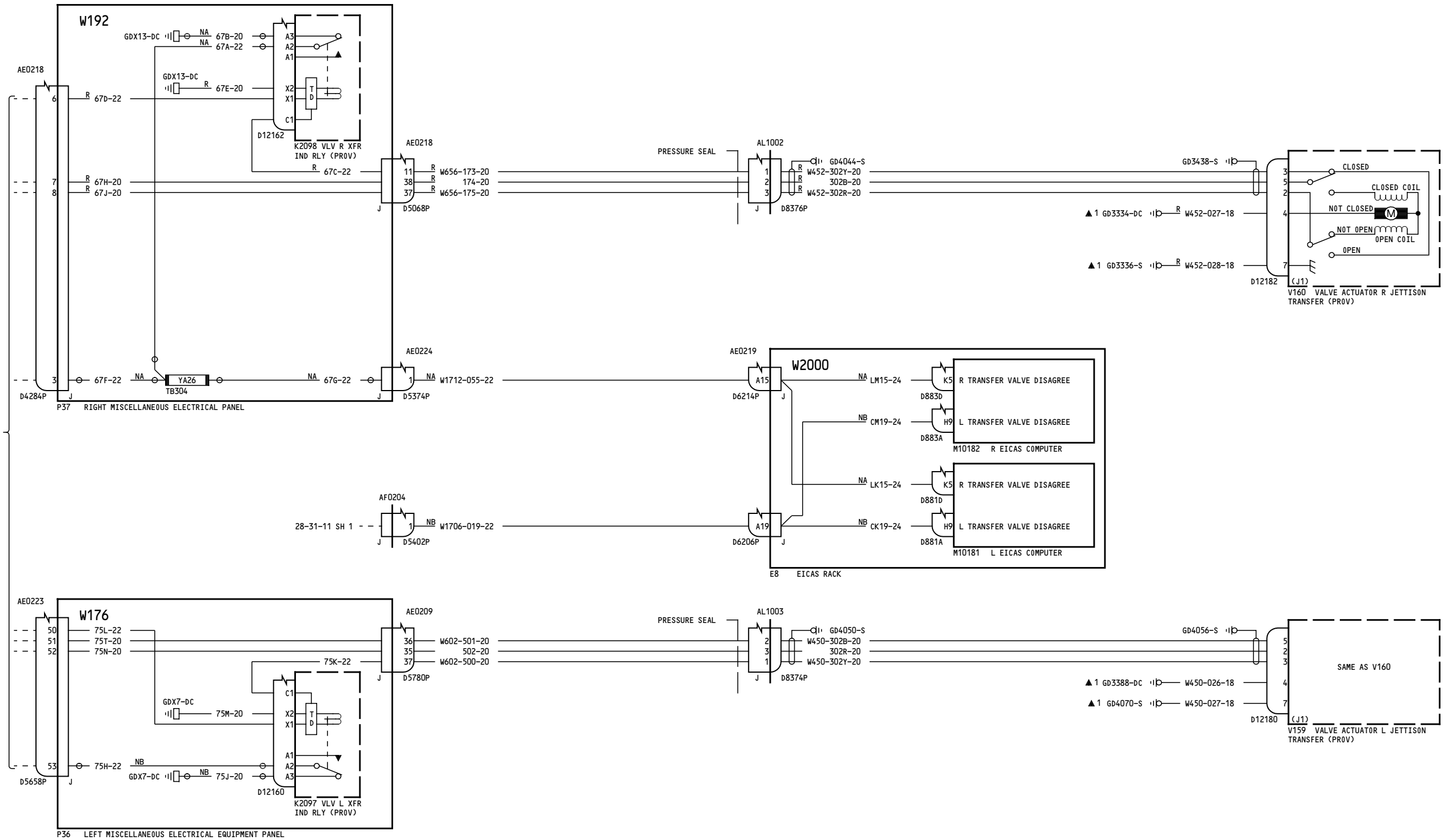

22

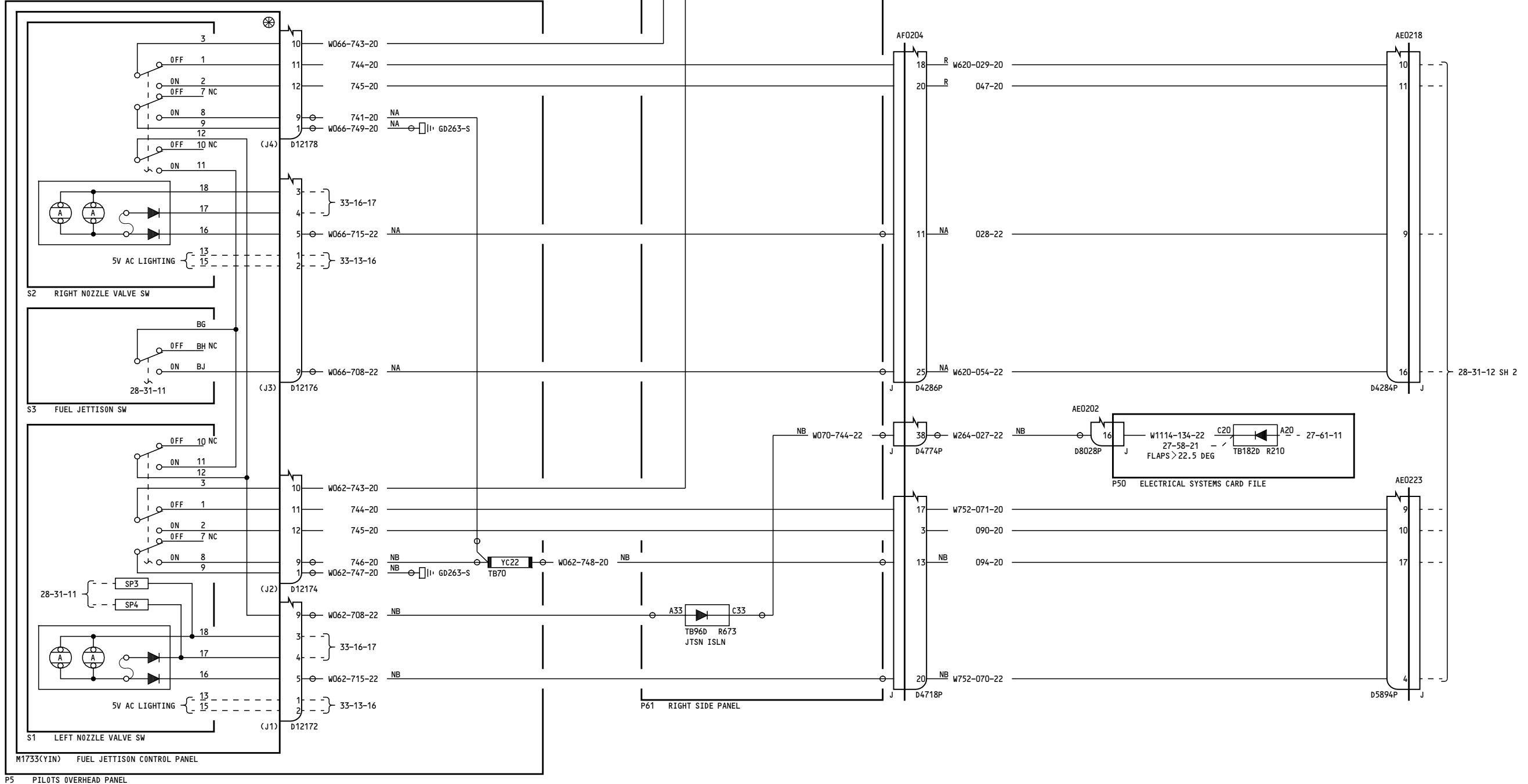
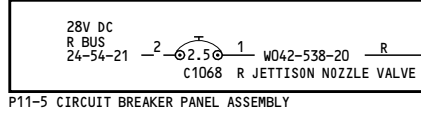
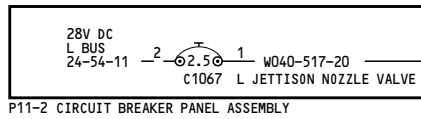

050

**FUEL JETTISON NOZZLE VALVE CONTROL**

**28-31-12**

Page 1  
Sheet 1  
Jan 21/2005

D280T132

**28-31-12**

Page 1  
Sheet 1  
Jan 21/2005

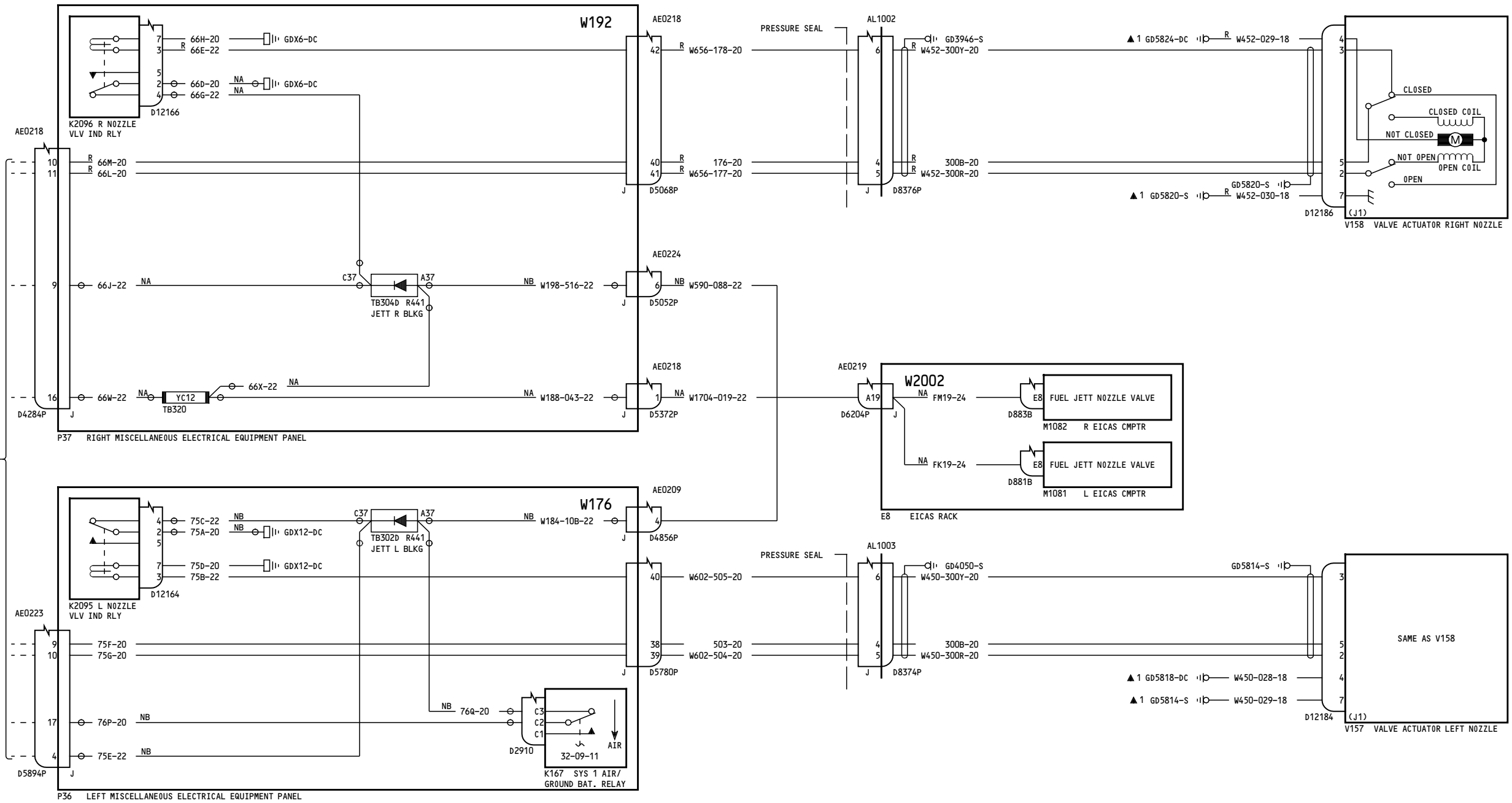

050

**FUEL JETTISON NOZZLE VALVE CONTROL**

**28-31-12**

Page 1  
Sheet 2  
Jan 21/2005

D280T132

**28-31-12**

Page 1  
Sheet 2  
Jan 21/2005

29

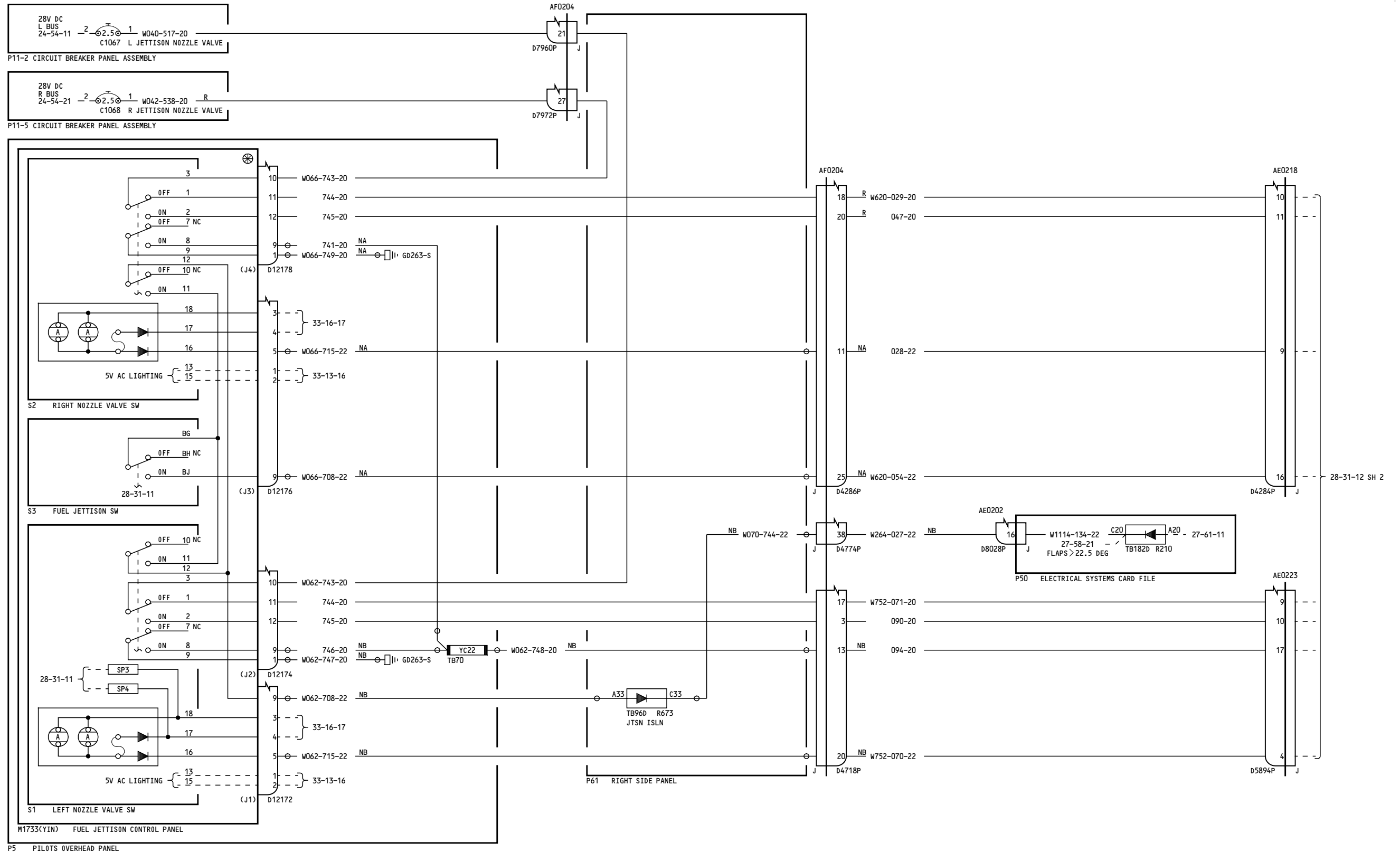

051

**FUEL JETTISON NOZZLE VALVE CONTROL**

D280T132

**28-31-12**

Page 2.1  
Sheet 1  
Jan 21/2005

Incorporates  
28-0030

**28-31-12**

Page 2.1  
Sheet 1  
Jan 21/2005

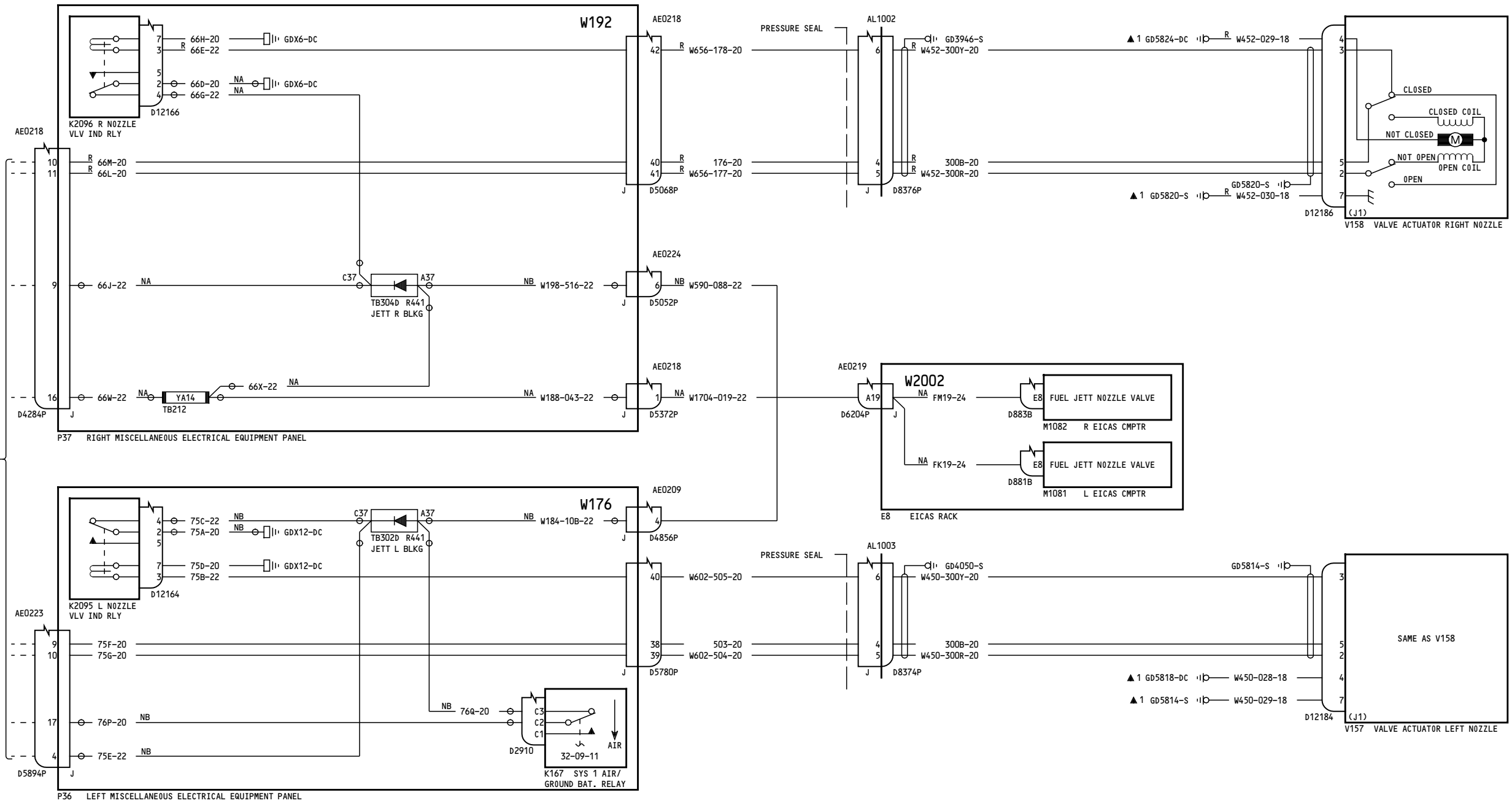

051

**FUEL JETTISON NOZZLE VALVE CONTROL**

**28-31-12**

Incorporates  
 28-0030

**28-31-12**

D280T132

Page 2.1  
 Sheet 2  
 Jan 21/2005

Page 2.1  
 Sheet 2  
 Jan 21/2005

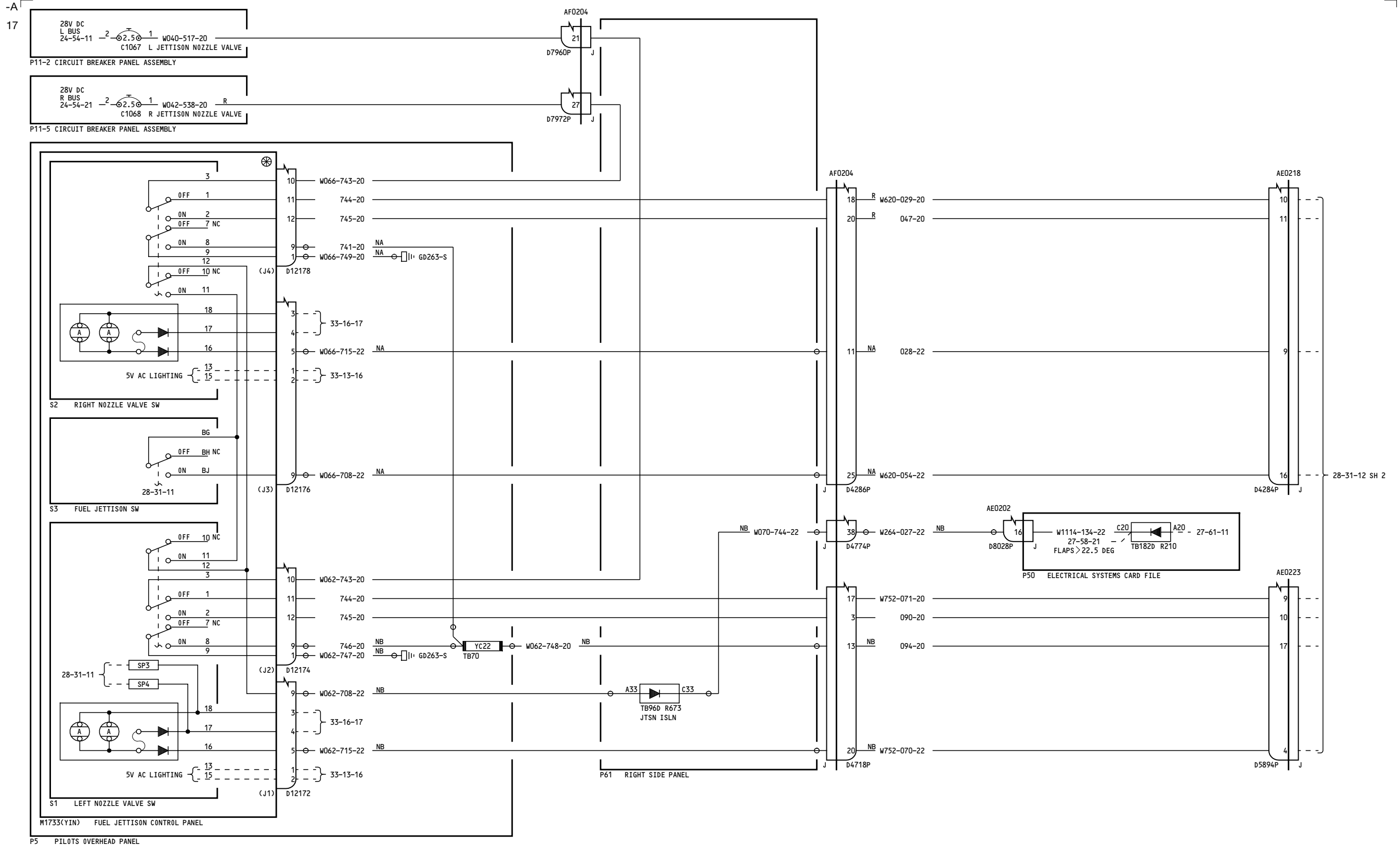

155-156, 162-166

**FUEL JETTISON NOZZLE VALVE CONTROL**

**28-31-12**

Page 3  
Sheet 1  
Jan 21/2005

D280T132

**28-31-12**

Page 3  
Sheet 1  
Jan 21/2005

-B  
17

28-31-12 SH 1

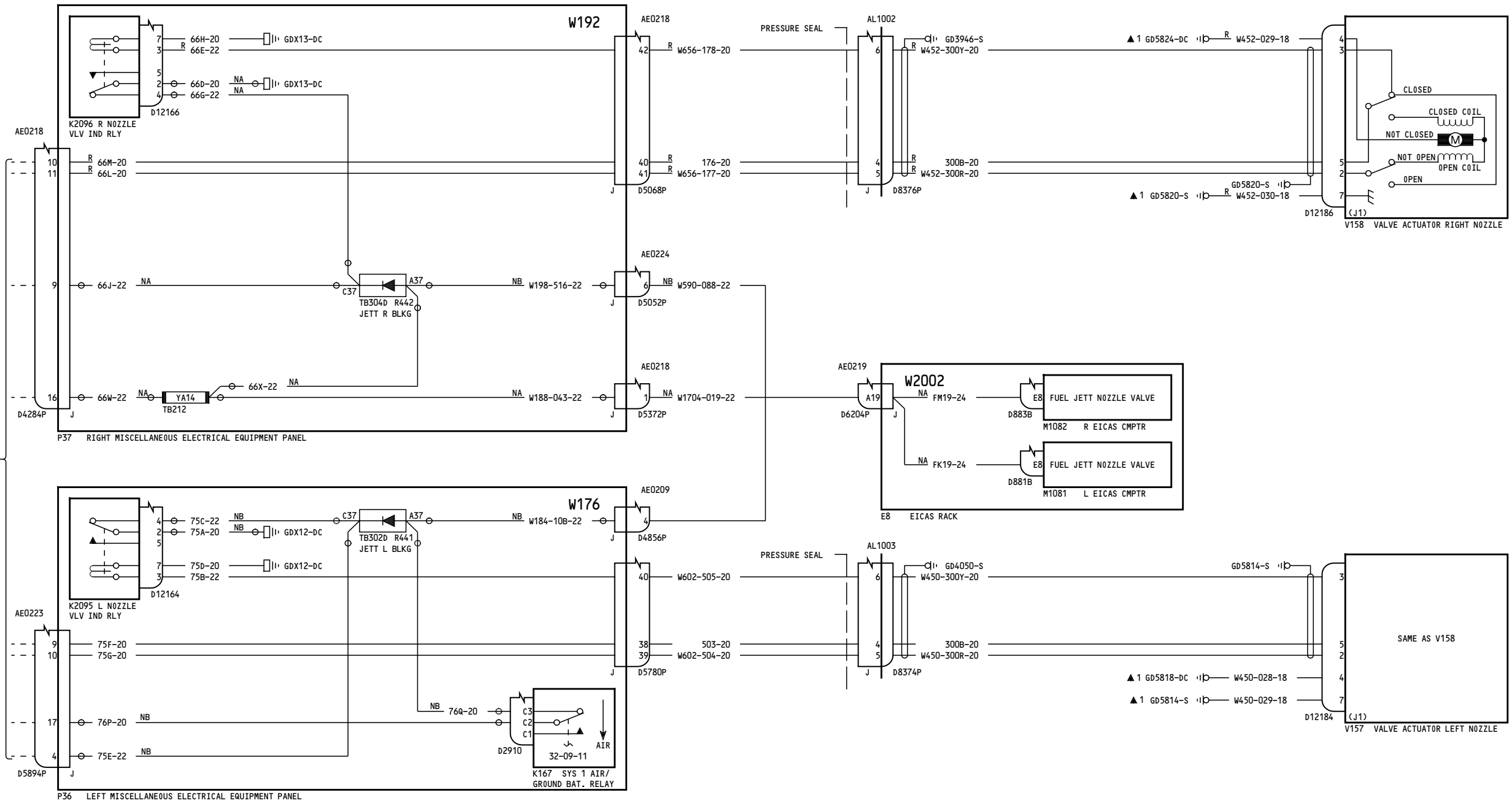

155-156, 162-166

**FUEL JETTISON NOZZLE VALVE CONTROL**

D280T132

**28-31-12**

Page 3  
Sheet 2  
Jan 21/2005

**28-31-12**

Page 3  
Sheet 2  
Jan 21/2005



32

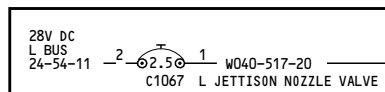

P11-2 CIRCUIT BREAKER PNL ASSY

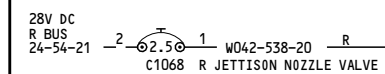

P11-5 CIRCUIT BREAKER PNL ASSY

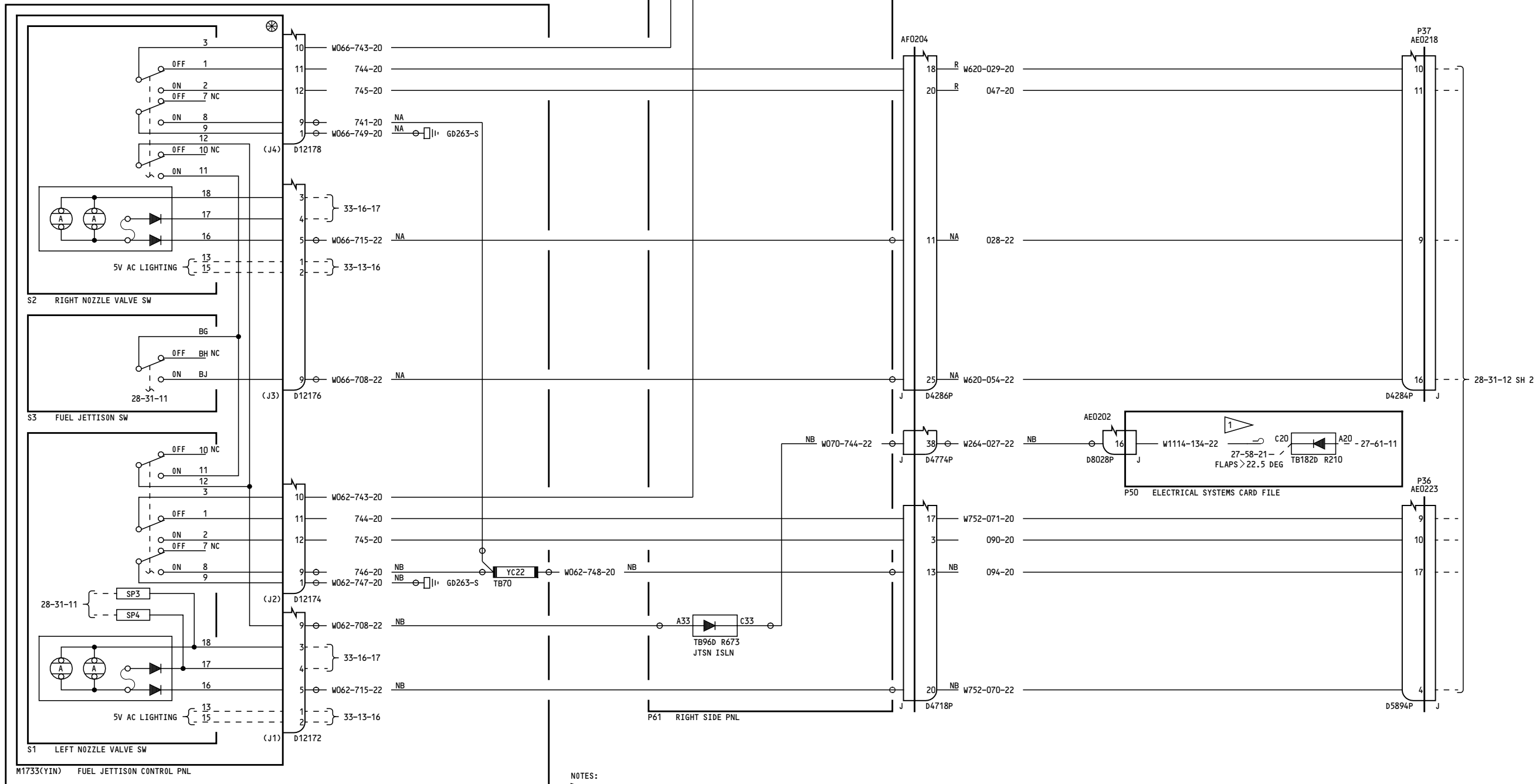

NOTES:  
1 CAP & STOW NEAR TB182D

155-156, 165-166

**FUEL JETTISON NOZZLE VALVE CONTROL**

**28-31-12**

Incorporates  
28-0038 R02

**28-31-12**

D280T132

Page 3.1  
Sheet 1  
Jan 21/2005

Page 3.1  
Sheet 1  
Jan 21/2005

36

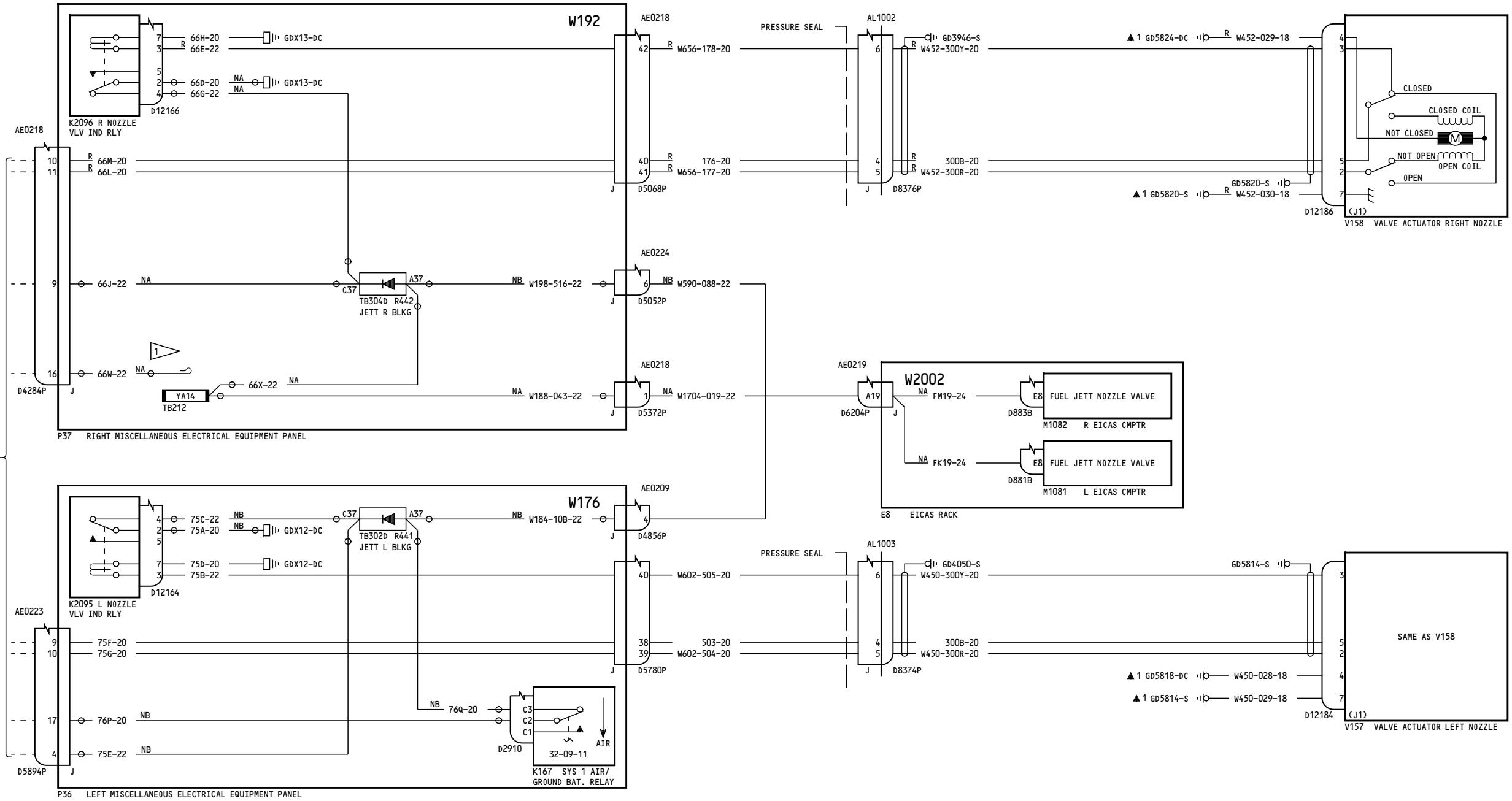

NOTES:  
1 CAP & STOW NEAR TB212Y

155-156, 165-166

**FUEL JETTISON NOZZLE VALVE CONTROL**

D280T132

**28-31-12**

Page 3.1  
Sheet 2  
Jan 21/2005

Incorporates  
28-0038 R02

**28-31-12**

Page 3.1  
Sheet 2  
Jan 21/2005

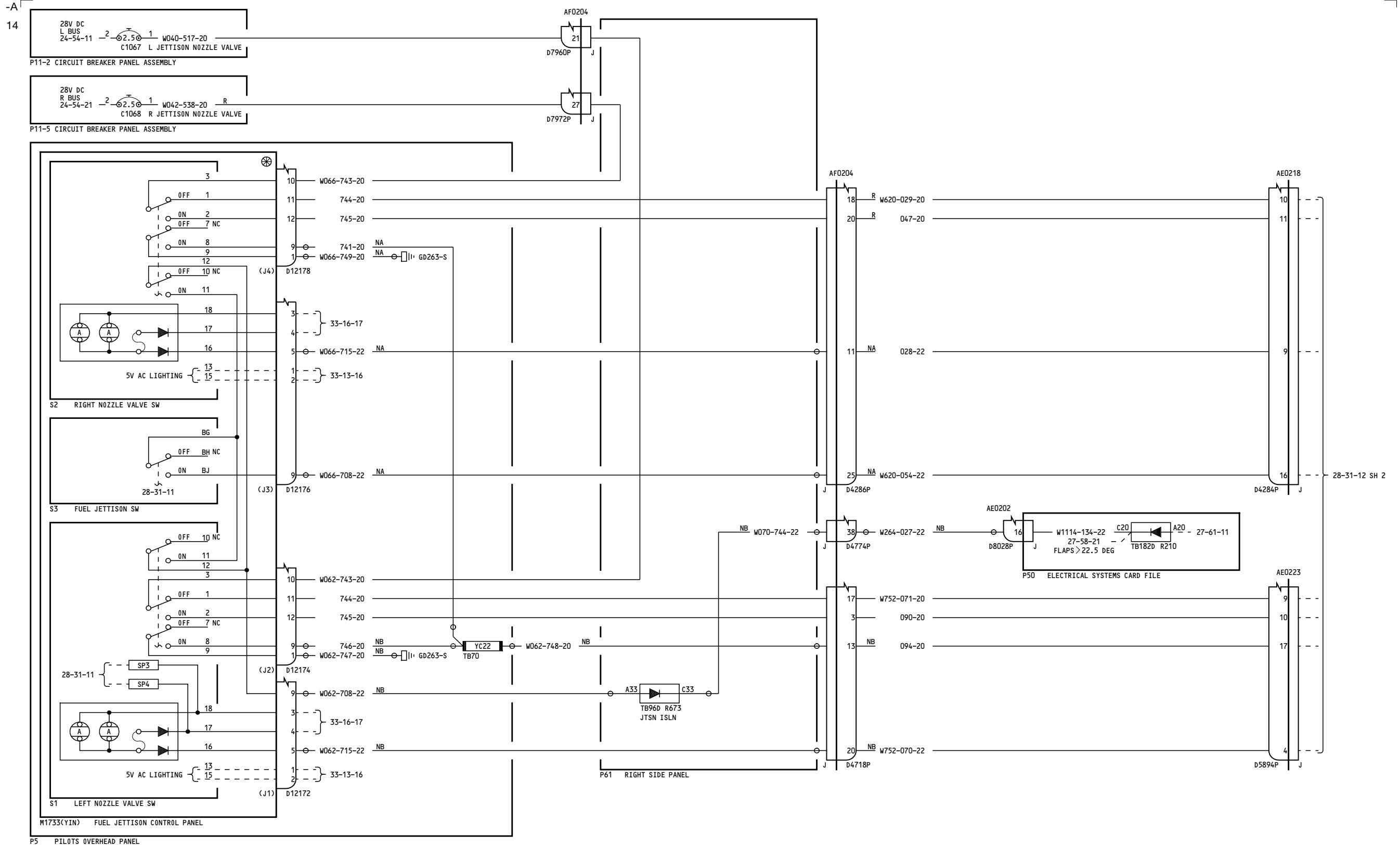

157, 167-199, 277-299

**FUEL JETTISON NOZZLE VALVE CONTROL**

**28-31-12**

Page 4  
Sheet 1  
Jan 21/2005

D280T132

**28-31-12**

Page 4  
Sheet 1  
Jan 21/2005

-B  
14

28-31-12 SH 1

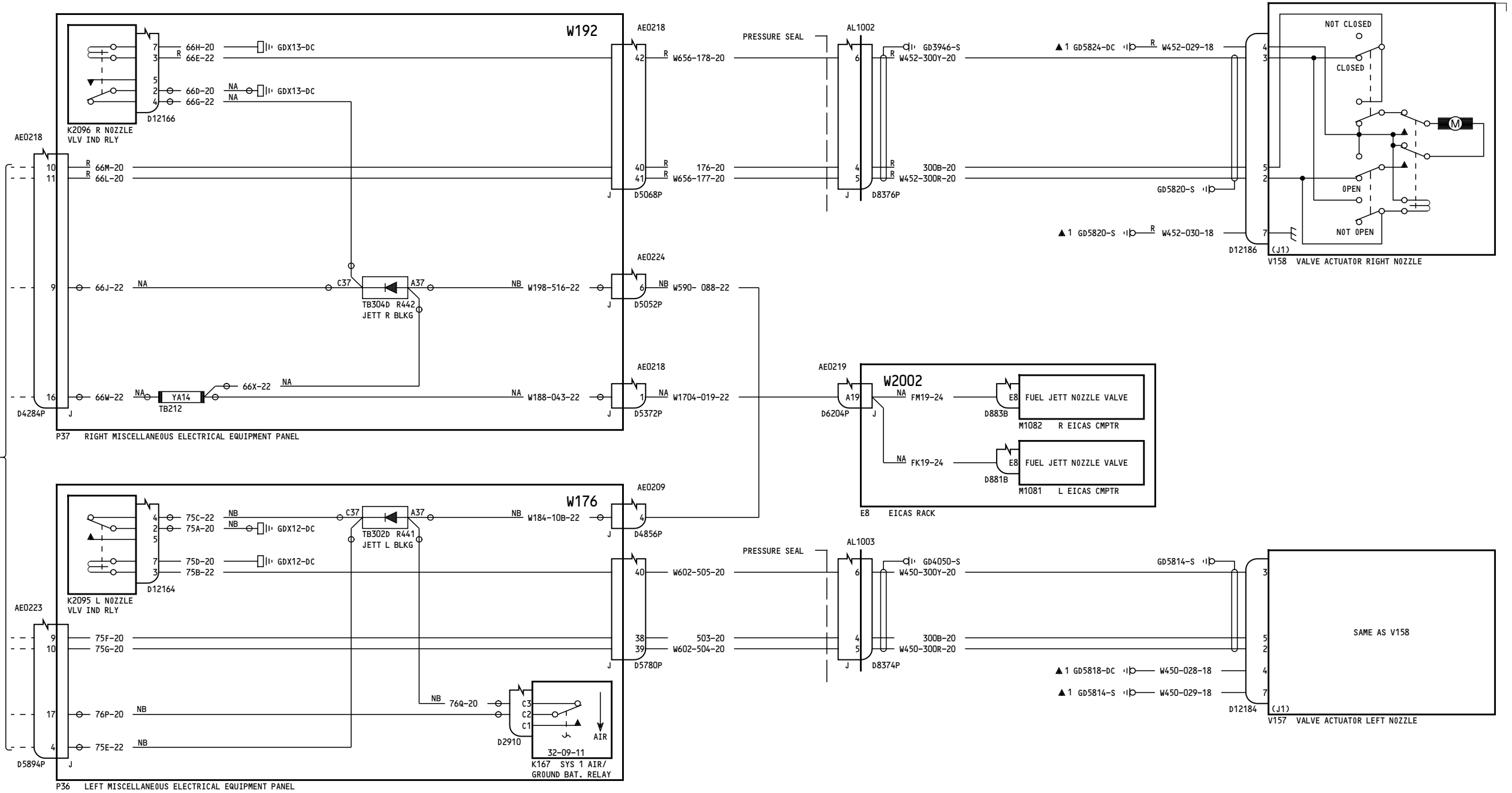

157, 167-199, 277-299

**FUEL JETTISON NOZZLE VALVE CONTROL**

**28-31-12**

Page 4  
Sheet 2  
Jan 21/2005

D280T132

**28-31-12**

Page 4  
Sheet 2  
Jan 21/2005

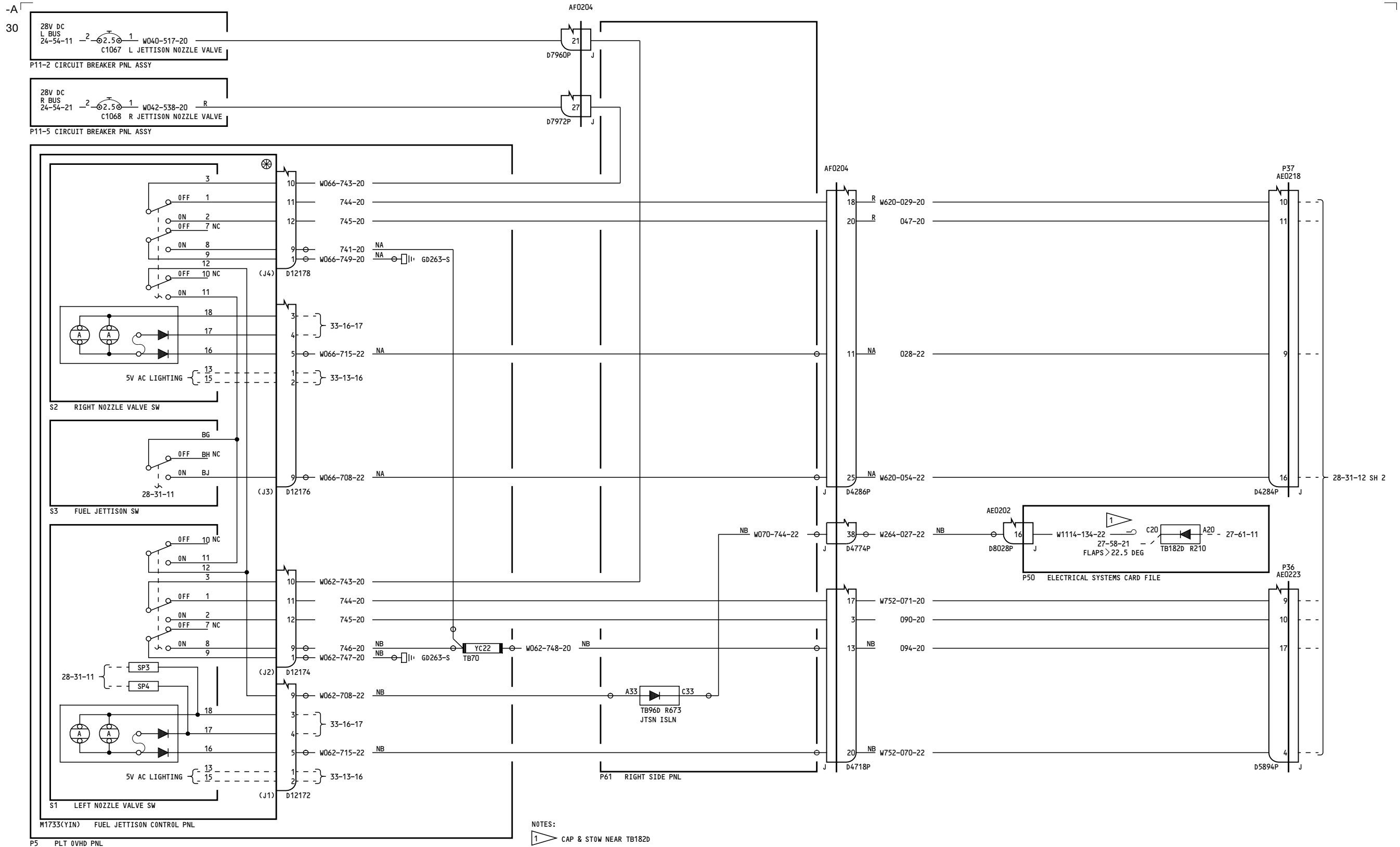

157, 167, 277-280

FUEL JETTISON NOZZLE VALVE CONTROL

D280T132

28-31-12

Page 4.1  
Sheet 1  
Jan 21/2005

Incorporates  
28-0038 R02

28-31-12

Page 4.1  
Sheet 1  
Jan 21/2005

-A  
34

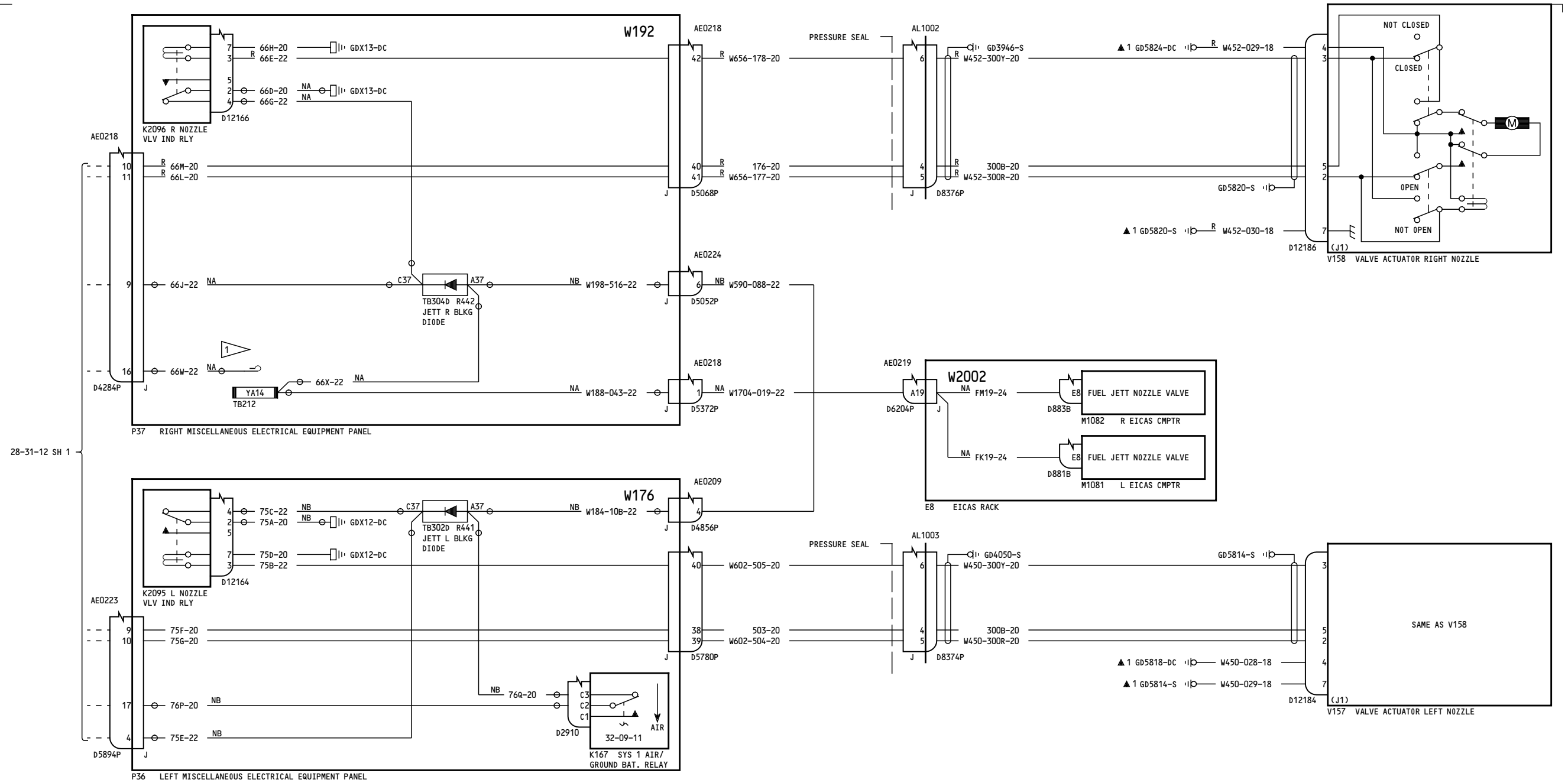

NOTES:  
1 CAP & STOW NEAR TB212Y

157, 167, 277-280

**FUEL JETTISON NOZZLE VALVE CONTROL**

D280T132

**28-31-12**

Page 4.1  
Sheet 2  
Jan 21/2005

Incorporates  
28-0038 R02

**28-31-12**

Page 4.1  
Sheet 2  
Jan 21/2005

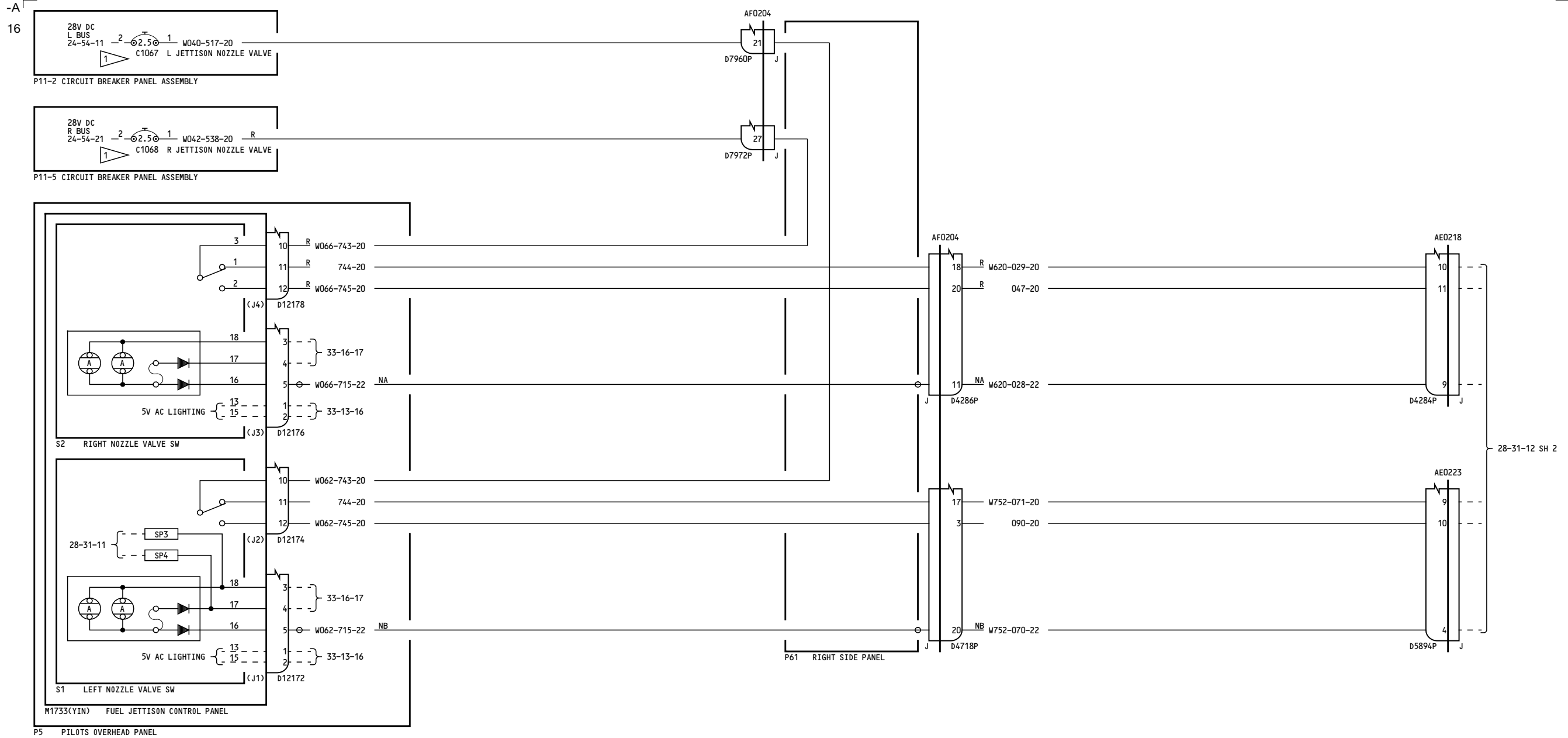

NOTES:  
 1 COLLARED AND LABELED INOP

276

**FUEL JETTISON NOZZLE VALVE CONTROL**

**28-31-12**

Page 5  
 Sheet 1  
 Jan 21/2005

D280T132

**28-31-12**

Page 5  
 Sheet 1  
 Jan 21/2005

-B  
16

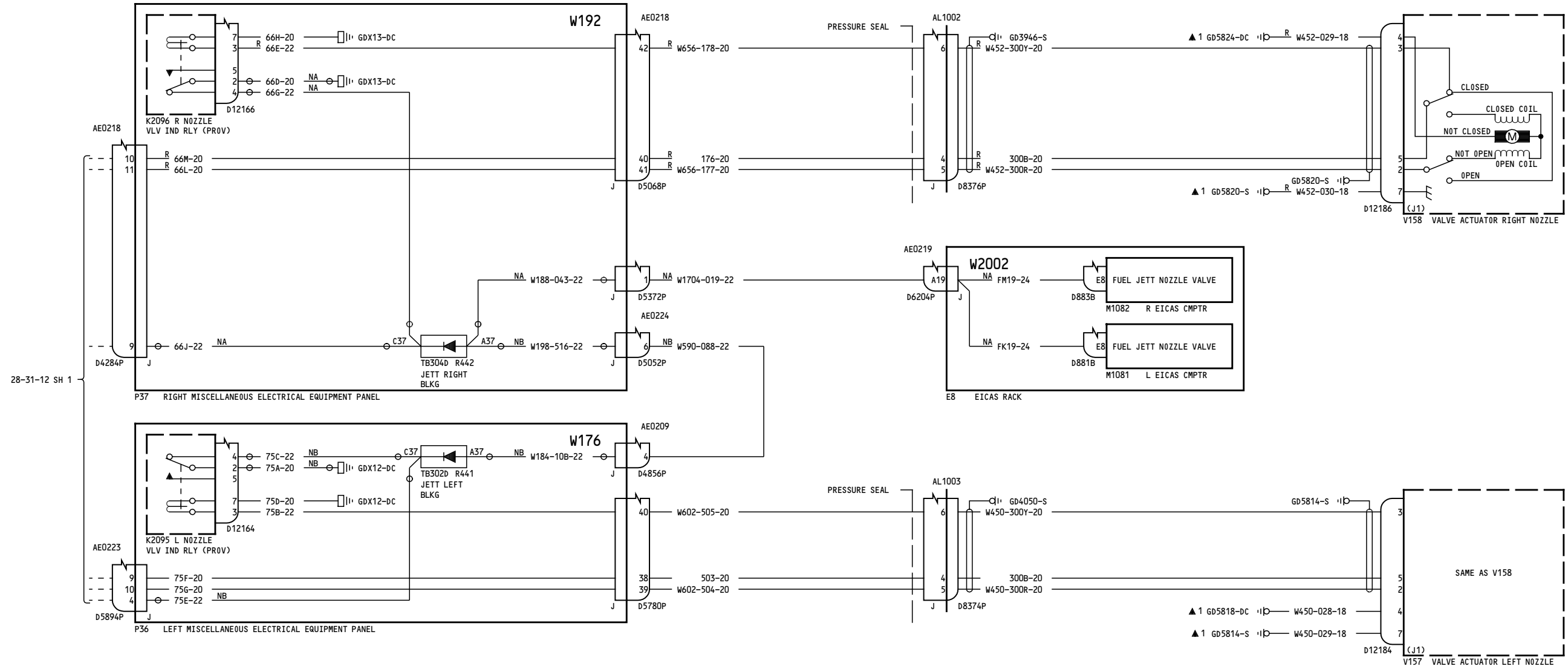

276

**FUEL JETTISON NOZZLE VALVE CONTROL**

**28-31-12**

Page 5  
Sheet 2  
Jan 21/2005

D280T132

**28-31-12**

Page 5  
Sheet 2  
Jan 21/2005



-A  
1

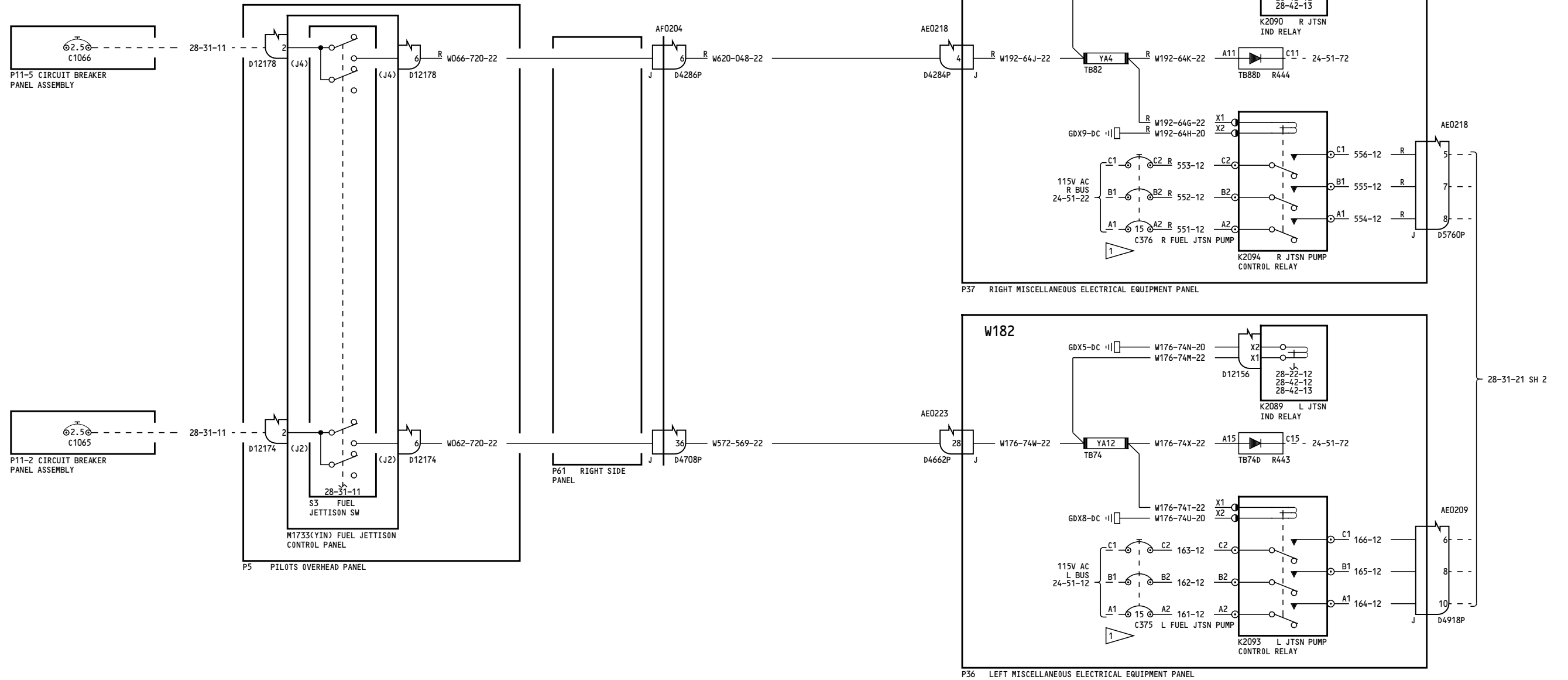

NOTES:  
1 COLLARED AND LABELED INOP

050-099, 162-164, 276	<b>FUEL JETTISON PUMPS</b>
	D280T132

**28-31-21**  
Page 1  
Sheet 1  
Jan 21/2005

**28-31-21**  
Page 1  
Sheet 1  
Jan 21/2005

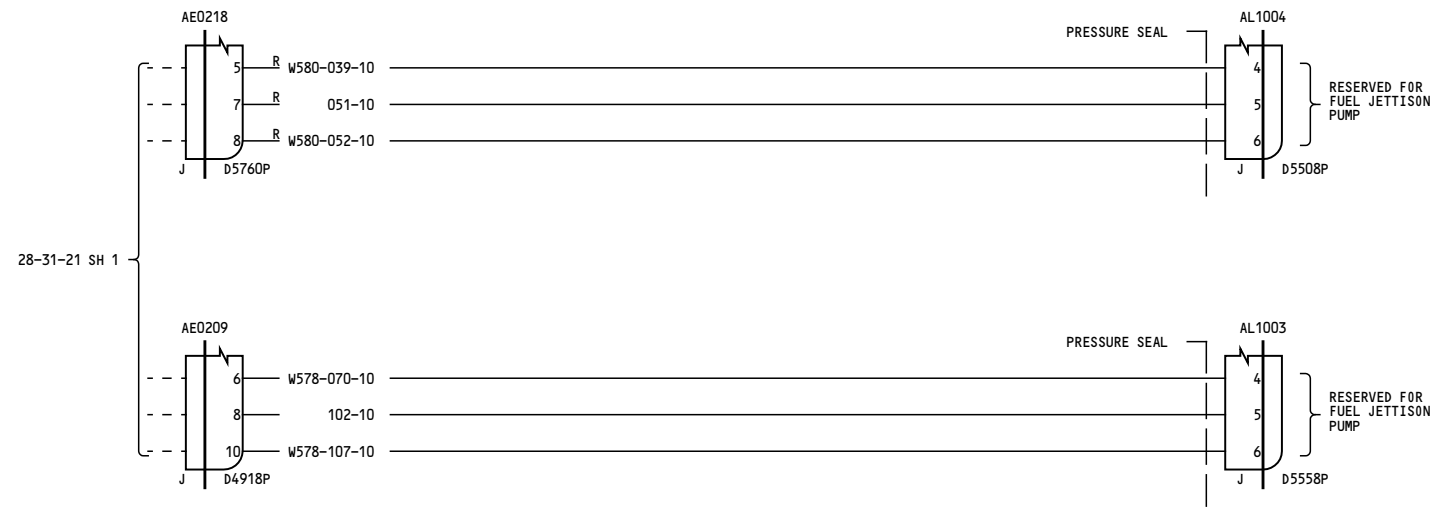

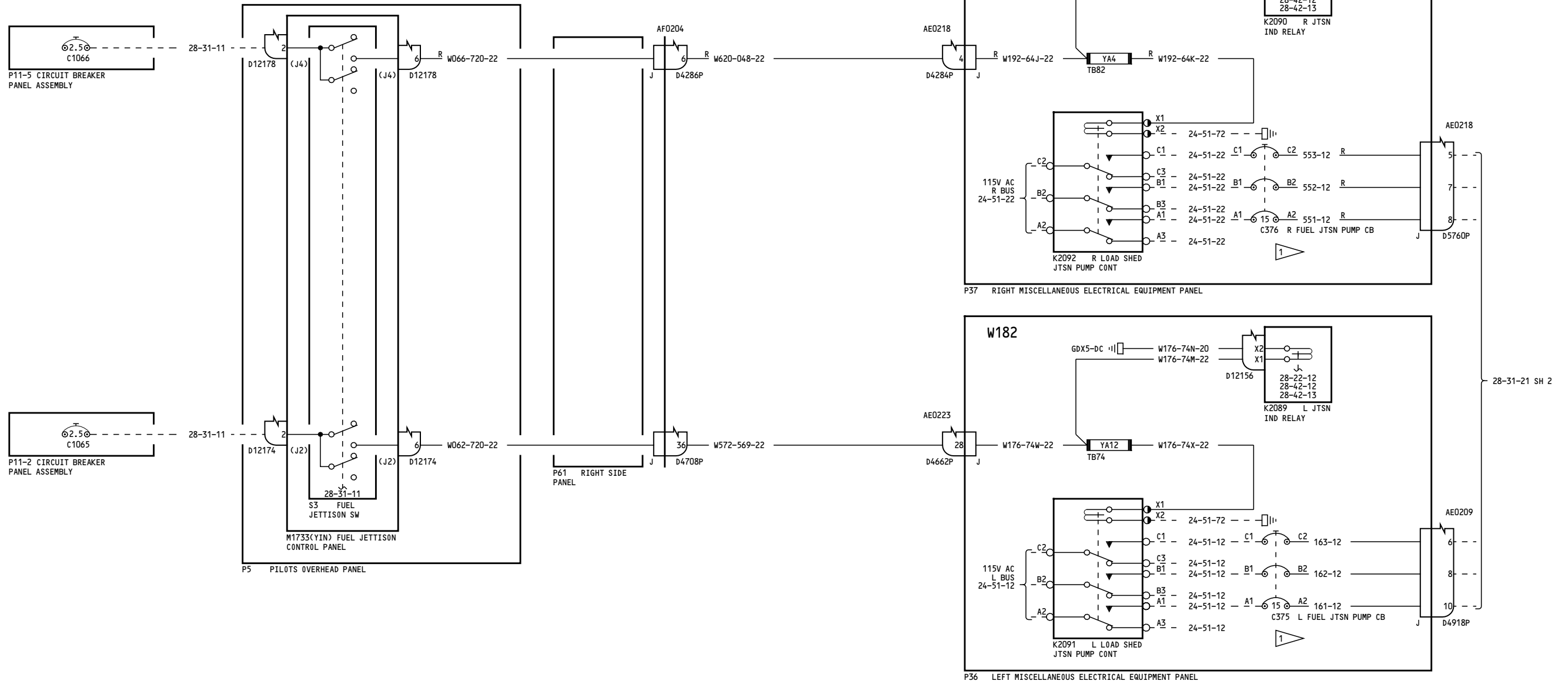

NOTES:  
1 COLLARED AND LABELED "INOP"

155-157, 165-199, 277-299	<b>FUEL JETTISON PUMPS</b>
	D280T132

**28-31-21**

Page 2  
Sheet 1  
Jan 21/2005

**28-31-21**

Page 2  
Sheet 1  
Jan 21/2005

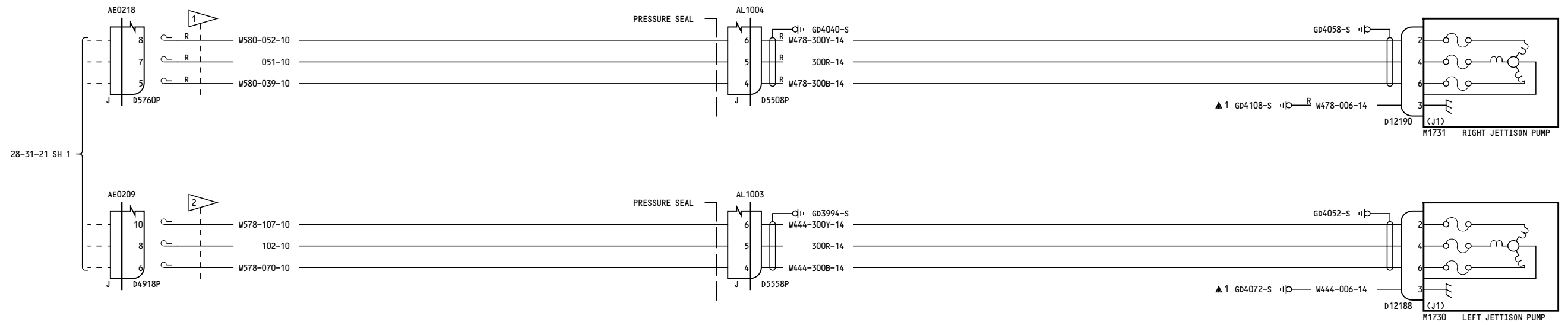

- NOTES:
- 1 CAP & STOW NEAR D5760P
  - 2 CAP & STOW NEAR D4918P

155-157, 165-199, 277-299	<b>FUEL JETTISON PUMPS</b>
	D280T132

**28-31-21**  
 Page 2  
 Sheet 2  
 Jan 21/2005

**28-31-21**  
 Page 2  
 Sheet 2  
 Jan 21/2005

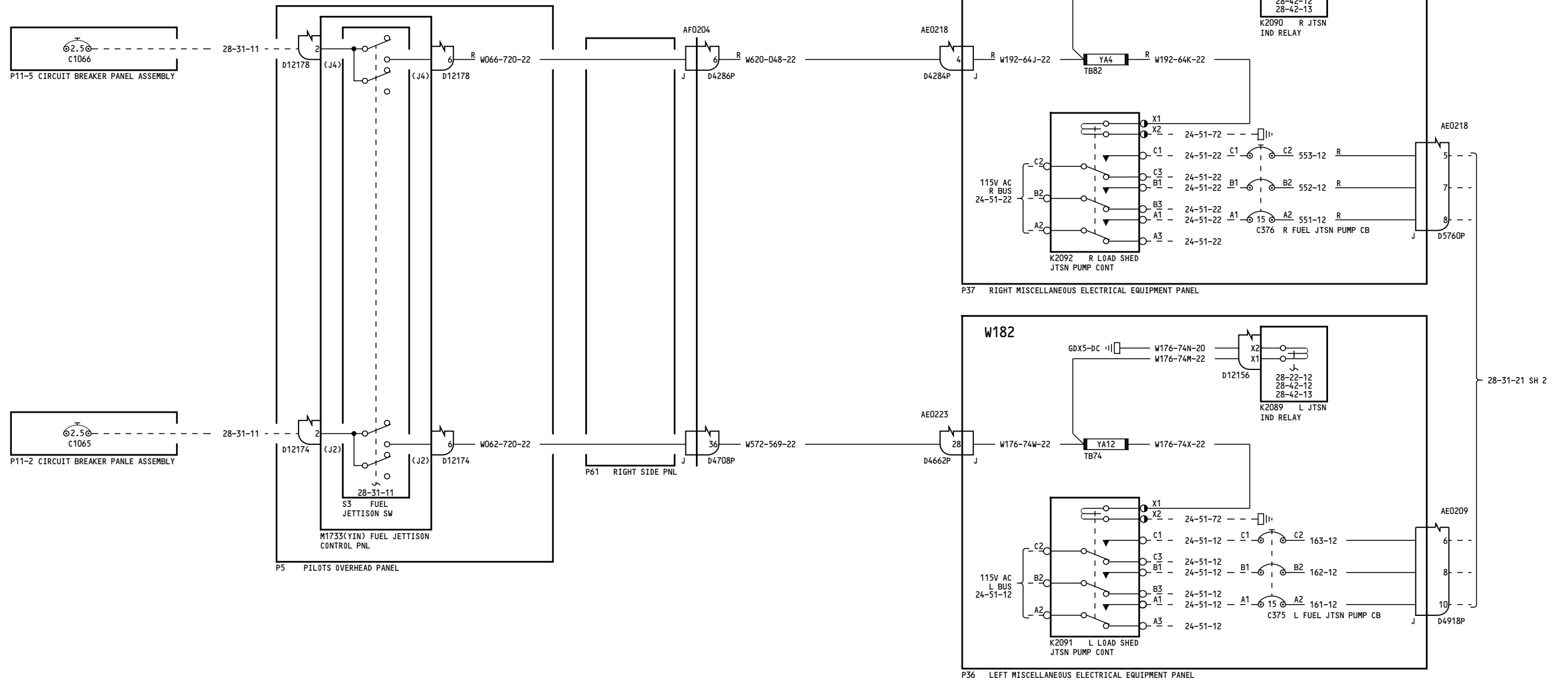

155-157, 165-167, 277-280

**FUEL JETTISON PUMPS**

D280T132

**28-31-21**

Page 2.1  
Sheet 1  
Jan 21/2005

Incorporates  
28-0038 R02

**28-31-21**

Page 2.1  
Sheet 1  
Jan 21/2005

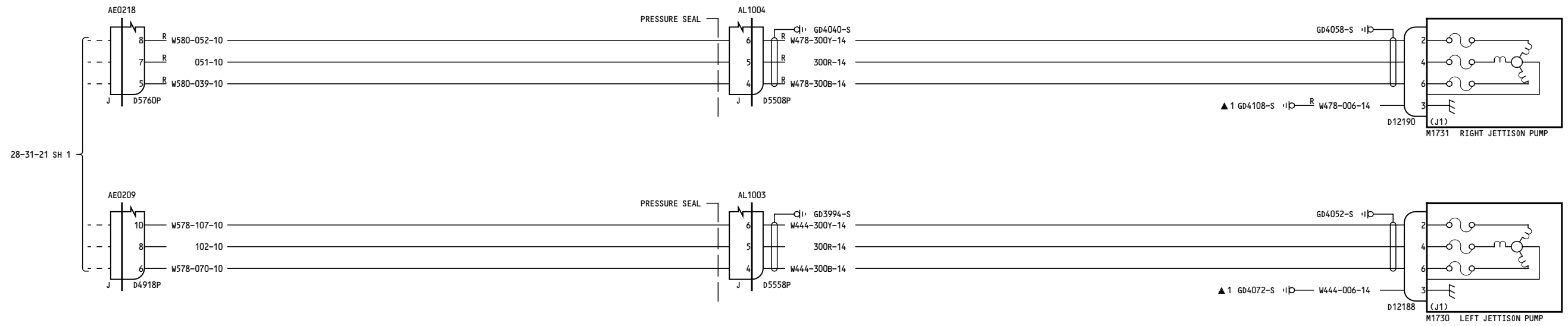

155-157, 165-167, 277-280

**FUEL JETTISON PUMPS**

D280T132

**28-31-21**

Page 2.1  
Sheet 2  
Jan 21/2005

Incorporates  
28-0038 R02

**28-31-21**

Page 2.1  
Sheet 2  
Jan 21/2005

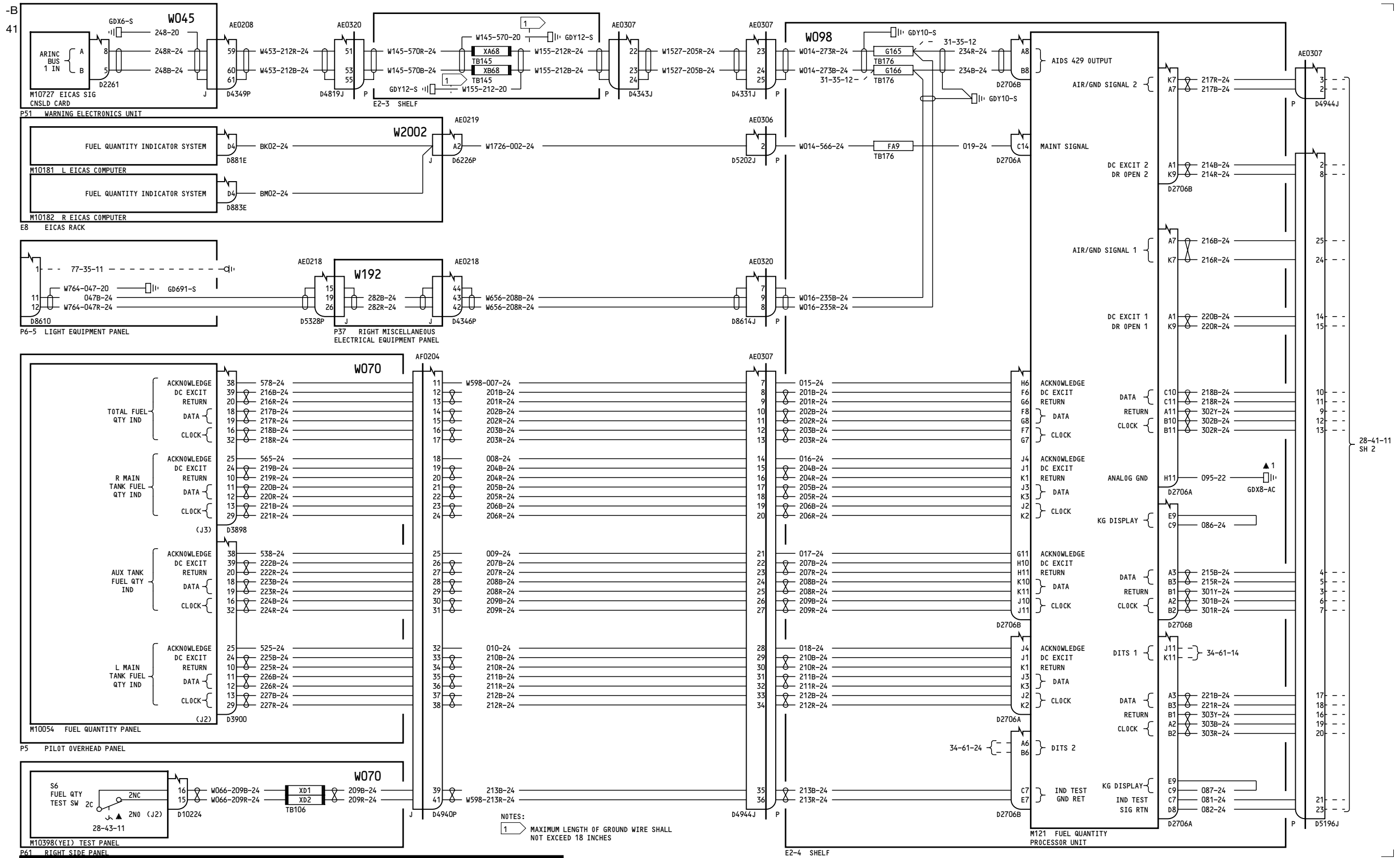

050-099

**FUEL QUANTITY INDICATION**

BOEING PROPRIETARY - Copyright © - Unpublished Work - See title page for details.

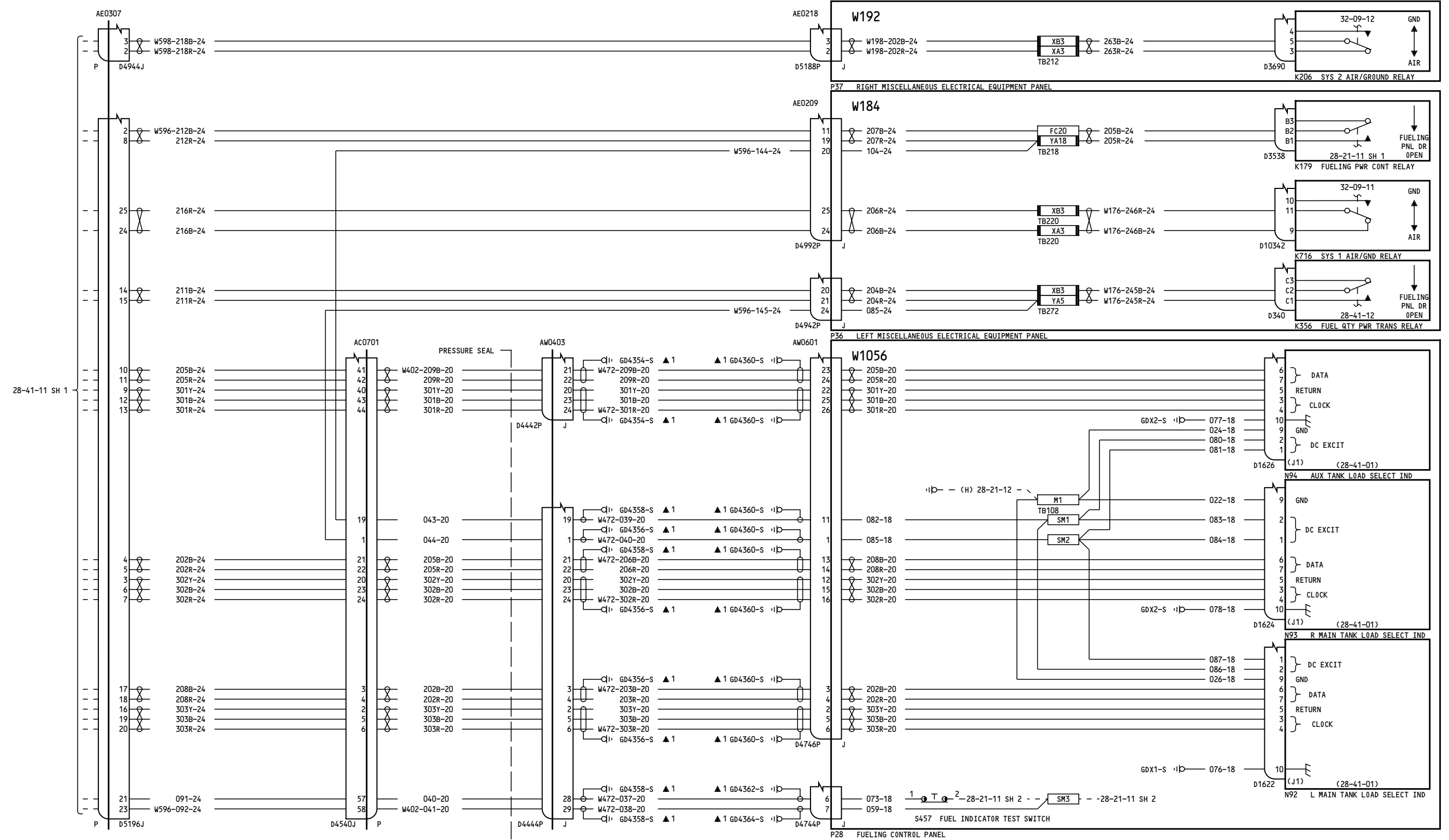

050-099

FUEL QUANTITY INDICATION

28-41-11

Page 1  
Sheet 2  
Jan 21/2005

D280T132

28-41-11

Page 1  
Sheet 2  
Jan 21/2005



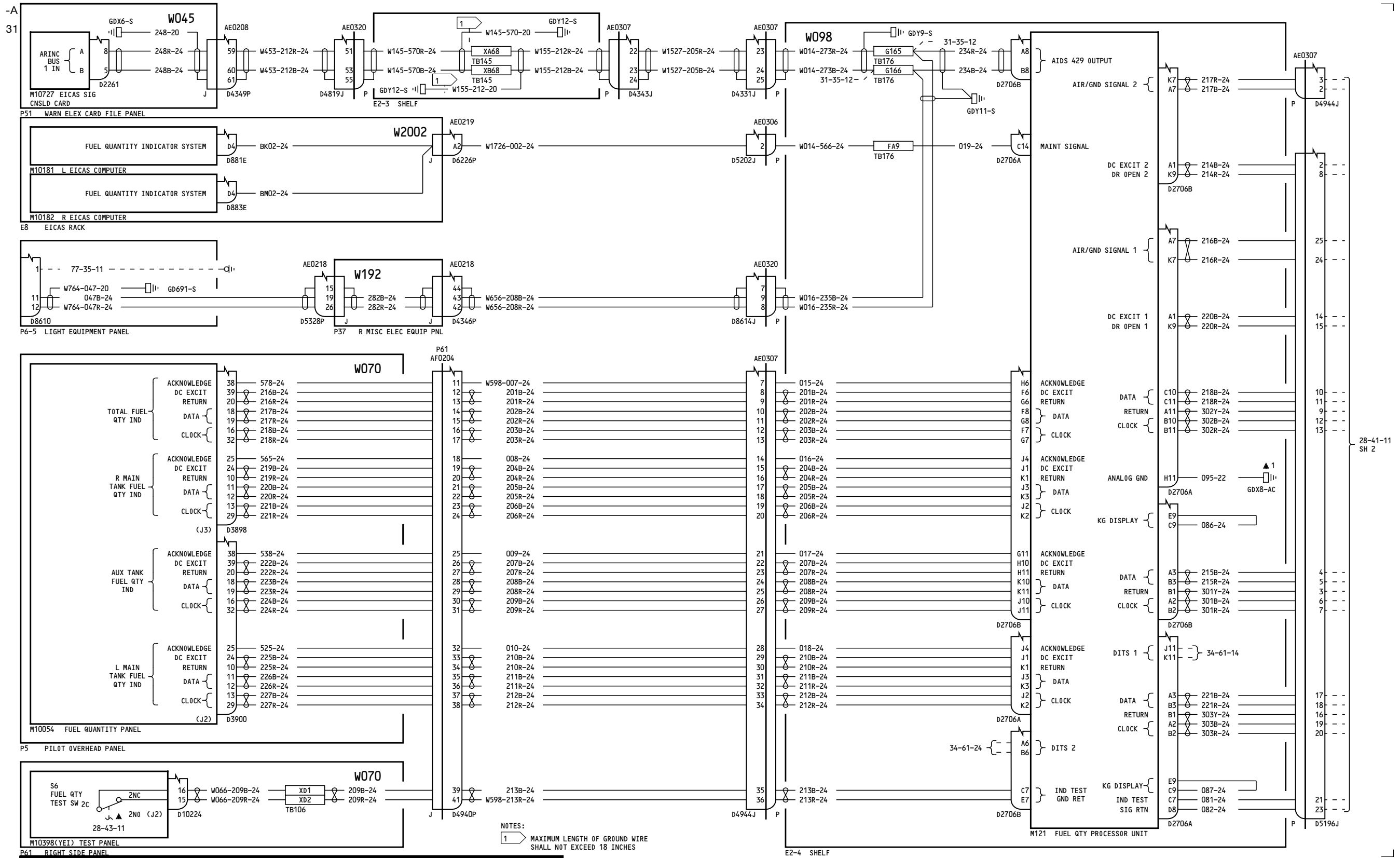

150-157

FUEL QUANTITY INDICATION

28-41-11

Page 2  
Sheet 1  
Jan 21/2005

D280T132

28-41-11

Page 2  
Sheet 1  
Jan 21/2005

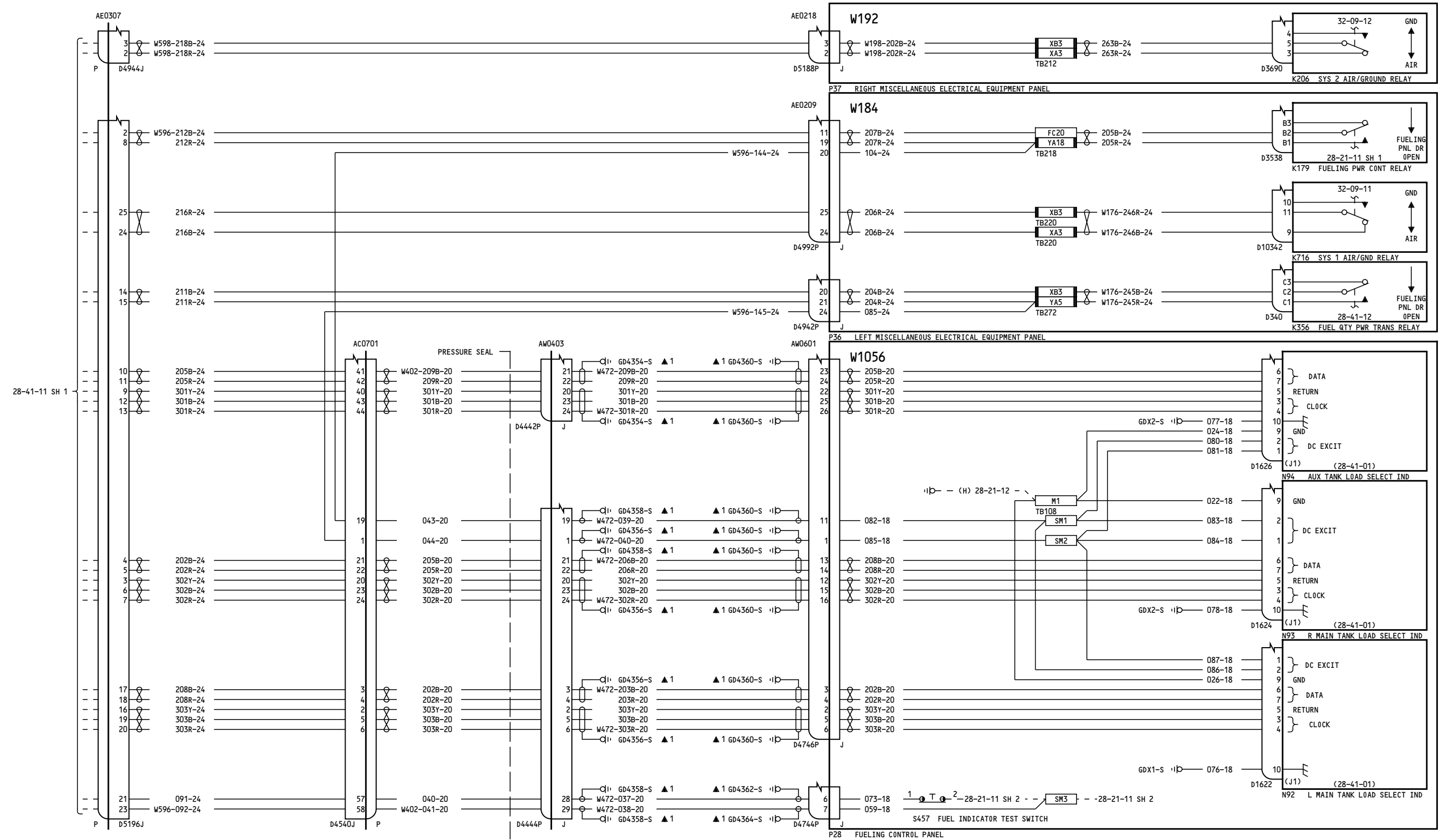

150-157

**FUEL QUANTITY INDICATION**

**28-41-11**

Page 2  
Sheet 2  
Jan 21/2005

D280T132

**28-41-11**

Page 2  
Sheet 2  
Jan 21/2005

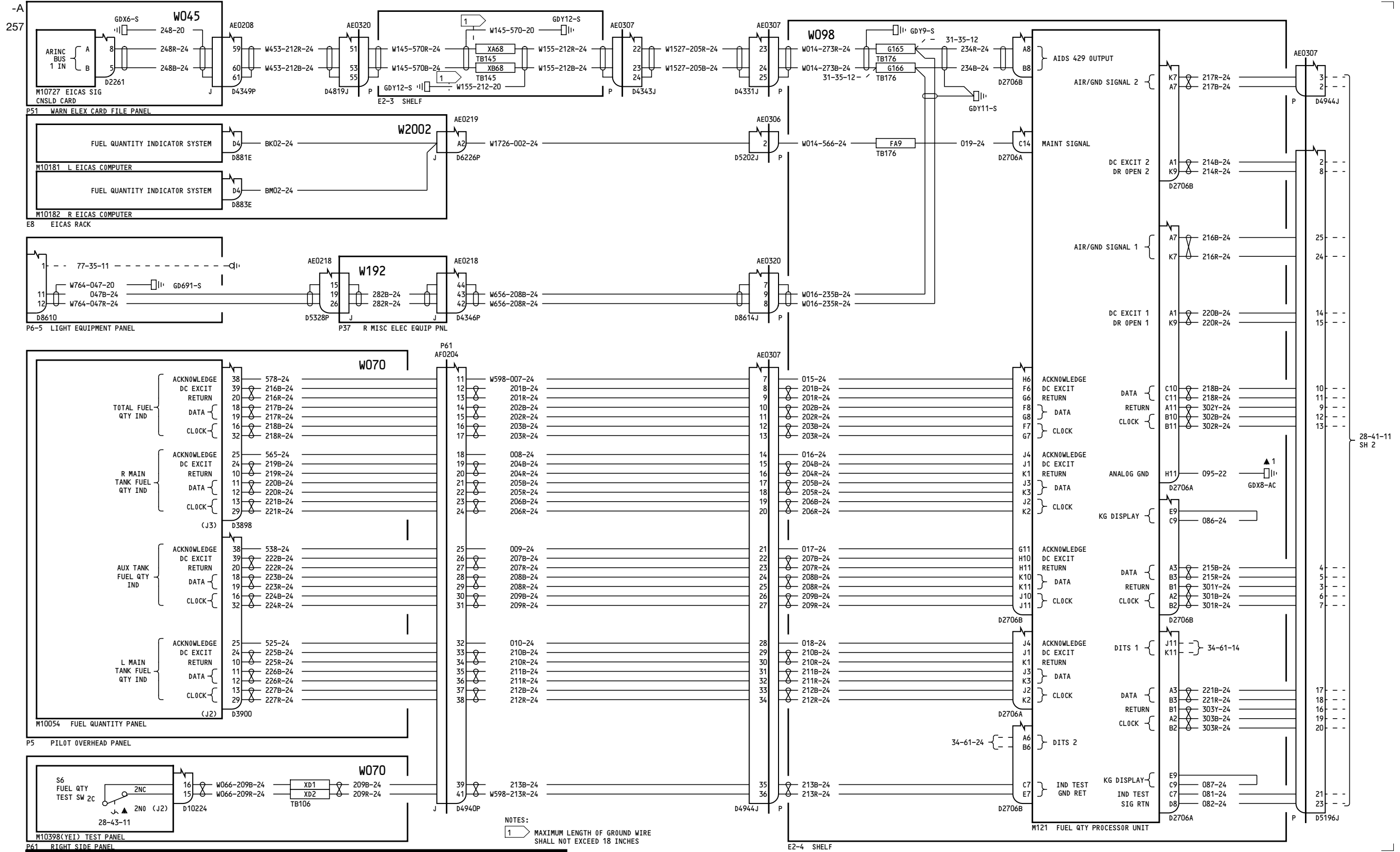

FUEL QUANTITY INDICATION

28-41-11

Page 2.1  
Sheet 1  
Mar 14/2007

D280T132

Incorporates  
31-0208  
31-0248

28-41-11

Page 2.1  
Sheet 1  
Mar 14/2007

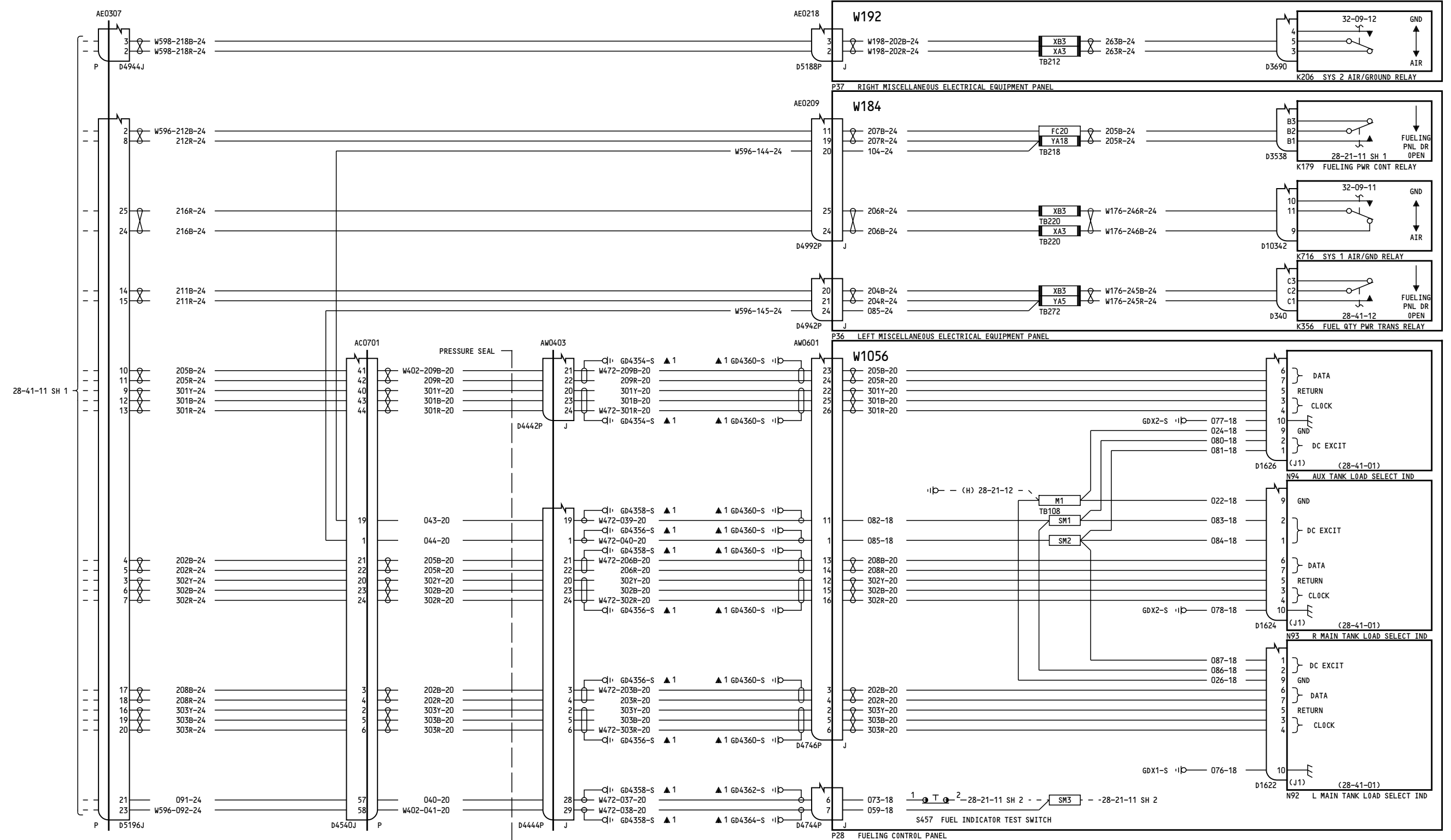

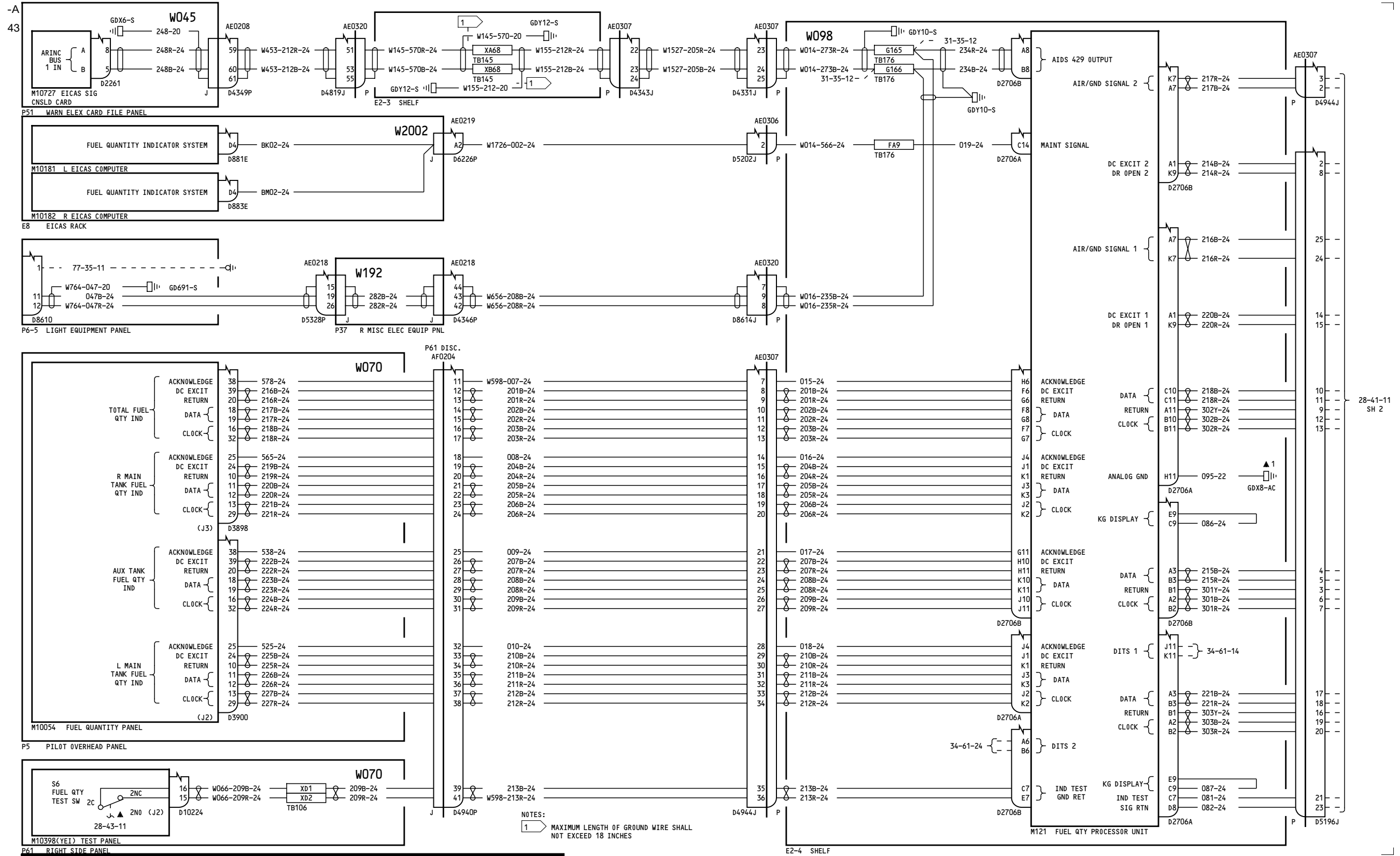

162-199

**FUEL QUANTITY INDICATION**

**28-41-11**

Page 3  
Sheet 1  
Jan 21/2005

D280T132

**28-41-11**

Page 3  
Sheet 1  
Jan 21/2005

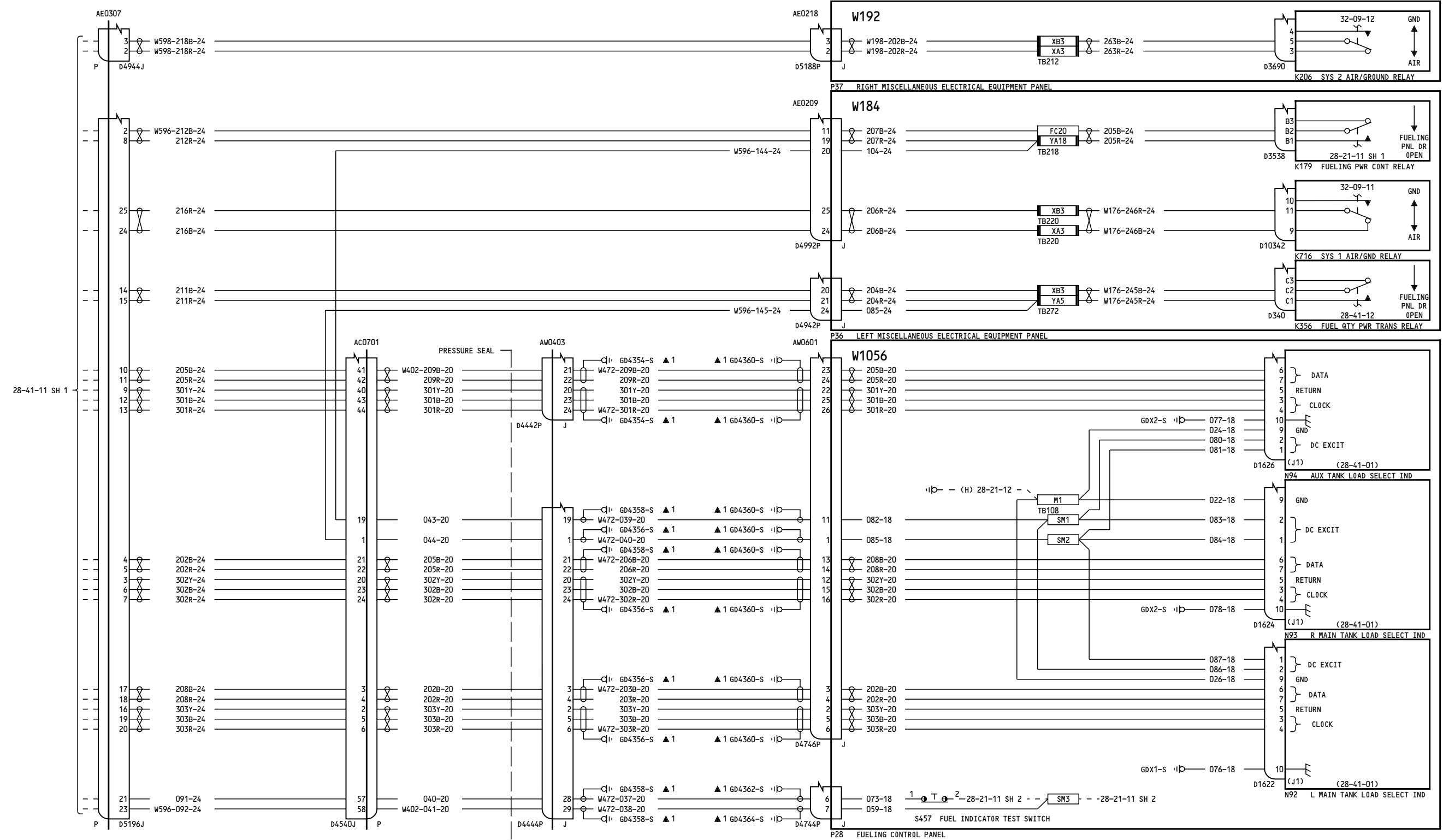

162-199

FUEL QUANTITY INDICATION

28-41-11

Page 3  
Sheet 2  
Jan 21/2005

D280T132

28-41-11

Page 3  
Sheet 2  
Jan 21/2005

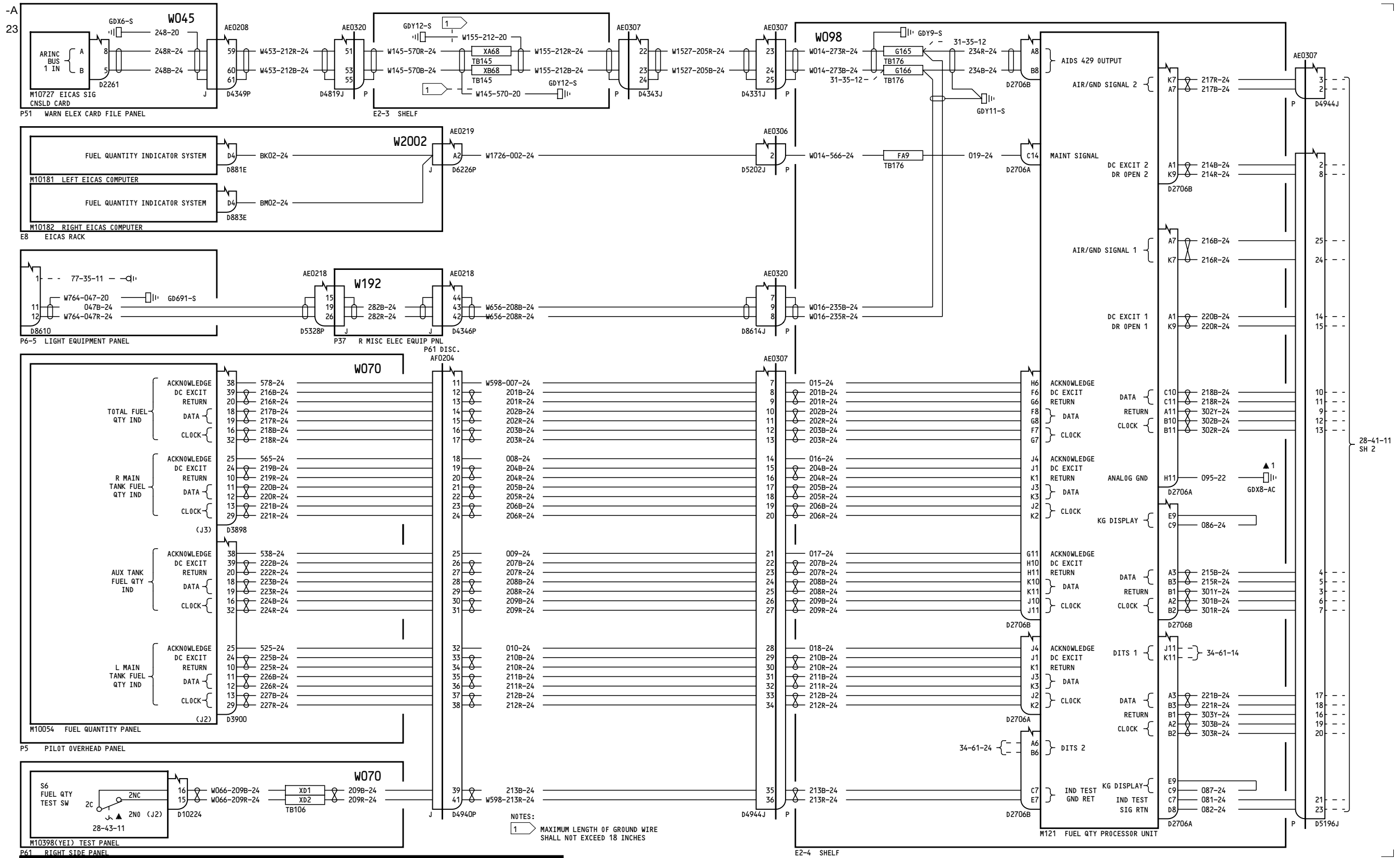

FUEL QUANTITY INDICATION

28-41-11

D280T132

28-41-11

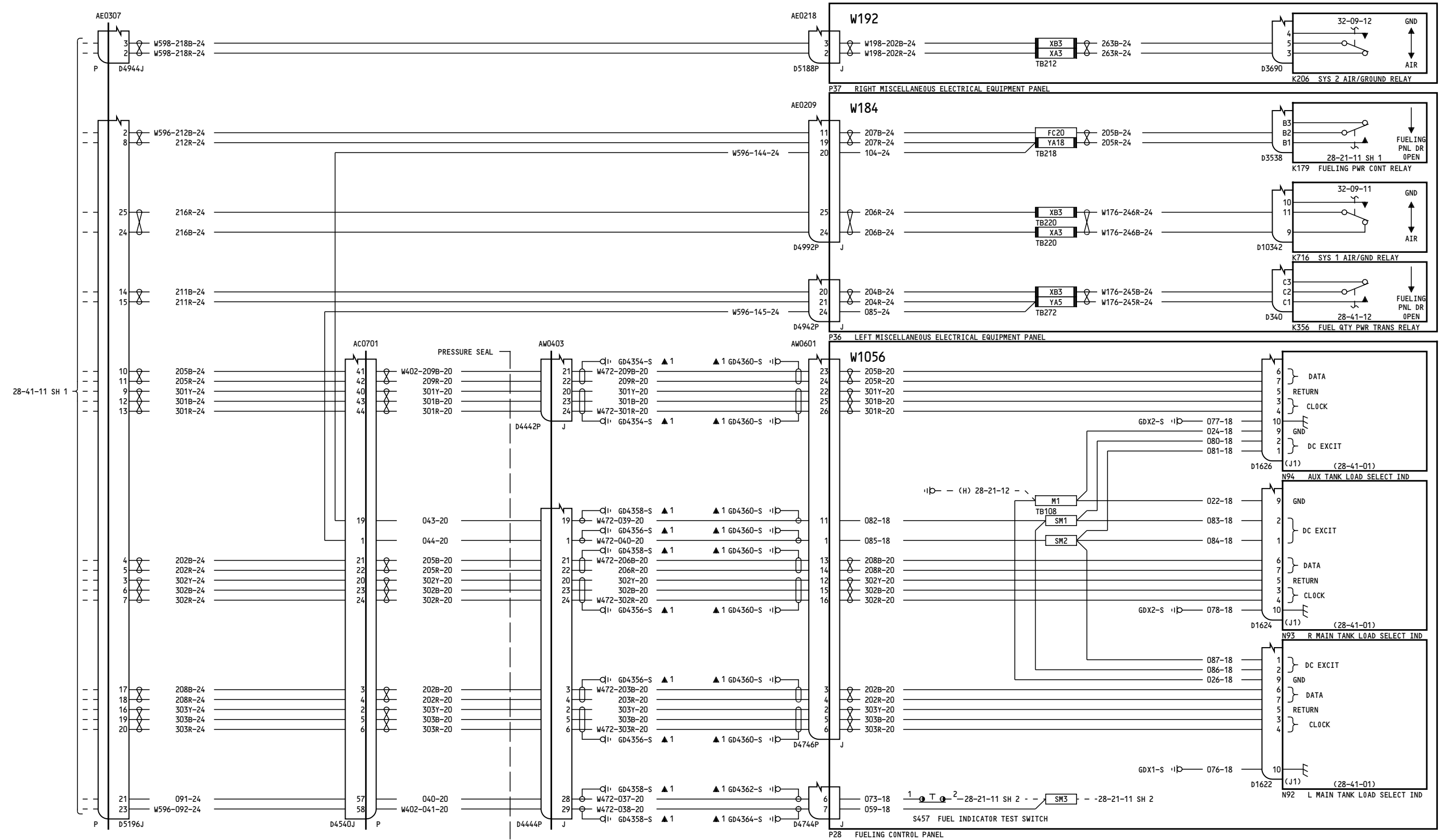

275-276

FUEL QUANTITY INDICATION

28-41-11

Page 4  
Sheet 2  
Jan 21/2005

D280T132

28-41-11

Page 4  
Sheet 2  
Jan 21/2005



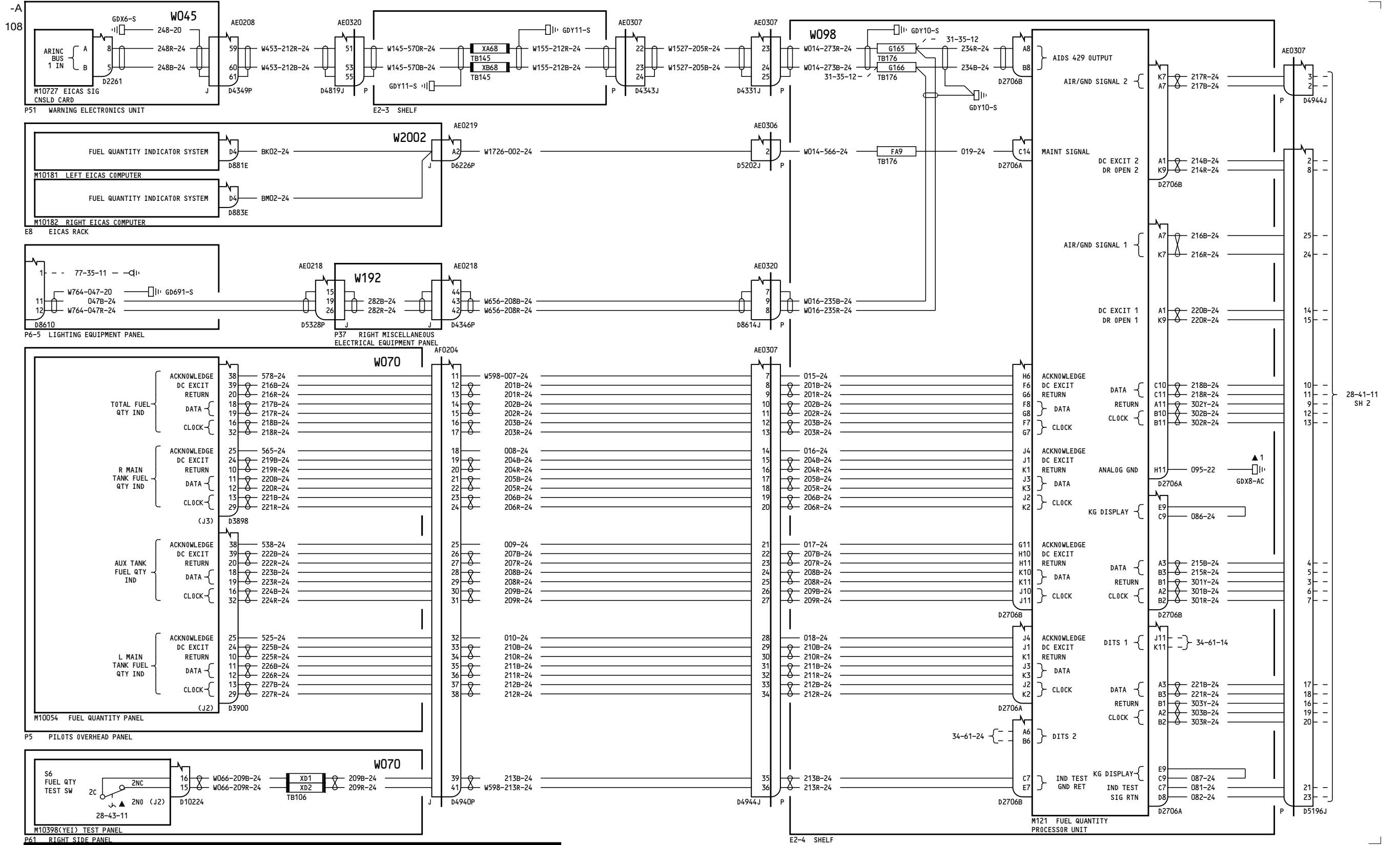

277-299

**FUEL QUANTITY INDICATION**

D280T132

BOEING PROPRIETARY - Copyright © - Unpublished Work - See title page for details.

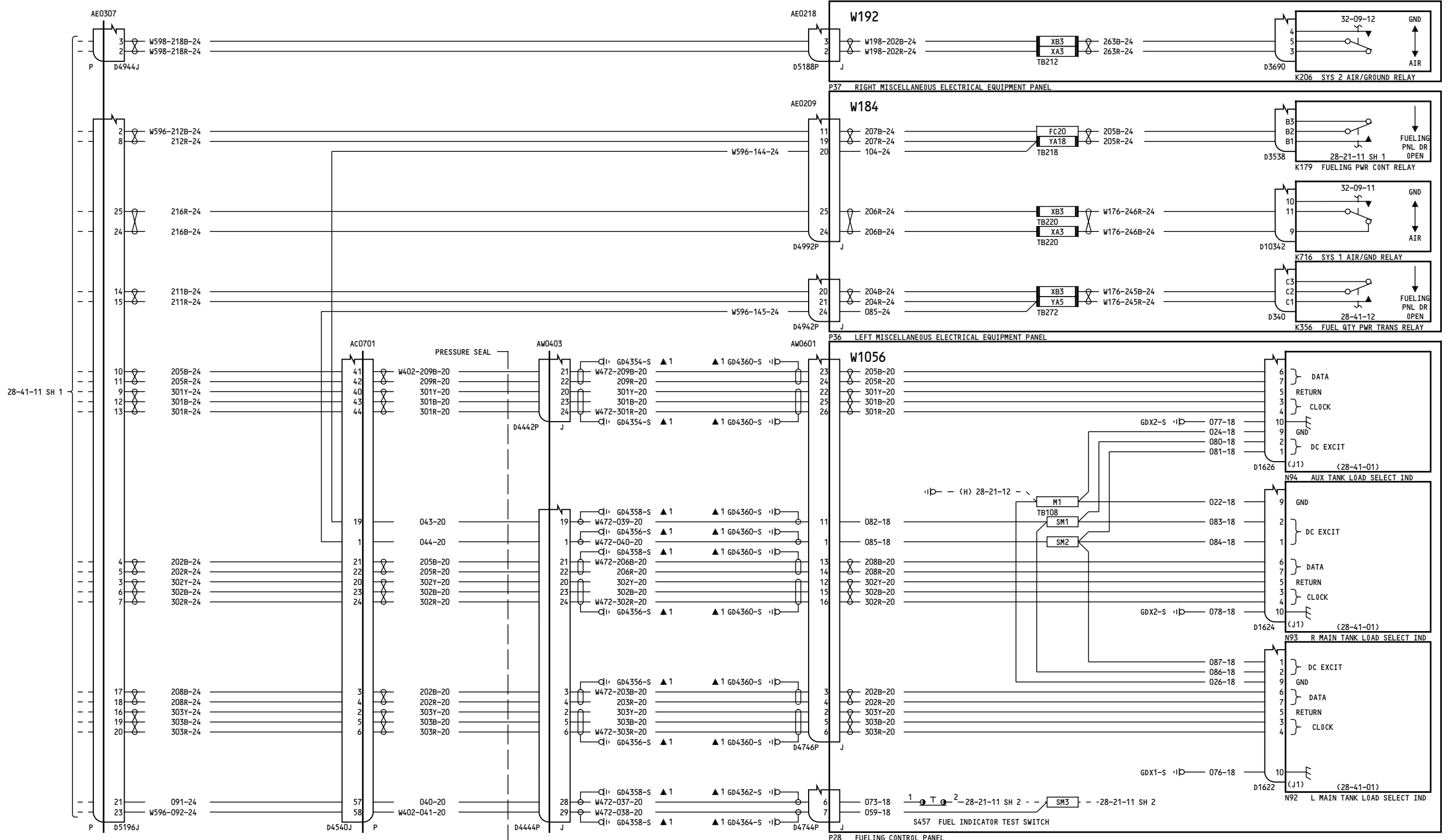

BOEING PROPRIETARY - Copyright © - Unpublished Work - See title page for details.

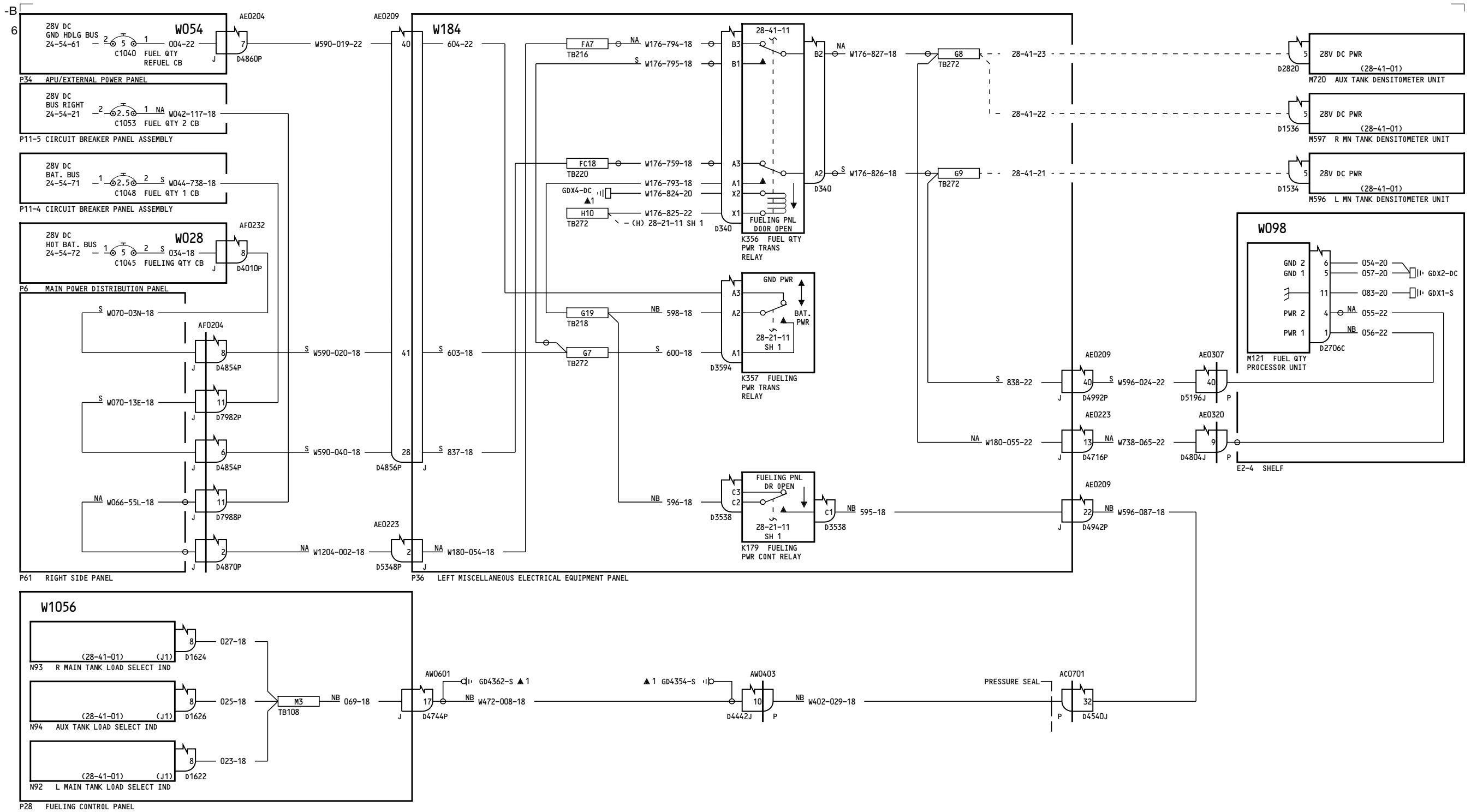

ALL

**FUEL QUANTITY INDICATING SYSTEM POWER**

D280T132

**28-41-12**

Page 1

Jan 21/2005

**28-41-12**

Page 1

Jan 21/2005

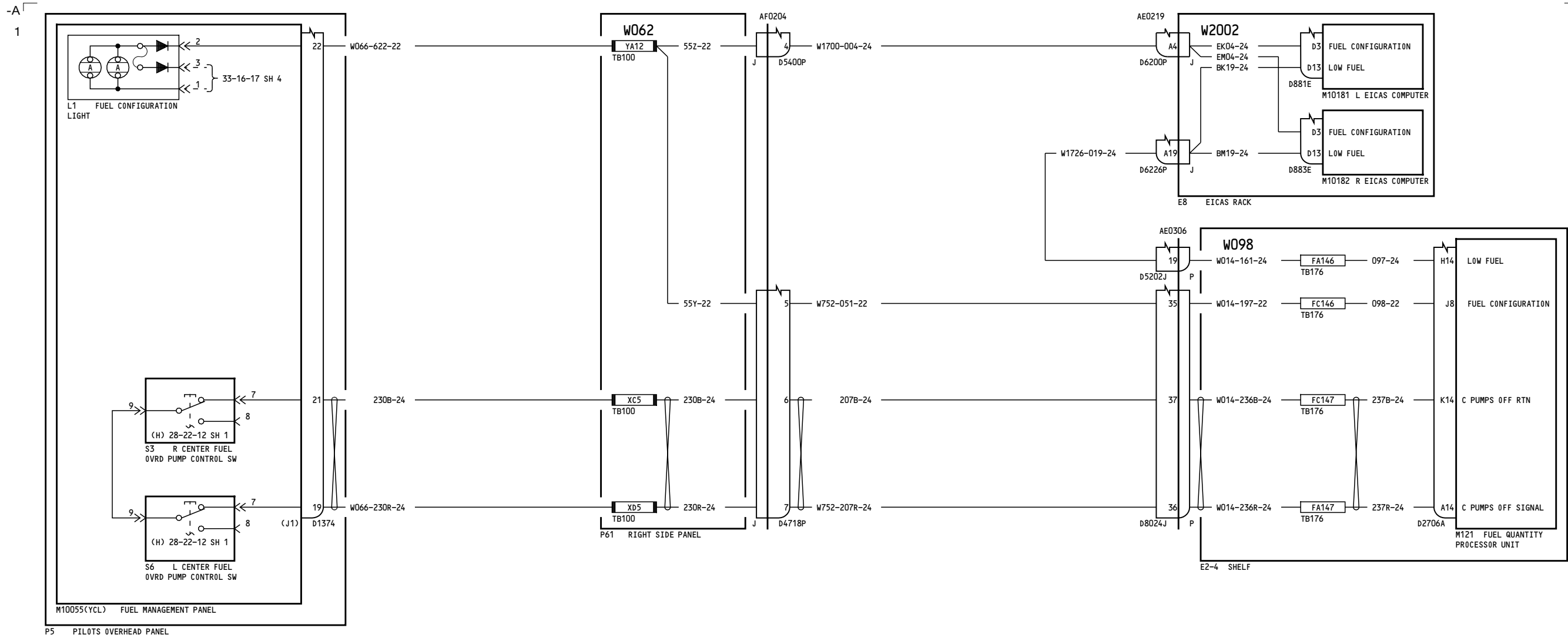

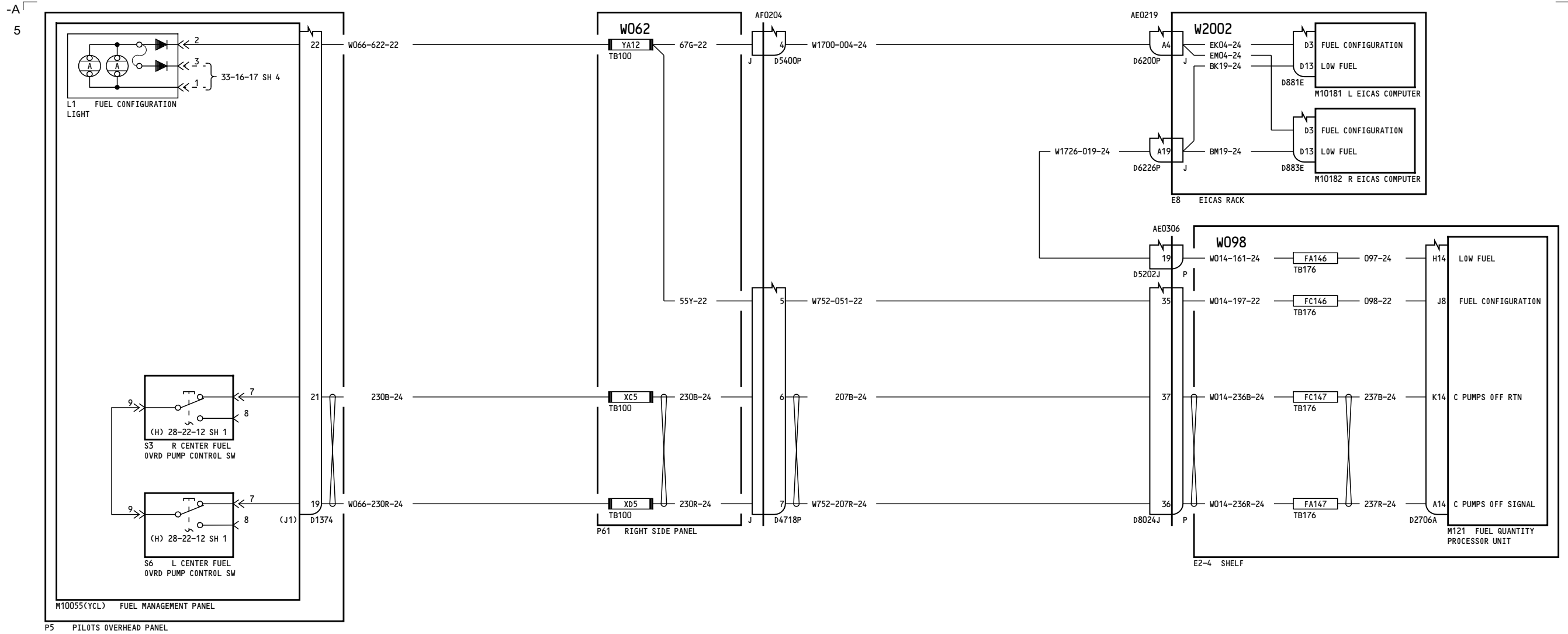

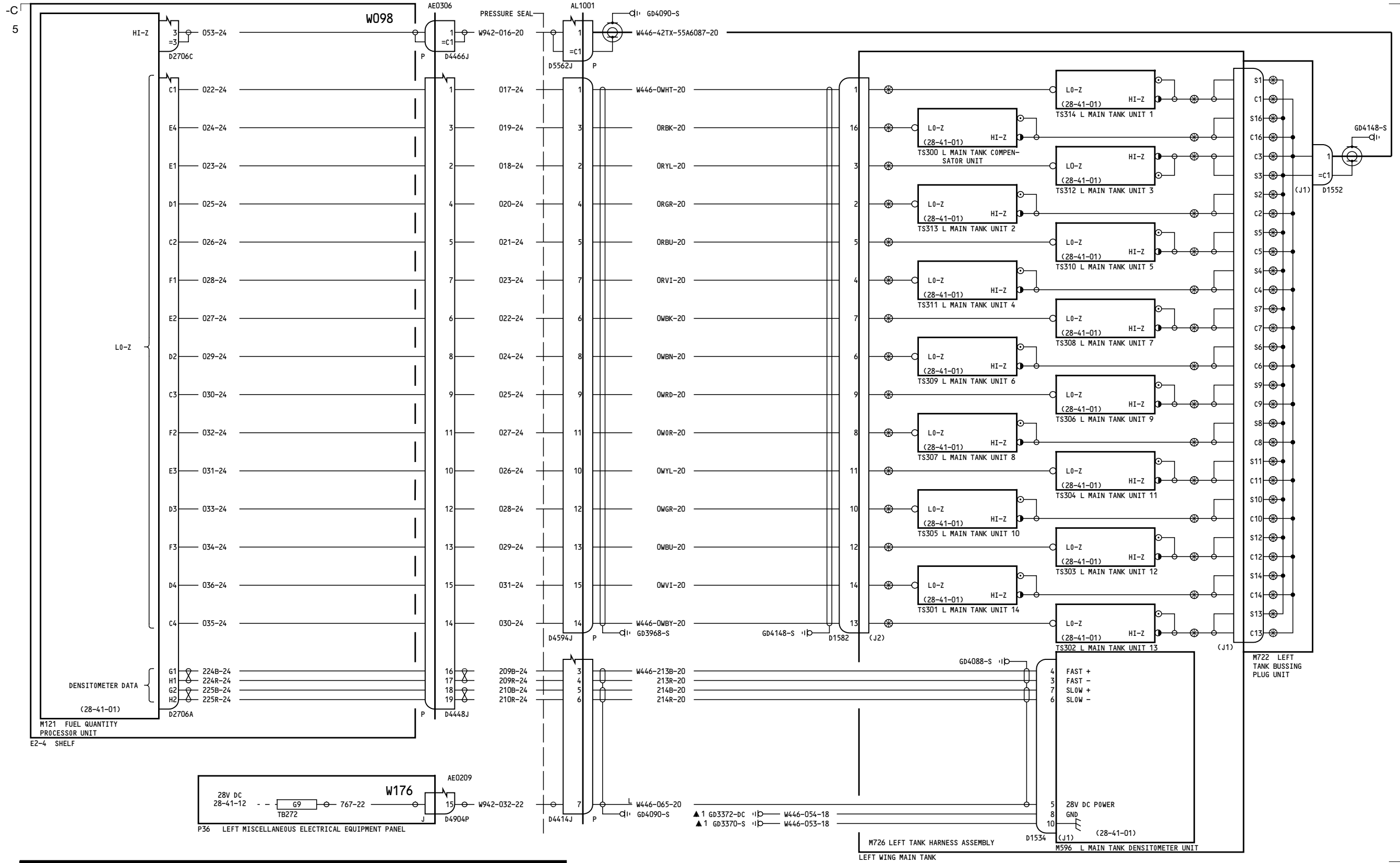

ALL

**FUEL QUANTITY SENSORS-  
LEFT MAIN TANK**

D280T132

**28-41-21**

Page 1

Jan 21/2005

**28-41-21**

Page 1

Jan 21/2005

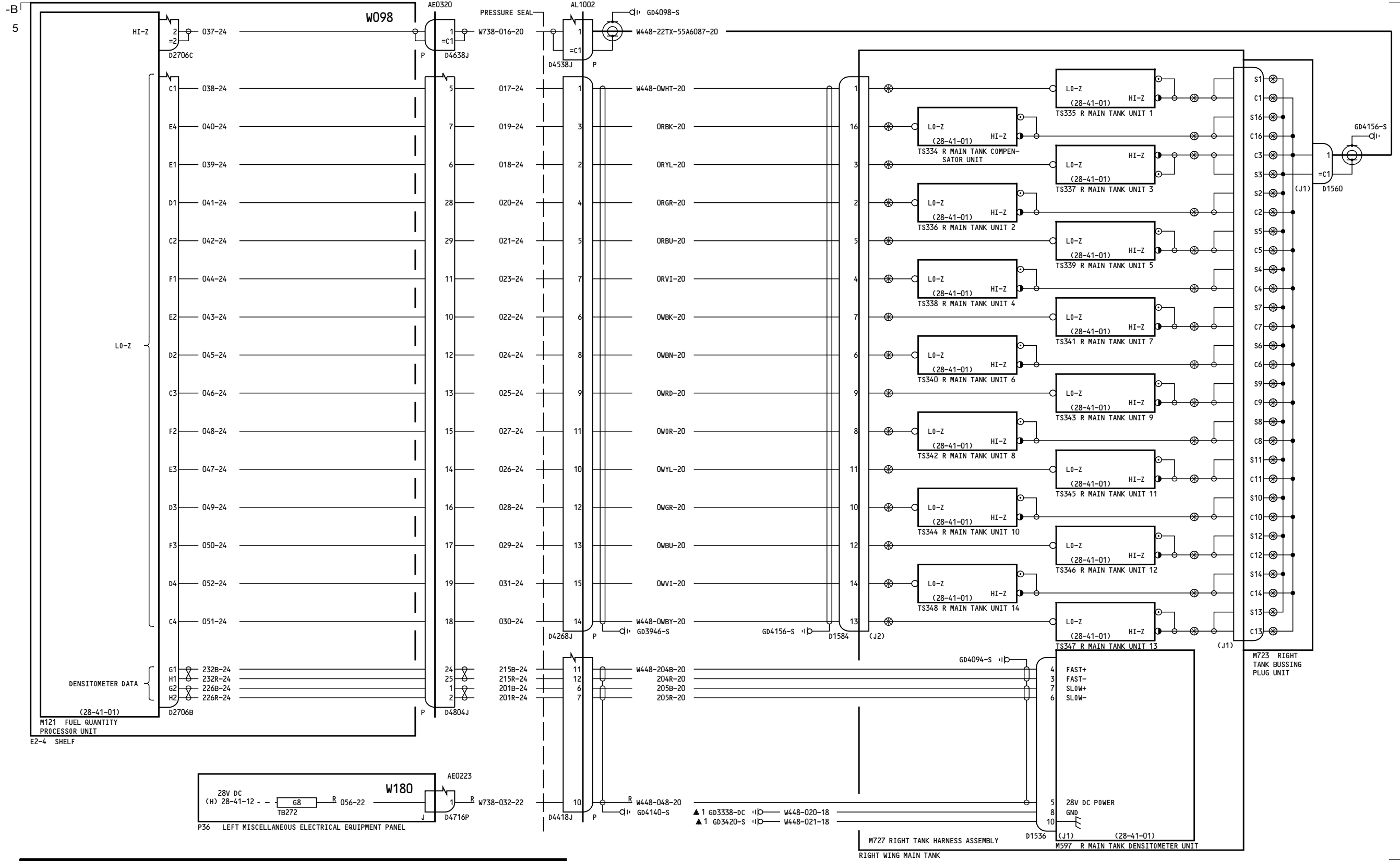

ALL

**FUEL QUANTITY SENSORS-  
RIGHT MAIN TANK**

D280T132

**28-41-22**

Page 1

Jan 21/2005

**28-41-22**

Page 1

Jan 21/2005

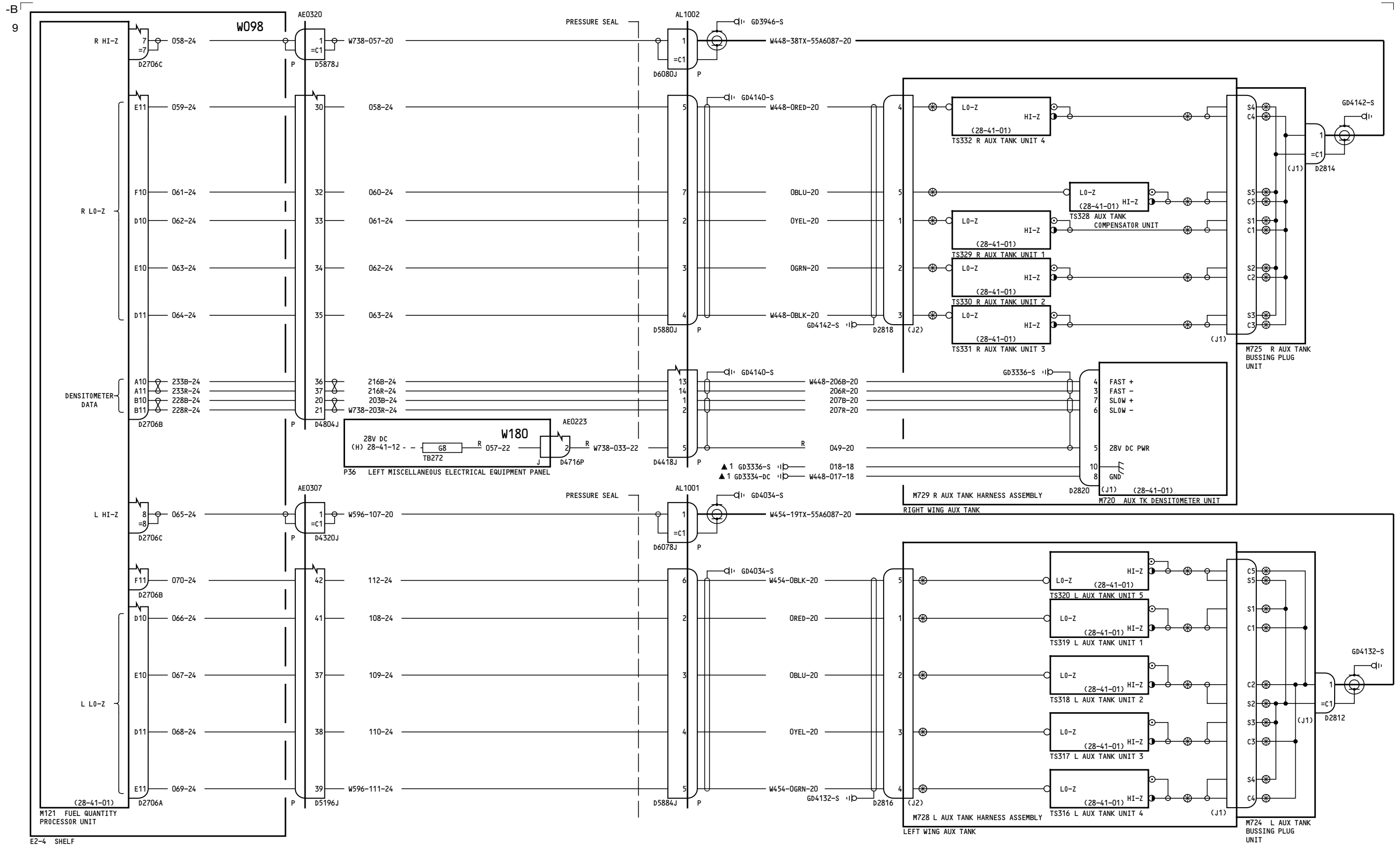

ALL

**FUEL QUANTITY SENSORS-  
AUXILIARY TANKS**

**28-41-23**

Page 1

Jan 21/2005

D280T132

**28-41-23**

Page 1

Jan 21/2005





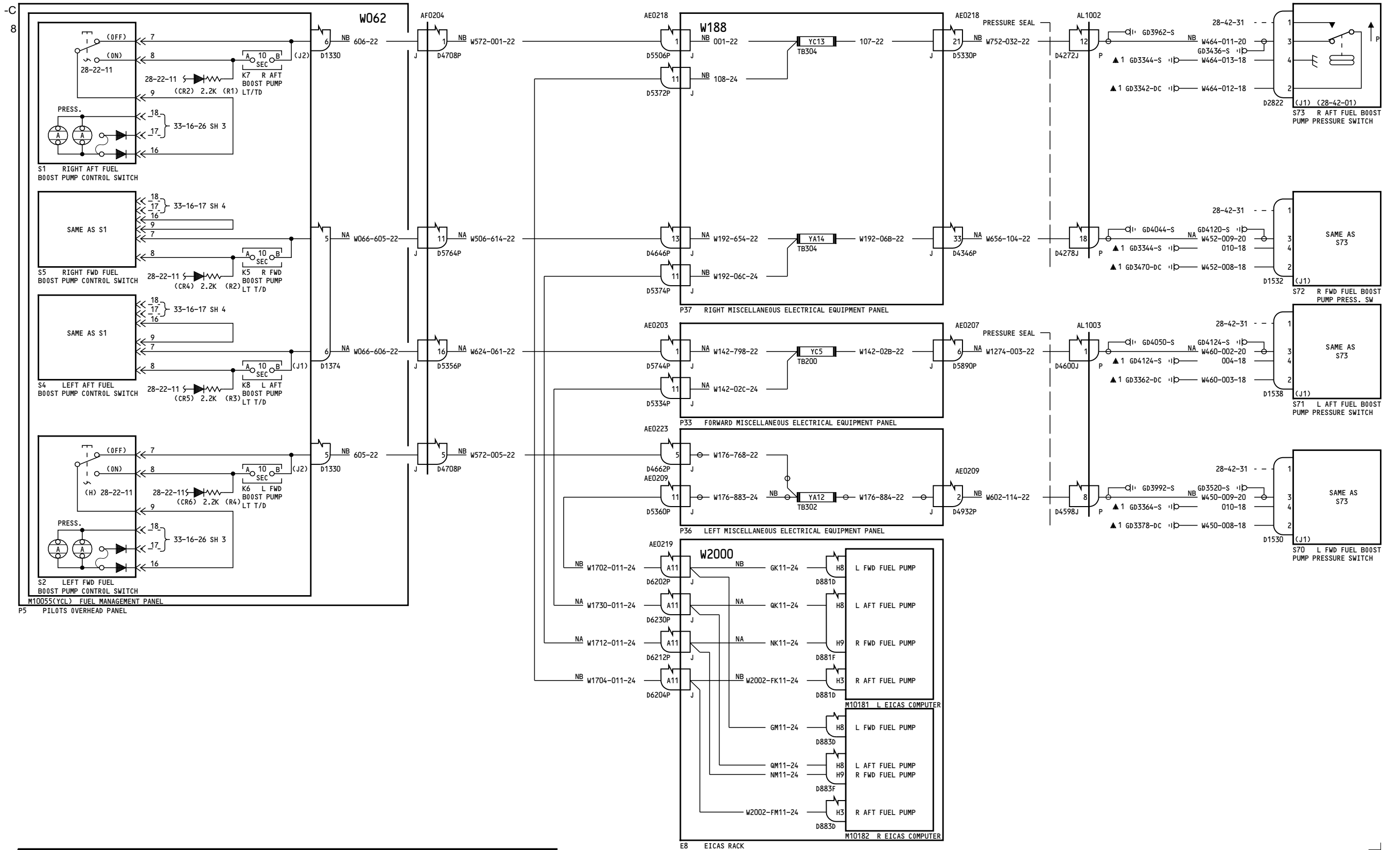

155-157, 166-199, 277-299

**LOW FUEL PRESSURE INDICATOR-BOOST PUMPS**

**28-42-11**

Page 2

D280T132

Jan 21/2005

**28-42-11**

Page 2

Jan 21/2005

13

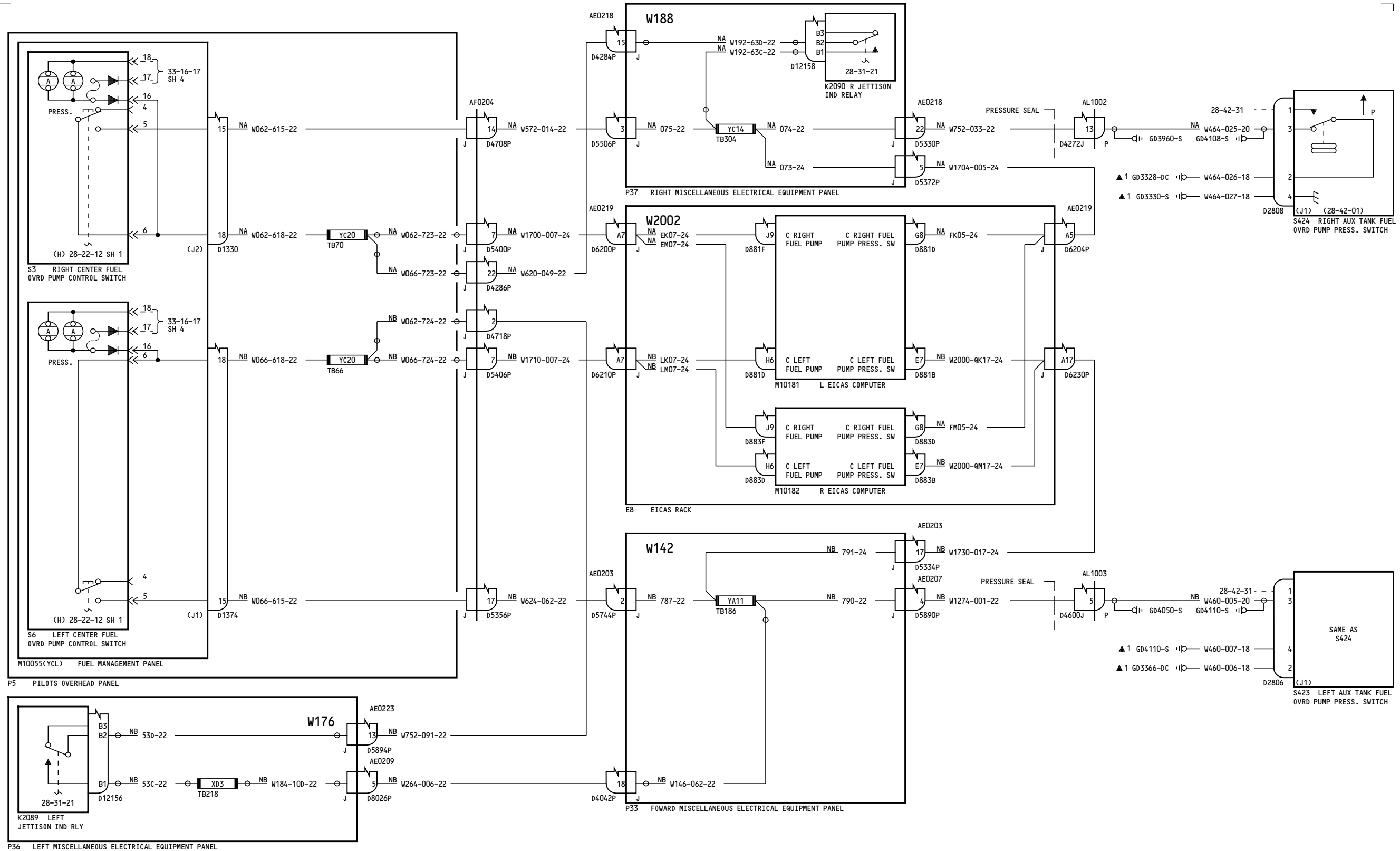

050-099, 276

**LOW FUEL PRESSURE INDICATOR-OVERRIDE PUMPS**

**28-42-12**

Page 1

D280T132

Jan 21/2005

**28-42-12**

Page 1

Jan 21/2005

89

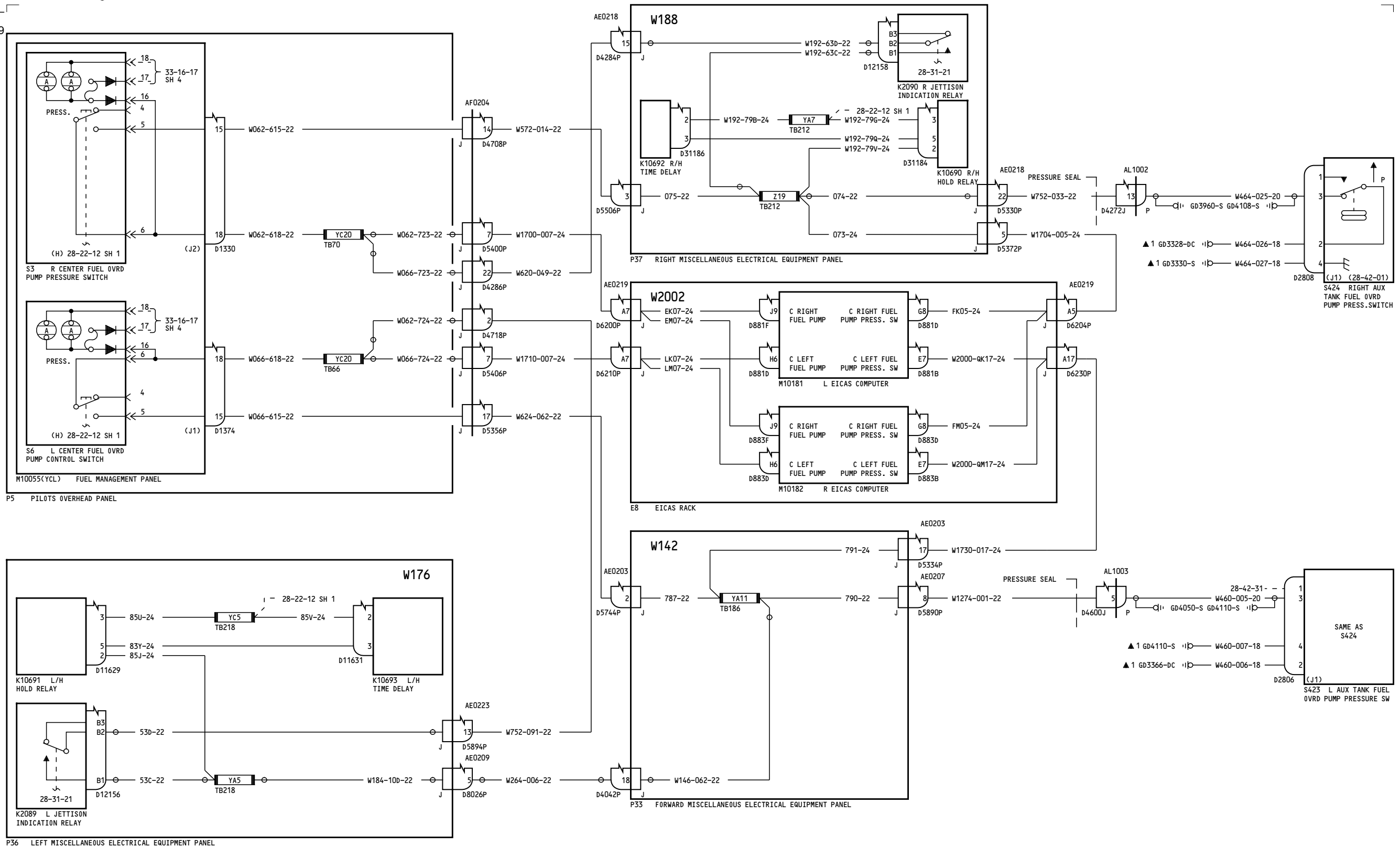

050-051, 155-167, 276-280

**LOW FUEL PRESSURE INDICATOR-OVERRIDE PUMPS**

**28-42-12**

Incorporates  
 ▸ 28-0034 R02  
 ▸ 28A0083 R01

Page 1.1

Feb 06/2009

D280T132

**28-42-12**

Page 1.1

Feb 06/2009

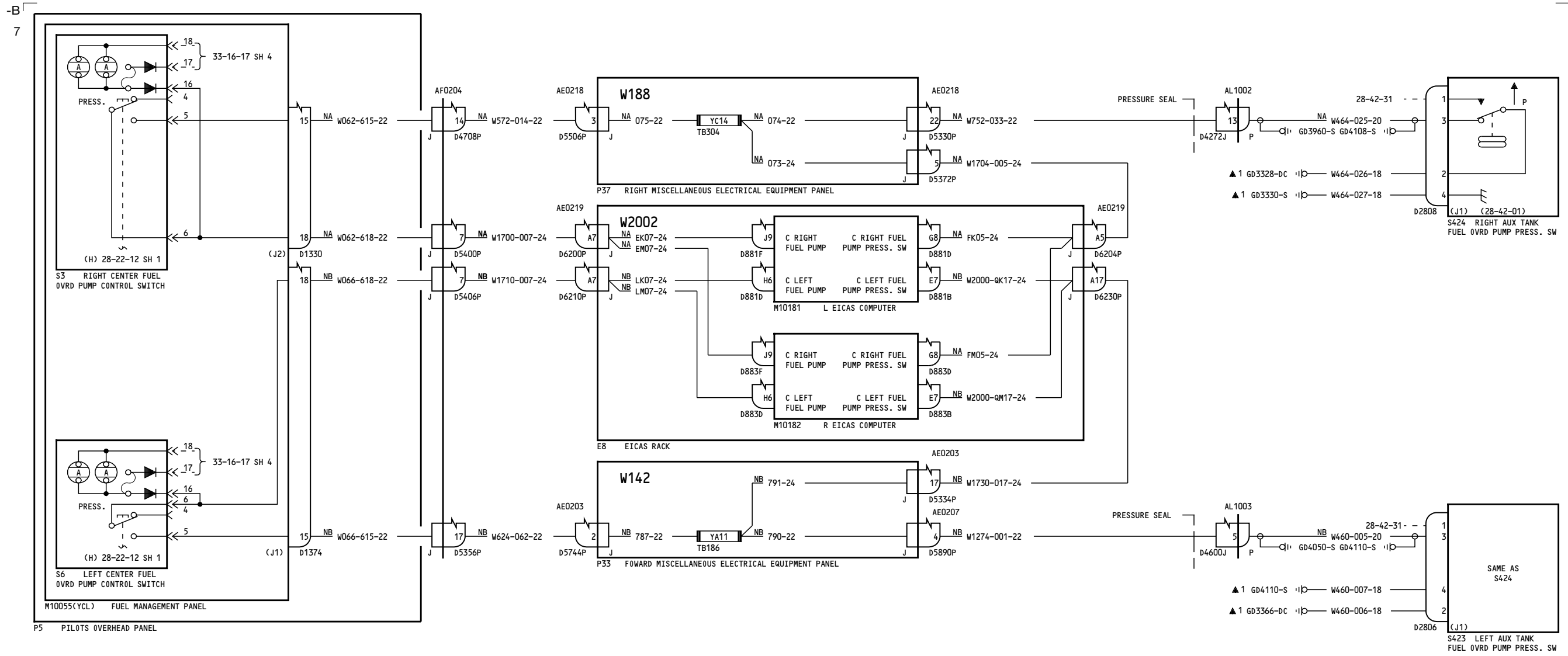

88

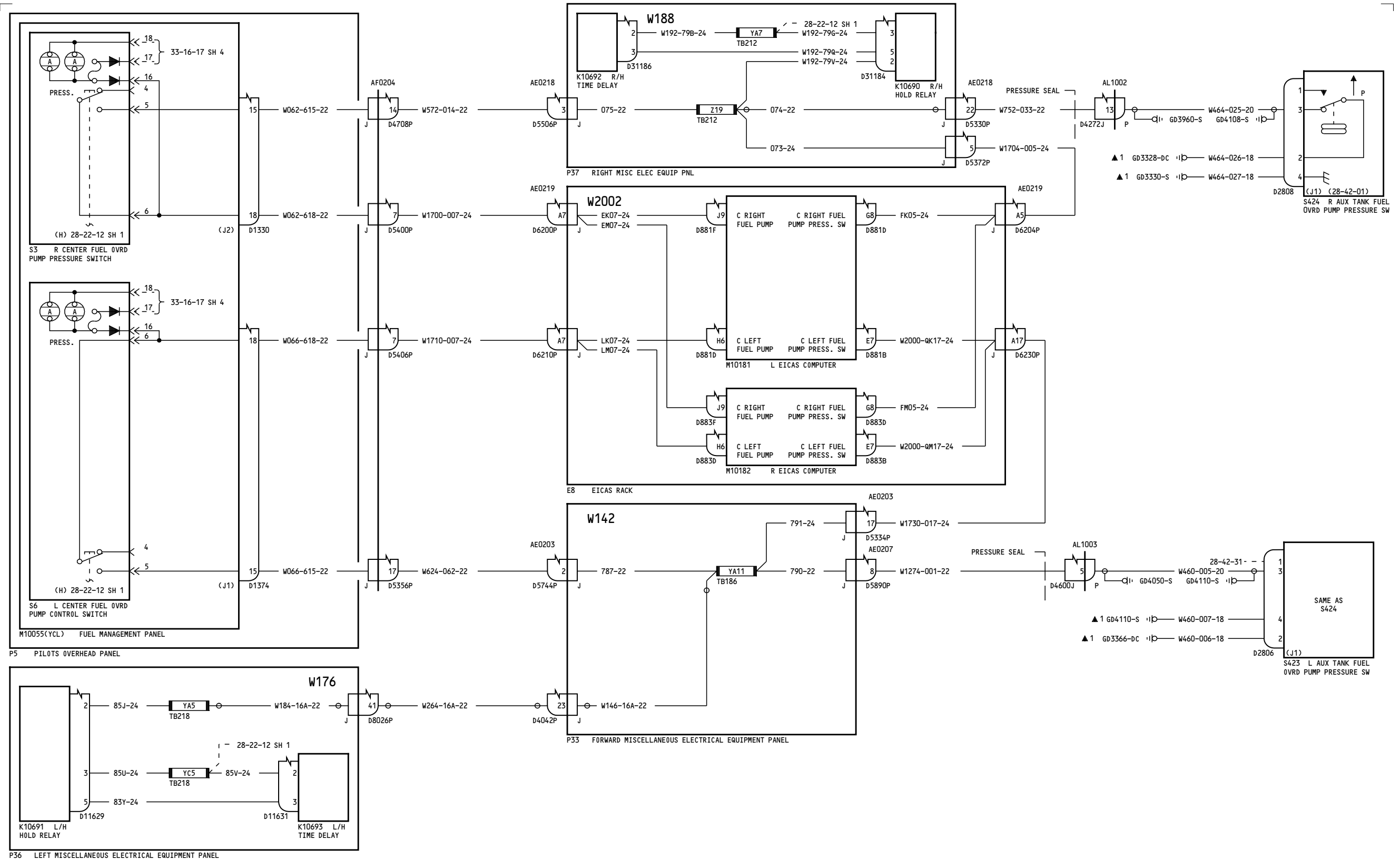

150-154, 275

**LOW FUEL PRESSURE INDICATOR-OVERRIDE PUMPS**

**28-42-12**

Page 2.1

Feb 06/2009

D280T132

Incorporates  
28-0034 R02  
28A0083 R01

**28-42-12**

Page 2.1

Feb 06/2009

-B  
6

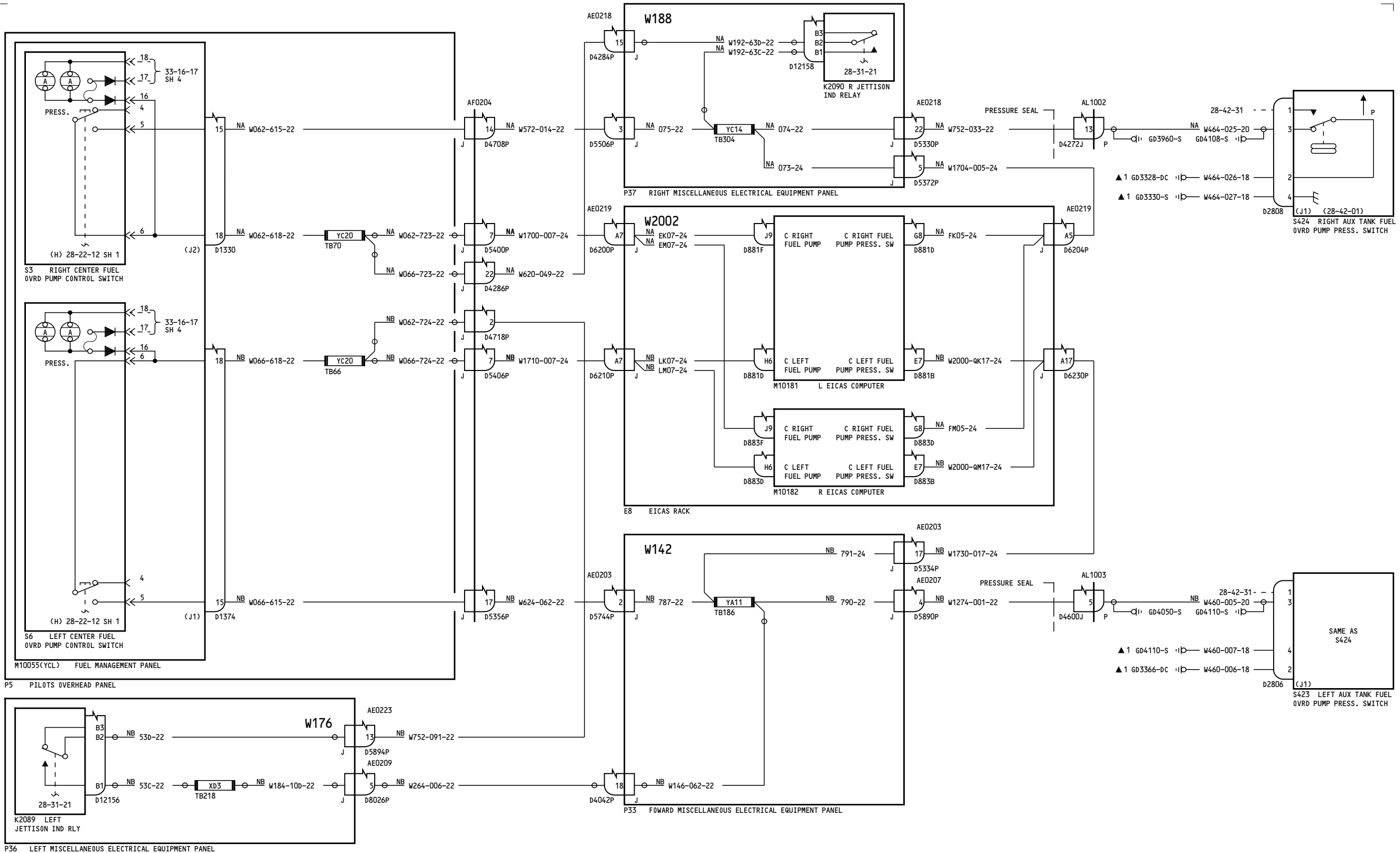

155-199, 277-299

**LOW FUEL PRESSURE INDICATOR-OVERRIDE PUMPS**

**28-42-12**

Page 3

D280T132

Jan 21/2005

**28-42-12**

Page 3

Jan 21/2005

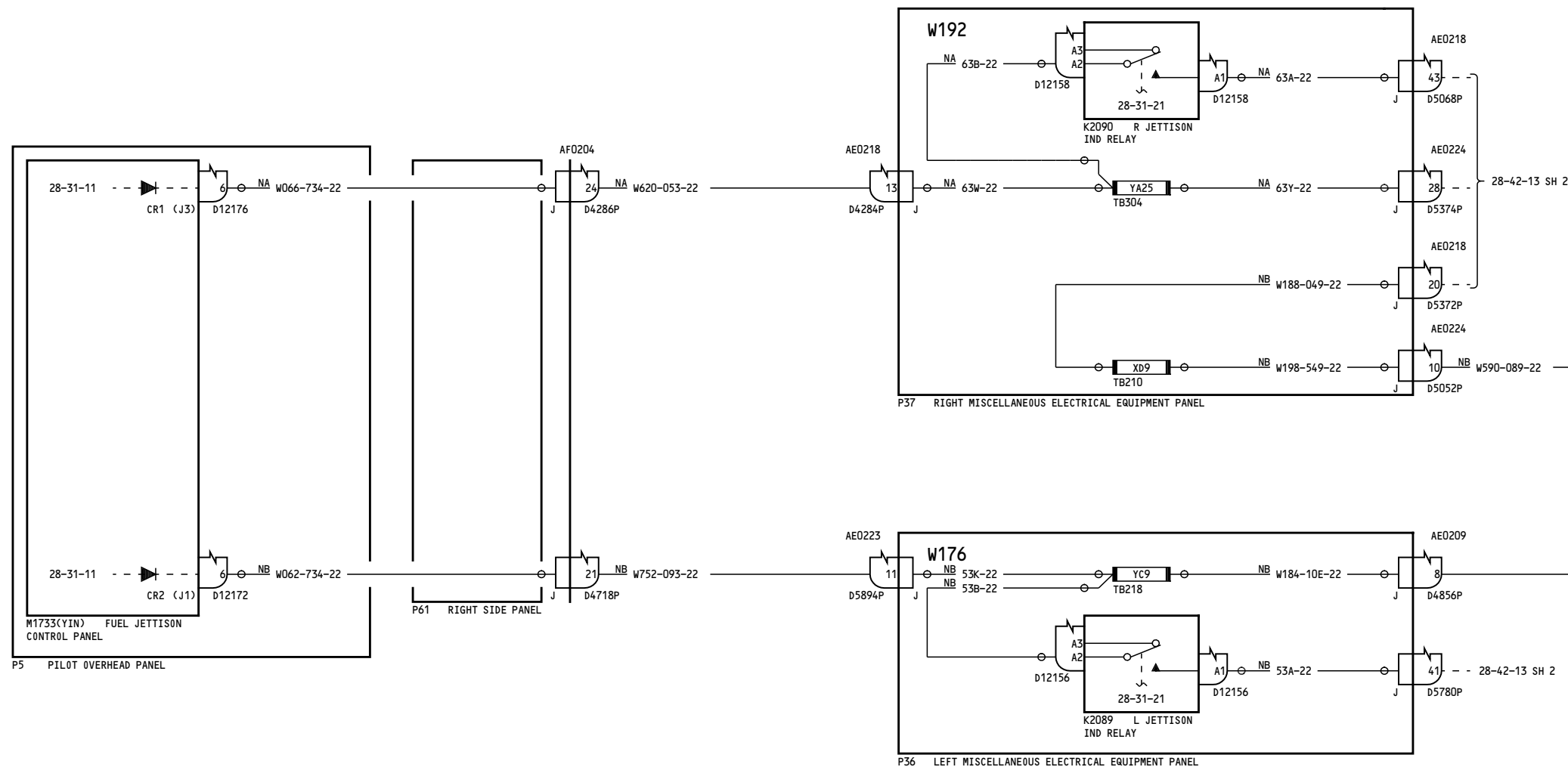

050-099, 162-164, 276

**FUEL JETTISON PUMPS LOW PRESSURE SWITCH**

D280T132

**28-42-13**

Page 1  
Sheet 1  
Jan 21/2005

**28-42-13**

Page 1  
Sheet 1  
Jan 21/2005



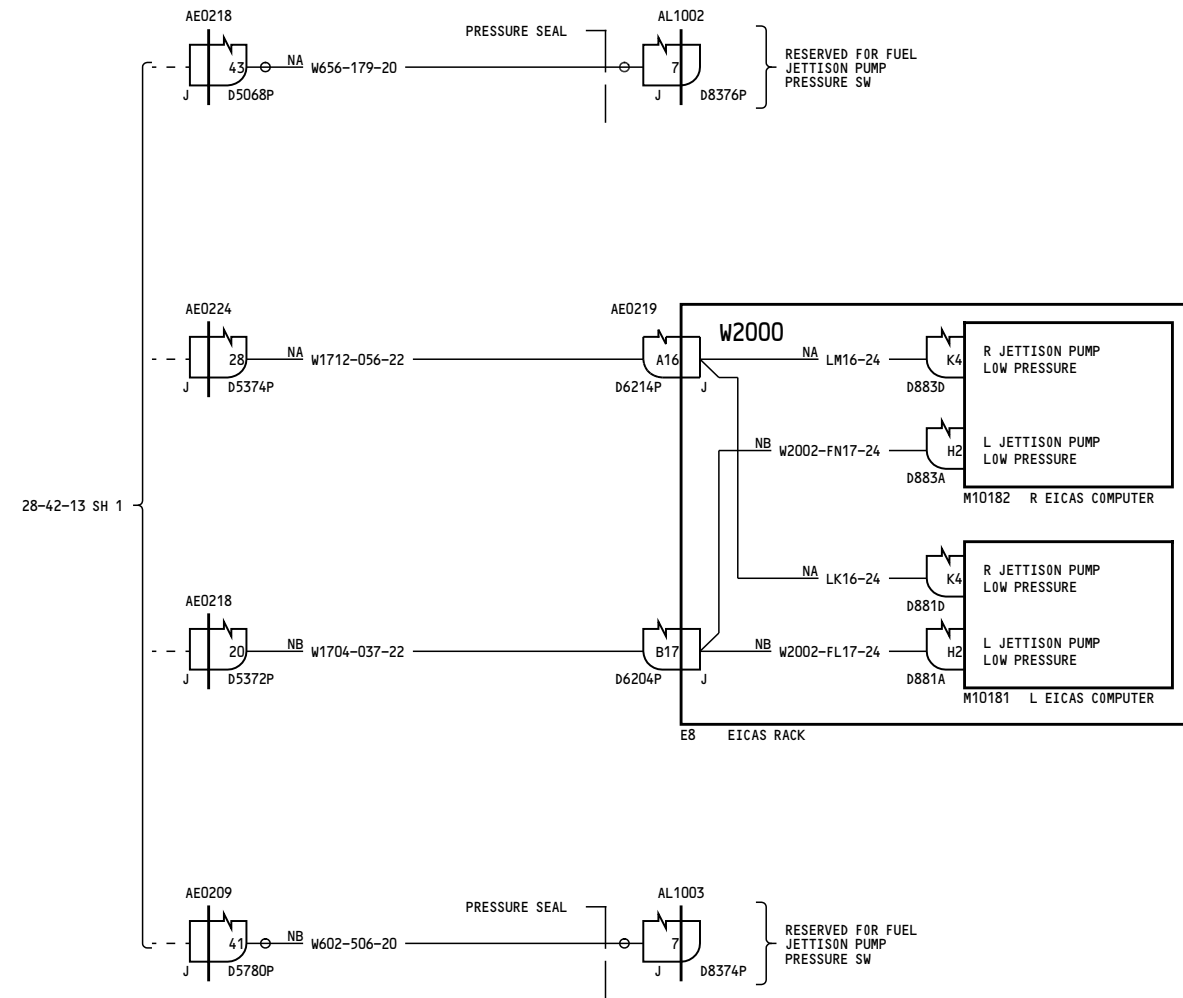

050-099, 162-164, 276

**FUEL JETTISON PUMPS LOW PRESSURE SWITCH**

D280T132

**28-42-13**

Page 1  
Sheet 2  
Jan 21/2005

**28-42-13**

Page 1  
Sheet 2  
Jan 21/2005

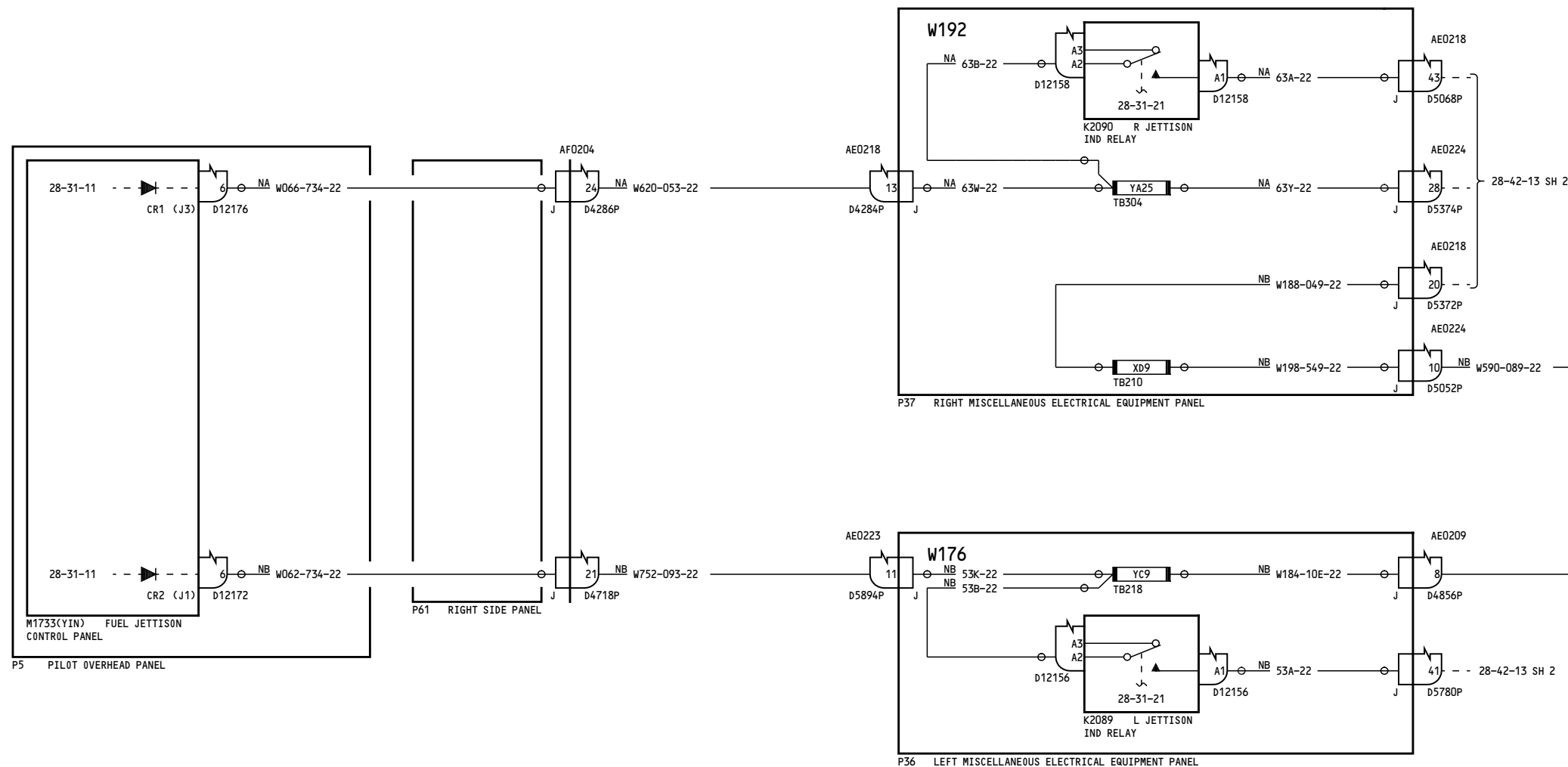

155-157, 165-199, 277-299

**FUEL JETTISON PUMPS LOW PRESSURE SWITCH**

D280T132

**28-42-13**

Page 2  
Sheet 1  
Jan 21/2005

**28-42-13**

Page 2  
Sheet 1  
Jan 21/2005

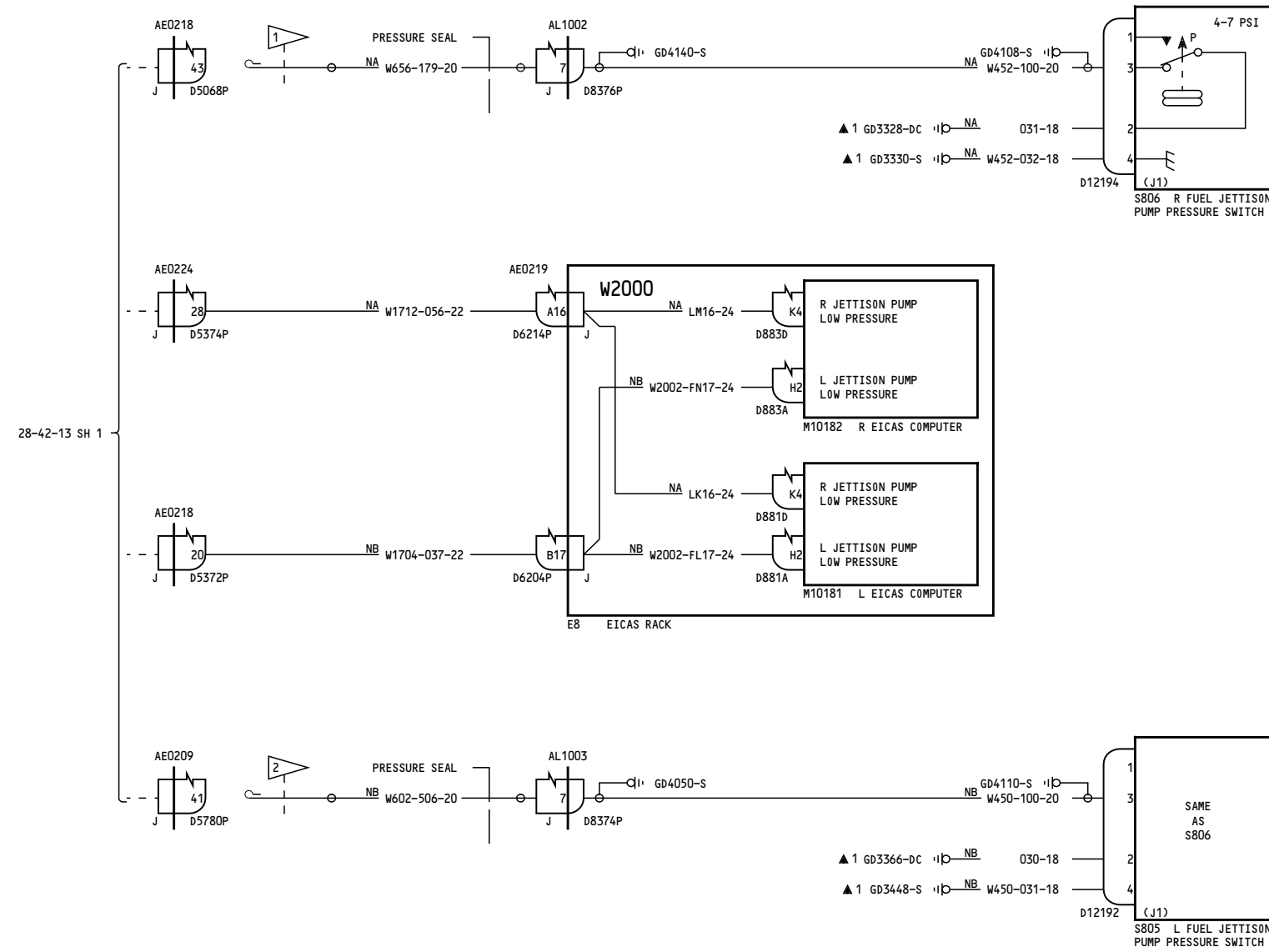

- NOTES:
- 1 CAP & STOW NEAR D5068P
  - 2 CAP & STOW NEAR D5780P

155-157, 165-199, 277-299

**FUEL JETTISON PUMPS LOW PRESSURE SWITCH**

D280T132

**28-42-13**

Page 2  
Sheet 2  
Jan 21/2005

**28-42-13**

Page 2  
Sheet 2  
Jan 21/2005

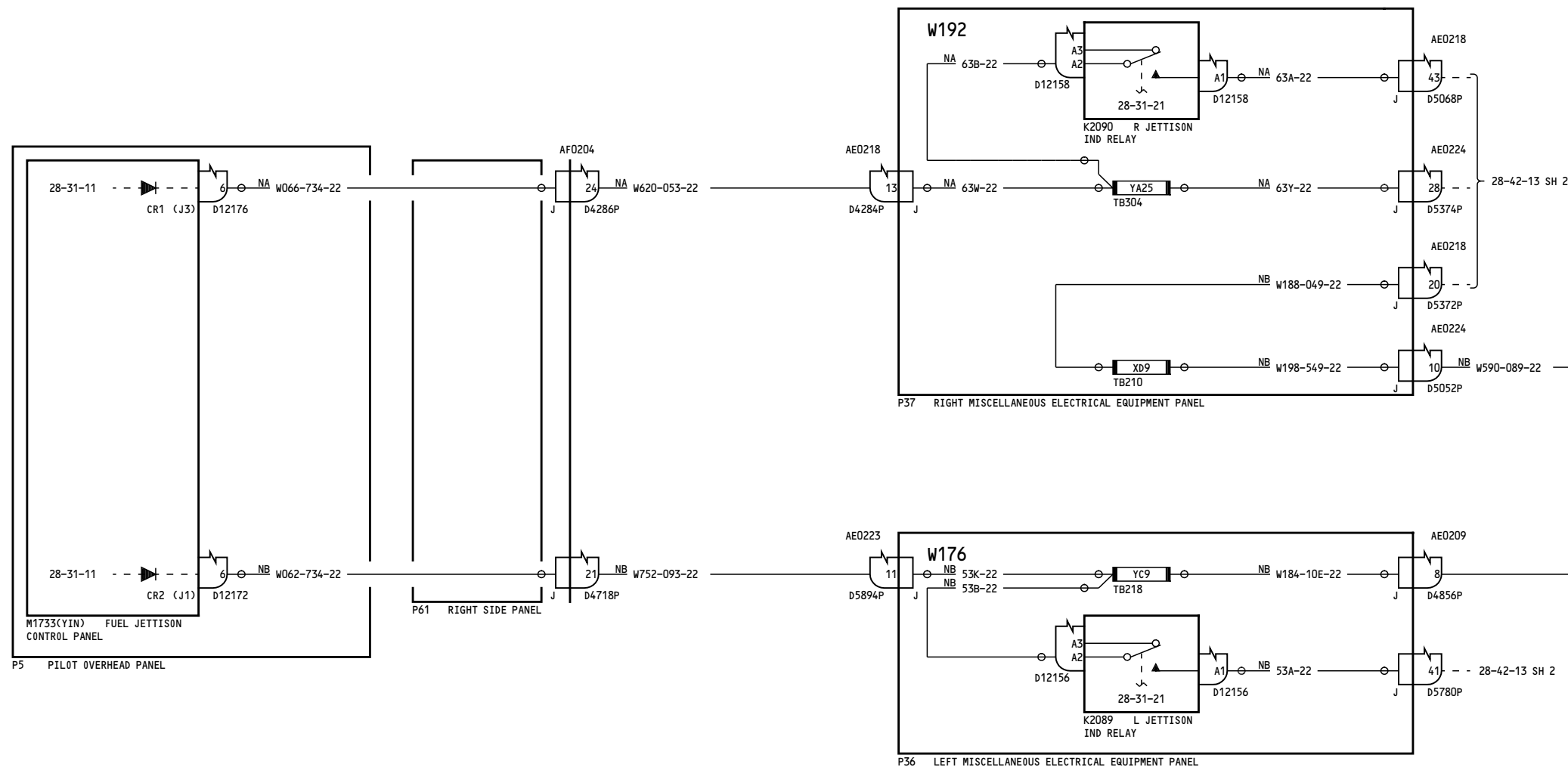

155-157, 165-167, 277-280

**FUEL JETTISON PUMPS LOW PRESSURE SWITCH**

D280T132

**28-42-13**

Page 2.1  
Sheet 1  
Jan 21/2005

**28-42-13**

Page 2.1  
Sheet 1  
Jan 21/2005

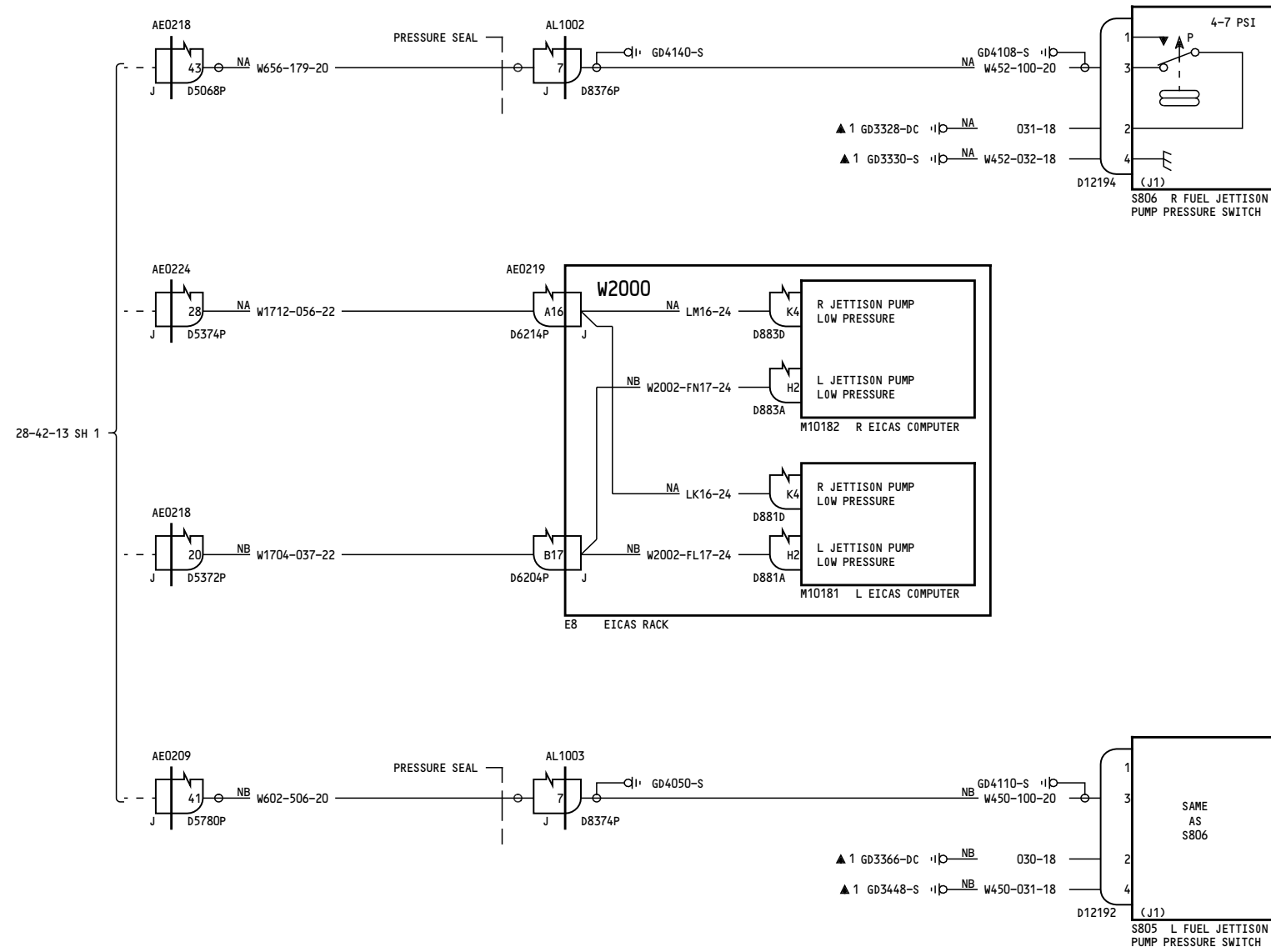

155-157, 165-167, 277-280

**FUEL JETTISON PUMPS LOW PRESSURE SWITCH**

D280T132

**28-42-13**

Page 2.1  
Sheet 2  
Jan 21/2005

Incorporates  
28-0038 R02

**28-42-13**

Page 2.1  
Sheet 2  
Jan 21/2005

-B

3

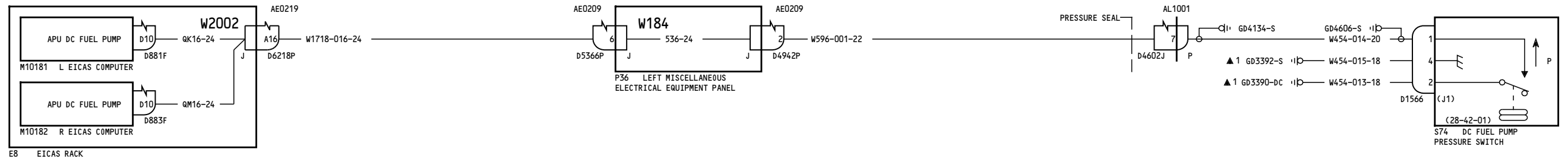

ALL

**FUEL PRESSURE INDICATOR-DC PUMP**

**28-42-21**

Page 1

D280T132

Jan 21/2005

**28-42-21**

Page 1

Jan 21/2005

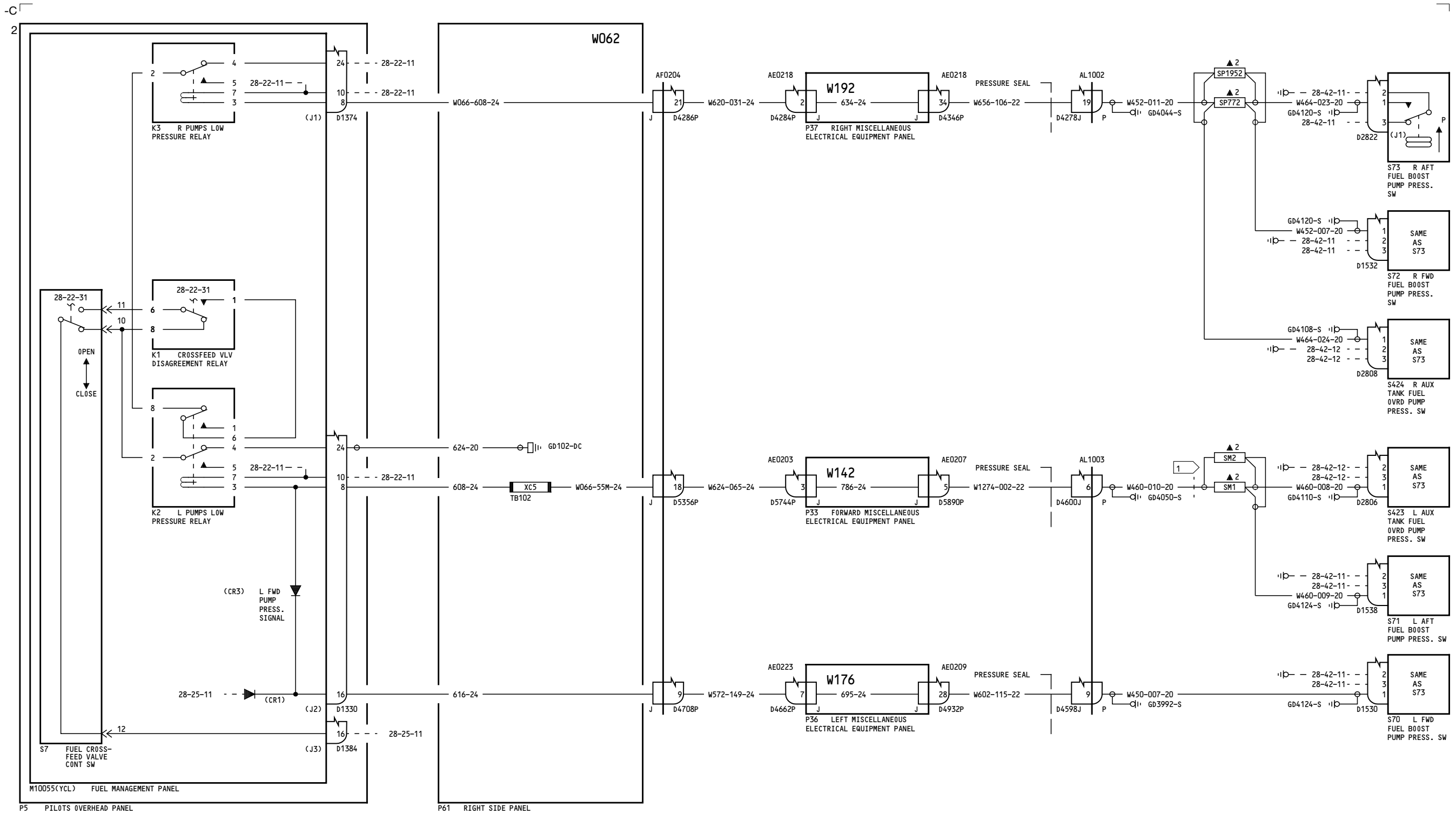

NOTES:  
 1 MAMIMUM LENGTH OF WIRE SHALL NOT EXCEED 12 INCHES

050-099, 150-154, 162-165, 275-276

**ENGINE FUEL LOW PRESSURE INDICATION**

**28-42-31**

Page 1

D280T132

Jan 21/2005

**28-42-31**

Page 1

Jan 21/2005

-A  
14

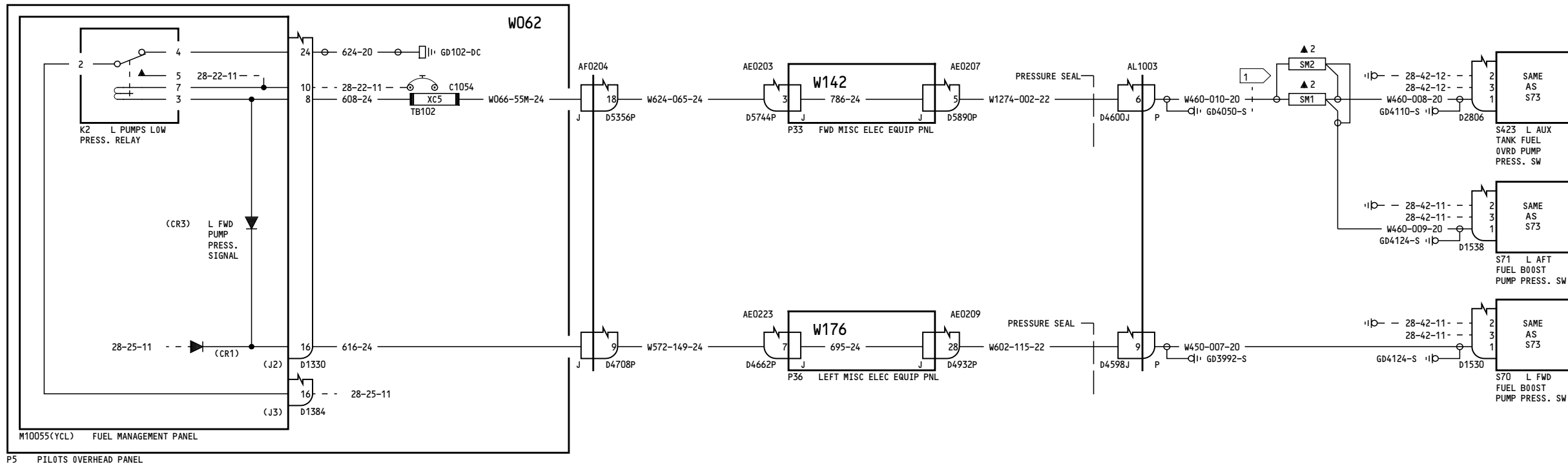

NOTES:  
① MAXIMUM LENGTH OF WIRE SHALL NOT EXCEED 12 INCHES

050-154, 162-165, 275-276	<b>ENGINE FUEL LOW PRESSURE INDICATION</b>
	D280T132

**28-42-31**

Page 1.1  
Jan 21/2005

Incorporates  
28-0034 R02

**28-42-31**

Page 1.1  
Jan 21/2005



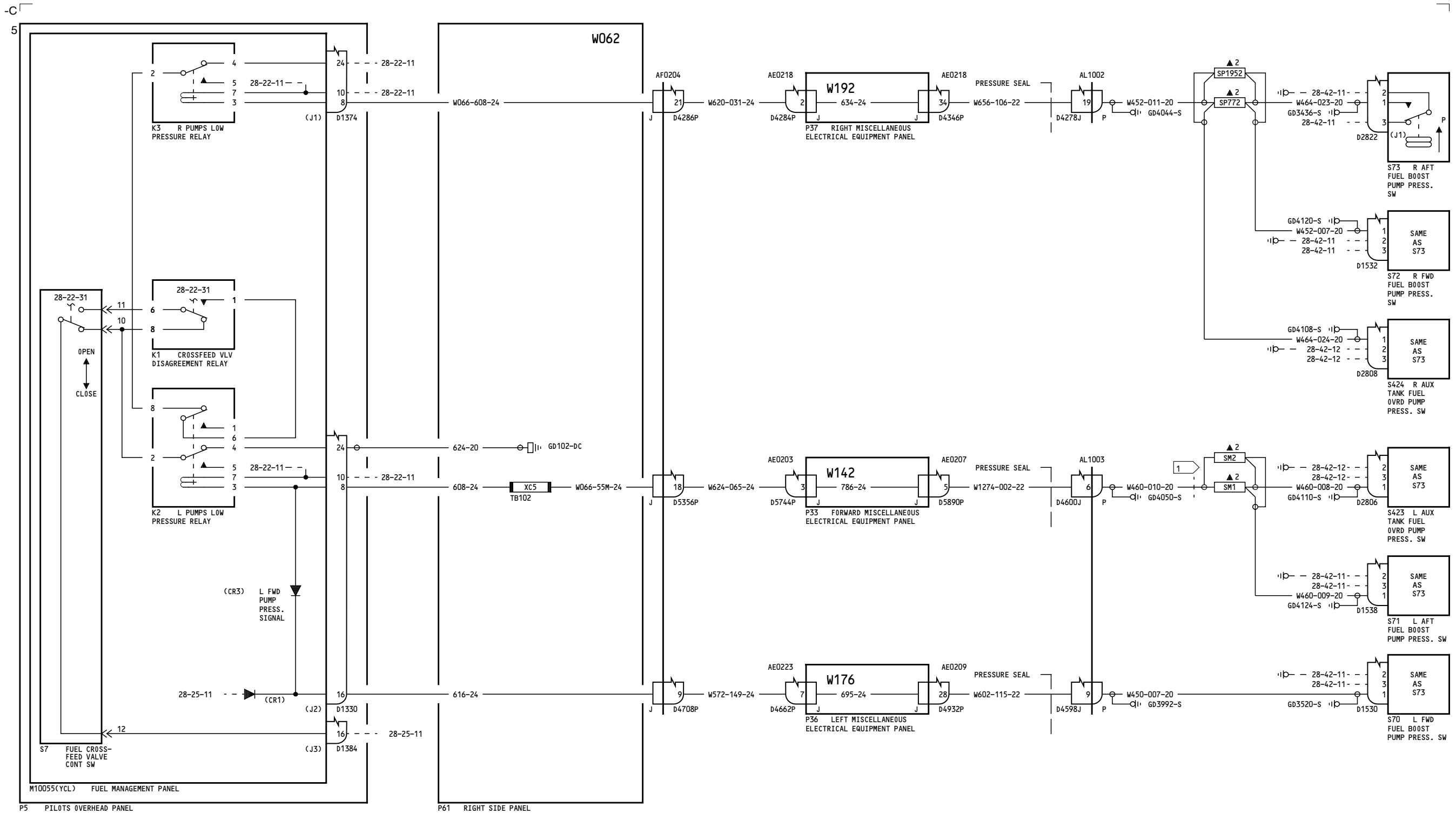

NOTES:  
 1 MAXIMUM LENGTH OF WIRE SHALL NOT EXCEED 12 INCHES

155-157, 166-199, 277-299

**ENGINE FUEL LOW PRESSURE INDICATION**

**28-42-31**

Page 2

D280T132

Jan 21/2005

**28-42-31**

Page 2

Jan 21/2005

-A

19

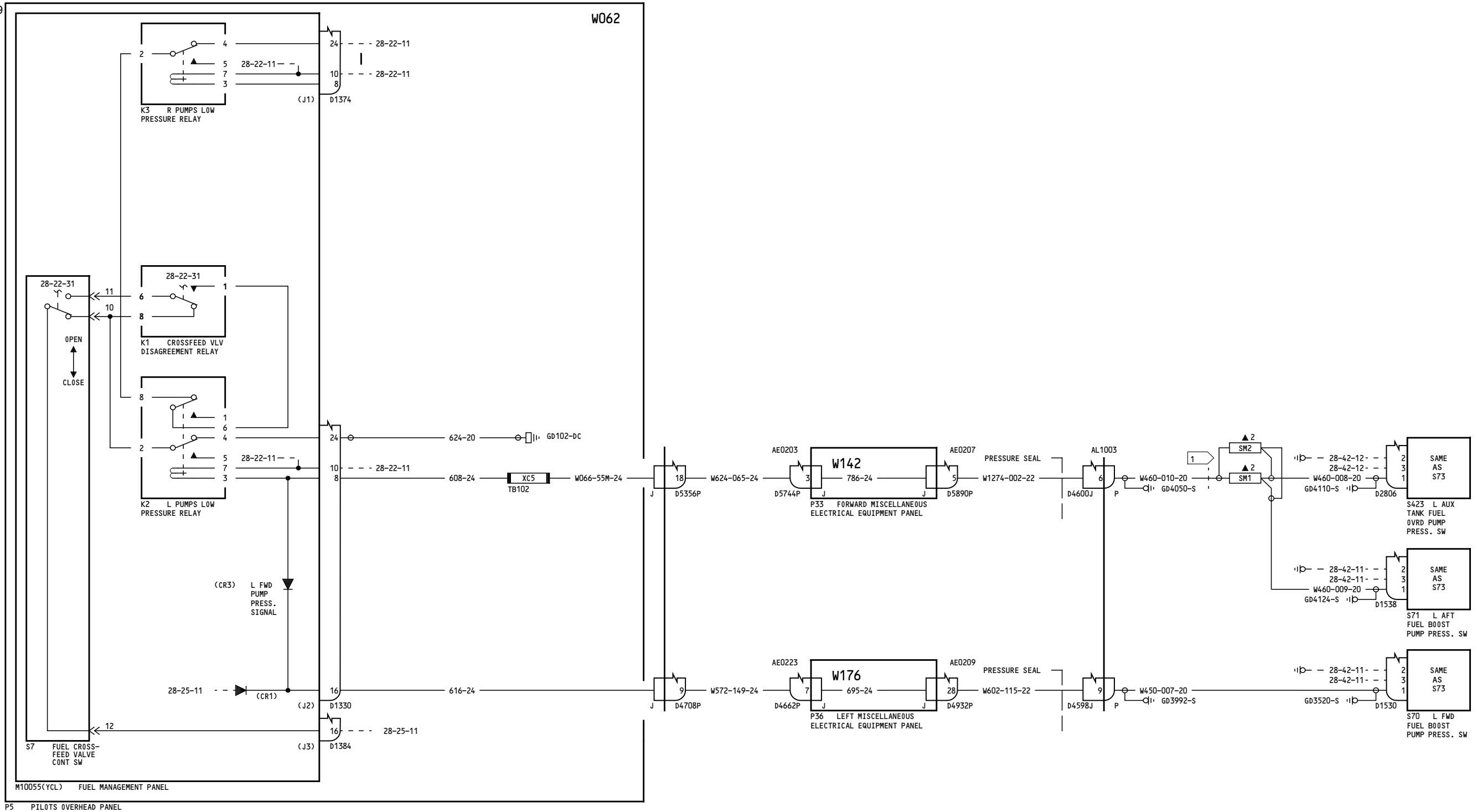

NOTES:  
 1 MAXIMUM LENGTH OF WIRE SHALL NOT EXCEED 12 INCHES

155-157, 166-167, 277-280

**ENGINE FUEL LOW PRESSURE INDICATION**

D280T132

**28-42-31**

Page 2.1  
 Jan 21/2005

Incorporates  
 28-0034 R02

**28-42-31**

Page 2.1  
 Jan 21/2005

-B

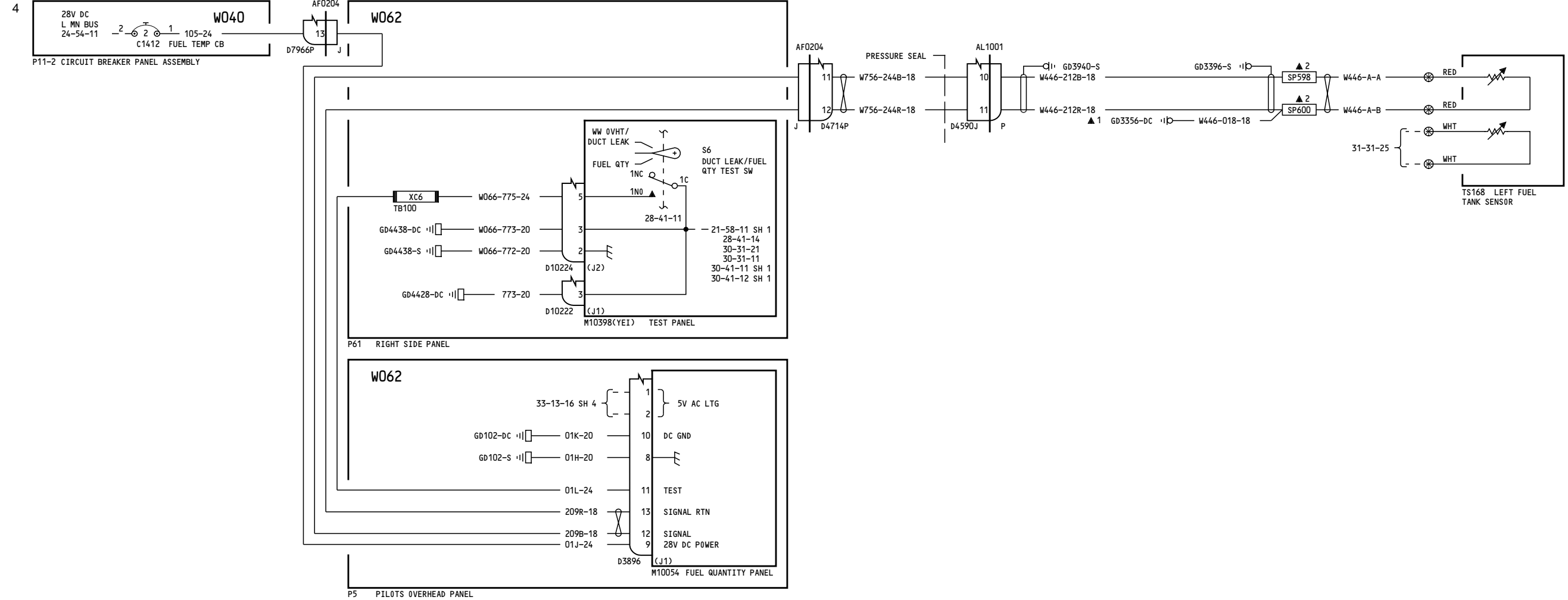

ALL	<b>FUEL TEMPERATURE INDICATION</b>
	D280T132

28-43-11

Page 1

Jan 21/2005

28-43-11

Page 1

Jan 21/2005