

CHAPTER

29

HYDRAULIC POWER



767-200/300

WIRING DIAGRAM MANUAL

CHAPTER 29
HYDRAULIC POWER

CH-SC-SU	Schem	Page	Sheet	Date	CH-SC-SU	Schem	Page	Sheet	Date
29-EFFECTIVE PAGES					29-33-11				
		1		Aug 05/2009		1.1	1		Jan 21/2005
		2		BLANK			2		Jan 21/2005
29-CONTENTS						2.1	1		Jan 21/2005
		1		Jun 28/2006			2		Jan 21/2005
		2		Jun 28/2006					
29-ALPHABETICAL INDEX									
		1		Jan 21/2005					
		2		BLANK					
29-11-11		1		Jan 21/2005					
		2		Jan 21/2005					
29-11-12		1	1	Jan 21/2005					
			2	Jan 21/2005					
			3	Jan 21/2005					
		2	1	Jan 21/2005					
			2	Jan 21/2005					
			3	Jan 21/2005					
29-11-14		1	1	Jan 21/2005					
			2	Jan 21/2005					
		2	1	Jan 21/2005					
			2	Jan 21/2005					
			2	Jan 21/2005					
29-11-21		1		Jan 21/2005					
29-11-22		1	1	Jan 21/2005					
			2	Jan 21/2005					
			3	Jan 21/2005					
29-11-31		1	1	Jan 21/2005					
			2	Jan 21/2005					
29-11-32		1	1	Jan 21/2005					
			2	Jan 21/2005					
			3	Jan 21/2005					
29-21-31		1	1	Jan 21/2005					
			2	Jan 21/2005					
29-21-32		1		Jan 21/2005					
29-31-11		1		Jan 21/2005					
		2		Jan 21/2005					
		3		Jan 21/2005					
29-32-11		1	1	Jan 21/2005					
			2	Jan 21/2005					
		2	1	Jan 21/2005					
			2	Jan 21/2005					

A = Added, R = Revised, D = Deleted, O = Overflow

29-EFFECTIVE PAGES

Page 1
Aug 05/2009

D280T132



767-200/300

WIRING DIAGRAM MANUAL

CHAPTER 29
HYDRAULIC POWER

Title	CH-SC-SU	Schem	Page	Sheet	Date	Effectivity
MAIN (LEFT, RIGHT, AND CENTER) HYDRAULIC SYSTEMS						
ENGINE HYDRAULIC PUMP- LEFT SHUTOFF & DEPRESS	29-11-11		1		Jan 21/2005	050-099 150-162 275-299
			2		Jan 21/2005	163-199
ELECTRIC HYDRAULIC PUMP LEFT CONTROL & INDICATION	29-11-12		1	1	Jan 21/2005	050-099 155-199 276-299
			2		Jan 21/2005	050-099 155-199 276-299
			3		Jan 21/2005	050-099 155-199 276-299
			2	1	Jan 21/2005	150-154 275
			2		Jan 21/2005	150-154 275
			3		Jan 21/2005	150-154 275
HYDRAULIC POWER TRANSFER UNIT	29-11-14		1	1	Jan 21/2005	050-099
			2		Jan 21/2005	050-099
			2	1	Jan 21/2005	150-199 275-299
			2		Jan 21/2005	150-199 275-299
ENGINE HYDRAULIC PUMP RIGHT SHUTOFF AND DEPRESS	29-11-21		1		Jan 21/2005	ALL
ELECTRIC HYDRAULIC PUMP RIGHT CONTROL & INDICATION	29-11-22		1	1	Jan 21/2005	ALL
			2		Jan 21/2005	ALL
			3		Jan 21/2005	ALL
ELECTRIC HYDRAULIC PUMPS 1 & 2 CONTROL & INDICATION	29-11-31		1	1	Jan 21/2005	ALL
			2		Jan 21/2005	ALL
AIR HYDRAULIC PUMP CONTROL & INDICATION	29-11-32		1	1	Jan 21/2005	ALL
			2		Jan 21/2005	ALL
			3		Jan 21/2005	ALL
RAM AIR TURBINE (RAT) SYSTEM						
RAM AIR TURBINE CONTROL & INDICATION HYDRAULIC SYSTEM CENTER	29-21-31		1	1	Jan 21/2005	ALL

29-CONTENTS

Page 1
Jun 28/2006

D280T132



767-200/300

WIRING DIAGRAM MANUAL

**CHAPTER 29
HYDRAULIC POWER**

Title	CH-SC-SU	Schem	Page	Sheet	Date	Effectivity
RAM AIR TURBINE CONTROL & INDICATION HYDRAULIC SYSTEM CENTER (cont.)	29-21-31			2	Jan 21/2005	ALL
RESERVE HYDRAULIC SOURCE SELECT & INDICATION	29-21-32		1		Jan 21/2005	ALL
<u>HYDRAULIC INDICATING SYSTEM</u>						
HYDRAULIC FLUID PRESSURE INDICATOR SYSTEM	29-31-11		1		Jan 21/2005	050-099
			2		Jan 21/2005	150-154 162-164 275-276
			3		Jan 21/2005	155-157 165-199 277-299
<u>HYDRAULIC FLUID TEMPERATURE INDICATING SYSTEM</u>						
HYDRAULIC FLUID TEMPERATURE INDICATION SYSTEM	29-32-11		1	1	Jan 21/2005	050-099 150-199 275-278
				2	Jan 21/2005	050-099 150-199 275-278
			2	1	Jan 21/2005	280-299
				2	Jan 21/2005	280-299
<u>HYDRAULIC FLUID QUANTITY INDICATING SYSTEM</u>						
HYDRAULIC FLUID QUANTITY INDICATION SYSTEM	29-33-11		1.1	1	Jan 21/2005	050-051 275-280
				2	Jan 21/2005	050-051 275-280
			2.1	1	Jan 21/2005	150-167
				2	Jan 21/2005	150-167



767-200/300

WIRING DIAGRAM MANUAL

CHAPTER 29 HYDRAULIC POWER

CH-SC-SU	Title
29-11-32	AIR HYDRAULIC PUMP CONTROL & INDICATION
29-11-12	ELECTRIC HYDRAULIC PUMP LEFT CONTROL & INDICATION
29-11-22	ELECTRIC HYDRAULIC PUMP RIGHT CONTROL & INDICATION
29-11-31	ELECTRIC HYDRAULIC PUMPS 1 & 2 CONTROL & INDICATION
29-11-21	ENGINE HYDRAULIC PUMP RIGHT SHUTOFF AND DEPRESS
29-11-11	ENGINE HYDRAULIC PUMP- LEFT SHUTOFF & DEPRESS
29-31-11	HYDRAULIC FLUID PRESSURE INDICATOR SYSTEM
29-33-11	HYDRAULIC FLUID QUANTITY INDICATION SYSTEM
29-32-11	HYDRAULIC FLUID TEMPERATURE INDICATION SYSTEM
29-11-14	HYDRAULIC POWER TRANSFER UNIT
29-21-31	RAM AIR TURBINE CONTROL & INDICATION HYDRAULIC SYSTEM CENTER
29-21-32	RESERVE HYDRAULIC SOURCE SELECT & INDICATION

29-ALPHABETICAL INDEX

D280T132

Page 1
Jan 21/2005

13

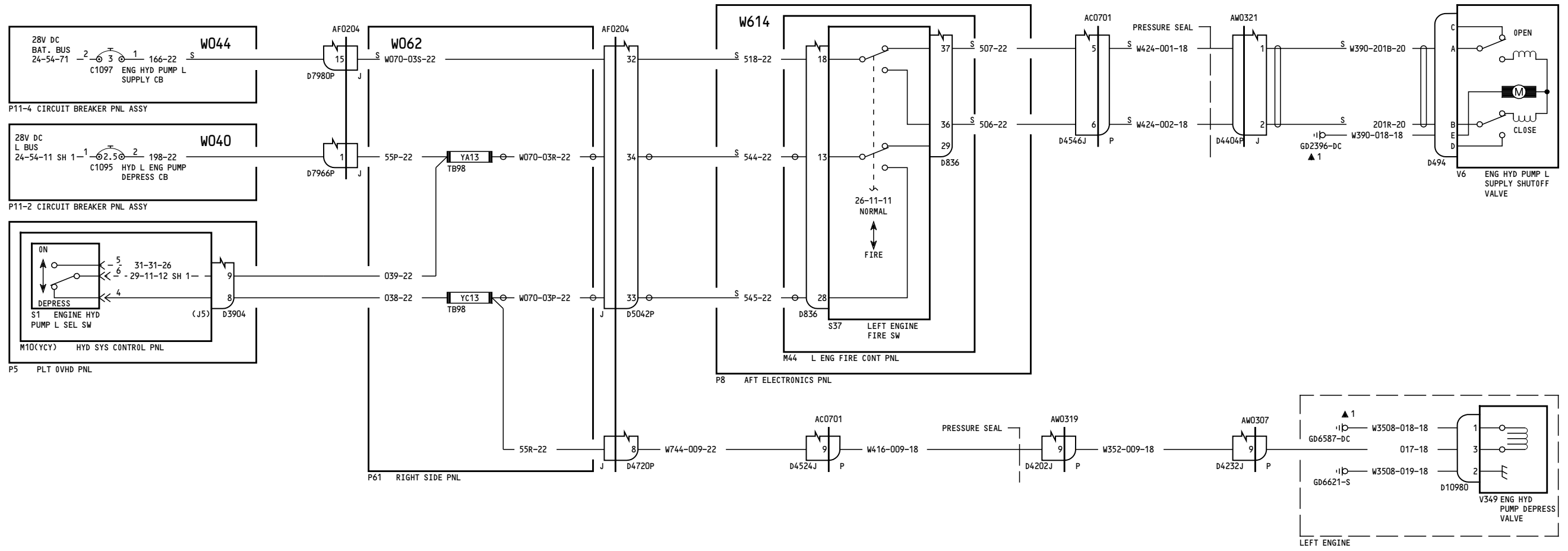

050-099, 150-162, 275-299

**ENGINE HYDRAULIC PUMP-
LEFT SHUTOFF & DEPRESS**

29-11-11

Page 1

Jan 21/2005

D280T132

29-11-11

Page 1

Jan 21/2005

18

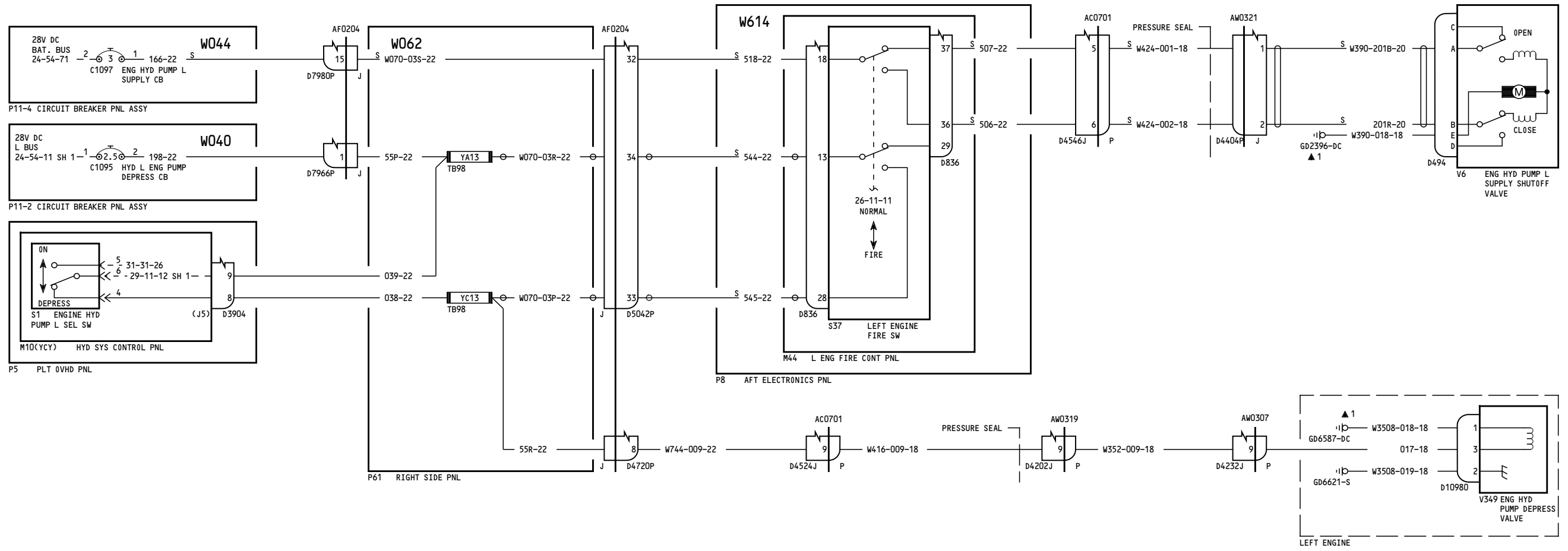

163-199

**ENGINE HYDRAULIC PUMP-
LEFT SHUTOFF & DEPRESS**

29-11-11

Page 2

Jan 21/2005

D280T132

29-11-11

Page 2

Jan 21/2005

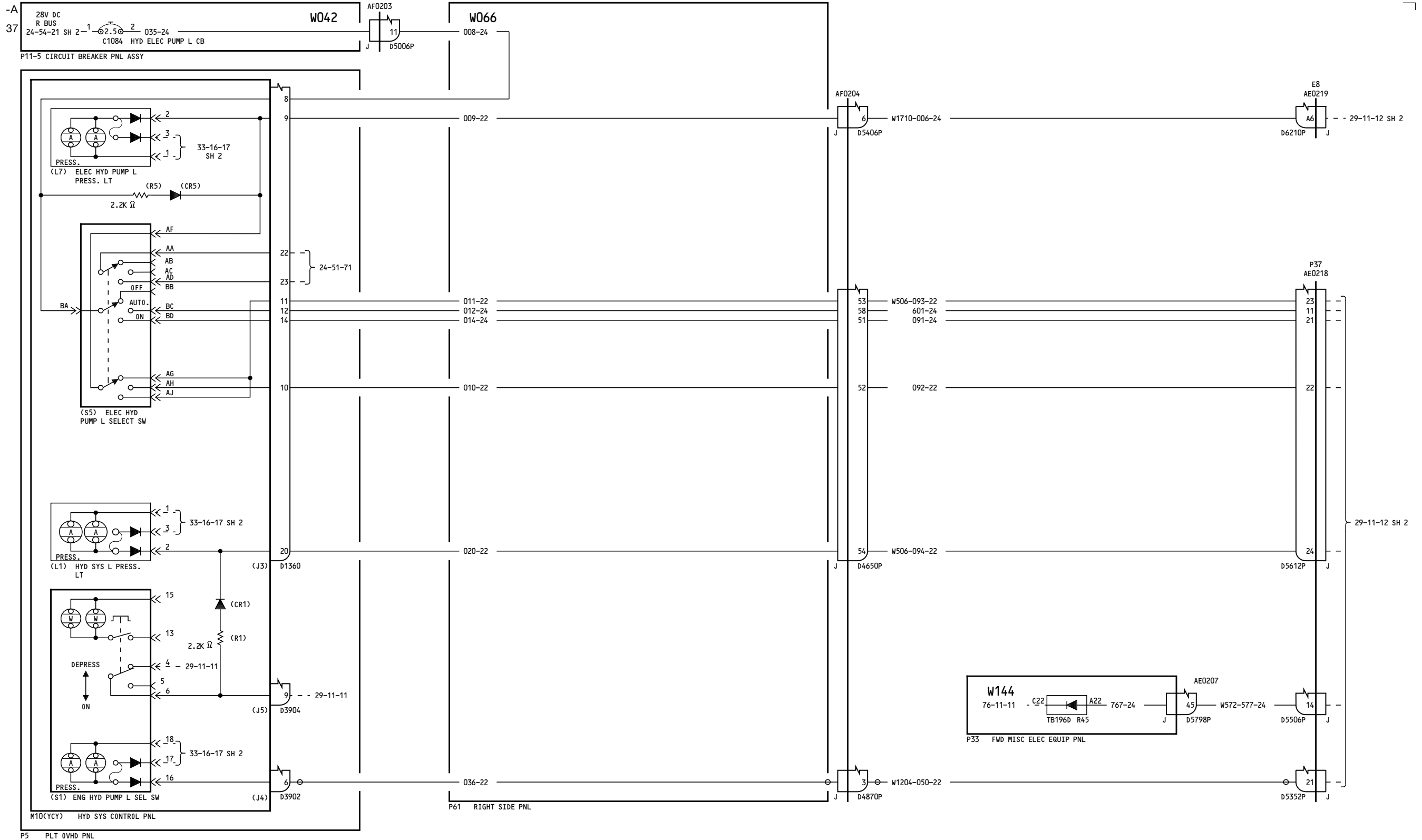

050-099, 155-199, 276-299

ELECTRIC HYDRAULIC PUMP LEFT CONTROL & INDICATION

29-11-12

Page 1
Sheet 1
Jan 21/2005

D280T132

29-11-12

Page 1
Sheet 1
Jan 21/2005

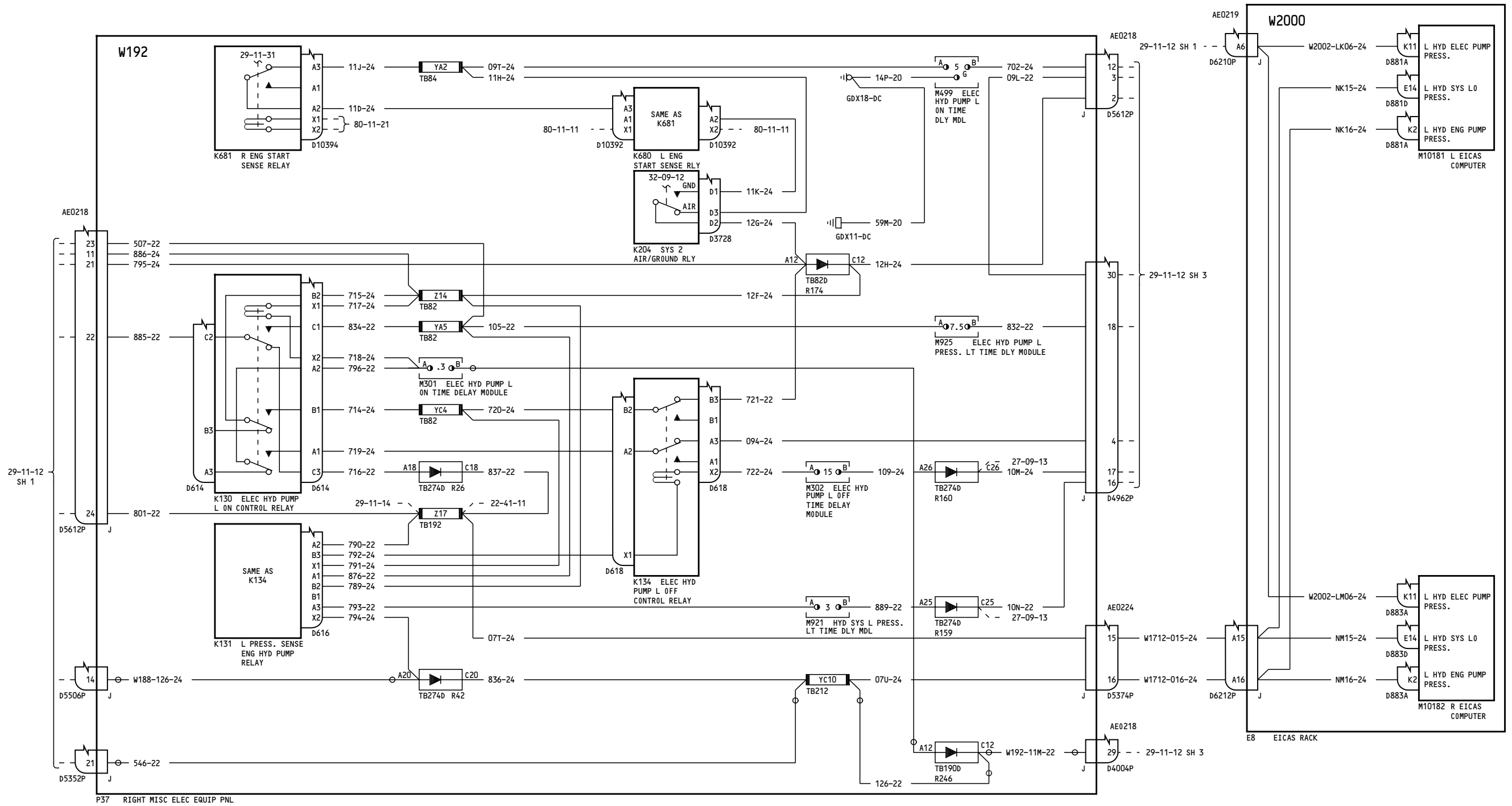

050-099, 155-199, 276-299

**ELECTRIC HYDRAULIC PUMP
LEFT CONTROL & INDICATION**

29-11-12

Page 1
Sheet 2
Jan 21/2005

D280T132

29-11-12

Page 1
Sheet 2
Jan 21/2005

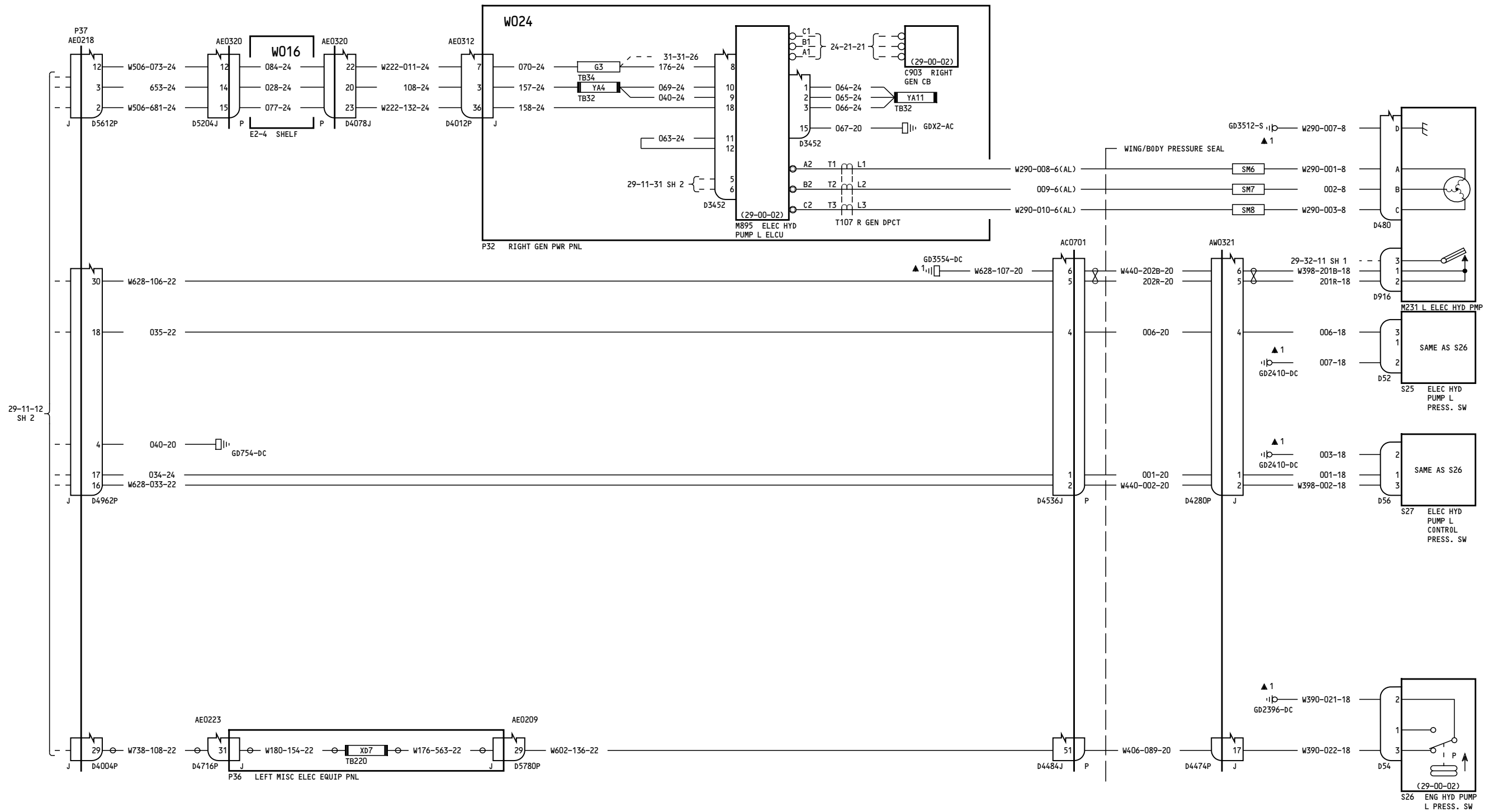

050-099, 155-199, 276-299

**ELECTRIC HYDRAULIC PUMP
LEFT CONTROL & INDICATION**

29-11-12
Page 1
Sheet 3
Jan 21/2005

D280T132

29-11-12
Page 1
Sheet 3
Jan 21/2005

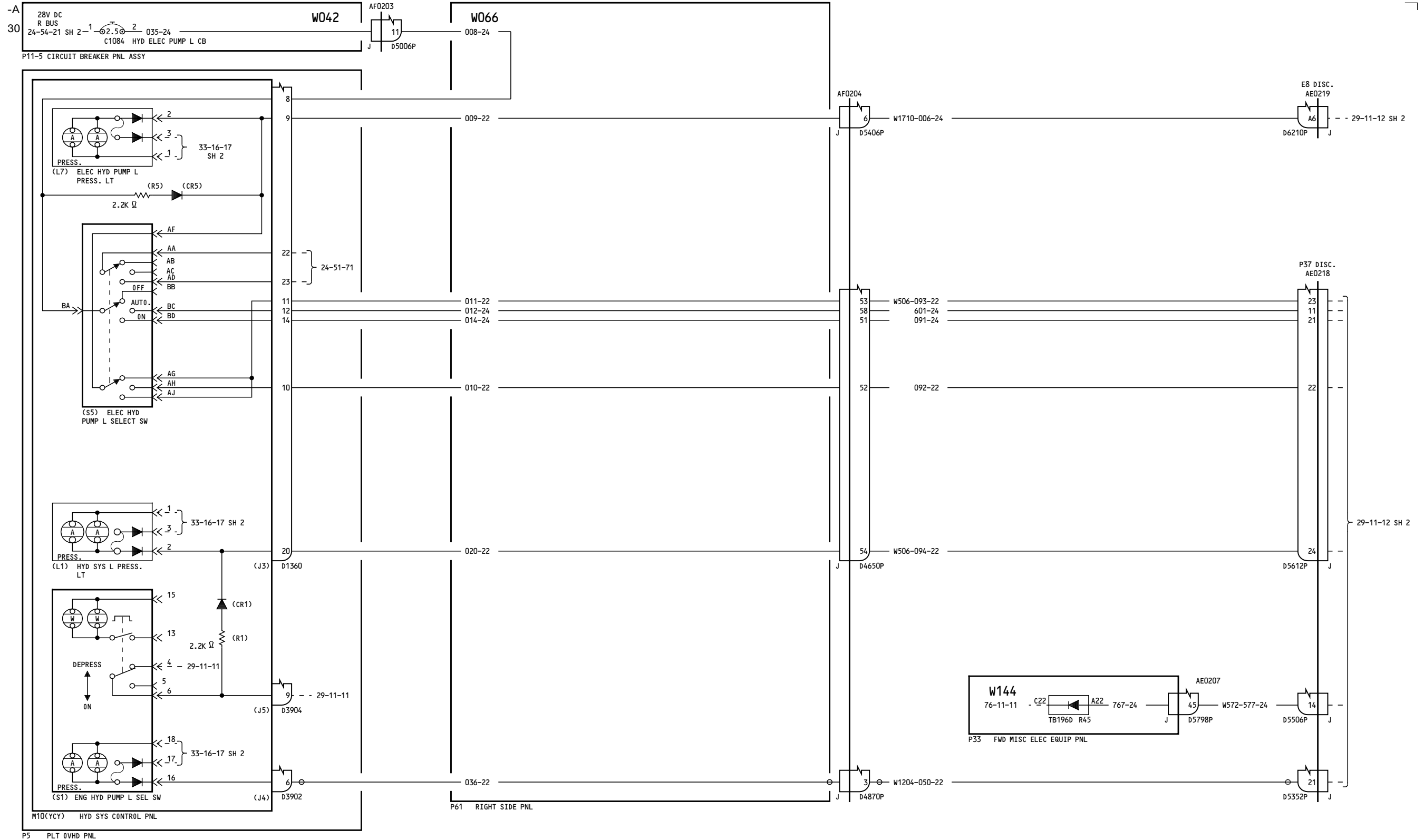

150-154, 275

**ELECTRIC HYDRAULIC PUMP
LEFT CONTROL & INDICATION**

29-11-12

Page 2
Sheet 1
Jan 21/2005

D280T132

29-11-12

Page 2
Sheet 1
Jan 21/2005

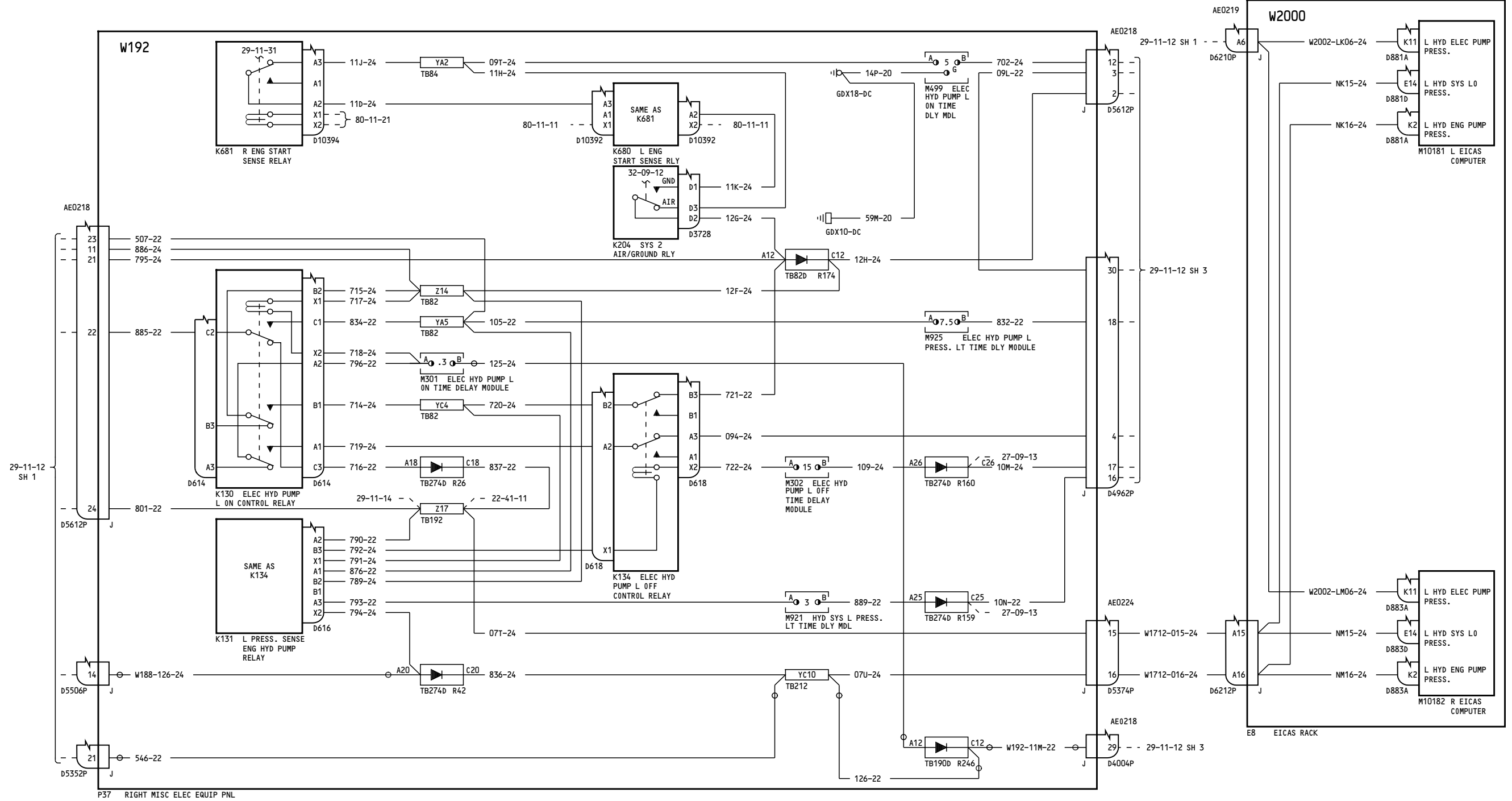

150-154, 275

**ELECTRIC HYDRAULIC PUMP
LEFT CONTROL & INDICATION**

29-11-12

Page 2
Sheet 2
Jan 21/2005

D280T132

29-11-12

Page 2
Sheet 2
Jan 21/2005

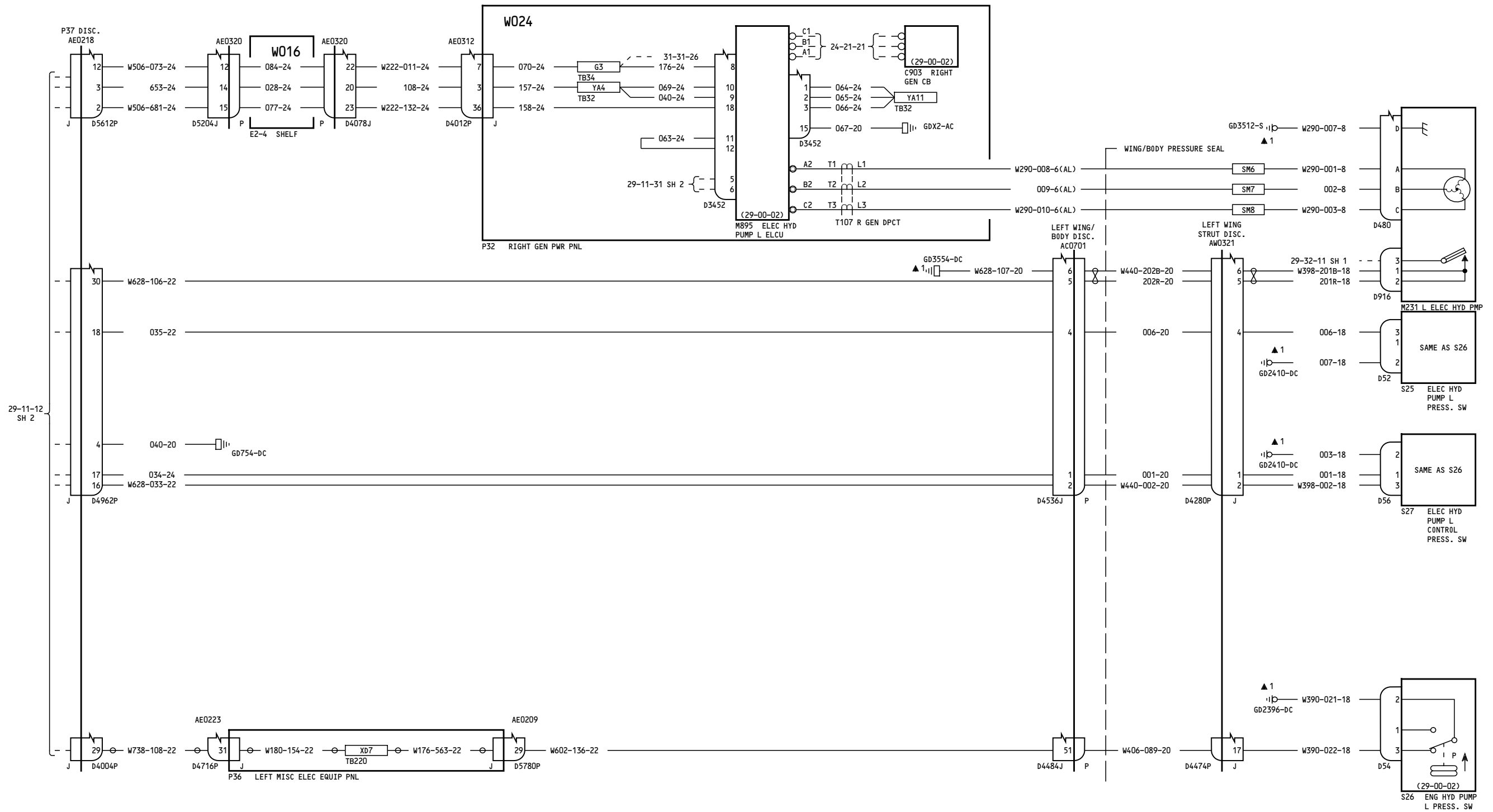

150-154, 275

**ELECTRIC HYDRAULIC PUMP
LEFT CONTROL & INDICATION**

D280T132

29-11-12

Page 2
Sheet 3
Jan 21/2005

29-11-12

Page 2
Sheet 3
Jan 21/2005

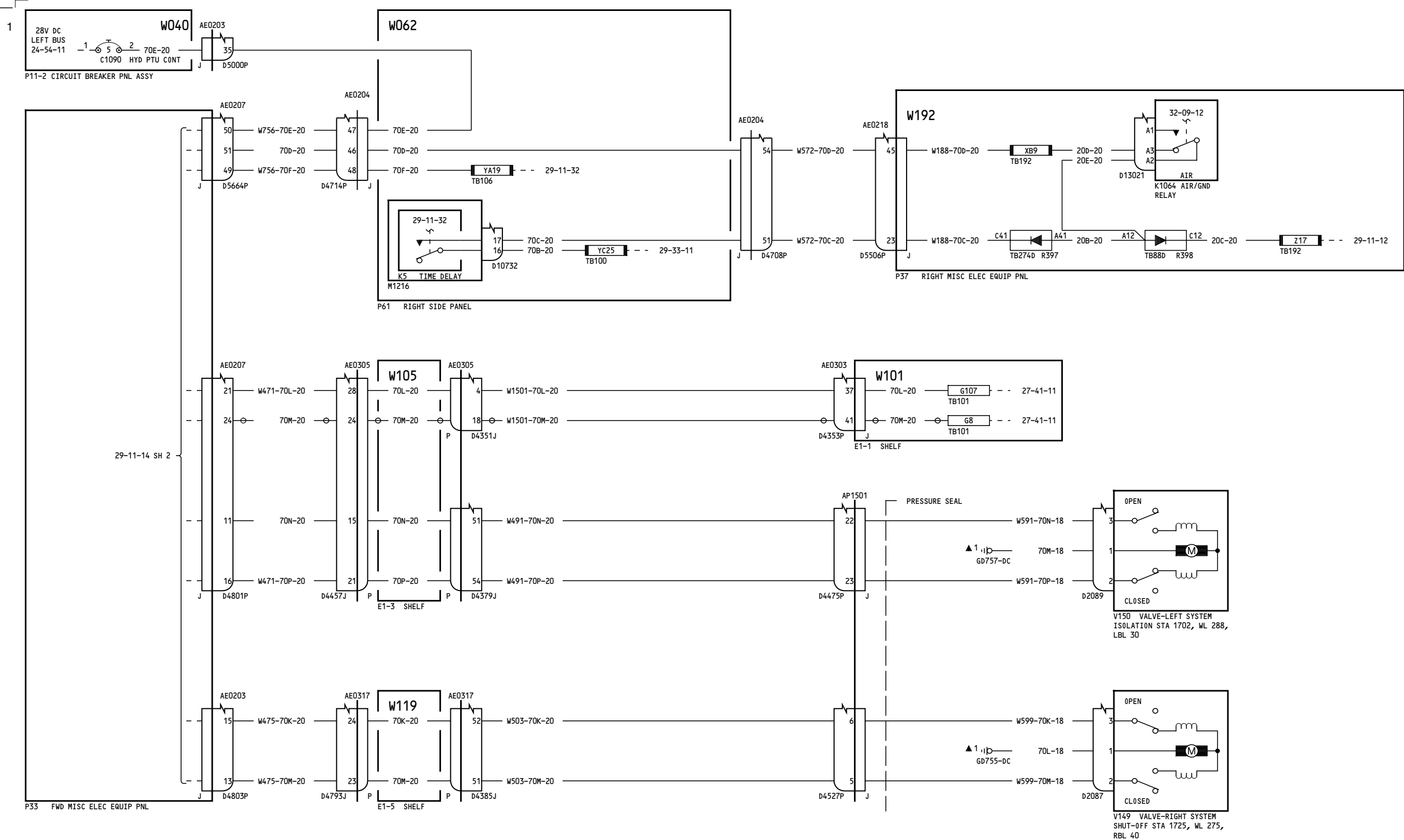

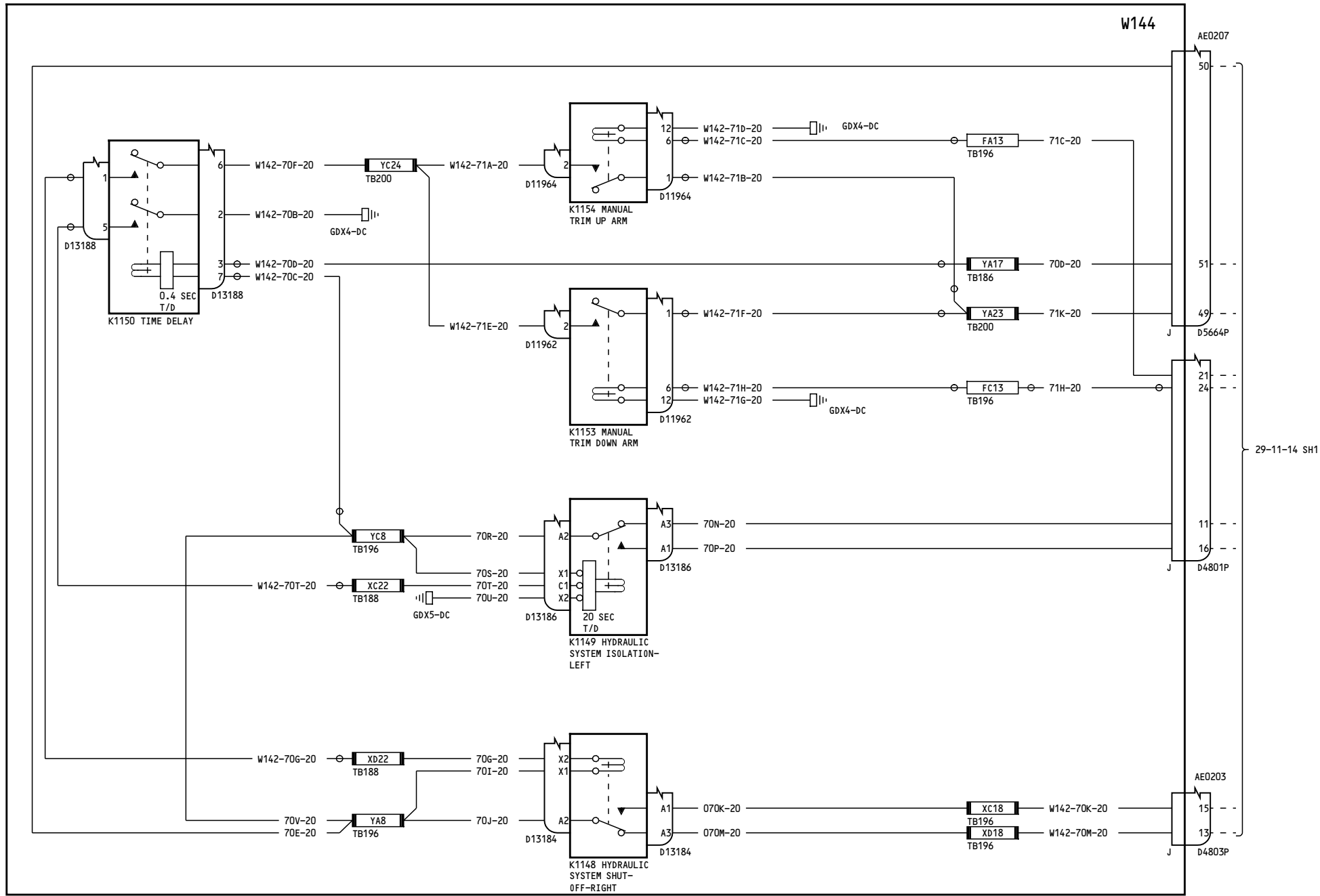

P33 MISC E/E EQUIP-FWD

050-099

HYDRAULIC POWER TRANSFER UNIT

D280T132

29-11-14

Page 1
Sheet 2
Jan 21/2005

29-11-14

Page 1
Sheet 2
Jan 21/2005

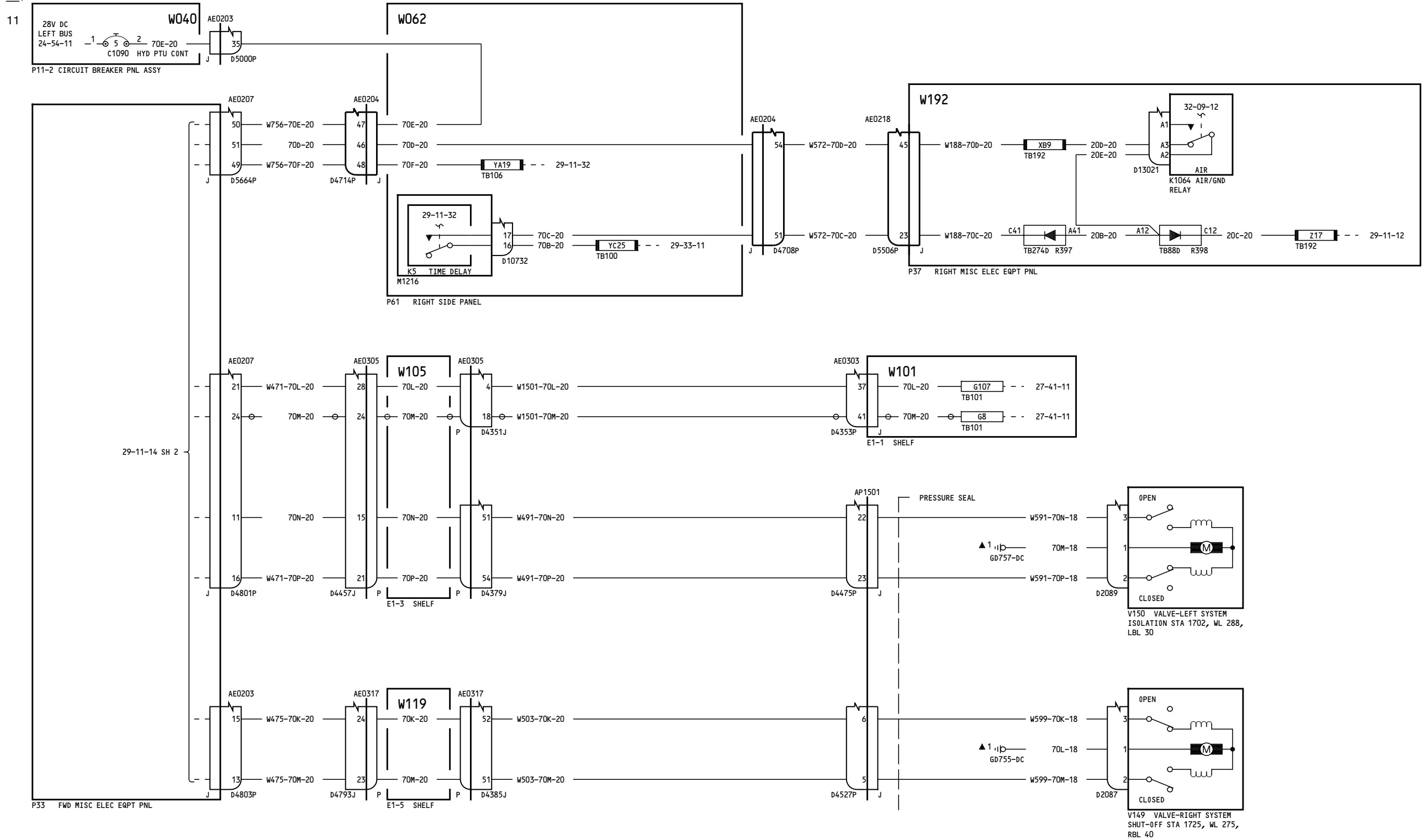

150-199, 275-299

HYDRAULIC POWER TRANSFER UNIT

D280T132

29-11-14

Page 2
Sheet 1
Jan 21/2005

29-11-14

Page 2
Sheet 1
Jan 21/2005

11

W144

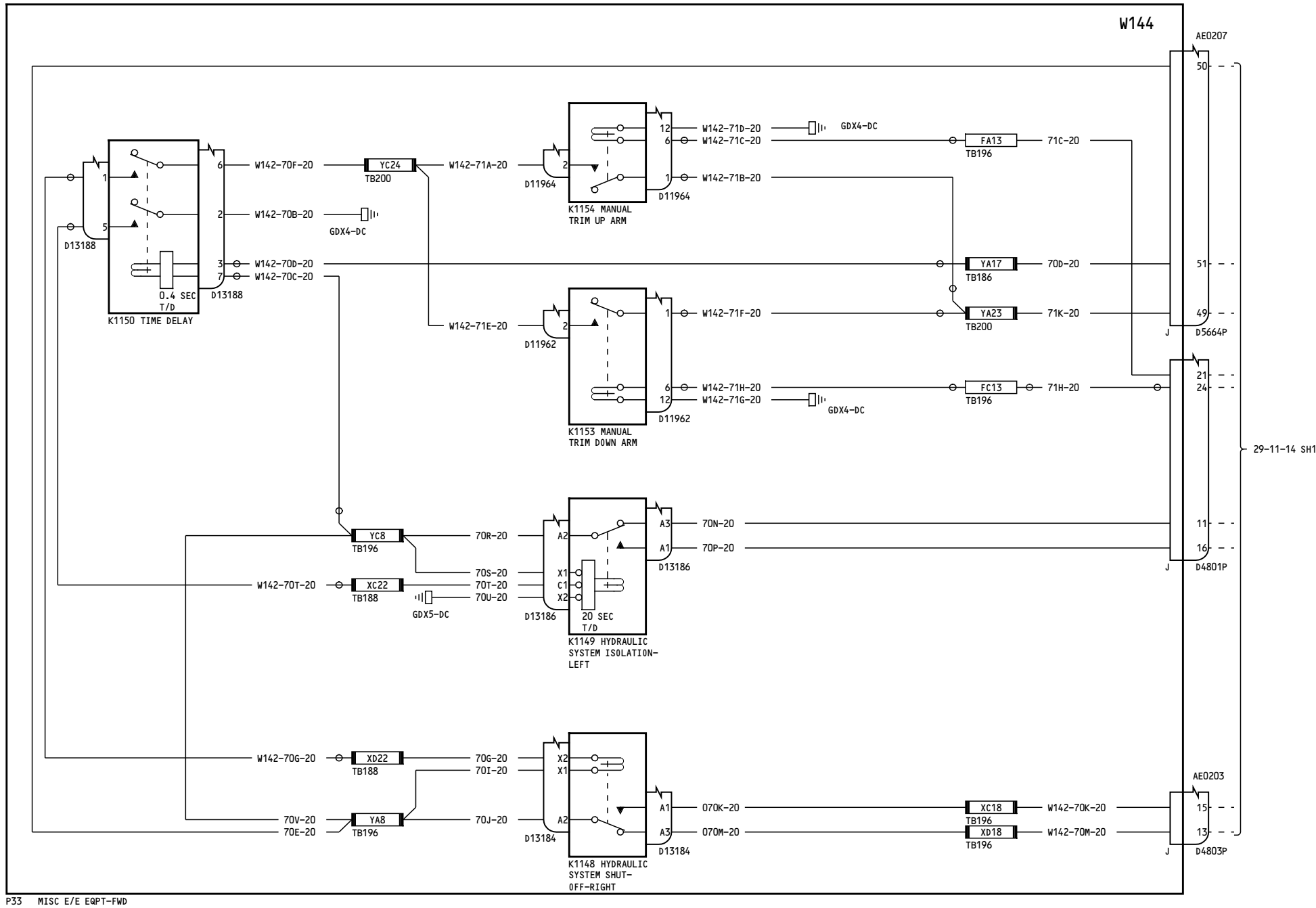

P33 MISC E/E EQPT-FWD

150-199, 275-299

HYDRAULIC POWER TRANSFER UNIT

D280T132

29-11-14

Page 2
Sheet 2
Jan 21/2005

29-11-14

Page 2
Sheet 2
Jan 21/2005

13

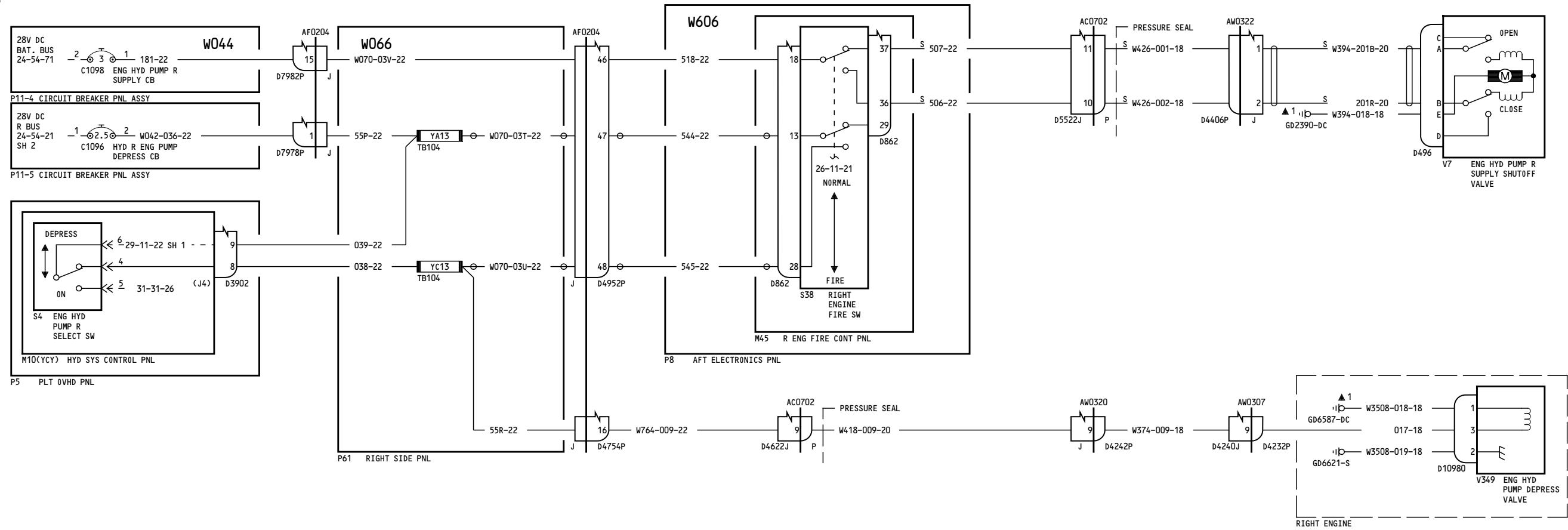

ALL

**ENGINE HYDRAULIC PUMP
RIGHT SHUTOFF AND DEPRESS**

29-11-21

Page 1

Jan 21/2005

D280T132

29-11-21

Page 1

Jan 21/2005

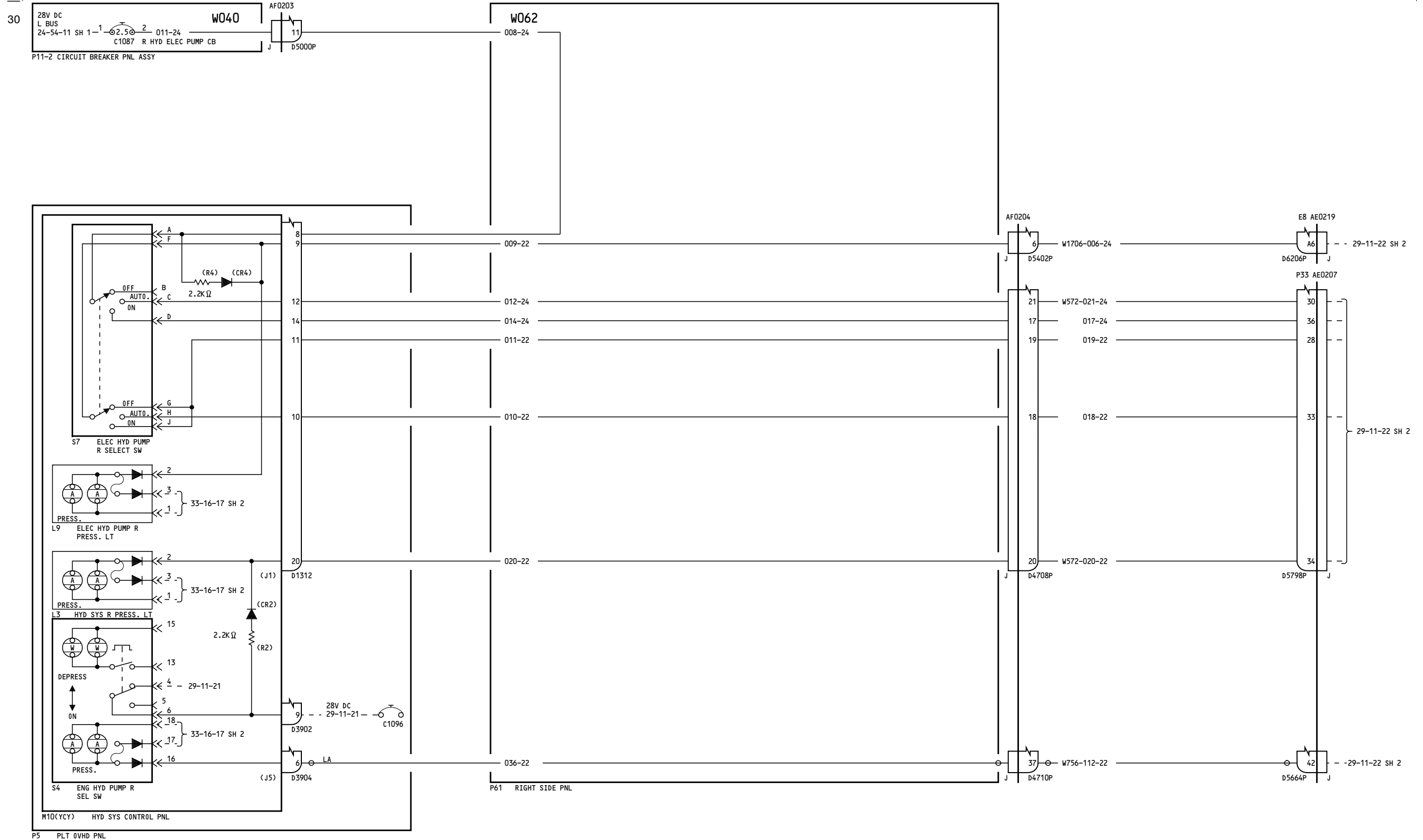

ALL

**ELECTRIC HYDRAULIC PUMP
RIGHT CONTROL &
INDICATION**

D280T132

29-11-22

Page 1
Sheet 1
Jan 21/2005

29-11-22

Page 1
Sheet 1
Jan 21/2005

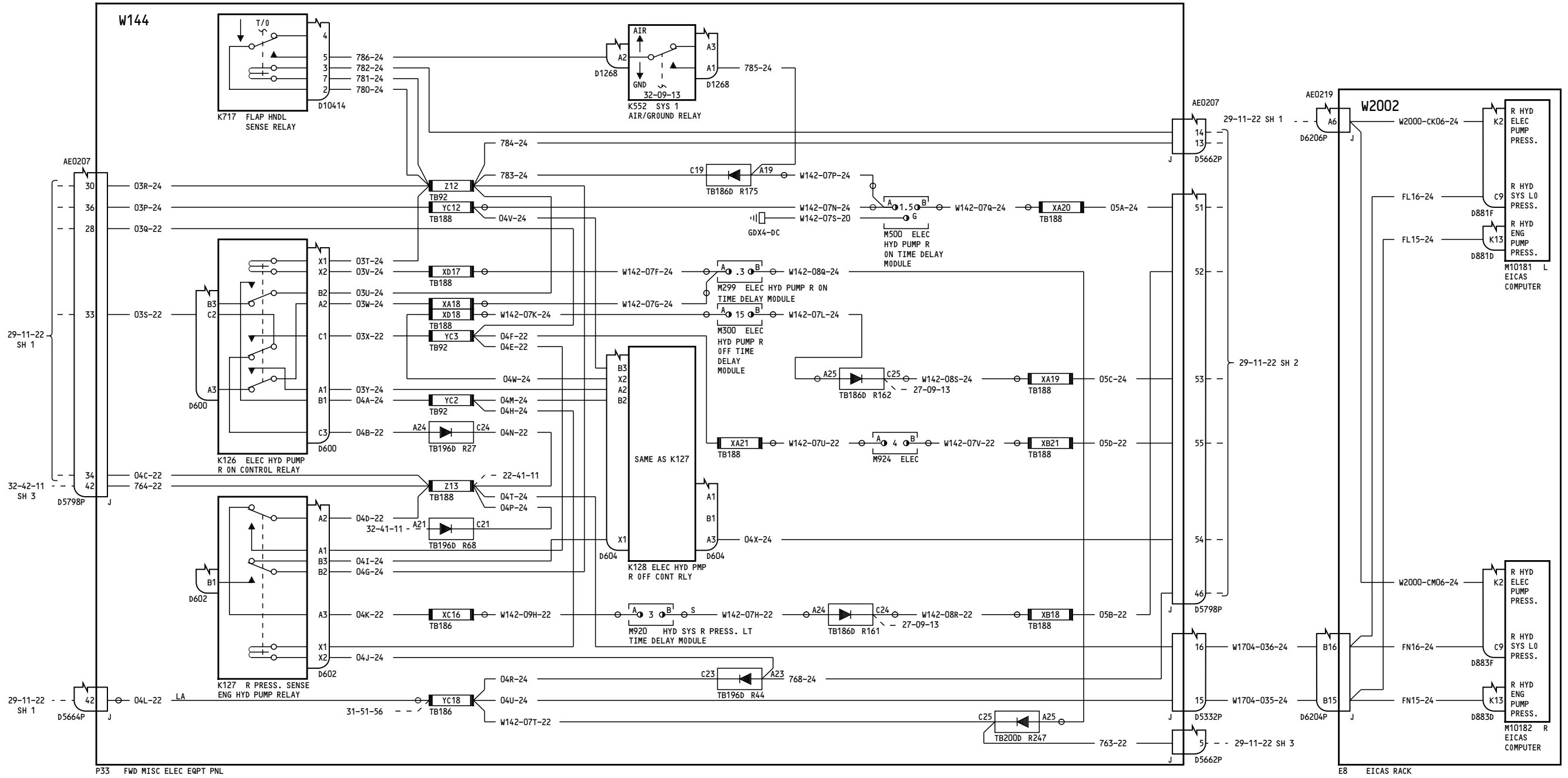

ALL

**ELECTRIC HYDRAULIC PUMP
RIGHT CONTROL &
INDICATION**

D280T132

29-11-22

Page 1
Sheet 2
Jan 21/2005

29-11-22

Page 1
Sheet 2
Jan 21/2005

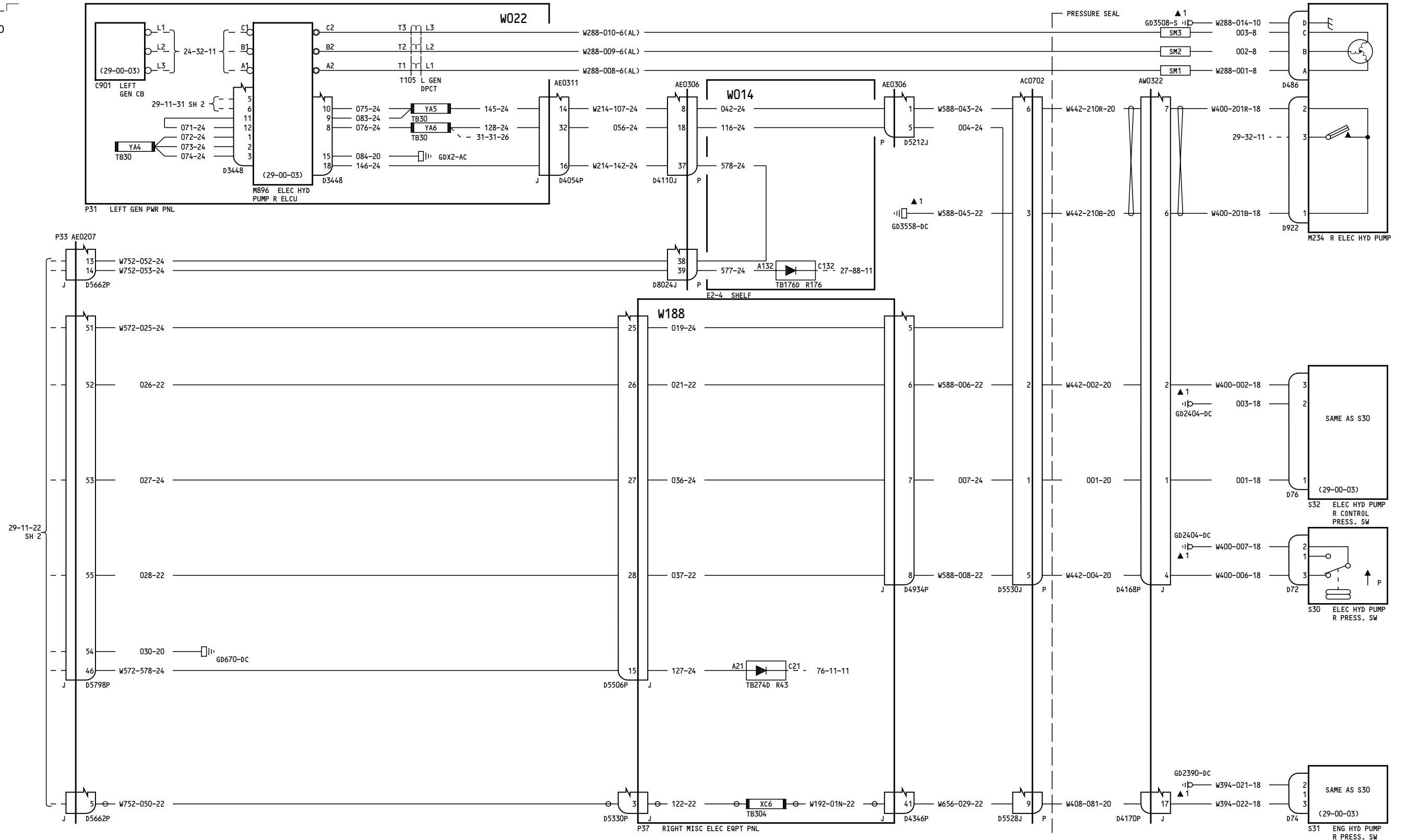

ALL

**ELECTRIC HYDRAULIC PUMP
RIGHT CONTROL &
INDICATION**

D280T132

29-11-22

Page 1
Sheet 3
Jan 21/2005

29-11-22

Page 1
Sheet 3
Jan 21/2005

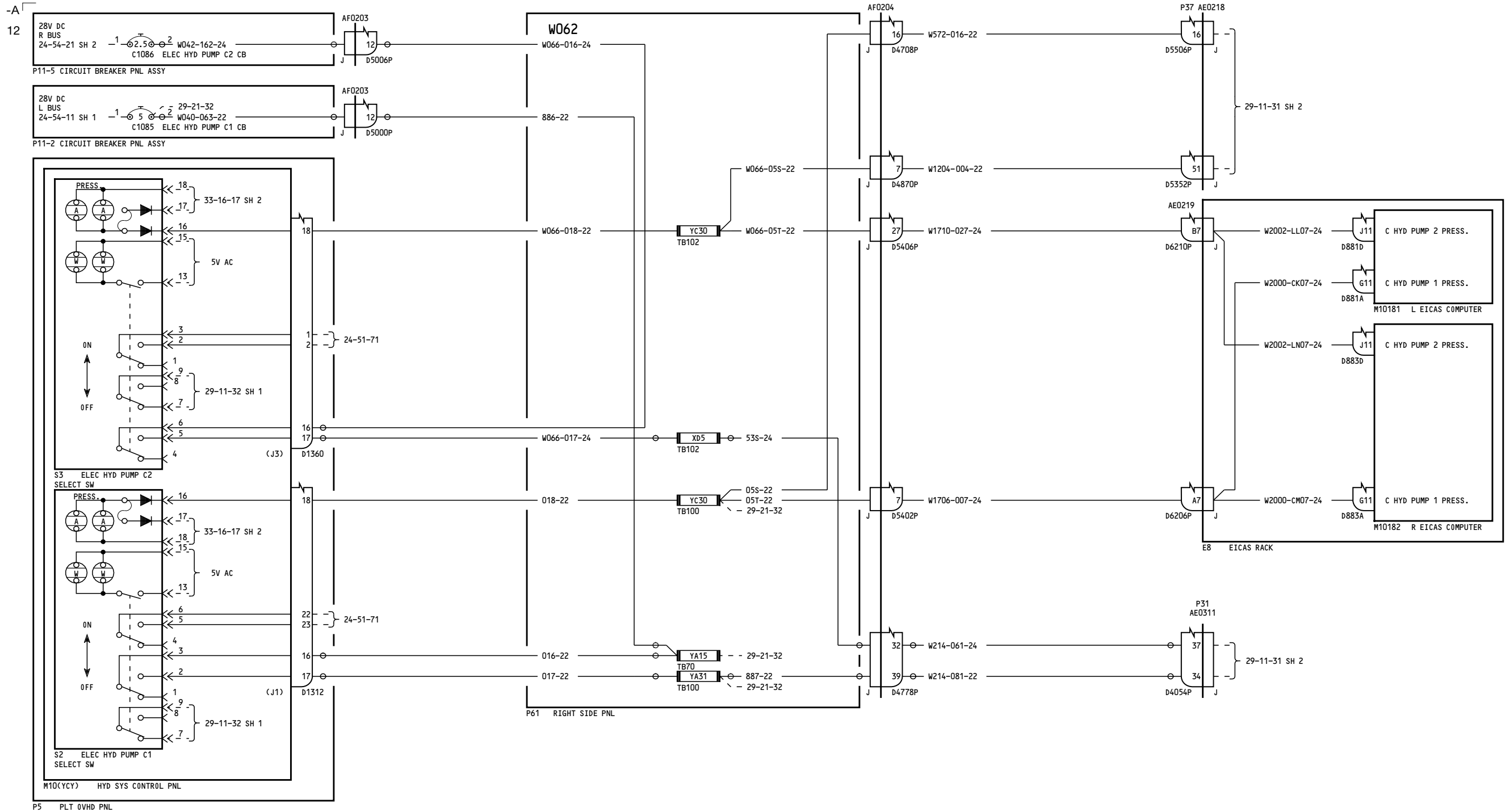

ALL

**ELECTRIC HYDRAULIC PUMPS
1 & 2 CONTROL &
INDICATION**

D280T132

29-11-31

Page 1
Sheet 1
Jan 21/2005

29-11-31

Page 1
Sheet 1
Jan 21/2005

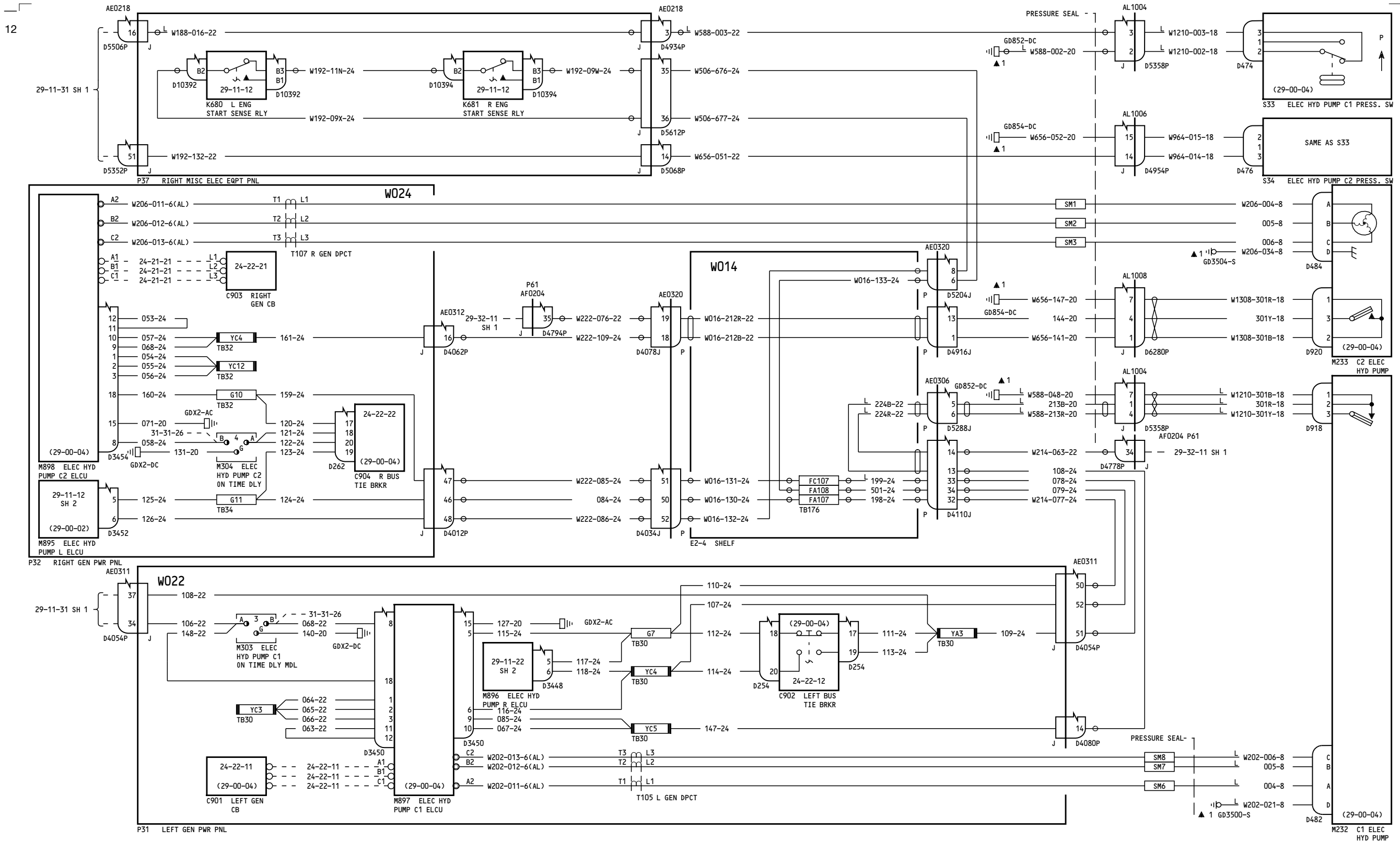

ALL

**ELECTRIC HYDRAULIC PUMPS
1 & 2 CONTROL &
INDICATION**

D280T132

29-11-31

Page 1
Sheet 2
Jan 21/2005

29-11-31

Page 1
Sheet 2
Jan 21/2005

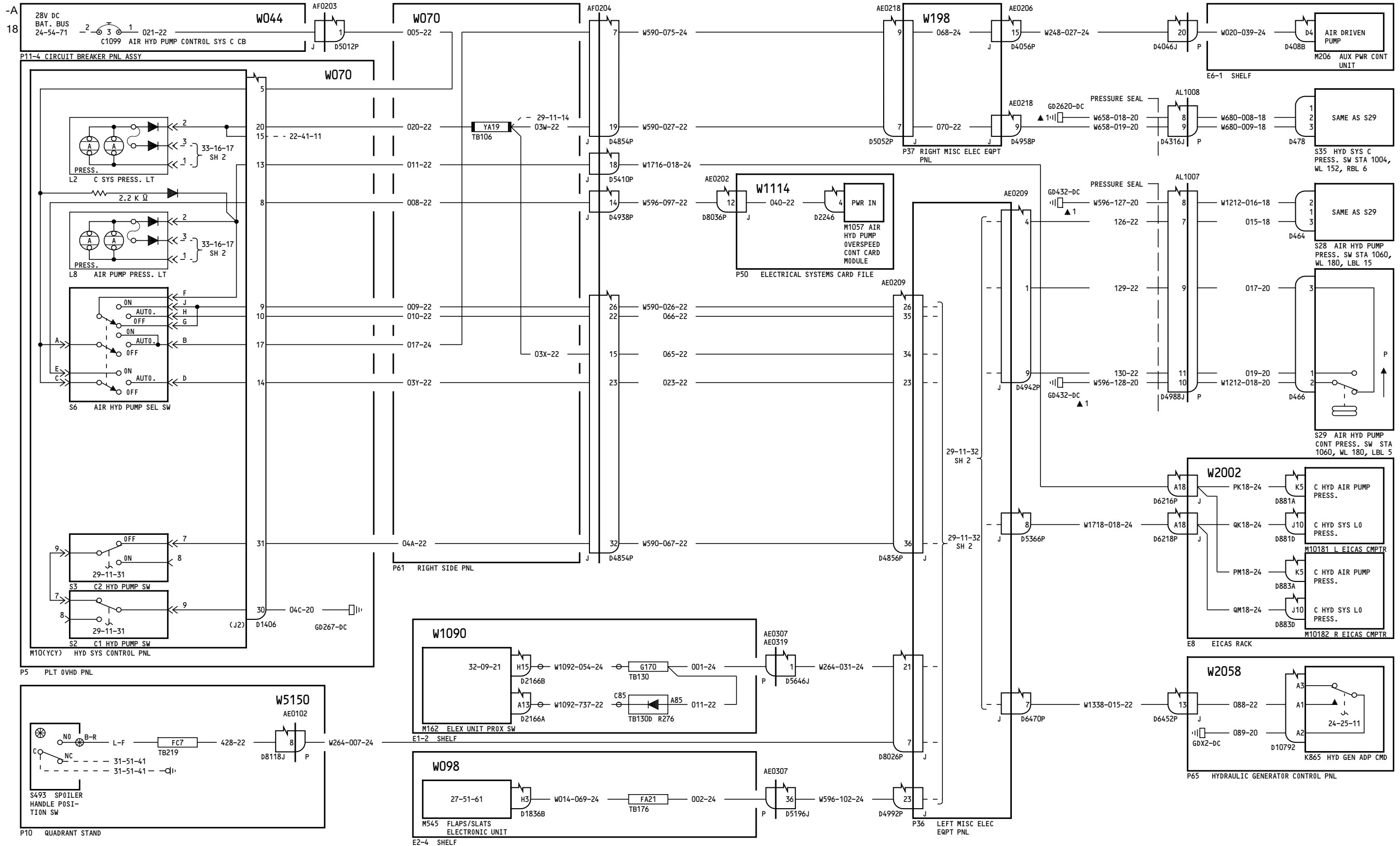

ALL

AIR HYDRAULIC PUMP CONTROL & INDICATION

D280T132

29-11-32

Page 1
Sheet 1
Jan 21/2005

29-11-32

Page 1
Sheet 1
Jan 21/2005

-A
18

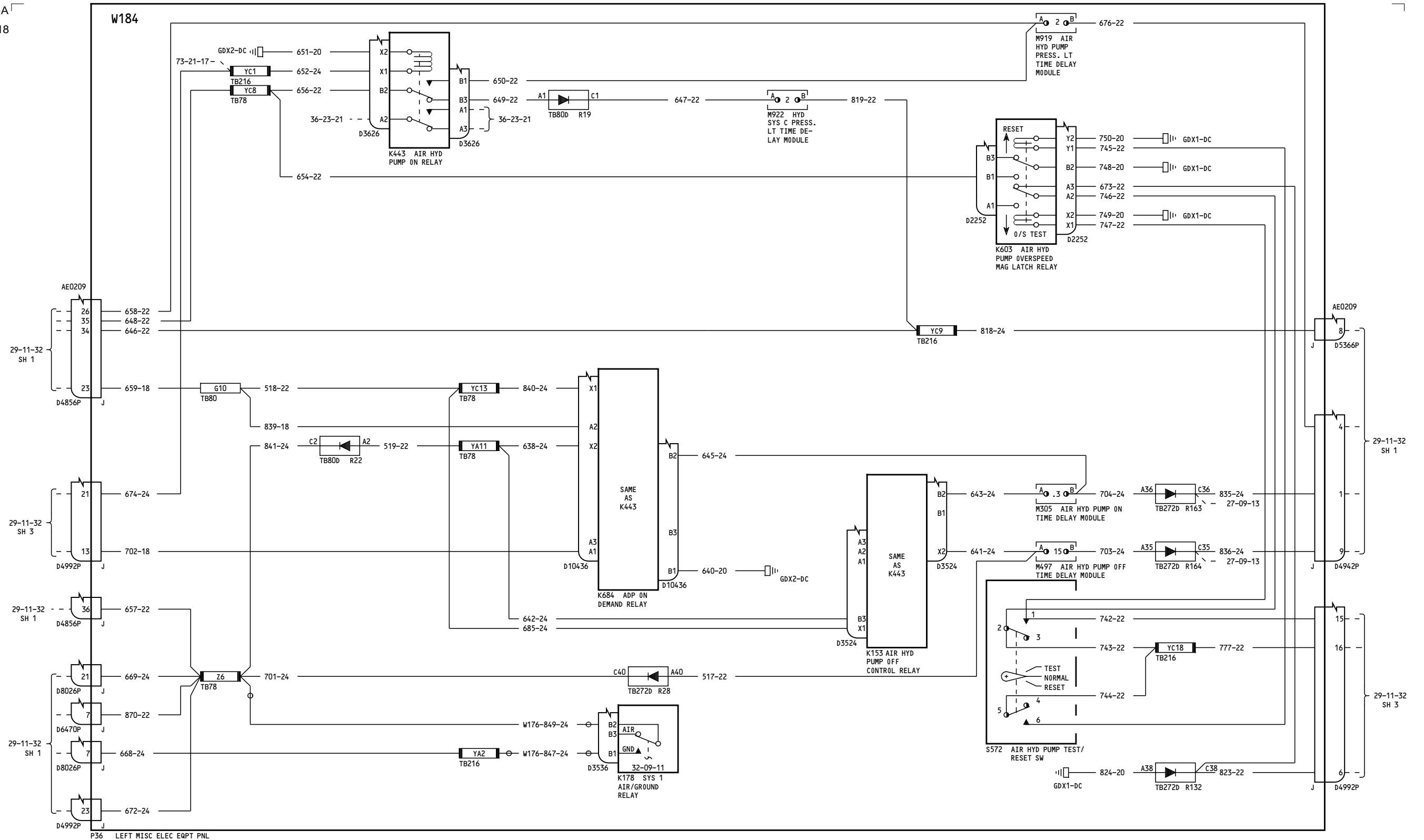

ALL

AIR HYDRAULIC PUMP CONTROL & INDICATION

29-11-32

Page 1
Sheet 2
Jan 21/2005

D280T132

29-11-32

Page 1
Sheet 2
Jan 21/2005

18

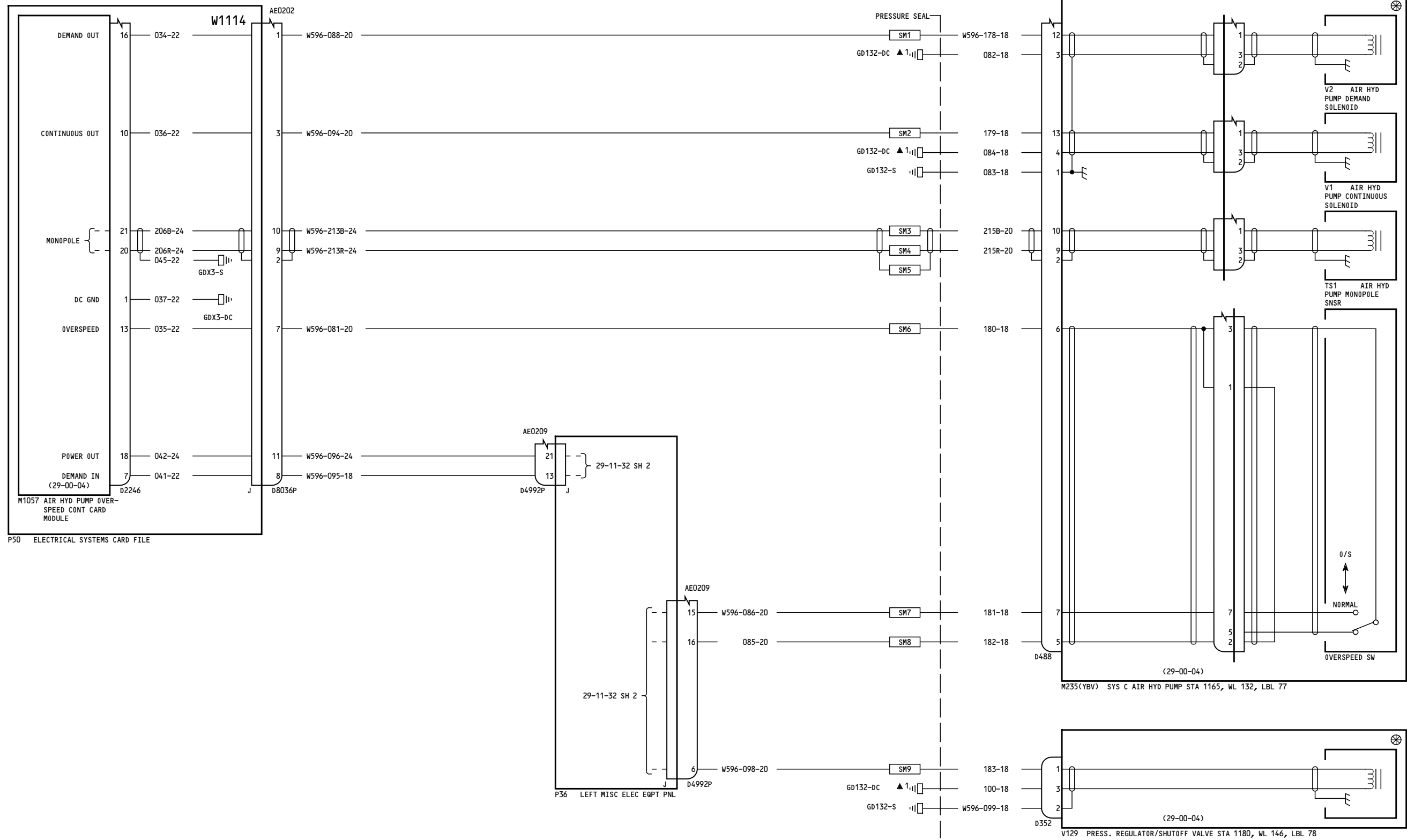

P50 ELECTRICAL SYSTEMS CARD FILE

P36 LEFT MISC ELEC EQPT PNL

M235(YBV) SYS C AIR HYD PUMP STA 1165, WL 132, LBL 77

V129 PRESS. REGULATOR/SHUTOFF VALVE STA 1180, WL 146, LBL 78

ALL

AIR HYDRAULIC PUMP CONTROL & INDICATION

29-11-32

Page 1
Sheet 3
Jan 21/2005

D280T132

29-11-32

Page 1
Sheet 3
Jan 21/2005

7

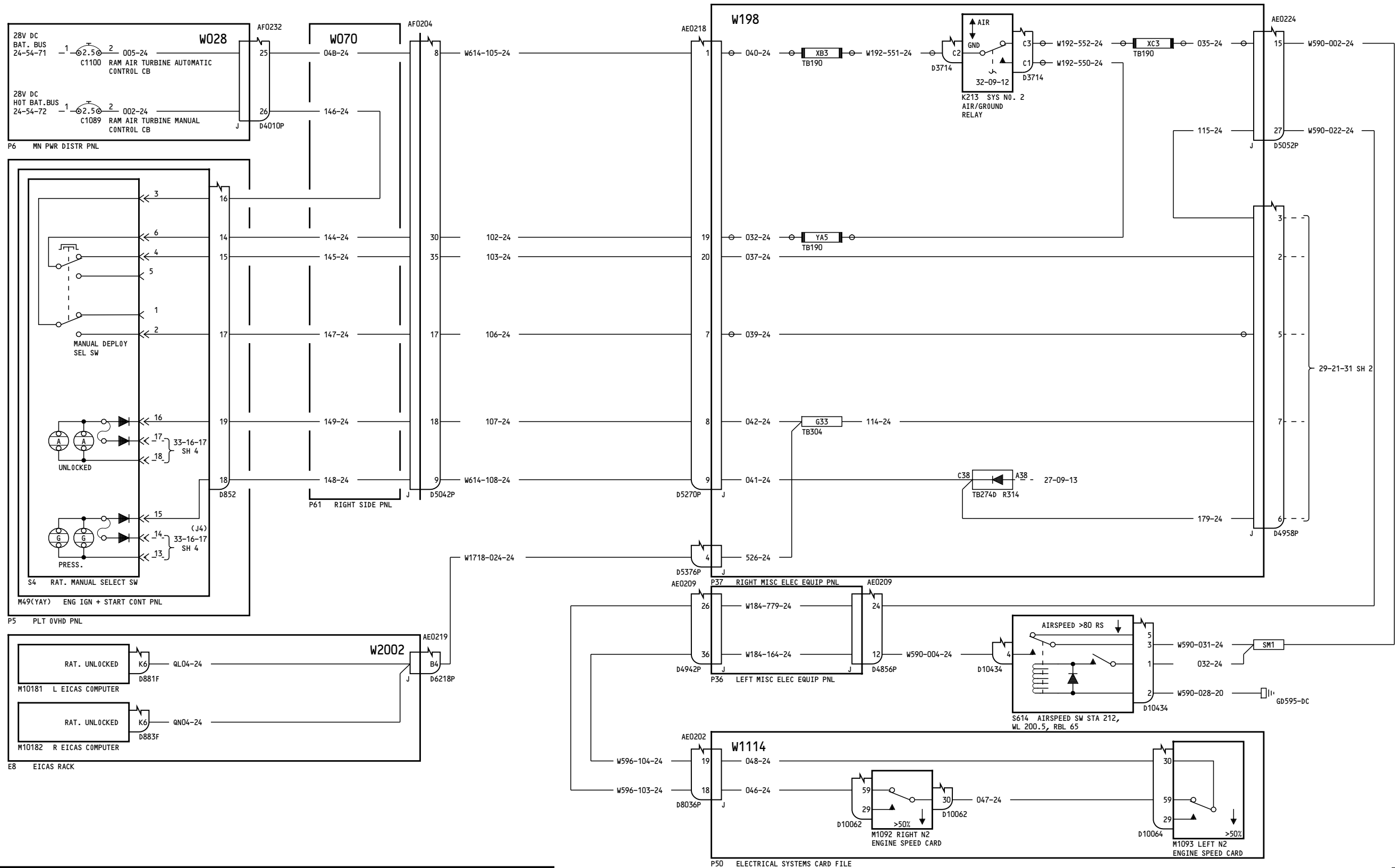

ALL

RAM AIR TURBINE CONTROL & INDICATION HYDRAULIC SYSTEM CENTER

D280T132

29-21-31

Page 1
Sheet 1
Jan 21/2005

29-21-31

Page 1
Sheet 1
Jan 21/2005

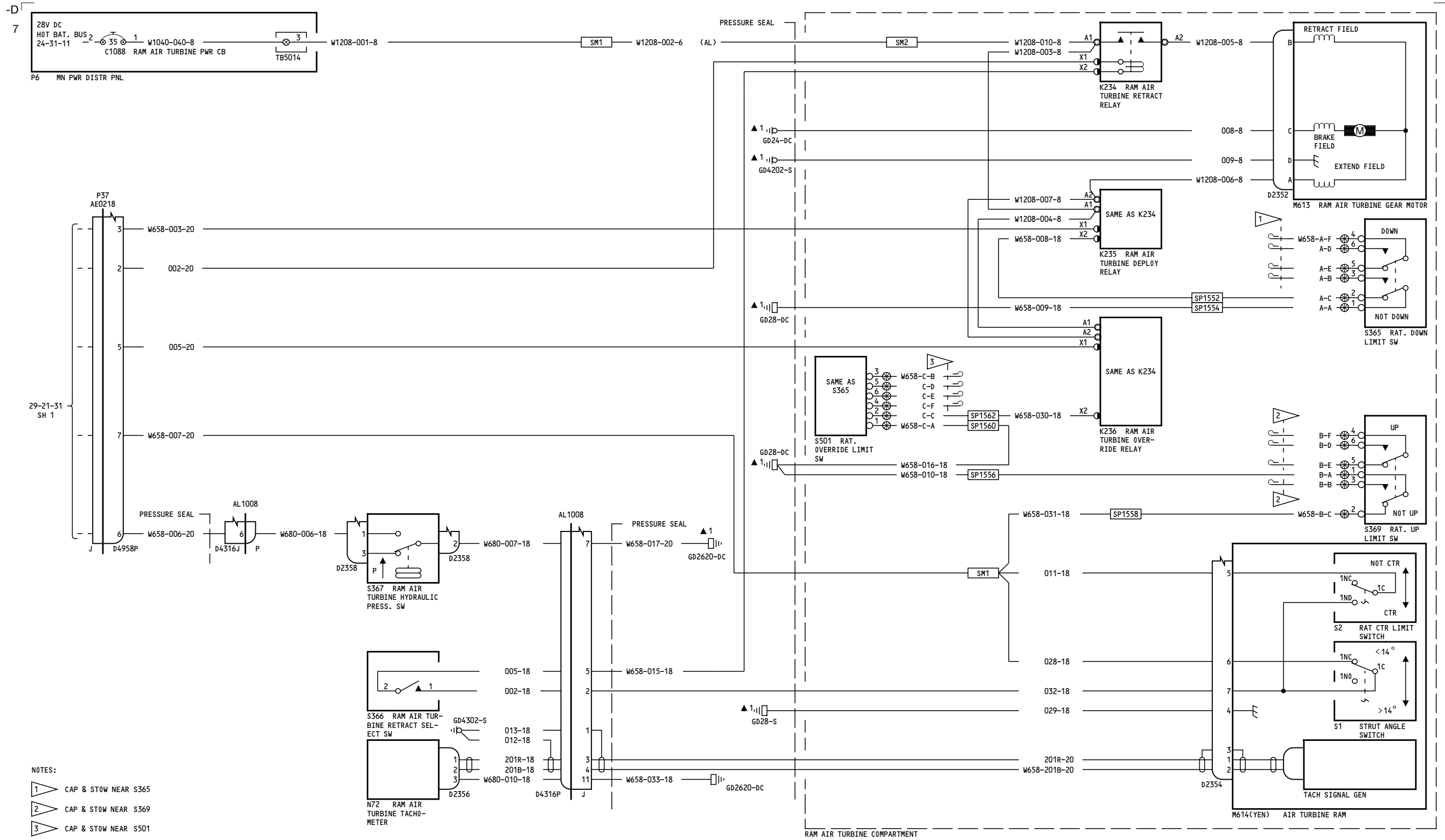

ALL

RAM AIR TURBINE CONTROL & INDICATION HYDRAULIC SYSTEM CENTER

D280T132

29-21-31

Page 1
Sheet 2
Jan 21/2005

29-21-31

Page 1
Sheet 2
Jan 21/2005

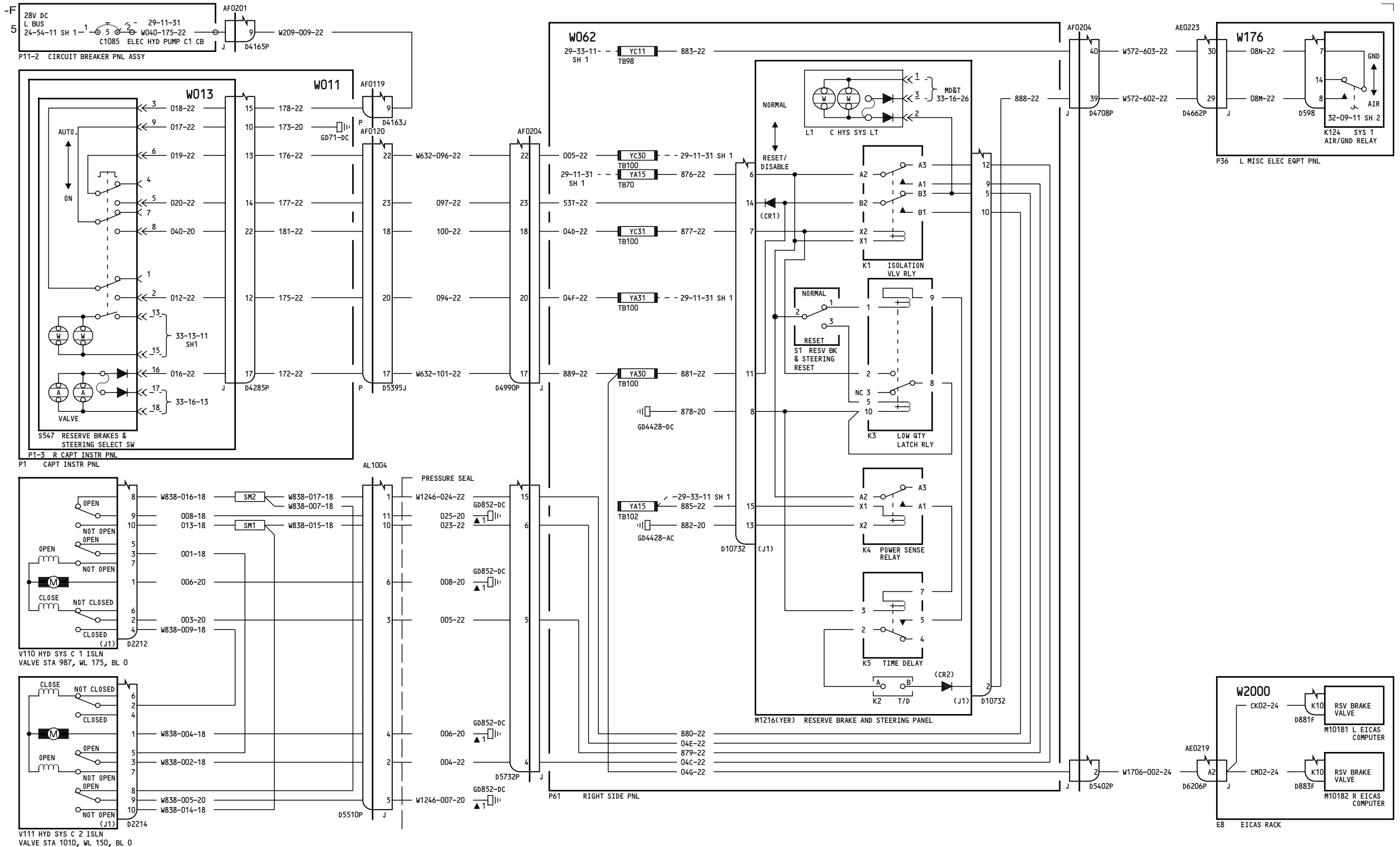

ALL

RESERVE HYDRAULIC SOURCE SELECT & INDICATION

D280T132

29-21-32

Page 1

Jan 21/2005

29-21-32

Page 1

Jan 21/2005

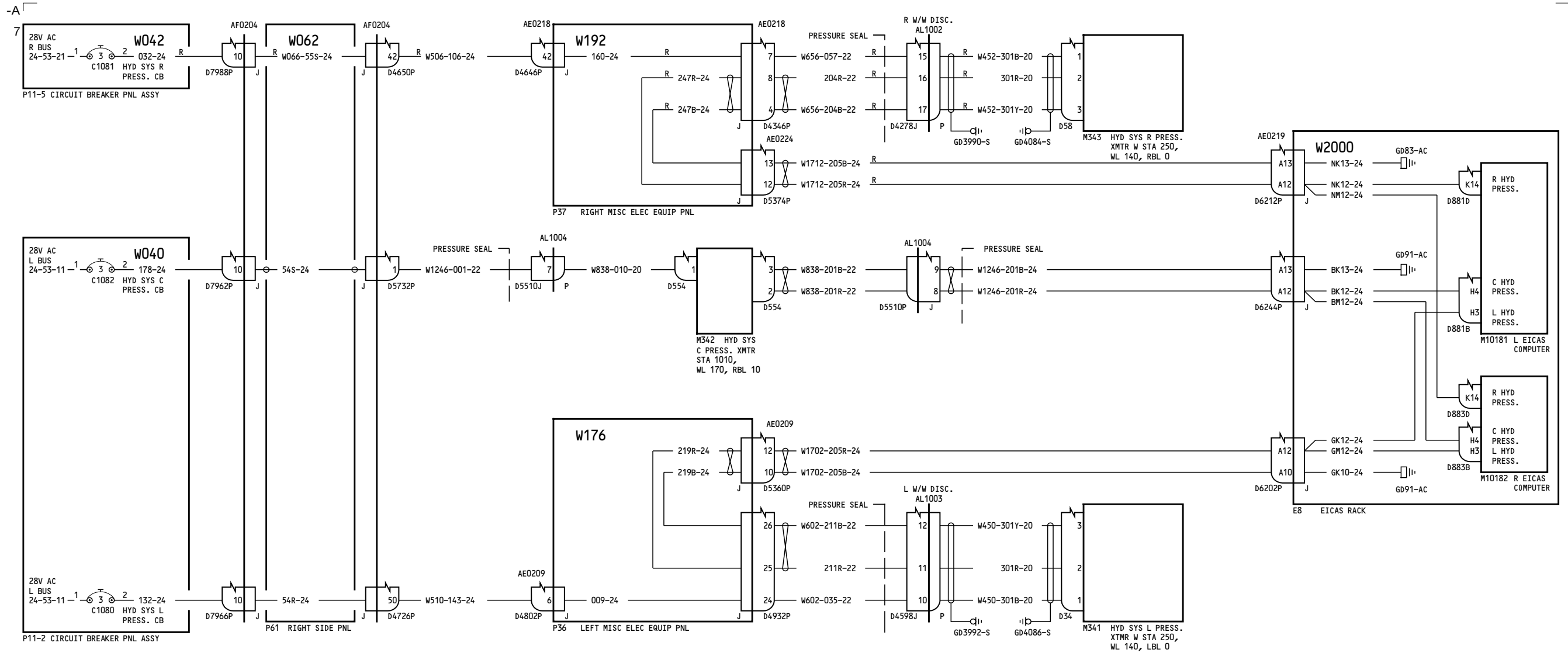

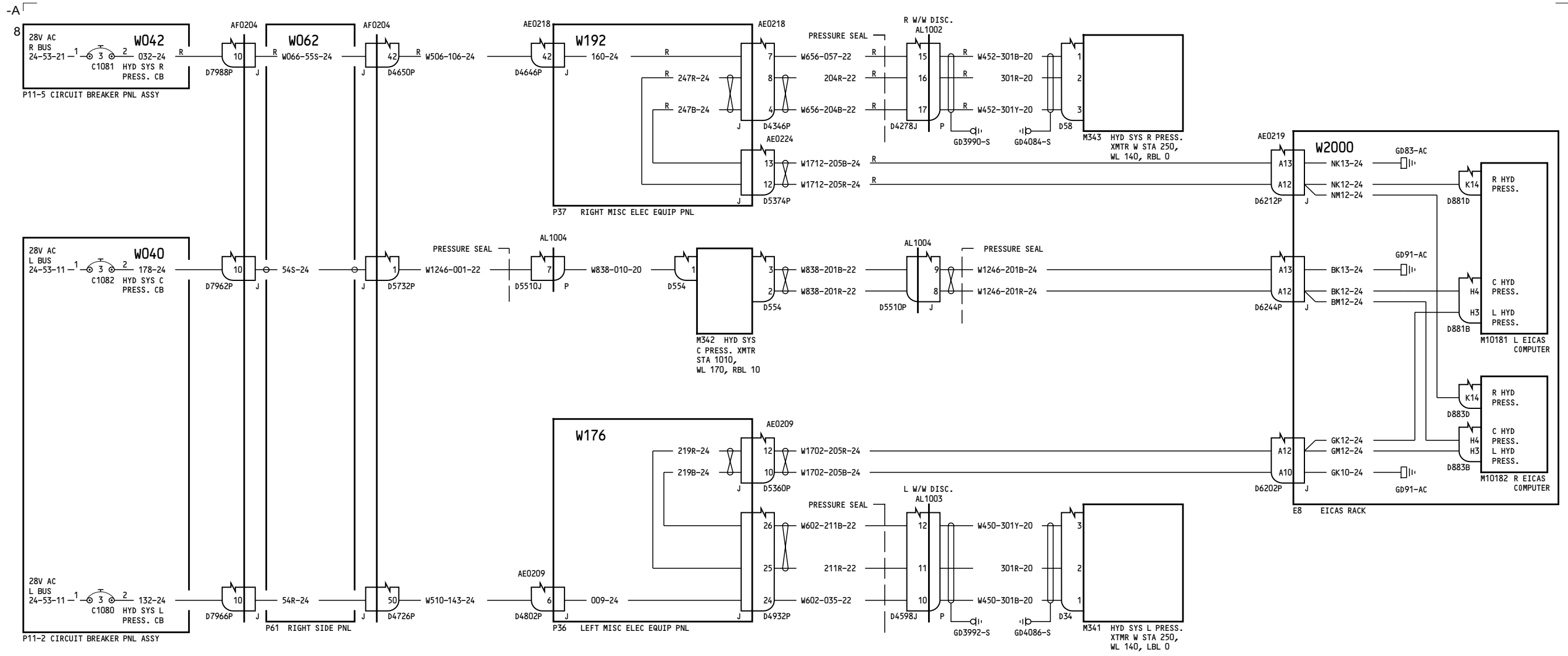

150-154, 162-164, 275-276

HYDRAULIC FLUID PRESSURE INDICATOR SYSTEM

29-31-11

Page 2

Jan 21/2005

D280T132

29-31-11

Page 2

Jan 21/2005

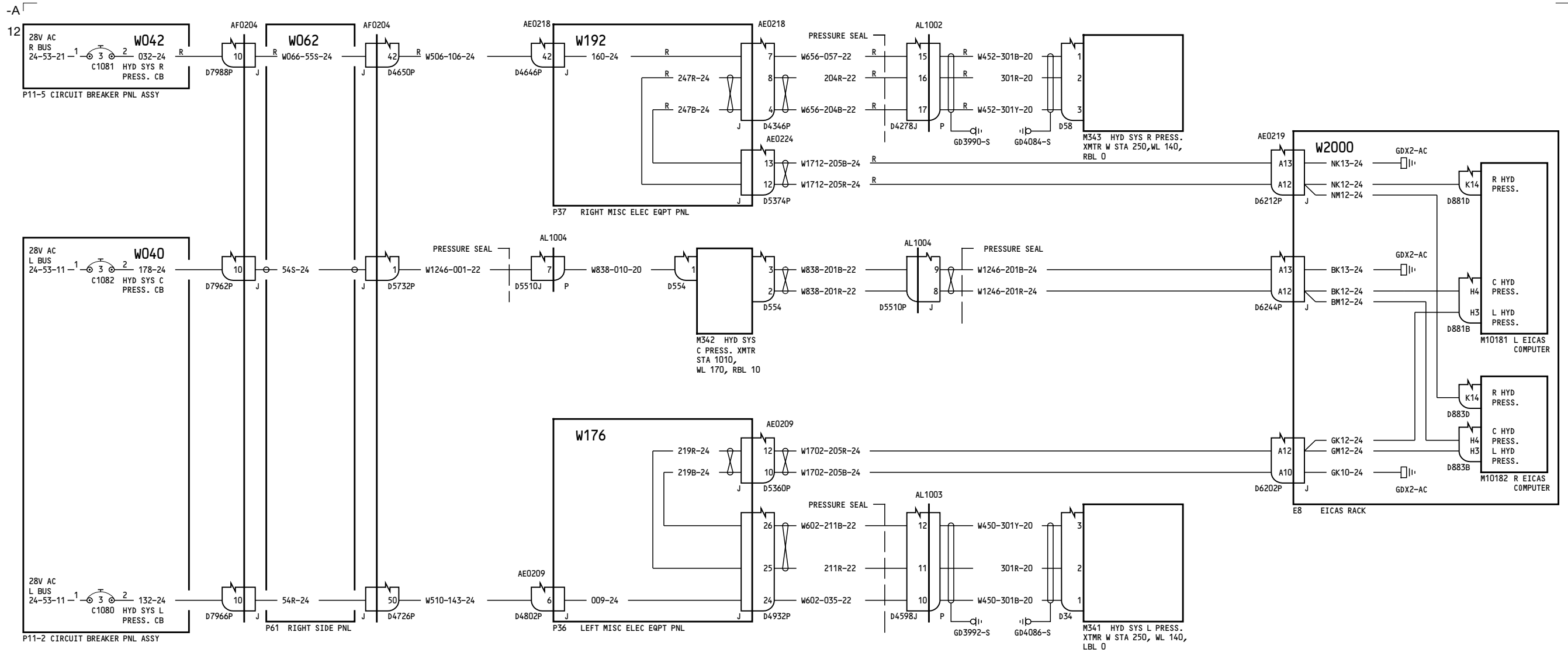

12

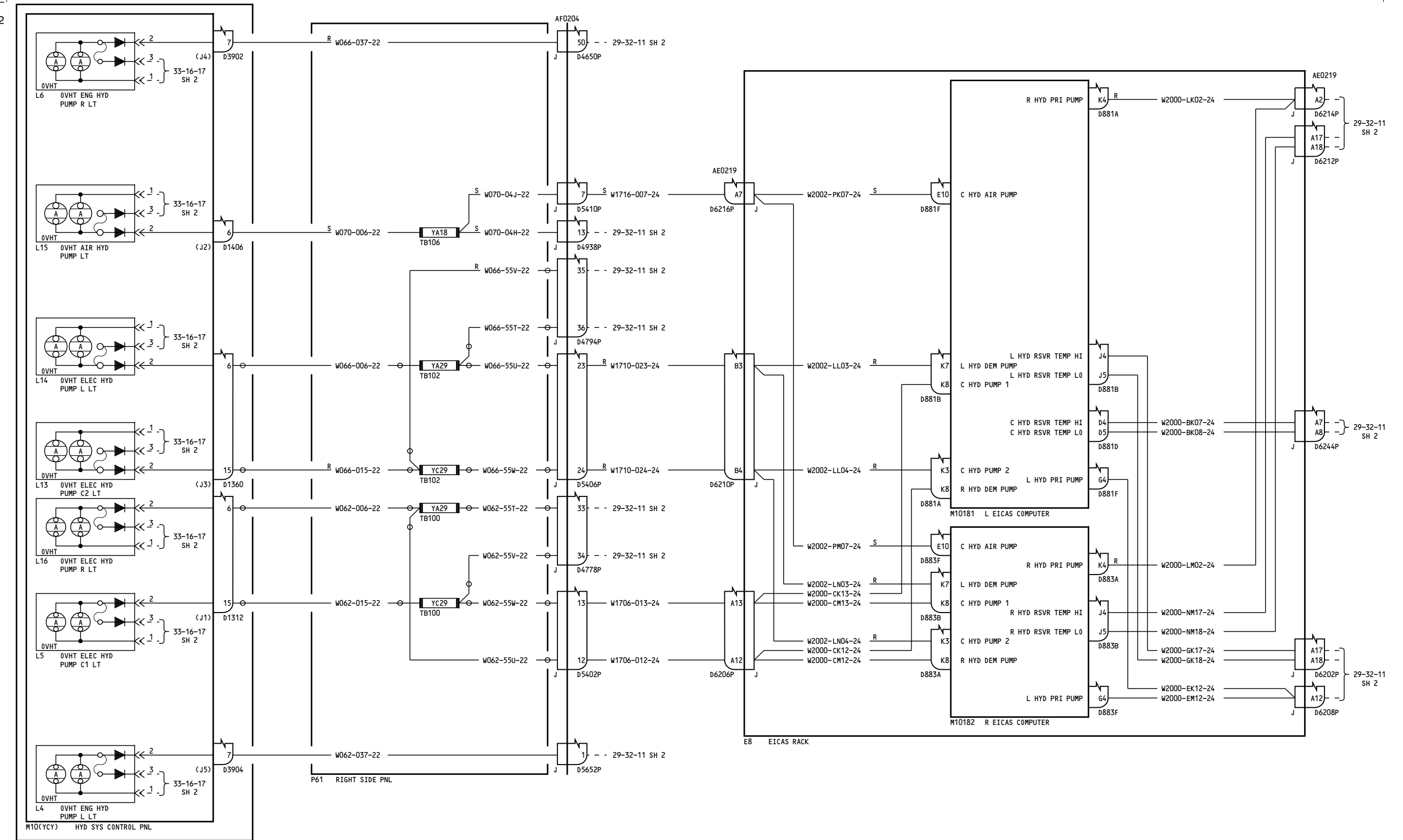

P5 PLT OVHD PNL
 050-099, 150-199, 275-278

**HYDRAULIC FLUID
 TEMPERATURE INDICATION
 SYSTEM**

D280T132

BOEING PROPRIETARY - Copyright © - Unpublished Work - See title page for details.



767-200/300 WIRING DIAGRAM MANUAL

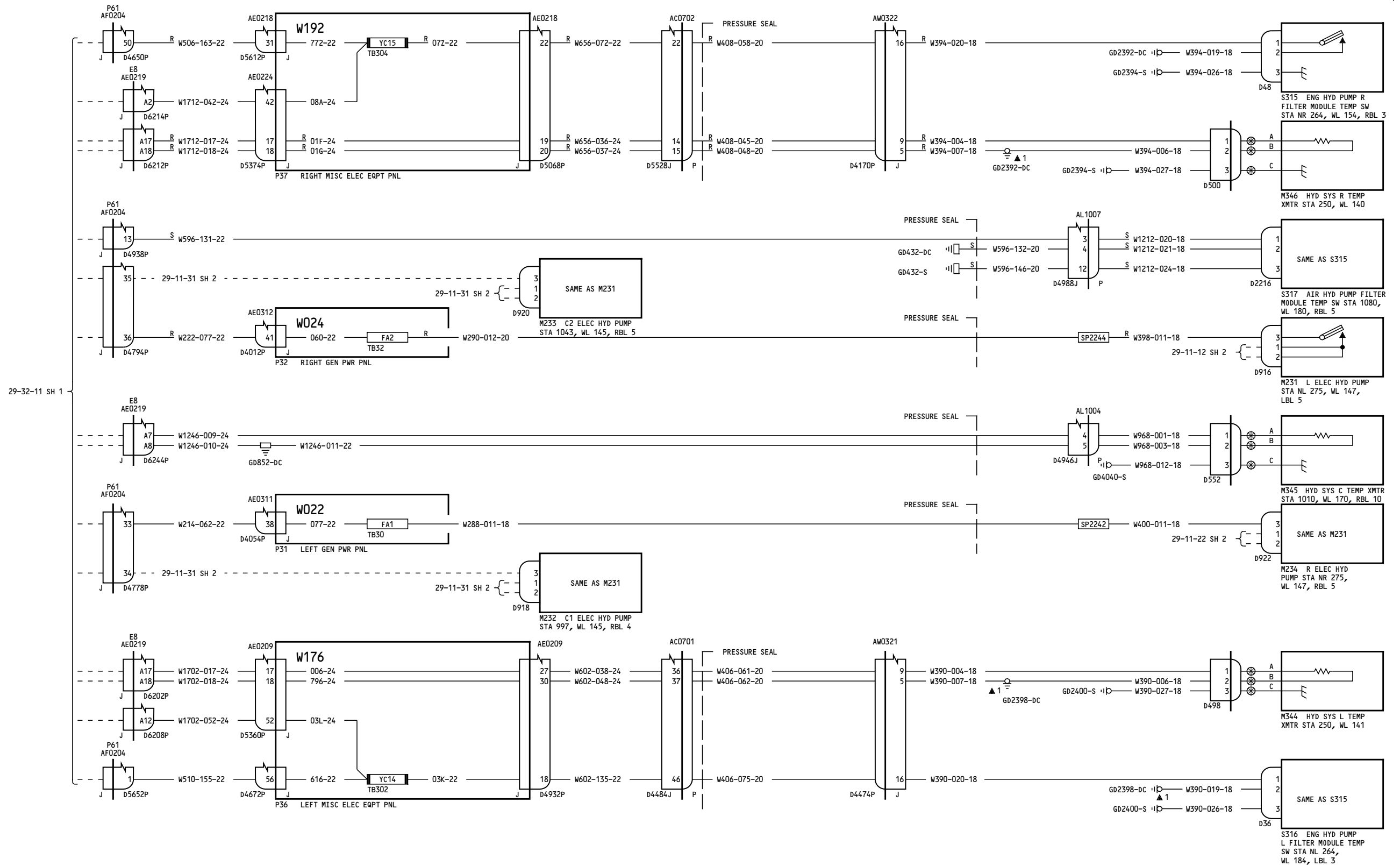

050-099, 150-199, 275-278

HYDRAULIC FLUID TEMPERATURE INDICATION SYSTEM

D280T132

29-32-11

Page 1
Sheet 2
Jan 21/2005

29-32-11

Page 1
Sheet 2
Jan 21/2005

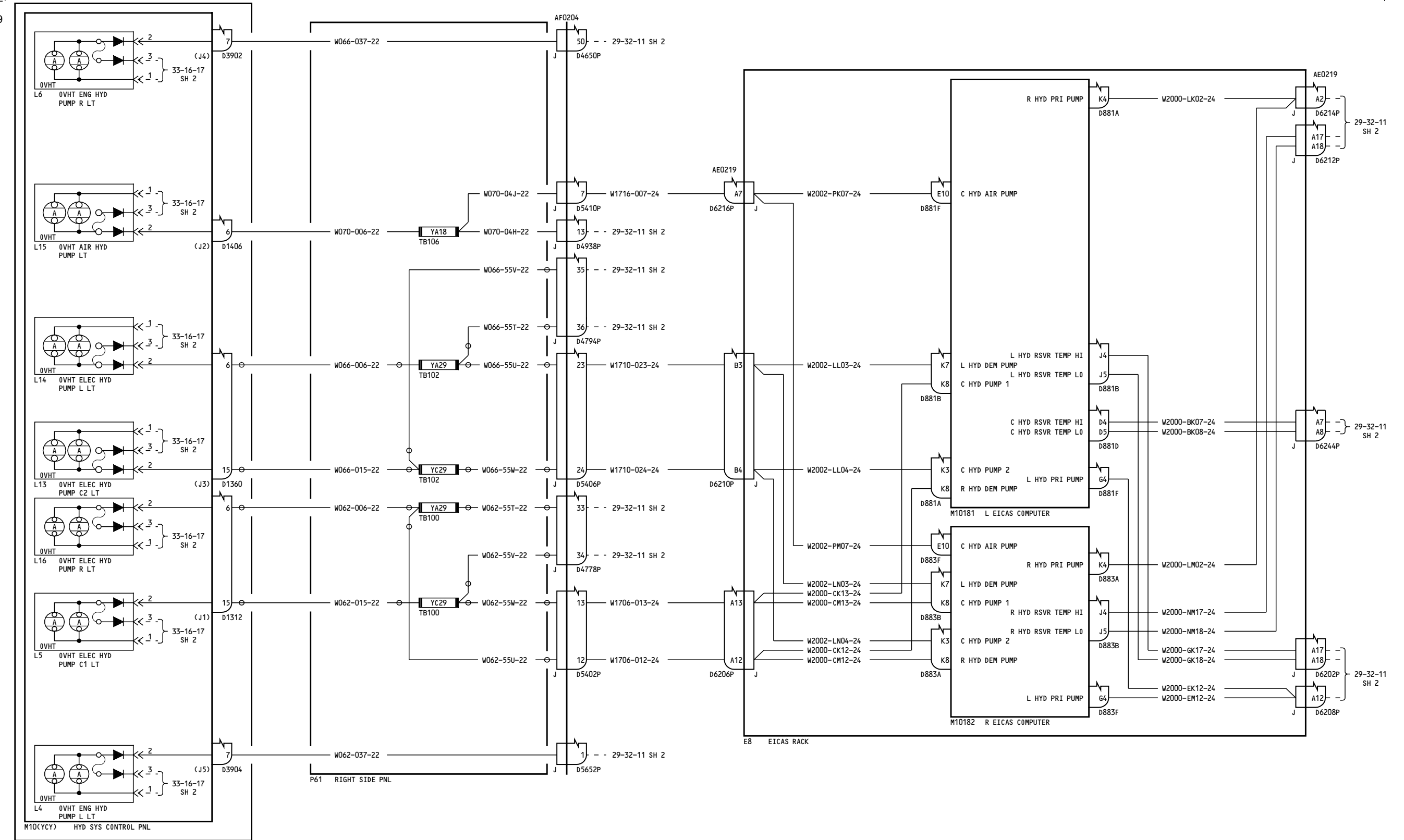

280-299
 P5 PLT OVHT PNL
 D280T132

HYDRAULIC FLUID TEMPERATURE INDICATION SYSTEM
29-32-11
 Page 2
 Sheet 1
 Jan 21/2005

29-32-11
 Page 2
 Sheet 1
 Jan 21/2005

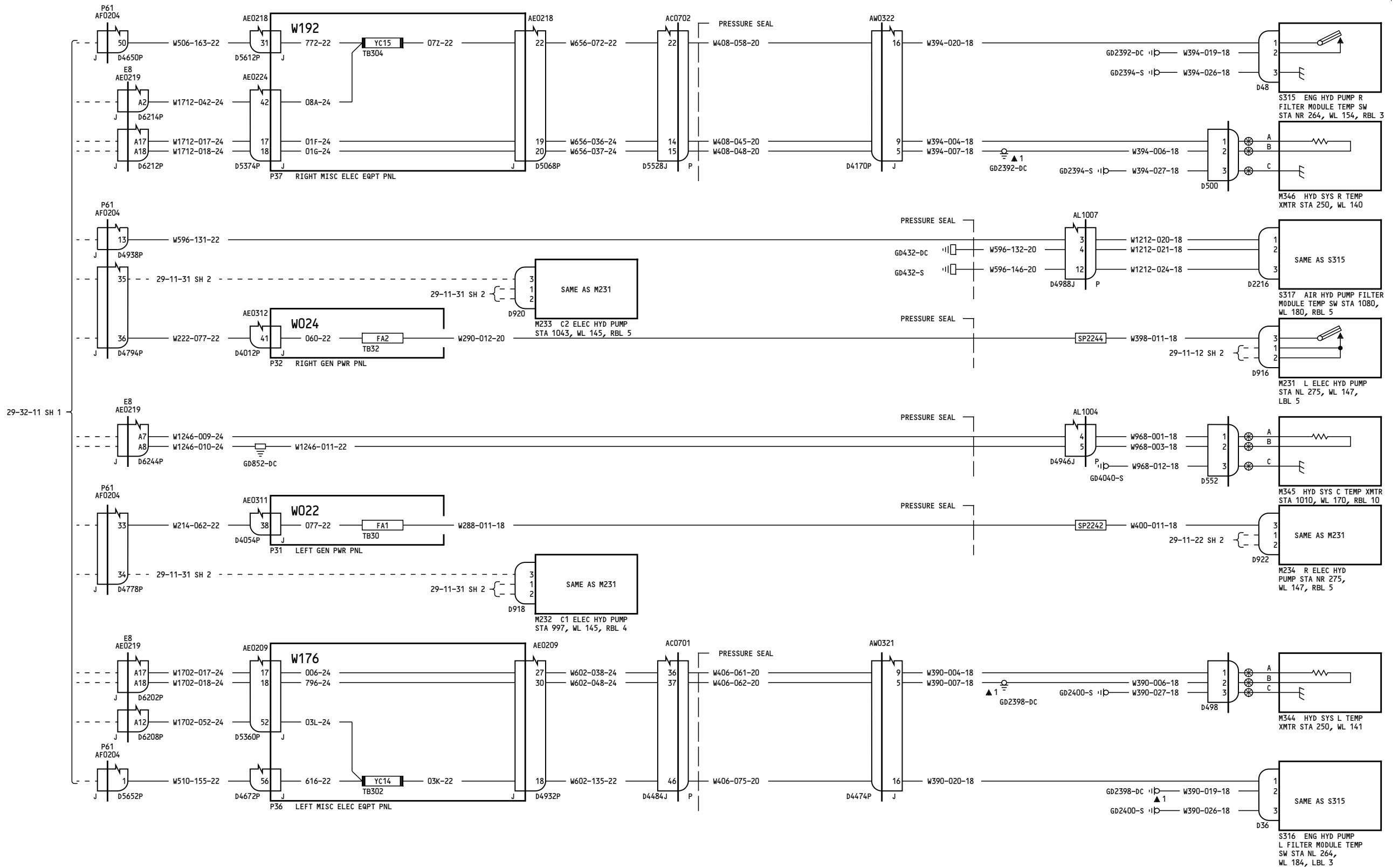

280-299

HYDRAULIC FLUID TEMPERATURE INDICATION SYSTEM

D280T132

29-32-11

Page 2
Sheet 2
Jan 21/2005

29-32-11

Page 2
Sheet 2
Jan 21/2005

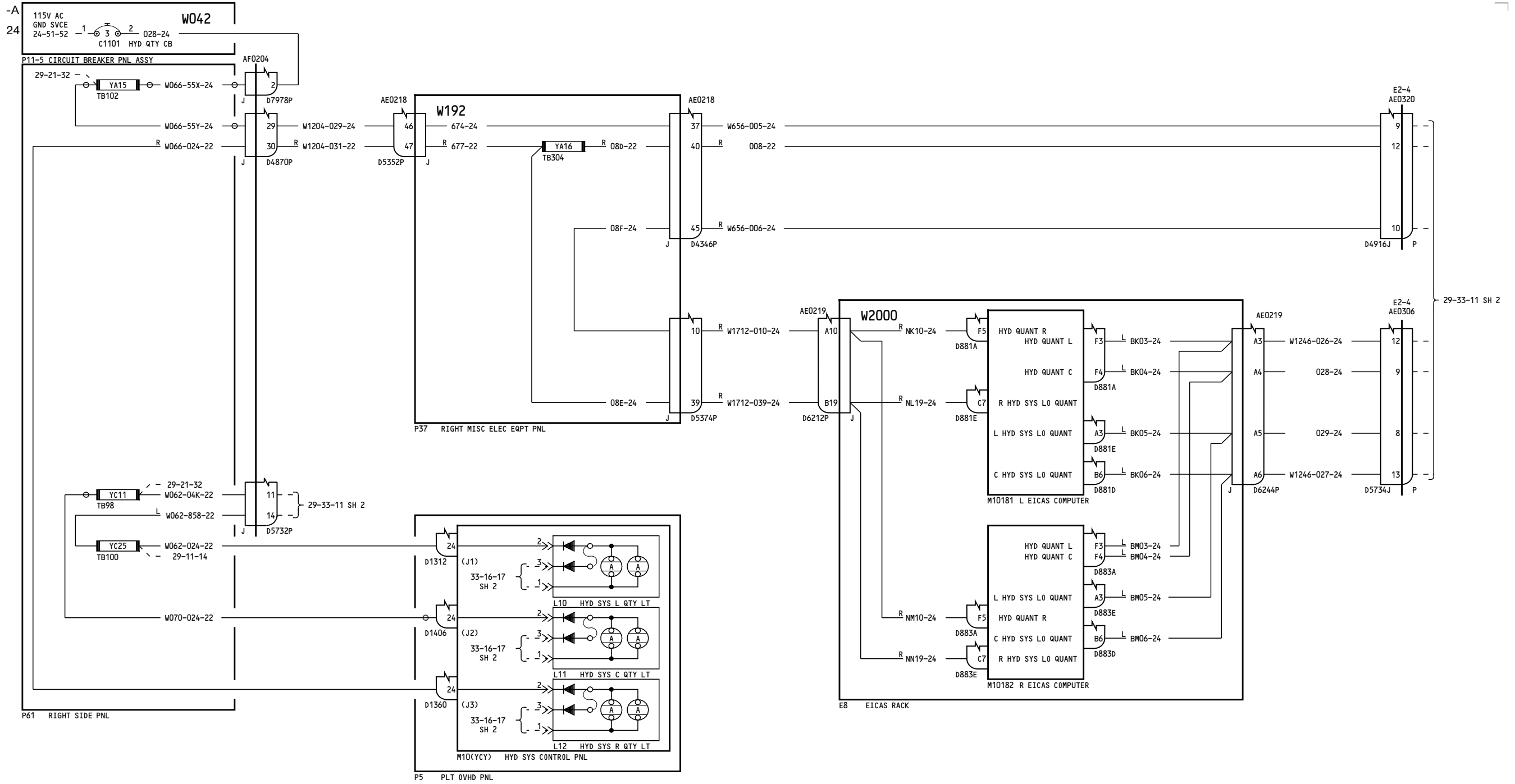

050-051, 275-280

HYDRAULIC FLUID QUANTITY INDICATION SYSTEM

29-33-11

Page 1.1
Sheet 1
Jan 21/2005

D280T132

29-33-11

Page 1.1
Sheet 1
Jan 21/2005

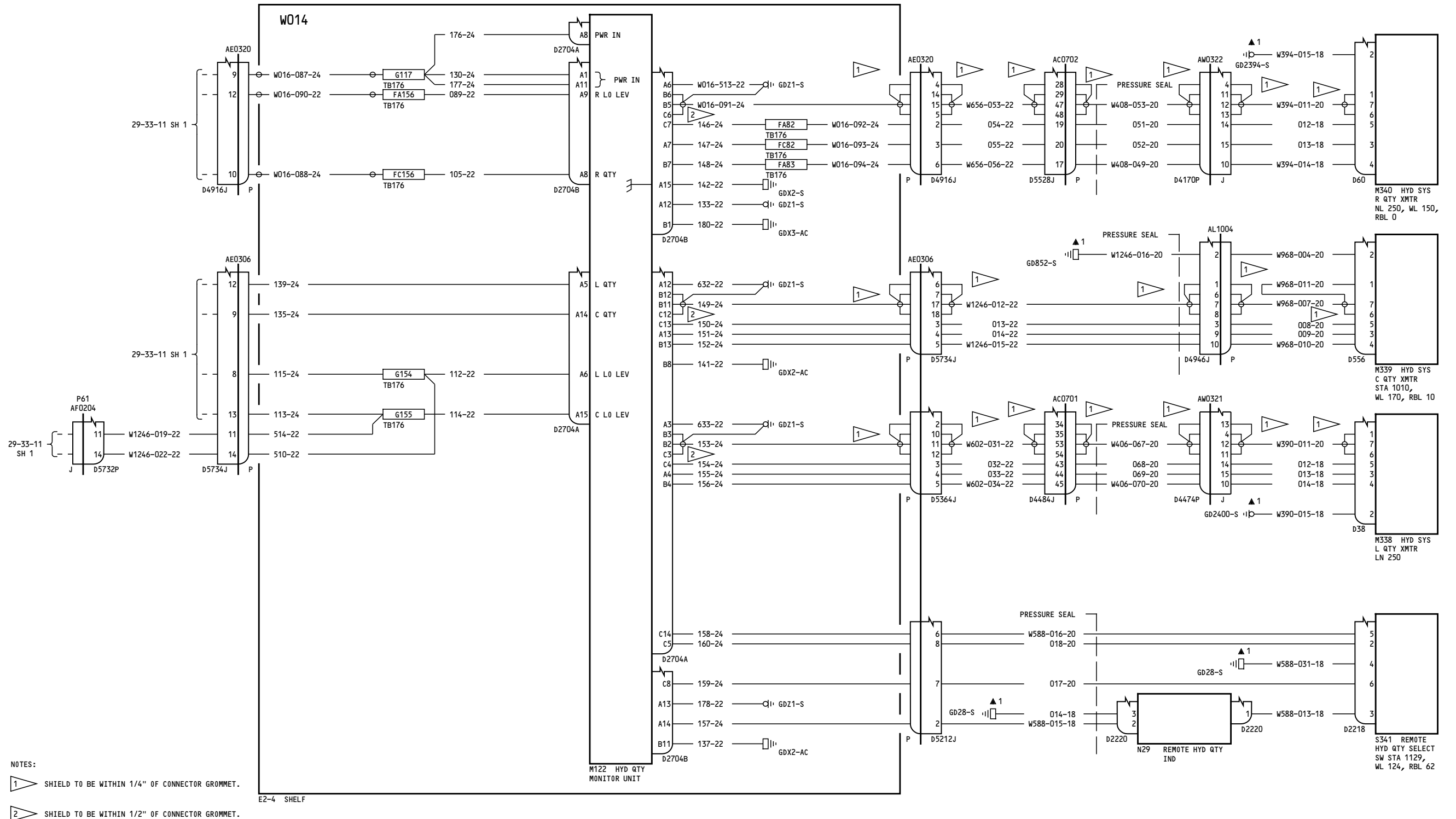

050-051, 275-280

HYDRAULIC FLUID QUANTITY INDICATION SYSTEM

29-33-11

Incorporates
29-0067

Page 1.1
Sheet 2
Jan 21/2005

D280T132

29-33-11

Page 1.1
Sheet 2
Jan 21/2005

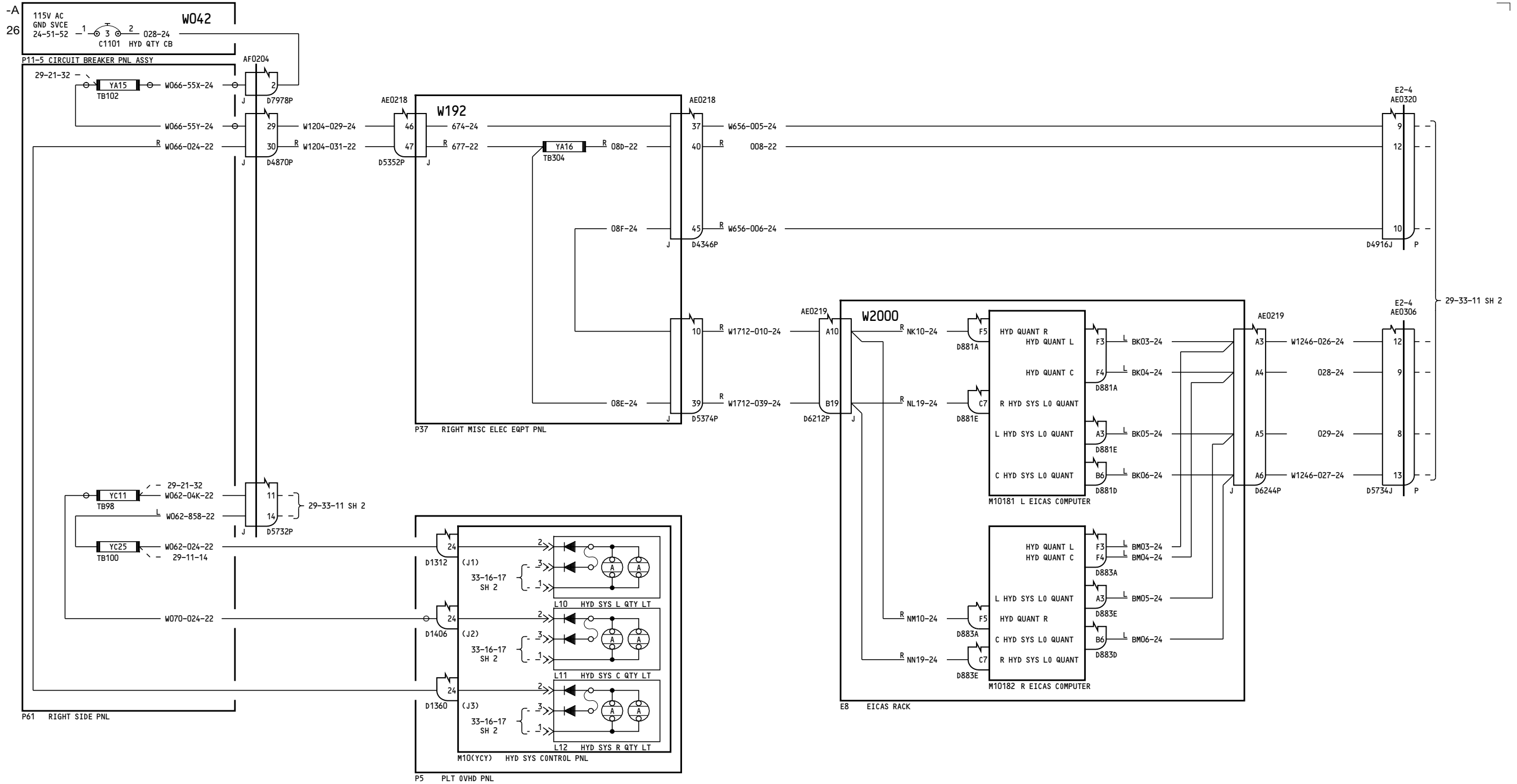

150-167

HYDRAULIC FLUID QUANTITY INDICATION SYSTEM

29-33-11

Page 2.1
Sheet 1
Jan 21/2005

D280T132

29-33-11

Page 2.1
Sheet 1
Jan 21/2005

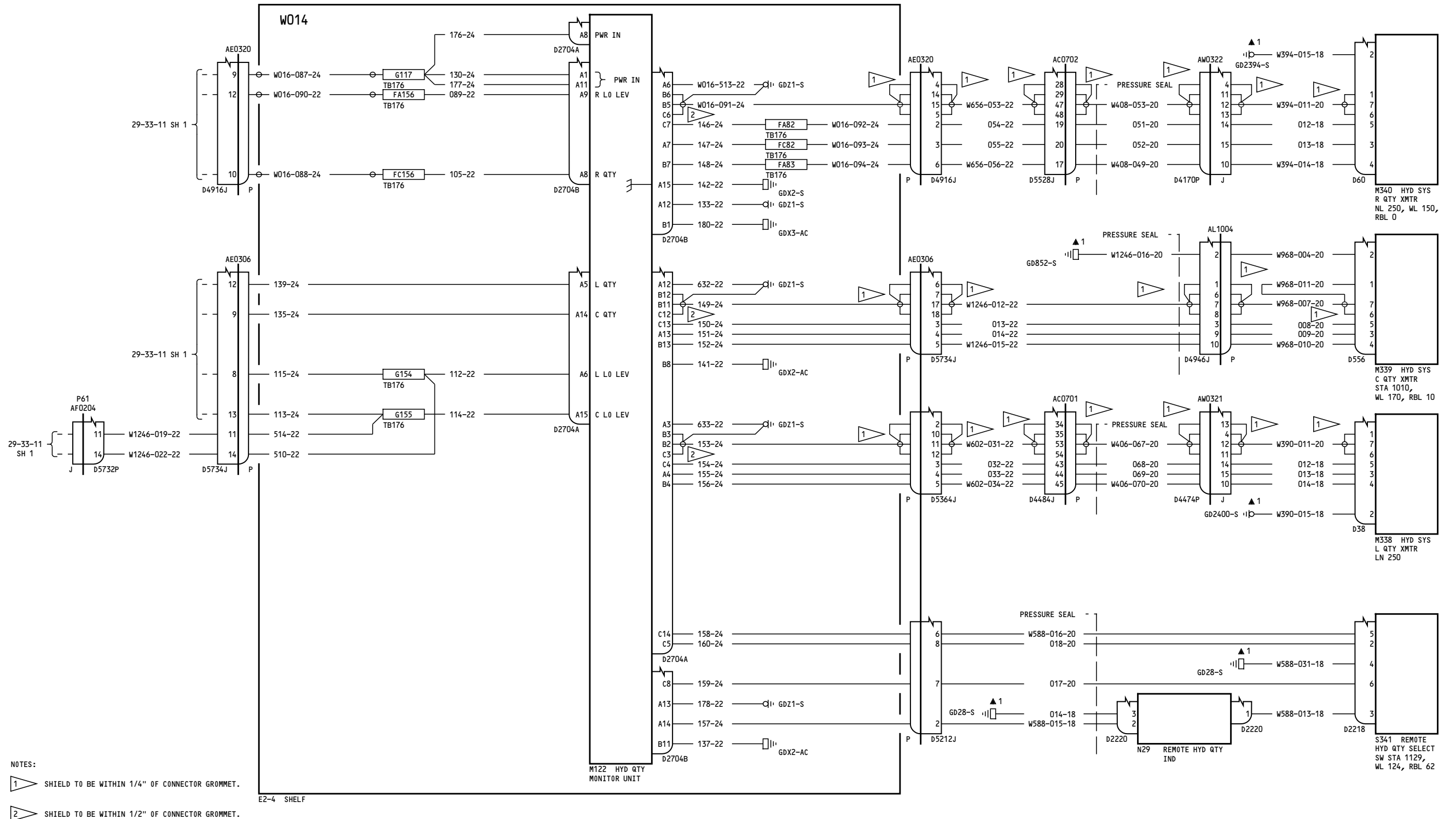

150-167

HYDRAULIC FLUID QUANTITY INDICATION SYSTEM

D280T132

29-33-11

Page 2.1
Sheet 2
Jan 21/2005

Incorporates
29-0067

29-33-11

Page 2.1
Sheet 2
Jan 21/2005