

CHAPTER

30

**ICE AND RAIN
PROTECTION**



767-200/300

WIRING DIAGRAM MANUAL

CHAPTER 30
ICE AND RAIN PROTECTION

CH-SC-SU	Schem	Page	Sheet	Date	CH-SC-SU	Schem	Page	Sheet	Date
30-EFFECTIVE PAGES		1 thru 2		Aug 05/2009	30-34-21 (cont.)		2		Jan 21/2005
30-CONTENTS					30-41-11		1	1	Jan 21/2005
R		1		Aug 05/2009				2	Jan 21/2005
		2		Jun 28/2006		2.1	1	2	Jan 21/2005
		3		Jun 28/2006				1	Jan 21/2005
		4		Jun 28/2006				2	Jan 21/2005
30-ALPHABETICAL INDEX						3	1	1	Jan 21/2005
		1		Jan 21/2005				2	Jan 21/2005
		2		BLANK	30-41-12		1	1	Jan 21/2005
30-11-11								2	Jan 21/2005
		1	1	Jan 21/2005		2.1	1	2	Jan 21/2005
			2	Jan 21/2005				2	Jan 21/2005
		2	1	Jan 21/2005		3	1	1	Jan 21/2005
			2	Jan 21/2005				2	Jan 21/2005
		2.1	1	Jan 21/2005	30-42-11		1		Jan 21/2005
			2	Jan 21/2005					
		3.1	1	Jan 21/2005	30-43-11		1.1		Jan 21/2005
			2	Jan 21/2005			2		Jan 21/2005
		4	1	Jan 21/2005			3		Jan 21/2005
			2	Jan 21/2005	30-46-11		1		Jan 21/2005
30-21-11					30-71-11		1		Jan 21/2005
		1	1	Jan 21/2005			2		Jan 21/2005
			2	Jan 21/2005			3		Jan 21/2005
			3	Jan 21/2005	30-71-21		1	1	Jan 21/2005
		2	1	Jan 21/2005				2	Jan 21/2005
			2	Jan 21/2005				1	Jan 21/2005
		2.1	1	Jan 21/2005				2	Jan 21/2005
			2	Jan 21/2005				2	Jan 21/2005
			3	Jan 21/2005				3	Jan 21/2005
		3	1	Jan 21/2005				1	Jan 21/2005
			2	Jan 21/2005				2	Jan 21/2005
30-31-11								2	Jan 21/2005
		1.1		Mar 09/2006				3	Jan 21/2005
30-31-13								1	Jan 21/2005
		1.1		Mar 09/2006				2	Jan 21/2005
30-31-21								4	Jan 21/2005
		1		Aug 05/2009				5	Jan 21/2005
R 30-31-23								6	Jan 21/2005
		1		Jan 21/2005				7	Jan 21/2005
		2		Jan 21/2005	30-71-22		1		Jan 21/2005
30-32-11								2	Jan 21/2005
		1		Jan 21/2005				3	Jan 21/2005
30-32-21								4	Jan 21/2005
		1		Jan 21/2005				5	Jan 21/2005
30-33-11					30-71-23		1		Jan 21/2005
		1		Jan 21/2005				1.1	Jan 21/2005
30-34-11								2	Jan 21/2005
		1.1		Mar 09/2006				2.1	Jan 21/2005
		2.1		Mar 09/2006				3	Jan 21/2005
30-34-21								3.1	Jan 21/2005
		1		Jan 21/2005					

A = Added, R = Revised, D = Deleted, O = Overflow

30-EFFECTIVE PAGES

Page 1
Aug 05/2009

D280T132



767-200/300

WIRING DIAGRAM MANUAL

CHAPTER 30 ICE AND RAIN PROTECTION

CH-SC-SU	Schem	Page	Sheet	Date	CH-SC-SU	Schem	Page	Sheet	Date
30-71-23 (cont.)		4		Jan 21/2005					
		4.1		Jan 21/2005					
		5		Jan 21/2005					
		5.1		Jan 21/2005					
		6		Jan 21/2005					
		6.1		Jan 21/2005					
		7		Jan 21/2005					
		7.1		Jan 21/2005					
30-71-24		1		Jan 21/2005					
		2		Jan 21/2005					
		3		Jan 21/2005					
		4		Jan 21/2005					
30-71-25		1		Jan 21/2005					
30-81-11		1.1	1	Jan 21/2005					
			2	Jan 21/2005					
			3	Jan 21/2005					
		2	1	Jan 21/2005					
			2	Jan 21/2005					
		3.1	1	Jan 21/2005					
			2	Jan 21/2005					
			3	Jan 21/2005					
		4.1	1	Jan 21/2005					
			2	Jan 21/2005					

A = Added, R = Revised, D = Deleted, O = Overflow

30-EFFECTIVE PAGES

Page 2
Aug 05/2009

D280T132



767-200/300

WIRING DIAGRAM MANUAL

CHAPTER 30
ICE AND RAIN PROTECTION

Title	CH-SC-SU	Schem	Page	Sheet	Date	Effectivity
<u>WING THERMAL ANTI-ICING</u>						
WING THERMAL ANTI-ICE	30-11-11		1	1	Jan 21/2005	050-099
				2	Jan 21/2005	050-099
			2	1	Jan 21/2005	150-154 275-299
				2	Jan 21/2005	150-154 275-299
			2.1	1	Jan 21/2005	150-154
				2	Jan 21/2005	150-154
			3.1	1	Jan 21/2005	155
				2	Jan 21/2005	155
			4	1	Jan 21/2005	156-199
				2	Jan 21/2005	156-199
<u>ENGINE INLET THERMAL ANTI-ICING</u>						
ENGINE INLET THERMAL ANTI-ICE	30-21-11		1	1	Jan 21/2005	050-099 155-199
				2	Jan 21/2005	050-099 155-199
				3	Jan 21/2005	050-099 155-199
			2	1	Jan 21/2005	150-154
				2	Jan 21/2005	150-154
			2.1	1	Jan 21/2005	150-154
				2	Jan 21/2005	150-154
				3	Jan 21/2005	150-154
			3	1	Jan 21/2005	275-299
				2	Jan 21/2005	275-299
<u>PITOT STATIC PROBE ANTI-ICING</u>						
PROBE HEAT- CAPTAINS PITOT STATIC	30-31-11		1.1		Mar 09/2006	050-280
PROBE HEAT- RIGHT AUXILIARY PITOT STATIC	30-31-13		1.1		Mar 09/2006	050-280
PROBE HEAT- FIRST OFFICER- PITOT STATIC	30-31-21		1		Aug 05/2009	ALL
PROBE HEAT- LEFT AUXILIARY PITOT STATIC	30-31-23		1		Jan 21/2005	050-099
				2	Jan 21/2005	150-199 275-299

30-CONTENTS



767-200/300

WIRING DIAGRAM MANUAL

**CHAPTER 30
ICE AND RAIN PROTECTION**

Title	CH-SC-SU	Schem	Page	Sheet	Date	Effectivity
<u>ANGLE-OF-ATTACK PROBE HEAT</u>						
PROBE HEAT- ANGLE OF ATTACK- LEFT	30-32-11		1		Jan 21/2005	ALL
PROBE HEAT- ANGLE OF ATTACK- RIGHT	30-32-21		1		Jan 21/2005	ALL
<u>TOTAL AIR TEMPERATURE PROBE HEAT</u>						
PROBE HEAT- TOTAL AIR TEMPERATURE- LEFT	30-33-11		1		Jan 21/2005	ALL
<u>ENGINE PROBE HEAT</u>						
PROBE HEAT- ENGINE TT2- LEFT	30-34-11		1.1		Mar 09/2006	050 150 152-280
			2.1		Mar 09/2006	051 151
PROBE HEAT- ENGINE TT2- RIGHT	30-34-21		1		Jan 21/2005	050-099 150-199
			2		Jan 21/2005	275-299
<u>FLIGHT COMPARTMENT WINDOW ANTI-ICING</u>						
WINDOW HEAT- LEFT FORWARD & RIGHT SIDE	30-41-11		1	1	Jan 21/2005	050-099
				2	Jan 21/2005	050-099
				2.1	Jan 21/2005	150-154 275-276
				2	Jan 21/2005	150-154 275-276
				3	Jan 21/2005	155-199 277-299
WINDOW HEAT- RIGHT FORWARD & LEFT SIDE	30-41-12		1	1	Jan 21/2005	050-099
				2	Jan 21/2005	050-099
				2.1	Jan 21/2005	150-154 275-276
				2	Jan 21/2005	150-154 275-276
				3	Jan 21/2005	155-199 277-299
<u>WINDSHIELD WIPER SYSTEM</u>						
WINDSHIELD WIPERS	30-42-11		1		Jan 21/2005	ALL
<u>WINDSHIELD RAIN REPELLENT SYSTEM</u>						
WINDSHIELD RAIN REPELLENT	30-43-11		1.1		Jan 21/2005	050-167
			2		Jan 21/2005	275-278

30-CONTENTS



767-200/300

WIRING DIAGRAM MANUAL

**CHAPTER 30
ICE AND RAIN PROTECTION**

Title	CH-SC-SU	Schem	Page	Sheet	Date	Effectivity
WINDSHIELD RAIN REPELLENT (cont.)	30-43-11		3		Jan 21/2005	280-299
<u>ENTRY/SERVICE DOOR VIEWPORT HEATER</u>						
VIEWPORT HEATERS ENTRY/SERVICE DOORS	30-46-11		1		Jan 21/2005	ALL
<u>WATER AND DRAIN LINE HEATERS</u>						
DRAIN MAST HEATING	30-71-11		1		Jan 21/2005	050-099
			2		Jan 21/2005	150-199 275-278
			3		Jan 21/2005	280-299
FORWARD WATER SUPPLY LINE & DRAIN LINE HEATERS	30-71-21		1	1	Jan 21/2005	050-099
				2	Jan 21/2005	050-099
			2	1	Jan 21/2005	150-154
				2	Jan 21/2005	150-154
			3	1	Jan 21/2005	155-199
				2	Jan 21/2005	155-199
			4		Jan 21/2005	275
			5		Jan 21/2005	276
			6		Jan 21/2005	277-278
			7		Jan 21/2005	280-299
MID WATER SUPPLY LINE & DRAIN LINE HEATERS	30-71-22		1		Jan 21/2005	050-099
			2		Jan 21/2005	150-154
			3		Jan 21/2005	155-199
			4		Jan 21/2005	275
			5		Jan 21/2005	276-299
AFT WATER SUPPLY LINE & DRAIN LINE HEATERS	30-71-23		1		Jan 21/2005	050-099
			1.1		Jan 21/2005	050-051
			2		Jan 21/2005	150-154
			2.1		Jan 21/2005	150-154
			3		Jan 21/2005	155-199
			3.1		Jan 21/2005	155-167
			4		Jan 21/2005	275

30-CONTENTS



767-200/300

WIRING DIAGRAM MANUAL

**CHAPTER 30
ICE AND RAIN PROTECTION**

Title	CH-SC-SU	Schem	Page	Sheet	Date	Effectivity
AFT WATER SUPPLY LINE & DRAIN LINE HEATERS (cont.)	30-71-23		4.1		Jan 21/2005	275
			5		Jan 21/2005	276
			5.1		Jan 21/2005	276
			6		Jan 21/2005	277-278
			6.1		Jan 21/2005	277-278
			7		Jan 21/2005	280-299
			7.1		Jan 21/2005	280
		AFT WATER SUPPLY LINE & WATER TANK HEATERS	30-71-24		1	
	2				Jan 21/2005	051-099
	3				Jan 21/2005	150-154
	4				Jan 21/2005	155-199
	1				Jan 21/2005	050-099 150-199
GALLEY WATER SUPPLY LINE & SUPPLY LINE HEATERS	30-71-25		1		Jan 21/2005	050-099 150-199
<u>ICE DETECTION SYSTEM</u>						
AUTOMATIC-ICE DETECTOR	30-81-11		1.1	1	Jan 21/2005	050 155-167
				2	Jan 21/2005	050 155-167
				3	Jan 21/2005	050 155-167
			2	1	Jan 21/2005	051-099
				2	Jan 21/2005	051-099
			3.1	1	Jan 21/2005	150 152-154
				2	Jan 21/2005	150 152-154
				3	Jan 21/2005	150 152-154
			4.1	1	Jan 21/2005	151
				2	Jan 21/2005	151



767-200/300

WIRING DIAGRAM MANUAL

CHAPTER 30 ICE AND RAIN PROTECTION

CH-SC-SU	Title
30-71-23	AFT WATER SUPPLY LINE & DRAIN LINE HEATERS
30-71-24	AFT WATER SUPPLY LINE & WATER TANK HEATERS
30-81-11	AUTOMATIC-ICE DETECTOR
30-71-11	DRAIN MAST HEATING
30-21-11	ENGINE INLET THERMAL ANTI-ICE
30-71-21	FORWARD WATER SUPPLY LINE & DRAIN LINE HEATERS
30-71-25	GALLEY WATER SUPPLY LINE & SUPPLY LINE HEATERS
30-71-22	MID WATER SUPPLY LINE & DRAIN LINE HEATERS
30-32-11	PROBE HEAT- ANGLE OF ATTACK- LEFT
30-32-21	PROBE HEAT- ANGLE OF ATTACK- RIGHT
30-31-11	PROBE HEAT- CAPTAINS PITOT STATIC
30-34-11	PROBE HEAT- ENGINE TT2- LEFT
30-34-21	PROBE HEAT- ENGINE TT2- RIGHT
30-31-21	PROBE HEAT- FIRST OFFICER- PITOT STATIC
30-31-23	PROBE HEAT- LEFT AUXILIARY PITOT STATIC
30-31-13	PROBE HEAT- RIGHT AUXILIARY PITOT STATIC
30-33-11	PROBE HEAT- TOTAL AIR TEMPERATURE- LEFT
30-46-11	VIEWPORT HEATERS ENTRY/SERVICE DOORS
30-41-11	WINDOW HEAT- LEFT FORWARD & RIGHT SIDE
30-41-12	WINDOW HEAT- RIGHT FORWARD & LEFT SIDE
30-43-11	WINDSHIELD RAIN REPELLENT
30-42-11	WINDSHIELD WIPERS
30-11-11	WING THERMAL ANTI-ICE

30-ALPHABETICAL INDEX

D280T132

Page 1
Jan 21/2005

-B

15

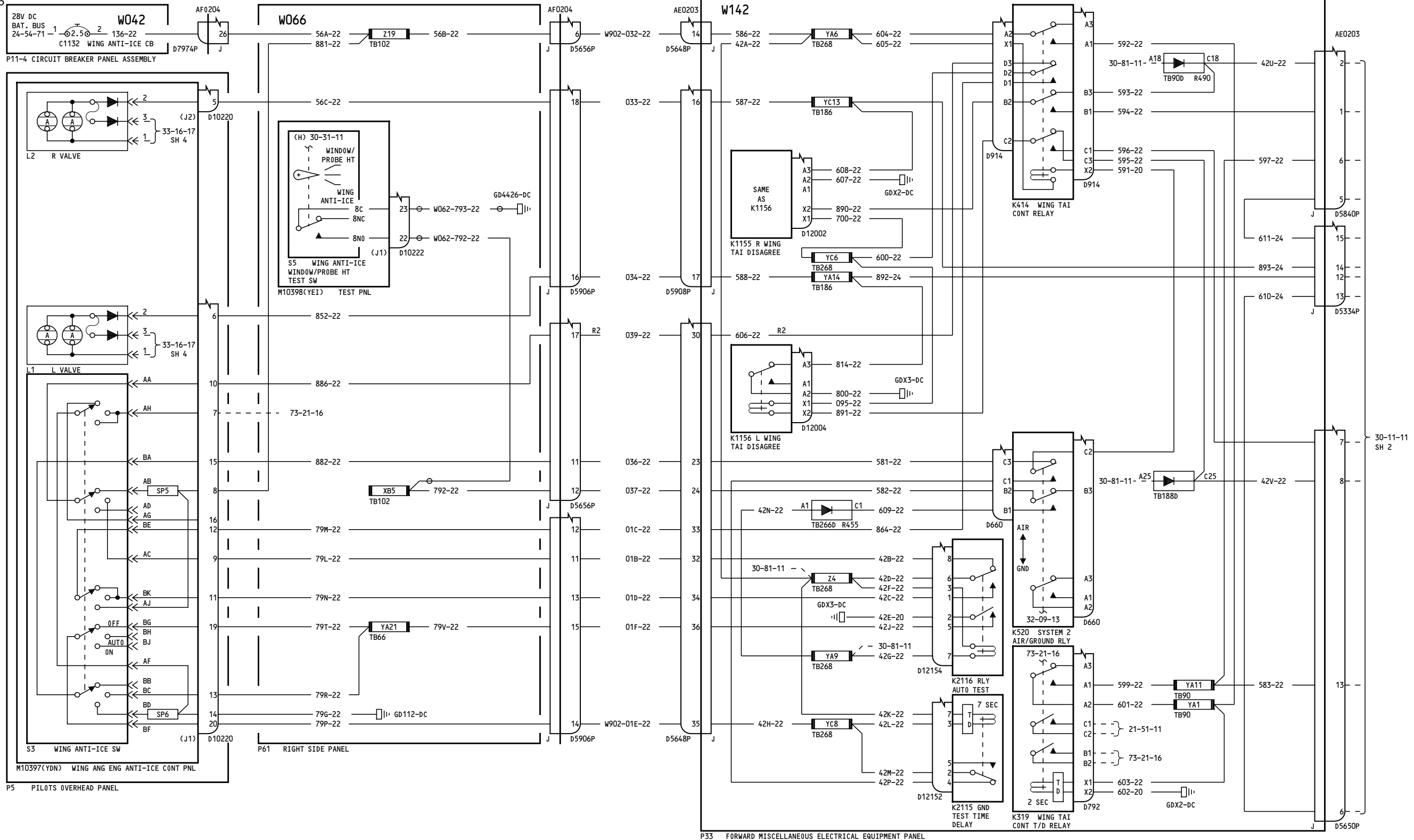

050-099

WING THERMAL ANTI-ICE

30-11-11

Page 1
Sheet 1
Jan 21/2005

D280T132

30-11-11

Page 1
Sheet 1
Jan 21/2005

-C
15

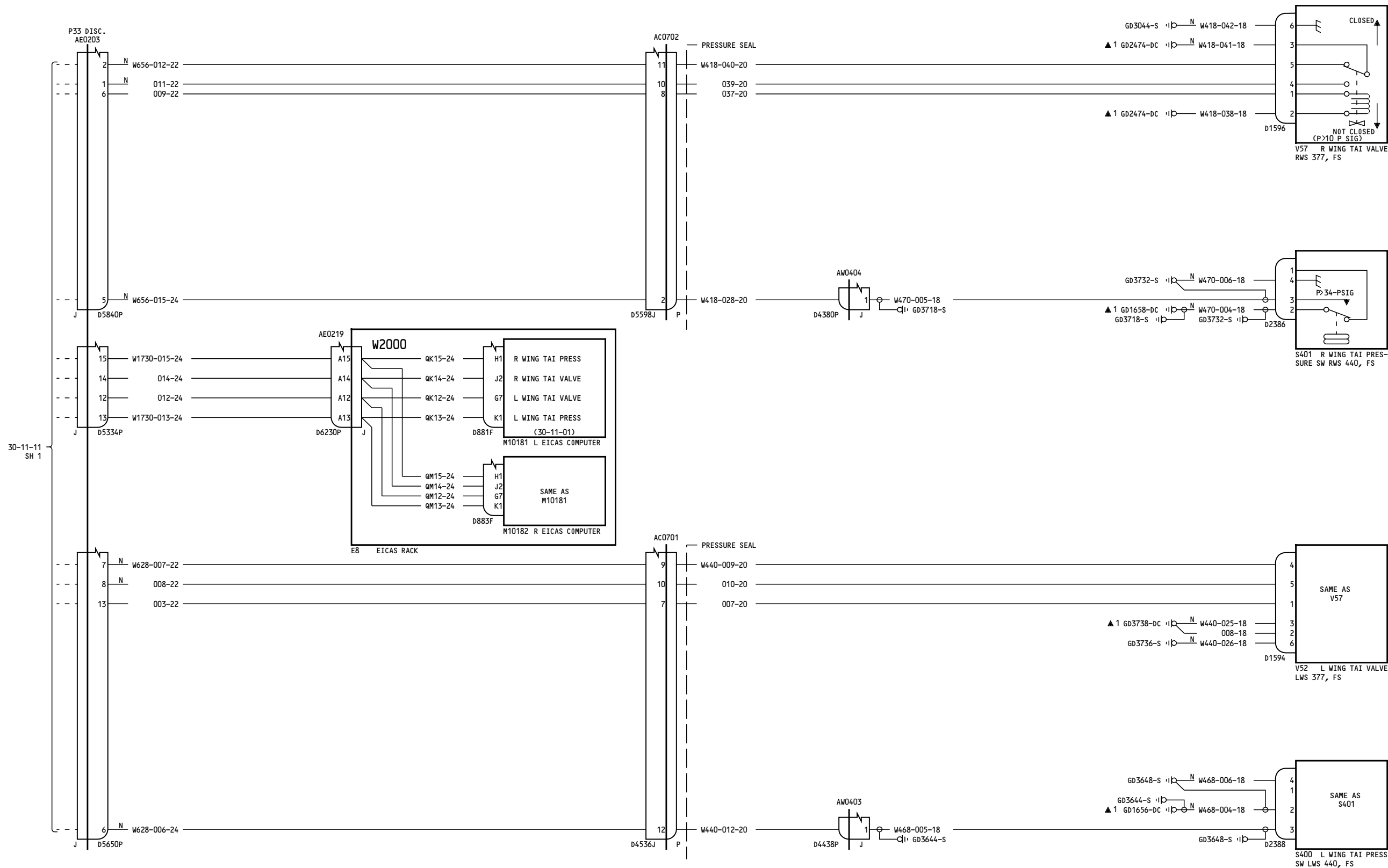

050-099

WING THERMAL ANTI-ICE

30-11-11

Page 1
Sheet 2
Jan 21/2005

D280T132

30-11-11

Page 1
Sheet 2
Jan 21/2005

-D

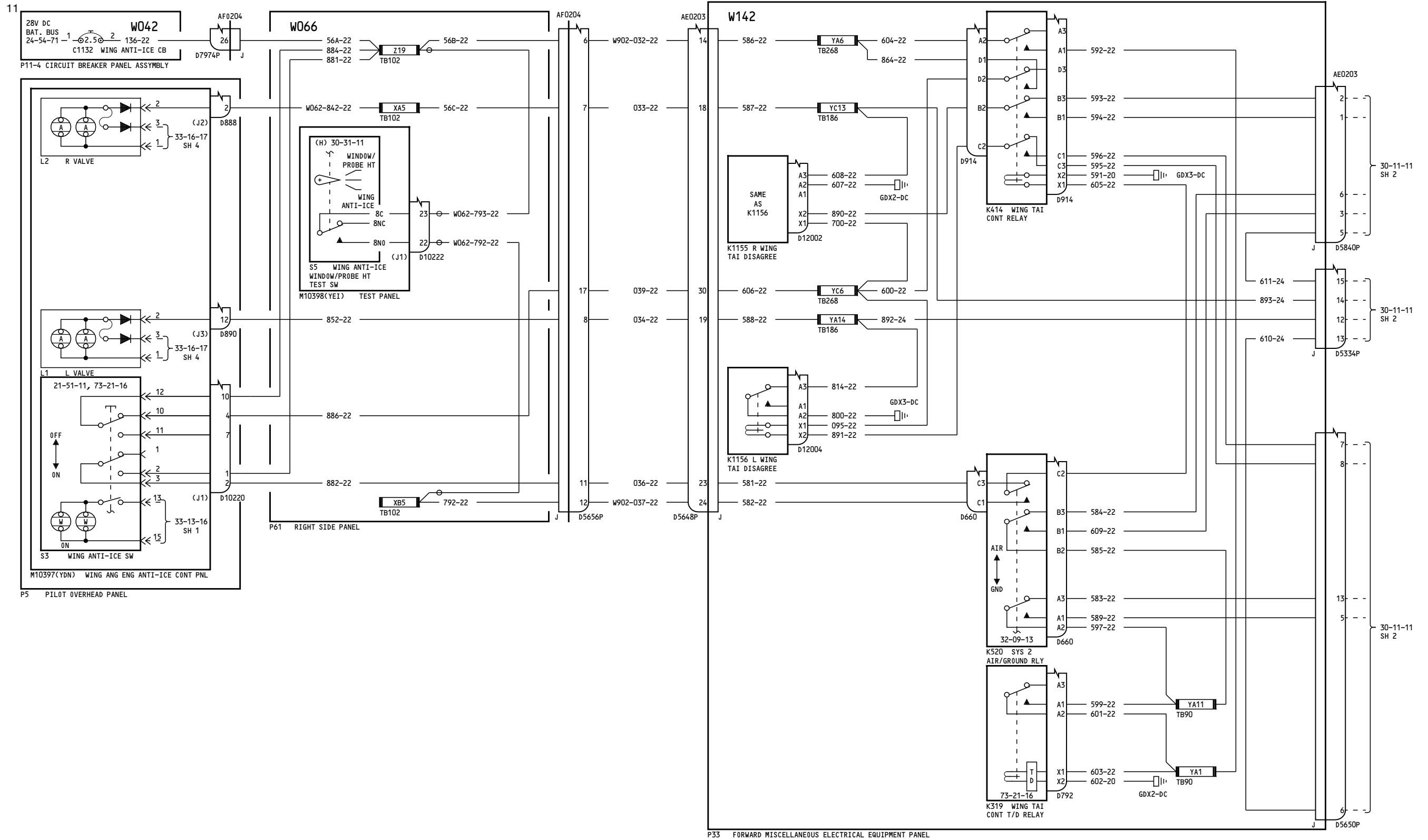

150-154, 275-299

WING THERMAL ANTI-ICE

30-11-11

Page 2
Sheet 1
Jan 21/2005

D280T132

30-11-11

Page 2
Sheet 1
Jan 21/2005

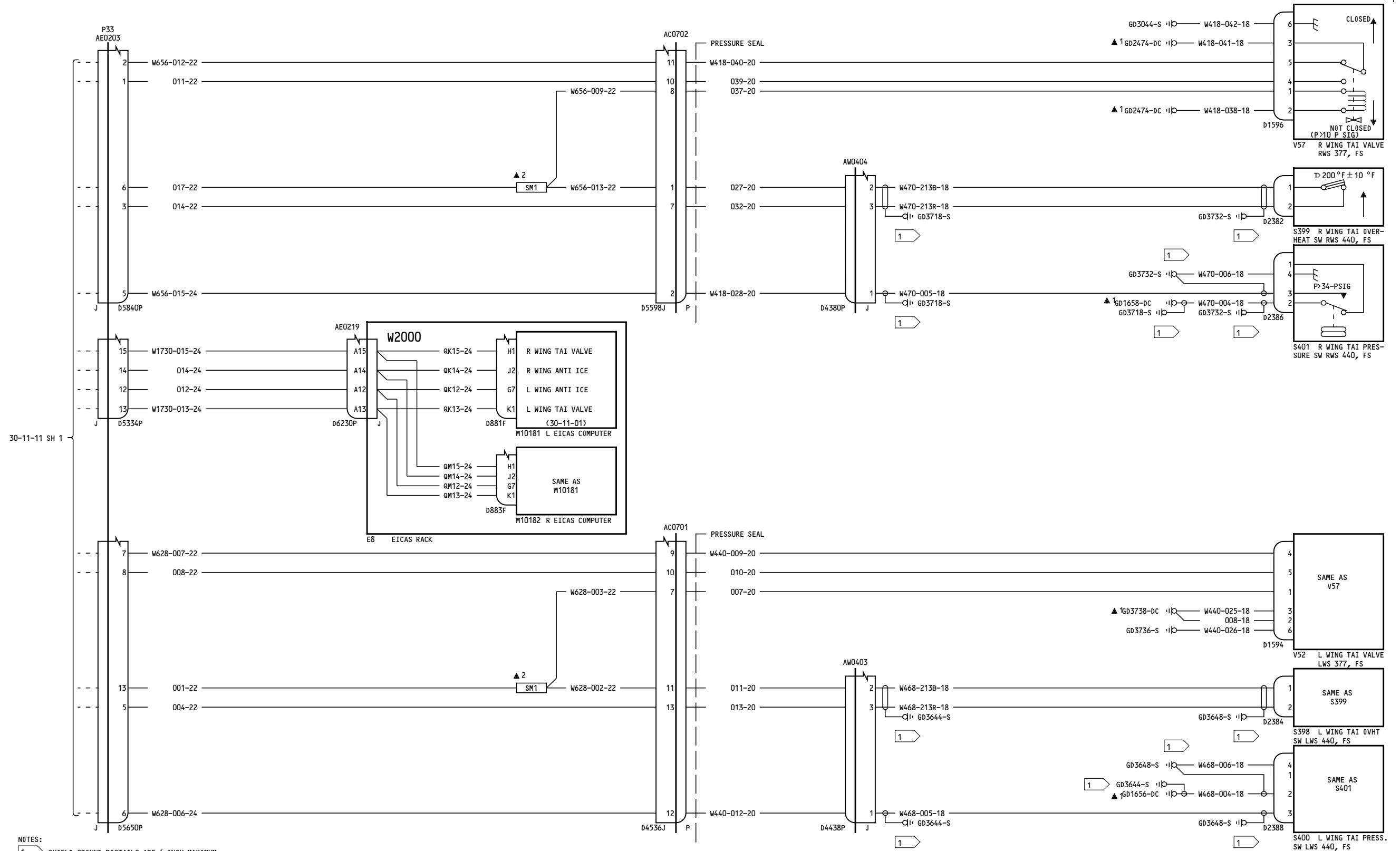

NOTES:
1 SHIELD GROUND PIGTAILS ARE 6 INCH MAXIMUM

150-154, 275-299

WING THERMAL ANTI-ICE

D280T132

30-11-11

Page 2
Sheet 2
Jan 21/2005

30-11-11

Page 2
Sheet 2
Jan 21/2005

-A

25

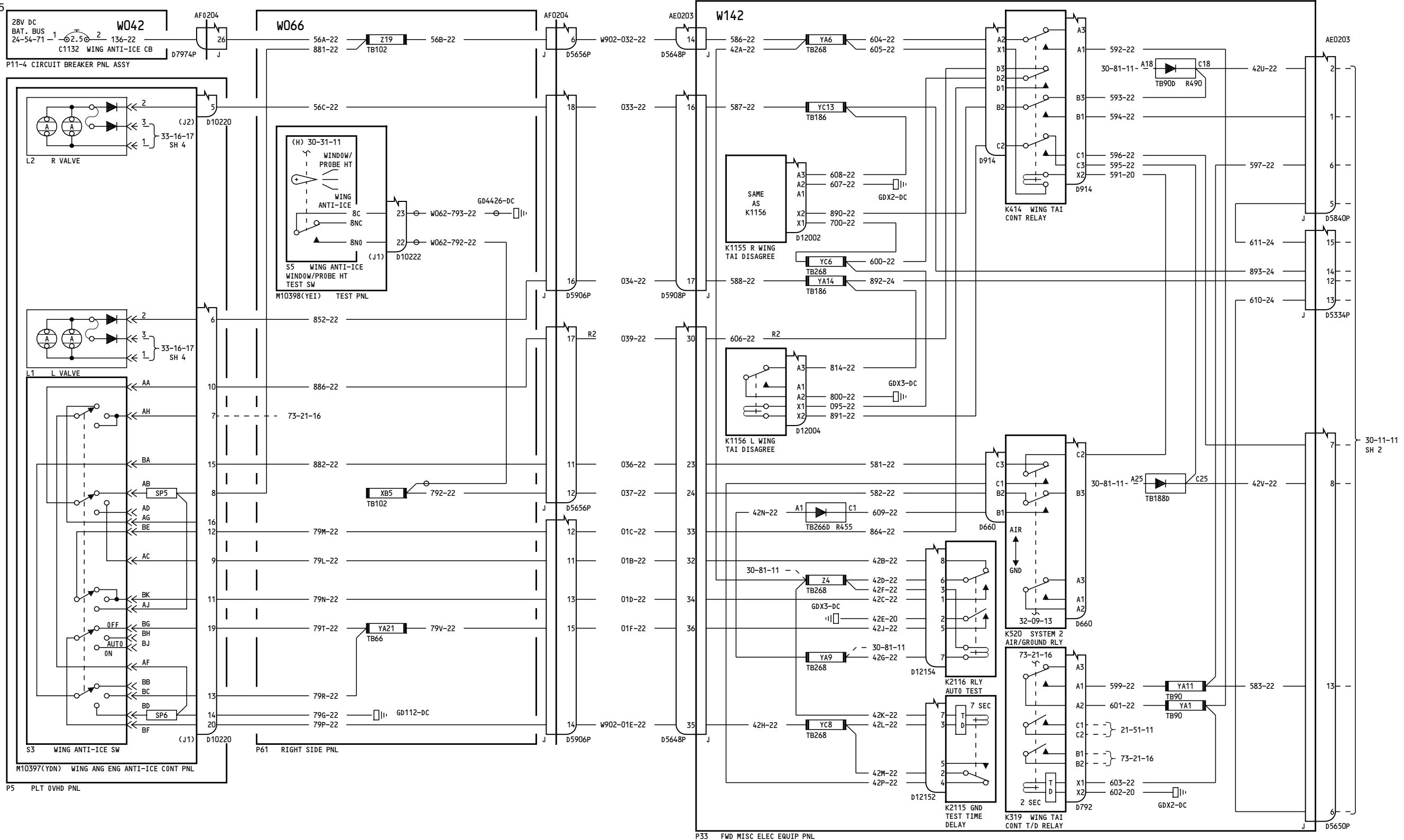

150-154

WING THERMAL ANTI-ICE

30-11-11

Incorporates 30-0017

D280T132

30-11-11

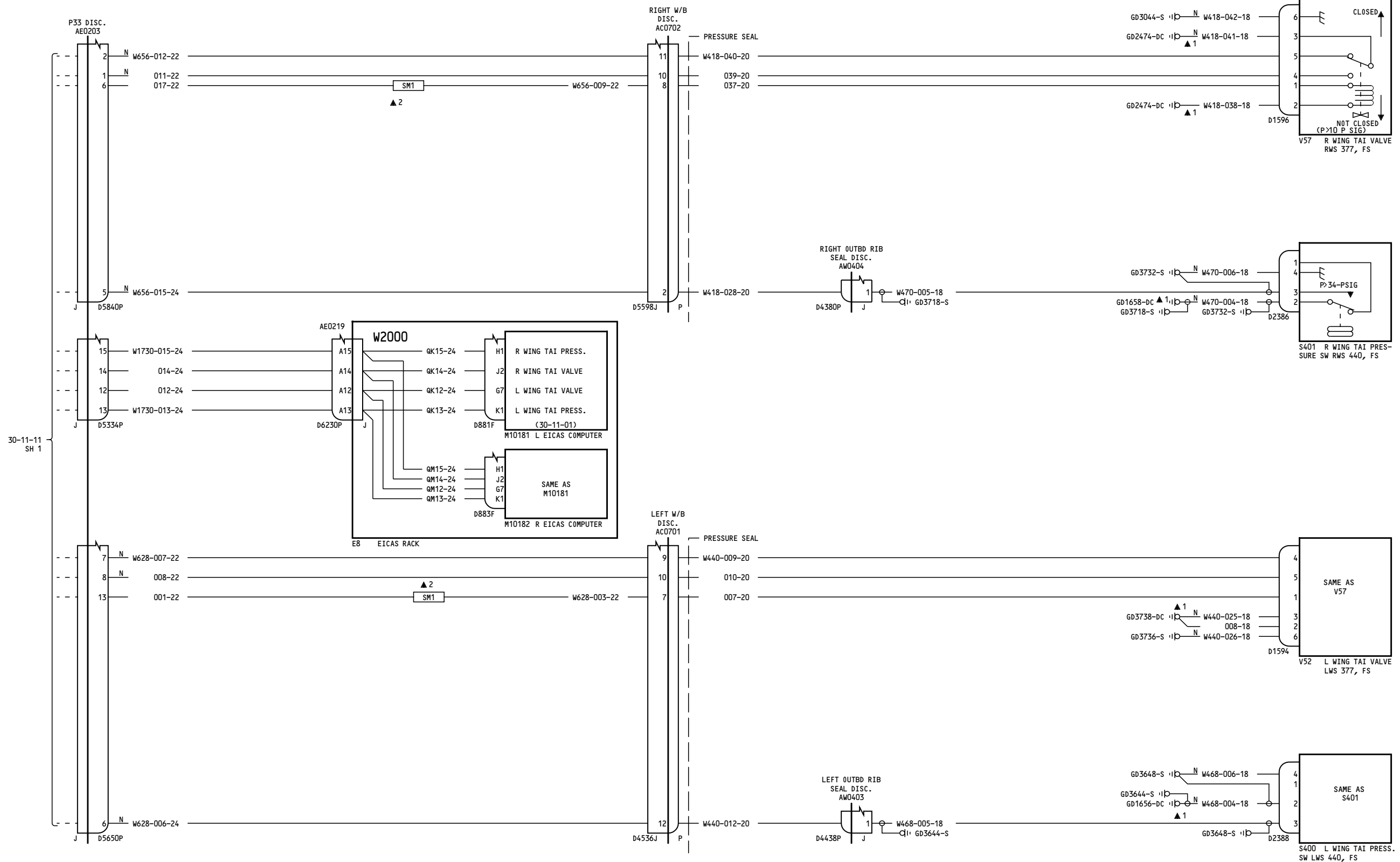

150-154

WING THERMAL ANTI-ICE

30-11-11

Page 2.1
Sheet 2
Jan 21/2005

D280T132

Incorporates
▶ 30-0017

30-11-11

Page 2.1
Sheet 2
Jan 21/2005

-A

33

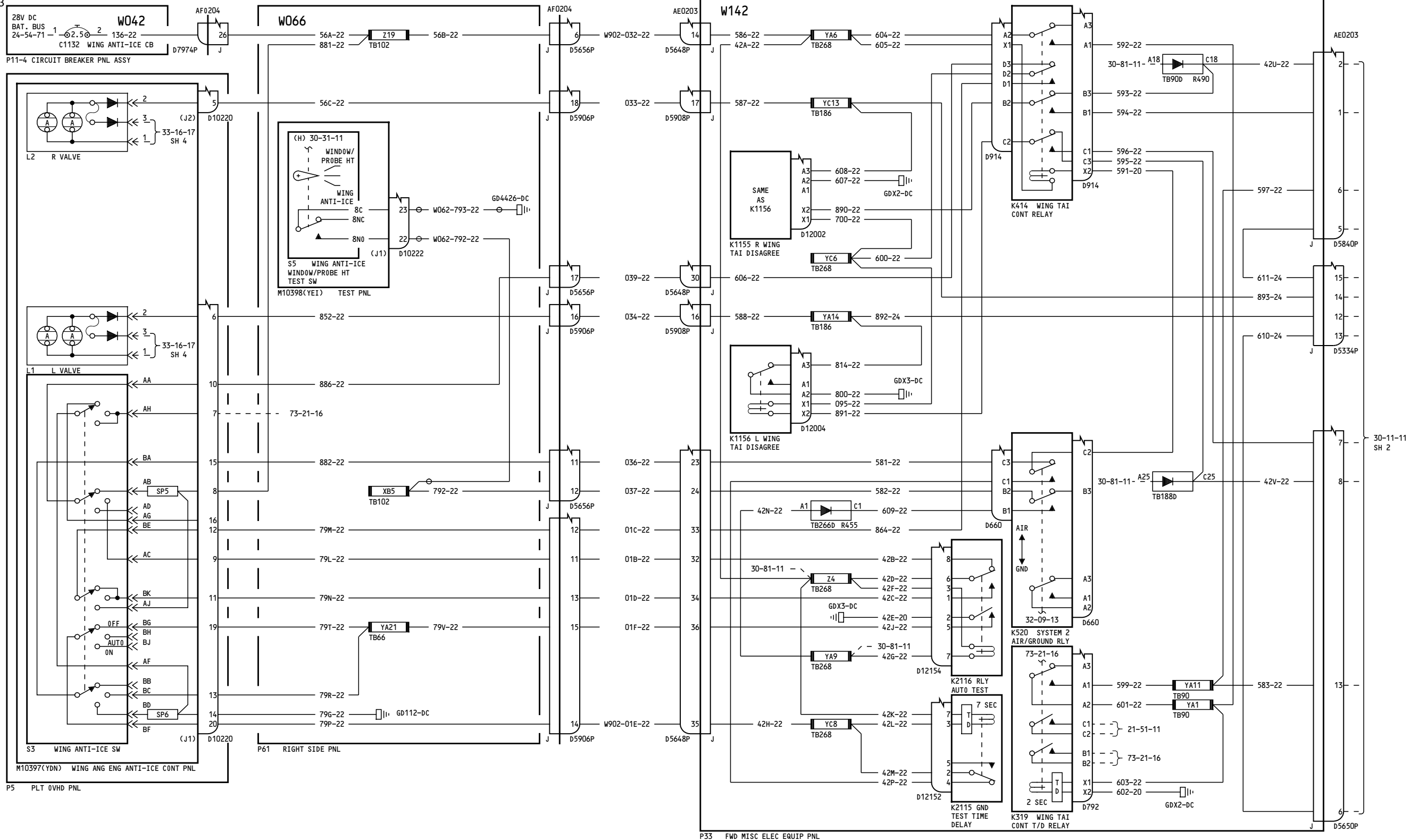

155

WING THERMAL ANTI-ICE

30-11-11

Page 3.1
Sheet 1
Jan 21/2005

D280T132

Incorporates
30-0021 R05

30-11-11

Page 3.1
Sheet 1
Jan 21/2005

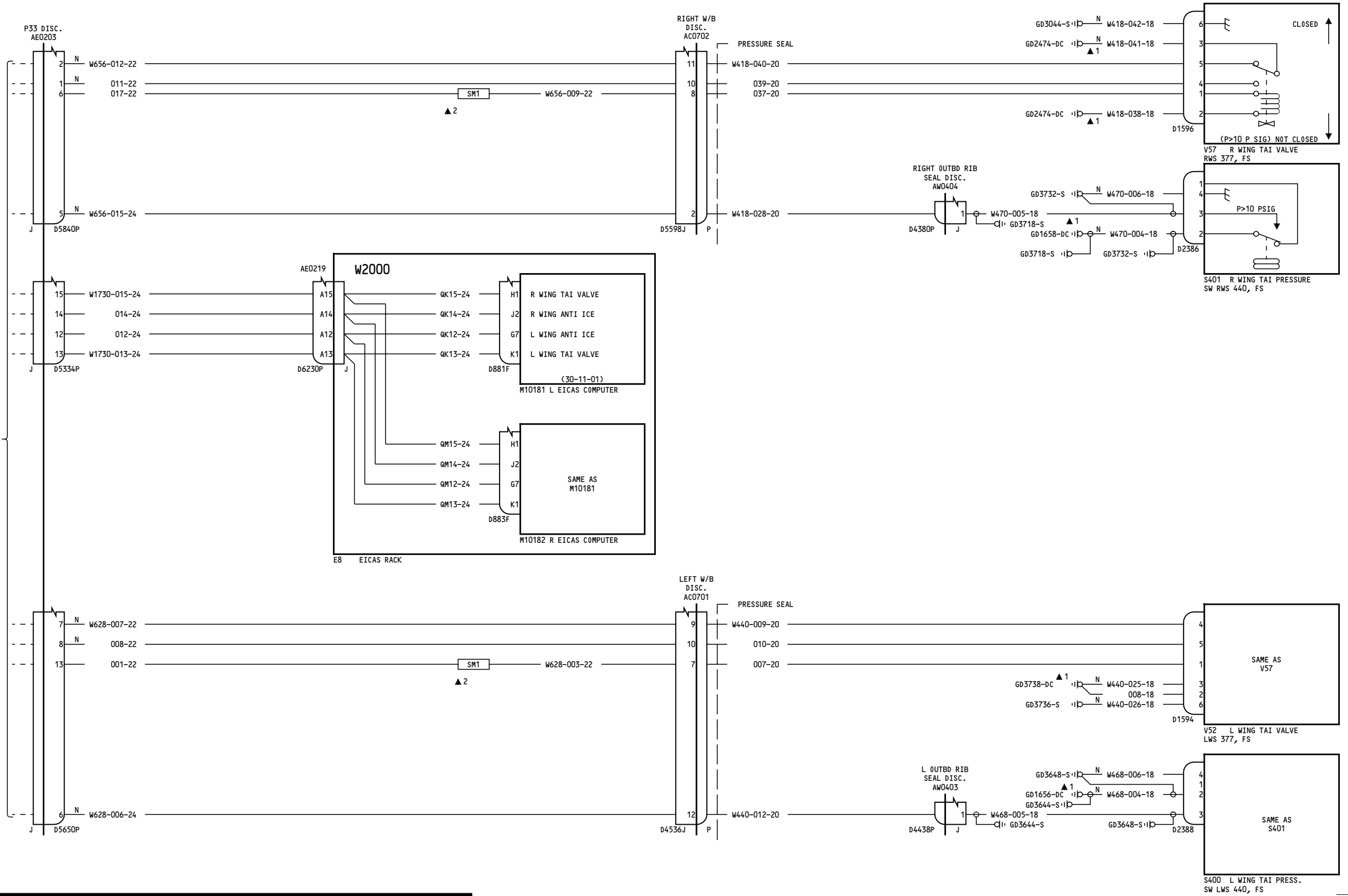

-B

15

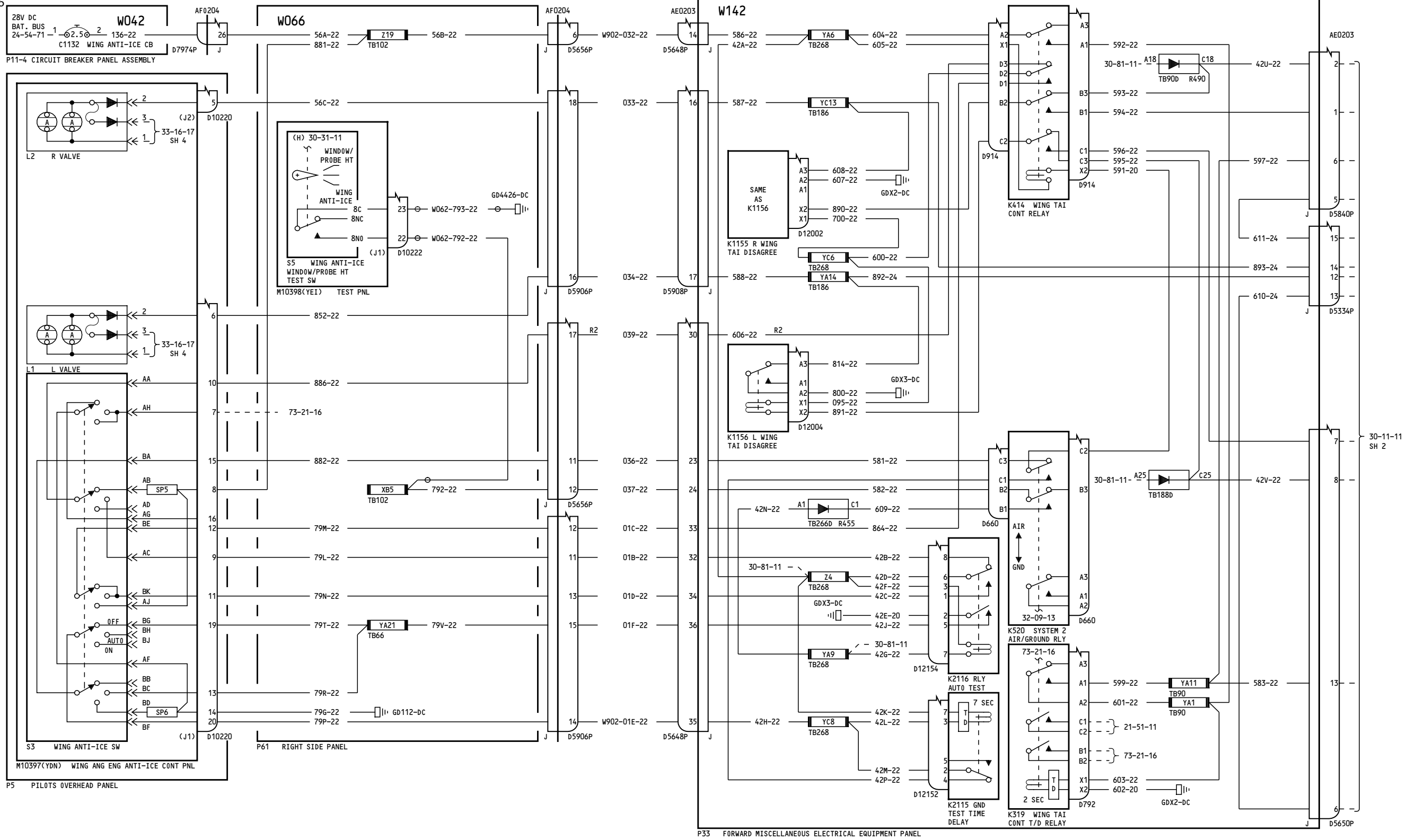

156-199

WING THERMAL ANTI-ICE

30-11-11

D280T132

30-11-11

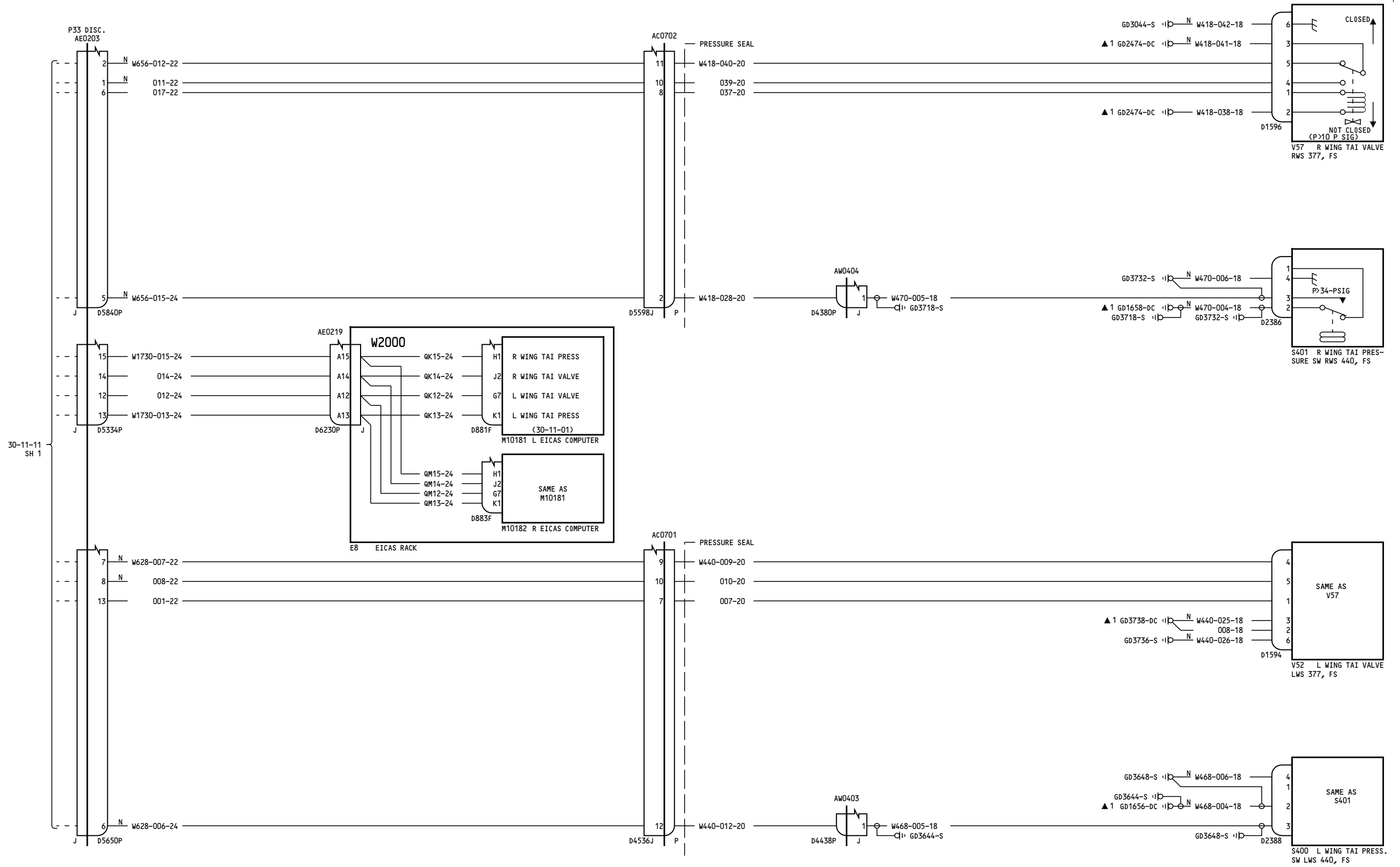

156-199

WING THERMAL ANTI-ICE

30-11-11

Page 4
Sheet 2
Jan 21/2005

D280T132

30-11-11

Page 4
Sheet 2
Jan 21/2005

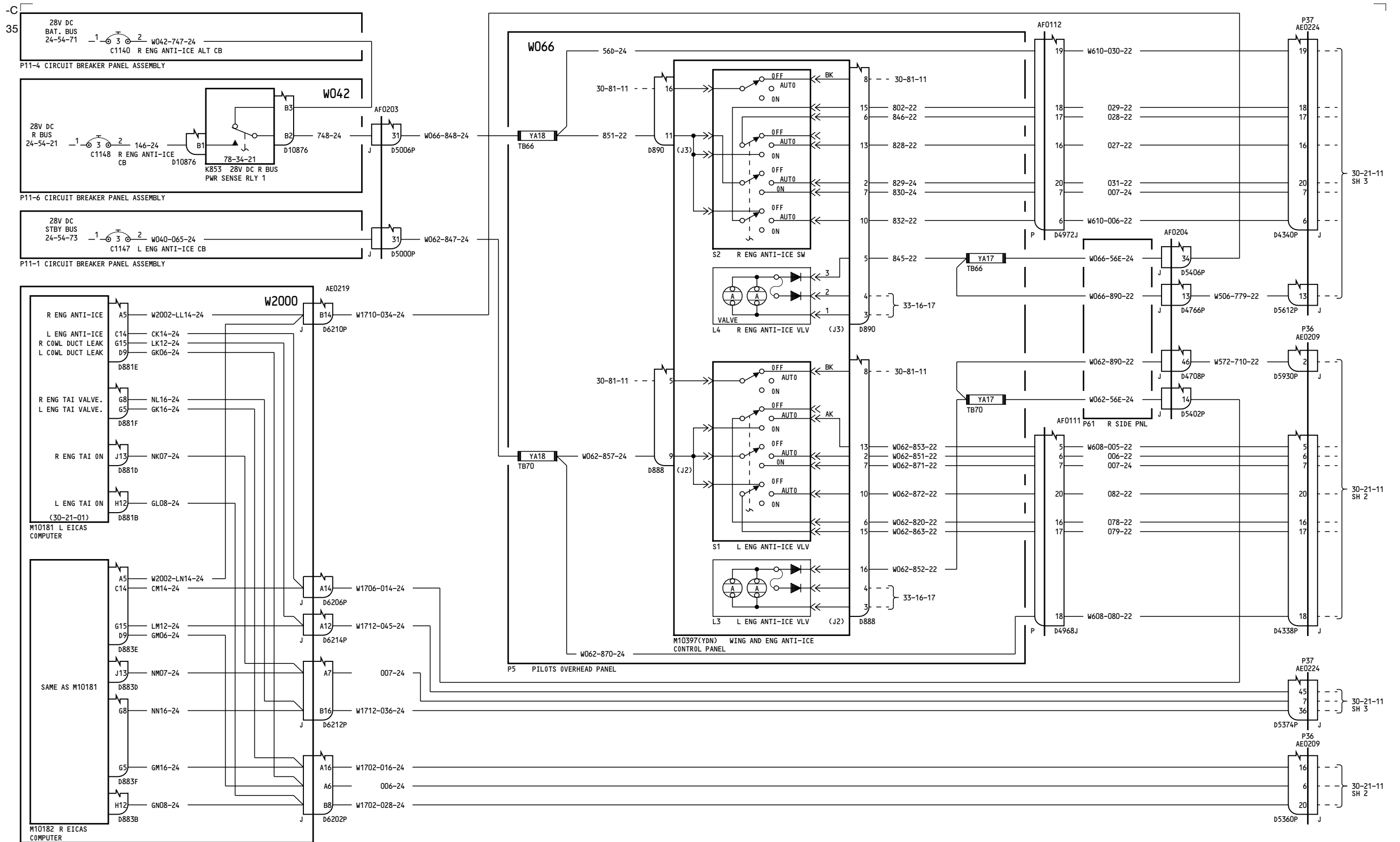

050-099, 155-199

ENGINE INLET THERMAL ANTI-ICE

D280T132

30-21-11

Page 1
Sheet 1
Jan 21/2005

30-21-11

Page 1
Sheet 1
Jan 21/2005

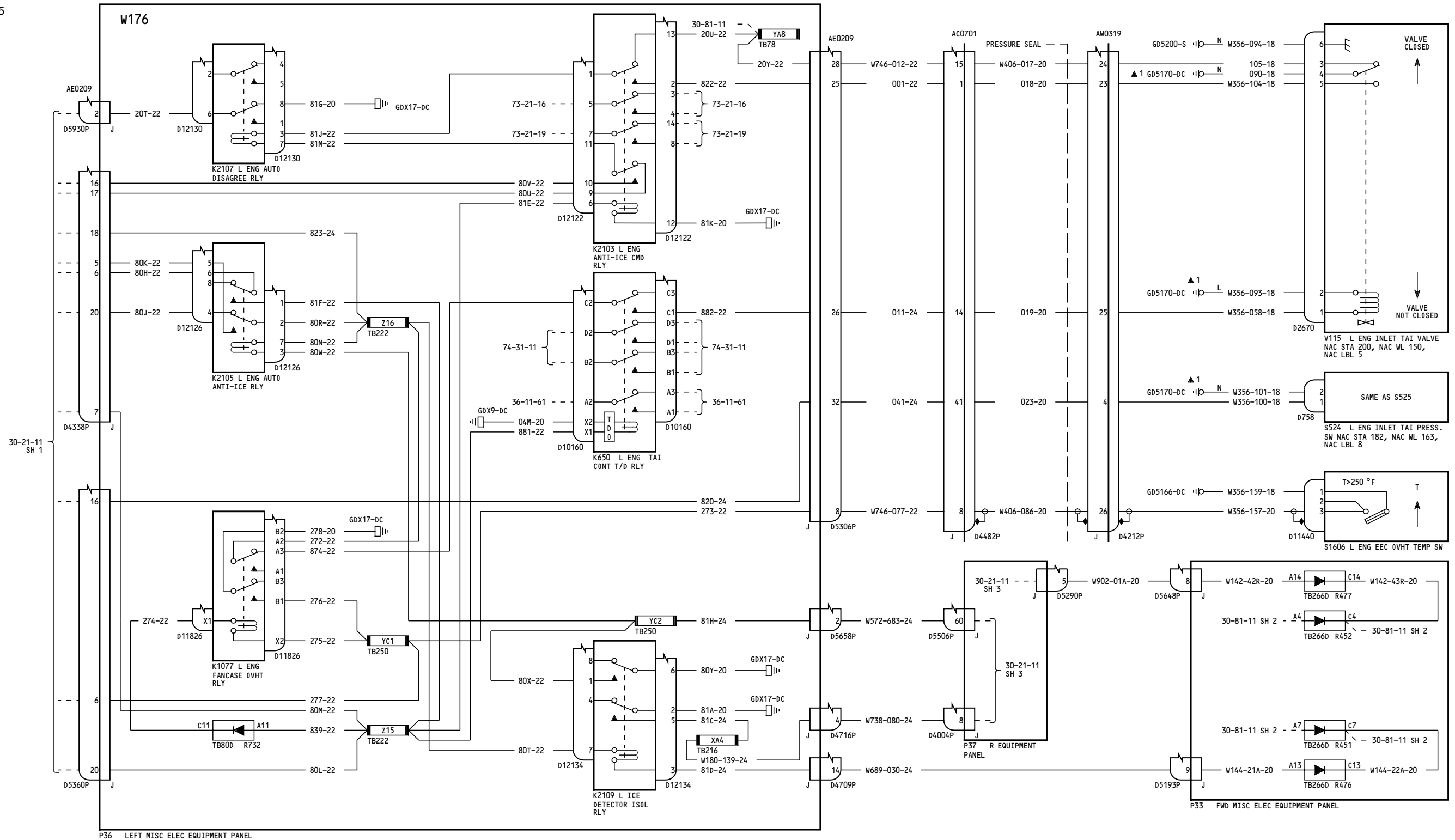

NOTE:
SHIELD PIGTAIL TO DISCONNECT BACKSHELL 2 INCHES MAXIMUM

050-099, 155-199

ENGINE INLET THERMAL ANTI-ICE

D280T132

30-21-11

Page 1
Sheet 2
Jan 21/2005

30-21-11

Page 1
Sheet 2
Jan 21/2005

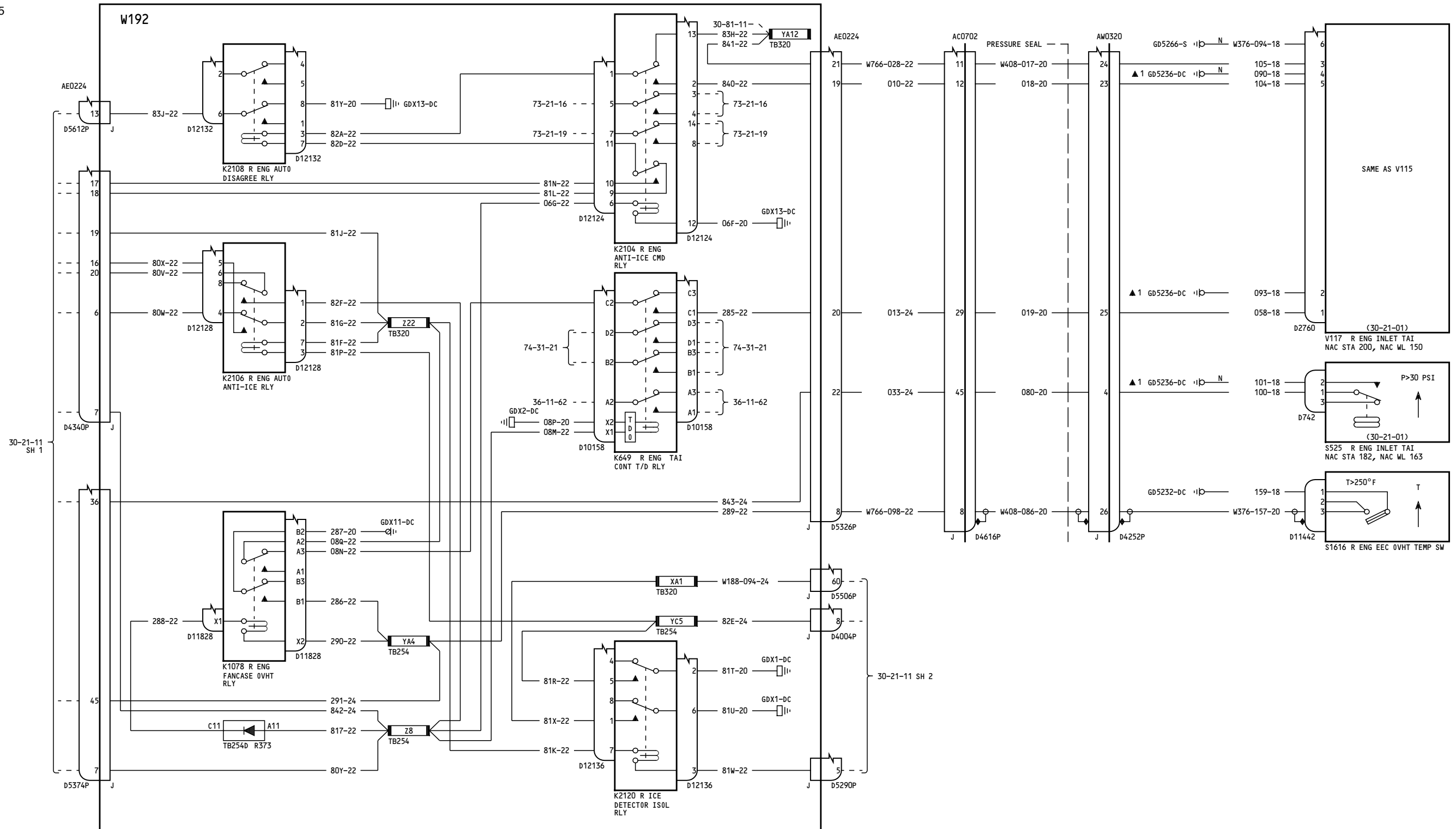

P37 RIGHT MISCELLANEOUS ELECTRICAL EQUIPMENT PANEL

NOTE:
SHIELD PIGTAIL TO DISCONNECT BACKSHELL 2 INCH MAXIMUM

050-099, 155-199

ENGINE INLET THERMAL ANTI-ICE

D280T132

30-21-11

Page 1
Sheet 3
Jan 21/2005

30-21-11

Page 1
Sheet 3
Jan 21/2005

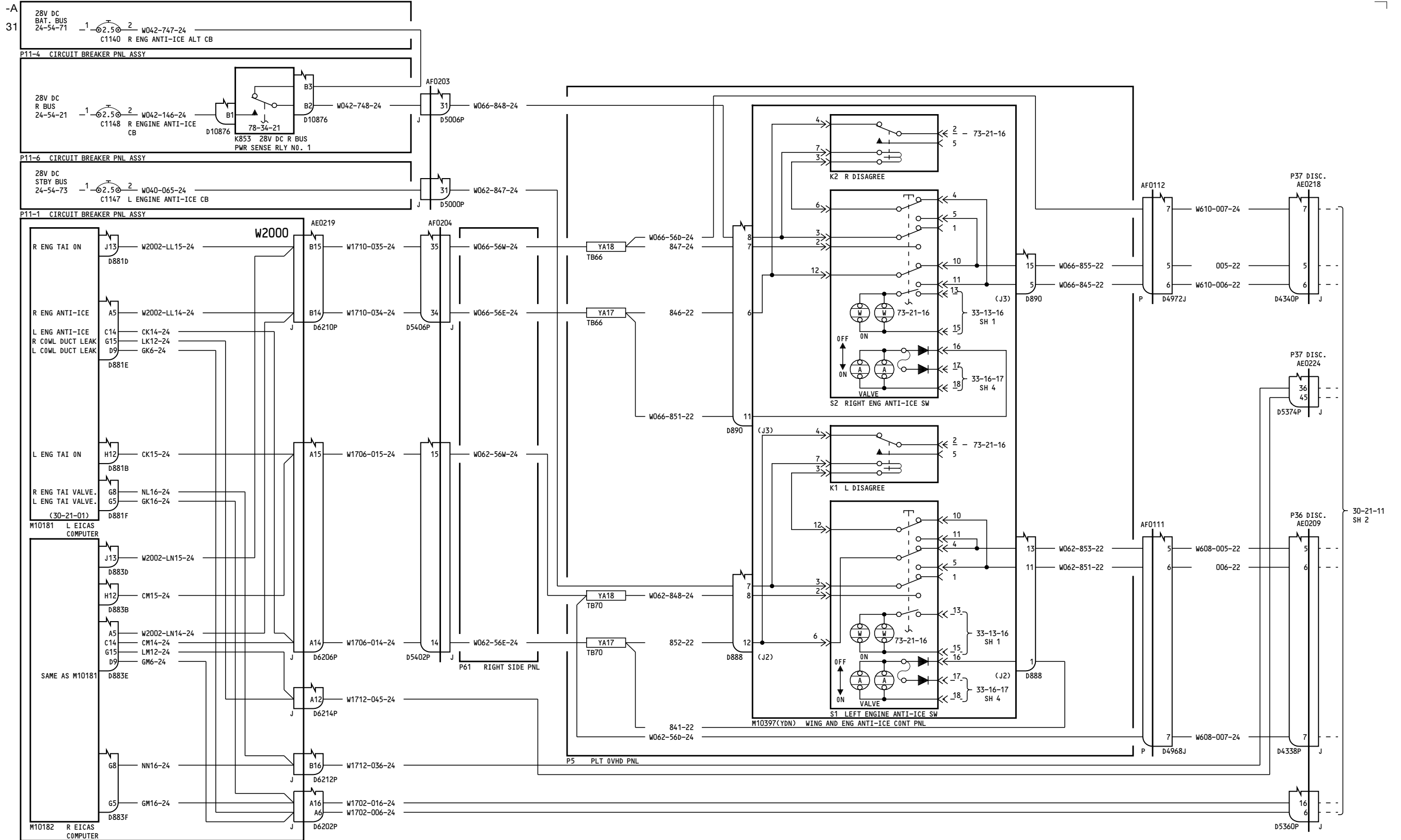

150-154

ENGINE INLET THERMAL ANTI-ICE

D280T132

30-21-11

30-21-11

BOEING PROPRIETARY - Copyright © - Unpublished Work - See title page for details.

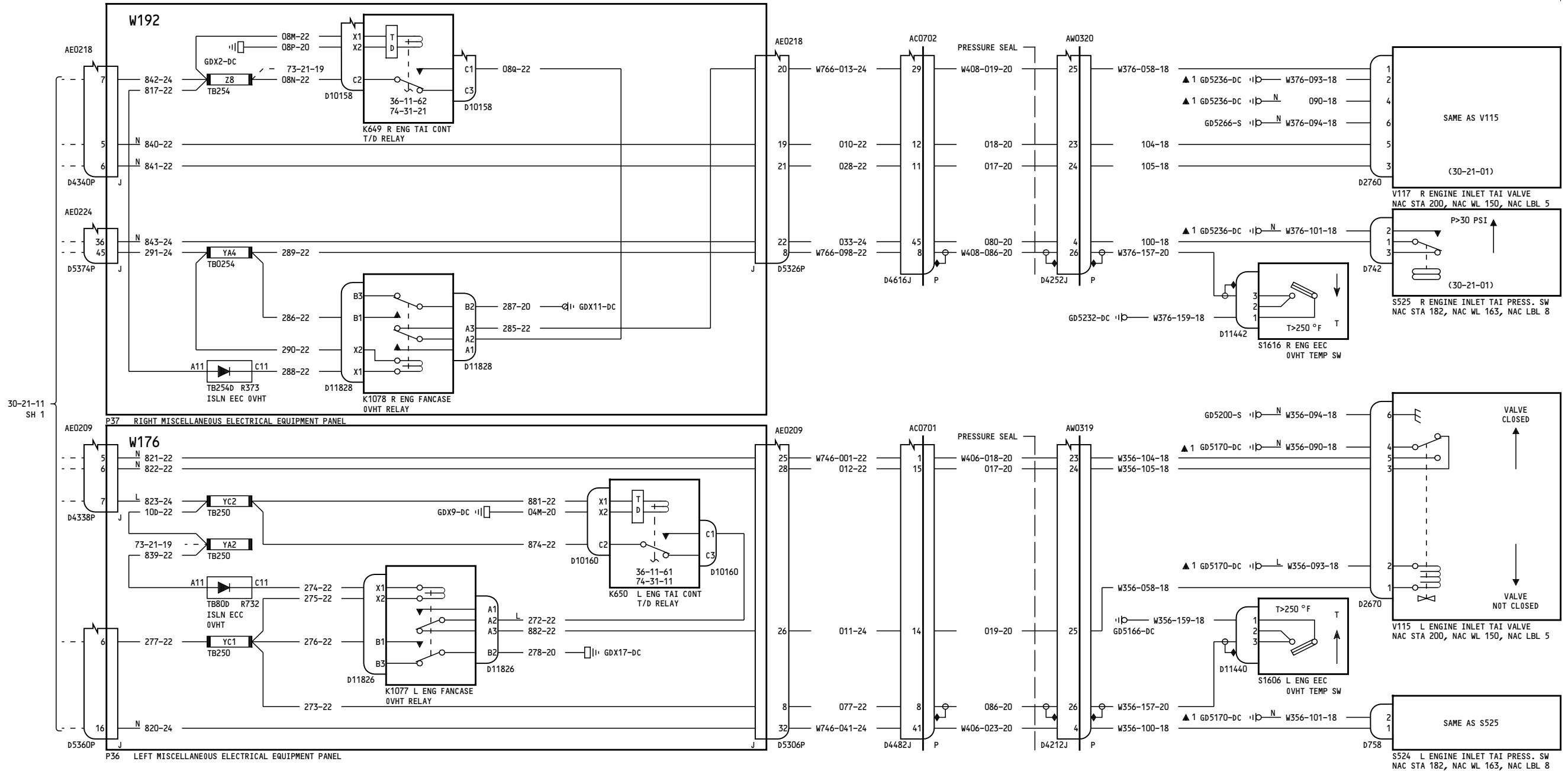

NOTES:
 SHIELD PIGTAIL TO DISCONNECT
 BACKSHELL 2 INCHES MAXIMUM

150-154

**ENGINE INLET THERMAL
 ANTI-ICE**

D280T132

30-21-11

Page 2
 Sheet 2
 Jan 21/2005

30-21-11

Page 2
 Sheet 2
 Jan 21/2005

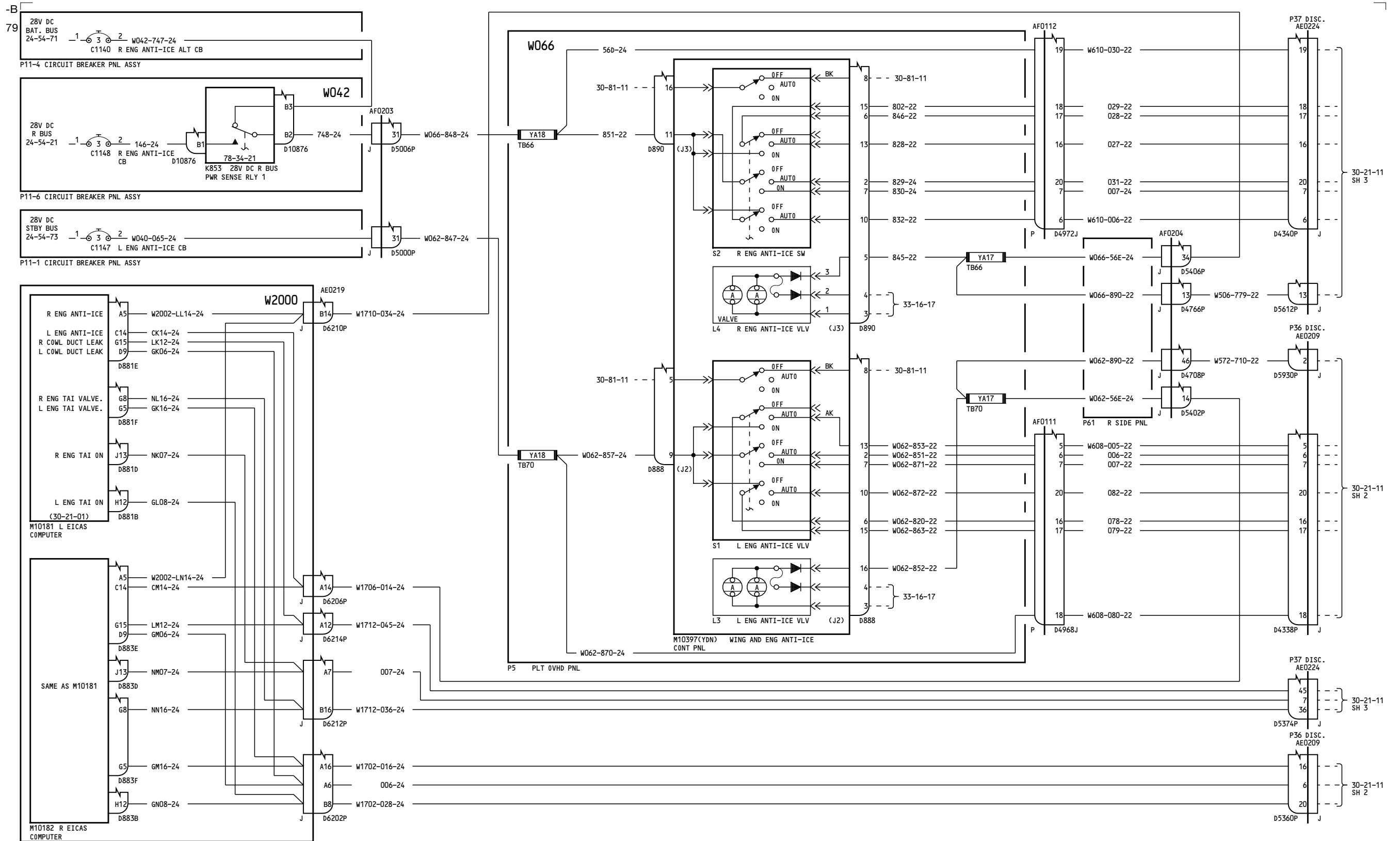

150-154

ENGINE INLET THERMAL ANTI-ICE

D280T132

30-21-11

Page 2.1
Sheet 1
Jan 21/2005

Incorporates
30-0017

30-21-11

Page 2.1
Sheet 1
Jan 21/2005

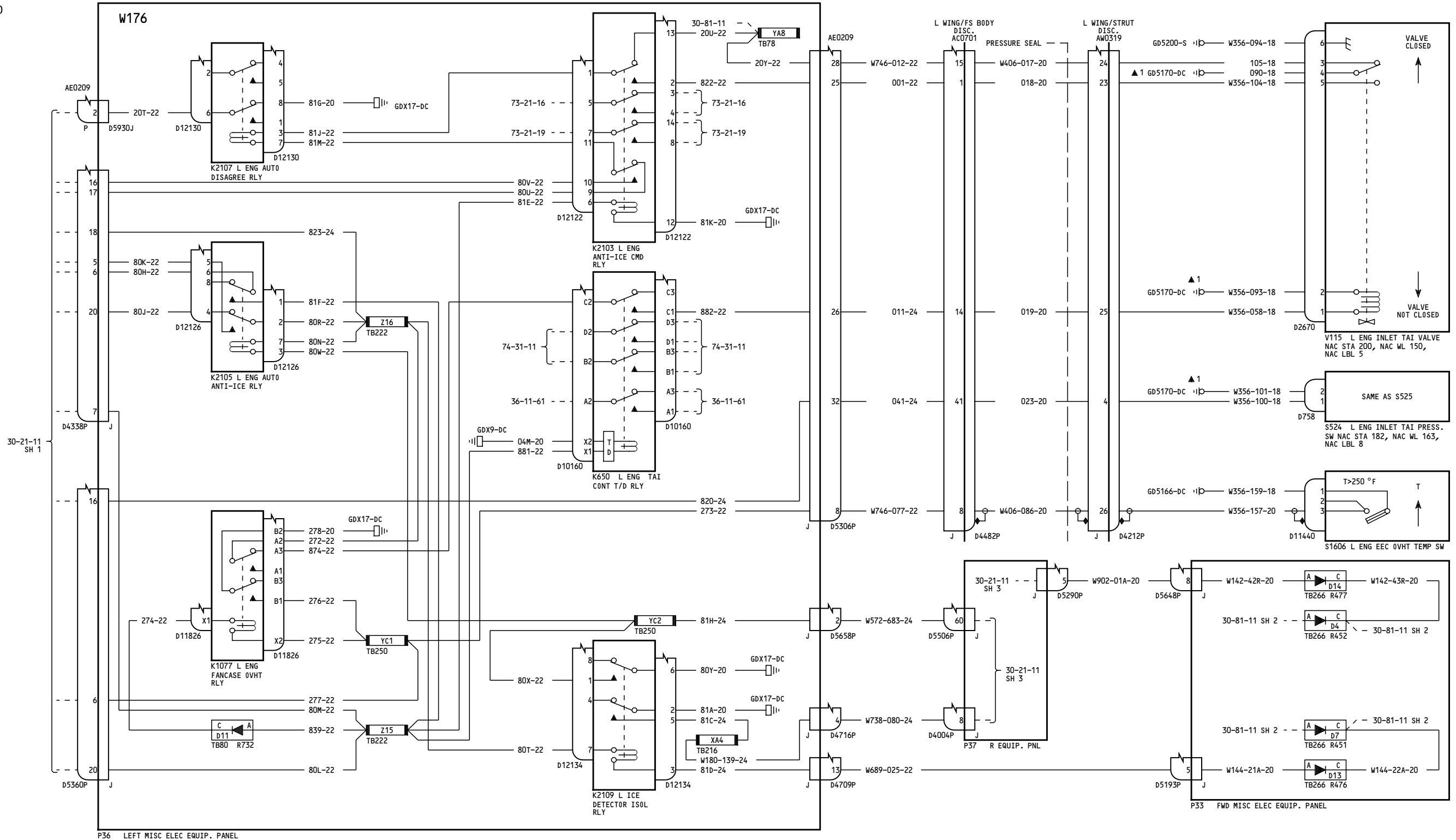

NOTE:
SHIELD PIGTAIL TO DISCONNECT BACKSHELL 2 INCHES MAXIMUM

150-154

<p>ENGINE INLET THERMAL ANTI-ICE</p> <p>D280T132</p>

<p>30-21-11</p> <p>Page 2.1 Sheet 2 Jan 21/2005</p>
--

Incorporates
30-0017

<p>30-21-11</p> <p>Page 2.1 Sheet 2 Jan 21/2005</p>
--

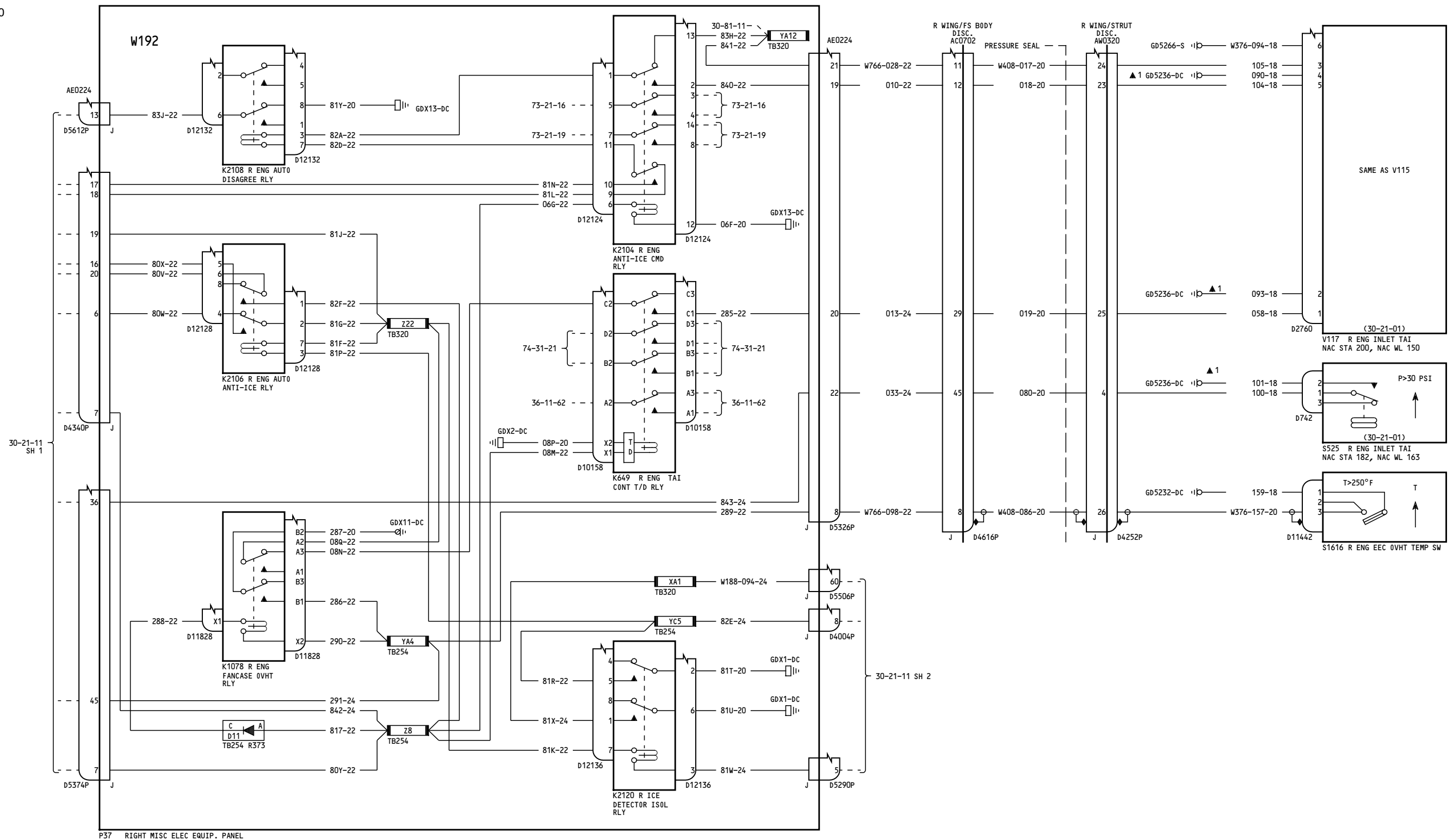

NOTE:
SHIELD PIGTAIL TO DISCONNECT BACKSHELL 2 INCH MAXIMUM

<p>150-154</p>	<p>ENGINE INLET THERMAL ANTI-ICE</p> <p>D280T132</p>
----------------	---

30-21-11

Page 2.1
Sheet 3
Jan 21/2005

Incorporates
30-0017

30-21-11

Page 2.1
Sheet 3
Jan 21/2005

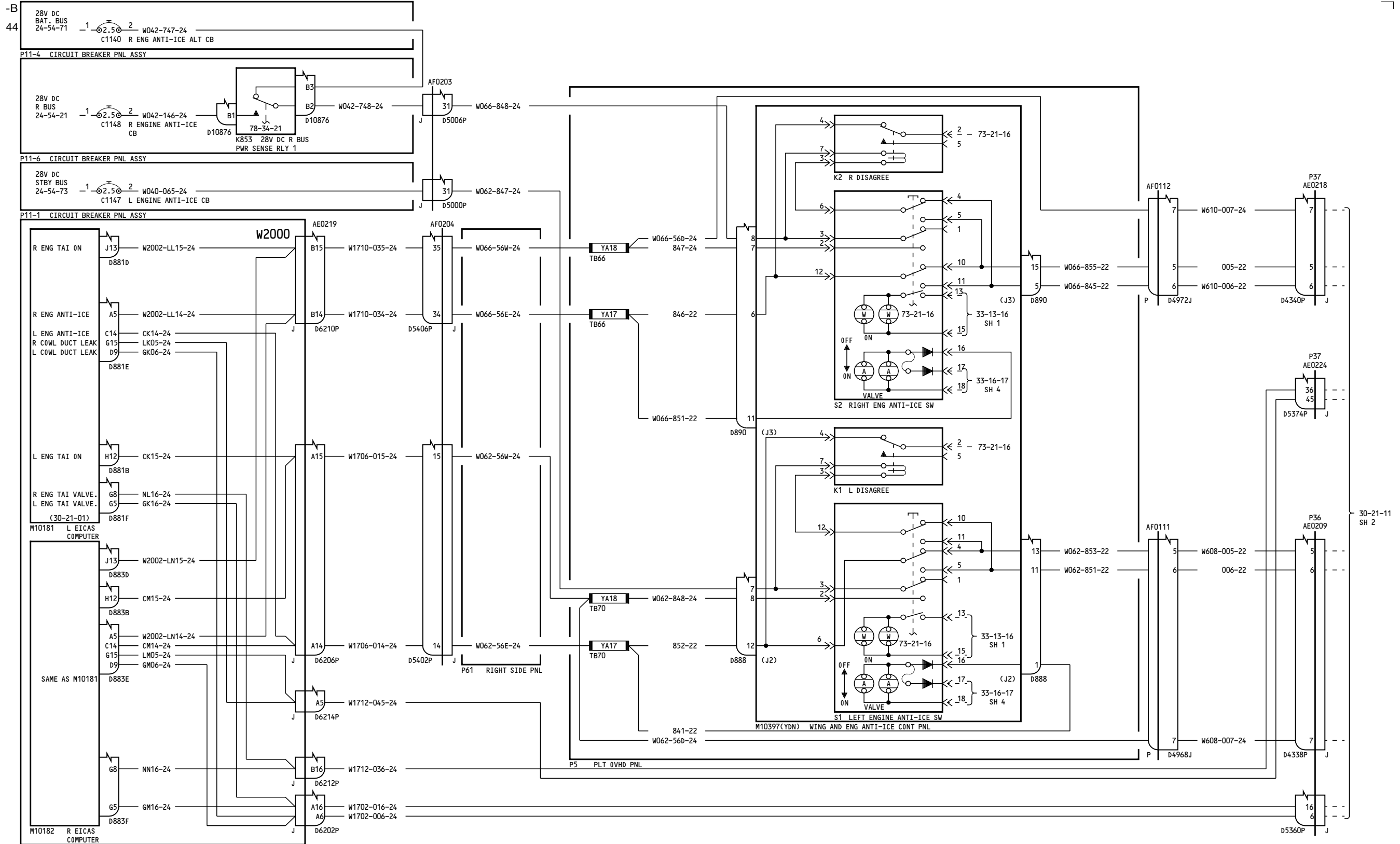

275-299
 ENGINE INLET THERMAL ANTI-ICE
 D280T132

30-21-11
 Page 3
 Sheet 1
 Jan 21/2005

30-21-11
 Page 3
 Sheet 1
 Jan 21/2005

30-21-11
 Page 3
 Sheet 1
 Jan 21/2005

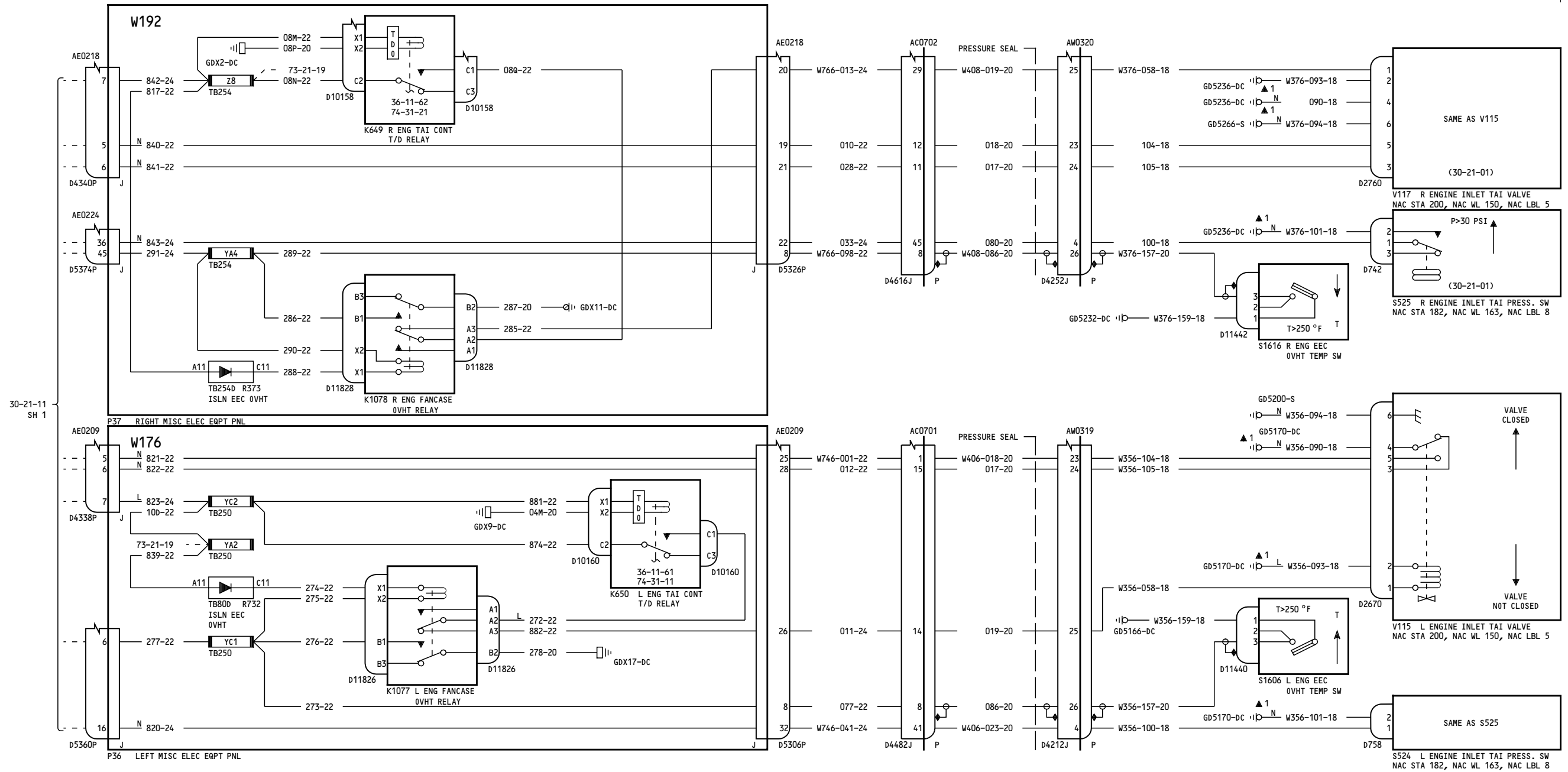

NOTES:
SHIELD PIGTAIL TO DISCONNECT
BACKSHELL 2 INCHES MAXIMUM

275-299

**ENGINE INLET THERMAL
ANTI-ICE**

D280T132

30-21-11

Page 3
Sheet 2
Jan 21/2005

30-21-11

Page 3
Sheet 2
Jan 21/2005

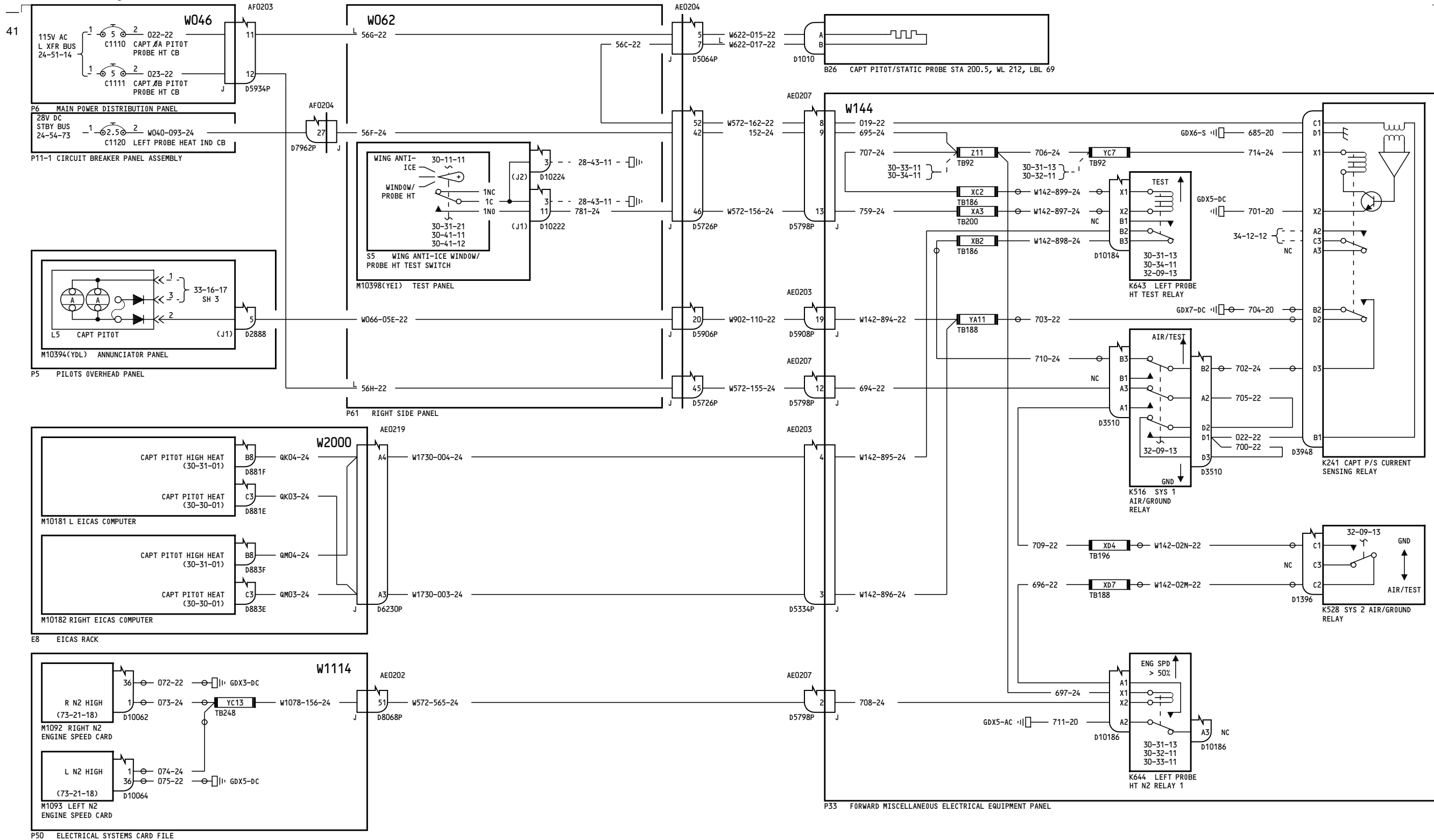

050-280

PROBE HEAT-CAPTAINS PITOT STATIC

30-31-11

Page 1.1

D280T132

Mar 09/2006

Incorporates
27A0160 R01

30-31-11

Page 1.1

Mar 09/2006

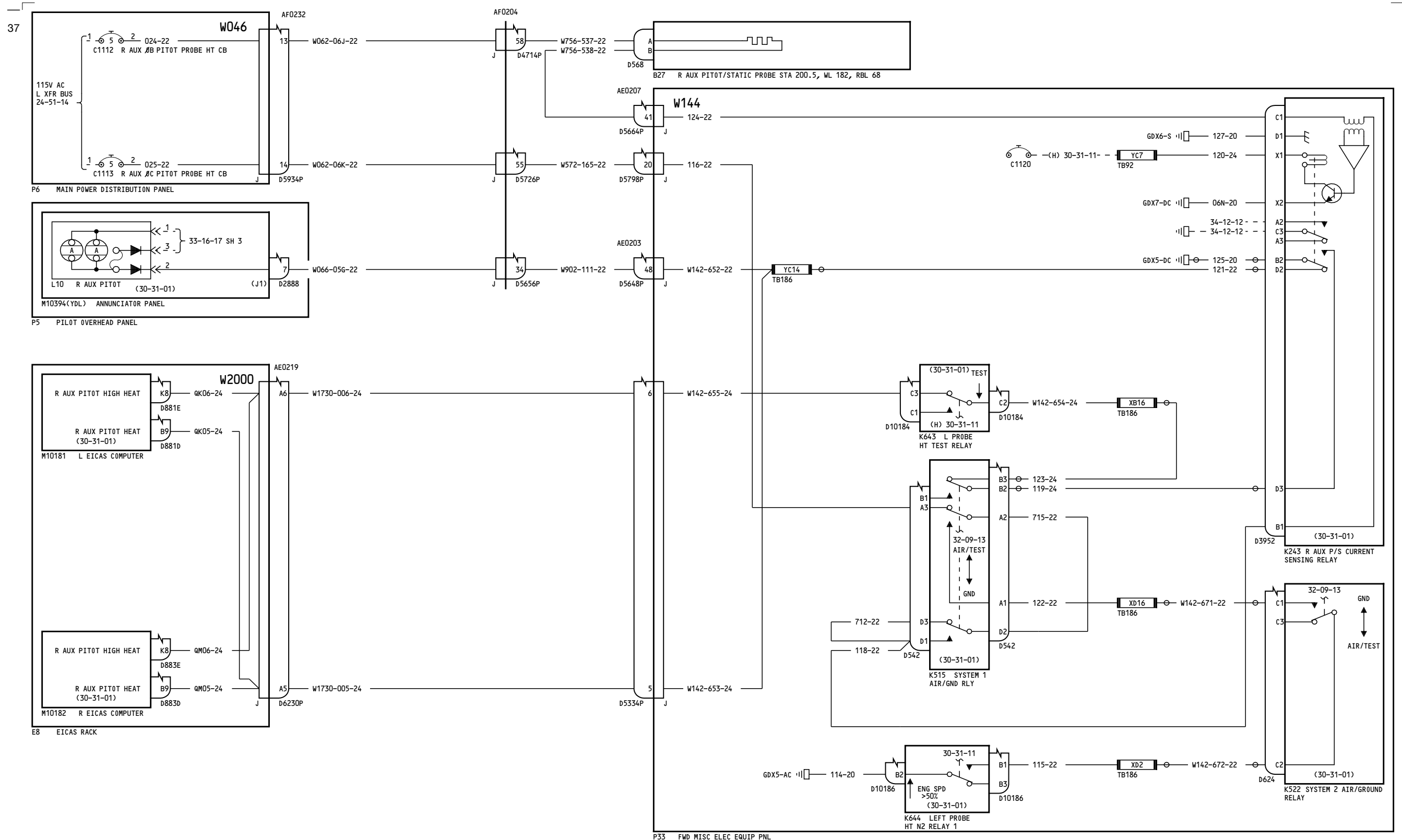

050-280

**PROBE HEAT-
RIGHT AUXILIARY PITOT
STATIC**

D280T132

30-31-13

Page 1.1

Mar 09/2006

Incorporates
27A0160 R01

30-31-13

Page 1.1

Mar 09/2006

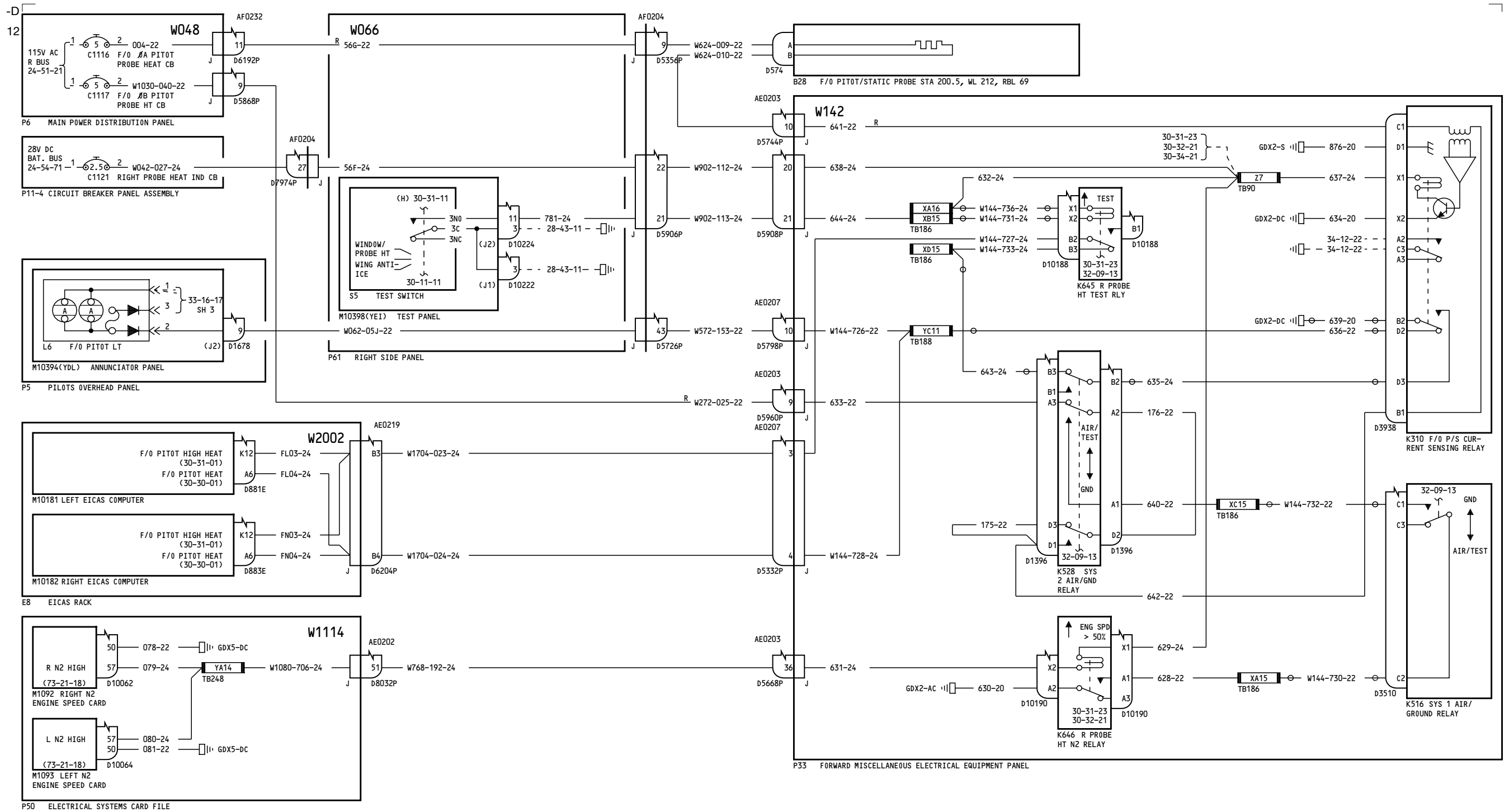

ALL

**PROBE HEAT-
FIRST OFFICER-
PITOT STATIC**

D280T132

30-31-21

Page 1

Aug 05/2009

30-31-21

Page 1

Aug 05/2009

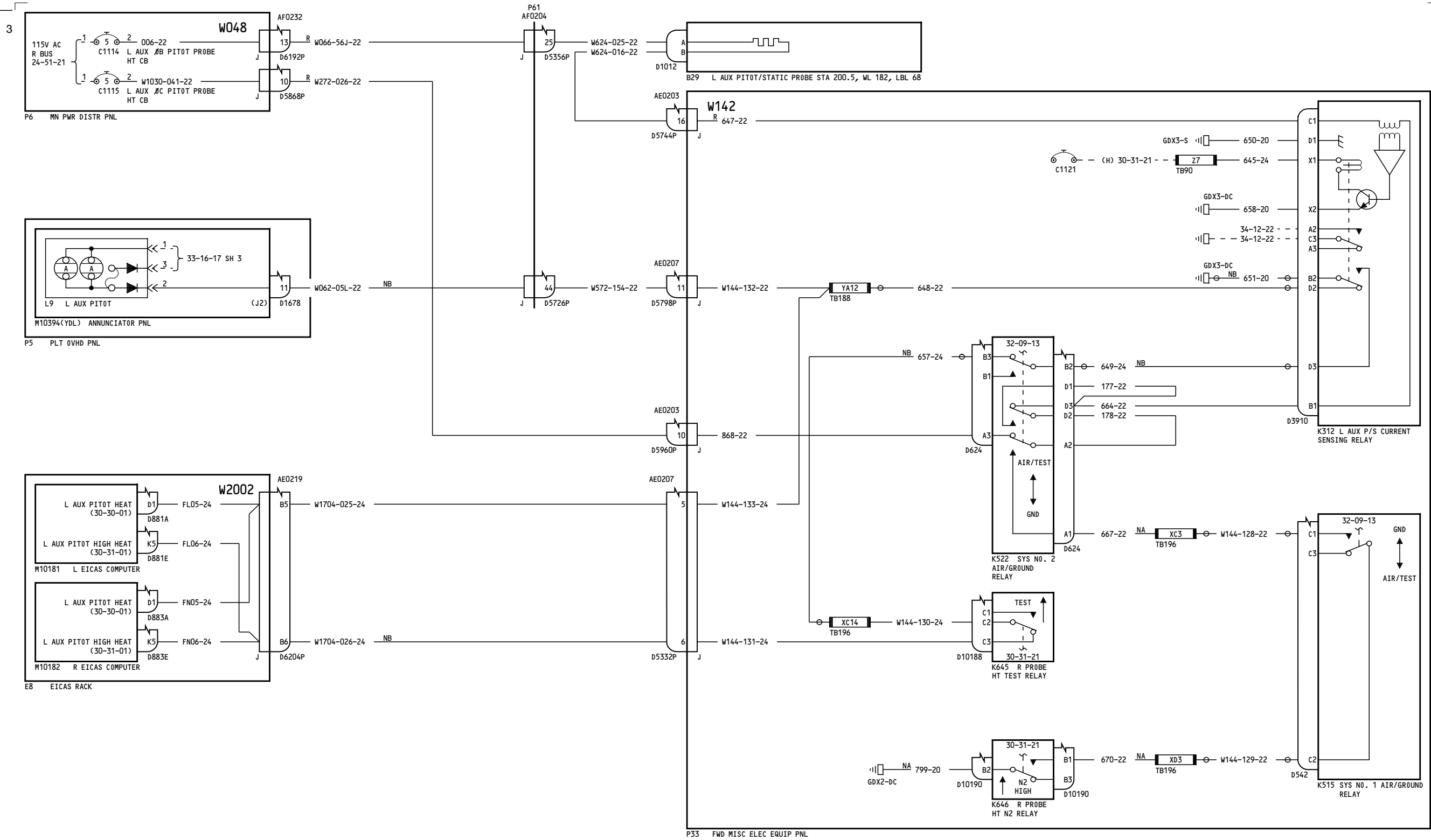

050-099

PROBE HEAT-
LEFT AUXILIARY PITOT
STATIC

30-31-23

Page 1

D280T132

Jan 21/2005

30-31-23

Page 1

Jan 21/2005

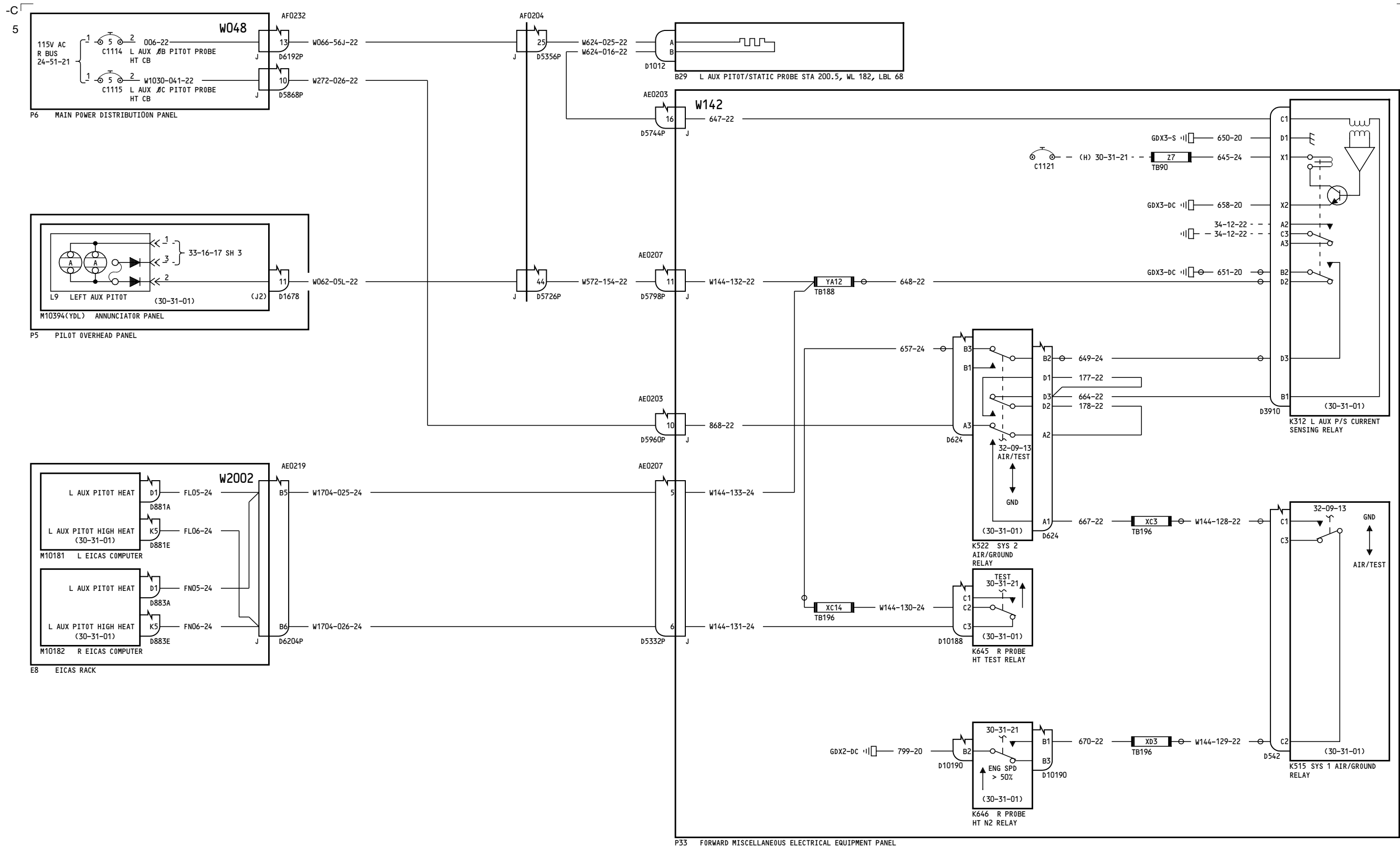

150-199, 275-299

**PROBE HEAT-
LEFT AUXILIARY PITOT
STATIC**

30-31-23

Page 2

Jan 21/2005

D280T132

30-31-23

Page 2

Jan 21/2005

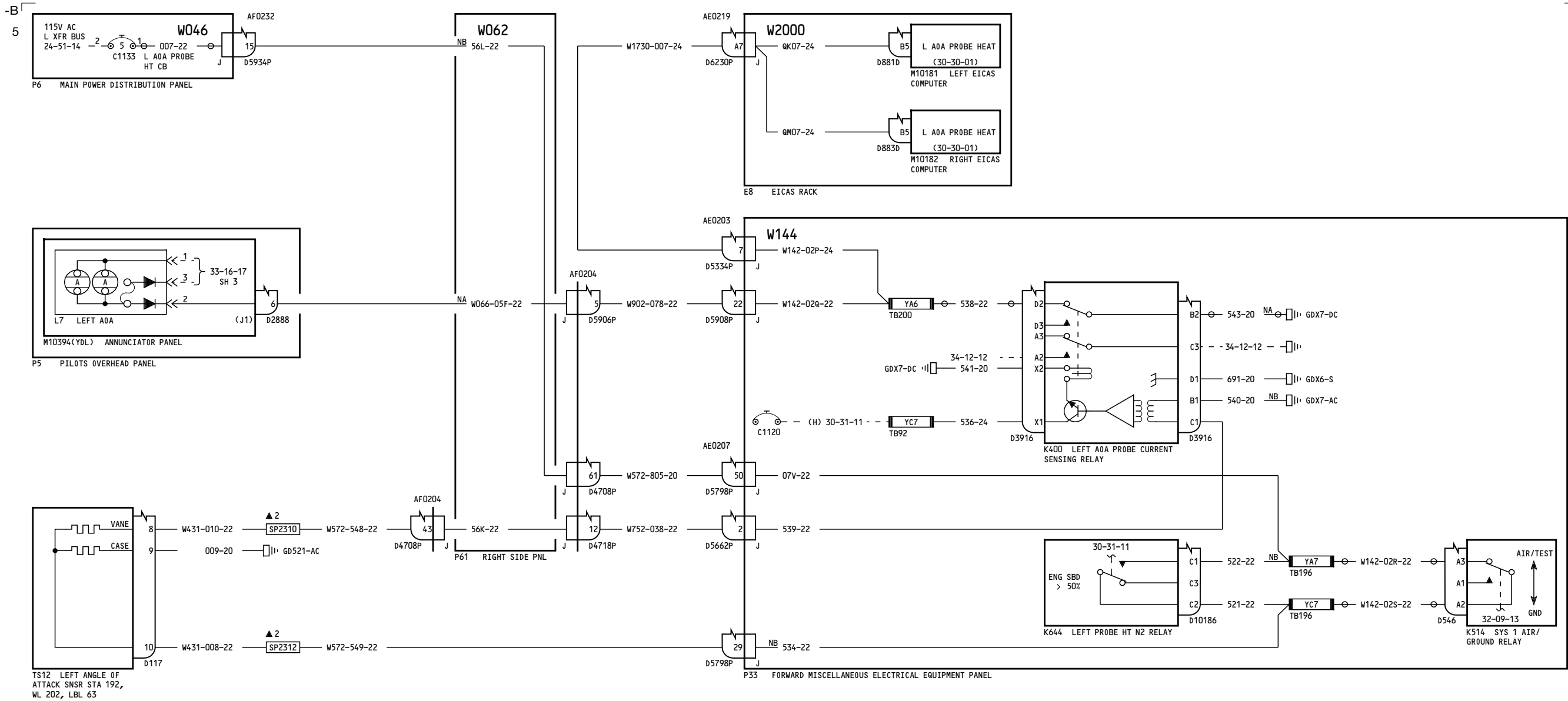

ALL	PROBE HEAT- ANGLE OF ATTACK- LEFT
	D280T132

30-32-11

Page 1

Jan 21/2005

30-32-11

Page 1

Jan 21/2005

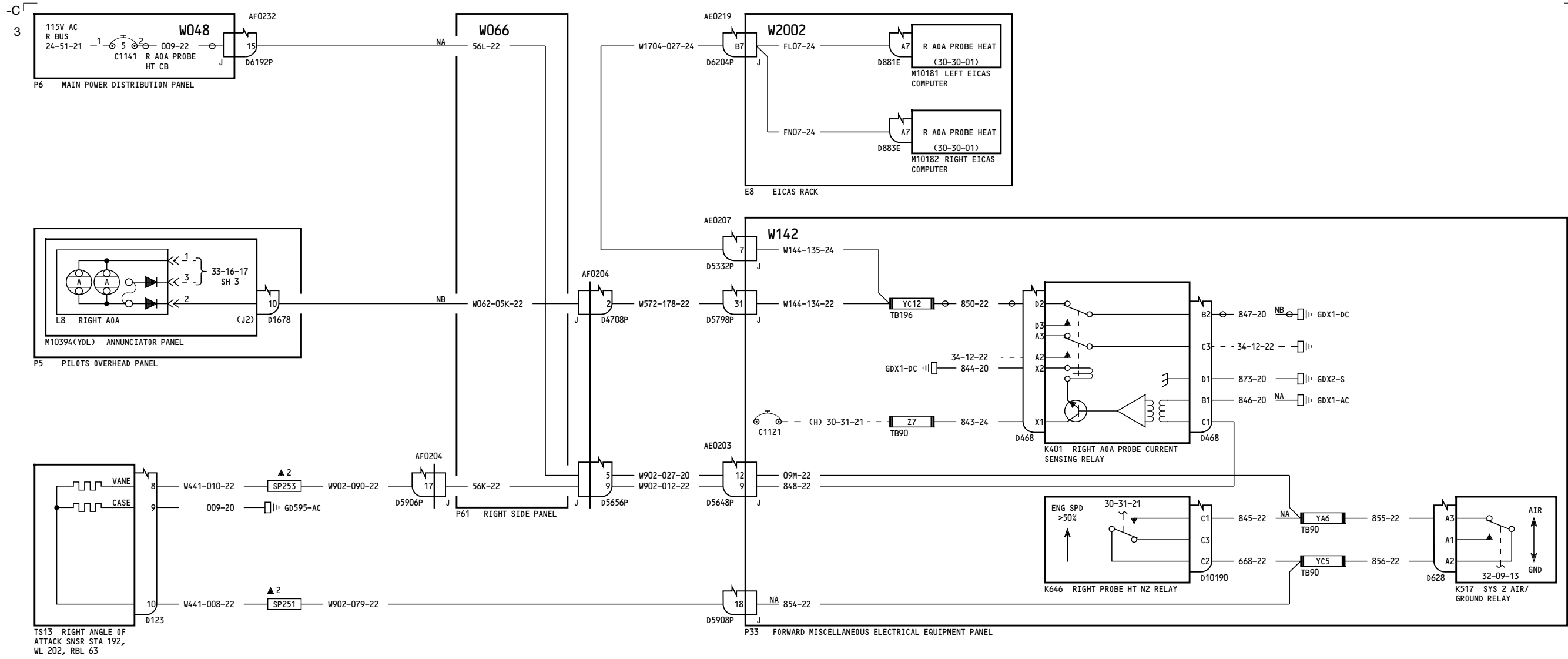

ALL

**PROBE HEAT-
ANGLE OF ATTACK-
RIGHT**

D280T132

30-32-21

Page 1

Jan 21/2005

30-32-21

Page 1

Jan 21/2005

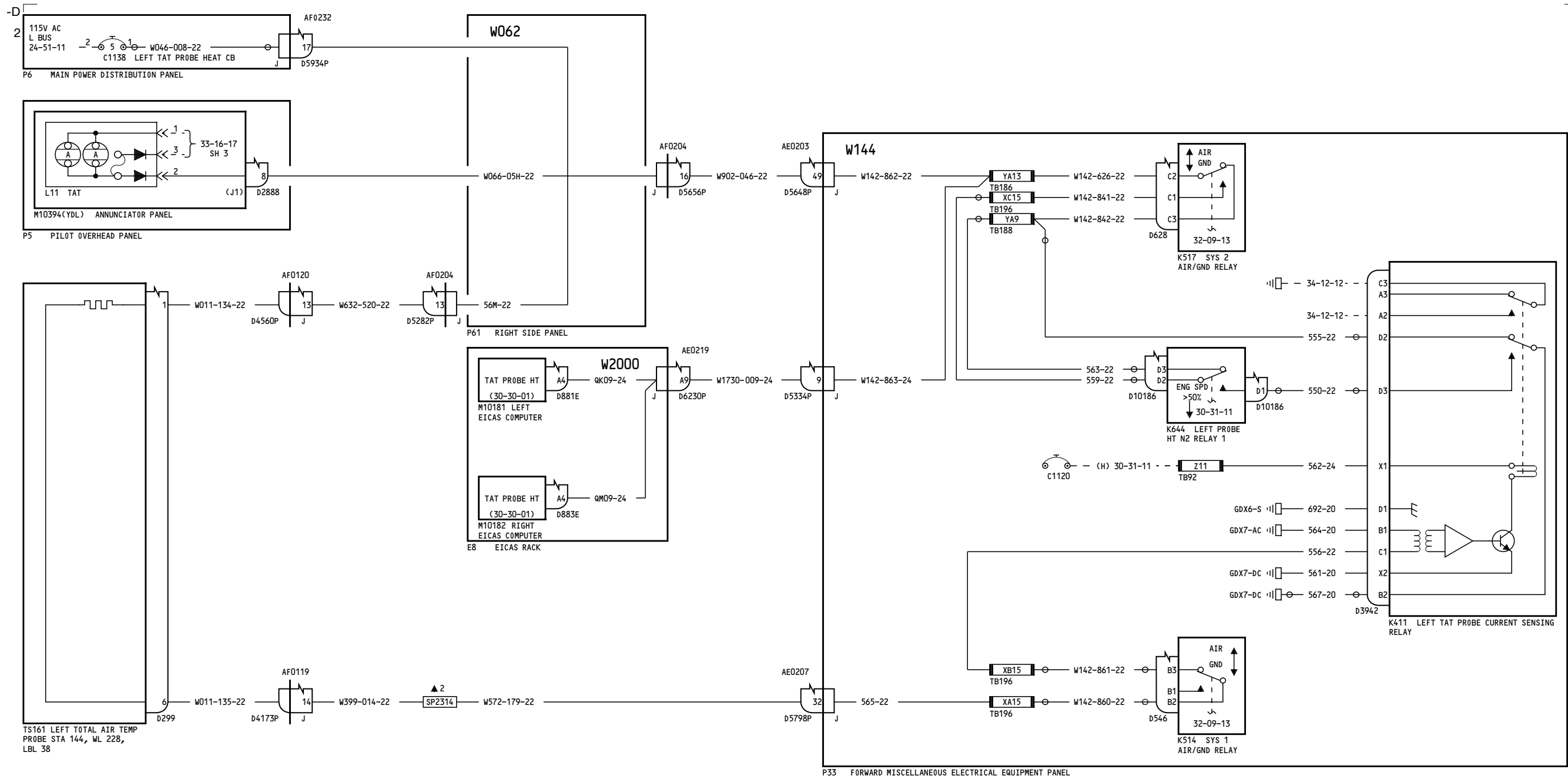

ALL

**PROBE HEAT-
TOTAL AIR TEMPERATURE-
LEFT**

D280T132

30-33-11

Page 1

Jan 21/2005

30-33-11

Page 1

Jan 21/2005

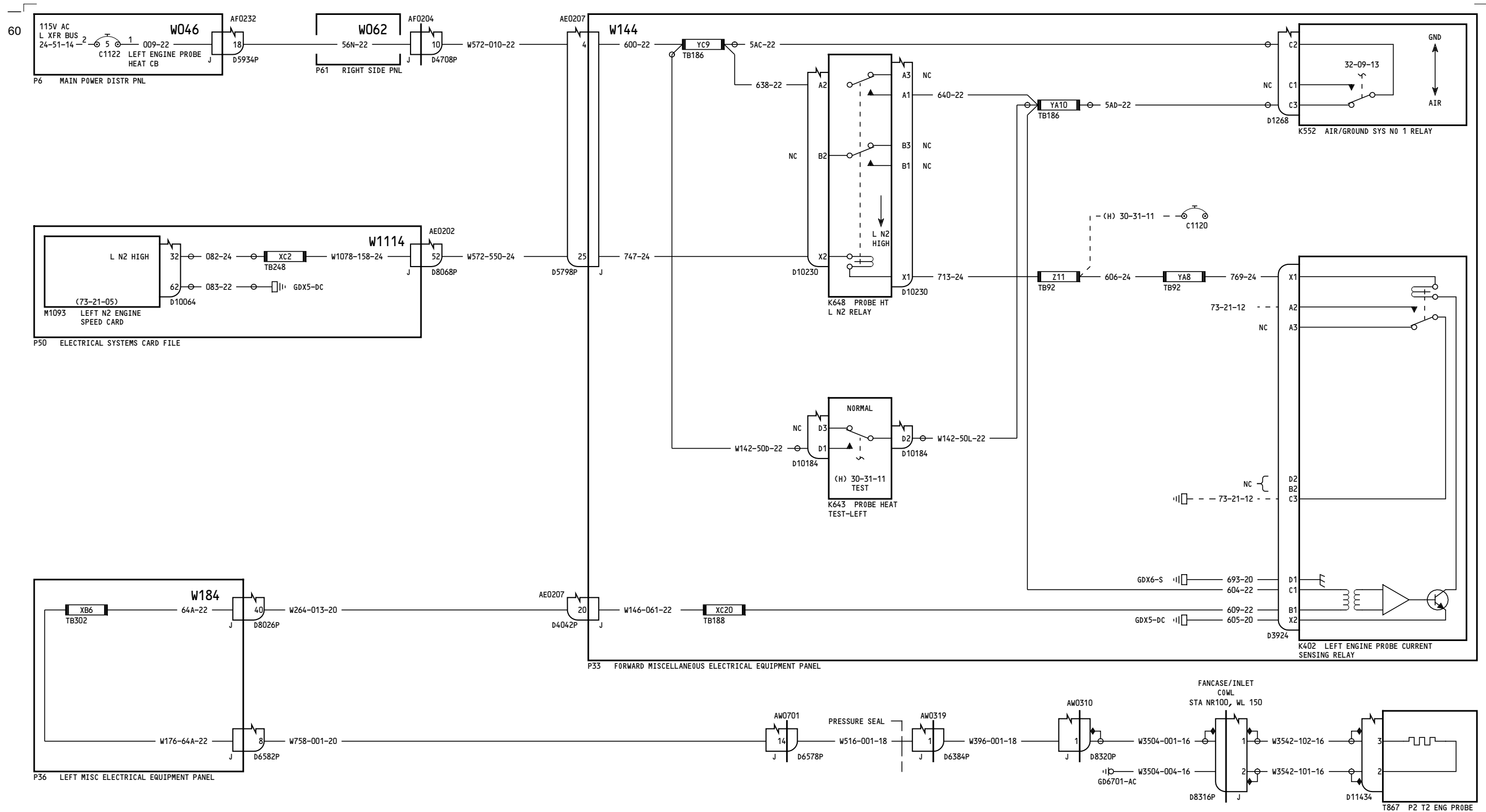

NOTES:
SHIELD PIGTAIL TO DISCONNECT BACKSHELL 2 INCH MAXIMUM

050, 150, 152-280

**PROBE HEAT-
ENGINE TT2-
LEFT**

D280T132

30-34-11

Page 1.1

Mar 09/2006

Incorporates
27A0160
27A0160 R01

30-34-11

Page 1.1

Mar 09/2006

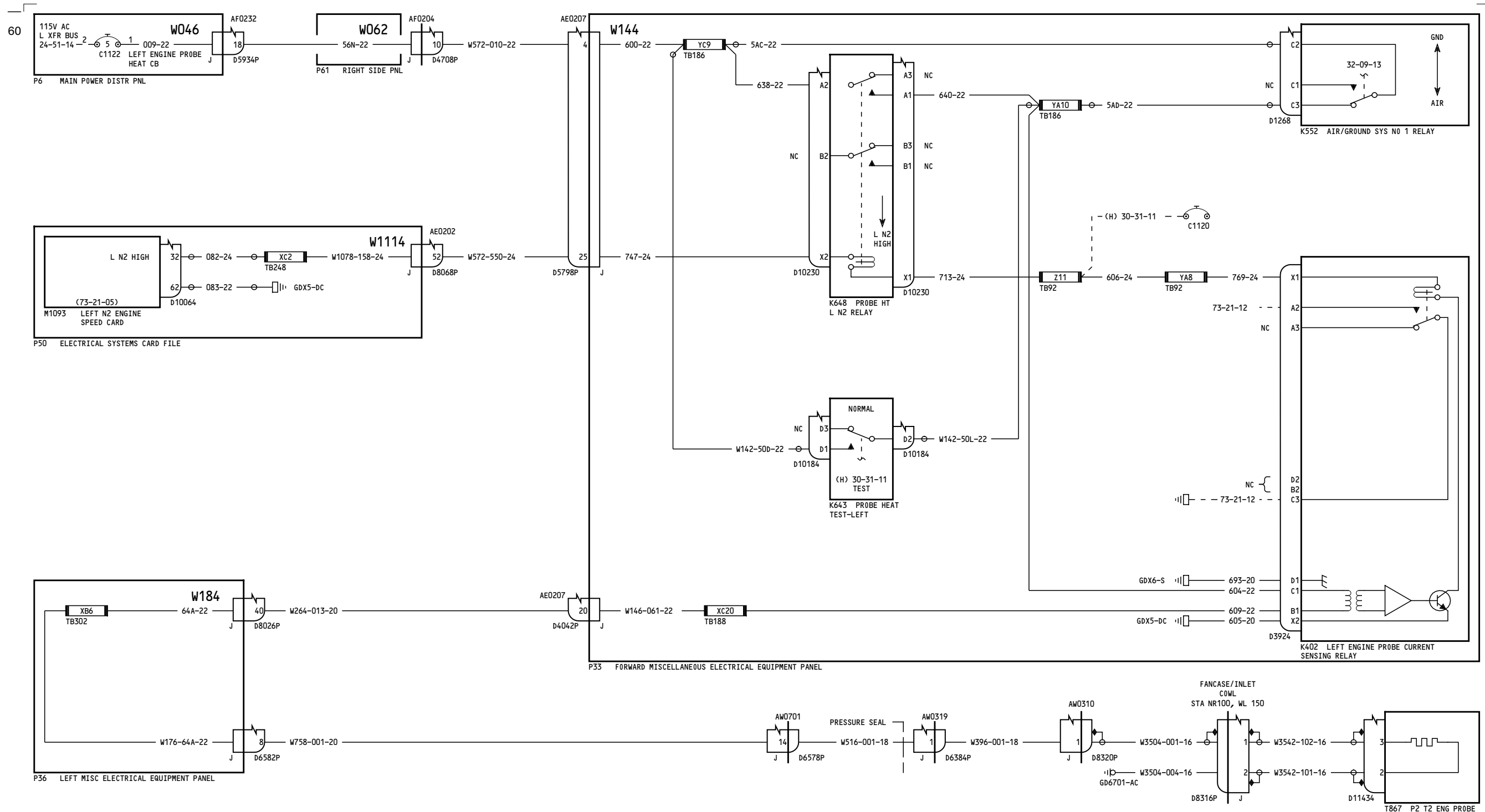

NOTES:
SHIELD PIGTAIL TO DISCONNECT BACKSHELL 2 INCH MAXIMUM

051, 151

**PROBE HEAT-
ENGINE TT2-
LEFT**

D280T132

30-34-11

Page 2.1

Mar 09/2006

Incorporates
27A0160 R01

30-34-11

Page 2.1

Mar 09/2006

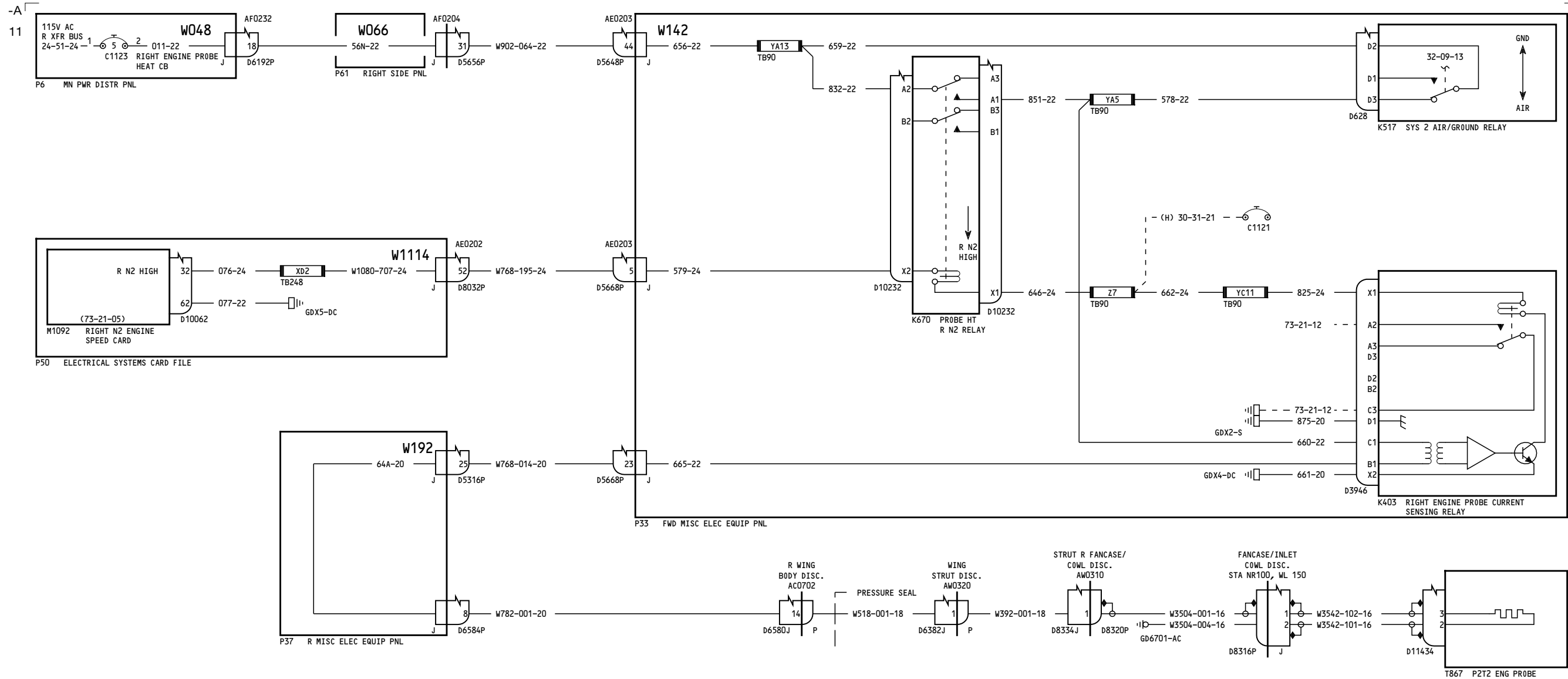

NOTES:
SHIELD PIGTAIL TO DISCONNECT BACK SHELL 2 INCH MAXIMUM

050-099, 150-199	PROBE HEAT- ENGINE TT2- RIGHT
	D280T132

30-34-21

Page 1

Jan 21/2005

30-34-21

Page 1

Jan 21/2005

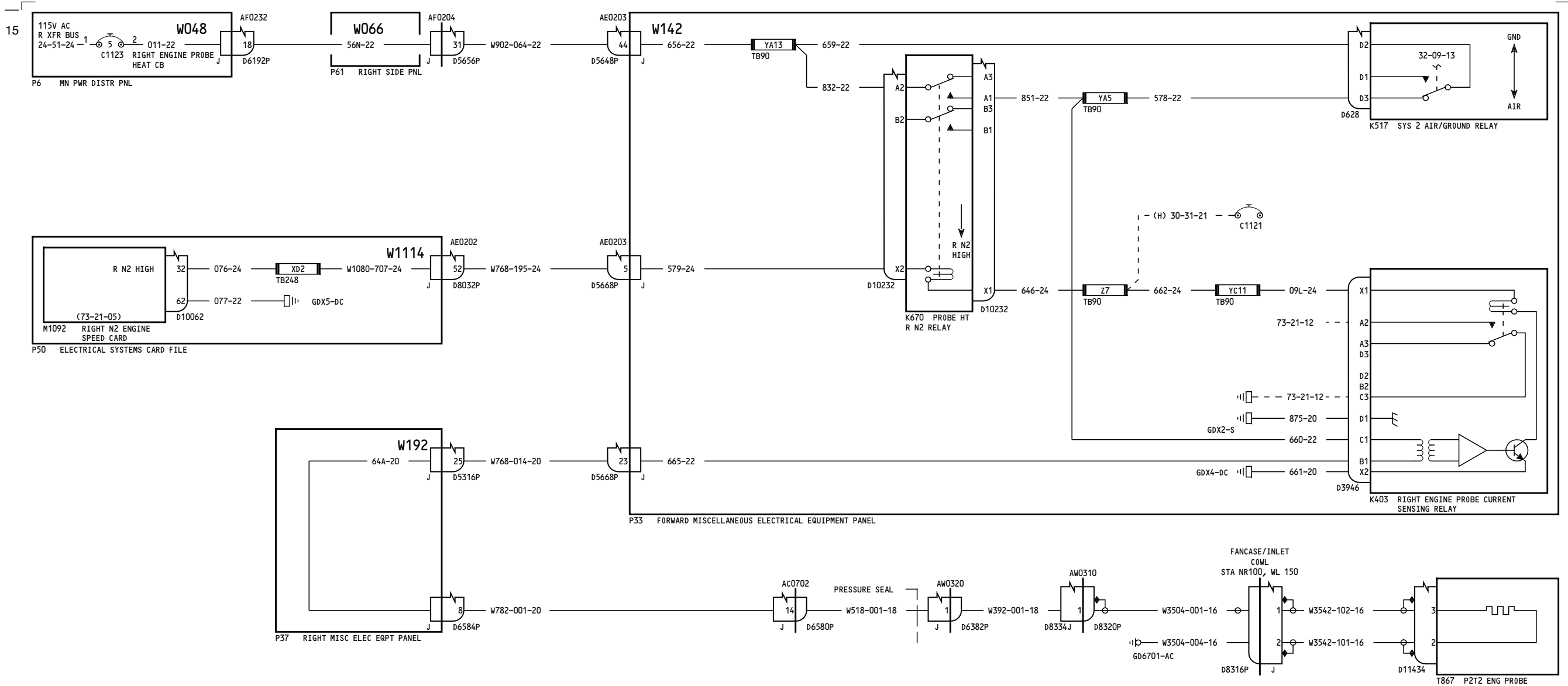

NOTES:
SHIELD PIGTAIL TO DISCONNECT BACK SHELL 2 INCH MAXIMUM

275-299	<p>PROBE HEAT-ENGINE TT2-RIGHT</p> <p>D280T132</p>
---------	---

30-34-21
Page 2
Jan 21/2005

30-34-21
Page 2
Jan 21/2005

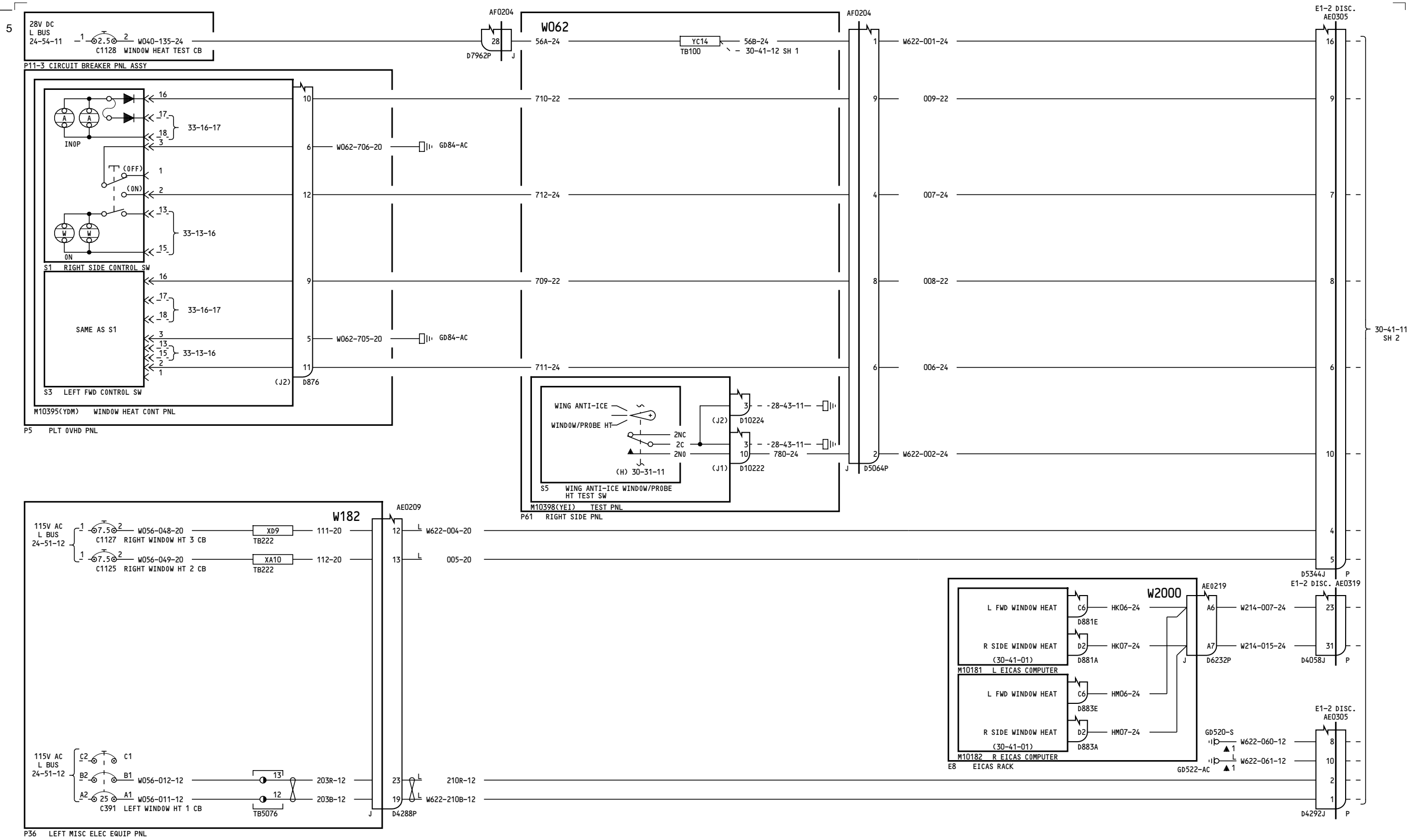

050-099

**WINDOW HEAT-
LEFT FORWARD &
RIGHT SIDE**

D280T132

30-41-11

Page 1
Sheet 1
Jan 21/2005

30-41-11

Page 1
Sheet 1
Jan 21/2005

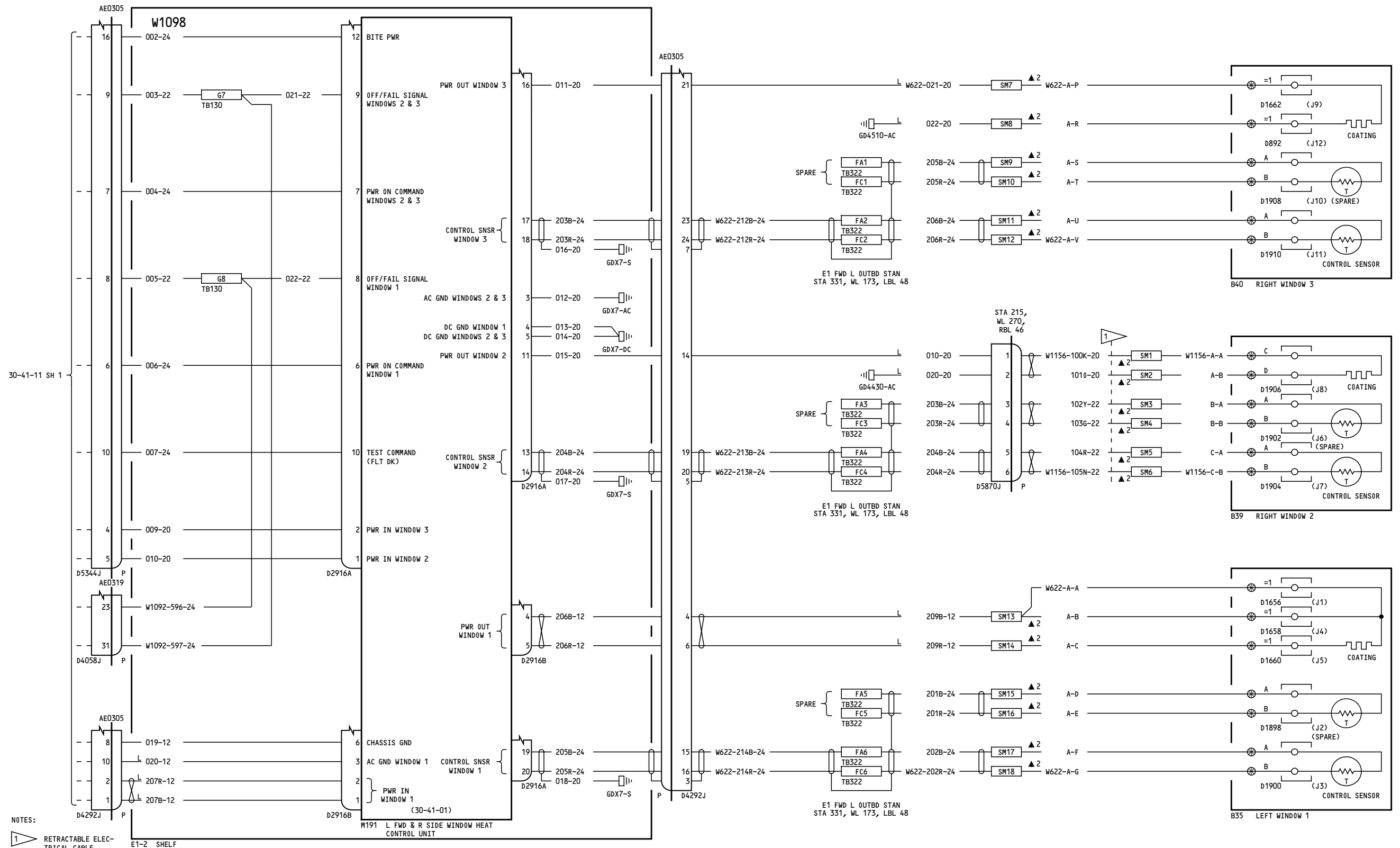

050-099

WINDOW HEAT-
LEFT FORWARD &
RIGHT SIDE

30-41-11

Page 1
Sheet 2
Jan 21/2005

D280T132

30-41-11

Page 1
Sheet 2
Jan 21/2005

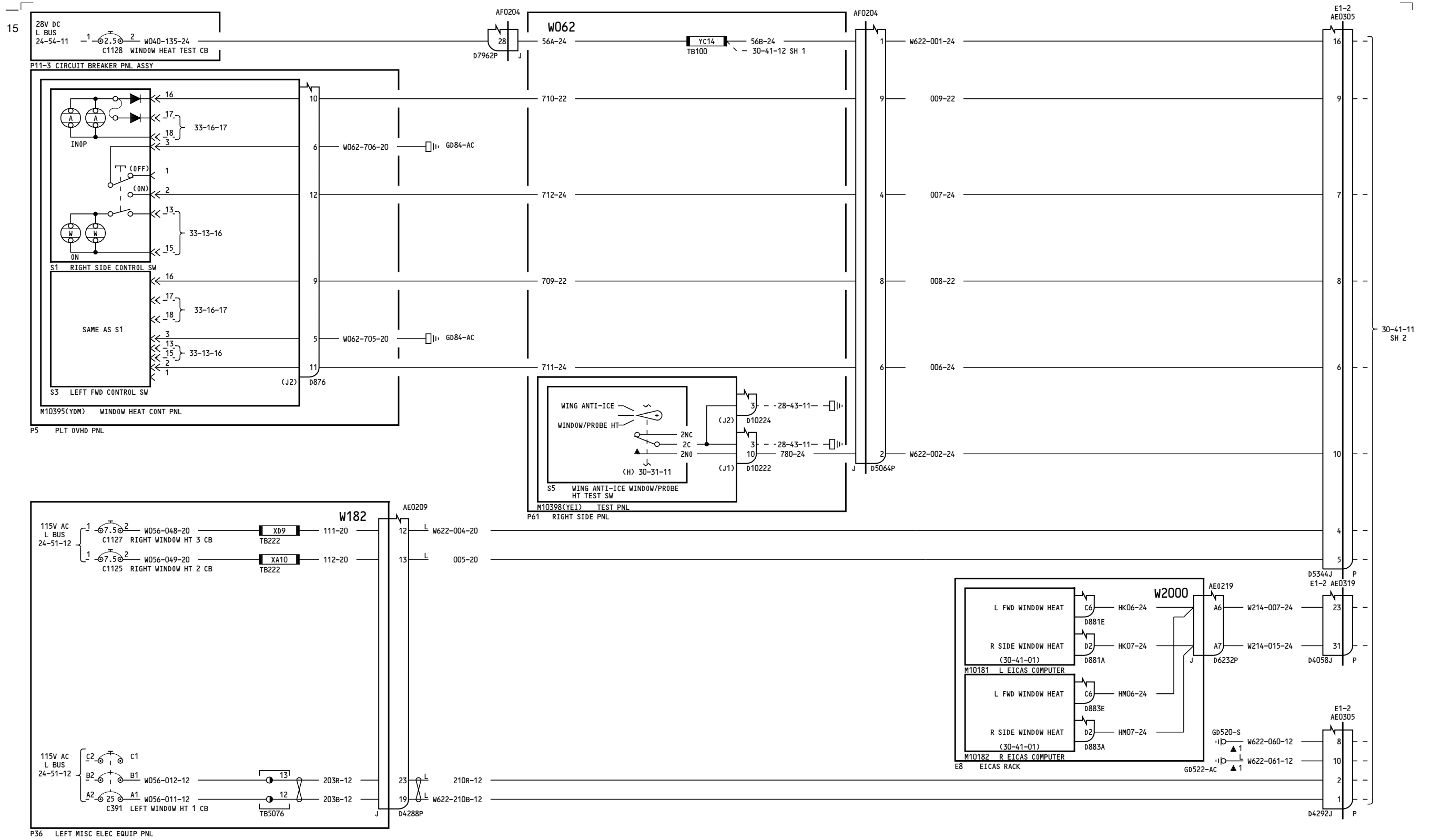

150-154, 275-276

**WINDOW HEAT-
LEFT FORWARD &
RIGHT SIDE**

30-41-11

Page 2.1
Sheet 1
Jan 21/2005

D280T132

30-41-11

Page 2.1
Sheet 1
Jan 21/2005

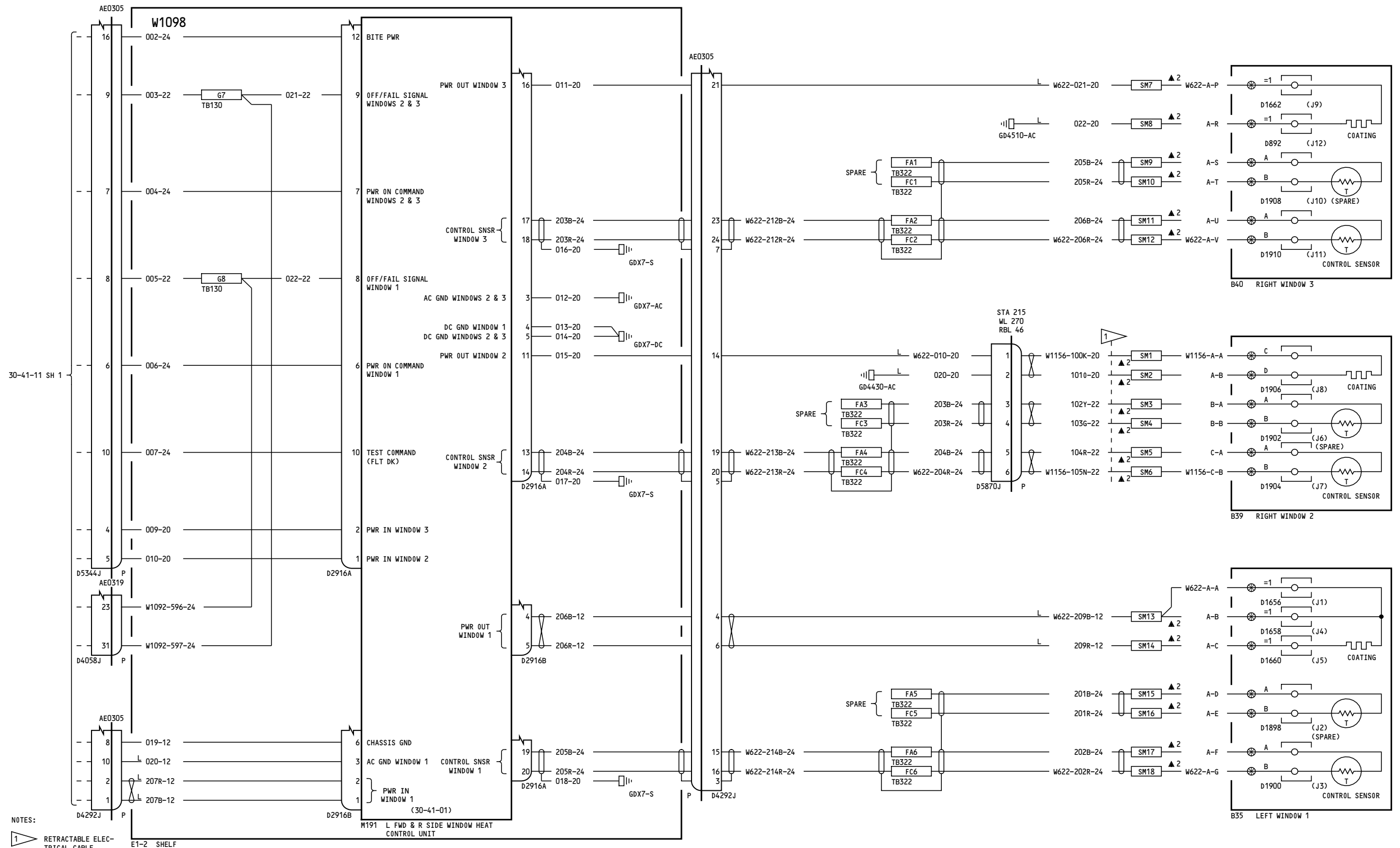

150-154, 275-276

**WINDOW HEAT-
LEFT FORWARD &
RIGHT SIDE**

30-41-11

Page 2.1
Sheet 2
Jan 21/2005

D280T132

Incorporates
30-0015

30-41-11

Page 2.1
Sheet 2
Jan 21/2005

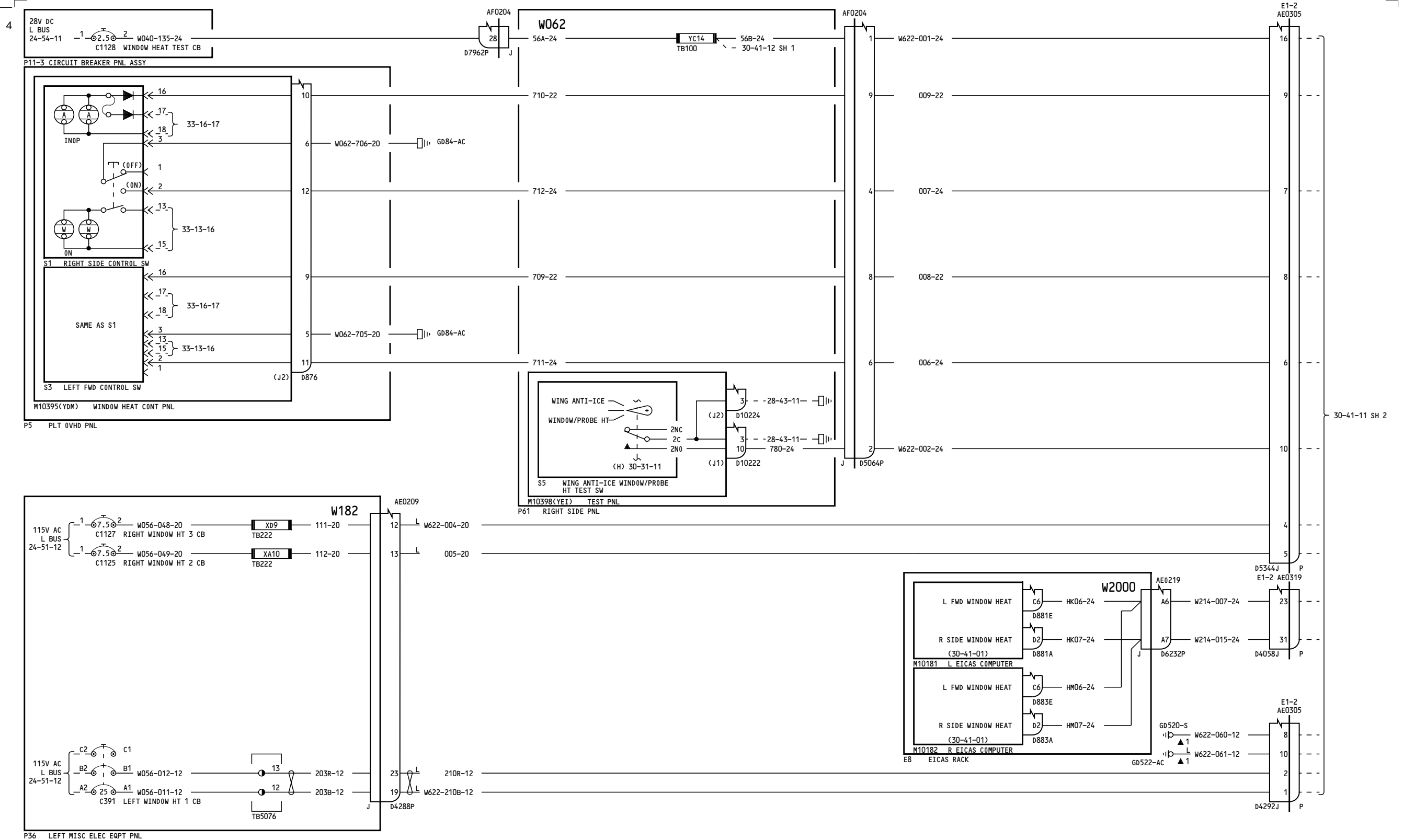

155-199, 277-299

**WINDOW HEAT-
LEFT FORWARD &
RIGHT SIDE**

30-41-11

Page 3
Sheet 1
Jan 21/2005

D280T132

30-41-11

Page 3
Sheet 1
Jan 21/2005

-B
4

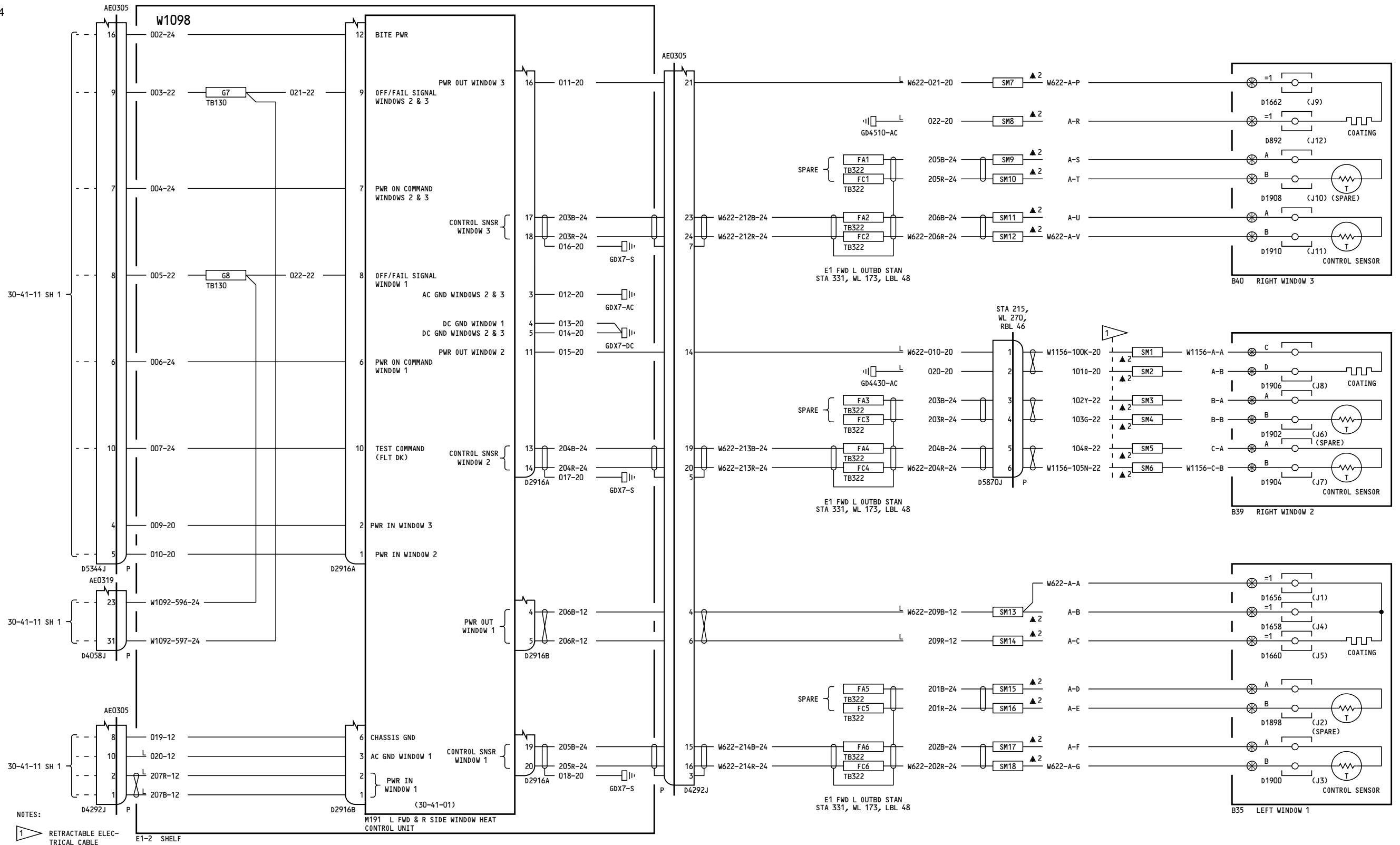

155-199, 277-299

**WINDOW HEAT-
LEFT FORWARD &
RIGHT SIDE**

D280T132

30-41-11

Page 3
Sheet 2
Jan 21/2005

30-41-11

Page 3
Sheet 2
Jan 21/2005

17

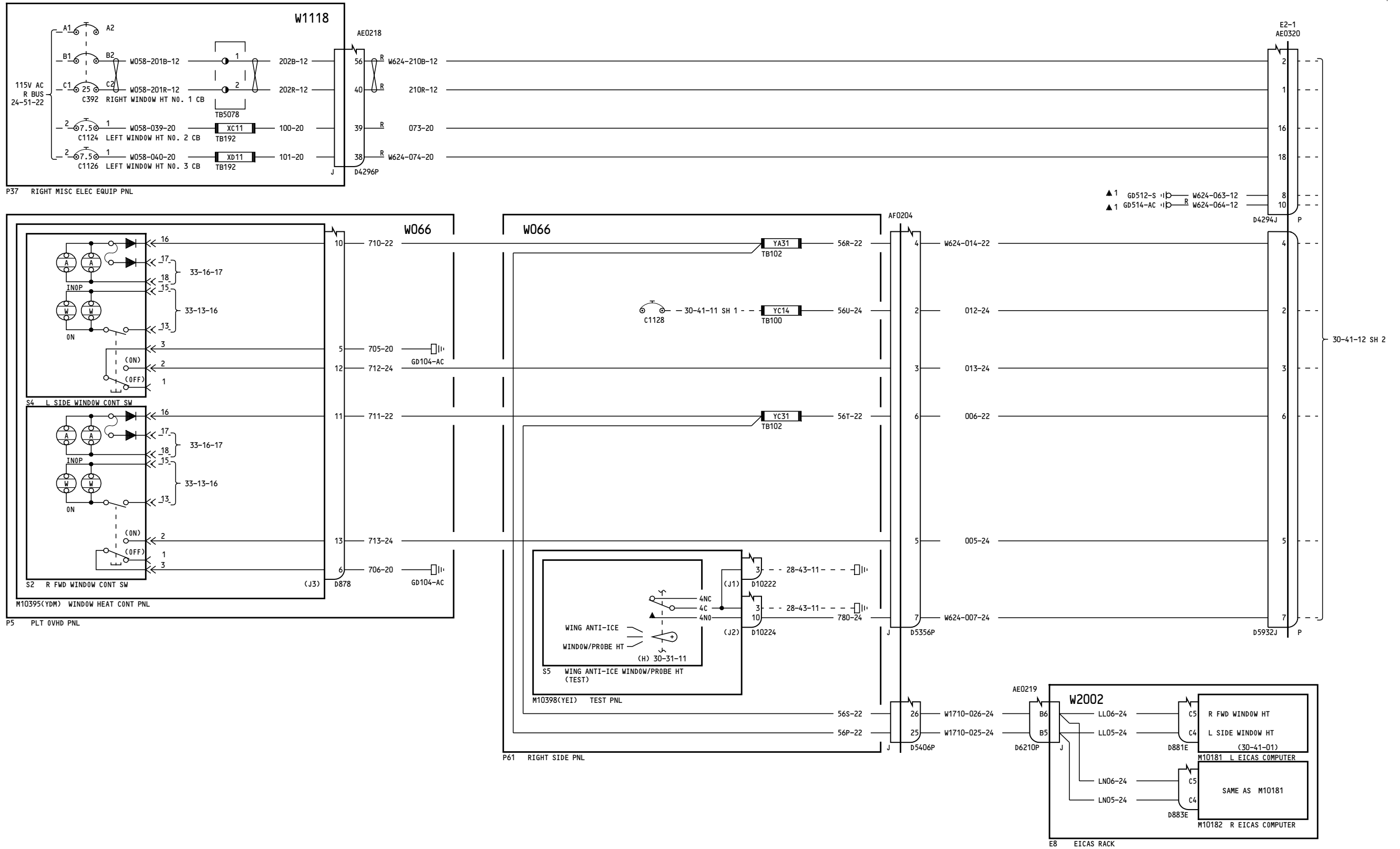

050-099

WINDOW HEAT-
RIGHT FORWARD &
LEFT SIDE

30-41-12

Page 1
Sheet 1
Jan 21/2005

D280T132

30-41-12

Page 1
Sheet 1
Jan 21/2005

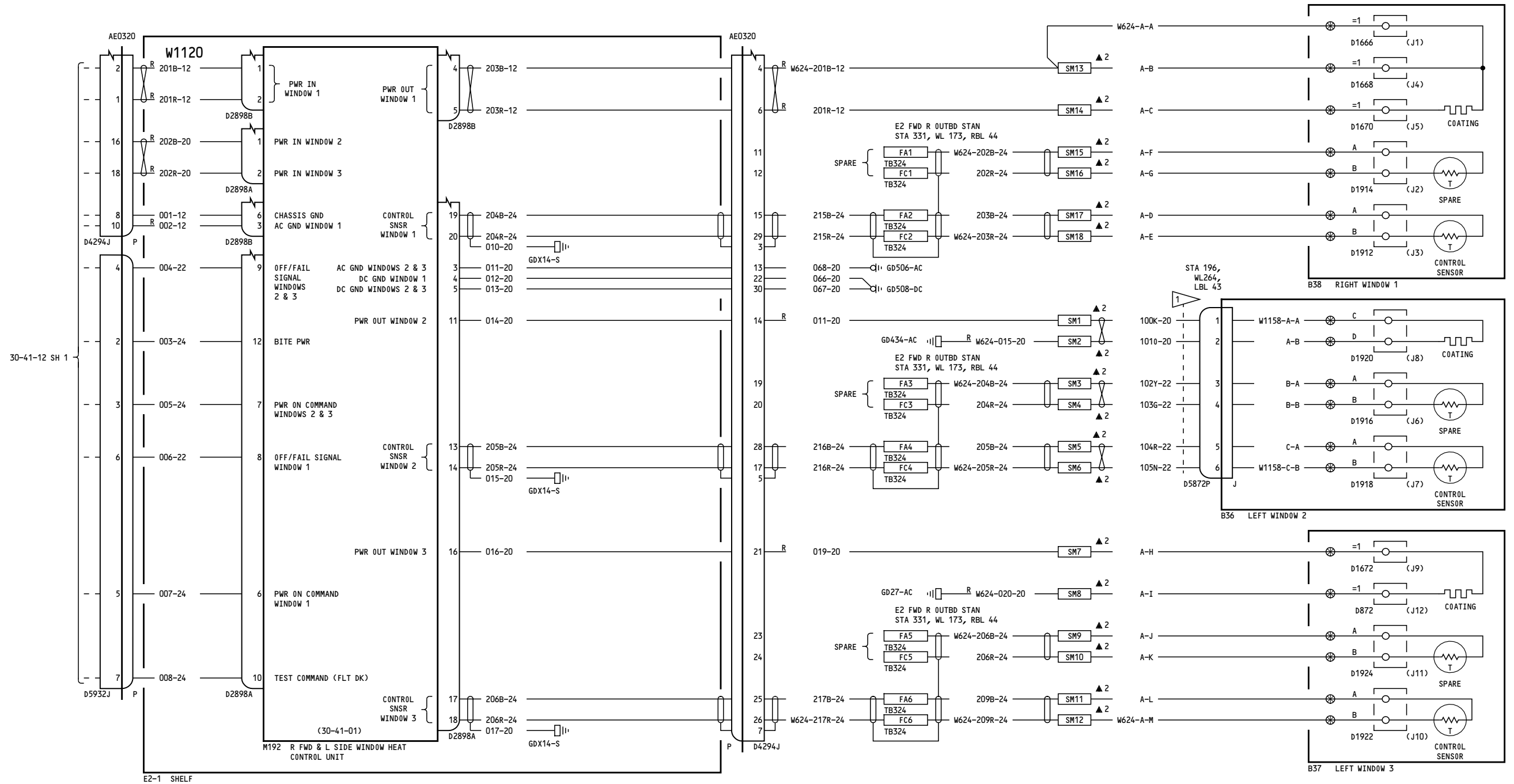

NOTES:
 1 ▷ RETRACTABLE ELECTRICAL CABLE.

050-099

**WINDOW HEAT-
RIGHT FORWARD &
LEFT SIDE**

30-41-12

Page 1
Sheet 2
Jan 21/2005

D280T132

30-41-12

Page 1
Sheet 2
Jan 21/2005

24

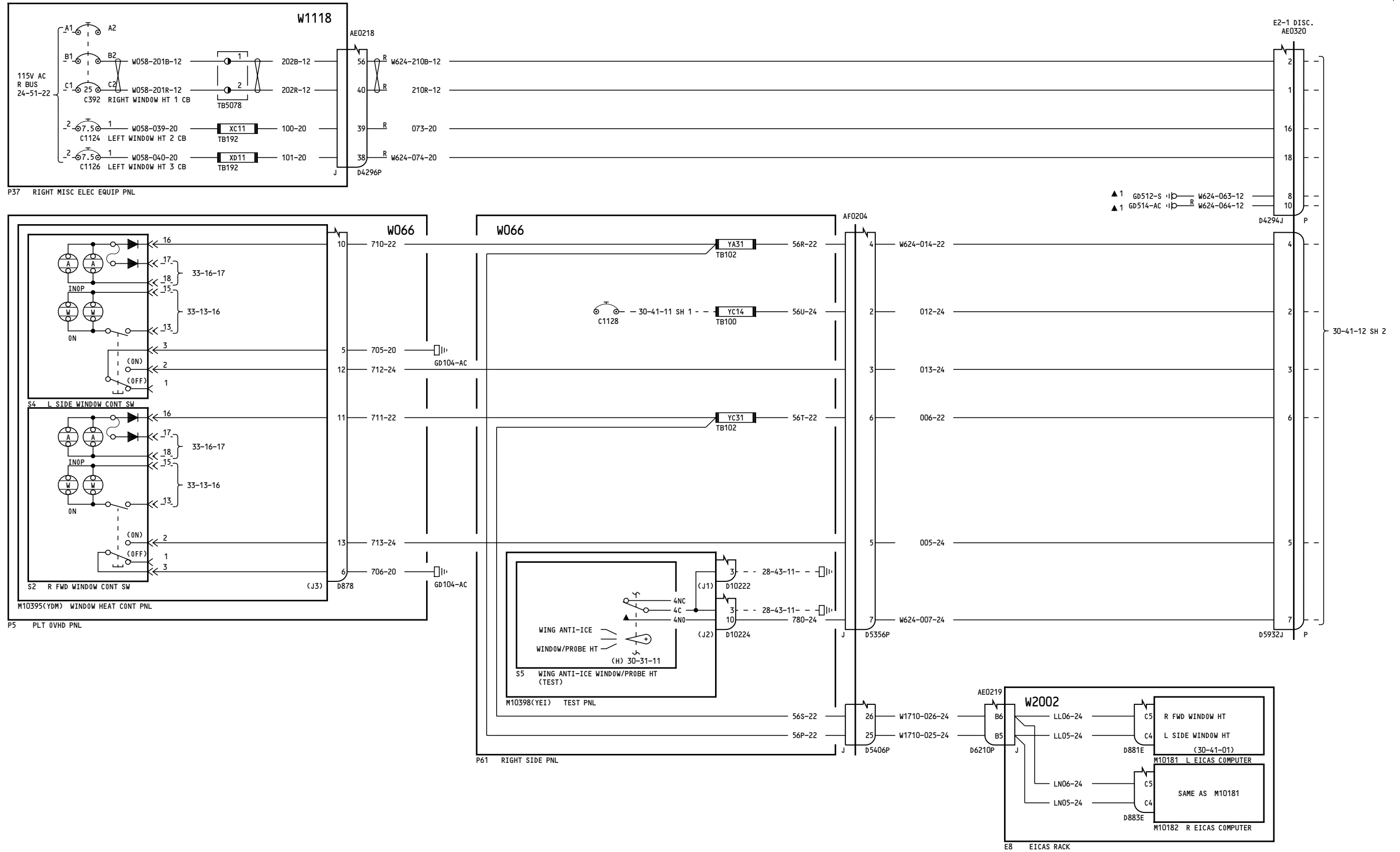

150-154, 275-276

**WINDOW HEAT-
RIGHT FORWARD &
LEFT SIDE**

30-41-12

Page 2.1
Sheet 1
Jan 21/2005

D280T132

30-41-12

Page 2.1
Sheet 1
Jan 21/2005

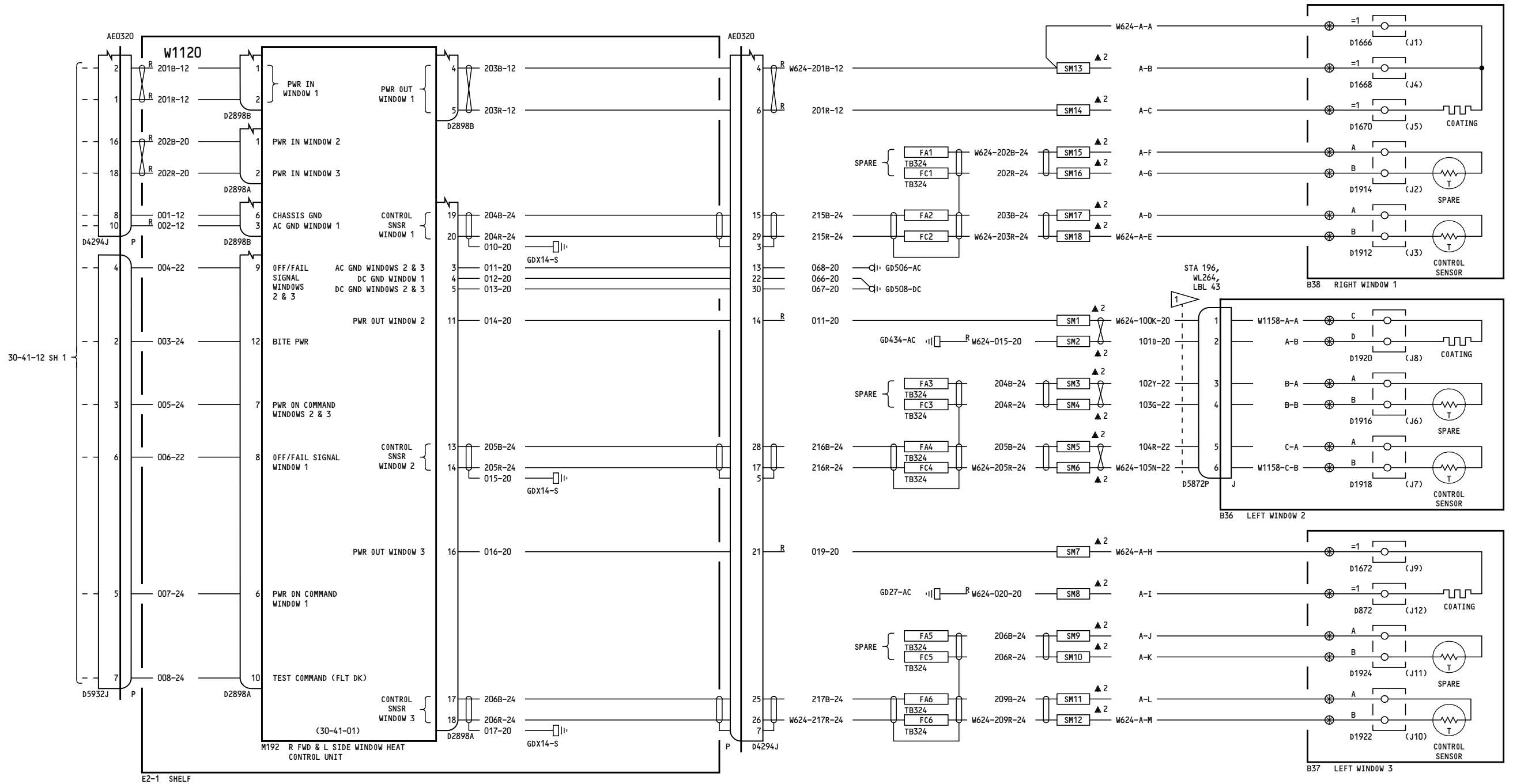

NOTES:
 1 RETRACTABLE ELECTRICAL CABLE.

150-154, 275-276

**WINDOW HEAT-
 RIGHT FORWARD &
 LEFT SIDE**

D280T132

30-41-12

Page 2.1
 Sheet 2
 Jan 21/2005

Incorporates
 30-0015

30-41-12

Page 2.1
 Sheet 2
 Jan 21/2005

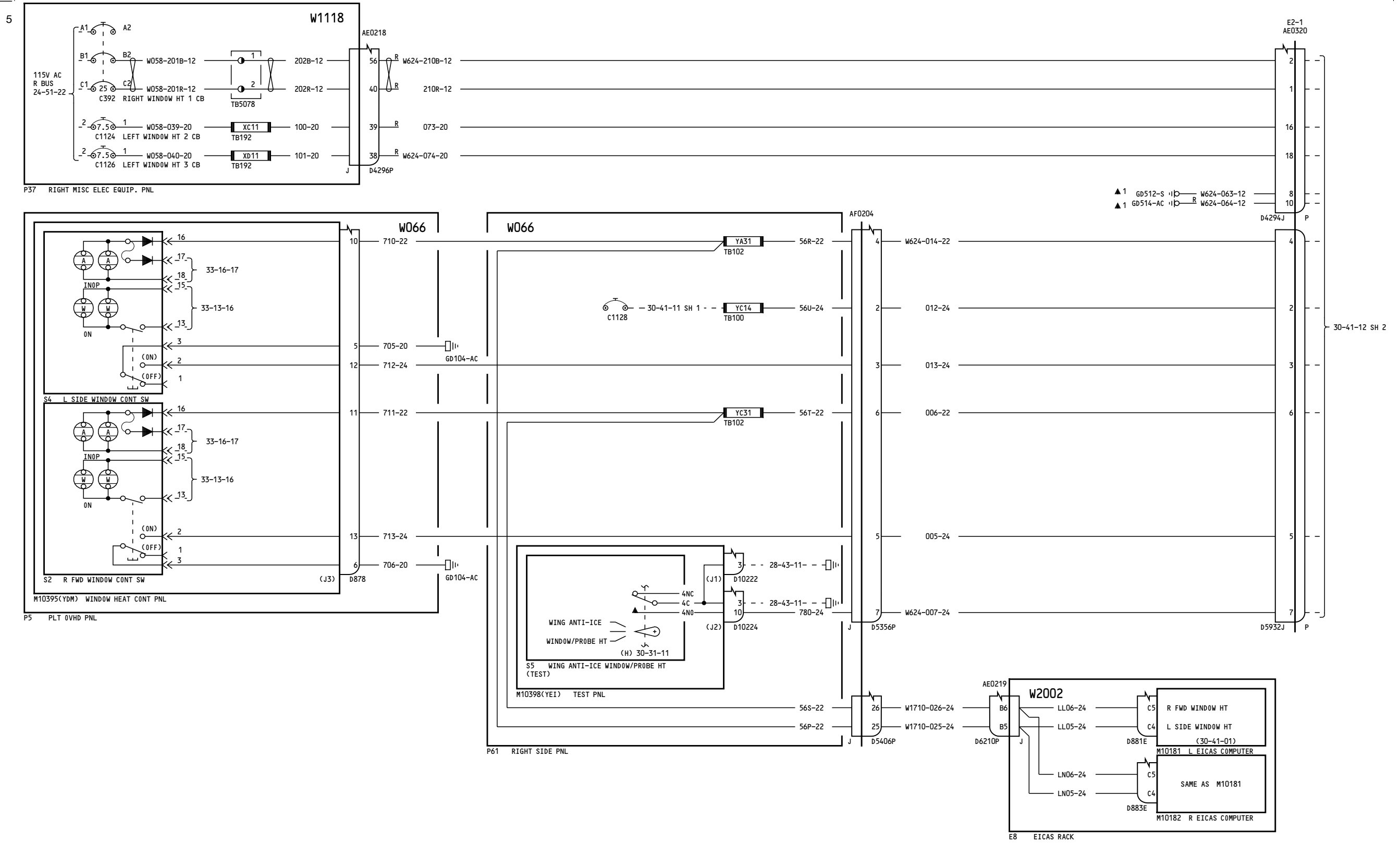

155-199, 277-299

**WINDOW HEAT-
RIGHT FORWARD &
LEFT SIDE**

30-41-12

Page 3
Sheet 1
Jan 21/2005

D280T132

30-41-12

Page 3
Sheet 1
Jan 21/2005

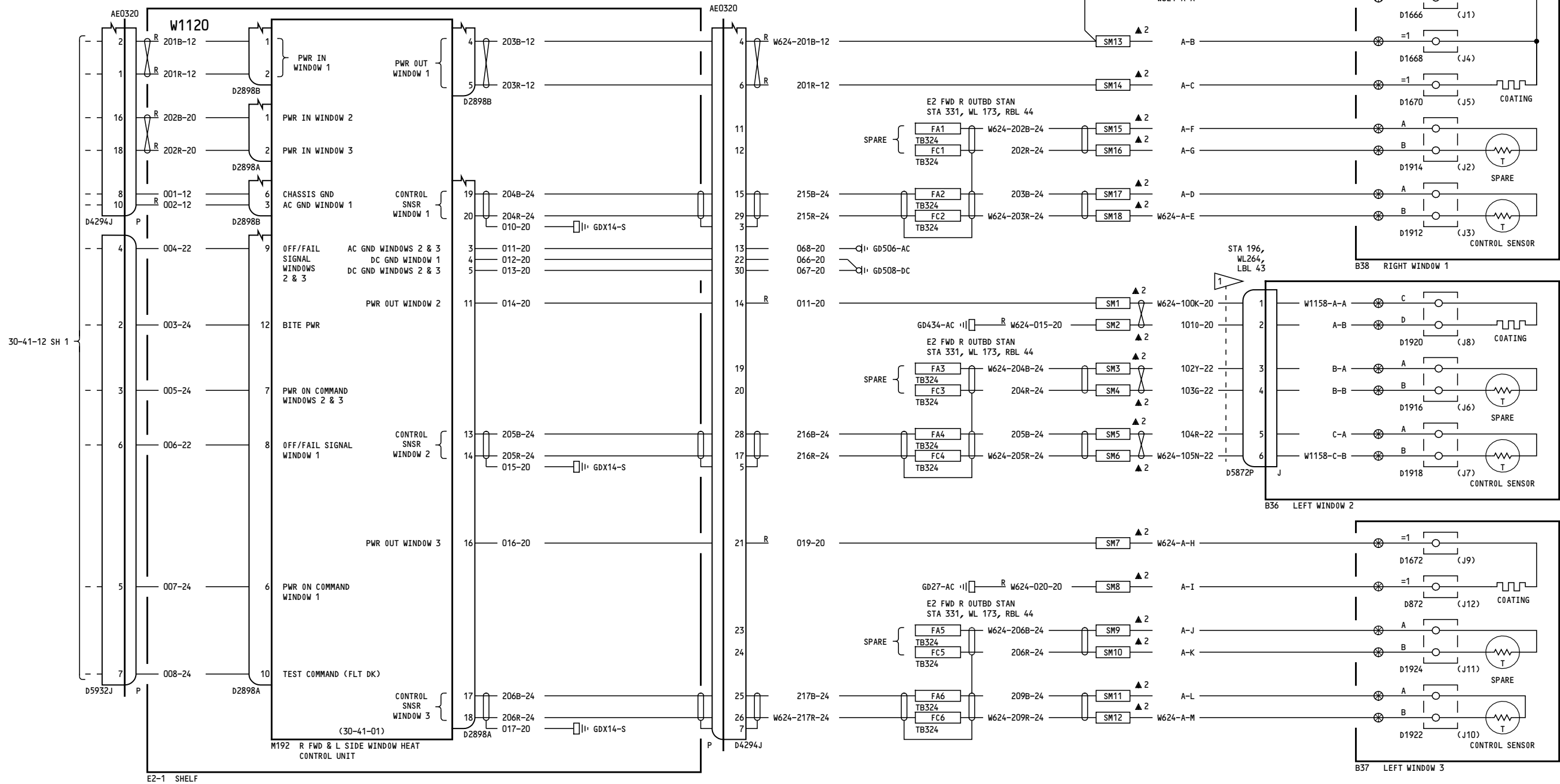

NOTES:
 1 ▷ RETRACTABLE ELECTRICAL CABLE.

155-199, 277-299

**WINDOW HEAT-
 RIGHT FORWARD &
 LEFT SIDE**

D280T132

30-41-12

Page 3
 Sheet 2
 Jan 21/2005

30-41-12

Page 3
 Sheet 2
 Jan 21/2005

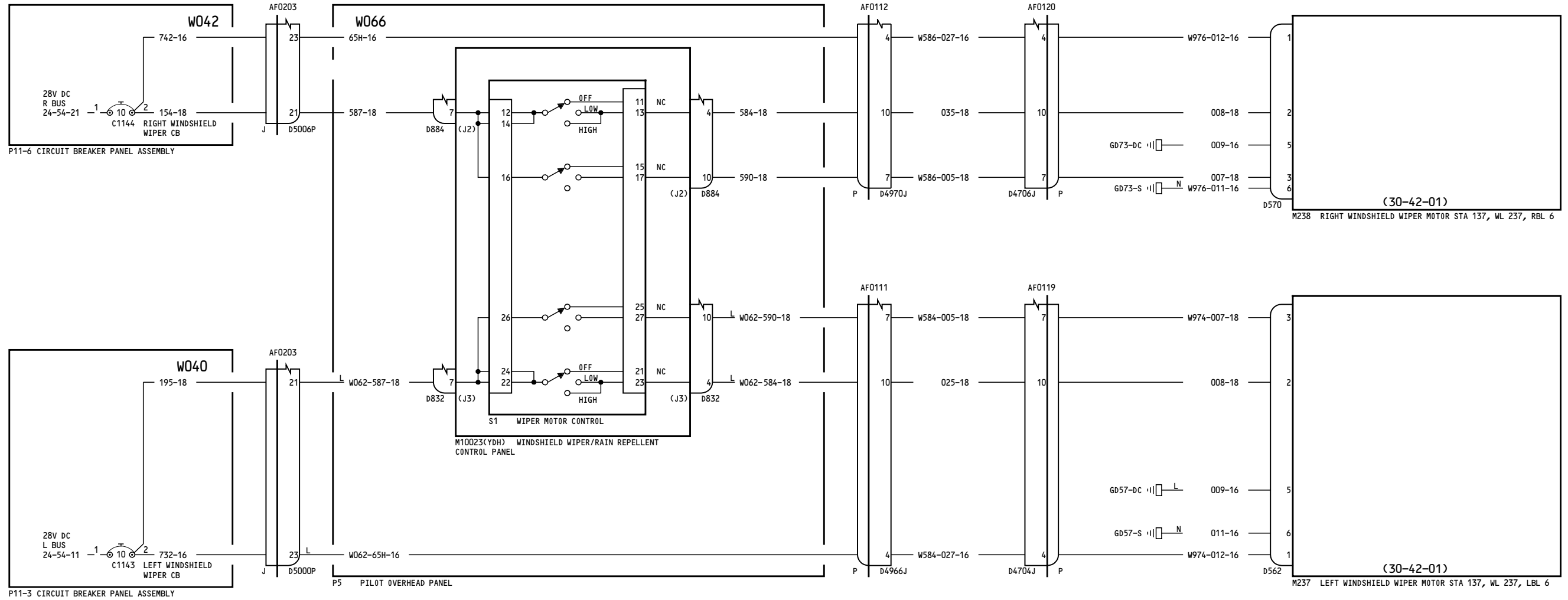

ALL	WINDSHIELD WIPERS
	D280T132

30-42-11

Page 1

Jan 21/2005

30-42-11

Page 1

Jan 21/2005

13

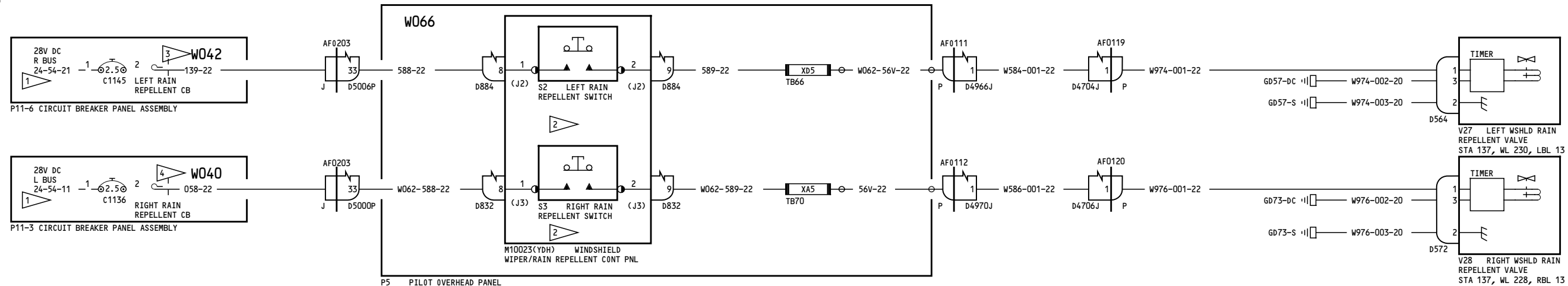

- NOTES:
- 1 COLLAR AND LABEL "INOP"
 - 2 "INOP"
 - 3 CAP & STOW NEAR C1145
 - 4 CAP & STOW NEAR C1136

050-167

WINDSHIELD RAIN REPELLENT

D280T132

30-43-11

Page 1.1

Jan 21/2005

Incorporates
 30-0028

30-43-11

Page 1.1

Jan 21/2005

-C
2

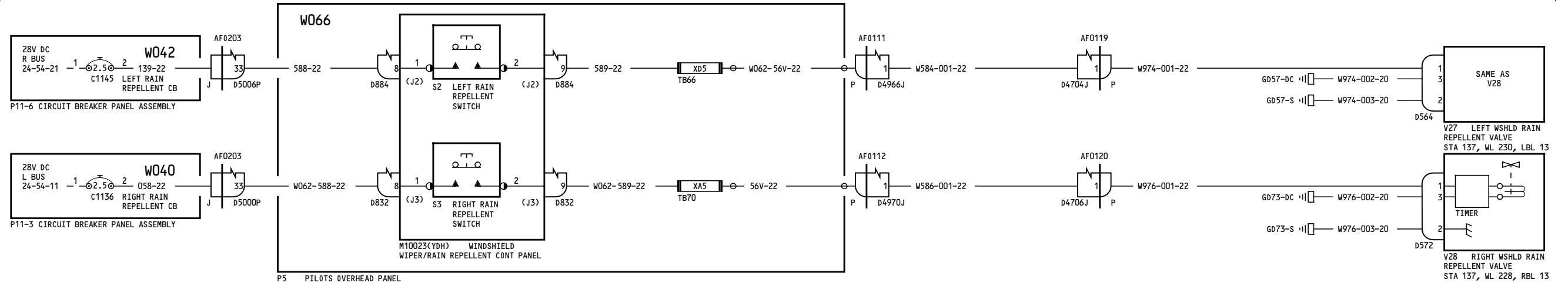

275-278

WINDSHIELD RAIN REPELLENT

D280T132

30-43-11

Page 2

Jan 21/2005

30-43-11

Page 2

Jan 21/2005

16

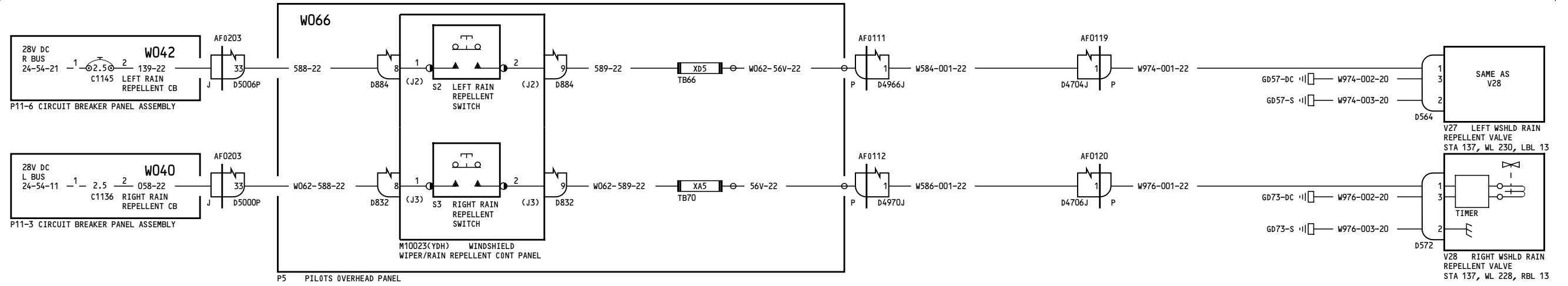

280-299

WINDSHIELD RAIN REPELLENT

D280T132

30-43-11

Page 3

Jan 21/2005

30-43-11

Page 3

Jan 21/2005

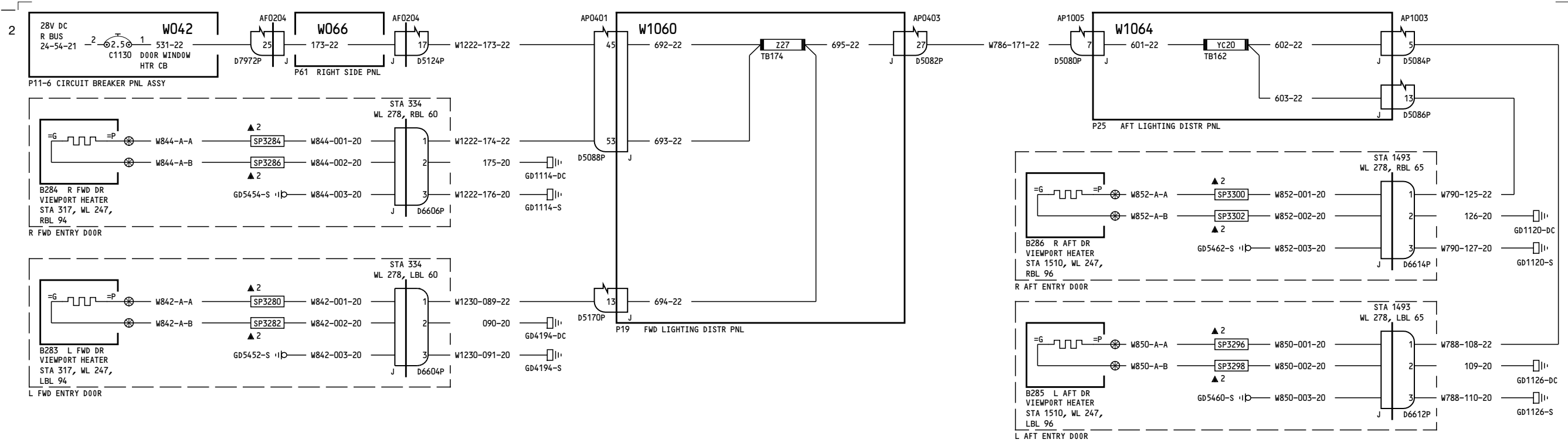

ALL

**VIEWPORT HEATERS
ENTRY/SERVICE DOORS**

D280T132

30-46-11

Page 1

Jan 21/2005

30-46-11

Page 1

Jan 21/2005

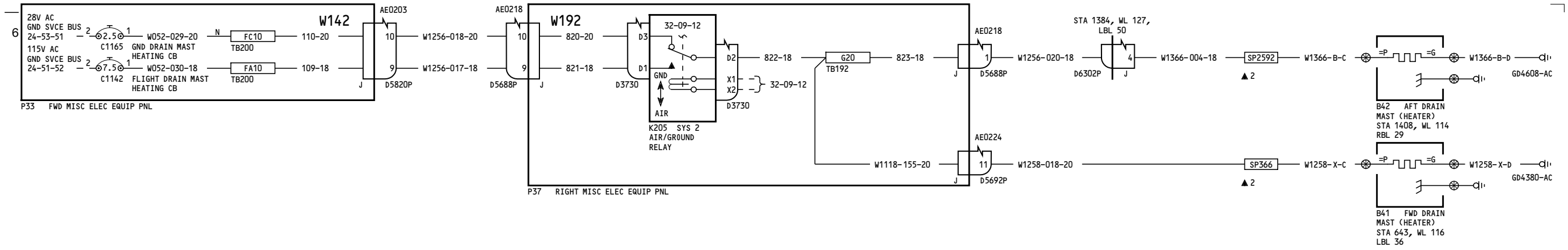

050-099

DRAIN MAST HEATING

30-71-11

Page 1

D280T132

Jan 21/2005

30-71-11

Page 1

Jan 21/2005

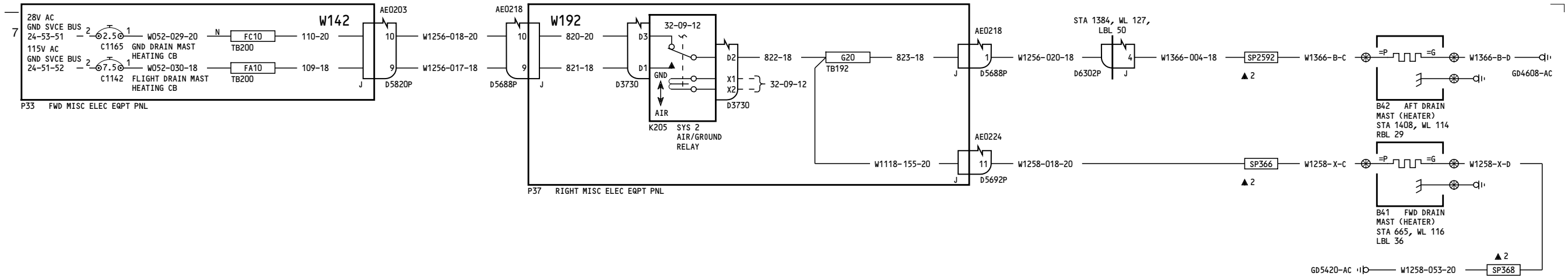

150-199, 275-278

DRAIN MAST HEATING

30-71-11

Page 2

D280T132

Jan 21/2005

30-71-11

Page 2

Jan 21/2005

13

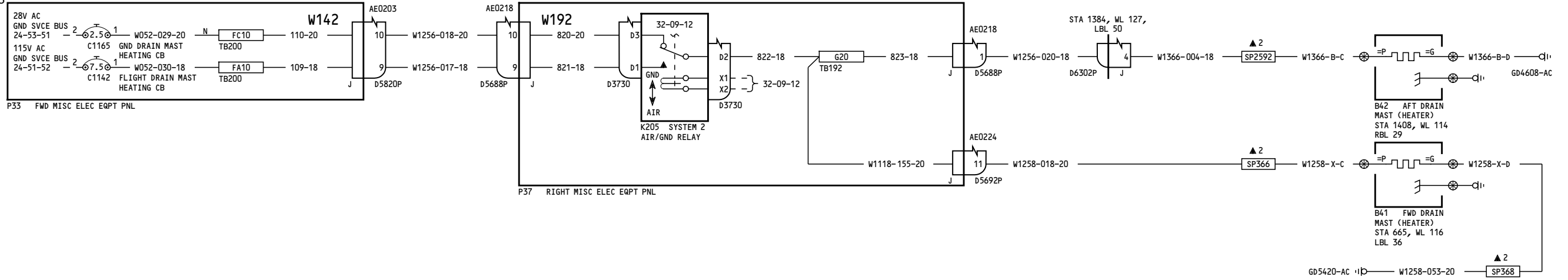

280-299

DRAIN MAST HEATING

30-71-11

Page 3

D280T132

Jan 21/2005

30-71-11

Page 3

Jan 21/2005

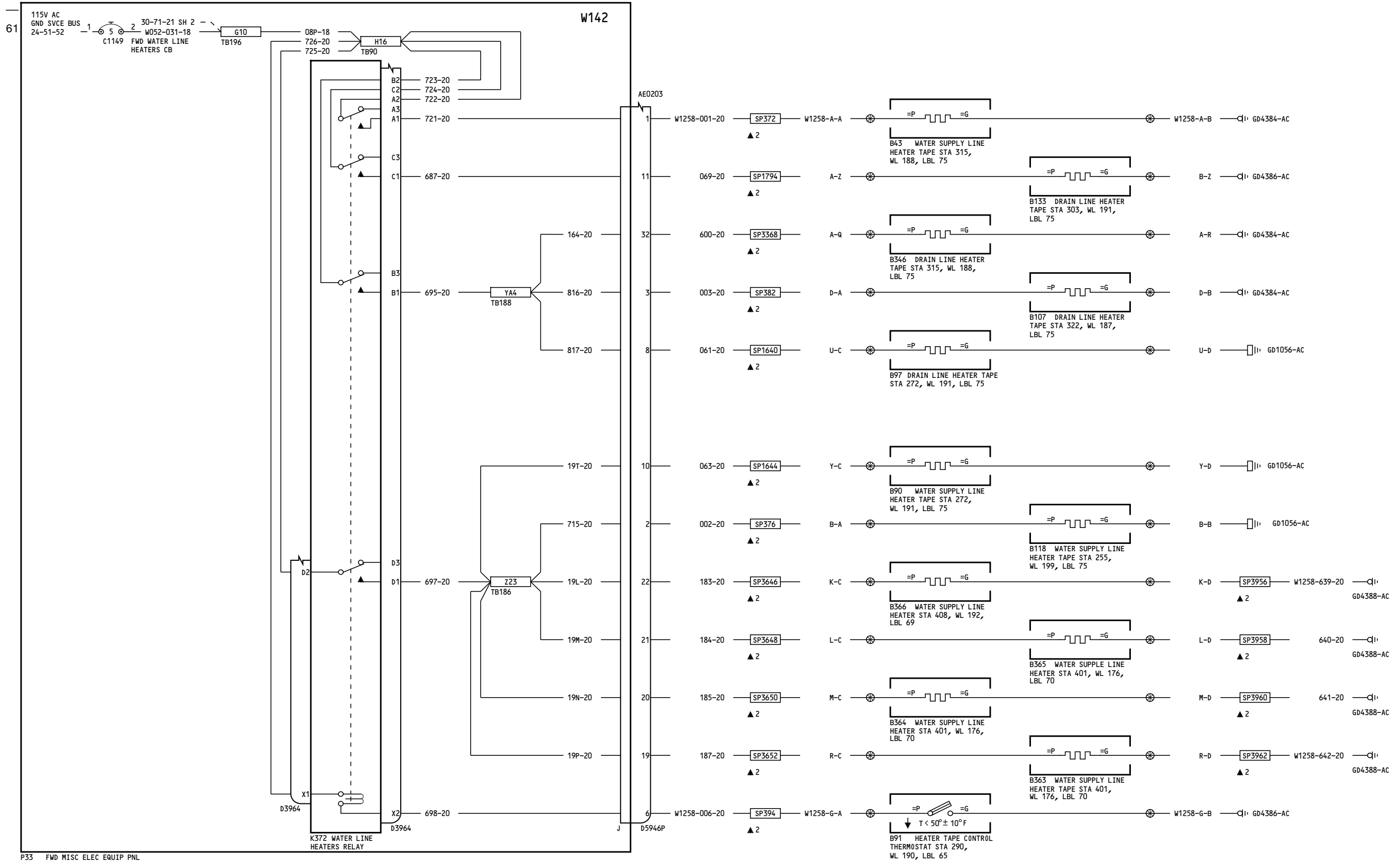

P33 FWD MISC ELEC EQUIP PNL

050-099

FORWARD WATER SUPPLY LINE & DRAIN LINE HEATERS

D280T132

30-71-21

Page 1
Sheet 1
Jan 21/2005

30-71-21

Page 1
Sheet 1
Jan 21/2005

61

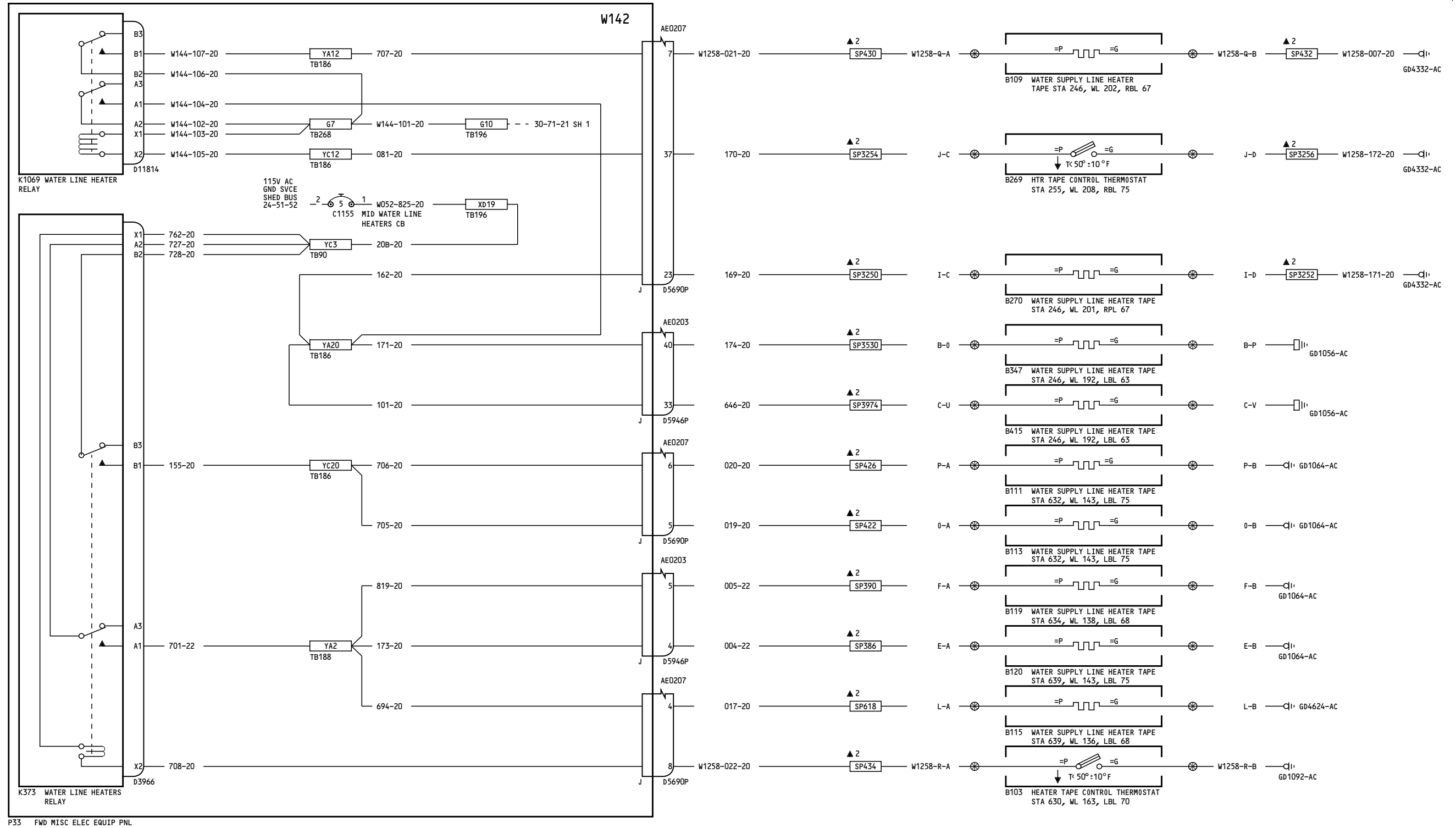

050-099

FORWARD WATER SUPPLY LINE & DRAIN LINE HEATERS

30-71-21

Page 1
Sheet 2
Jan 21/2005

D280T132

30-71-21

Page 1
Sheet 2
Jan 21/2005

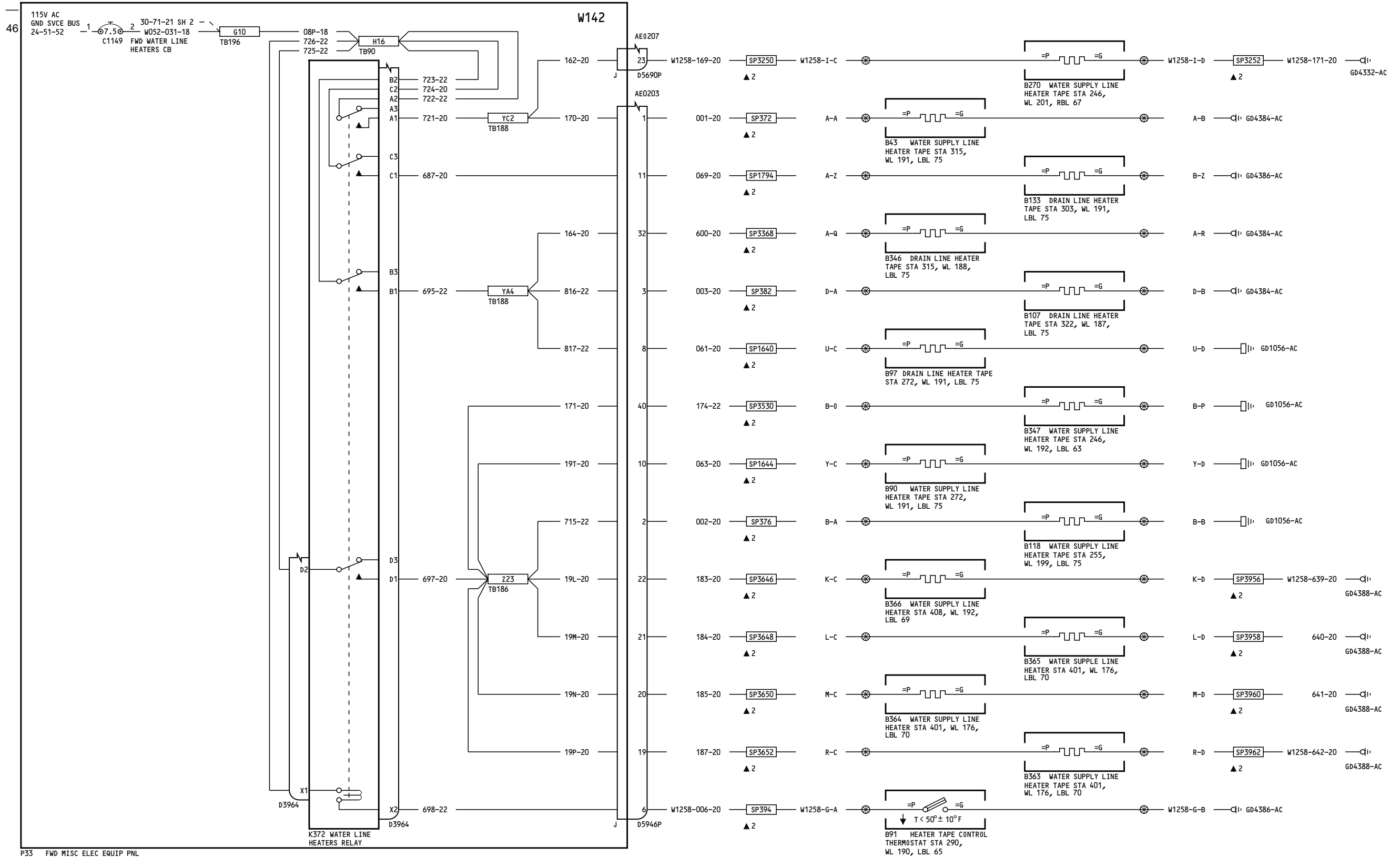

P33 FWD MISC ELEC EQUIP PNL

150-154

FORWARD WATER SUPPLY LINE & DRAIN LINE HEATERS

D280T132

30-71-21

Page 2
Sheet 1
Jan 21/2005

30-71-21

Page 2
Sheet 1
Jan 21/2005

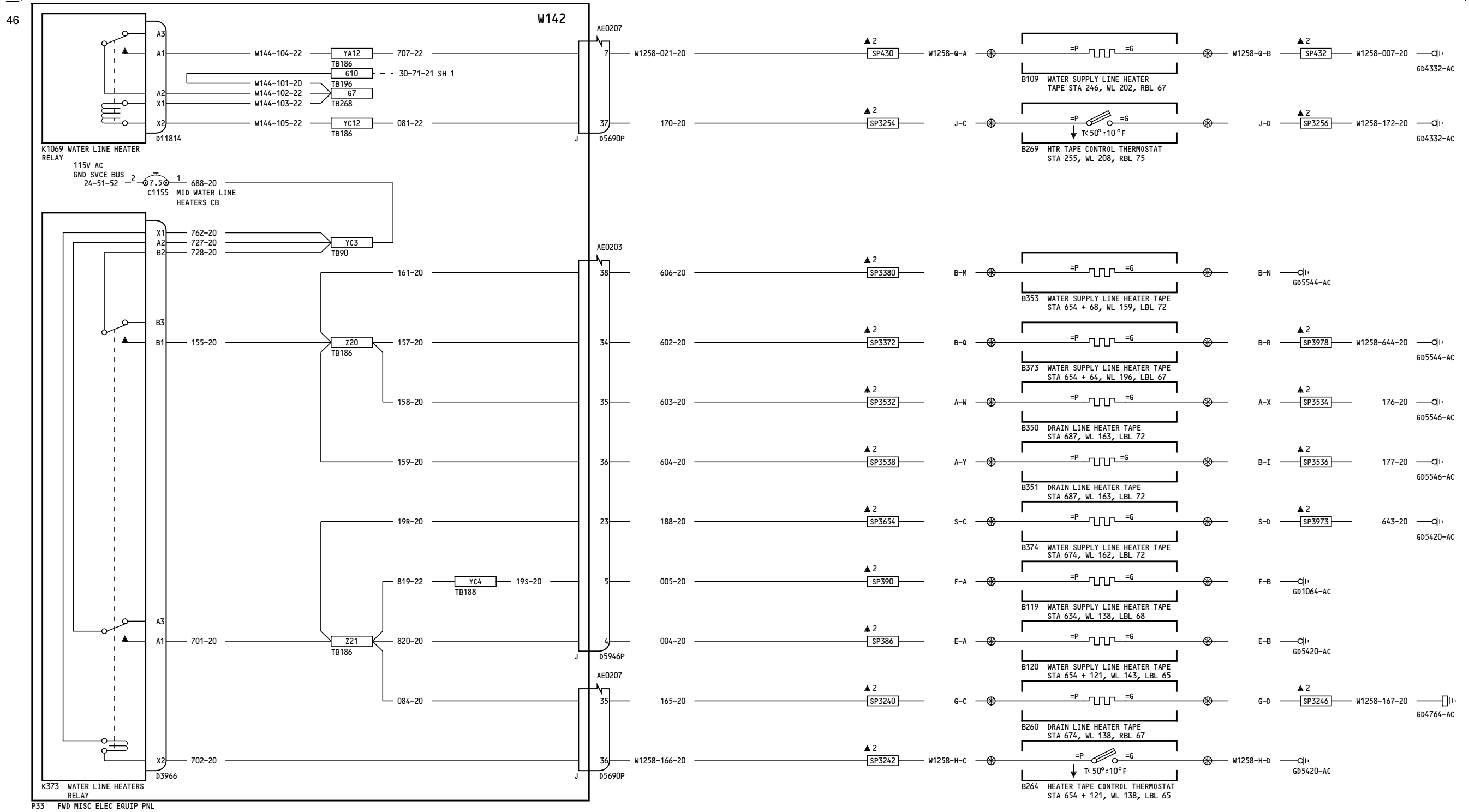

150-154

FORWARD WATER SUPPLY LINE & DRAIN LINE HEATERS

30-71-21

Page 2
Sheet 2
Jan 21/2005

D280T132

30-71-21

Page 2
Sheet 2
Jan 21/2005

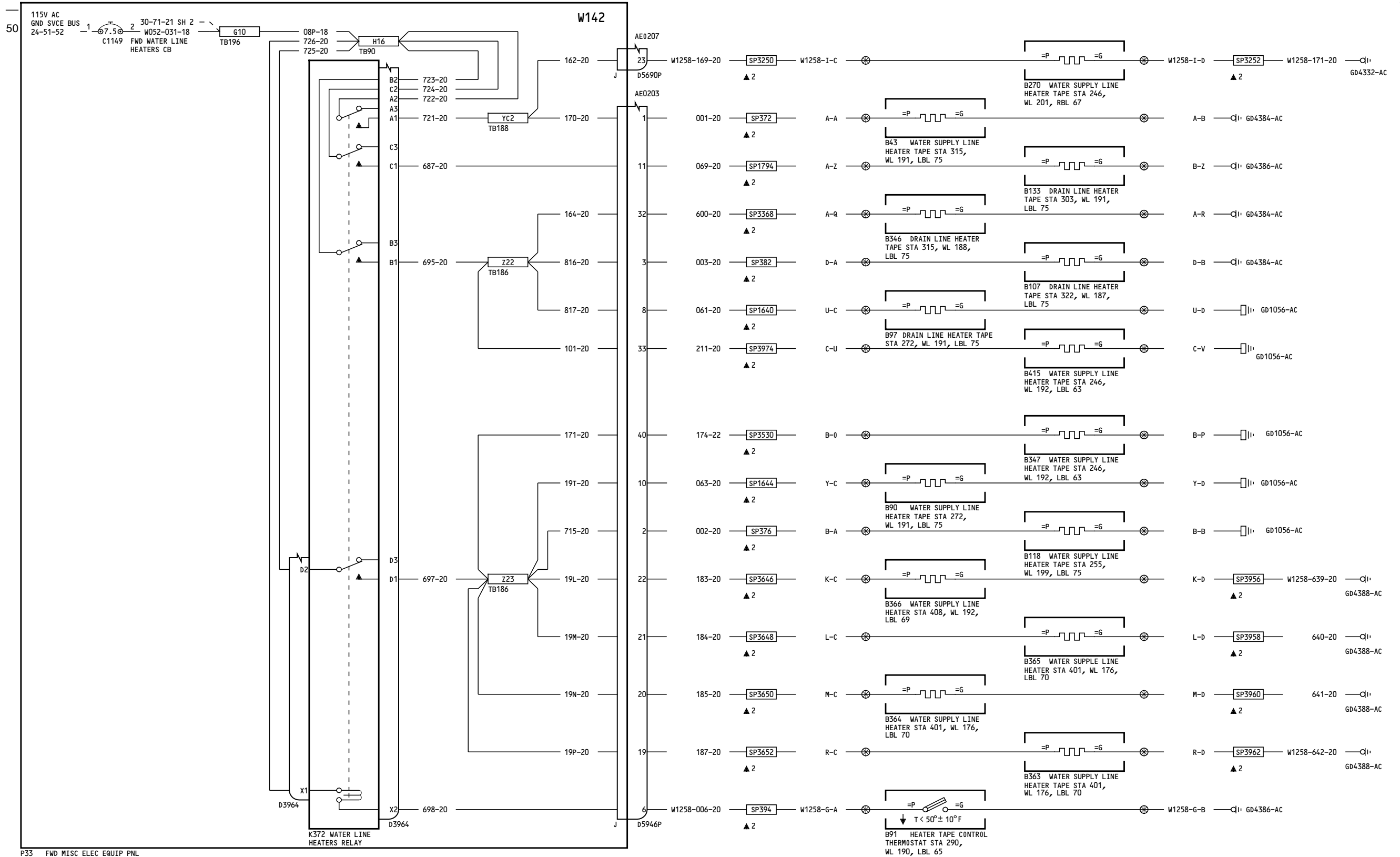

P33 FWD MISC ELEC EQUIP PNL

155-199

FORWARD WATER SUPPLY LINE & DRAIN LINE HEATERS

D280T132

30-71-21

Page 3
Sheet 1
Jan 21/2005

30-71-21

Page 3
Sheet 1
Jan 21/2005

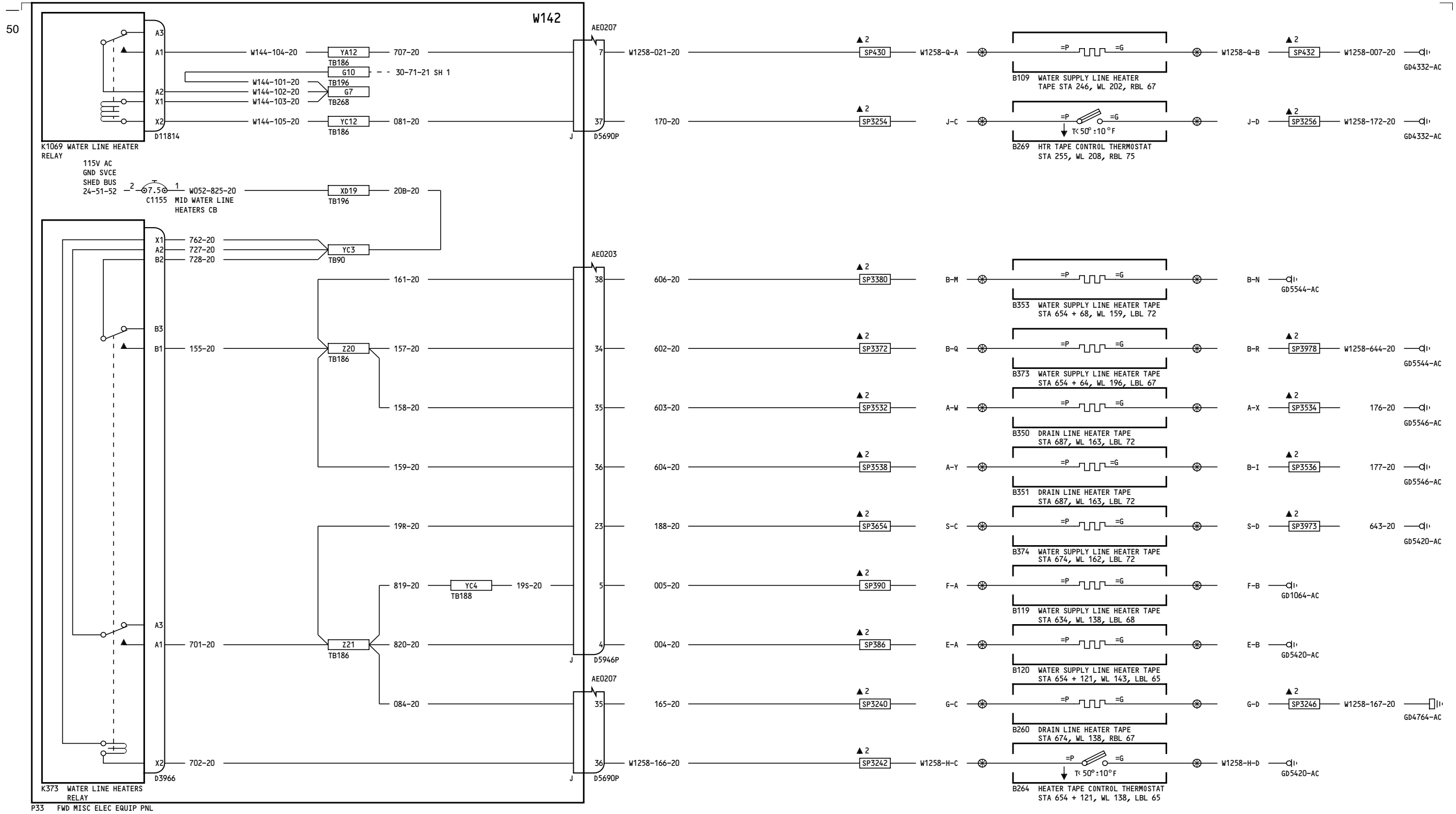

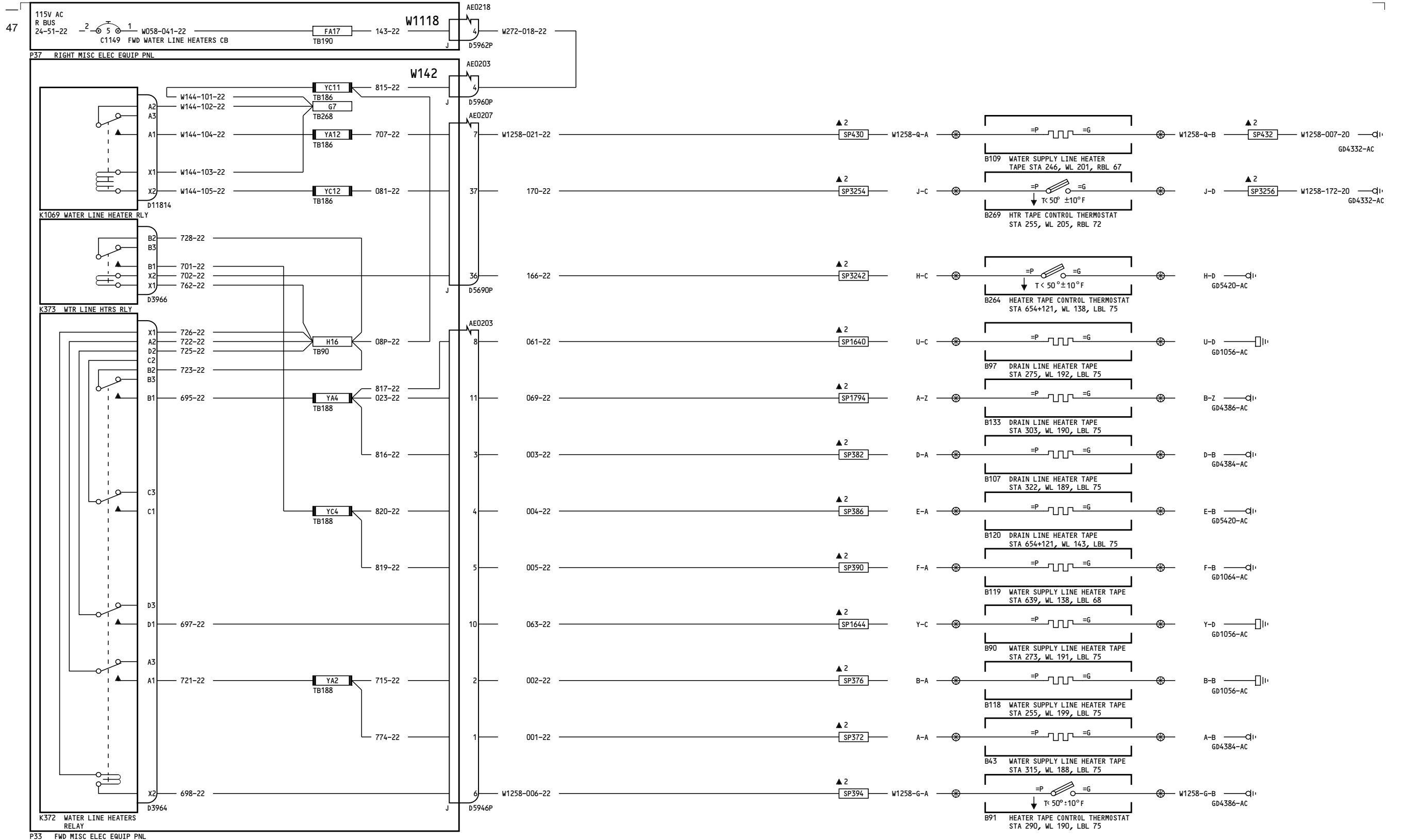

275

FORWARD WATER SUPPLY LINE & DRAIN LINE HEATERS

D280T132

30-71-21

Page 4

Jan 21/2005

30-71-21

Page 4

Jan 21/2005

59

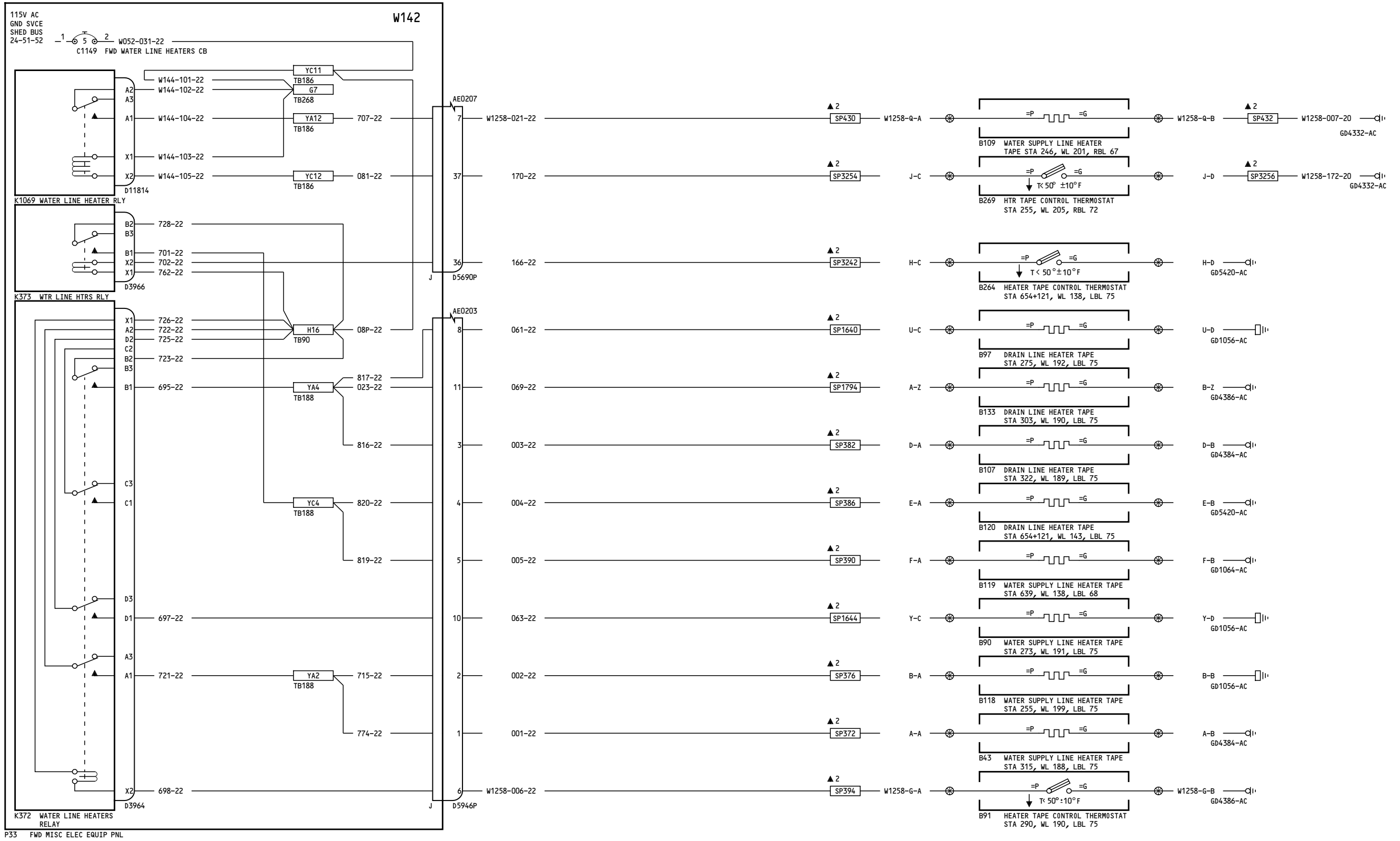

276

FORWARD WATER SUPPLY LINE & DRAIN LINE HEATERS

30-71-21

Page 5

Jan 21/2005

D280T132

30-71-21

Page 5

Jan 21/2005

65

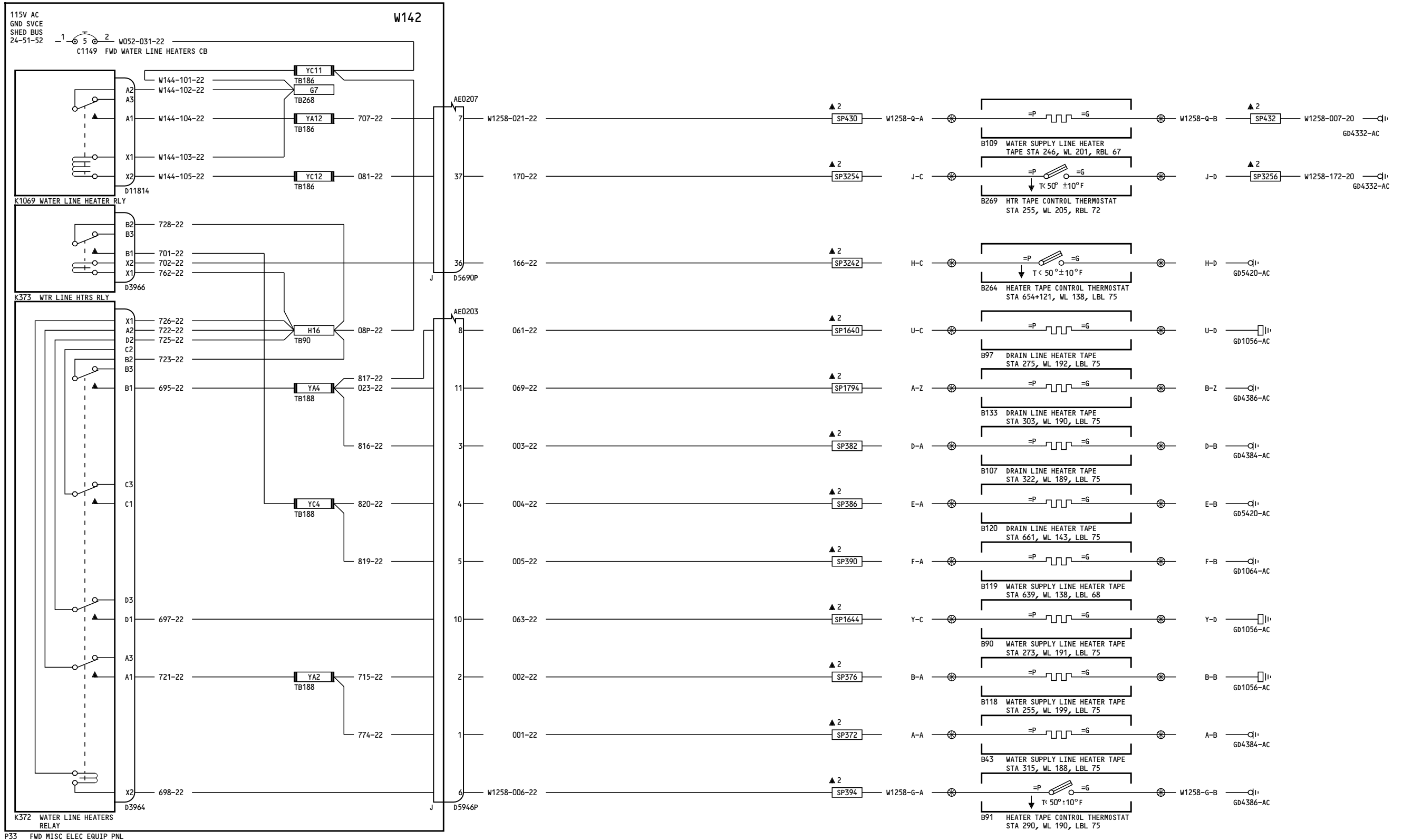

277-278

FORWARD WATER SUPPLY LINE & DRAIN LINE HEATERS

30-71-21

Page 6

Jan 21/2005

D280T132

30-71-21

Page 6

Jan 21/2005

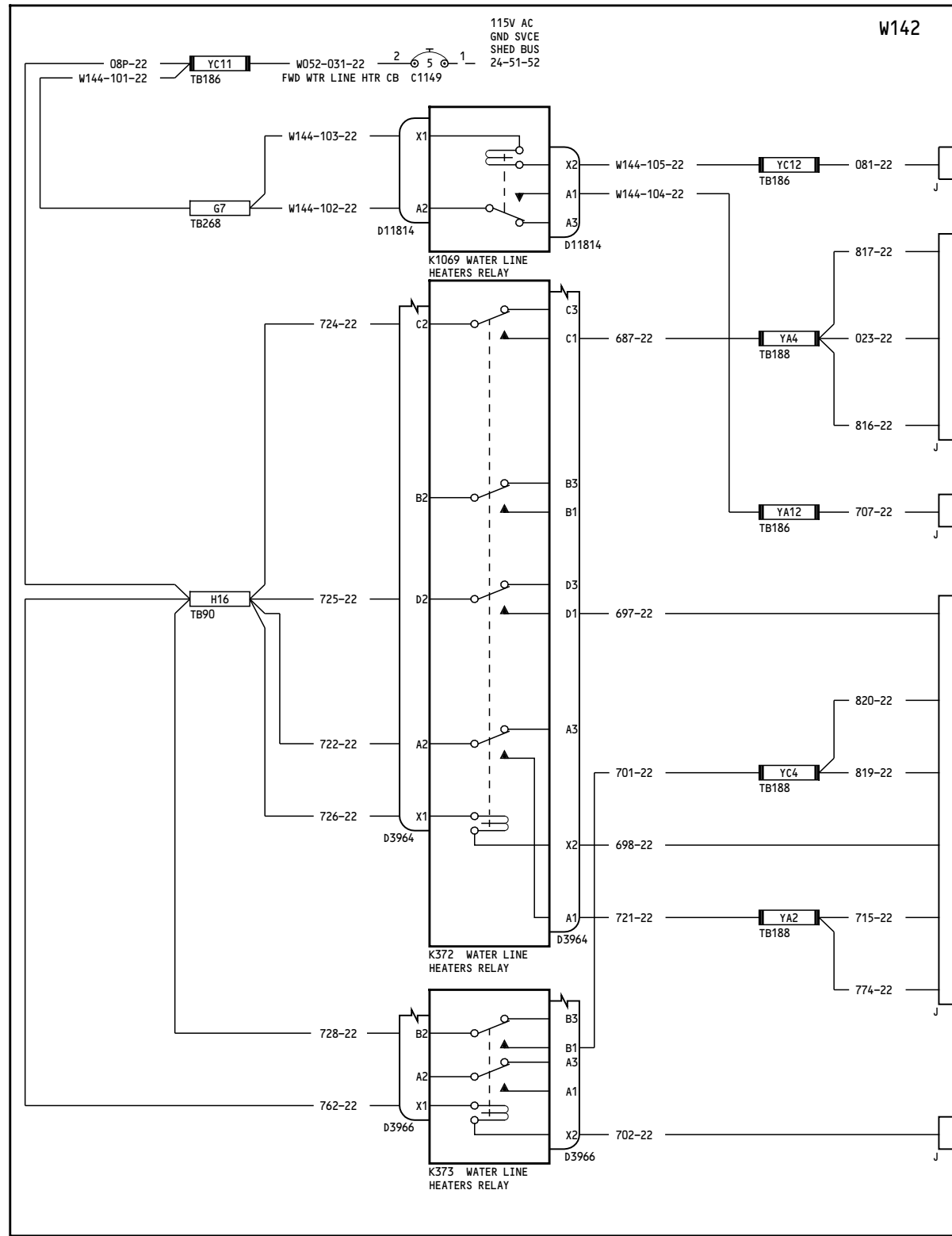

P33 FWD MISC ELEC EQPT PNL

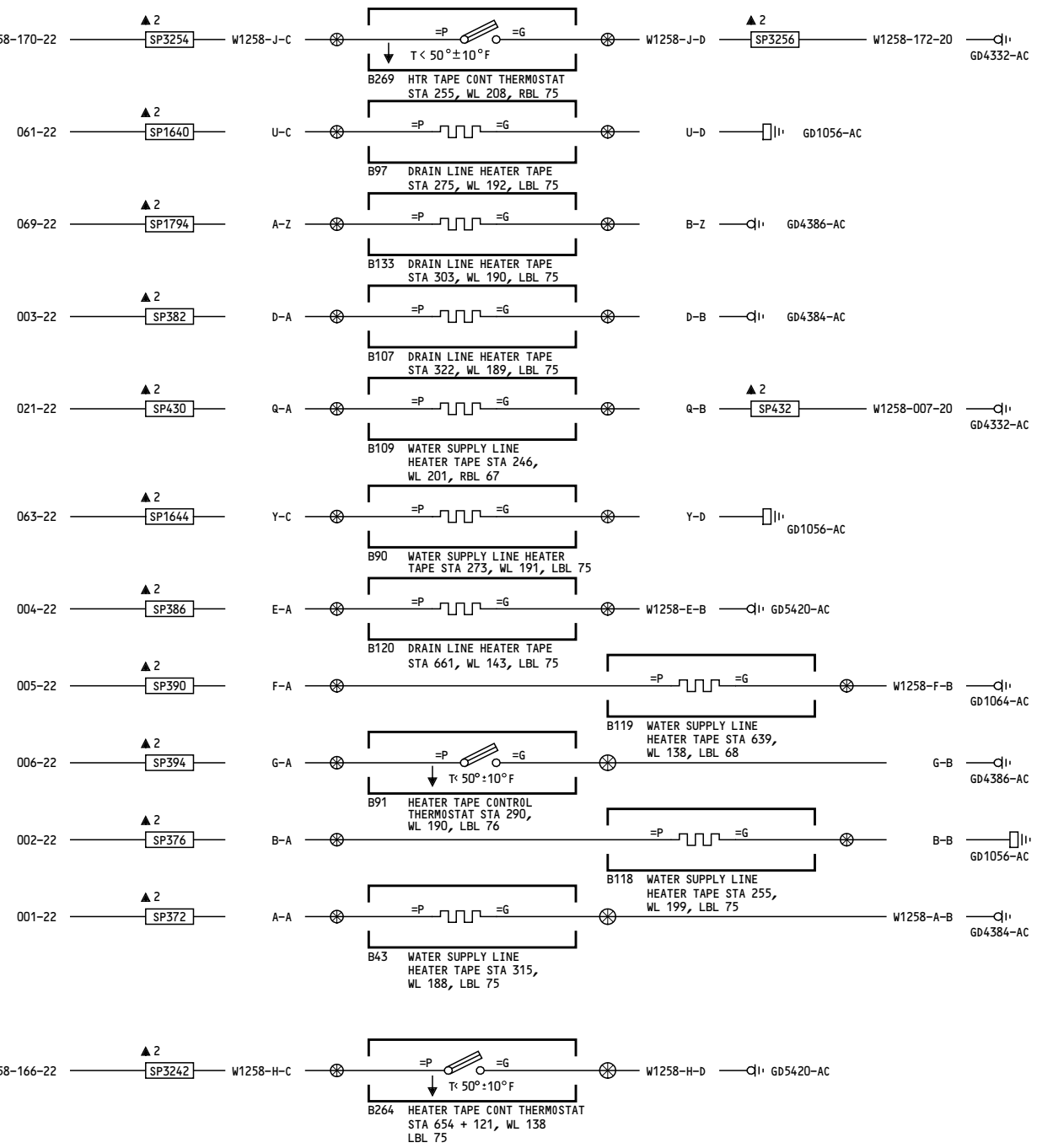

280-299

FORWARD WATER SUPPLY LINE & DRAIN LINE HEATERS

30-71-21

Page 7

D280T132

Jan 21/2005

30-71-21

Page 7

Jan 21/2005

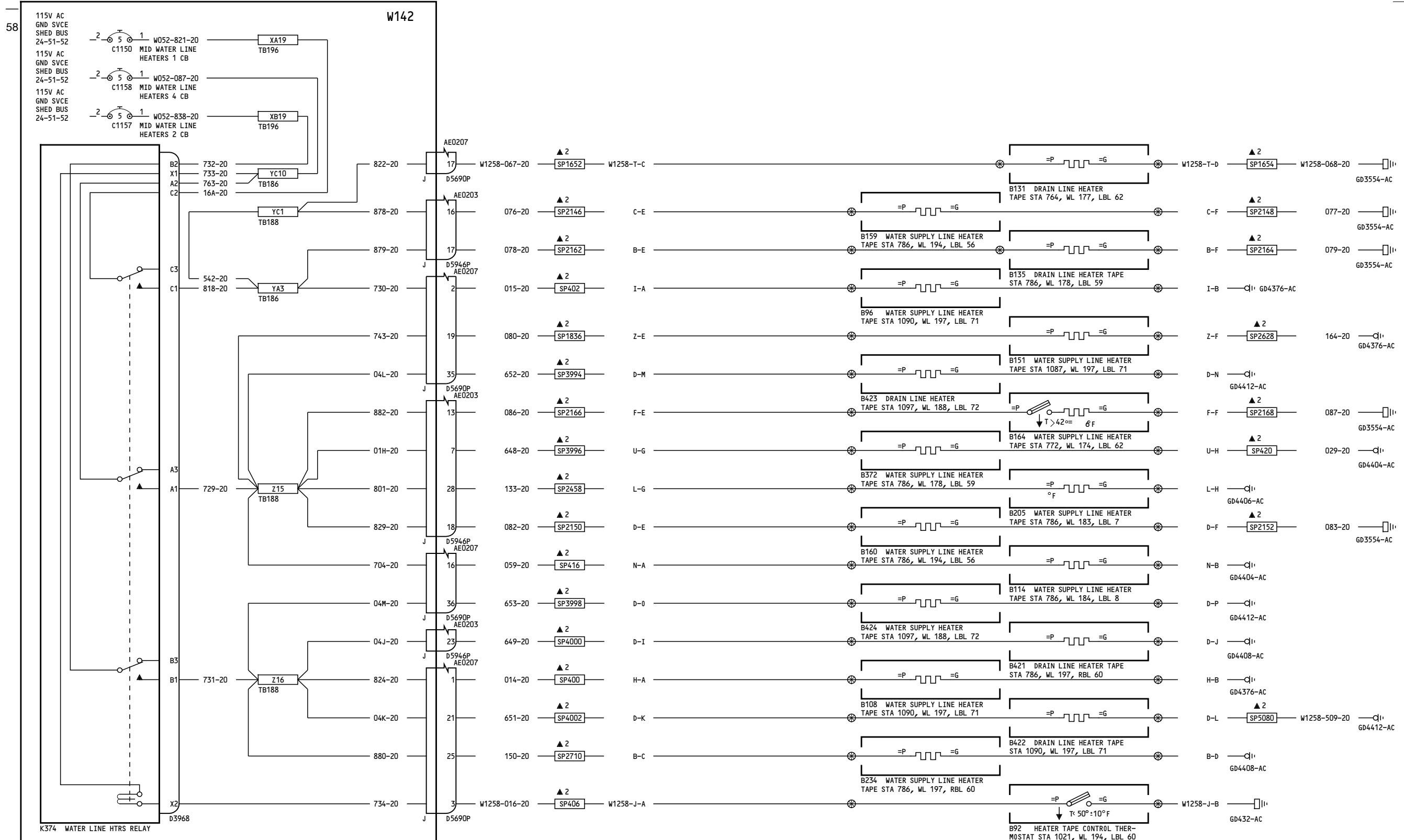

P33 FORWARD MISCELLANEOUS ELECTRICAL EQUIPMENT PANEL

050-099

MID WATER SUPPLY LINE & DRAIN LINE HEATERS

30-71-22

Page 1

D280T132

Jan 21/2005

30-71-22

Page 1

Jan 21/2005

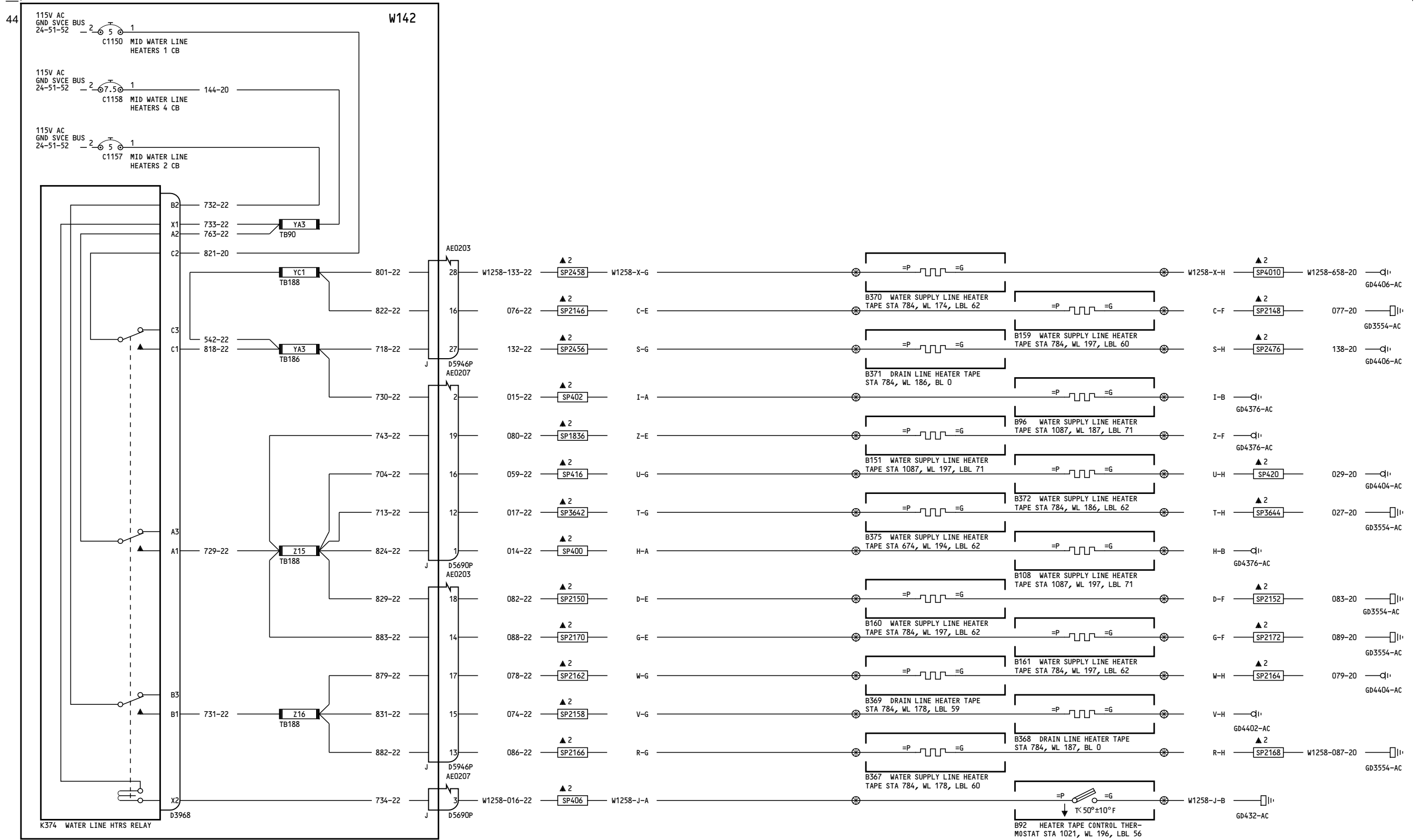

150-154

MID WATER SUPPLY LINE & DRAIN LINE HEATERS

30-71-22

Page 2

D280T132

Jan 21/2005

30-71-22

Page 2

Jan 21/2005

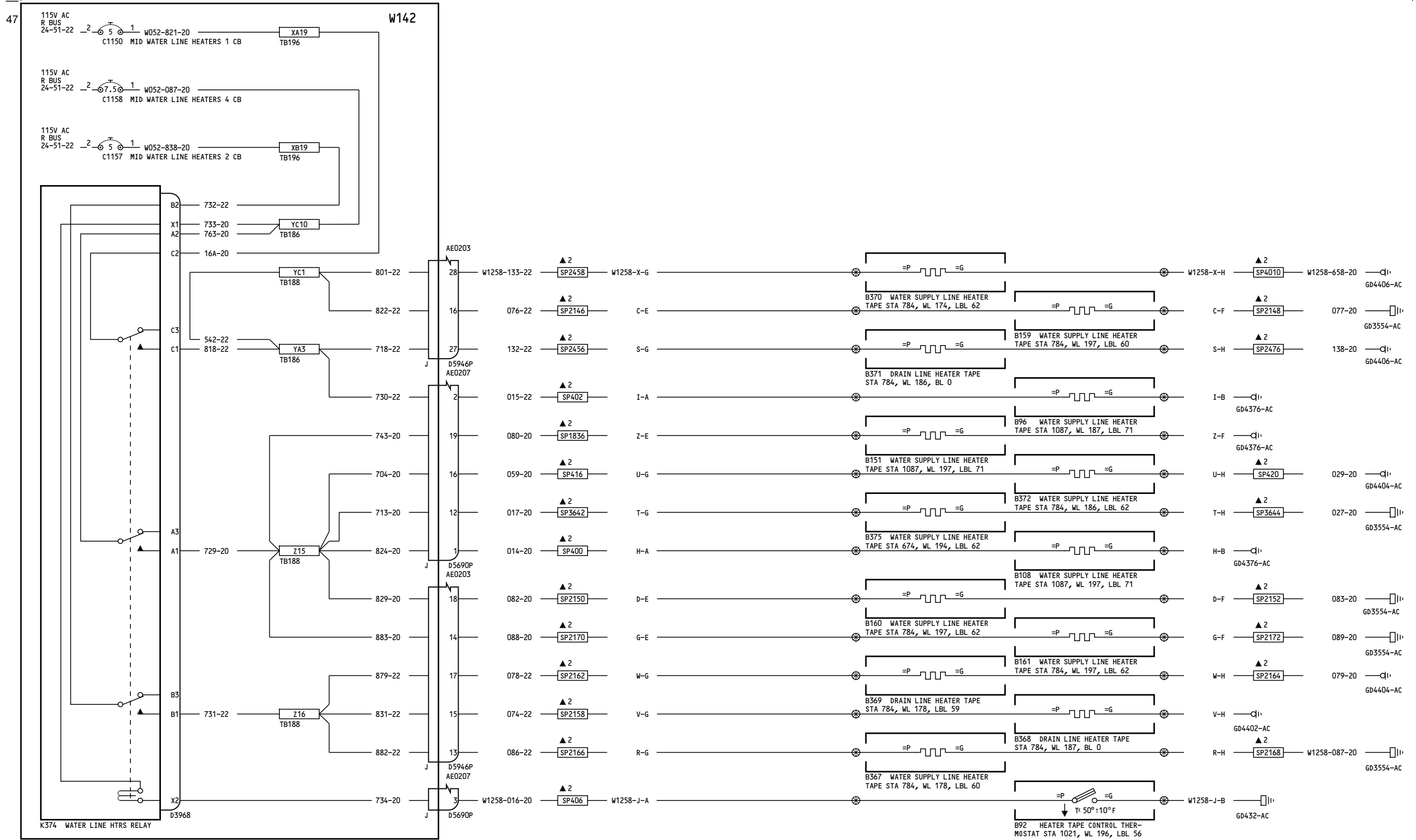

P33 FORWARD MISCELLANEOUS ELECTRICAL EQUIPMENT PANEL

155-199

MID WATER SUPPLY LINE & DRAIN LINE HEATERS

30-71-22

Page 3

D280T132

Jan 21/2005

30-71-22

Page 3

Jan 21/2005

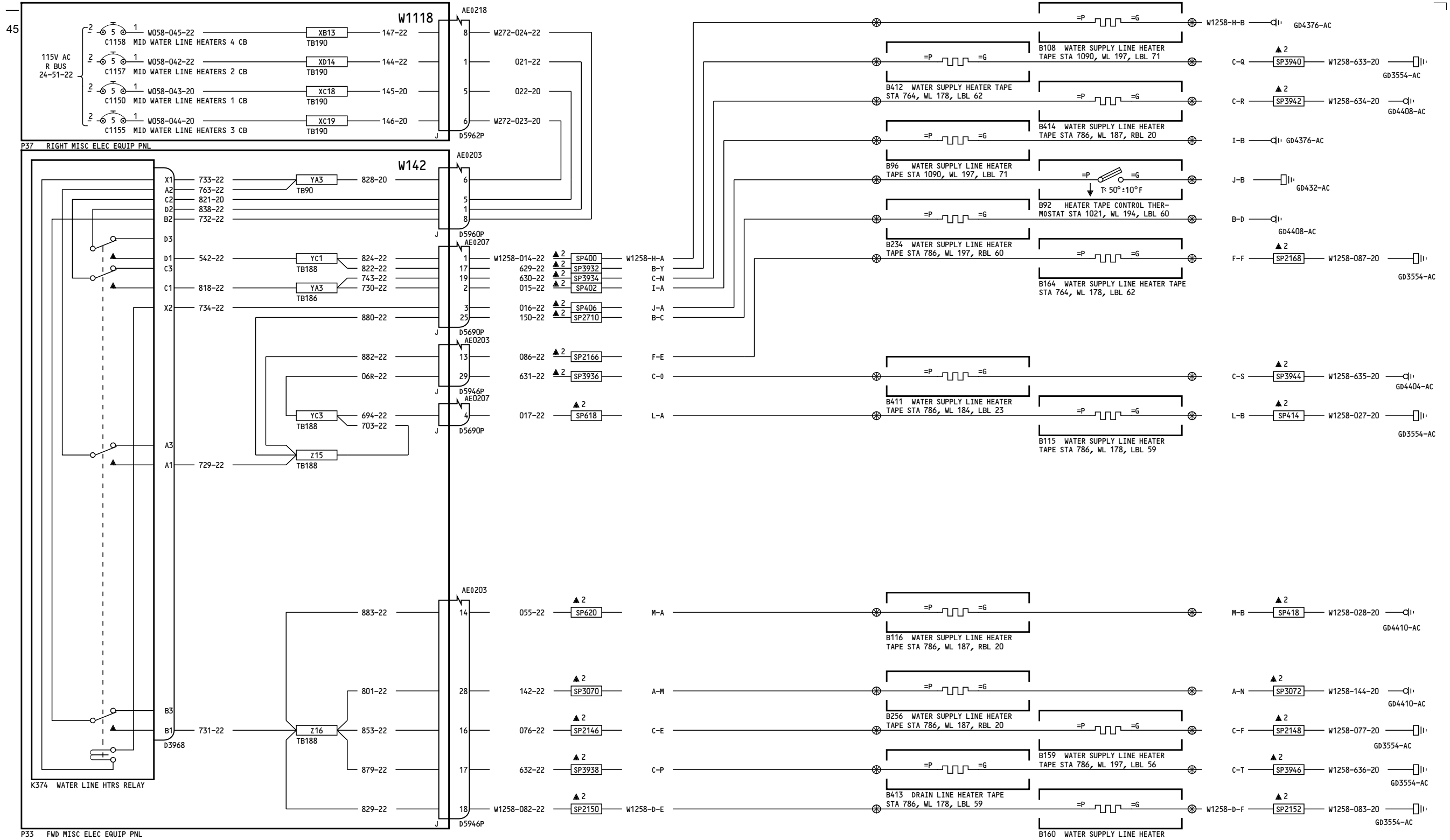

275

MID WATER SUPPLY LINE & DRAIN LINE HEATERS

30-71-22

Page 4

D280T132

Jan 21/2005

30-71-22

Page 4

Jan 21/2005

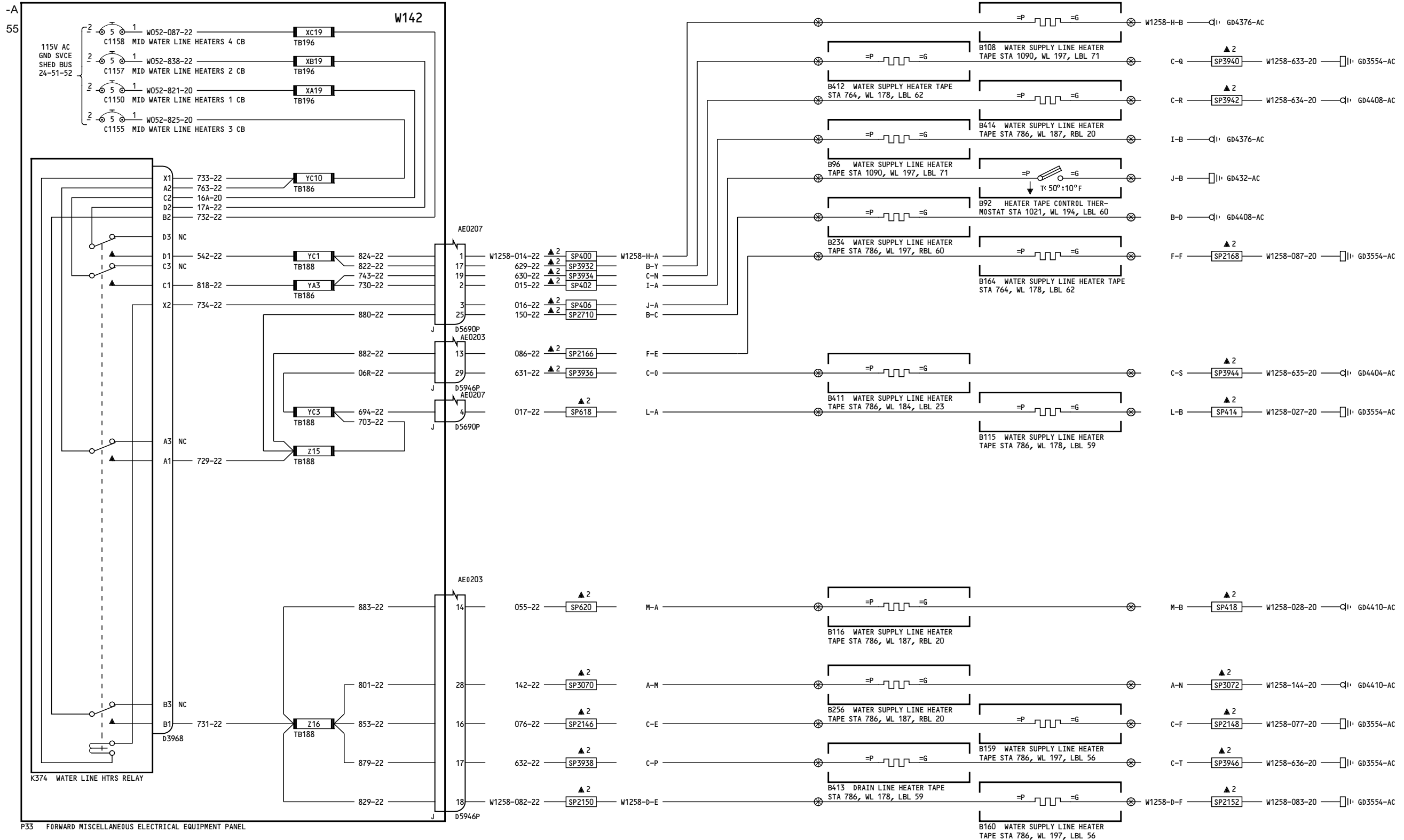

P33 FORWARD MISCELLANEOUS ELECTRICAL EQUIPMENT PANEL

276-299

MID WATER SUPPLY LINE & DRAIN LINE HEATERS

30-71-22

Page 5

D280T132

Jan 21/2005

30-71-22

Page 5

Jan 21/2005

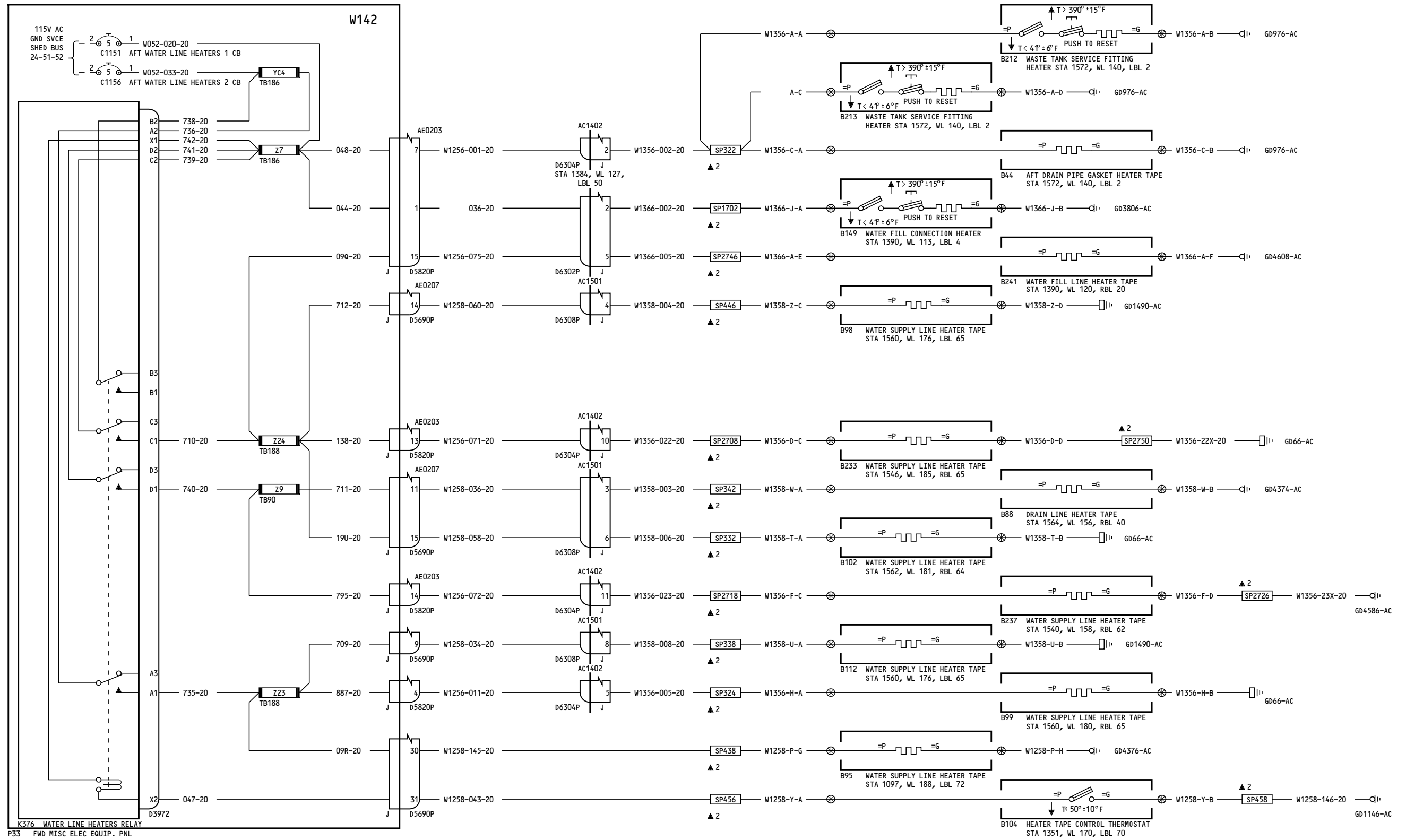

K376 WATER LINE HEATERS RELAY
P33 FWD MISC ELEC EQUIP. PNL

050-099

**AFT WATER SUPPLY LINE &
DRAIN LINE HEATERS**

30-71-23

Page 1

D280T132

Jan 21/2005

30-71-23

Page 1

Jan 21/2005

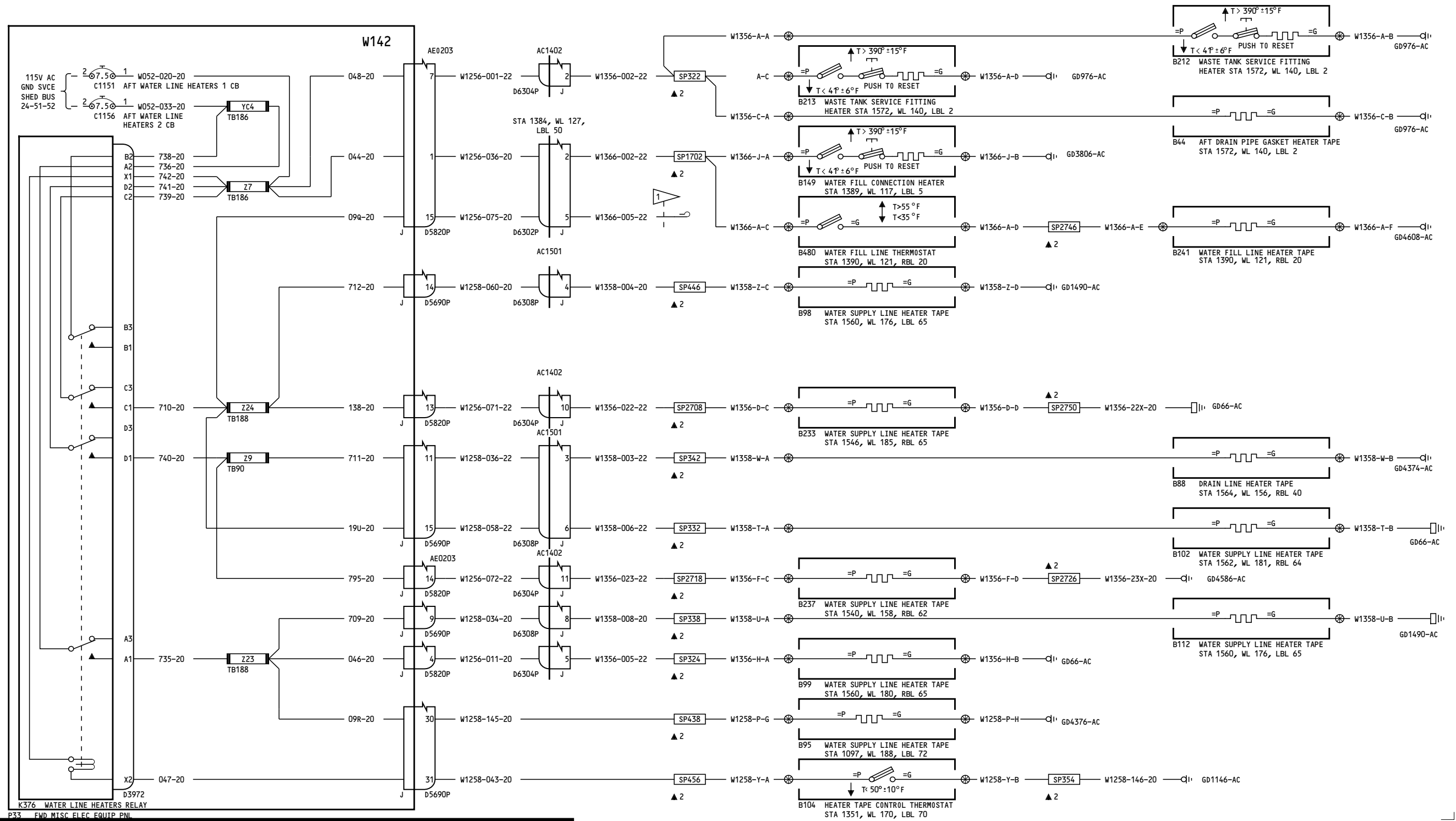

050-051

AFT WATER SUPPLY LINE & DRAIN LINE HEATERS

D280T132

30-71-23

Page 1.1
Jan 21/2005

Incorporates & STOW NEAR SP2746
30-0024

30-71-23

Page 1.1
Jan 21/2005

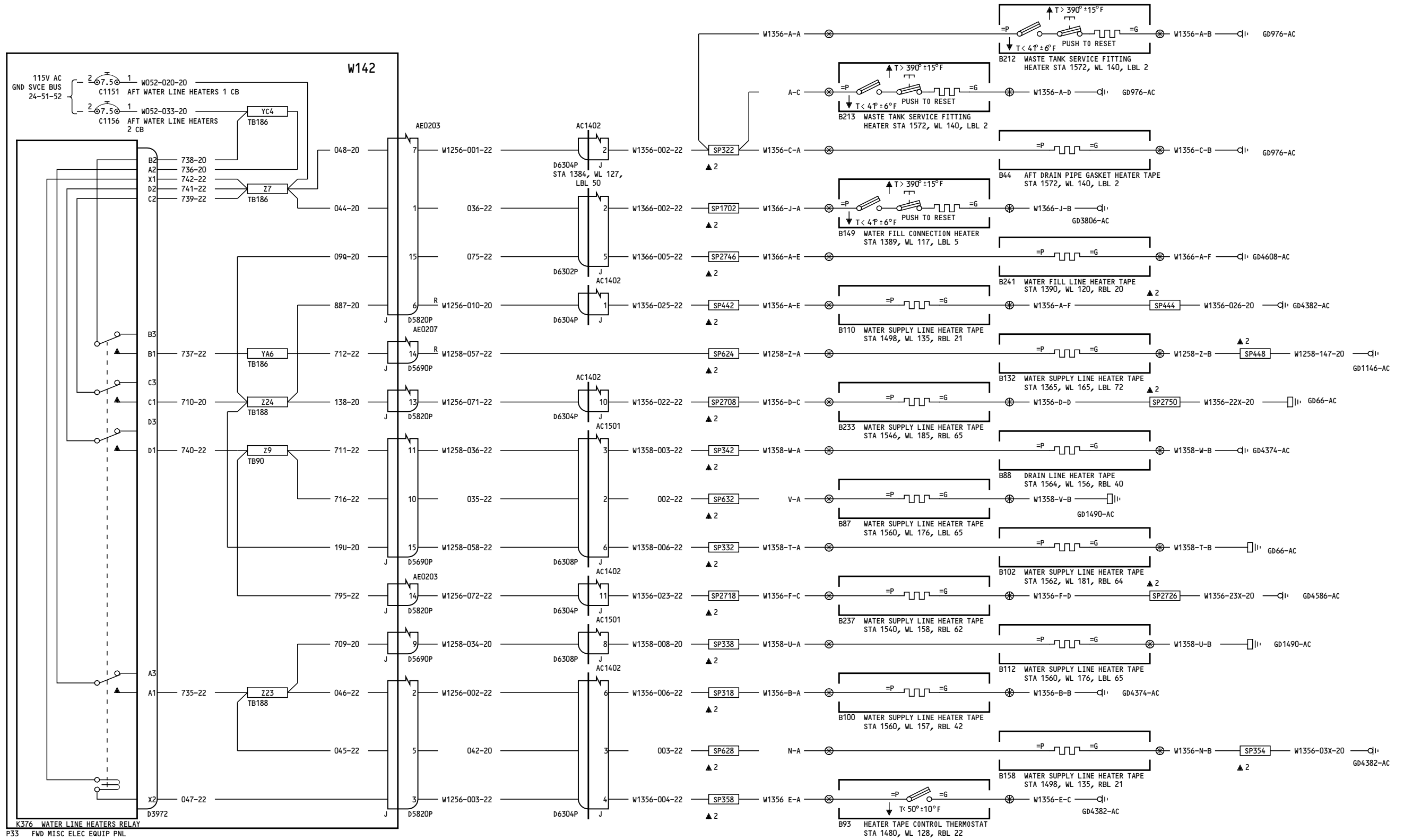

150-154

AFT WATER SUPPLY LINE & DRAIN LINE HEATERS

30-71-23

Page 2

D280T132

Jan 21/2005

30-71-23

Page 2

Jan 21/2005

30-71-23

Page 2

Jan 21/2005

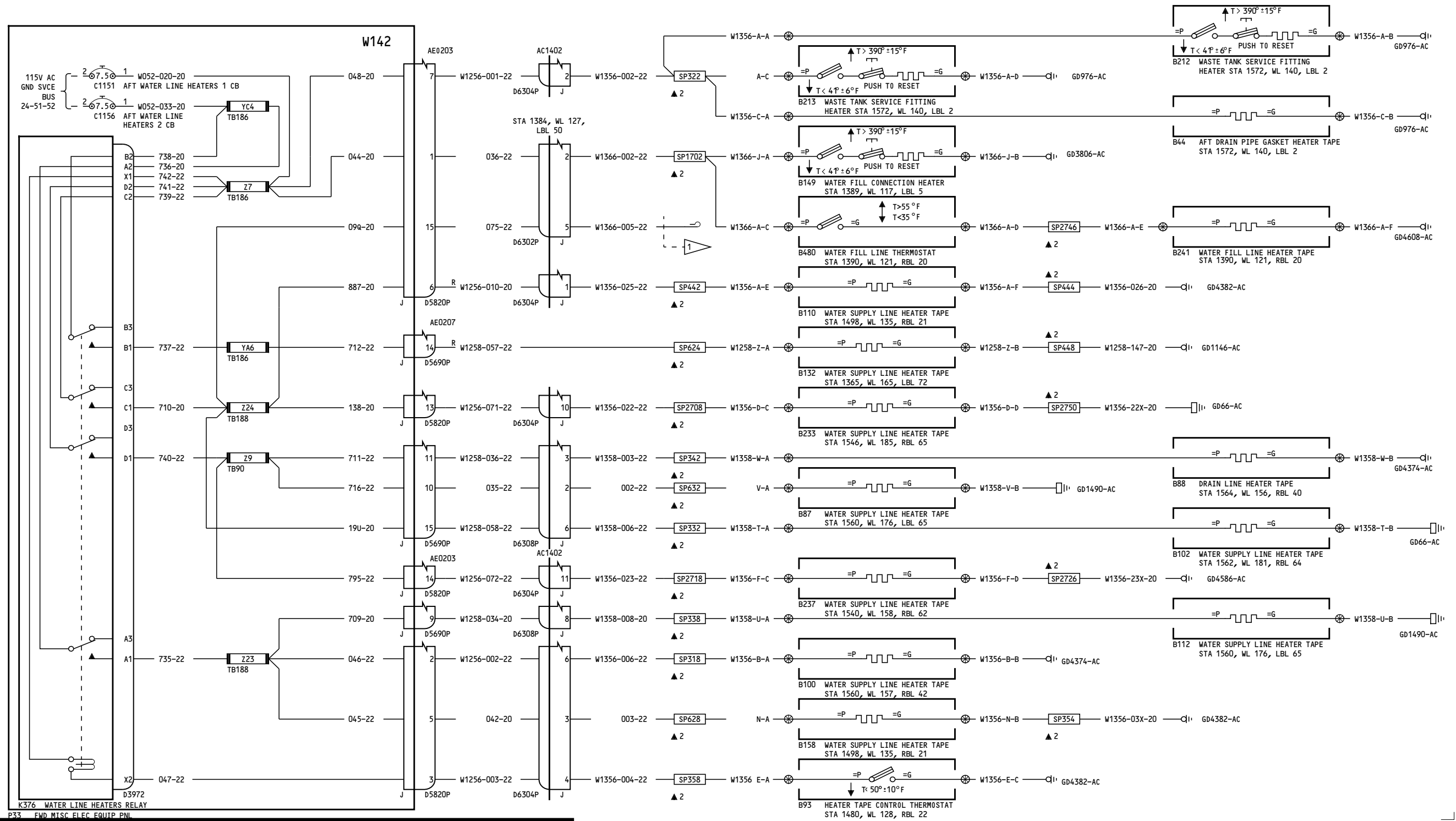

150-154

P33 FWD MISC ELEC EQUIP PNL

AFT WATER SUPPLY LINE & DRAIN LINE HEATERS

D280T132

30-71-23

Page 2.1

Jan 21/2005

Incorporates 30-0024

1 CAP & STOW NEAR SP2746

30-71-23

Page 2.1

Jan 21/2005

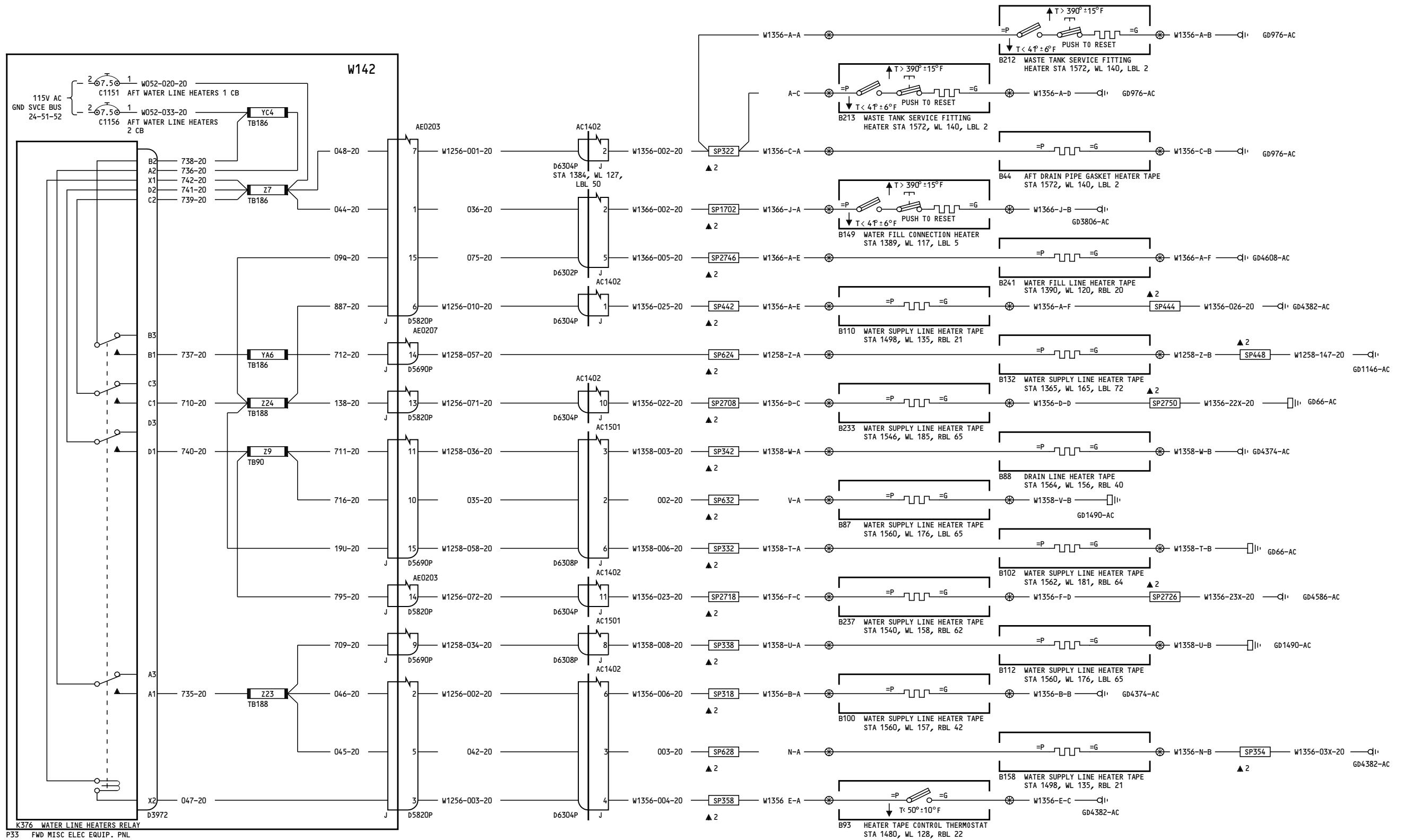

K376 WATER LINE HEATERS RELAY
P33 FWD MISC ELEC EQUIP. PNL

155-199

**AFT WATER SUPPLY LINE &
DRAIN LINE HEATERS**

30-71-23

Page 3

D280T132

Jan 21/2005

30-71-23

Page 3

Jan 21/2005

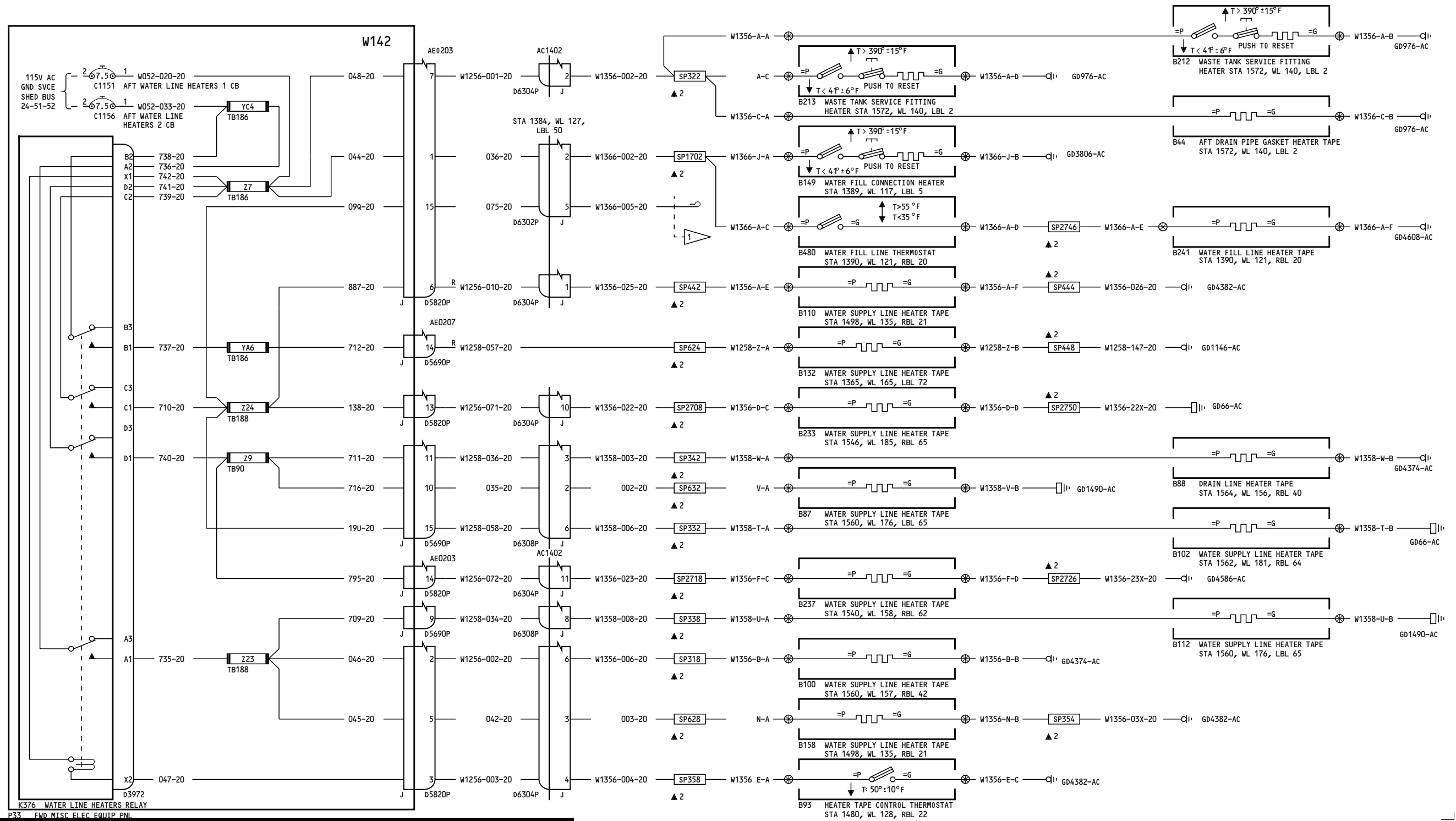

155-167
 P33 FWD MISC ELEC EQUIP PNL

AFT WATER SUPPLY LINE & DRAIN LINE HEATERS
 D280T132

30-71-23
 Page 3.1
 Jan 21/2005

Incorporates
 30-0024

1 CAP & STOW NEAR SP2746

30-71-23
 Page 3.1
 Jan 21/2005

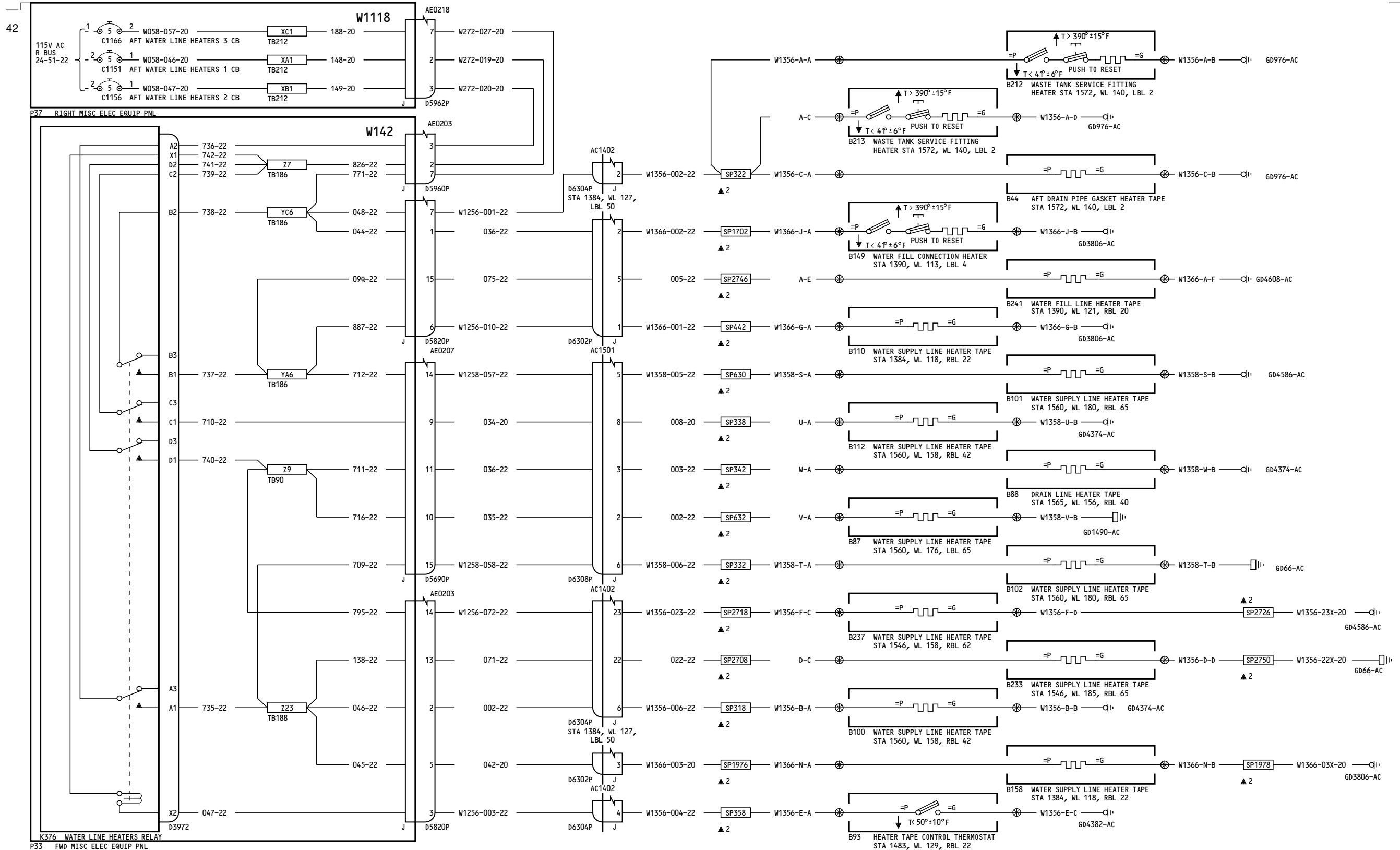

275

AFT WATER SUPPLY LINE & DRAIN LINE HEATERS

30-71-23

Page 4

Jan 21/2005

D280T132

30-71-23

Page 4

Jan 21/2005

136

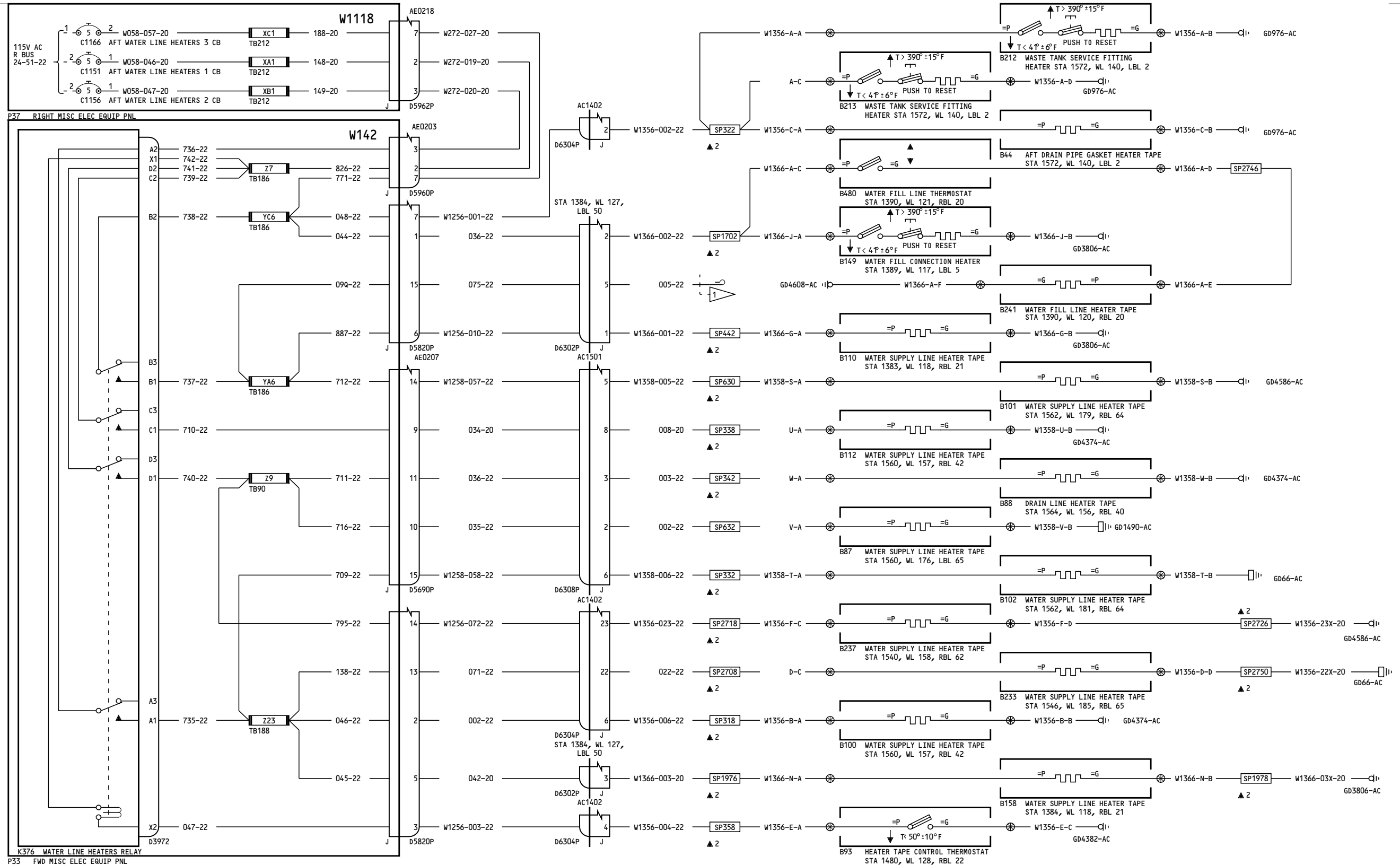

P37 RIGHT MISC ELEC EQUIP PNL
K376 WATER LINE HEATERS RELAY
P33 FWD MISC ELEC EQUIP PNL

275

AFT WATER SUPPLY LINE & DRAIN LINE HEATERS

D280T132

30-71-23

Page 4.1

Jan 21/2005

Incorporates 30-0024 & STOW NEAR SP2746

30-71-23

Page 4.1

Jan 21/2005

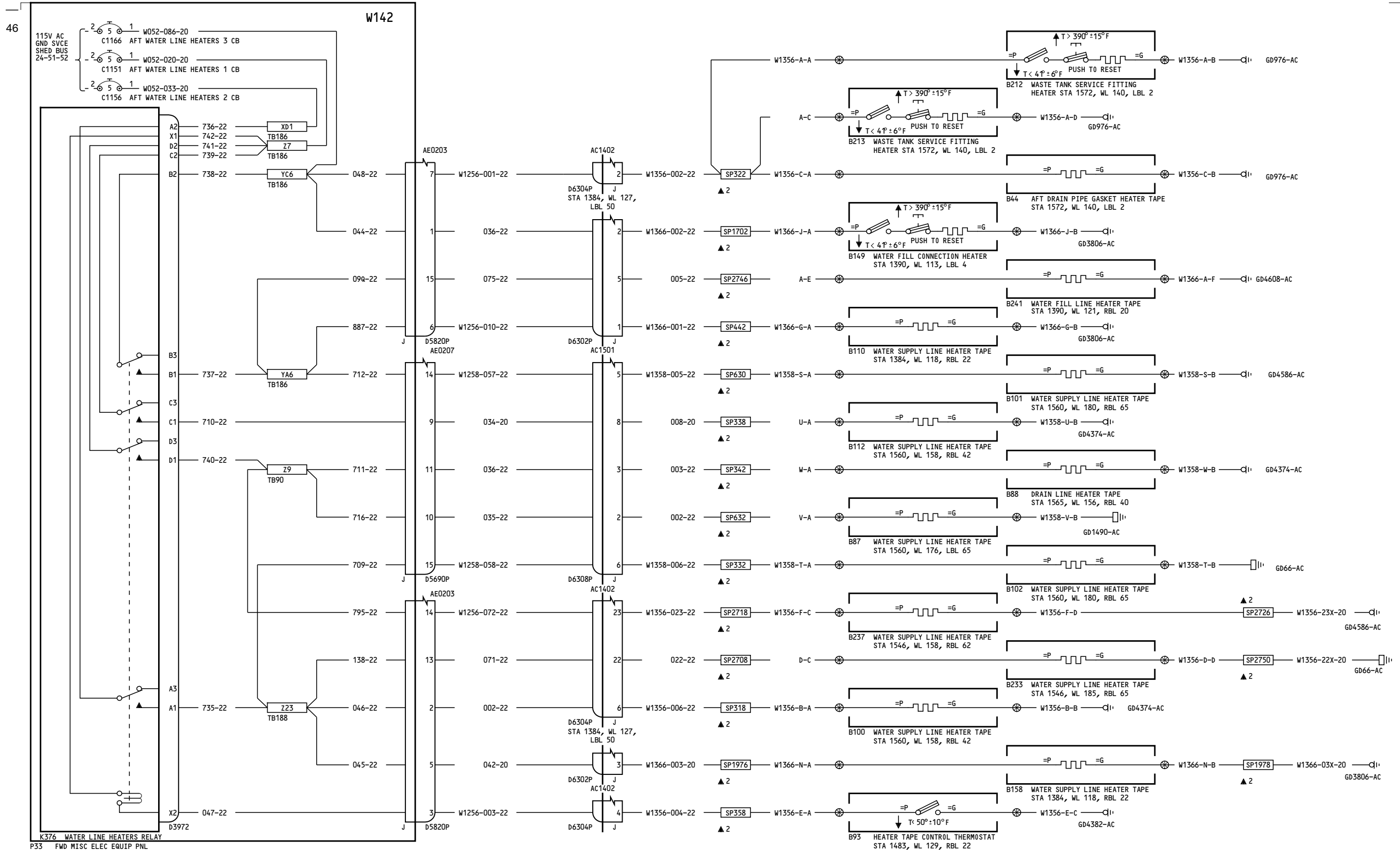

276

AFT WATER SUPPLY LINE & DRAIN LINE HEATERS

30-71-23

Page 5

D280T132

Jan 21/2005

30-71-23

Page 5

Jan 21/2005

143

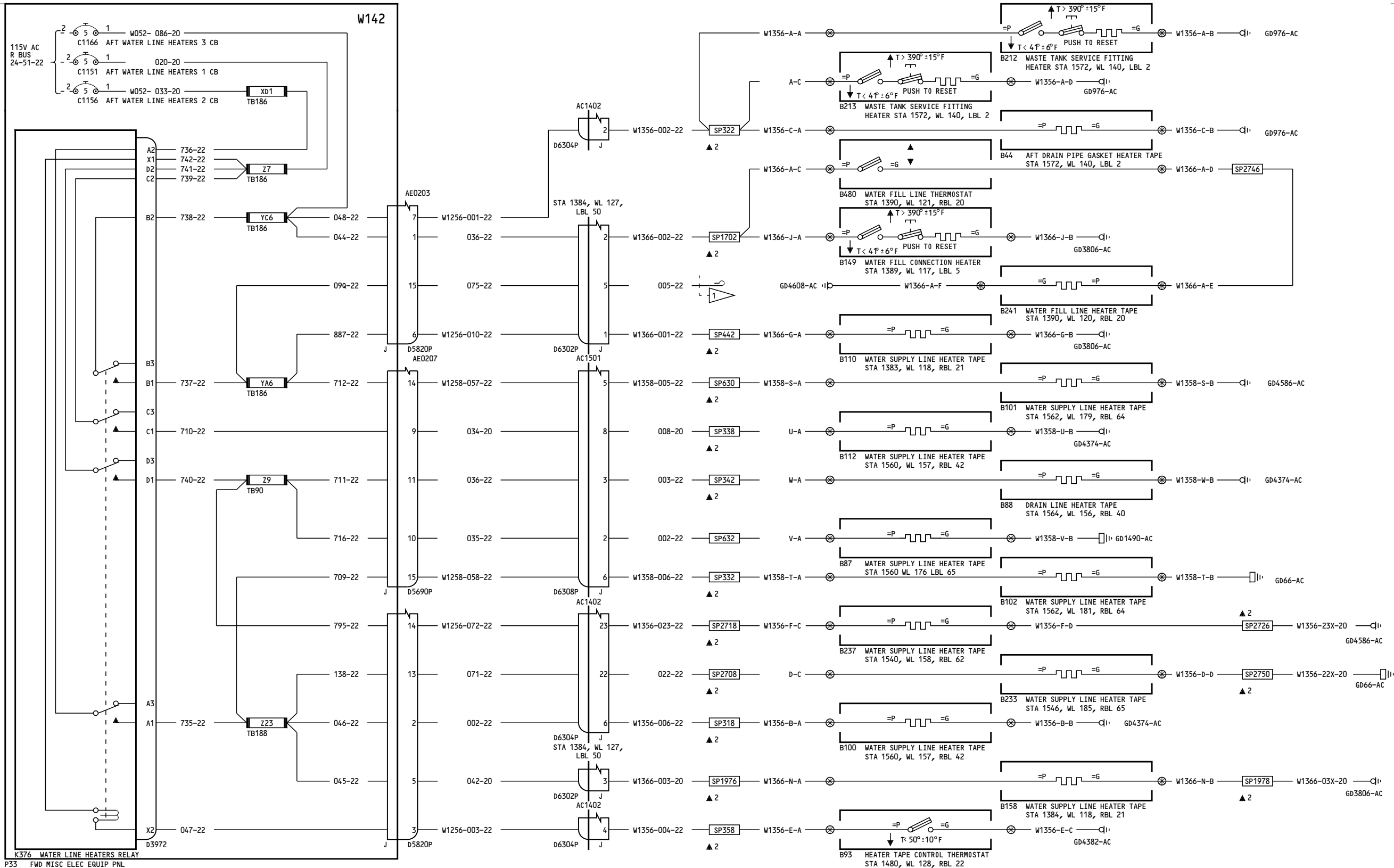

K376 WATER LINE HEATERS RELAY
P33 FWD MISC ELEC EQUIP PNL

276

AFT WATER SUPPLY LINE & DRAIN LINE HEATERS

30-71-23

Page 5.1

D280T132

Jan 21/2005

Incorporates 30-0024
SP & STOW NEAR SP2746

30-71-23

Page 5.1

Jan 21/2005

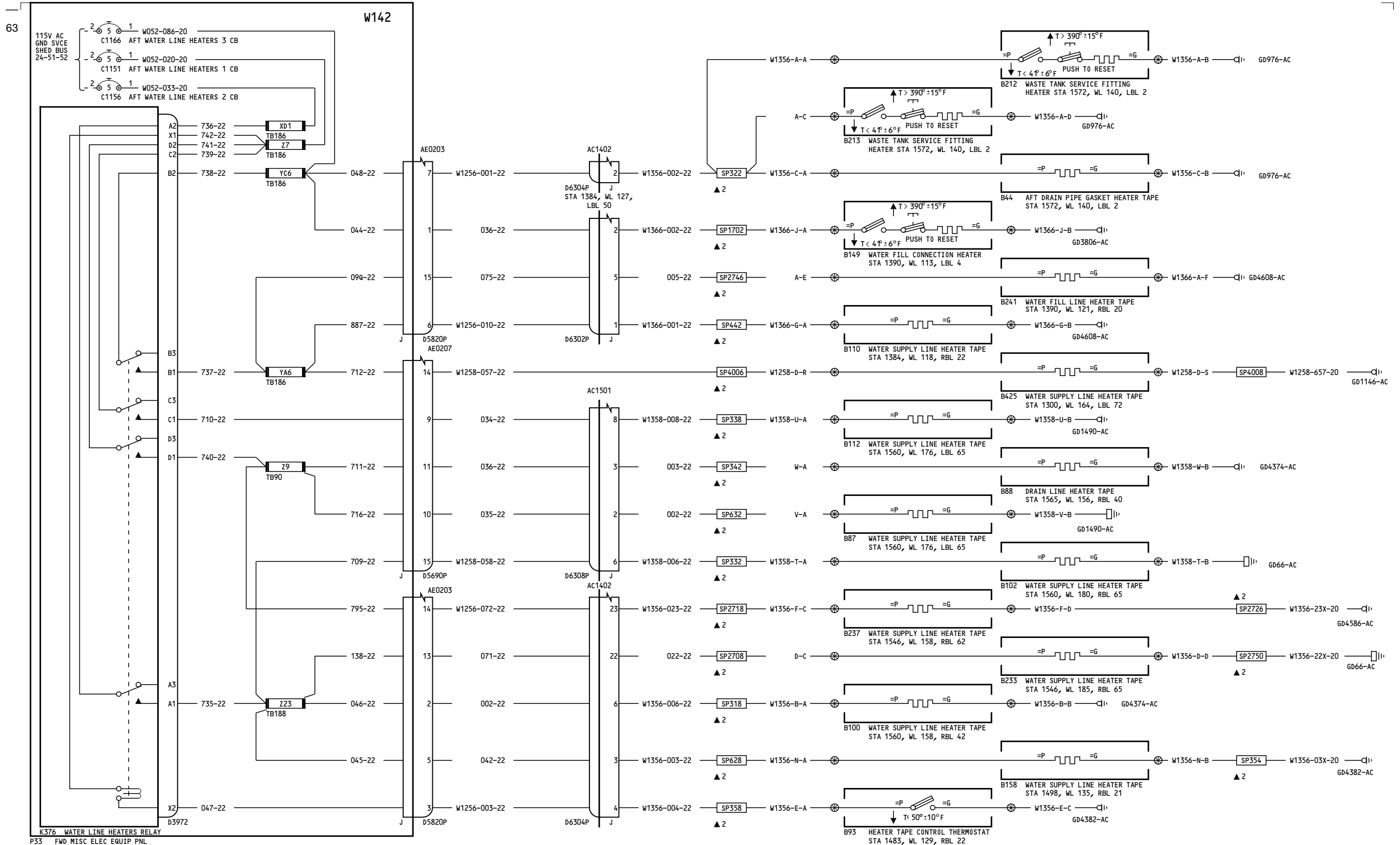

277-278

AFT WATER SUPPLY LINE & DRAIN LINE HEATERS

30-71-23

Page 6

D280T132

Jan 21/2005

30-71-23

Page 6

Jan 21/2005

139

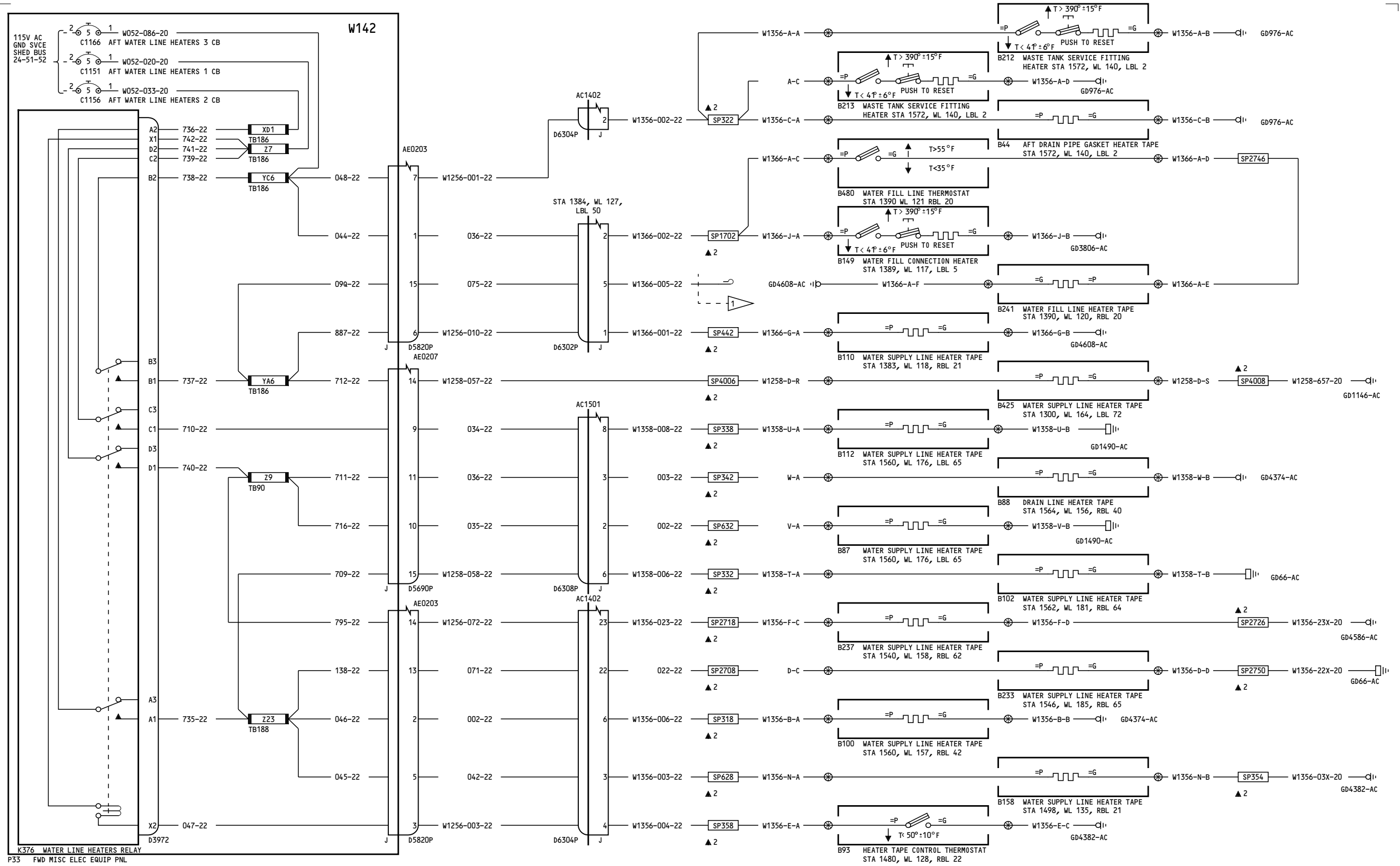

277-278

AFT WATER SUPPLY LINE & DRAIN LINE HEATERS

D280T132

30-71-23

Page 6.1

Jan 21/2005

Incorporates CAP & STOW NEAR SP2746
30-0024

30-71-23

Page 6.1

Jan 21/2005

52

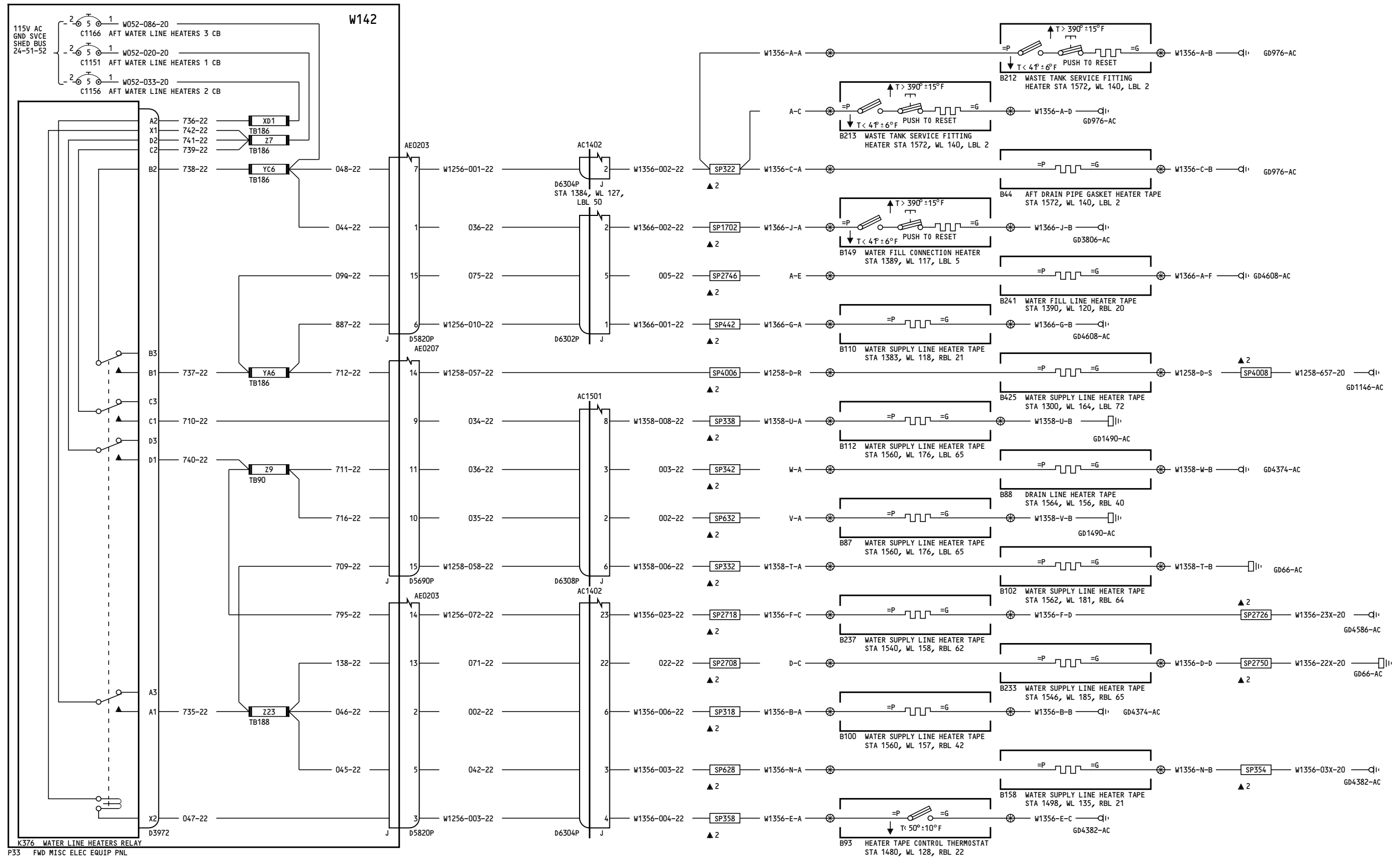

K376 WATER LINE HEATERS RELAY
P33 FWD MISC ELEC EQUIP PNL

280-299

AFT WATER SUPPLY LINE & DRAIN LINE HEATERS

30-71-23

Page 7

D280T132

Jan 21/2005

30-71-23

Page 7

Jan 21/2005

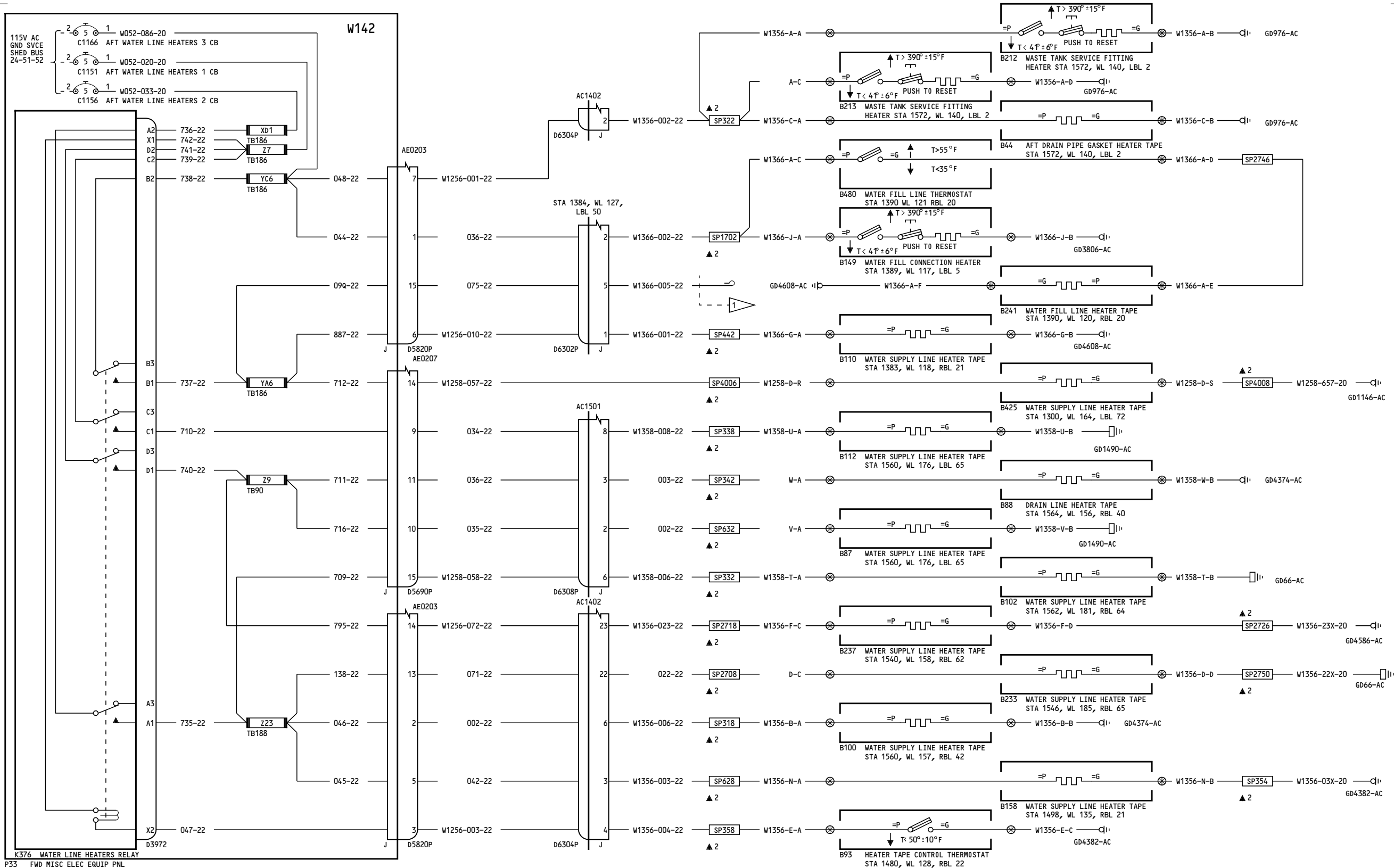

K376 WATER LINE HEATERS RELAY
 P33 FWD MISC ELEC EQUIP PNL

280

AFT WATER SUPPLY LINE & DRAIN LINE HEATERS

D280T132

30-71-23

Page 7.1

Jan 21/2005

Incorporates CAP & STOW NEAR SP2746
 30-0024

30-71-23

Page 7.1

Jan 21/2005

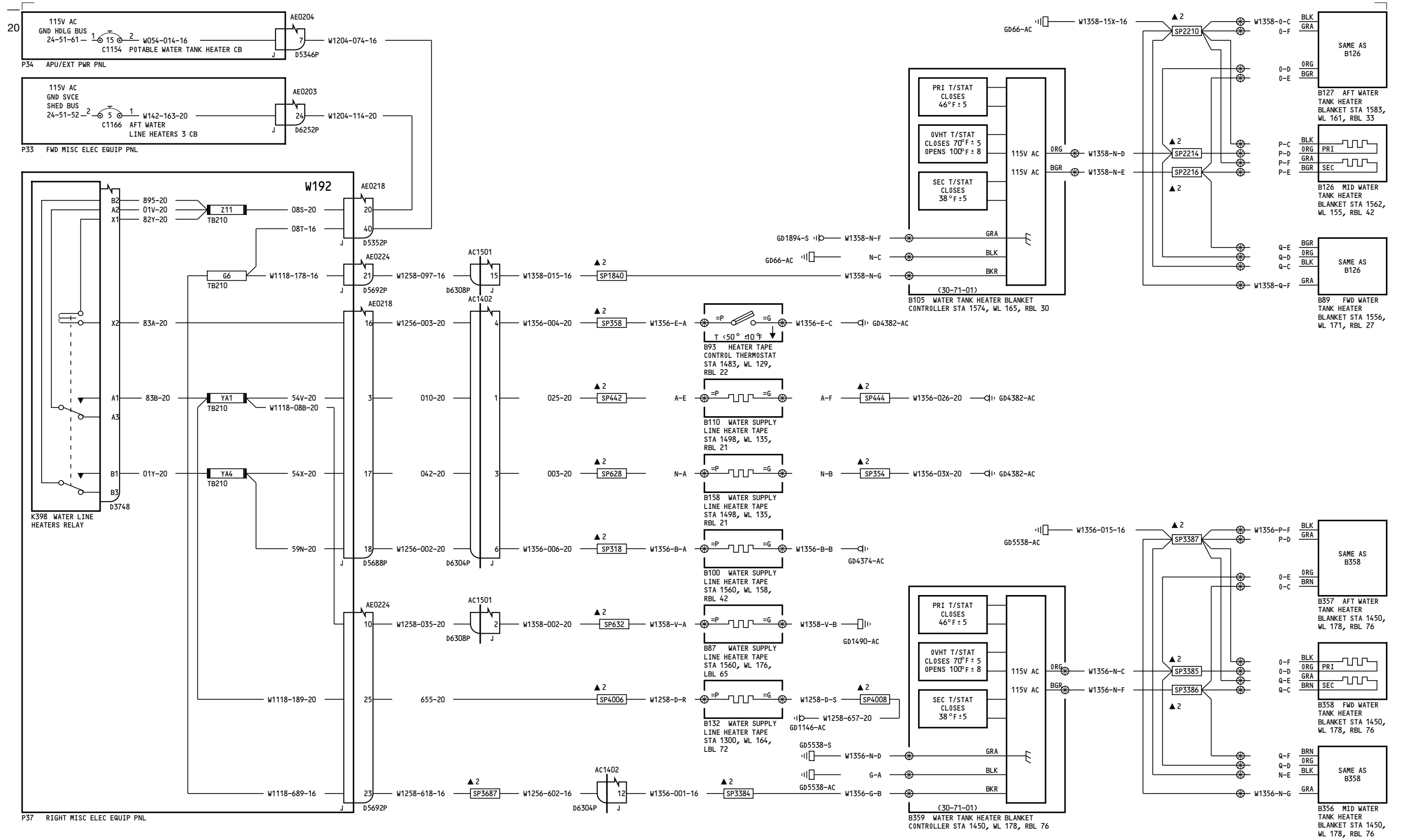

050

AFT WATER SUPPLY LINE & WATER TANK HEATERS

30-71-24

Page 1

Jan 21/2005

D280T132

30-71-24

Page 1

Jan 21/2005

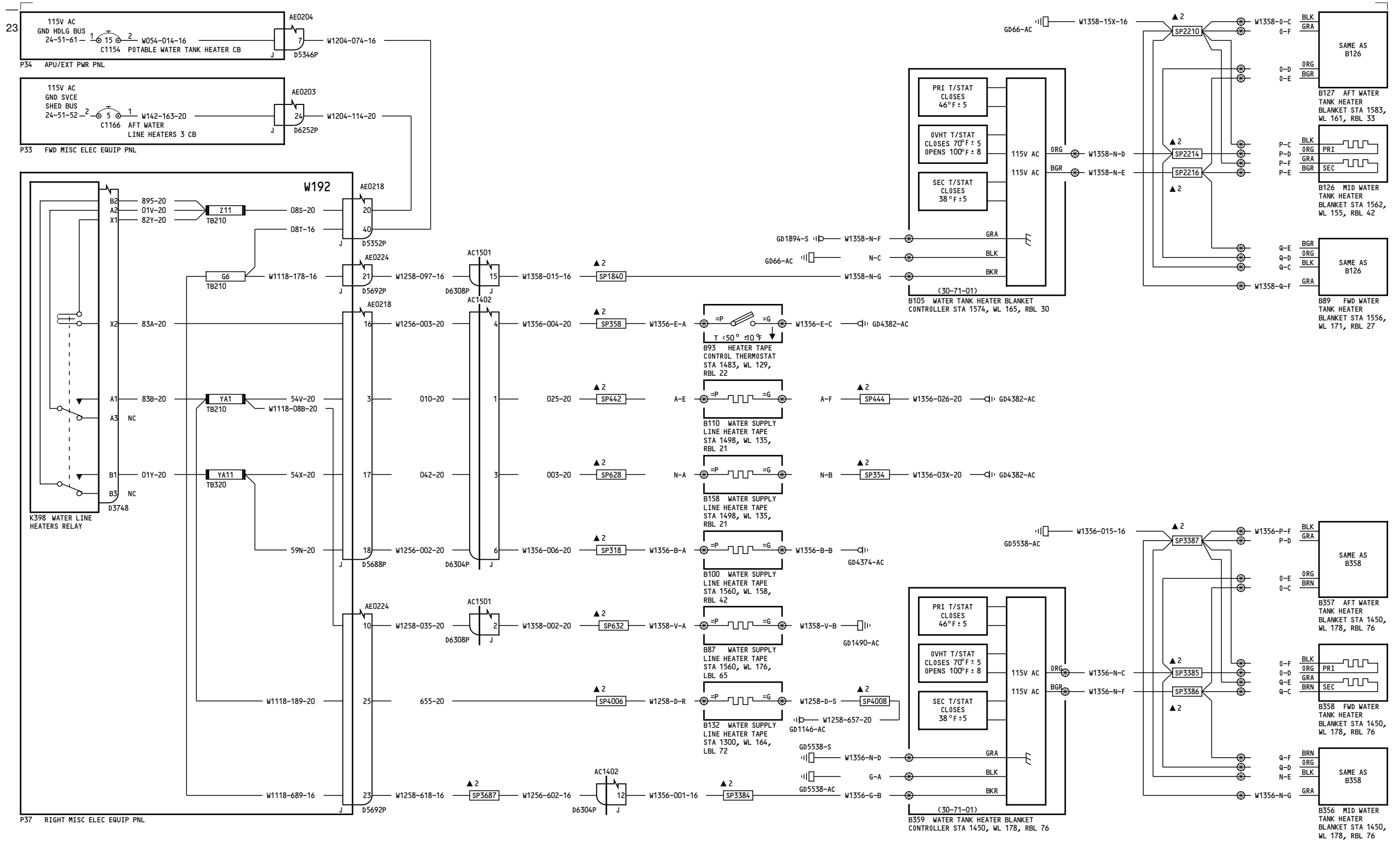

051-099

AFT WATER SUPPLY LINE & WATER TANK HEATERS

30-71-24

Page 2

D280T132

30-71-24

Page 2

Jan 21/2005

30-71-24

Page 2

Jan 21/2005

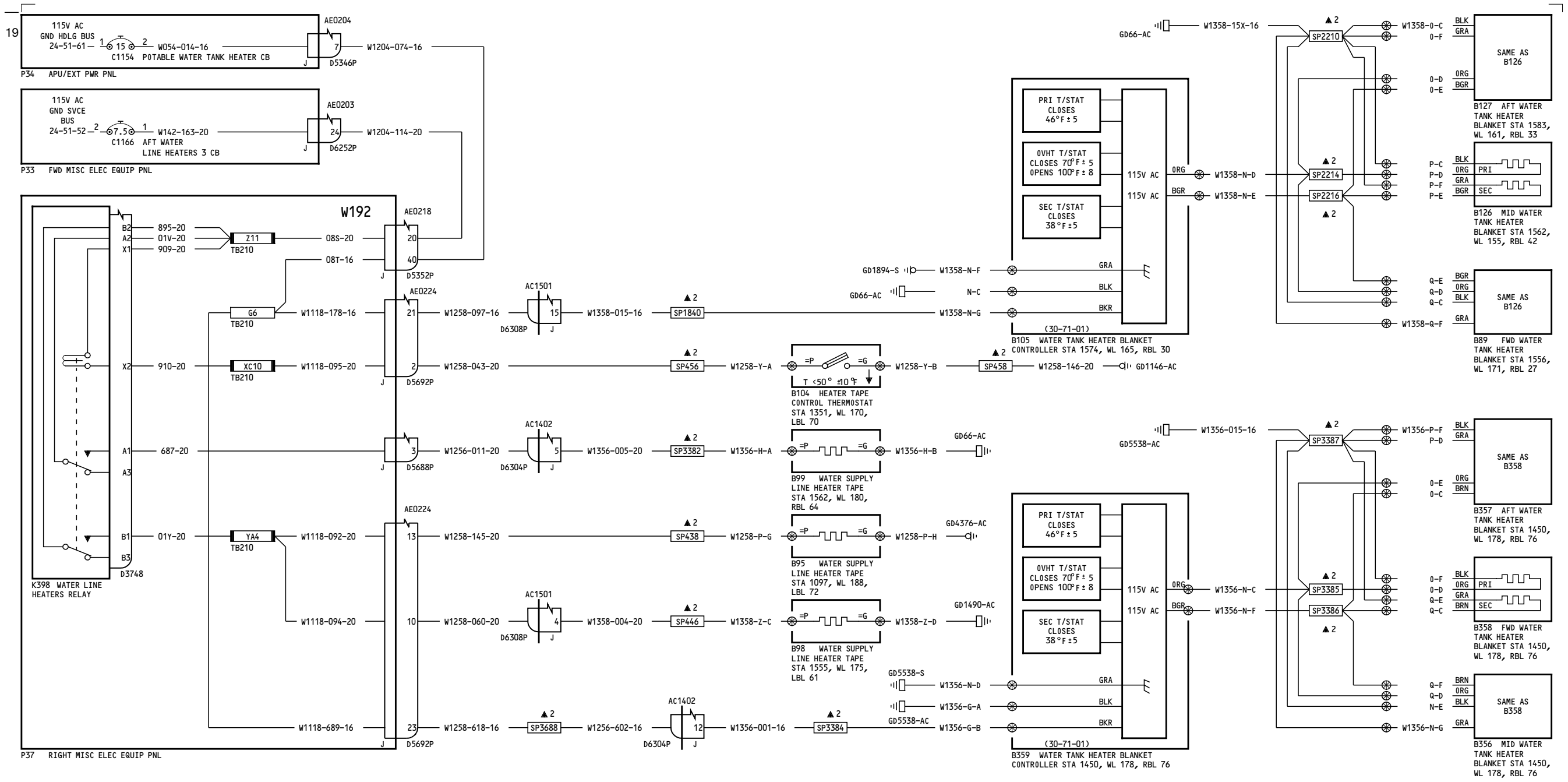

150-154

AFT WATER SUPPLY LINE & WATER TANK HEATERS

30-71-24

Page 3

D280T132

Jan 21/2005

30-71-24

Page 3

Jan 21/2005

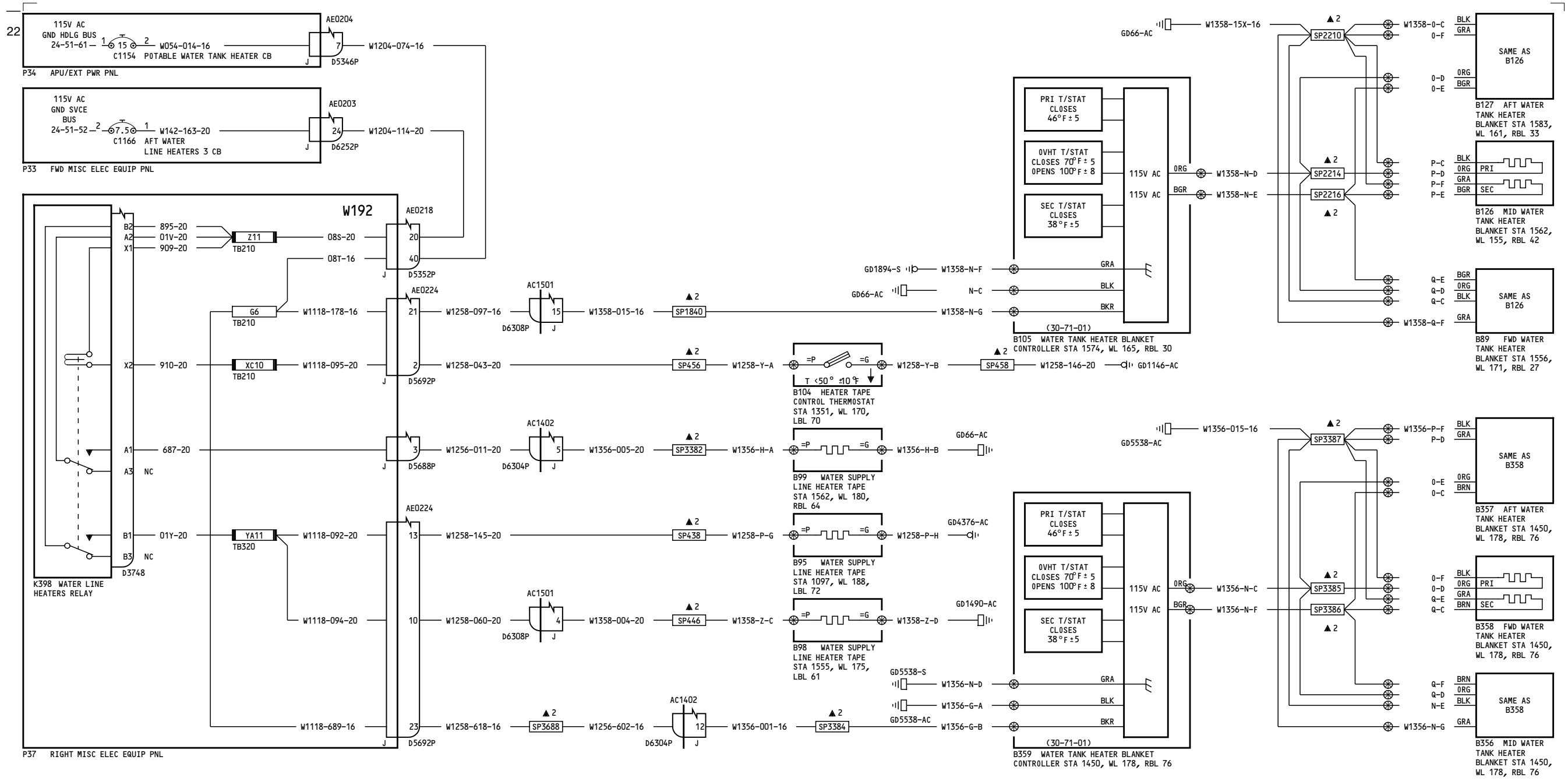

155-199

AFT WATER SUPPLY LINE & WATER TANK HEATERS

30-71-24

Page 4

D280T132

Jan 21/2005

30-71-24

Page 4

Jan 21/2005

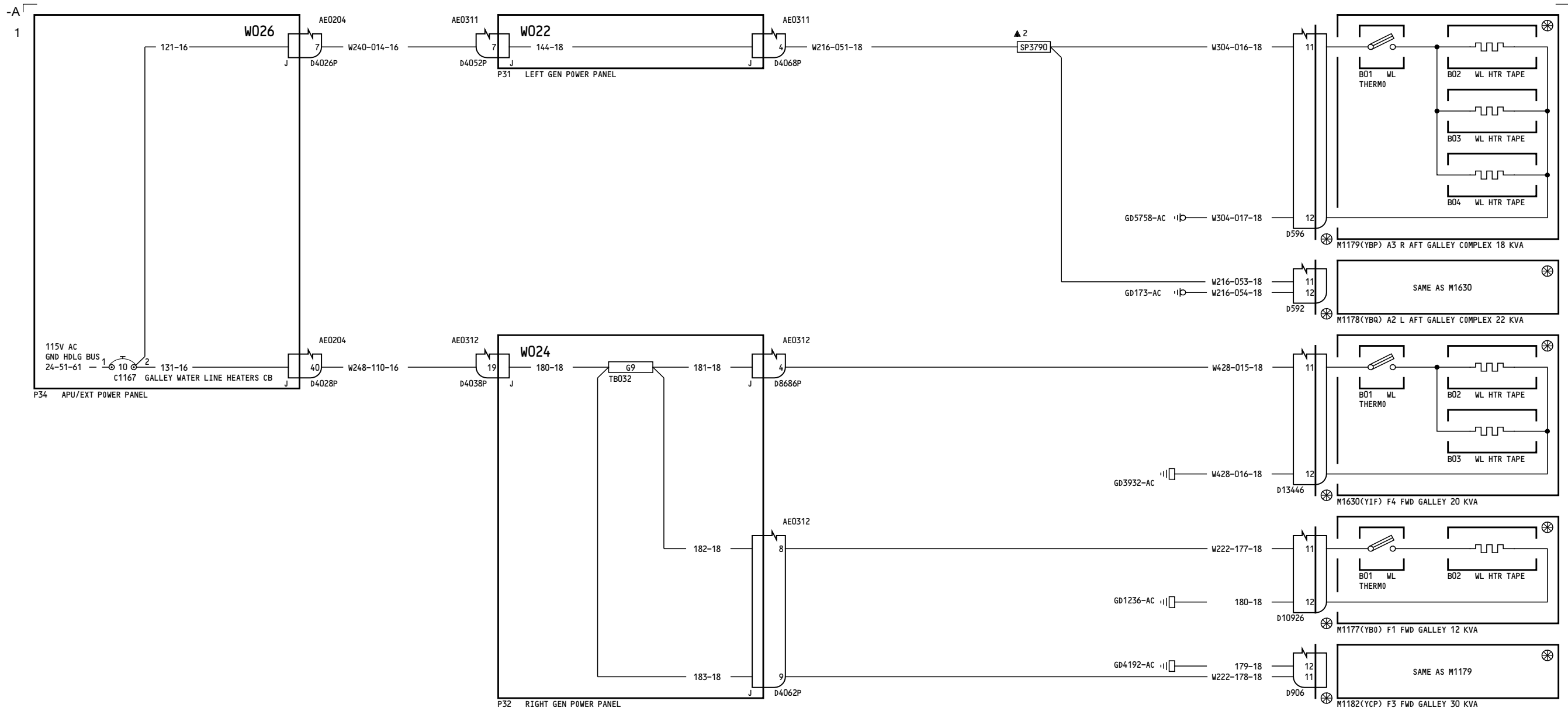

050-099, 150-199

**GALLEY WATER SUPPLY
LINE & SUPPLY LINE
HEATERS**

D280T132

30-71-25

Page 1

Jan 21/2005

30-71-25

Page 1

Jan 21/2005

-A
2

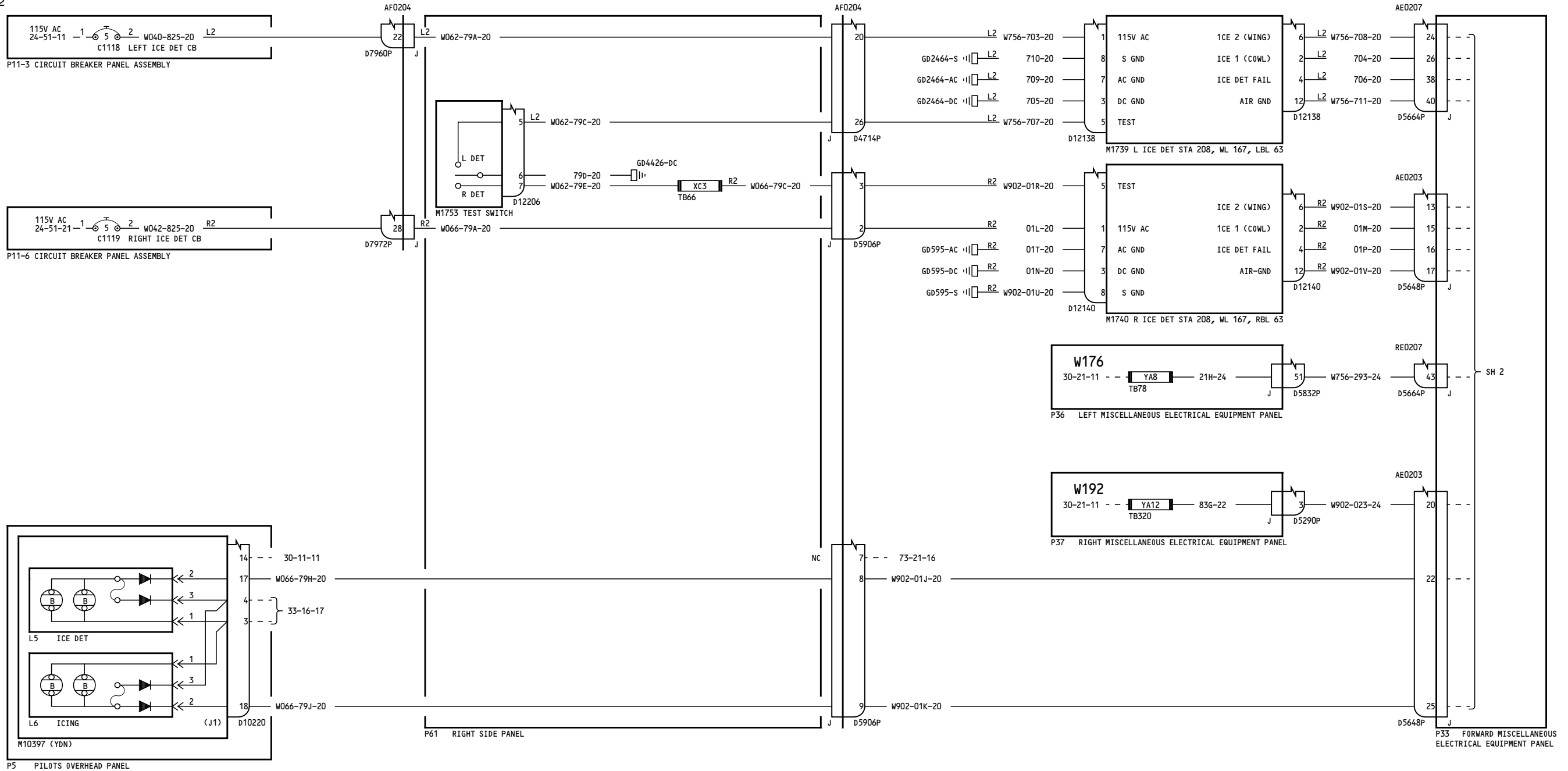

050, 155-167

AUTOMATIC-ICE DETECTOR

30-81-11

Page 1.1
Sheet 1
Jan 21/2005

D280T132

30-81-11

Page 1.1
Sheet 1
Jan 21/2005

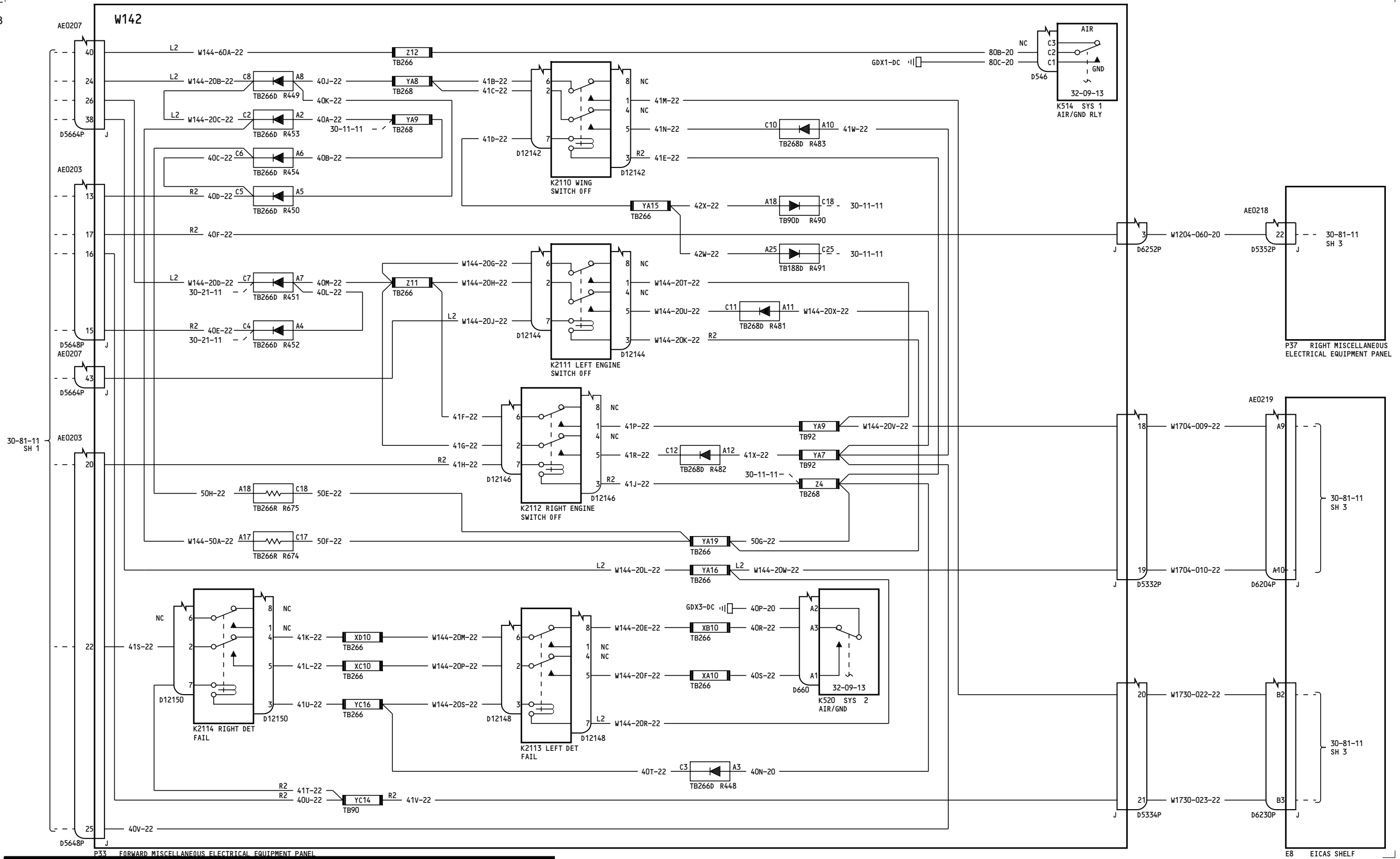

050, 155-167

AUTOMATIC-ICE DETECTOR

30-81-11

Page 1.1
Sheet 2
Jan 21/2005

D280T132

Incorporates
27A0160

30-81-11

Page 1.1
Sheet 2
Jan 21/2005

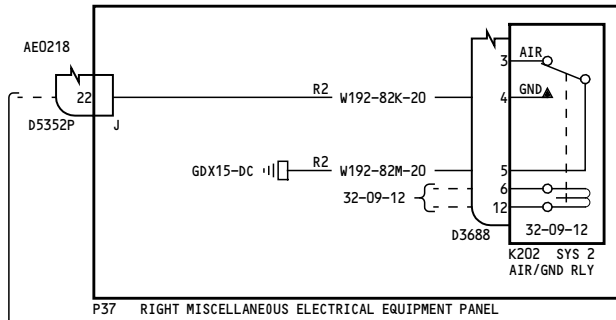

P37 RIGHT MISCELLANEOUS ELECTRICAL EQUIPMENT PANEL

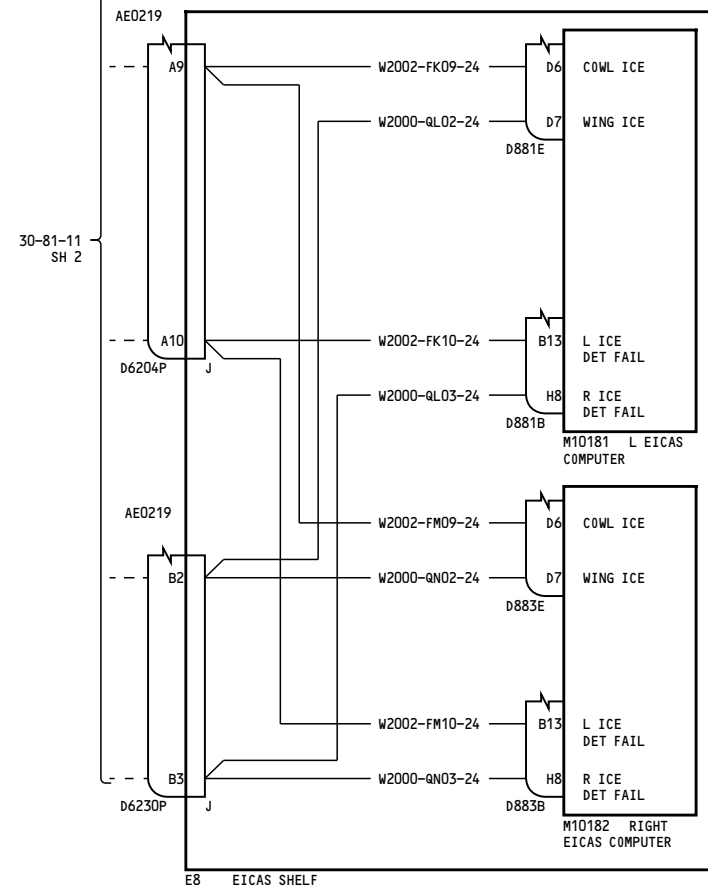

E8 EICAS SHELF

050, 155-167

AUTOMATIC-ICE DETECTOR

30-81-11

Page 1.1
Sheet 3
Jan 21/2005

D280T132

Incorporates
27A0160

30-81-11

Page 1.1
Sheet 3
Jan 21/2005

-A
2

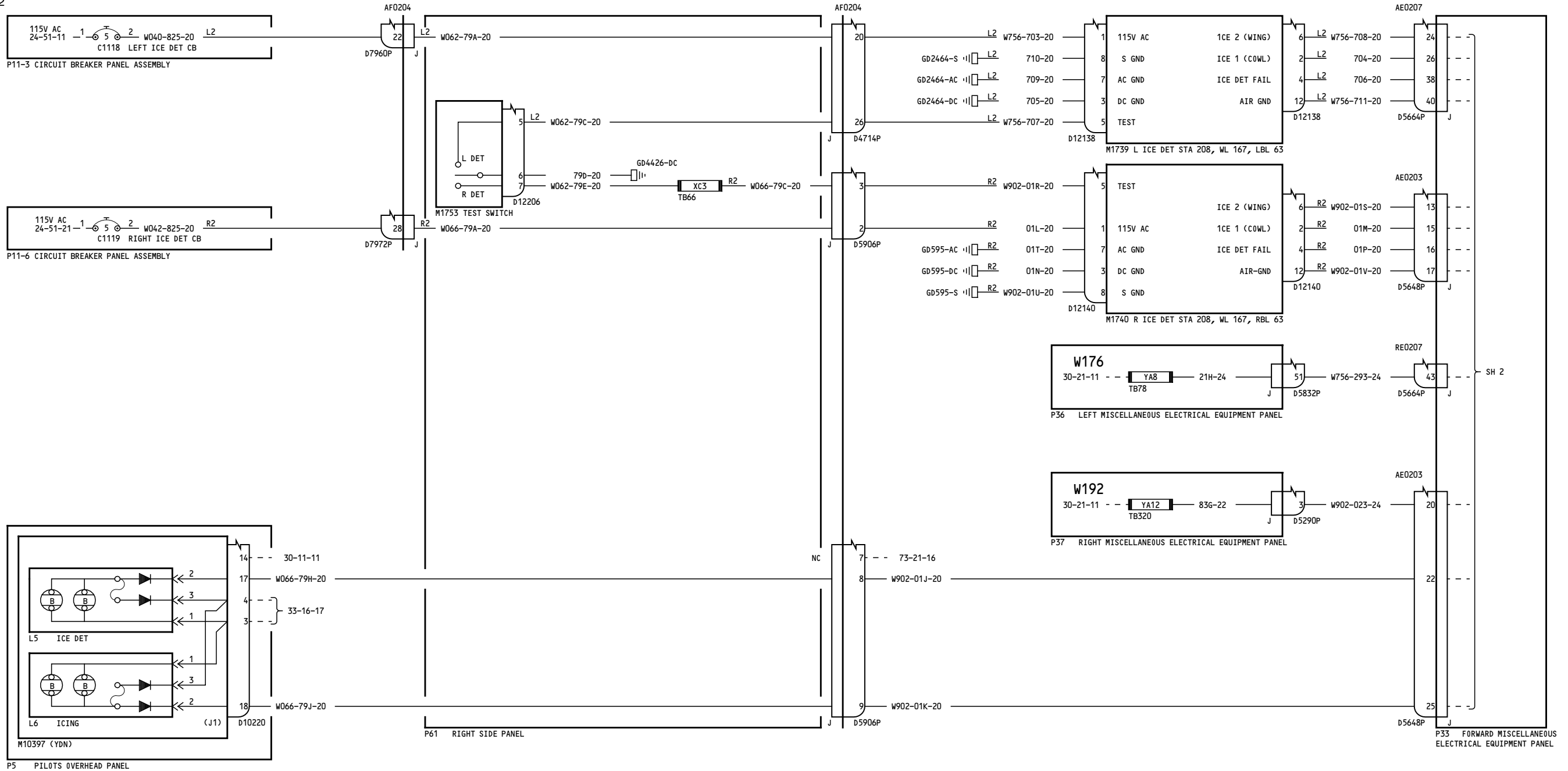

051-099	<p align="center">AUTOMATIC-ICE DETECTOR</p> <p align="center">30-81-11</p> <p align="center">D280T132</p>
---------	--

30-81-11

Page 2
Sheet 1
Jan 21/2005

30-81-11

Page 2
Sheet 1
Jan 21/2005

-A
2

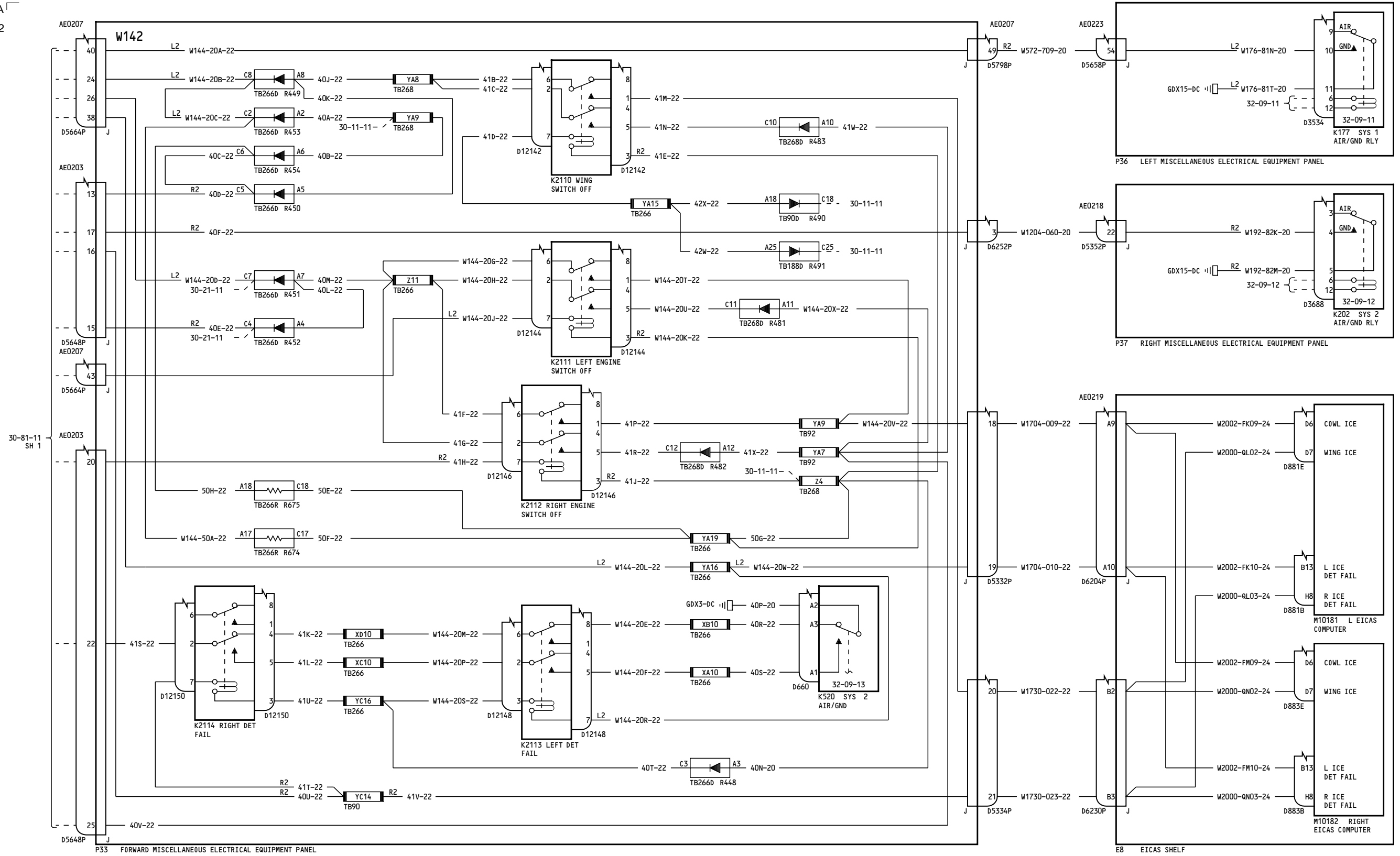

051-099

AUTOMATIC-ICE DETECTOR

30-81-11

Page 2
Sheet 2
Jan 21/2005

D280T132

30-81-11

Page 2
Sheet 2
Jan 21/2005

12

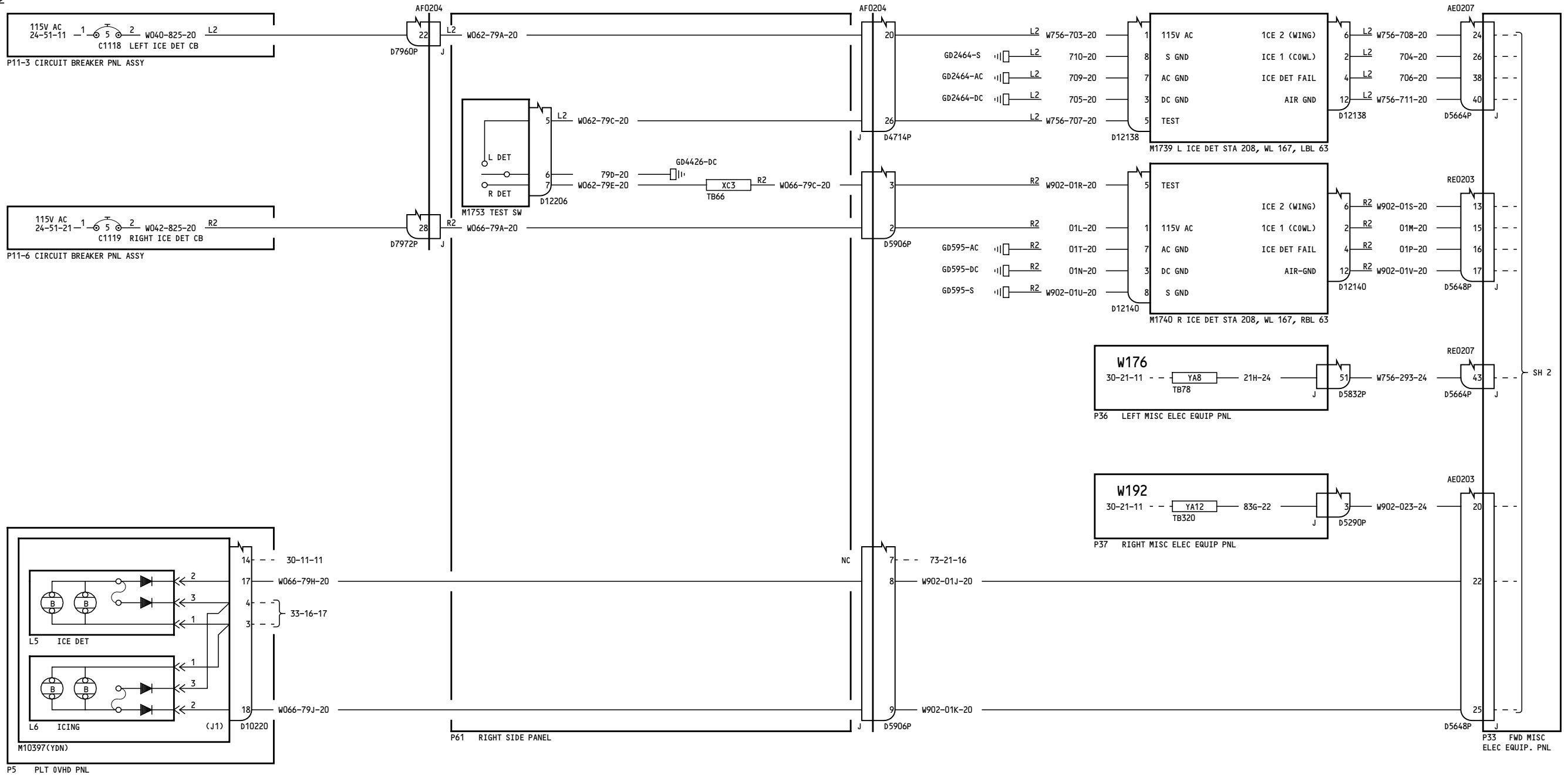

150, 152-154	<p>AUTOMATIC-ICE DETECTOR</p> <p>30-81-11</p> <p>Page 3.1 Sheet 1 Jan 21/2005</p> <p>D280T132</p>
--------------	---

Incorporates
▶ 30-0017

30-81-11

Page 3.1
Sheet 1
Jan 21/2005

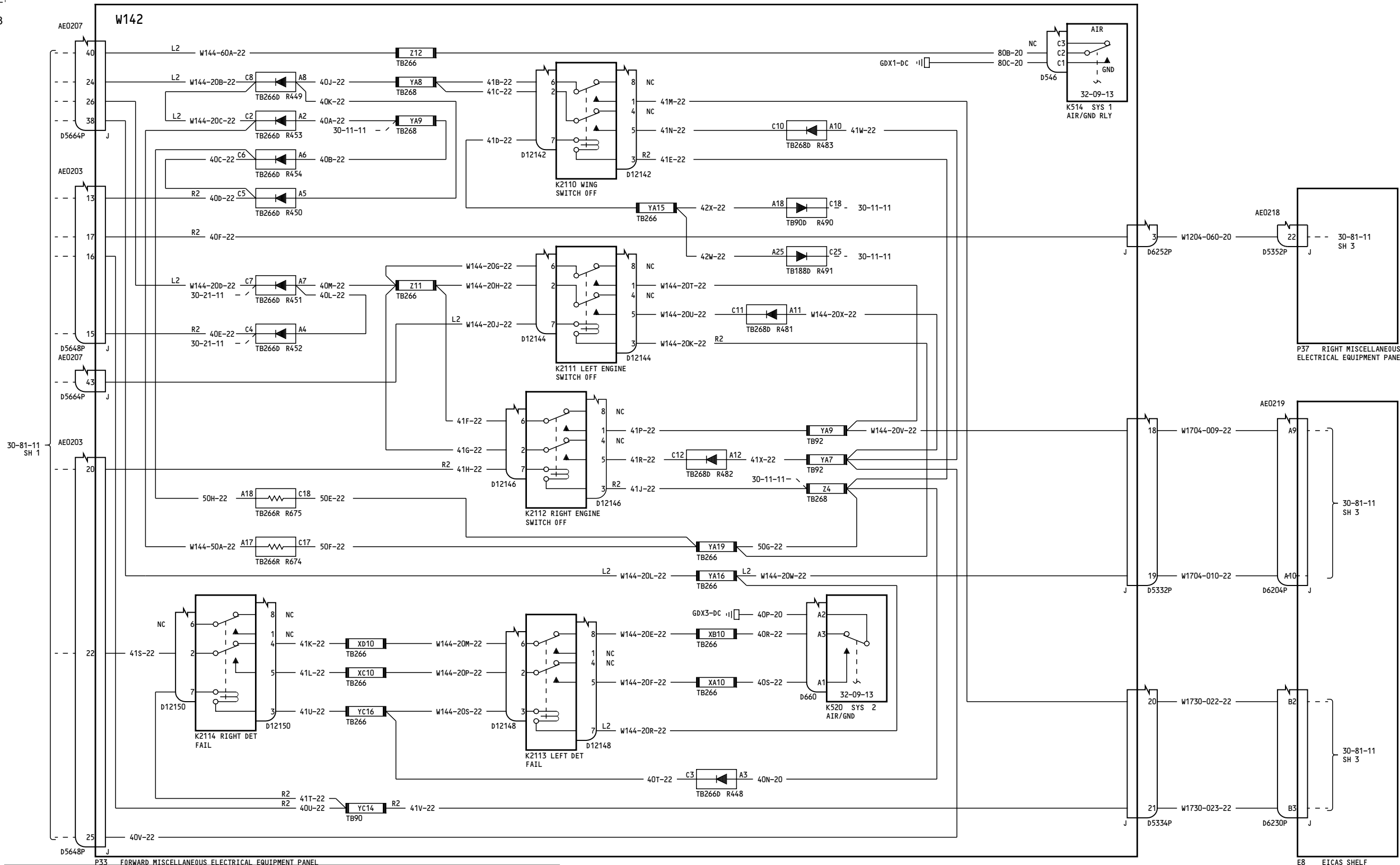

150, 152-154

AUTOMATIC-ICE DETECTOR

D280T132

30-81-11

Page 3.1
Sheet 2
Jan 21/2005

30-81-11

Page 3.1
Sheet 2
Jan 21/2005

Incorporates
 27A0160
 30-0017

BOEING PROPRIETARY - Copyright © - Unpublished Work - See title page for details.

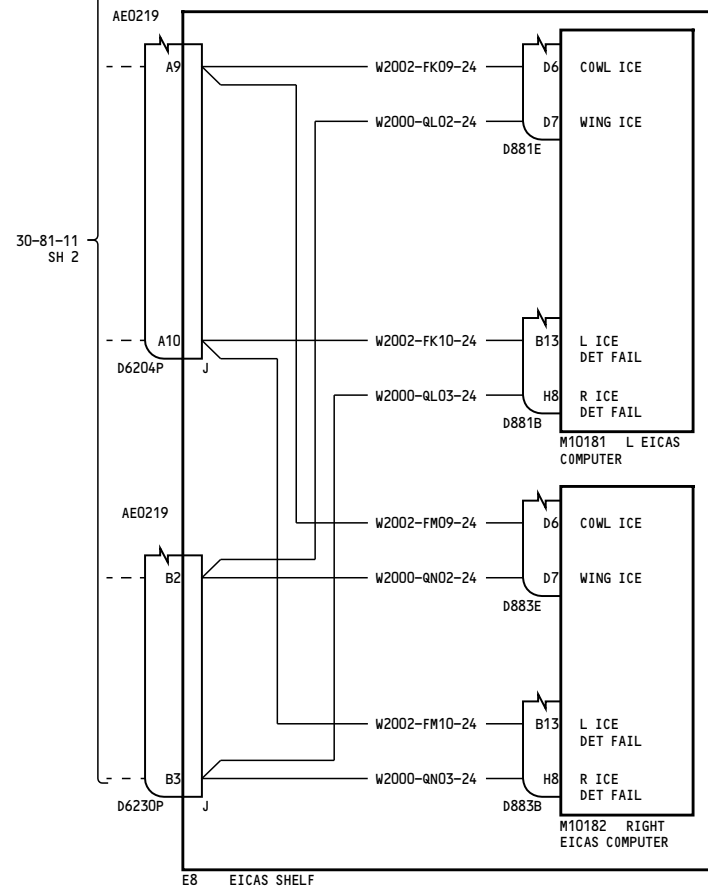
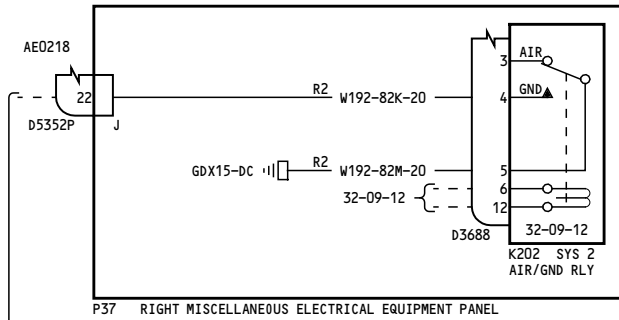

150, 152-154

AUTOMATIC-ICE DETECTOR

30-81-11

Page 3.1
Sheet 3
Jan 21/2005

D280T132

Incorporates
27A0160

30-81-11

Page 3.1
Sheet 3
Jan 21/2005

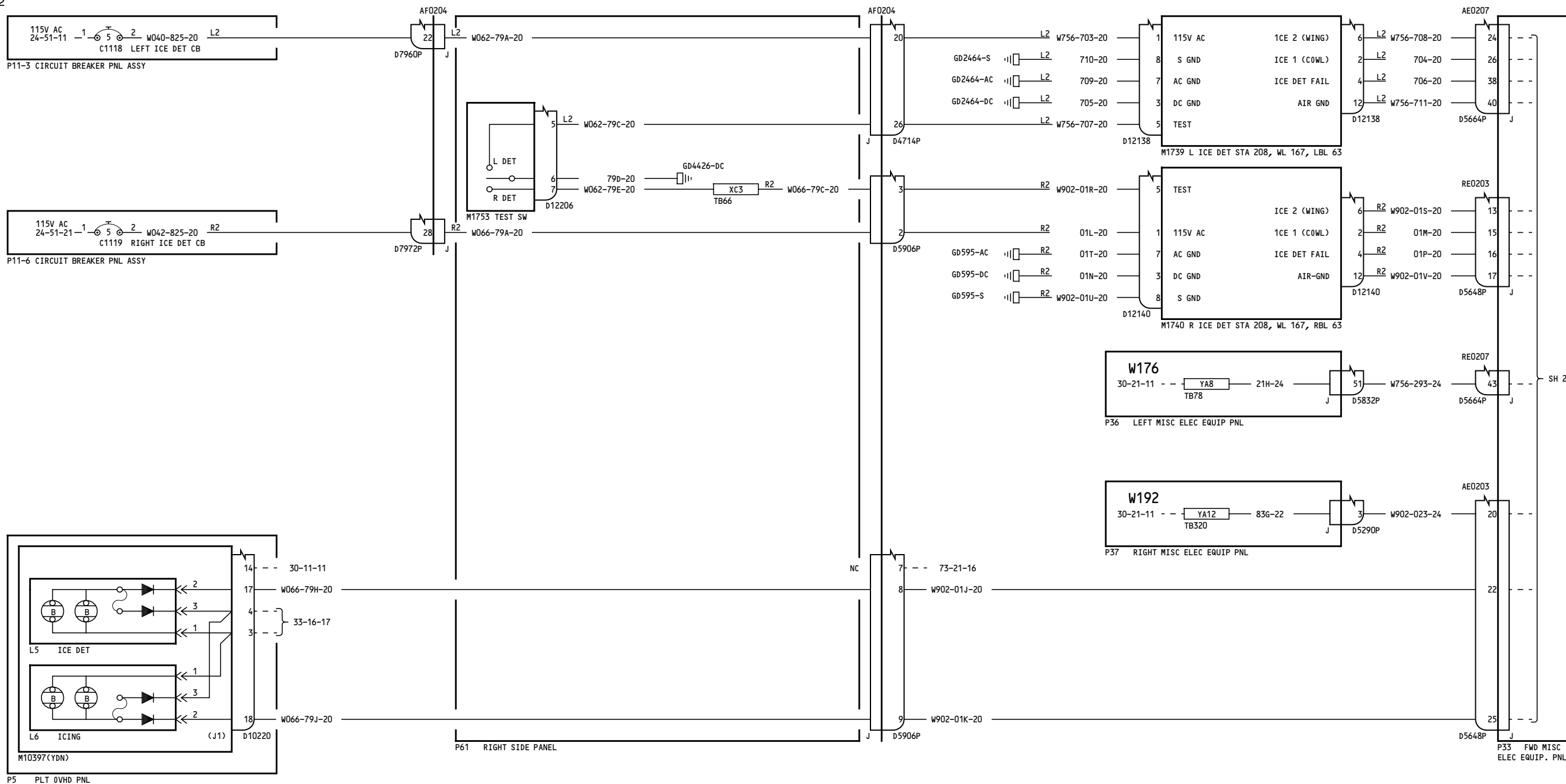

12

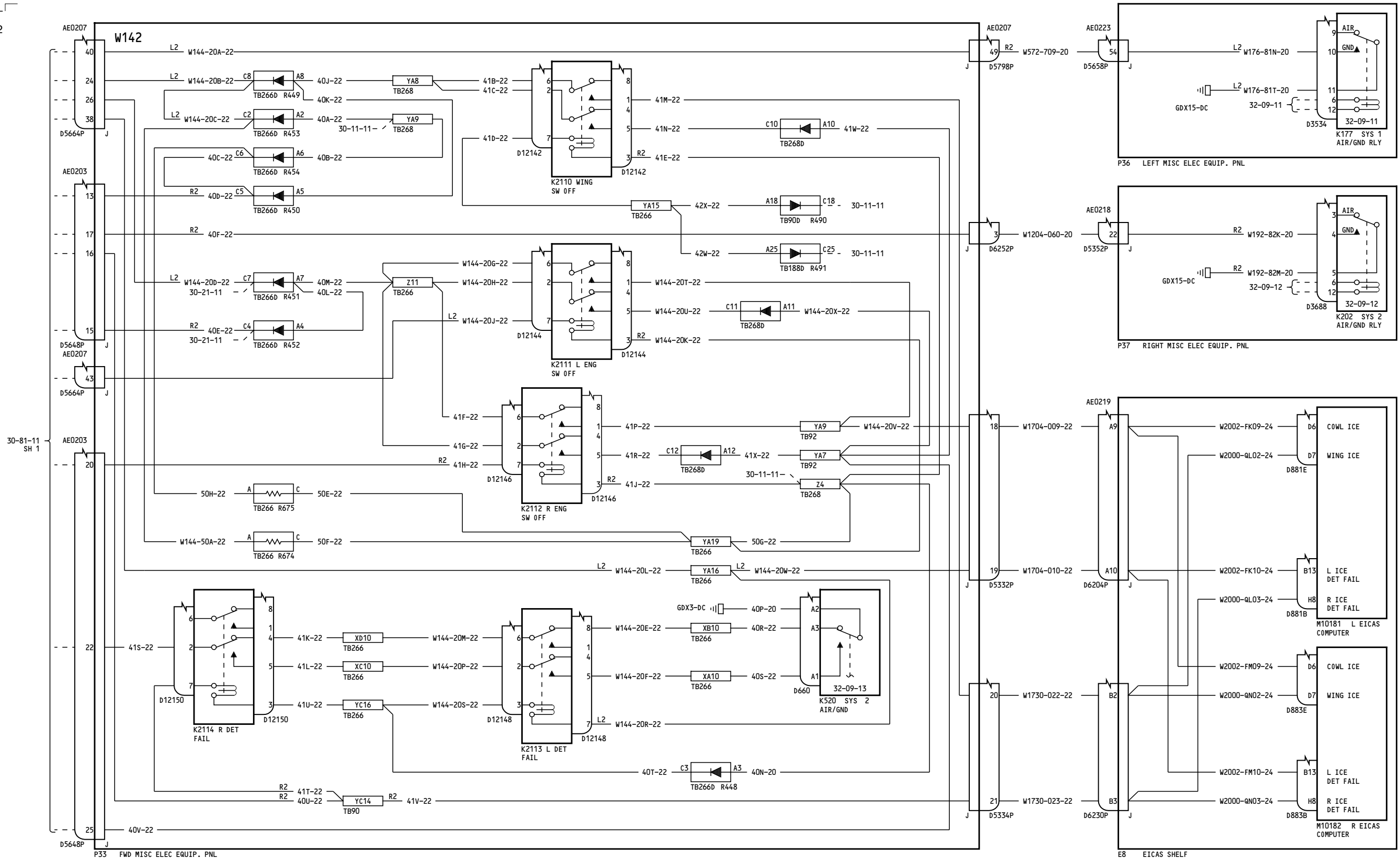

151

AUTOMATIC-ICE DETECTOR

30-81-11

Page 4.1
Sheet 2
Jan 21/2005

D280T132

Incorporates
30-0017

30-81-11

Page 4.1
Sheet 2
Jan 21/2005