

**CHAPTER**

**32**

**LANDING GEAR**



767-200/300

WIRING DIAGRAM MANUAL

CHAPTER 32  
LANDING GEAR

CH-SC-SU	Schem	Page	Sheet	Date	CH-SC-SU	Schem	Page	Sheet	Date
32-EFFECTIVE PAGES					32-09-12 (cont.)				
		1 thru 2		Aug 05/2009			2.1	1	Jan 21/2005
32-CONTENTS								2	Jan 21/2005
		1		Jun 28/2006			3.1	1	Jan 21/2005
		2		Jun 28/2006				2	Jan 21/2005
		3		Mar 14/2007			4.1	1	Jan 21/2005
		4		Mar 14/2007				2	Jan 21/2005
		5		Mar 14/2007			5.1	1	Jan 21/2005
		6		BLANK				2	Jan 21/2005
32-ALPHABETICAL INDEX							6.1	1	Jan 21/2005
		1		Jan 21/2005				2	Jan 21/2005
		2		BLANK			7.1	1	Jan 21/2005
32-09-11								2	Jan 21/2005
		1.1	1	Jan 21/2005	32-09-13				
			2	Jan 21/2005			1.1		Mar 09/2006
			3	Jan 21/2005			2.1		Mar 09/2006
		2	1	Jan 21/2005			3.1		Mar 09/2006
			2	Jan 21/2005			4.1		Mar 09/2006
			3	Jan 21/2005			5.1		Mar 09/2006
		2.1A	1	Jan 21/2005			6.1		Mar 09/2006
			2	Jan 21/2005	32-09-21				
			3	Jan 21/2005			1		Jan 21/2005
		2.2	1	Jan 21/2005			2		Jan 21/2005
			2	Jan 21/2005			2.1		Jan 21/2005
			3	Jan 21/2005			3		Jan 21/2005
		2.3B	1	Jan 21/2005	32-31-11				
			2	Jan 21/2005			1		Jan 21/2005
			3	Jan 21/2005	32-35-11				
		3.1A	1	Jan 21/2005			1		Jan 21/2005
			2	Jan 21/2005	32-41-11				
			3	Jan 21/2005			1		Jan 21/2005
		4.1A	1	Jan 21/2005			2		Jan 21/2005
			2	Jan 21/2005	32-42-11				
			3	Jan 21/2005			1	1	Jan 21/2005
		5.1A	1	Jan 21/2005				2	Jan 21/2005
			2	Jan 21/2005				3	Jan 21/2005
			3	Jan 21/2005				4	Jan 21/2005
		6.1	1	Jan 21/2005				5	Jan 21/2005
			2	Jan 21/2005			2.1	1	Jan 21/2005
			3	Jan 21/2005				2	Jan 21/2005
		7.1	1	Jan 21/2005				3	Jan 21/2005
			2	Jan 21/2005				4	Jan 21/2005
			3	Jan 21/2005				5	Jan 21/2005
		8.1	1	Jan 21/2005			3	1	Mar 14/2007
			2	Jan 21/2005				2	Mar 14/2007
			3	Jan 21/2005				3	Mar 14/2007
		9.1	1	Jan 21/2005				4	Mar 14/2007
			2	Jan 21/2005				5	Mar 14/2007
			3	Jan 21/2005			4A	1	Mar 14/2007
32-09-12								2	Mar 14/2007
		1.1	1	Jan 21/2005				3	Mar 14/2007
			2	Jan 21/2005				4	Mar 14/2007

A = Added, R = Revised, D = Deleted, O = Overflow

32-EFFECTIVE PAGES

Page 1  
Aug 05/2009

D280T132



767-200/300

WIRING DIAGRAM MANUAL

CHAPTER 32  
LANDING GEAR

CH-SC-SU	Schem	Page	Sheet	Date	CH-SC-SU	Schem	Page	Sheet	Date
32-42-11 (cont.)		4A			32-61-14 (cont.)				
			5	Mar 14/2007		2A	1	Jan 21/2005	
		5A	1	Mar 14/2007			2	Jan 21/2005	
			2	Mar 14/2007		3	1	Jan 21/2005	
			3	Mar 14/2007			2	Jan 21/2005	
			4	Mar 14/2007		4A	1	Jan 21/2005	
			5	Mar 14/2007			2	Jan 21/2005	
32-42-12						5A	1	Jan 21/2005	
		1	1	Jan 21/2005			2	Jan 21/2005	
			2	Jan 21/2005		6A	1	Jan 21/2005	
		2	1	Jan 21/2005			2	Jan 21/2005	
			2	Jan 21/2005		7A	1	Jan 21/2005	
32-44-11							2	Jan 21/2005	
		1		Jan 21/2005	32-71-11				
		2		Jan 21/2005		1		Jan 21/2005	
32-45-11									
		1		Jan 21/2005					
		1.1		Mar 14/2007					
		2		Jan 21/2005					
		3.1		Jan 21/2005					
		4		Jan 21/2005					
		5		Jan 21/2005					
32-45-12									
		1		Jan 21/2005					
		1.1		Mar 14/2007					
		2		Jan 21/2005					
		3.1		Jan 21/2005					
		4		Jan 21/2005					
32-45-13									
		1		Jan 21/2005					
		1.1		Mar 14/2007					
		2		Jan 21/2005					
		3.1		Jan 21/2005					
		4		Jan 21/2005					
32-45-14									
		1		Jan 21/2005					
		1.1		Mar 14/2007					
		2		Jan 21/2005					
		3.1		Jan 21/2005					
		4		Jan 21/2005					
32-46-11									
		1	1	Jan 21/2005					
			2	Jan 21/2005					
32-61-11									
		1		Jan 21/2005					
32-61-12									
		1		Jan 21/2005					
32-61-13									
		1		Jan 21/2005					
32-61-14									
		1A	1	Jan 21/2005					
			2	Jan 21/2005					

A = Added, R = Revised, D = Deleted, O = Overflow

32-EFFECTIVE PAGES

Page 2  
Aug 05/2009

D280T132



767-200/300

WIRING DIAGRAM MANUAL

CHAPTER 32  
LANDING GEAR

Title	CH-SC-SU	Schem	Page	Sheet	Date	Effectivity
<b>LANDING GEAR MULTIPLE USE SYSTEMS/COMPONENTS</b>						
AIR/GROUND RELAYS- SYSTEM 1	32-09-11		1.1	1	Jan 21/2005	050-051
				2	Jan 21/2005	050-051
				3	Jan 21/2005	050-051
			2	1	Jan 21/2005	150-154
				2	Jan 21/2005	150-154
				3	Jan 21/2005	150-154
			2.1A	1	Jan 21/2005	150
				2	Jan 21/2005	150
				3	Jan 21/2005	150
			2.2	1	Jan 21/2005	151
				2	Jan 21/2005	151
				3	Jan 21/2005	151
			2.3B	1	Jan 21/2005	152-154
				2	Jan 21/2005	152-154
				3	Jan 21/2005	152-154
			3.1A	1	Jan 21/2005	155-156 162-166
				2	Jan 21/2005	155-156 162-166
				3	Jan 21/2005	155-156 162-166
			4.1A	1	Jan 21/2005	157
				2	Jan 21/2005	157
				3	Jan 21/2005	157
			5.1A	1	Jan 21/2005	167
				2	Jan 21/2005	167
				3	Jan 21/2005	167
			6.1	1	Jan 21/2005	275
				2	Jan 21/2005	275
				3	Jan 21/2005	275
			7.1	1	Jan 21/2005	276
				2	Jan 21/2005	276
				3	Jan 21/2005	276
			8.1	1	Jan 21/2005	277-278
				2	Jan 21/2005	277-278

**32-CONTENTS**

Page 1  
Jun 28/2006

D280T132



767-200/300

WIRING DIAGRAM MANUAL

CHAPTER 32  
LANDING GEAR

Title	CH-SC-SU	Schem	Page	Sheet	Date	Effectivity
AIR/GROUND RELAYS- SYSTEM 1 (cont.)	32-09-11			3	Jan 21/2005	277-278
			9.1	1	Jan 21/2005	280
				2	Jan 21/2005	280
				3	Jan 21/2005	280
AIR/GROUND RELAYS- SYSTEM 2	32-09-12		1.1	1	Jan 21/2005	050-051
				2	Jan 21/2005	050-051
			2.1	1	Jan 21/2005	150-156 275-276
				2	Jan 21/2005	150-156 275-276
			3.1	1	Jan 21/2005	157
				2	Jan 21/2005	157
			4.1	1	Jan 21/2005	162-166
				2	Jan 21/2005	162-166
			5.1	1	Jan 21/2005	167
				2	Jan 21/2005	167
			6.1	1	Jan 21/2005	277-278
				2	Jan 21/2005	277-278
			7.1	1	Jan 21/2005	280
				2	Jan 21/2005	280
AIR/GROUND RELAYS- SYSTEM 1 & 2	32-09-13		1.1		Mar 09/2006	050 150 152-156 162
			2.1		Mar 09/2006	051 151
			3.1		Mar 09/2006	157
			4.1		Mar 09/2006	163-167
			5.1		Mar 09/2006	275-276
			6.1		Mar 09/2006	277-280
PROXIMITY SWITCH ELECTRONICS UNIT OUTPUT INTERFACE	32-09-21			1	Jan 21/2005	050-099
				2	Jan 21/2005	150-199
			2.1		Jan 21/2005	153-154
			3		Jan 21/2005	275-299

**32-CONTENTS**

Page 2  
Jun 28/2006

D280T132



767-200/300

**WIRING DIAGRAM MANUAL**

**CHAPTER 32  
LANDING GEAR**

Title	CH-SC-SU	Schem	Page	Sheet	Date	Effectivity
<b><u>LANDING GEAR CONTROL</u></b>						
LANDING GEAR LEVER LOCK	32-31-11		1		Jan 21/2005	ALL
<b><u>LANDING GEAR ALTERNATE EXTEND SYSTEM</u></b>						
LANDING GEAR ALTERNATE EXTENSION SYSTEM	32-35-11		1		Jan 21/2005	ALL
<b><u>HYDRAULIC BRAKE SYSTEM</u></b>						
BRAKE PRESSURE INDICATION	32-41-11		1		Jan 21/2005	050-099
			2		Jan 21/2005	150-199 275-299
<b><u>ANTISKID/AUTOBRAKE SYSTEM</u></b>						
ANTISKID SYSTEM	32-42-11		1	1	Jan 21/2005	050-099
				2	Jan 21/2005	050-099
				3	Jan 21/2005	050-099
				4	Jan 21/2005	050-099
				5	Jan 21/2005	050-099
			2.1	1	Jan 21/2005	150-152
				2	Jan 21/2005	150-152
				3	Jan 21/2005	150-152
				4	Jan 21/2005	150-152
				5	Jan 21/2005	150-152
			3	1	Mar 14/2007	153-199
				2	Mar 14/2007	153-199
				3	Mar 14/2007	153-199
				4	Mar 14/2007	153-199
				5	Mar 14/2007	153-199
			4A	1	Mar 14/2007	275-276
				2	Mar 14/2007	275-276
				3	Mar 14/2007	275-276
				4	Mar 14/2007	275-276
				5	Mar 14/2007	275-276
			5A	1	Mar 14/2007	277-280
	2	Mar 14/2007	277-280			
	3	Mar 14/2007	277-280			

**32-CONTENTS**



767-200/300

WIRING DIAGRAM MANUAL

CHAPTER 32  
LANDING GEAR

Title	CH-SC-SU	Schem	Page	Sheet	Date	Effectivity
ANTISKID SYSTEM (cont.)	32-42-11			4	Mar 14/2007	277-280
				5	Mar 14/2007	277-280
AUTOBRAKE SYSTEM	32-42-12		1	1	Jan 21/2005	050-099 150-199
				2	Jan 21/2005	050-099 150-199
				2	Jan 21/2005	275-299
				2	Jan 21/2005	275-299
<b><u>PARKING BRAKE SYSTEM</u></b>						
PARKING BRAKE SYSTEM	32-44-11			1	Jan 21/2005	050-099
				2	Jan 21/2005	150-199 275-299
<b><u>TIRES AND WHEELS</u></b>						
TIRE PRESSURE INDICATION SYSTEM- POWER & MONITORING	32-45-11		1		Jan 21/2005	050-099 155-199
				1.1	Mar 14/2007	157-162
				2	Jan 21/2005	150-154
				3.1	Jan 21/2005	275-276
				4	Jan 21/2005	277-278
				5	Jan 21/2005	280-299
TIRE PRESSURE INDICATION SYSTEM- NOSE GEAR SENSORS	32-45-12		1		Jan 21/2005	050-099 155-199
				1.1	Mar 14/2007	157-162
				2	Jan 21/2005	150-154
				3.1	Jan 21/2005	275-276
				4	Jan 21/2005	277-299
TIRE PRESSURE INDICATION SYSTEM-LEFT MAIN GEAR SENSORS	32-45-13		1		Jan 21/2005	050-099 155-199
				1.1	Mar 14/2007	157-162
				2	Jan 21/2005	150-154
				3.1	Jan 21/2005	275-276
				4	Jan 21/2005	277-299
TIRE PRESSURE INDICATION SYSTEM-RIGHT MAIN GEAR SENSORS	32-45-14		1		Jan 21/2005	050-099 155-199
				1.1	Mar 14/2007	157-162

**32-CONTENTS**

Page 4  
Mar 14/2007

D280T132



767-200/300

WIRING DIAGRAM MANUAL

CHAPTER 32  
LANDING GEAR

Title	CH-SC-SU	Schem	Page	Sheet	Date	Effectivity
TIRE PRESSURE INDICATION SYSTEM-RIGHT MAIN GEAR SENSORS (cont.)	32-45-14		2		Jan 21/2005	150-154
			3.1		Jan 21/2005	275-276
			4		Jan 21/2005	277-299
<b><u>BRAKE TEMPERATURE MONITORING SYSTEM</u></b>						
BRAKE TEMPERATURE MONITORING SYSTEM	32-46-11		1	1	Jan 21/2005	ALL
				2	Jan 21/2005	ALL
<b><u>LANDING GEAR POSITION INDICATING AND WARNING SYSTEM</u></b>						
LANDING GEAR POSITION INDICATION- LEFT GEAR	32-61-11		1		Jan 21/2005	ALL
LANDING GEAR POSITION INDICATION- RIGHT GEAR	32-61-12		1		Jan 21/2005	ALL
LANDING GEAR POSITION INDICATION- NOSE GEAR	32-61-13		1		Jan 21/2005	ALL
LANDING GEAR POSITION INDICATION	32-61-14		1A	1	Jan 21/2005	050-051
				2	Jan 21/2005	050-051
			2A	1	Jan 21/2005	150-152 155-156 162-166
				2	Jan 21/2005	150-152 155-156 162-166
			3	1	Jan 21/2005	153-154
				2	Jan 21/2005	153-154
			4A	1	Jan 21/2005	157 167
				2	Jan 21/2005	157 167
			5A	1	Jan 21/2005	275-276
				2	Jan 21/2005	275-276
			6A	1	Jan 21/2005	277-278
				2	Jan 21/2005	277-278
			7A	1	Jan 21/2005	280
				2	Jan 21/2005	280
<b><u>TAIL SKID SYSTEM</u></b>						
TAIL SKID CONTROL & INDICATION	32-71-11		1		Jan 21/2005	150-199 275-299

**32-CONTENTS**





767-200/300

## WIRING DIAGRAM MANUAL

### CHAPTER 32 LANDING GEAR

CH-SC-SU	Title
32-09-11	AIR/GROUND RELAYS- SYSTEM 1
32-09-13	AIR/GROUND RELAYS- SYSTEM 1 & 2
32-09-12	AIR/GROUND RELAYS- SYSTEM 2
32-42-11	ANTISKID SYSTEM
32-42-12	AUTOBRAKE SYSTEM
32-41-11	BRAKE PRESSURE INDICATION
32-46-11	BRAKE TEMPERATURE MONITORING SYSTEM
32-35-11	LANDING GEAR ALTERNATE EXTENSION SYSTEM
32-31-11	LANDING GEAR LEVER LOCK
32-61-14	LANDING GEAR POSITION INDICATION
32-61-11	LANDING GEAR POSITION INDICATION- LEFT GEAR
32-61-13	LANDING GEAR POSITION INDICATION- NOSE GEAR
32-61-12	LANDING GEAR POSITION INDICATION- RIGHT GEAR
32-44-11	PARKING BRAKE SYSTEM
32-09-21	PROXIMITY SWITCH ELECTRONICS UNIT OUTPUT INTERFACE
32-71-11	TAIL SKID CONTROL & INDICATION
32-45-12	TIRE PRESSURE INDICATION SYSTEM- NOSE GEAR SENSORS
32-45-11	TIRE PRESSURE INDICATION SYSTEM- POWER & MONITORING
32-45-13	TIRE PRESSURE INDICATION SYSTEM-LEFT MAIN GEAR SENSORS
32-45-14	TIRE PRESSURE INDICATION SYSTEM-RIGHT MAIN GEAR SENSORS

## 32-ALPHABETICAL INDEX

D280T132

Page 1  
Jan 21/2005

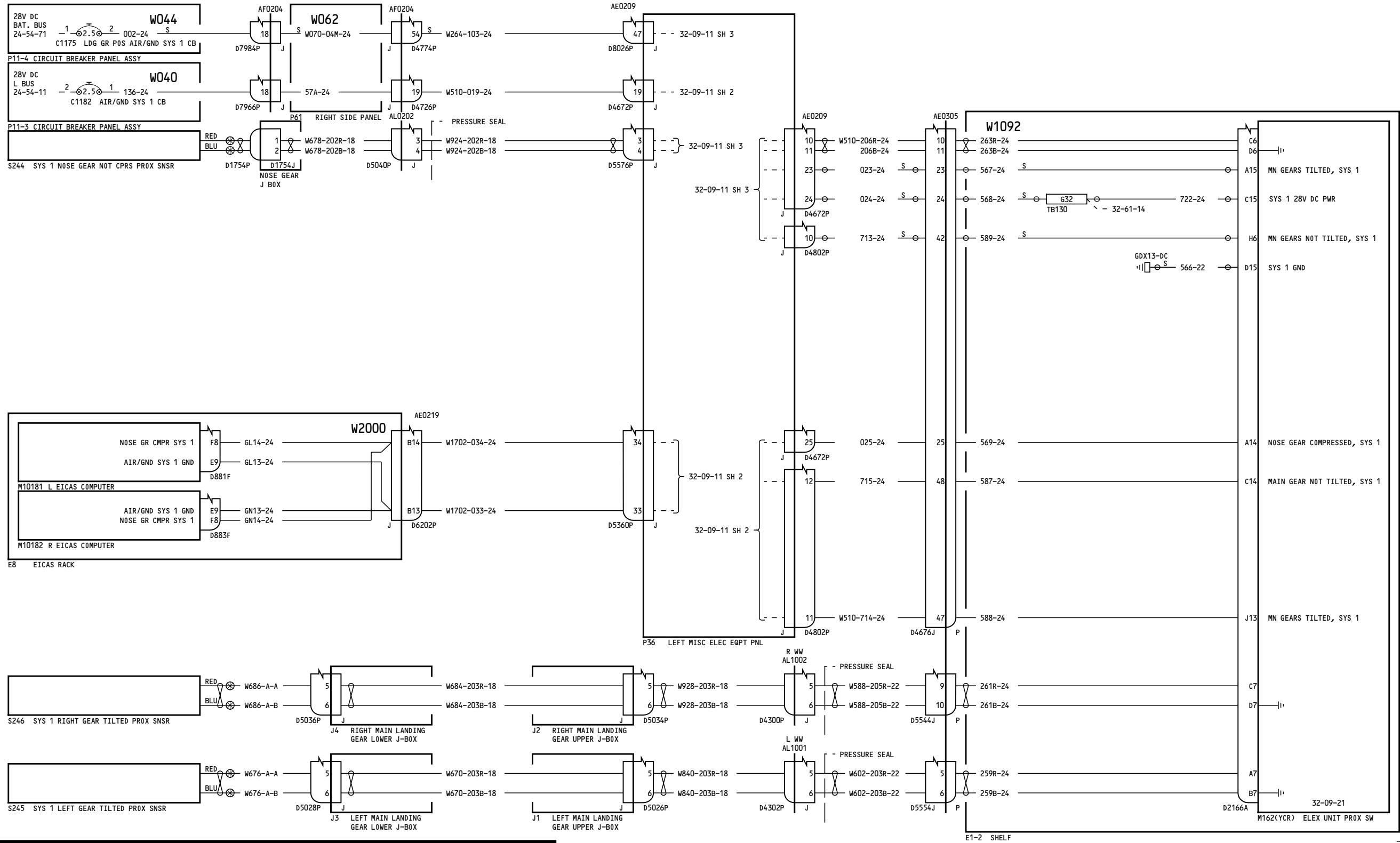

050-051

**AIR/GROUND RELAYS-SYSTEM 1**

D280T132

**32-09-11**

Page 1.1  
Sheet 1  
Jan 21/2005

Incorporates  
78-0051FAA

**32-09-11**

Page 1.1  
Sheet 1  
Jan 21/2005

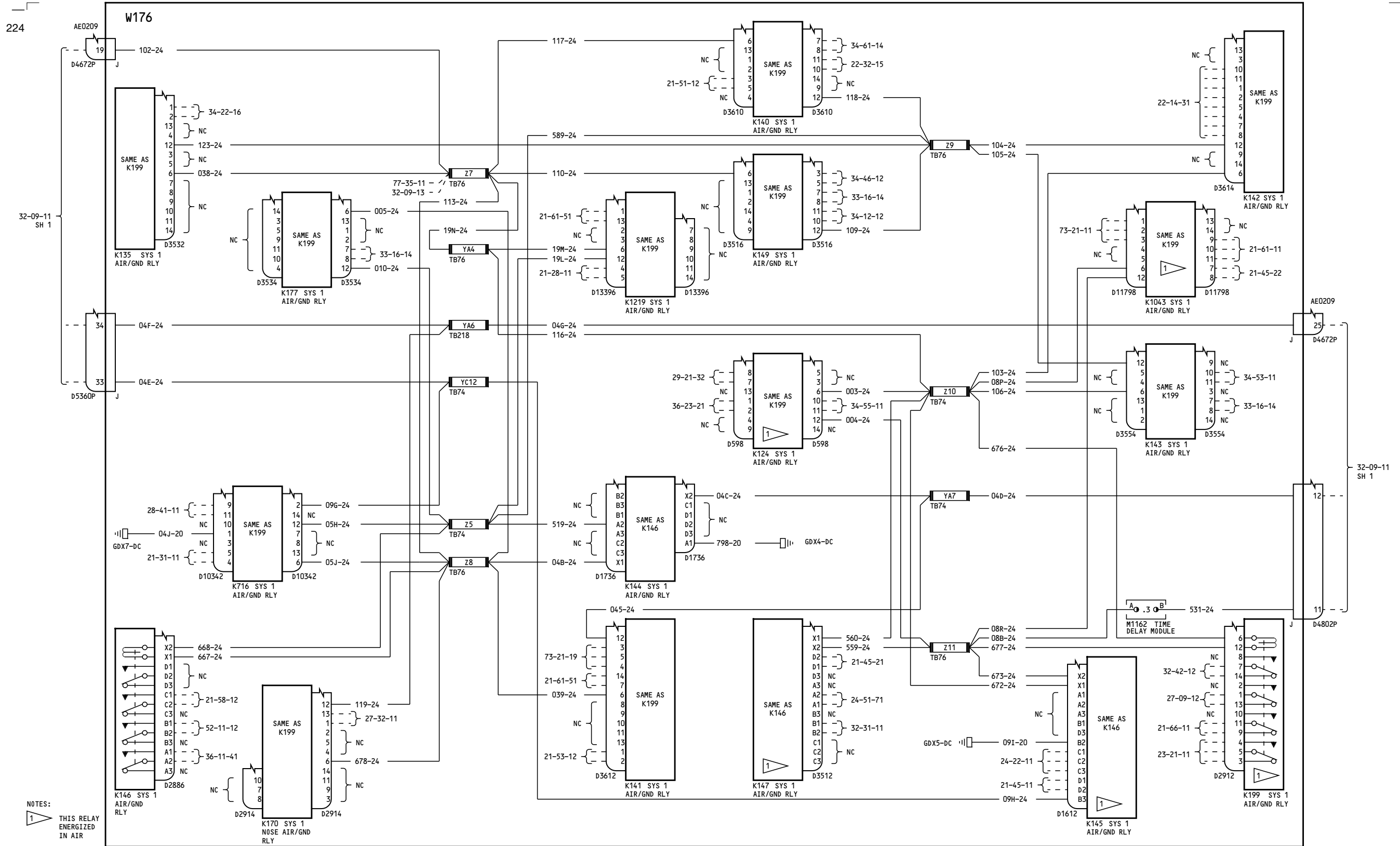

NOTES:  
 THIS RELAY ENERGIZED IN AIR

050-051  
**AIR/GROUND RELAYS-SYSTEM 1**  
 D280T132

**32-09-11**

Page 1.1  
 Sheet 2  
 Jan 21/2005

Incorporates  
 78-0062 R04

**32-09-11**

Page 1.1  
 Sheet 2  
 Jan 21/2005

180

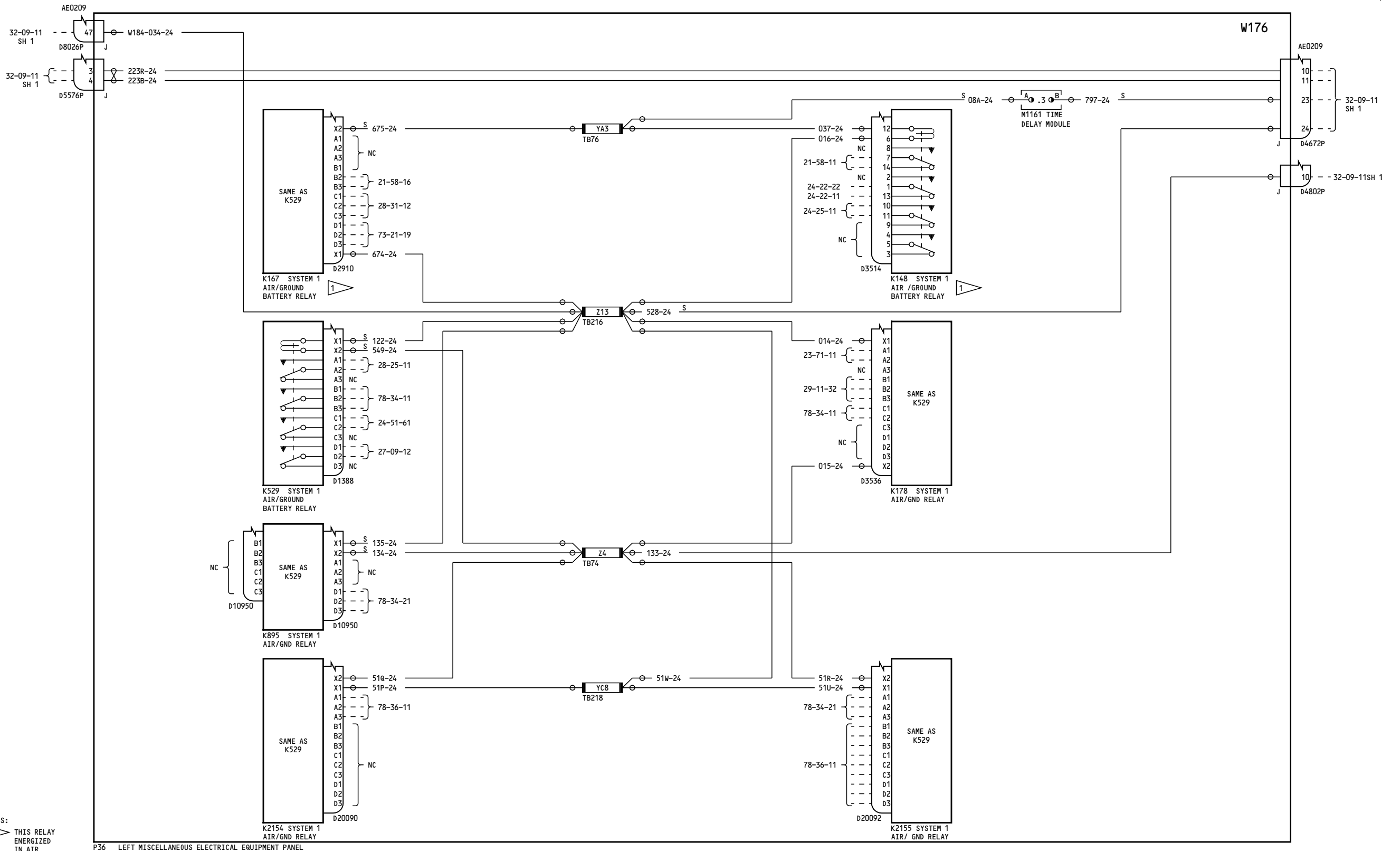

NOTES:  
 1 THIS RELAY ENERGIZED IN AIR

050-051

**AIR/GROUND RELAYS-  
SYSTEM 1**

D280T132

**32-09-11**

Page 1.1  
 Sheet 3  
 Jan 21/2005

Incorporates  
 78-0062 R04

**32-09-11**

Page 1.1  
 Sheet 3  
 Jan 21/2005

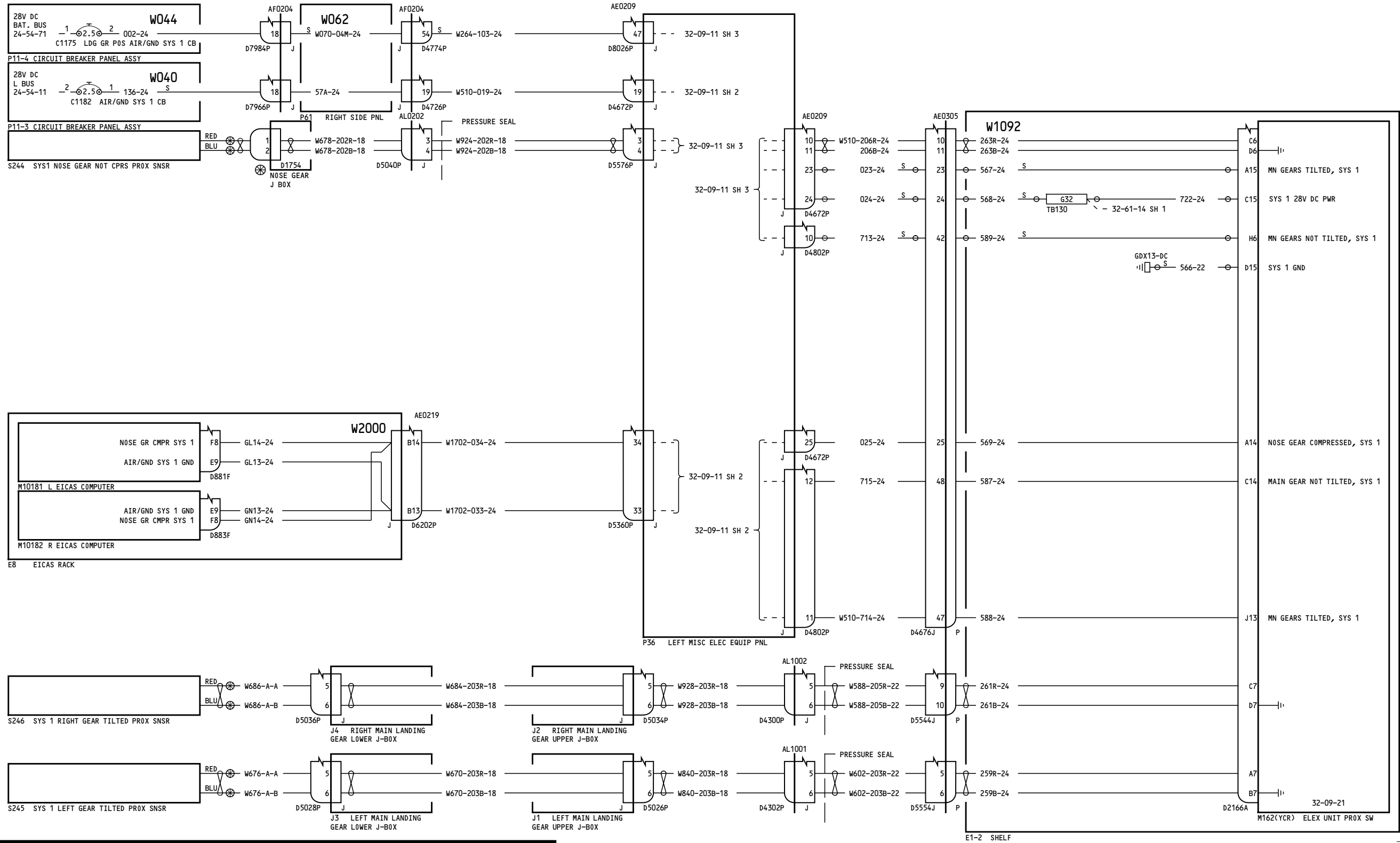

150-154

**AIR/GROUND RELAYS-SYSTEM 1**

D280T132

32-09-11

Page 2  
Sheet 1  
Jan 21/2005

32-09-11

Page 2  
Sheet 1  
Jan 21/2005

59

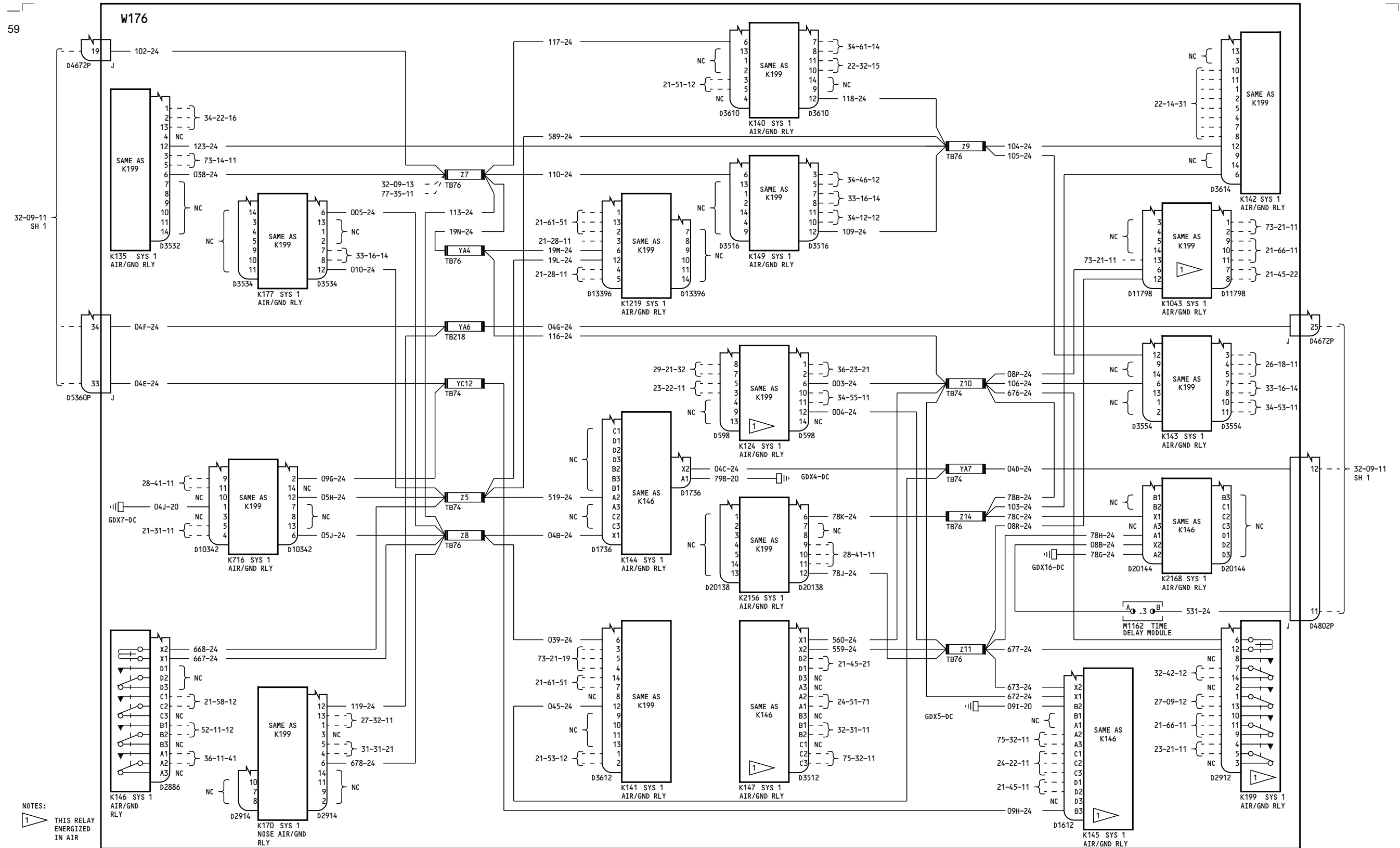

NOTES:  
 THIS RELAY ENERGIZED IN AIR

P36 LEFT MISCELLANEOUS ELECTRICAL EQUIPMENT PANEL

150-154

**AIR/GROUND RELAYS SYSTEM 1**

D280T132

**32-09-11**

Page 2  
 Sheet 2  
 Jan 21/2005

**32-09-11**

Page 2  
 Sheet 2  
 Jan 21/2005

59

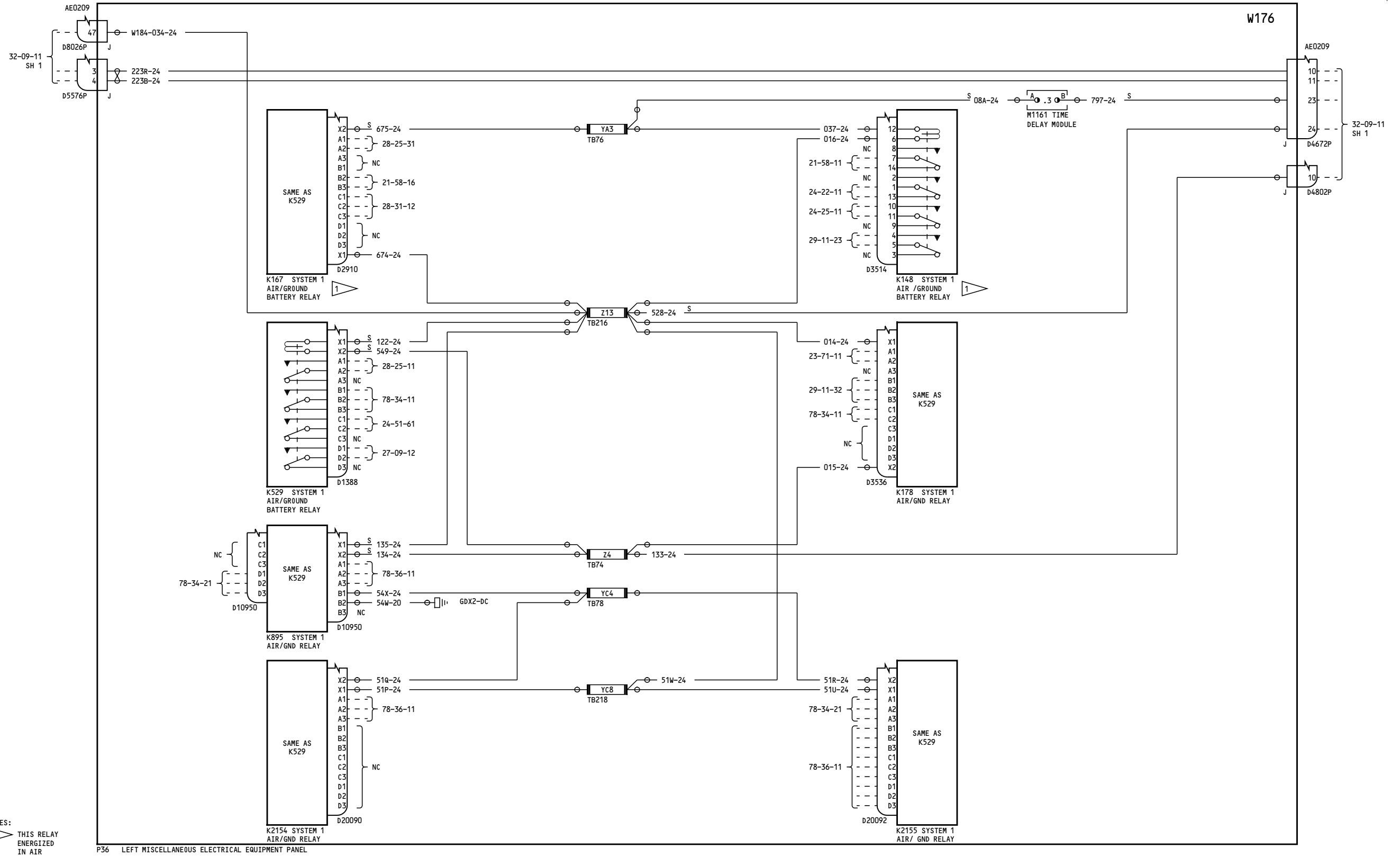

NOTES:  
 1 THIS RELAY ENERGIZED IN AIR

P36 LEFT MISCELLANEOUS ELECTRICAL EQUIPMENT PANEL

150-154

**AIR/GROUND RELAYS-SYSTEM 1**

**32-09-11**

Page 2  
Sheet 3  
Jan 21/2005

D280T132

**32-09-11**

Page 2  
Sheet 3  
Jan 21/2005

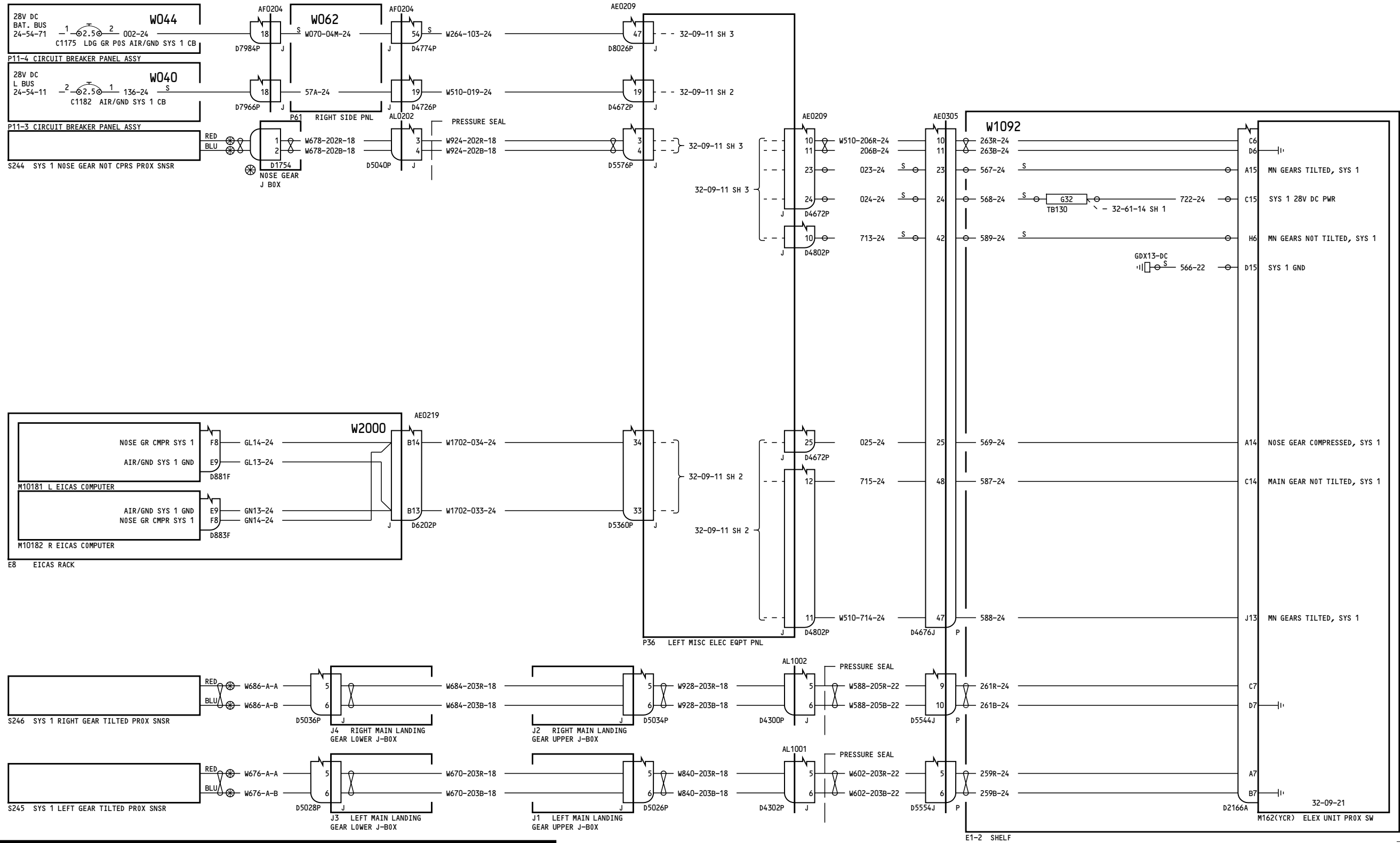

150

**AIR/GROUND RELAYS-SYSTEM 1**

D280T132

**32-09-11**

Page 2.1A  
Sheet 1  
Jan 21/2005

Incorporates  
78-0051FAA

**32-09-11**

Page 2.1A  
Sheet 1  
Jan 21/2005



378

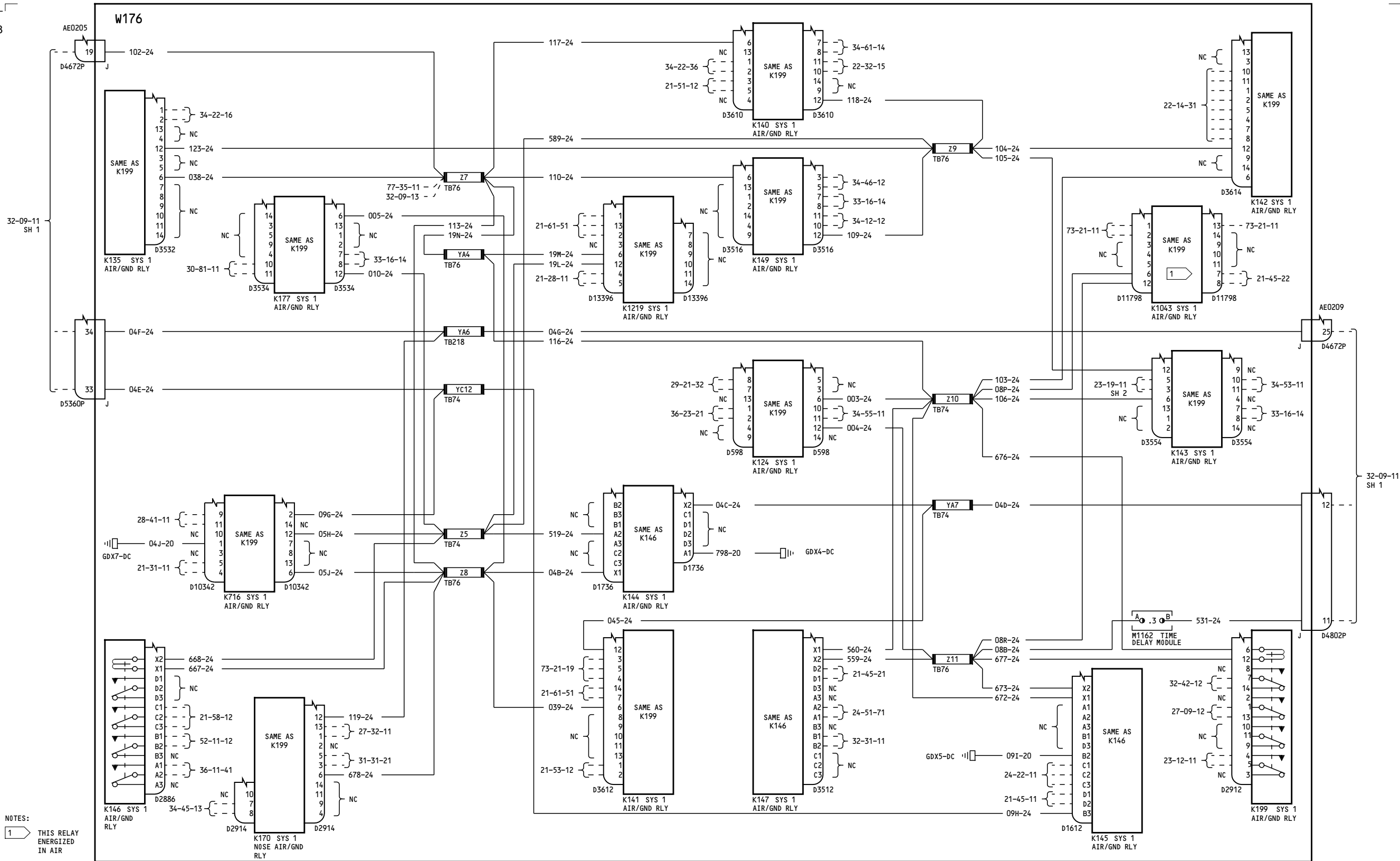

NOTES:  
 1 THIS RELAY ENERGIZED IN AIR

P36 LEFT MISC ELEC EQPT PNL

150

**AIR/GROUND RELAYS-  
SYSTEM 1**

D280T132

32-09-11

Page 2.1A  
 Sheet 2  
 Jan 21/2005

- Incorporates
- 25-0113 R04
  - 30-0017
  - 76-0030 R02
  - 78-0062 R04
  - MTO-230695

BOEING PROPRIETARY - Copyright © - Unpublished Work - See title page for details.

32-09-11

Page 2.1A  
 Sheet 2  
 Jan 21/2005

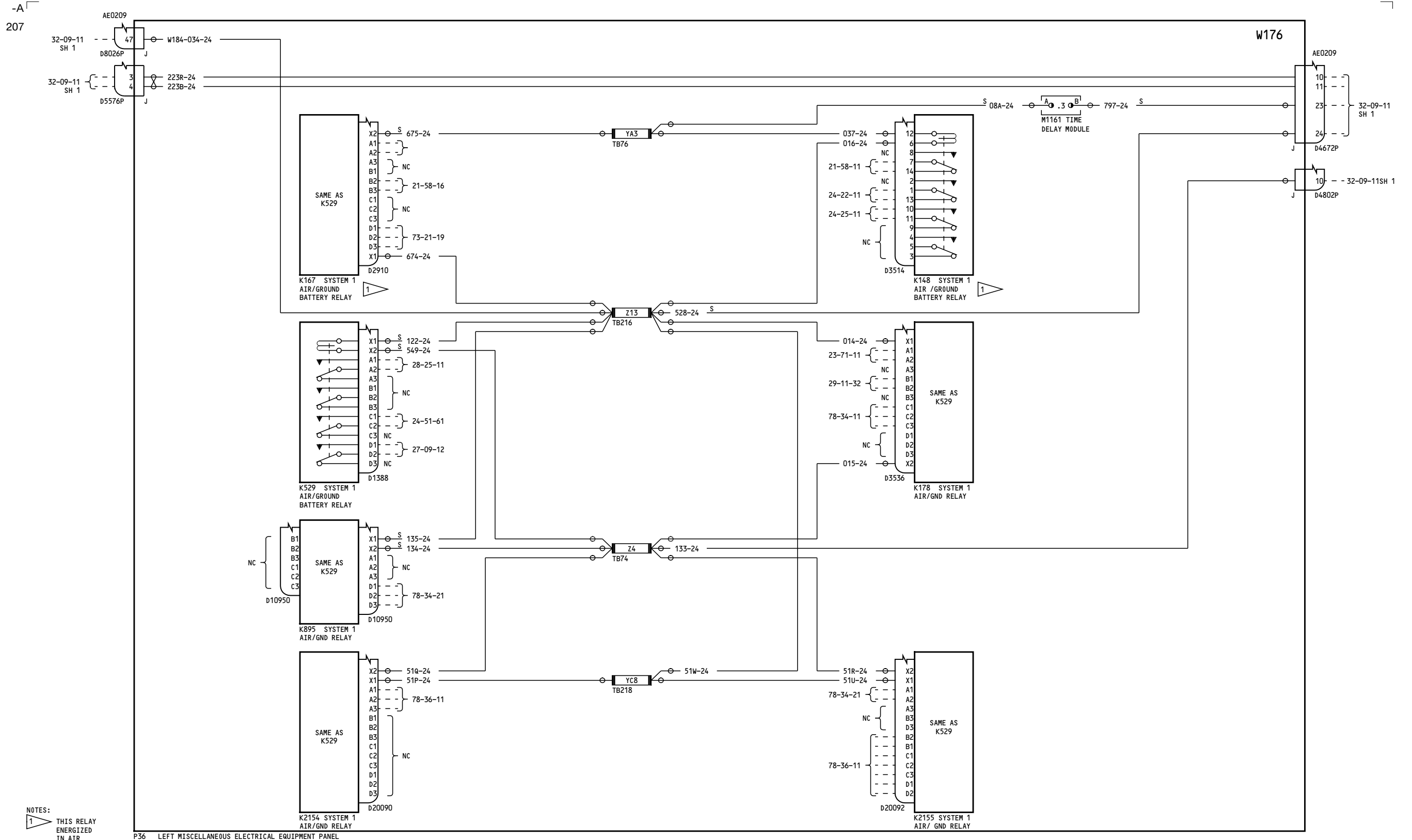

NOTES:  
 1 THIS RELAY ENERGIZED IN AIR

P36 LEFT MISCELLANEOUS ELECTRICAL EQUIPMENT PANEL

150	<b>AIR/GROUND RELAYS- SYSTEM 1</b>  D280T132
-----	--

**32-09-11**

Page 2.1A  
 Sheet 3  
 Jan 21/2005

Incorporates  
 78-0051FAA  
 78-0062 R04

**32-09-11**

Page 2.1A  
 Sheet 3  
 Jan 21/2005

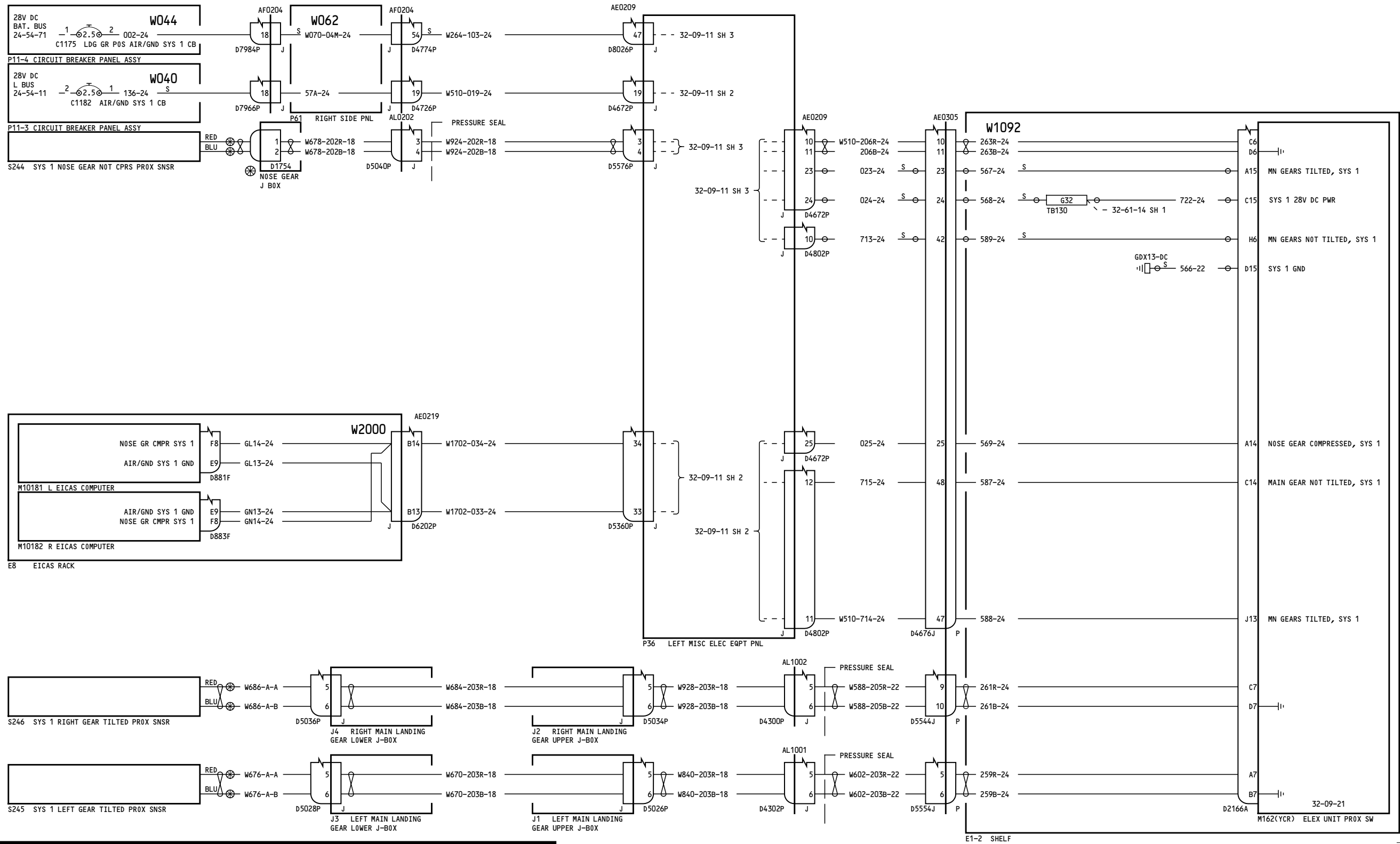

151

**AIR/GROUND RELAYS-SYSTEM 1**

**32-09-11**

Incorporates  
78-0051FAA

**32-09-11**

D280T132

Page 2.2  
Sheet 1  
Jan 21/2005

Page 2.2  
Sheet 1  
Jan 21/2005

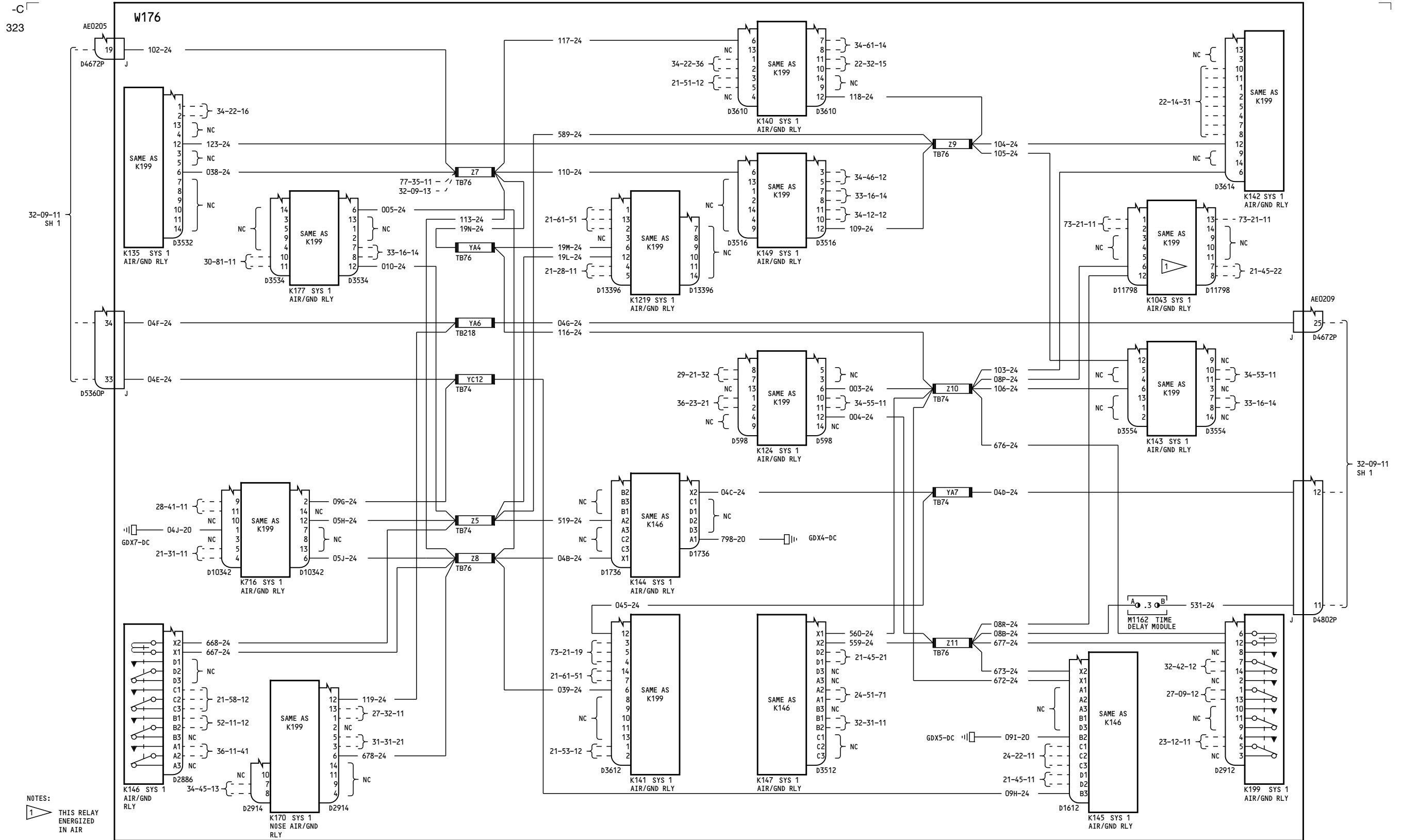

P36 LEFT MISC ELEC EQPT PNL

151

**AIR/GROUND RELAYS-  
SYSTEM 1**

**32-09-11**

Page 2.2  
Sheet 2  
Jan 21/2005

- Incorporates
- 25-0113 R04
  - 30-0017
  - 76-0030 R02
  - 78-0062 R04

D280T132

**32-09-11**

Page 2.2  
Sheet 2  
Jan 21/2005

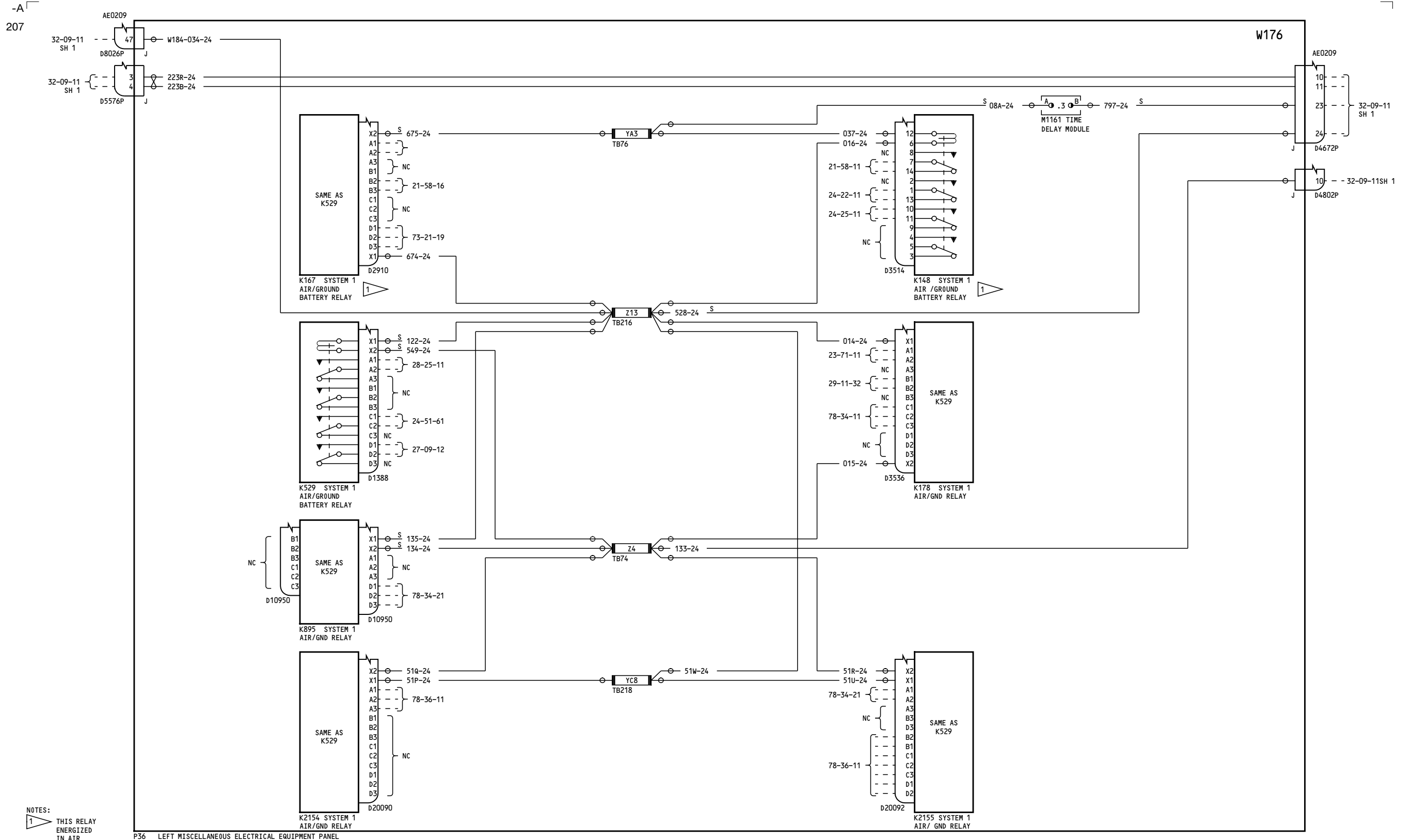

NOTES:  
 1 THIS RELAY ENERGIZED IN AIR

P36 LEFT MISCELLANEOUS ELECTRICAL EQUIPMENT PANEL

151

**AIR/GROUND RELAYS- SYSTEM 1**

**32-09-11**

Page 2.2  
 Sheet 3  
 Jan 21/2005

D280T132

Incorporates  
 78-0051FAA  
 78-0062 R04

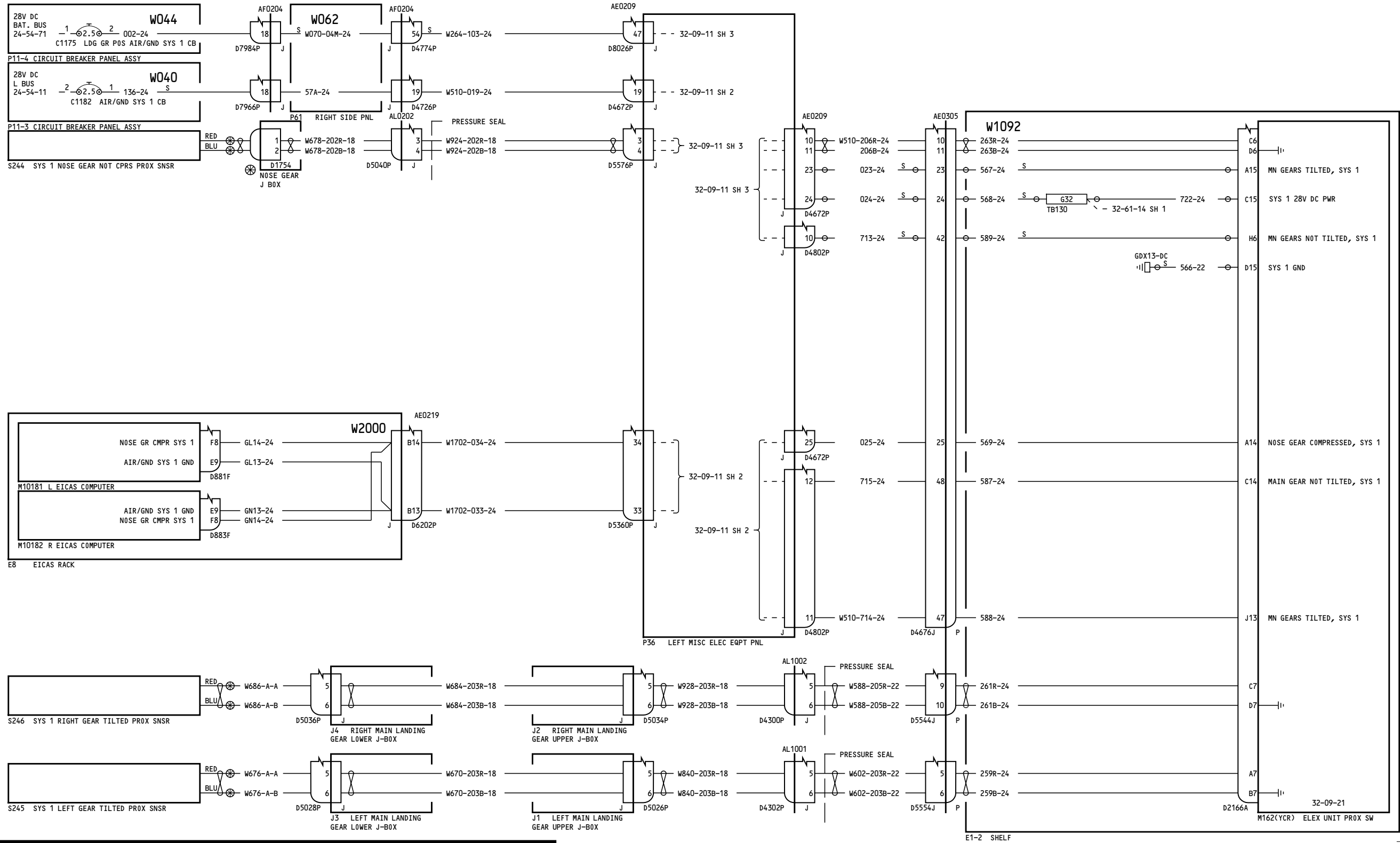

152-154

AIR/GROUND RELAYS-SYSTEM 1  
D280T132

32-09-11

Page 2.3B  
Sheet 1  
Jan 21/2005

Incorporates  
78-0051FAA

32-09-11

Page 2.3B  
Sheet 1  
Jan 21/2005

378

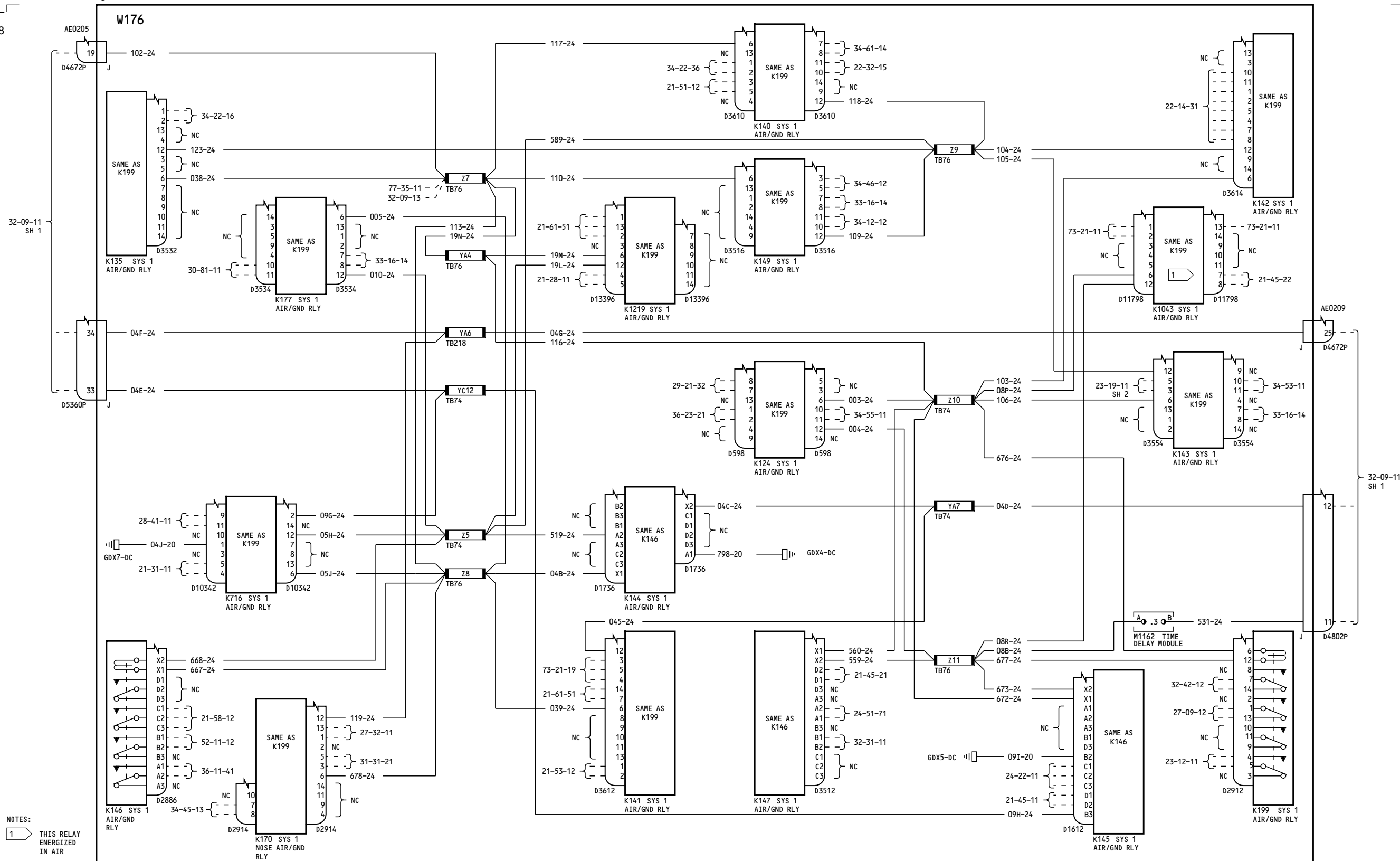

NOTES:  
1 THIS RELAY ENERGIZED IN AIR

152-154

**AIR/GROUND RELAYS-  
SYSTEM 1**

D280T132

**32-09-11**

Page 2.3B  
Sheet 2  
Jan 21/2005

- Incorporates
- 25-0113 R04
  - 30-0017
  - 76-0030 R02
  - 78-0062 R04
  - MTO-230596

**32-09-11**

Page 2.3B  
Sheet 2  
Jan 21/2005

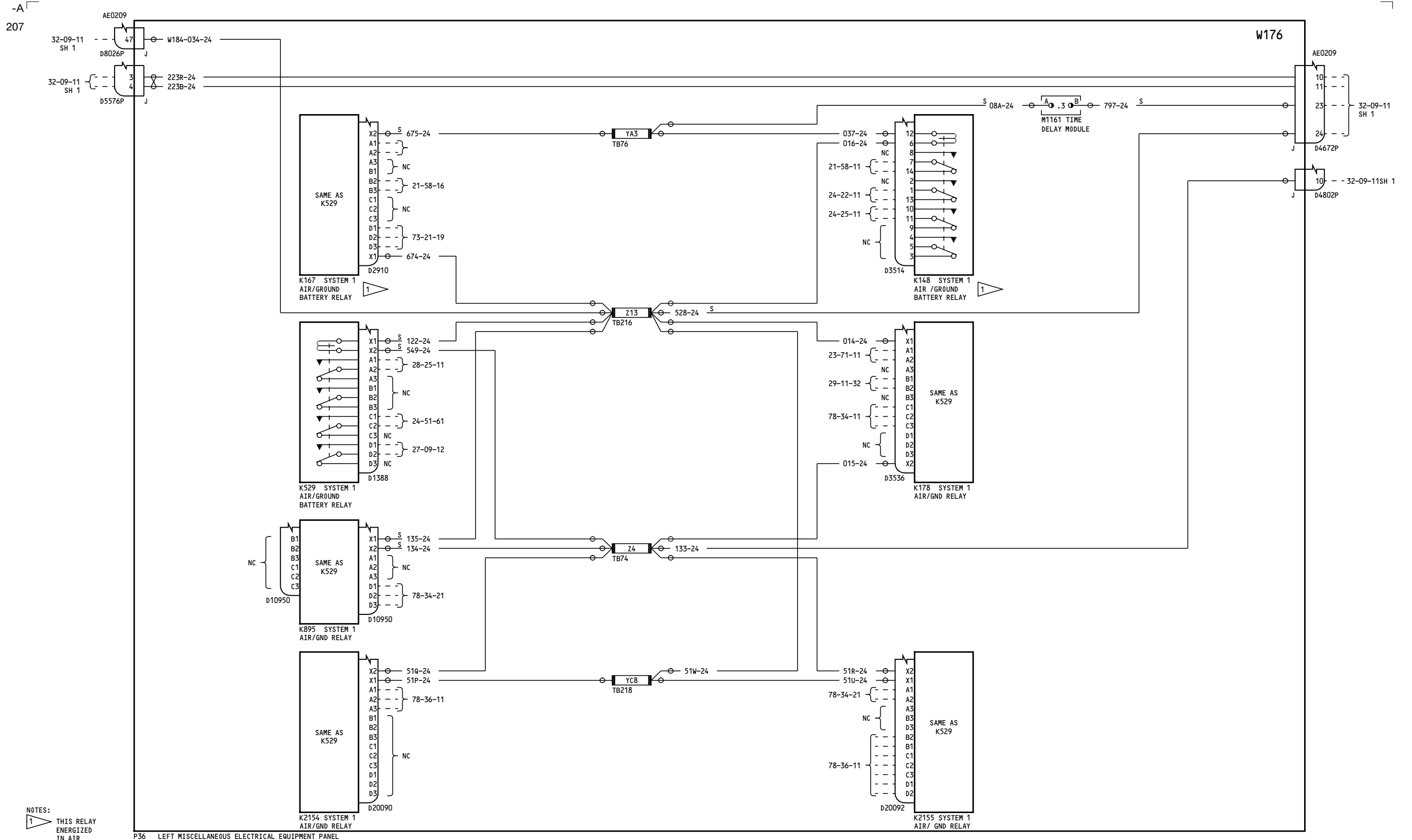

NOTES:  
 1 THIS RELAY ENERGIZED IN AIR

P36 LEFT MISCELLANEOUS ELECTRICAL EQUIPMENT PANEL

152-154	<b>AIR/GROUND RELAYS- SYSTEM 1</b>
	D280T132

**32-09-11**

Page 2.3B  
 Sheet 3  
 Jan 21/2005

Incorporates  
 78-0051FAA  
 78-0062 R04

**32-09-11**

Page 2.3B  
 Sheet 3  
 Jan 21/2005



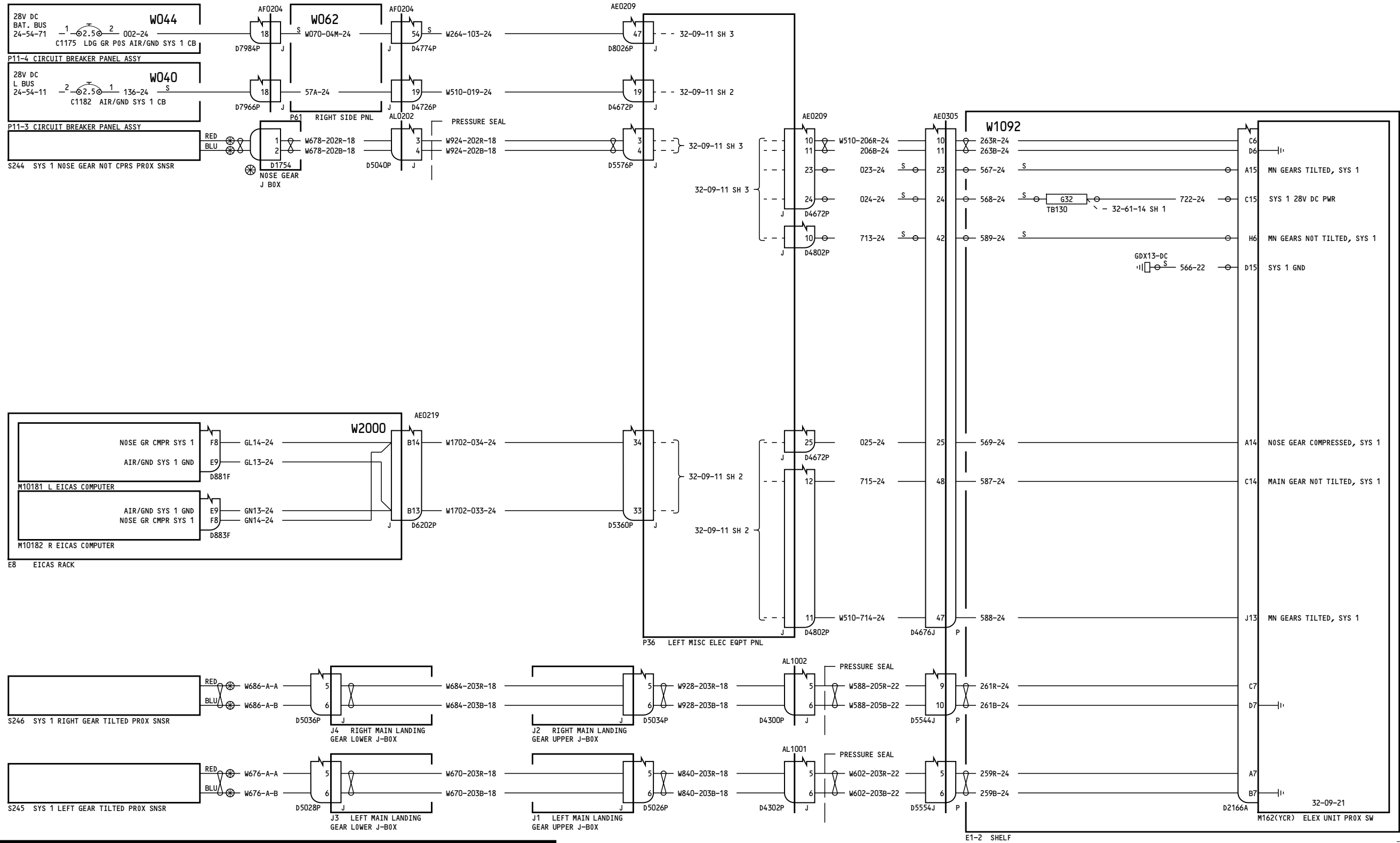

155-156, 162-166

AIR/GROUND RELAYS-SYSTEM 1

D280T132

32-09-11

Page 3.1A  
Sheet 1  
Jan 21/2005

Incorporates  
78-0051FAA

32-09-11

Page 3.1A  
Sheet 1  
Jan 21/2005

-A  
243

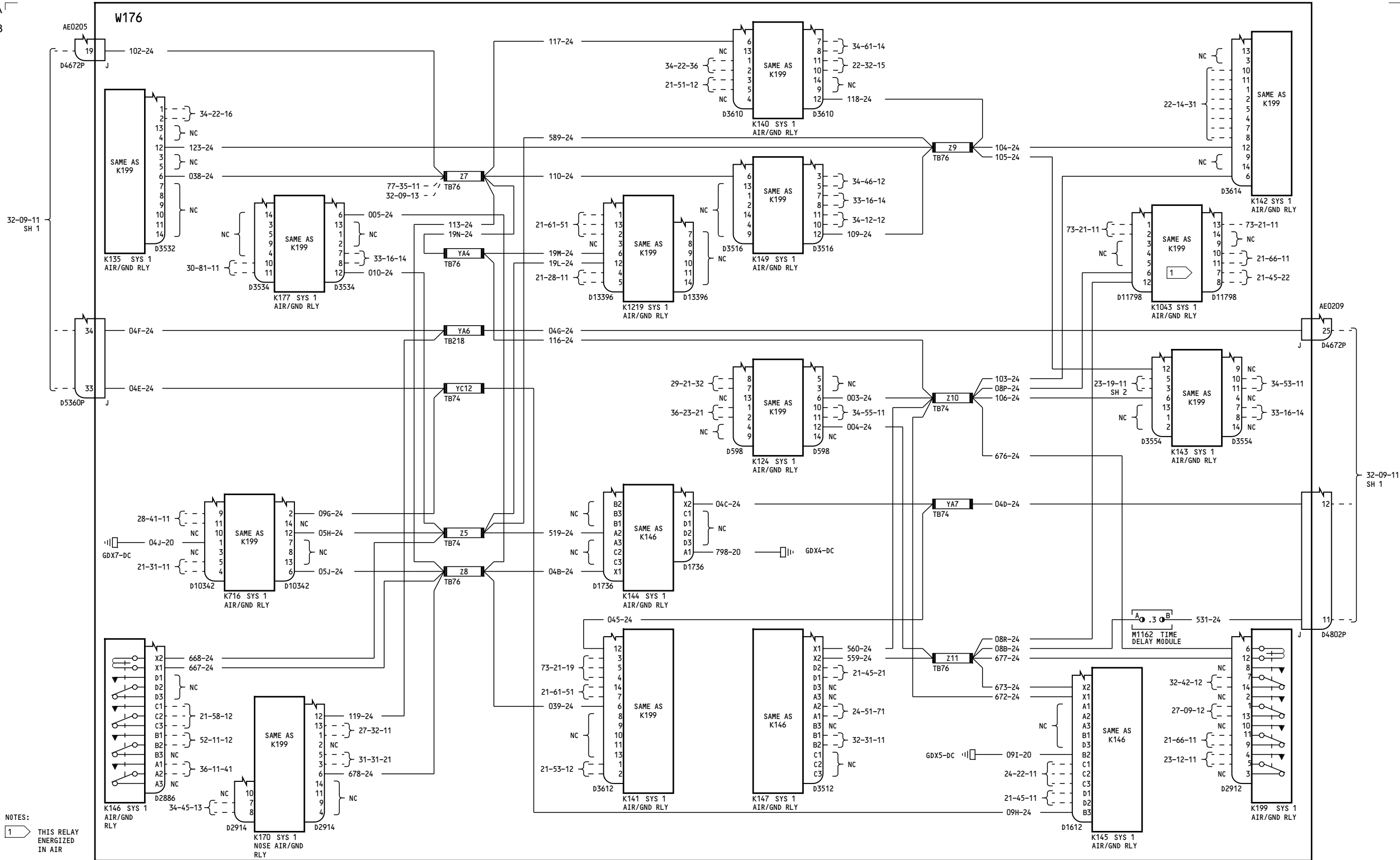

NOTES:  
 1 THIS RELAY ENERGIZED IN AIR

155-156, 162-166

AIR/GROUND RELAYS-SYSTEM 1

D280T132

32-09-11

Page 3.1A  
Sheet 2  
Jan 21/2005

Incorporates  
 78-0062 R04  
 MTO-230596

32-09-11

Page 3.1A  
Sheet 2  
Jan 21/2005

172

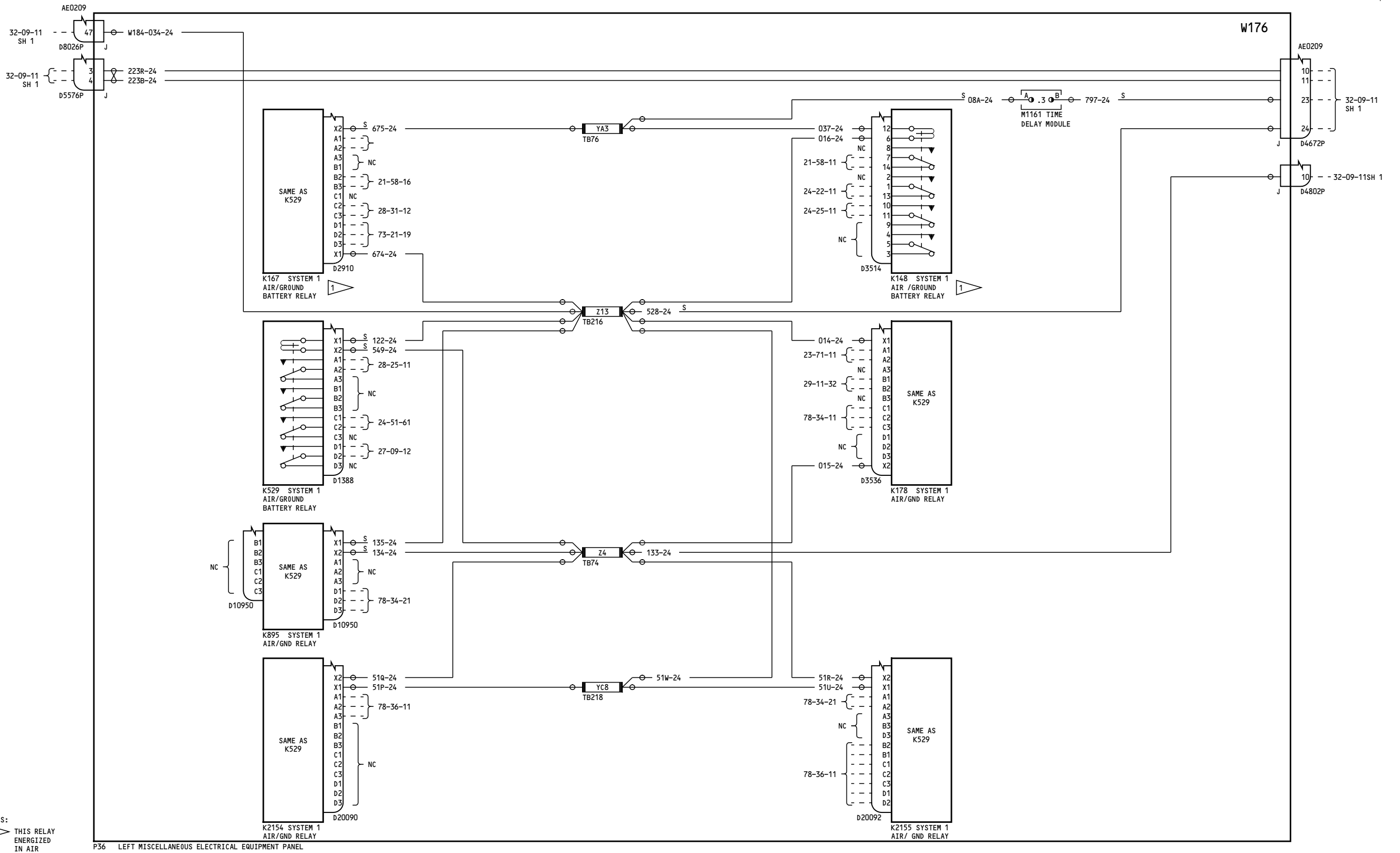

NOTES:  
 1 THIS RELAY ENERGIZED IN AIR

P36 LEFT MISCELLANEOUS ELECTRICAL EQUIPMENT PANEL

155-156, 162-166

**AIR/GROUND RELAYS-  
SYSTEM 1**

**32-09-11**

Page 3.1A  
 Sheet 3  
 Jan 21/2005

D280T132

Incorporates  
 78-0051FAA  
 78-0062 R04

**32-09-11**

Page 3.1A  
 Sheet 3  
 Jan 21/2005

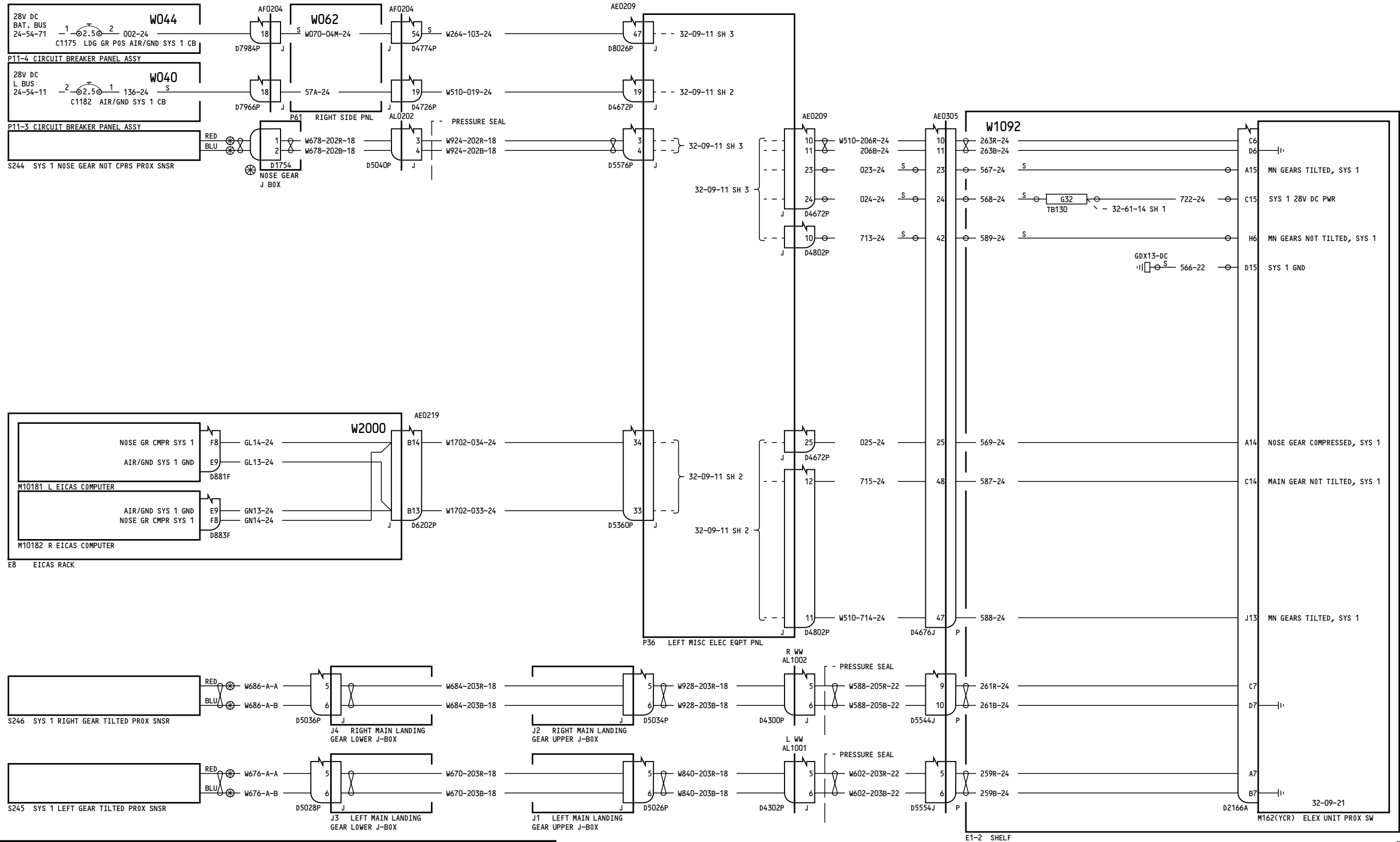

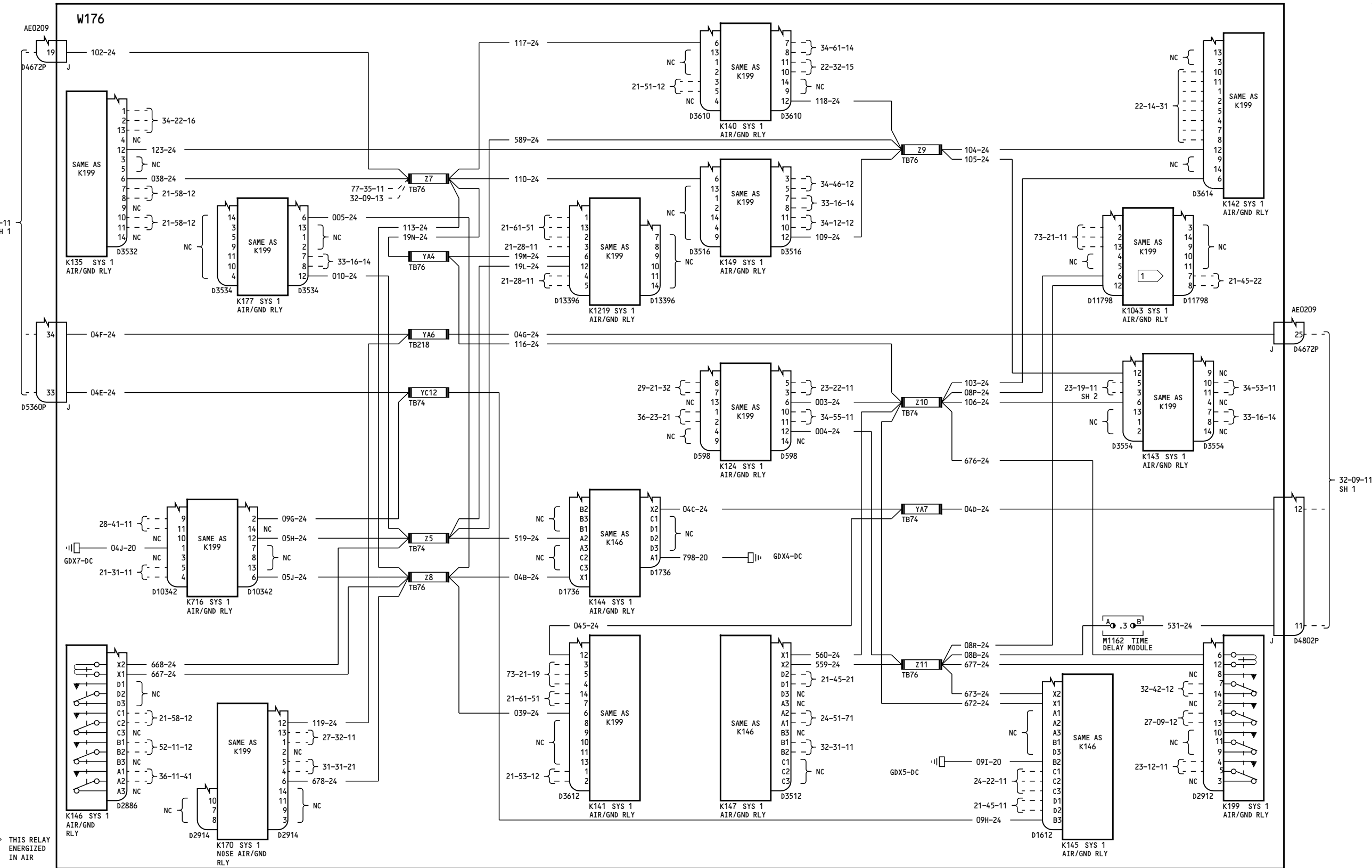

NOTES:  
1 THIS RELAY ENERGIZED IN AIR

**AIR/GROUND RELAYS-SYSTEM 1**

**32-09-11**

Page 4.1A  
Sheet 2  
Jan 21/2005

D280T132

Incorporates  
78-0062 R04  
MTO-230596

**32-09-11**

Page 4.1A  
Sheet 2  
Jan 21/2005

189

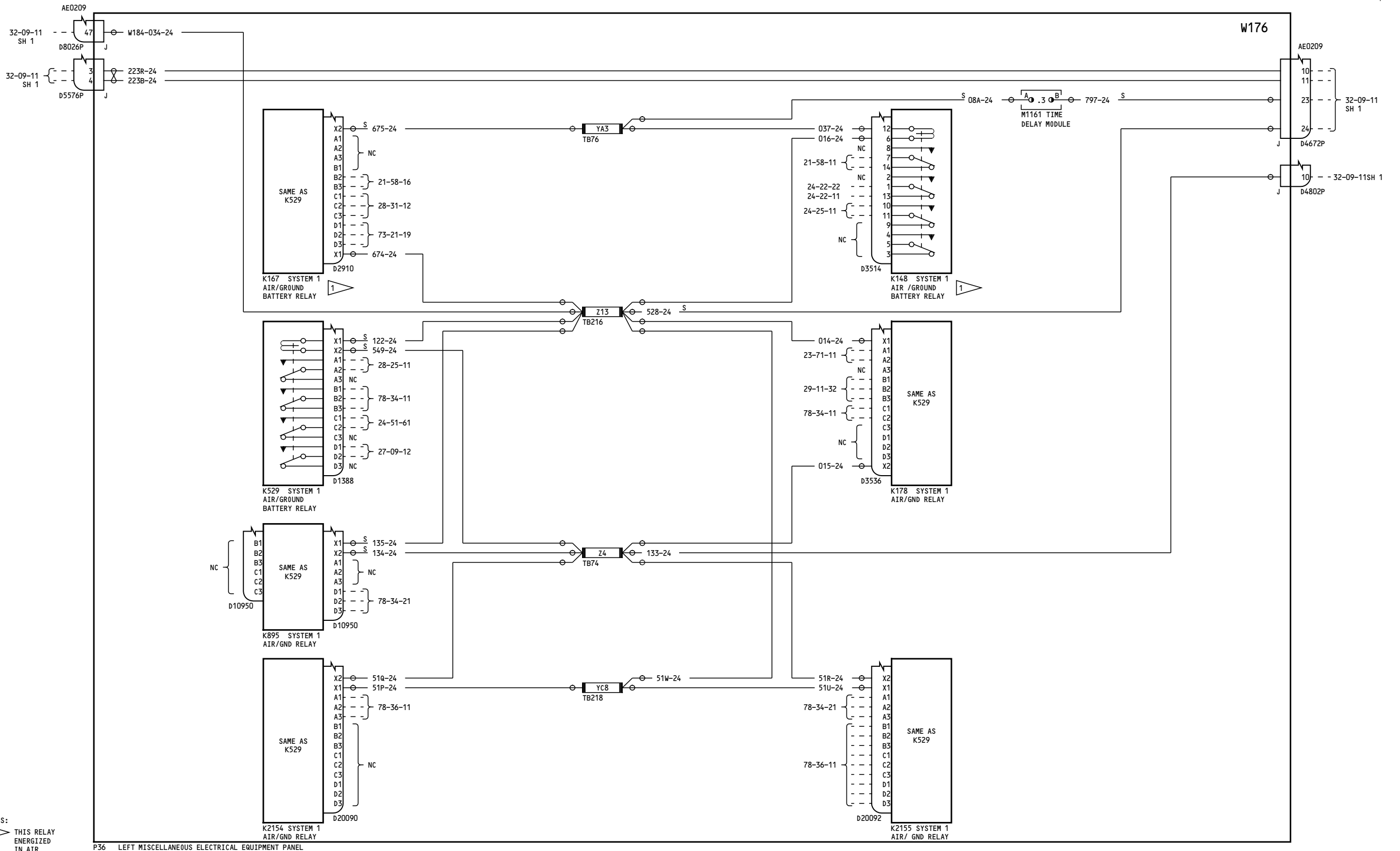

NOTES:  
 1 THIS RELAY ENERGIZED IN AIR

P36 LEFT MISCELLANEOUS ELECTRICAL EQUIPMENT PANEL

157	<b>AIR/GROUND RELAYS- SYSTEM 1</b>  D280T132
-----	--

**32-09-11**

Page 4.1A  
 Sheet 3  
 Jan 21/2005

Incorporates  
 78-0062 R04

**32-09-11**

Page 4.1A  
 Sheet 3  
 Jan 21/2005

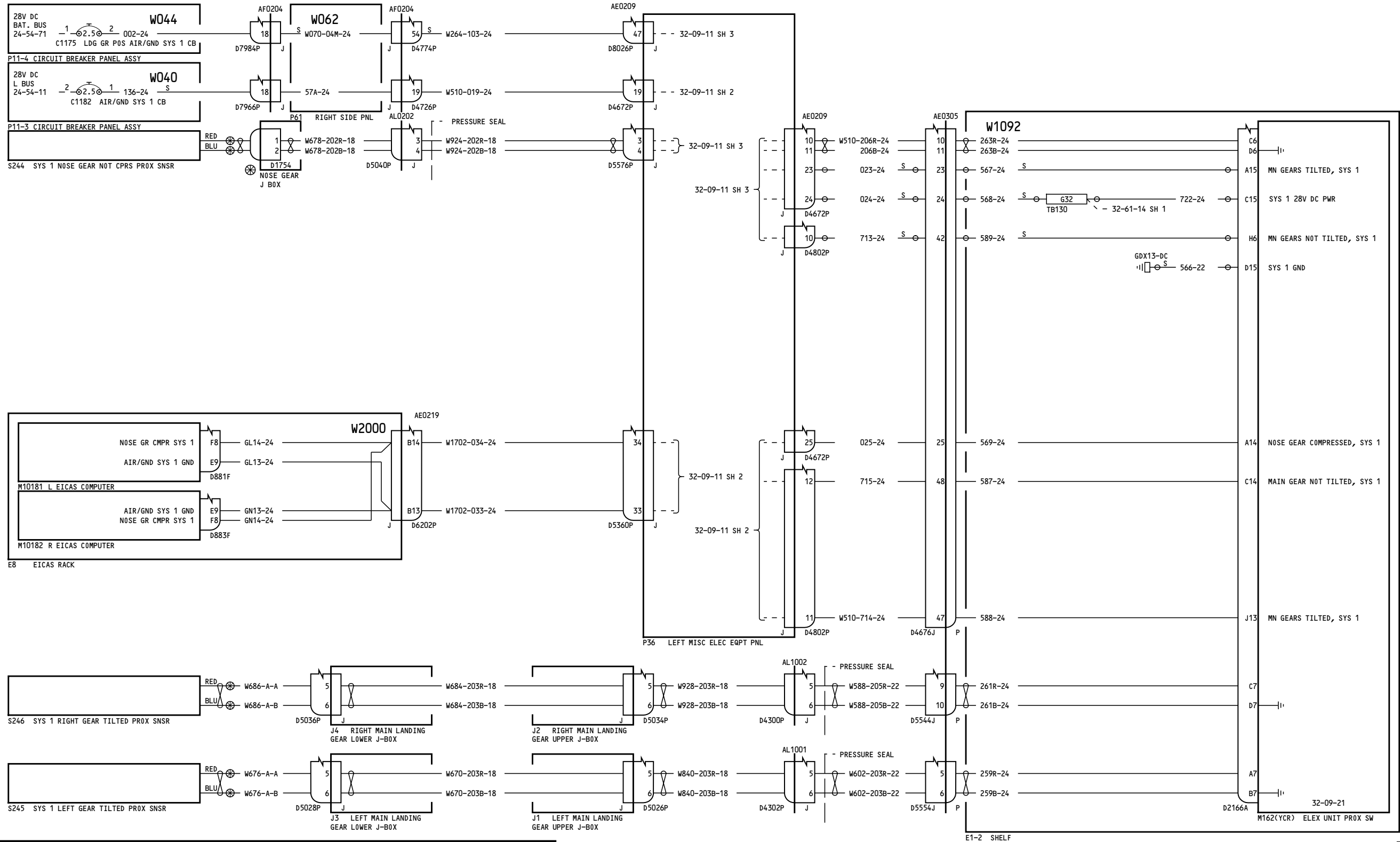

-A  
264

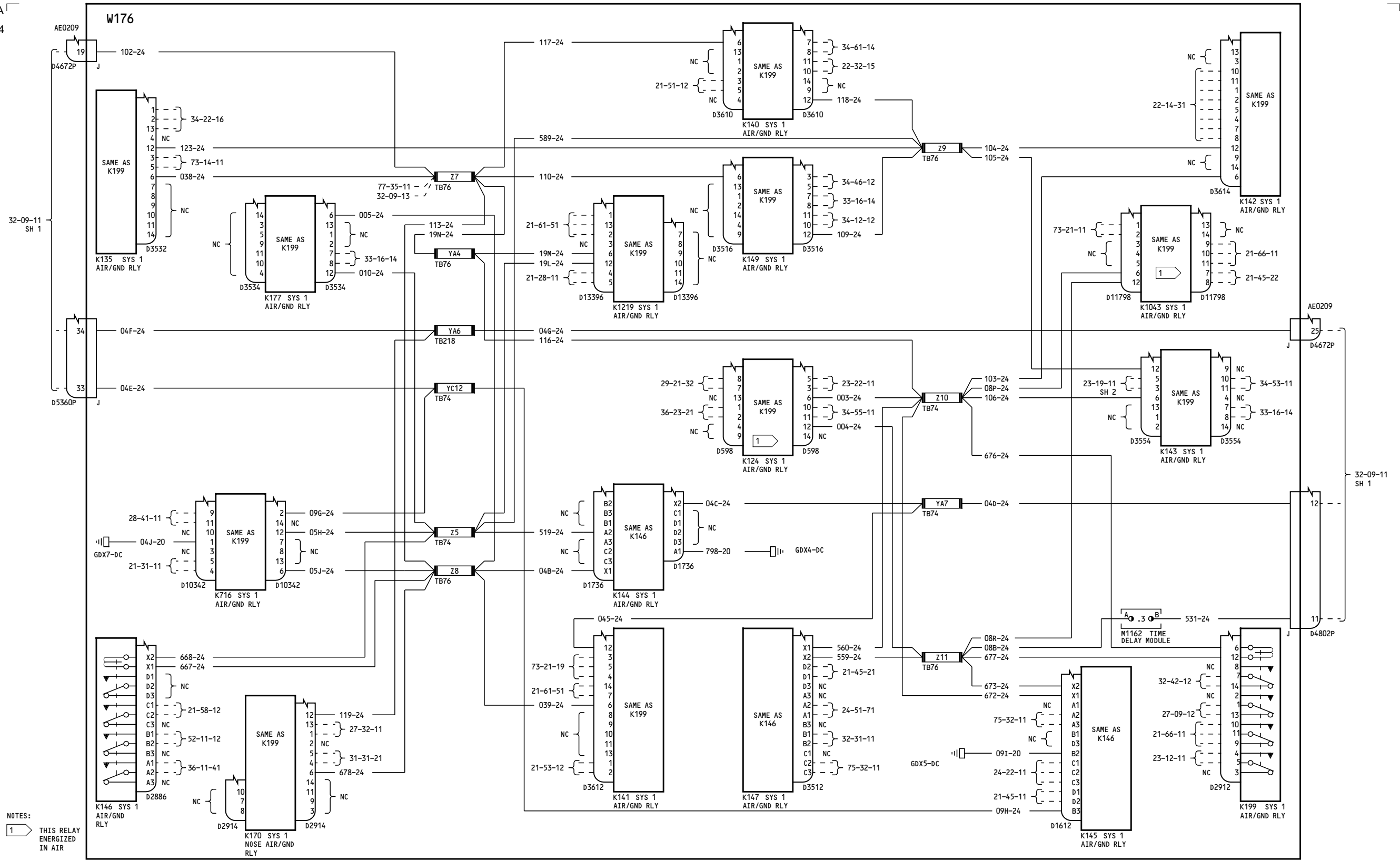

NOTES:  
 1 THIS RELAY ENERGIZED IN AIR

167

AIR/GROUND RELAYS- SYSTEM 1

D280T132

32-09-11

Page 5.1A  
Sheet 2  
Jan 21/2005

Incorporates  
 78-0062 R04  
 MTO-230596

32-09-11

Page 5.1A  
Sheet 2  
Jan 21/2005



184

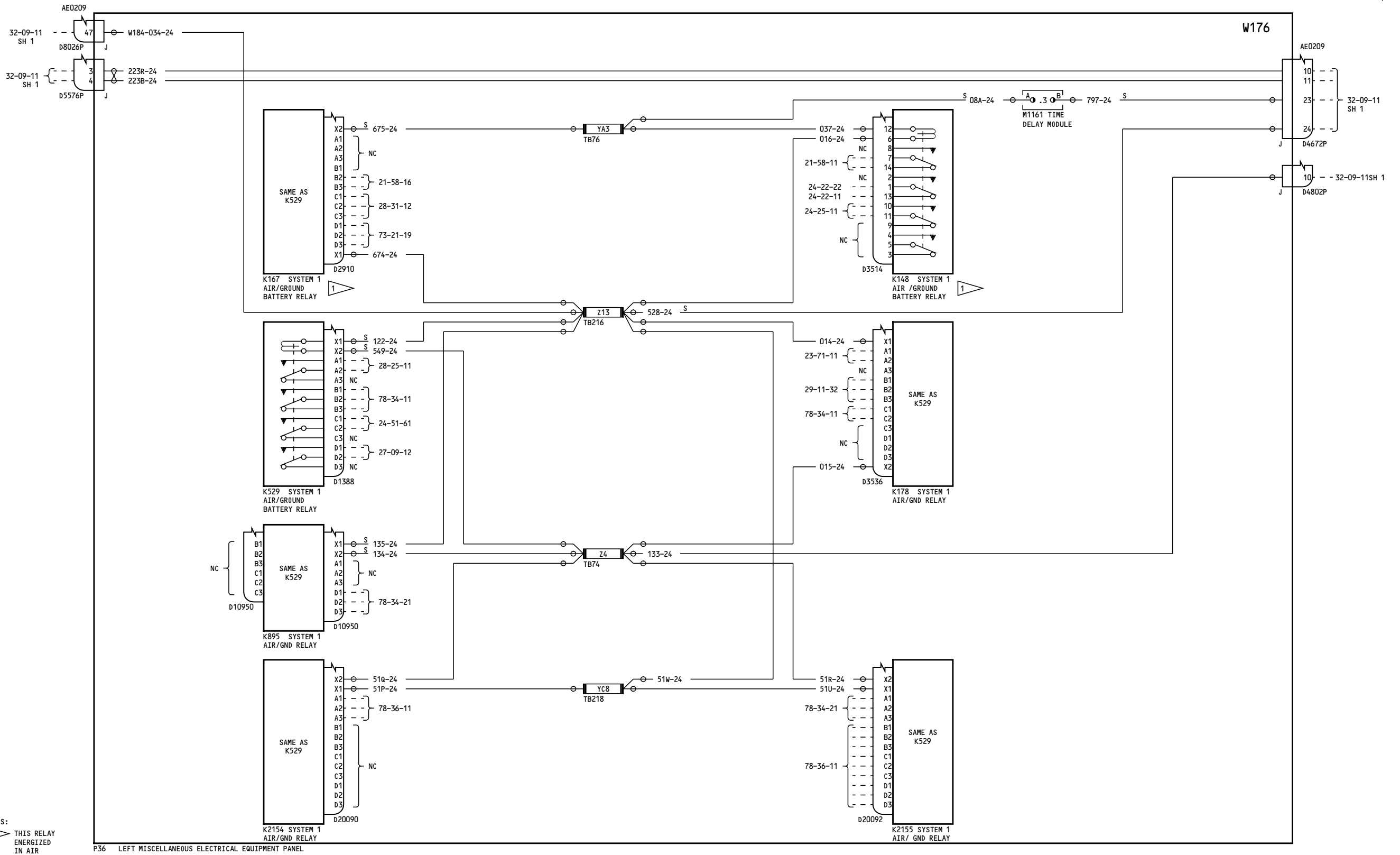

NOTES:  
 1 THIS RELAY ENERGIZED IN AIR

167

**AIR/GROUND RELAYS-  
SYSTEM 1**

**32-09-11**

Page 5.1A  
 Sheet 3  
 Jan 21/2005

D280T132

Incorporates  
 78-0062 R04

**32-09-11**

Page 5.1A  
 Sheet 3  
 Jan 21/2005

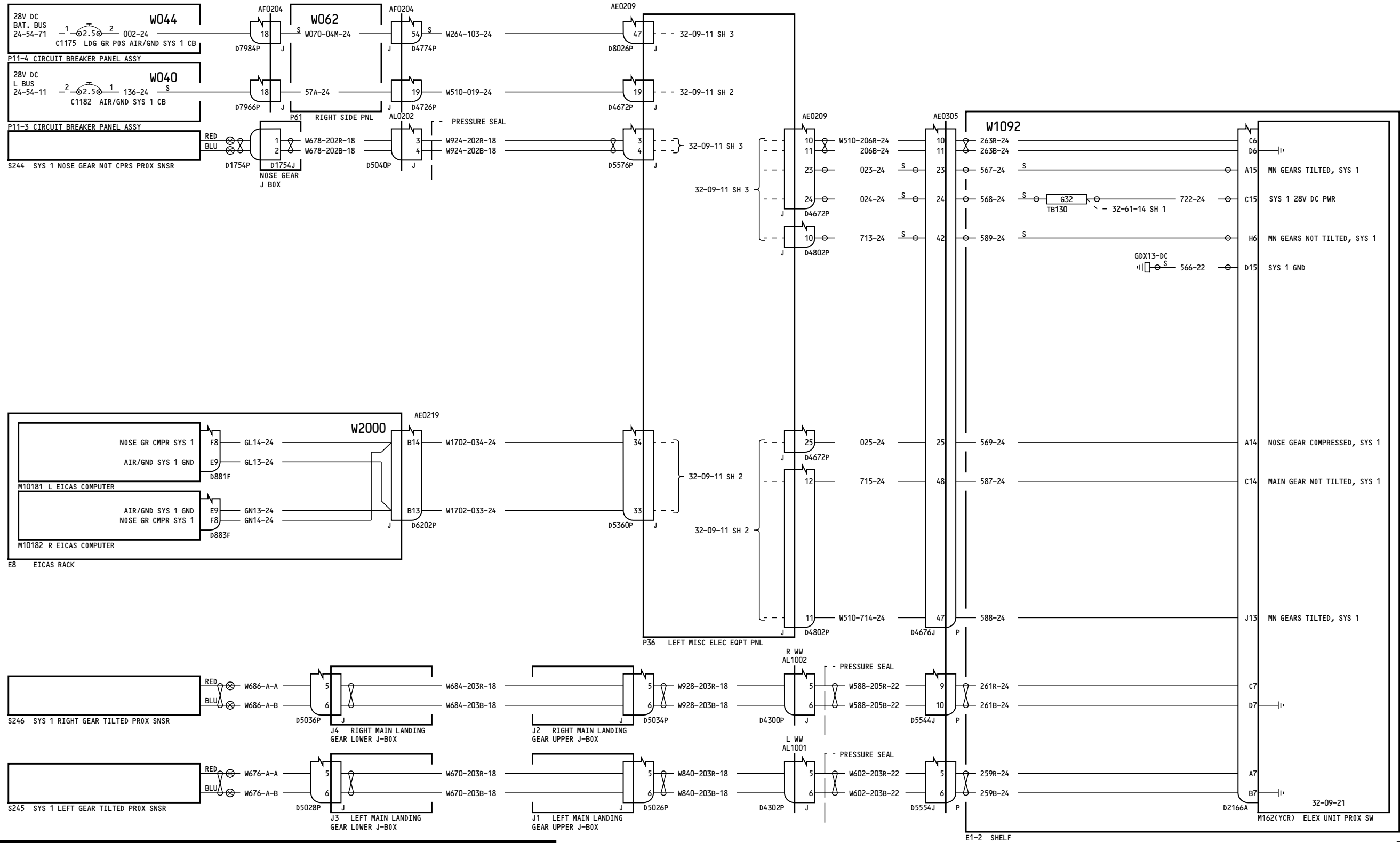

-A  
235

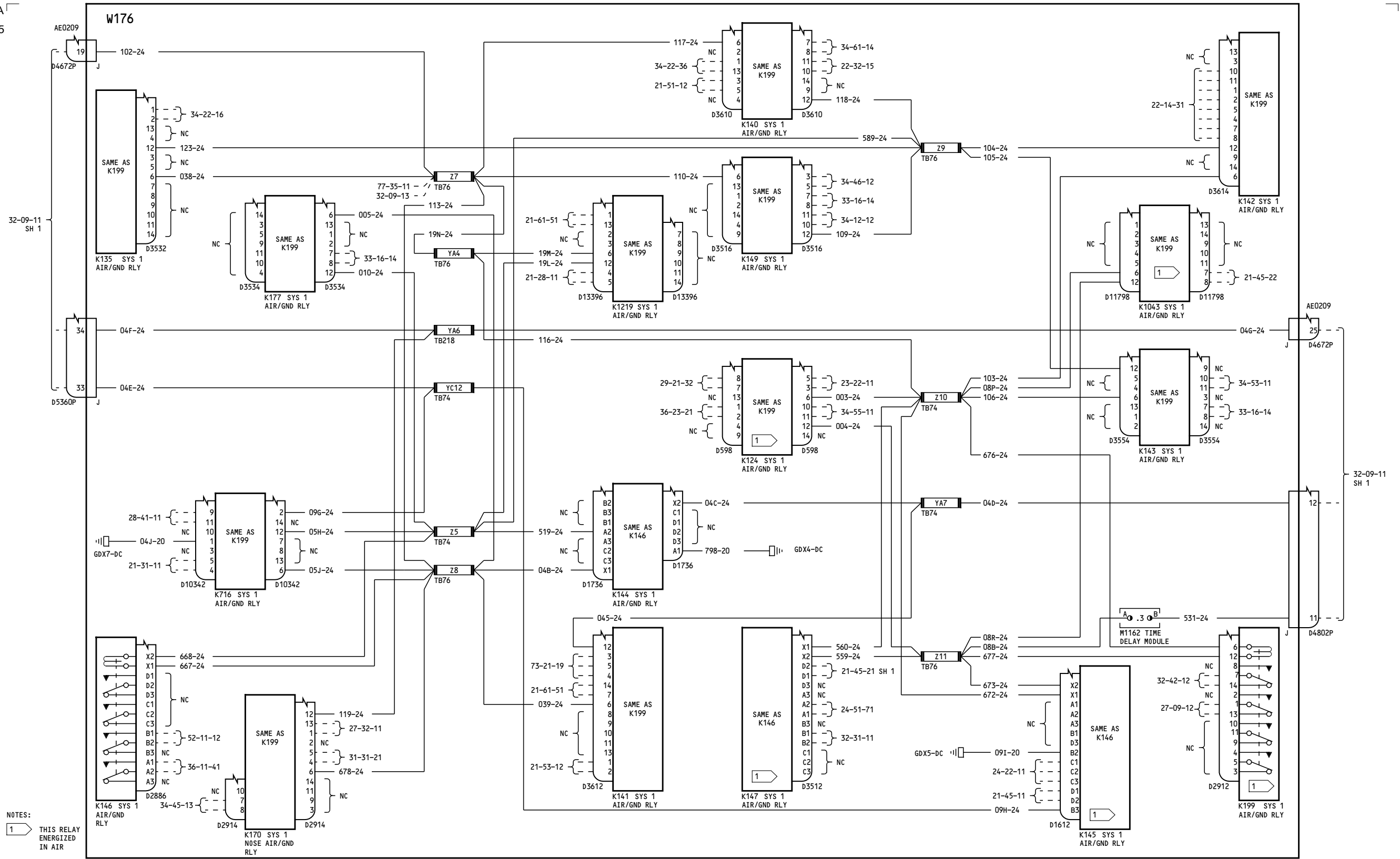

NOTES:  
1 THIS RELAY ENERGIZED IN AIR

275

**AIR/GROUND RELAYS-  
SYSTEM 1**

**32-09-11**

Page 6.1  
Sheet 2  
Jan 21/2005

D280T132

- Incorporates
- 21-0139 R01
- 25-0113 R04
- 78-0051FAA
- 78-0062 R04

**32-09-11**

Page 6.1  
Sheet 2  
Jan 21/2005

193

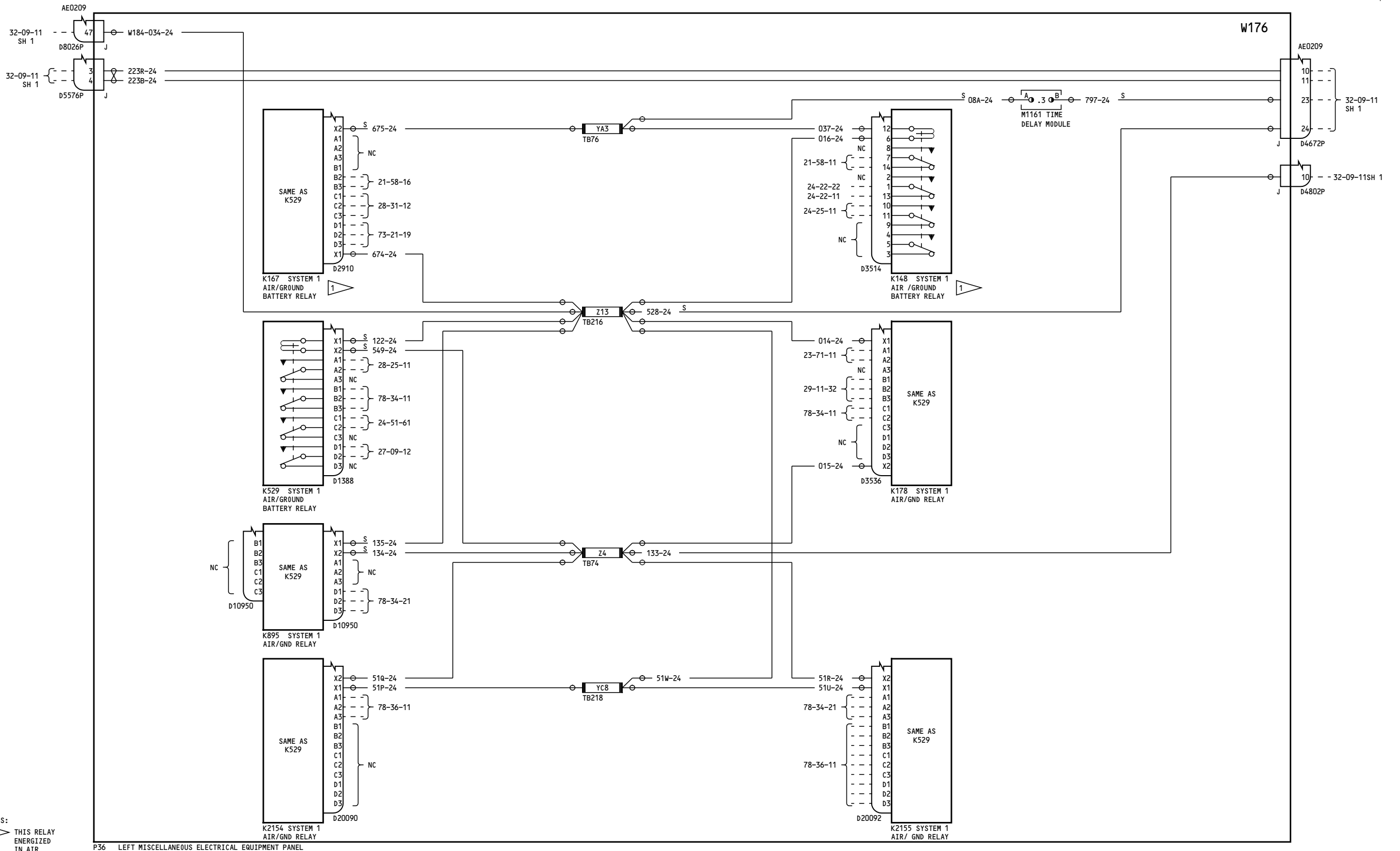

NOTES:  
 1 THIS RELAY ENERGIZED IN AIR

P36 LEFT MISCELLANEOUS ELECTRICAL EQUIPMENT PANEL

275

**AIR/GROUND RELAYS-  
SYSTEM 1**

**32-09-11**

Page 6.1  
 Sheet 3  
 Jan 21/2005

D280T132

Incorporates  
 78-0062 R04

**32-09-11**

Page 6.1  
 Sheet 3  
 Jan 21/2005

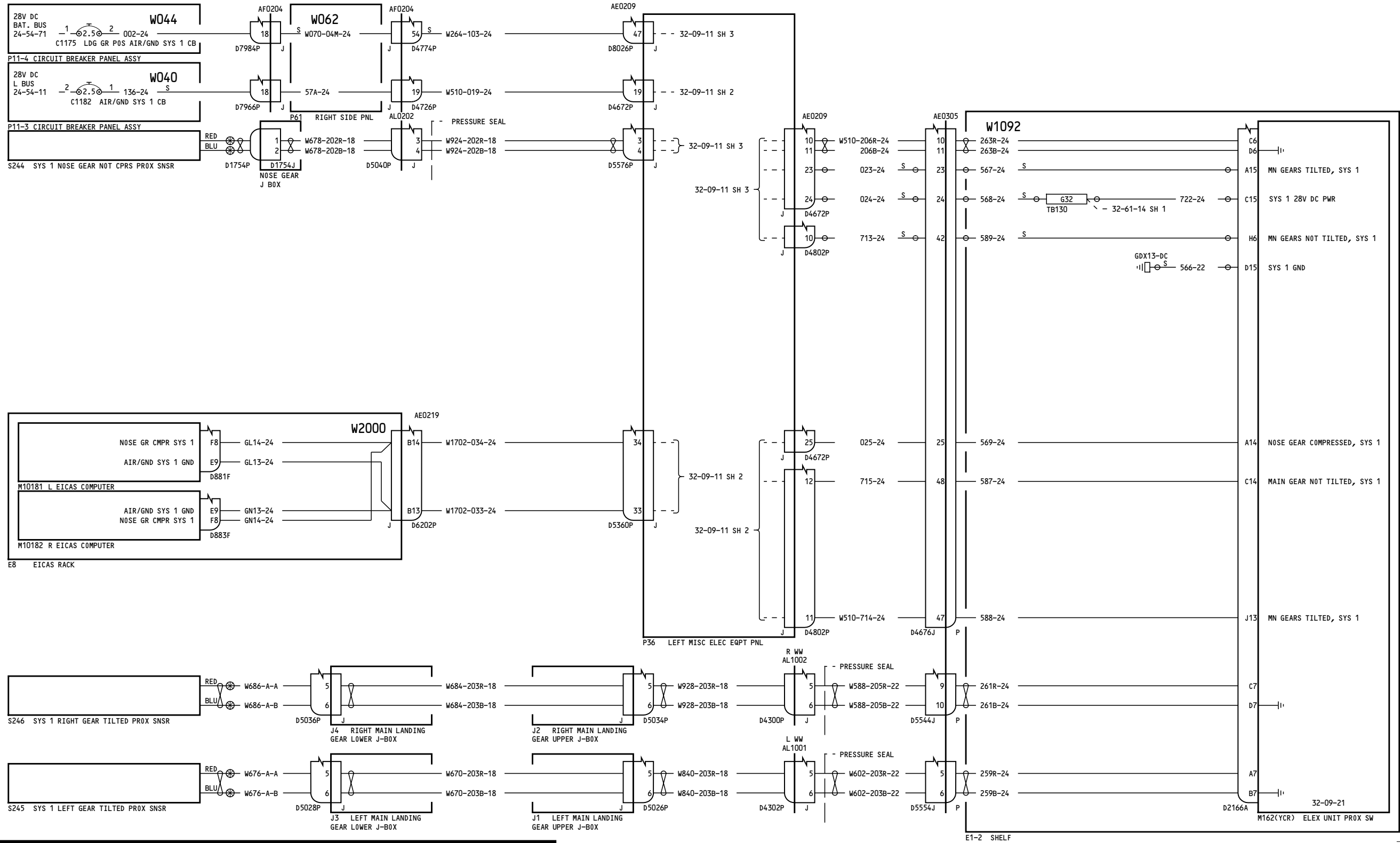

-A  
236

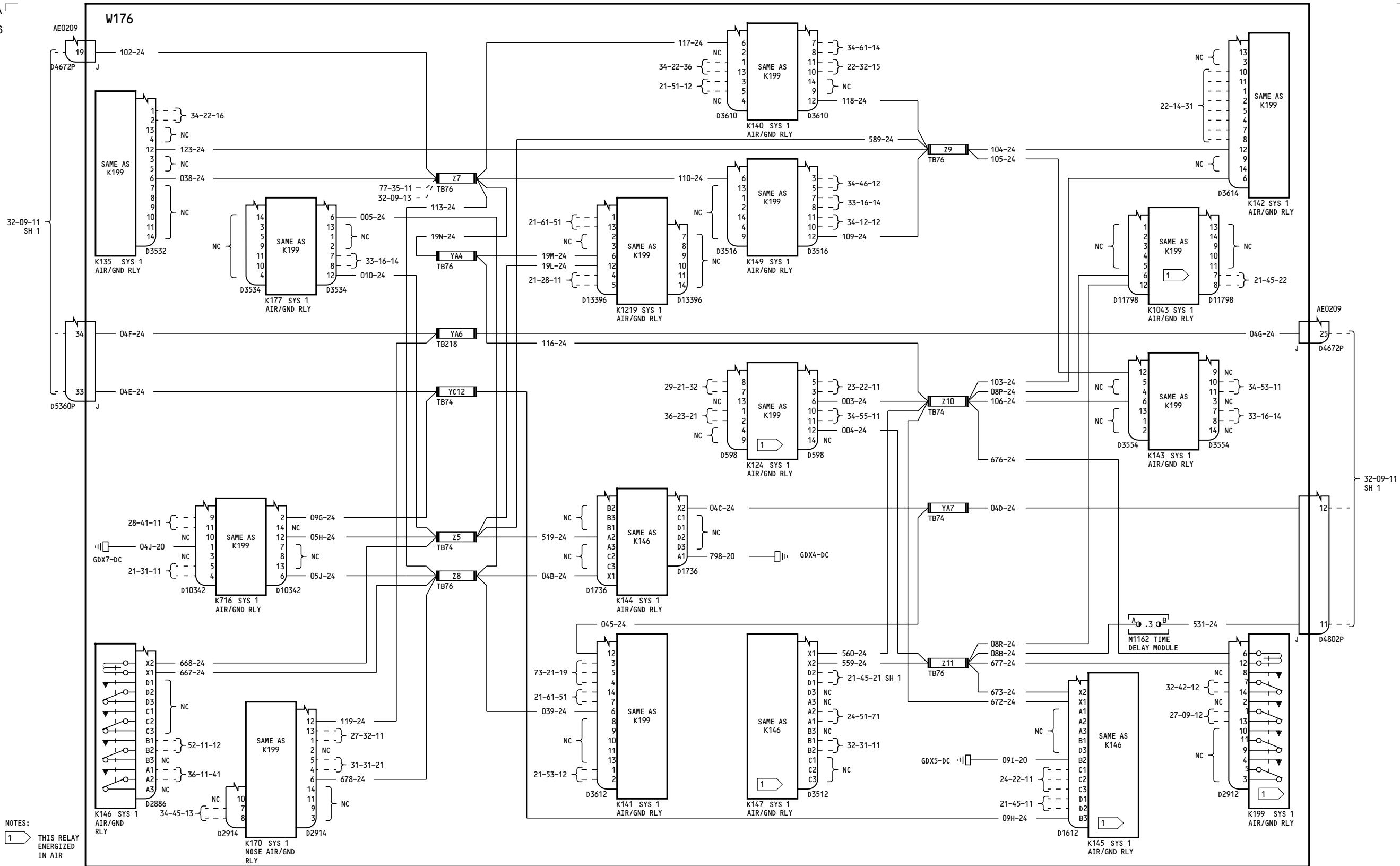

NOTES:  
 1 THIS RELAY ENERGIZED IN AIR

P36 LEFT MISC ELEC EQPT PNL

276

**AIR/GROUND RELAYS-  
SYSTEM 1**

D280T132

**32-09-11**

Page 7.1  
Sheet 2  
Jan 21/2005

Incorporates

- 21-0139 R01
- 78-0051FAA
- 78-0062 R04

**32-09-11**

Page 7.1  
Sheet 2  
Jan 21/2005

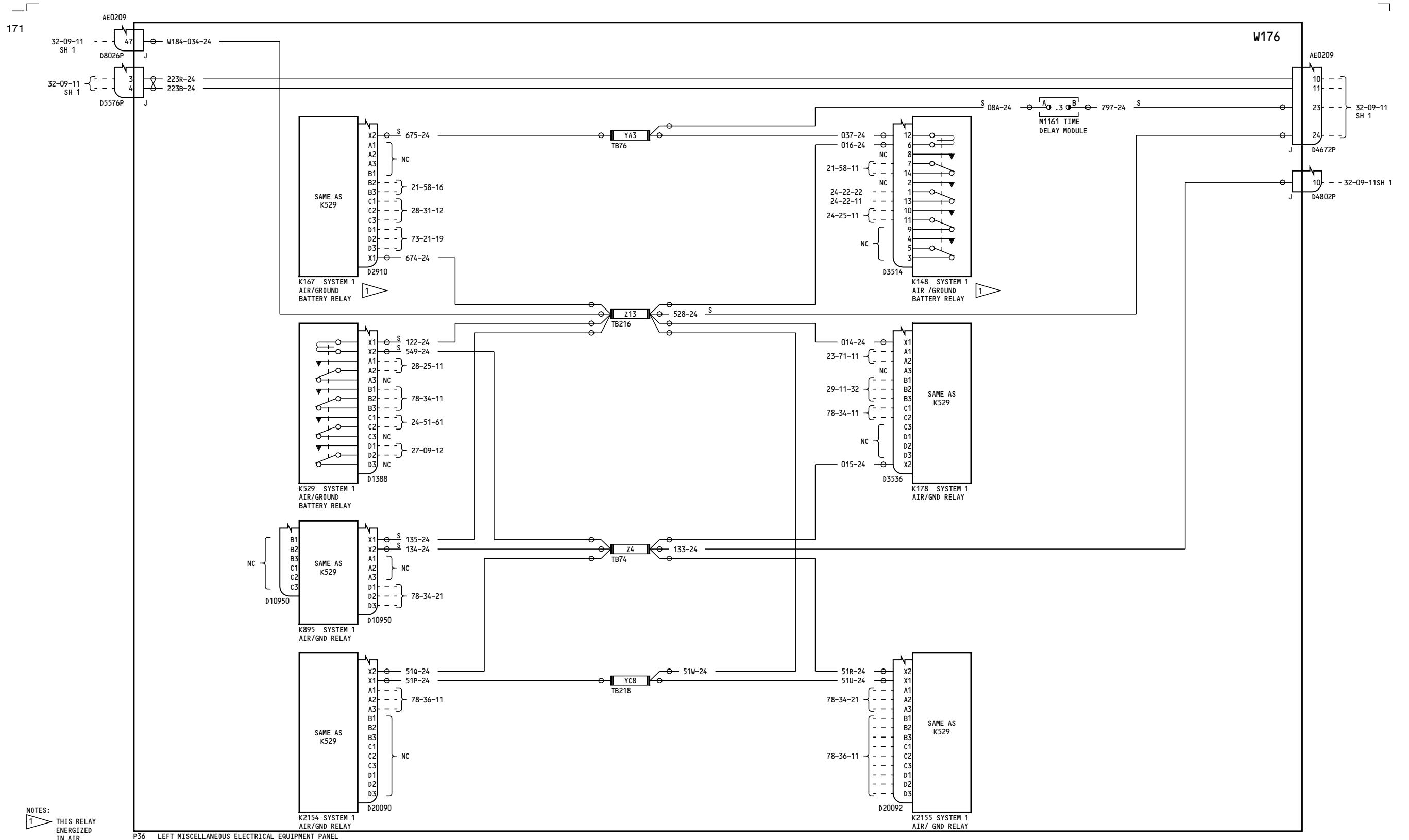

276

**AIR/GROUND RELAYS-  
SYSTEM 1**

**32-09-11**

Incorporates  
78-0062 R04

**32-09-11**

D280T132

Page 7.1  
Sheet 3  
Jan 21/2005

Page 7.1  
Sheet 3  
Jan 21/2005

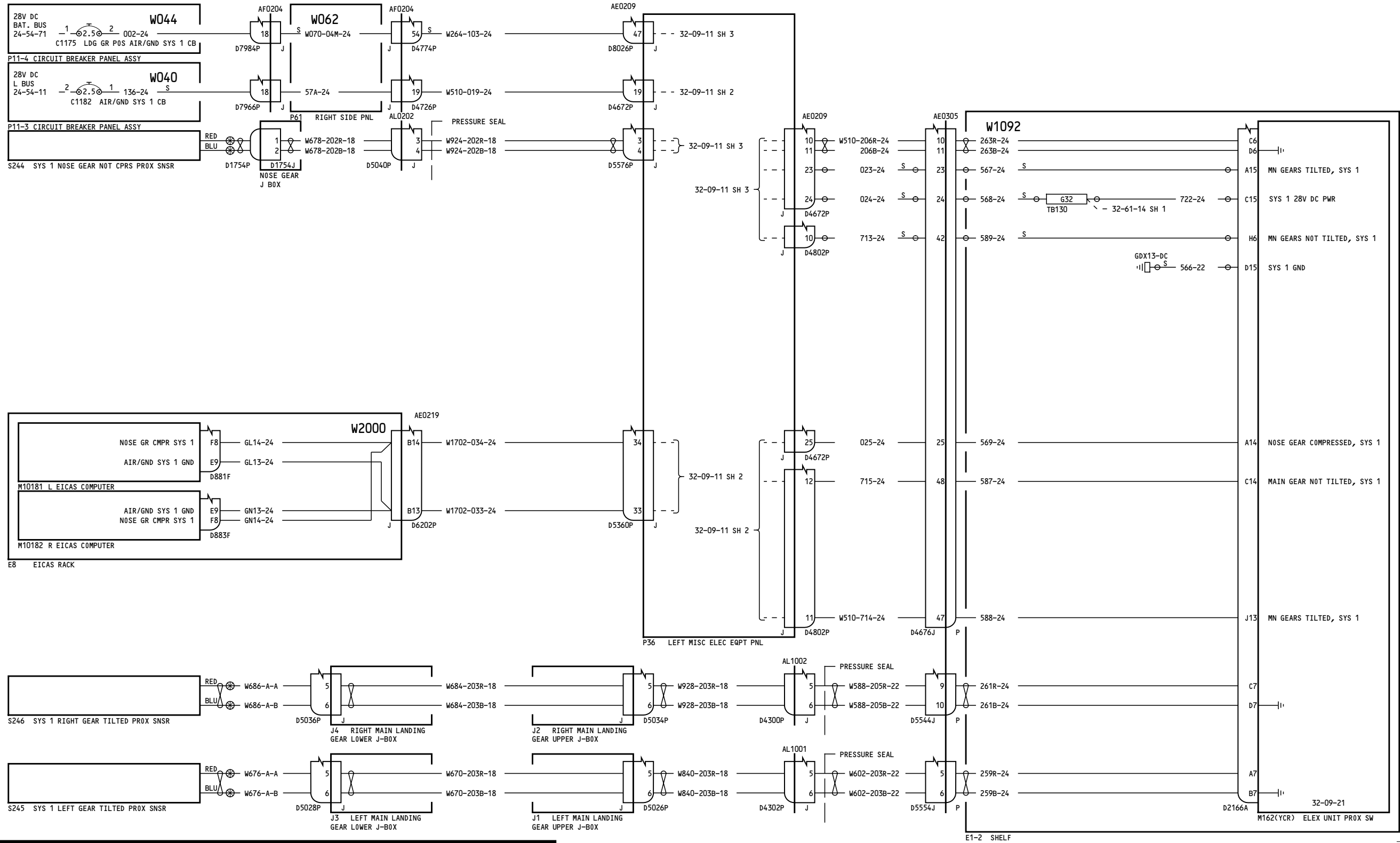

277-278

**AIR/GROUND RELAYS-  
SYSTEM 1**

D280T132

**32-09-11**

Page 8.1  
Sheet 1  
Jan 21/2005

**32-09-11**

Page 8.1  
Sheet 1  
Jan 21/2005



-A  
267

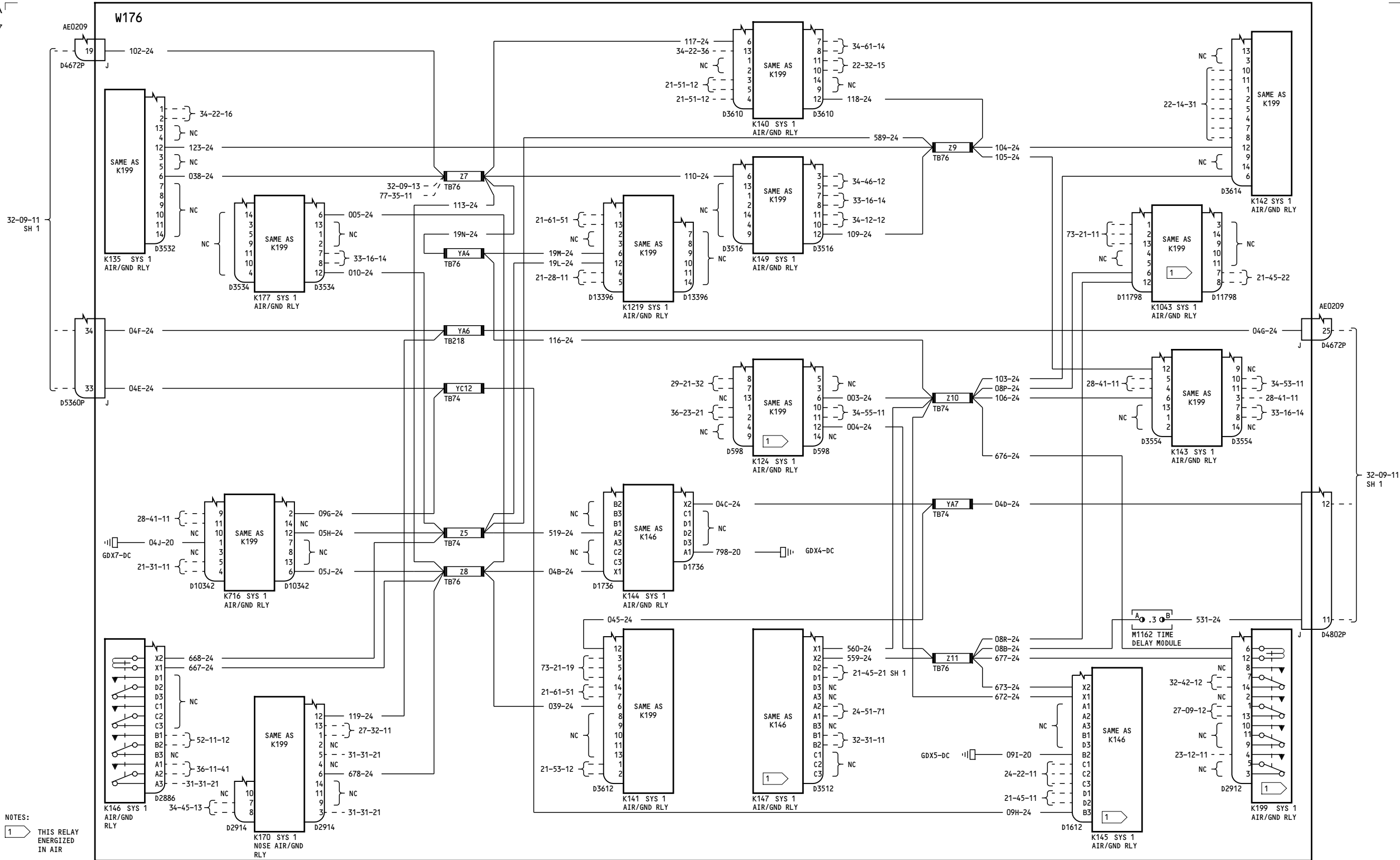

NOTES:  
 1 THIS RELAY ENERGIZED IN AIR

277-278  
 AIR/GROUND RELAYS-SYSTEM 1  
 D280T132

32-09-11  
 Page 8.1  
 Sheet 2  
 Jan 21/2005

Incorporates  
 21-0139 R01  
 78-0062 R04

32-09-11  
 Page 8.1  
 Sheet 2  
 Jan 21/2005

186

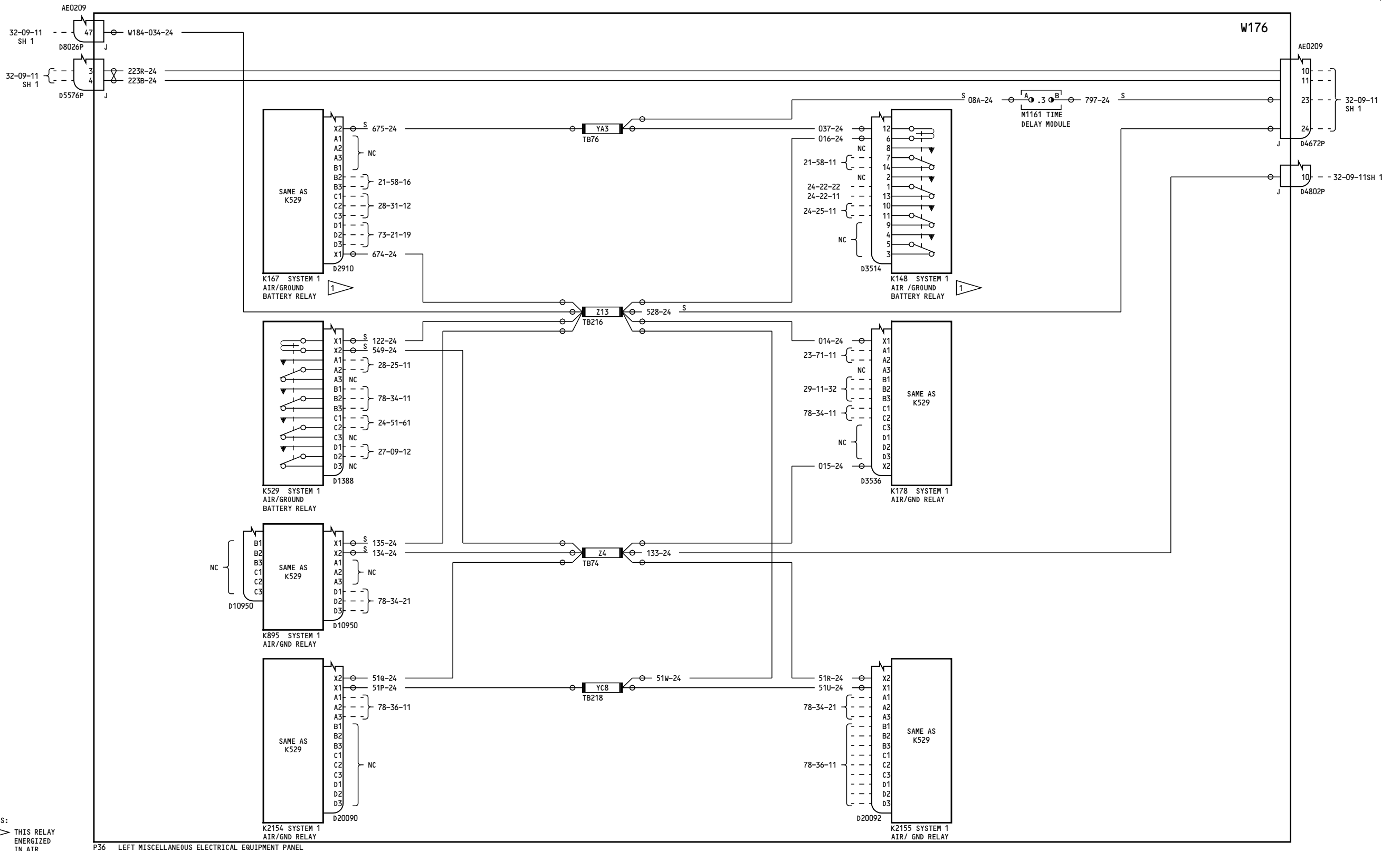

NOTES:  
 1 THIS RELAY ENERGIZED IN AIR

277-278

**AIR/GROUND RELAYS-  
SYSTEM 1**

D280T132

**32-09-11**

Page 8.1  
 Sheet 3  
 Jan 21/2005

Incorporates  
 78-0062 R04

**32-09-11**

Page 8.1  
 Sheet 3  
 Jan 21/2005

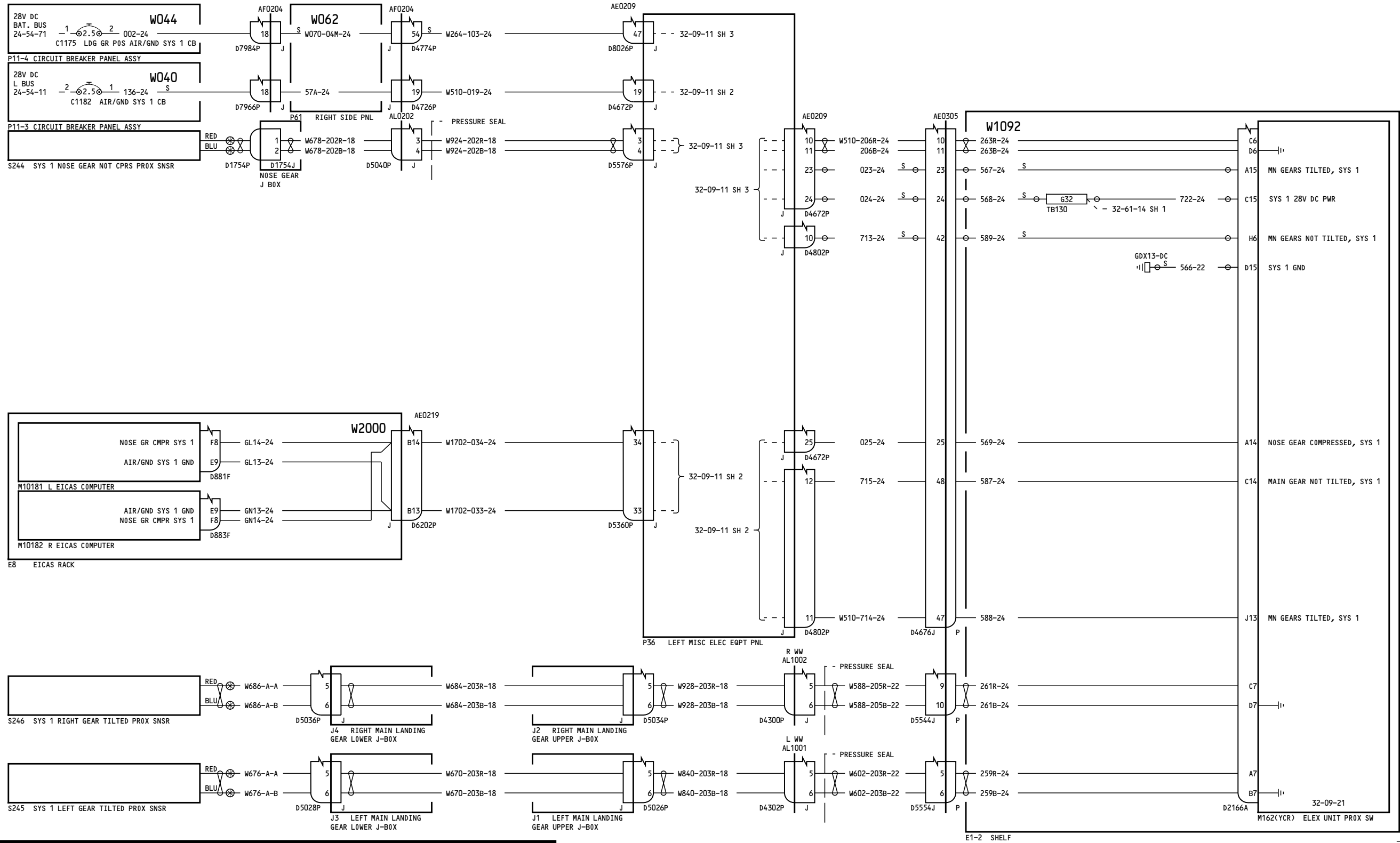

-A  
195

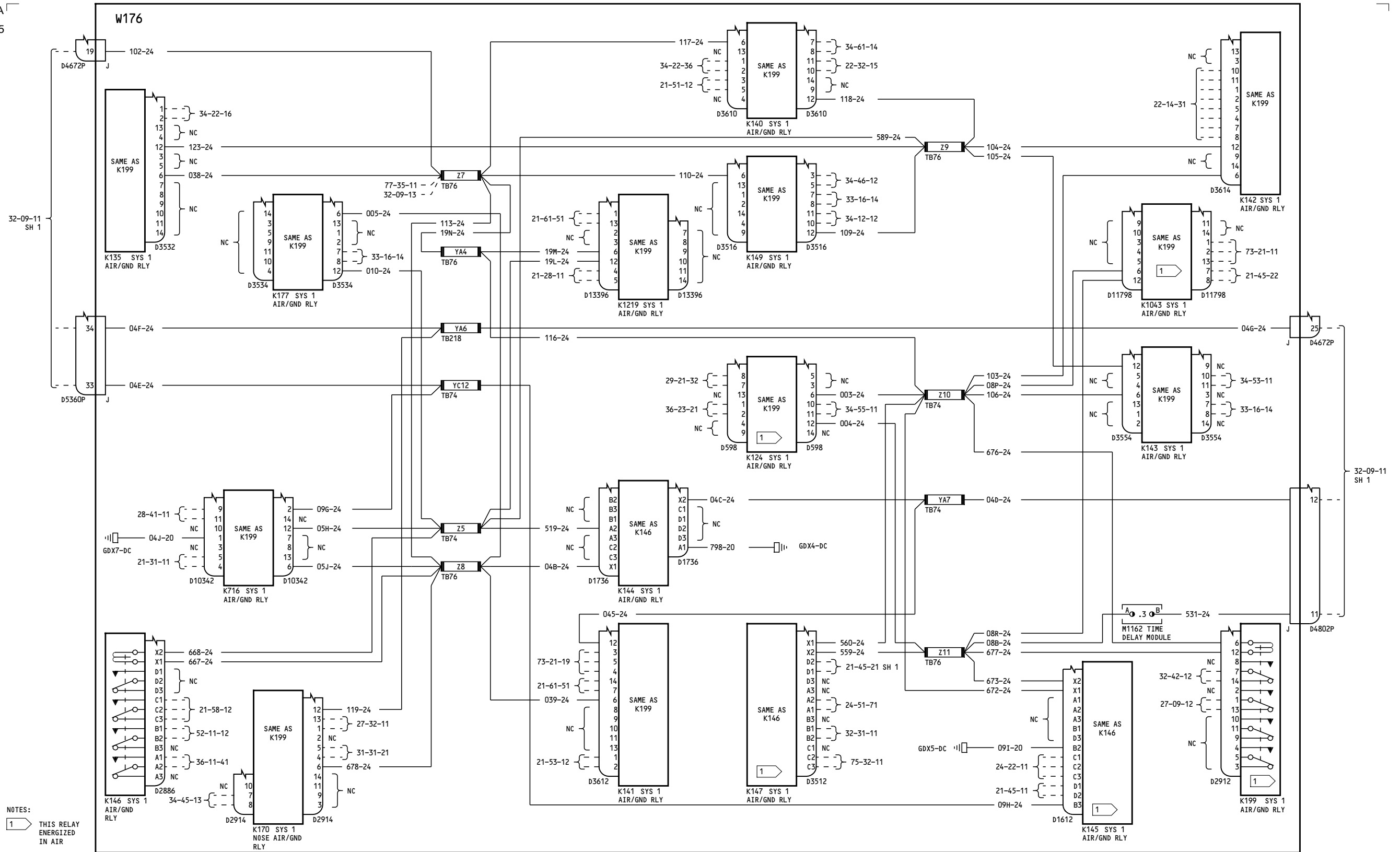

NOTES:  
1 THIS RELAY ENERGIZED IN AIR

P36 LEFT MISC ELEC EQPT PNL

280

AIR/GROUND RELAYS-  
SYSTEM 1

D280T132

32-09-11

Page 9.1  
Sheet 2  
Jan 21/2005

Incorporates  
21-0139 R01  
78-0062 R04

BOEING PROPRIETARY - Copyright © - Unpublished Work - See title page for details.

32-09-11

Page 9.1  
Sheet 2  
Jan 21/2005

187

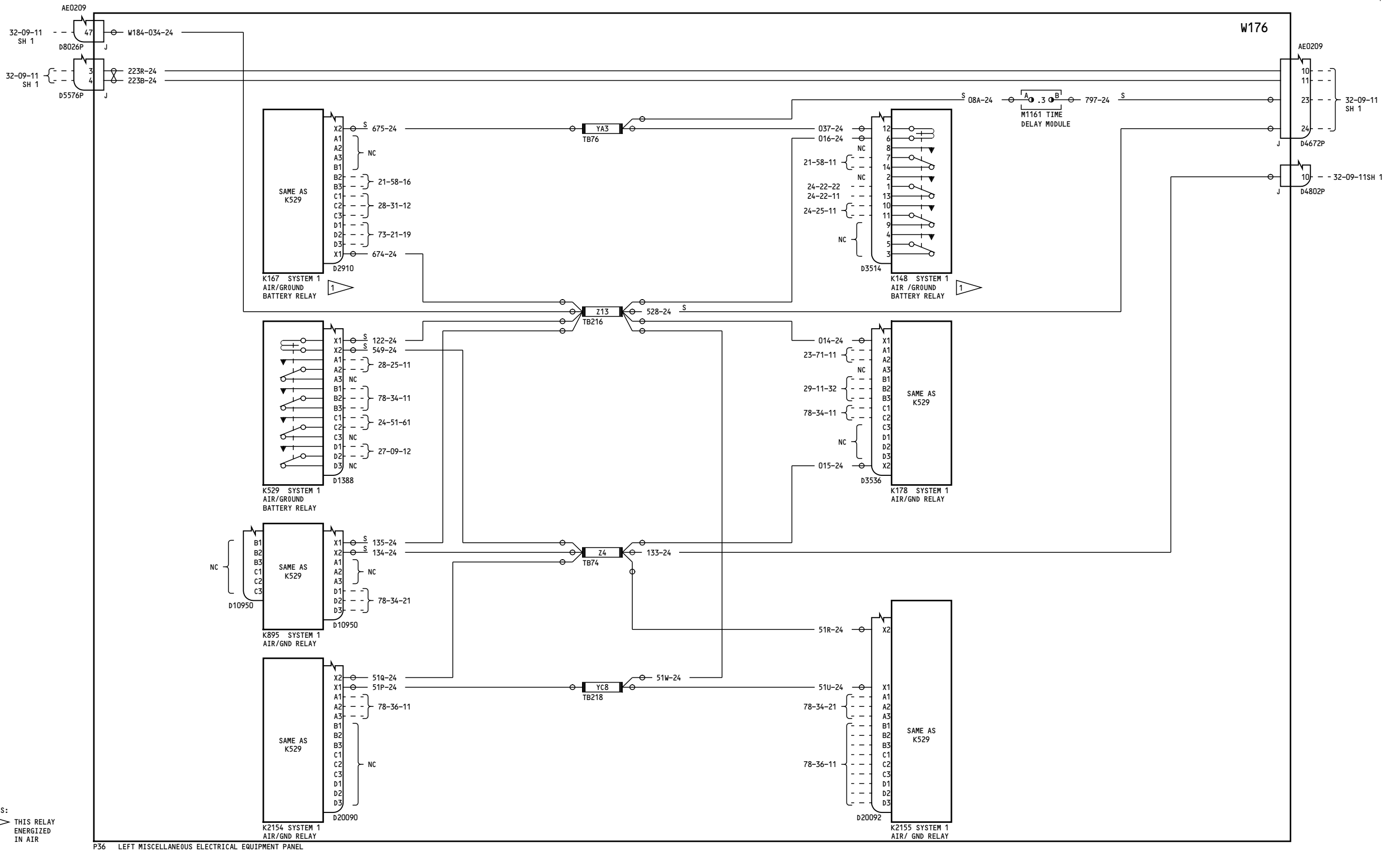

NOTES:  
 1 THIS RELAY ENERGIZED IN AIR

P36 LEFT MISCELLANEOUS ELECTRICAL EQUIPMENT PANEL

280

**AIR/GROUND RELAYS-  
SYSTEM 1**

**32-09-11**

Page 9.1  
 Sheet 3  
 Jan 21/2005

D280T132

Incorporates  
 78-0062 R04

**32-09-11**

Page 9.1  
 Sheet 3  
 Jan 21/2005

215

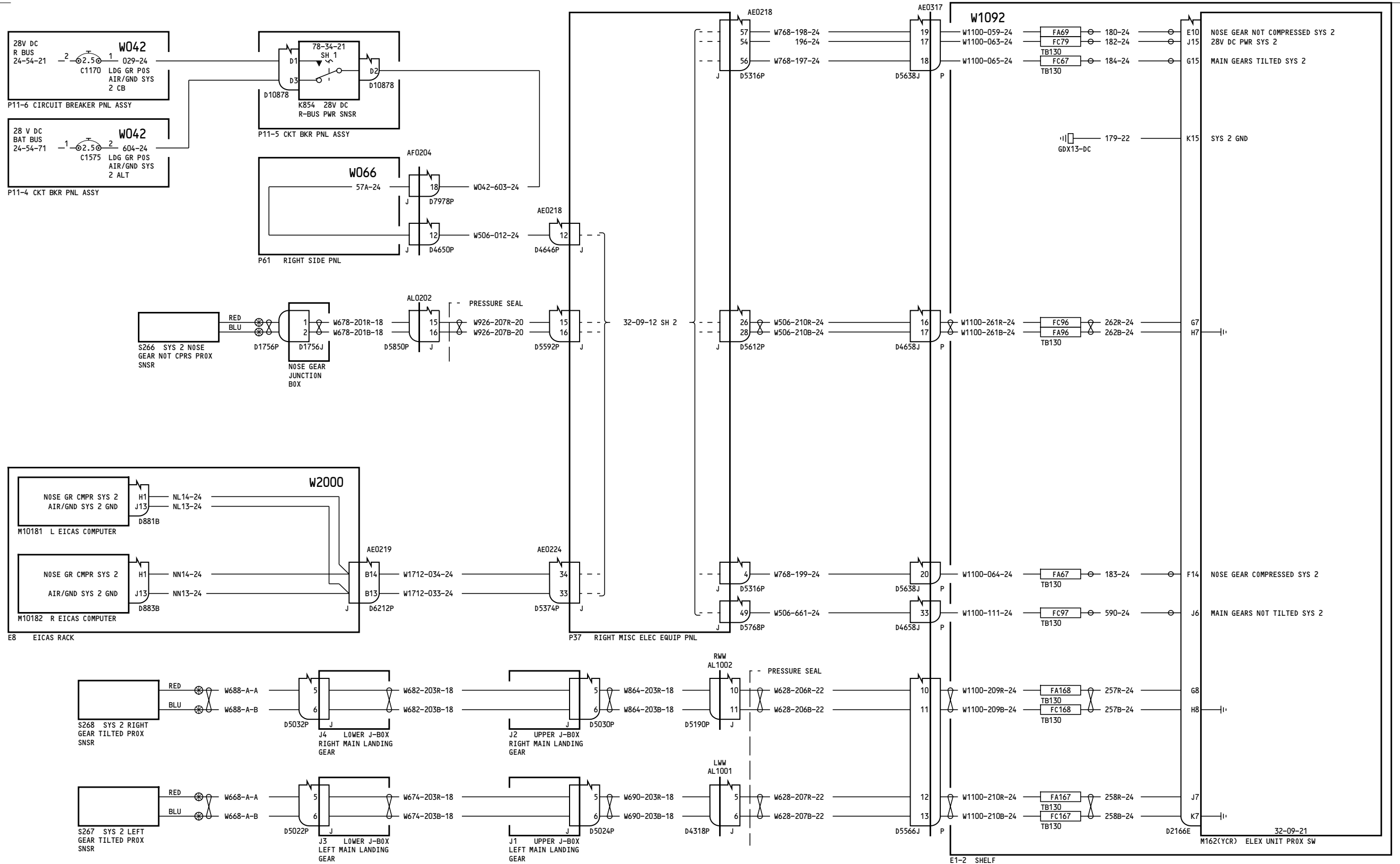

050-051

AIR/GROUND RELAYS-SYSTEM 2

D280T132

32-09-12

Page 1.1  
Sheet 1  
Jan 21/2005

Incorporates  
78-0051FAA

32-09-12

Page 1.1  
Sheet 1  
Jan 21/2005

271

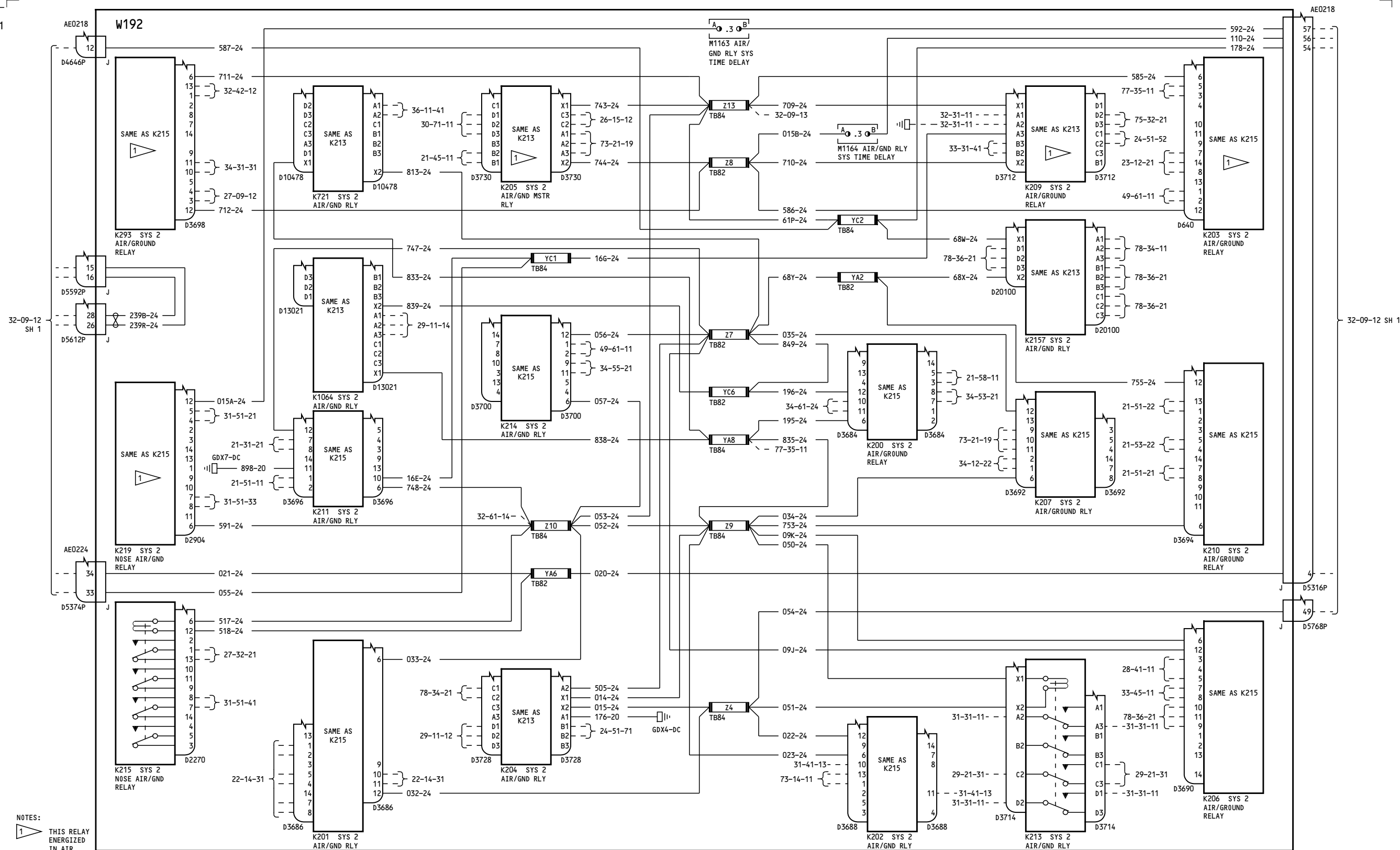

NOTES:  
 1 THIS RELAY ENERGIZED IN AIR

050-051  
 P37 RIGHT MISC. ELEC. EQPT. PNL  
**AIR/GROUND RELAYS- SYSTEM 2**  
 D280T132

32-09-12

Page 1.1  
Sheet 2  
Jan 21/2005

Incorporates  
 78-0051FAA  
 78-0062 R04

32-09-12

Page 1.1  
Sheet 2  
Jan 21/2005

227

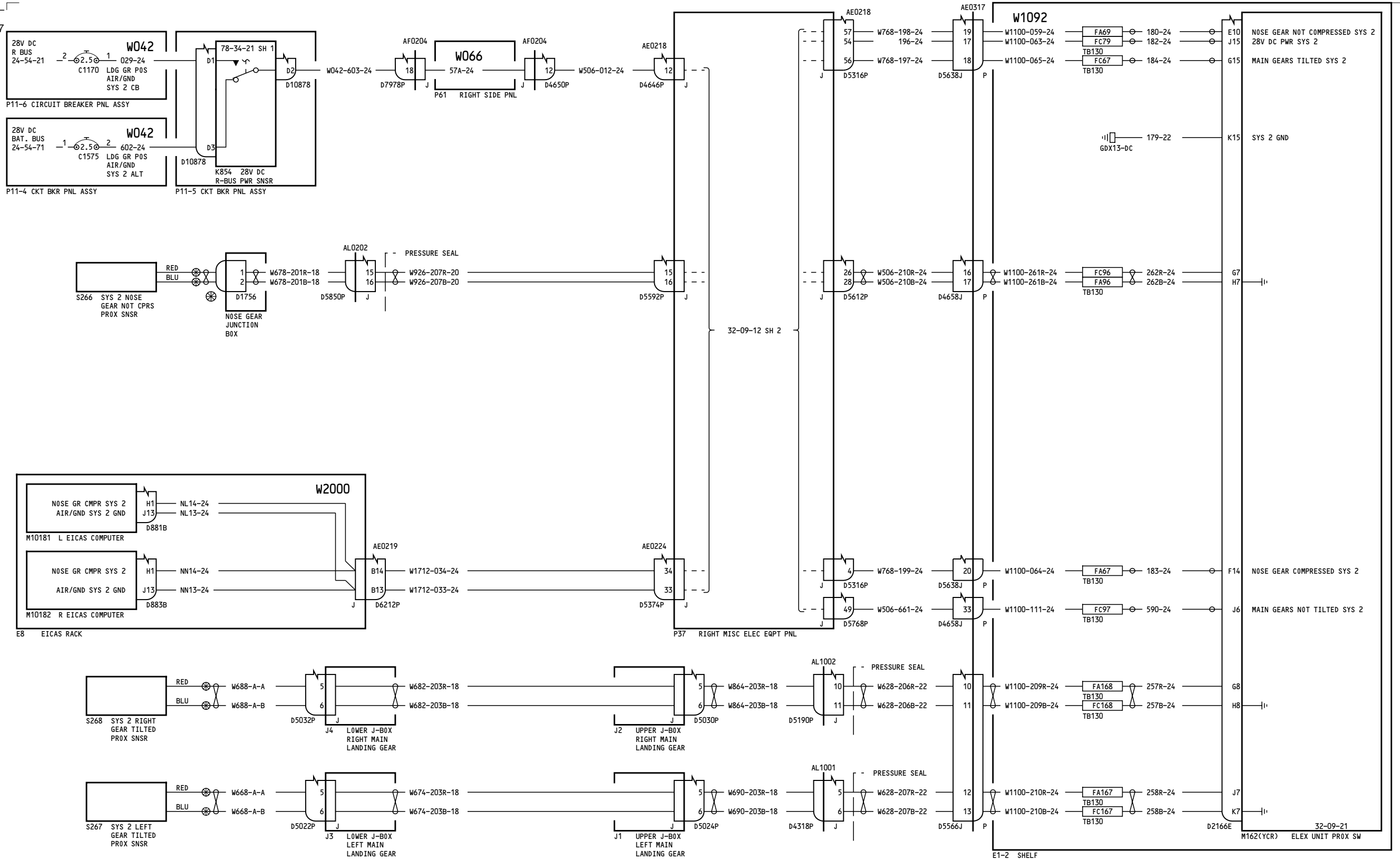

150-156, 275-276

**AIR/GROUND RELAYS-SYSTEM 2**

D280T132

**32-09-12**

Page 2.1  
Sheet 1  
Jan 21/2005

Incorporates  
78-0051FAA

**32-09-12**

Page 2.1  
Sheet 1  
Jan 21/2005



277

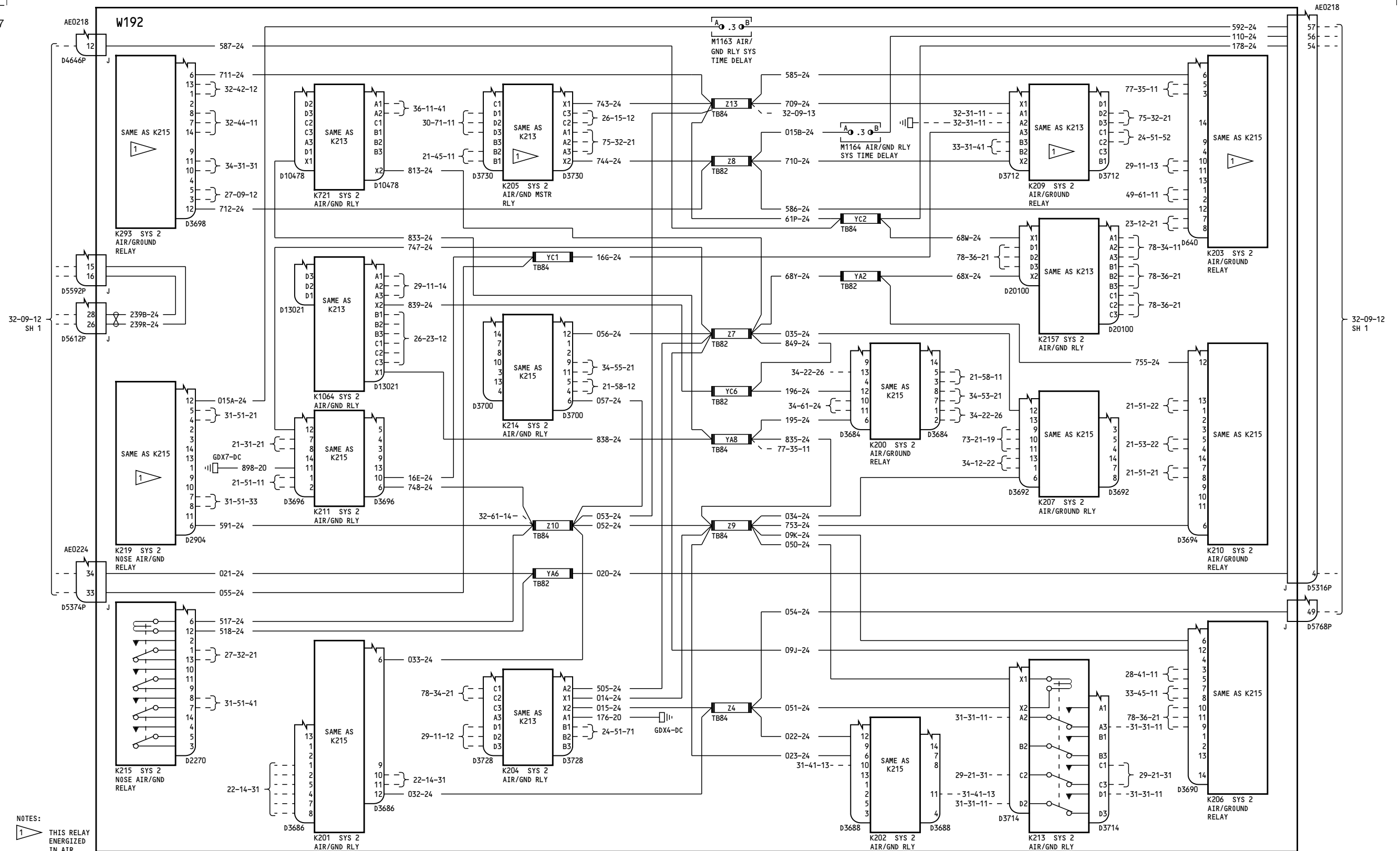

150-156, 275-276

**AIR/GROUND RELAYS-  
SYSTEM 2**

**32-09-12**

Incorporates  
78-0051FAA  
78-0062 R04

**32-09-12**

D280T132

Page 2.1  
Sheet 2  
Jan 21/2005

Page 2.1  
Sheet 2  
Jan 21/2005

196

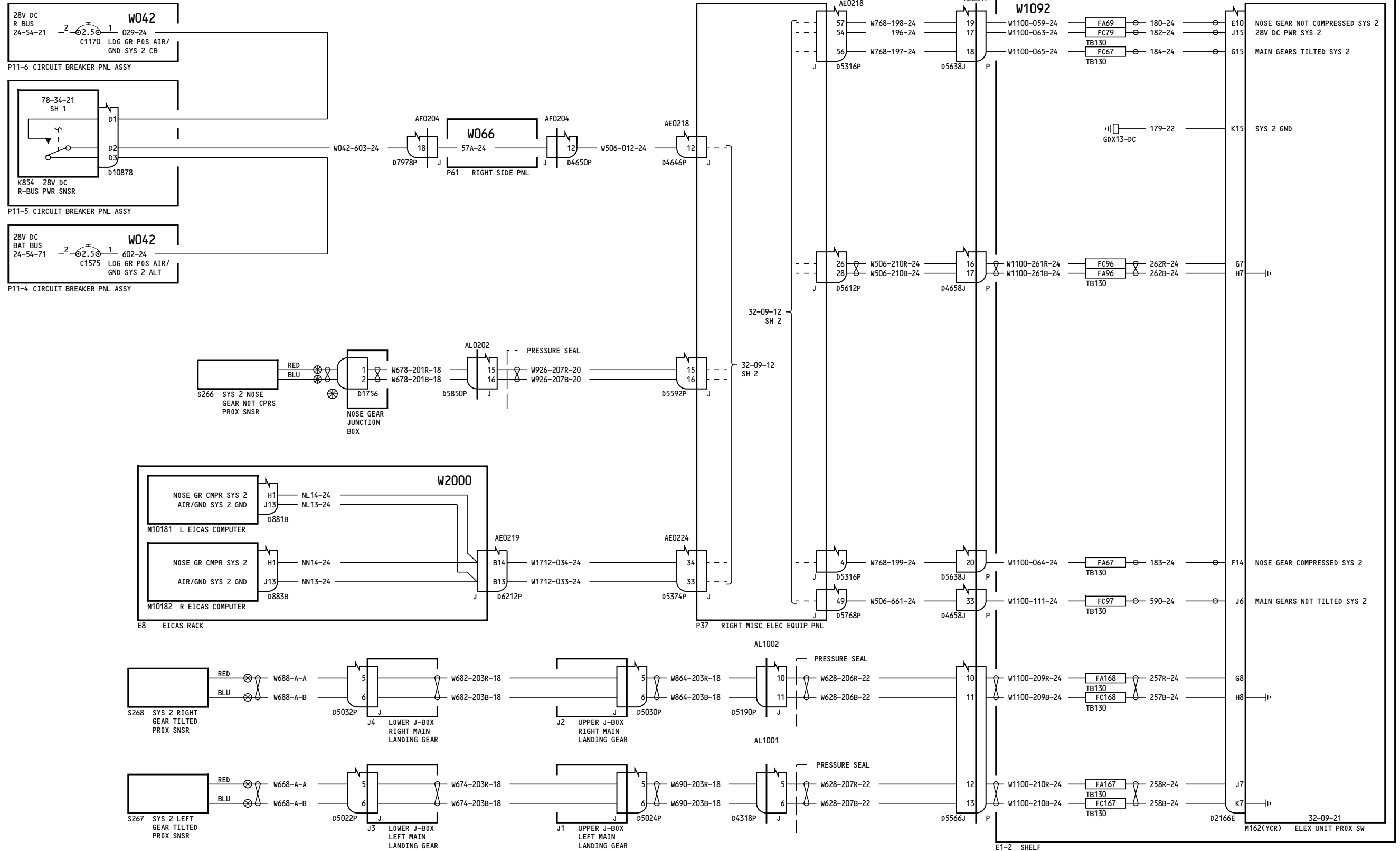

157

AIR/GROUND RELAYS-SYSTEM 2

32-09-12

Page 3.1  
Sheet 1  
Jan 21/2005

D280T132

32-09-12

Page 3.1  
Sheet 1  
Jan 21/2005

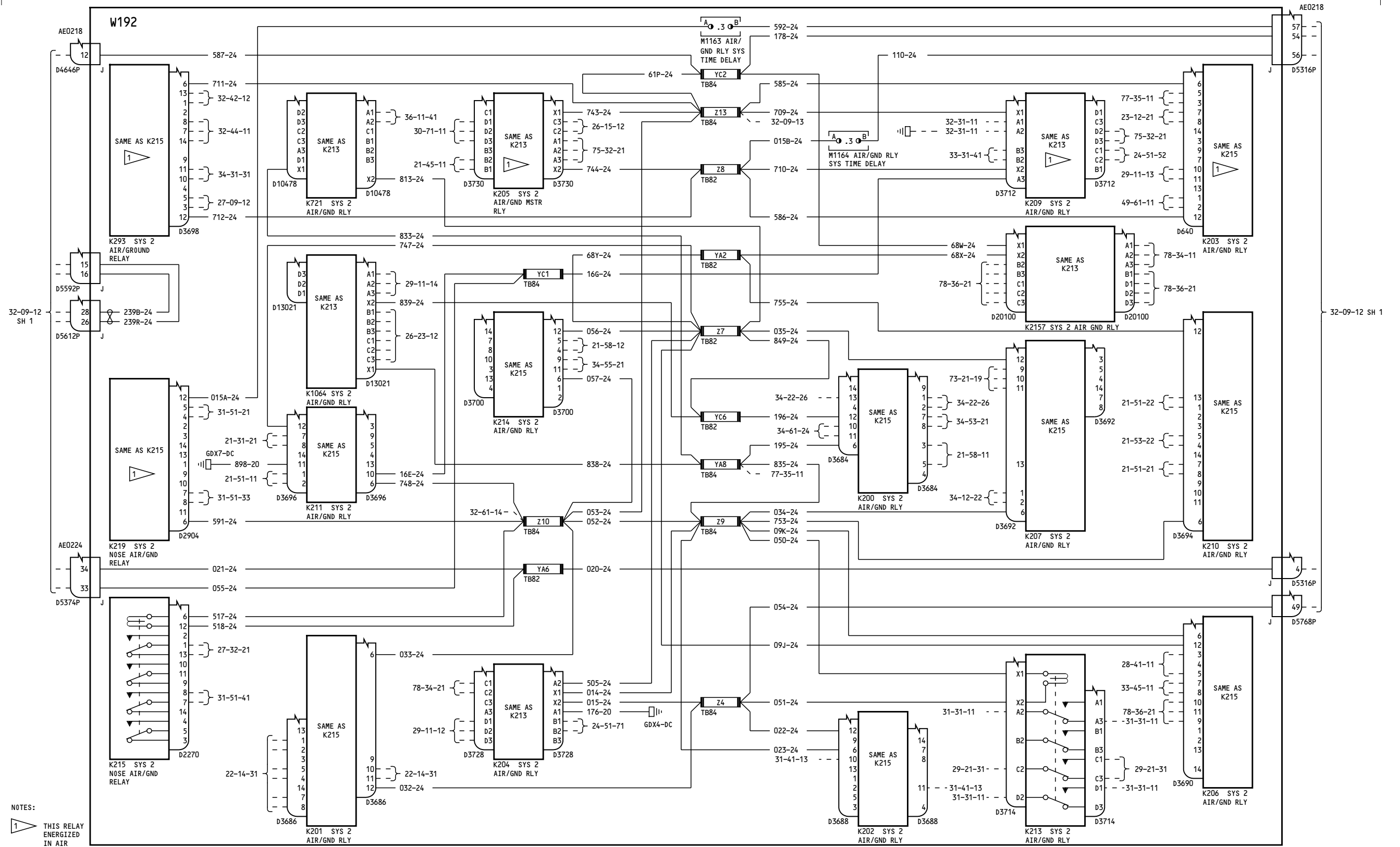

214

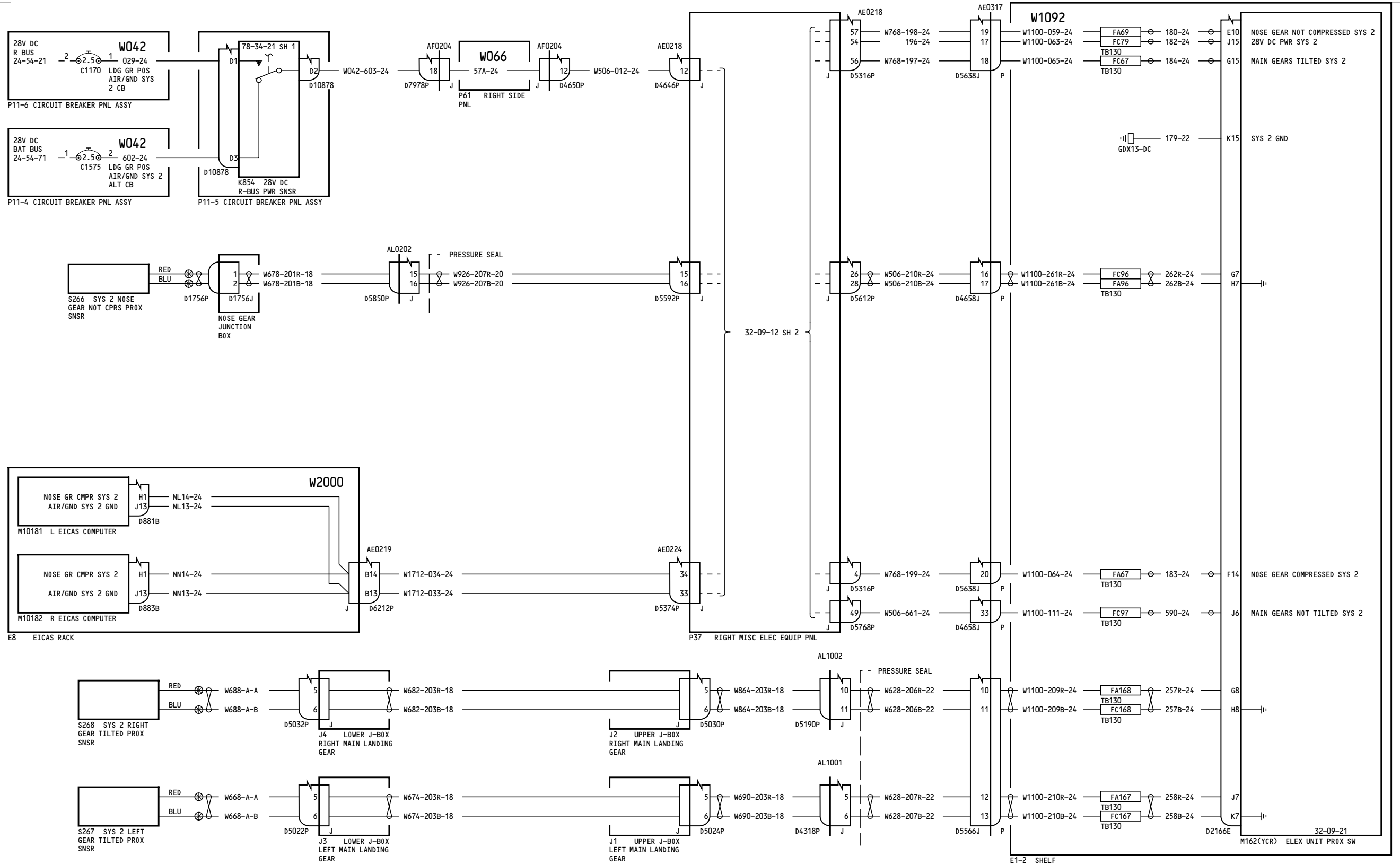

162-166

**AIR/GROUND RELAYS-SYSTEM 2**

D280T132

**32-09-12**

Page 4.1  
Sheet 1  
Jan 21/2005

Incorporates  
78-0051FAA

**32-09-12**

Page 4.1  
Sheet 1  
Jan 21/2005

270

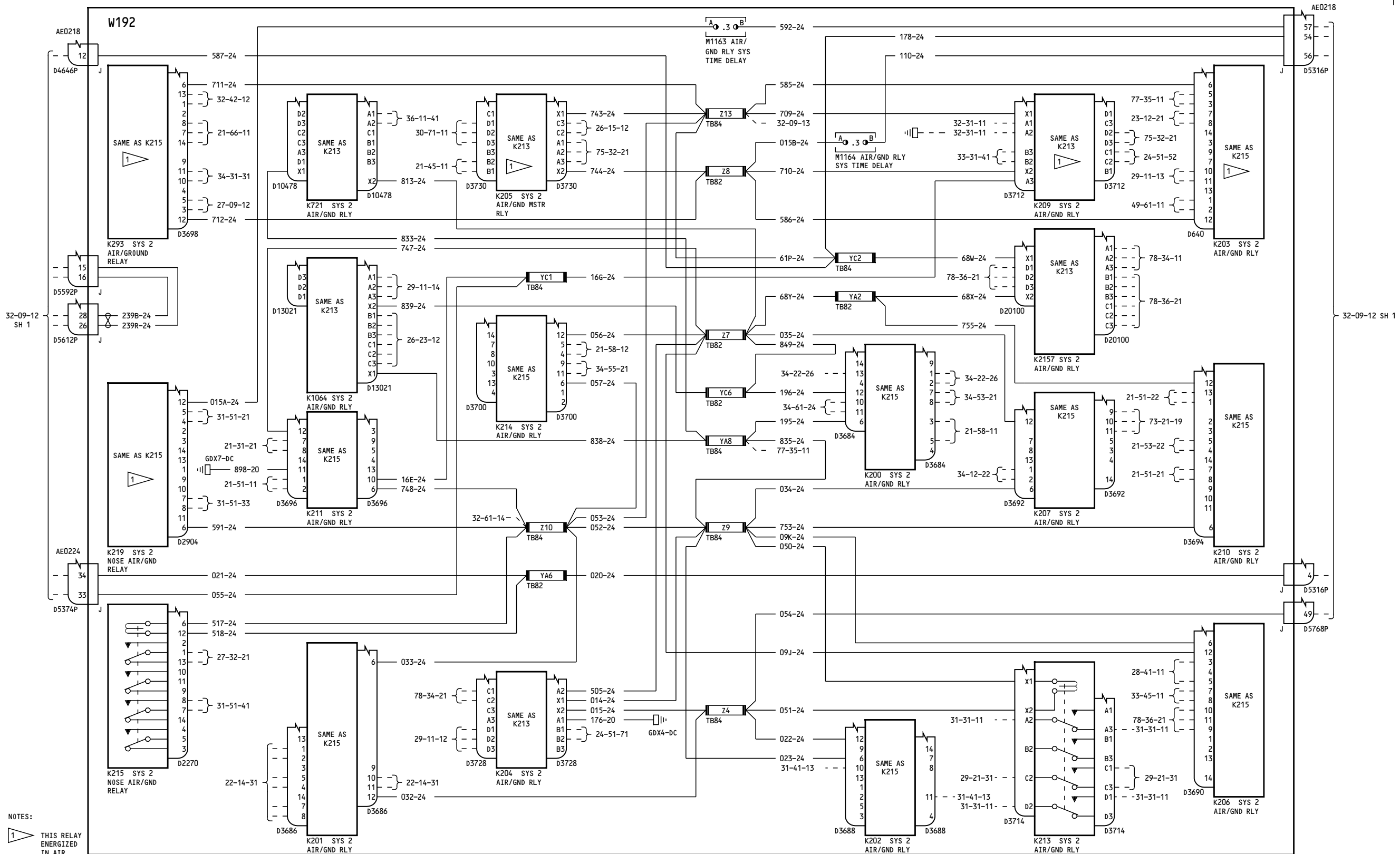

NOTES:  
1 THIS RELAY ENERGIZED IN AIR

162-166

**AIR/GROUND RELAYS-  
SYSTEM 2**

D280T132

**32-09-12**

Page 4.1  
Sheet 2  
Jan 21/2005

Incorporates  
78-0051FAA  
78-0062 R04

**32-09-12**

Page 4.1  
Sheet 2  
Jan 21/2005

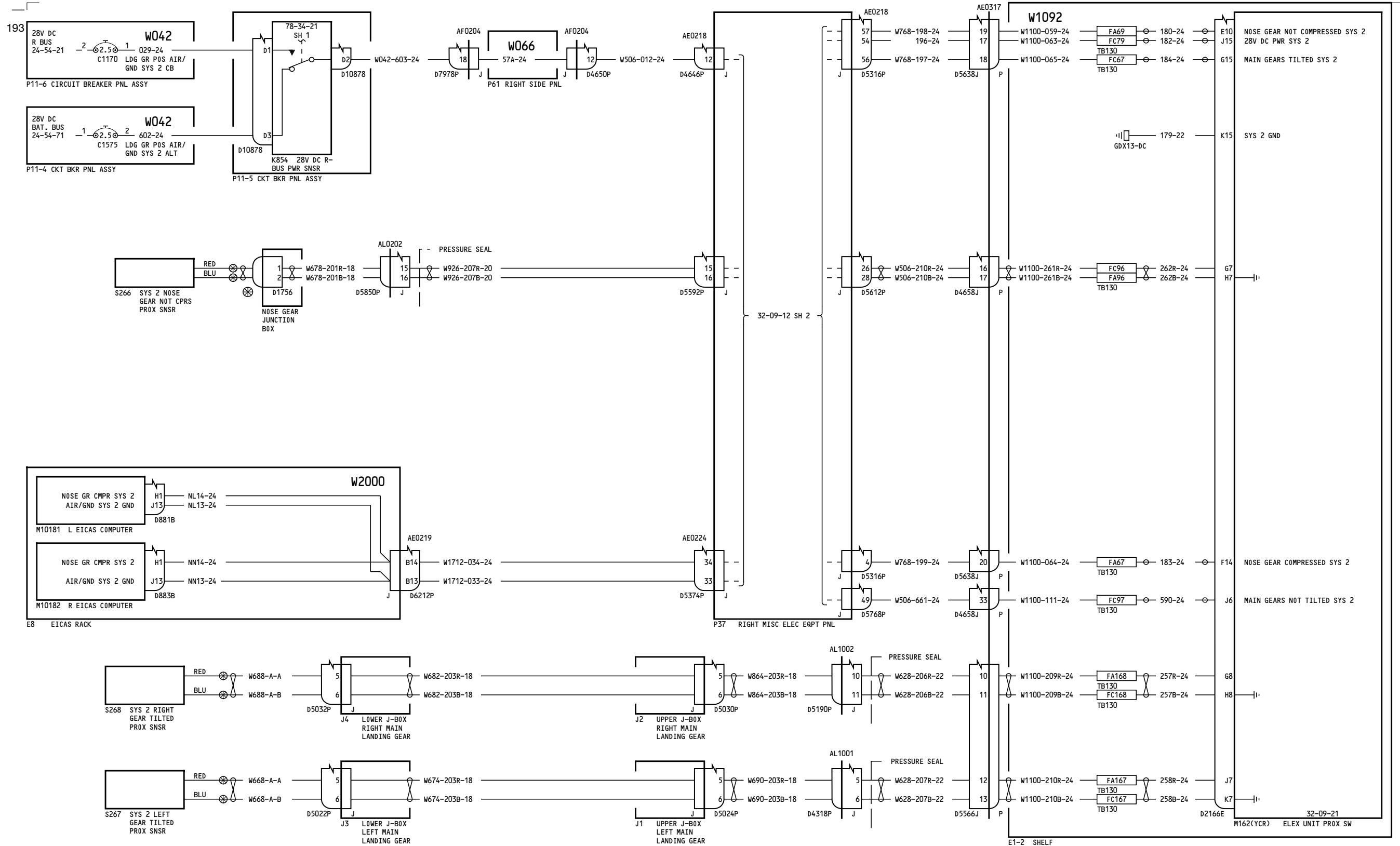

167

**AIR/GROUND RELAYS-SYSTEM 2**

D280T132

**32-09-12**

Page 5.1  
Sheet 1  
Jan 21/2005

**32-09-12**

Page 5.1  
Sheet 1  
Jan 21/2005

240

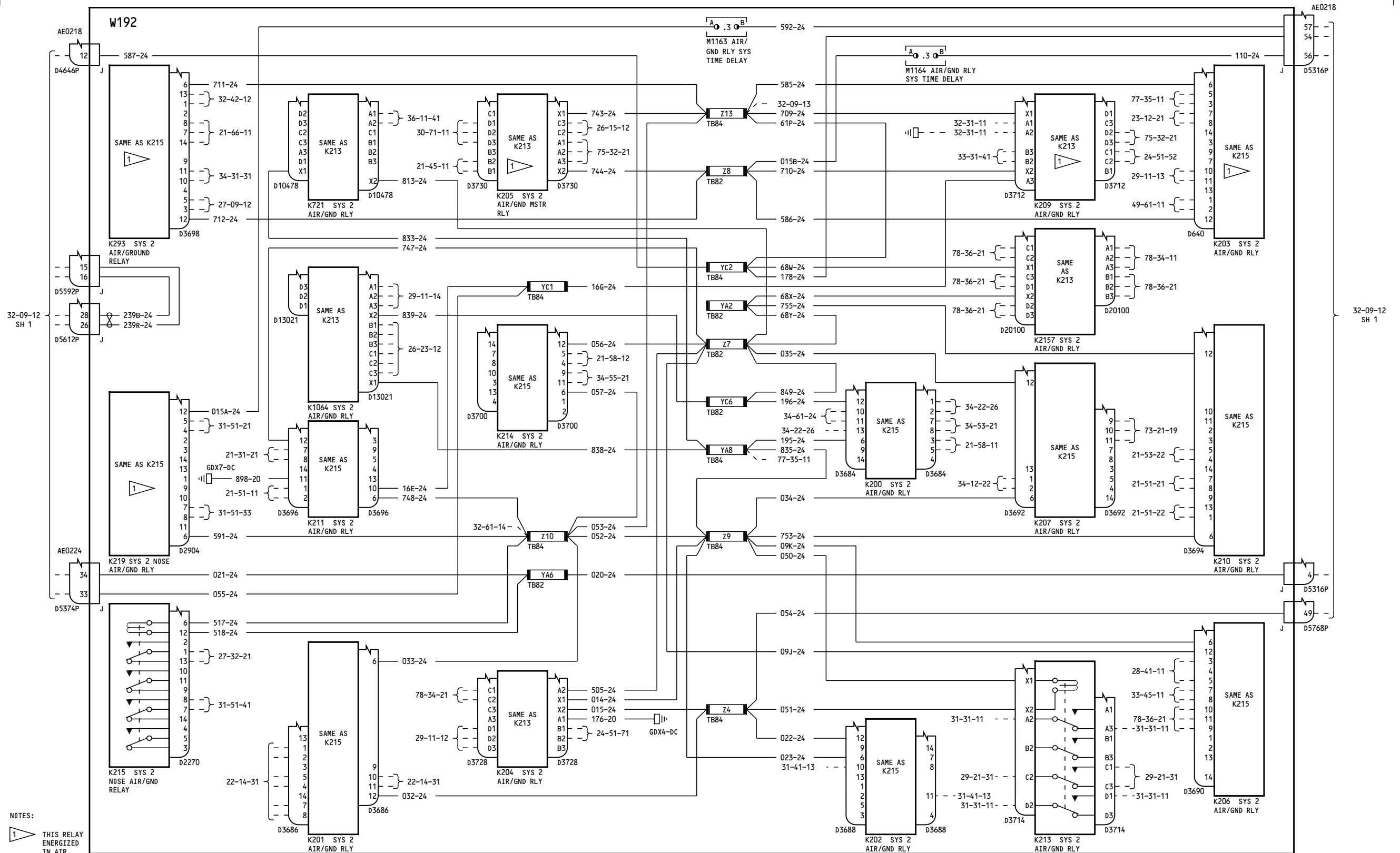

NOTES:  
 1 THIS RELAY ENERGIZED IN AIR

167

**AIR/GROUND RELAYS- SYSTEM 2**

D280T132

**32-09-12**

Page 5.1  
 Sheet 2  
 Jan 21/2005

Incorporates  
 78-0062 R04

**32-09-12**

Page 5.1  
 Sheet 2  
 Jan 21/2005

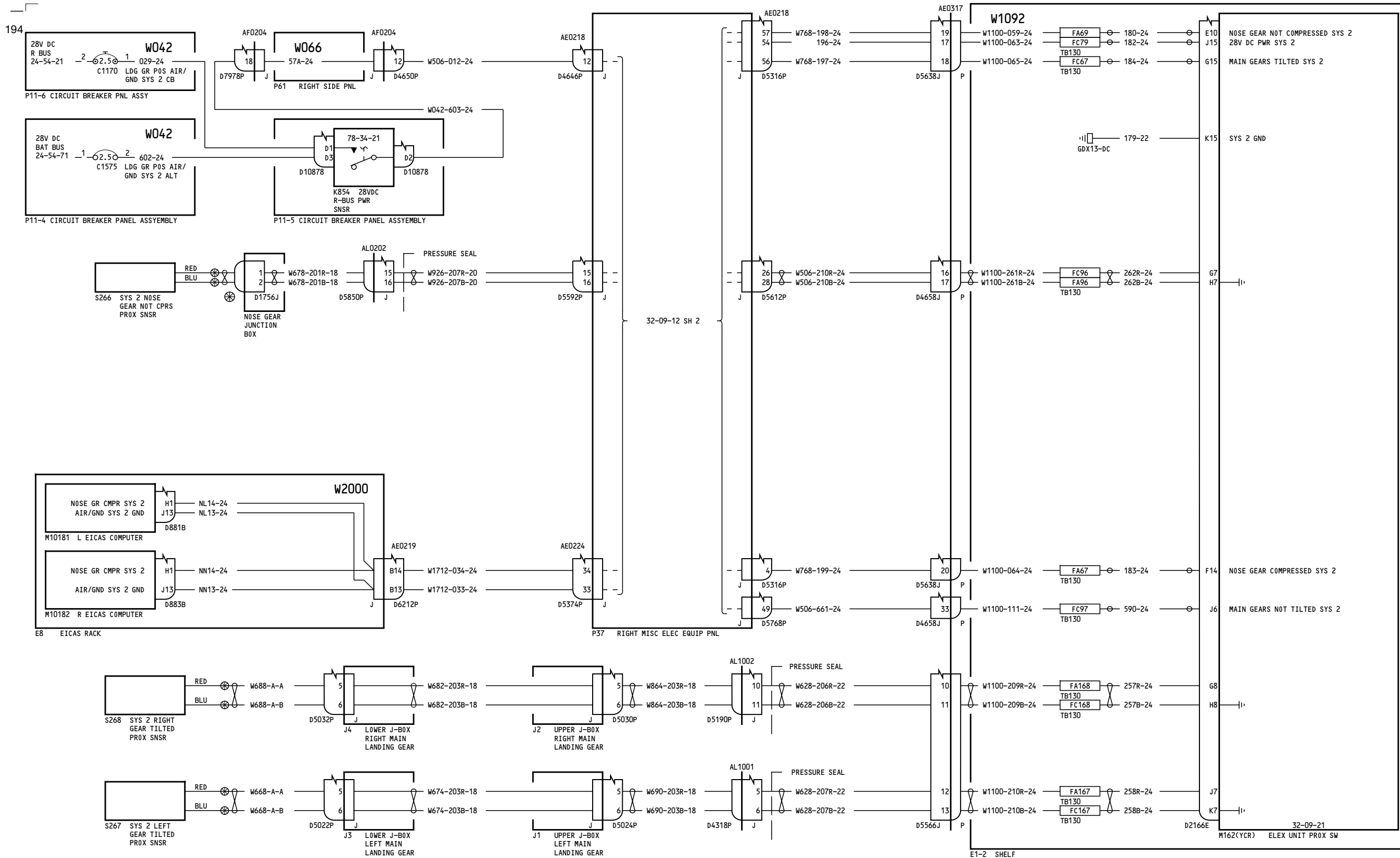

277-278

**AIR/GROUND RELAYS-  
SYSTEM 2**

D280T132

**32-09-12**

Page 6.1  
Sheet 1  
Jan 21/2005

**32-09-12**

Page 6.1  
Sheet 1  
Jan 21/2005



243

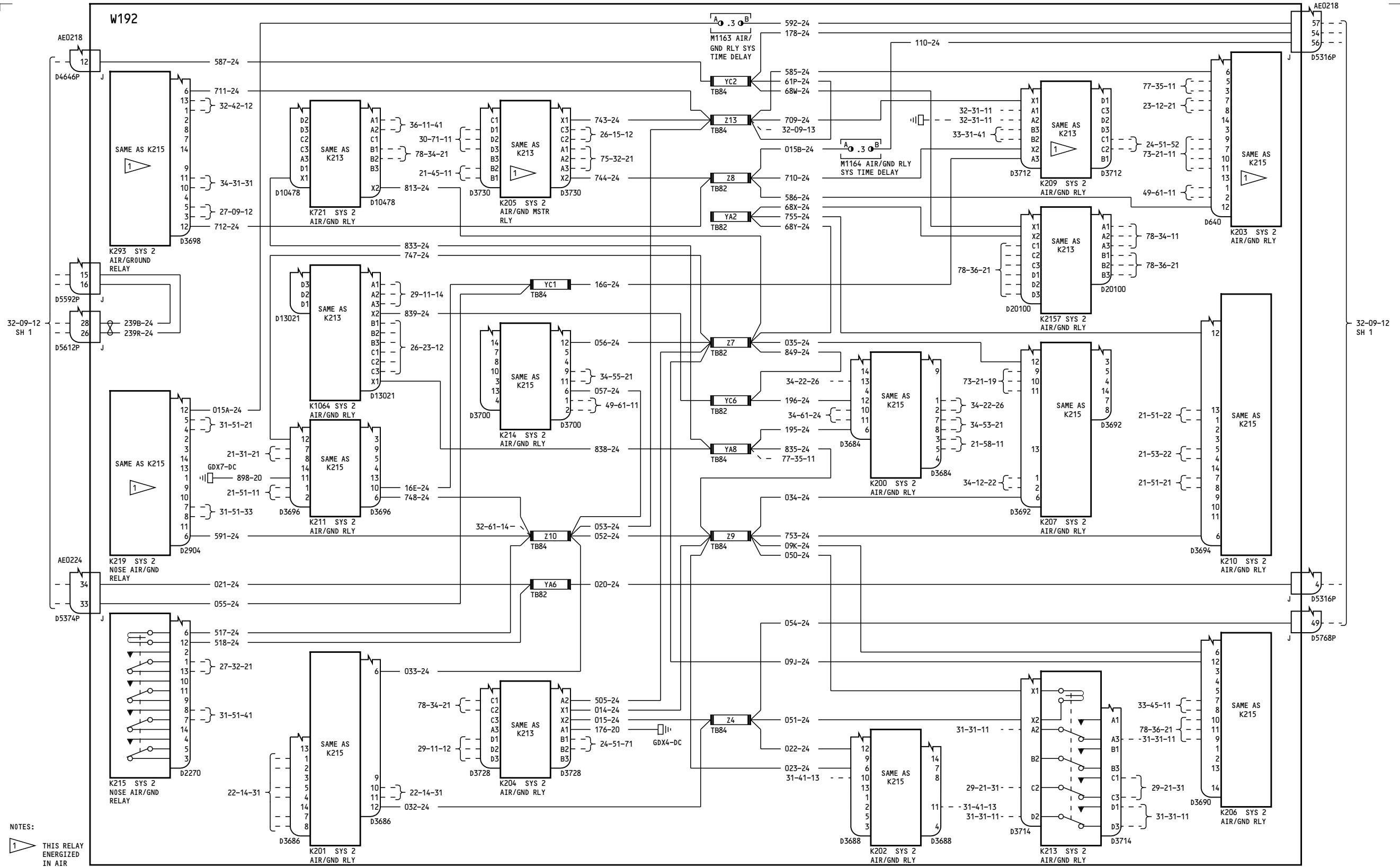

277-278

AIR/GROUND RELAYS-SYSTEM 2

32-09-12

Page 6.1  
Sheet 2  
Jan 21/2005

D280T132

Incorporates  
78-0062 R04

32-09-12

Page 6.1  
Sheet 2  
Jan 21/2005

195

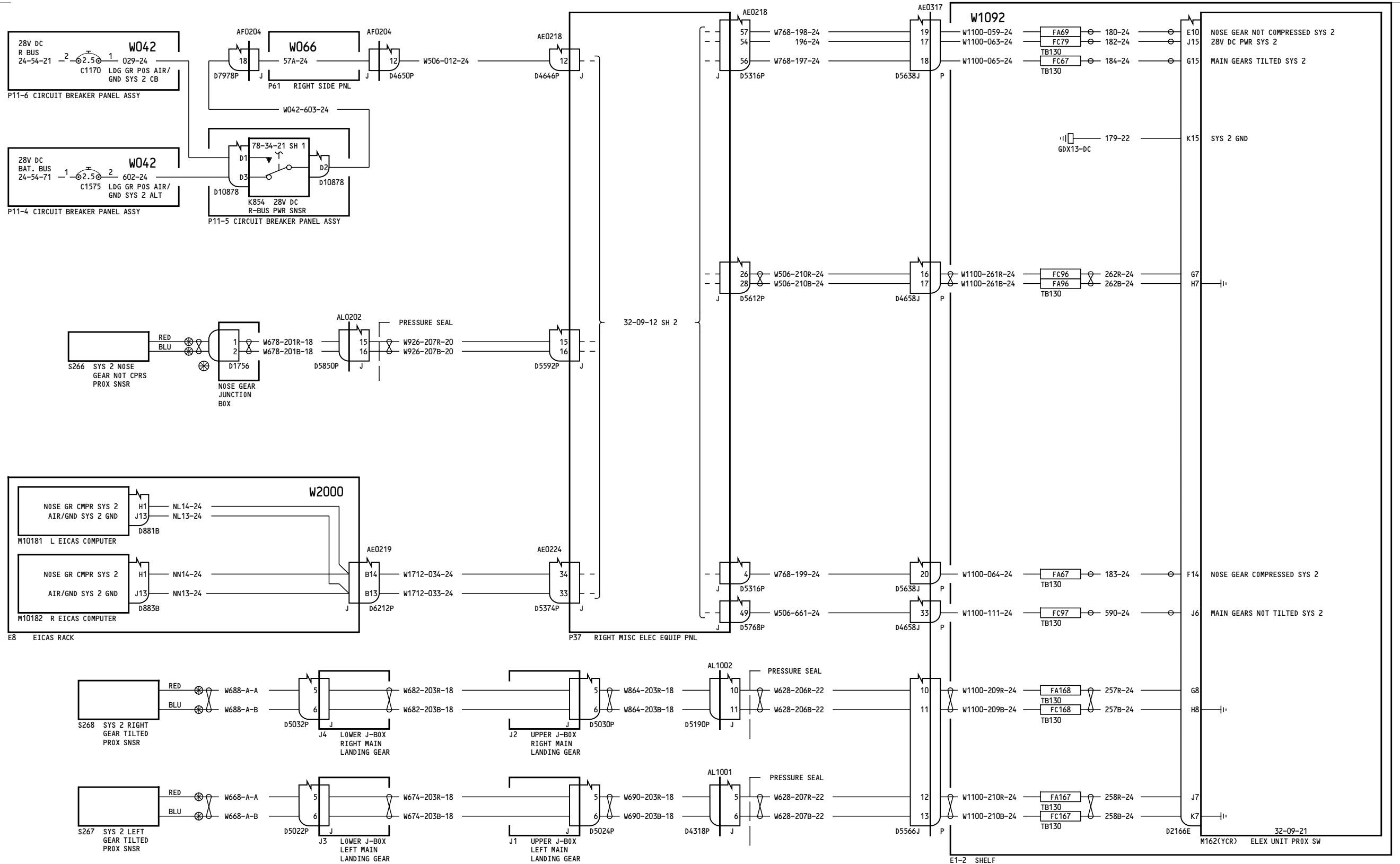

280

AIR/GROUND RELAYS-SYSTEM 2

D280T132

32-09-12

Page 7.1  
Sheet 1  
Jan 21/2005

32-09-12

Page 7.1  
Sheet 1  
Jan 21/2005

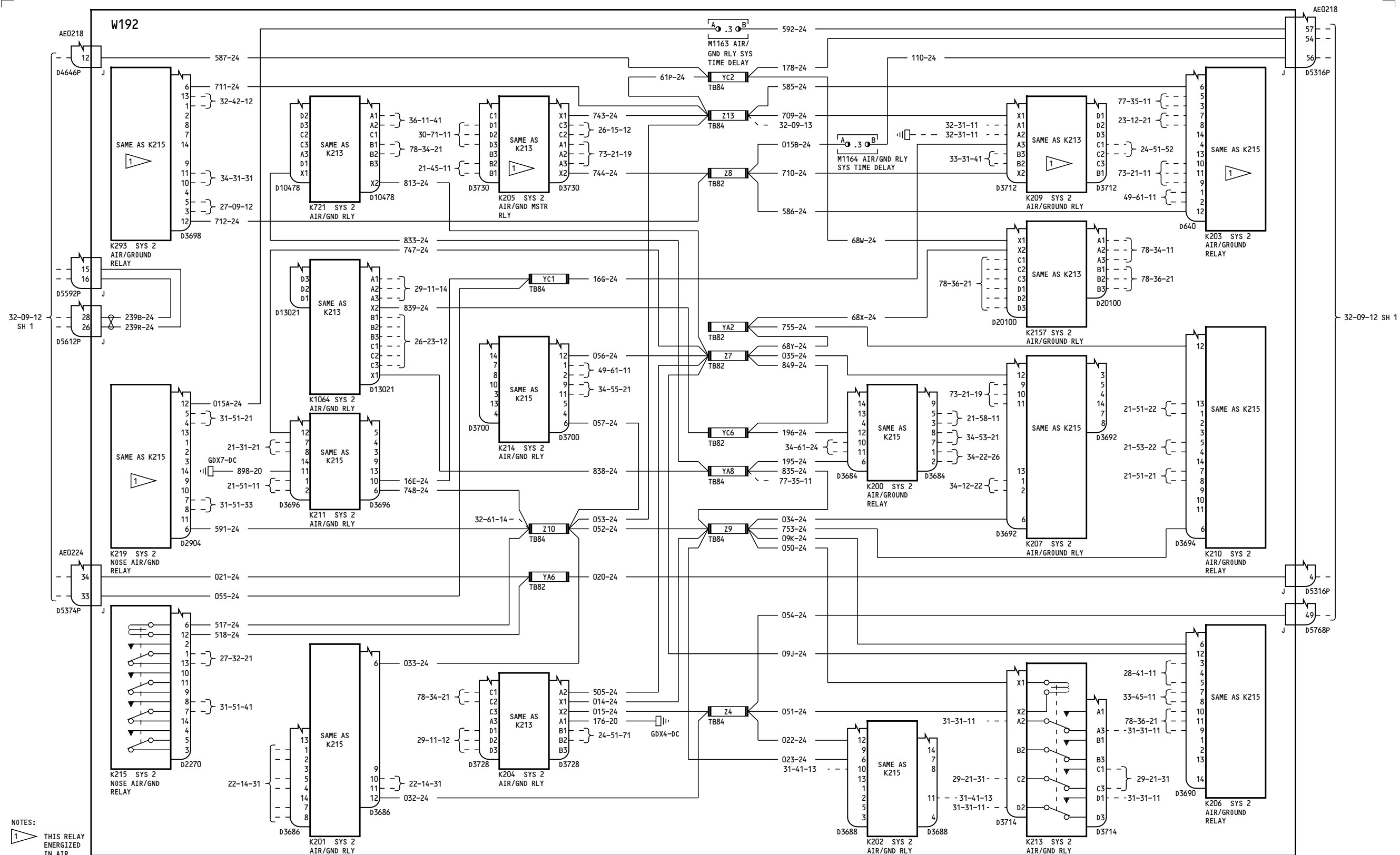

NOTES:  
1 THIS RELAY ENERGIZED IN AIR

P37 RIGHT MISC. ELEC. EQUIP. PNL

AIR/GROUND RELAYS-SYSTEM 2

D280T132

32-09-12

Page 7.1  
Sheet 2  
Jan 21/2005

Incorporates  
78-0062 R04

32-09-12

Page 7.1  
Sheet 2  
Jan 21/2005

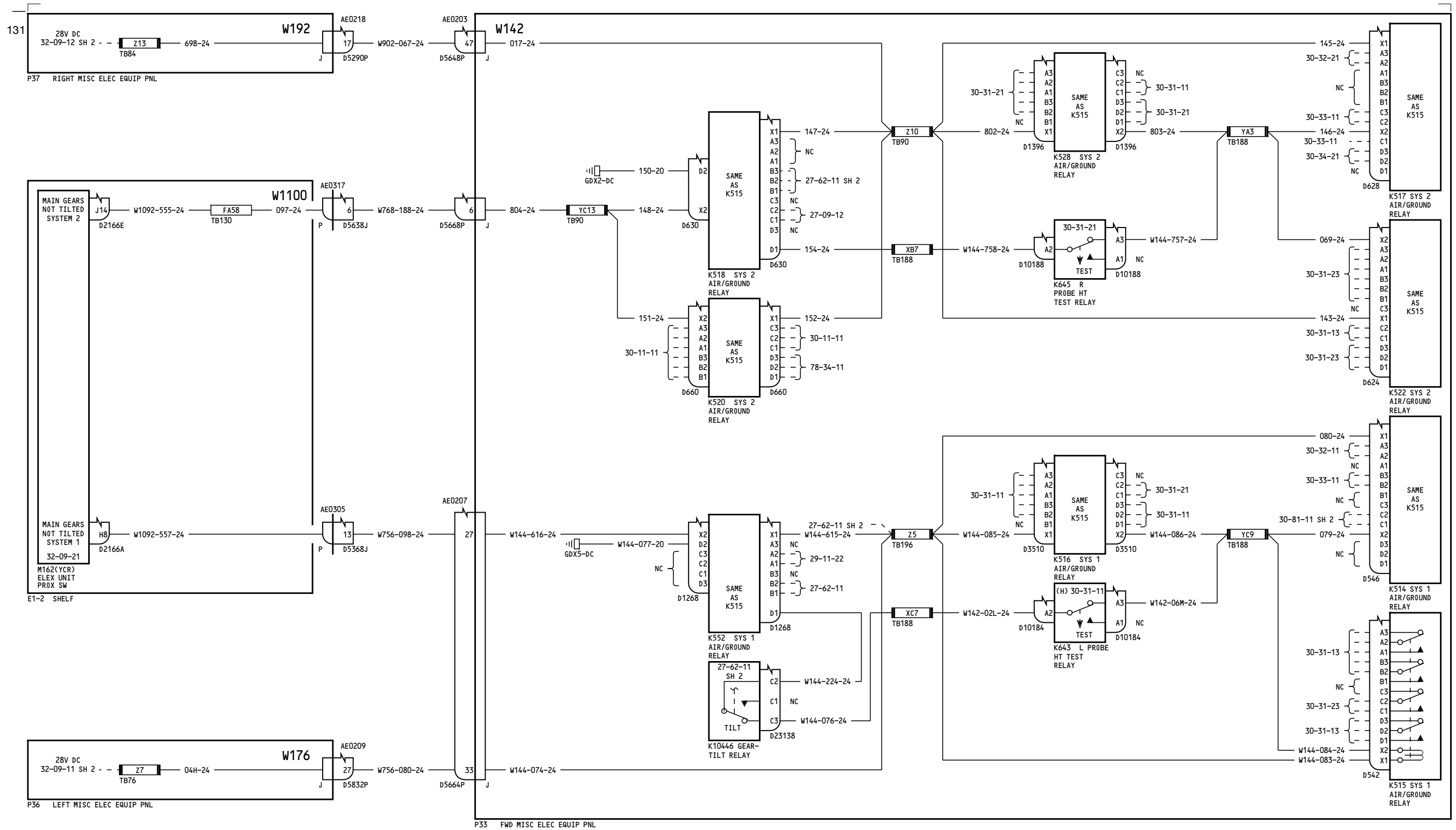

050, 150, 152-156, 162

**AIR/GROUND RELAYS-  
SYSTEM 1 & 2**

**32-09-13**

Page 1.1

Mar 09/2006

D280T132

- Incorporates
- ▶ 27A0160
  - ▶ 27A0160 R01
  - ▶ 78-0051FAA

**32-09-13**

Page 1.1

Mar 09/2006

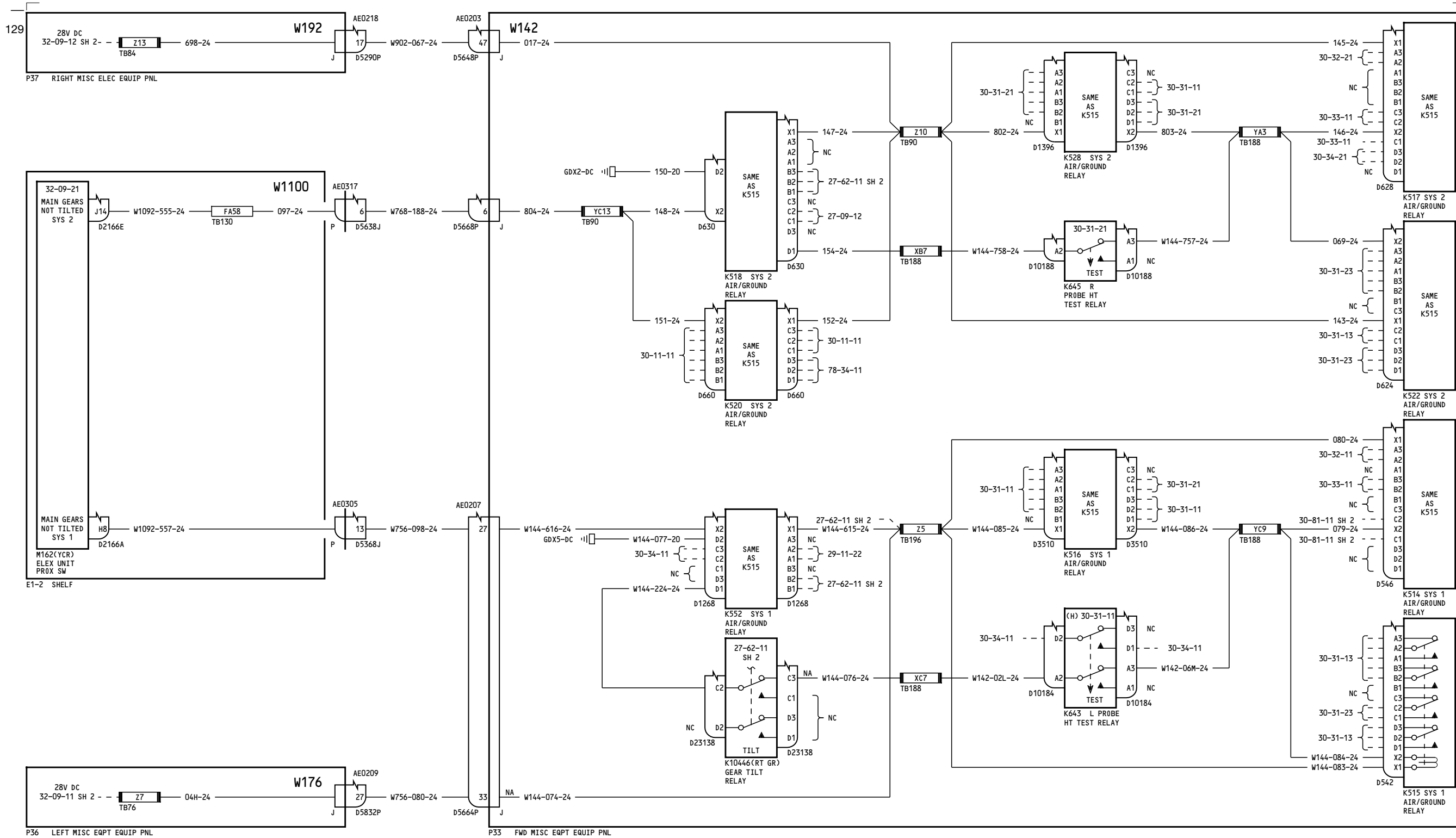

051, 151

**AIR/GROUND RELAYS-  
SYSTEM 1 & 2**

**32-09-13**

Page 2.1

Mar 09/2006

D280T132

Incorporates  
 ▹ 27A0160 R01  
 ▹ 78-0051FAA

**32-09-13**

Page 2.1

Mar 09/2006

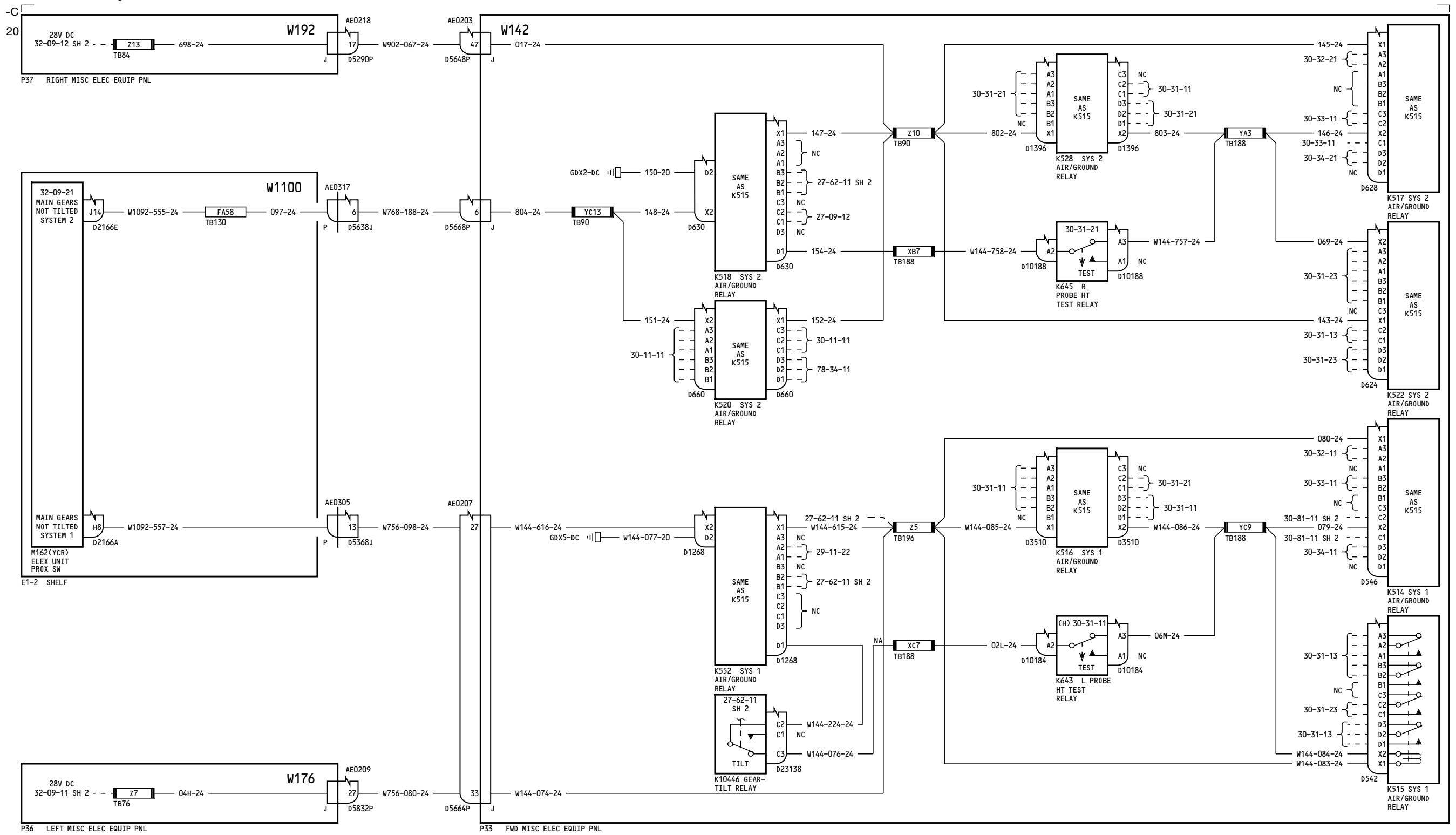

157

AIR/GROUND RELAYS - SYSTEM 1 & 2

32-09-13

Page 3.1

D280T132

Mar 09/2006

Incorporates 27A0160 27A0160 R01

32-09-13

Page 3.1

Mar 09/2006

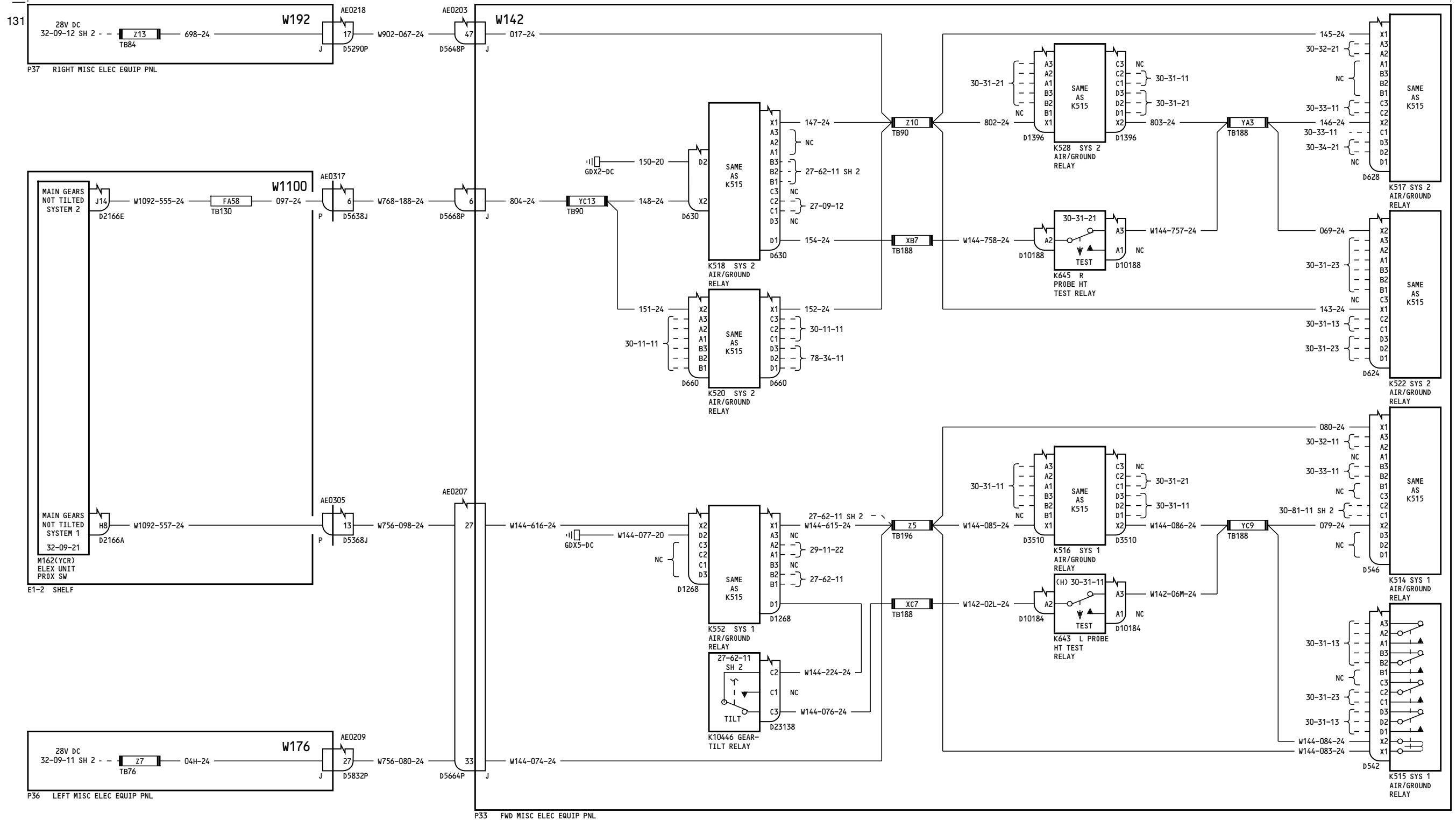

163-167

**AIR/GROUND RELAYS-  
SYSTEM 1 & 2**

**32-09-13**

Page 4.1

D280T132

Mar 09/2006

Incorporates  
 27A0160  
 27A0160 R01

**32-09-13**

Page 4.1

Mar 09/2006

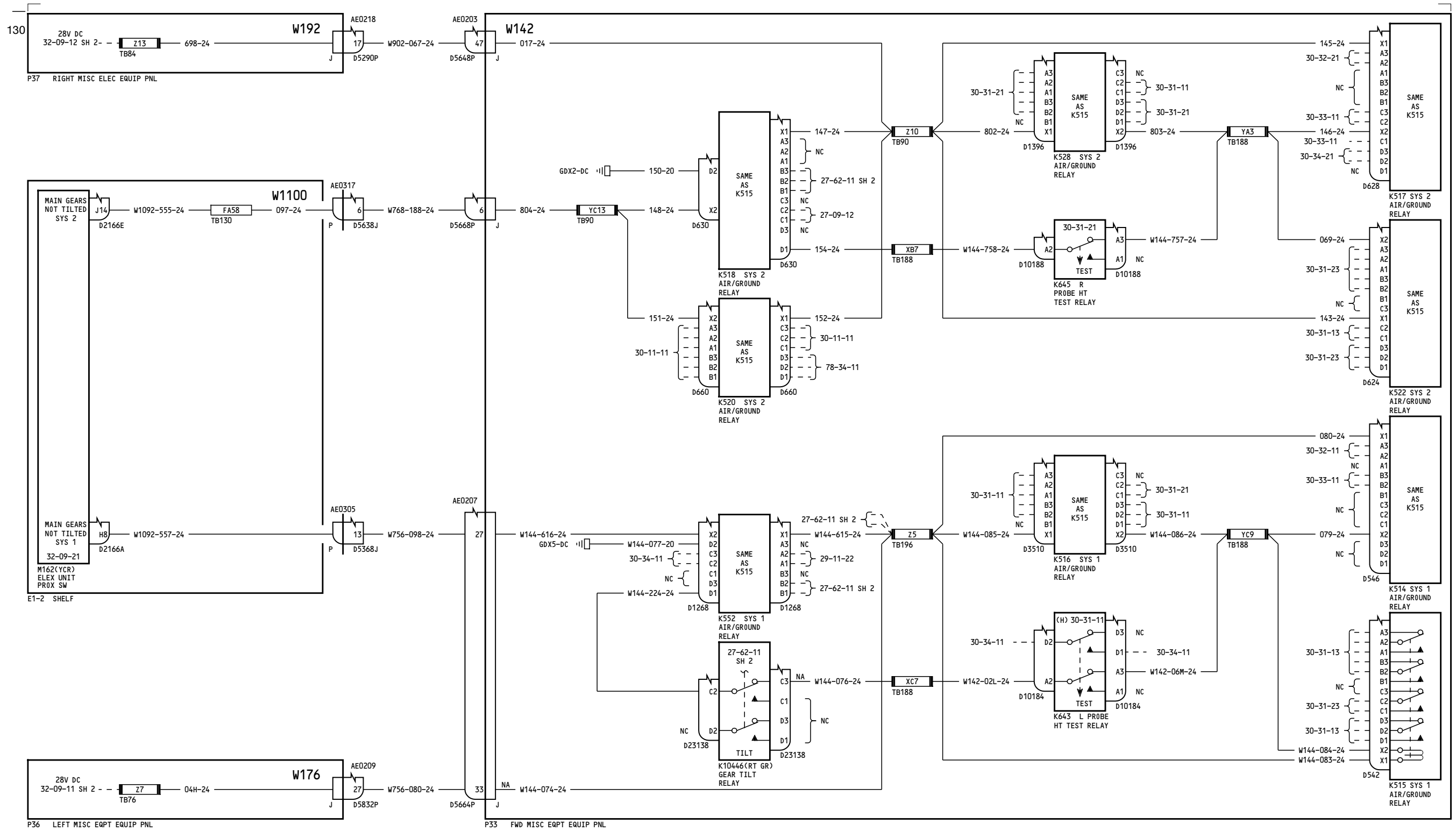

275-276

**AIR/GROUND RELAYS-  
SYSTEM 1 & 2**

**32-09-13**

Page 5.1

Mar 09/2006

D280T132

- Incorporates
- ▶ 27A0160
  - ▶ 27A0160 R01
  - ▶ 78-0051FAA

**32-09-13**

Page 5.1

Mar 09/2006



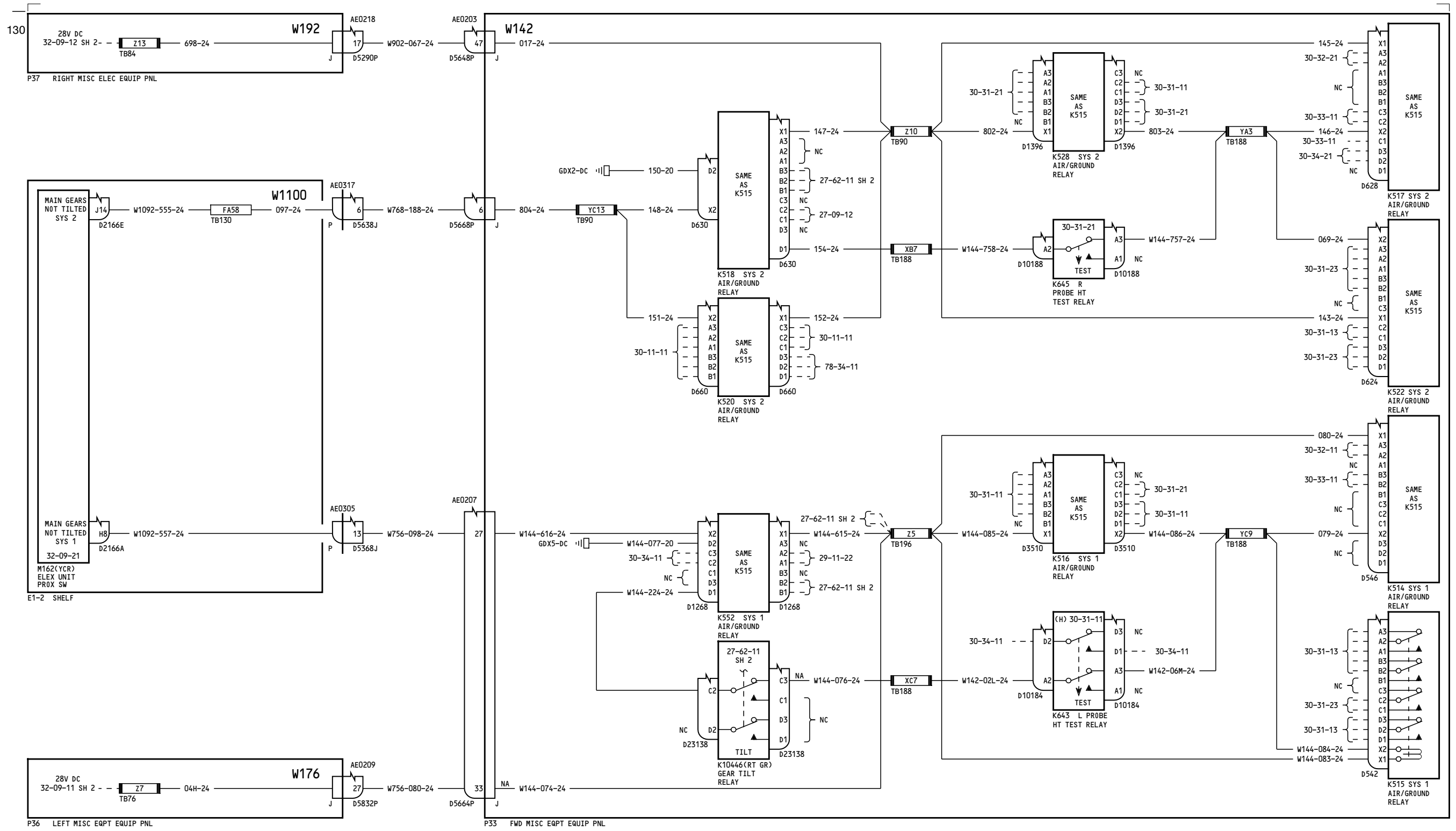

277-280

**AIR/GROUND RELAYS-  
SYSTEM 1 & 2**

**32-09-13**

Incorporates  
 27A0160  
 27A0160 R01

**32-09-13**

Page 6.1

Page 6.1

D280T132

Mar 09/2006

Mar 09/2006

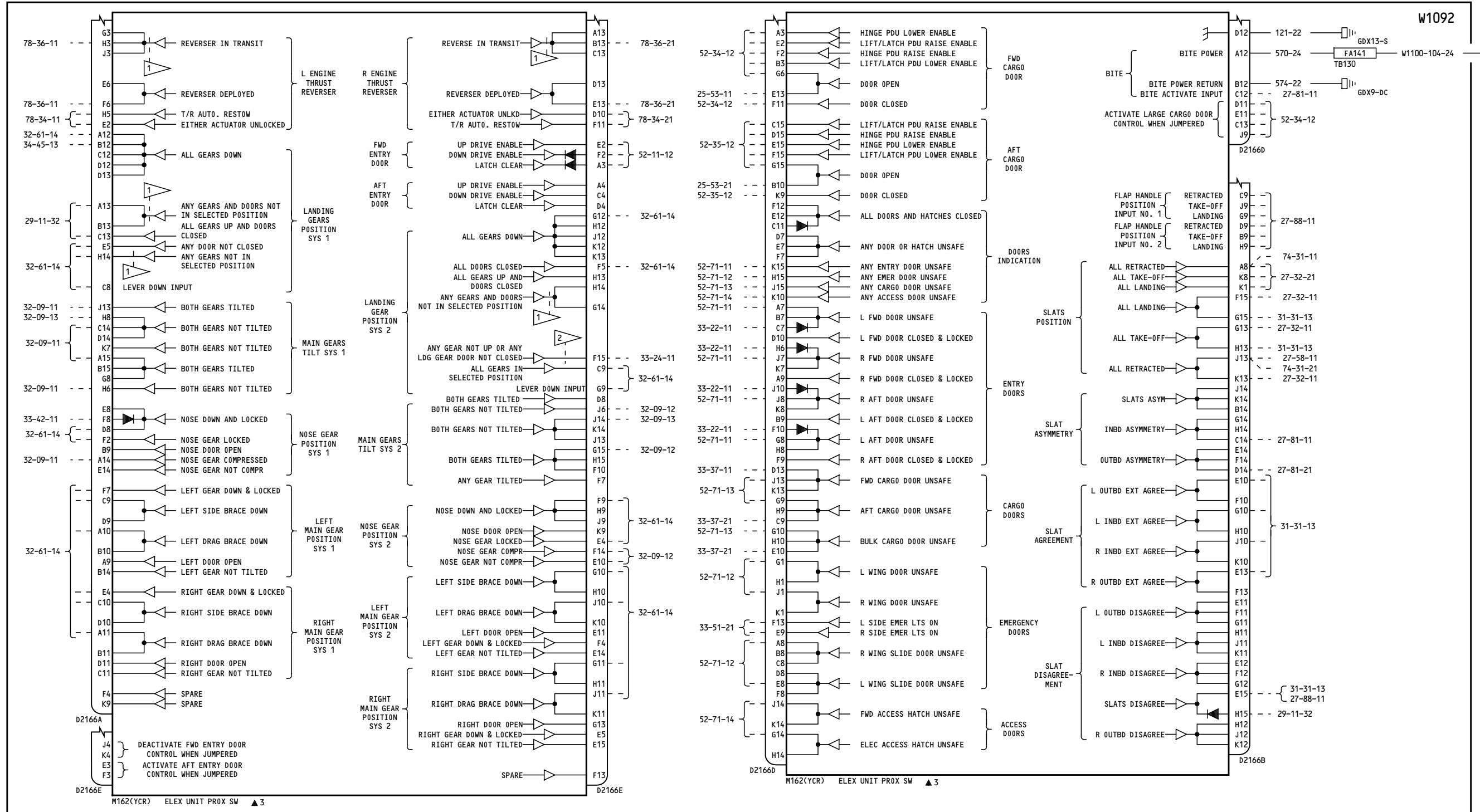

E1-2 SHELF  
 NOTES: 1 RELAY CONTACT, FAILS CONDUCTING 2 RELAY CONTACT, FAILS NON-CONDUCTING

050-099

**PROXIMITY SWITCH ELECTRONICS UNIT OUTPUT INTERFACE**

32-09-21

Page 1

D280T132

Jan 21/2005

32-09-21

Page 1

Jan 21/2005

BOEING PROPRIETARY - Copyright © - Unpublished Work - See title page for details.

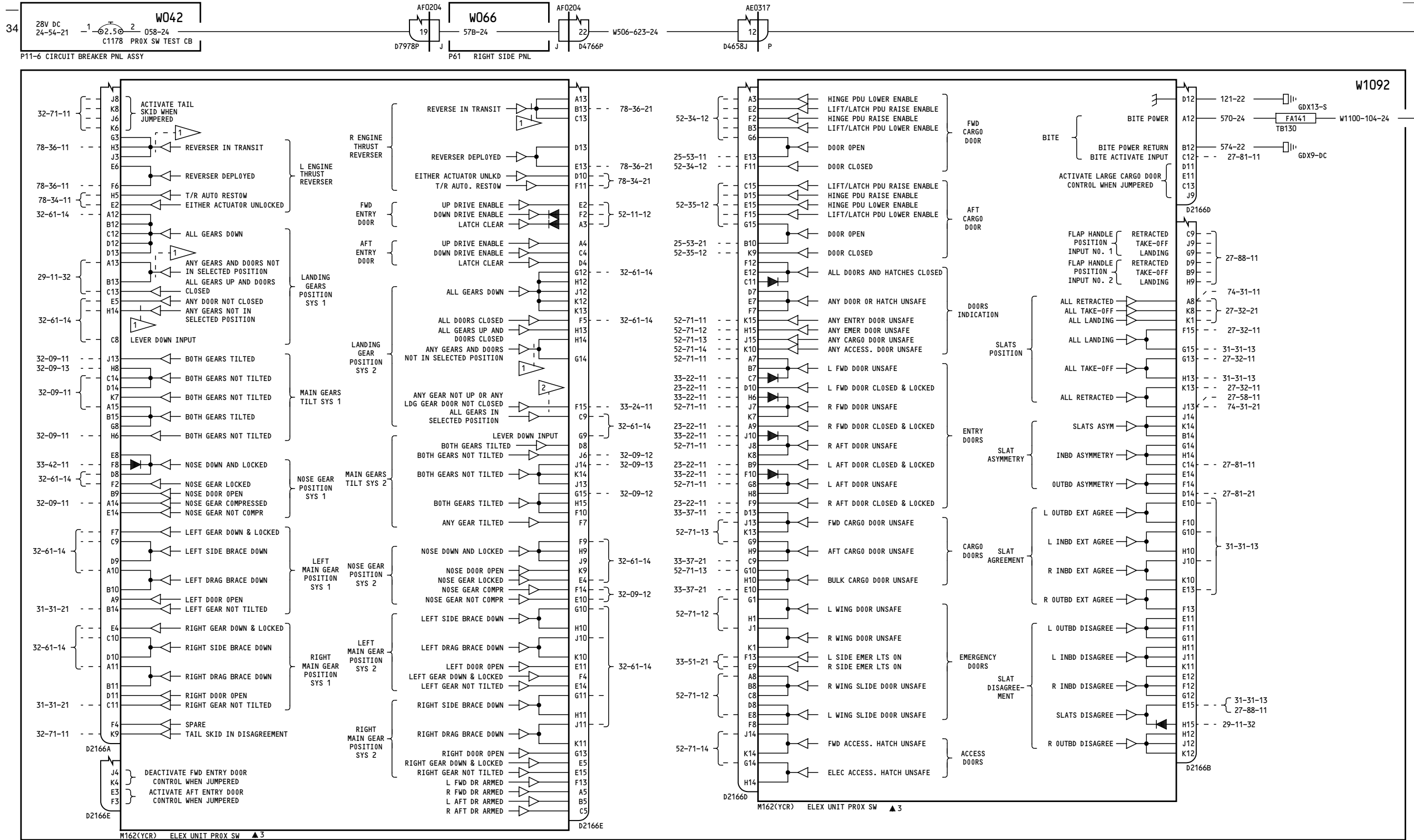

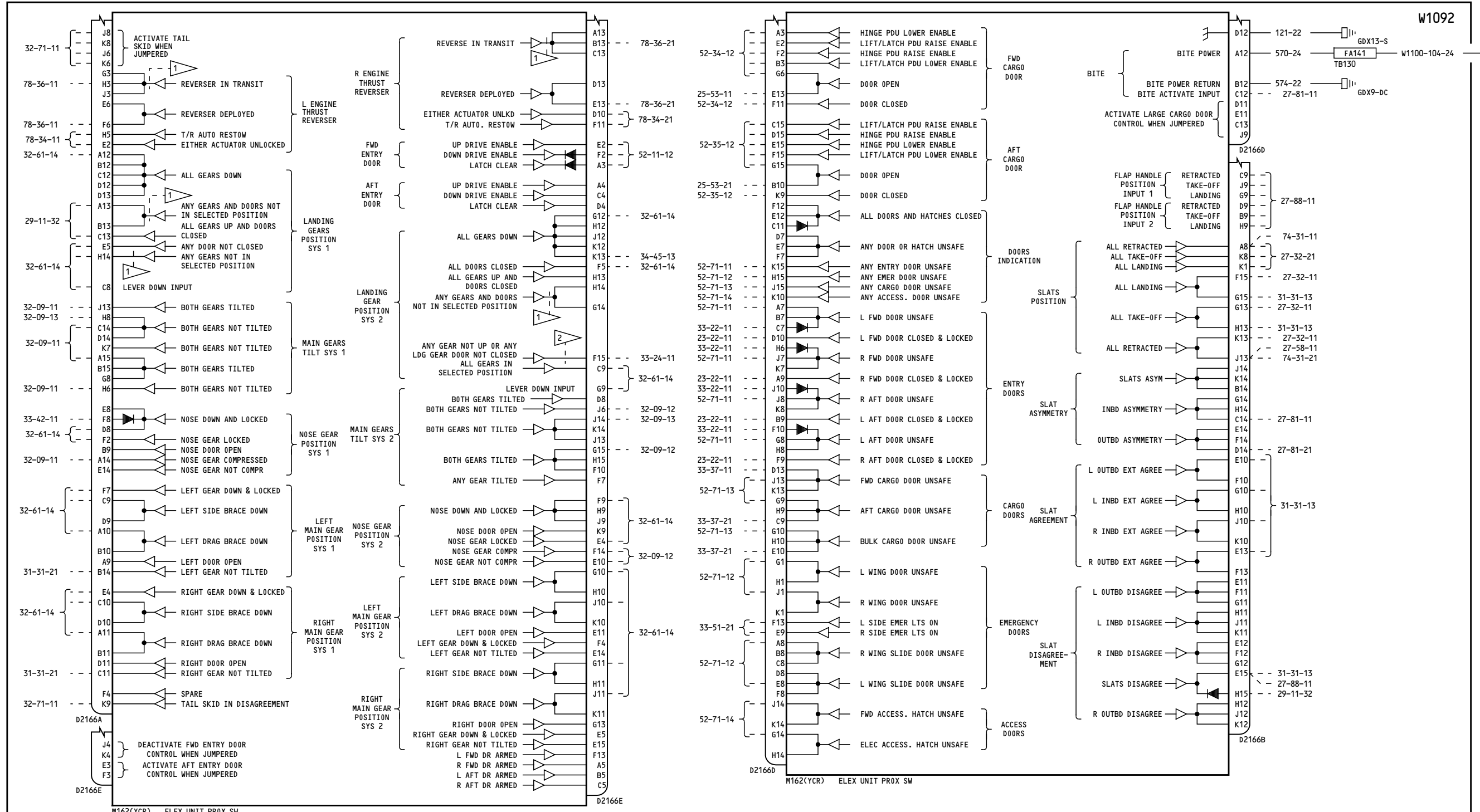
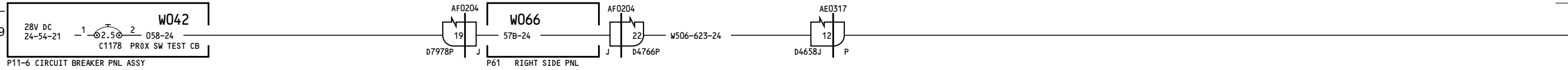

NOTES: 1 RELAY CONTACT, FAILS CONDUCTING 2 RELAY CONTACT, FAILS NON-CONDUCTING

153-154

**PROXIMITY SWITCH ELECTRONICS UNIT OUTPUT INTERFACE**

D280T132

**32-09-21**

Page 2.1  
Jan 21/2005

Incorporates 34-0133

**32-09-21**

Page 2.1  
Jan 21/2005

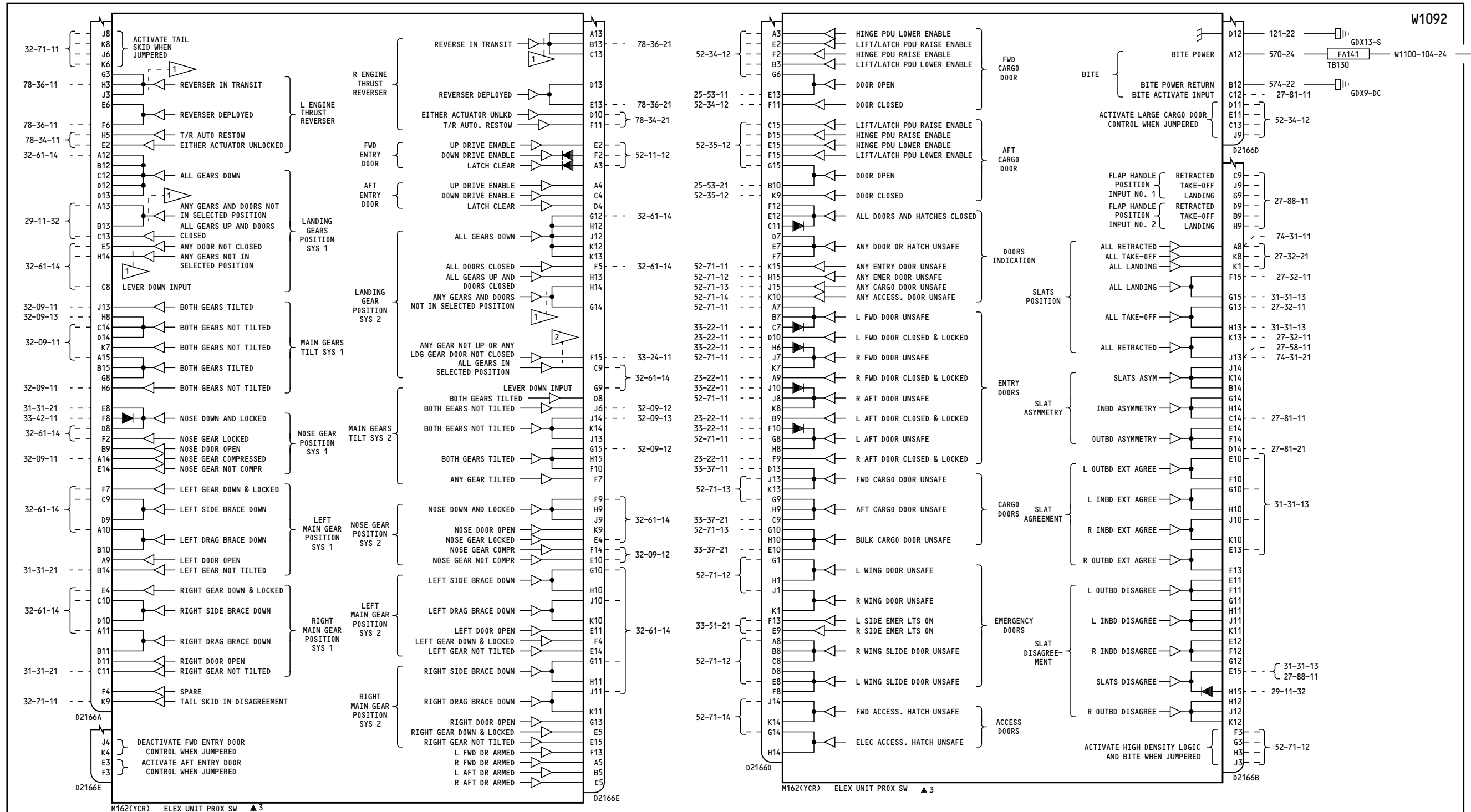
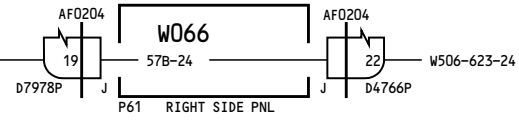
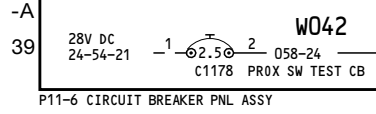

NOTES: RELAY CONTACT, FAILS CONDUCTING RELAY CONTACT, FAILS NON-CONDUCTING

275-299

**PROXIMITY SWITCH  
ELECTRONICS UNIT  
OUTPUT INTERFACE**

**32-09-21**

Page 3

D280T132

Jan 21/2005

**32-09-21**

Page 3

Jan 21/2005

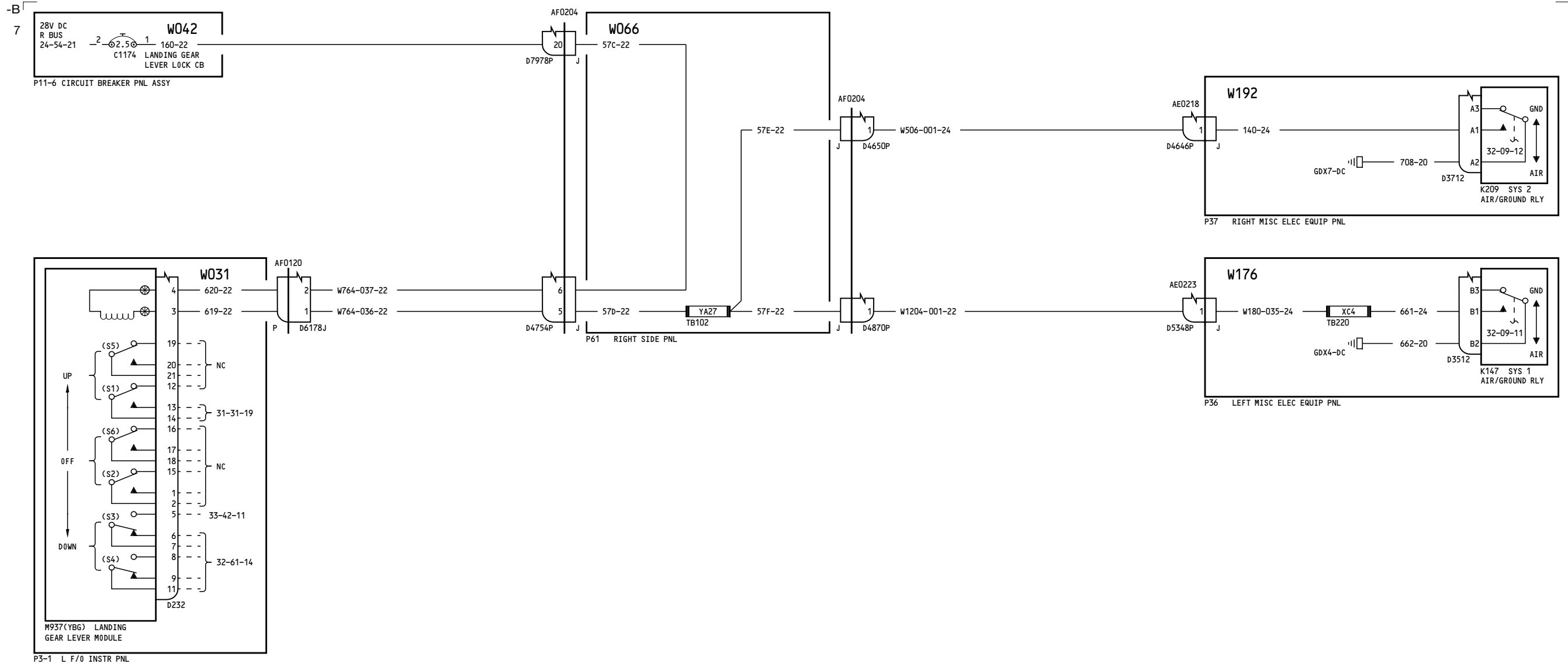

ALL	<b>LANDING GEAR LEVER LOCK</b>
	D280T132

**32-31-11**  
Page 1  
Jan 21/2005

**32-31-11**  
Page 1  
Jan 21/2005

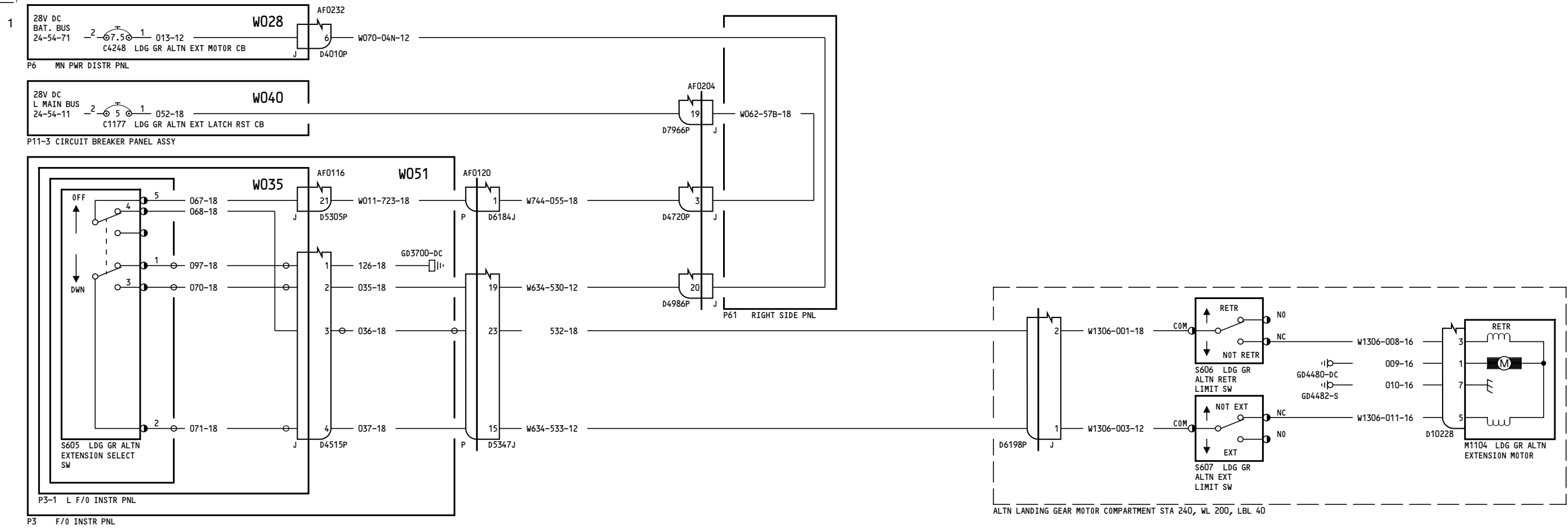

ALL	<p align="center"><b>LANDING GEAR ALTERNATE EXTENSION SYSTEM</b></p> <p align="center">D280T132</p>
-----	---

**32-35-11**

Page 1

Jan 21/2005

**32-35-11**

Page 1

Jan 21/2005

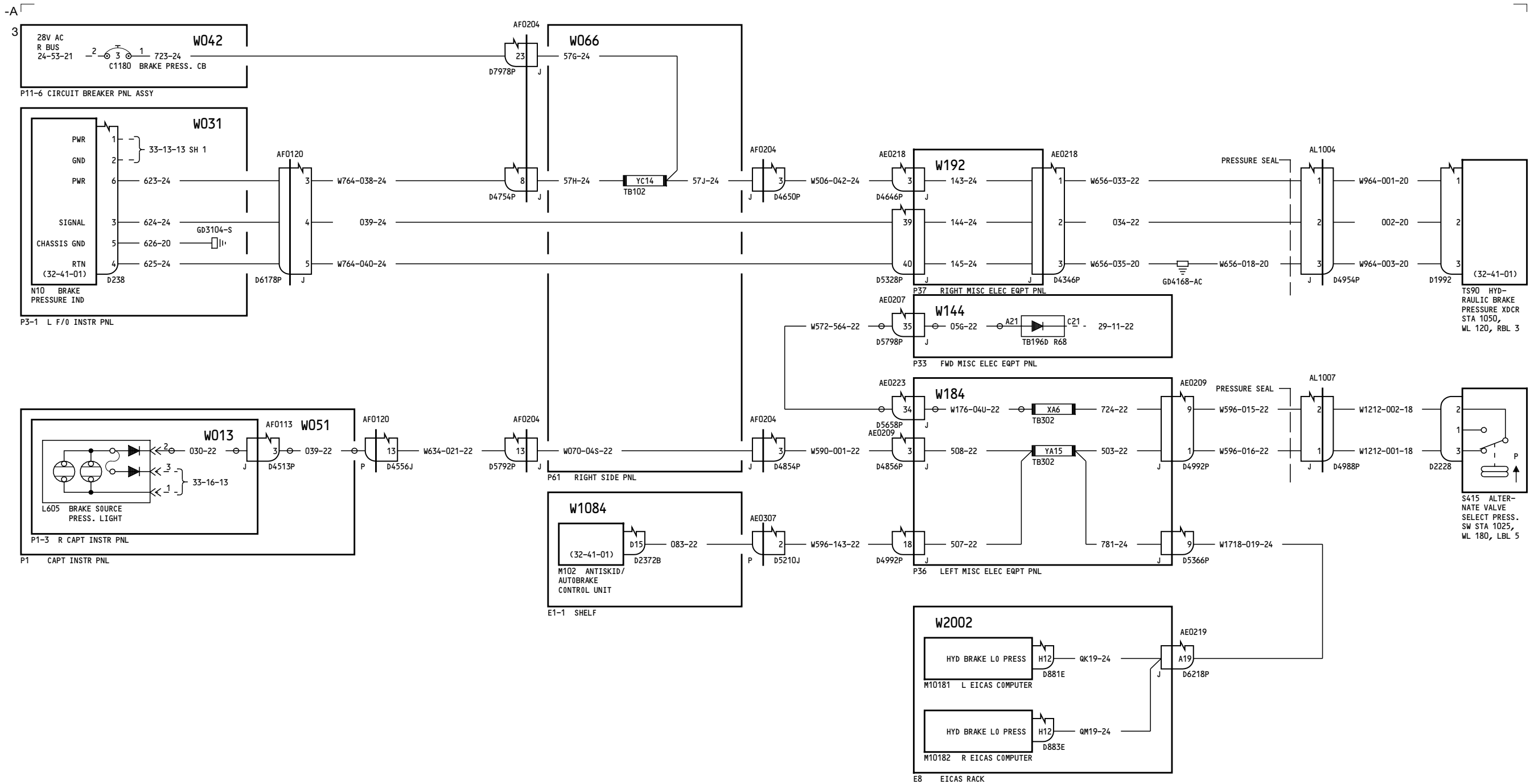

050-099

**BRAKE PRESSURE INDICATION**

**32-41-11**

Page 1

D280T132

Jan 21/2005

**32-41-11**

Page 1

Jan 21/2005



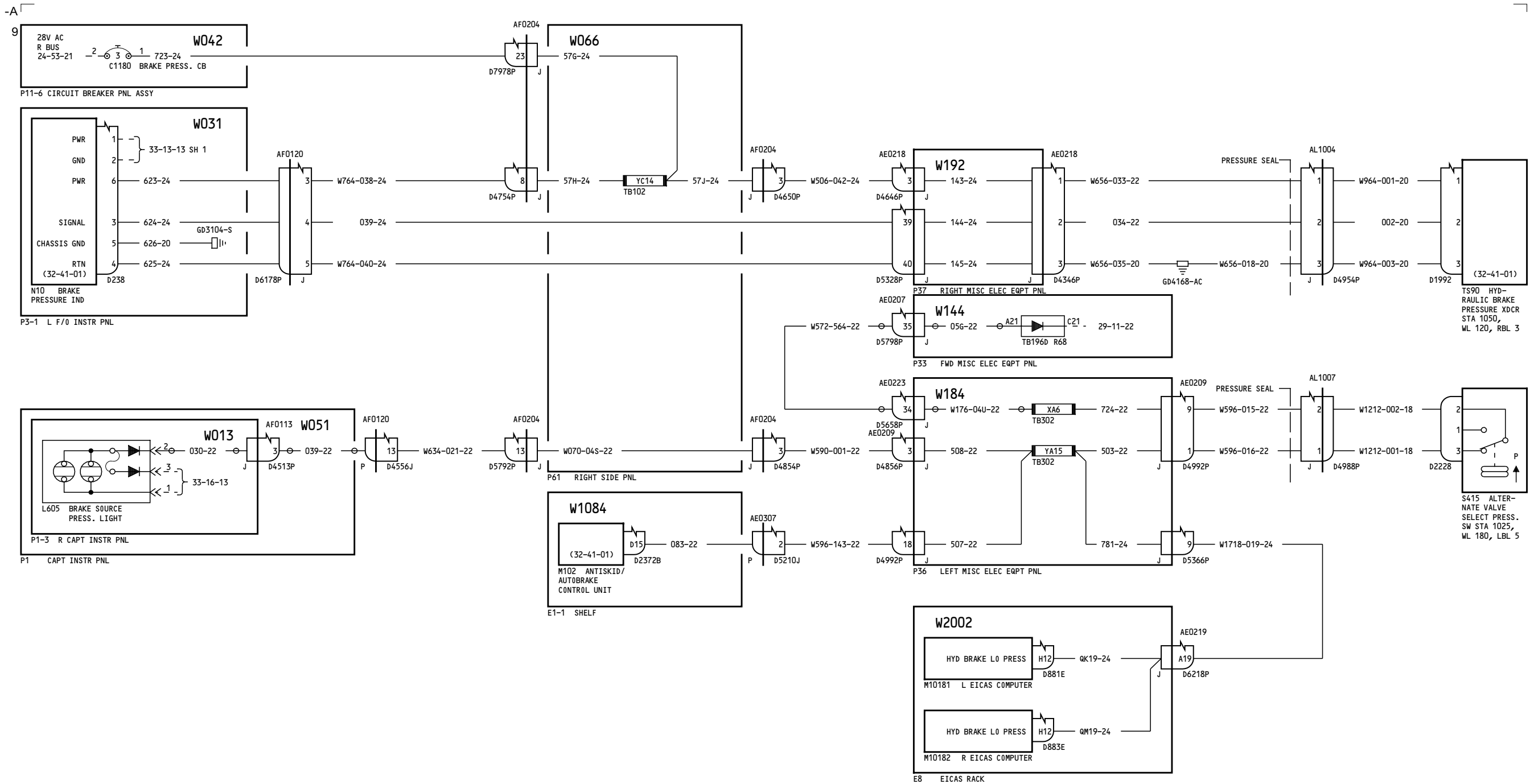

37

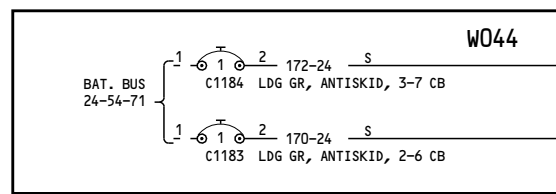

P11-4 CIRCUIT BREAKER PNL ASSY

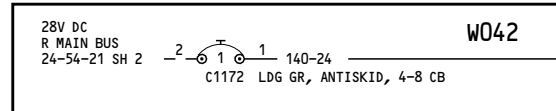

P11-6 CIRCUIT BREAKER PNL ASSY

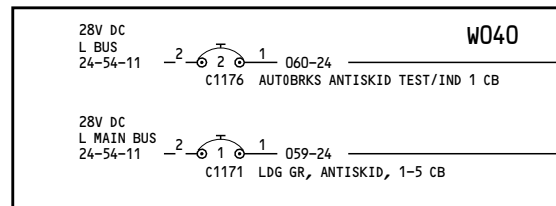

P11-3 CIRCUIT BREAKER PNL ASSY

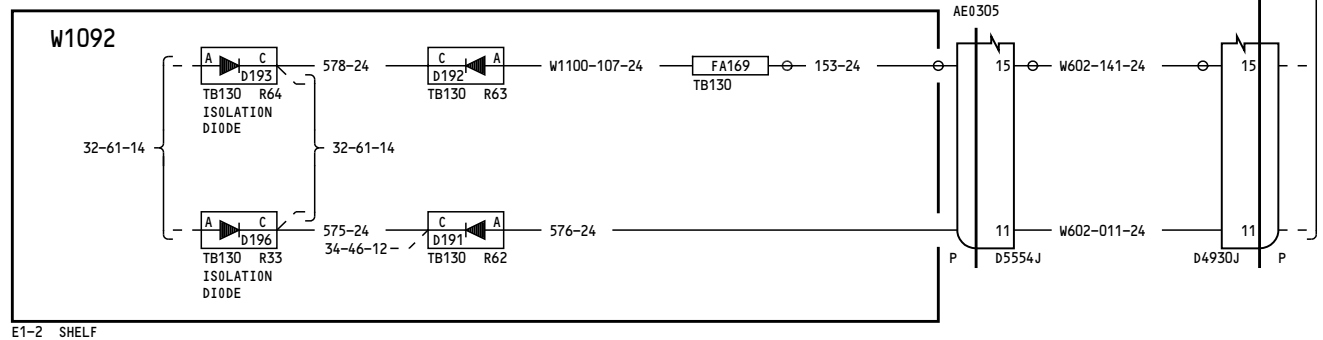
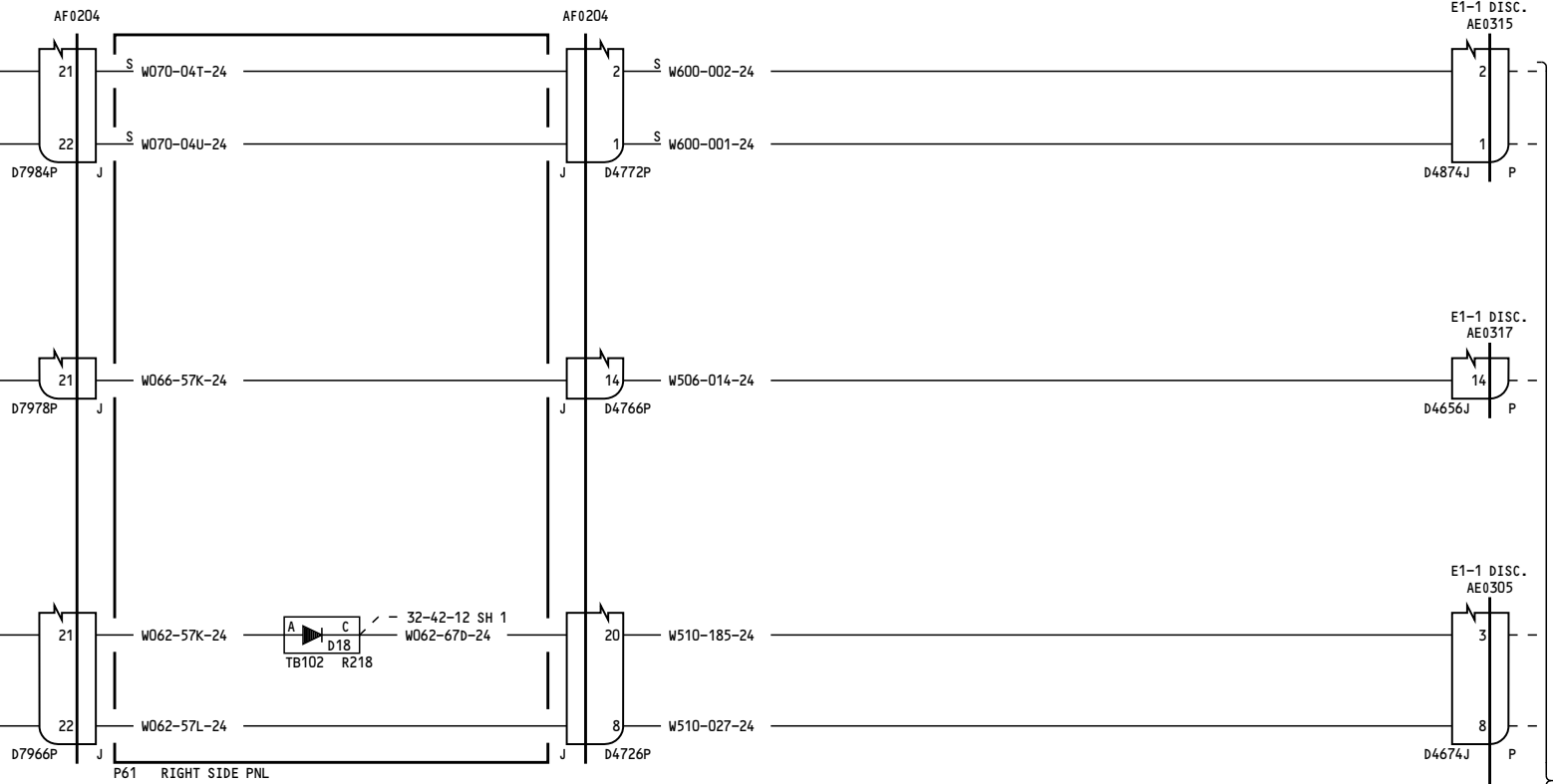

E1-2 SHELF

050-099

ANTISKID SYSTEM

D280T132

32-42-11

Page 1  
Sheet 1  
Jan 21/2005

32-42-11

Page 1  
Sheet 1  
Jan 21/2005

-A  
37

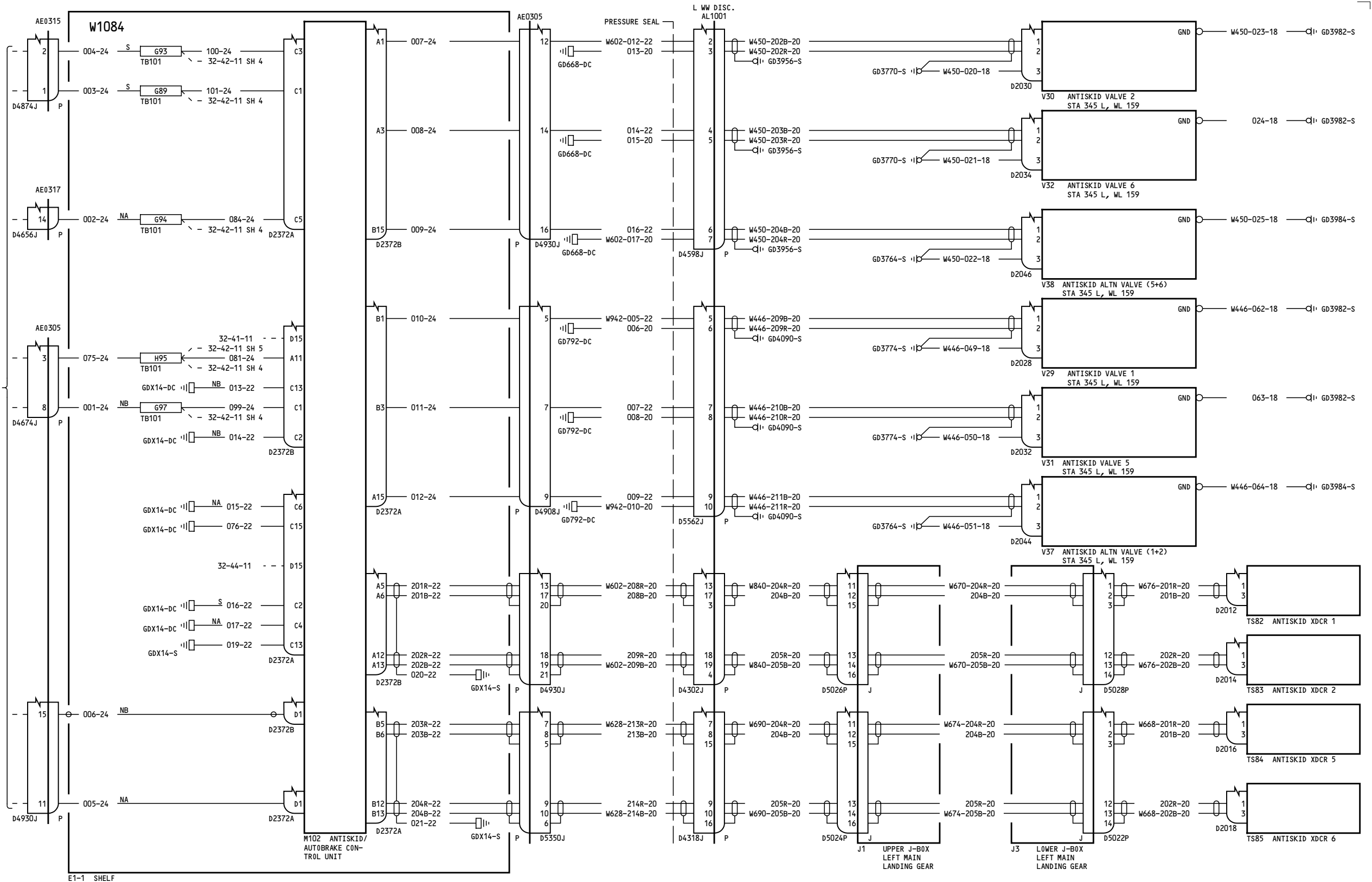

050-099

ANTISKID SYSTEM

32-42-11

Page 1  
Sheet 2  
Jan 21/2005

D280T132

32-42-11

Page 1  
Sheet 2  
Jan 21/2005

37

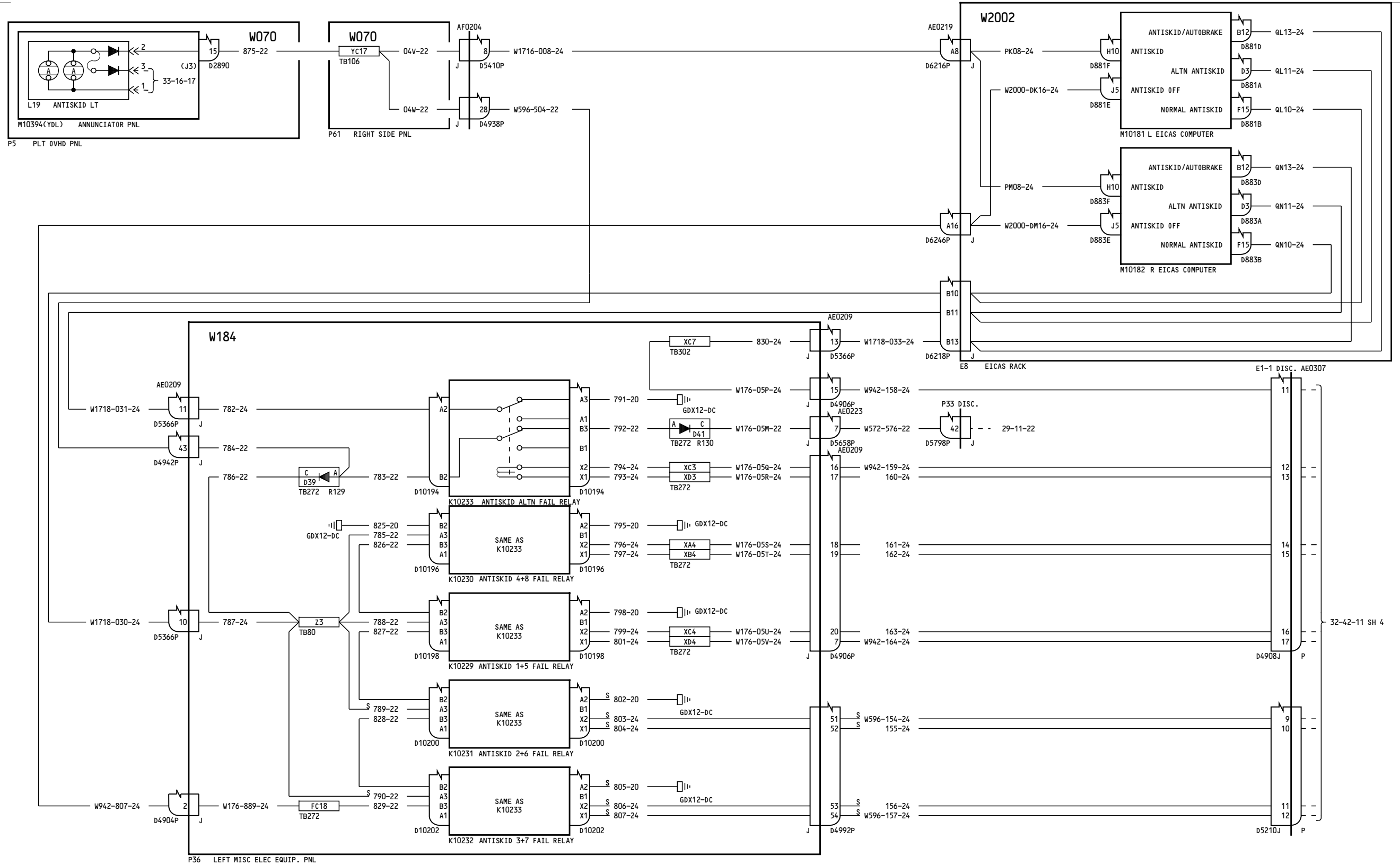

050-099

ANTISKID SYSTEM

32-42-11

Page 1  
Sheet 3  
Jan 21/2005

D280T132

32-42-11

Page 1  
Sheet 3  
Jan 21/2005

-A  
37

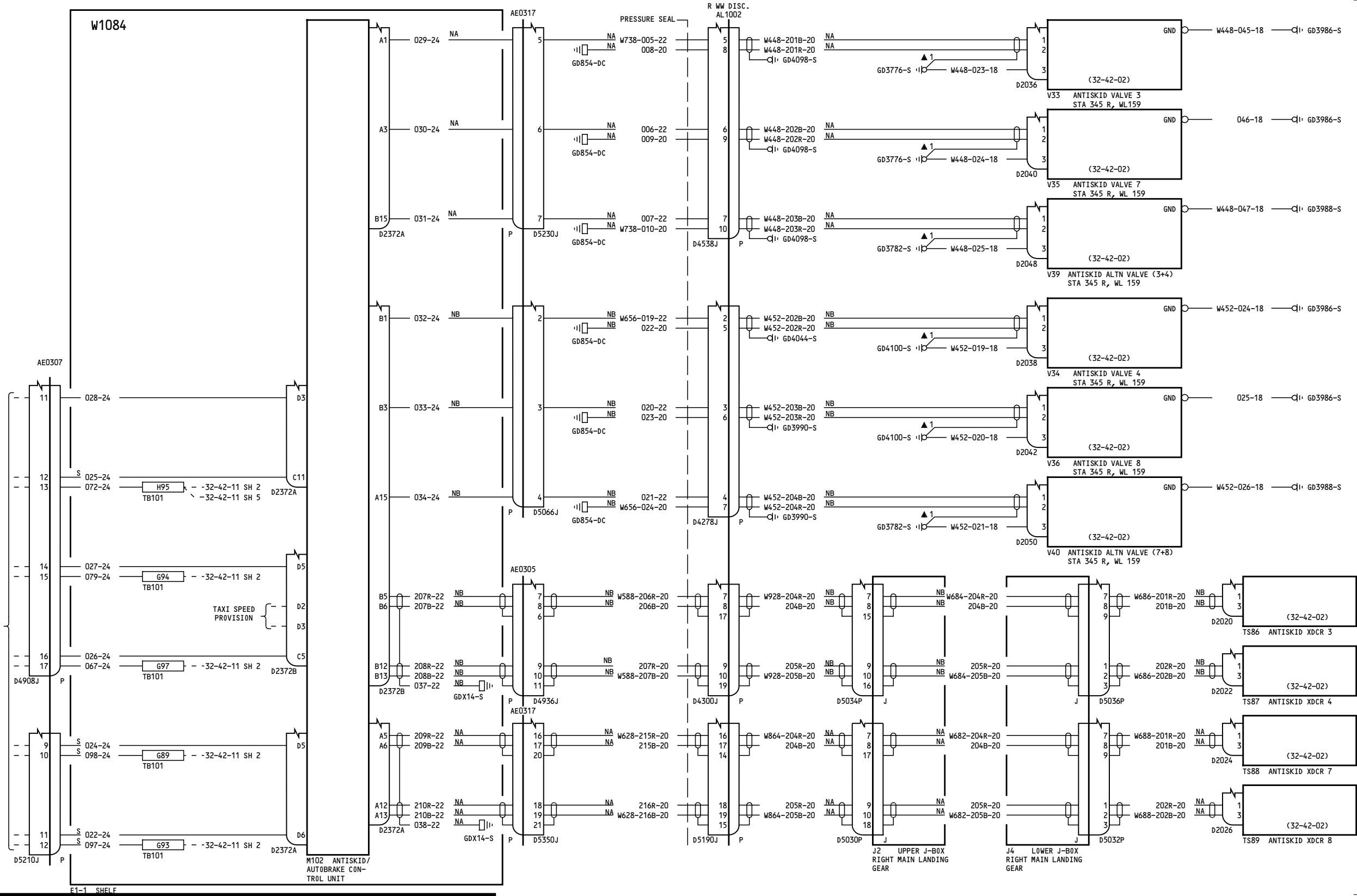

050-099

**ANTISKID SYSTEM**

**32-42-11**

D280T132

**32-42-11**

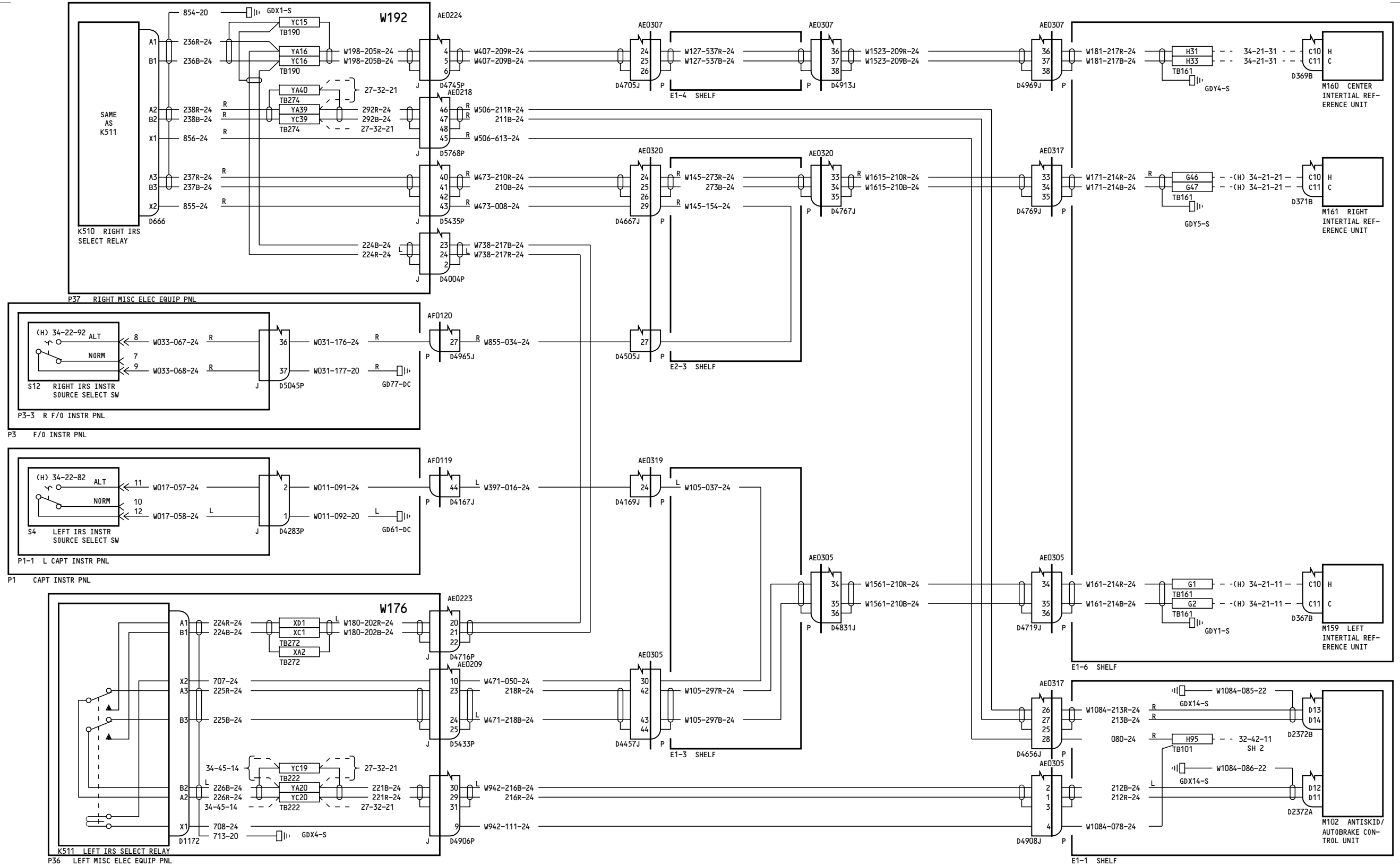

108

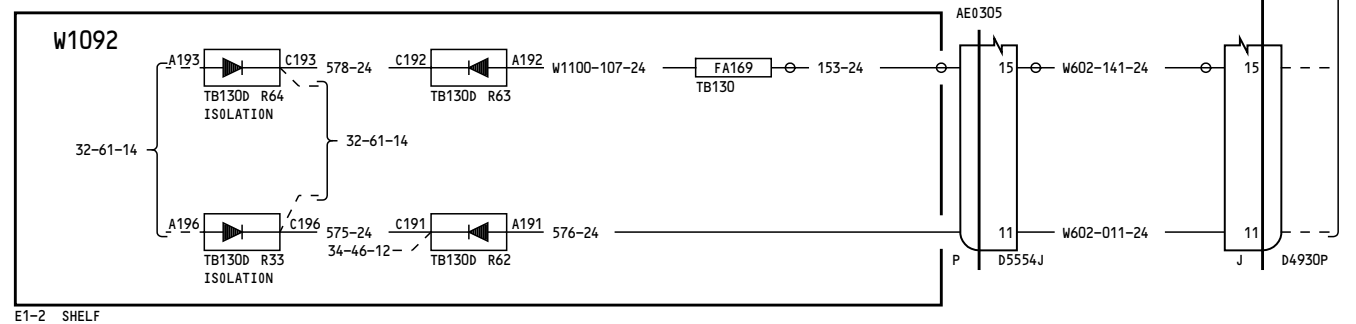
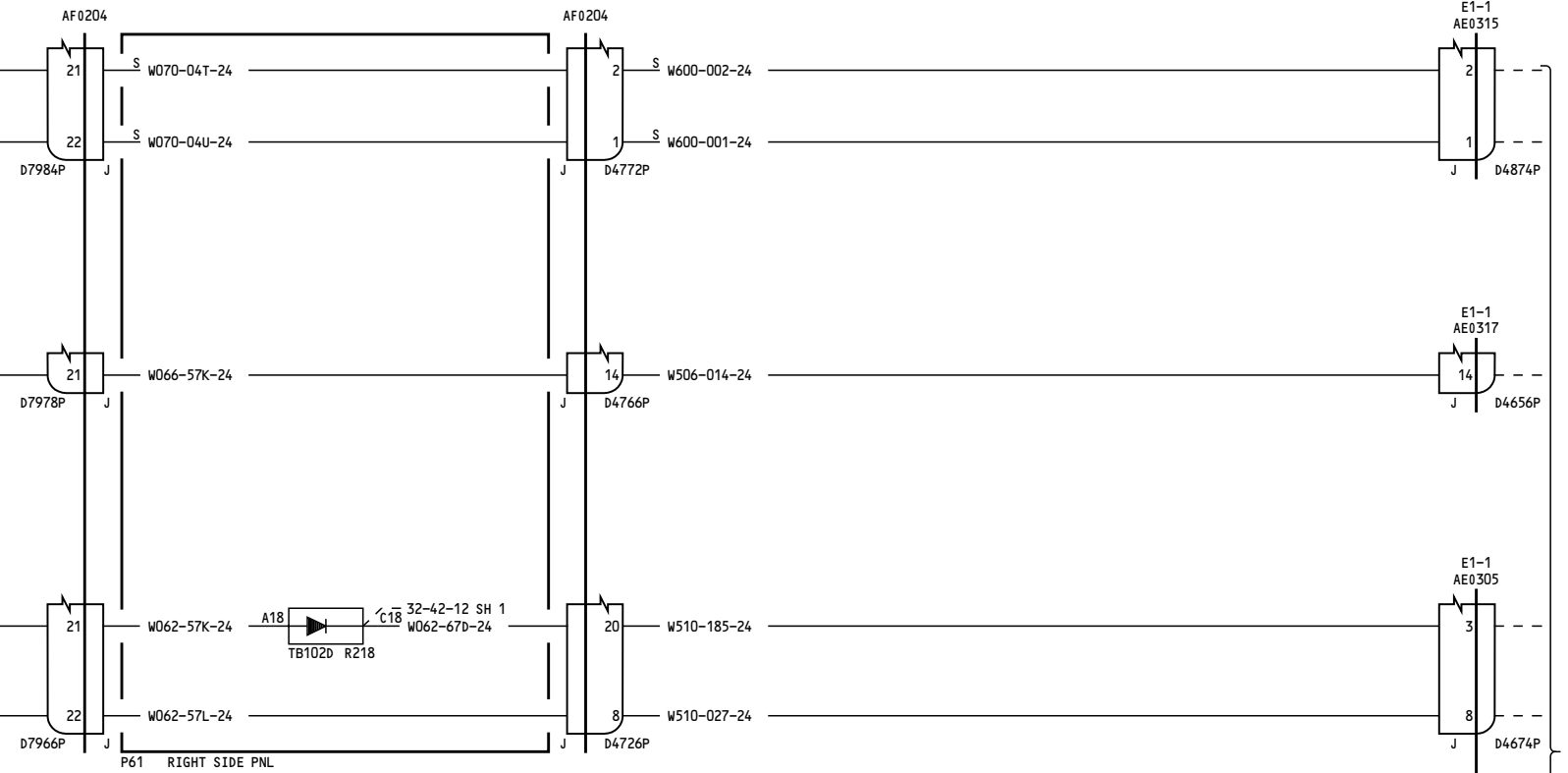
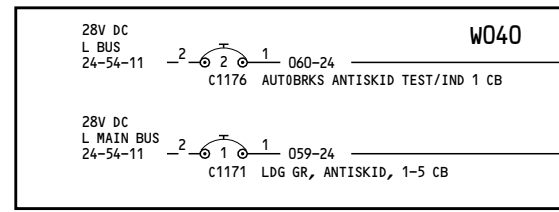
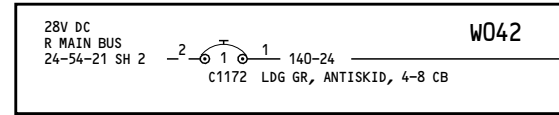
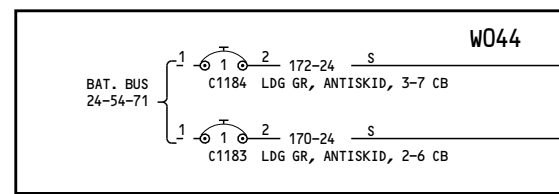

150-152

ANTISKID SYSTEM

D280T132

32-42-11

Page 2.1  
Sheet 1  
Jan 21/2005

32-42-11

Page 2.1  
Sheet 1  
Jan 21/2005

-A  
97

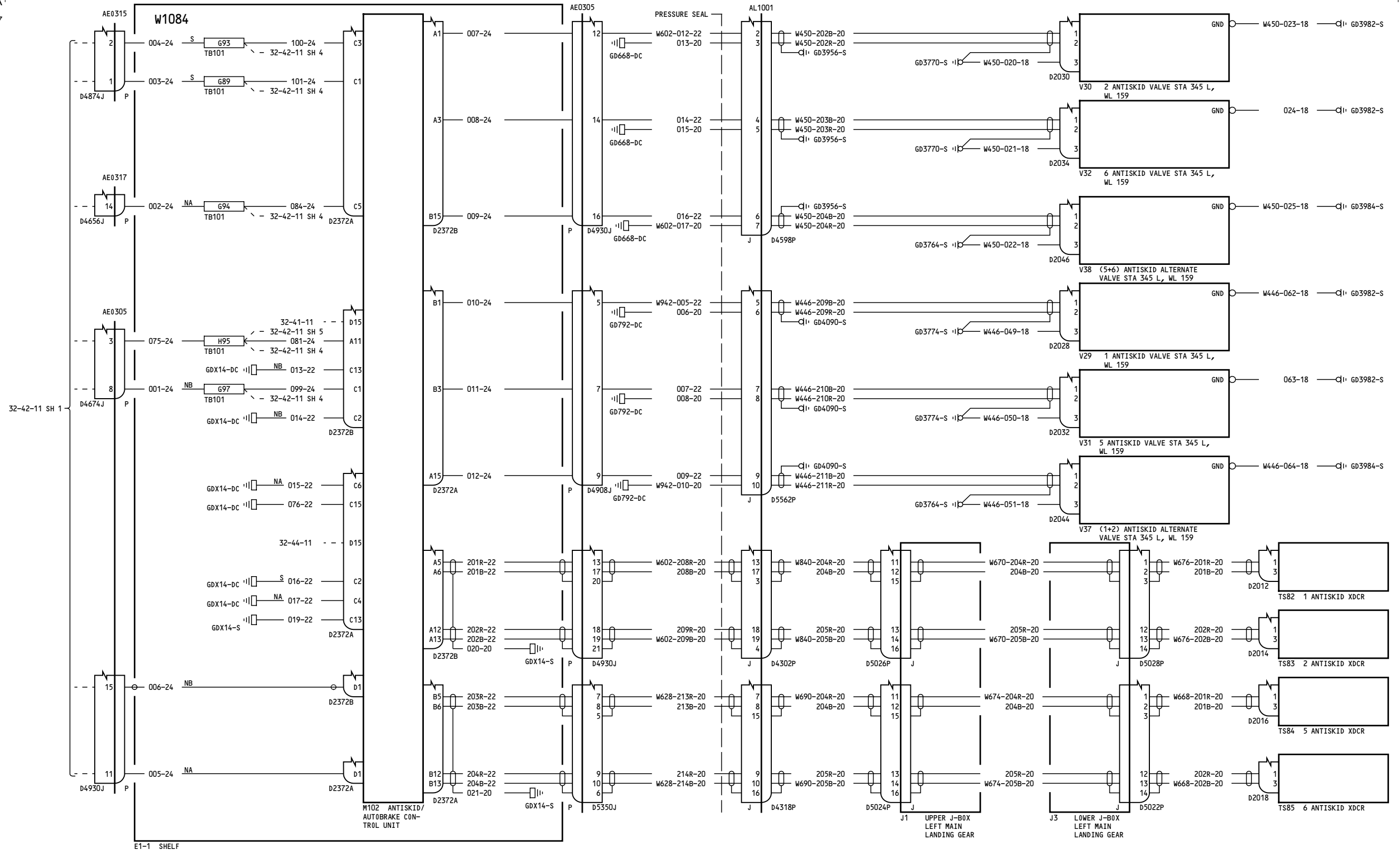

150-152

ANTISKID SYSTEM

32-42-11

Page 2.1  
Sheet 2  
Jan 21/2005

D280T132

32-42-11

Page 2.1  
Sheet 2  
Jan 21/2005



101

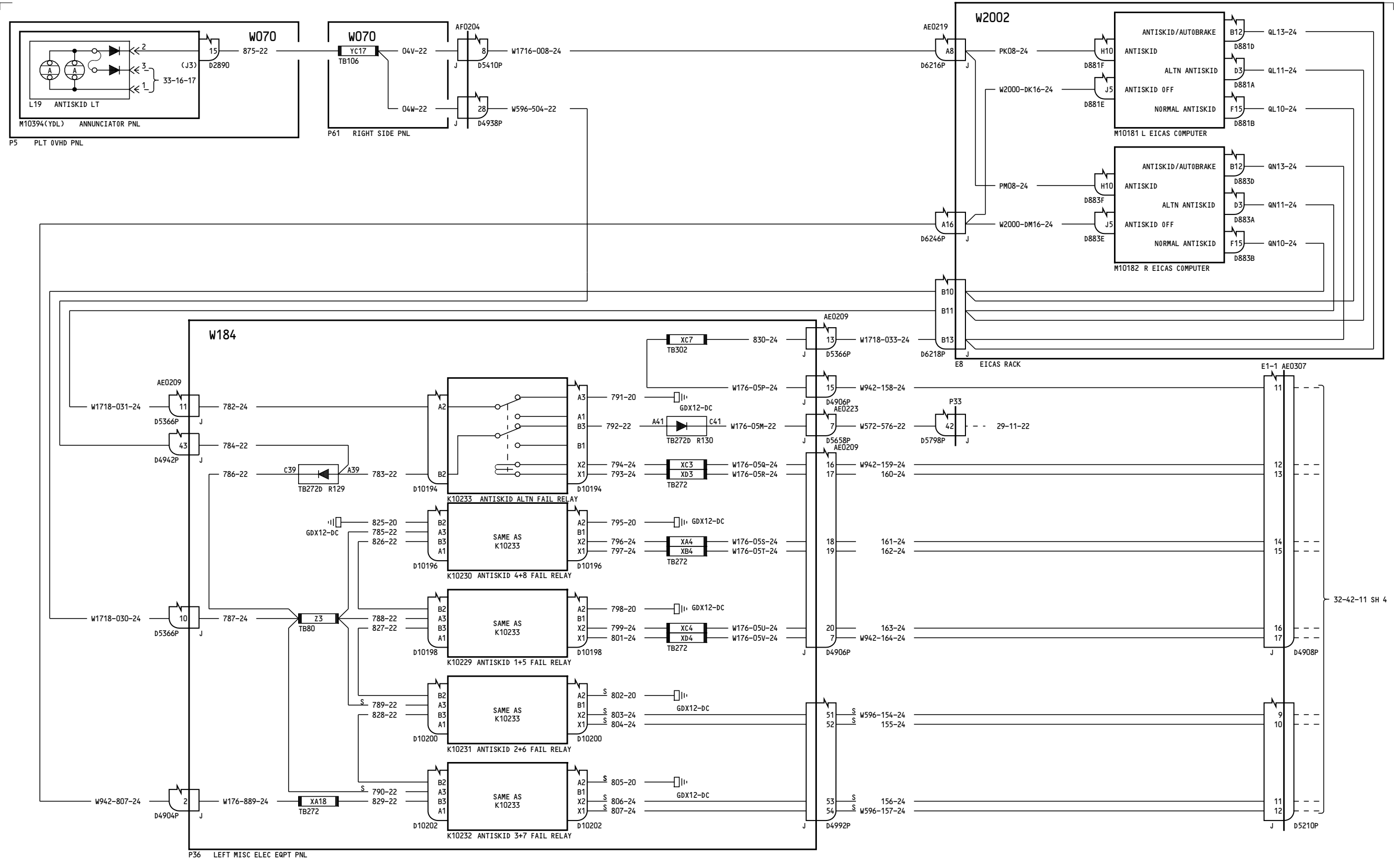

150-152

ANTISKID SYSTEM

32-42-11

Page 2.1  
Sheet 3  
Jan 21/2005

D280T132

32-42-11

Page 2.1  
Sheet 3  
Jan 21/2005

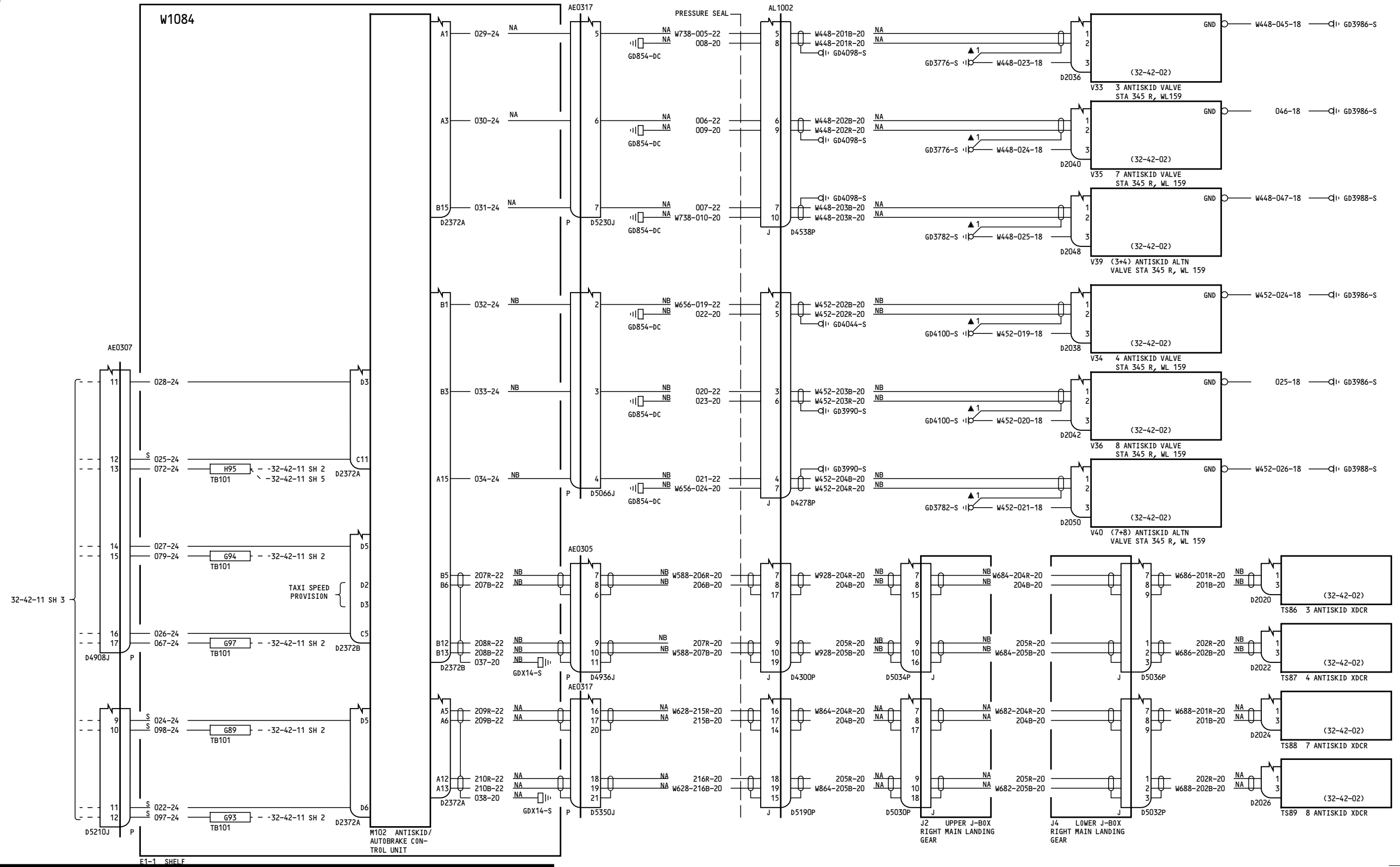

150-152

**ANTISKID SYSTEM**

D280T132

**32-42-11**

Page 2.1  
Sheet 4  
Jan 21/2005

**32-42-11**

Page 2.1  
Sheet 4  
Jan 21/2005

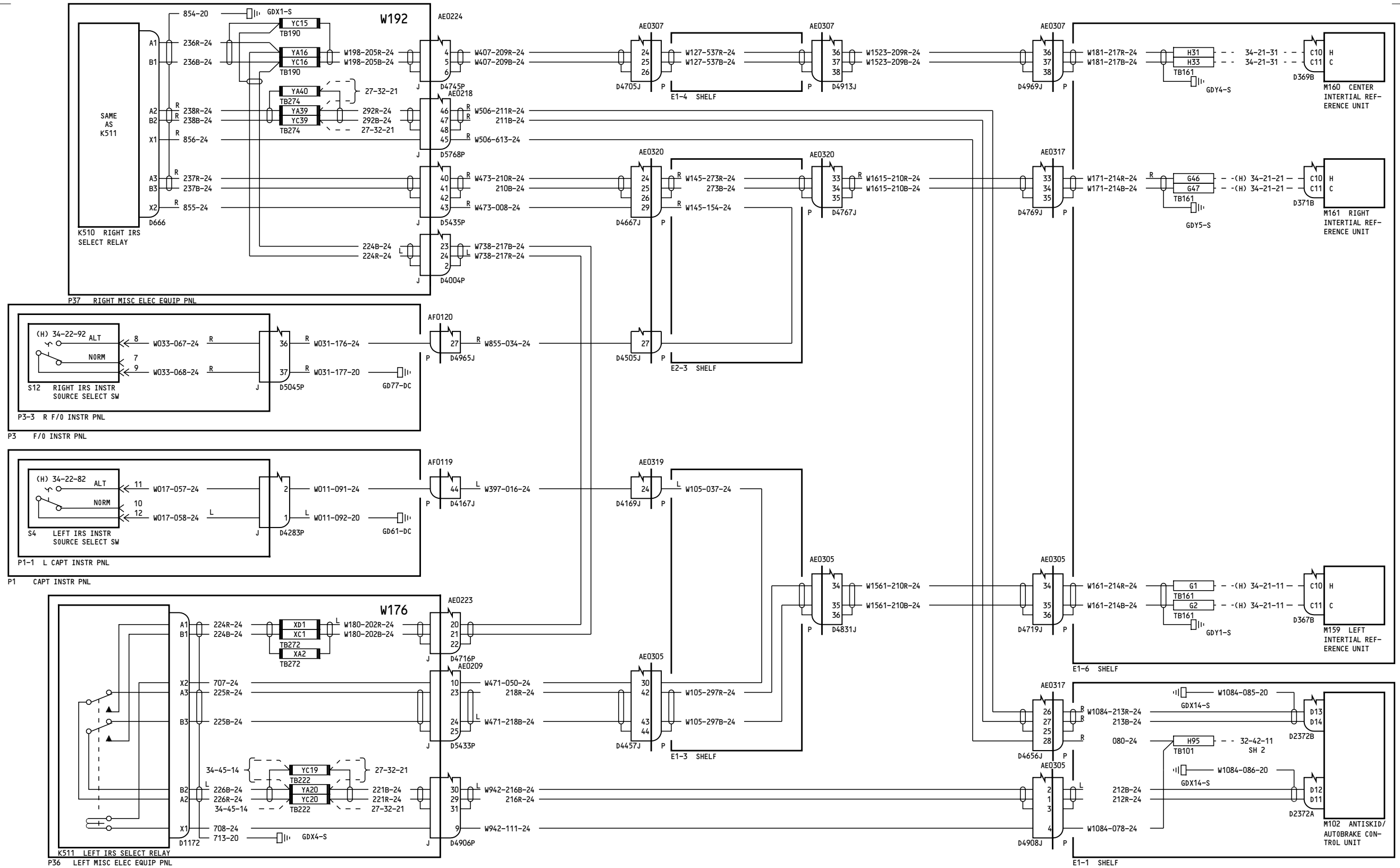

150-152

**ANTISKID SYSTEM**

**32-42-11**

Incorporates  
34-0091 R01

**32-42-11**

D280T132

Page 2.1  
Sheet 5  
Jan 21/2005

Page 2.1  
Sheet 5  
Jan 21/2005

76

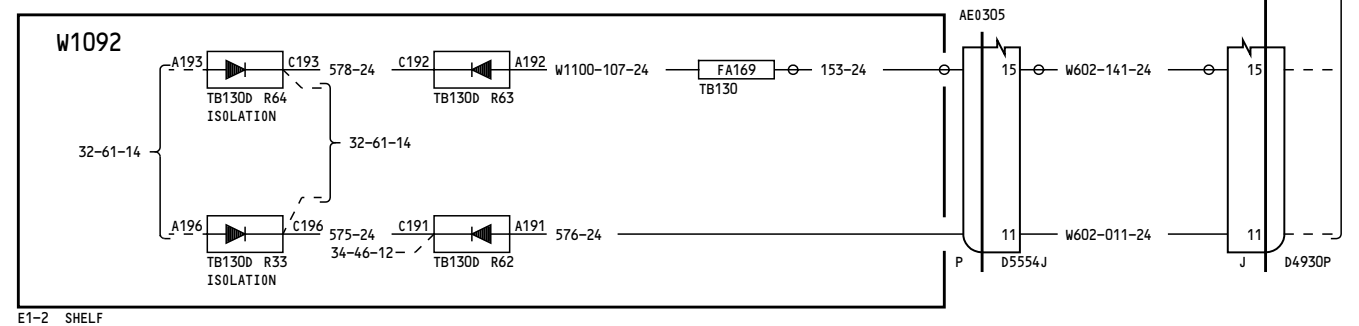
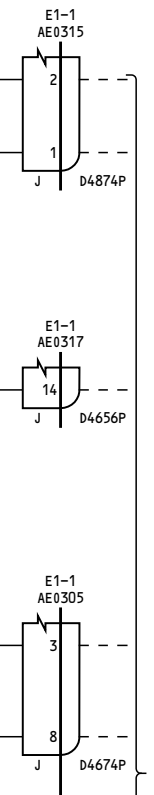
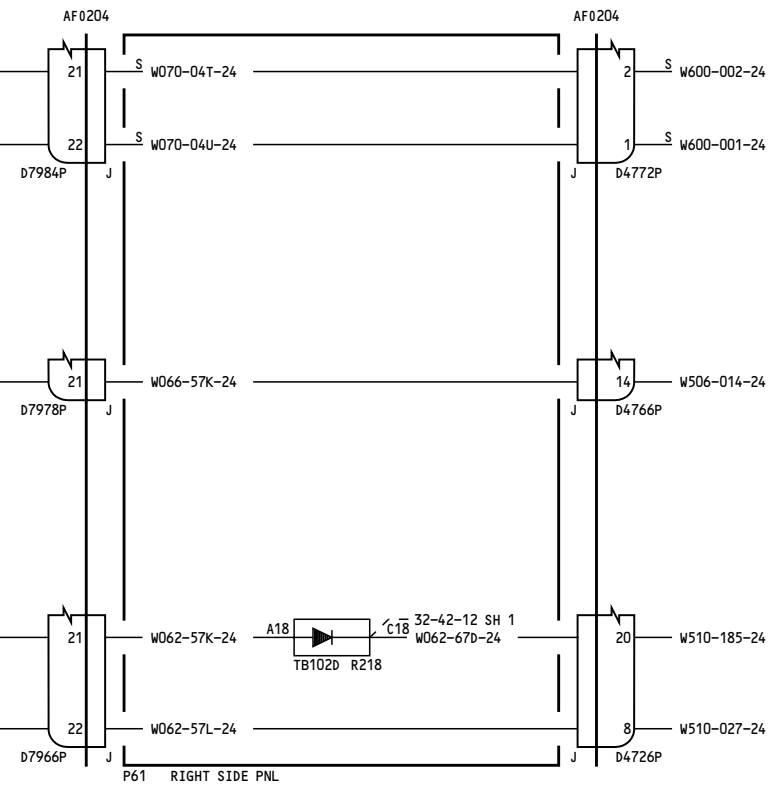
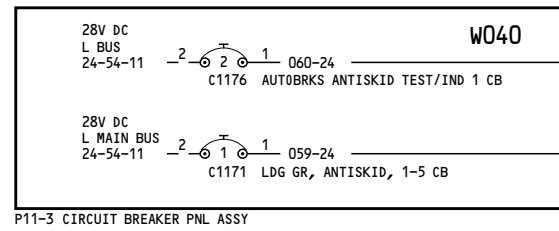
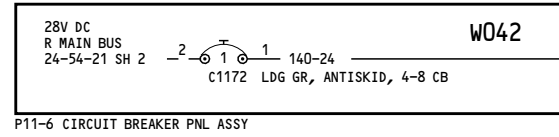
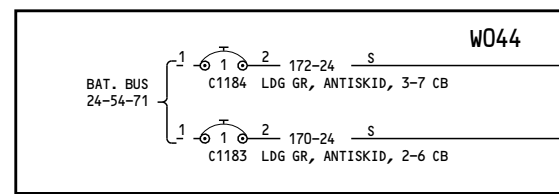

153-199

ANTISKID SYSTEM

D280T132

32-42-11

Page 3  
Sheet 1  
Mar 14/2007

32-42-11

Page 3  
Sheet 1  
Mar 14/2007

-A  
76

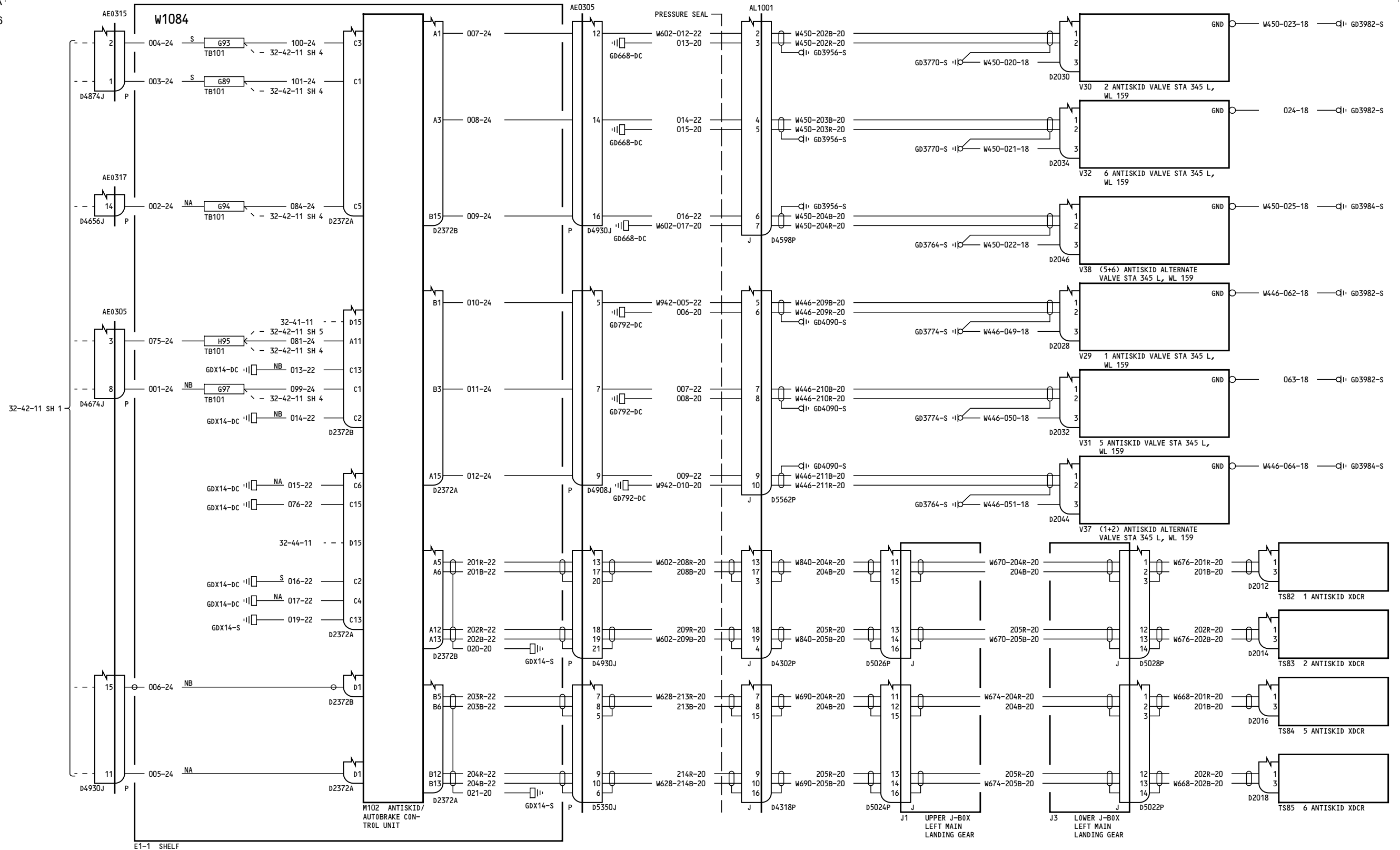

153-199

ANTISKID SYSTEM

32-42-11

Page 3  
Sheet 2  
Mar 14/2007

D280T132

32-42-11

Page 3  
Sheet 2  
Mar 14/2007

76

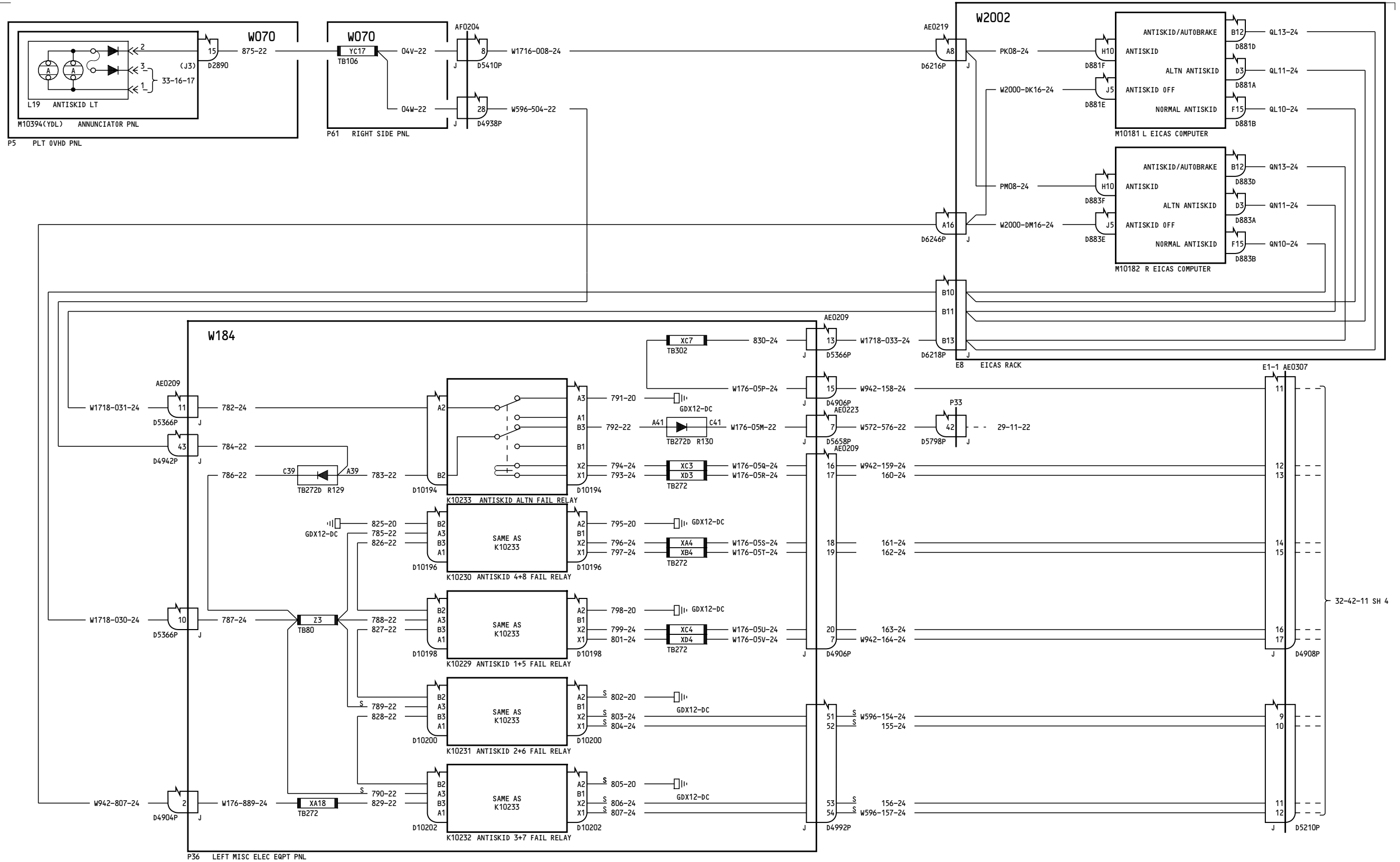

153-199

ANTISKID SYSTEM

32-42-11

Page 3  
Sheet 3  
Mar 14/2007

D280T132

32-42-11

Page 3  
Sheet 3  
Mar 14/2007

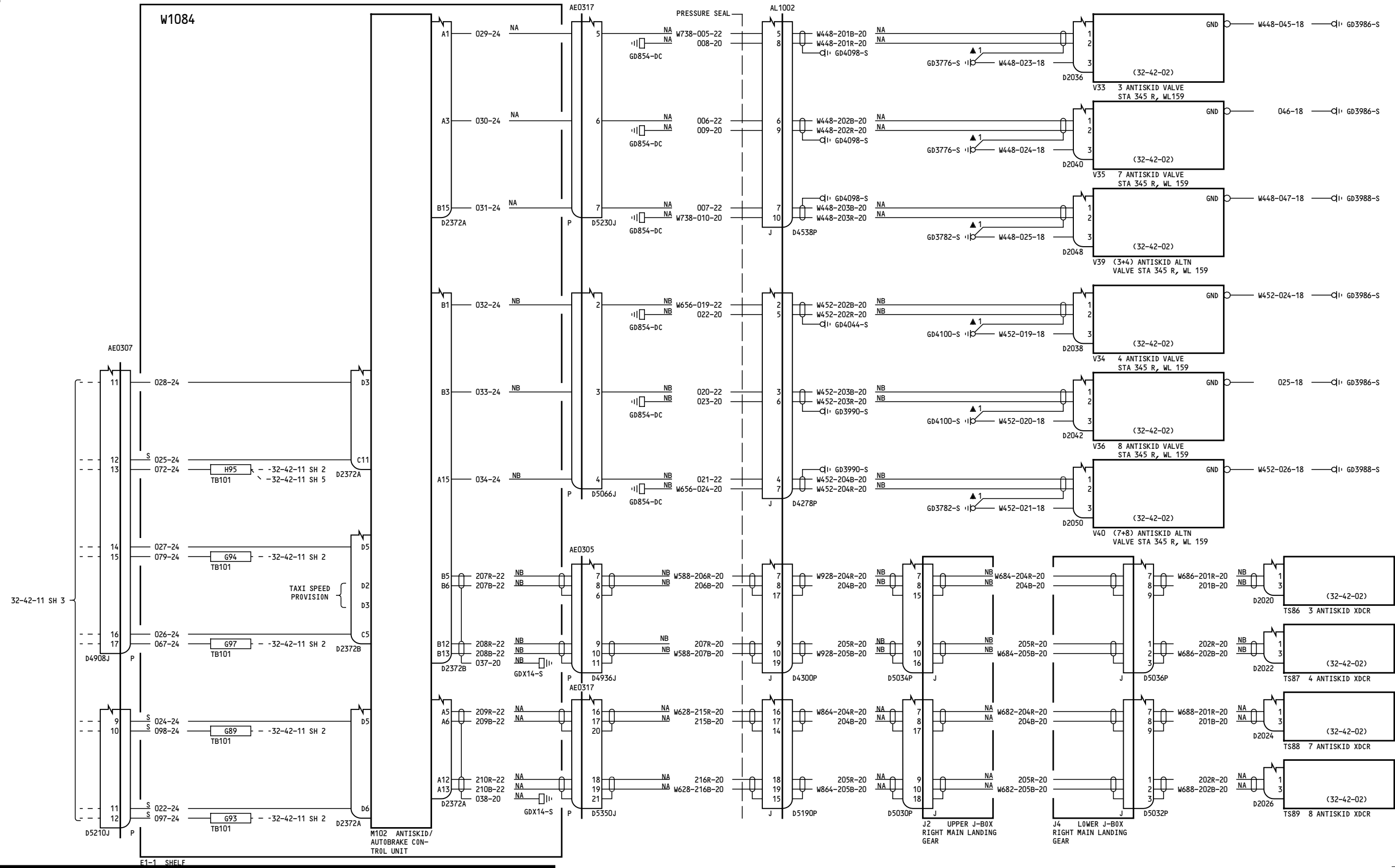

153-199

**ANTISKID SYSTEM**

D280T132

**32-42-11**

Page 3  
Sheet 4  
Mar 14/2007

**32-42-11**

Page 3  
Sheet 4  
Mar 14/2007

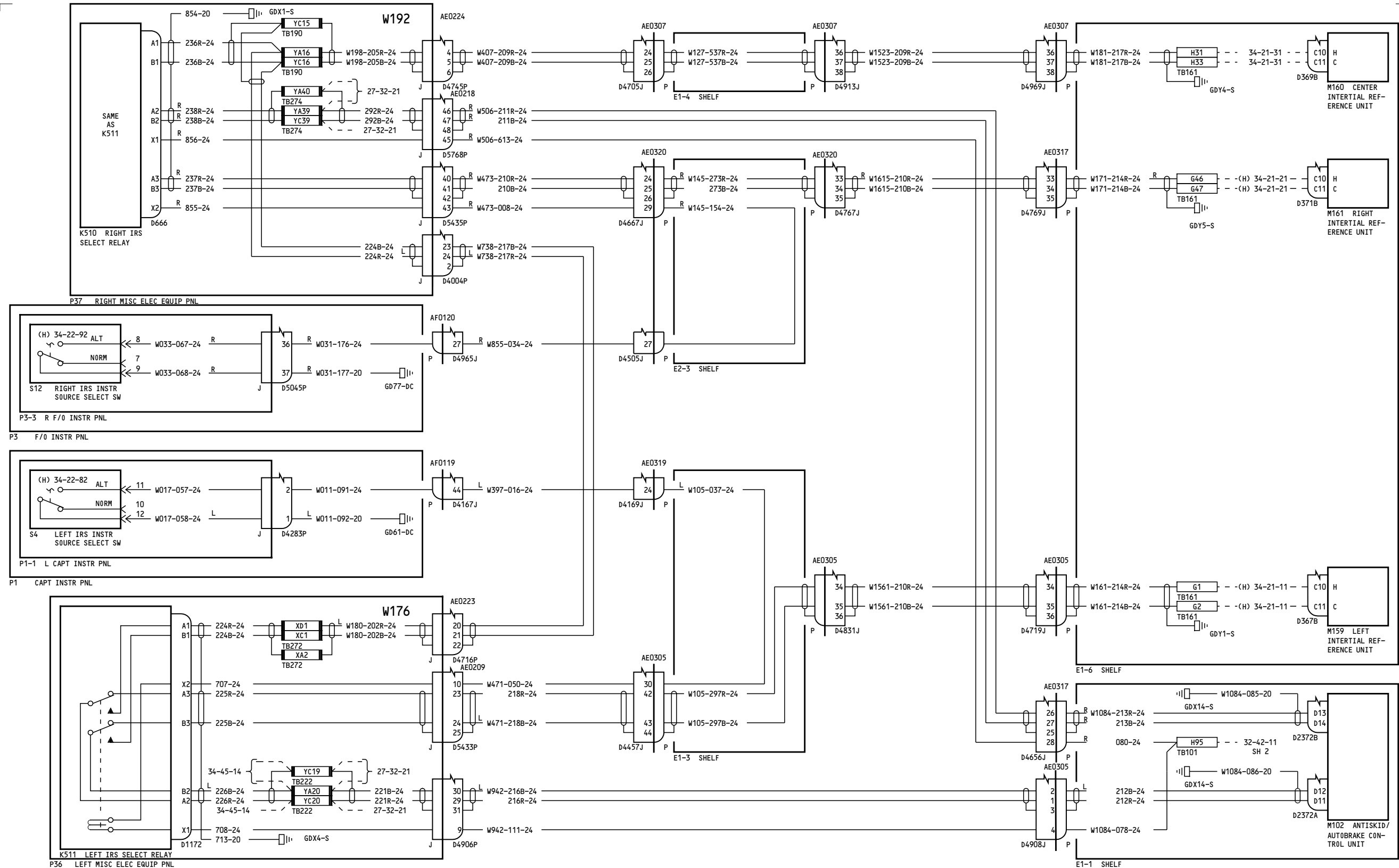

153-199

**ANTISKID SYSTEM**

**32-42-11**

**32-42-11**

BOEING PROPRIETARY - Copyright © - Unpublished Work - See title page for details.



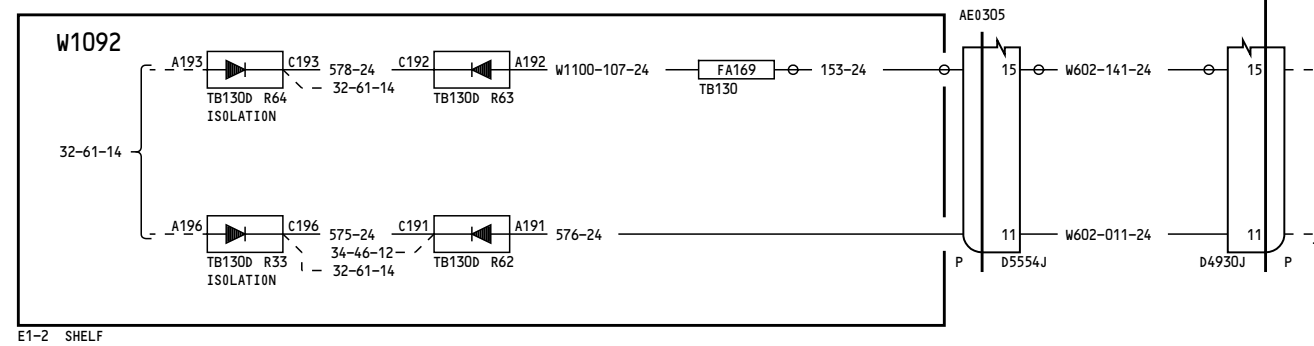
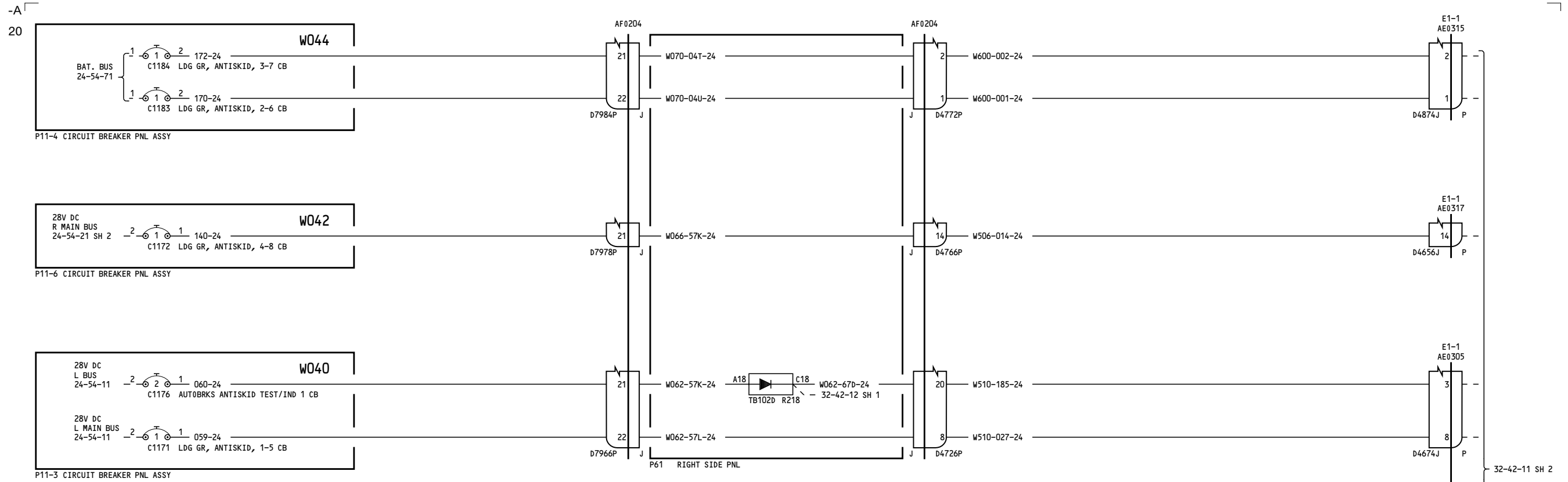

275-276

**ANTISKID SYSTEM**

D280T132

**32-42-11**

Page 4A  
 Sheet 1  
 Mar 14/2007

**32-42-11**

Page 4A  
 Sheet 1  
 Mar 14/2007

-B  
20

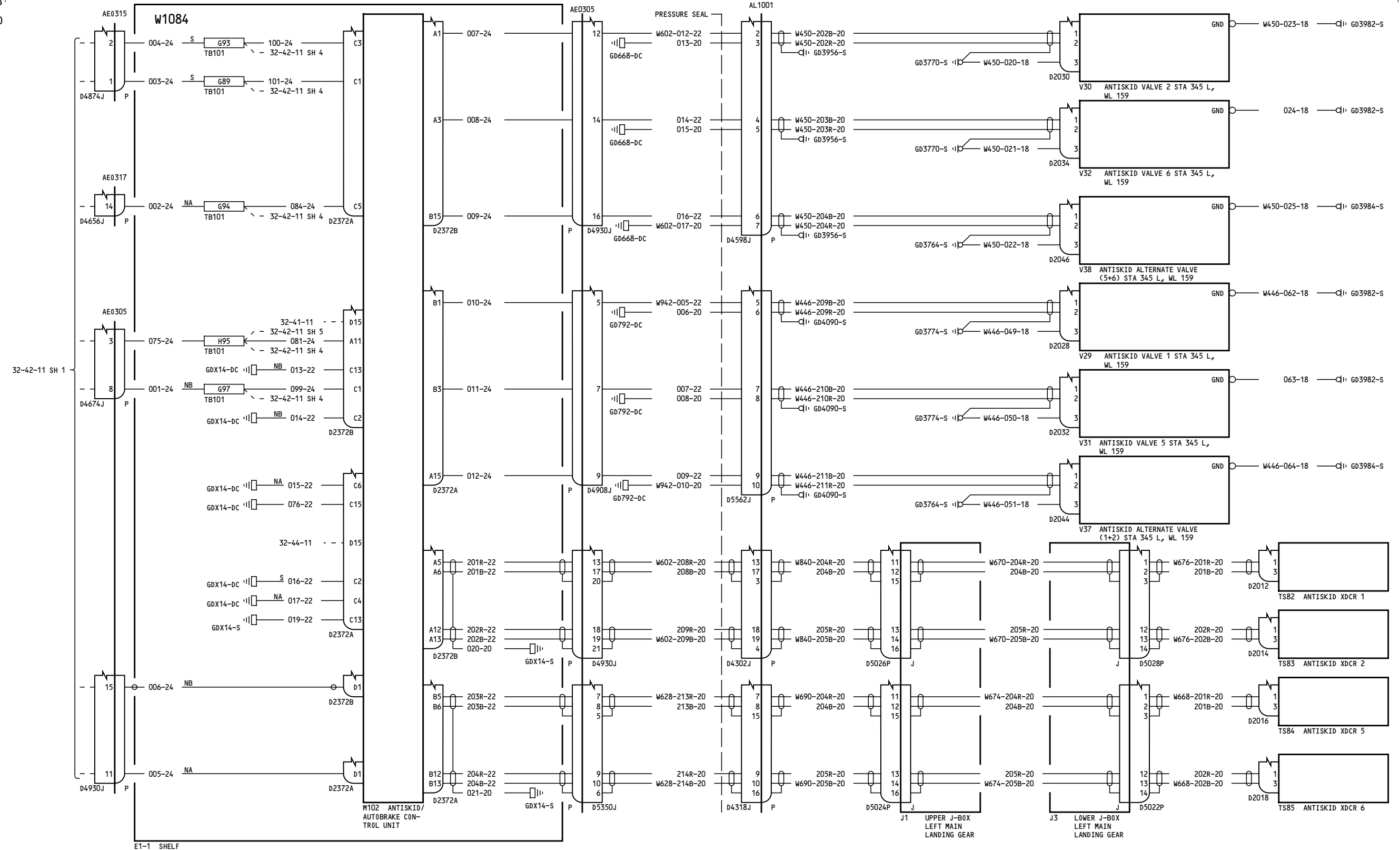

275-276

ANTISKID SYSTEM

32-42-11

Page 4A  
Sheet 2  
Mar 14/2007

D280T132

32-42-11

Page 4A  
Sheet 2  
Mar 14/2007

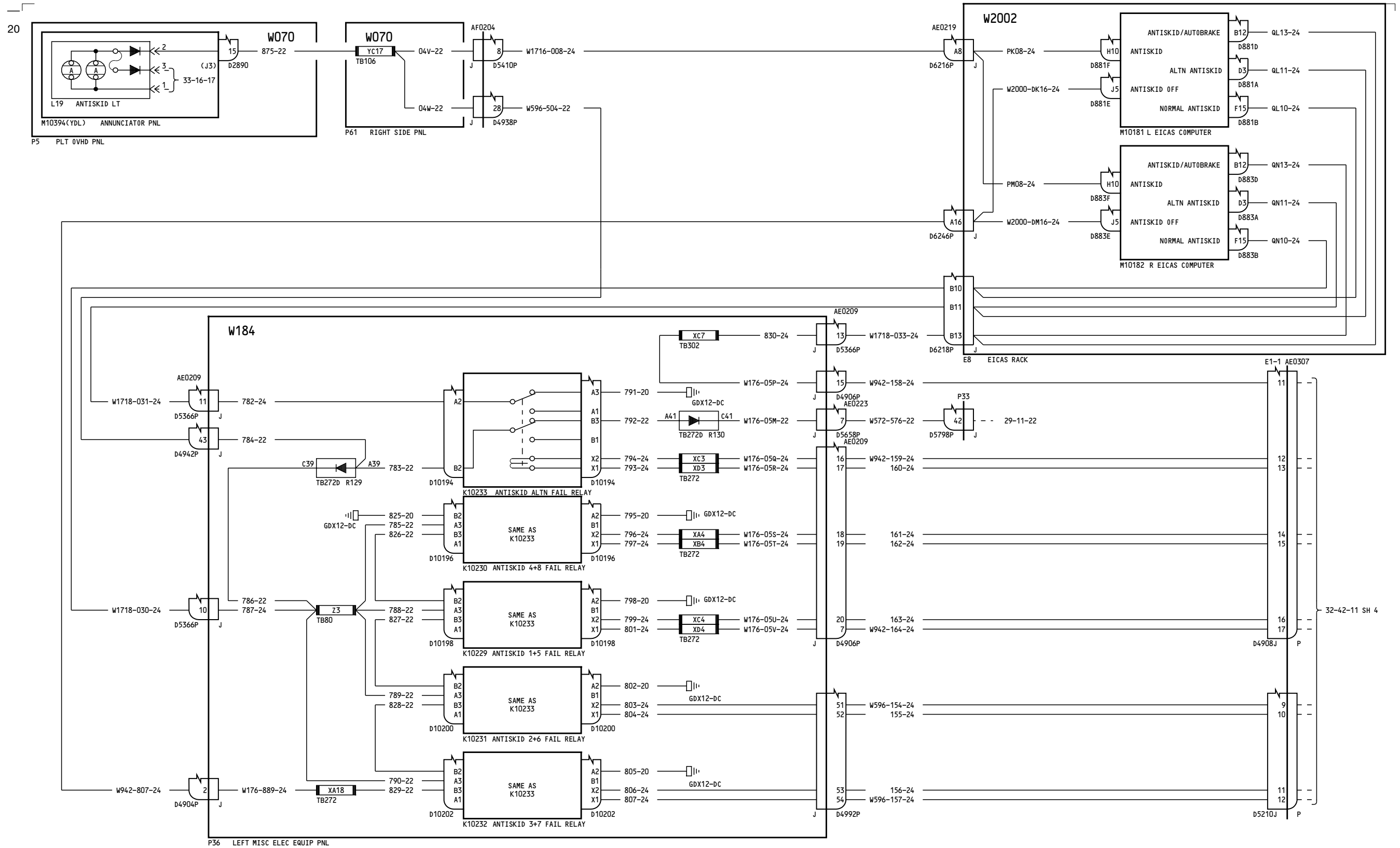

275-276

ANTISKID SYSTEM

32-42-11

Page 4A  
Sheet 3  
Mar 14/2007

D280T132

32-42-11

Page 4A  
Sheet 3  
Mar 14/2007

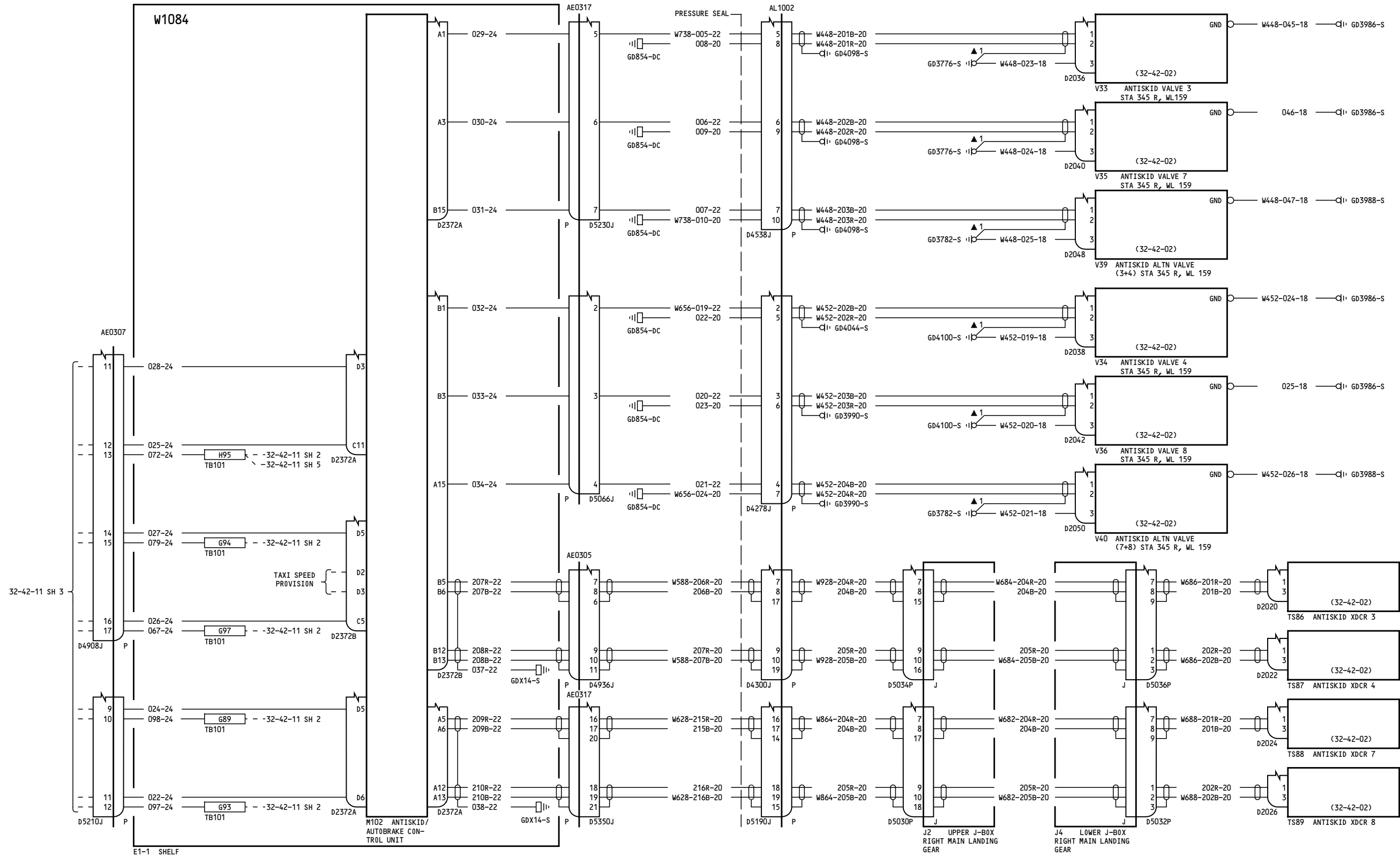

275-276

ANTISKID SYSTEM

32-42-11

Page 4A  
Sheet 4  
Mar 14/2007

D280T132

32-42-11

Page 4A  
Sheet 4  
Mar 14/2007

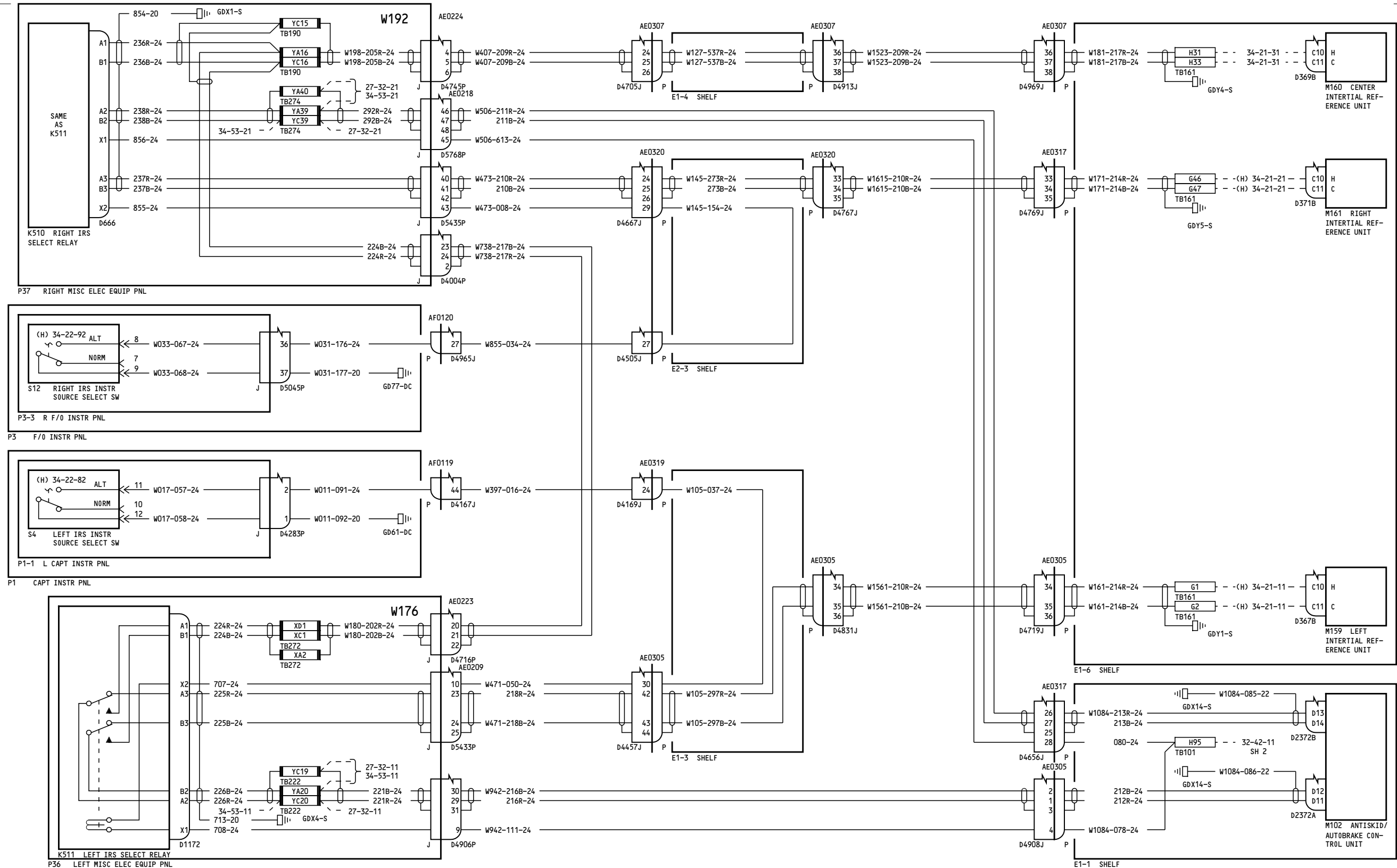

275-276

ANTISKID SYSTEM

32-42-11

Incorporates EOC EEB34-0360-02

32-42-11

D280T132

Page 4A  
Sheet 5  
Mar 14/2007

Page 4A  
Sheet 5  
Mar 14/2007

76

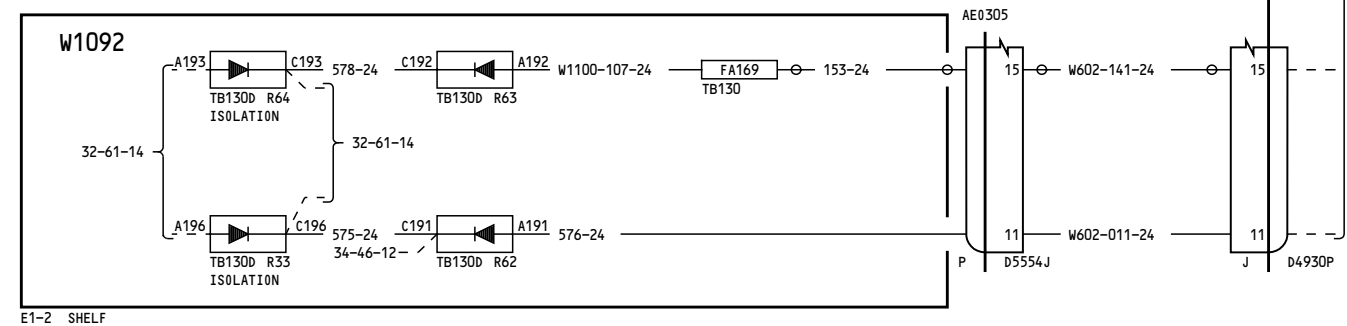
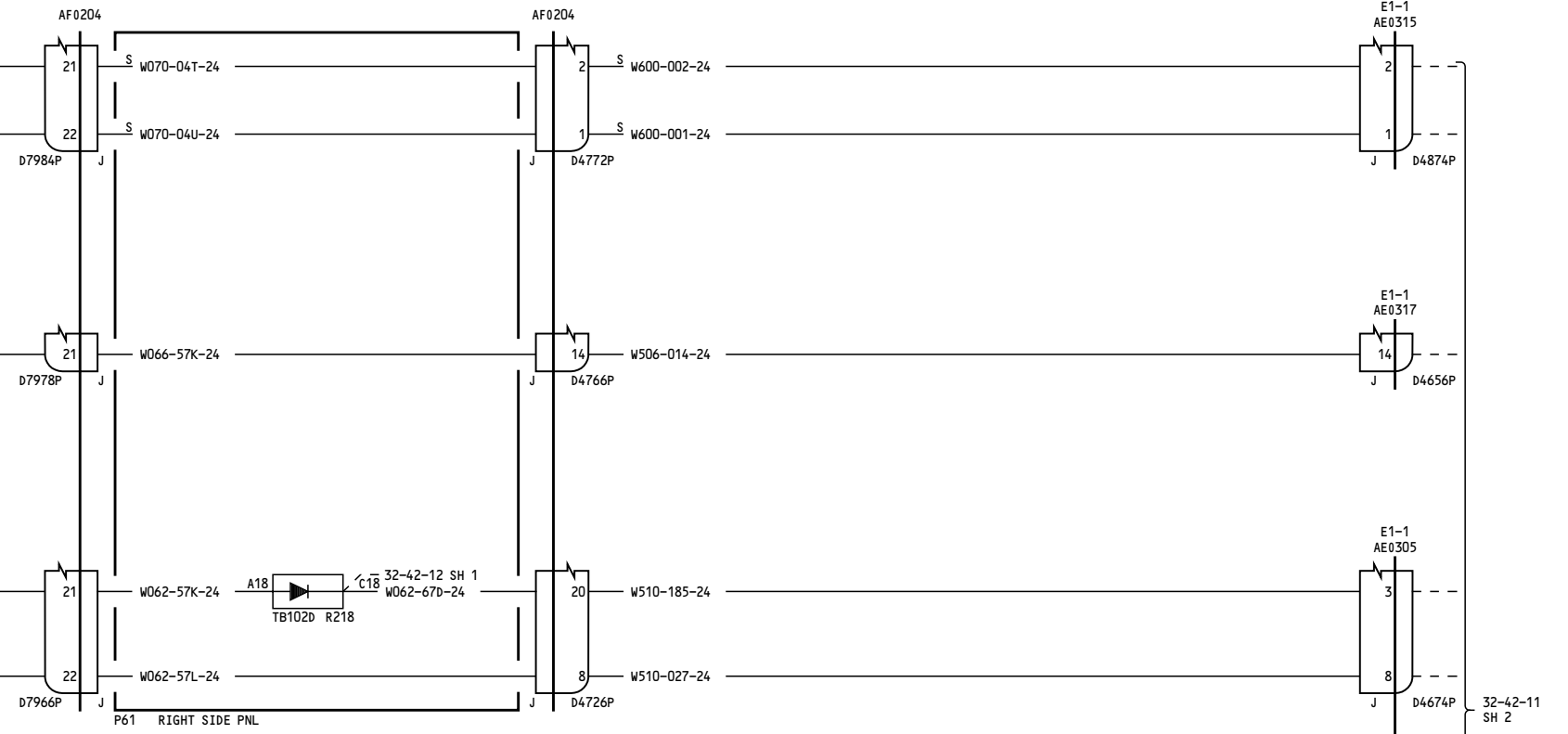
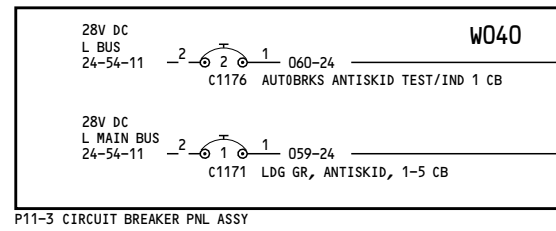
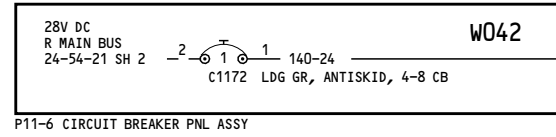
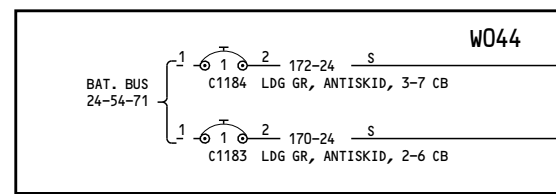

277-280	<b>ANTISKID SYSTEM</b>  D280T132
---------	--

BOEING PROPRIETARY - Copyright © - Unpublished Work - See title page for details.

-A  
76

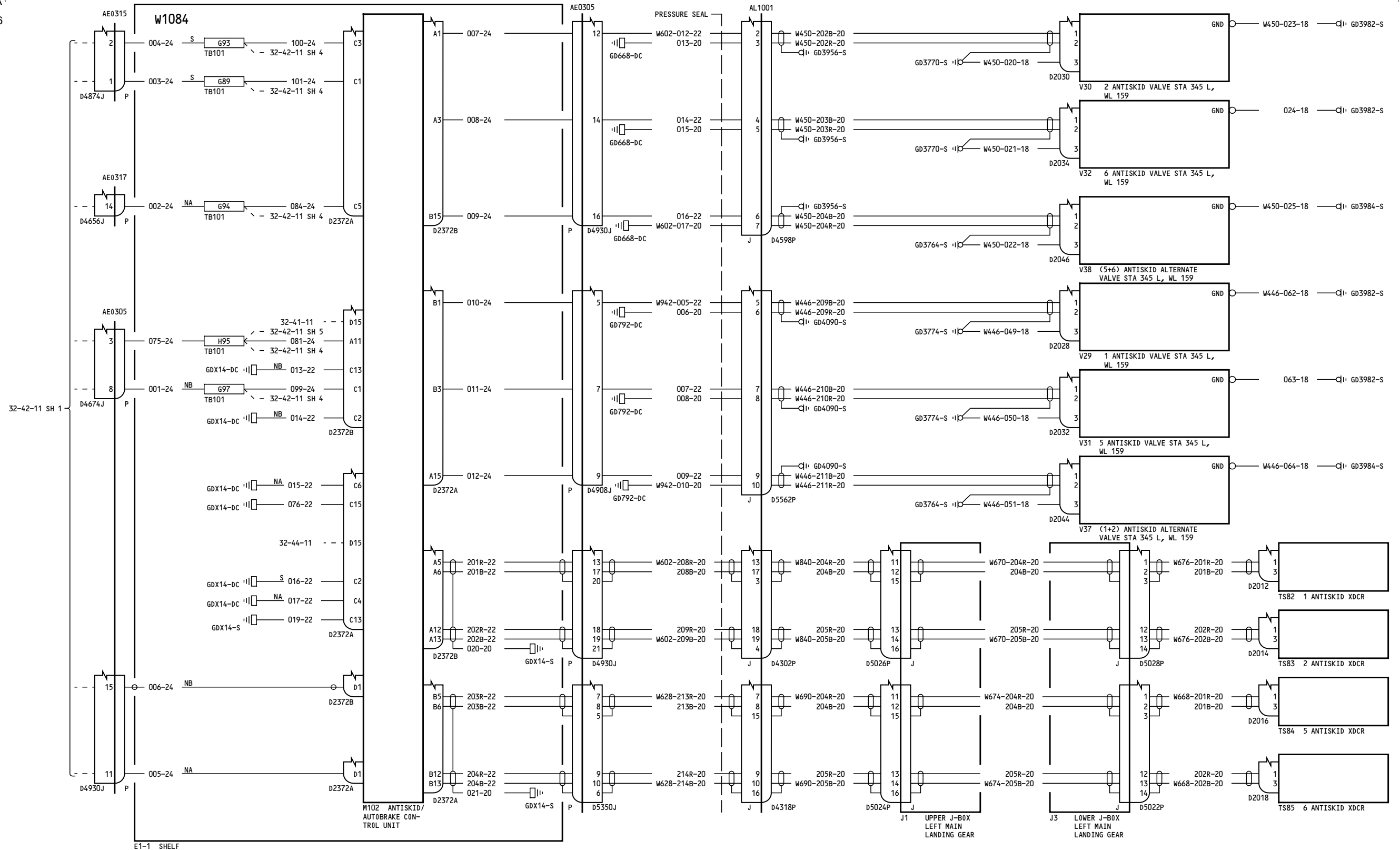

277-280

ANTISKID SYSTEM

32-42-11

Page 5A  
Sheet 2  
Mar 14/2007

D280T132

32-42-11

Page 5A  
Sheet 2  
Mar 14/2007

76

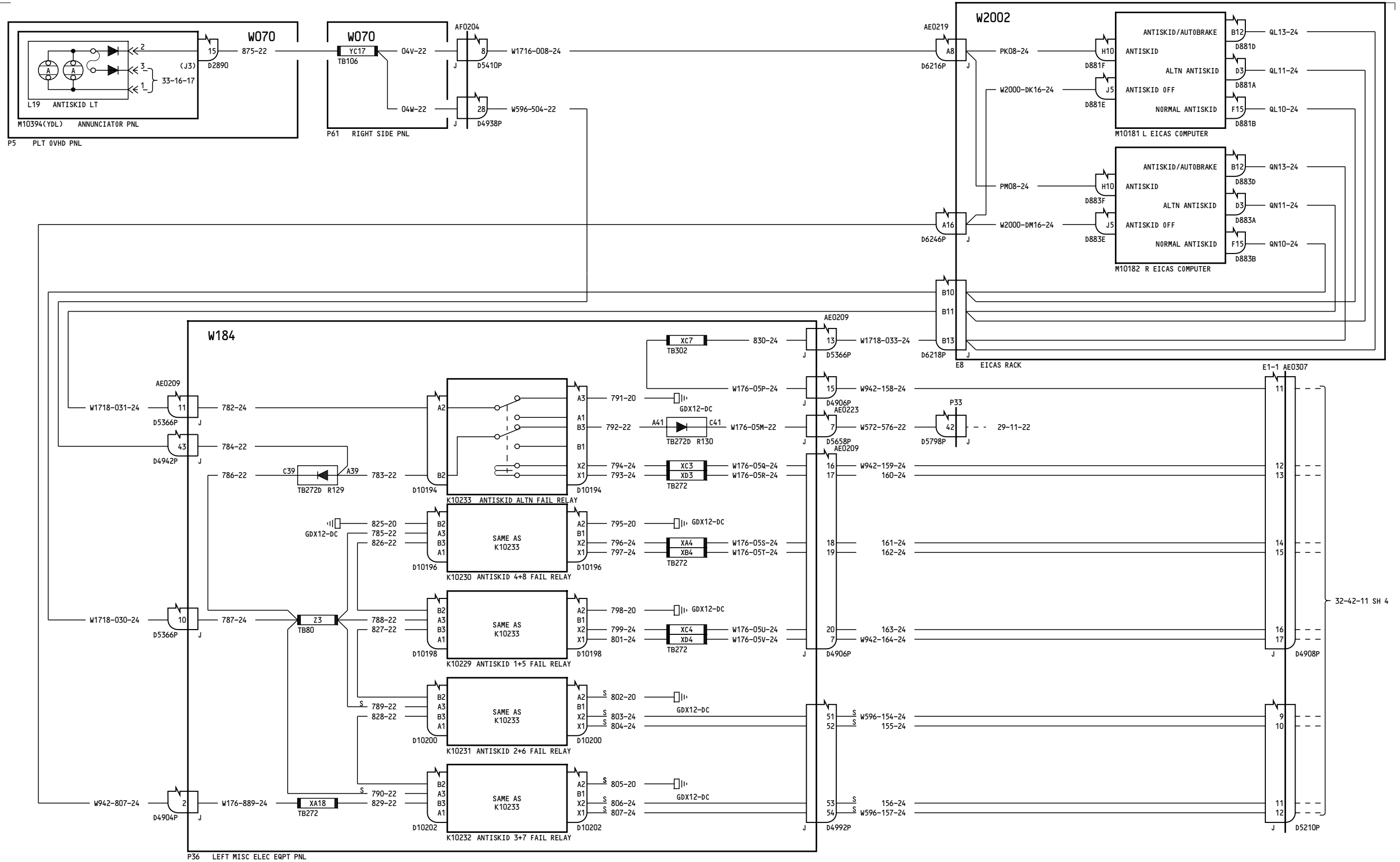

277-280

ANTISKID SYSTEM

32-42-11

Page 5A  
Sheet 3  
Mar 14/2007

D280T132

32-42-11

Page 5A  
Sheet 3  
Mar 14/2007



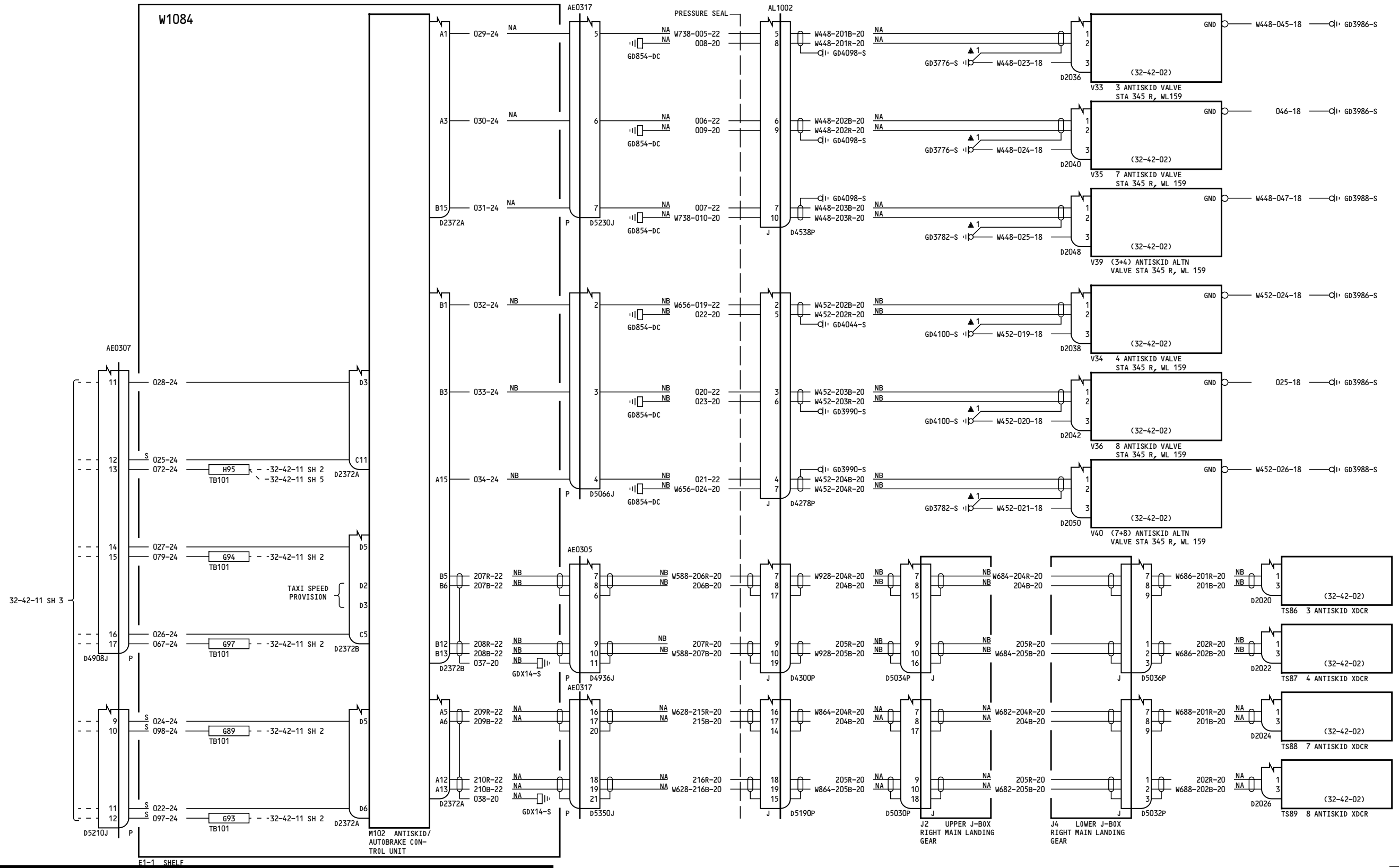

277-280

**ANTISKID SYSTEM**  
D280T132

**32-42-11**

Page 5A  
Sheet 4  
Mar 14/2007

**32-42-11**

Page 5A  
Sheet 4  
Mar 14/2007

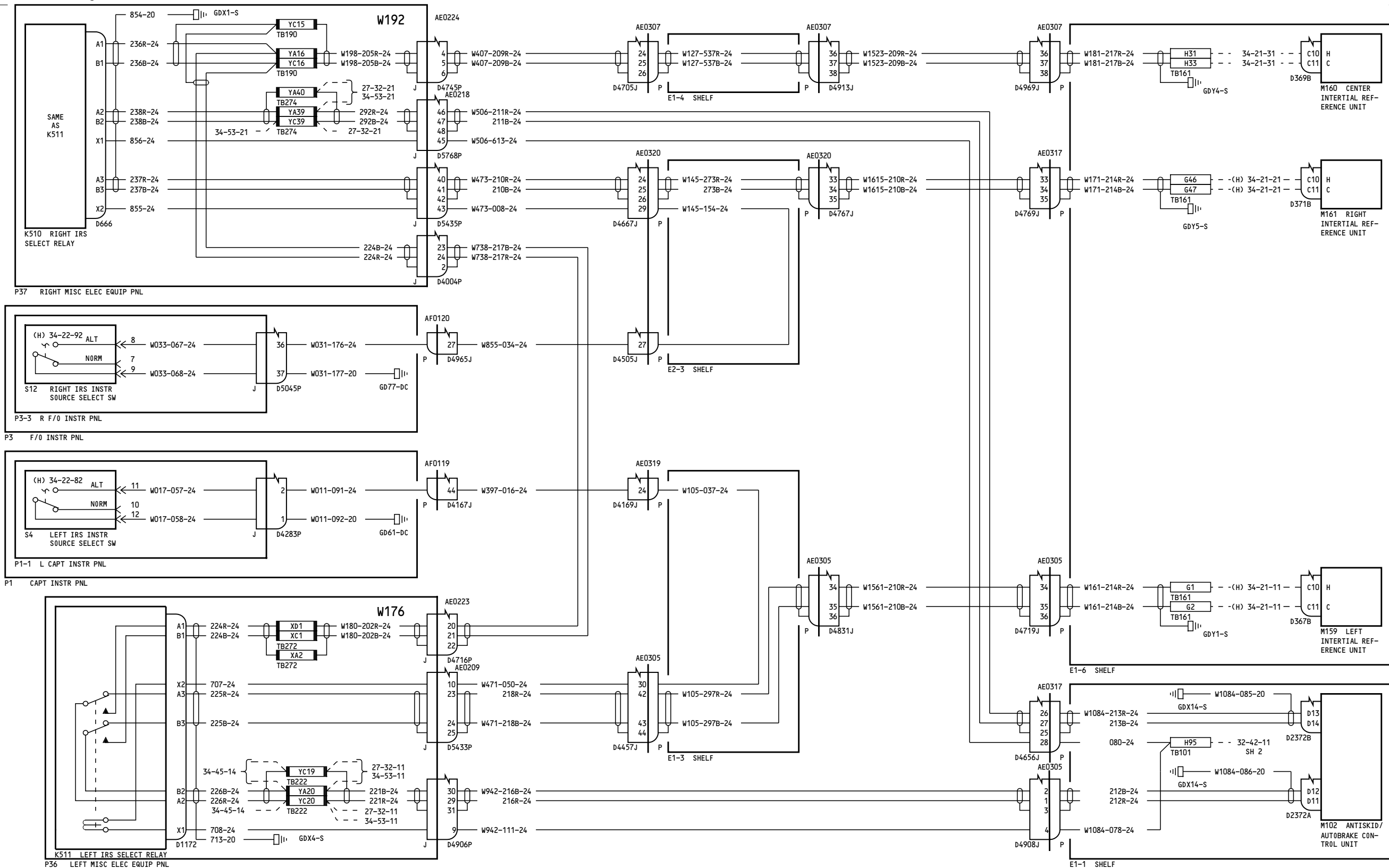

277-280

ANTISKID SYSTEM

32-42-11

Incorporates EOC EEB34-0360-02

32-42-11

D280T132

Page 5A Sheet 5 Mar 14/2007

Page 5A Sheet 5 Mar 14/2007

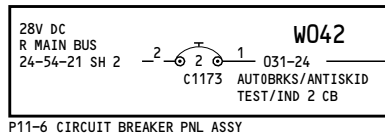

P11-6 CIRCUIT BREAKER PNL ASSY

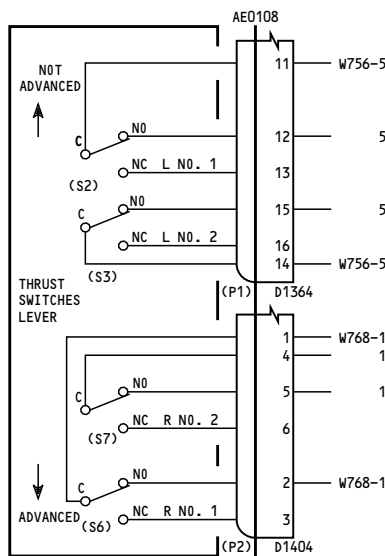

M966 MICROSWITCH PACK AUTO-THROTTLE ASSY

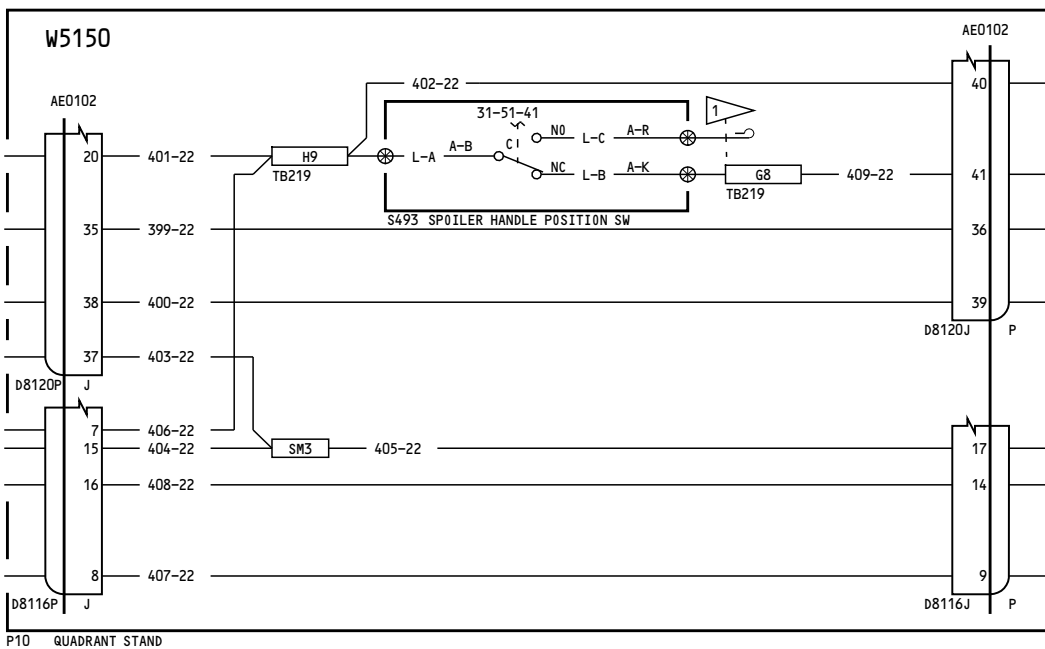

P10 QUADRANT STAND

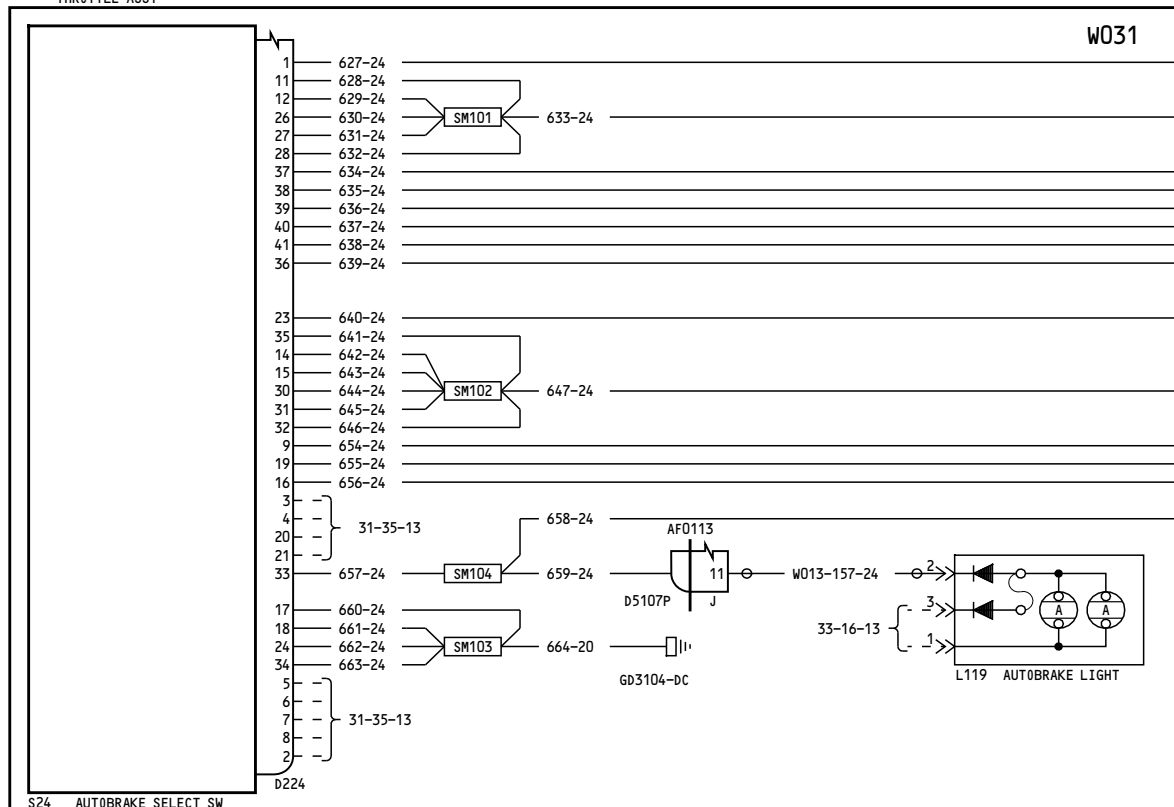

P1-3 R CAPT INSTR PNL

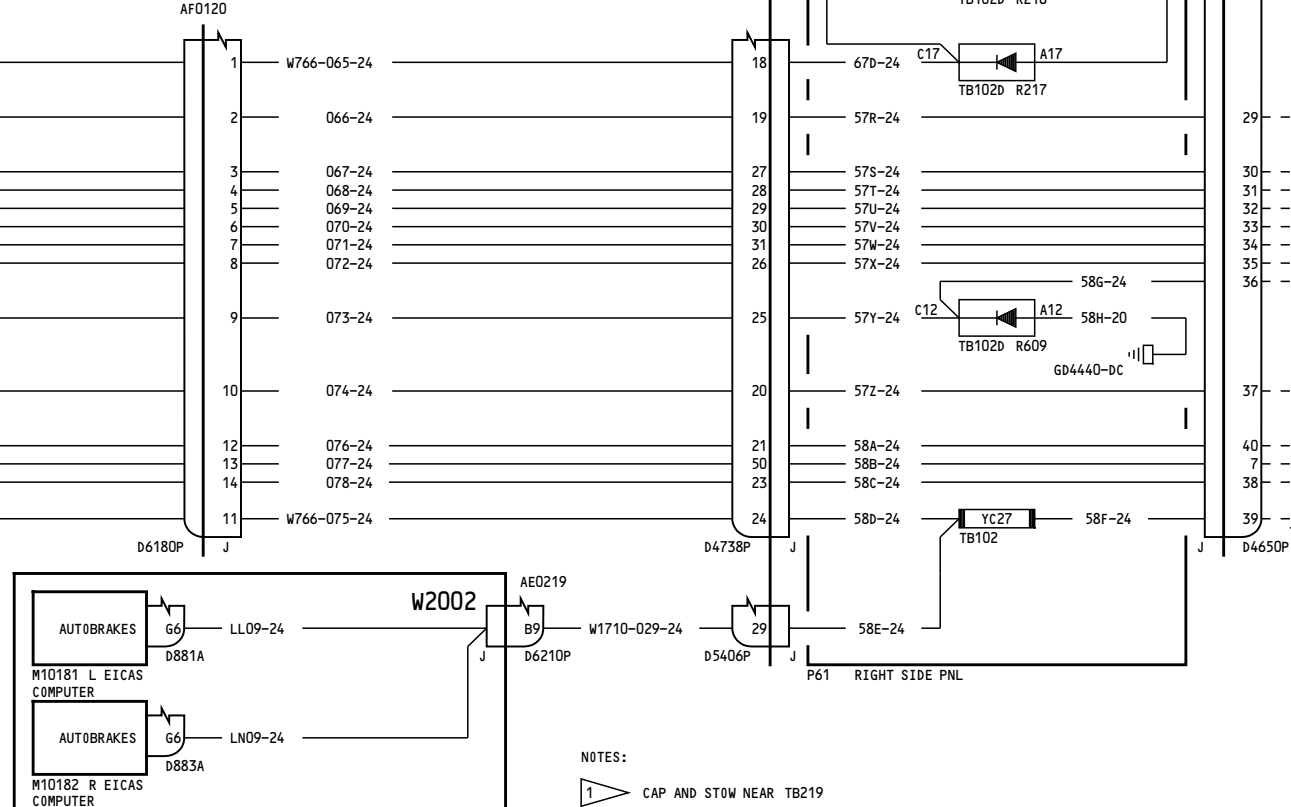

E8 EICAS RACK

NOTES:

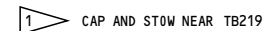

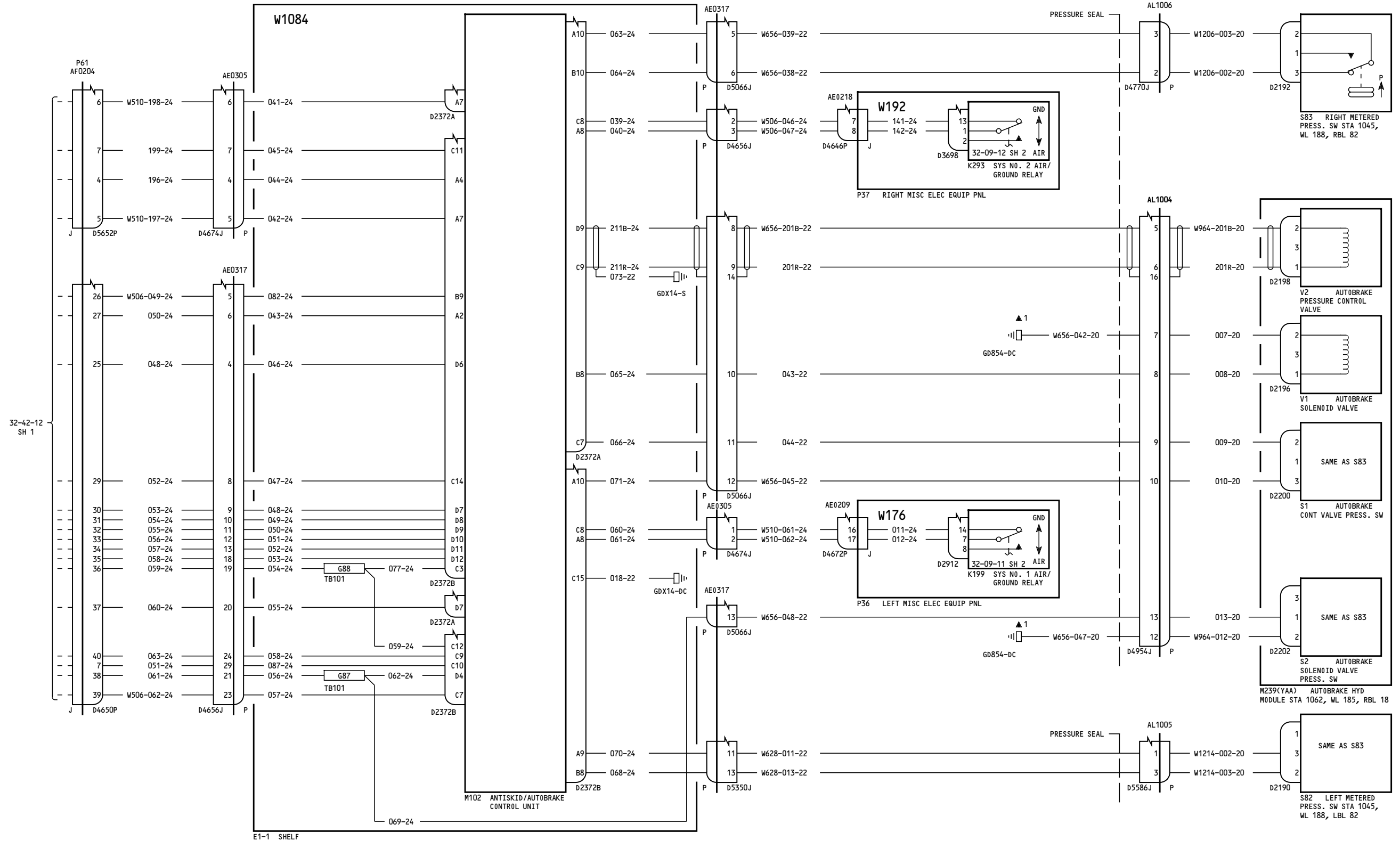

050-099, 150-199

**AUTOBRAKE SYSTEM**

**32-42-12**

Page 1  
Sheet 2  
Jan 21/2005

D280T132

**32-42-12**

Page 1  
Sheet 2  
Jan 21/2005

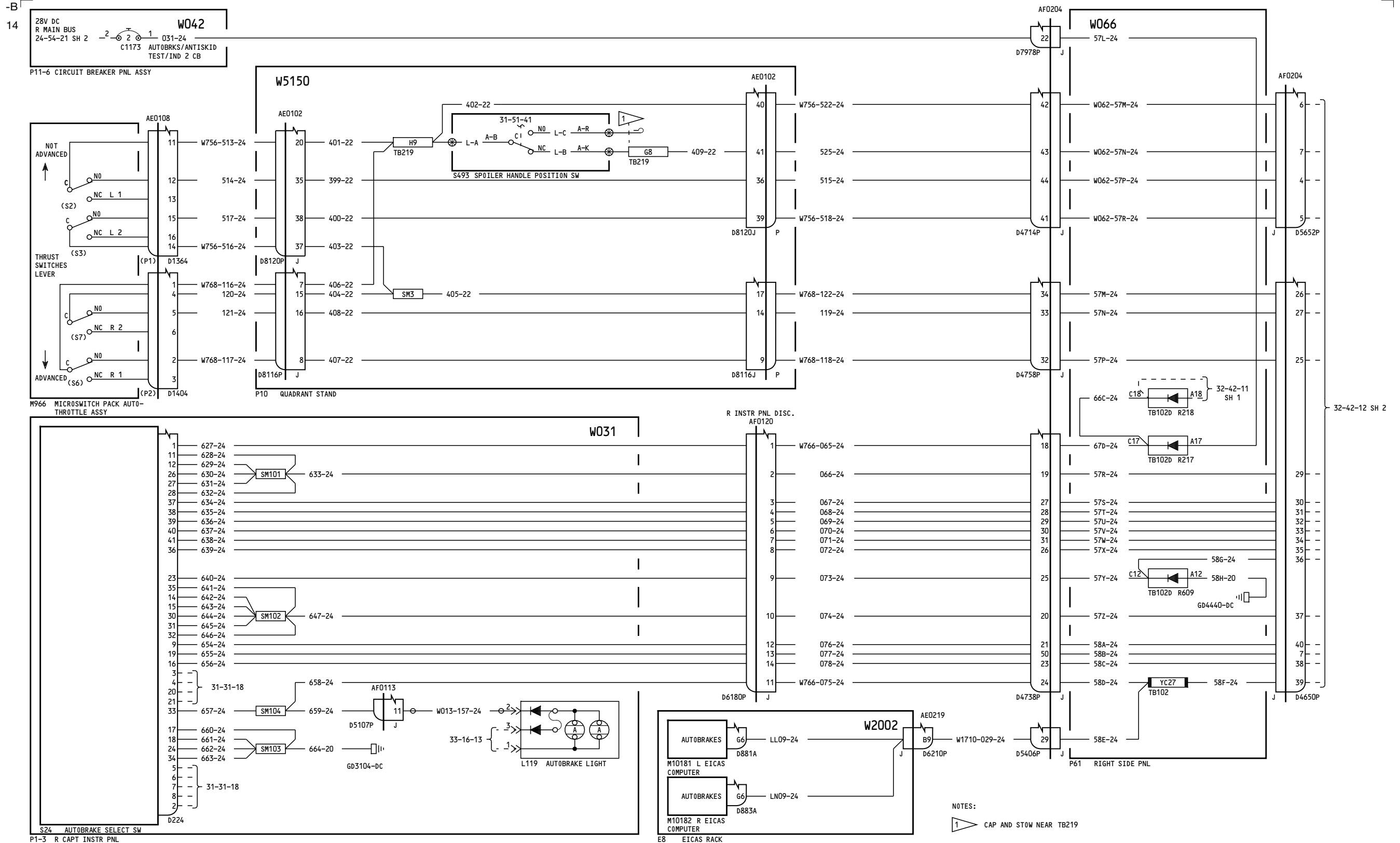

275-299

AUTOBRAKE SYSTEM

32-42-12

Page 2  
Sheet 1  
Jan 21/2005

D280T132

32-42-12

Page 2  
Sheet 1  
Jan 21/2005

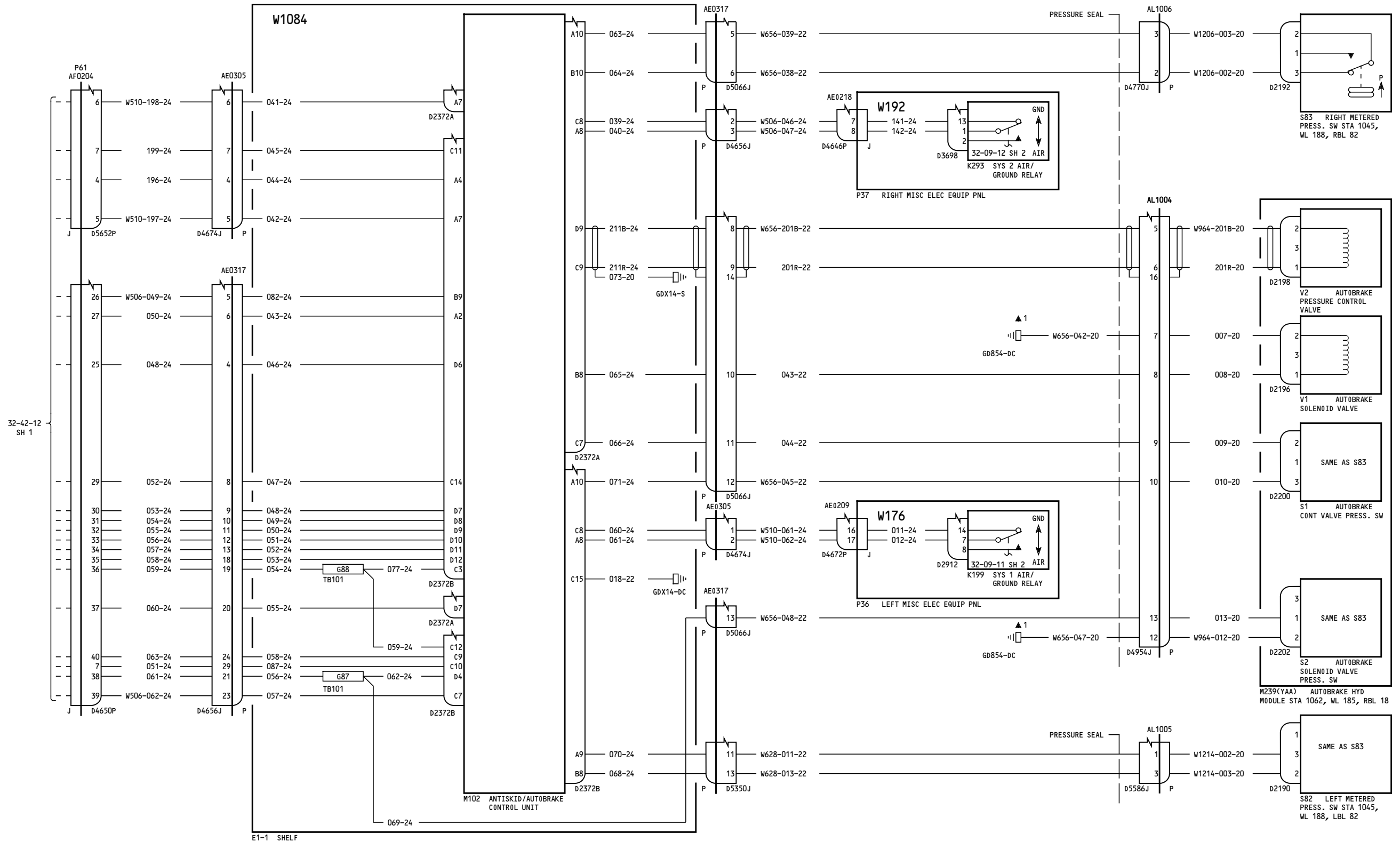

275-299

AUTOBRAKE SYSTEM

32-42-12

Page 2  
Sheet 2  
Jan 21/2005

D280T132

32-42-12

Page 2  
Sheet 2  
Jan 21/2005

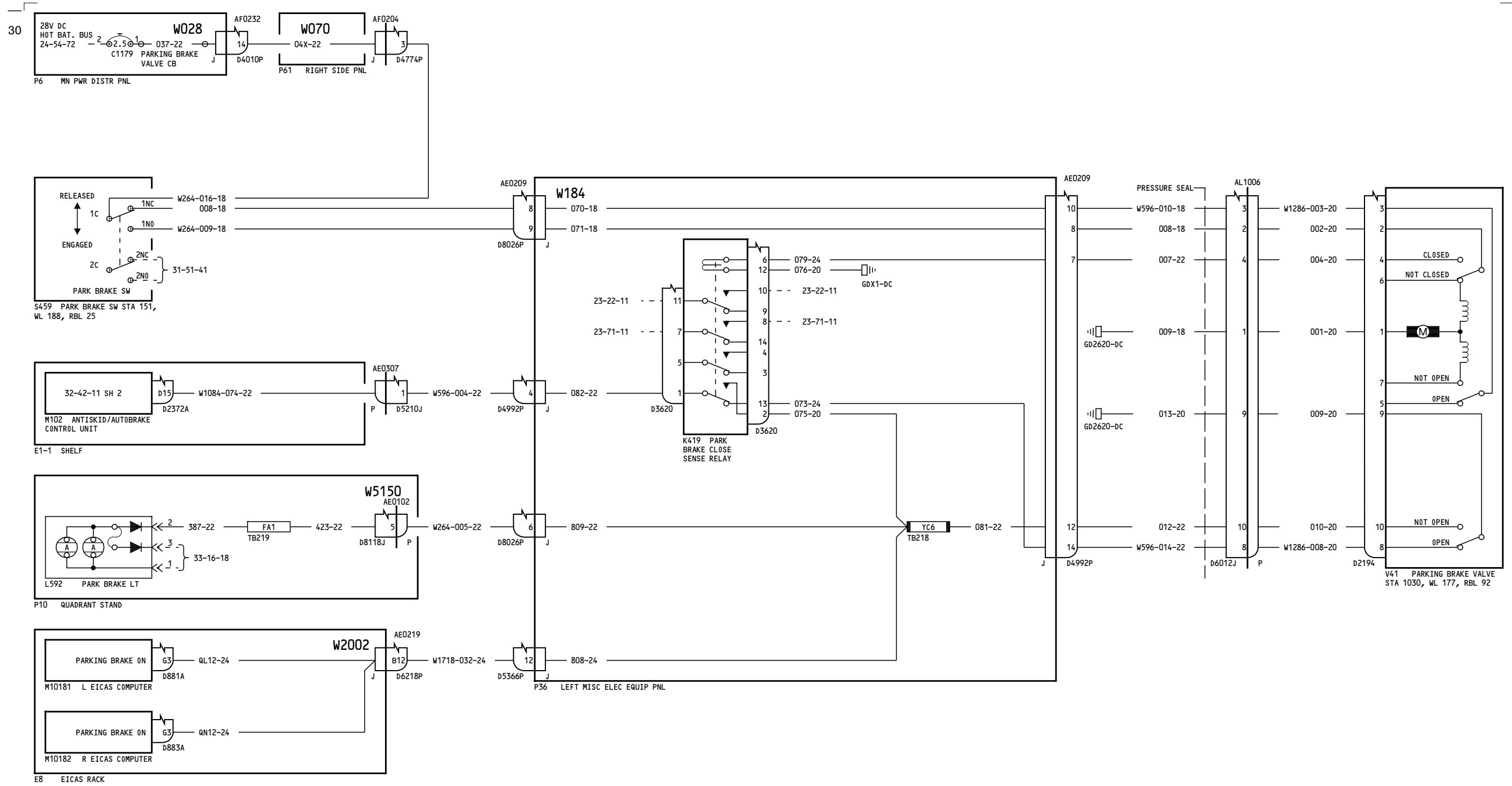

050-099

**PARKING BRAKE SYSTEM**

**32-44-11**

Page 1

D280T132

Jan 21/2005

**32-44-11**

Page 1

Jan 21/2005

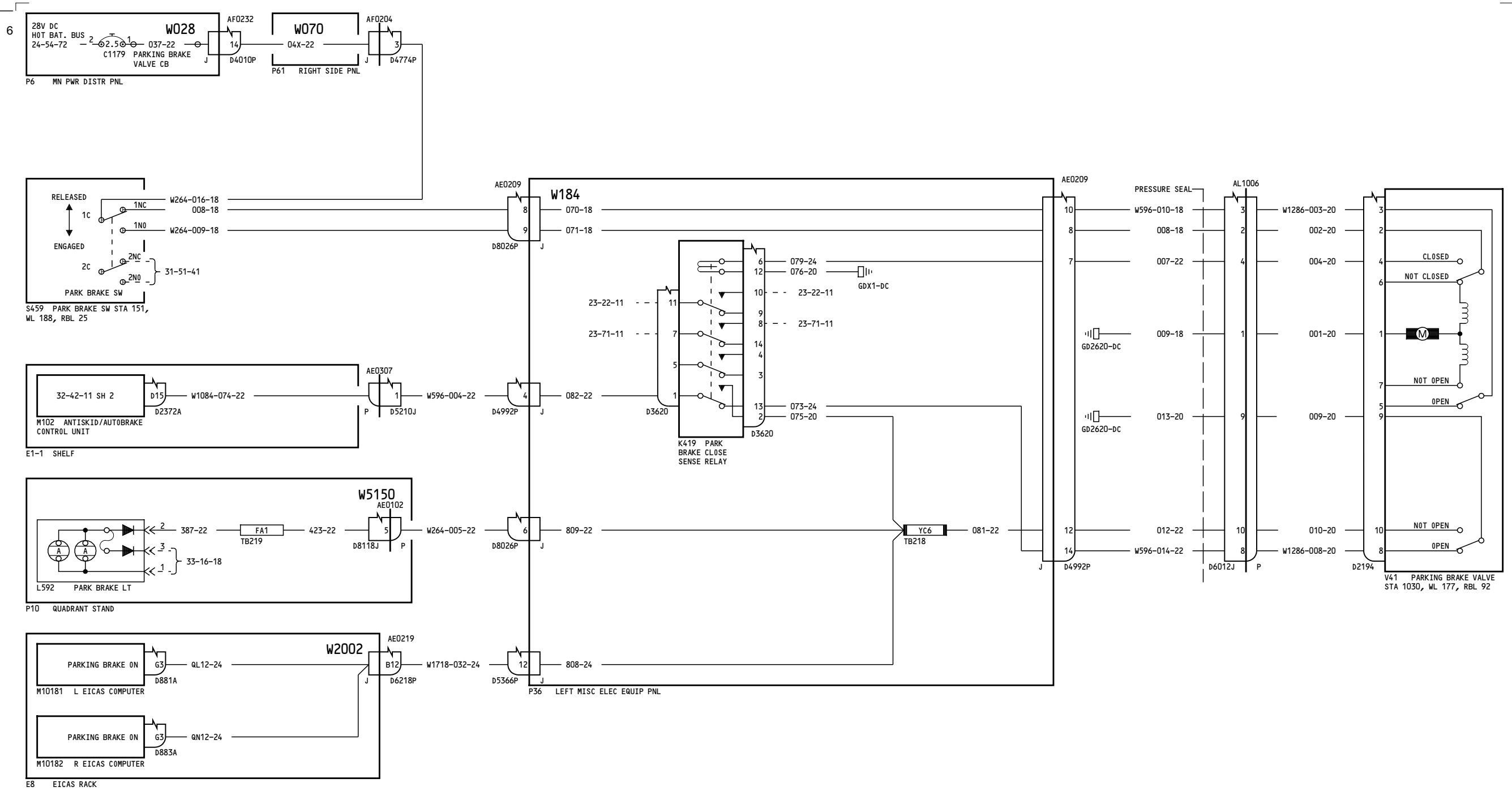



2

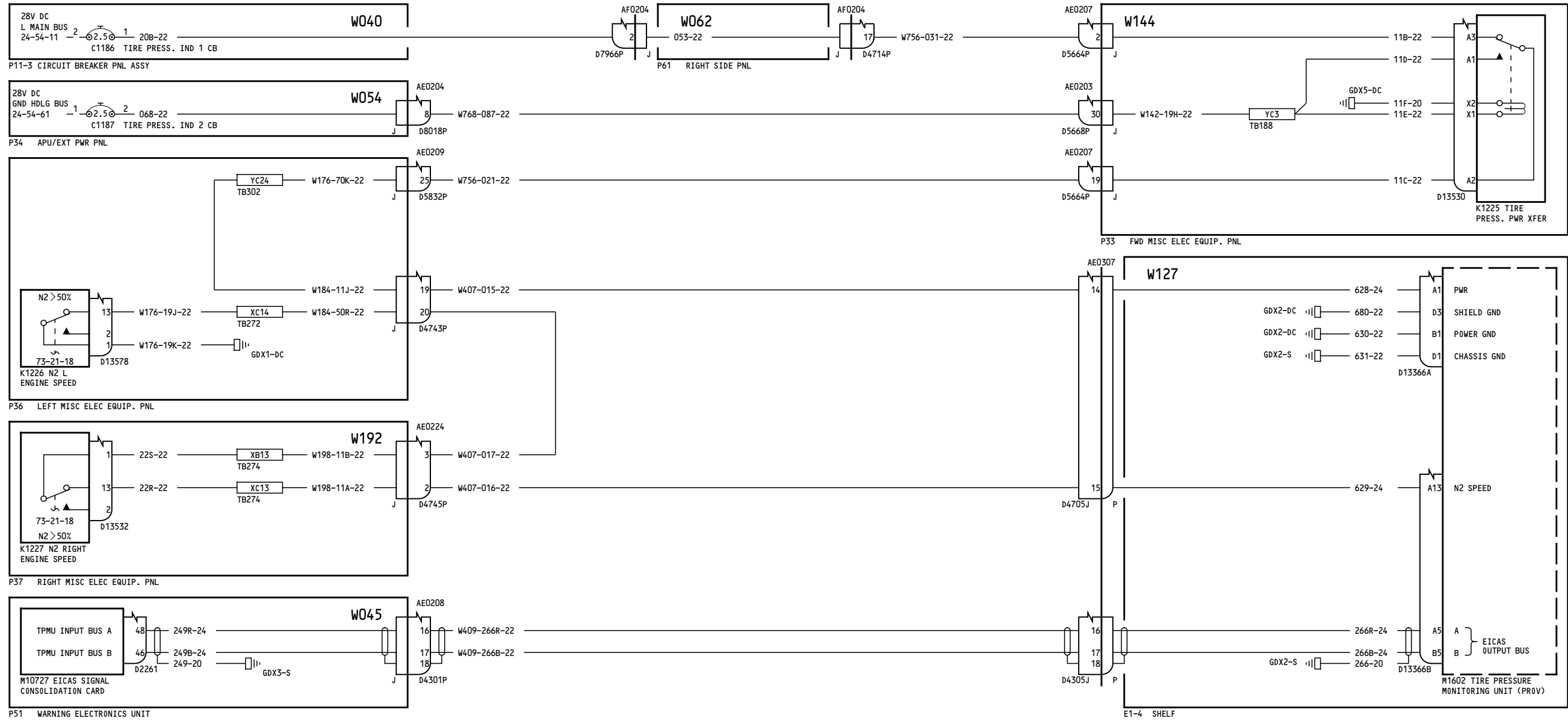

050-099, 155-199

**TIRE PRESSURE INDICATION SYSTEM- POWER & MONITORING**

**32-45-11**

Page 1

Jan 21/2005

D280T132

**32-45-11**

Page 1

Jan 21/2005

20

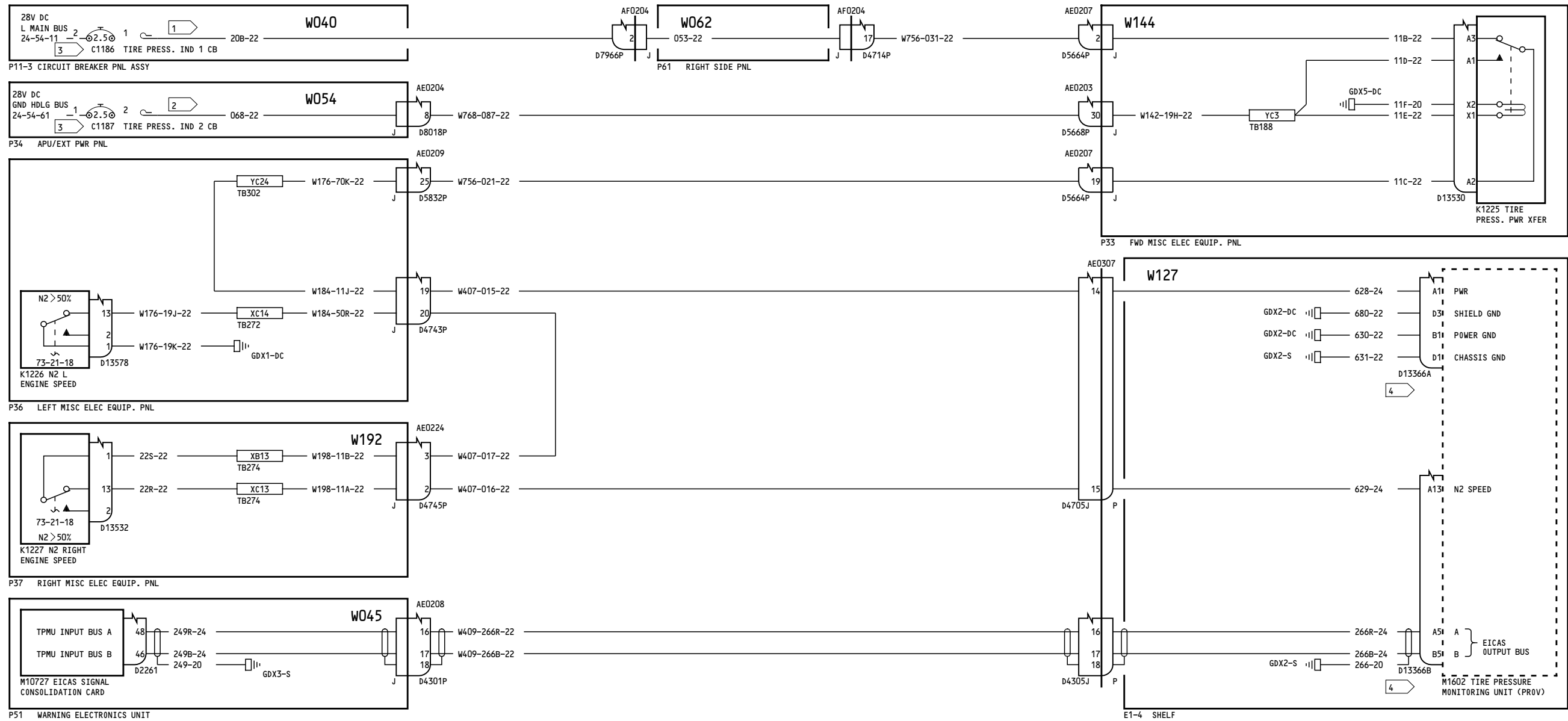

**NOTES:**

- 1 CAP AND STOW NEAR C1186
- 2 CAP AND STOW NEAR C1187
- 3 COLLAR AND LABEL INOP
- 4 CAP & STOW CONNECTOR WHEN MATING EQUIPMENT IS NOT INSTALLED

157-162

**TIRE PRESSURE INDICATION SYSTEM- POWER & MONITORING**

**32-45-11**

Page 1.1

Mar 14/2007

D280T132

Incorporates  
32-0214

**32-45-11**

Page 1.1

Mar 14/2007

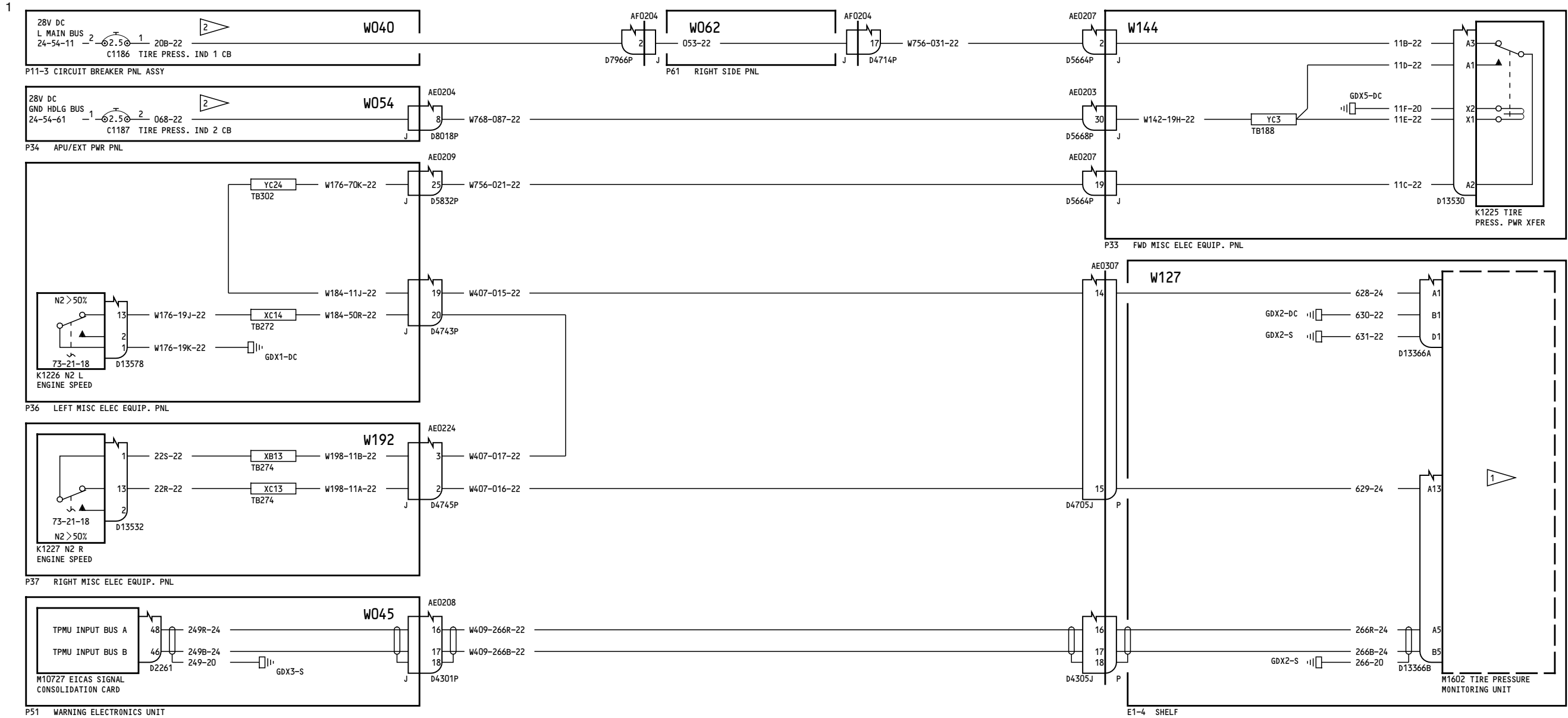

NOTES:  
 1 EQUIPMENT NOT INSTALLED (PROVISIONS ONLY)  
 2 COLLARED

150-154

**TIRE PRESSURE INDICATION  
 SYSTEM-  
 POWER & MONITORING**

D280T132

**32-45-11**

Page 2

Jan 21/2005

**32-45-11**

Page 2

Jan 21/2005

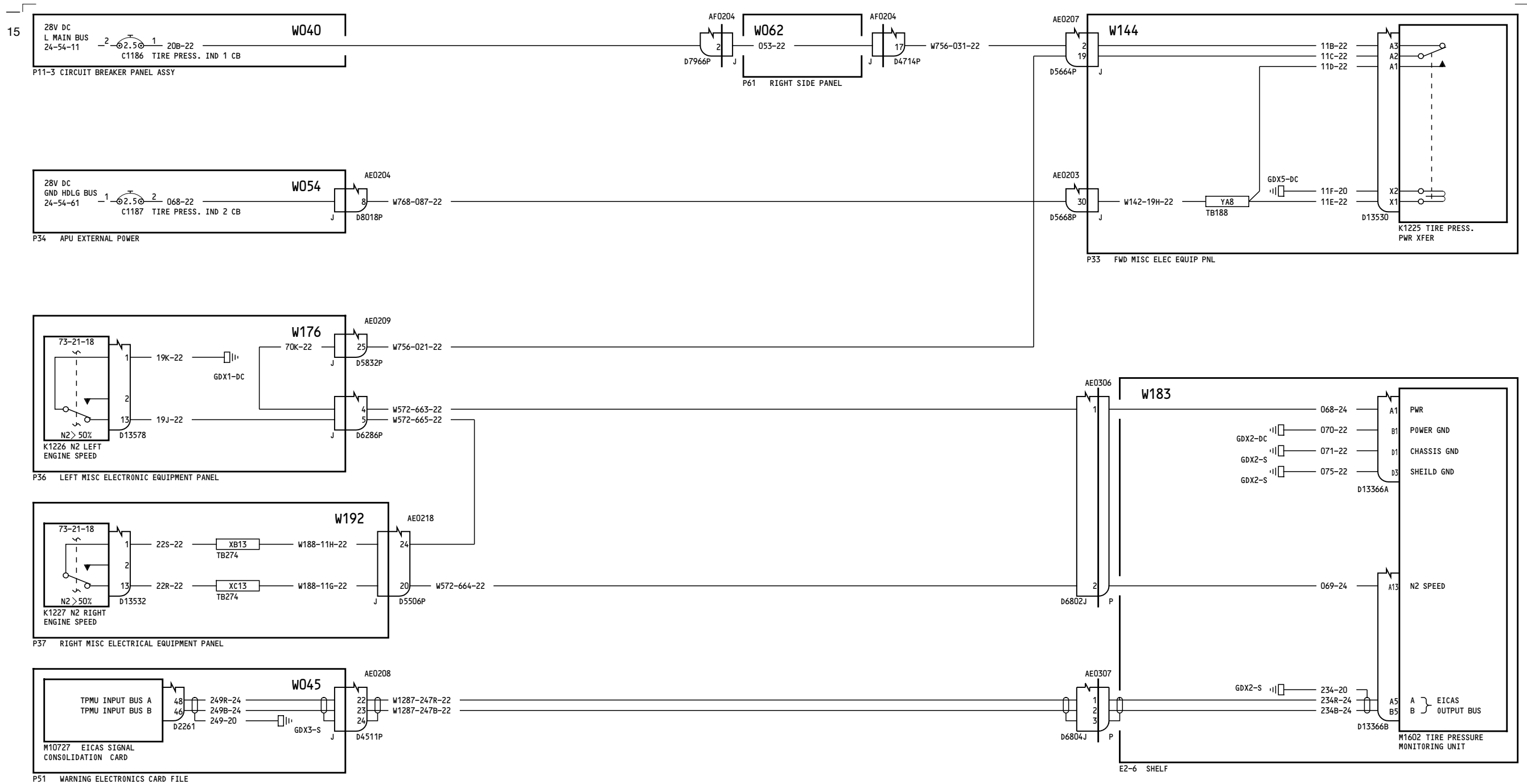

275-276

**TIRE PRESSURE INDICATION  
SYSTEM-  
POWER & MONITORING**

**32-45-11**

Page 3.1

D280T132

Jan 21/2005

Incorporates  
32-0085

**32-45-11**

Page 3.1

Jan 21/2005

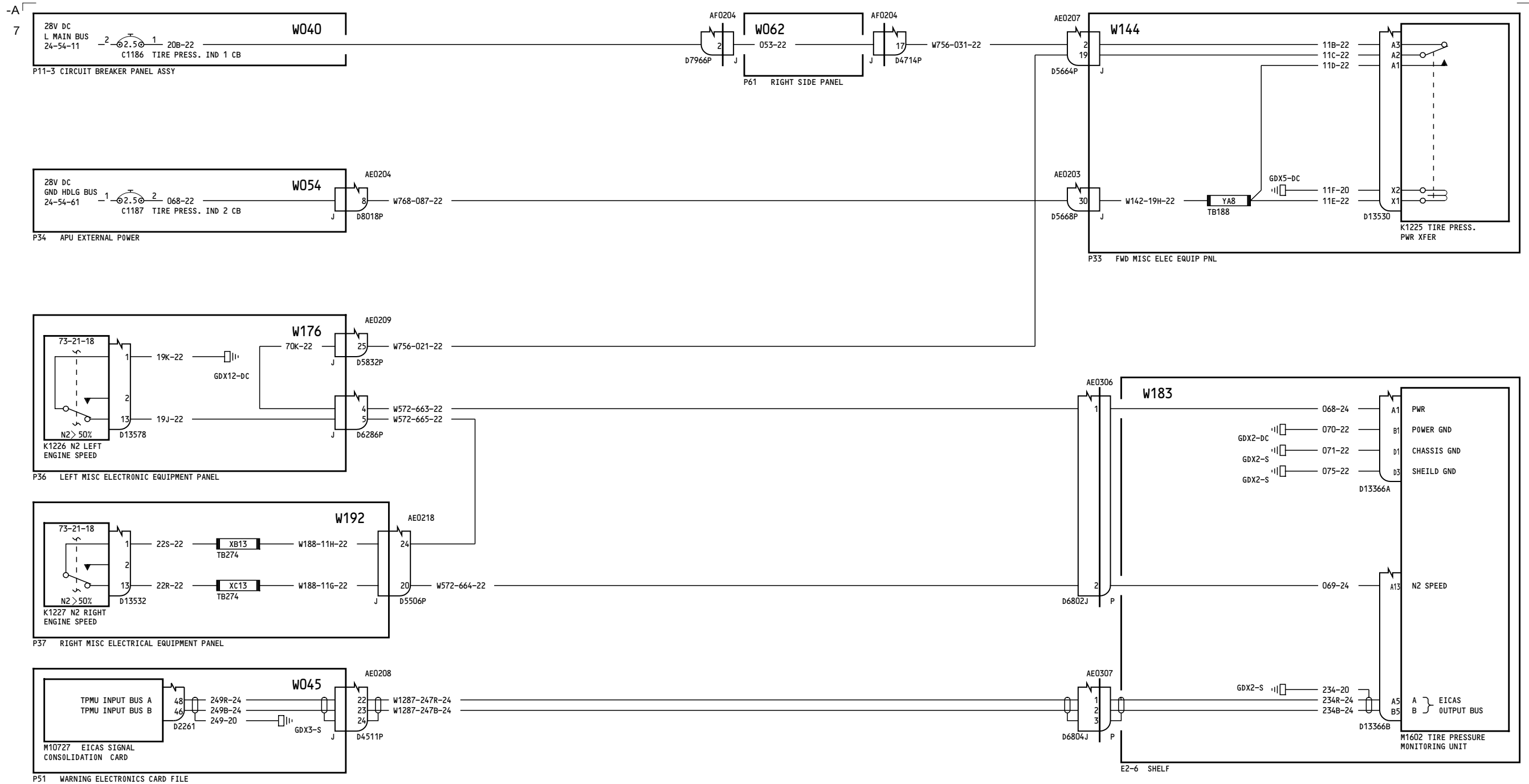

277-278

**TIRE PRESSURE INDICATION SYSTEM- POWER & MONITORING**

**32-45-11**

Page 4

D280T132

Jan 21/2005

**32-45-11**

Page 4

Jan 21/2005

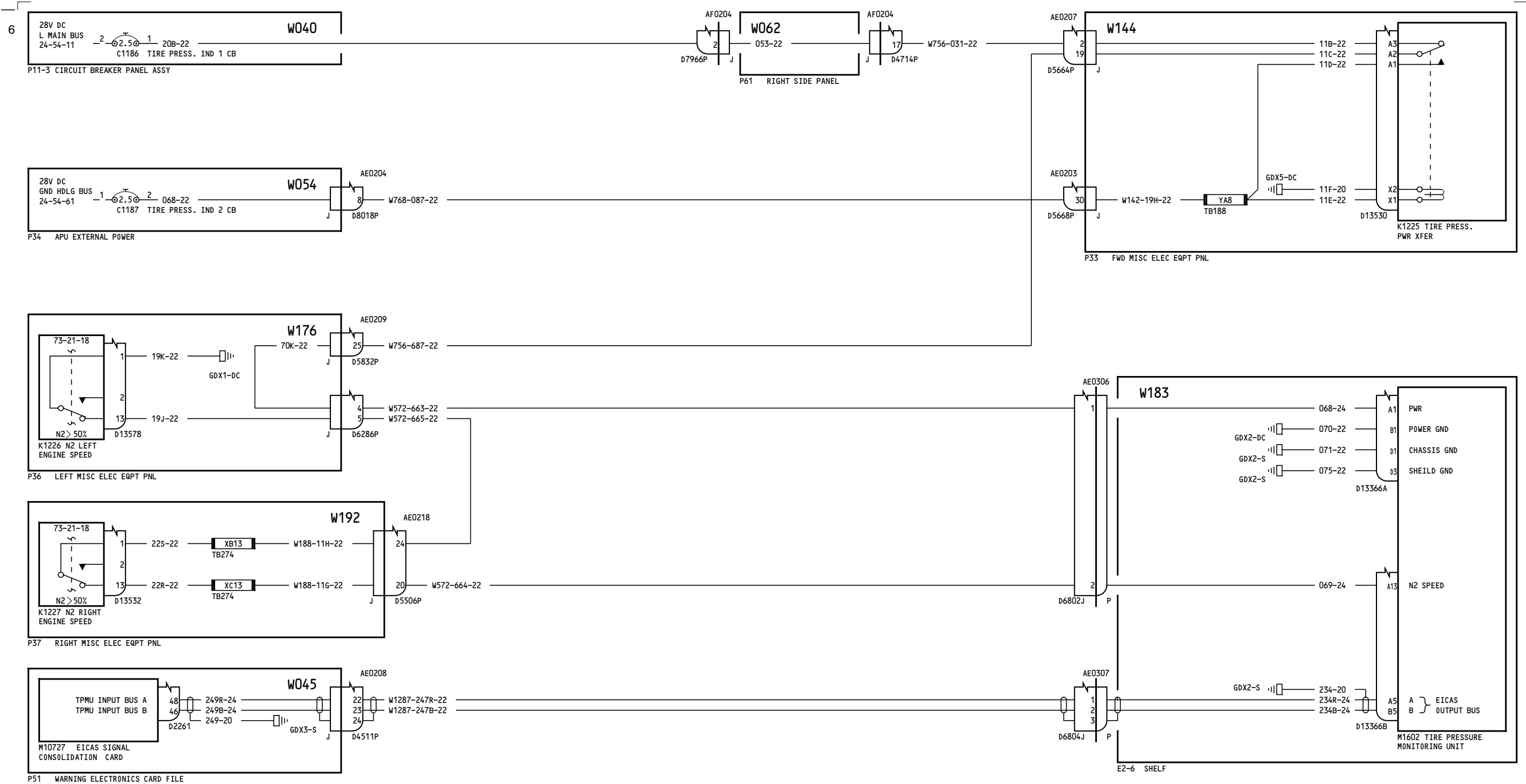

280-299

**TIRE PRESSURE INDICATION SYSTEM- POWER & MONITORING**

**32-45-11**

Page 5

D280T132

Jan 21/2005

**32-45-11**

Page 5

Jan 21/2005

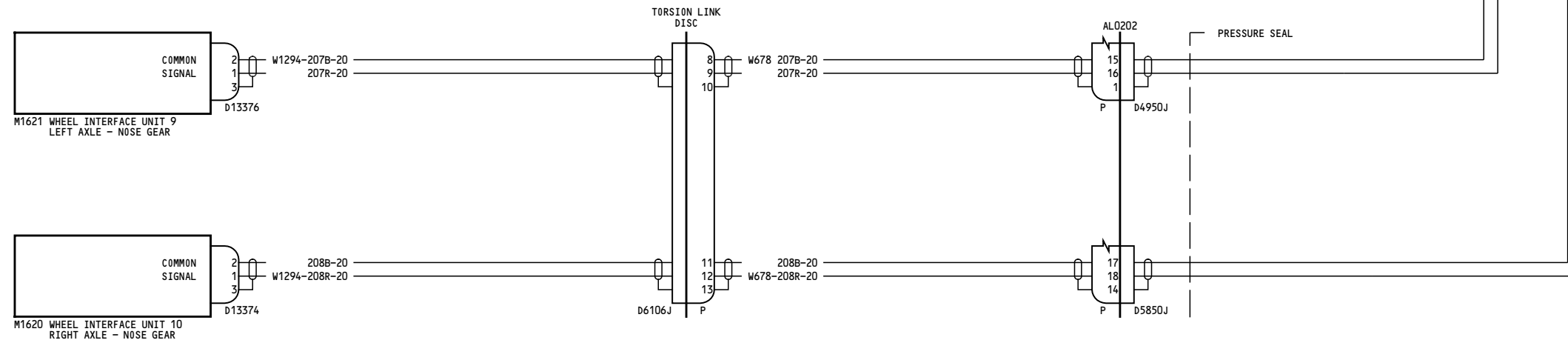
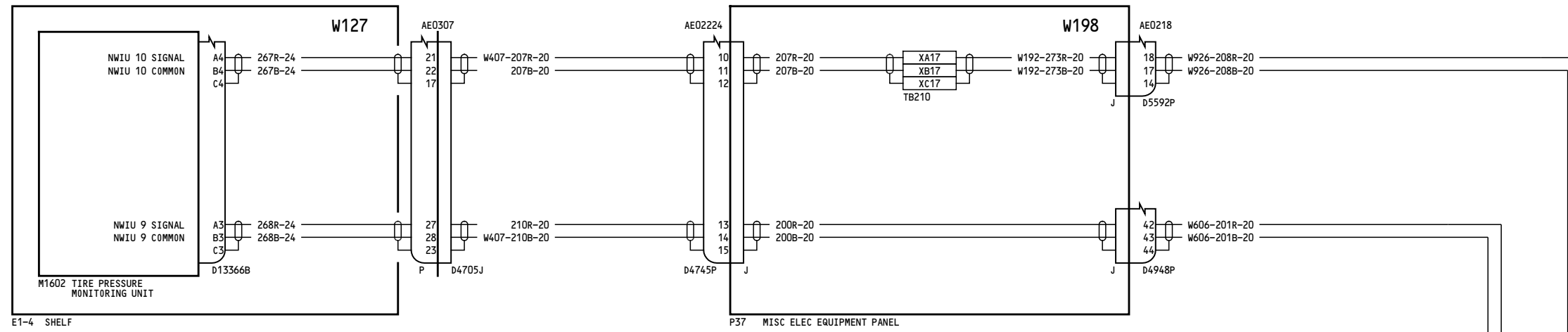

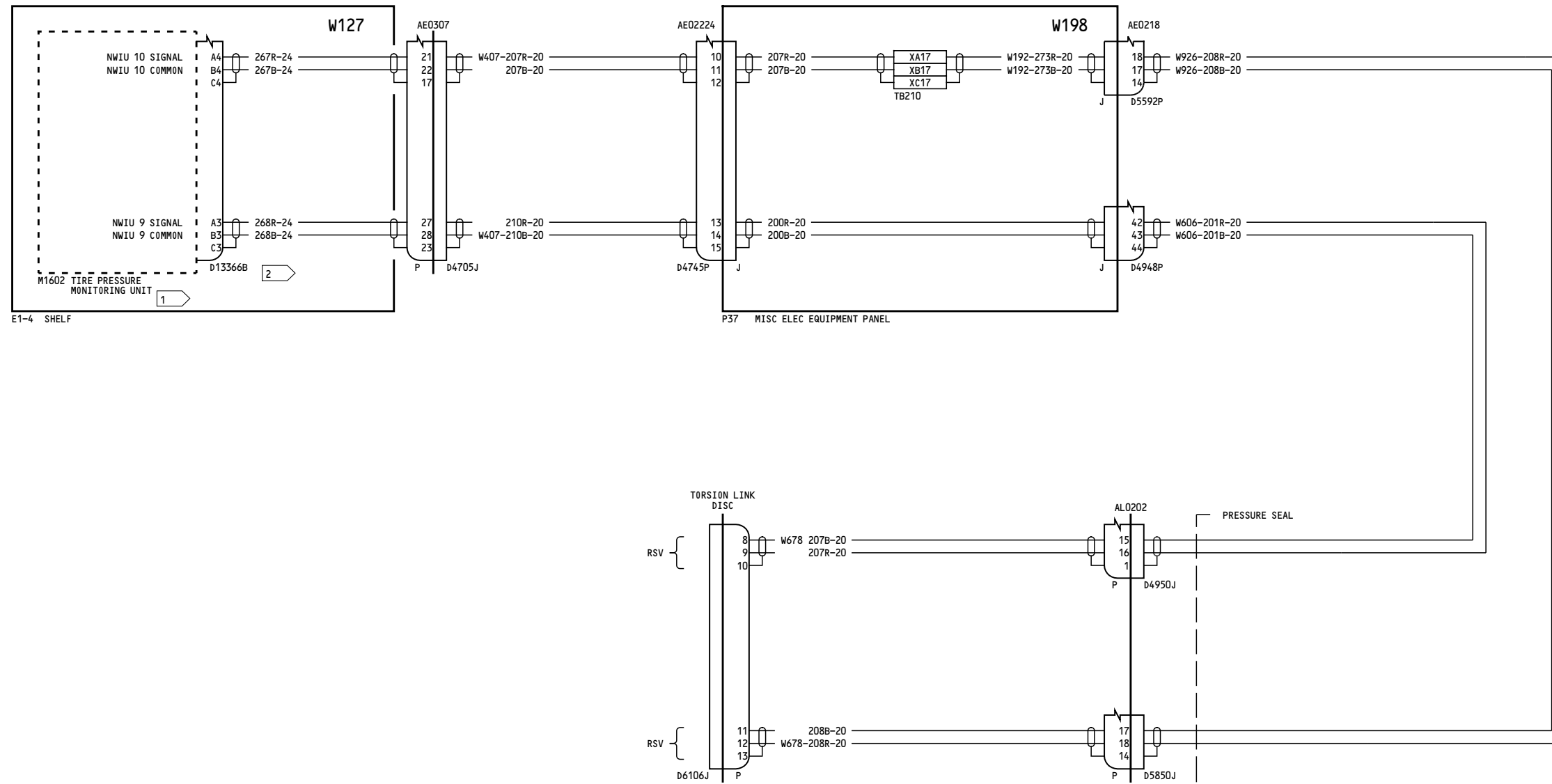

**NOTES:**

1 EQUIPMENT NOT INSTALLED

2 CONNECTOR CAP AND STOWED

157-162

**TIRE PRESSURE INDICATION SYSTEM- NOSE GEAR SENSORS**

D280T132

**32-45-12**

Page 1.1

Mar 14/2007

Incorporates  
32-0214

**32-45-12**

Page 1.1

Mar 14/2007



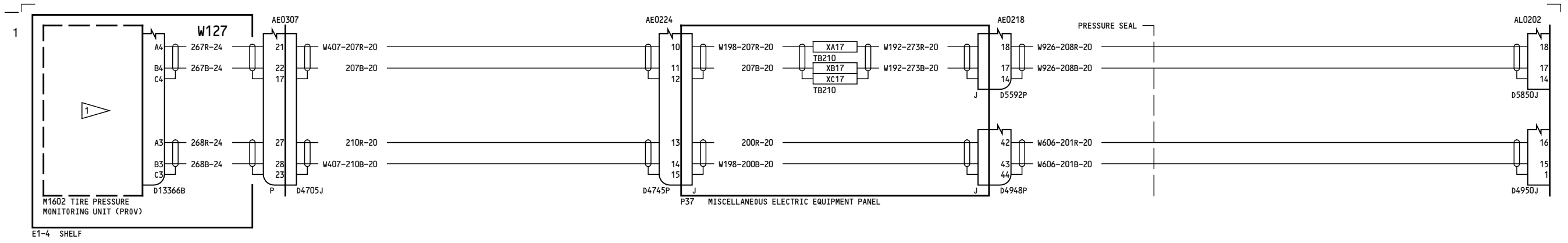

NOTES:  
 1 EQUIPMENT NOT INSTALLED (PROVISIONS ONLY)

150-154

**TIRE PRESSURE INDICATION  
 SYSTEM-  
 NOSE GEAR SENSORS**

D280T132

**32-45-12**

Page 2

Jan 21/2005

**32-45-12**

Page 2

Jan 21/2005

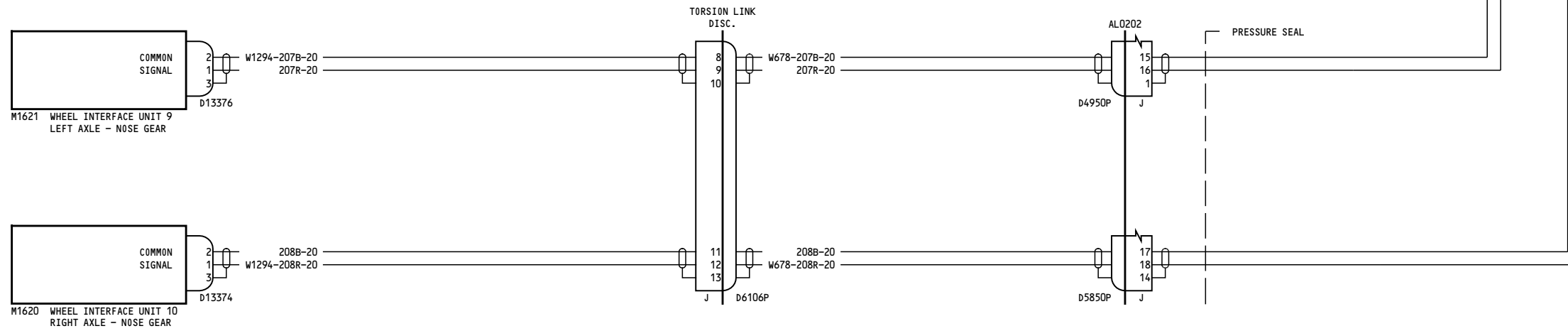
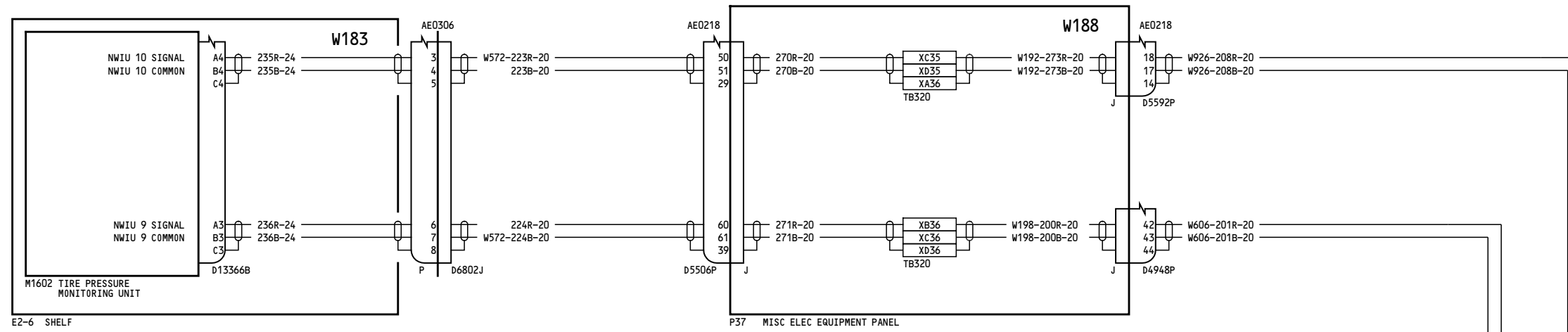

275-276

**TIRE PRESSURE INDICATION SYSTEM- NOSE GEAR SENSORS**

D280T132

**32-45-12**

Page 3.1

Jan 21/2005

Incorporates  
 32-0085

**32-45-12**

Page 3.1

Jan 21/2005

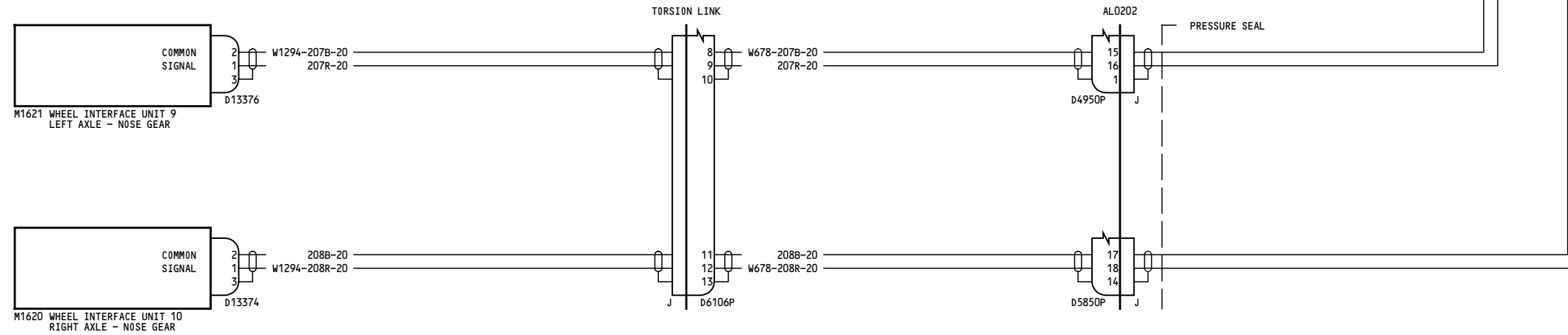
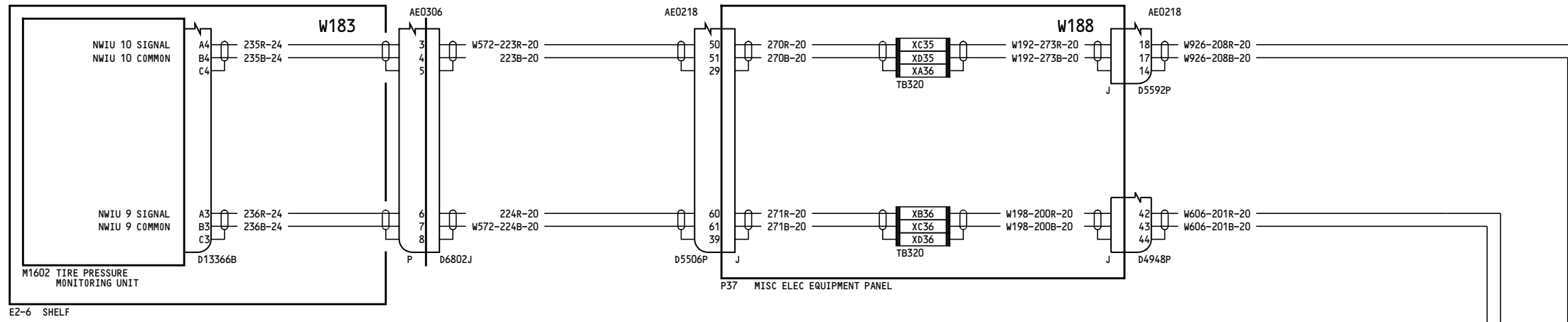

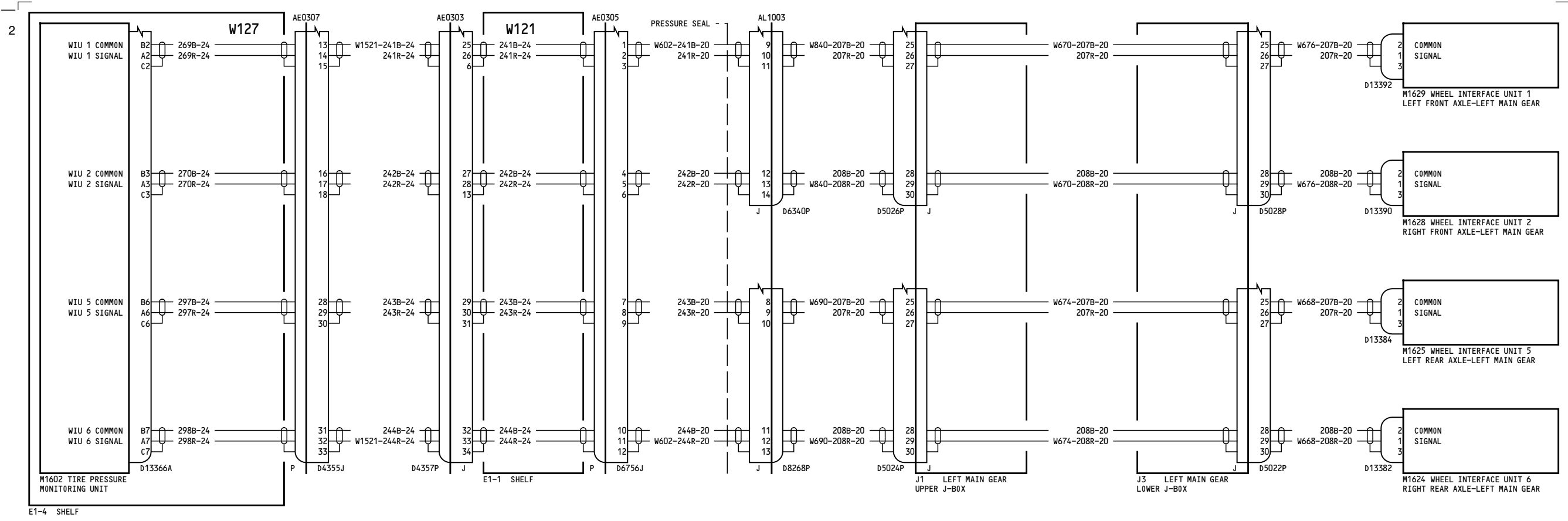

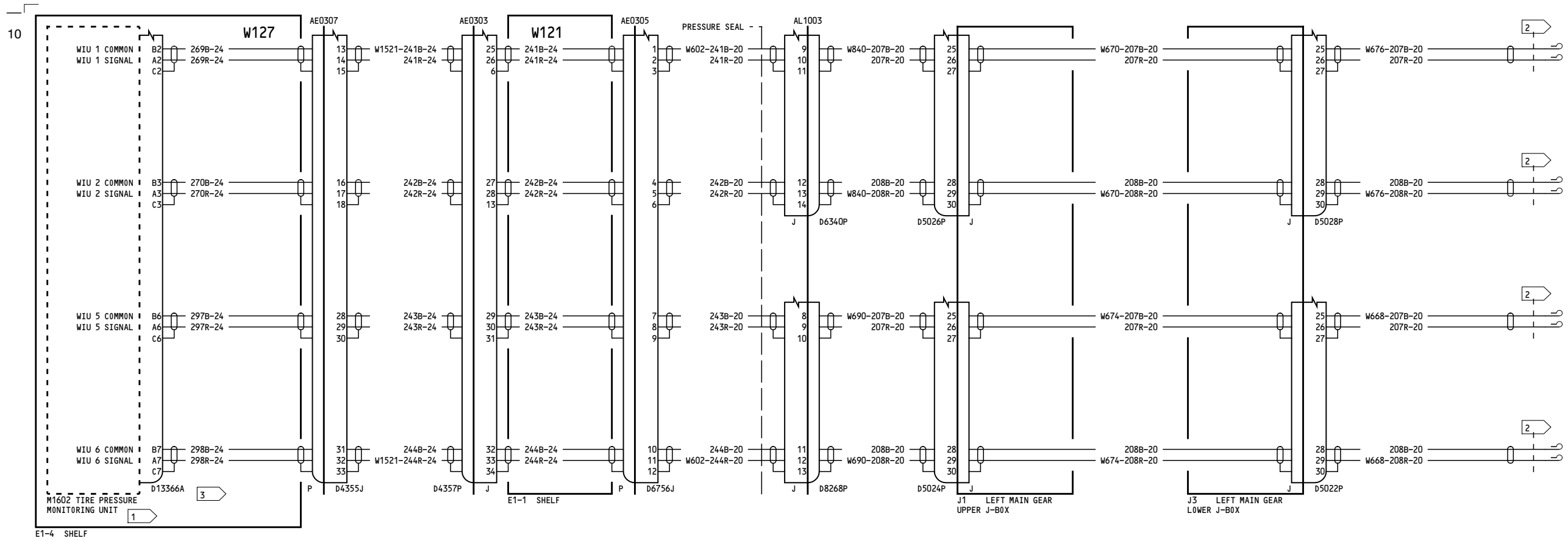

**NOTES:**

- 1 EQUIPMENT NOT INSTALLED
- 2 CAP AND STOWED IN AXLE
- 3 CONNECTOR CAP AND STOWED

157-162

**TIRE PRESSURE INDICATION  
SYSTEM-LEFT MAIN GEAR  
SENSORS**

D280T132

**32-45-13**

Page 1.1

Mar 14/2007

Incorporates  
▶ 32-0214

**32-45-13**

Page 1.1

Mar 14/2007

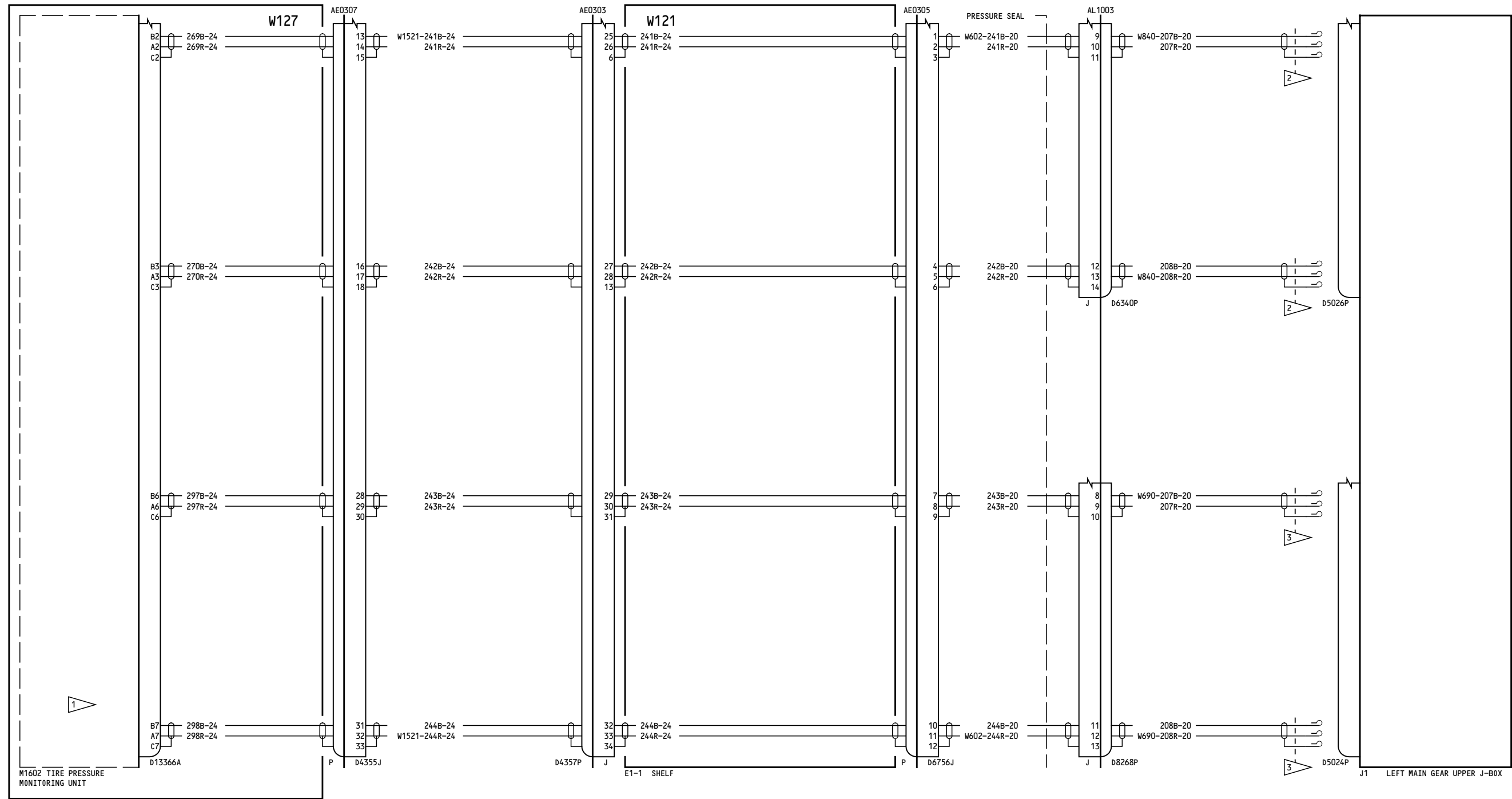

- NOTES:
- 1 EQUIPMENT NOT INSTALLED (PROVISIONS ONLY)
  - 2 CAP & STOW NEAR D5026P
  - 3 CAP & STOW NEAR D5024P

150-154

**TIRE PRESSURE INDICATION SYSTEM-LEFT MAIN GEAR SENSORS**

D280T132

**32-45-13**

Page 2

Jan 21/2005

**32-45-13**

Page 2

Jan 21/2005

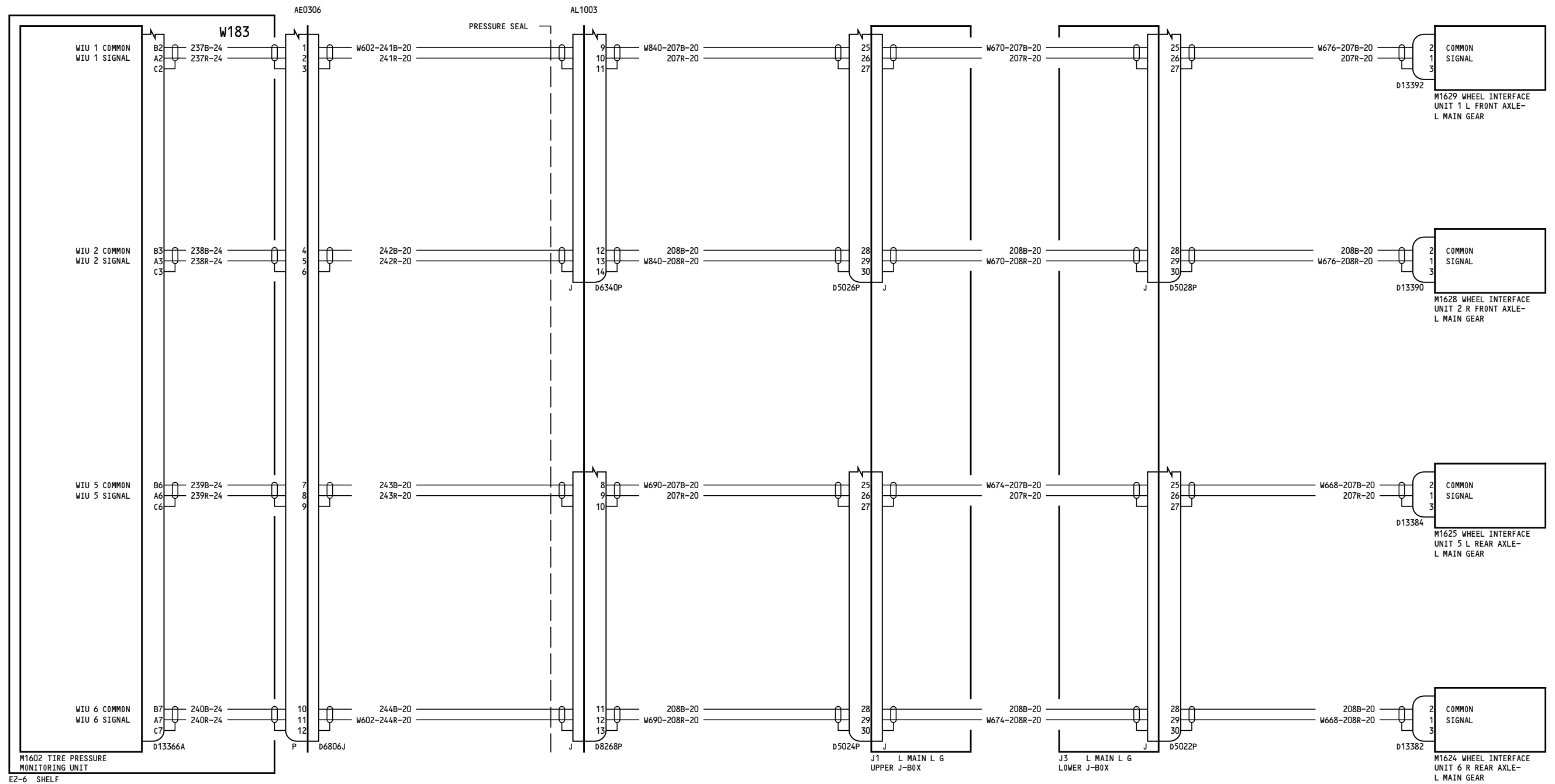

275-276	<p align="center"><b>TIRE PRESSURE INDICATION SYSTEM-LEFT MAIN GEAR SENSORS</b></p> <p align="center">D280T132</p>
---------	--

**32-45-13**

Page 3.1

Jan 21/2005

Incorporates  
 32-0085

**32-45-13**

Page 3.1

Jan 21/2005

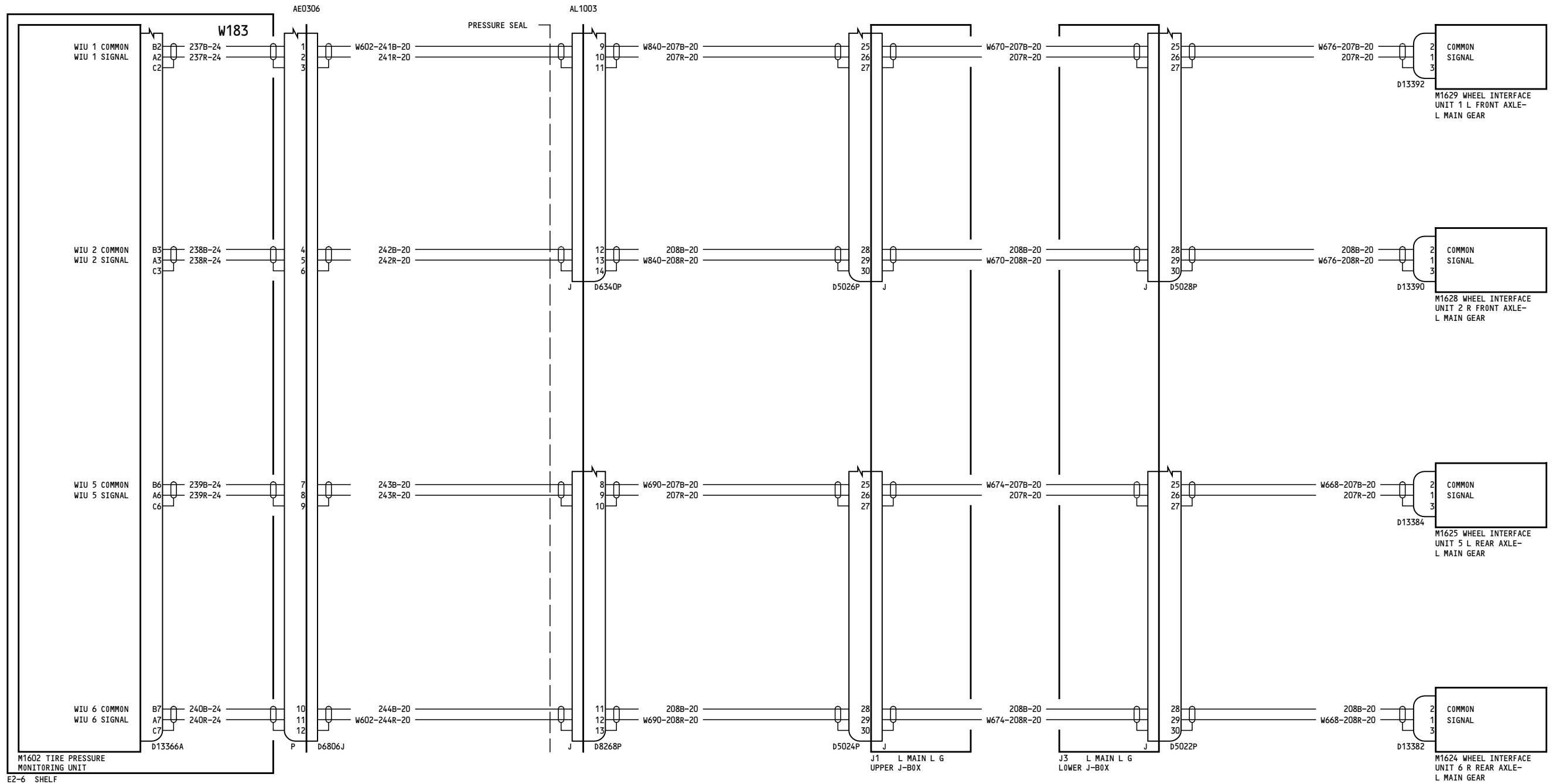

277-299

**TIRE PRESSURE INDICATION SYSTEM-LEFT MAIN GEAR SENSORS**

**32-45-13**

Page 4

D280T132

Jan 21/2005

**32-45-13**

Page 4

Jan 21/2005



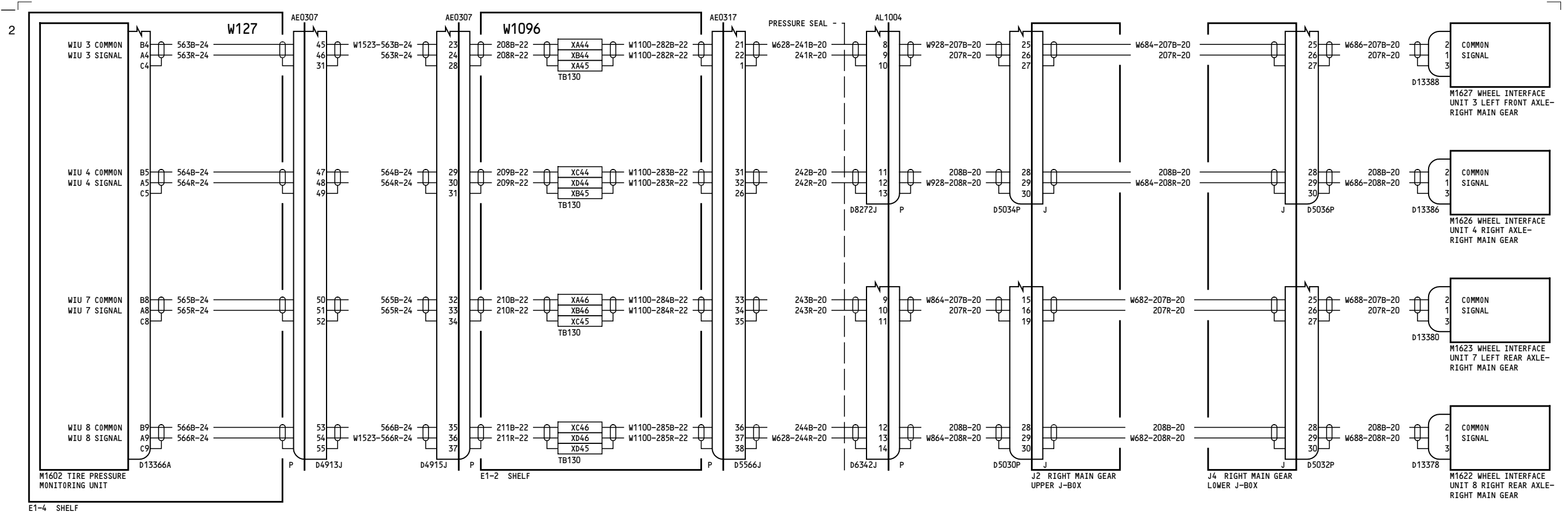

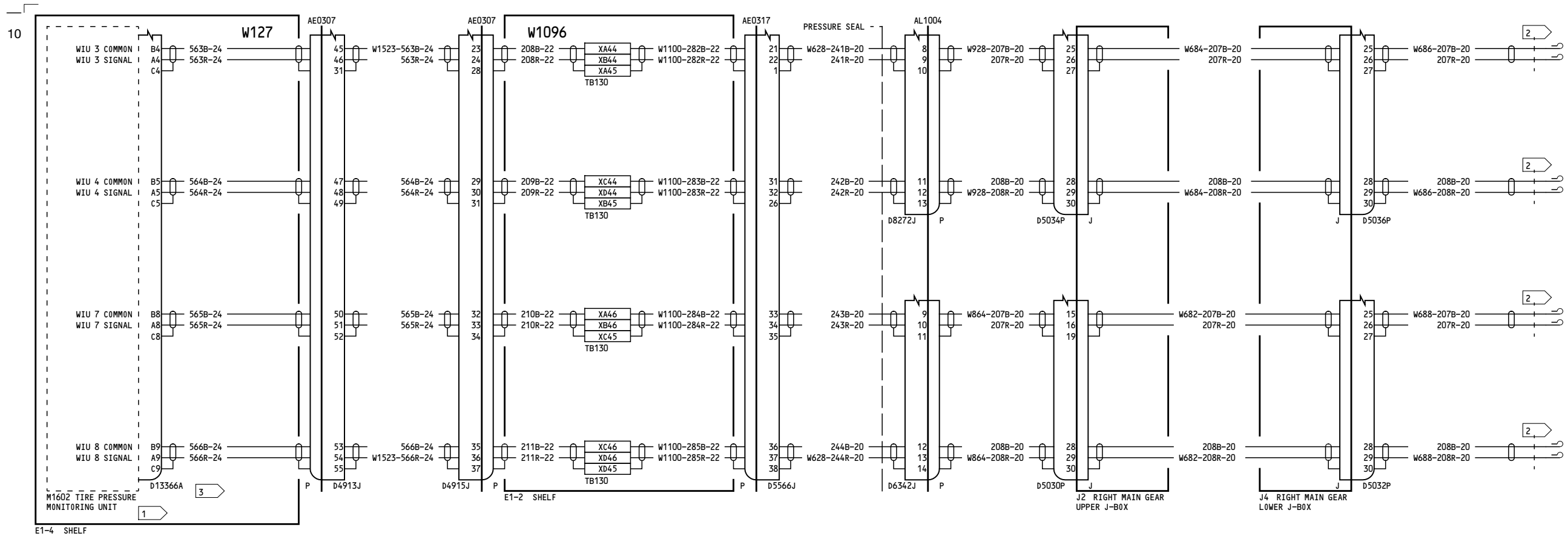

- NOTES:
- 1 EQUIPMENT NOT INSTALLED
  - 2 CAP AND STOWED IN AXLE
  - 3 CONNECTOR CAP AND STOWED

157-162

**TIRE PRESSURE INDICATION  
SYSTEM-RIGHT MAIN GEAR  
SENSORS**

D280T132

**32-45-14**

Page 1.1

Mar 14/2007

Incorporates  
32-0214

**32-45-14**

Page 1.1

Mar 14/2007

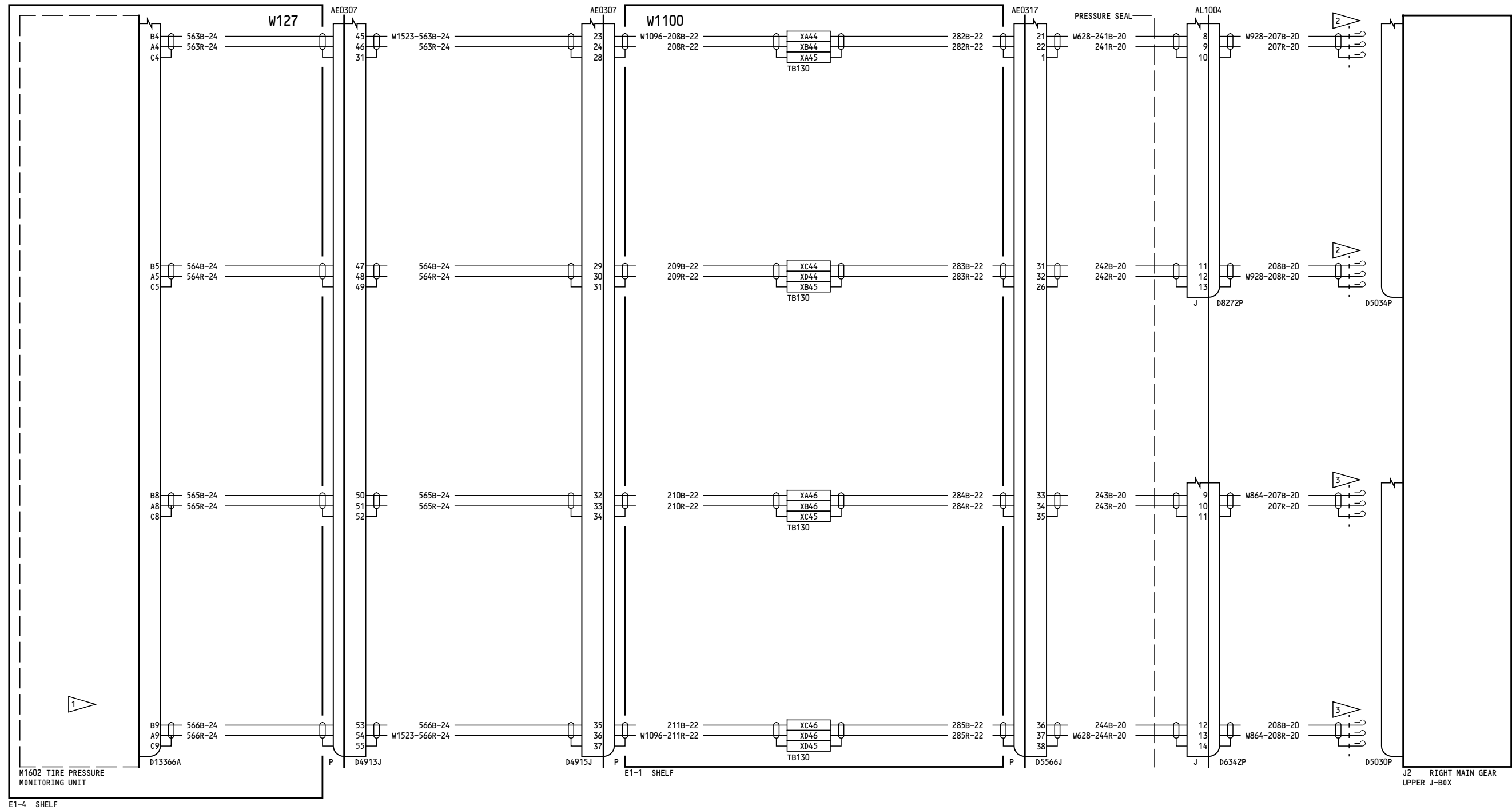

NOTES:  
 1 EQUIPMENT NOT INSTALLED (PROVISIONS ONLY)    2 CAP & STOW NEAR D5034P    3 CAP & STOW NEAR D5030P

150-154

**TIRE PRESSURE INDICATION SYSTEM-RIGHT MAIN GEAR SENSORS**

D280T132

**32-45-14**

Page 2

Jan 21/2005

**32-45-14**

Page 2

Jan 21/2005

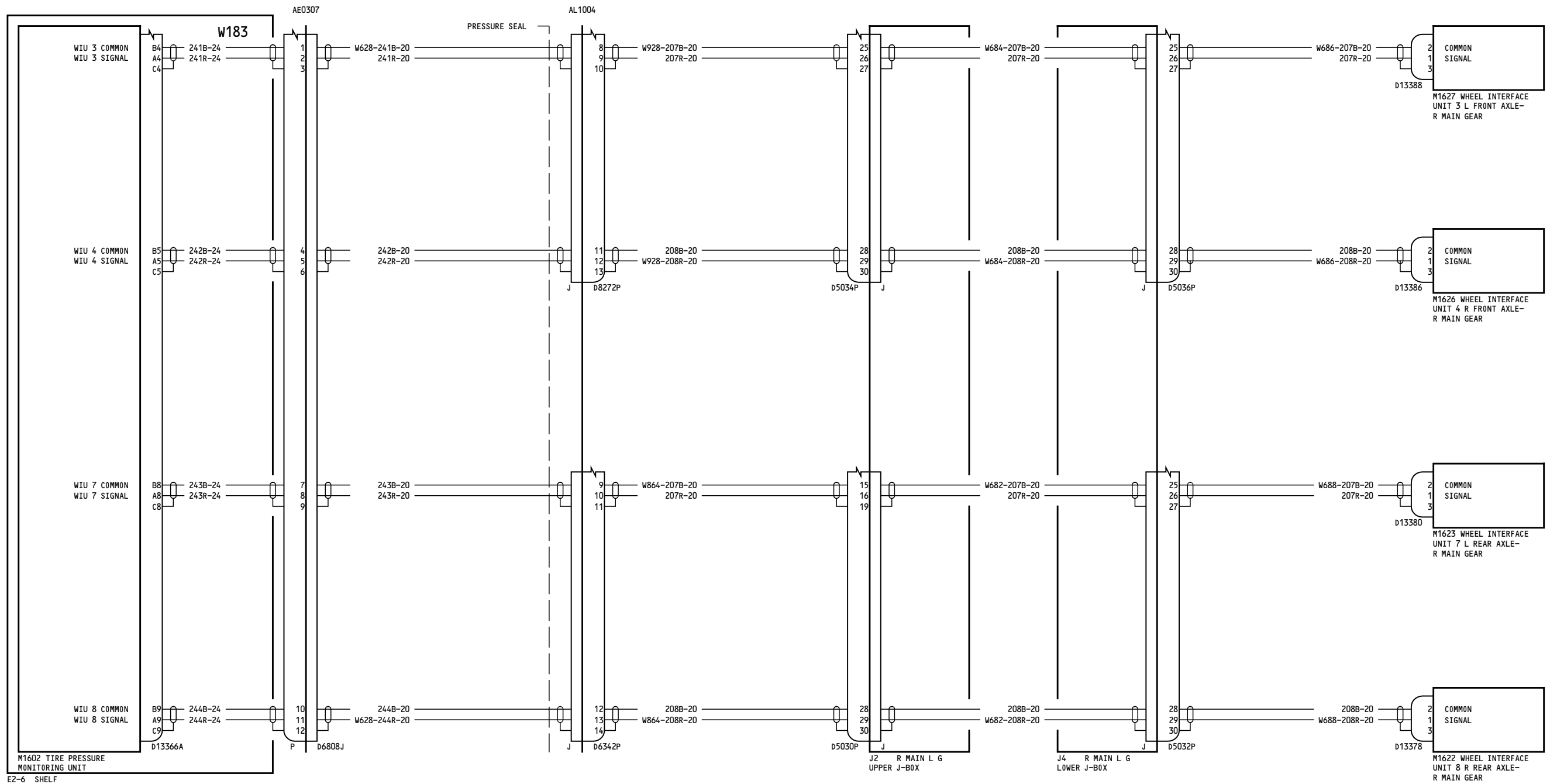

275-276

**TIRE PRESSURE INDICATION  
SYSTEM-RIGHT MAIN GEAR  
SENSORS**

D280T132

**32-45-14**

Page 3.1

Jan 21/2005

Incorporates  
32-0085

**32-45-14**

Page 3.1

Jan 21/2005

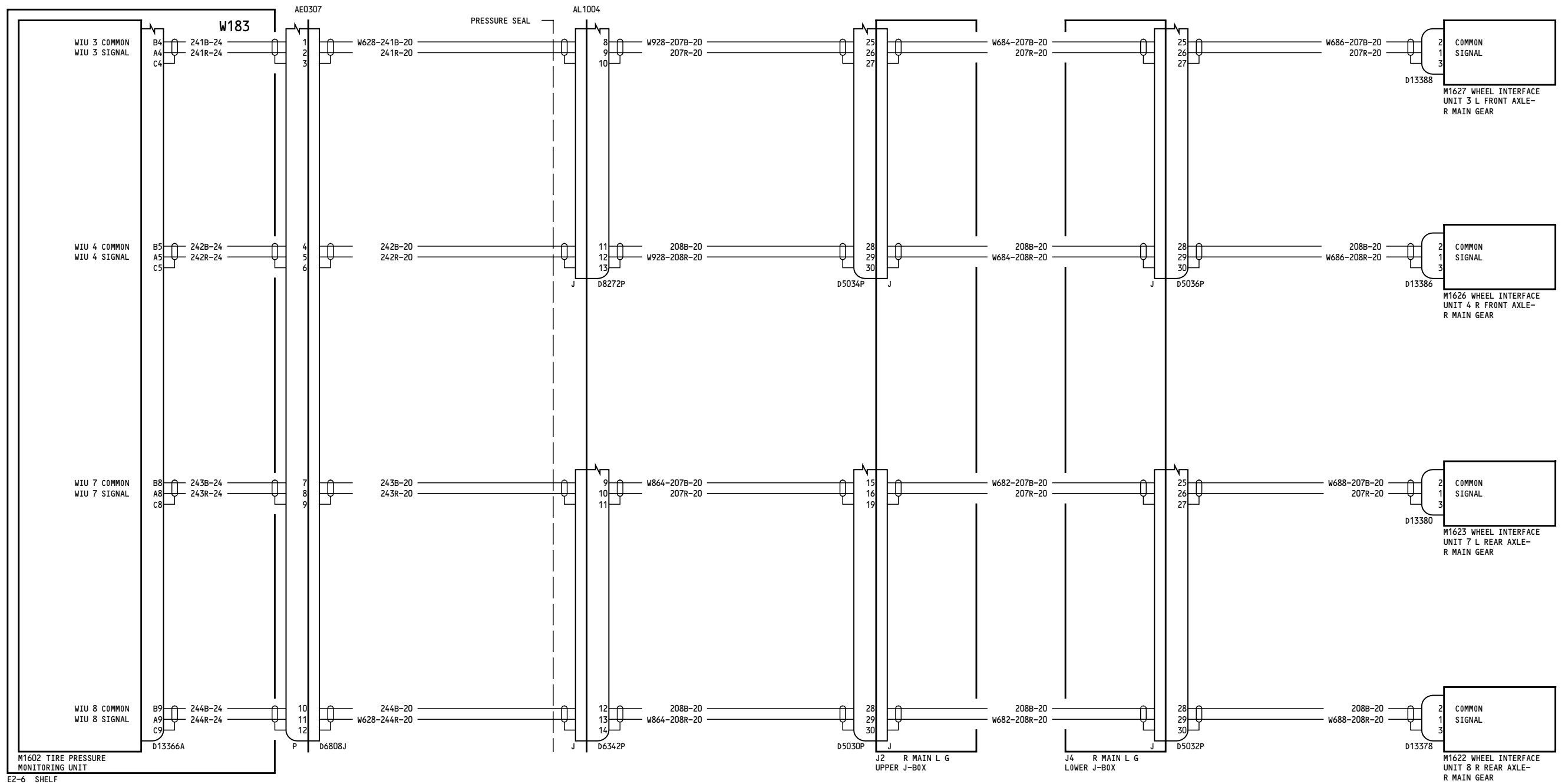

277-299

TIRE PRESSURE INDICATION SYSTEM-RIGHT MAIN GEAR SENSORS

32-45-14

Page 4

D280T132

Jan 21/2005

32-45-14

Page 4

Jan 21/2005

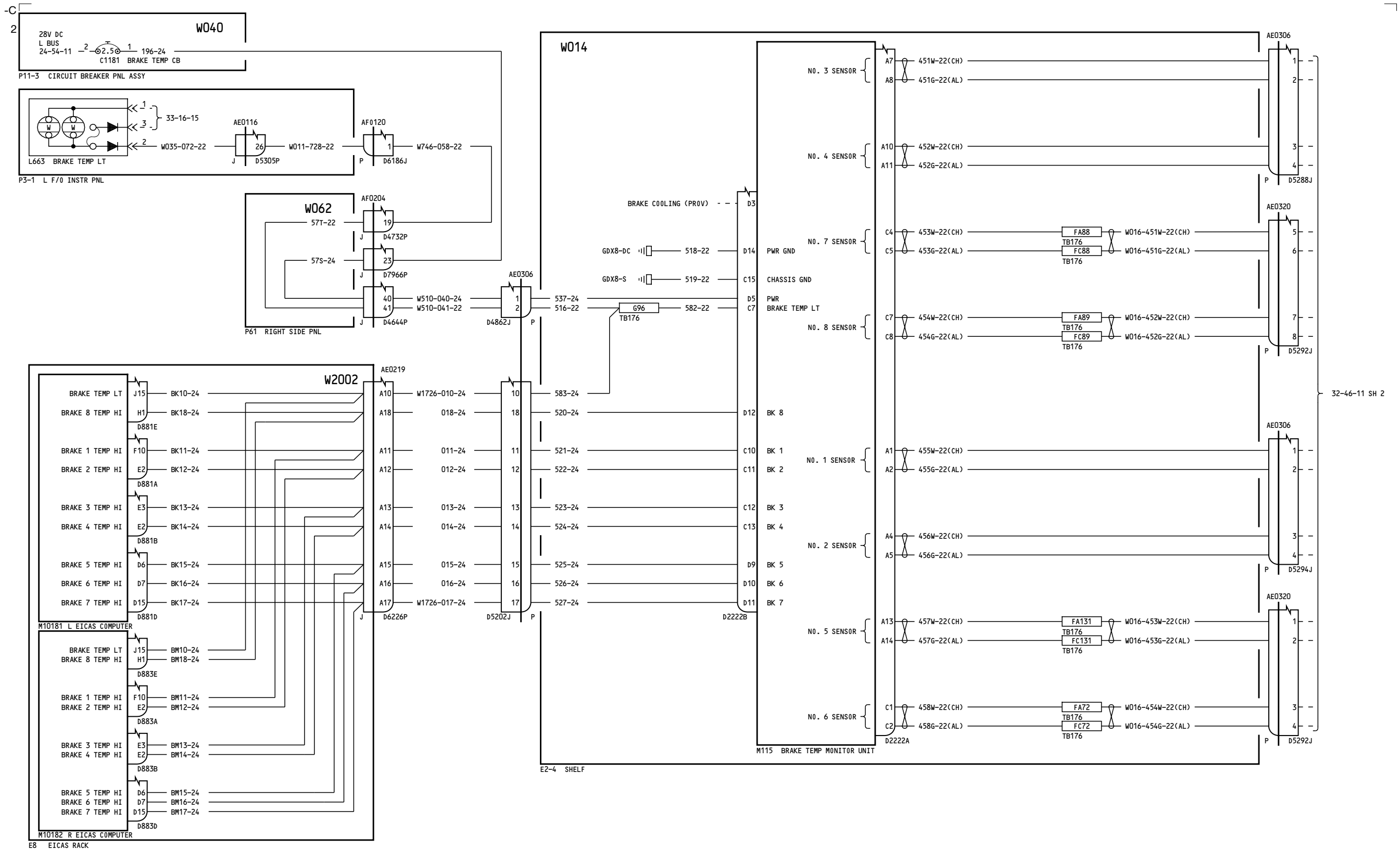

ALL

**BRAKE TEMPERATURE MONITORING SYSTEM**

D280T132

**32-46-11**

Page 1  
Sheet 1  
Jan 21/2005

**32-46-11**

Page 1  
Sheet 1  
Jan 21/2005

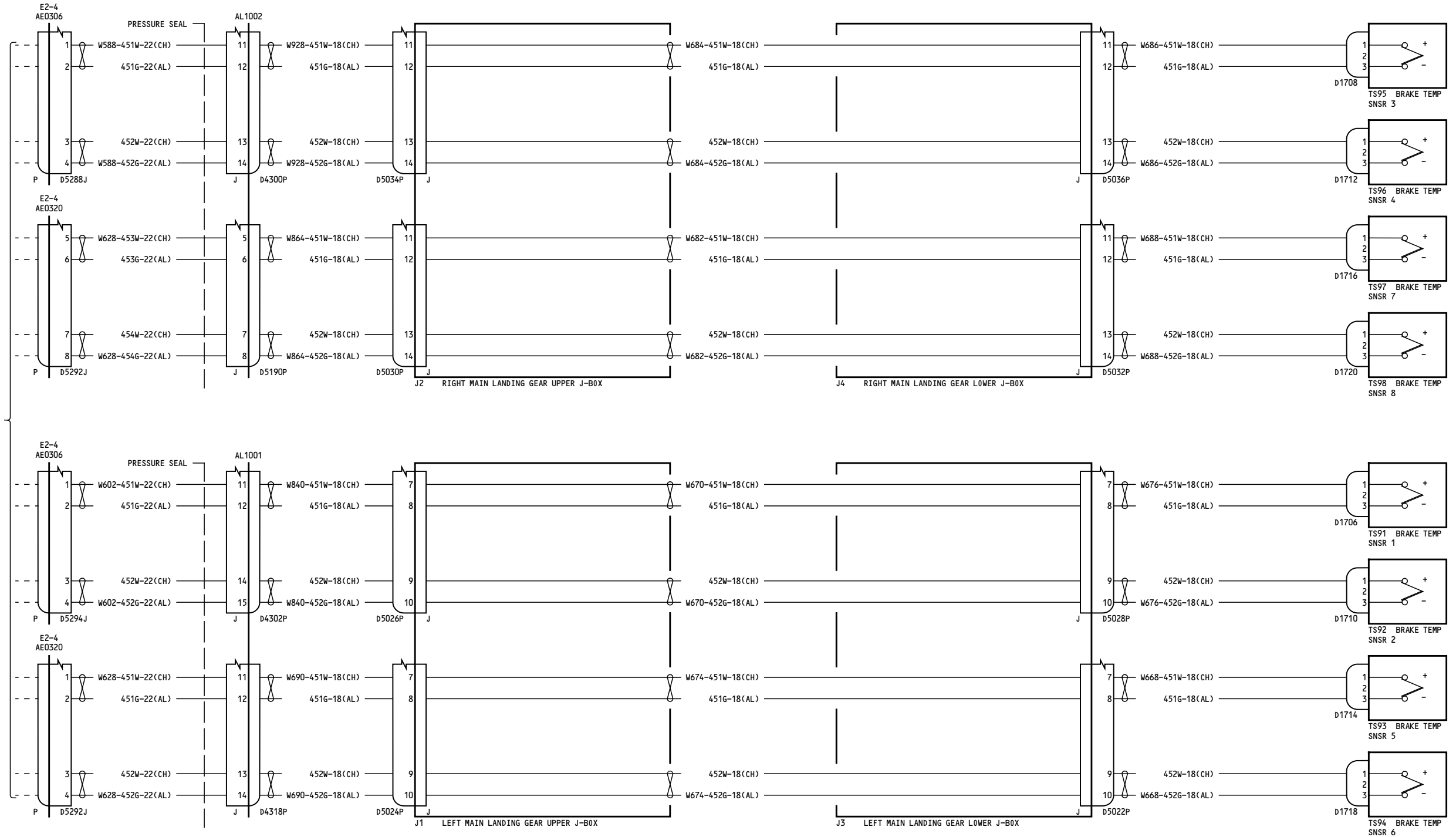

32-46-11 SH 1

ALL	<b>BRAKE TEMPERATURE MONITORING SYSTEM</b>
	D280T132

**32-46-11**

Page 1  
Sheet 2  
Jan 21/2005

**32-46-11**

Page 1  
Sheet 2  
Jan 21/2005

-A  
2

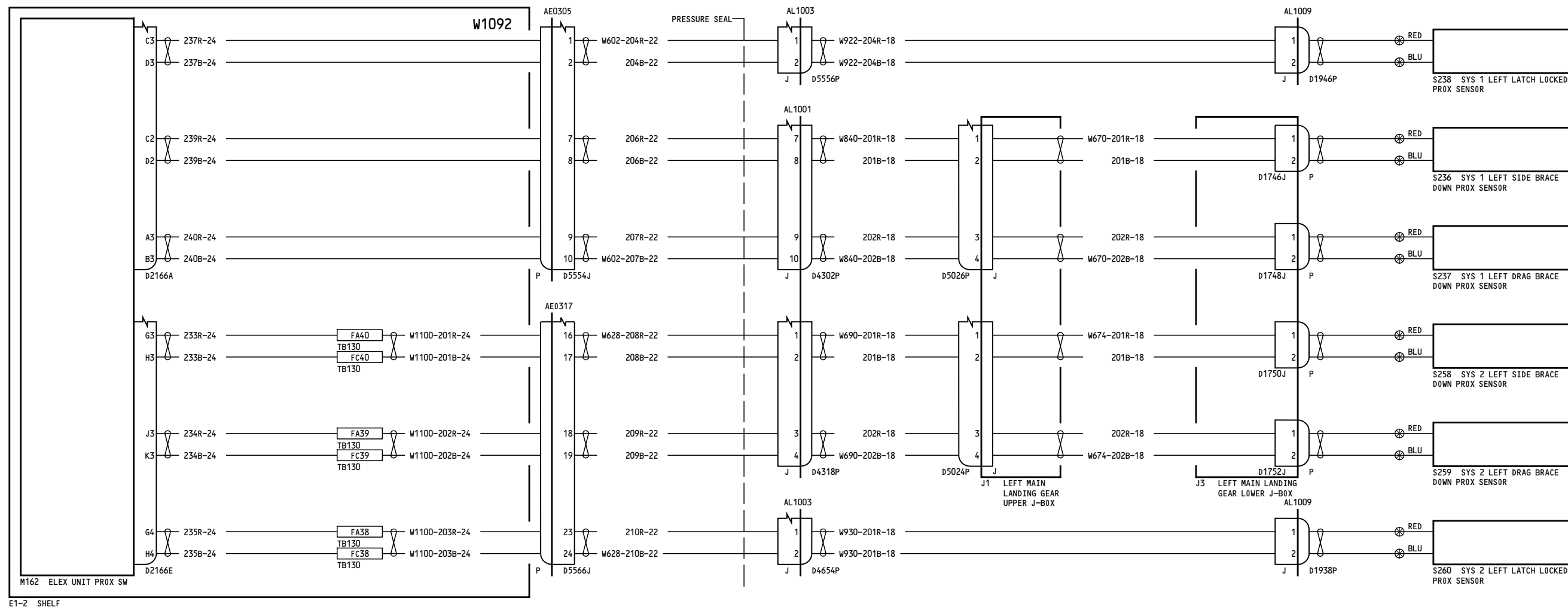

ALL

**LANDING GEAR POSITION  
INDICATION-  
LEFT GEAR**  
  
D280T132

**32-61-11**

Page 1

Jan 21/2005

**32-61-11**

Page 1

Jan 21/2005



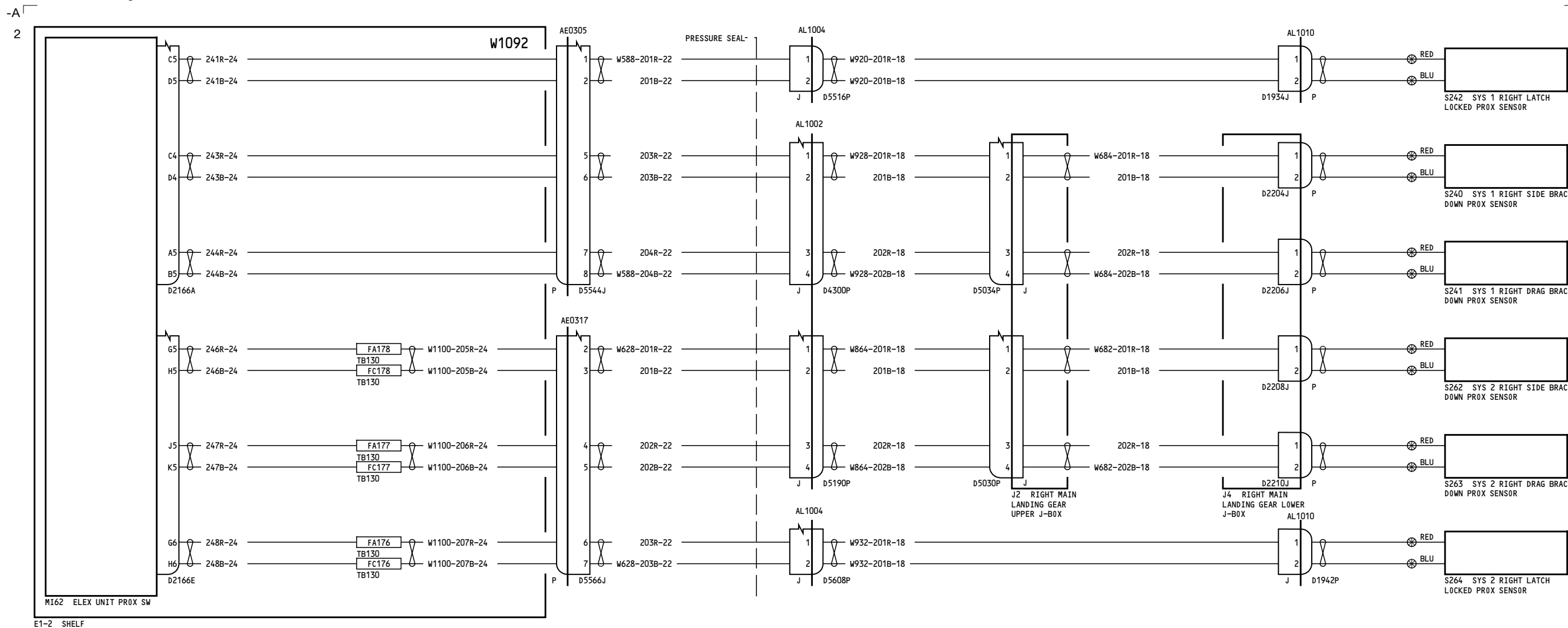

ALL

**LANDING GEAR POSITION INDICATION-RIGHT GEAR**

D280T132

**32-61-12**

Page 1

Jan 21/2005

**32-61-12**

Page 1

Jan 21/2005

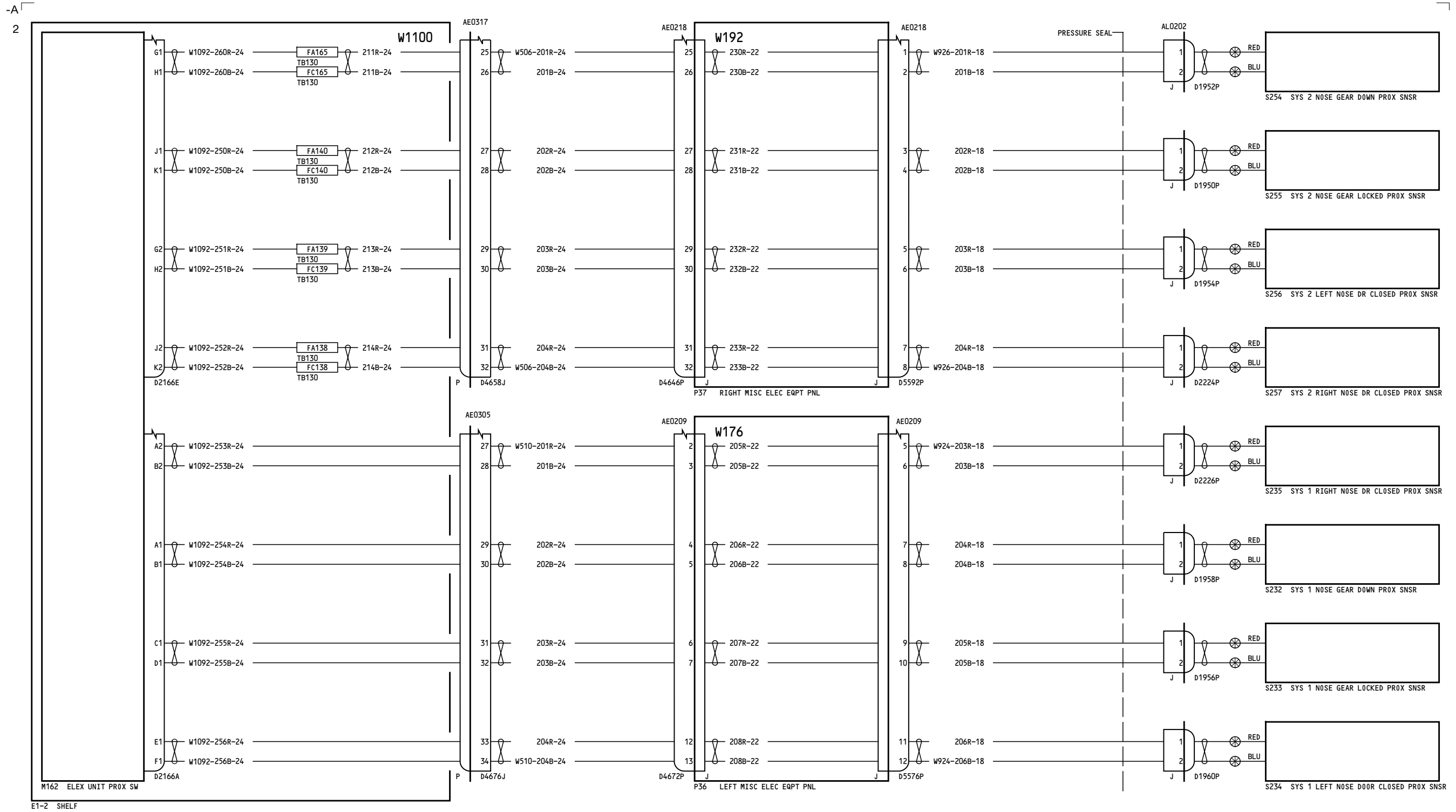

ALL

**LANDING GEAR POSITION INDICATION- NOSE GEAR**

D280T132

**32-61-13**

Page 1

Jan 21/2005

**32-61-13**

Page 1

Jan 21/2005

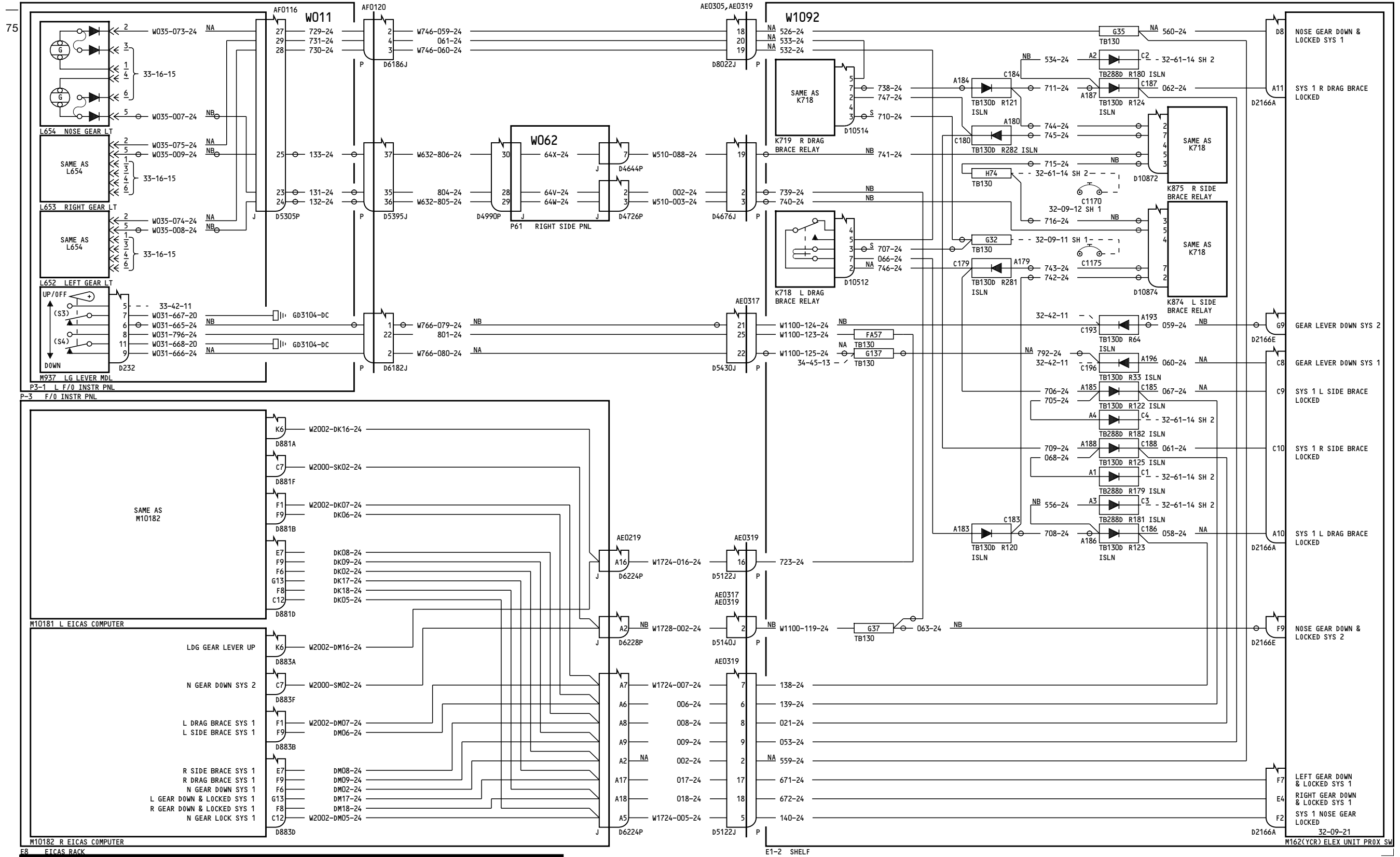

050-051

**LANDING GEAR POSITION INDICATION**

D280T132

**32-61-14**

Page 1A  
Sheet 1  
Jan 21/2005

Incorporates  
MTO 340652

**32-61-14**

Page 1A  
Sheet 1  
Jan 21/2005

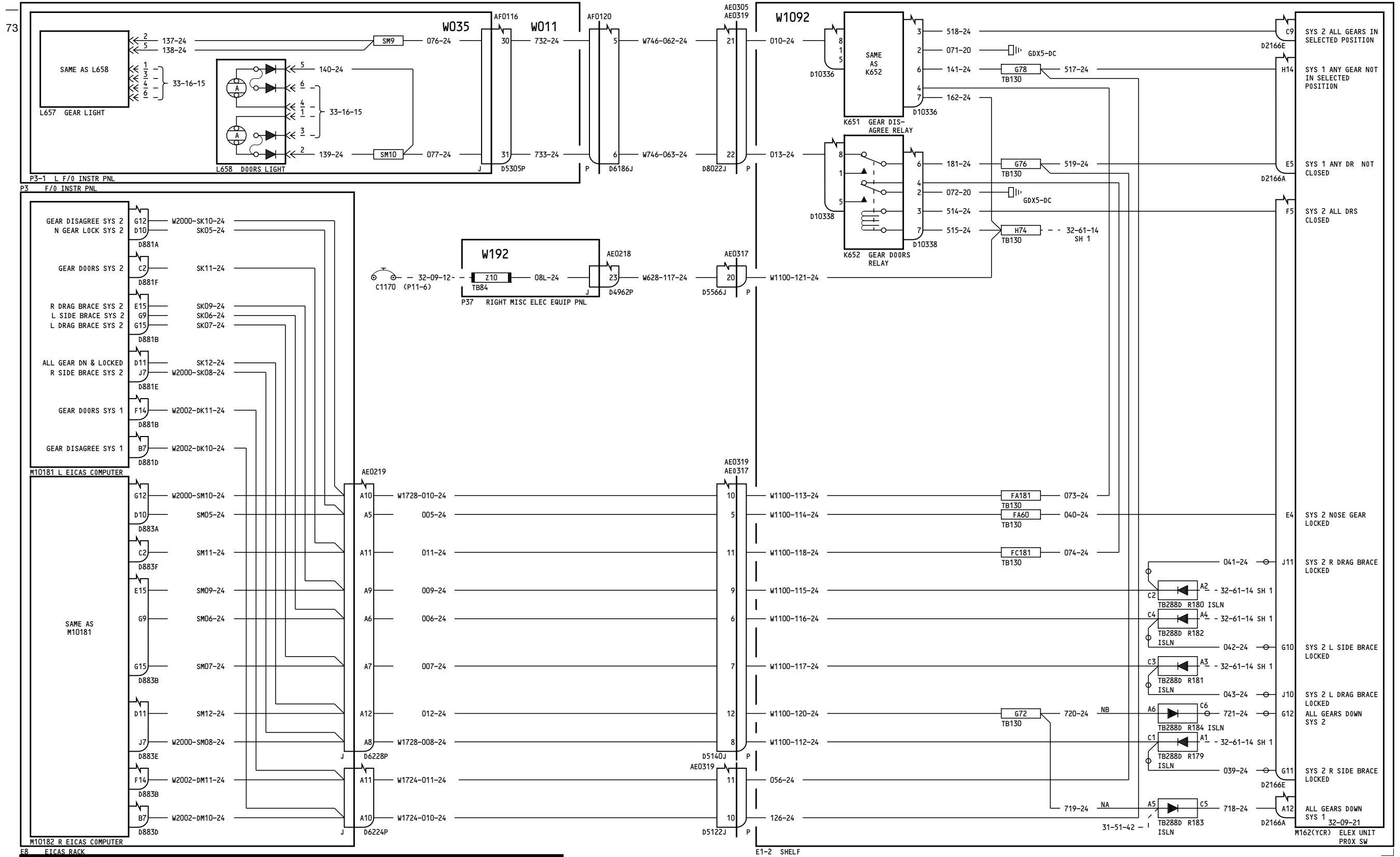

050-051

**LANDING GEAR POSITION INDICATION**

D280T132

**32-61-14**

Page 1A  
Sheet 2  
Jan 21/2005

**32-61-14**

Page 1A  
Sheet 2  
Jan 21/2005

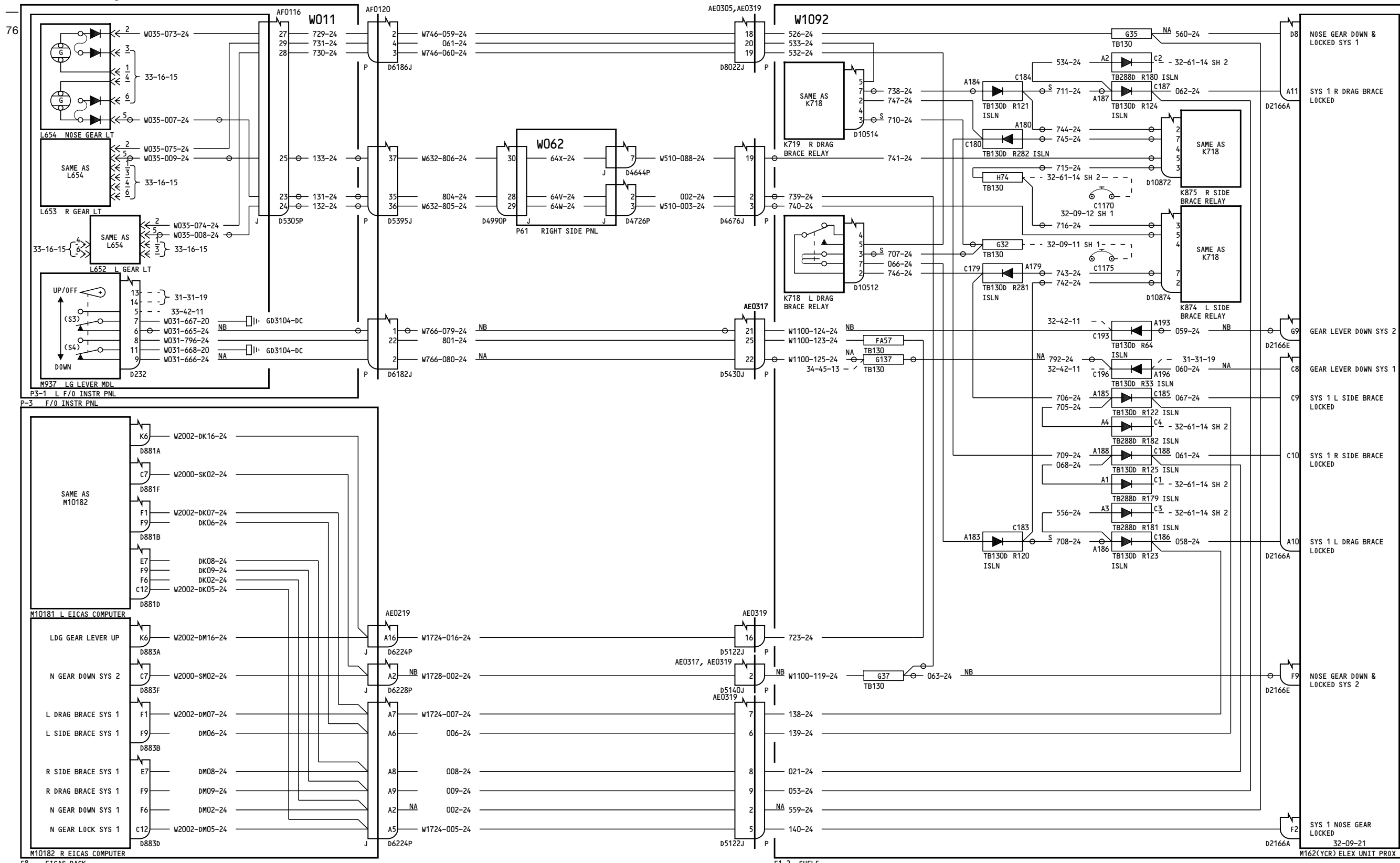

150-152, 155-156, 162-166

LANDING GEAR POSITION INDICATION

D280T132

32-61-14

Page 2A  
Sheet 1  
Jan 21/2005

Incorporates  
MTO 340652

32-61-14

Page 2A  
Sheet 1  
Jan 21/2005



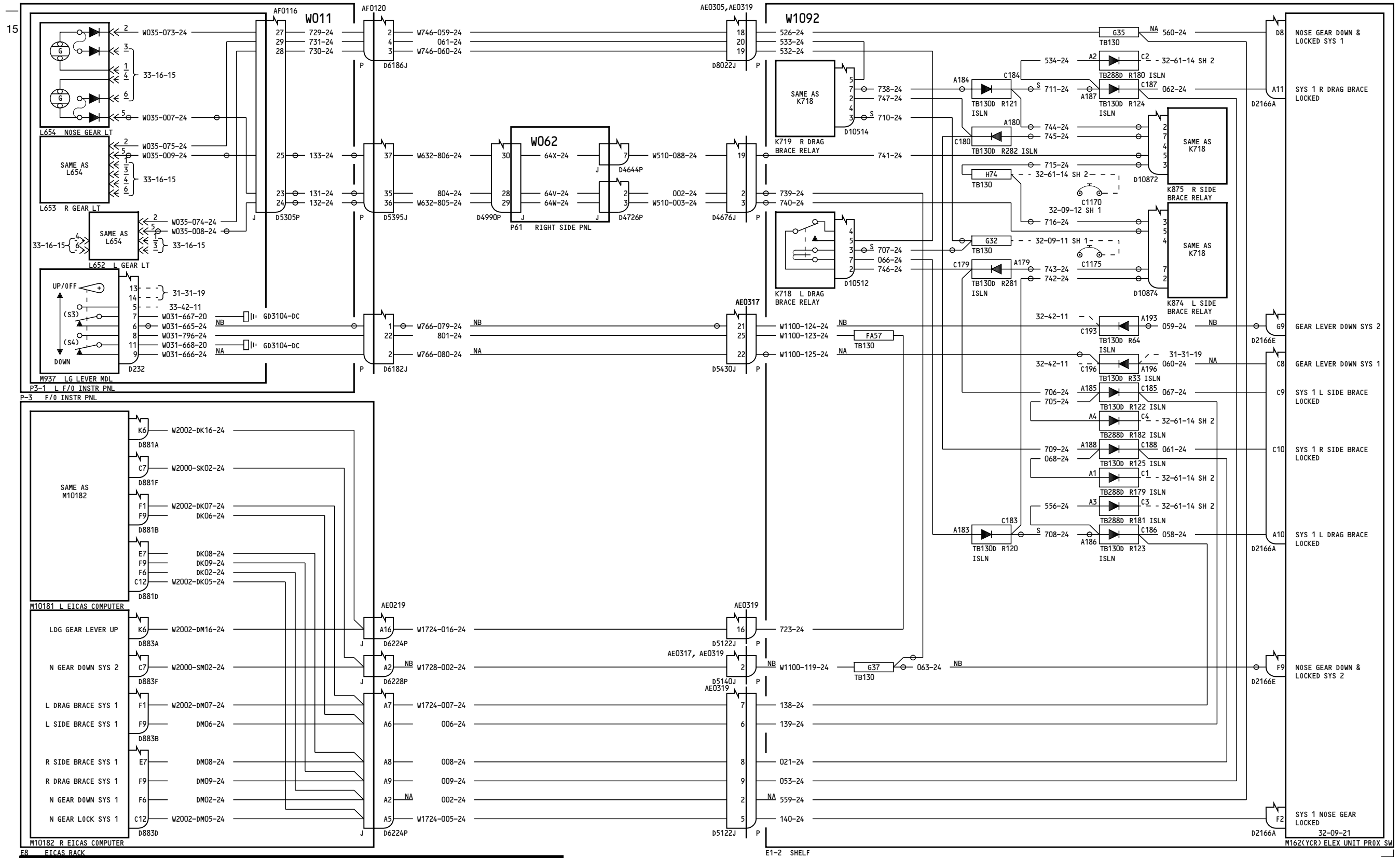

153-154

**LANDING GEAR POSITION INDICATION**

D280T132

**32-61-14**

Page 3  
Sheet 1  
Jan 21/2005

**32-61-14**

Page 3  
Sheet 1  
Jan 21/2005

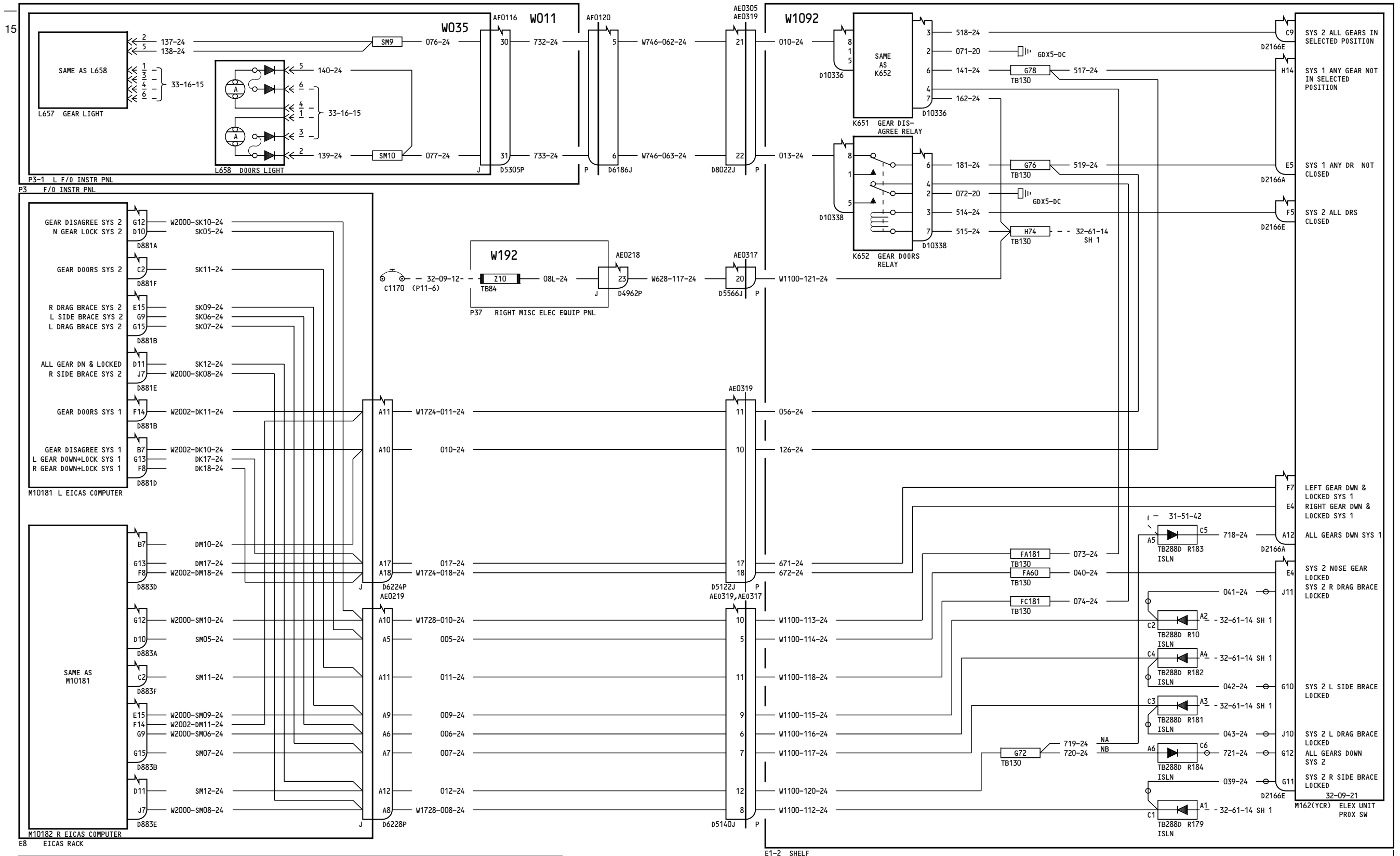

153-154

**LANDING GEAR POSITION INDICATION**

D280T132

**32-61-14**

Page 3  
Sheet 2  
Jan 21/2005

E1-2 SHELF

**32-61-14**

Page 3  
Sheet 2  
Jan 21/2005



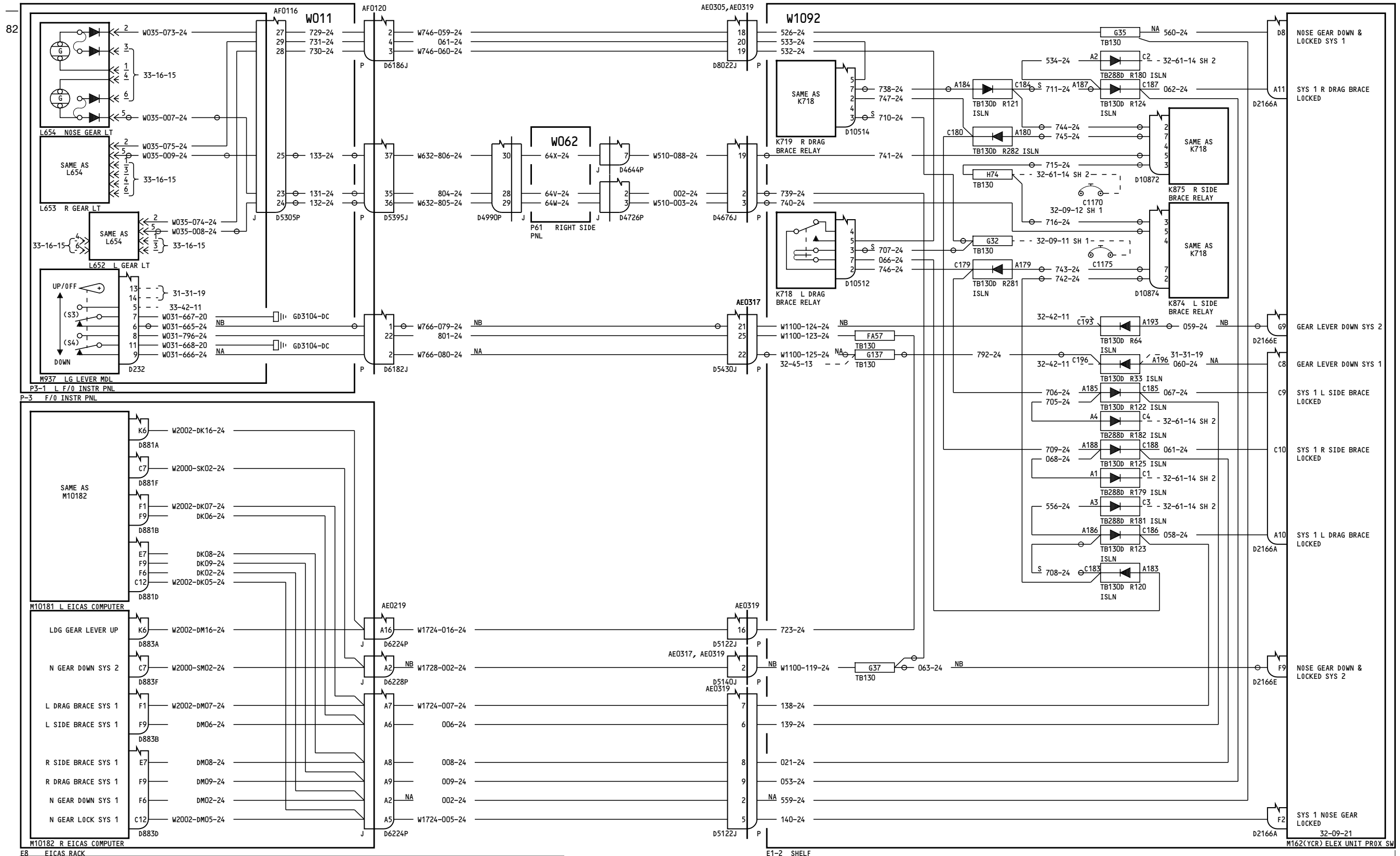

157, 167

LANDING GEAR POSITION INDICATION

D280T132

32-61-14

Page 4A  
Sheet 1  
Jan 21/2005

Incorporates  
MTO 340652

32-61-14

Page 4A  
Sheet 1  
Jan 21/2005

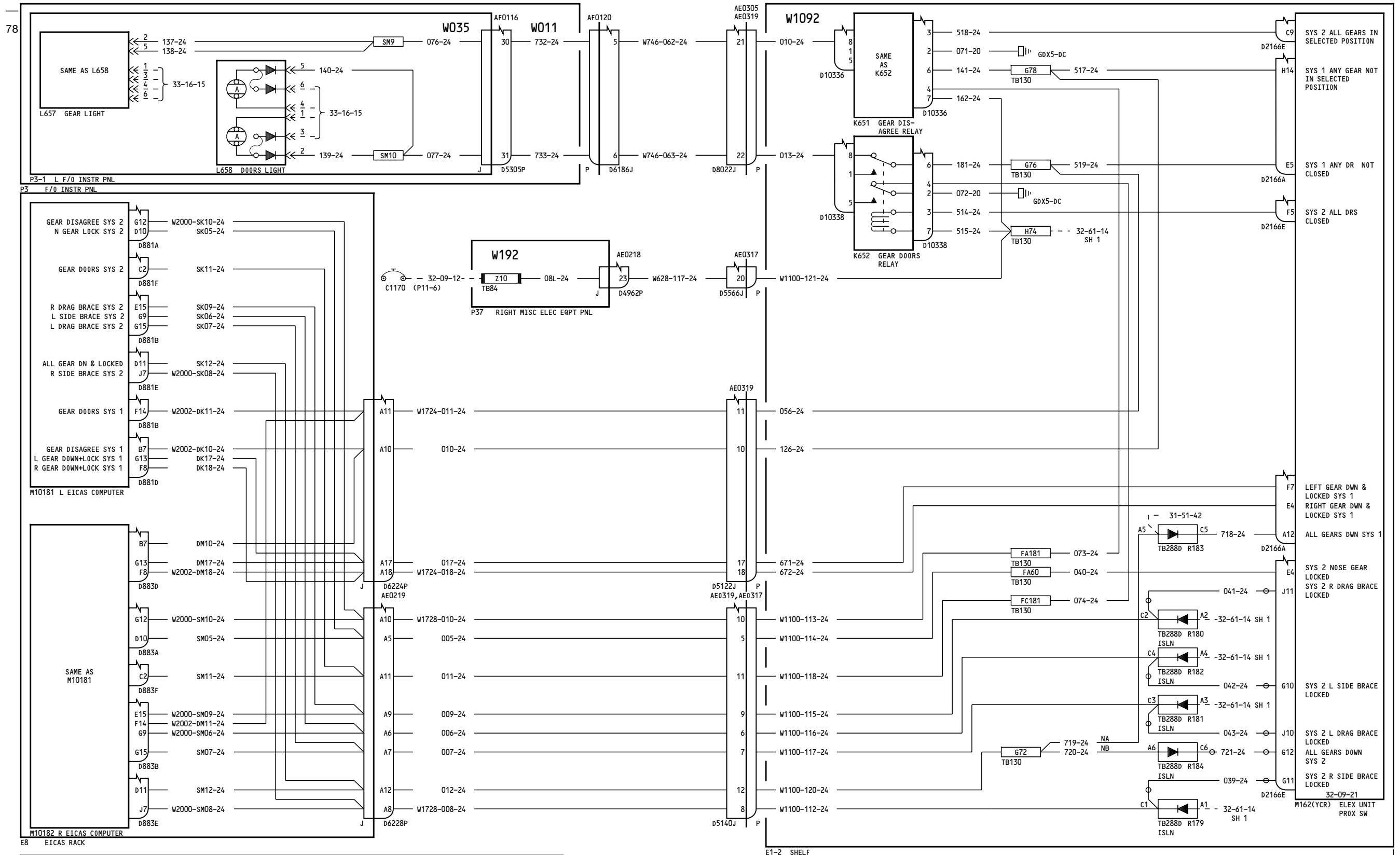

157, 167

LANDING GEAR POSITION INDICATION

32-61-14

Page 4A  
Sheet 2  
Jan 21/2005

D280T132

32-61-14

Page 4A  
Sheet 2  
Jan 21/2005



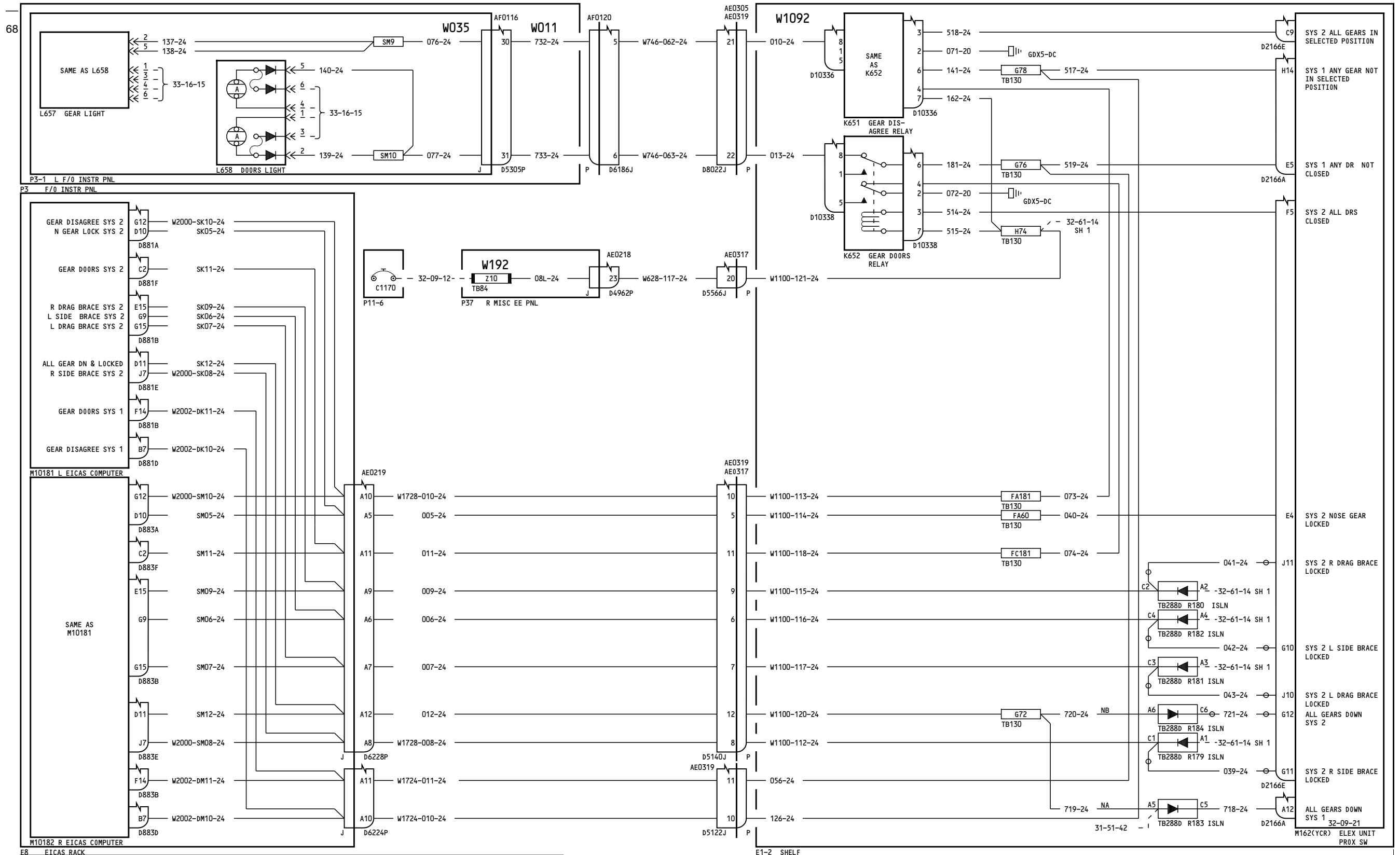

275-276

LANDING GEAR POSITION INDICATION

32-61-14

Page 5A  
Sheet 2  
Jan 21/2005

D280T132

32-61-14

Page 5A  
Sheet 2  
Jan 21/2005



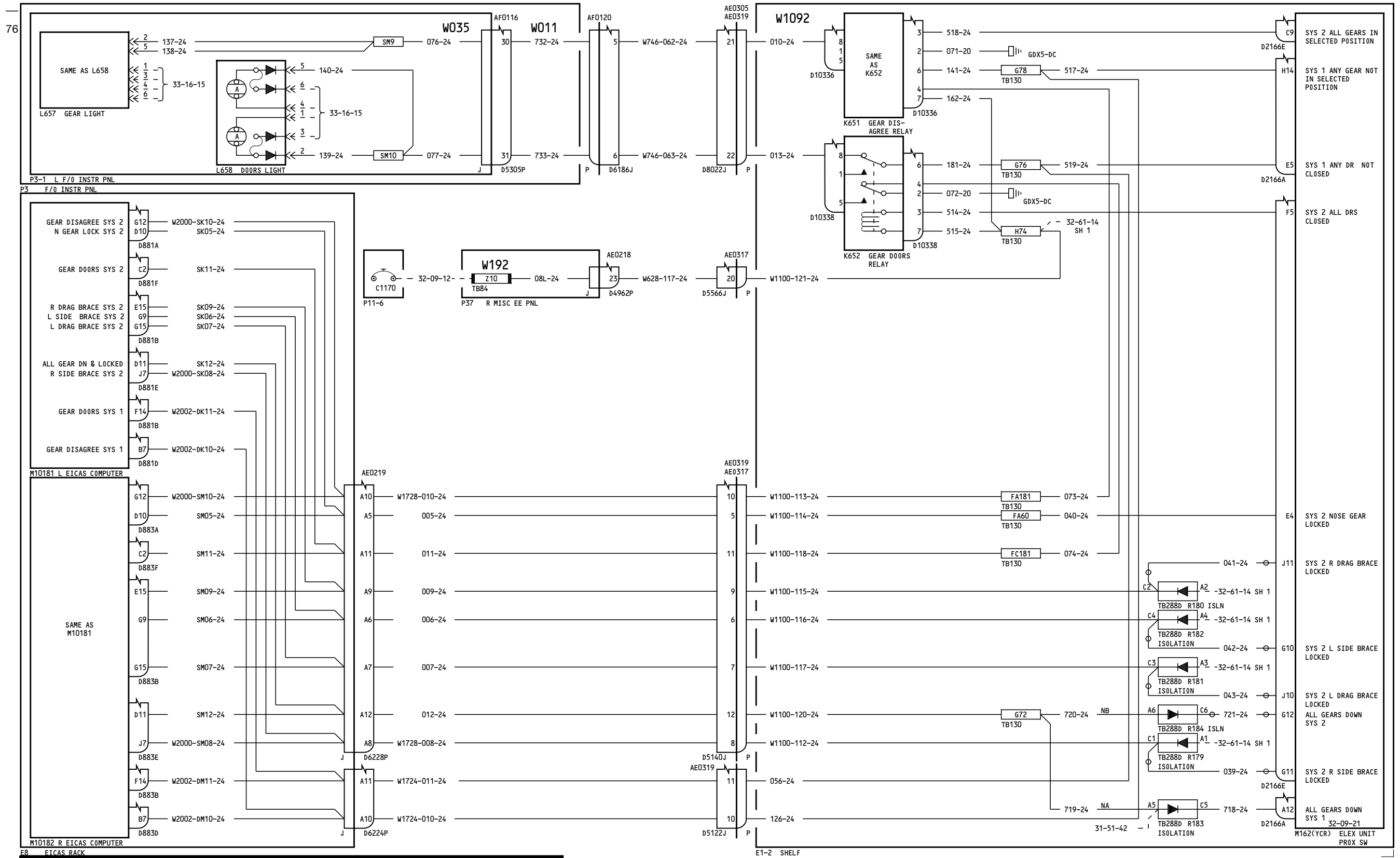

277-278

**LANDING GEAR POSITION INDICATION**

D280T132

**32-61-14**

Page 6A  
Sheet 2  
Jan 21/2005

**32-61-14**

Page 6A  
Sheet 2  
Jan 21/2005

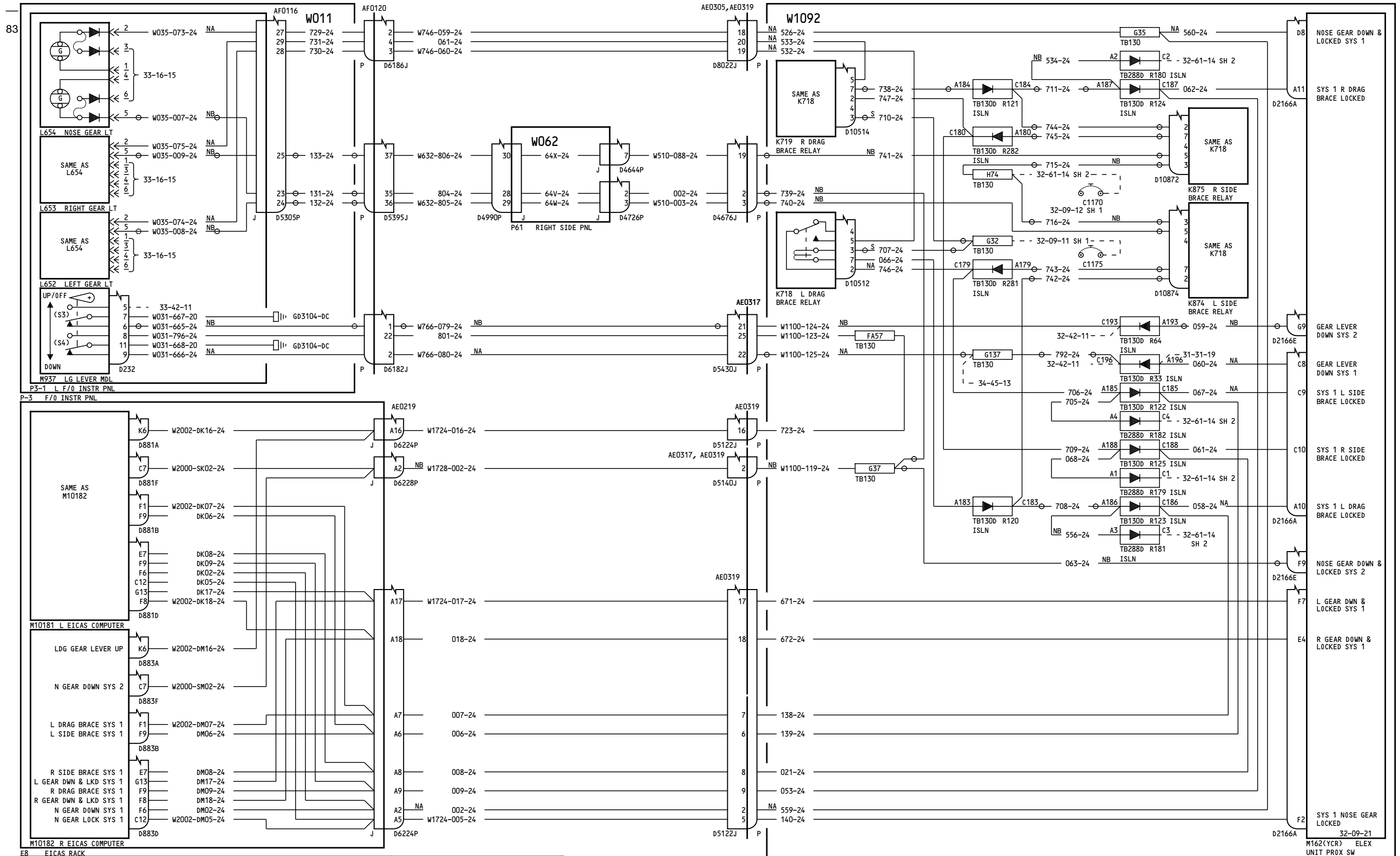

LANDING GEAR POSITION INDICATION

32-61-14

Page 7A  
Sheet 1  
Jan 21/2005

D280T132

E1-2 SHELF Incorporates MTO 340652

32-61-14

Page 7A  
Sheet 1  
Jan 21/2005

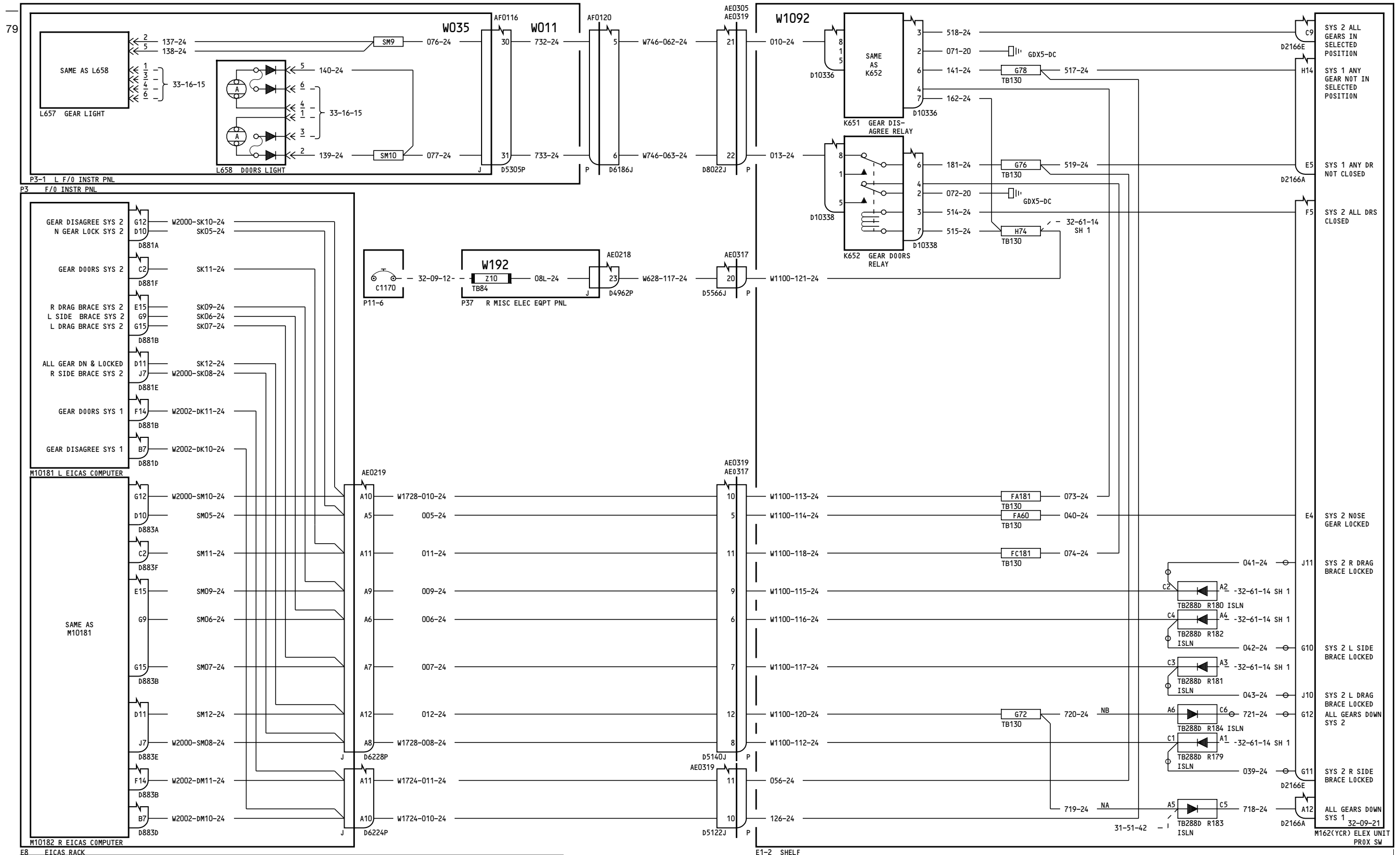

280

**LANDING GEAR POSITION INDICATION**

D280T132

**32-61-14**

Page 7A  
Sheet 2  
Jan 21/2005

**32-61-14**

Page 7A  
Sheet 2  
Jan 21/2005



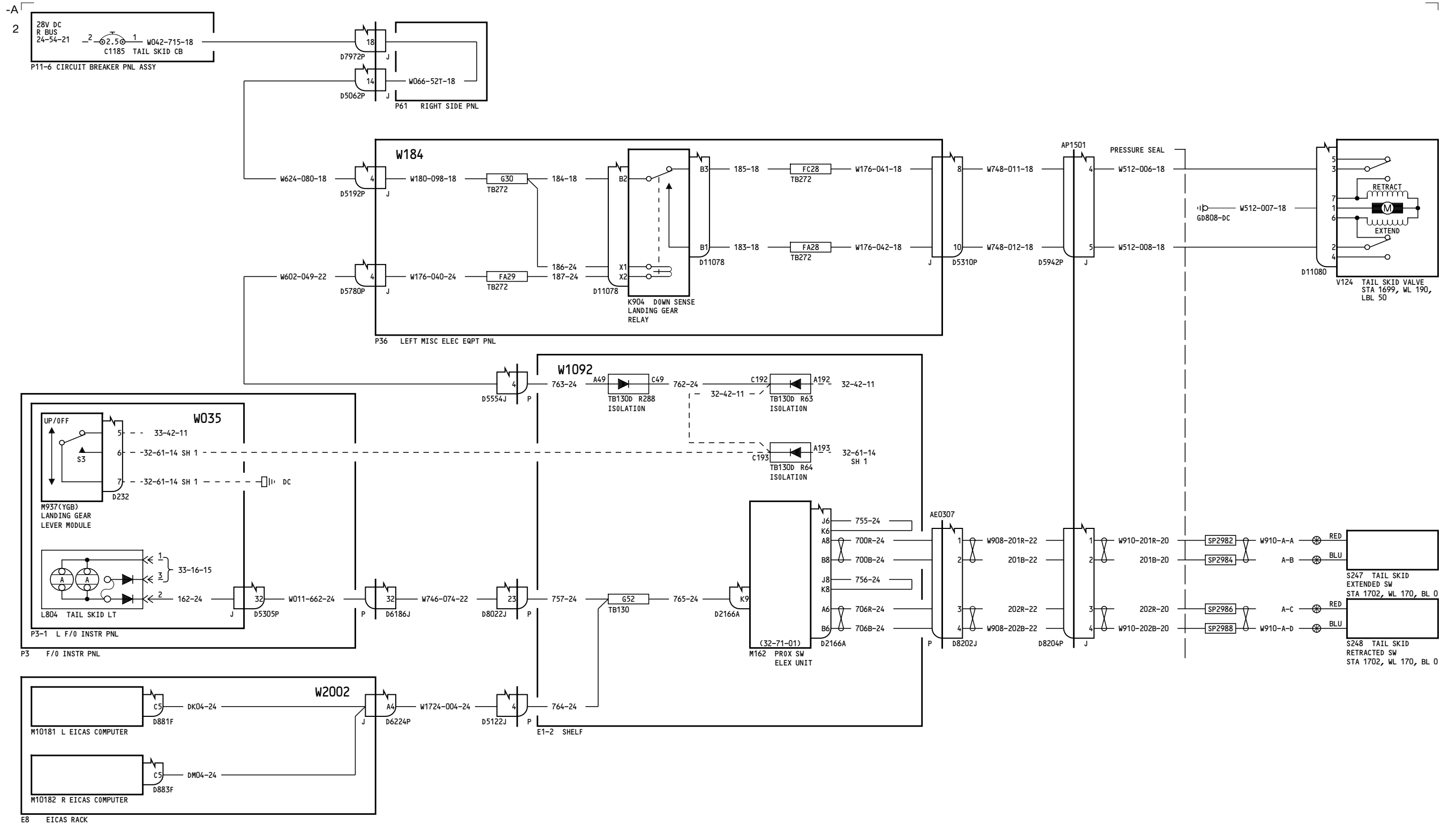

150-199, 275-299

**TAIL SKID CONTROL & INDICATION**

**32-71-11**

Page 1

D280T132

Jan 21/2005

**32-71-11**

Page 1

Jan 21/2005