

CHAPTER

73

**ENGINE FUEL AND
CONTROL**



767-200/300

WIRING DIAGRAM MANUAL

CHAPTER 73
ENGINE FUEL AND CONTROL

CH-SC-SU	Schem	Page	Sheet	Date	CH-SC-SU	Schem	Page	Sheet	Date
73-EFFECTIVE PAGES		1 thru 2		Aug 05/2009	73-21-14 (cont.)		1.1		
								2	Jan 21/2005
73-CONTENTS								3	Jan 21/2005
		1		Mar 14/2007				4	Jan 21/2005
		2		Jun 28/2006		1.2	1	Jan 21/2005	
		3		Jun 28/2006			2	Jan 21/2005	
		4		Jun 28/2006			3	Jan 21/2005	
73-ALPHABETICAL INDEX								4	Jan 21/2005
		1		Jan 21/2005		1.3	1	Jan 21/2005	
		2		BLANK			2	Jan 21/2005	
73-21-11								3	Jan 21/2005
		1	1	Jan 21/2005				4	Jan 21/2005
			2	Jun 28/2006		2.1	1	Jan 21/2005	
			3	Jun 28/2006			2	Jan 21/2005	
			4	Mar 14/2007			3	Jan 21/2005	
			5	Jan 21/2005			4	Jan 21/2005	
			6	Jan 21/2005		2.2	1	Jan 21/2005	
		2.1	1	Jan 21/2005			2	Jan 21/2005	
			2	Jun 28/2006			3	Jan 21/2005	
			3	Jun 28/2006			4	Jan 21/2005	
			4	Mar 14/2007		2.3	1	Jan 21/2005	
			5	Jan 21/2005			2	Jan 21/2005	
			6	Jan 21/2005			3	Jan 21/2005	
			7	Jan 21/2005			4	Jan 21/2005	
		3	1	Jan 21/2005		3	1	Jan 21/2005	
			2	Jun 28/2006			2	Jan 21/2005	
			3	Jun 28/2006			3	Jan 21/2005	
			4	Mar 14/2007			4	Jan 21/2005	
			5	Jan 21/2005		4	1	Jan 21/2005	
			6	Jan 21/2005			2	Jan 21/2005	
		4.1	1	Jan 21/2005			3	Jan 21/2005	
			2	Jun 28/2006			4	Jan 21/2005	
			3	Jun 28/2006	73-21-15				
			4	Mar 14/2007		1	1	Jan 21/2005	
			5	Jan 21/2005			2	Jan 21/2005	
			6	Jan 21/2005		2	1	Jan 21/2005	
			7	Jan 21/2005			2	Jan 21/2005	
		5	1	Jan 21/2005	73-21-16				
			2	Jun 28/2006		1		Jan 21/2005	
			3	Jun 28/2006		2		Jan 21/2005	
			4	Mar 14/2007		2.1		Jan 21/2005	
			5	Jan 21/2005		3		Jan 21/2005	
			6	Jan 21/2005	73-21-17				
73-21-12						1	1	Jan 21/2005	
		1		Jan 21/2005			2	Jan 21/2005	
		2		Jan 21/2005		1.1	1	Jan 21/2005	
		3		Jan 21/2005			2	Jan 21/2005	
73-21-13						1.2	1	Jan 21/2005	
		1		Jan 21/2005			2	Jan 21/2005	
		2		Jan 21/2005		1.3	1	Jan 21/2005	
73-21-14							2	Jan 21/2005	
		1.1	1	Jan 21/2005					

A = Added, R = Revised, D = Deleted, O = Overflow

73-EFFECTIVE PAGES

Page 1
Aug 05/2009

D280T132



767-200/300

WIRING DIAGRAM MANUAL

CHAPTER 73
ENGINE FUEL AND CONTROL

CH-SC-SU	Schem	Page	Sheet	Date	CH-SC-SU	Schem	Page	Sheet	Date
73-21-18		1		Jan 21/2005					
		2.1		Jan 21/2005					
		3		Jan 21/2005					
		4.1		Jan 21/2005					
73-21-19		1.1		Jan 21/2005					
		2.1	1	Jan 21/2005					
			2	Jan 21/2005					
		3		Jan 21/2005					
		3.1		Jan 21/2005					
		4.1		Jan 21/2005					
		5.1		Jan 21/2005					
73-21-20		1		Jan 21/2005					
		2		Jan 21/2005					
73-31-11		1		Jan 21/2005					
73-33-11		1		Jan 21/2005					
		2		Jan 21/2005					
73-34-11		1		Jan 21/2005					
73-41-01		1		Jan 21/2005					

A = Added, R = Revised, D = Deleted, O = Overflow

73-EFFECTIVE PAGES

Page 2
Aug 05/2009

D280T132



767-200/300

WIRING DIAGRAM MANUAL

CHAPTER 73
ENGINE FUEL AND CONTROL

Title	CH-SC-SU	Schem	Page	Sheet	Date	Effectivity
FUEL CONTROL SYSTEM						
ELECTRONIC ENGINE CONTROL & INDICATION DISCRETES	73-21-11		1	1	Jan 21/2005	050-099
				2	Jun 28/2006	050-099
				3	Jun 28/2006	050-099
				4	Mar 14/2007	050-099
				5	Jan 21/2005	050-099
				6	Jan 21/2005	050-099
			2.1	1	Jan 21/2005	150-154
				2	Jun 28/2006	150-154
				3	Jun 28/2006	150-154
				4	Mar 14/2007	150-154
				5	Jan 21/2005	150-154
				6	Jan 21/2005	150-154
				7	Jan 21/2005	150-154
			3	1	Jan 21/2005	155-199
				2	Jun 28/2006	155-199
				3	Jun 28/2006	155-199
				4	Mar 14/2007	155-199
				5	Jan 21/2005	155-199
				6	Jan 21/2005	155-199
			4.1	1	Jan 21/2005	275-276
				2	Jun 28/2006	275-276
				3	Jun 28/2006	275-276
				4	Mar 14/2007	275-276
				5	Jan 21/2005	275-276
				6	Jan 21/2005	275-276
				7	Jan 21/2005	275-276
			5	1	Jan 21/2005	277-299
				2	Jun 28/2006	277-299
				3	Jun 28/2006	277-299
				4	Mar 14/2007	277-299
	5	Jan 21/2005	277-299			

73-CONTENTS



767-200/300

WIRING DIAGRAM MANUAL

**CHAPTER 73
ENGINE FUEL AND CONTROL**

Title	CH-SC-SU	Schem	Page	Sheet	Date	Effectivity
ELECTRONIC ENGINE CONTROL & INDICATION DISCRETES (cont.)	73-21-11			6	Jan 21/2005	277-299
TT2 ELECTRONIC ENGINE CONTROL DISCRETE	73-21-12		1		Jan 21/2005	050-099 150-199
			2		Jan 21/2005	275-276
			3		Jan 21/2005	277-299
THROTTLE LEVER ANGLE RESOLVER	73-21-13		1		Jan 21/2005	050-099 150-156 162-166 275-278
			2		Jan 21/2005	157 167-199 280-299
ELECTRONIC ENGINE CONTROL DATA BUSSES	73-21-14		1.1	1	Jan 21/2005	050-051
				2	Jan 21/2005	050-051
				3	Jan 21/2005	050-051
				4	Jan 21/2005	050-051
			1.2	1	Jan 21/2005	050
				2	Jan 21/2005	050
				3	Jan 21/2005	050
				4	Jan 21/2005	050
			1.3	1	Jan 21/2005	051
				2	Jan 21/2005	051
				3	Jan 21/2005	051
				4	Jan 21/2005	051
			2.1	1	Jan 21/2005	150-154 162-165 275-276
				2	Jan 21/2005	150-154 162-165 275-276
				3	Jan 21/2005	150-154 162-165 275-276
				4	Jan 21/2005	150-154 162-165 275-276
			2.2	1	Jan 21/2005	151
				2	Jan 21/2005	151
				3	Jan 21/2005	151
				4	Jan 21/2005	151
	2.3	1	Jan 21/2005	153		
		2	Jan 21/2005	153		
		3	Jan 21/2005	153		
		4	Jan 21/2005	153		

73-CONTENTS



767-200/300

WIRING DIAGRAM MANUAL

CHAPTER 73
ENGINE FUEL AND CONTROL

Title	CH-SC-SU	Schem	Page	Sheet	Date	Effectivity
ELECTRONIC ENGINE CONTROL DATA BUSES (cont.)	73-21-14		3	1	Jan 21/2005	155-157 166-199
				2	Jan 21/2005	155-157 166-199
				3	Jan 21/2005	155-157 166-199
				4	Jan 21/2005	155-157 166-199
			4	1	Jan 21/2005	277-299
				2	Jan 21/2005	277-299
				3	Jan 21/2005	277-299
				4	Jan 21/2005	277-299
ELECTRONIC ENGINE CONTROL ENVIRONMENTAL CONTROL SYSTEM DISCRETES	73-21-15		1	1	Jan 21/2005	050-099 153-199 277-299
				2	Jan 21/2005	050-099 153-199 277-299
			2	1	Jan 21/2005	150-152 275-276
ELECTRONIC ENGINE CONTROL ANTI-ICE DISCRETES	73-21-16			2	Jan 21/2005	150-152 275-276
				2	Jan 21/2005	150-152 275-276
			1		Jan 21/2005	050-099
			2		Jan 21/2005	150-154 275-299
ELECTRONIC ENGINE CONTROL DISCRETES	73-21-17		1	1	Jan 21/2005	ALL
				2	Jan 21/2005	ALL
			1.1	1	Jan 21/2005	050
				2	Jan 21/2005	050
			1.2	1	Jan 21/2005	051
				2	Jan 21/2005	051
			1.3	1	Jan 21/2005	153
	2	Jan 21/2005	153			
ENGINE N2 DISCRETES	73-21-18		1		Jan 21/2005	050-099 277-299
				2.1	Jan 21/2005	150-154
				3	Jan 21/2005	155-199

73-CONTENTS



767-200/300

WIRING DIAGRAM MANUAL

**CHAPTER 73
ENGINE FUEL AND CONTROL**

Title	CH-SC-SU	Schem	Page	Sheet	Date	Effectivity
ENGINE N2 DISCRETES (cont.)	73-21-18		4.1		Jan 21/2005	275-276
FLIGHT/GROUND IDLE	73-21-19		1.1		Jan 21/2005	050 155-167
			2.1	1	Jan 21/2005	051
				2	Jan 21/2005	051
			3		Jan 21/2005	150-154
			3.1		Jan 21/2005	150-154
			4.1		Jan 21/2005	275-276
PERFORMANCE SOLENOID POWER	73-21-20		5.1		Jan 21/2005	277-280
			1		Jan 21/2005	050-099 150-199 277-299
			2		Jan 21/2005	275-276
<u>FUEL FLOW INDICATING SYSTEM</u>						
FUEL FLOW INDICATING SYSTEM	73-31-11		1		Jan 21/2005	ALL
<u>FUEL PRESSURE INDICATING SYSTEM</u>						
ENGINE FUEL PRESSURE INDICATION	73-33-11		1		Jan 21/2005	050-099 150-157 275-299
			2		Jan 21/2005	162-199
<u>FUEL FILTER BYPASS WARNING SYSTEM</u>						
ENGINE FUEL FILTER BYPASS WARNING	73-34-11		1		Jan 21/2005	ALL
<u>ELECTRONIC ENGINE CONTROL LIGHTNING PROTECTION</u>						
ELECTRONIC ENGINE CONTROL LIGHTNING PROTECTION	73-41-01		1		Jan 21/2005	ALL



767-200/300

WIRING DIAGRAM MANUAL

CHAPTER 73 ENGINE FUEL AND CONTROL

CH-SC-SU	Title
73-21-11	ELECTRONIC ENGINE CONTROL & INDICATION DISCRETES
73-21-16	ELECTRONIC ENGINE CONTROL ANTI-ICE DISCRETES
73-21-14	ELECTRONIC ENGINE CONTROL DATA BUSES
73-21-17	ELECTRONIC ENGINE CONTROL DISCRETES
73-21-15	ELECTRONIC ENGINE CONTROL ENVIRONMENTAL CONTROL SYSTEM DISCRETES
73-41-01	ELECTRONIC ENGINE CONTROL LIGHTNING PROTECTION
73-34-11	ENGINE FUEL FILTER BYPASS WARNING
73-33-11	ENGINE FUEL PRESSURE INDICATION
73-21-18	ENGINE N2 DISCRETES
73-21-19	FLIGHT/GROUND IDLE
73-31-11	FUEL FLOW INDICATING SYSTEM
73-21-20	PERFORMANCE SOLENOID POWER
73-21-13	THROTTLE LEVER ANGLE RESOLVER
73-21-12	TT2 ELECTRONIC ENGINE CONTROL DISCRETE

73-ALPHABETICAL INDEX

D280T132

Page 1
Jan 21/2005

-A
51

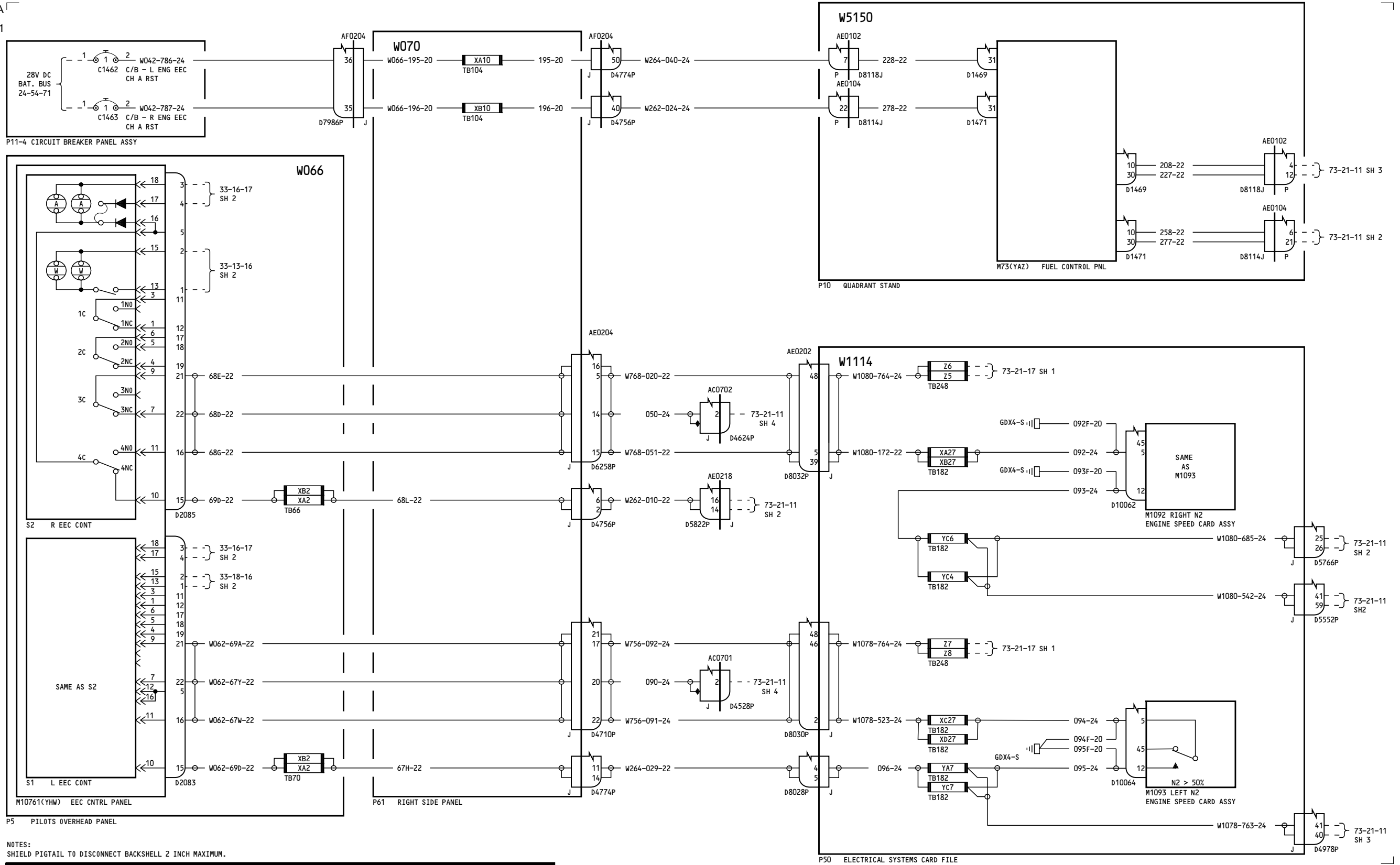

NOTES:
SHIELD PIGTAIL TO DISCONNECT BACKSHELL 2 INCH MAXIMUM.

050-099

ELECTRONIC ENGINE CONTROL & INDICATION DISCRETIVES

D280T132

73-21-11
Page 1
Sheet 1
Jan 21/2005

73-21-11
Page 1
Sheet 1
Jan 21/2005

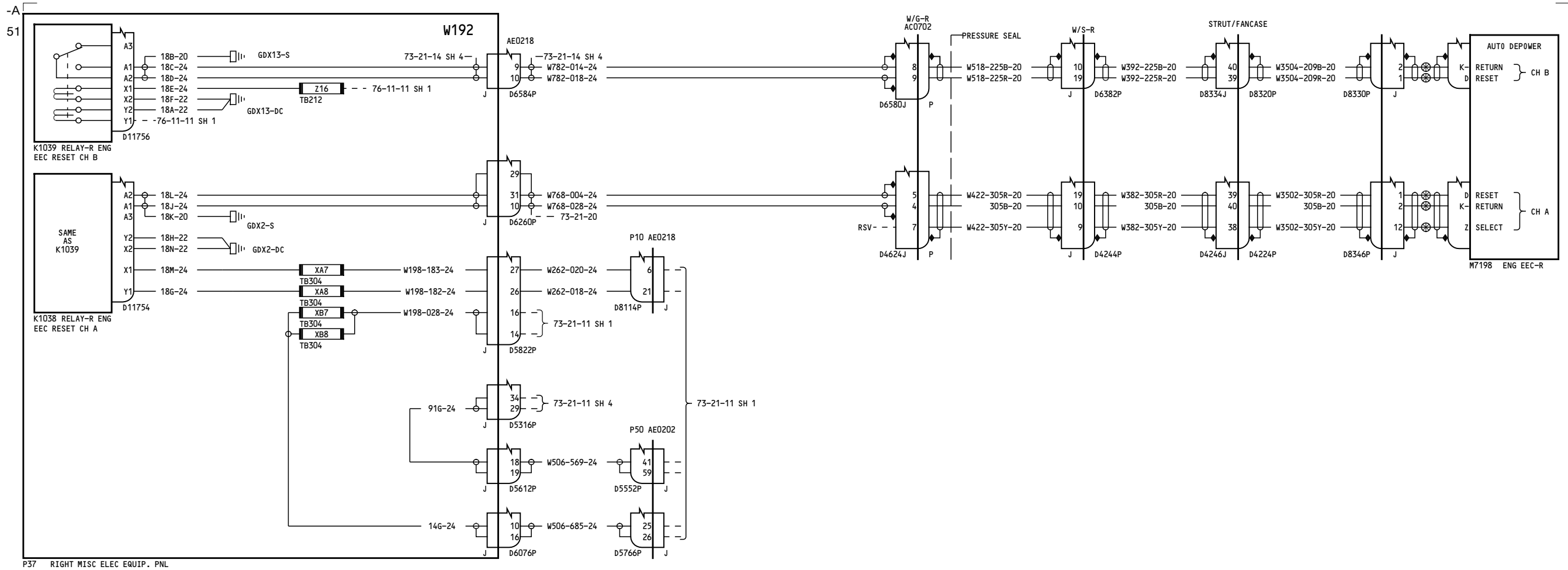

P37 RIGHT MISC ELEC EQUIP. PNL

NOTES:
SHIELD PIGTAIL TO DISCONNECT BACKSHELL 2 INCH MAXIMUM

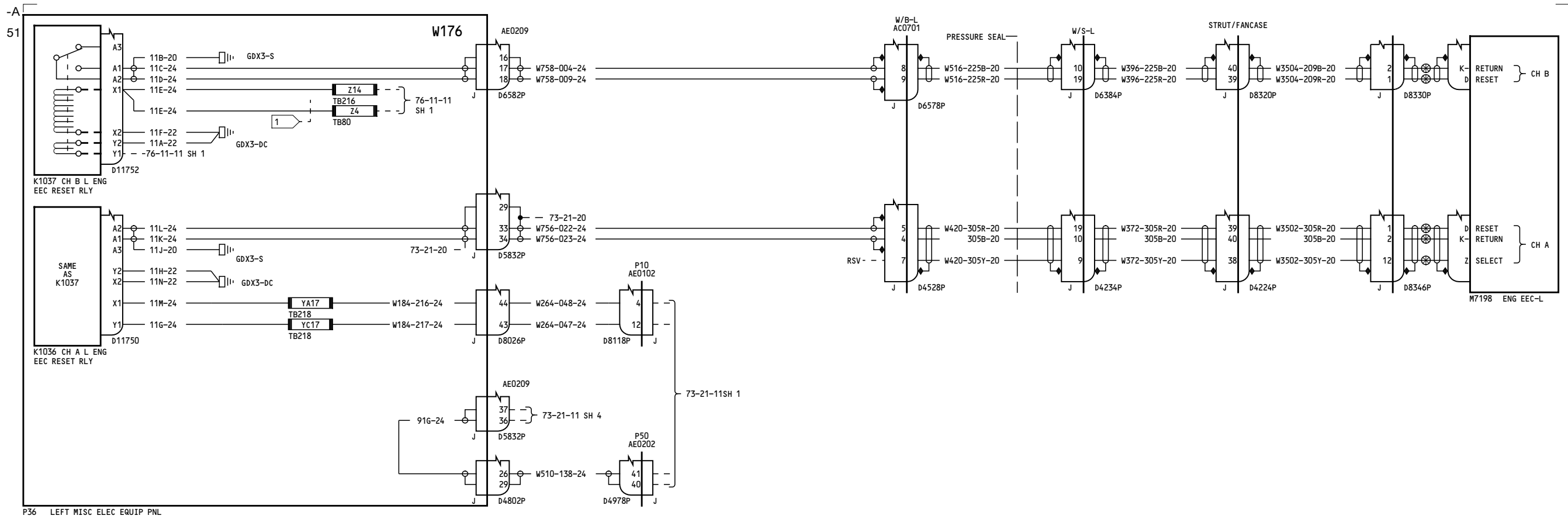

NOTES:
SHIELD PIGTAIL TO DISCONNECT BACKSHELL 2 INCH MAXIMUM

1 VF073-VF090

050-099

**ELECTRONIC ENGINE
CONTROL & INDICATION
DISCRETES**

D280T132

73-21-11

Page 1
Sheet 3
Jun 28/2006

73-21-11

Page 1
Sheet 3
Jun 28/2006

-A
51

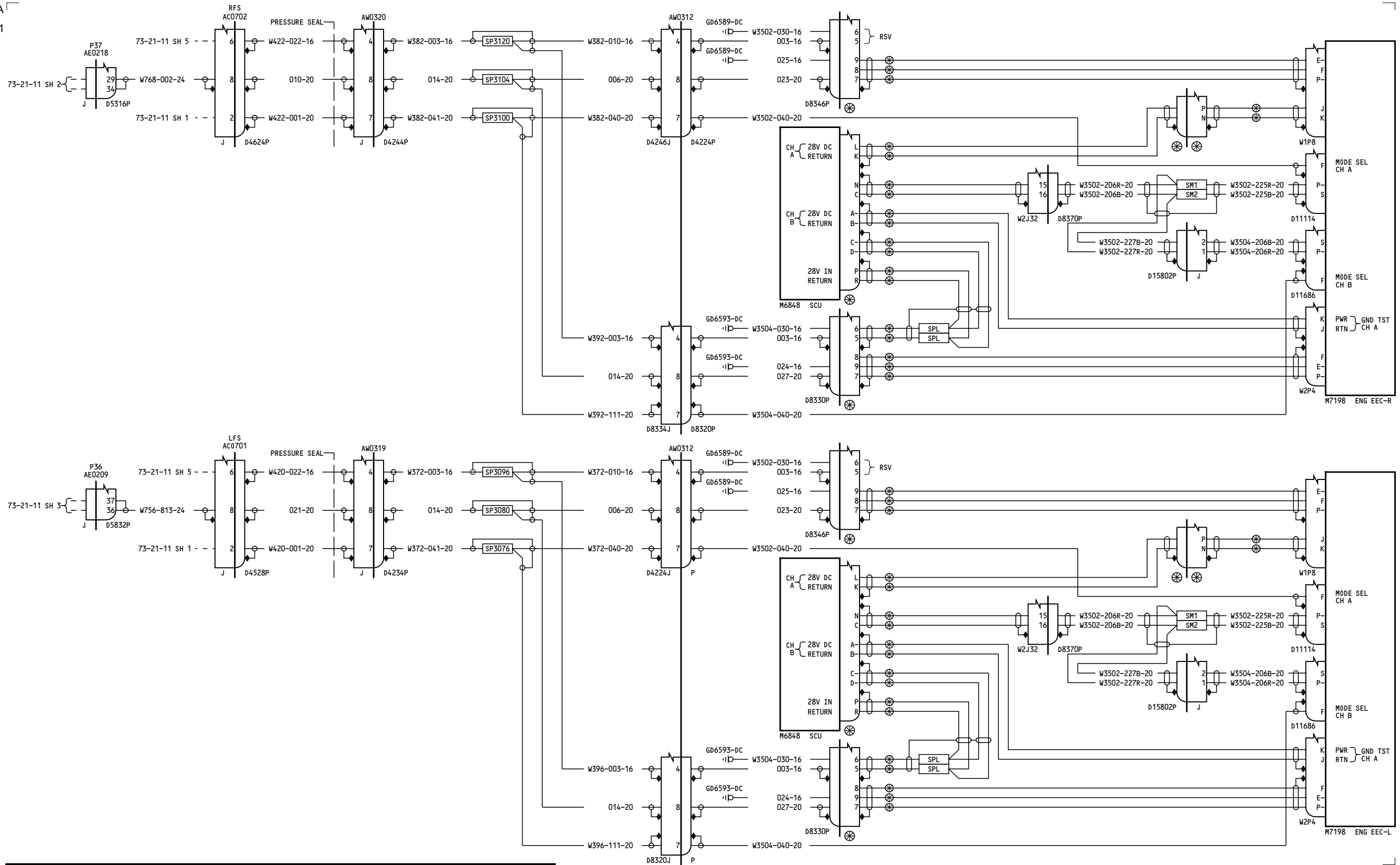

050-099

ELECTRONIC ENGINE CONTROL & INDICATION DISCRETES

D280T132

73-21-11

Page 1
Sheet 4
Mar 14/2007

73-21-11

Page 1
Sheet 4
Mar 14/2007

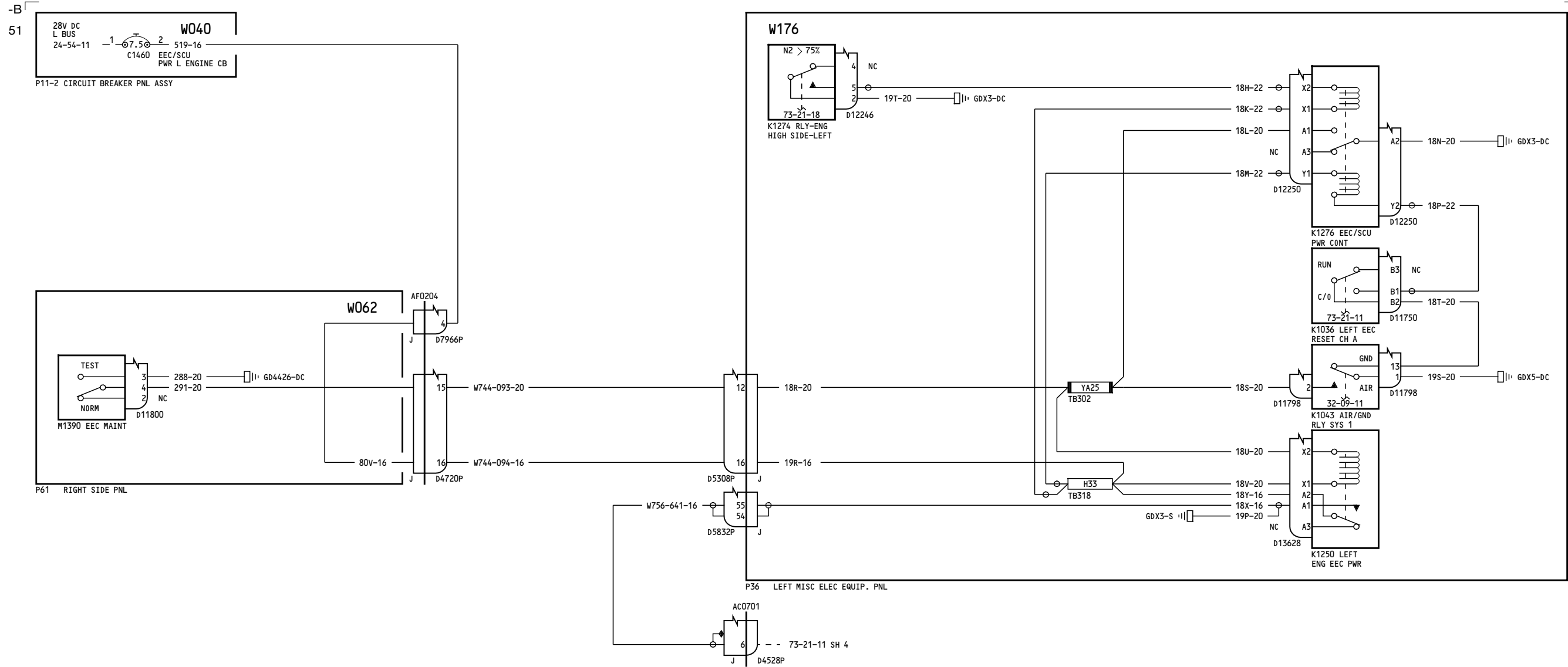

NOTES:
SHIELD PIGTAIL TO DISCONNECT BACKSHELL 2 INCH MAXIMUM

050-099

ELECTRONIC ENGINE CONTROL & INDICATION DISCRETES

D280T132

73-21-11

Page 1
Sheet 5
Jan 21/2005

73-21-11

Page 1
Sheet 5
Jan 21/2005

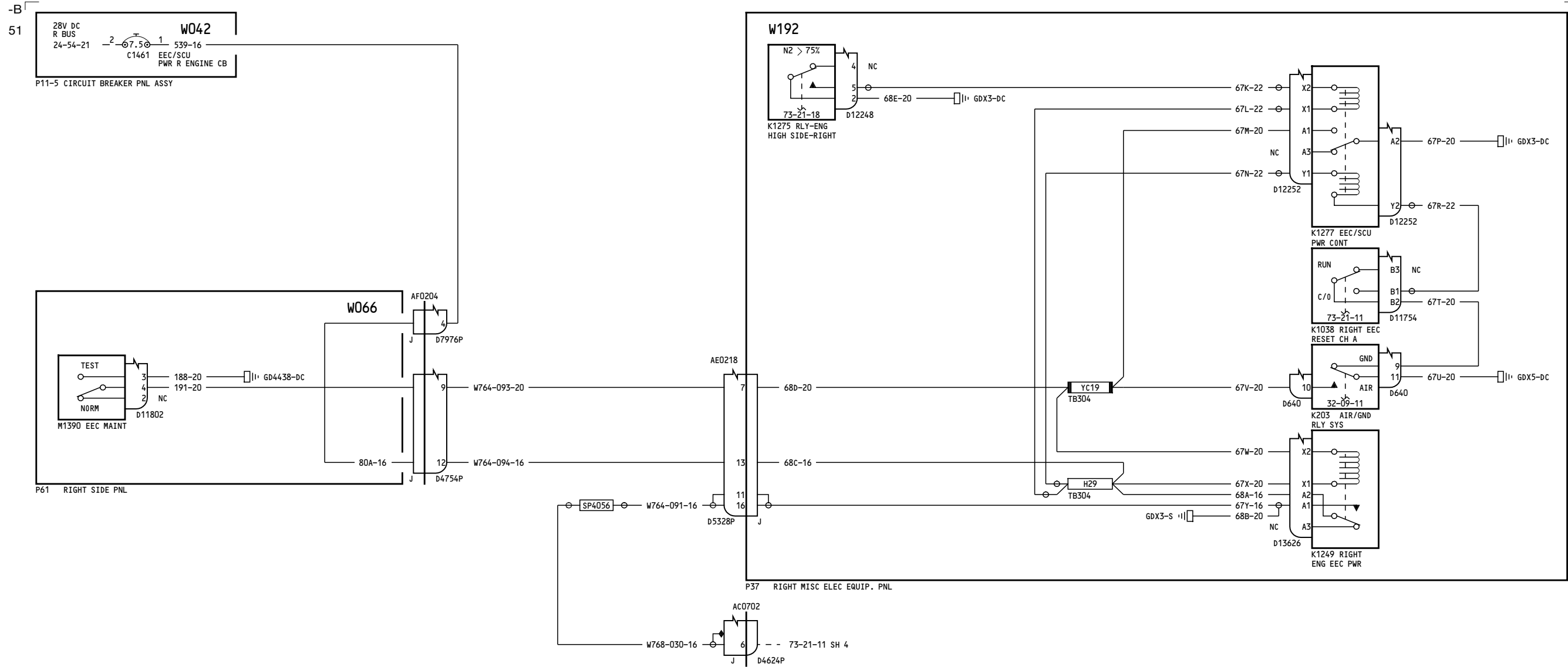

NOTES:
SHIELD PIGTAIL TO DISCONNECT BACKSHELL 2 INCH MAXIMUM

050-099

ELECTRONIC ENGINE CONTROL & INDICATION DISCRETES

D280T132

73-21-11

Page 1
Sheet 6
Jan 21/2005

73-21-11

Page 1
Sheet 6
Jan 21/2005

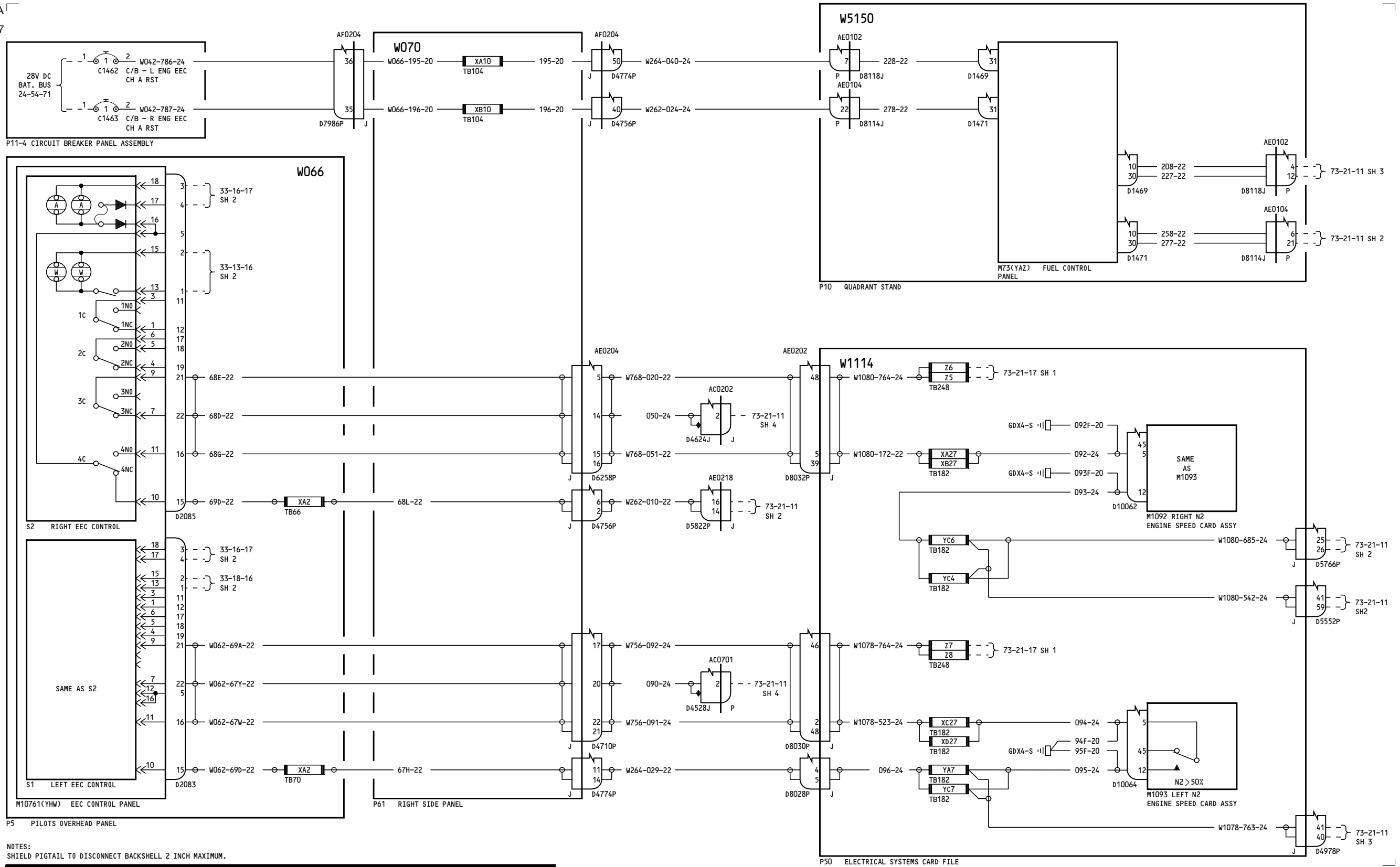

NOTES:
SHIELD PIGTAIL TO DISCONNECT BACKSHELL 2 INCH MAXIMUM.

150-154

ELECTRONIC ENGINE CONTROL & INDICATION DISCRETIVES

D280T132

73-21-11
Page 2.1
Sheet 1
Jan 21/2005

Incorporates
76-0030 R02

73-21-11
Page 2.1
Sheet 1
Jan 21/2005

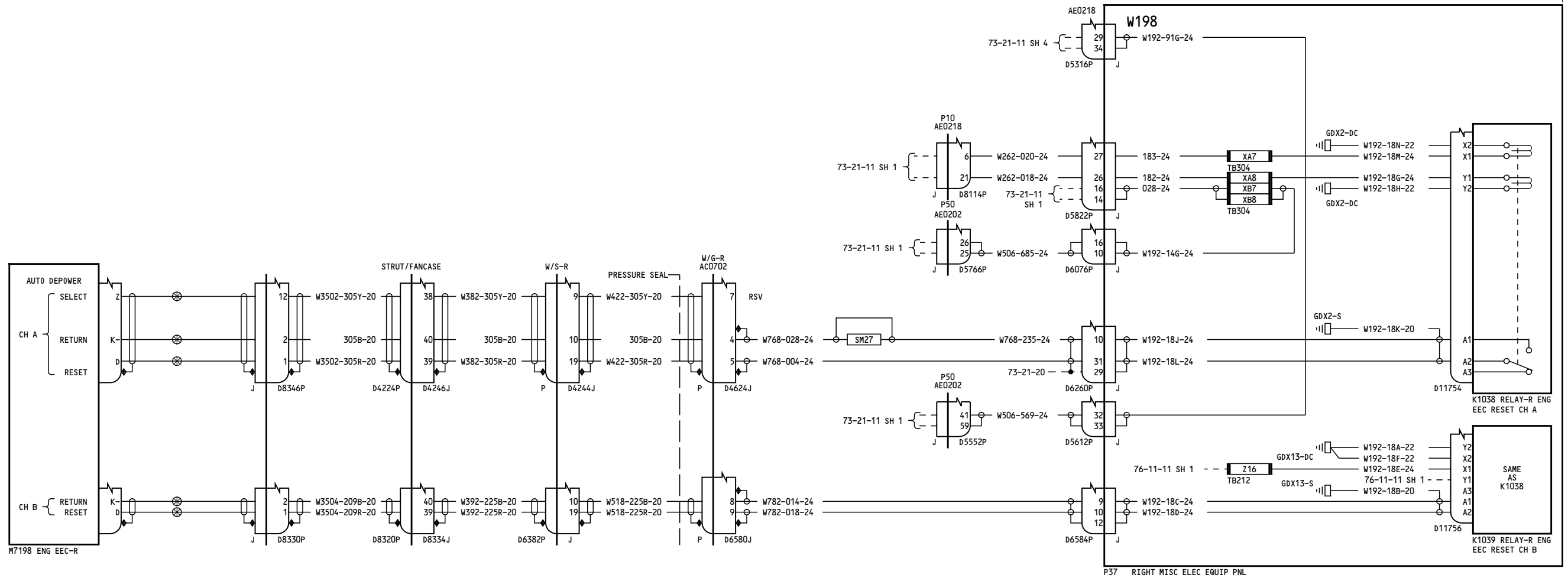

NOTES:
SHIELD PIGTAIL TO DISCONNECT BACKSHELL 2 INCH MAXIMUM

150-154

ELECTRONIC ENGINE CONTROL & INDICATION DISCRETES

D280T132

73-21-11

Page 2.1
Sheet 2
Jun 28/2006

Incorporates
76-0030 R02

73-21-11

Page 2.1
Sheet 2
Jun 28/2006

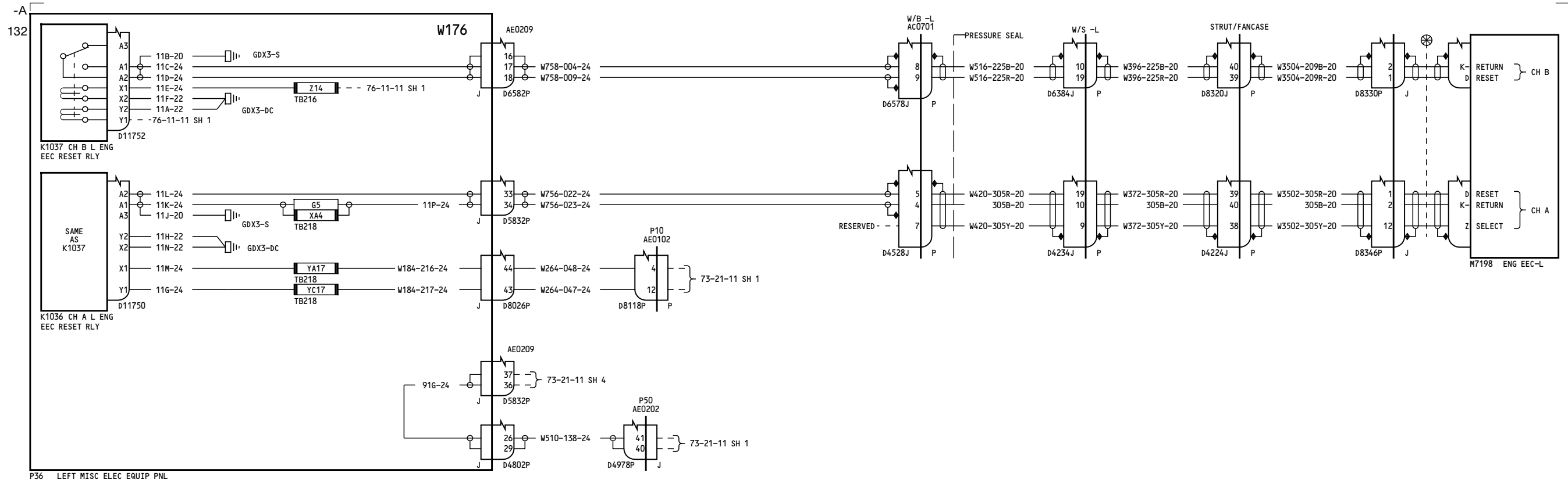

NOTES:
SHIELD PIGTAIL TO DISCONNECT BACKSHELL 2 INCH MAXIMUM

150-154

**ELECTRONIC ENGINE
CONTROL & INDICATION
DISCRETES**

D280T132

73-21-11

Page 2.1
Sheet 3
Jun 28/2006

Incorporates
76-0030 R02

73-21-11

Page 2.1
Sheet 3
Jun 28/2006

-A
103

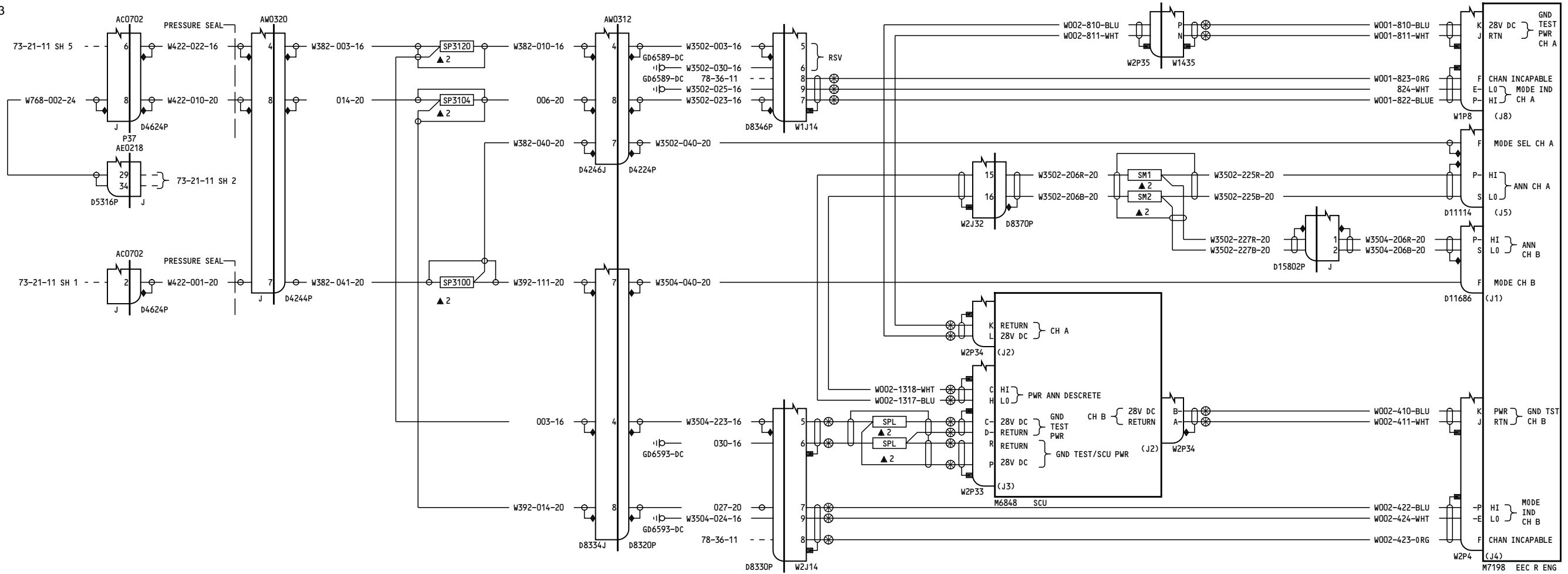

NOTES:
SHIELD PIGTAIL TO DISCONNECT BACKSHELL 2 INCH MAXIMUM

150-154

ELECTRONIC ENGINE CONTROL & INDICATION DISCRETIVES

D280T132

73-21-11

Page 2.1
Sheet 4
Mar 14/2007

Incorporates
76-0030 R02

73-21-11

Page 2.1
Sheet 4
Mar 14/2007

-B

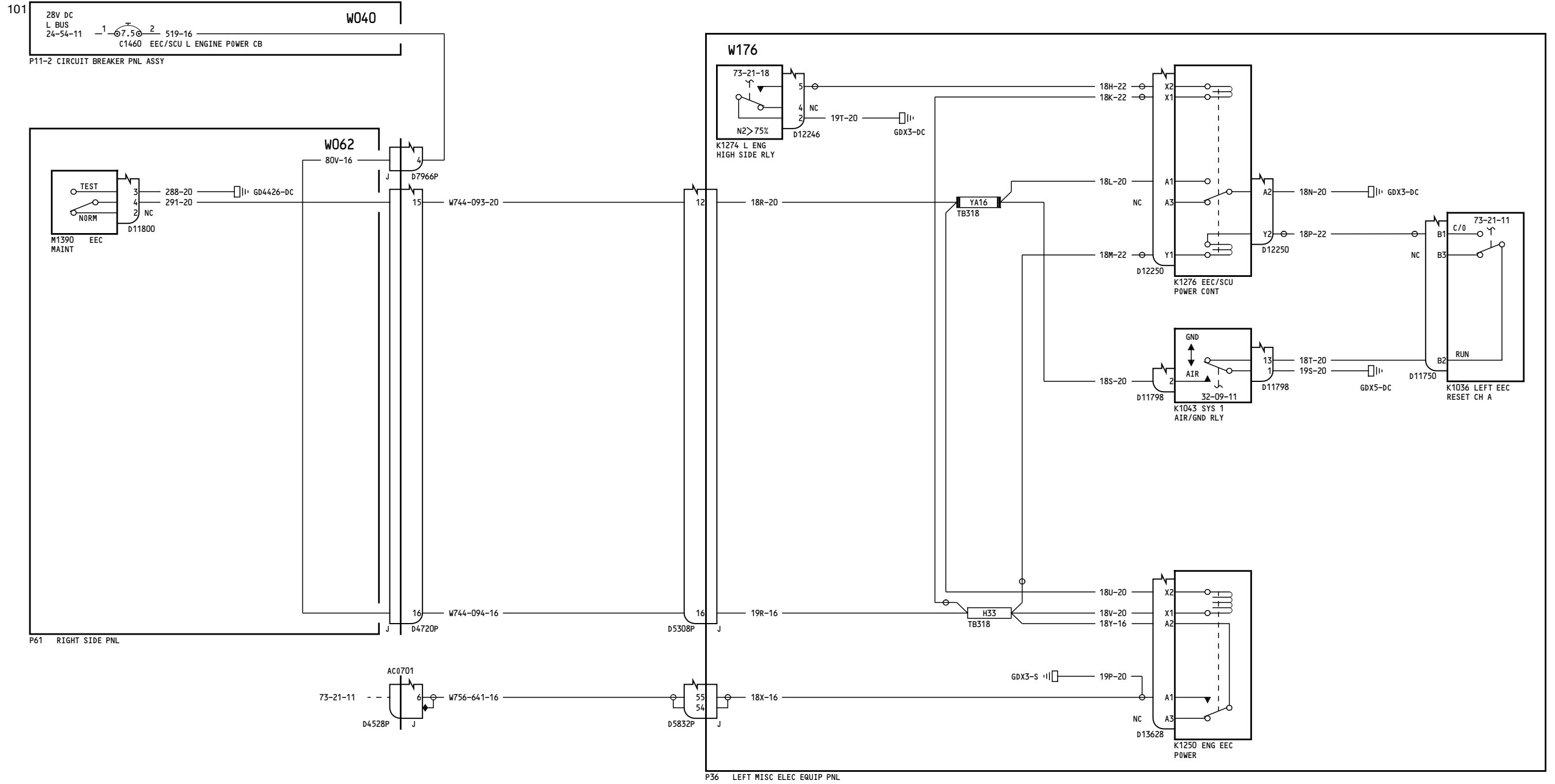

NOTES:
SHEILD PIGTAIL TO DISCONNECT BACKSHELL 2 INCH MAXIMUM

150-154

ELECTRONIC ENGINE CONTROL & INDICATION DISCRETES

D280T132

73-21-11

Page 2.1
Sheet 5
Jan 21/2005

Incorporates
76-0030 R02

73-21-11

Page 2.1
Sheet 5
Jan 21/2005

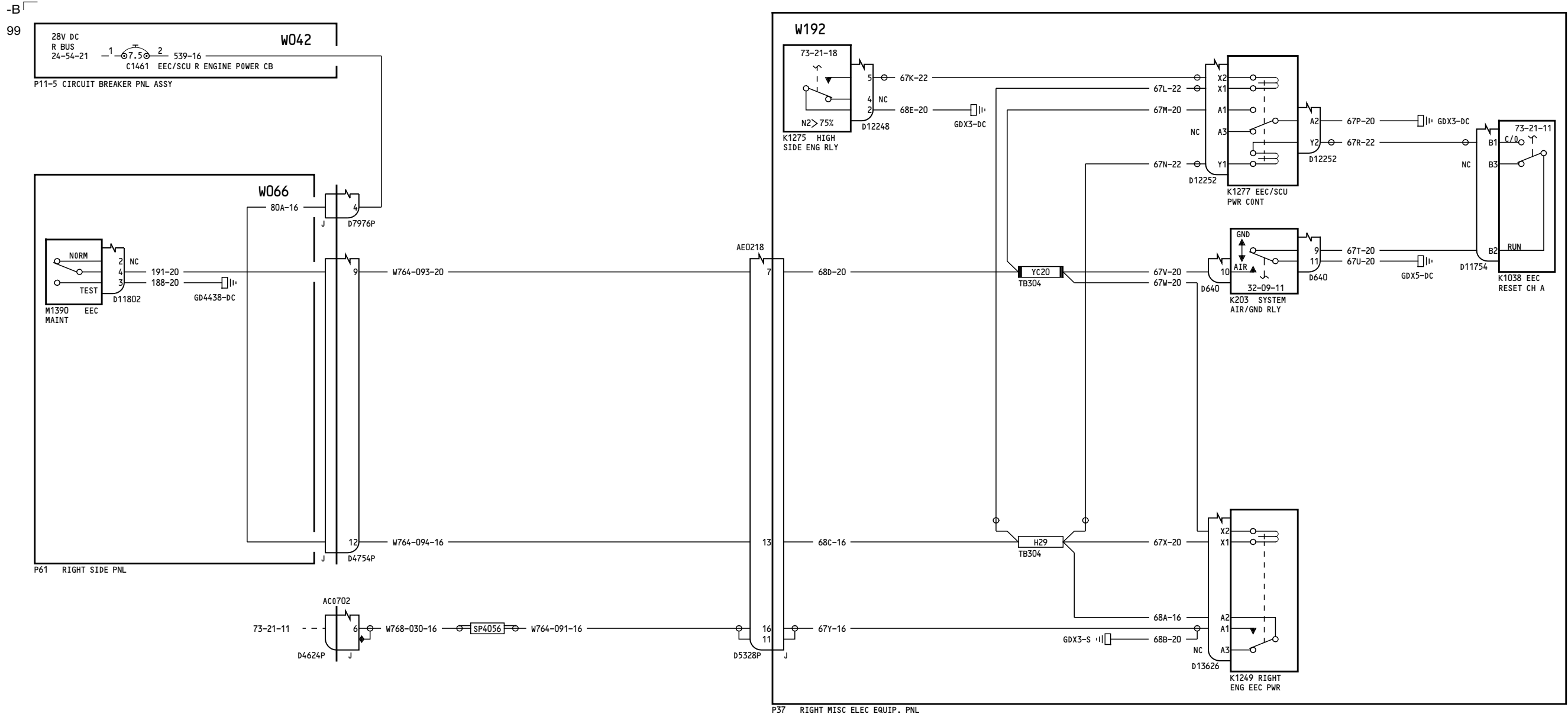

NOTES:
SHIELD PIGTAIL TO DISCONNECT 2 INCH MAXIMUM

150-154

ELECTRONIC ENGINE CONTROL & INDICATION DISCRETES

D280T132

73-21-11

Page 2.1
Sheet 6
Jan 21/2005

Incorporates
76-0030 R02

73-21-11

Page 2.1
Sheet 6
Jan 21/2005

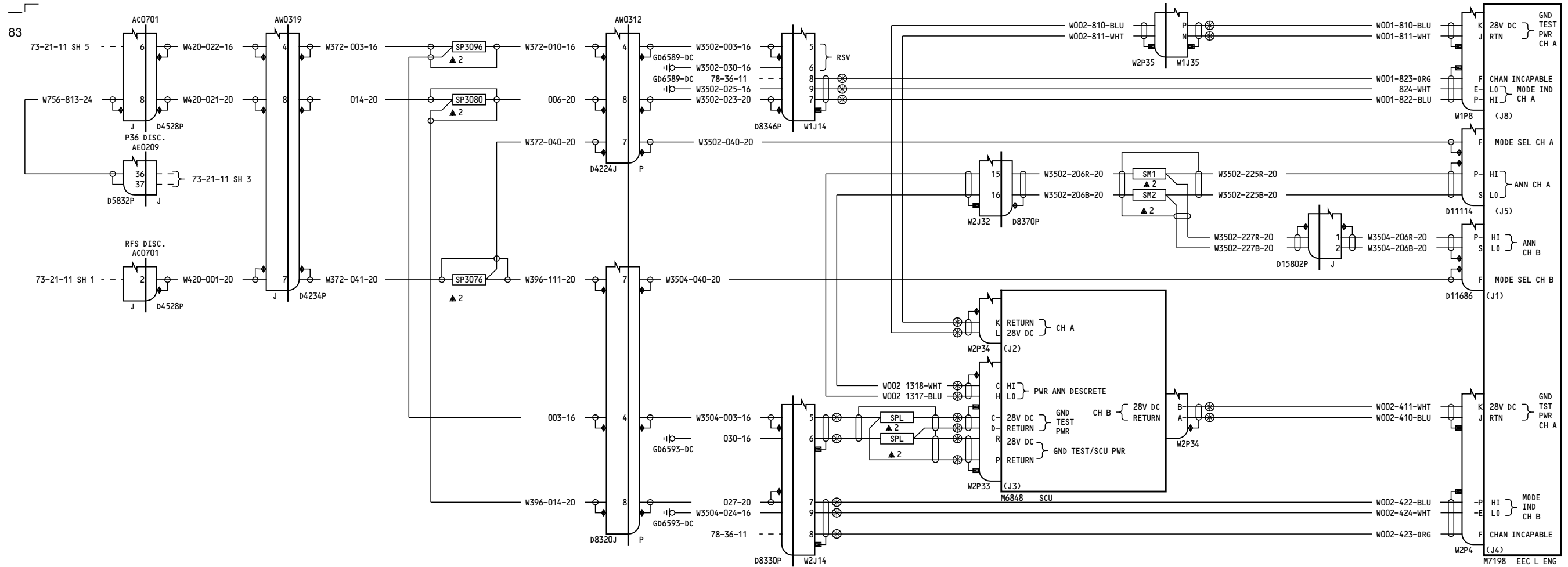

NOTES:
SHIELD PIGTAIL TO DISCONNECT BACKSHELL 2 INCH MAXIMUM

150-154

ELECTRONIC ENGINE CONTROL & INDICATION DISCRETES

D280T132

73-21-11

Page 2.1
Sheet 7
Jan 21/2005

Incorporates
76-0030 R02

73-21-11

Page 2.1
Sheet 7
Jan 21/2005

-A
56

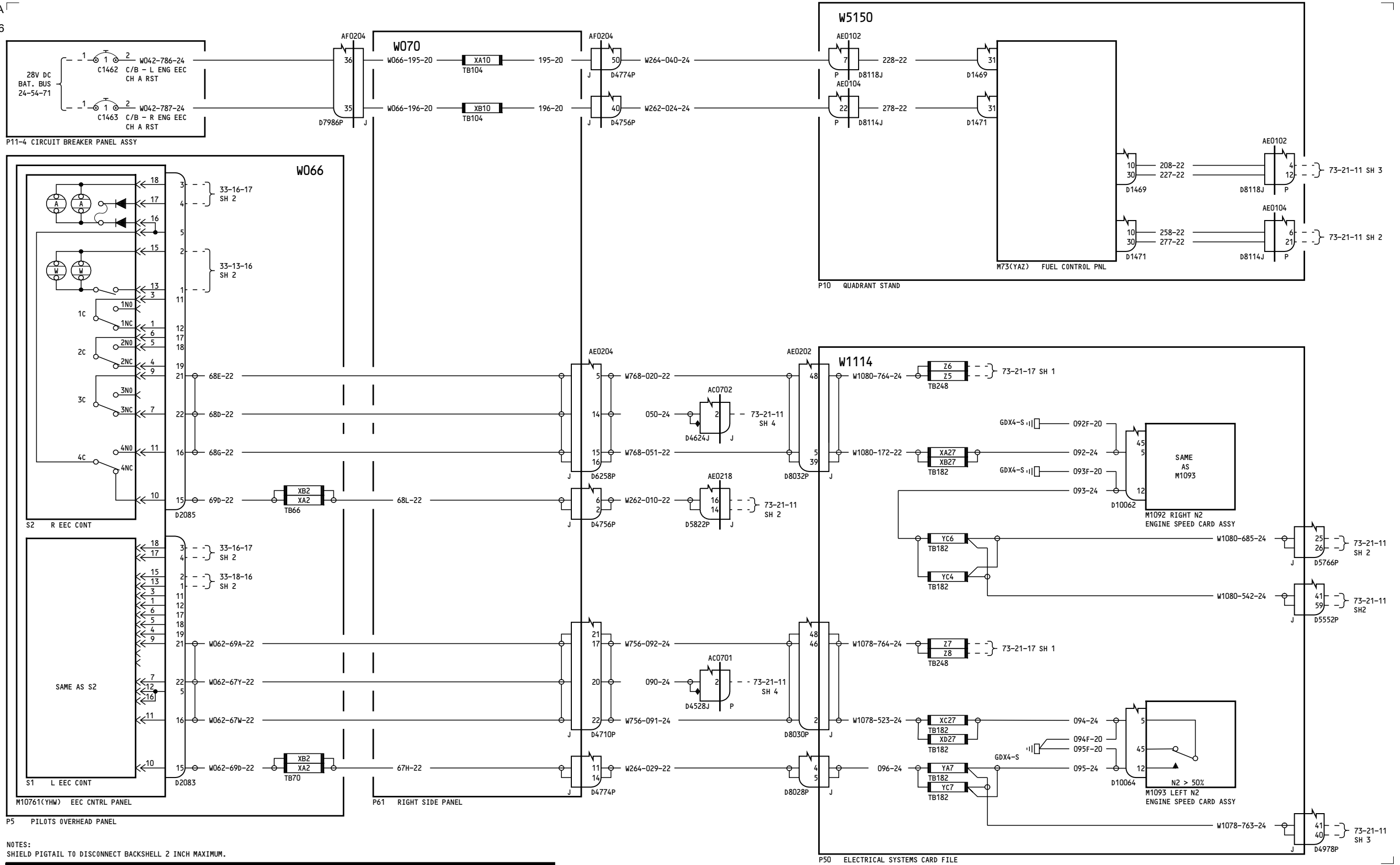

NOTES:
SHIELD PIGTAIL TO DISCONNECT BACKSHELL 2 INCH MAXIMUM.

155-199

ELECTRONIC ENGINE CONTROL & INDICATION DISCRETIVES

D280T132

73-21-11

Page 3
Sheet 1
Jan 21/2005

73-21-11

Page 3
Sheet 1
Jan 21/2005

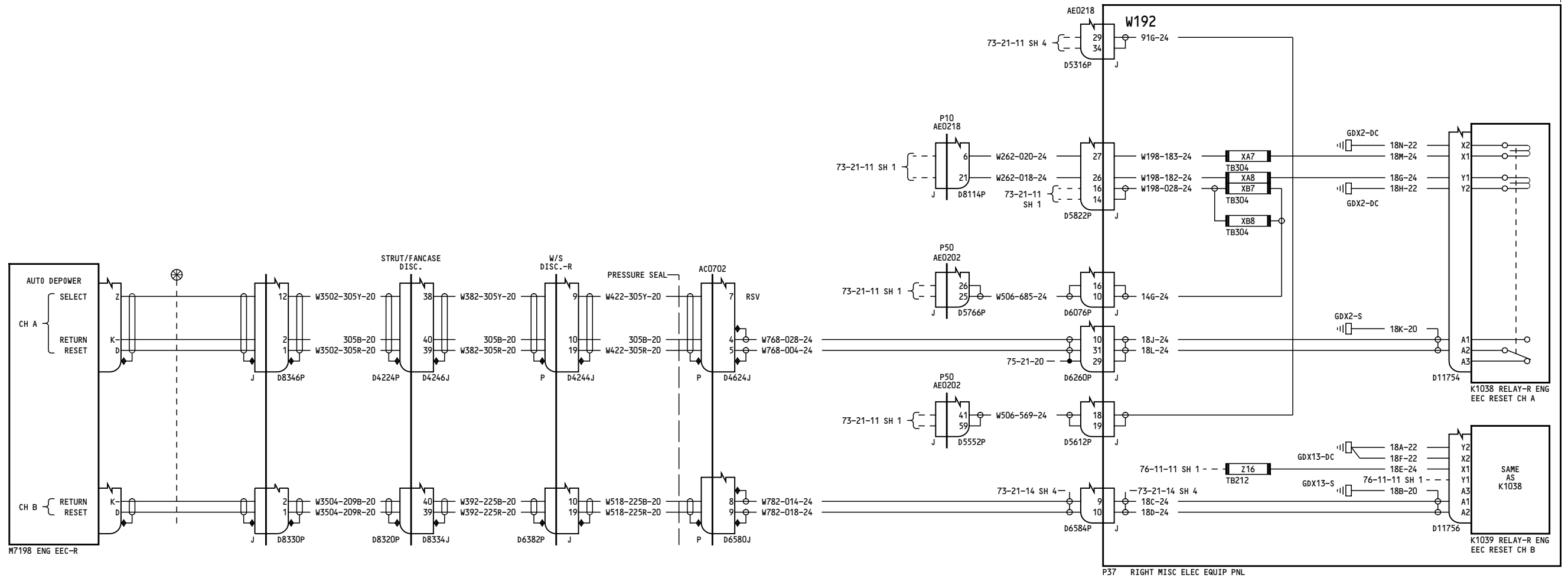

NOTES:
SHIELD PIGTAIL TO DISCONNECT BACKSHELL 2 INCH MAXIMUM

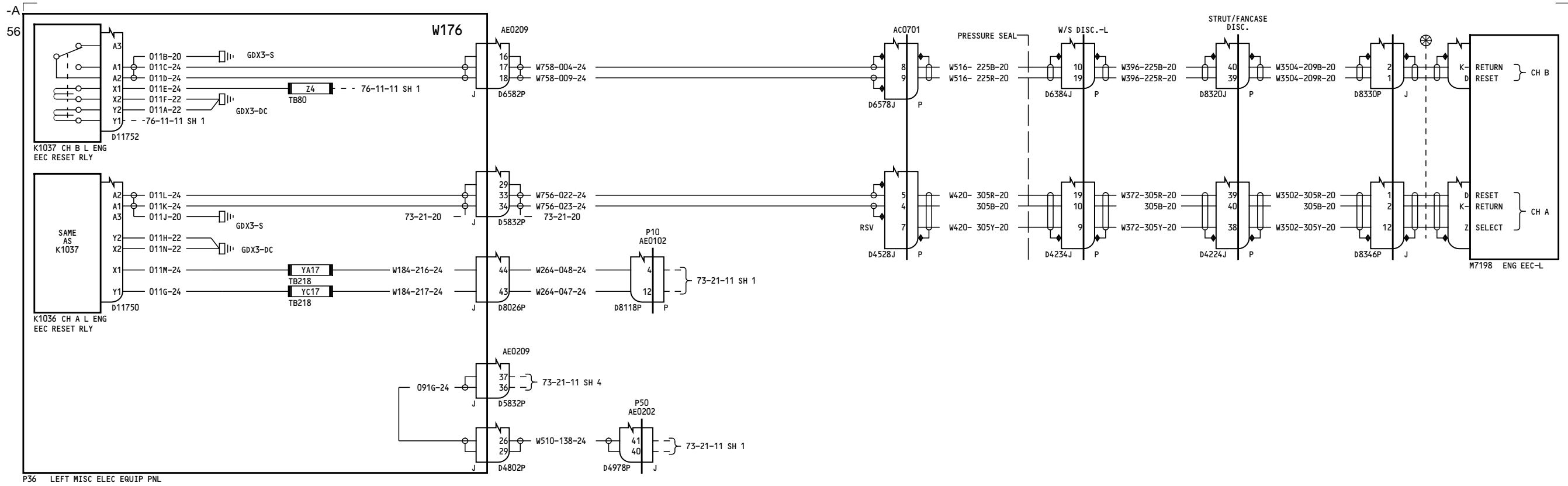

NOTES:
SHIELD PIGTAIL TO DISCONNECT BACKSHELL 2 INCH MAXIMUM

155-199

**ELECTRONIC ENGINE
CONTROL & INDICATION
DISCRETES**

D280T132

73-21-11

Page 3
Sheet 3
Jun 28/2006

73-21-11

Page 3
Sheet 3
Jun 28/2006

-A
56

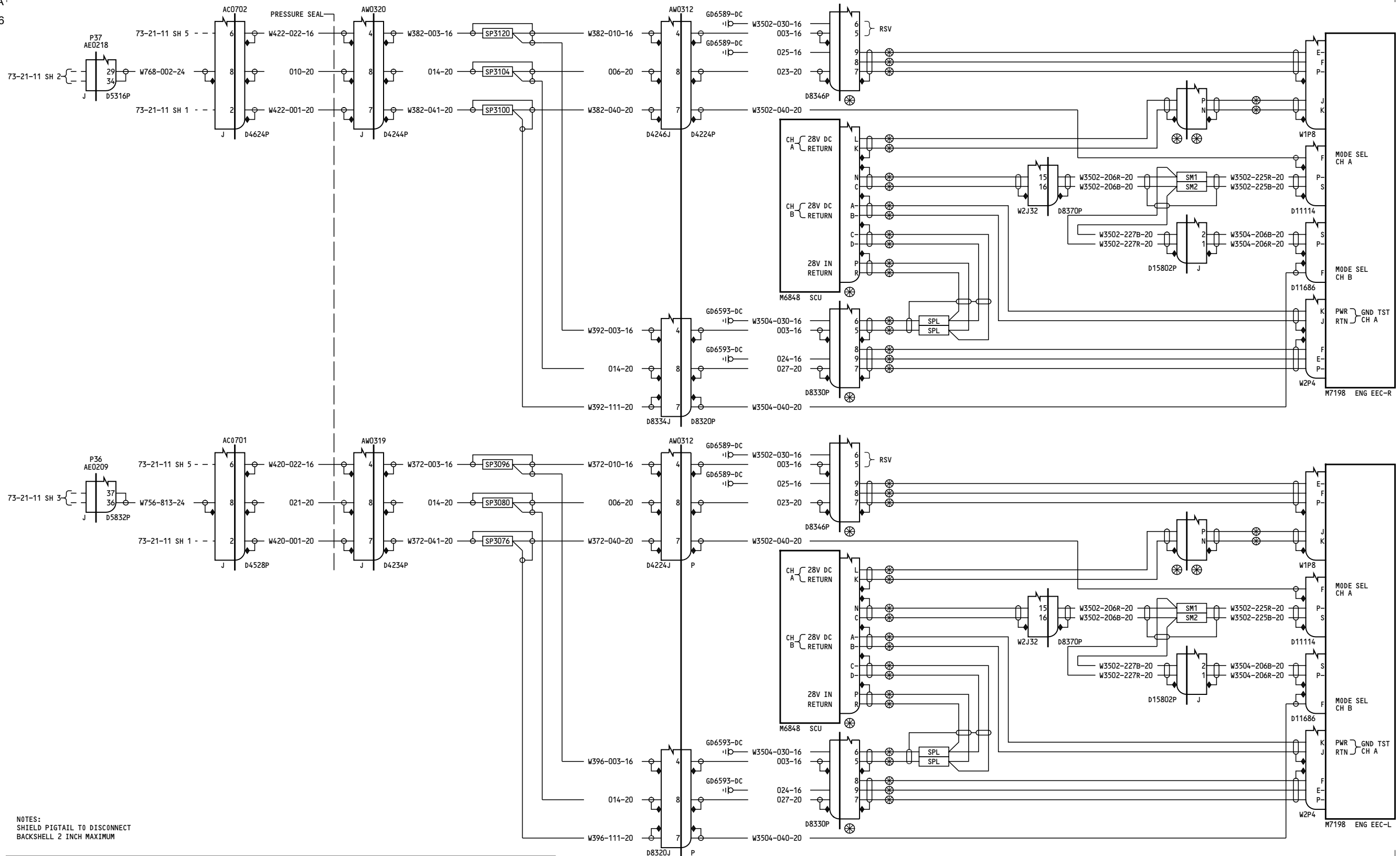

NOTES:
SHIELD PIGTAIL TO DISCONNECT
BACKSHELL 2 INCH MAXIMUM

155-199

**ELECTRONIC ENGINE
CONTROL & INDICATION
DISCRETES**

D280T132

73-21-11

Page 3
Sheet 4
Mar 14/2007

73-21-11

Page 3
Sheet 4
Mar 14/2007

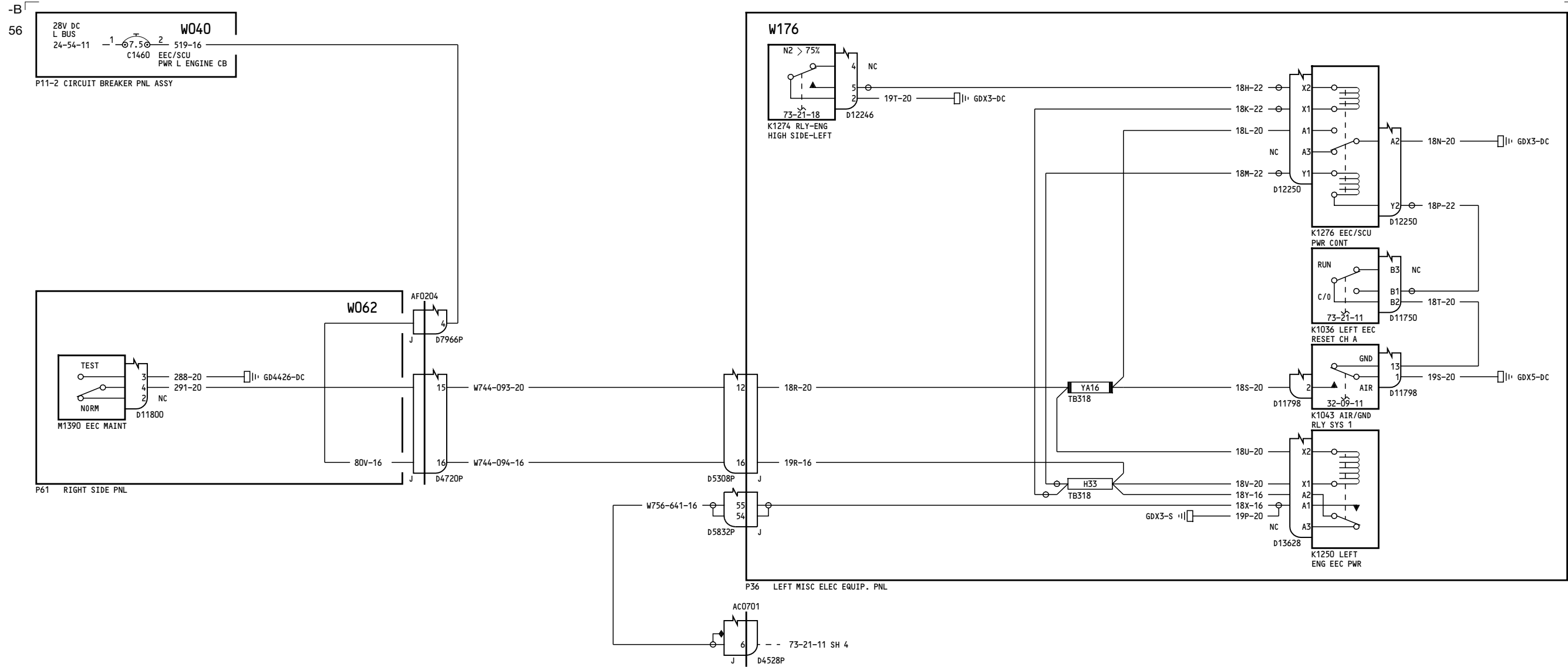

NOTES:
SHIELD PIGTAIL TO DISCONNECT BACKSHELL 2 INCH MAXIMUM

155-199

**ELECTRONIC ENGINE
CONTROL & INDICATION
DISCRETES**

D280T132

73-21-11

Page 3
Sheet 5
Jan 21/2005

73-21-11

Page 3
Sheet 5
Jan 21/2005

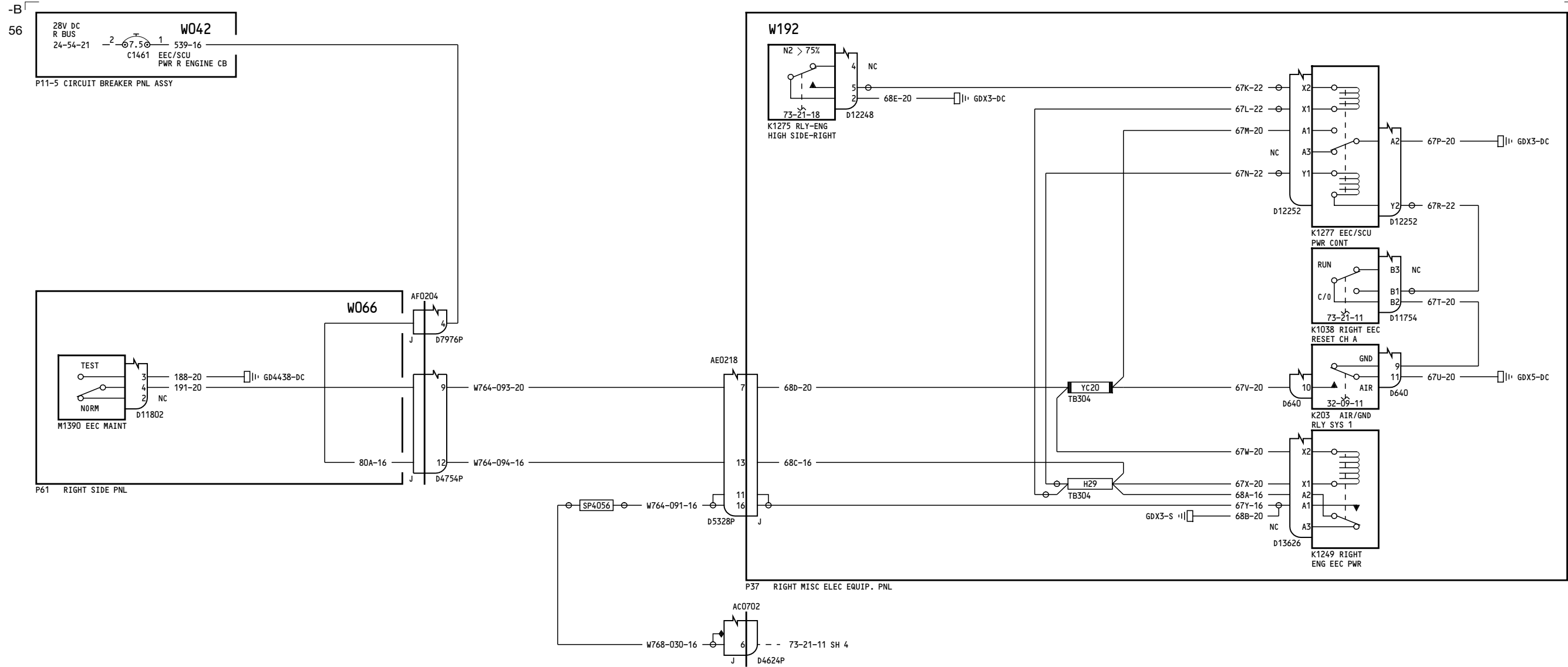

NOTES:
SHIELD PIGTAIL TO DISCONNECT BACKSHELL 2 INCH MAXIMUM

155-199

ELECTRONIC ENGINE CONTROL & INDICATION DISCRETES

D280T132

73-21-11

Page 3
Sheet 6
Jan 21/2005

73-21-11

Page 3
Sheet 6
Jan 21/2005

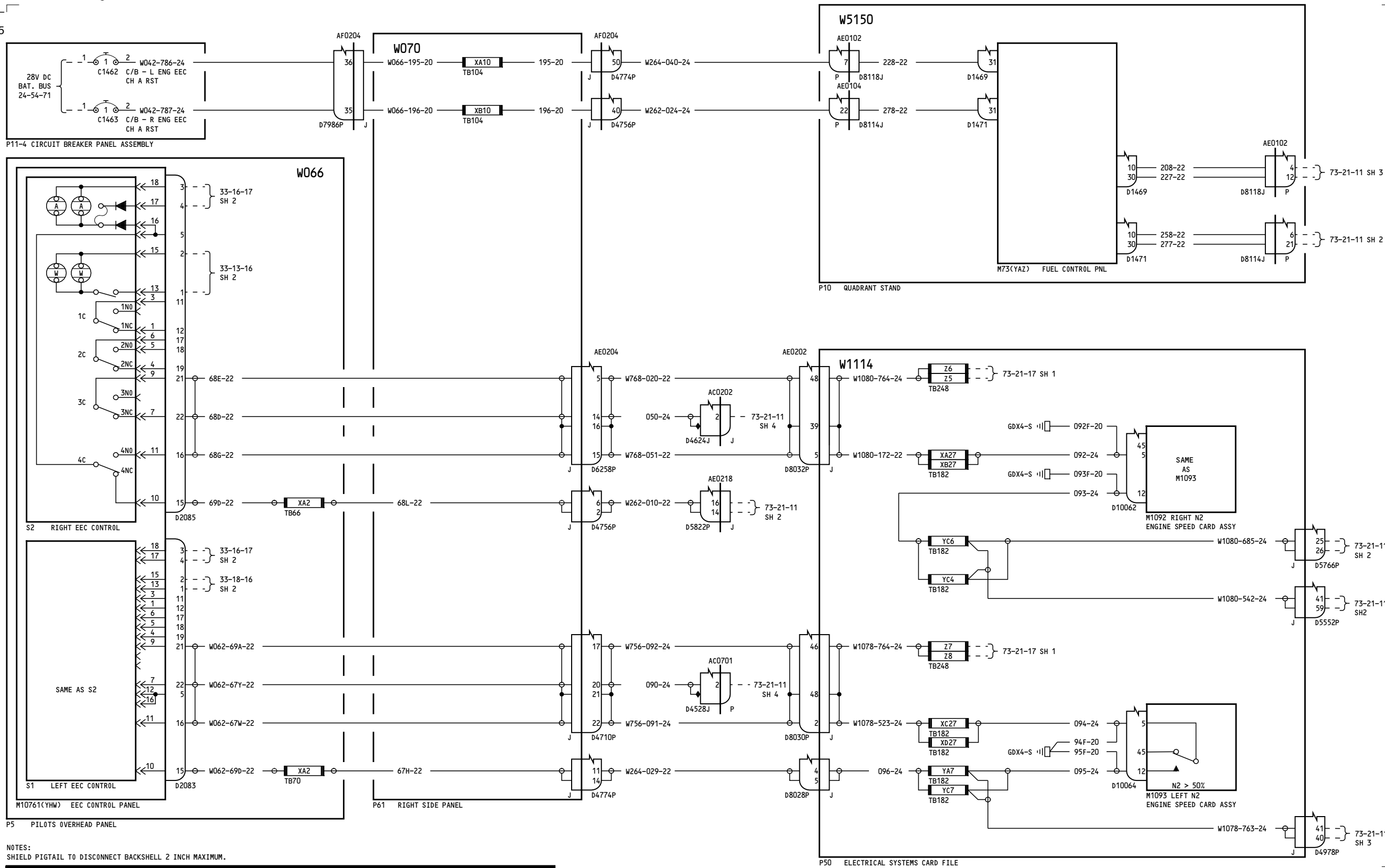

NOTES:
SHIELD PIGTAIL TO DISCONNECT BACKSHELL 2 INCH MAXIMUM.

275-276

ELECTRONIC ENGINE CONTROL & INDICATION DISCRETIVES

D280T132

73-21-11

Page 4.1
Sheet 1
Jan 21/2005

Incorporates
76-0026

73-21-11

Page 4.1
Sheet 1
Jan 21/2005

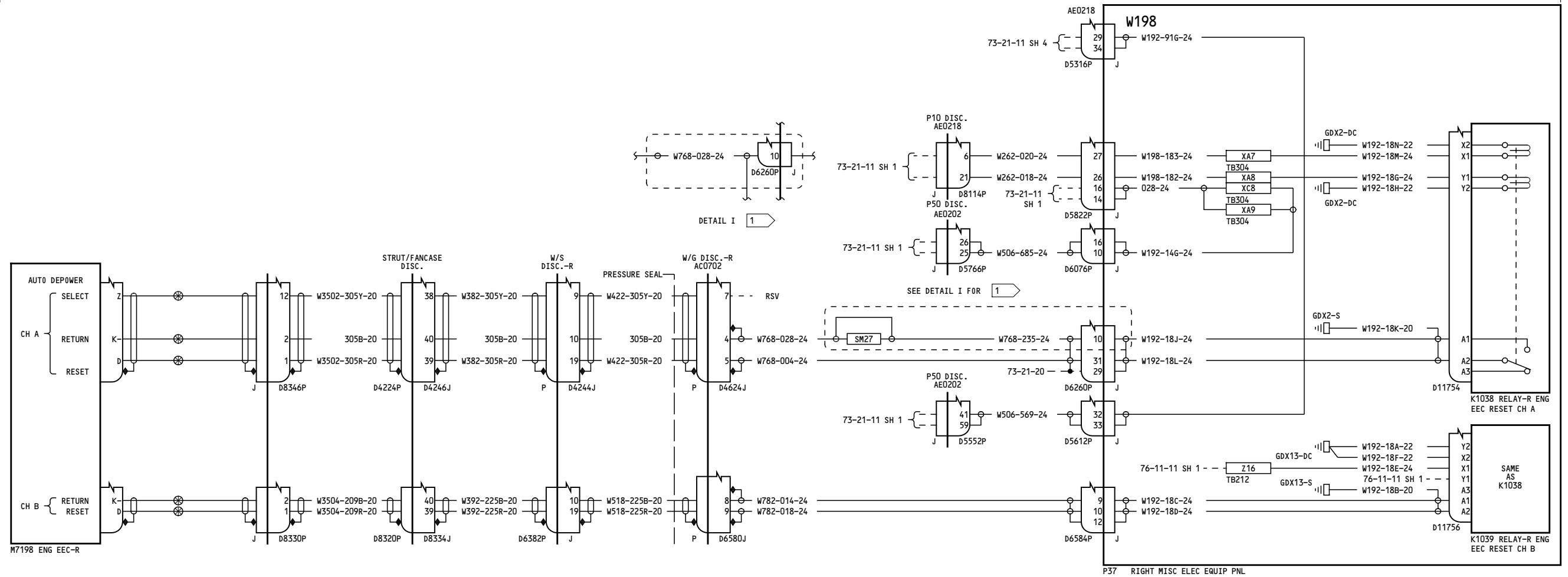

NOTES:
SHIELD PIGTAIL TO DISCONNECT BACKSHELL 2 INCH MAXIMUM

1 VN222-VN222

275-276

ELECTRONIC ENGINE CONTROL & INDICATION DISCRETES

D280T132

73-21-11

Page 4.1
Sheet 2
Jun 28/2006

Incorporates
76-0026

73-21-11

Page 4.1
Sheet 2
Jun 28/2006

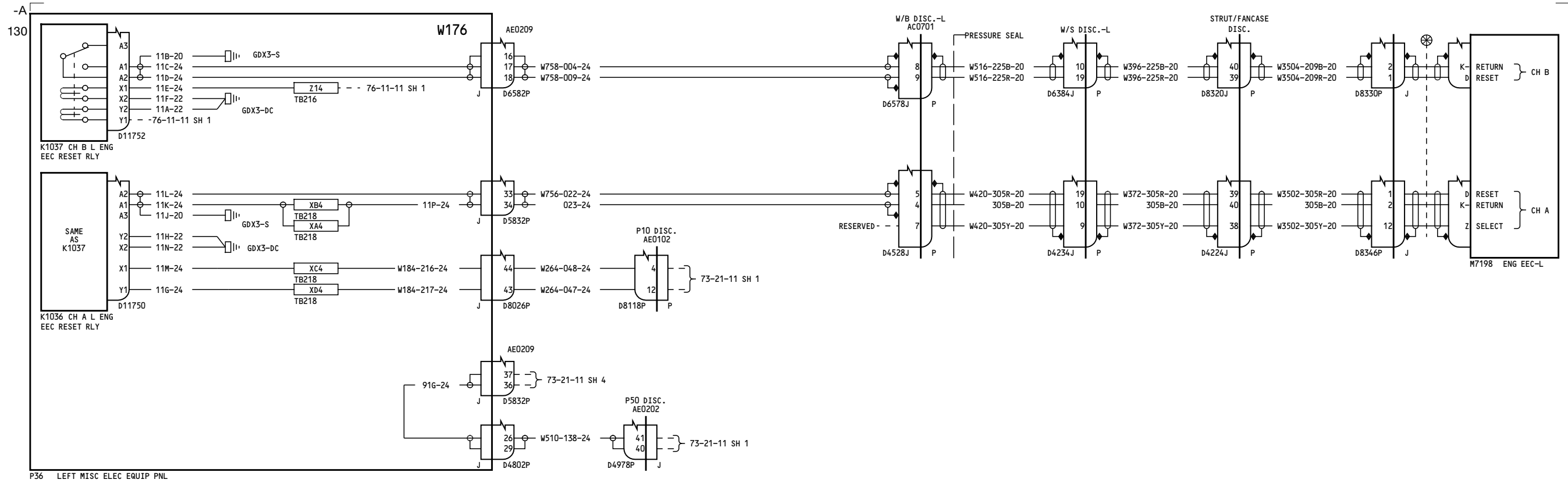

NOTES:
SHIELD PIGTAIL TO DISCONNECT BACKSHELL 2 INCH MAXIMUM

275-276

ELECTRONIC ENGINE CONTROL & INDICATION DISCRETES

D280T132

73-21-11

Page 4.1
Sheet 3
Jun 28/2006

Incorporates
76-0026

73-21-11

Page 4.1
Sheet 3
Jun 28/2006

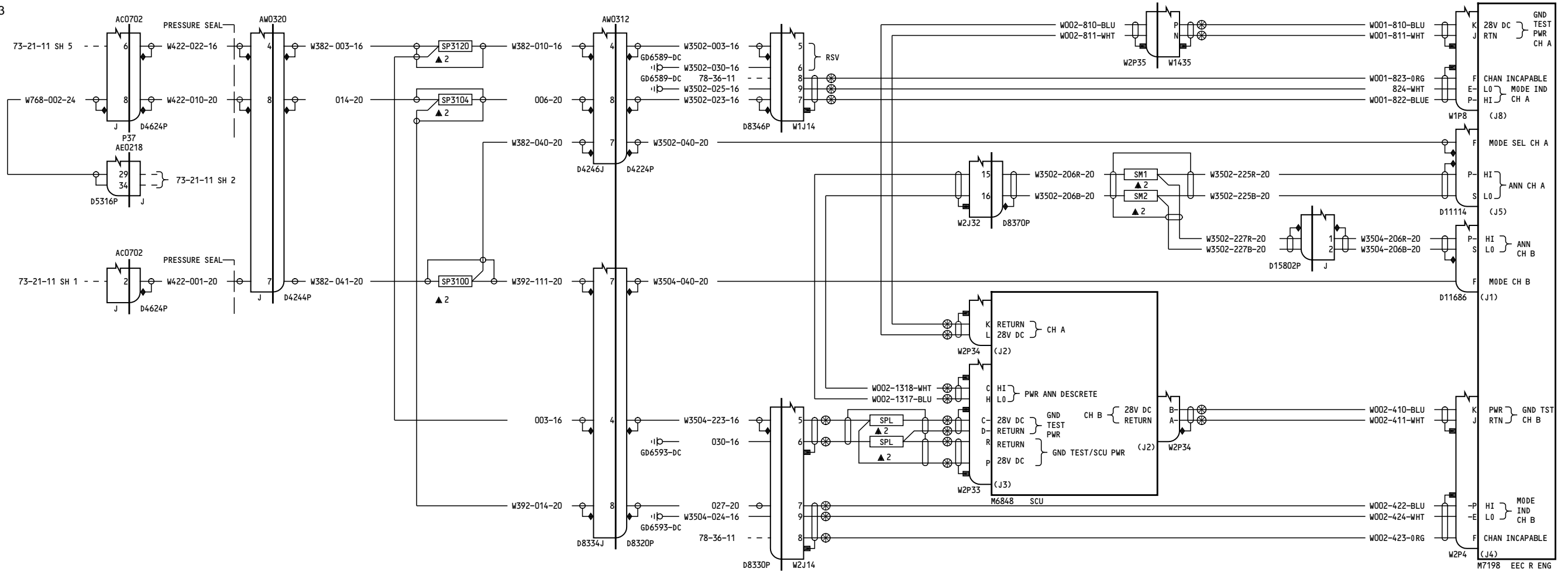

NOTES:
SHIELD PIGTAIL TO DISCONNECT BACKSHELL 2 INCH MAXIMUM

275-276

ELECTRONIC ENGINE CONTROL & INDICATION DISCRETIVES

D280T132

73-21-11

Page 4.1
Sheet 4
Mar 14/2007

Incorporates
76-0026

73-21-11

Page 4.1
Sheet 4
Mar 14/2007

-B

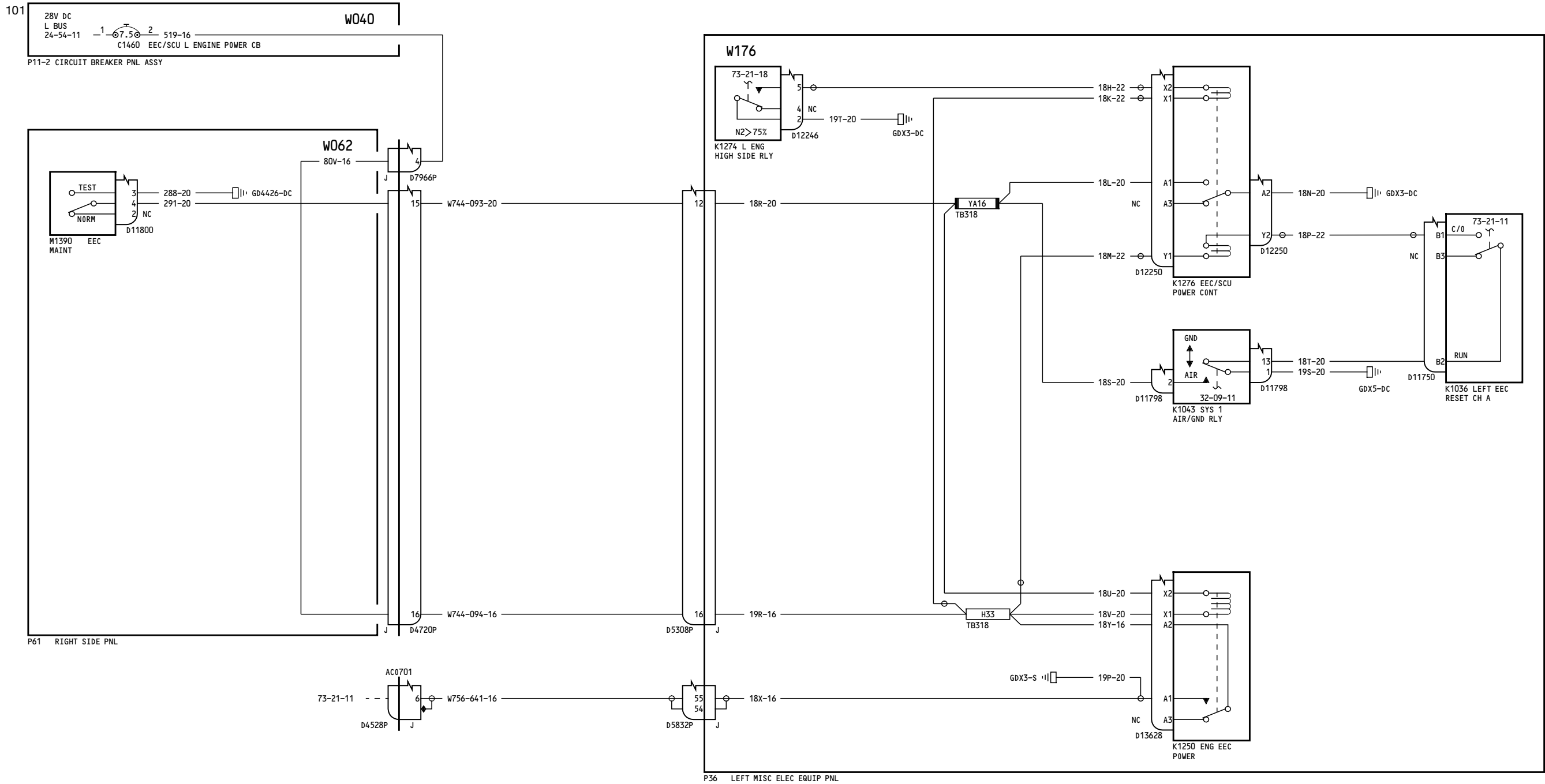

NOTES:
SHEILD PIGTAIL TO DISCONNECT BACKSHELL 2 INCH MAXIMUM

275-276

ELECTRONIC ENGINE CONTROL & INDICATION DISCRETES

D280T132

73-21-11

Page 4.1
Sheet 5
Jan 21/2005

Incorporates
76-0026

73-21-11

Page 4.1
Sheet 5
Jan 21/2005

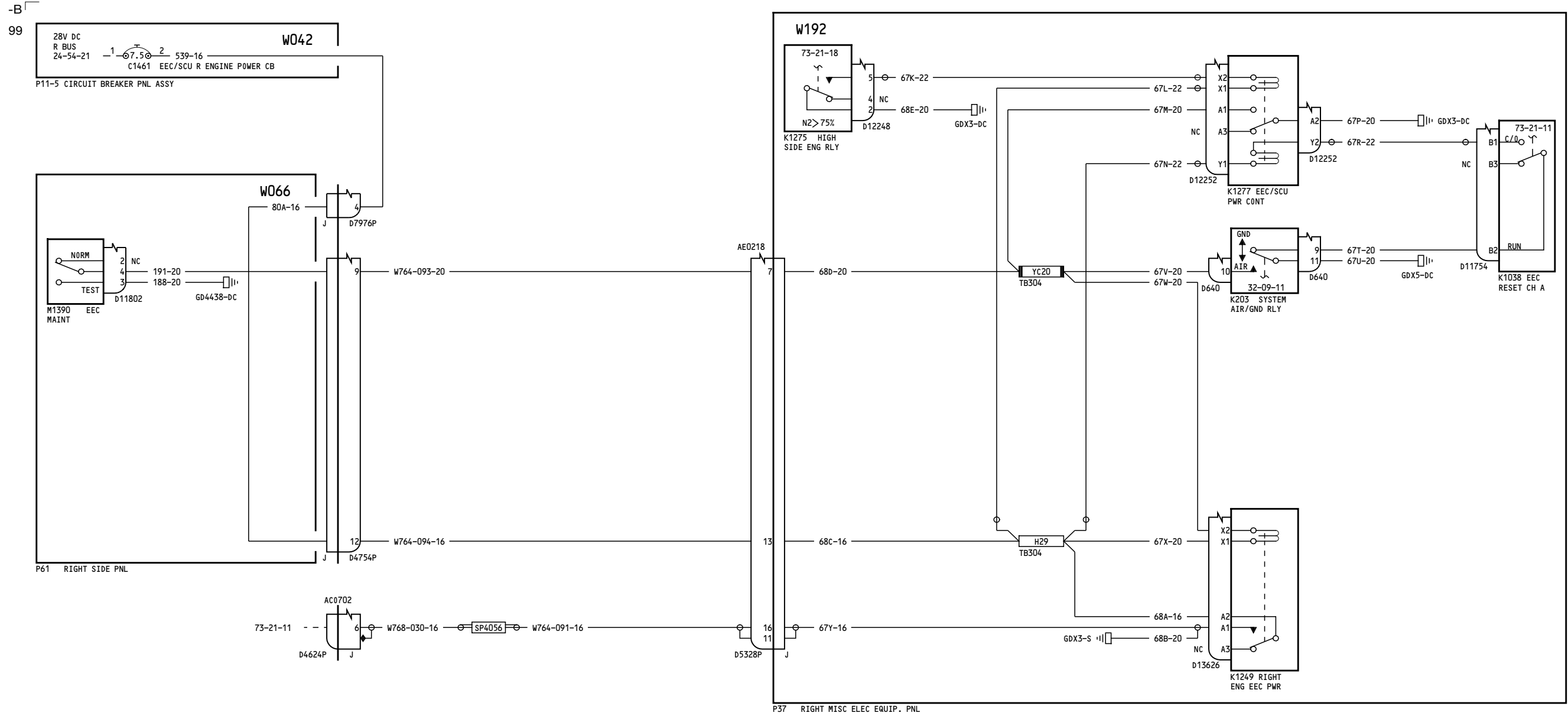

NOTES:
SHIELD PIGTAIL TO DISCONNECT 2 INCH MAXIMUM

275-276

ELECTRONIC ENGINE CONTROL & INDICATION DISCRETES

D280T132

73-21-11

Page 4.1
Sheet 6
Jan 21/2005

Incorporates
76-0026

73-21-11

Page 4.1
Sheet 6
Jan 21/2005

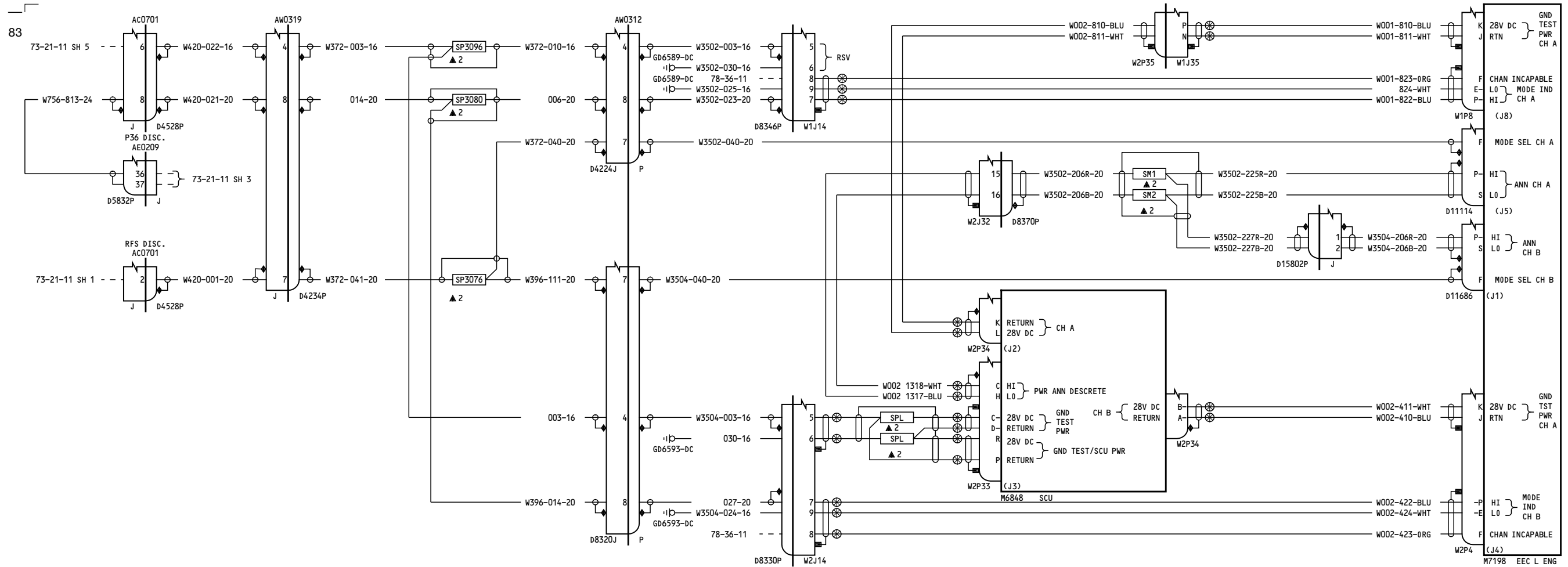

NOTES:
SHIELD PIGTAIL TO DISCONNECT BACKSHELL 2 INCH MAXIMUM

275-276

ELECTRONIC ENGINE CONTROL & INDICATION DISCRETES

D280T132

73-21-11

Page 4.1
Sheet 7
Jan 21/2005

Incorporates
76-0026

73-21-11

Page 4.1
Sheet 7
Jan 21/2005

-B
73

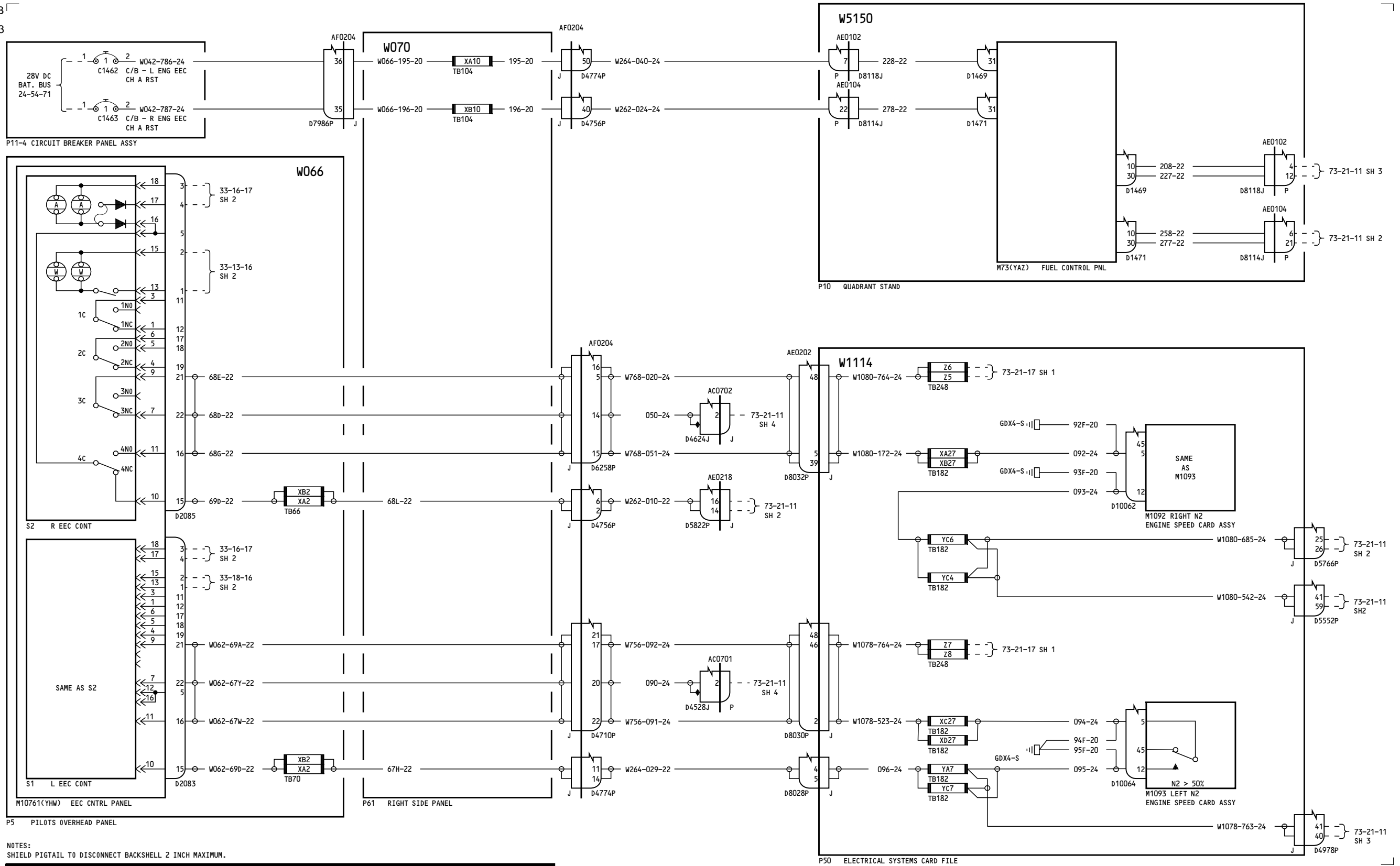

NOTES:
SHIELD PIGTAIL TO DISCONNECT BACKSHELL 2 INCH MAXIMUM.

277-299

ELECTRONIC ENGINE CONTROL & INDICATION DISCRETIVES

D280T132

73-21-11

Page 5
Sheet 1
Jan 21/2005

73-21-11

Page 5
Sheet 1
Jan 21/2005

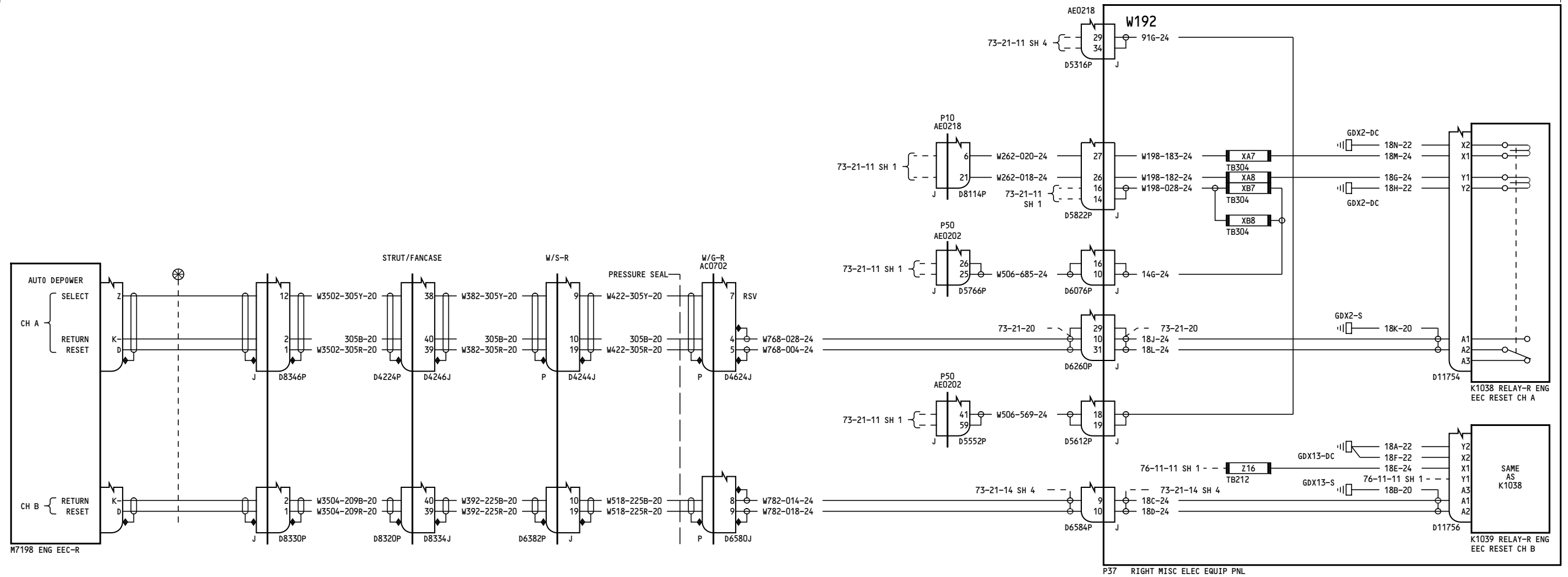

NOTES:
SHIELD PIGTAIL TO DISCONNECT BACKSHELL 2 INCH MAXIMUM.

277-299

ELECTRONIC ENGINE CONTROL & INDICATION DISCRETES

D280T132

73-21-11

Page 5
Sheet 2
Jun 28/2006

73-21-11

Page 5
Sheet 2
Jun 28/2006

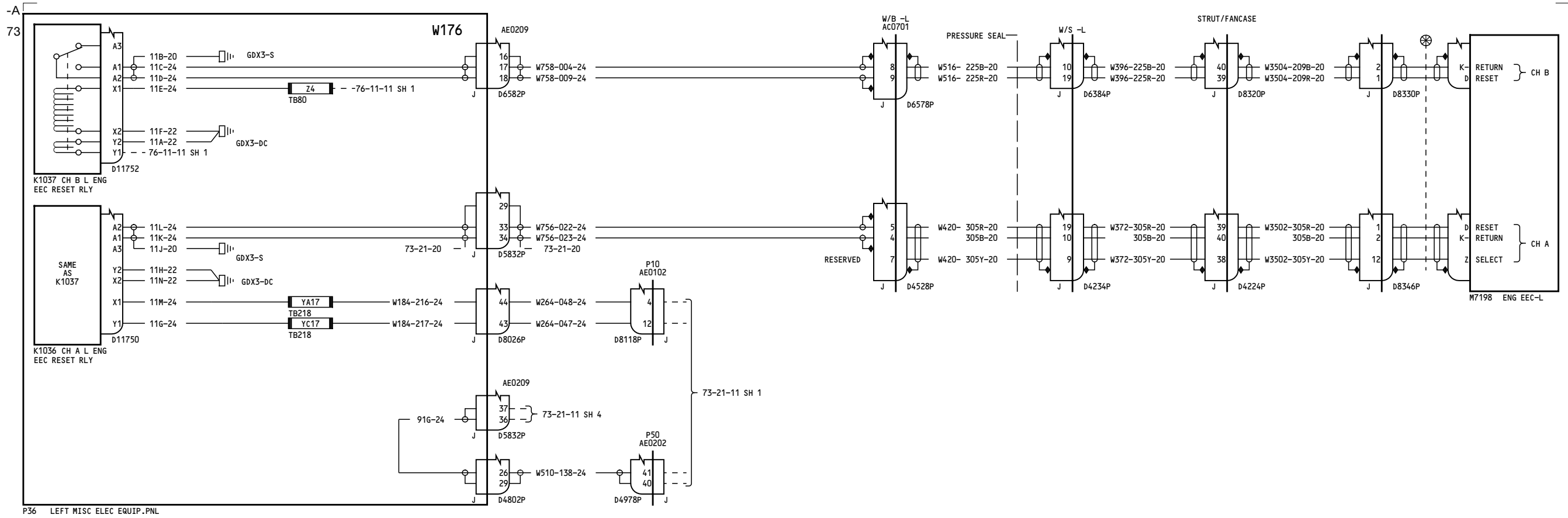

P36 LEFT MISC ELEC EQUIP .PNL

NOTES:
SHIELD PIGTAIL TO DISCONNECT BACKSHELL 2 INCH MAXIMUM.

277-299

ELECTRONIC ENGINE CONTROL & INDICATION DISCRETES

D280T132

73-21-11

Page 5
Sheet 3
Jun 28/2006

73-21-11

Page 5
Sheet 3
Jun 28/2006

-B
73

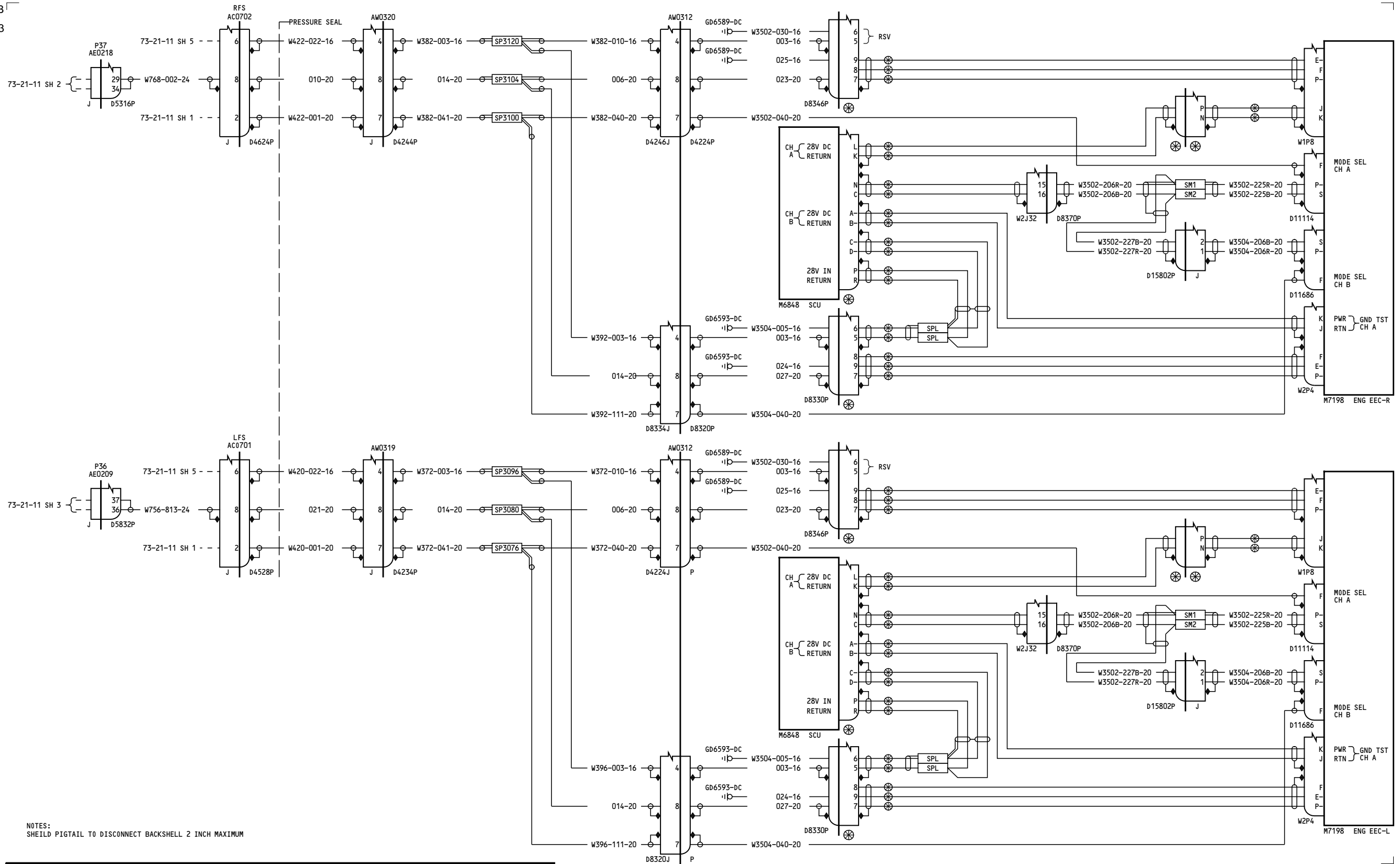

NOTES:
SHIELD PIGTAIL TO DISCONNECT BACKSHELL 2 INCH MAXIMUM

277-299

ELECTRONIC ENGINE CONTROL & INDICATION DISCRETES

D280T132

73-21-11

Page 5
Sheet 4
Mar 14/2007

73-21-11

Page 5
Sheet 4
Mar 14/2007

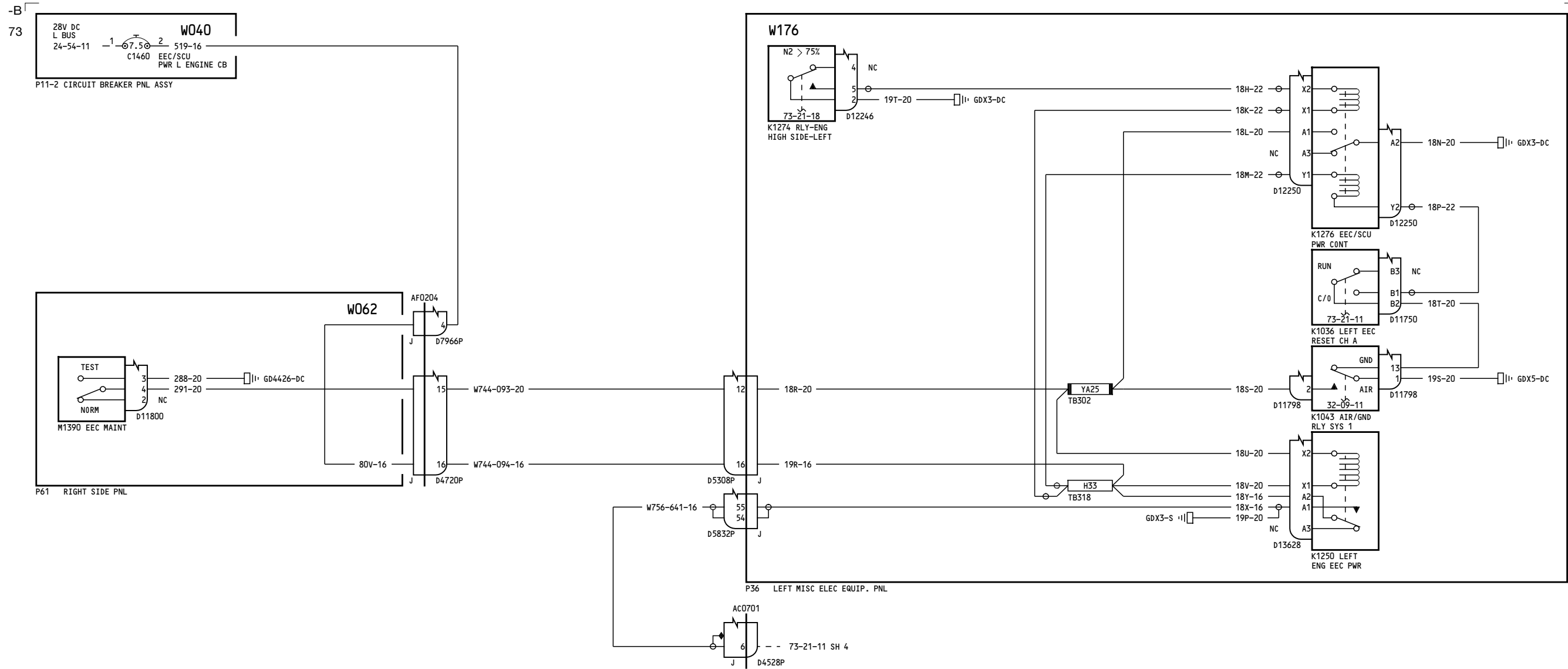

NOTES:
SHEILD PIGTAIL TO DISCONNECT BACKSHELL 2 INCH MAXIMUM.

277-299

ELECTRONIC ENGINE CONTROL & INDICATION DISCRETES

D280T132

73-21-11

Page 5
Sheet 5
Jan 21/2005

73-21-11

Page 5
Sheet 5
Jan 21/2005

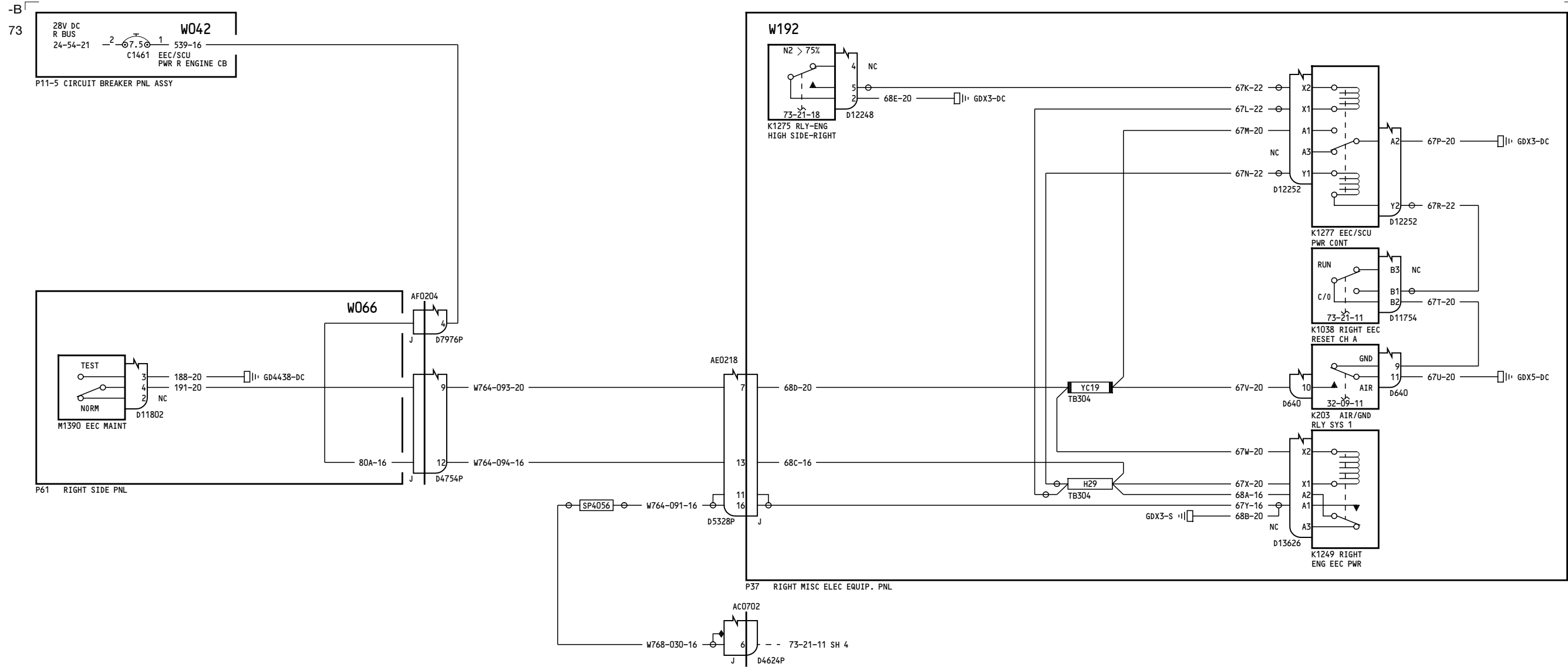

NOTES:
SHEILD PIGTAIL TO DISCONNECT BACKSHELL 2 INCH MAXIMUM.

277-299

ELECTRONIC ENGINE CONTROL & INDICATION DISCRETES

D280T132

73-21-11

Page 5
Sheet 6
Jan 21/2005

73-21-11

Page 5
Sheet 6
Jan 21/2005

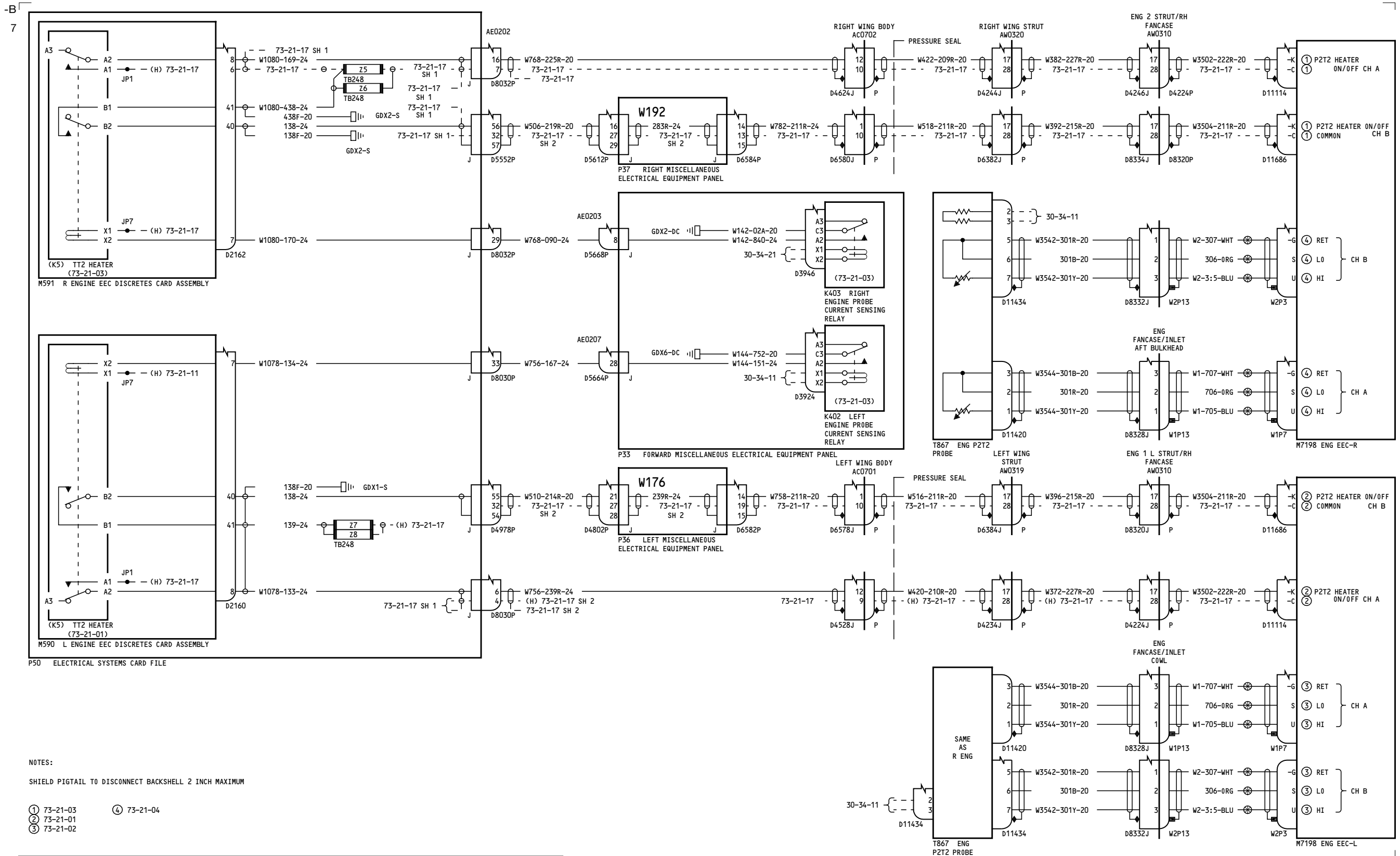

NOTES:
 SHIELD PIGTAIL TO DISCONNECT BACKSHELL 2 INCH MAXIMUM

① 73-21-03 ④ 73-21-04
 ② 73-21-01
 ③ 73-21-02

050-099, 150-199

TT2 ELECTRONIC ENGINE CONTROL DISCRETE

73-21-12

Page 1

D280T132

Jan 21/2005

73-21-12

Page 1

Jan 21/2005

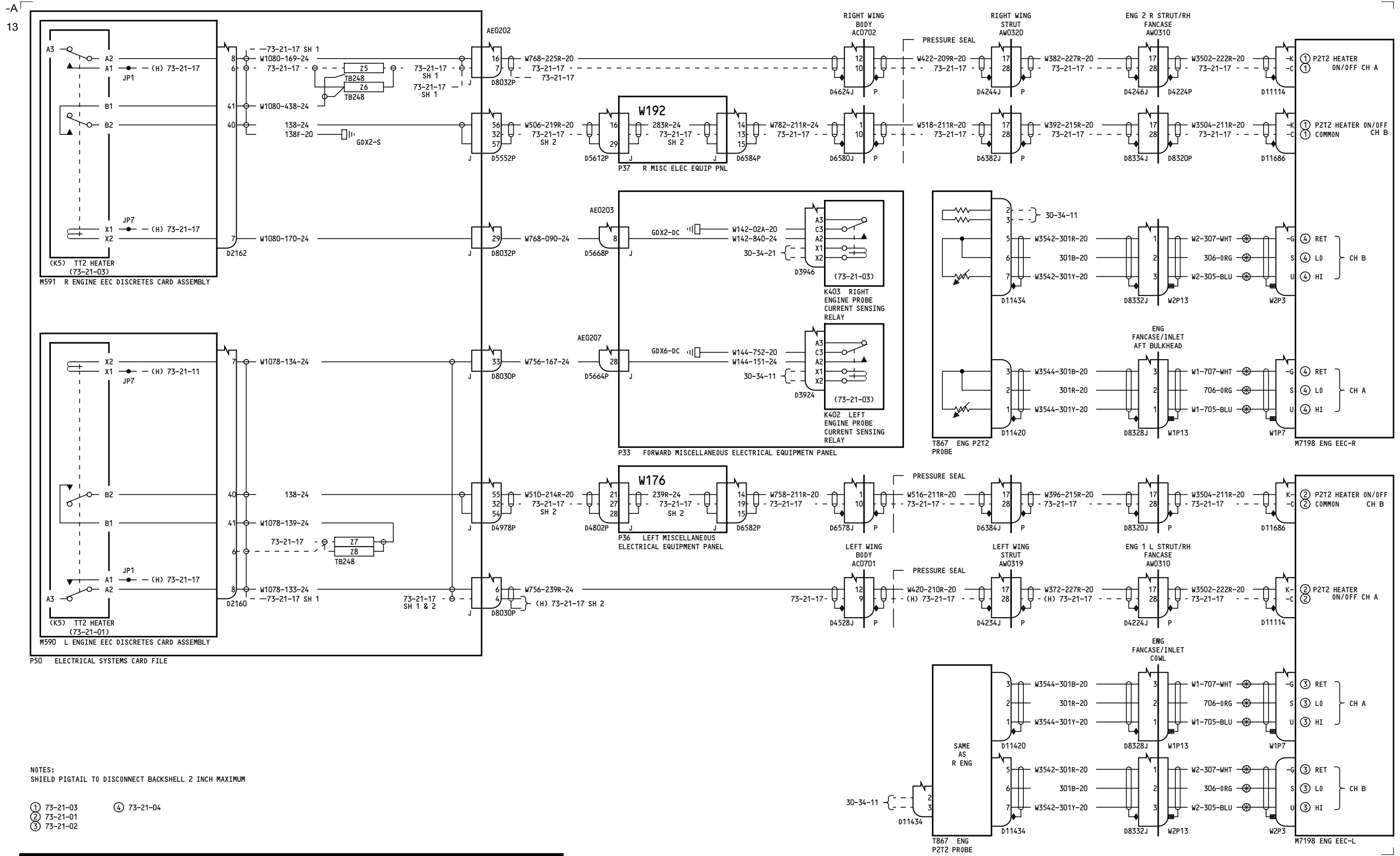

NOTES:
SHIELD PIGTAIL TO DISCONNECT BACKSHELL 2 INCH MAXIMUM

① 73-21-03 ④ 73-21-04
② 73-21-01
③ 73-21-02

275-276	<p>TT2 ELECTRONIC ENGINE CONTROL DISCRETE</p> <p>D280T132</p>
---------	---

73-21-12

Page 2

Jan 21/2005

73-21-12

Page 2

Jan 21/2005

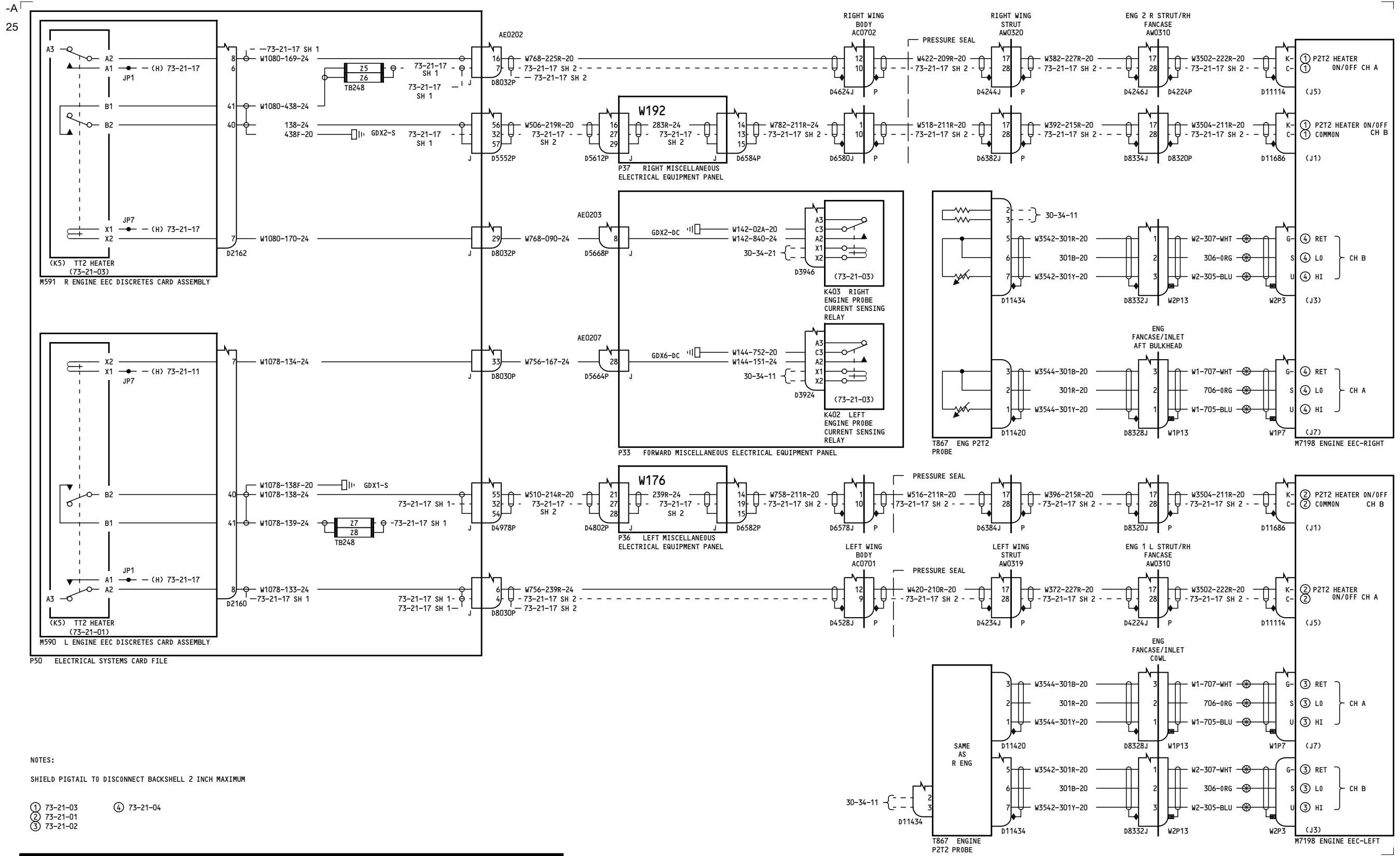

NOTES:
 SHIELD PIGTAIL TO DISCONNECT BACKSHELL 2 INCH MAXIMUM

① 73-21-03 ④ 73-21-04
 ② 73-21-01
 ③ 73-21-02

277-299

TT2 ELECTRONIC ENGINE CONTROL DISCRETE

73-21-12

Page 3

D280T132

Jan 21/2005

73-21-12

Page 3

Jan 21/2005

5

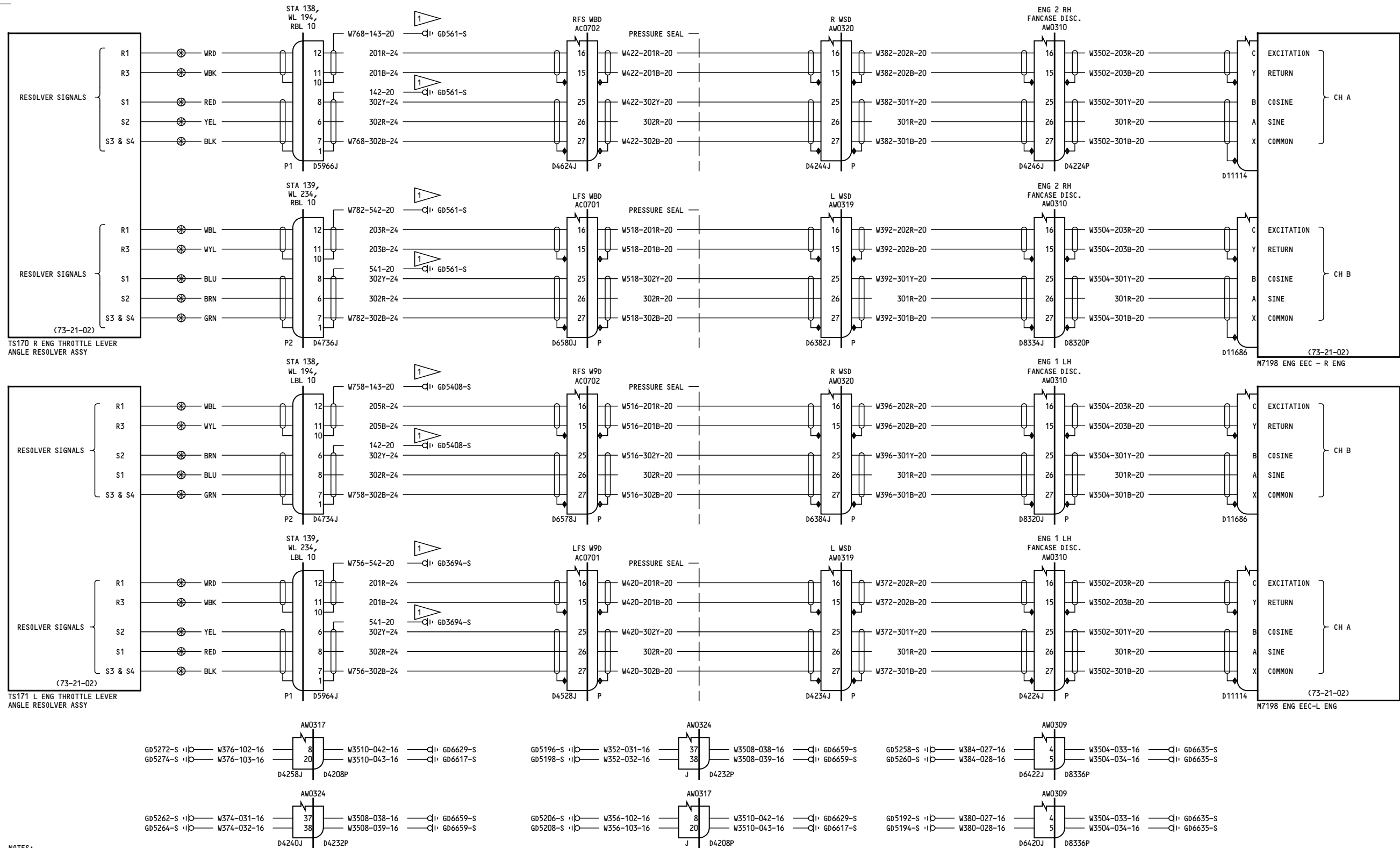

050-099, 150-156, 162-166, 275-278

THROTTLE LEVER ANGLE RESOLVER

73-21-13

Page 1

D280T132

Jan 21/2005

73-21-13

Page 1

Jan 21/2005

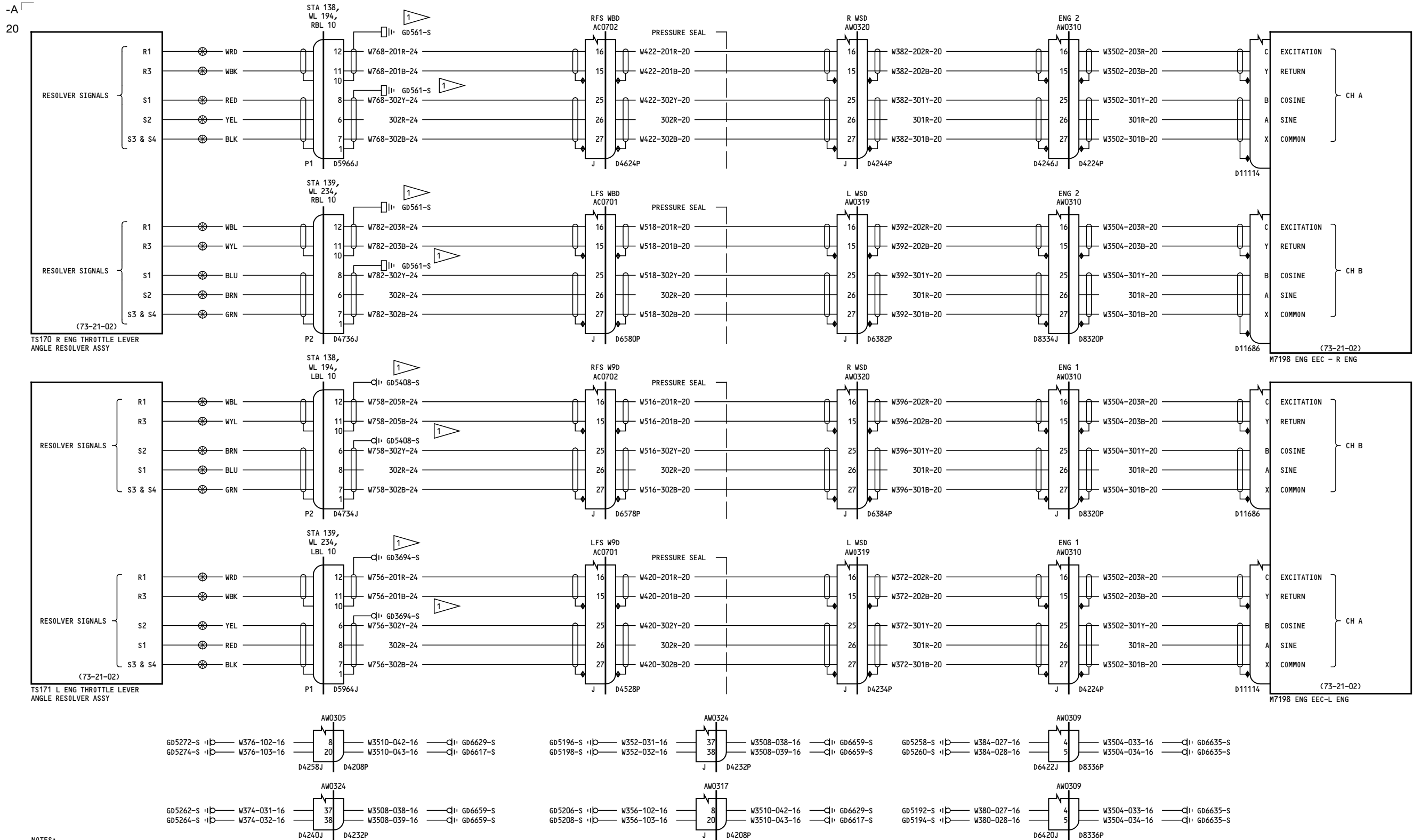

NOTES:
 SHIELD PIGTAIL TO DISCONNECT BACKSHELL 2 INCH MAXIMUM SHIELD GROUND PIGTAILS 6 INCH MAX

157, 167-199, 280-299

THROTTLE LEVER ANGLE RESOLVER

D280T132

73-21-13

Page 2

Jan 21/2005

73-21-13

Page 2

Jan 21/2005

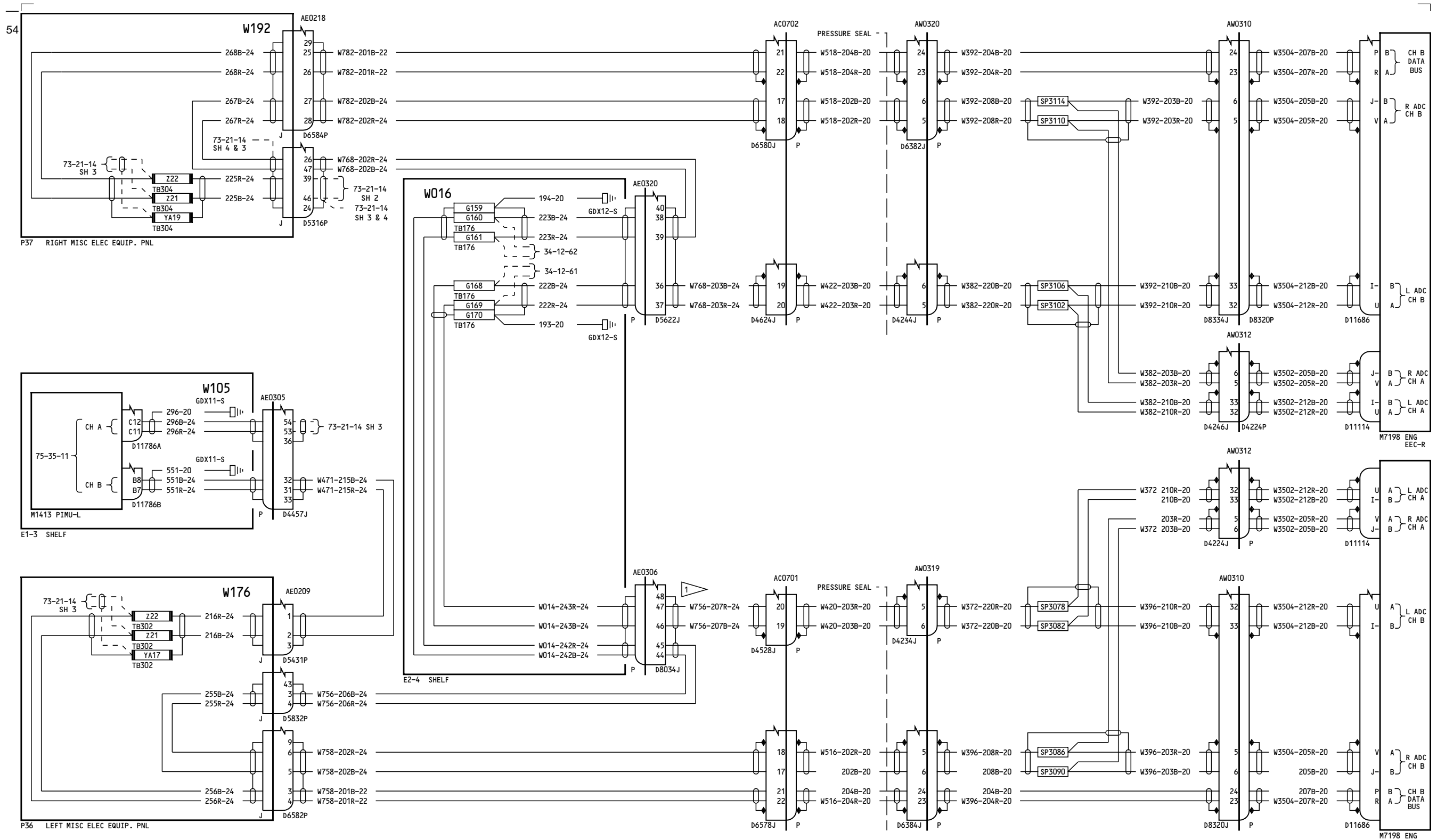

NOTES:
SHIELD PIGTAIL TO DISCONNECT
BACK SHELL 2 INCH MAXIMUM

1 SHIELD GROUND PIGTAIL 6 INCH MAXIMUM

050-051

**ELECTRONIC ENGINE CONTROL
DATA BUSES**

73-21-14

Page 1.1
Sheet 1
Jan 21/2005

D280T132

73-21-14

Page 1.1
Sheet 1
Jan 21/2005

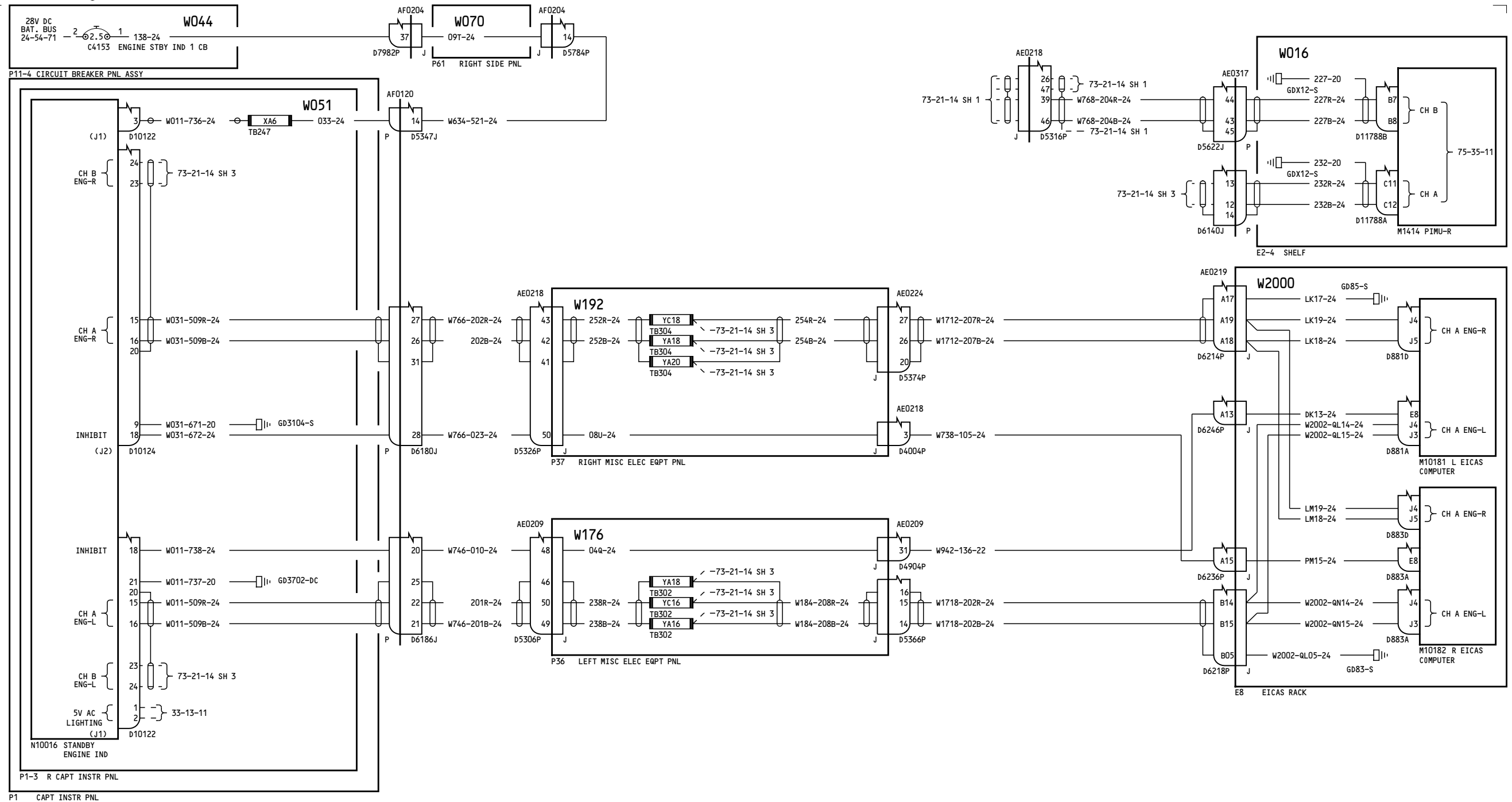

050-051

ELECTRONIC ENGINE CONTROL DATA BUSES

73-21-14

73-21-14

D280T132

Page 1.1
Sheet 2
Jan 21/2005

Page 1.1
Sheet 2
Jan 21/2005

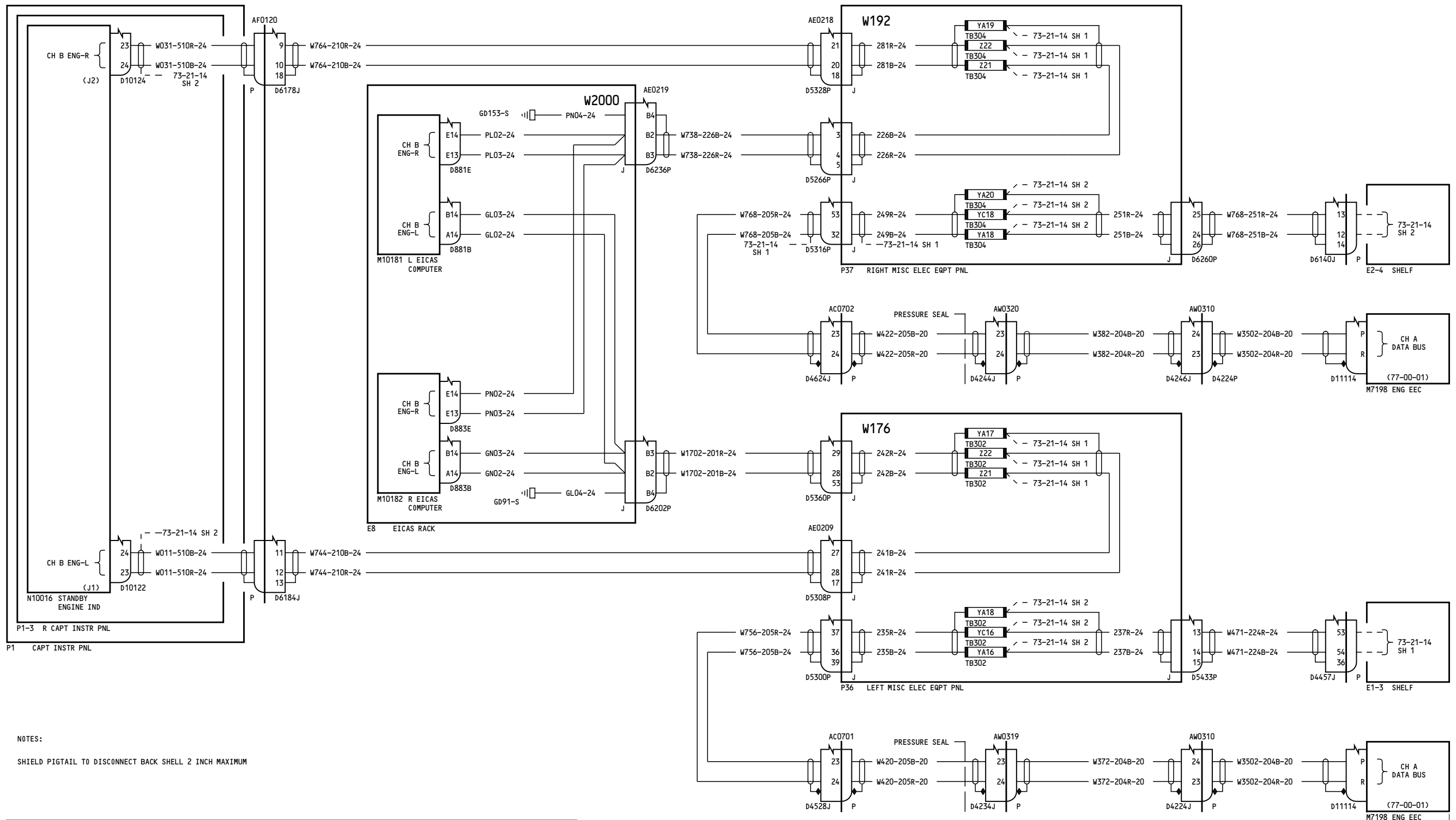

NOTES:
SHIELD PIGTAIL TO DISCONNECT BACK SHELL 2 INCH MAXIMUM

050-051	<p align="center">ELECTRONIC ENGINE CONTROL DATA BUSES</p> <p align="center">D280T132</p>
---------	--

73-21-14

Page 1.1
Sheet 3
Jan 21/2005

Incorporates
73-0036

73-21-14

Page 1.1
Sheet 3
Jan 21/2005

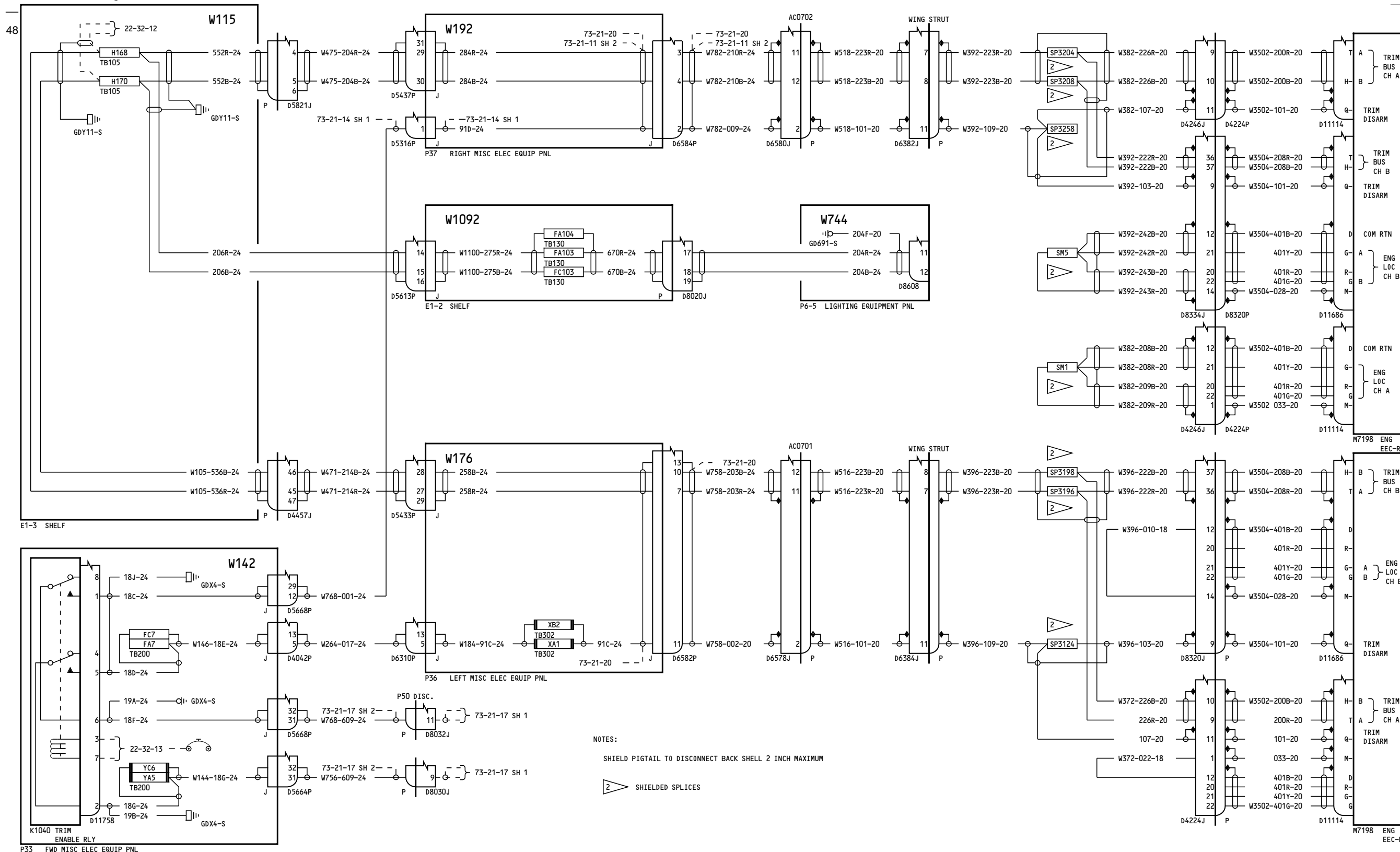

050-051

ELECTRONIC ENGINE CONTROL DATA BUSES

D280T132

73-21-14

73-21-14

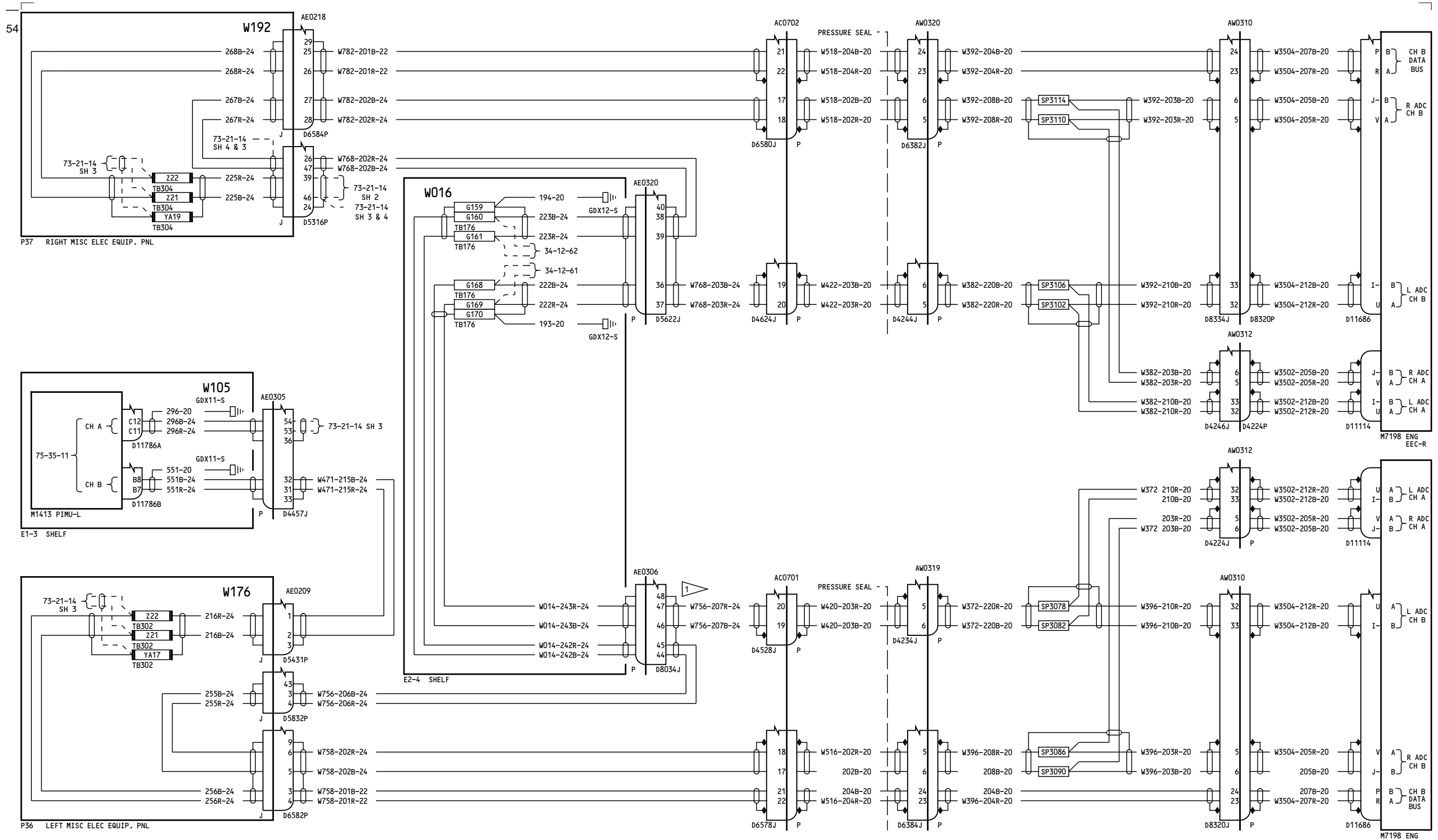

NOTES:
SHIELD PIGTAIL TO DISCONNECT
BACK SHELL 2 INCH MAXIMUM

SHIELD GROUND PIGTAIL 6 INCH MAXIMUM

050

**ELECTRONIC ENGINE CONTROL
DATA BUSES**

73-21-14

Page 1.2
Sheet 1
Jan 21/2005

D280T132

73-21-14

Page 1.2
Sheet 1
Jan 21/2005

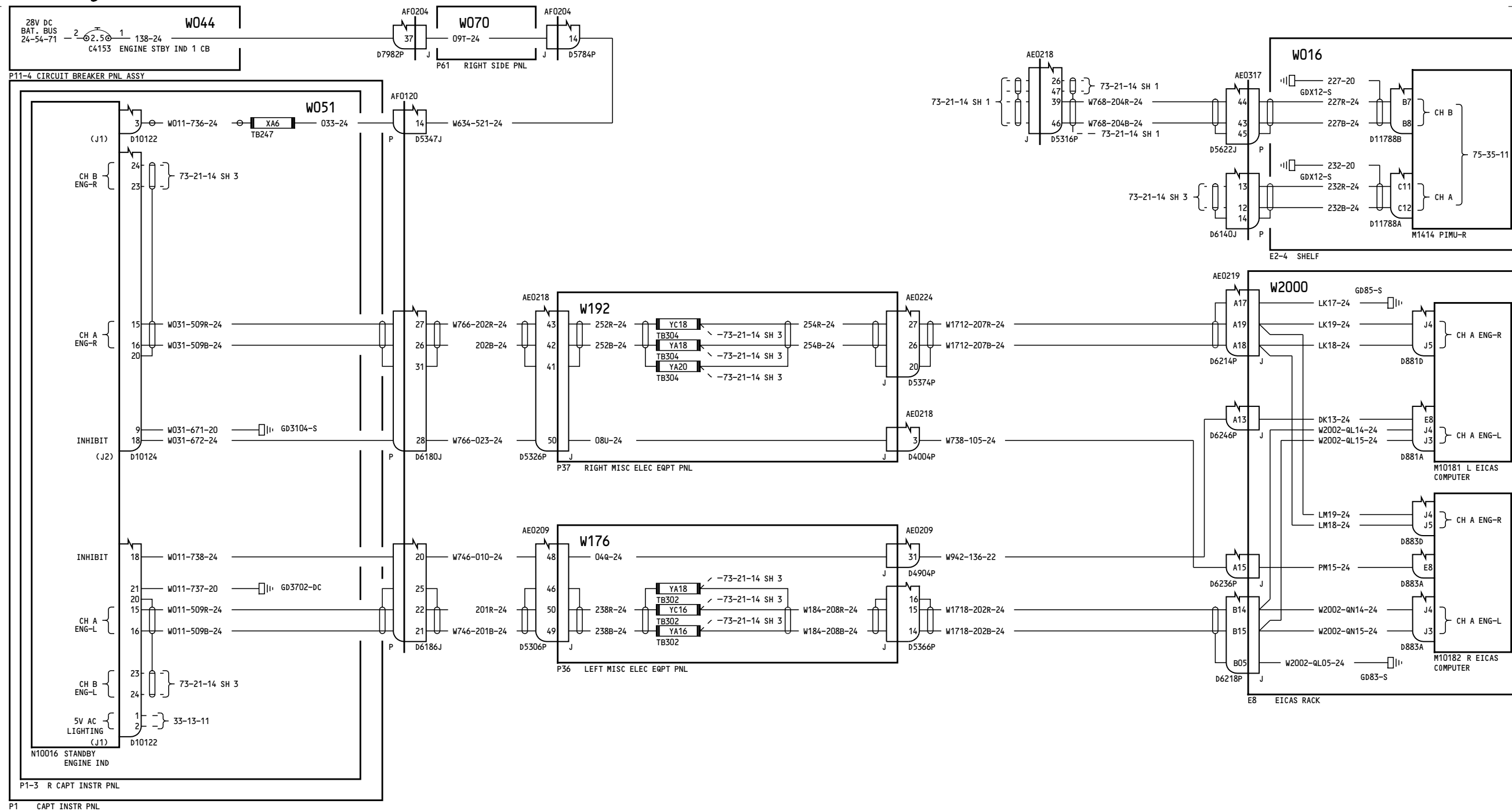

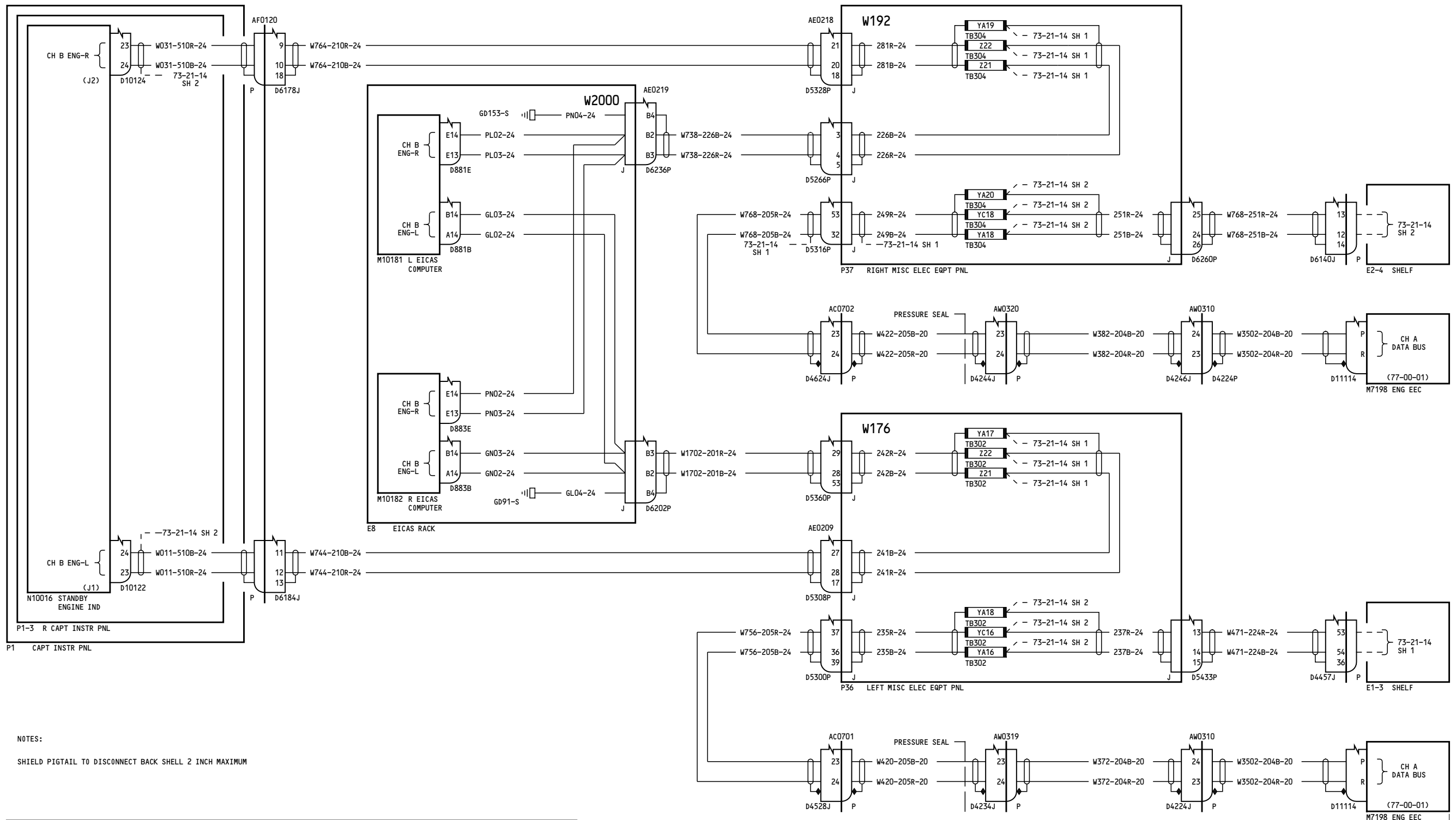

NOTES:
SHIELD PIGTAIL TO DISCONNECT BACK SHELL 2 INCH MAXIMUM

050

ELECTRONIC ENGINE CONTROL DATA BUSES

D280T132

73-21-14

Page 1.2
Sheet 3
Jan 21/2005

Incorporates
73-0036

73-21-14

Page 1.2
Sheet 3
Jan 21/2005

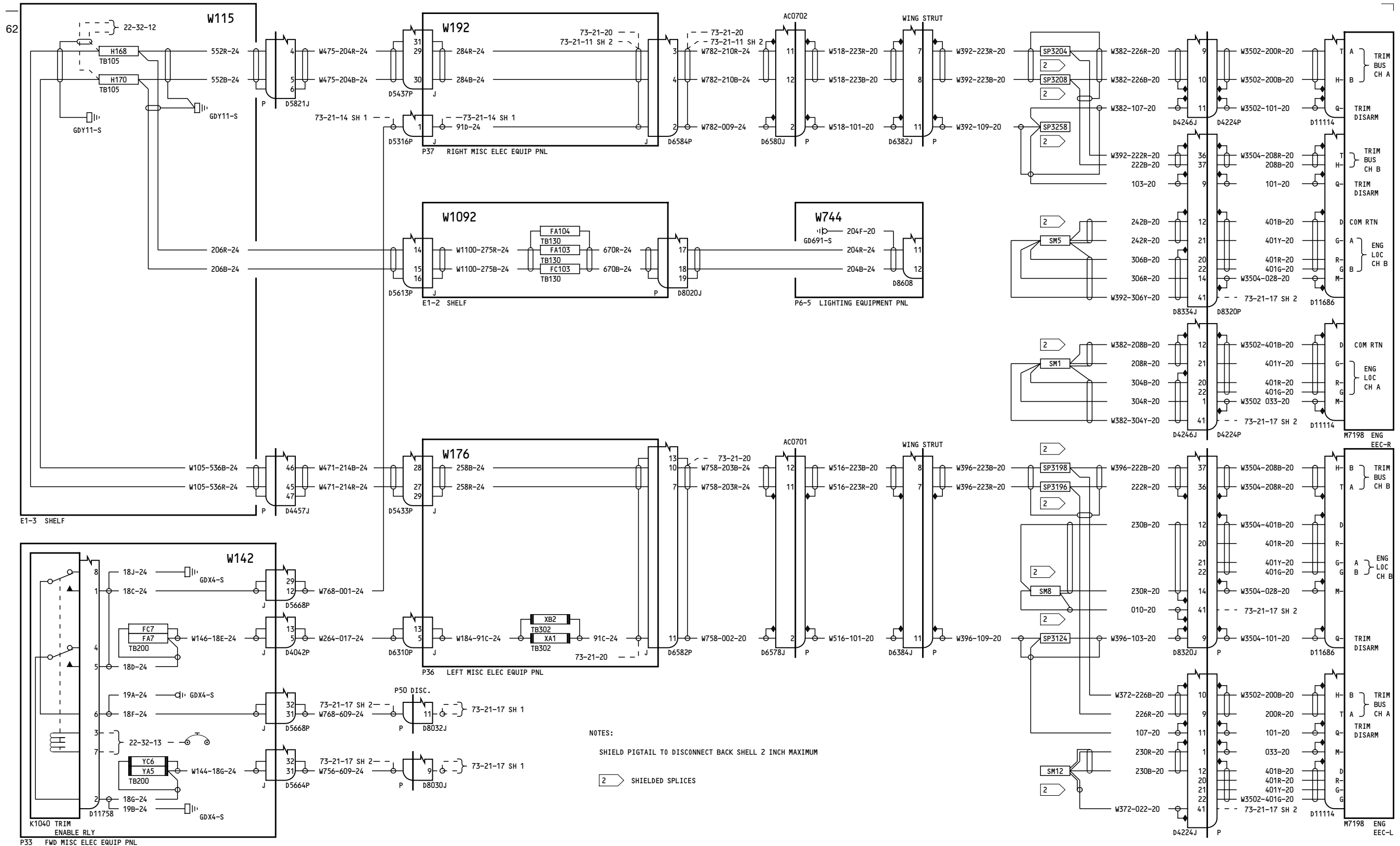

NOTES:
 SHIELD PIGTAIL TO DISCONNECT BACK SHELL 2 INCH MAXIMUM
 [Symbol] SHIELDED SPLICES

050
ELECTRONIC ENGINE CONTROL DATA BUSES
 D280T132

73-21-14
 Page 1.2
 Sheet 4
 Jan 21/2005

Incorporates
 72-0037, 72-0038

73-21-14
 Page 1.2
 Sheet 4
 Jan 21/2005

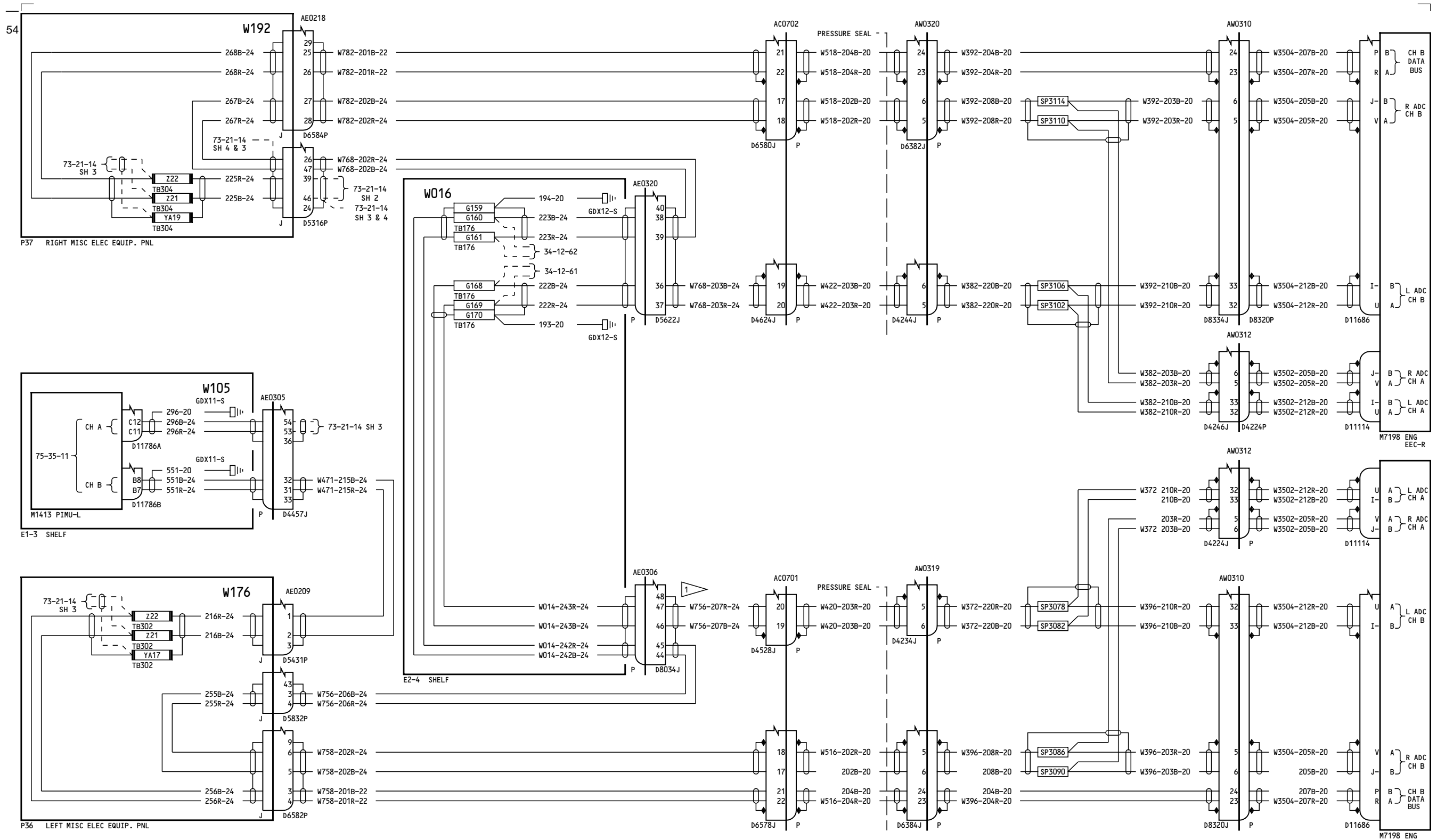

NOTES:
SHIELD PIGTAIL TO DISCONNECT
BACK SHELL 2 INCH MAXIMUM

1 SHIELD GROUND PIGTAIL 6 INCH MAXIMUM

051

**ELECTRONIC ENGINE CONTROL
DATA BUSES**

73-21-14

Page 1.3
Sheet 1
Jan 21/2005

D280T132

73-21-14

Page 1.3
Sheet 1
Jan 21/2005

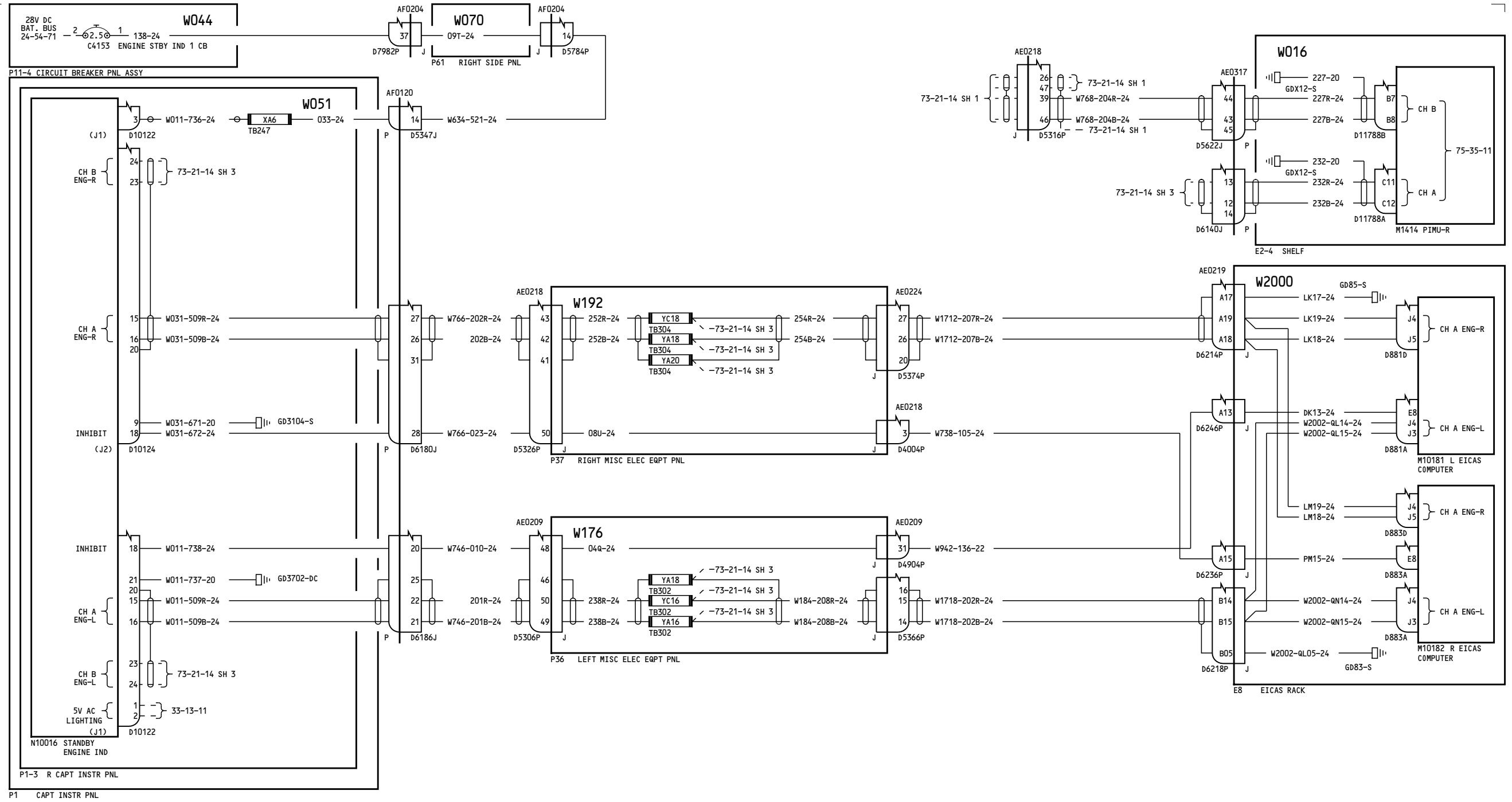

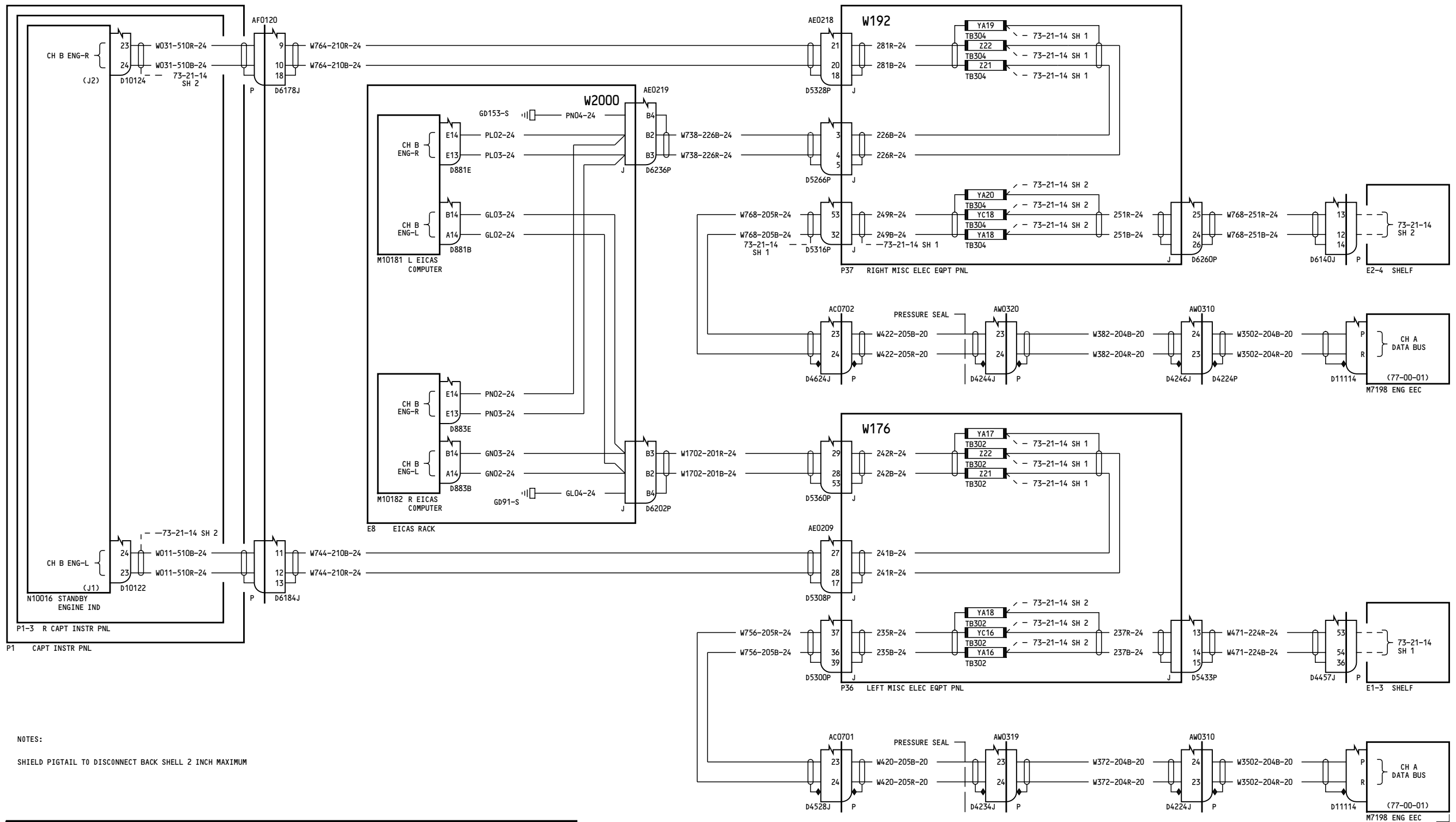

NOTES:
SHIELD PIGTAIL TO DISCONNECT BACK SHELL 2 INCH MAXIMUM

051	ELECTRONIC ENGINE CONTROL DATA BUSES D280T132
-----	---

73-21-14

Page 1.3
Sheet 3
Jan 21/2005

Incorporates
73-0036

73-21-14

Page 1.3
Sheet 3
Jan 21/2005

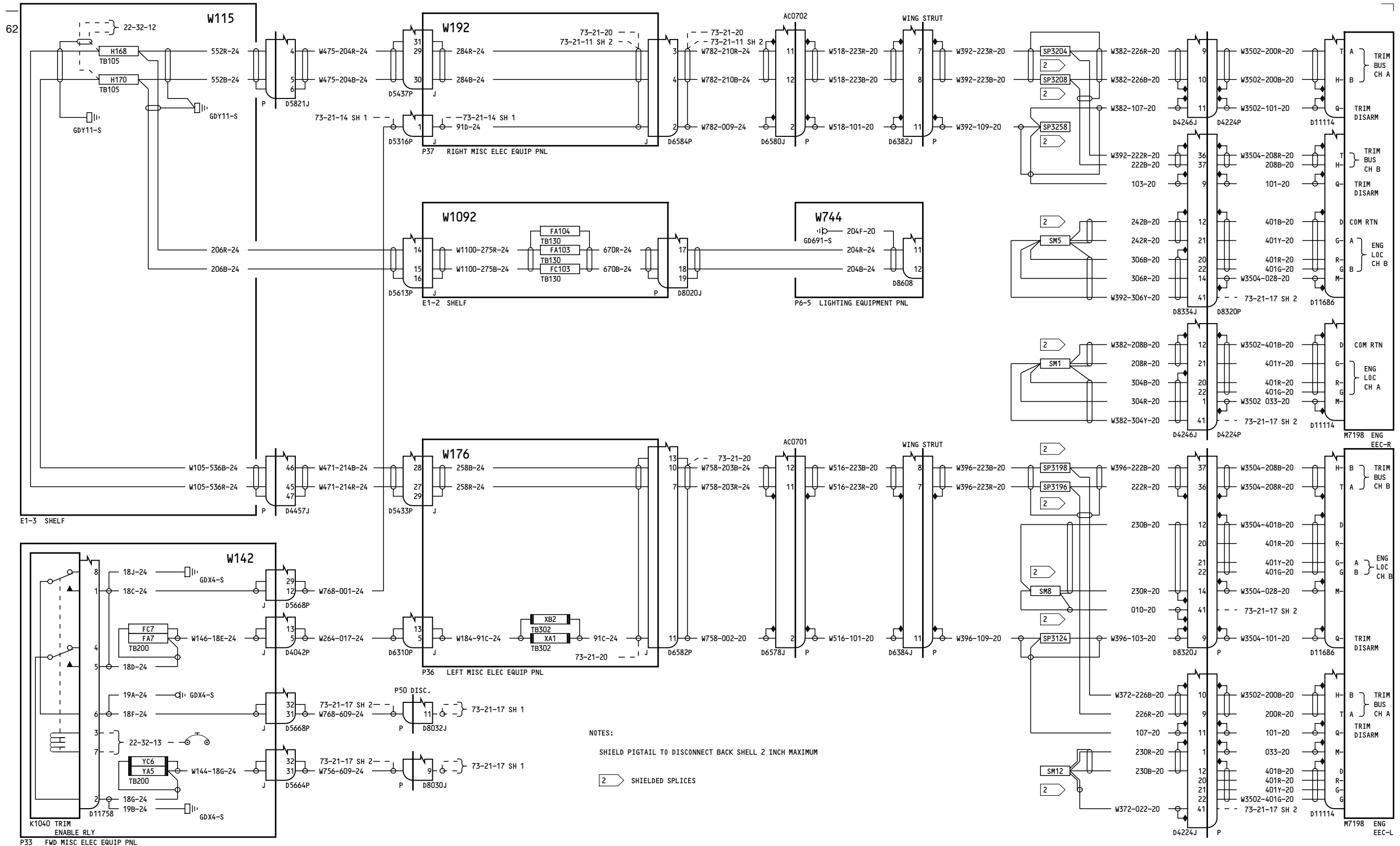

NOTES:
 SHIELD PIGTAIL TO DISCONNECT BACK SHELL 2 INCH MAXIMUM
 [Symbol] SHIELDED SPLICES

051
ELECTRONIC ENGINE CONTROL DATA BUSES
 D280T132

73-21-14
 Page 1.3
 Sheet 4
 Jan 21/2005

Incorporates
 72-0038

73-21-14
 Page 1.3
 Sheet 4
 Jan 21/2005

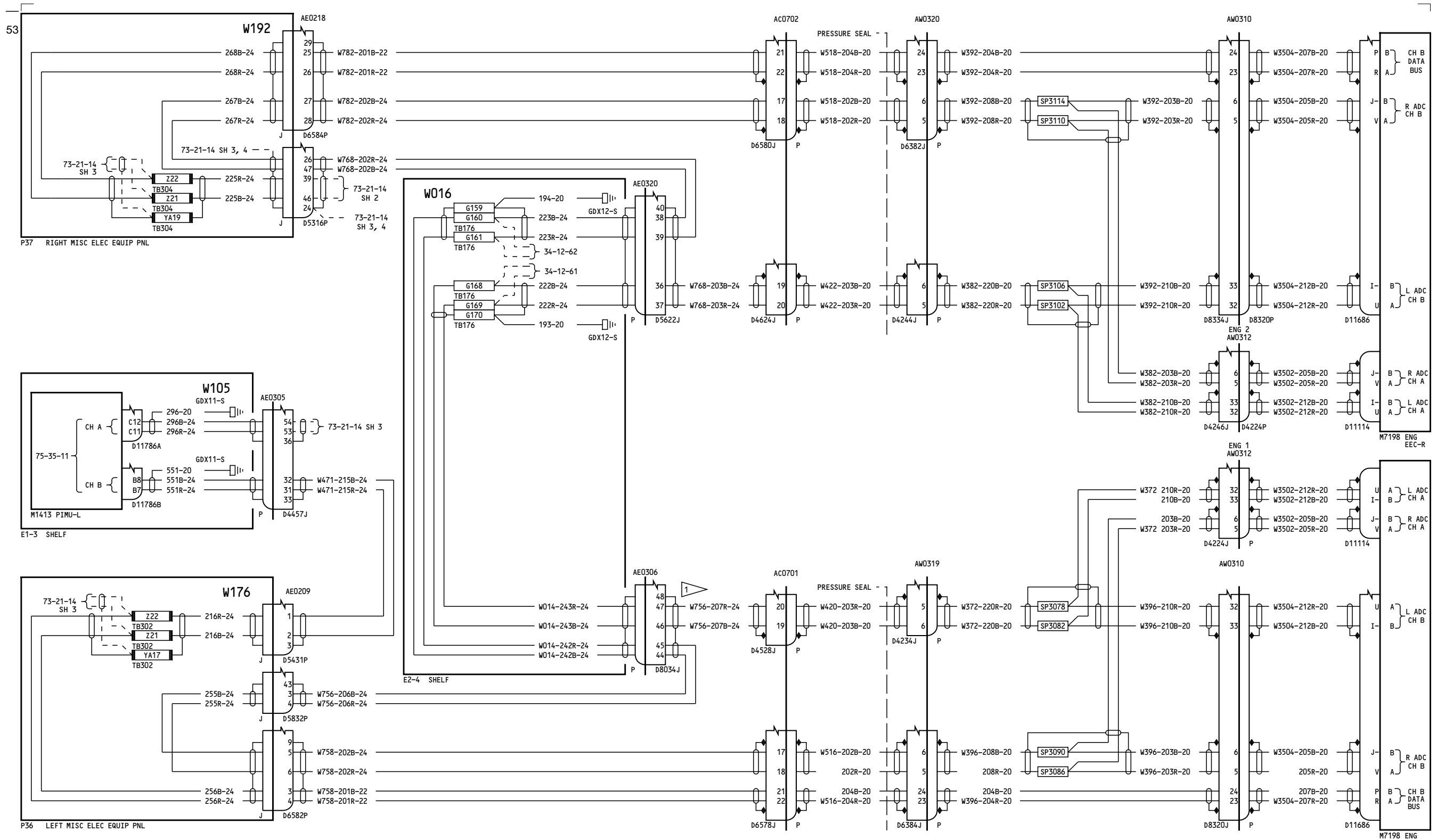

NOTES:
SHIELD PIGTAIL TO DISCONNECT
BACK SHELL 2 INCH MAXIMUM

1 SHIELD GROUND PIGTAIL 6 INCH MAXIMUM

150-154, 162-165, 275-276

ELECTRONIC ENGINE CONTROL DATA BUSES

D280T132

73-21-14

Page 2.1
Sheet 1
Jan 21/2005

73-21-14

Page 2.1
Sheet 1
Jan 21/2005

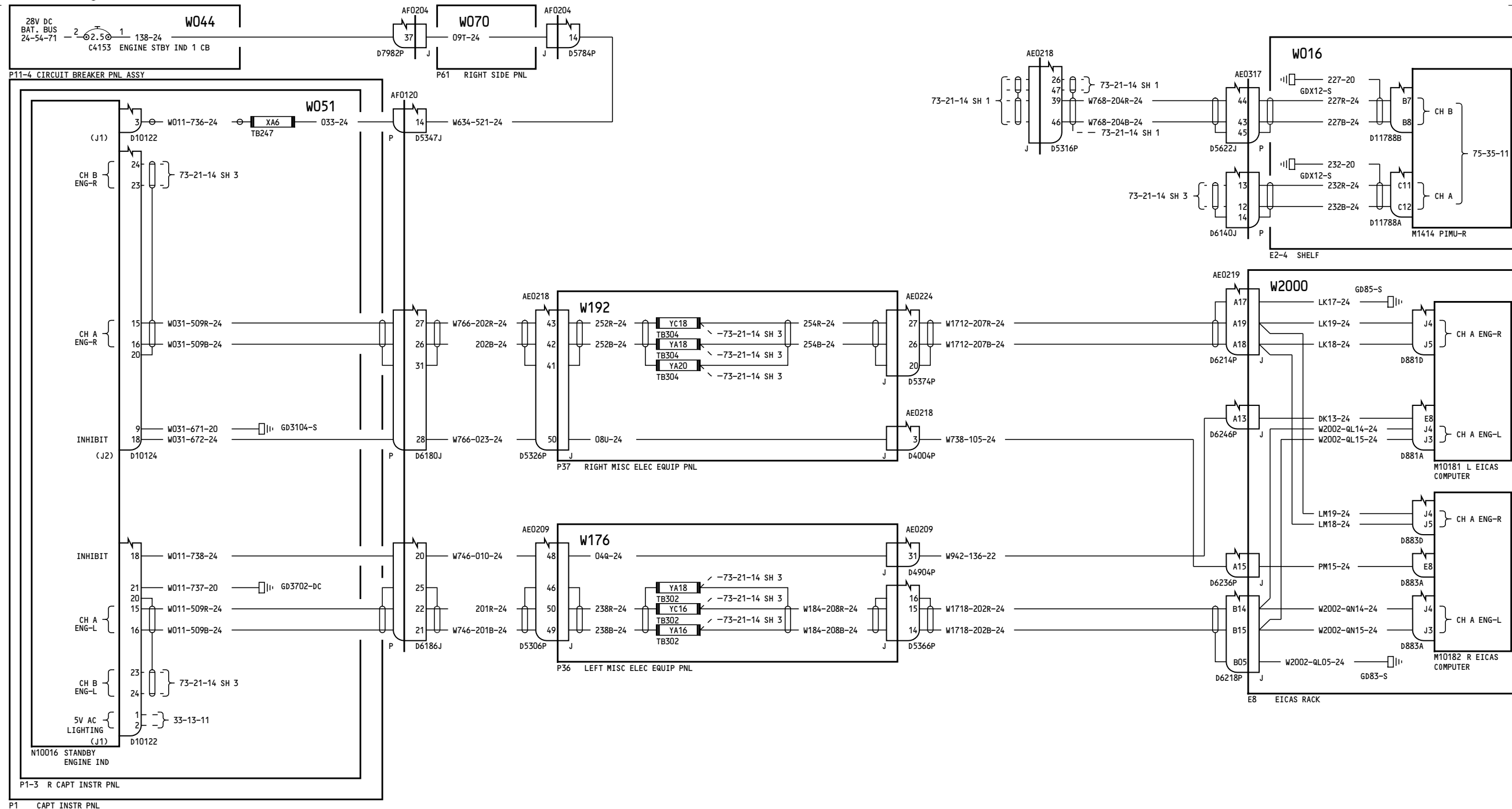

150-154, 162-165, 275-276

ELECTRONIC ENGINE CONTROL DATA BUSES

73-21-14

Page 2.1
Sheet 2
Jan 21/2005

D280T132

73-21-14

Page 2.1
Sheet 2
Jan 21/2005

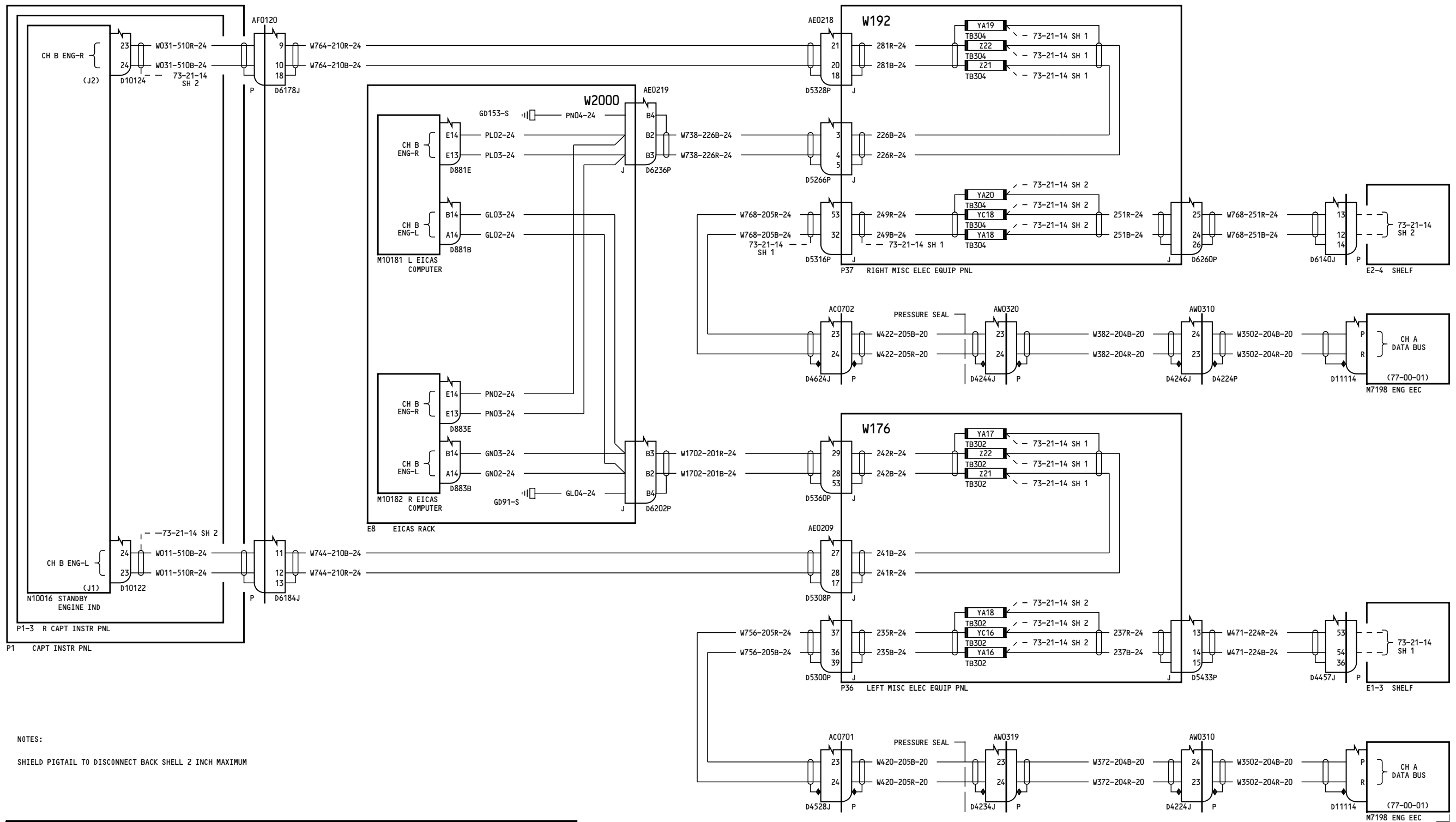

NOTES:
SHIELD PIGTAIL TO DISCONNECT BACK SHELL 2 INCH MAXIMUM

150-154, 162-165, 275-276

ELECTRONIC ENGINE CONTROL DATA BUSES

D280T132

73-21-14

Page 2.1
Sheet 3
Jan 21/2005

Incorporates
73-0036

73-21-14

Page 2.1
Sheet 3
Jan 21/2005

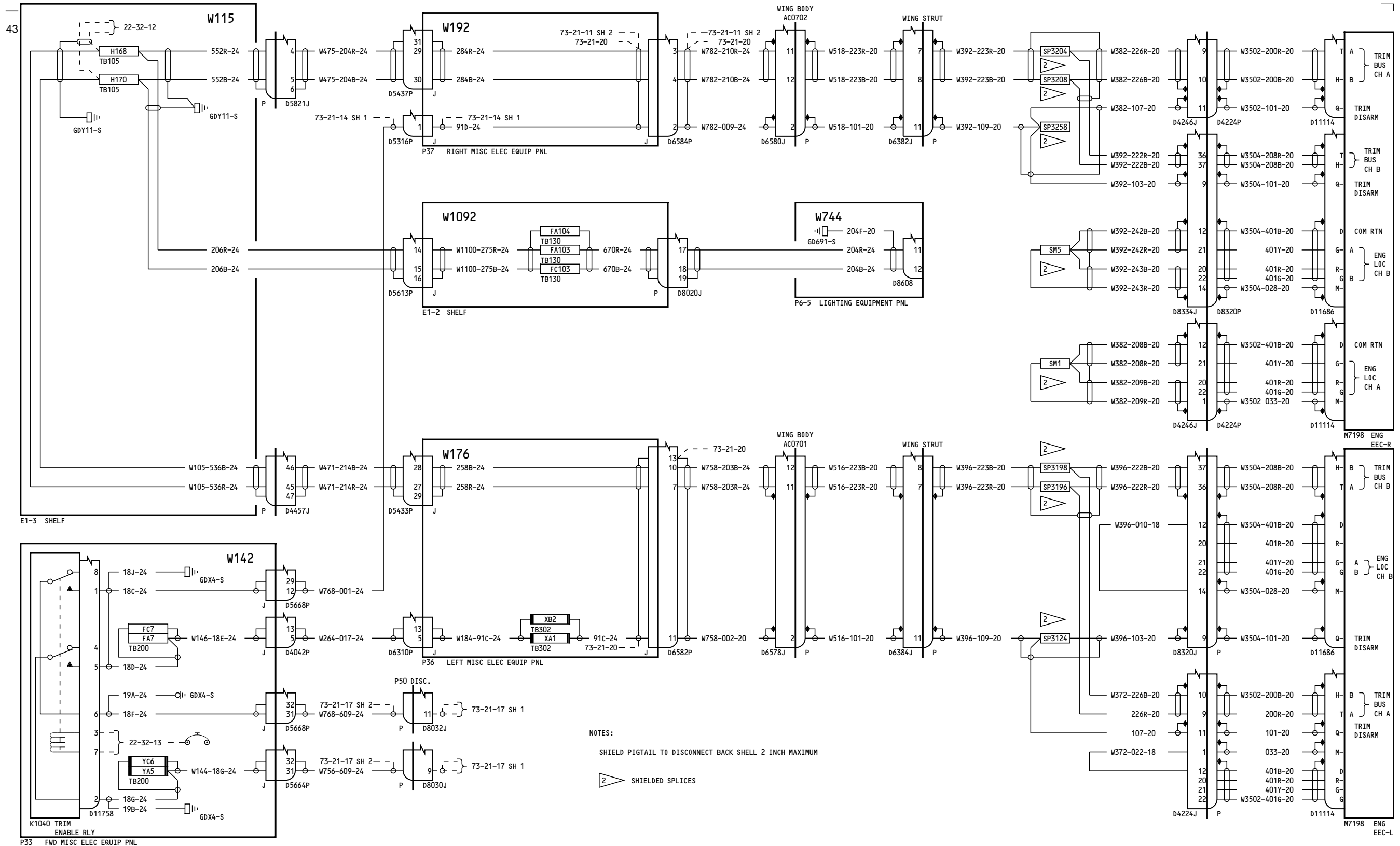

150-154, 162-165, 275-276

ELECTRONIC ENGINE CONTROL DATA BUSES

73-21-14

Page 2.1
Sheet 4
Jan 21/2005

D280T132

73-21-14

Page 2.1
Sheet 4
Jan 21/2005

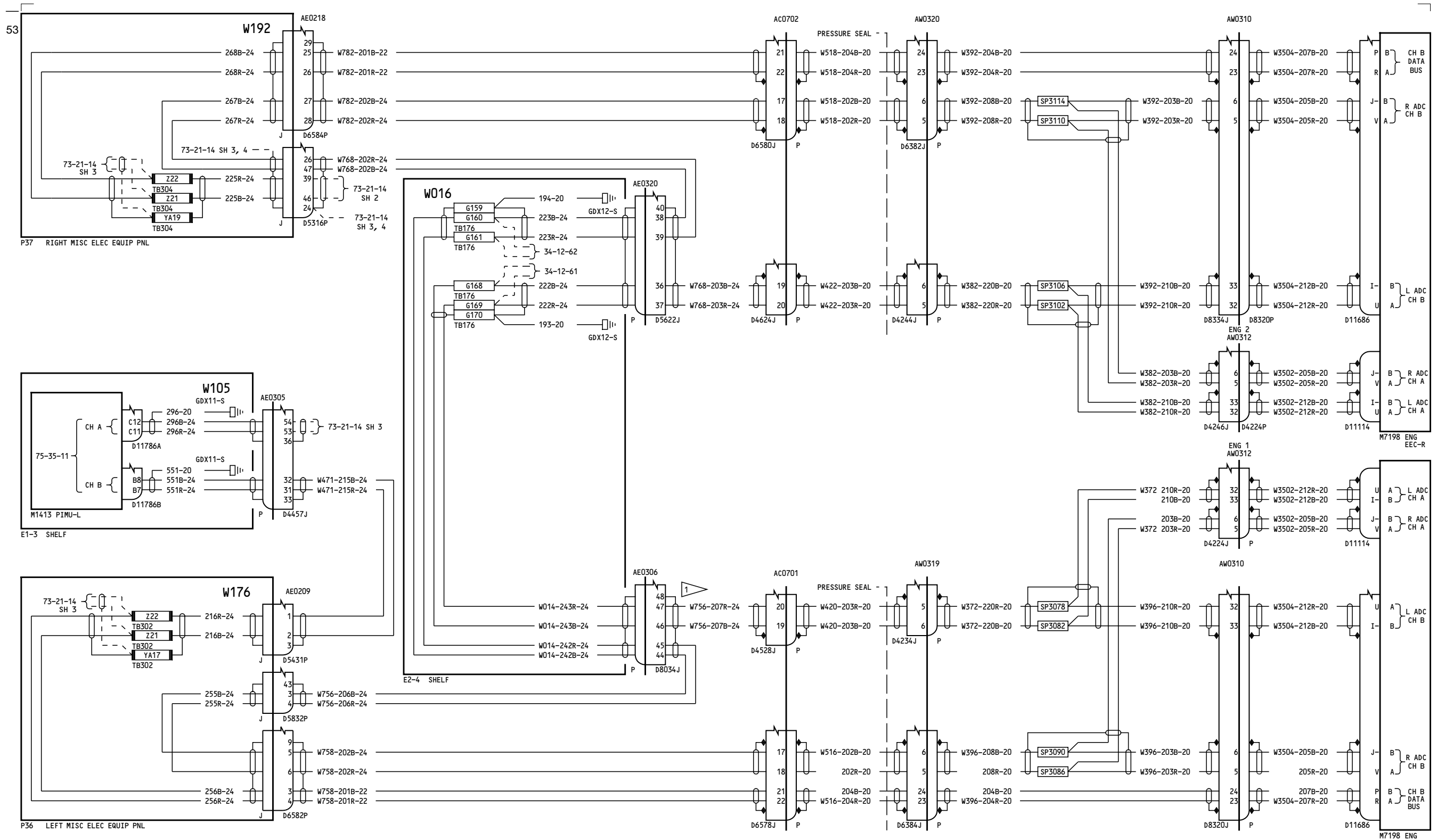

NOTES:
SHIELD PIGTAIL TO DISCONNECT
BACK SHELL 2 INCH MAXIMUM

1 SHIELD GROUND PIGTAIL 6 INCH MAXIMUM

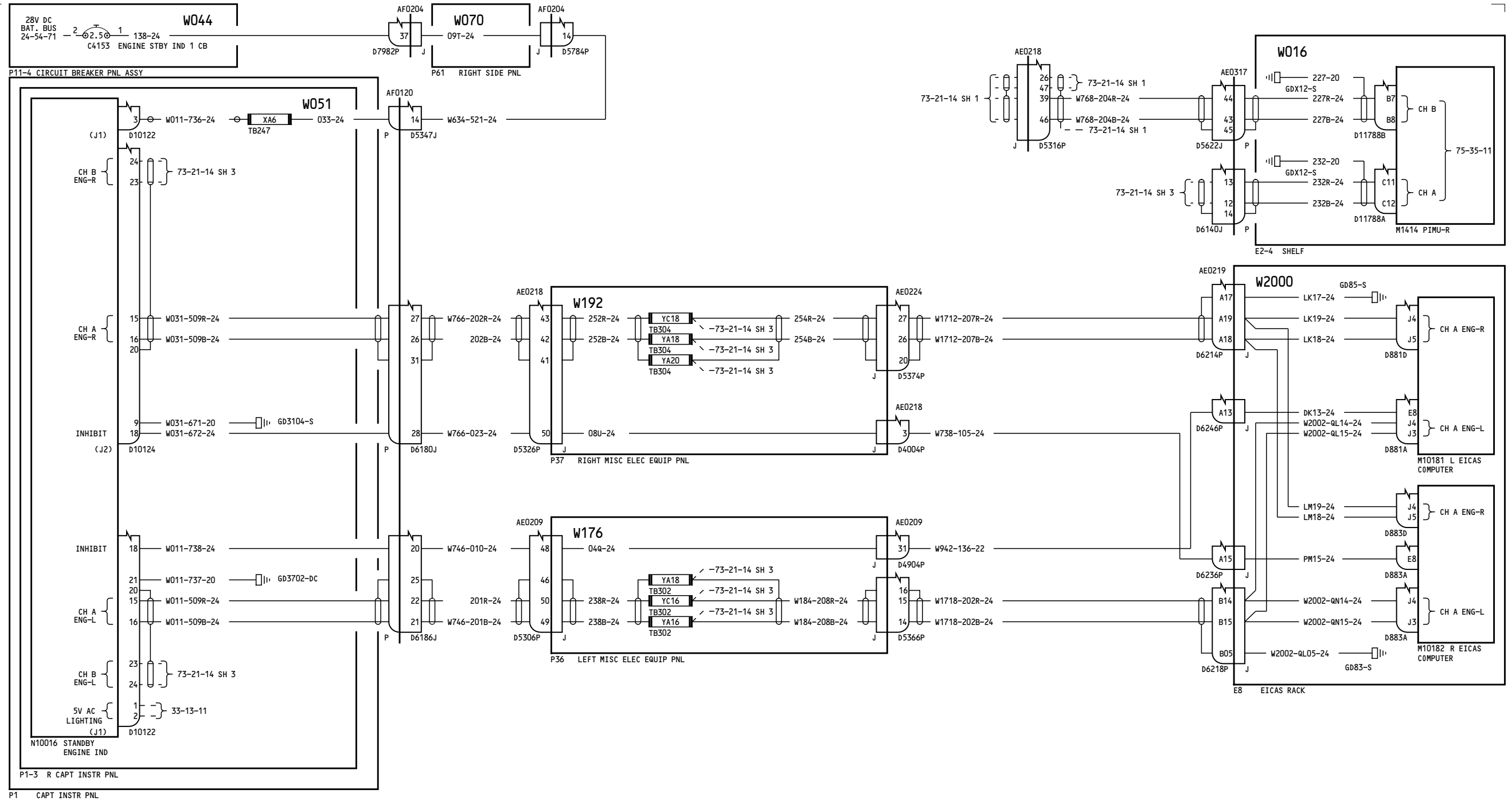

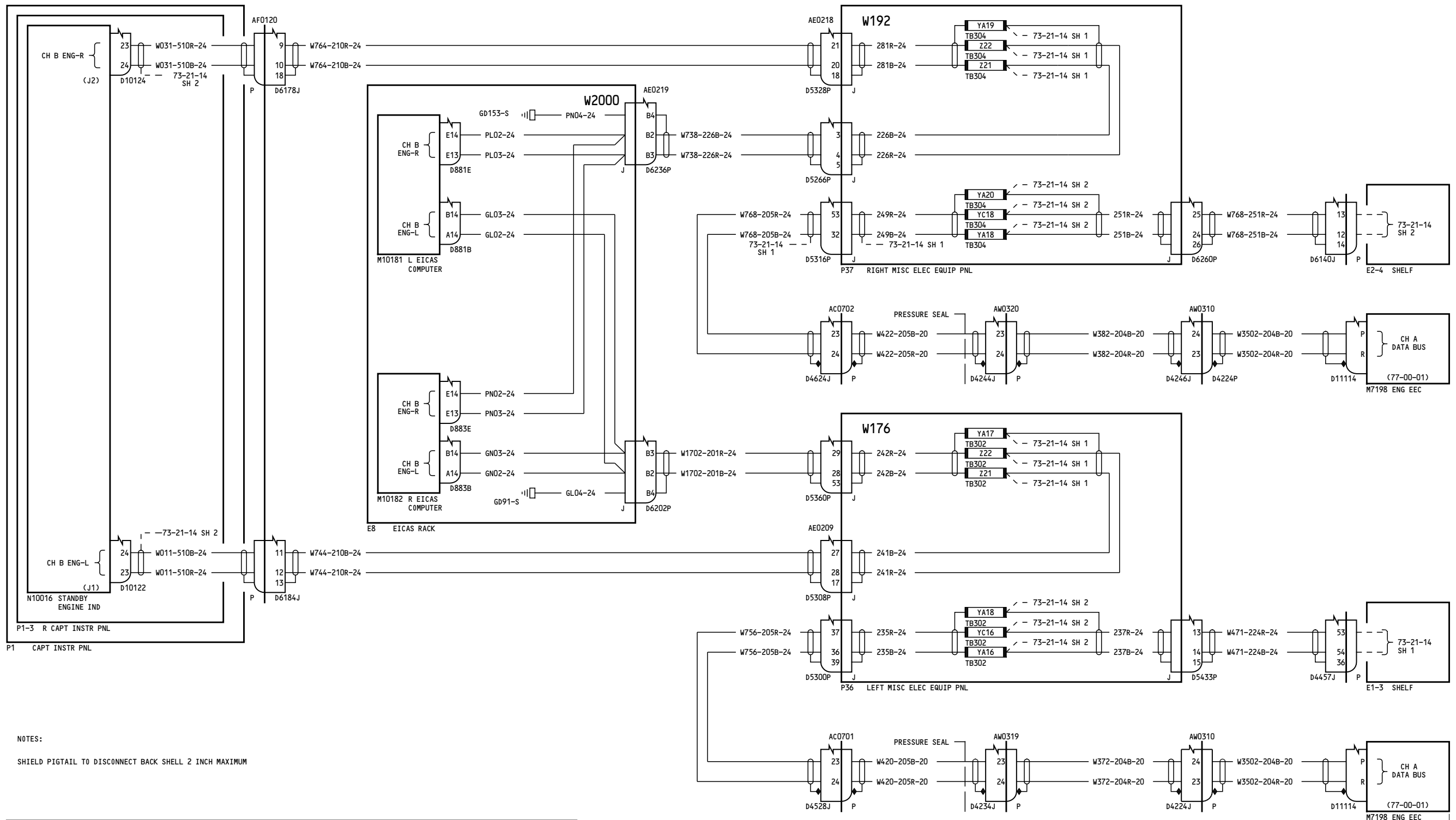

NOTES:
SHIELD PIGTAIL TO DISCONNECT BACK SHELL 2 INCH MAXIMUM

151	<p>ELECTRONIC ENGINE CONTROL DATA BUSES</p> <p>D280T132</p>
-----	--

73-21-14

Page 2.2
Sheet 3
Jan 21/2005

Incorporates
73-0036

73-21-14

Page 2.2
Sheet 3
Jan 21/2005

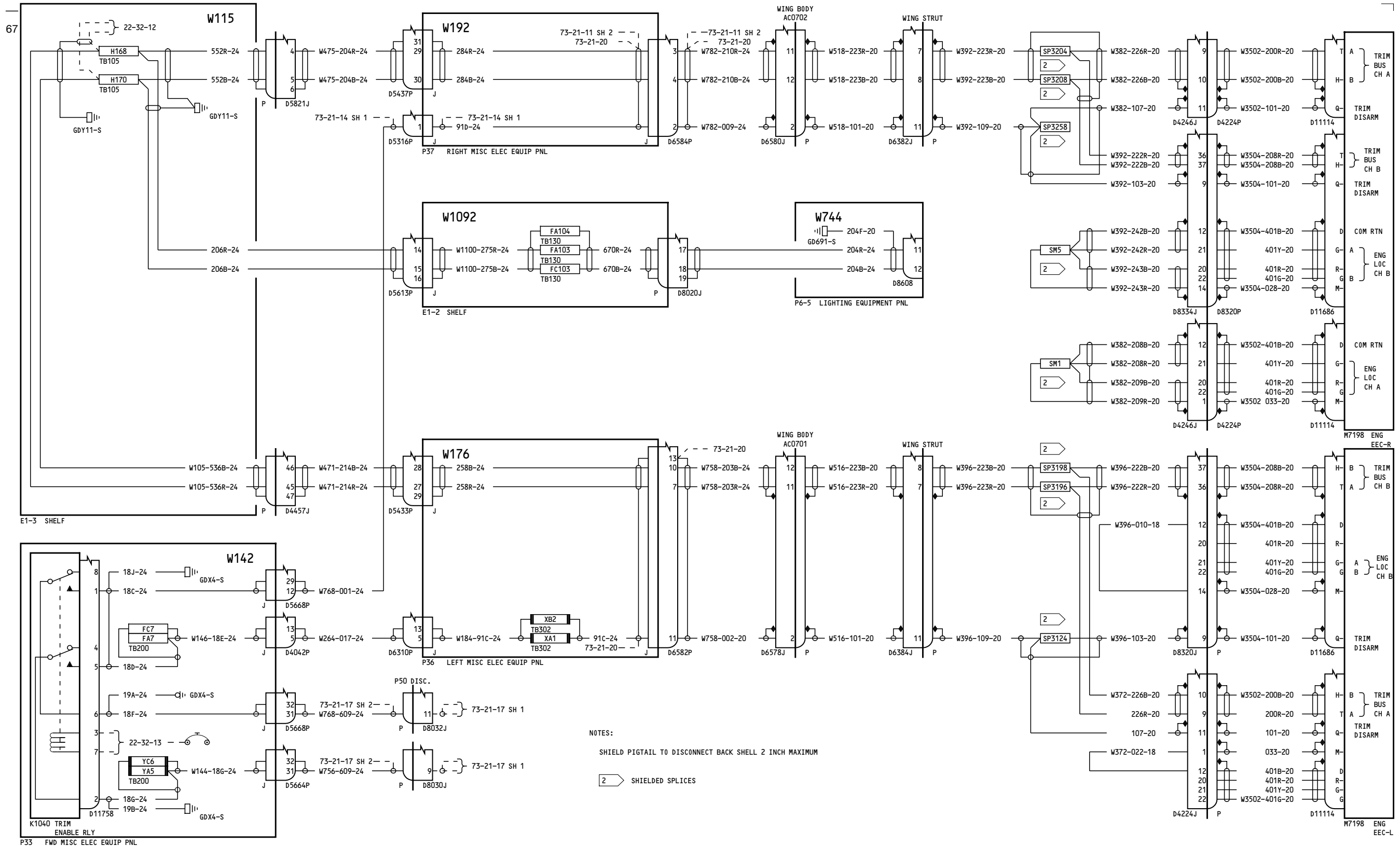

NOTES:
 SHIELD PIGTAIL TO DISCONNECT BACK SHELL 2 INCH MAXIMUM
 [Symbol] SHIELDED SPLICES

151

ELECTRONIC ENGINE CONTROL DATA BUSES
 D280T132

73-21-14

Page 2.2
 Sheet 4
 Jan 21/2005

Incorporates
 72-0038

73-21-14

Page 2.2
 Sheet 4
 Jan 21/2005

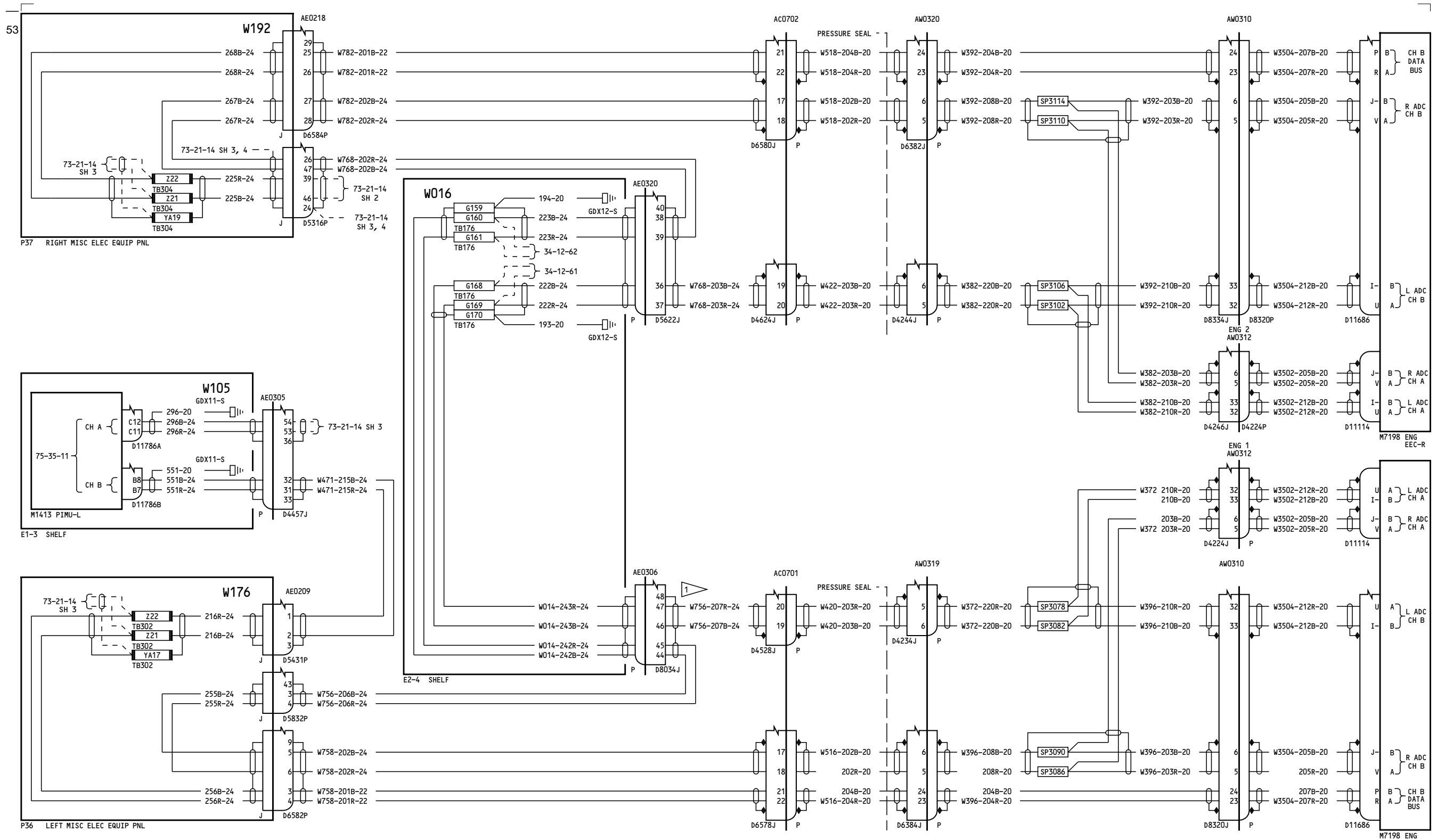

NOTES:
SHIELD PIGTAIL TO DISCONNECT
BACK SHELL 2 INCH MAXIMUM

1 SHIELD GROUND PIGTAIL 6 INCH MAXIMUM

153

ELECTRONIC ENGINE CONTROL DATA BUSES

D280T132

73-21-14

Page 2.3
Sheet 1
Jan 21/2005

73-21-14

Page 2.3
Sheet 1
Jan 21/2005

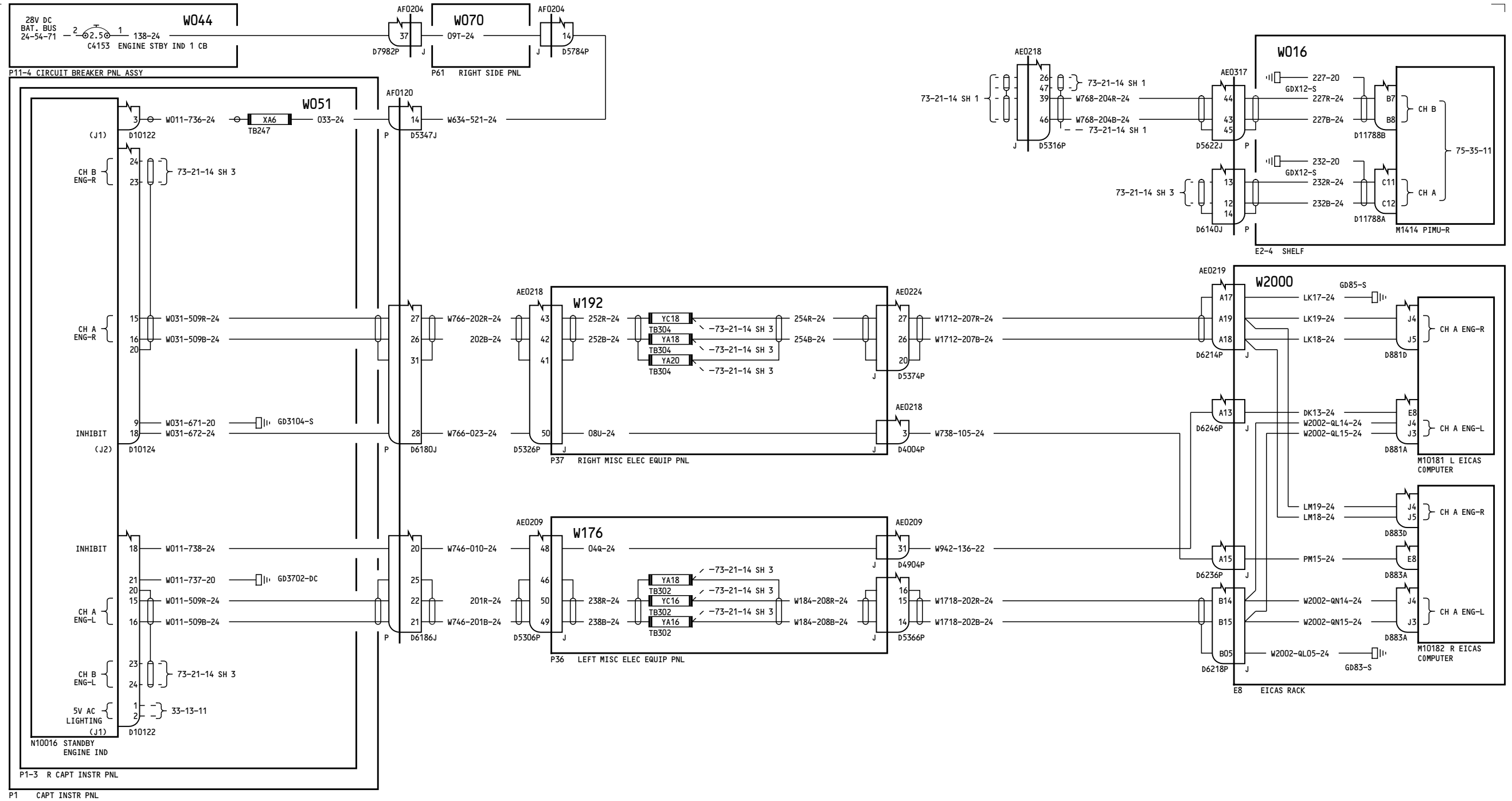

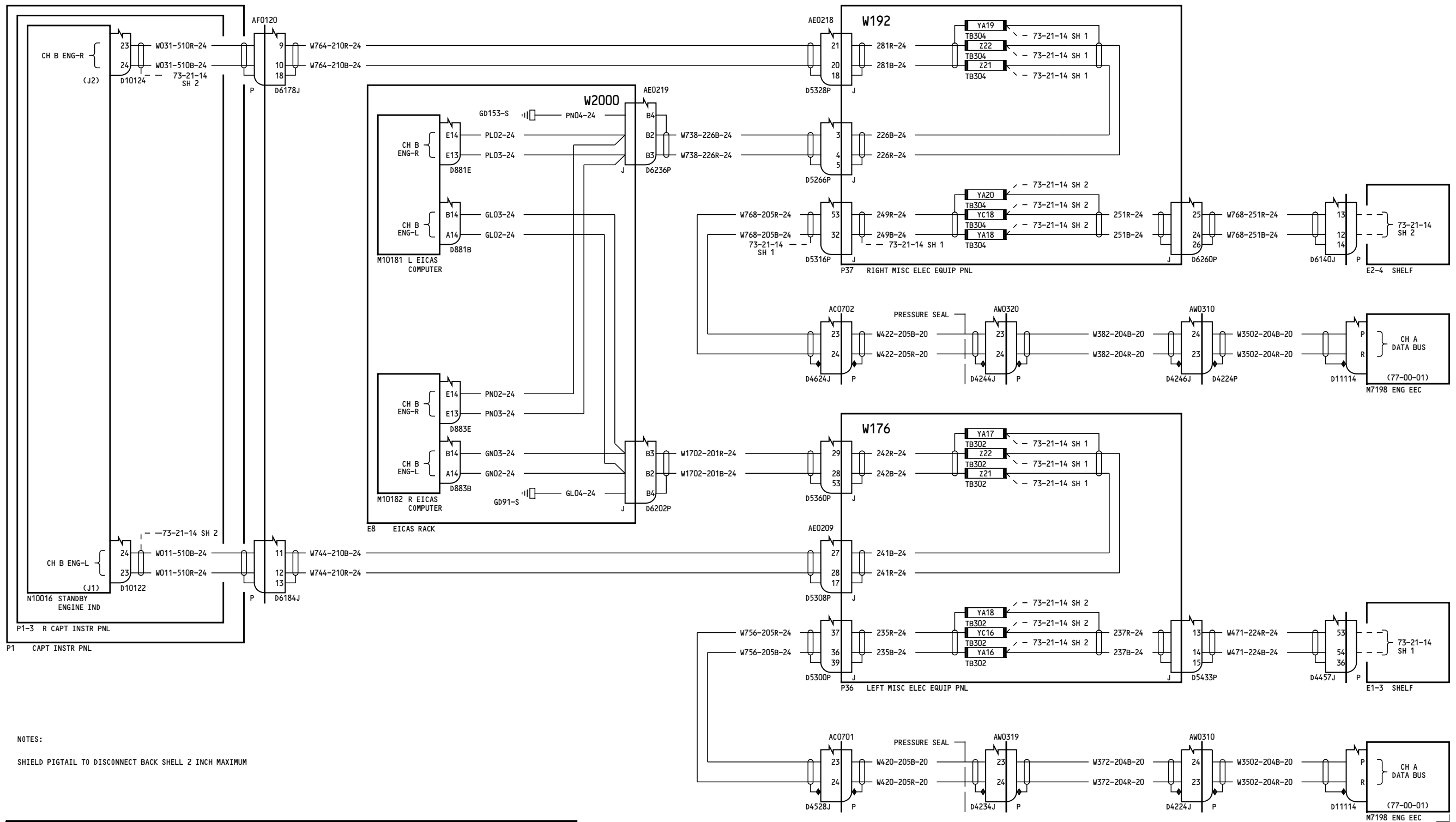

NOTES:
SHIELD PIGTAIL TO DISCONNECT BACK SHELL 2 INCH MAXIMUM

153

ELECTRONIC ENGINE CONTROL DATA BUSES

D280T132

73-21-14
Page 2.3
Sheet 3
Jan 21/2005

Incorporates
73-0036

73-21-14
Page 2.3
Sheet 3
Jan 21/2005

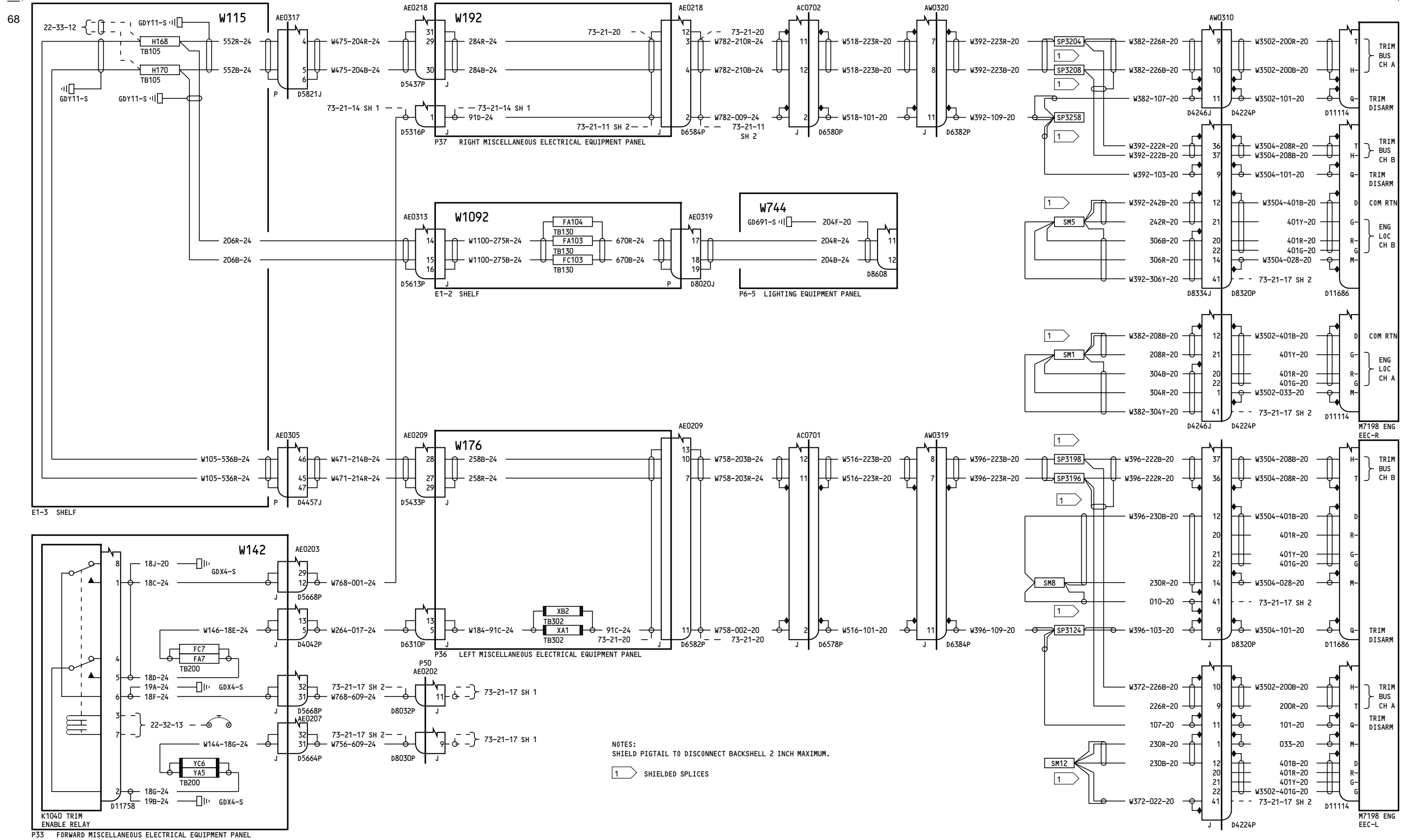

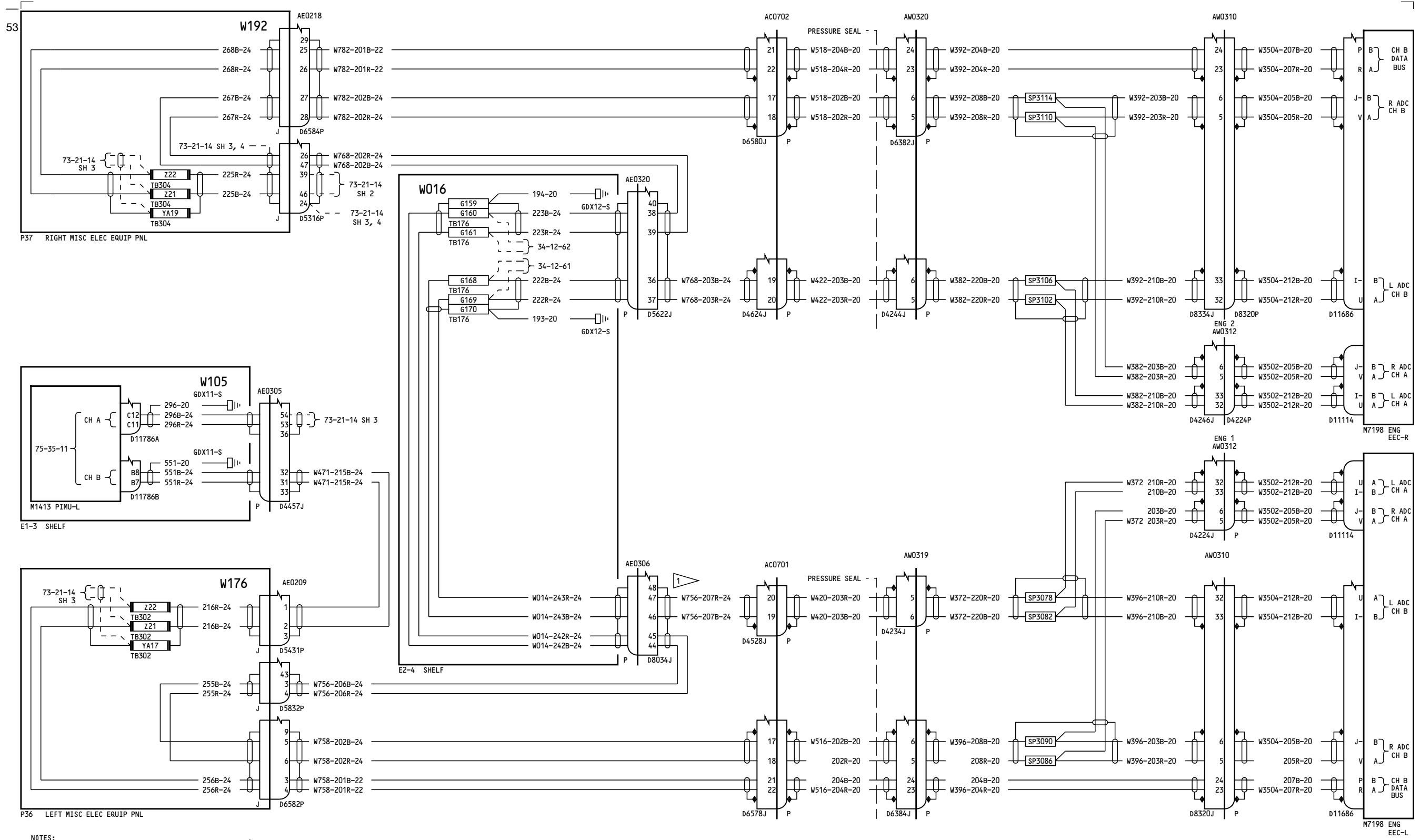

NOTES:
 SHIELD PIGTAIL TO DISCONNECT
 BACK SHELL 2 INCH MAXIMUM

SHIELD GROUND PIGTAIL 6 INCH MAXIMUM

155-157, 166-199

**ELECTRONIC ENGINE CONTROL
 DATA BUSES**

 D280T132

73-21-14

 Page 3
 Sheet 1
 Jan 21/2005

73-21-14

 Page 3
 Sheet 1
 Jan 21/2005

51

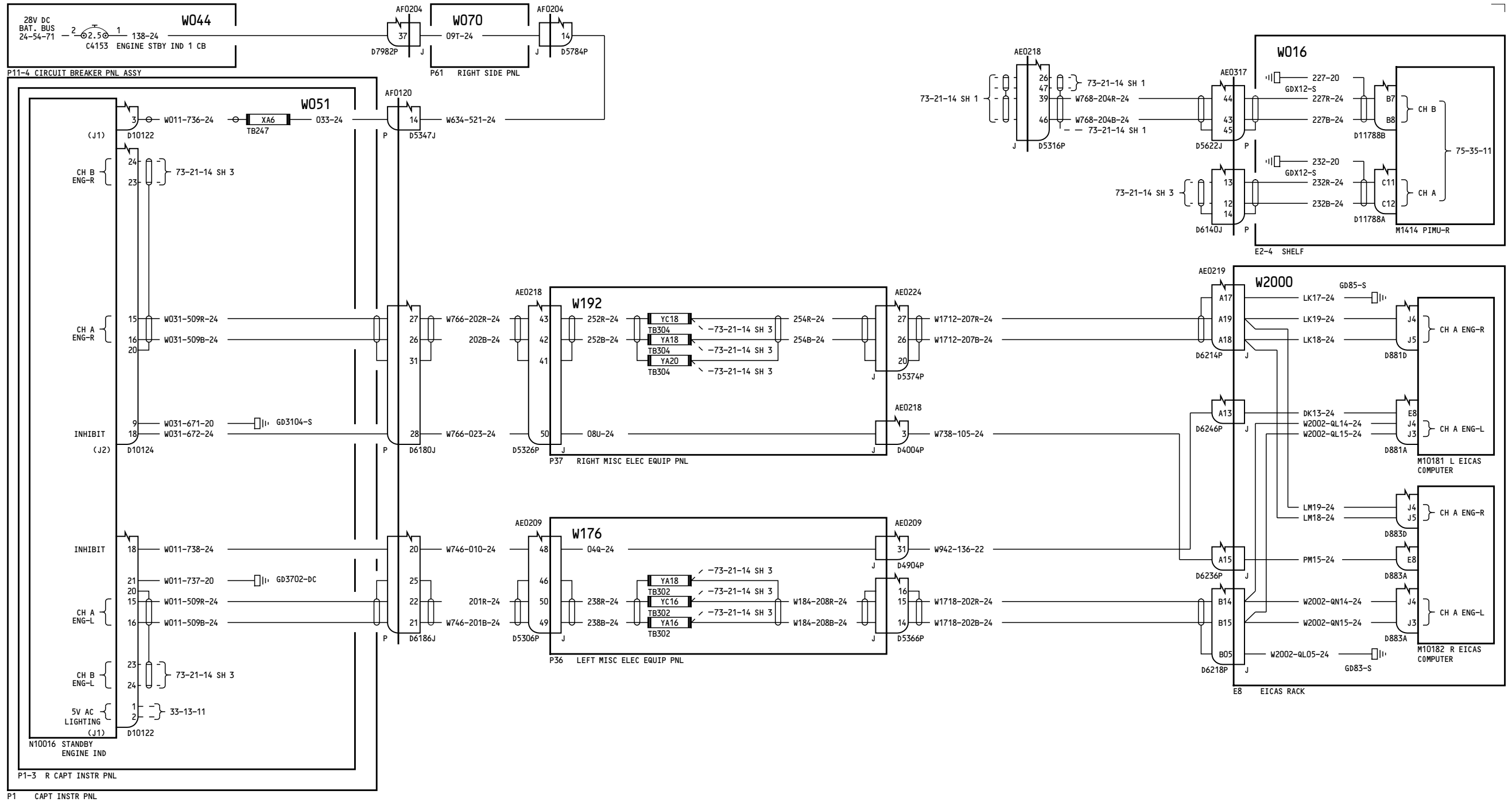

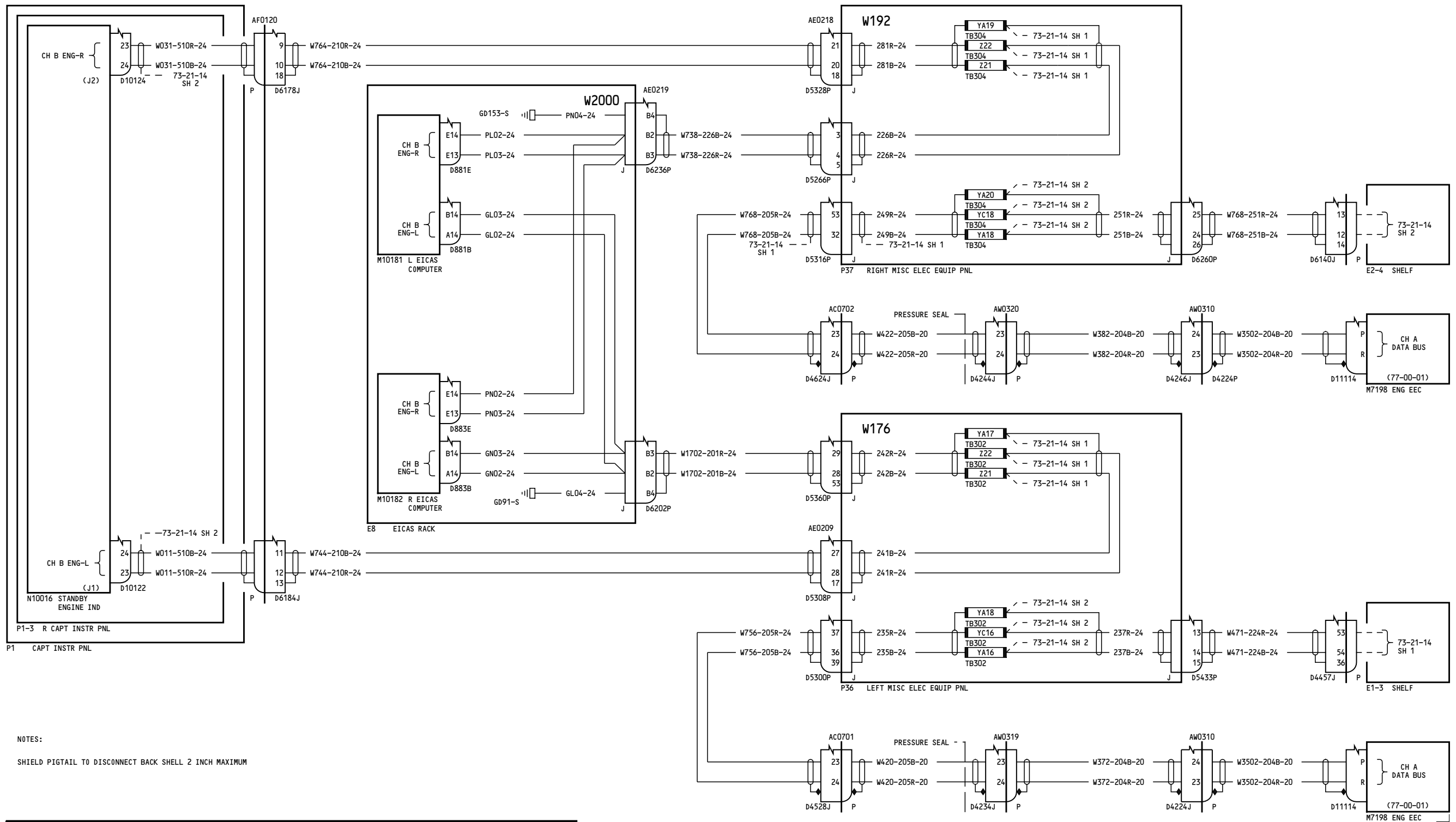

NOTES:
SHIELD PIGTAIL TO DISCONNECT BACK SHELL 2 INCH MAXIMUM

155-157, 166-199

ELECTRONIC ENGINE CONTROL DATA BUSES

D280T132

73-21-14

Page 3
Sheet 3
Jan 21/2005

73-21-14

Page 3
Sheet 3
Jan 21/2005

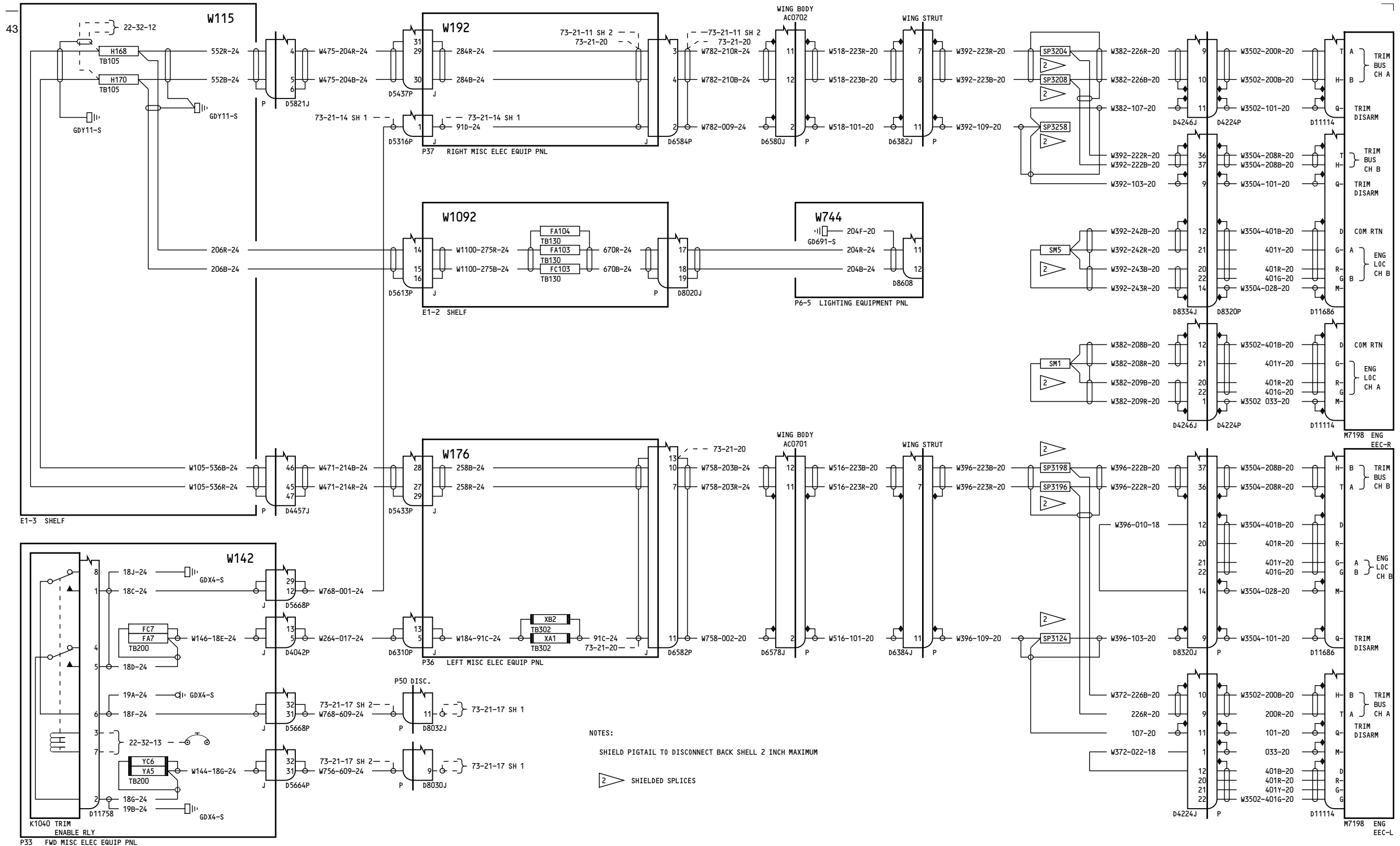

155-157, 166-199

ELECTRONIC ENGINE CONTROL DATA BUSES

D280T132

73-21-14

Page 3
Sheet 4
Jan 21/2005

73-21-14

Page 3
Sheet 4
Jan 21/2005

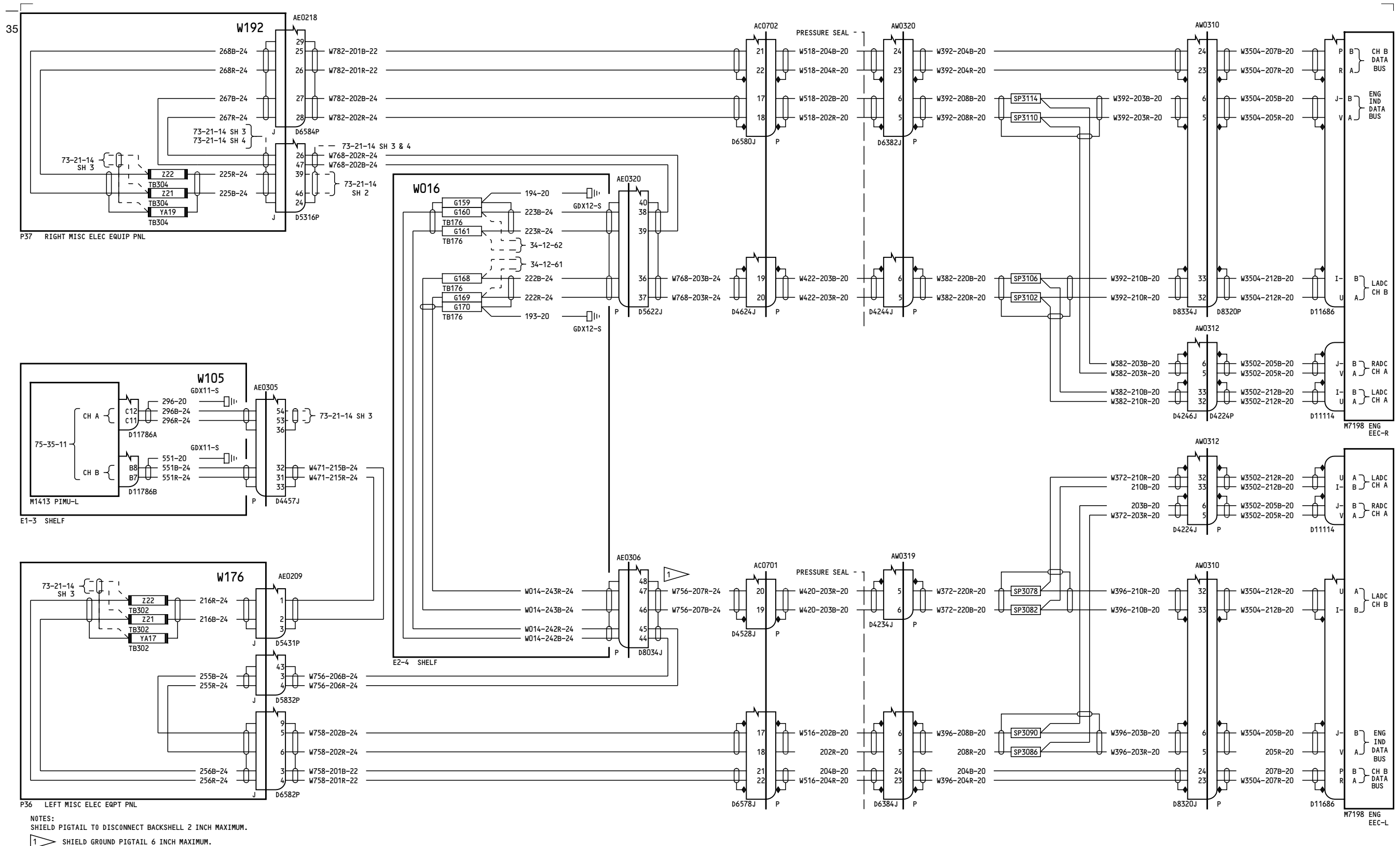

277-299

ELECTRONIC ENGINE CONTROL DATA BUSES

73-21-14

D280T132

Page 4
 Sheet 1
 Jan 21/2005

73-21-14

Page 4
 Sheet 1
 Jan 21/2005

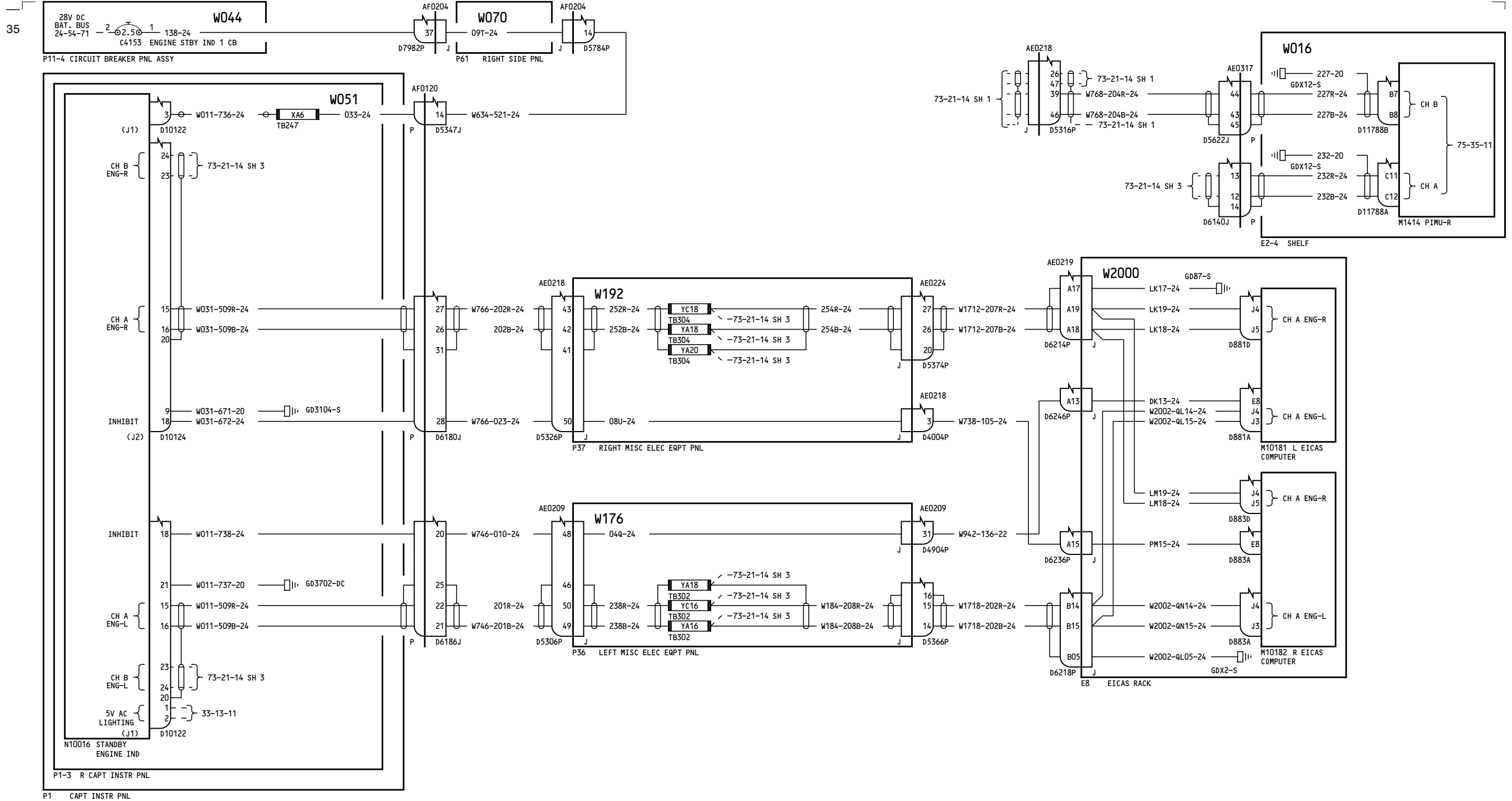

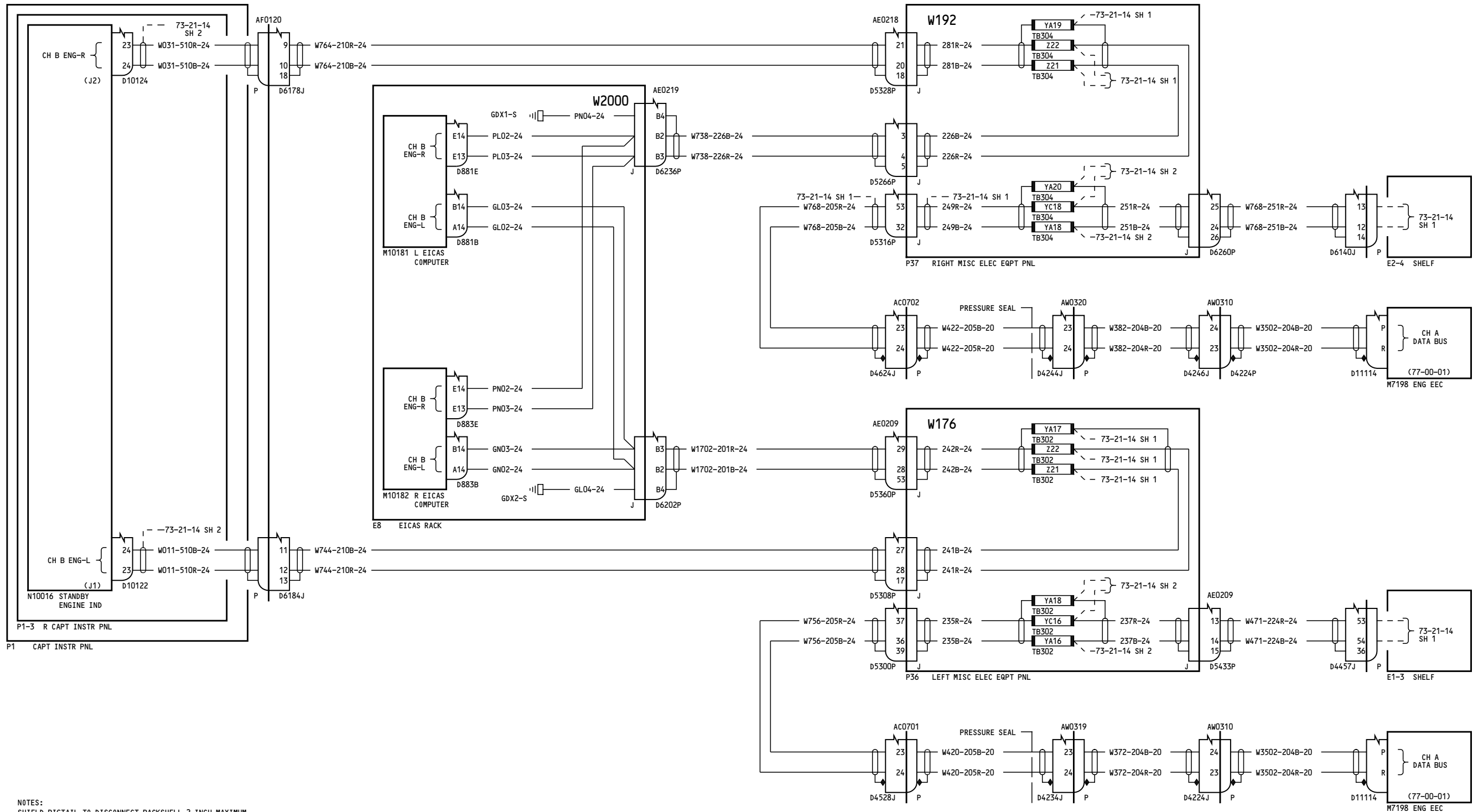

NOTES:
SHIELD PIGTAIL TO DISCONNECT BACKSHELL 2 INCH MAXIMUM

277-299

ELECTRONIC ENGINE CONTROL DATA BUSES

D280T132

73-21-14

Page 4
Sheet 3
Jan 21/2005

73-21-14

Page 4
Sheet 3
Jan 21/2005

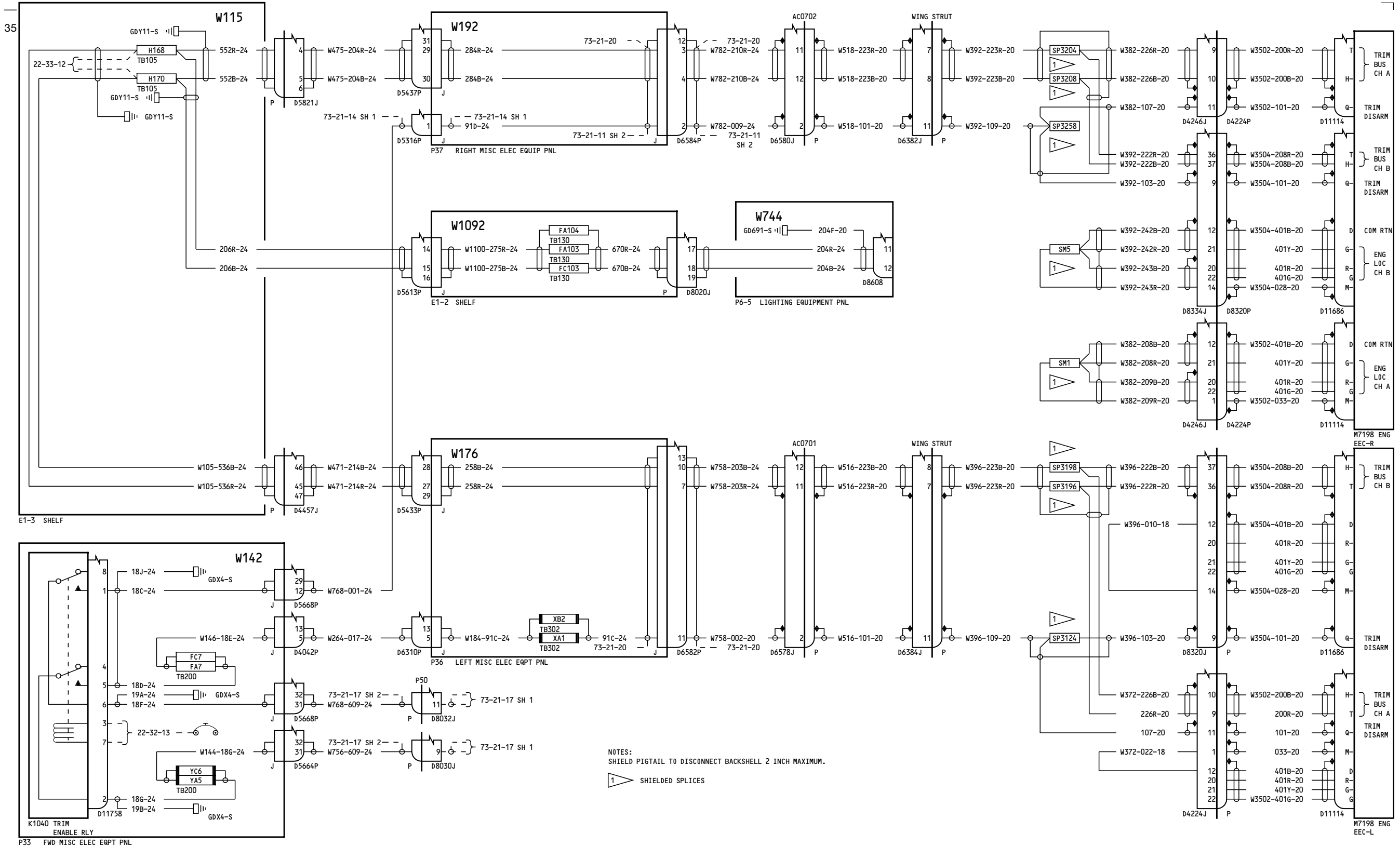

NOTES:
SHIELD PIGTAIL TO DISCONNECT BACKSHELL 2 INCH MAXIMUM.
1 SHIELDED SPLICES

277-299

ELECTRONIC ENGINE CONTROL DATA BUSES
73-21-14
D280T132

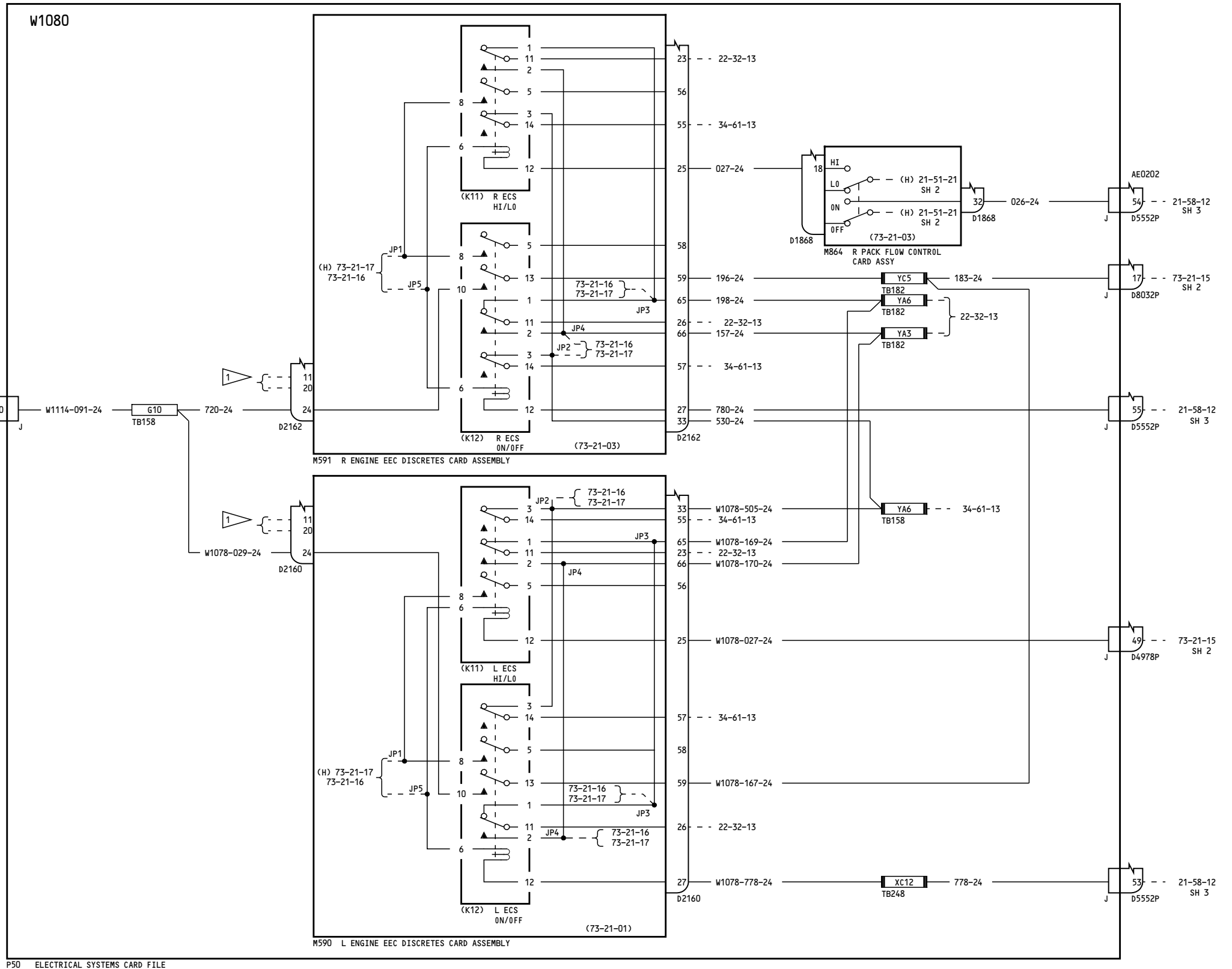
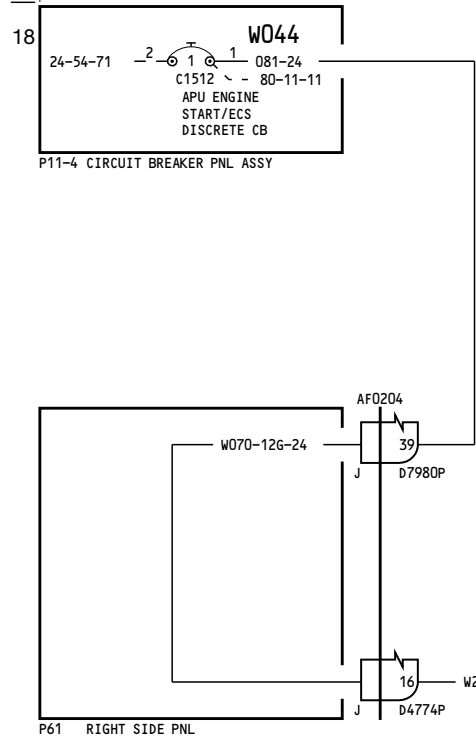

NOTES:
1 CONNECTOR KEYING PLUGS

050-099, 153-199, 277-299

ELECTRONIC ENGINE CONTROL ENVIRONMENTAL CONTROL SYSTEM DISCRETES

D280T132

73-21-15

Page 1
Sheet 1
Jan 21/2005

73-21-15

Page 1
Sheet 1
Jan 21/2005

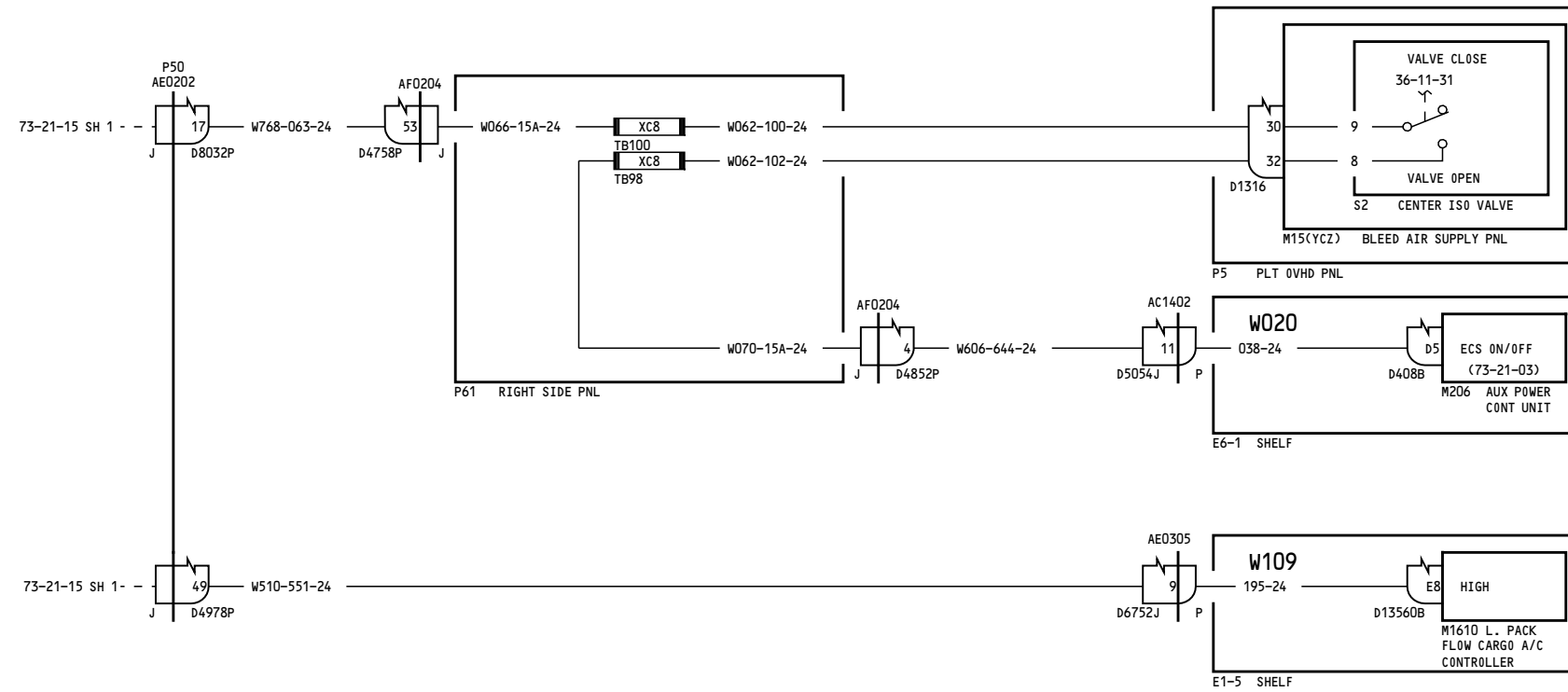

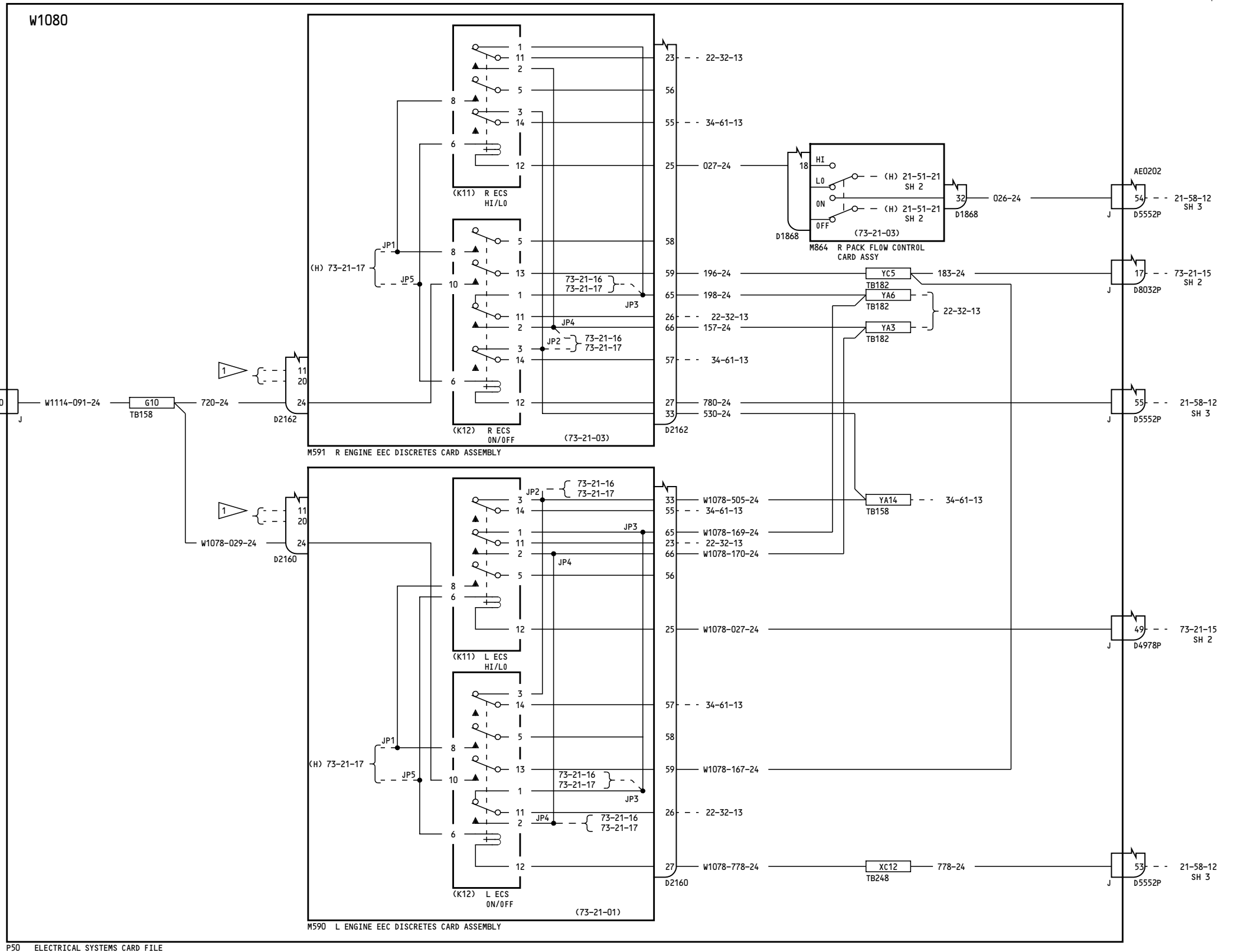
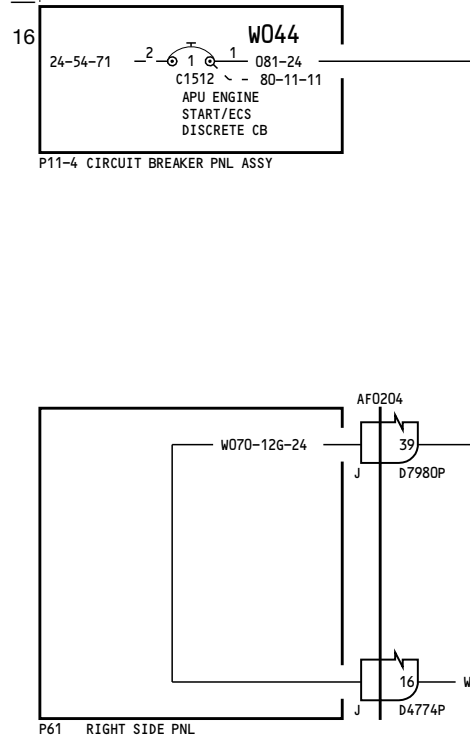

NOTES:
 1 CONNECTOR KEYING PLUGS

150-152, 275-276

**ELECTRONIC ENGINE CONTROL
 ENVIRONMENTAL CONTROL
 SYSTEM DISCRETES**

D280T132

73-21-15

Page 2
 Sheet 1
 Jan 21/2005

73-21-15

Page 2
 Sheet 1
 Jan 21/2005

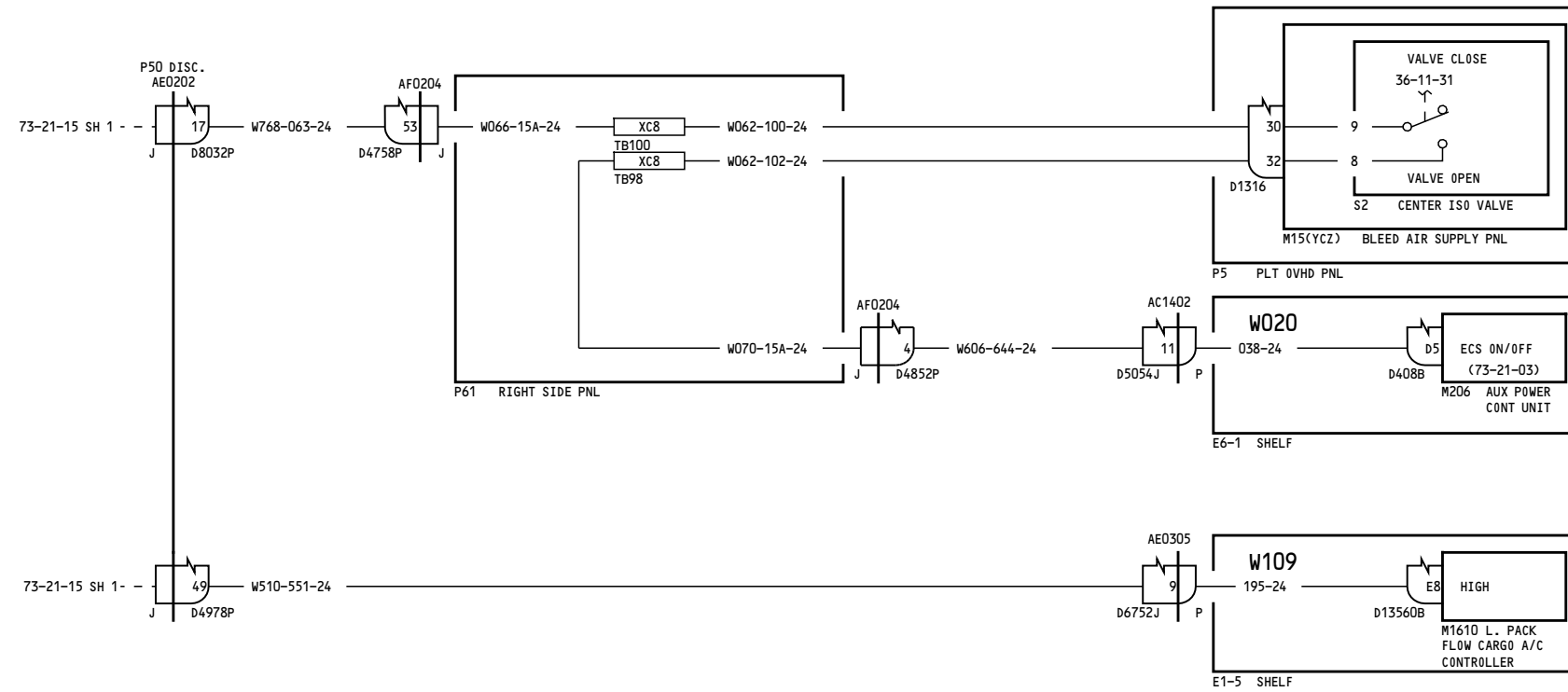

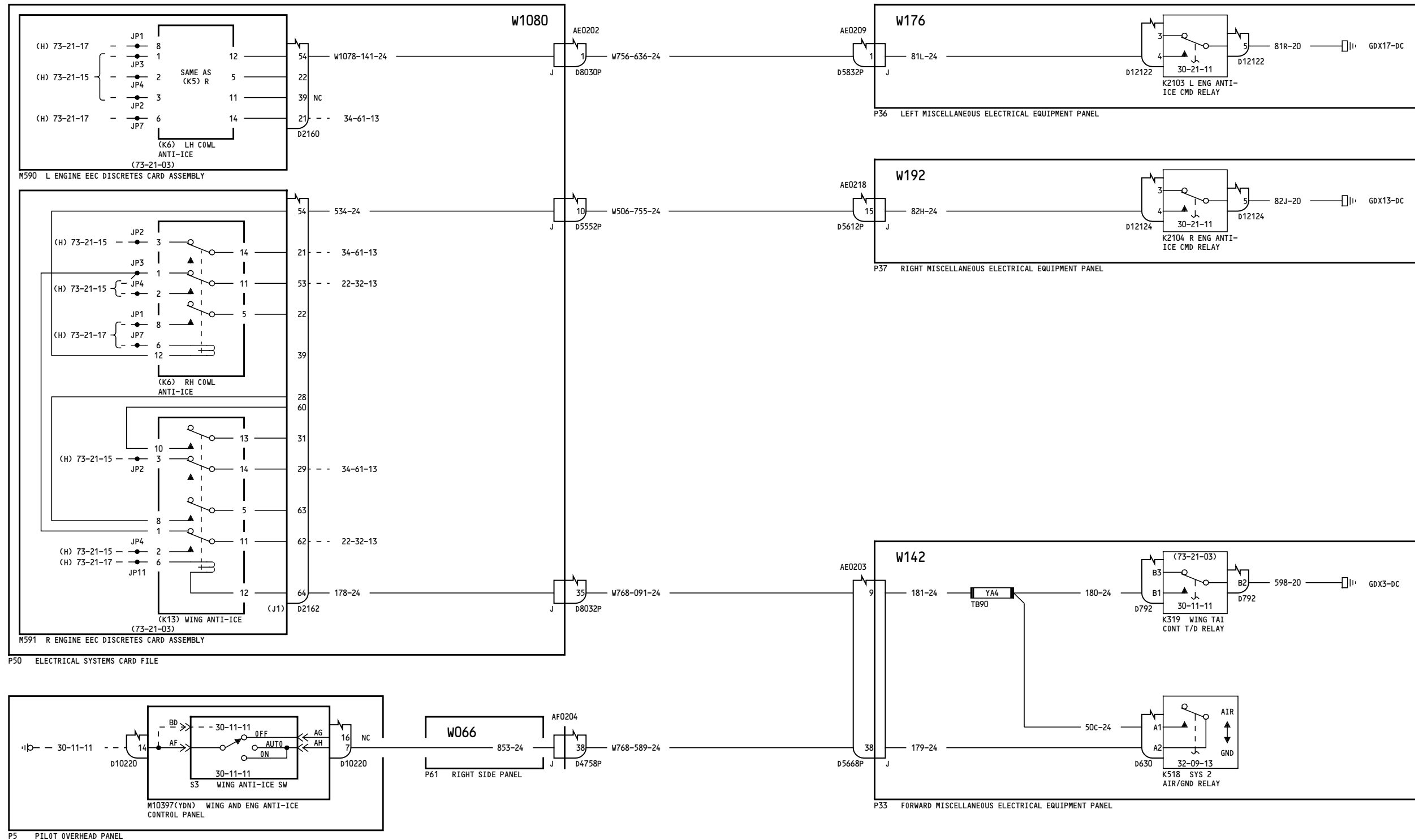

050-099

ELECTRONIC ENGINE CONTROL ANTI-ICE DISCRETES

73-21-16

Page 1

Jan 21/2005

D280T132

73-21-16

Page 1

Jan 21/2005

-A

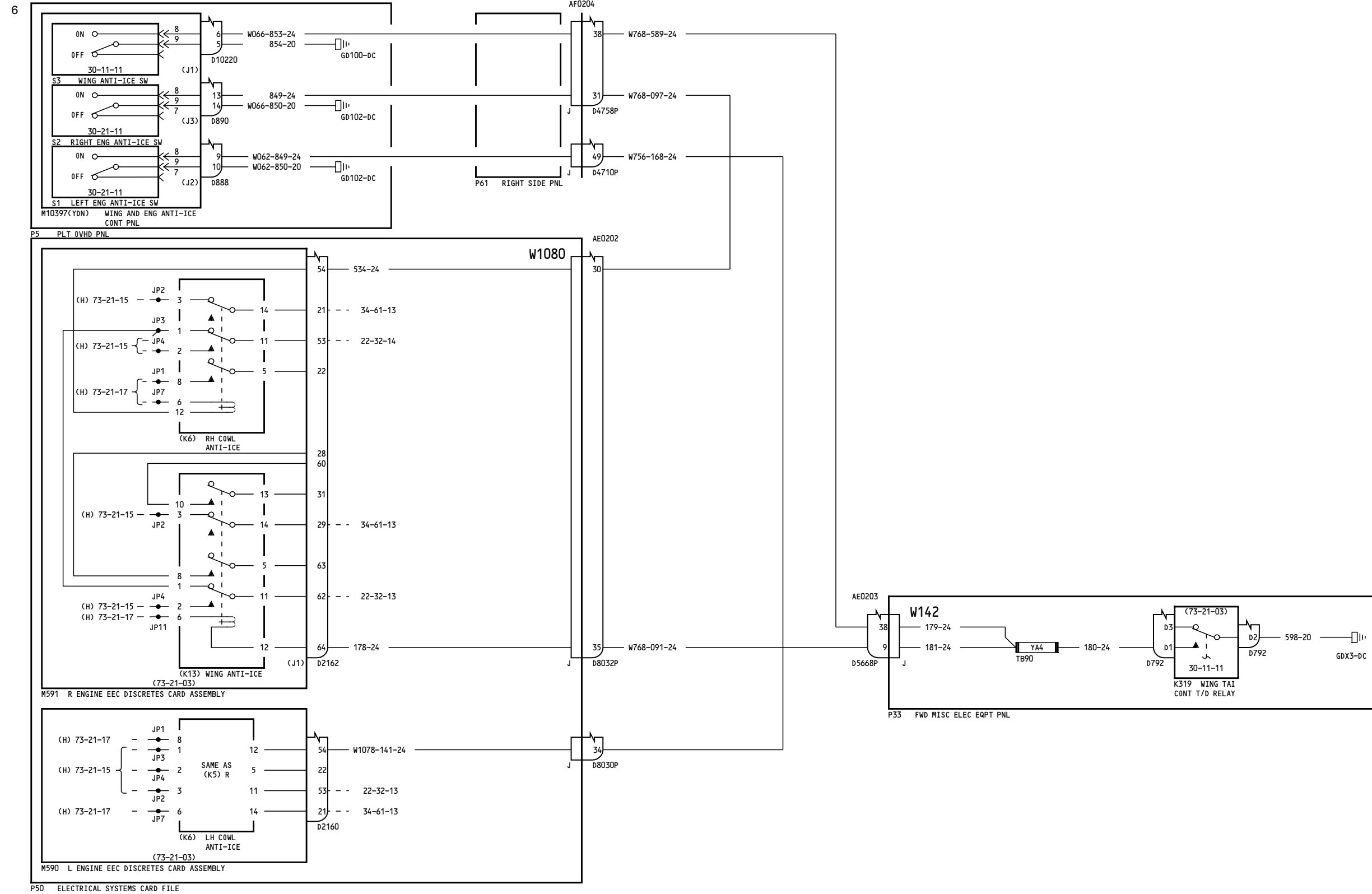

150-154, 275-299

ELECTRONIC ENGINE CONTROL ANTI-ICE DISCRETES

73-21-16

Page 2

D280T132

Jan 21/2005

73-21-16

Page 2

Jan 21/2005

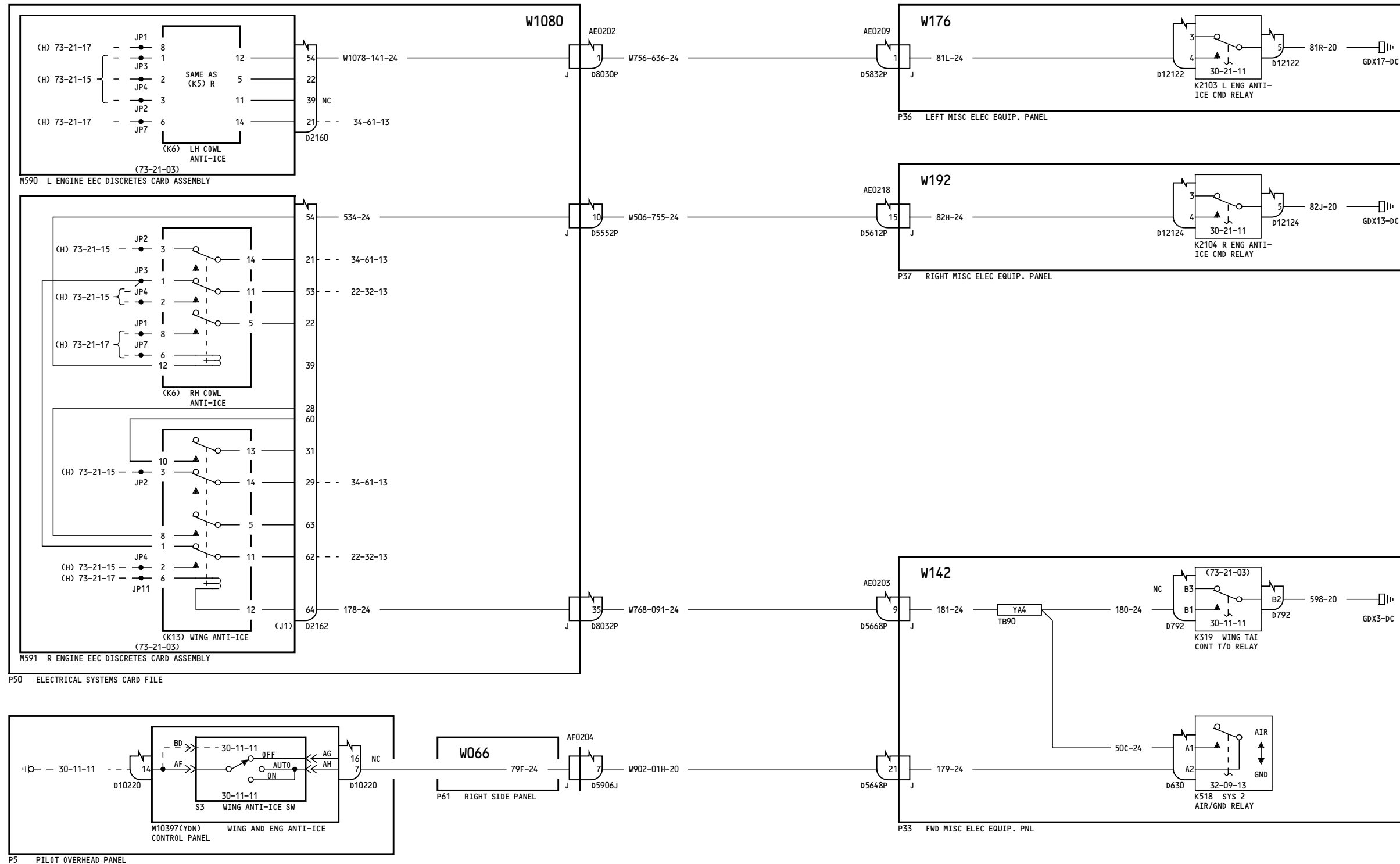

150-154

ELECTRONIC ENGINE CONTROL ANTI-ICE DISCRETES

D280T132

73-21-16

Page 2.1

Jan 21/2005

Incorporates
 30-0017

73-21-16

Page 2.1

Jan 21/2005

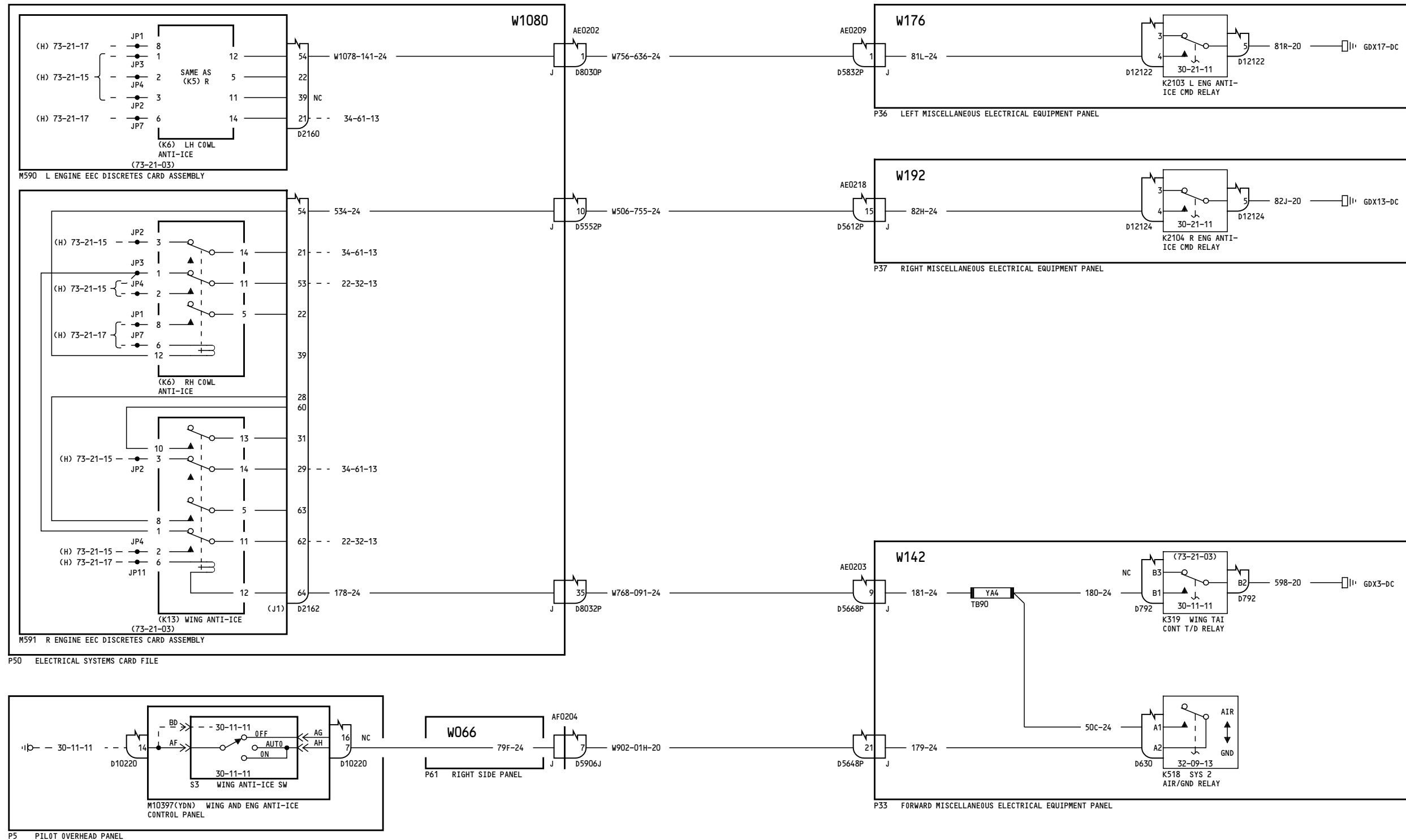

155-199

ELECTRONIC ENGINE CONTROL ANTI-ICE DISCRETES

73-21-16

Page 3

Jan 21/2005

D280T132

73-21-16

Page 3

Jan 21/2005

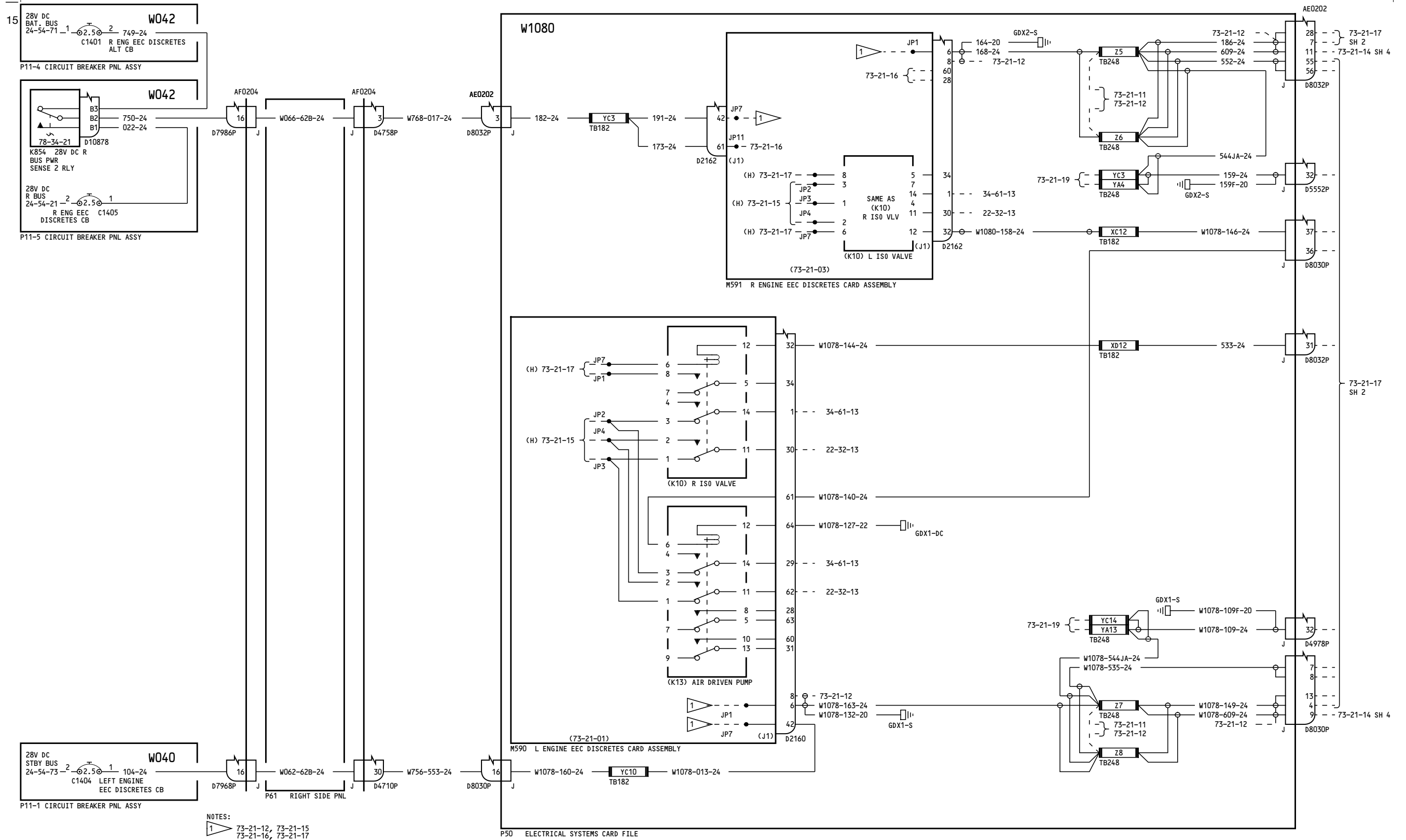

NOTES:
 1 73-21-12, 73-21-15
 73-21-16, 73-21-17

ALL

ELECTRONIC ENGINE CONTROL DISCRETES

D280T132

73-21-17

Page 1
 Sheet 1
 Jan 21/2005

73-21-17

Page 1
 Sheet 1
 Jan 21/2005

-E
15

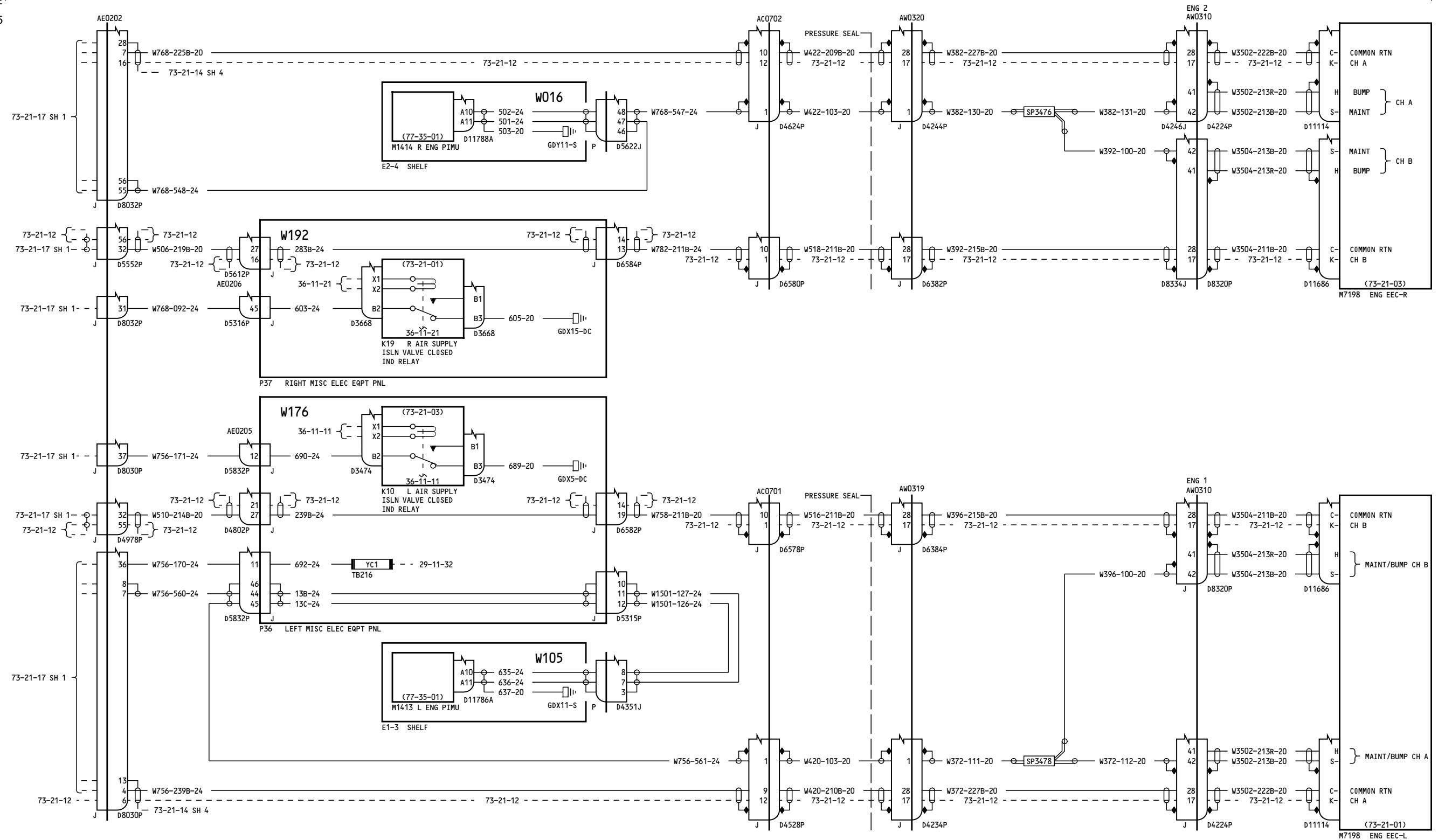

NOTES:
SHIELD PIGTAIL TO DISCONNECT BACKSHELL 2 INCH MAXIMUM

ALL	ELECTRONIC ENGINE CONTROL DISCRETES
	73-21-17
	Page 1 Sheet 2 Jan 21/2005
	D280T132

73-21-17

Page 1
Sheet 2
Jan 21/2005

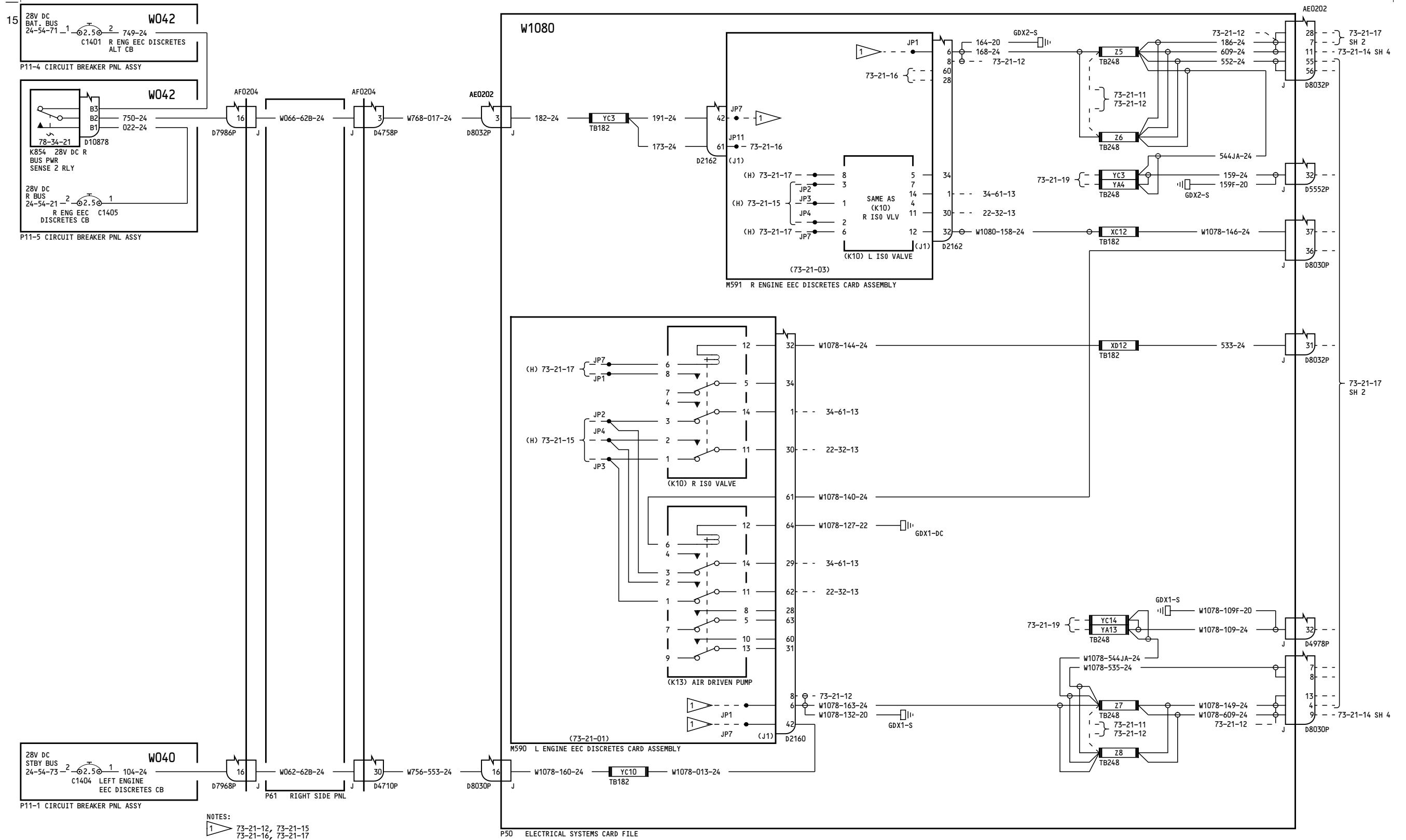

NOTES:
 1 73-21-12, 73-21-15
 73-21-16, 73-21-17

050

ELECTRONIC ENGINE CONTROL DISCRETES

73-21-17

Page 1.1
Sheet 1
Jan 21/2005

D280T132

73-21-17

Page 1.1
Sheet 1
Jan 21/2005

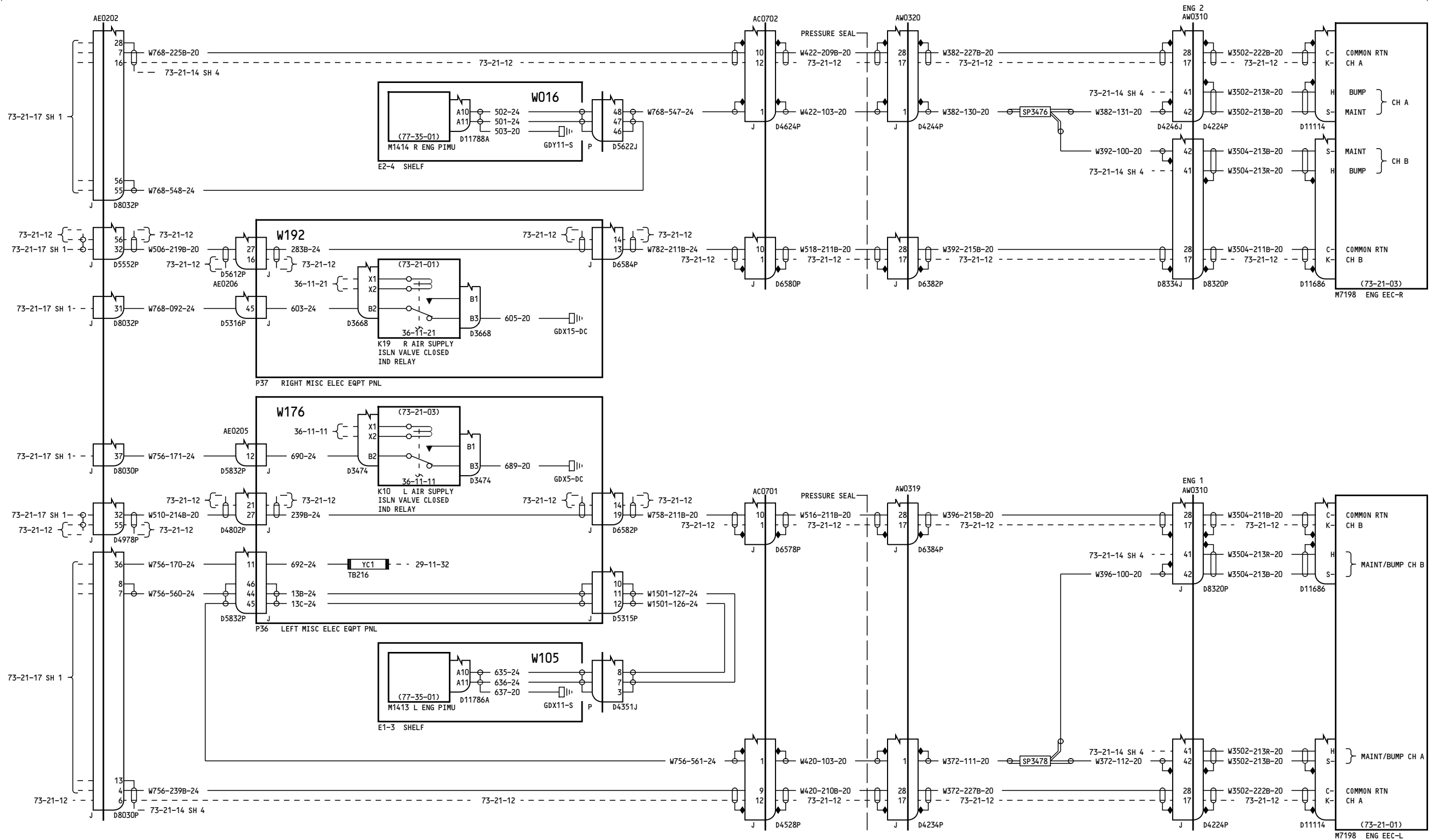

NOTES:
SHIELD PIGTAIL TO DISCONNECT BACKSHELL 2 INCH MAXIMUM

050

ELECTRONIC ENGINE CONTROL DISCRETES

73-21-17

Page 1.1
Sheet 2
Jan 21/2005

D280T132

Incorporates
72-0037, 72-0038

73-21-17

Page 1.1
Sheet 2
Jan 21/2005

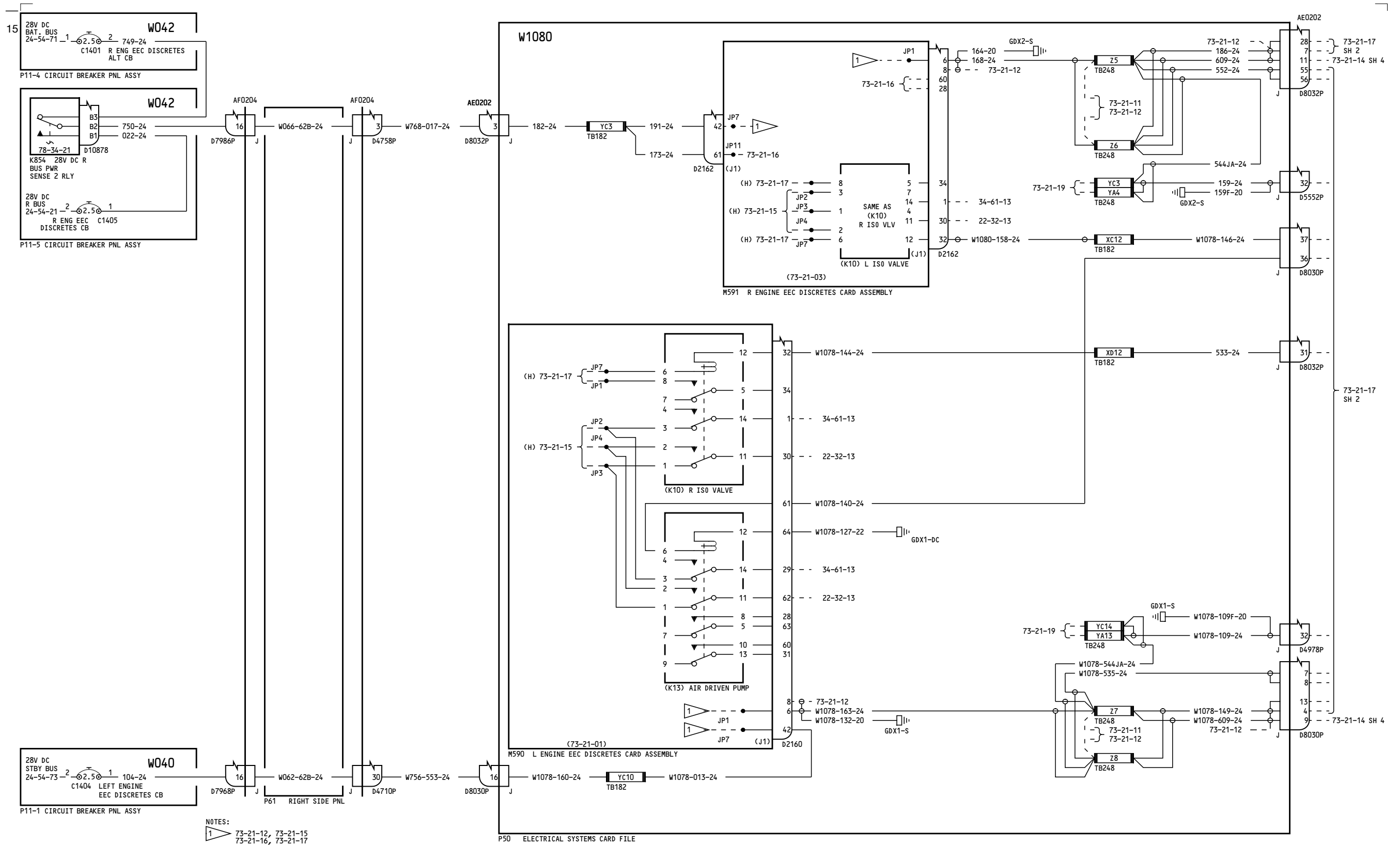

NOTES:
 1 73-21-12, 73-21-15
 73-21-16, 73-21-17

051

ELECTRONIC ENGINE CONTROL DISCRETES

D280T132

73-21-17

Page 1.2
 Sheet 1
 Jan 21/2005

73-21-17

Page 1.2
 Sheet 1
 Jan 21/2005

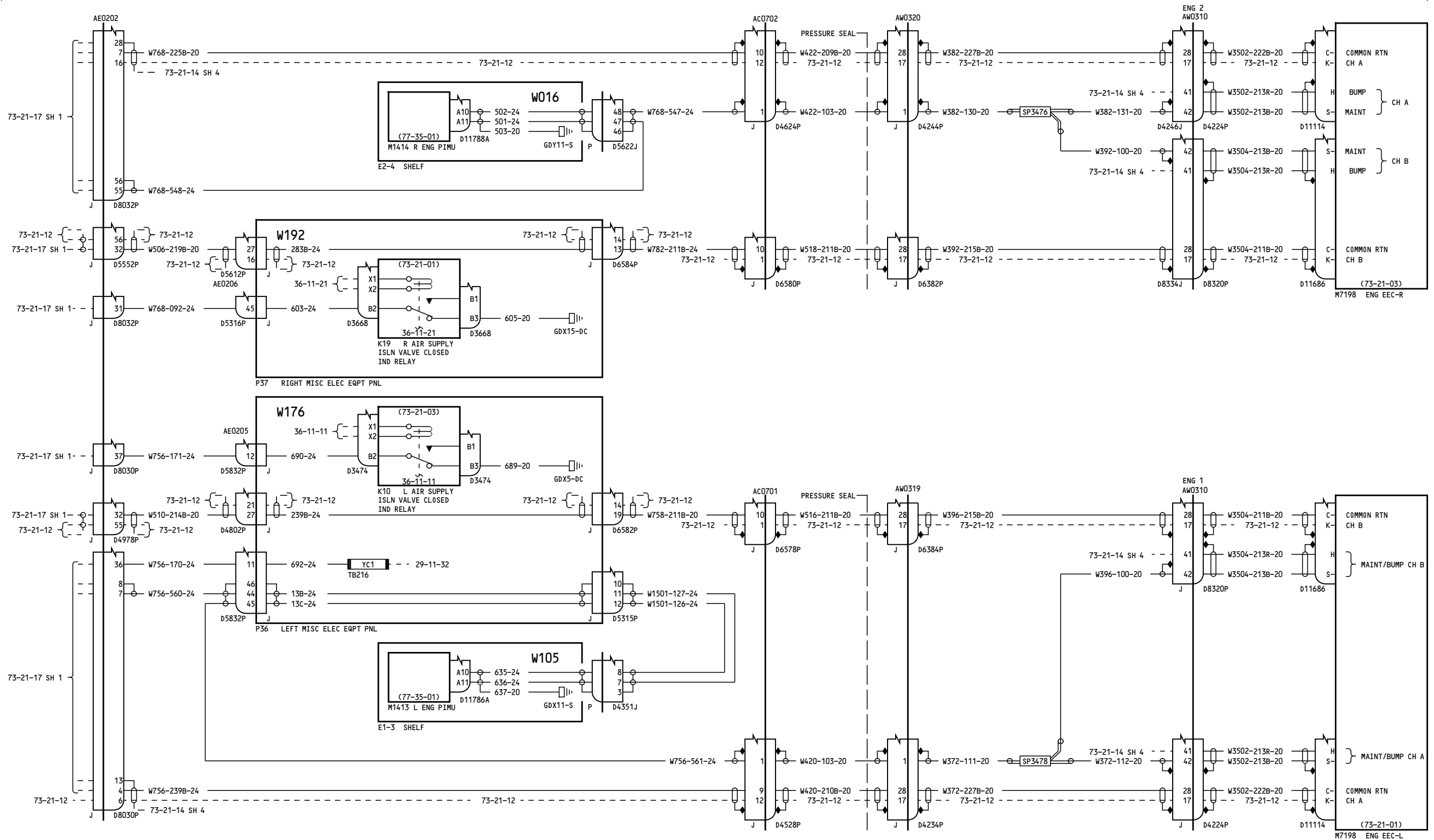

NOTES:
SHIELD PIGTAIL TO DISCONNECT BACKSHELL 2 INCH MAXIMUM

051

ELECTRONIC ENGINE CONTROL DISCRETES

73-21-17

Page 1.2
Sheet 2
Jan 21/2005

D280T132

Incorporates
72-0038

73-21-17

Page 1.2
Sheet 2
Jan 21/2005

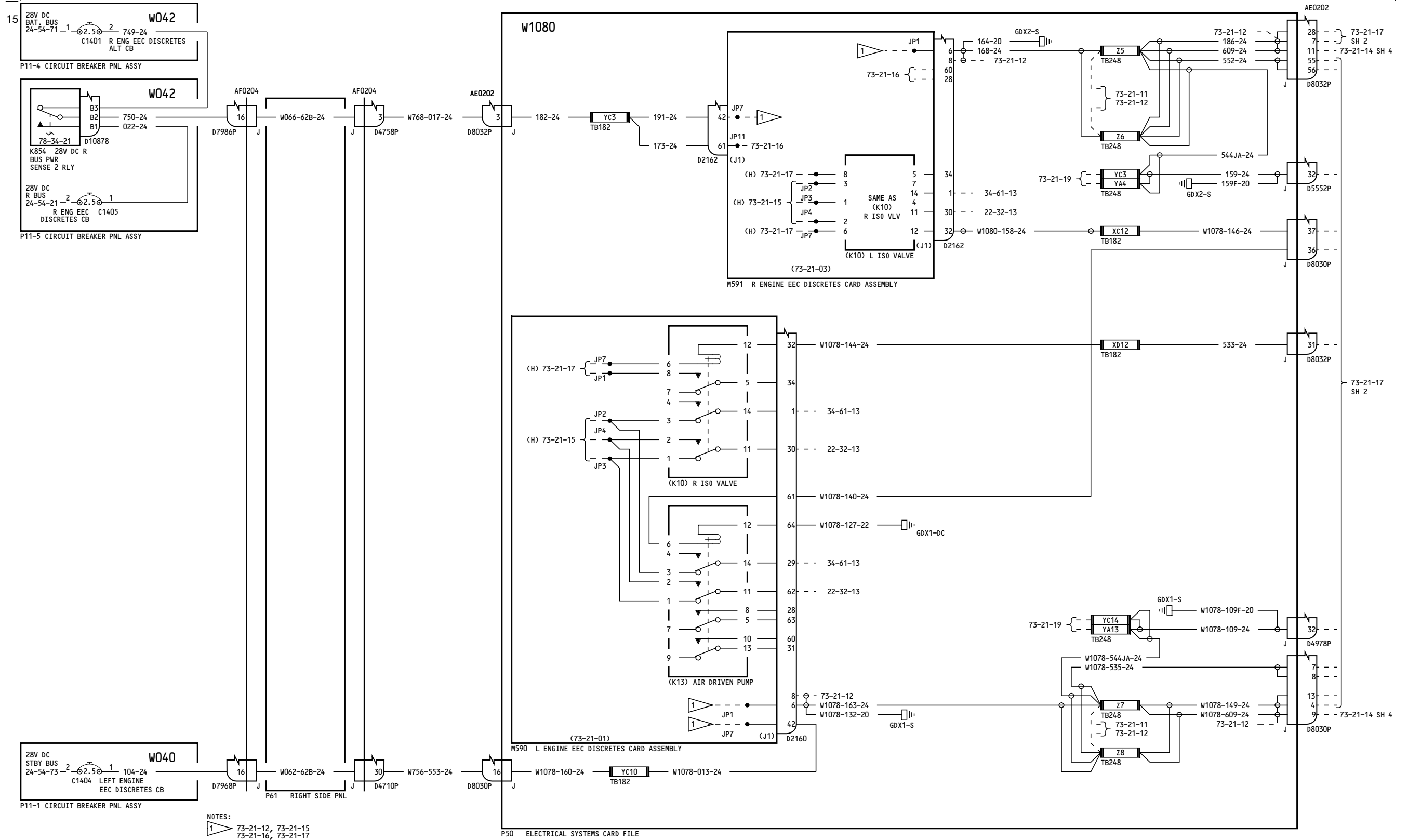

NOTES:
1 73-21-12, 73-21-15
73-21-16, 73-21-17

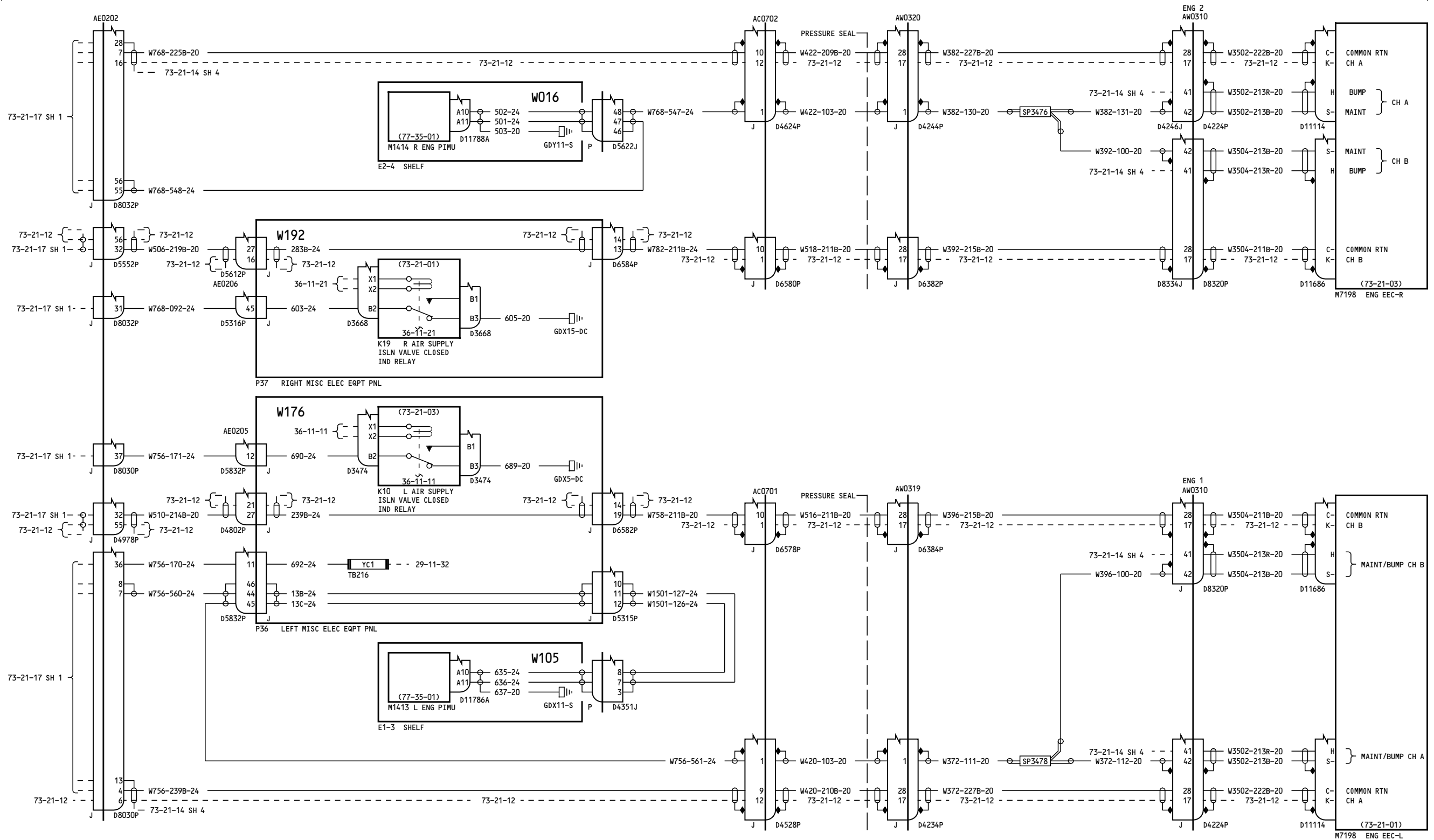

NOTES:
SHIELD PIGTAIL TO DISCONNECT BACKSHELL 2 INCH MAXIMUM

ELECTRONIC ENGINE CONTROL DISCRETES

D280T132

73-21-17

Page 1.3
Sheet 2
Jan 21/2005

Incorporates
71-0121

73-21-17

Page 1.3
Sheet 2
Jan 21/2005

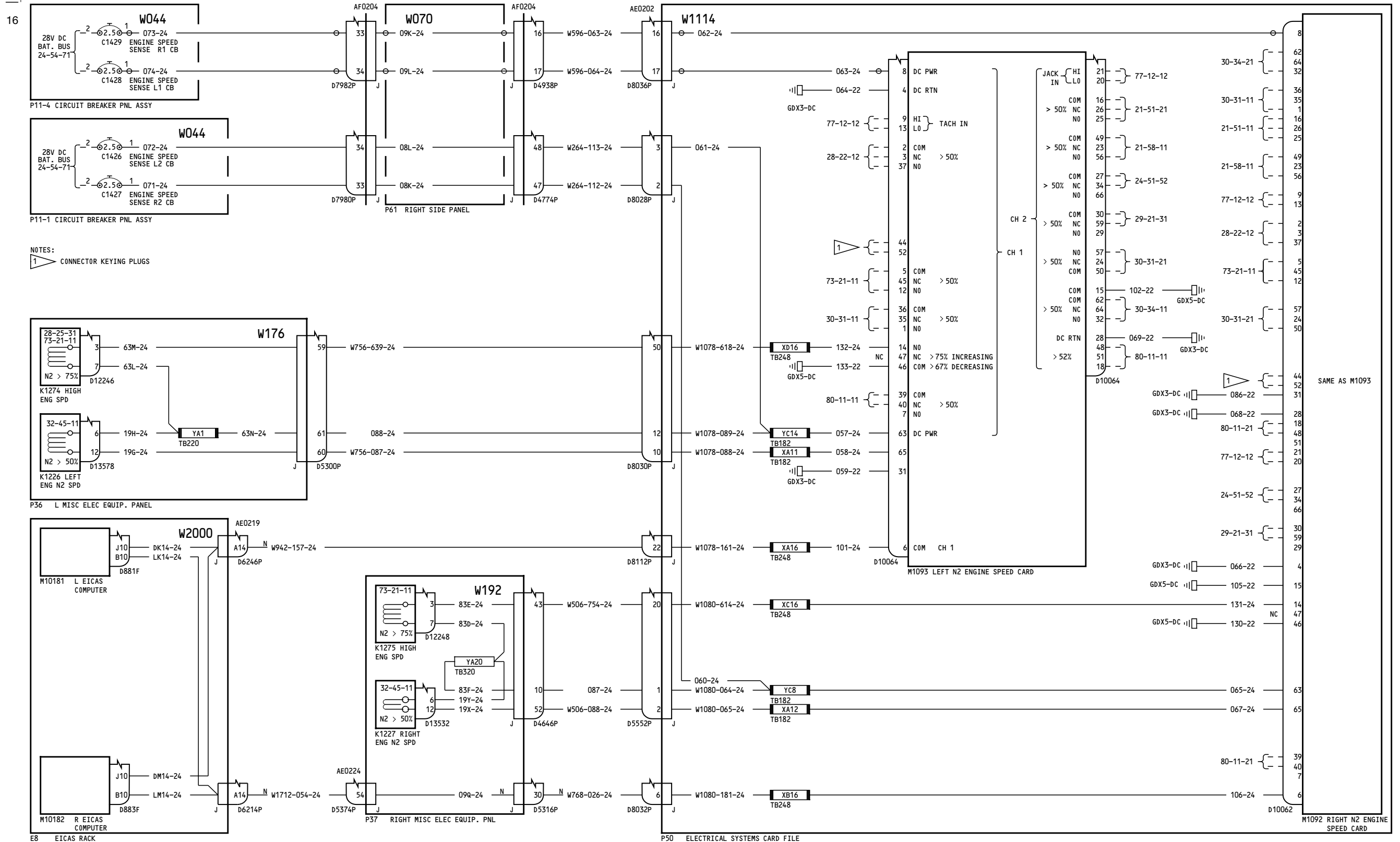

050-099, 277-299

ENGINE N2 DISCRETES

73-21-18

Page 1

Jan 21/2005

D280T132

73-21-18

Page 1

Jan 21/2005

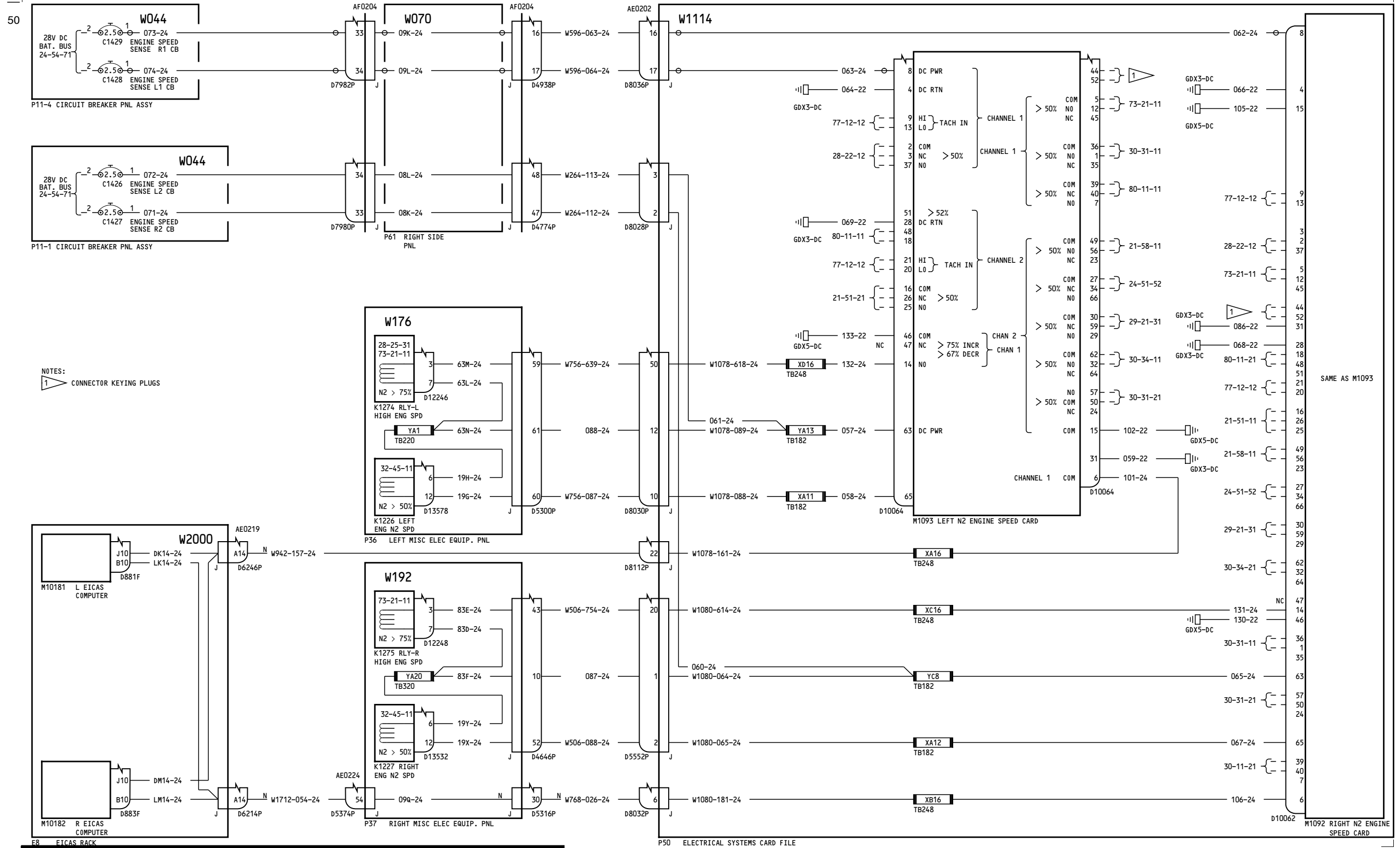

NOTES:
1 CONNECTOR KEYING PLUGS

150-154

ENGINE N2 DISCRETES
D280T132

73-21-18

Page 2.1

Jan 21/2005

Incorporates
76-0030 R02

73-21-18

Page 2.1

Jan 21/2005

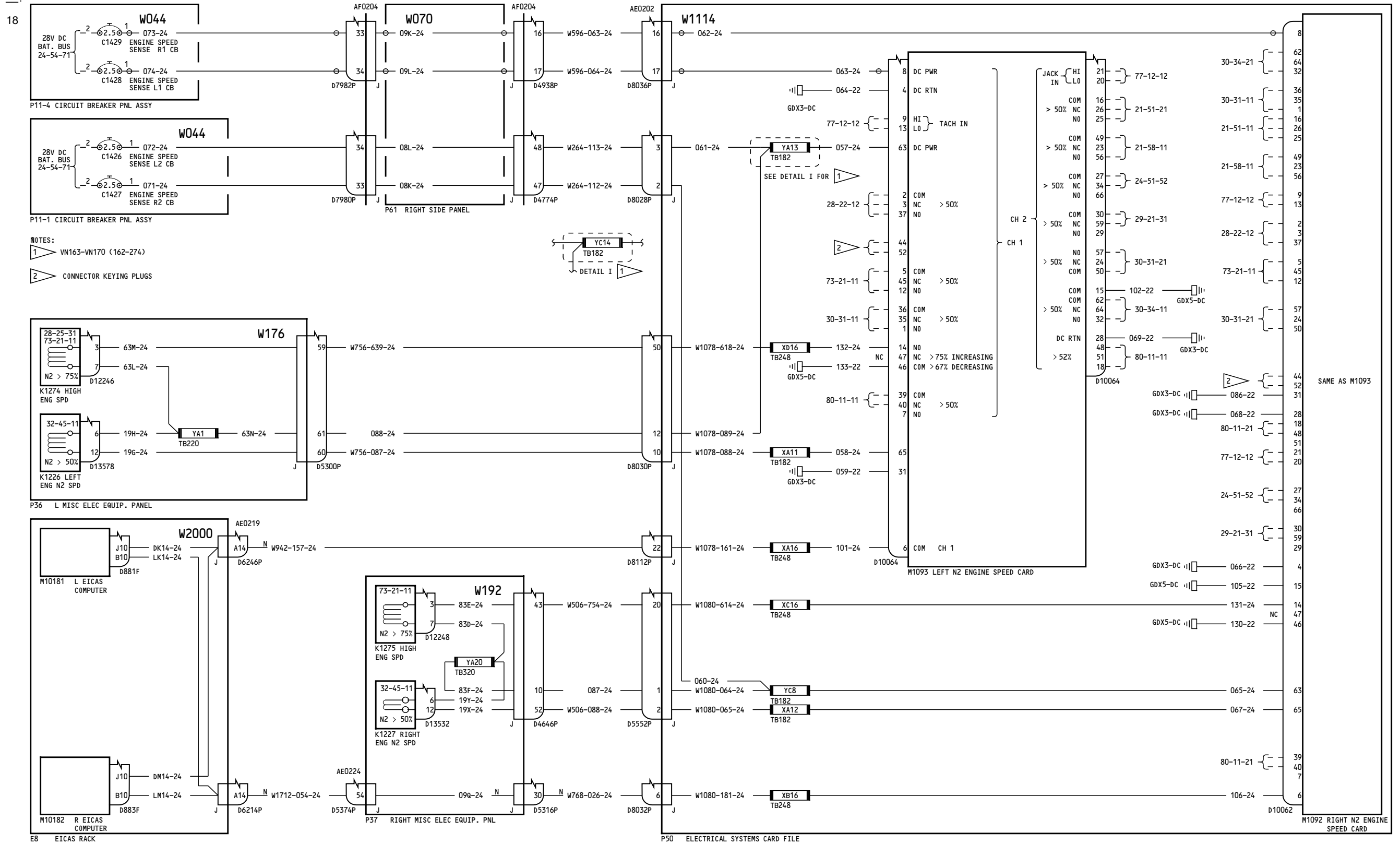

155-199

ENGINE N2 DISCRETES

73-21-18

Page 3

D280T132

Jan 21/2005

73-21-18

Page 3

Jan 21/2005

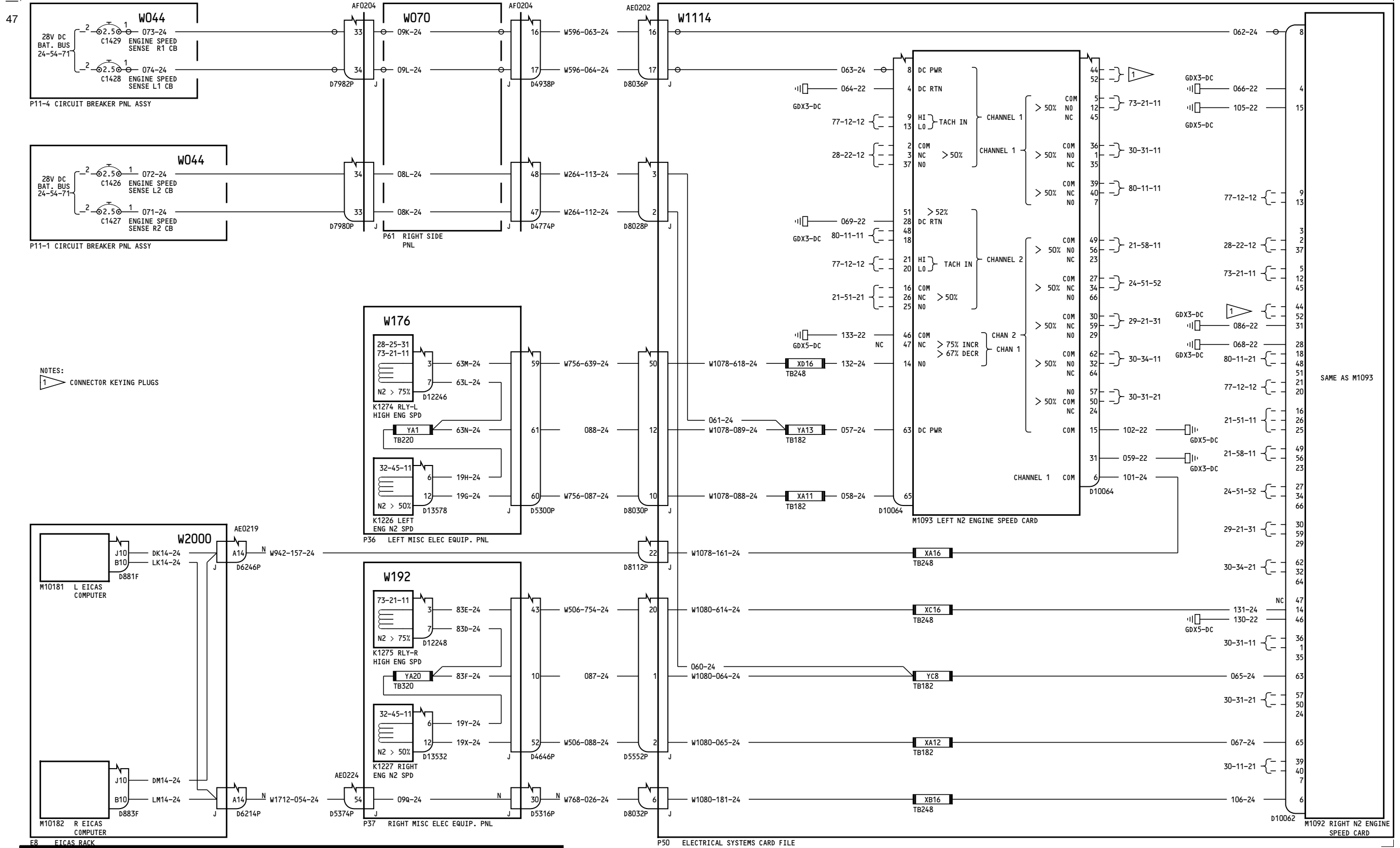

NOTES:
1 CONNECTOR KEYING PLUGS

SAME AS M1093

275-276

ENGINE N2 DISCRETES
D280T132

73-21-18

Page 4.1
Jan 21/2005

Incorporates
76-0026

73-21-18

Page 4.1
Jan 21/2005

-A
102

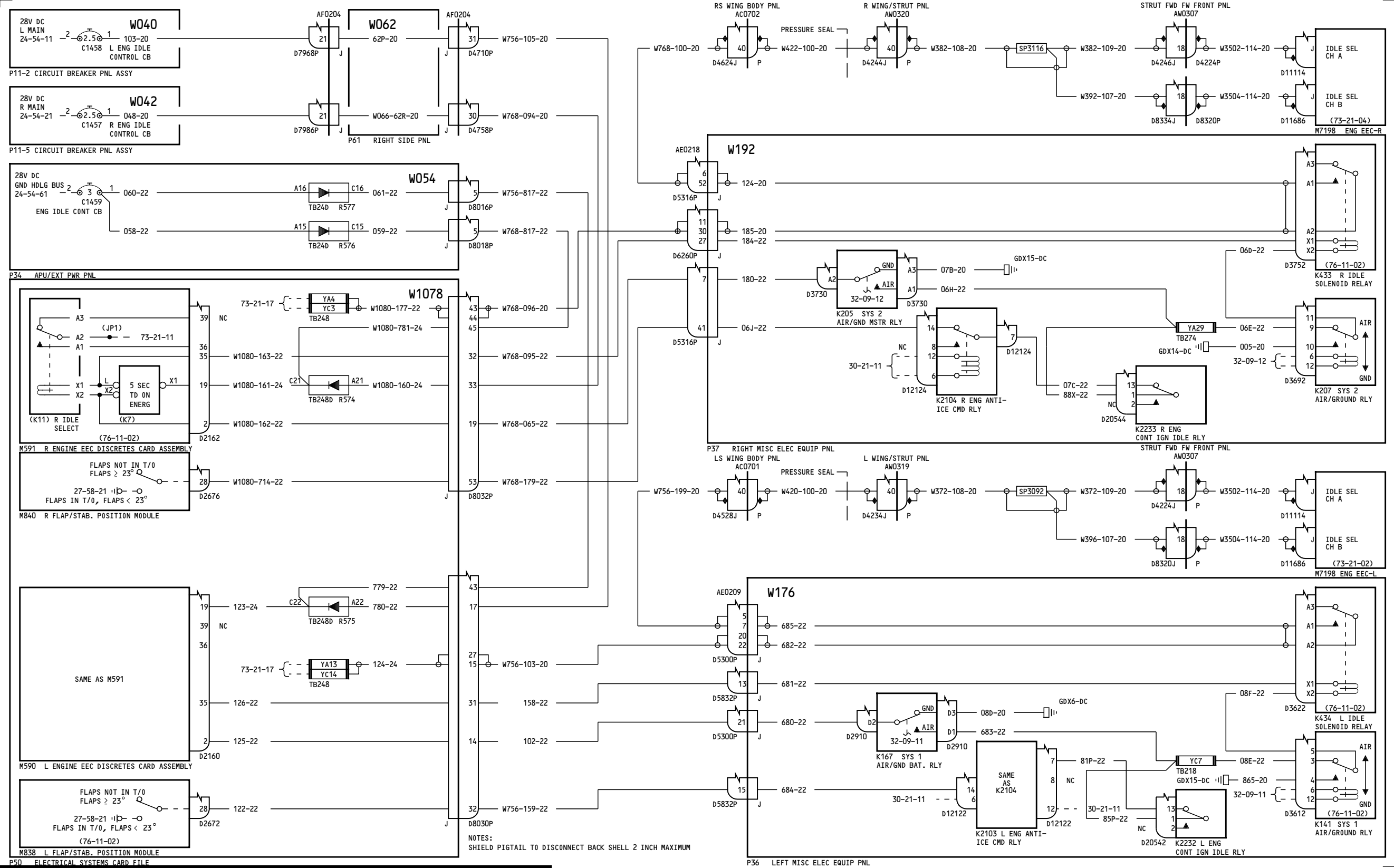

P50 ELECTRICAL SYSTEMS CARD FILE
050, 155-167

FLIGHT/GROUND IDLE

D280T132

73-21-19
Page 1.1
Jan 21/2005

Incorporates
73-0044 R01

73-21-19
Page 1.1
Jan 21/2005

BOEING PROPRIETARY - Copyright © - Unpublished Work - See title page for details.

109

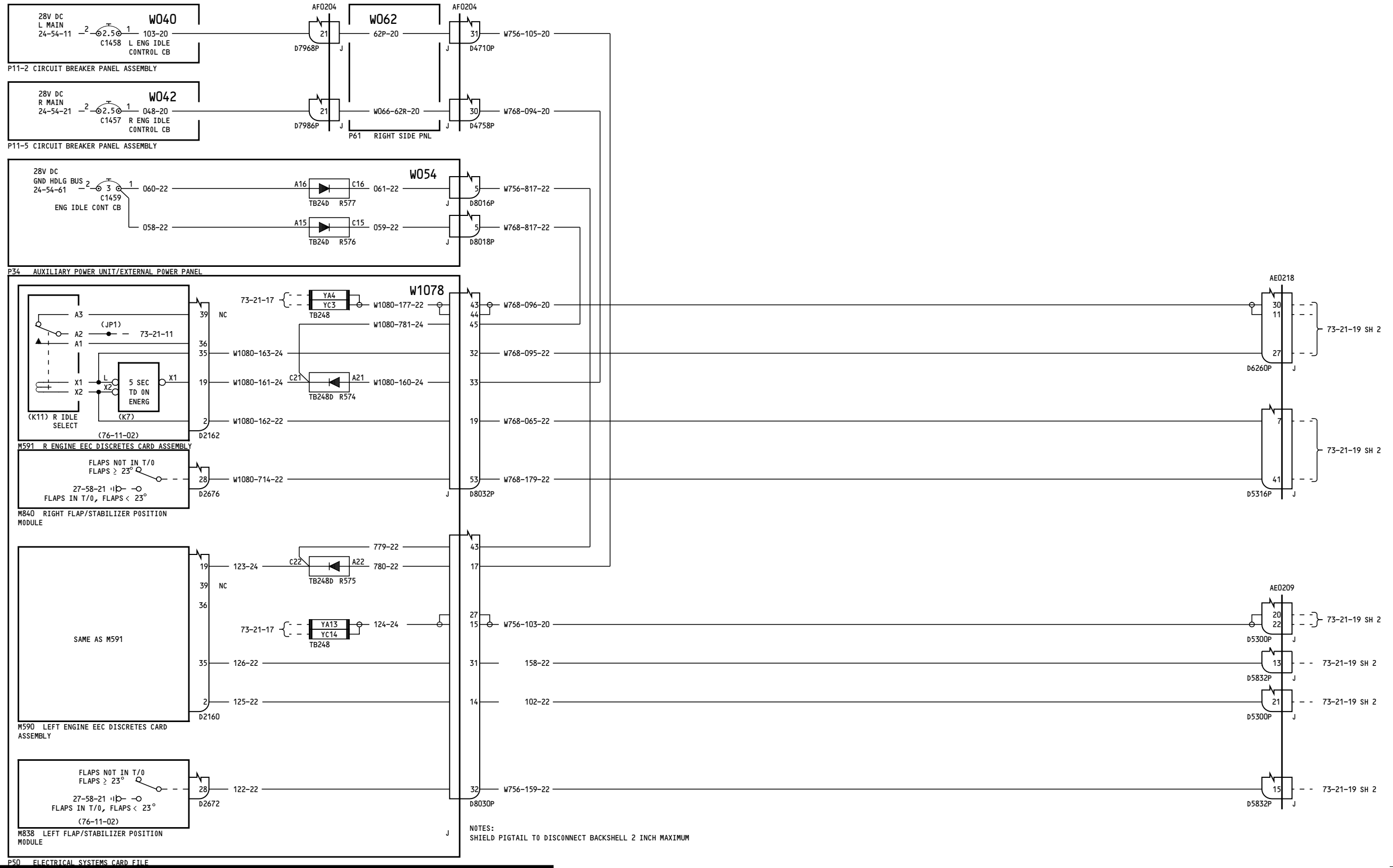

051

FLIGHT/GROUND IDLE

D280T132

73-21-19

Page 2.1
Sheet 1
Jan 21/2005

Incorporates
73A0033

73-21-19

Page 2.1
Sheet 1
Jan 21/2005

48

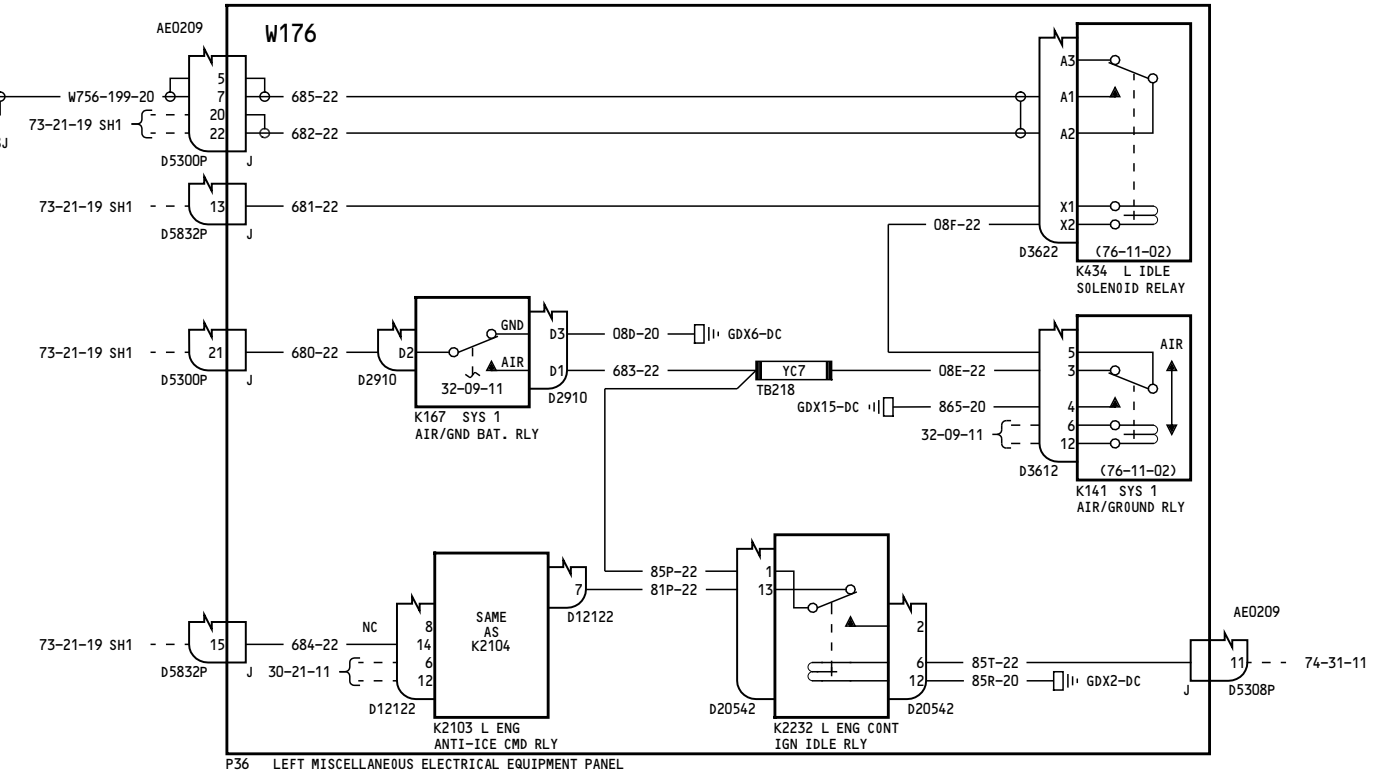
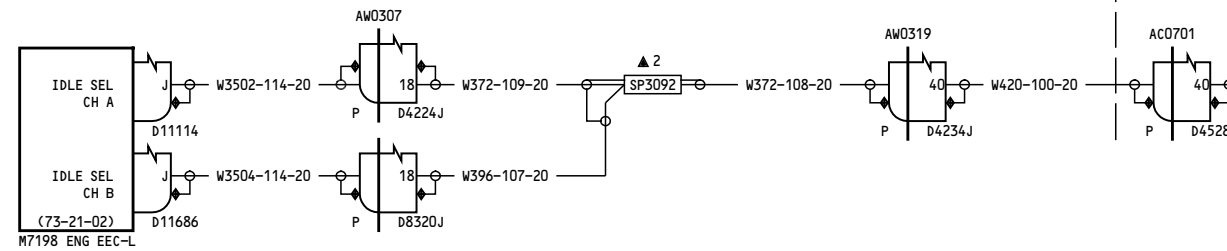
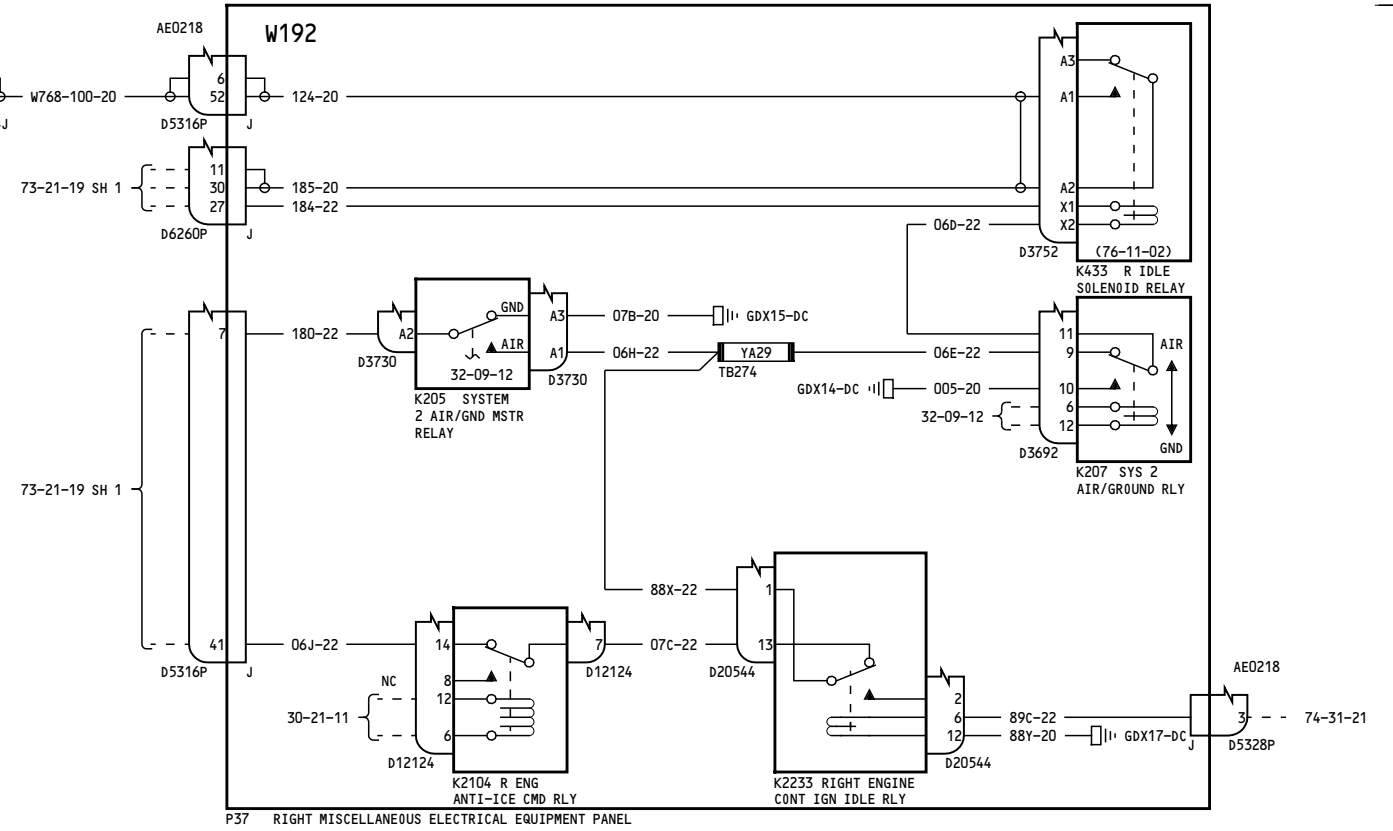
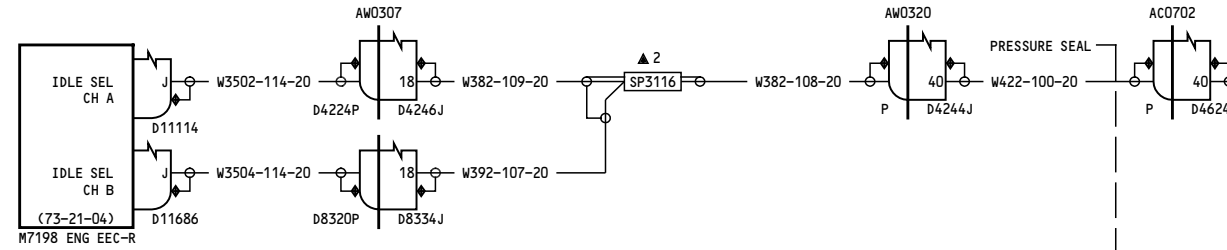

NOTES:
SHIELD PIGTAIL TO DISCONNECT BACKSHELL 2 INCH MAXIMUM

051

FLIGHT/GROUND IDLE

D280T132

73-21-19

Page 2.1
Sheet 2
Jan 21/2005

73-21-19

Page 2.1
Sheet 2
Jan 21/2005

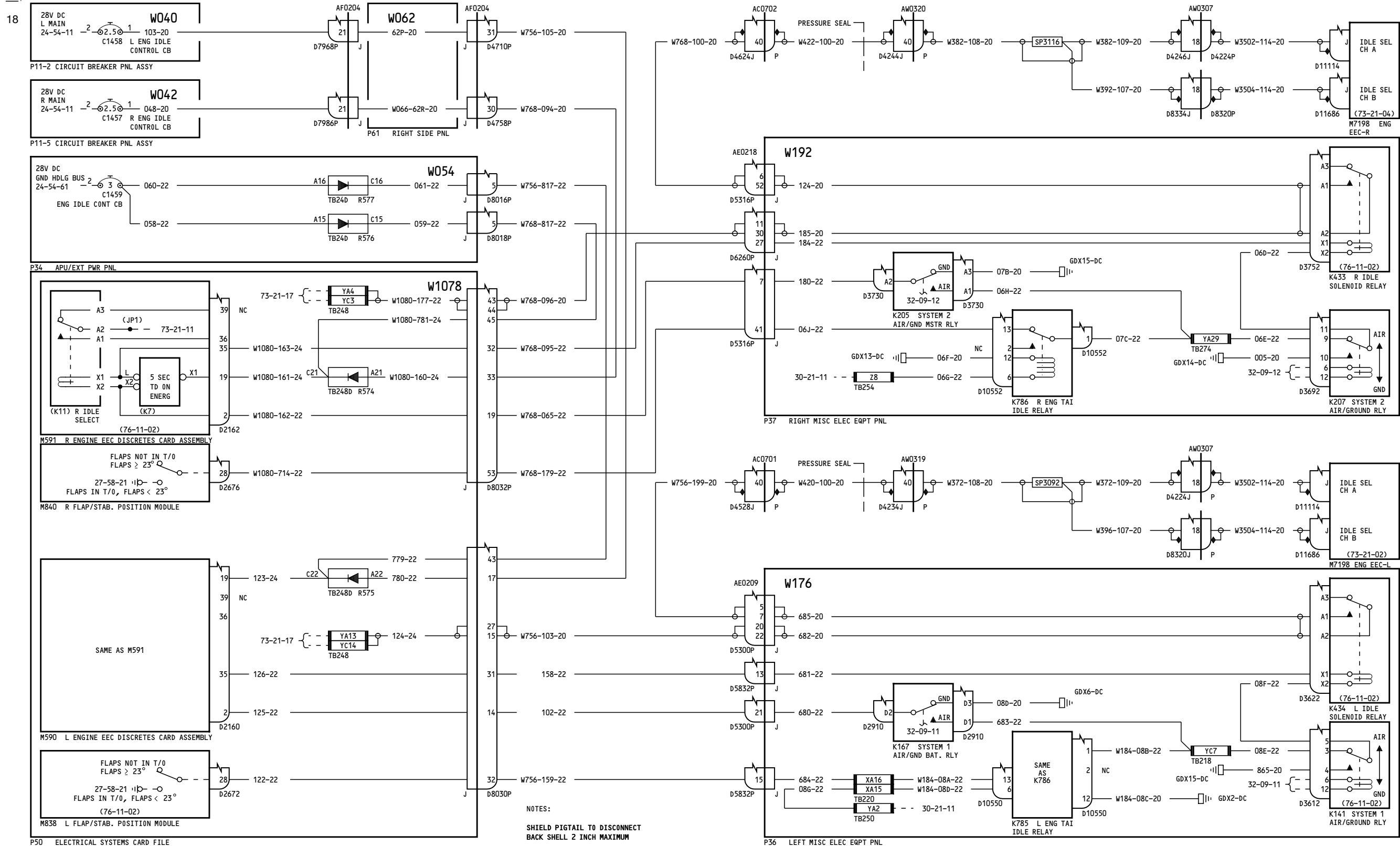

103

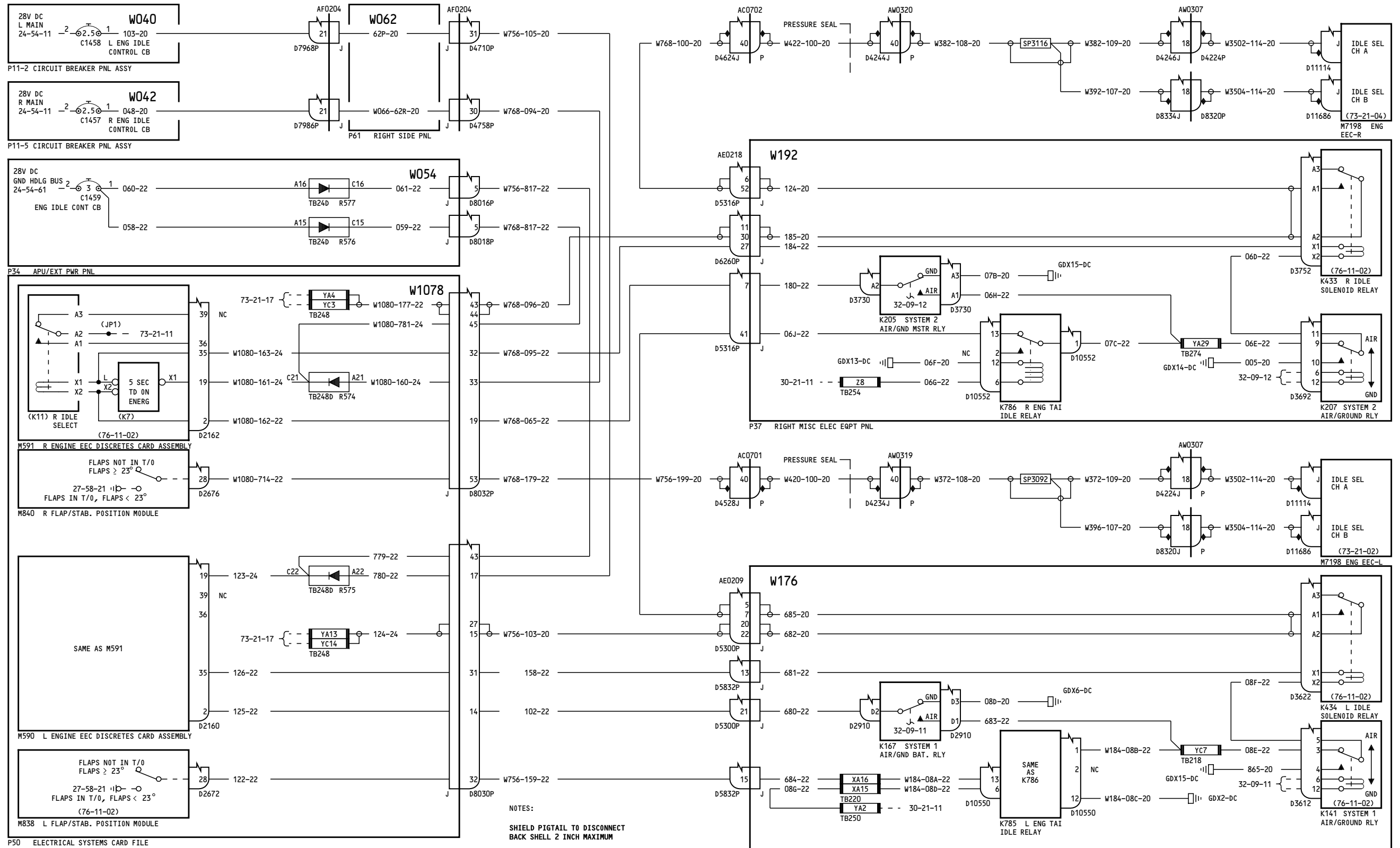

150-154

FLIGHT/GROUND IDLE

73-21-19

Page 3.1

Jan 21/2005

D280T132

Incorporates
 30-0017
 73-0044 R01

73-21-19

Page 3.1

Jan 21/2005

-A
107

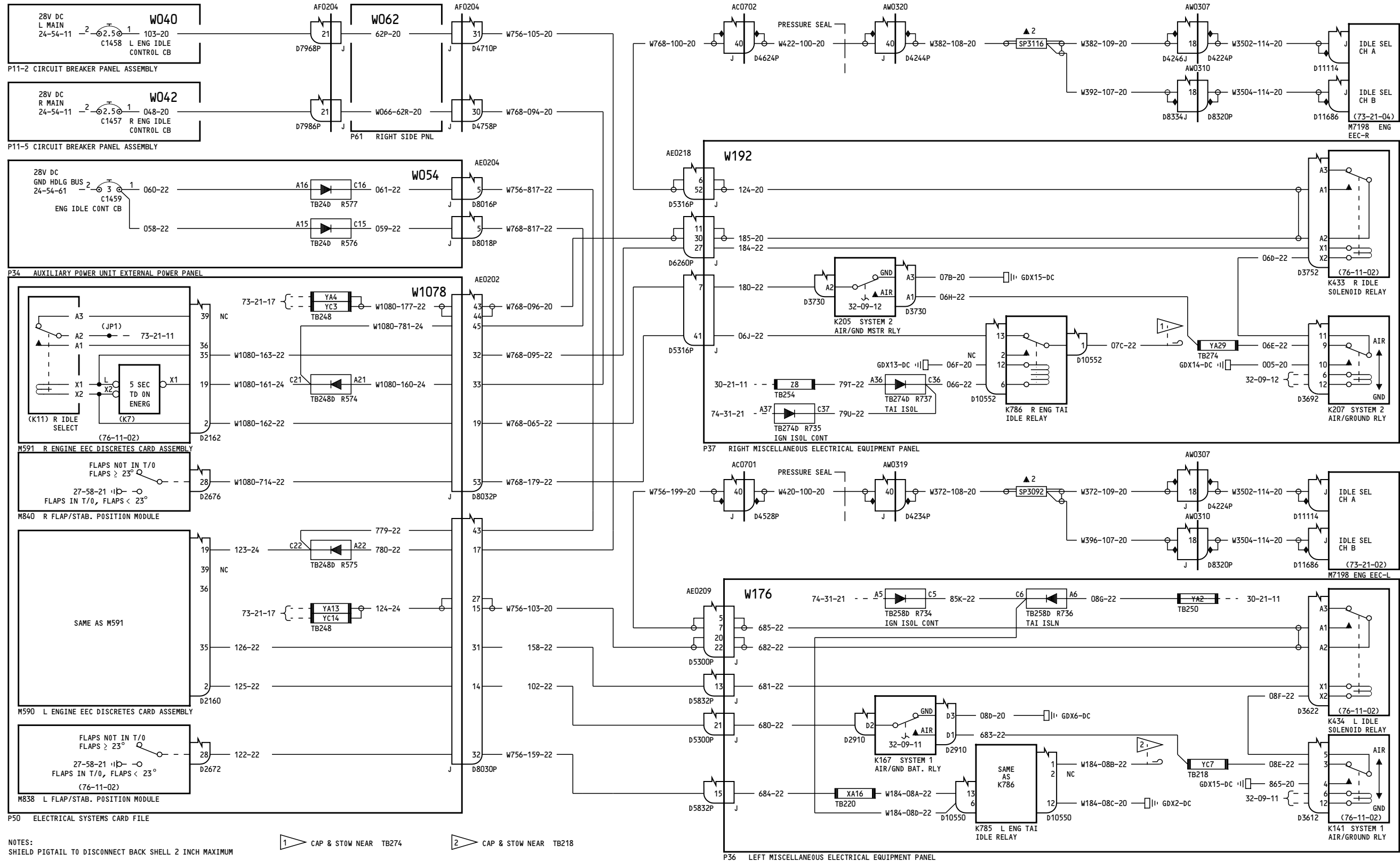

NOTES:
SHIELD PIGTAIL TO DISCONNECT BACK SHELL 2 INCH MAXIMUM

1 CAP & STOW NEAR TB274
2 CAP & STOW NEAR TB218

275-276

FLIGHT/GROUND IDLE

D280T132

73-21-19
Page 4.1
Jan 21/2005

Incorporates
73-0044 R01
73A0033

73-21-19
Page 4.1
Jan 21/2005

-A
108

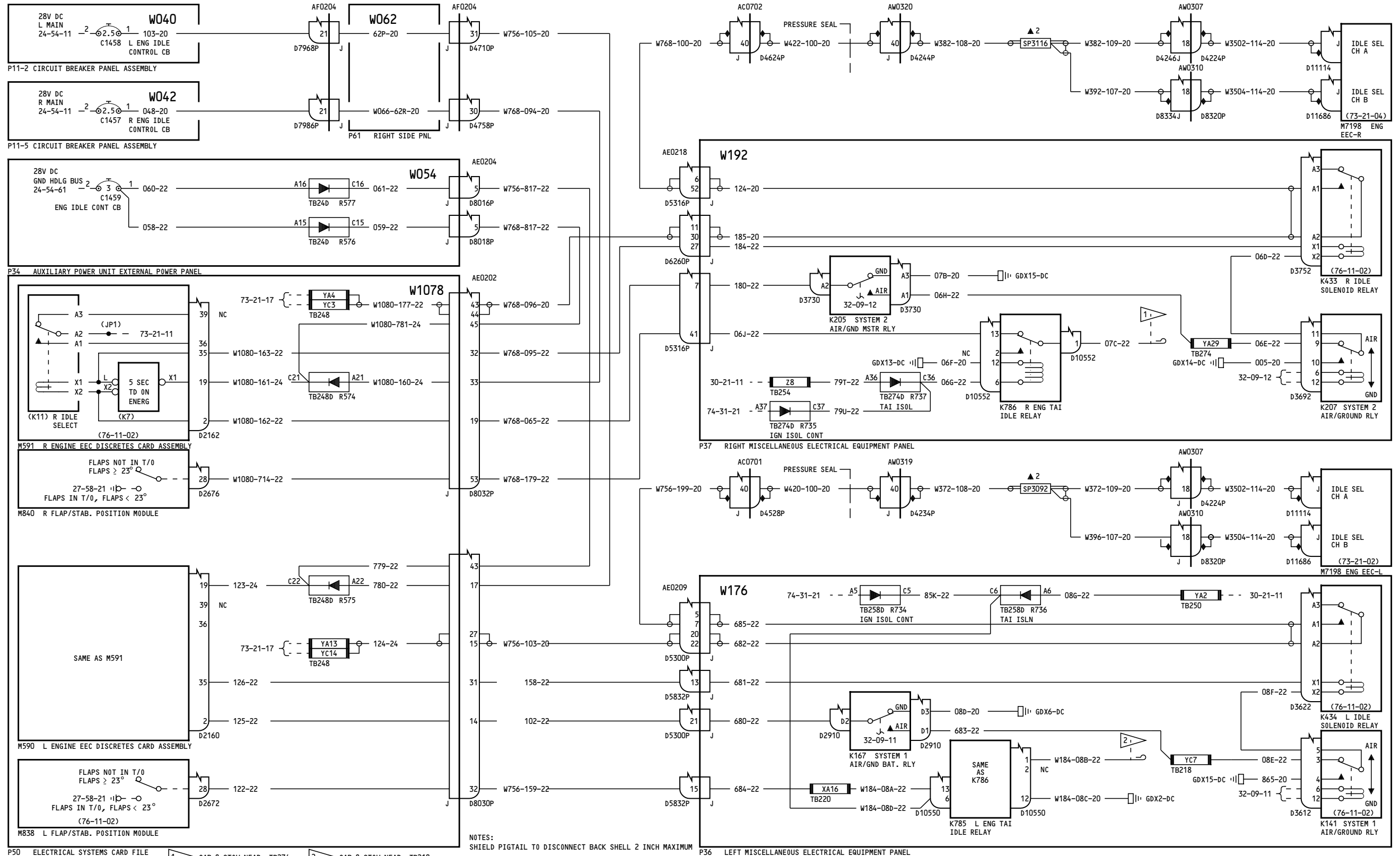

277-280

FLIGHT/GROUND IDLE

D280T132

73-21-19

Page 5.1

Jan 21/2005

Incorporates
73-0044 R01

73-21-19

Page 5.1

Jan 21/2005

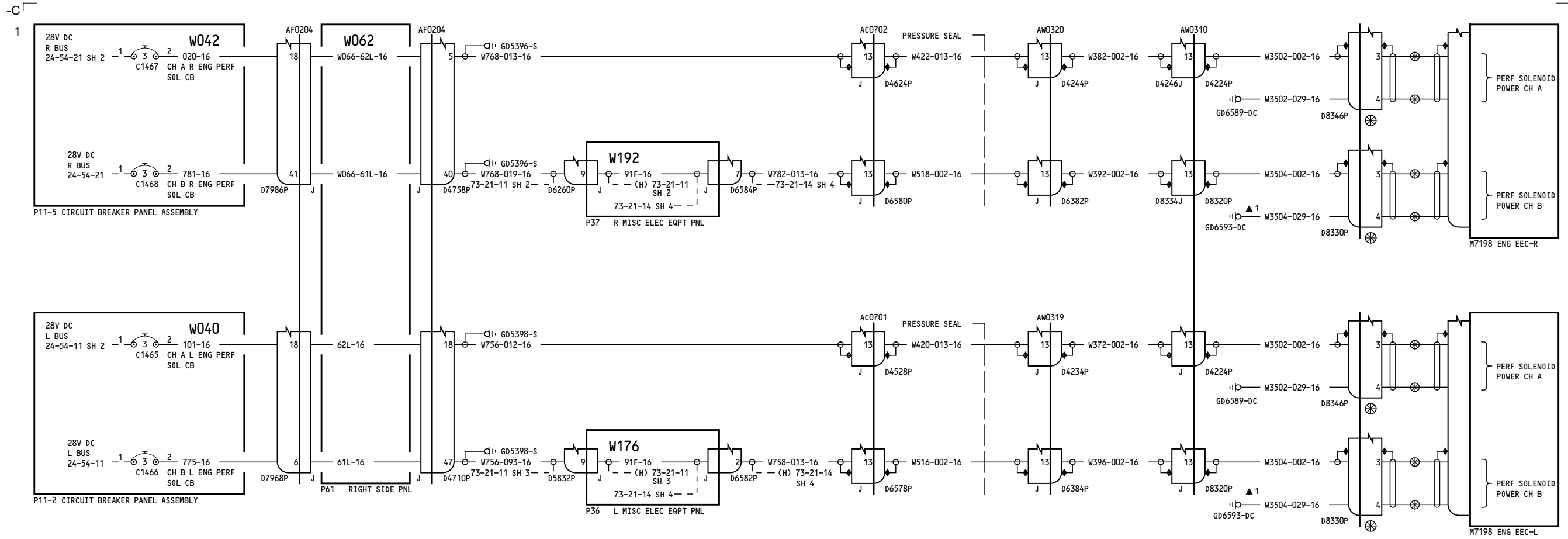

NOTES:
SHIELD PIGTAIL TO DISCONNECT
BACK SHELL 2 INCH MAXIMUM

050-099, 150-199, 277-299

**PERFORMANCE SOLENOID
POWER**

73-21-20

Page 1

D280T132

Jan 21/2005

73-21-20

Page 1

Jan 21/2005

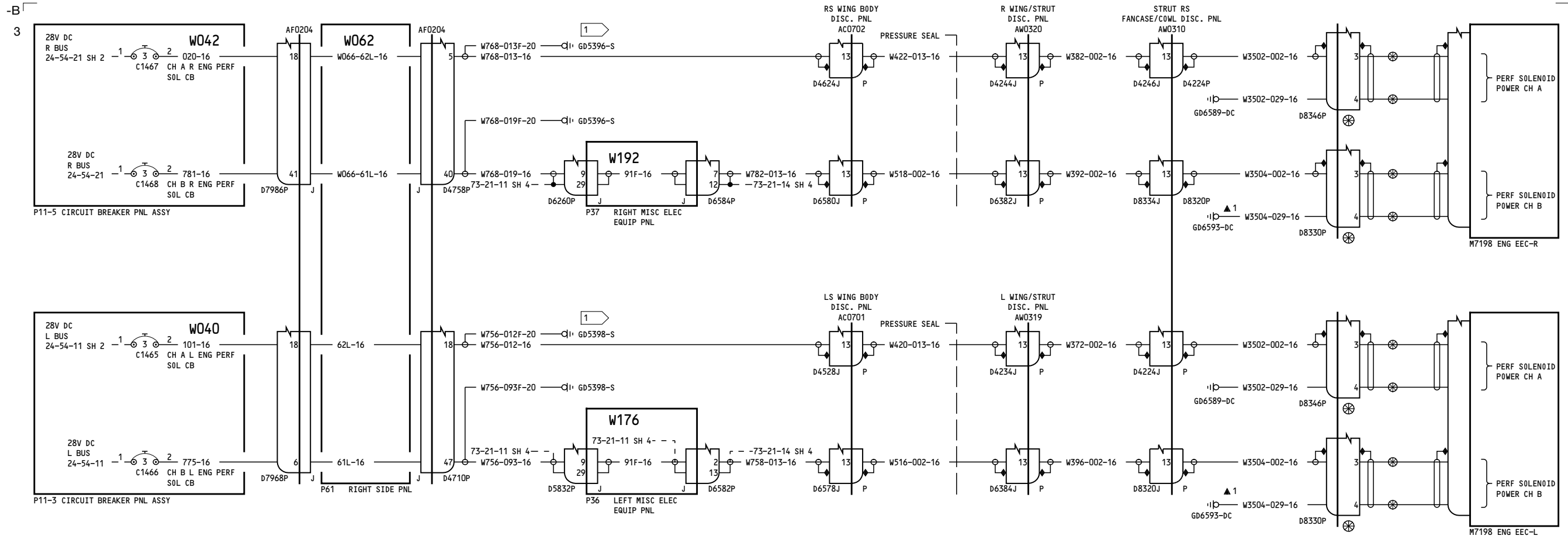

NOTES:
 SHIELD PIGTAIL TO DISCONNECT
 BACK SHELL 2 INCH MAXIMUM
 1 SHIELD PIGTAIL 6 INCH MAXIMUM

275-276

PERFORMANCE SOLENOID POWER

73-21-20

Page 2

D280T132

Jan 21/2005

73-21-20

Page 2

Jan 21/2005

-A
11

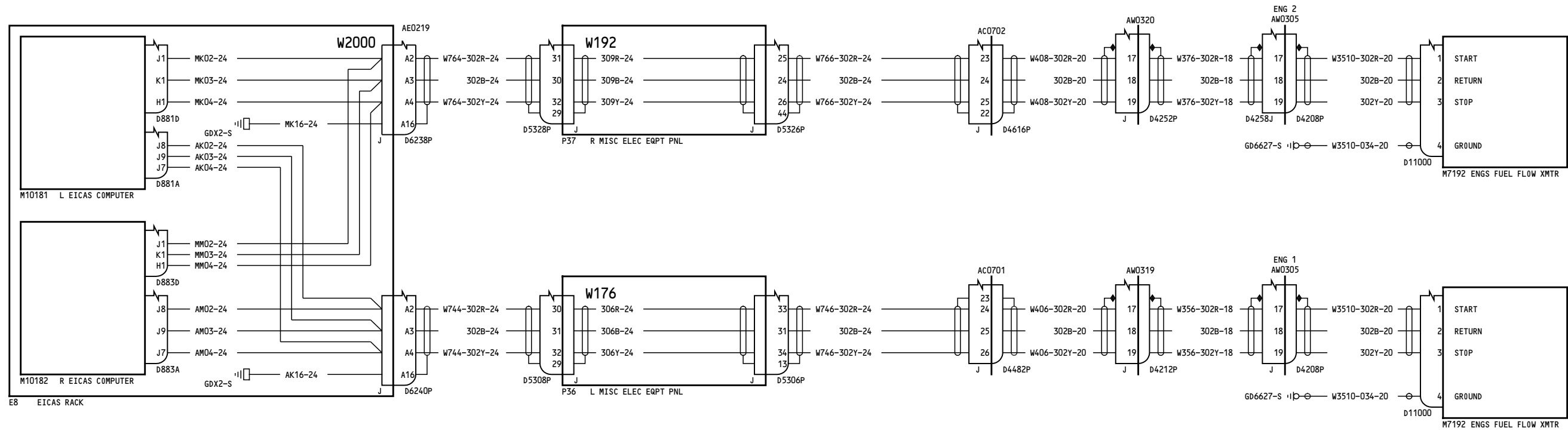

NOTES:
SHIELD PIGTAIL TO DISCONNECT
BACKSHELL 2 INCH MAXIMUM

ALL	<p align="center">FUEL FLOW INDICATING SYSTEM</p> <p align="center">D280T132</p>
-----	---

73-31-11

Page 1

Jan 21/2005

73-31-11

Page 1

Jan 21/2005

11

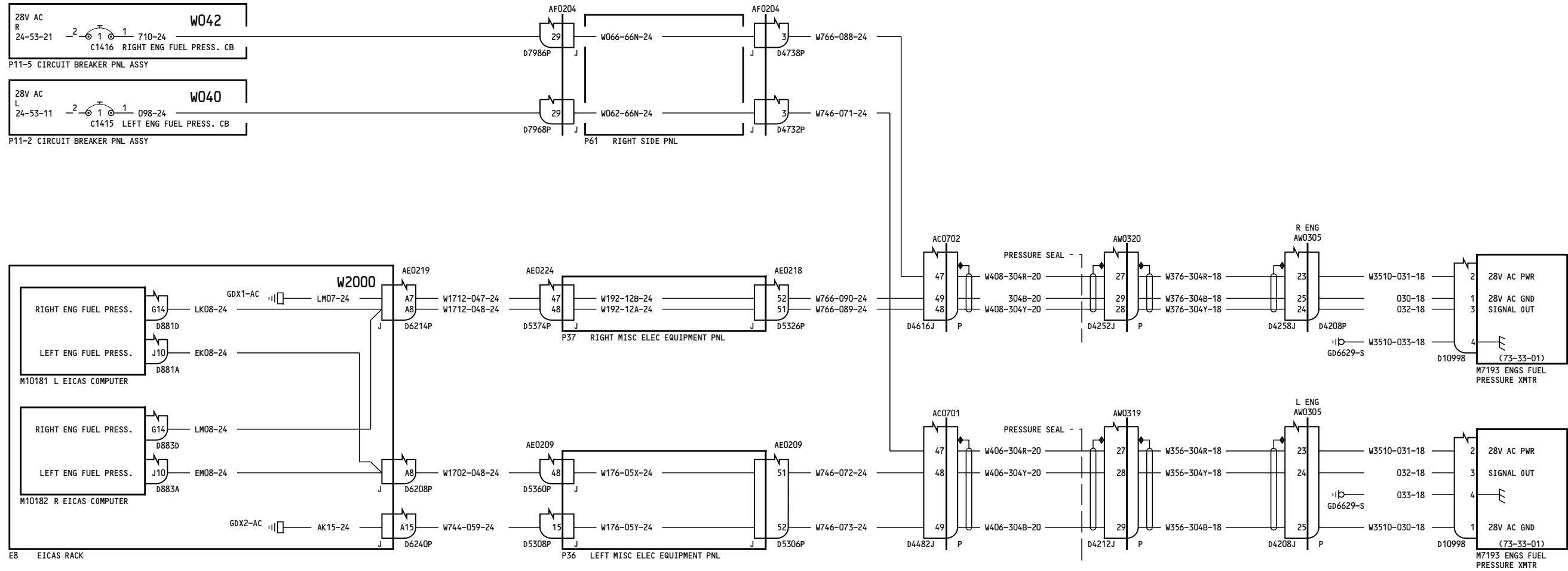

NOTES:
SHIELD PIGTAIL TO DISCONNECT BACKSHELL 2 INCH MAXIMUM

050-099, 150-157, 275-299

ENGINE FUEL PRESSURE INDICATION

D280T132

73-33-11

Page 1

Jan 21/2005

73-33-11

Page 1

Jan 21/2005

21

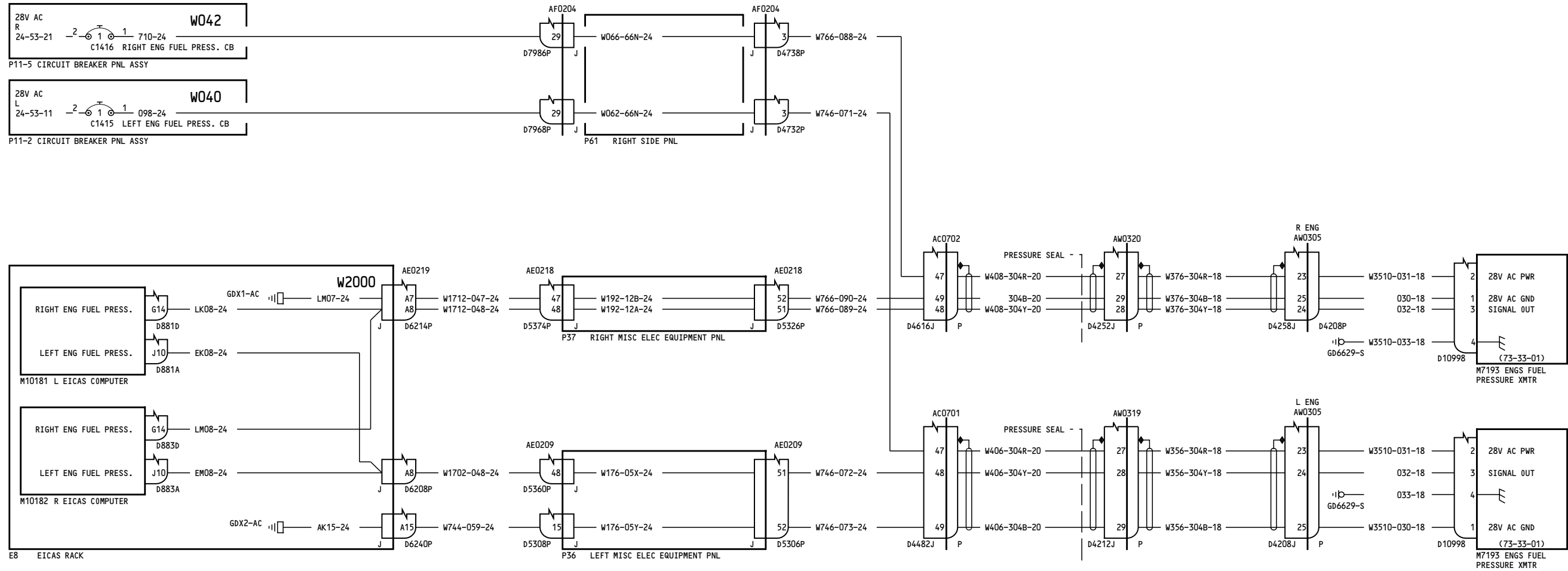

NOTES:
SHIELD PIGTAIL TO DISCONNECT BACKSHELL 2 INCH MAXIMUM

162-199

ENGINE FUEL PRESSURE INDICATION

D280T132

73-33-11

Page 2

Jan 21/2005

73-33-11

Page 2

Jan 21/2005

4

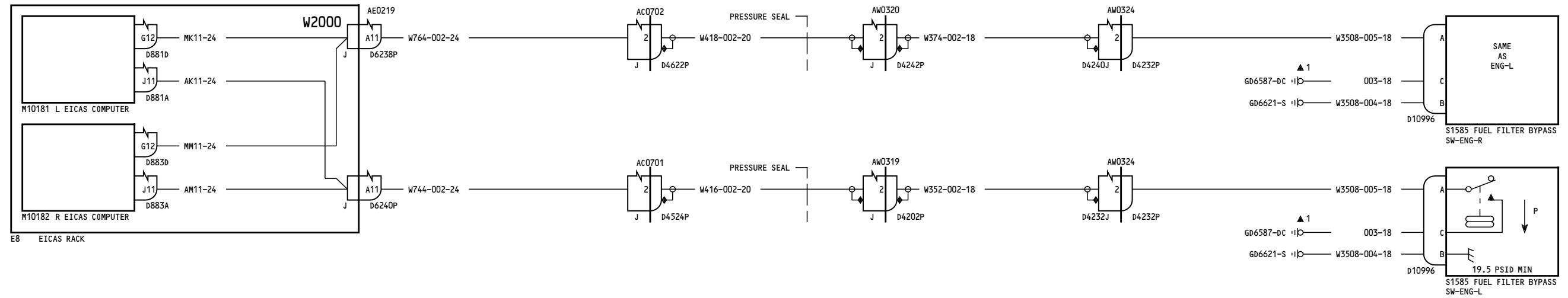

NOTES:
SHIELD PIGTAIL TO DISCONNECT
BACKSHELL 2 INCH MAXIMUM

ALL	<p align="center">ENGINE FUEL FILTER BYPASS WARNING</p> <p align="center">D280T132</p>
-----	---

73-34-11

Page 1

Jan 21/2005

73-34-11

Page 1

Jan 21/2005

TABLE 1
CONDUCTIVE RECEPTACLES

CONNECTOR	WIRE BUNDLE ASSY	LOCATION	
		BRKT ID	
D04550J	W214	AC0701	
D04630J	W222	AC0702	
D04632J	W262	AC0702	
D04234J	W264	AC0701	
D04232J	W352	AW0305	
D04192J	W356	AW0311	
D04208J	W356	AW0305	
D04224J	W372	AW0310	
D04240J	W374	AW0307	
D04166J	W376	AW0311	
D04258J	W376	AW0305	
D06420J	W380	AW0309	
D04246J	W382	AW0310	
D06422J	W384	AW0309	
D04230J	W386	AW0307	
D04220J	W388	AW0307	
D08334J	W392	AW0310	
D08320J	W396	AW0310	
D04204J	W402	AW0319	
D04238J	W404	AW0320	
D04212J	W406	AW0319	
D04214J	W406	AW0319	
D04252J	W408	AW0320	
D04254J	W408	AW0320	
D04342J	W412	AW0319	
D04344J	W414	AW0320	
D04202J	W416	AW0319	
D04242J	W418	AW0320	
D04234J	W420	AW0319	
D04244J	W422	AW0320	
D06384J	W516	AW0319	
D06382J	W518	AW0320	
D04524J	W744	AC0701	
D04482J	W746	AC0701	
D04528J	W756	AC0701	
D06578J	W758	AC0701	
D04622J	W764	AC0702	
D04616J	W766	AC0702	
D04624J	W768	AC0702	
D06580J	W782	AC0702	
D08342J	W3530	STA NL126	

TABLE 2
CONDUCTIVE PLUGS

CONNECTOR	WIRE BUNDLE ASSY		LOCATION		
			BRKT ID	STA	WL
D04232P	W404		AC0702		
D04634P	W402		AC0701		
D04202P	W352		AW0319		
D04212P	W356		AW0319		
D04214P	W356		AW0319		
D04234P	W372		AW0319		
D04242P	W374		AW0320		
D04252P	W376		AW0320		
D04254P	W376		AW0320		
D04244P	W382		AW0320		
D04204P	W386		AW0319		
D04238P	W388		AW0320		
D06382P	W392		AW0320		
D06384P	W396		AW0319		
D04482P	W406		AC0701		
D04616P	W408		AC0702		
D04524P	W416		AC0701		
D04622P	W418		AC0702		
D04528P	W420		AC0701		
D04624P	W422		AC0702		
D06578P	W516		AC0701		
D06580P	W518		AC0702		
D04224P	W3502		AW0310		
D08346P	W3502		W1J14	NR100	150
D08320P	W3504		AW0310		
D08330P	W3504		W2J14	NR100	150
D08336P	W3504		AW0309	NL113	147
D08316P	W3504			NR100	150
D04192P	W3530		AW0311		
D08350P	W3502	1	AW0312		
D08360P	W3504	1	AW0312		
D08370P	W3502	1	W2J32	NR190	150
D15802P	W3502	1		NR194	150
D15802J	W3504	1		NR194	150



NOTE:

WIRING, CONNECTORS, BONDS AND ELECTRICAL COMPONENTS IN THIS AREA ARE PROTECTED AGAINST EFFECTS OF LIGHTNING. SEE WIRING DIAGRAM MANUAL CHAPTERS 20 AND 73 FOR SPECIAL PRECAUTIONS REQUIRED FOR SERVICING WIRING AND ELECTRICAL COMPONENTS.

BAC27NEL1122

FIGURE 1

PW4000 ENGINE CONTROL-LIGHTNING PROTECTION-CONNECTORS.

LOCATIONS OF LIGHTNING PROTECTED CIRCUITS AND ASSOCIATED CONNECTORS ARE PROVIDED ON THE AIRPLANE BY AREA DECALS (SEE FIGURE 1).

SEE CHAPTER 20 FOR MAINTENANCE AND REWORK OF SHIELDS, ASSOCIATED CONNECTORS AND BACKSHELL HARDWARE IN ORDER TO MAINTAIN NORMAL ENGINE OPERATION DURING AIRPLANE EXPOSURE TO LIGHTNING TRANSIENTS.

ALL CONNECTORS THAT TERMINATE LIGHTNING SHIELDS ARE CONDUCTIVE.

ALL CONDUCTIVE RECEPTACLES MUST BE BONDED TO STRUCTURE PER CHAPTER 20 TO MAINTAIN LIGHTNING PROTECTION.

SEE TABLE 1 FOR COMPLETE LISTING OF CONDUCTIVE RECEPTACLES REQUIRING BONDING AND MAINTENANCE OF SHIELD TERMINATIONS.

SEE TABLE 2 FOR COMPLETE LISTING OF CONDUCTIVE PLUGS REQUIRING MAINTENANCE OF SHIELD TERMINATIONS.

1 APPLICABLE WHEN SUPPLEMENTAL CONTROL UNIT IS INSTALLED

ALL

ELECTRONIC ENGINE CONTROL
LIGHTNING PROTECTION

73-41-01

Page 1

Jan 21/2005

D280T132

73-41-01

Page 1

Jan 21/2005