

CHAPTER

74

IGNITION



**767-200/300
WIRING DIAGRAM MANUAL**

**CHAPTER 74
IGNITION**

CH-SC-SU	Schem	Page	Sheet	Date	CH-SC-SU	Schem	Page	Sheet	Date
74-EFFECTIVE PAGES									
		1		Aug 05/2009					
		2		BLANK					
74-CONTENTS									
		1		Jun 28/2006					
		2		BLANK					
74-ALPHABETICAL INDEX									
		1		Jan 21/2005					
		2		BLANK					
74-31-11									
	1.1	1		Jan 21/2005					
		2		Jan 21/2005					
	2.1	1		Jan 21/2005					
		2		Jan 21/2005					
74-31-21									
	1.1			Jan 21/2005					
	2.1			Jan 21/2005					

A = Added, R = Revised, D = Deleted, O = Overflow

74-EFFECTIVE PAGES

Page 1
Aug 05/2009

D280T132



**767-200/300
WIRING DIAGRAM MANUAL**

**CHAPTER 74
IGNITION**

Title	CH-SC-SU	Schem	Page	Sheet	Date	Effectivity
<u>ENGINE IGNITION CONTROL</u>						
ENGINE IGNITION- LEFT ENGINE	74-31-11		1.1	1	Jan 21/2005	050-167
				2	Jan 21/2005	050-167
			2.1	1	Jan 21/2005	275-280
				2	Jan 21/2005	275-280
ENGINE IGNITION- RIGHT ENGINE	74-31-21		1.1		Jan 21/2005	050-051
			2.1		Jan 21/2005	150-280

74-CONTENTS



**767-200/300
WIRING DIAGRAM MANUAL**

**CHAPTER 74
IGNITION**

CH-SC-SU	Title
74-31-11	ENGINE IGNITION- LEFT ENGINE
74-31-21	ENGINE IGNITION- RIGHT ENGINE

74-ALPHABETICAL INDEX

D280T132

Page 1
Jan 21/2005

76

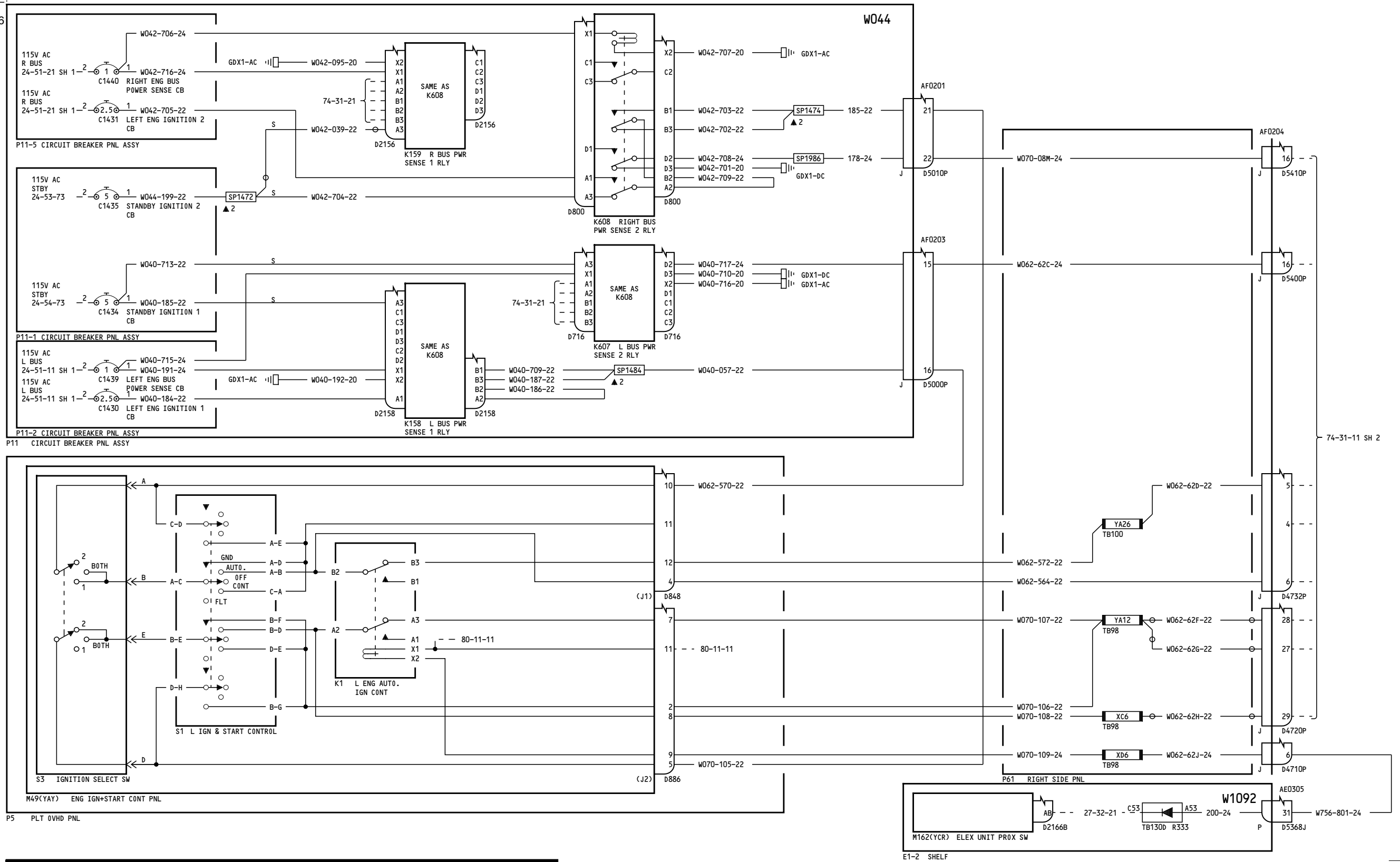

050-167

**ENGINE IGNITION-
LEFT ENGINE**

D280T132

74-31-11

Page 1.1
Sheet 1
Jan 21/2005

Incorporates
73-0044 R01

74-31-11

Page 1.1
Sheet 1
Jan 21/2005

74-31-11 SH 1

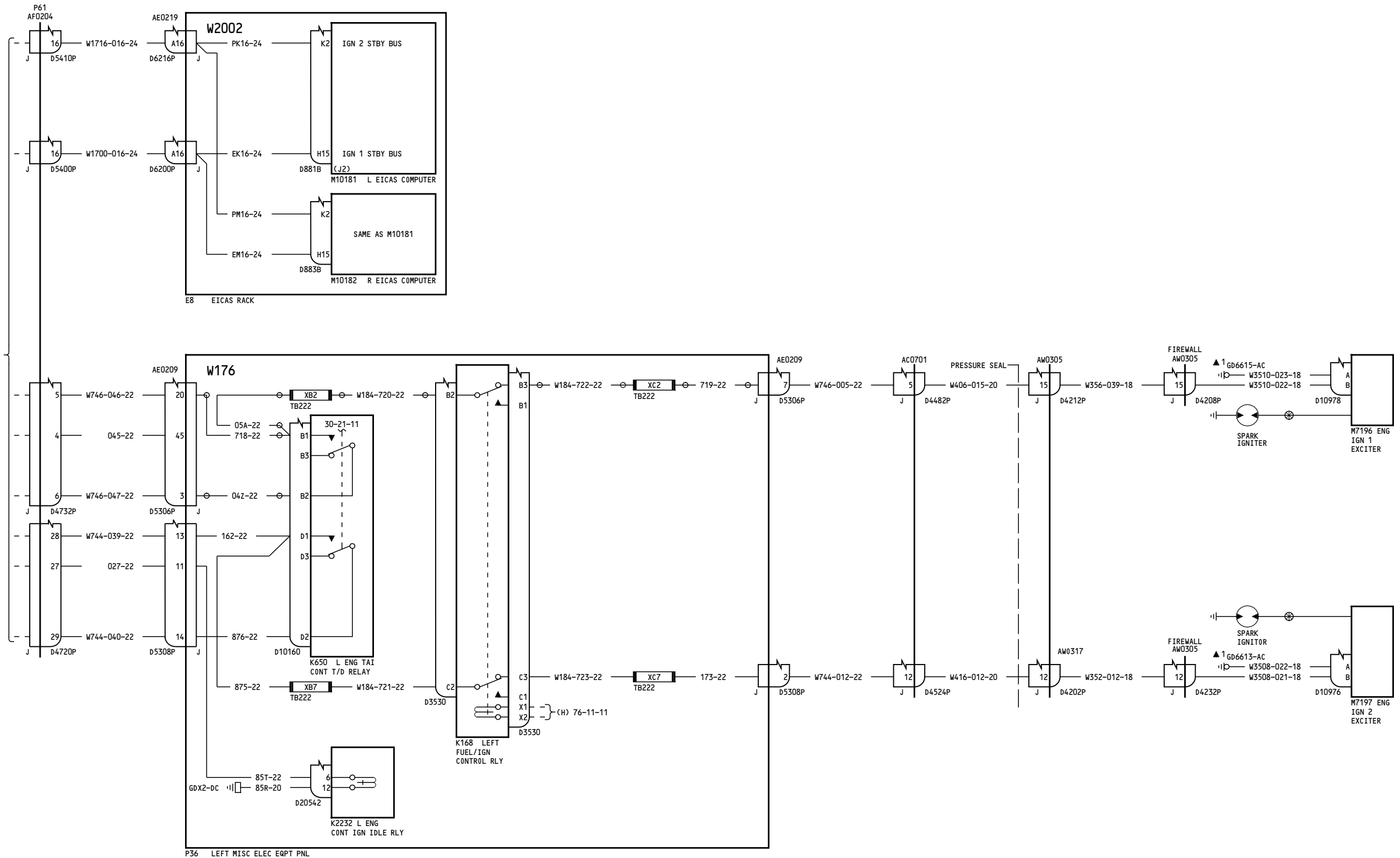

050-167

**ENGINE IGNITION-
LEFT ENGINE**

D280T132

74-31-11

Page 1.1
Sheet 2
Jan 21/2005

Incorporates
73-0044 R01

74-31-11

Page 1.1
Sheet 2
Jan 21/2005

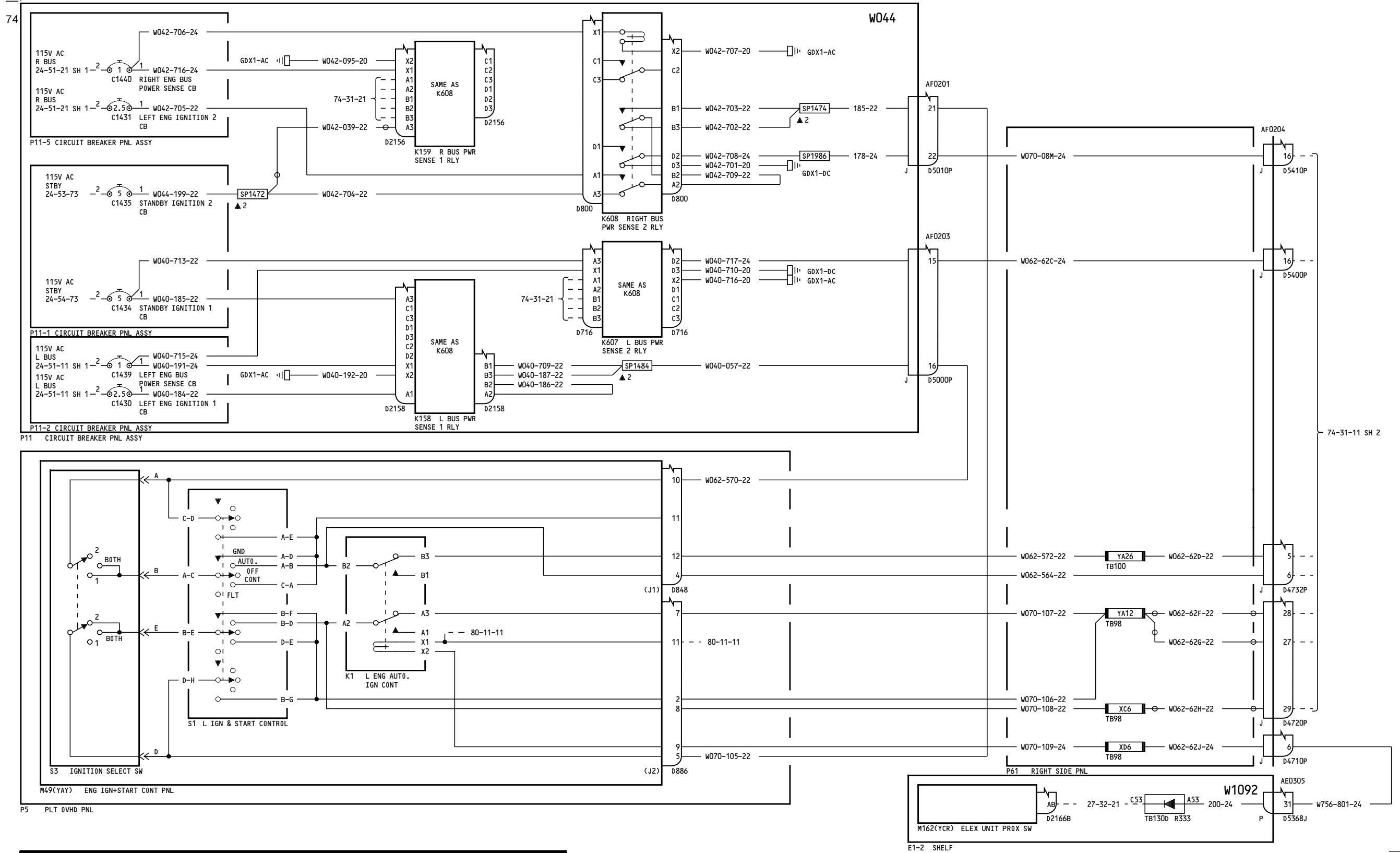

275-280

**ENGINE IGNITION-
LEFT ENGINE**

D280T132

74-31-11

Page 2.1
Sheet 1
Jan 21/2005

Incorporates
73-0044 R01

74-31-11

Page 2.1
Sheet 1
Jan 21/2005

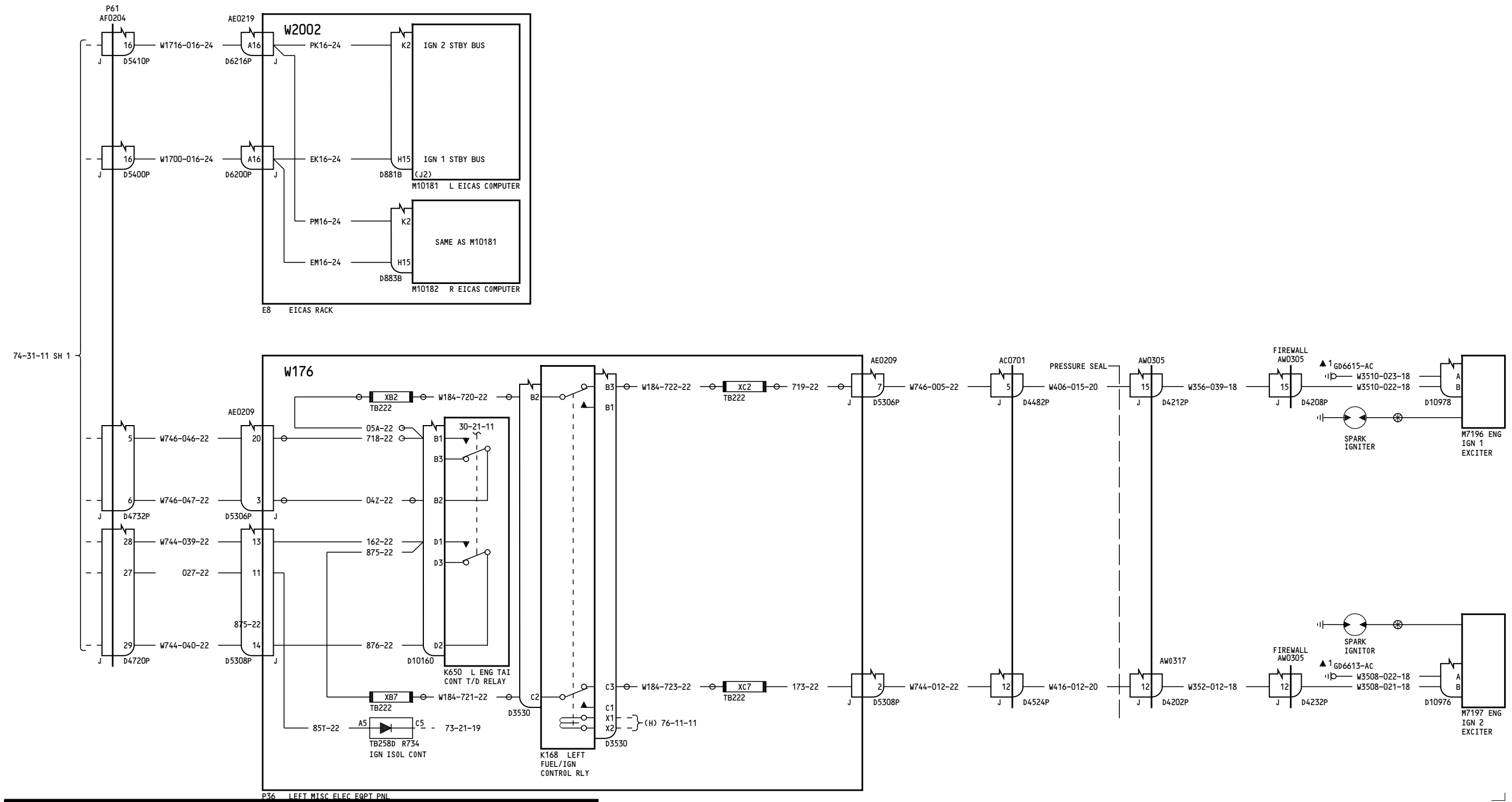

275-280

**ENGINE IGNITION-
LEFT ENGINE**

D280T132

74-31-11

Page 2.1
Sheet 2
Jan 21/2005

Incorporates
73-0044 R01

74-31-11

Page 2.1
Sheet 2
Jan 21/2005

79

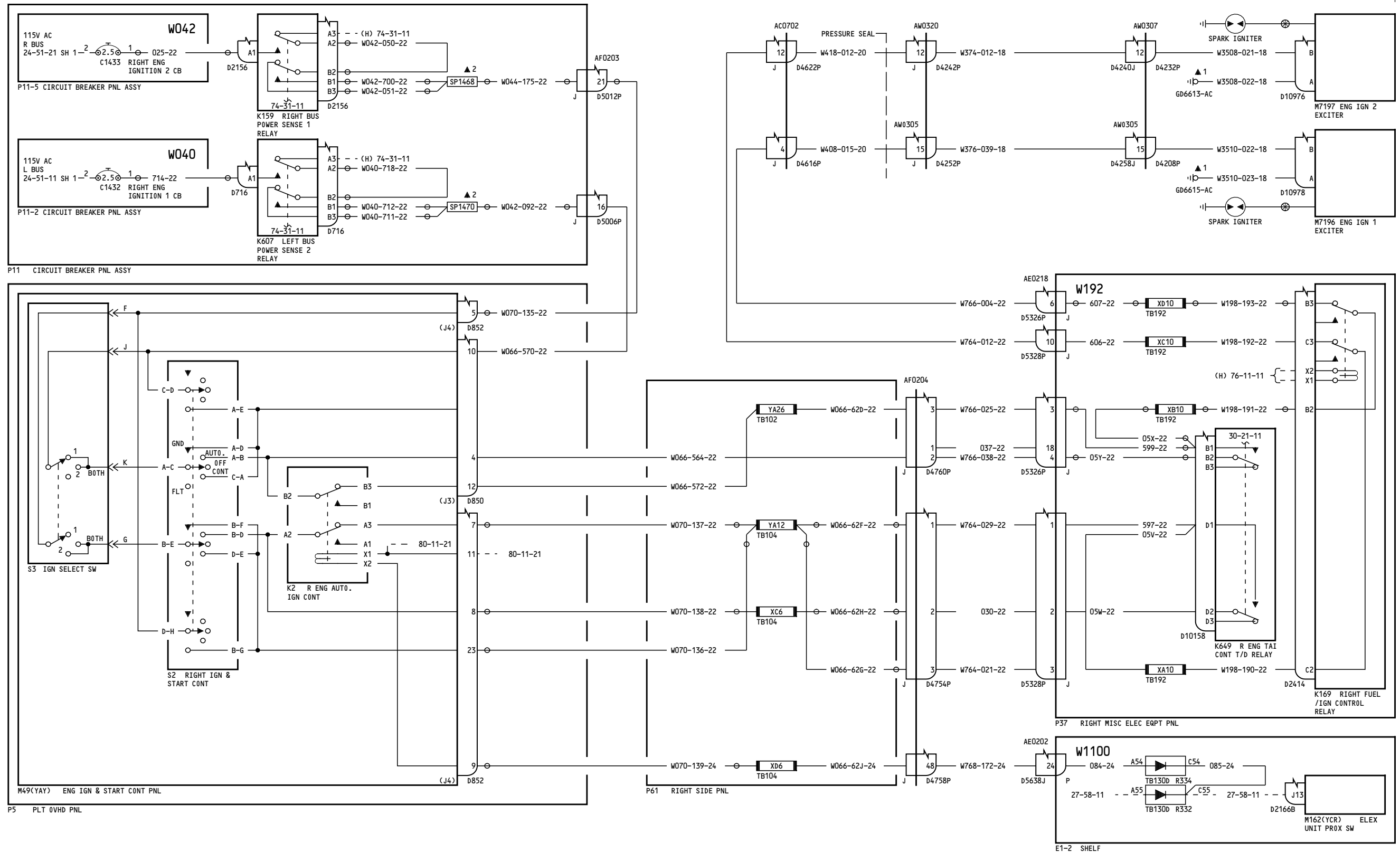

050-051

**ENGINE IGNITION-
RIGHT ENGINE**

D280T132

74-31-21

Page 1.1

Jan 21/2005

Incorporates
73-0044 R01

74-31-21

Page 1.1

Jan 21/2005

78

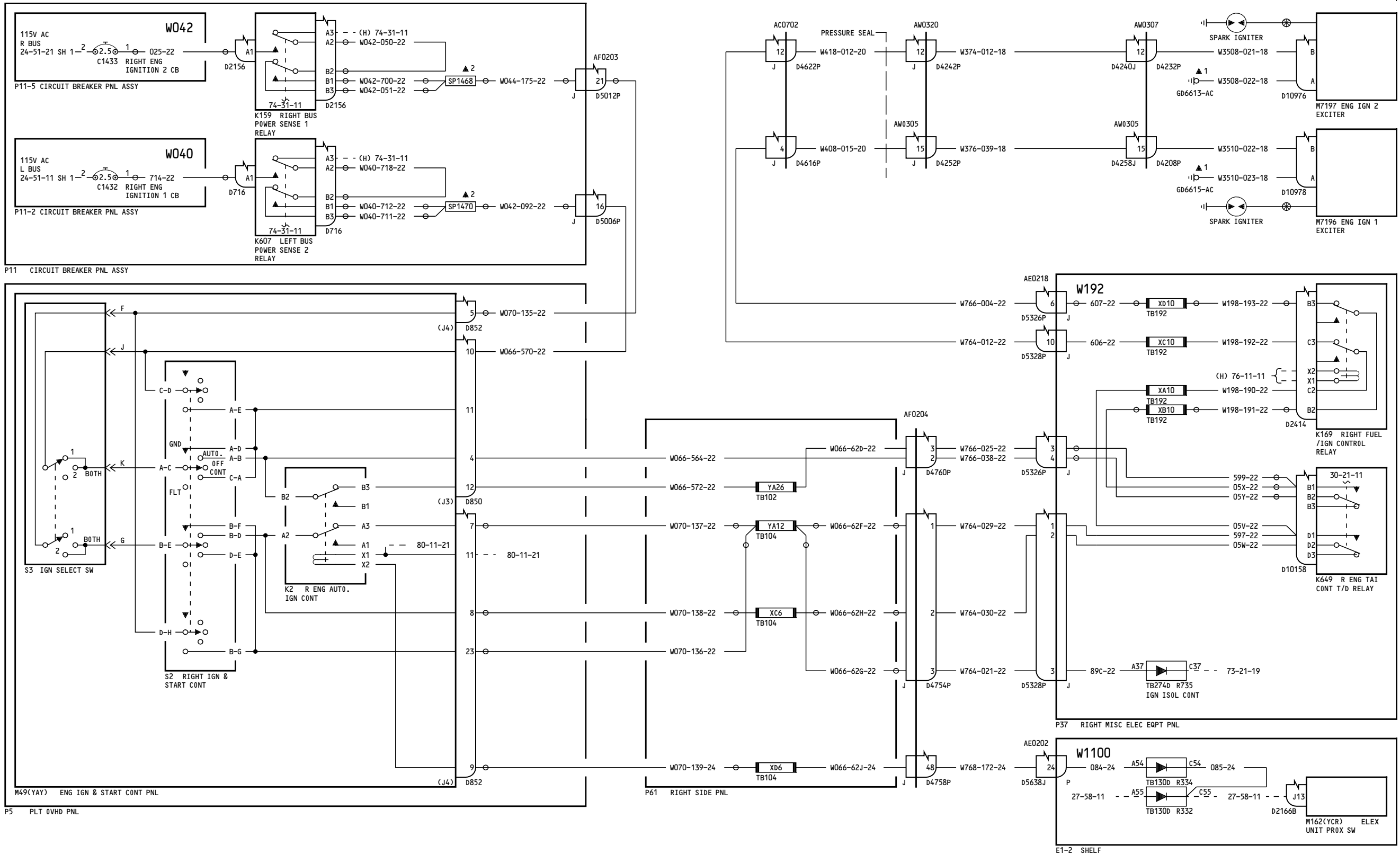

150-280

**ENGINE IGNITION-
RIGHT ENGINE**

D280T132

74-31-21

Page 2.1

Jan 21/2005

Incorporates
73-0044 R01

74-31-21

Page 2.1

Jan 21/2005