

CHAPTER

76

ENGINE CONTROLS



767-200/300

WIRING DIAGRAM MANUAL

CHAPTER 76 ENGINE CONTROLS

CH-SC-SU	Schem	Page	Sheet	Date	CH-SC-SU	Schem	Page	Sheet	Date
76-EFFECTIVE PAGES									
		1		Aug 05/2009					
		2		BLANK					
76-CONTENTS									
		1		Jun 28/2006					
		2		BLANK					
76-ALPHABETICAL INDEX									
		1		Jan 21/2005					
		2		BLANK					
76-11-11									
	1.1	1	1	Jan 21/2005					
			2	Jan 21/2005					
	2.1	1	1	Jan 21/2005					
			2	Jan 21/2005					
	3.1	1	1	Jan 21/2005					
			2	Jan 21/2005					
	4	1	1	Jan 21/2005					
			2	Jan 21/2005					
	5	1	1	Jan 21/2005					
			2	Jan 21/2005					
	6.1	1	1	Jan 21/2005					
			2	Jan 21/2005					
	7	1	1	Jan 21/2005					
			2	Jan 21/2005					

A = Added, R = Revised, D = Deleted, O = Overflow

76-EFFECTIVE PAGES

Page 1
Aug 05/2009

D280T132



767-200/300

WIRING DIAGRAM MANUAL

CHAPTER 76 ENGINE CONTROLS

Title	CH-SC-SU	Schem	Page	Sheet	Date	Effectivity
<u>ENGINE CONTROL SYSTEM</u>						
ENGINE FUEL	76-11-11		1.1	1	Jan 21/2005	050
CONDITIONING CONTROL				2	Jan 21/2005	050
			2.1	1	Jan 21/2005	051
				2	Jan 21/2005	051
			3.1	1	Jan 21/2005	150-154
				2	Jan 21/2005	150-154
			4	1	Jan 21/2005	155
				2	Jan 21/2005	155
			5	1	Jan 21/2005	156-199
				2	Jan 21/2005	156-199
			6.1	1	Jan 21/2005	275-276
				2	Jan 21/2005	275-276
			7	1	Jan 21/2005	277-299
				2	Jan 21/2005	277-299

76-CONTENTS

Page 1
Jun 28/2006

D280T132



767-200/300

WIRING DIAGRAM MANUAL

**CHAPTER 76
ENGINE CONTROLS**

CH-SC-SU	Title
76-11-11	ENGINE FUEL CONDITIONING CONTROL

76-ALPHABETICAL INDEX

D280T132

Page 1
Jan 21/2005

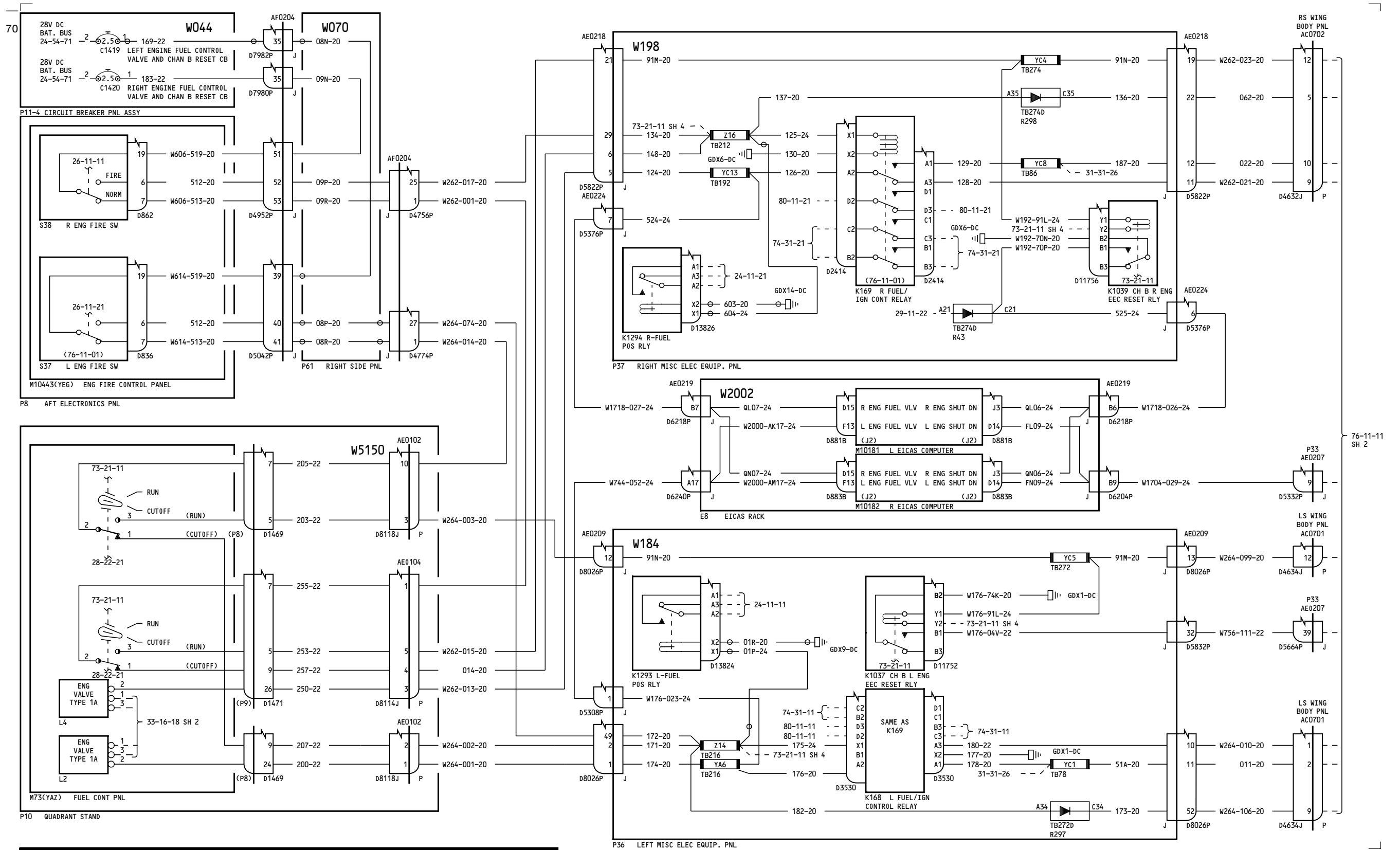

050

ENGINE FUEL CONDITIONING CONTROL

D280T132

76-11-11

Page 1.1
Sheet 1
Jan 21/2005

Incorporates
24-0059
76-0024

76-11-11

Page 1.1
Sheet 1
Jan 21/2005

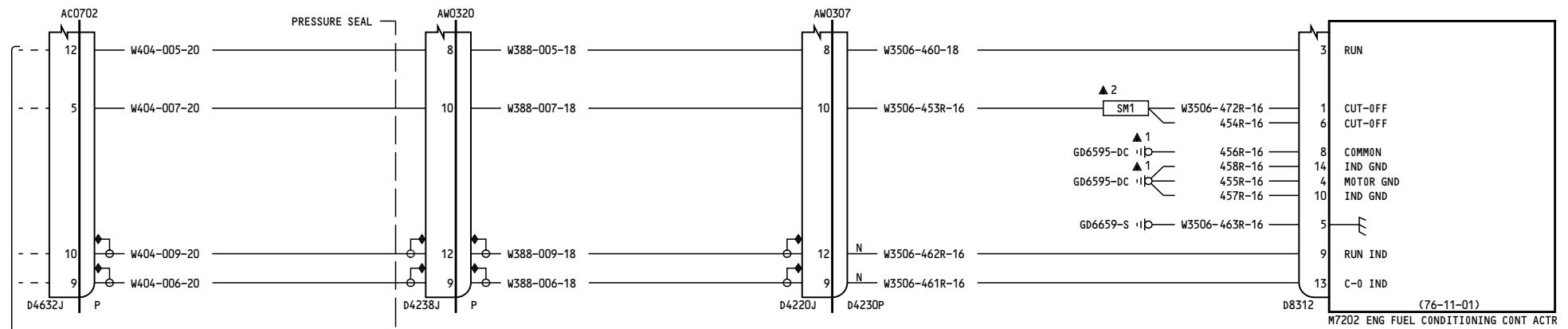

76-11-11 SH 1

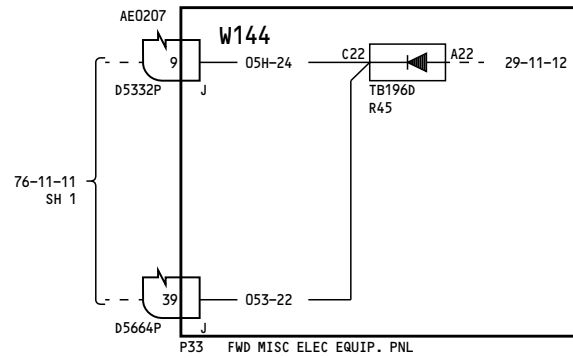

NOTES:
SHIELD PIGTAIL TO DISCONNECT BACKSHELL 2 INCH MAXIMUM

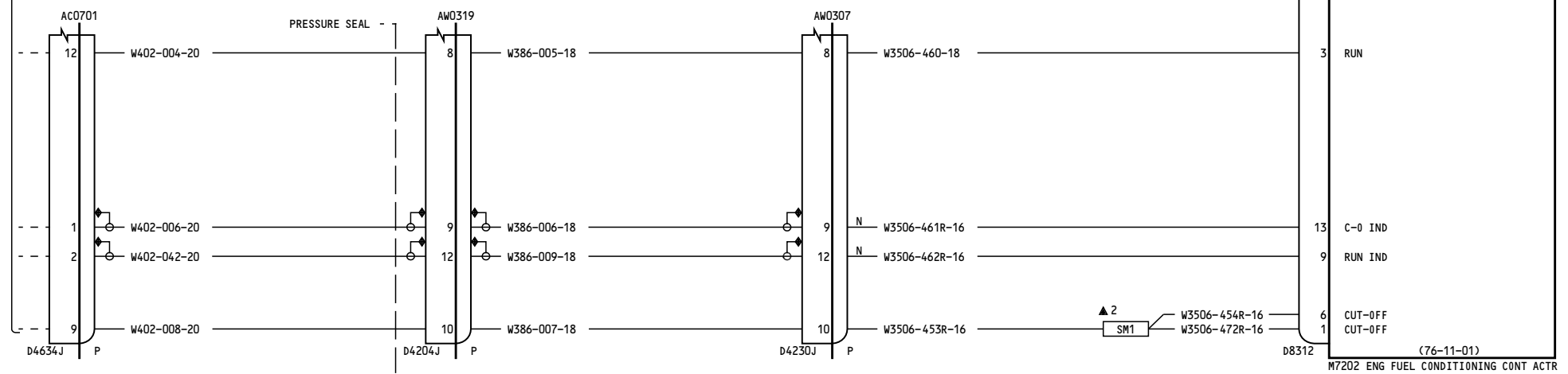

050

ENGINE FUEL CONDITIONING CONTROL

76-11-11

Page 1.1
Sheet 2
Jan 21/2005

D280T132

76-11-11

Page 1.1
Sheet 2
Jan 21/2005

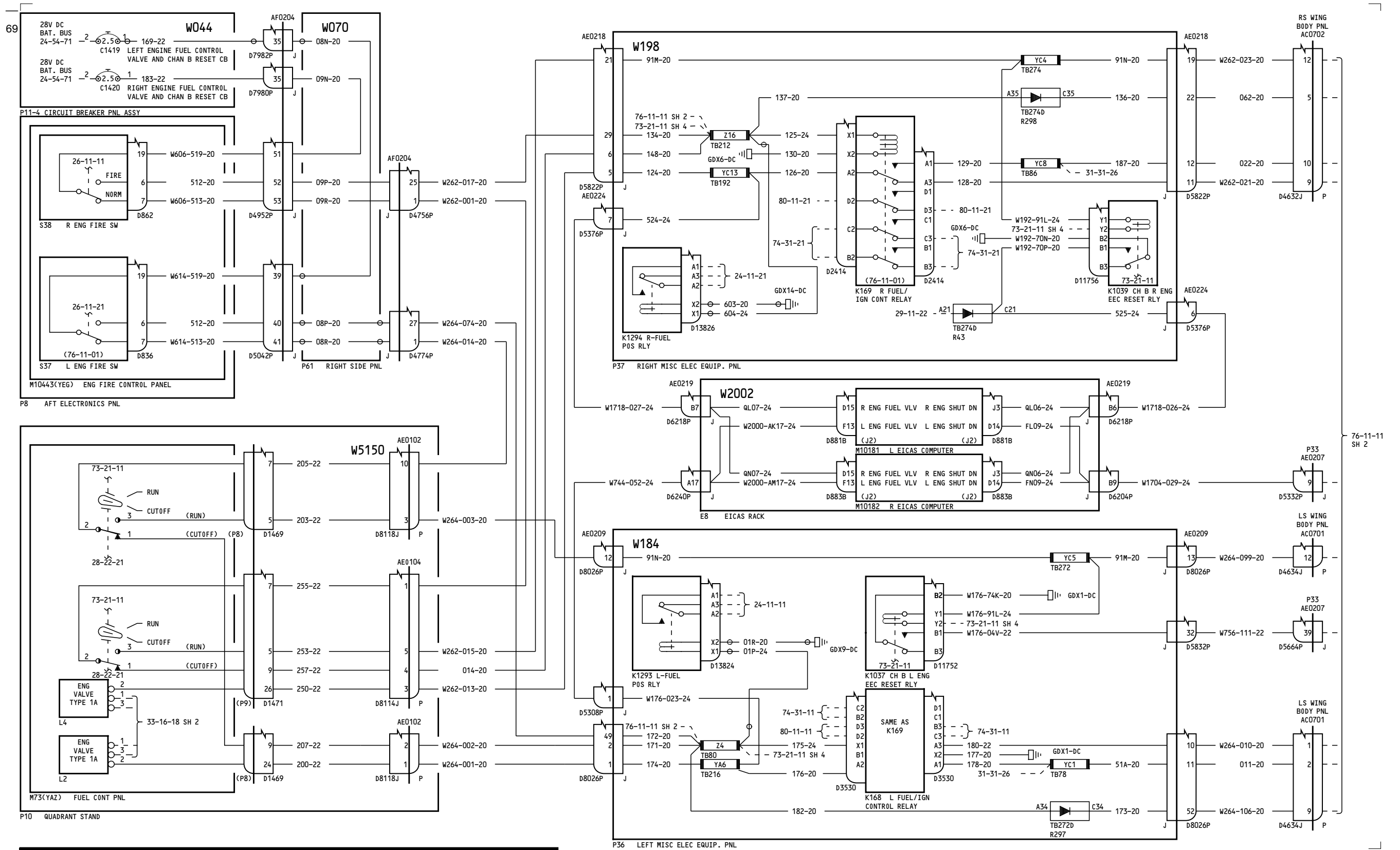

051

ENGINE FUEL CONDITIONING CONTROL

D280T132

76-11-11

Page 2.1
Sheet 1
Jan 21/2005

Incorporates
24-0059

76-11-11

Page 2.1
Sheet 1
Jan 21/2005

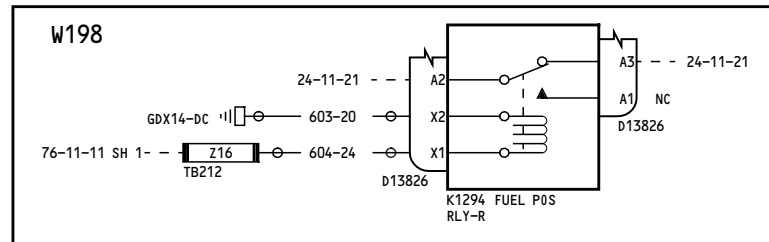
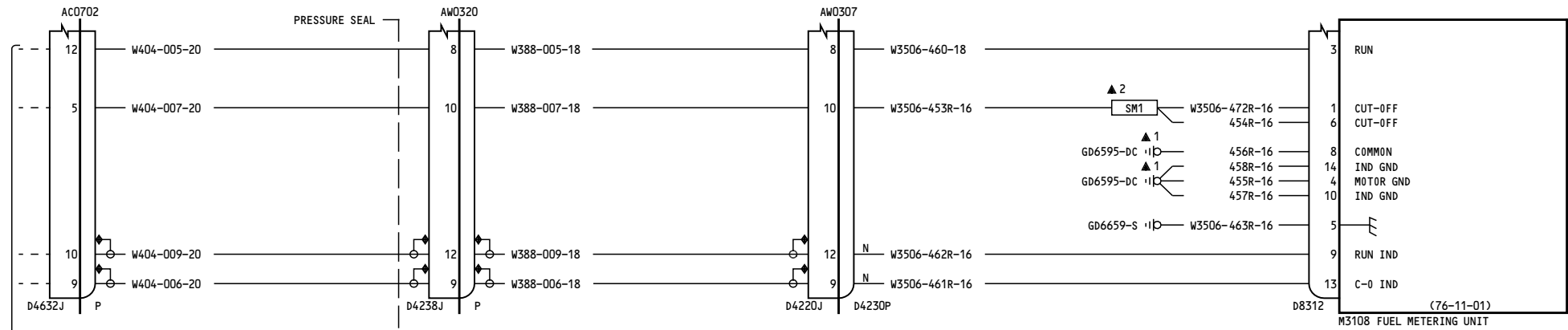

P37 RIGHT MISC ELEC EQUIP. PNL

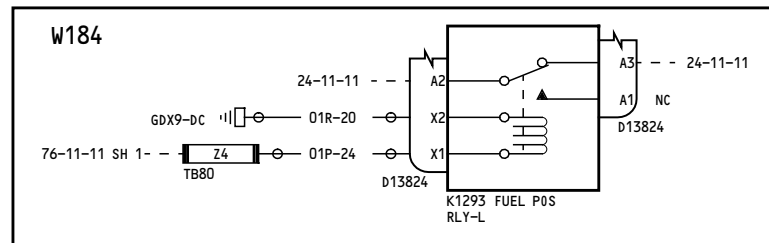

P36 LEFT MISC ELEC EQUIP. PNL

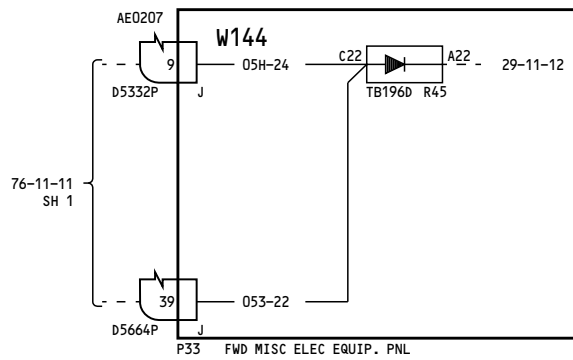
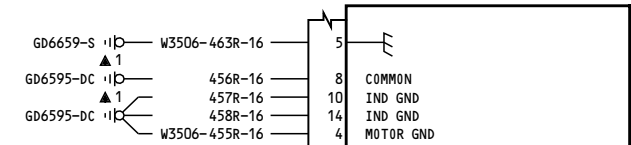

P33 FWD MISC ELEC EQUIP. PNL

NOTES:
SHIELD PIGTAIL TO DISCONNECT BACKSHELL 2 INCH MAXIMUM

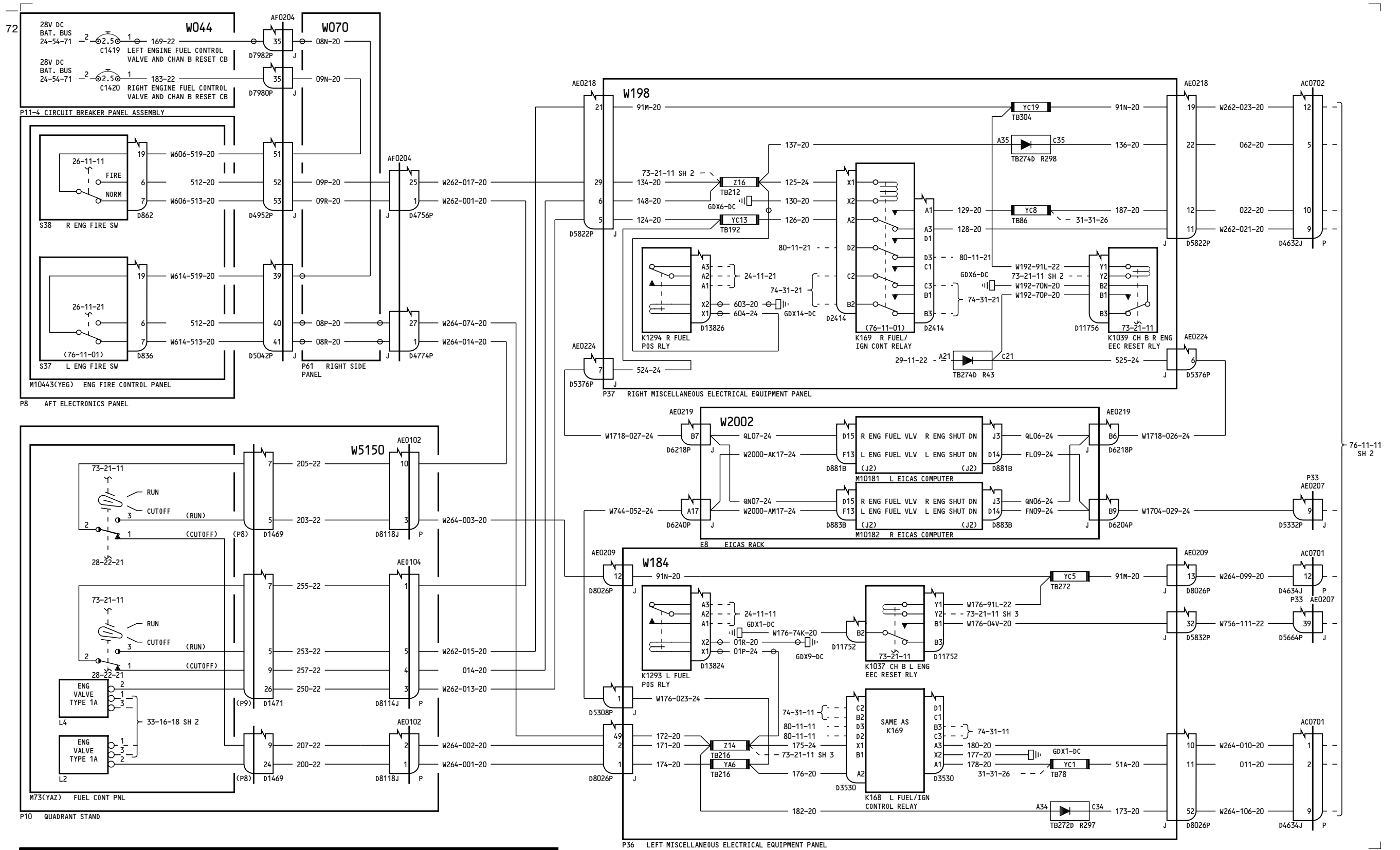

150-154

ENGINE FUEL CONDITIONING CONTROL

D280T132

76-11-11

Page 3.1
Sheet 1
Jan 21/2005

Incorporates
24-0059
76-0024

76-11-11

Page 3.1
Sheet 1
Jan 21/2005

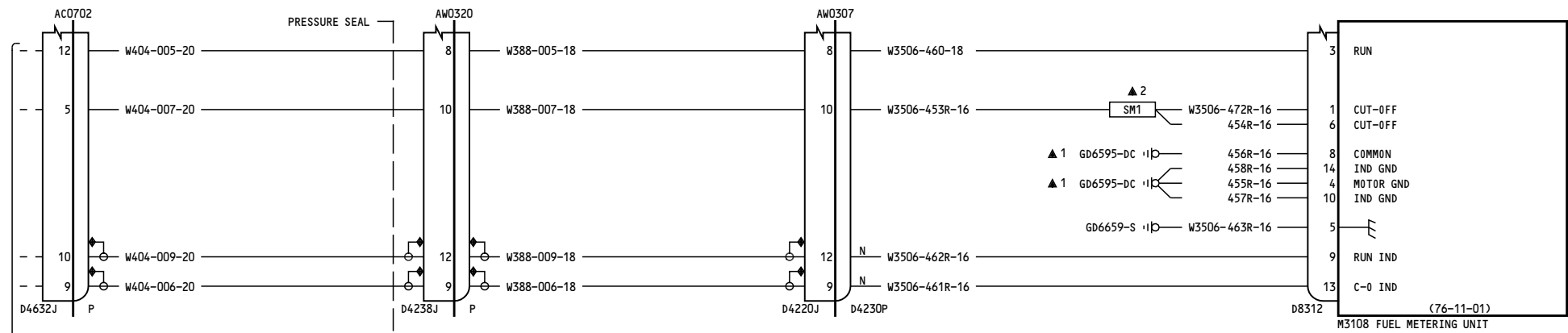

76-11-11 SH 1

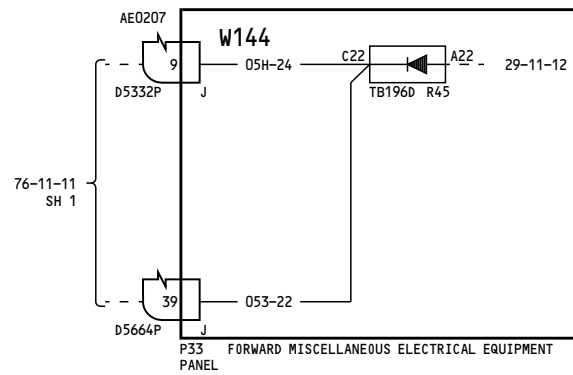

NOTES:
SHIELD PIGTAIL TO DISCONNECT BACKSHELL 2 INCH MAXIMUM

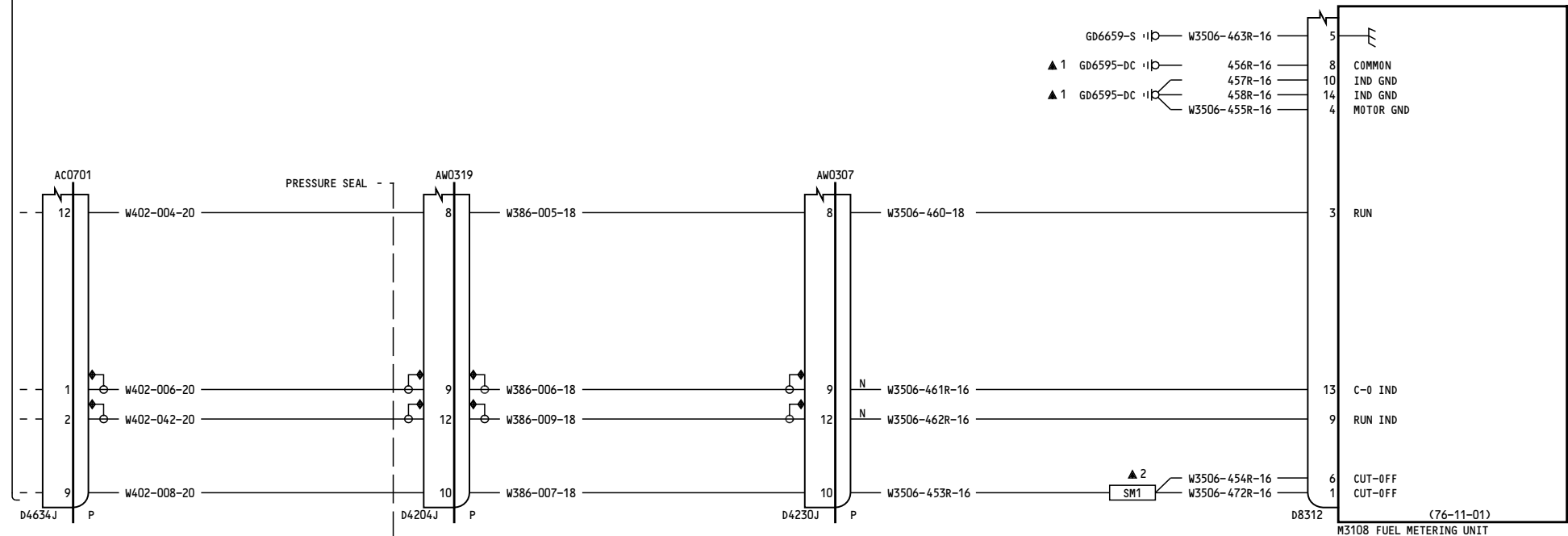

150-154

ENGINE FUEL CONDITIONING CONTROL

D280T132

76-11-11

Page 3.1
Sheet 2
Jan 21/2005

Incorporates
76-0024

76-11-11

Page 3.1
Sheet 2
Jan 21/2005

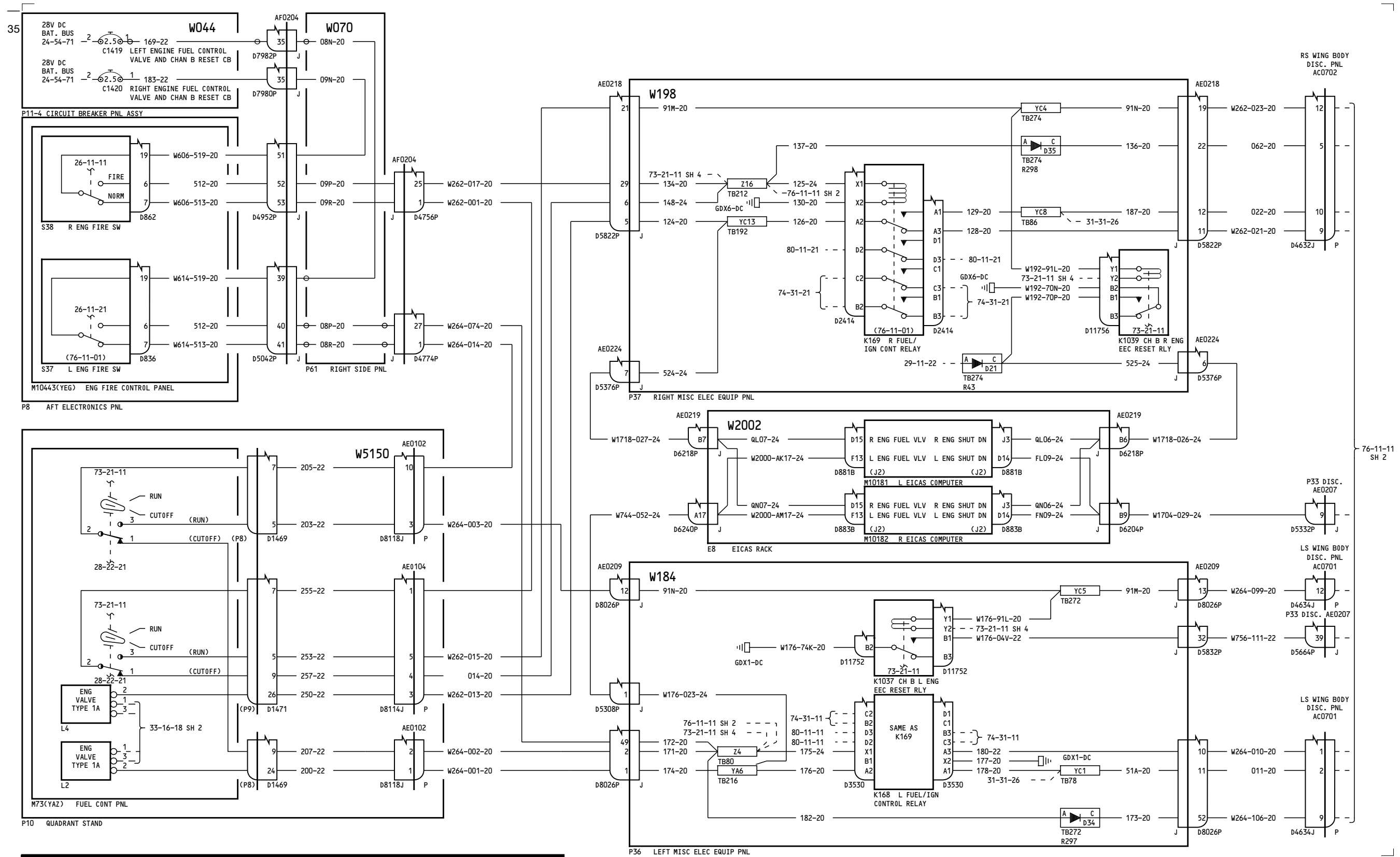

155

ENGINE FUEL CONDITIONING CONTROL
 D280T132

76-11-11
 Page 4
 Sheet 1
 Jan 21/2005

76-11-11
 Page 4
 Sheet 1
 Jan 21/2005

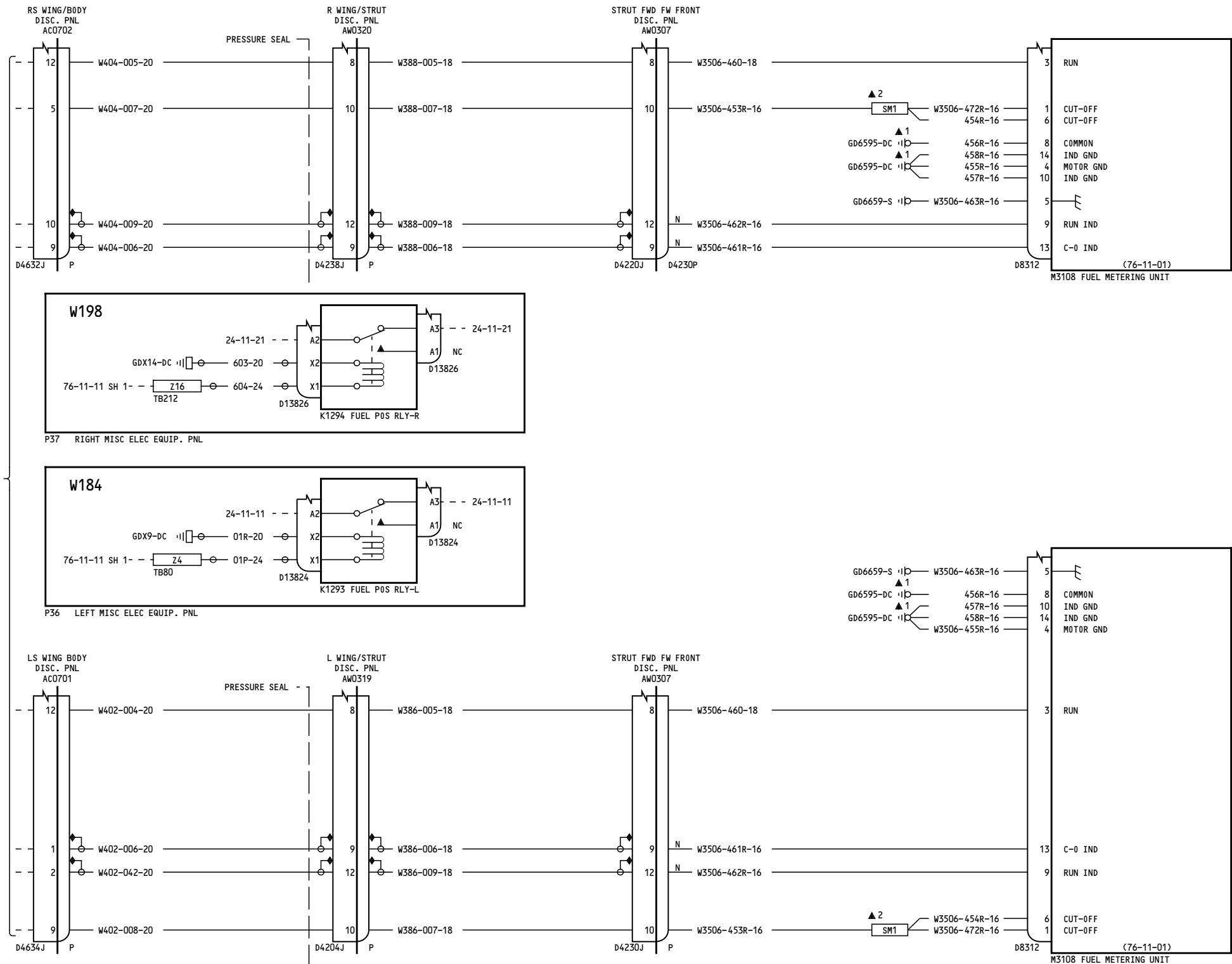

NOTES:
SHIELD PIGTAIL TO DISCONNECT BACKSHELL 2 INCH MAXIMUM

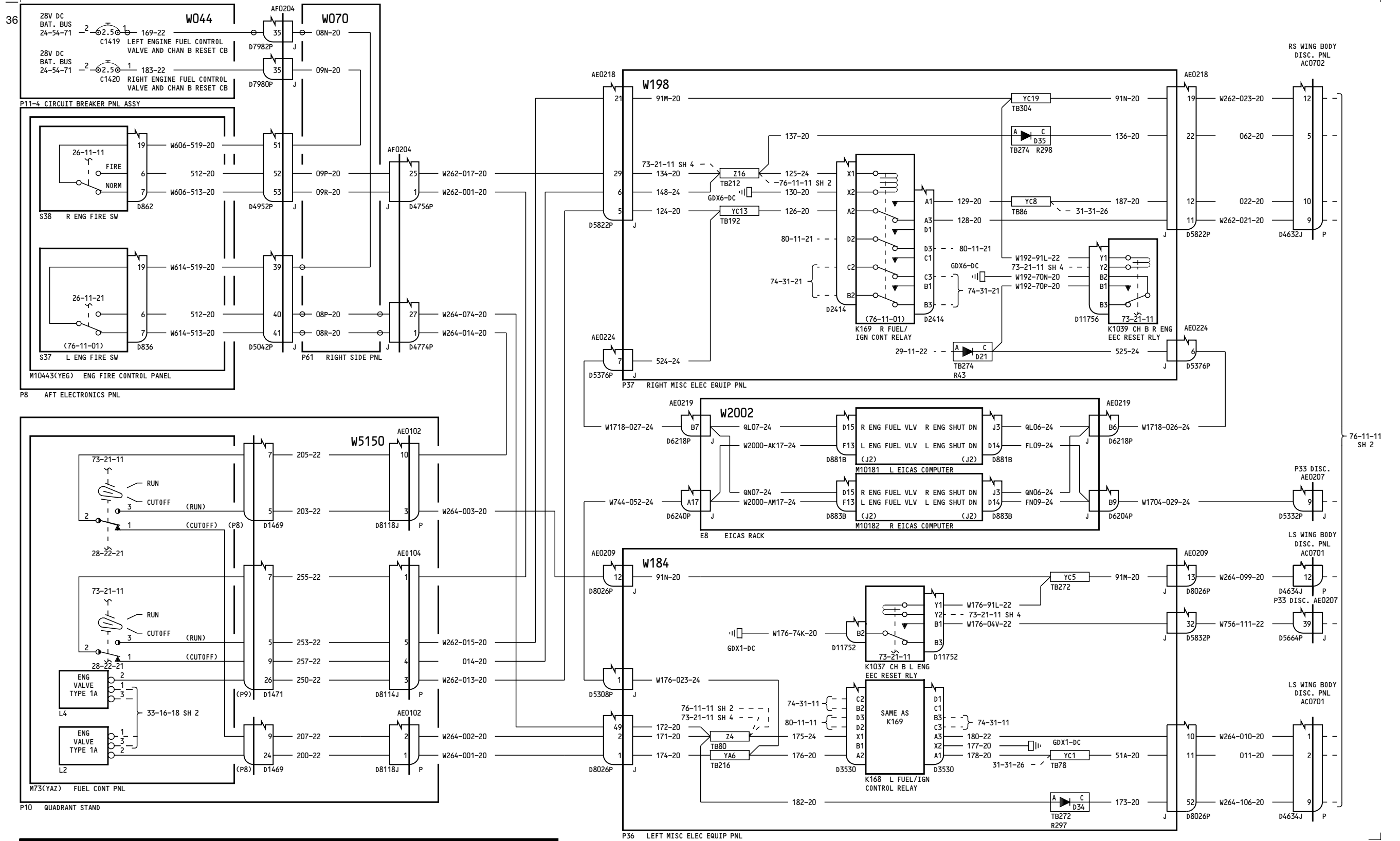

156-199

ENGINE FUEL CONDITIONING CONTROL

D280T132

76-11-11

Page 5
Sheet 1
Jan 21/2005

76-11-11

Page 5
Sheet 1
Jan 21/2005

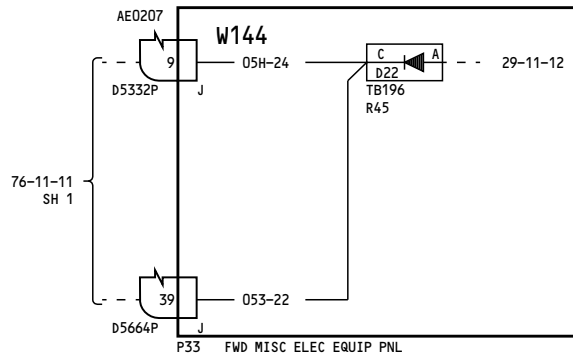
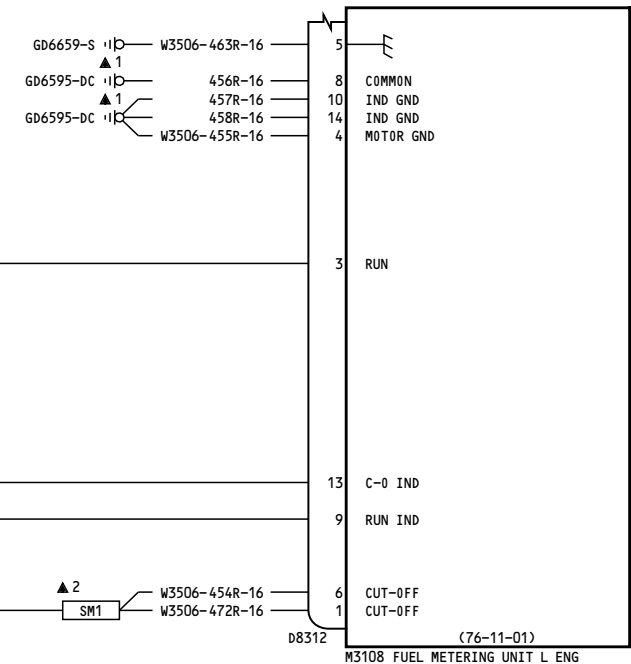
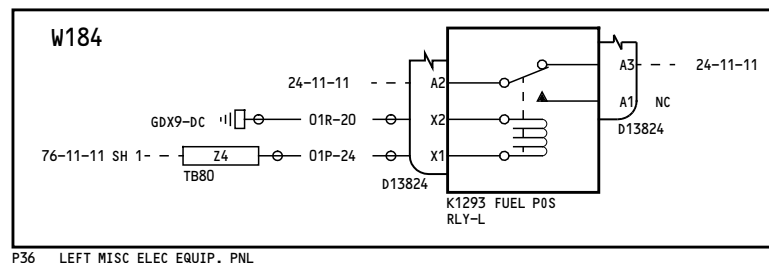
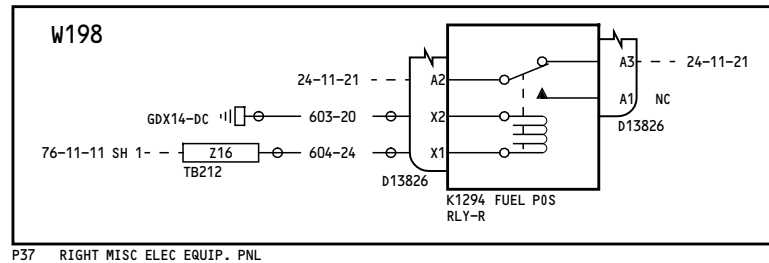
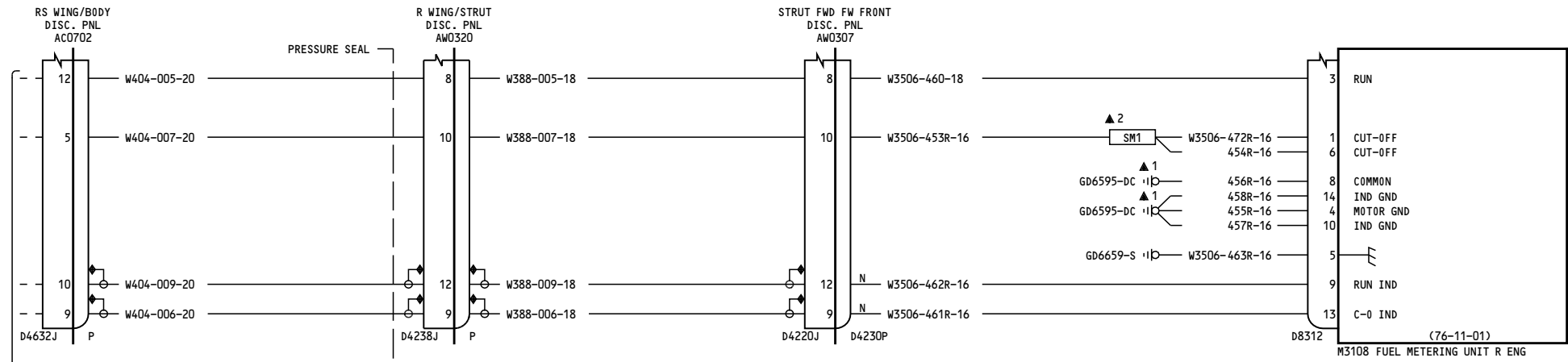

NOTES:
SHIELD PIGTAIL TO DISCONNECT BACKSHELL 2 INCH MAXIMUM

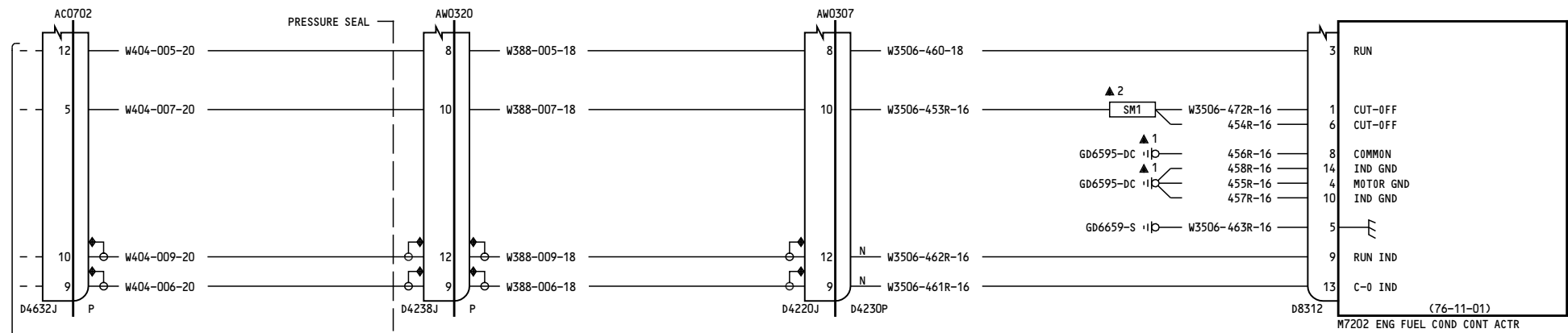

76-11-11 SH 1

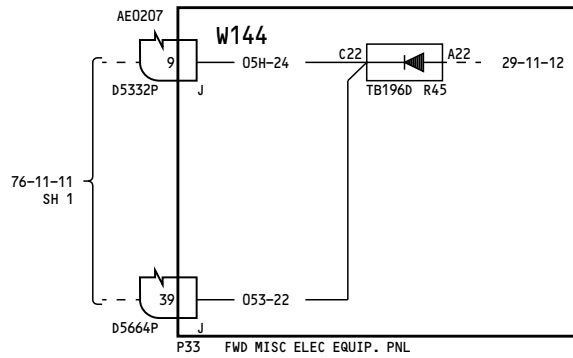

NOTES:
SHIELD PIGTAIL TO DISCONNECT BACKSHELL 2 INCH MAXIMUM

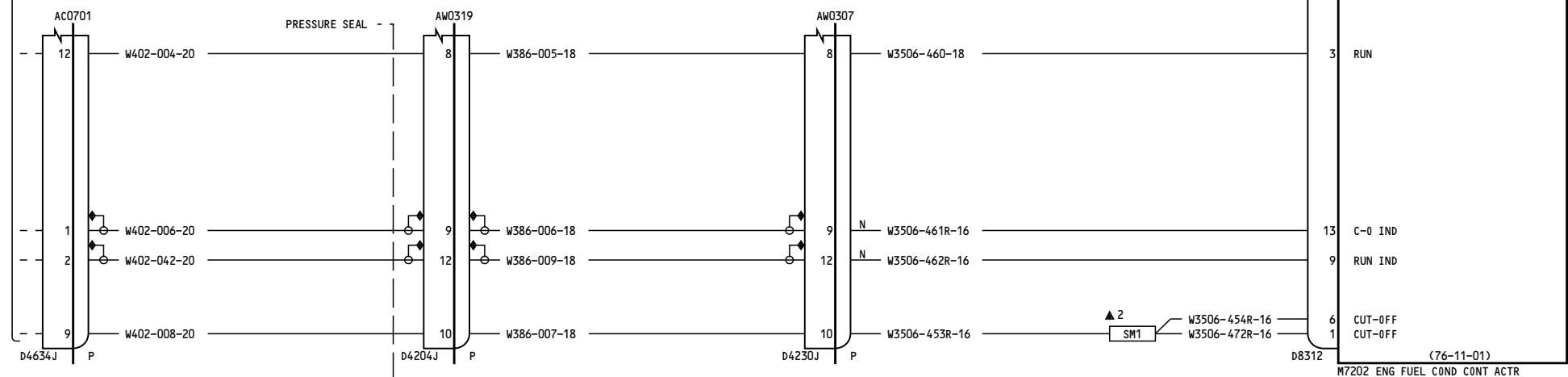

275-276

ENGINE FUEL CONDITIONING CONTROL

76-11-11

Page 6.1
Sheet 2
Jan 21/2005

D280T132

76-11-11

Page 6.1
Sheet 2
Jan 21/2005

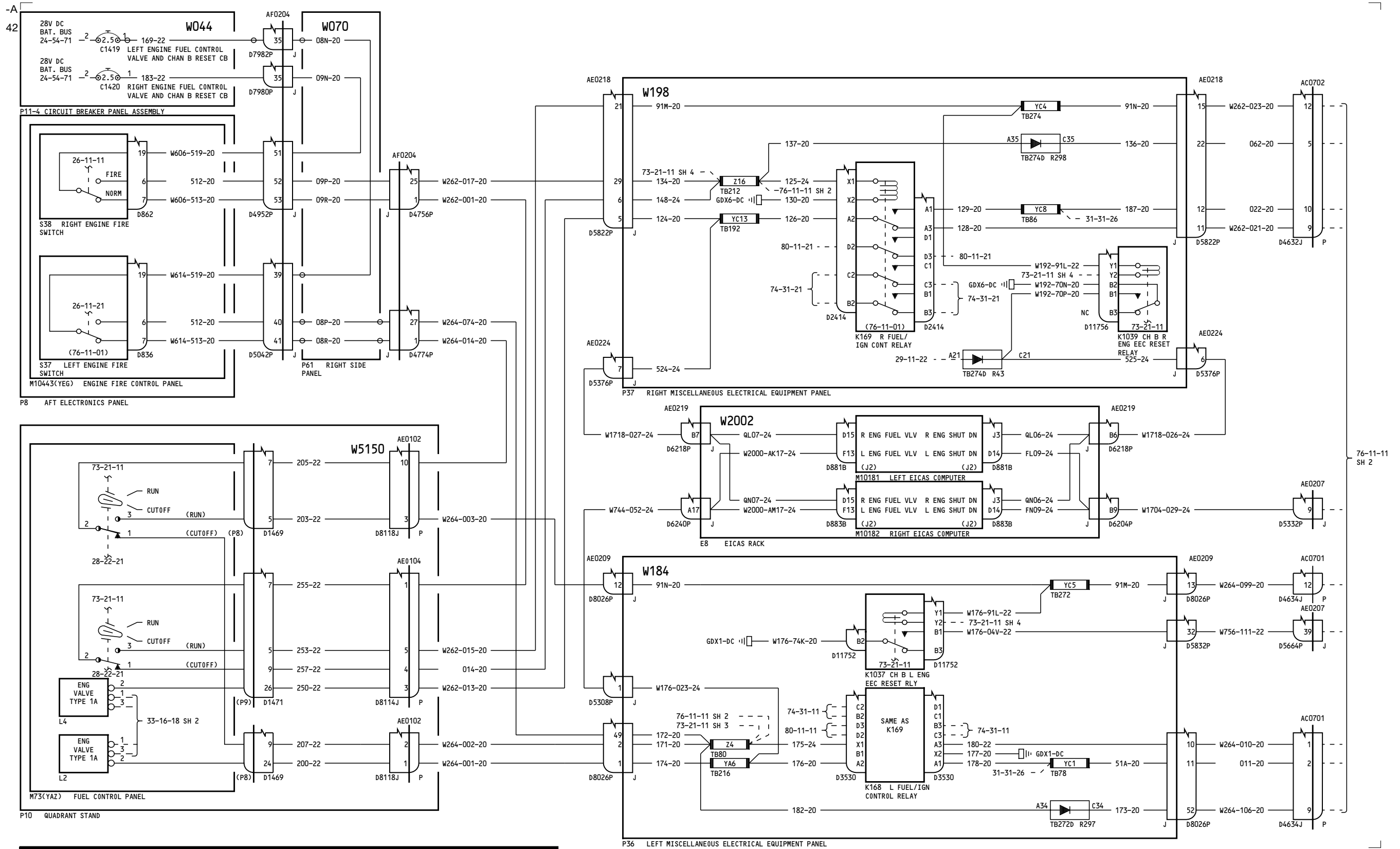

277-299

ENGINE FUEL CONDITIONING CONTROL

D280T132

BOEING PROPRIETARY - Copyright © - Unpublished Work - See title page for details.

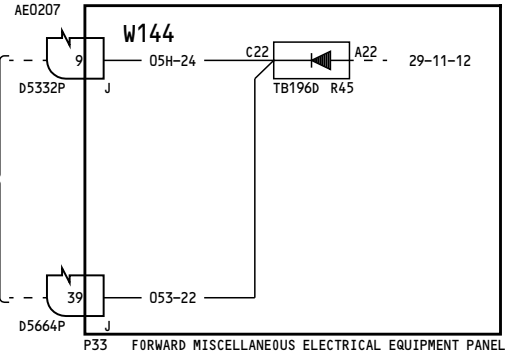
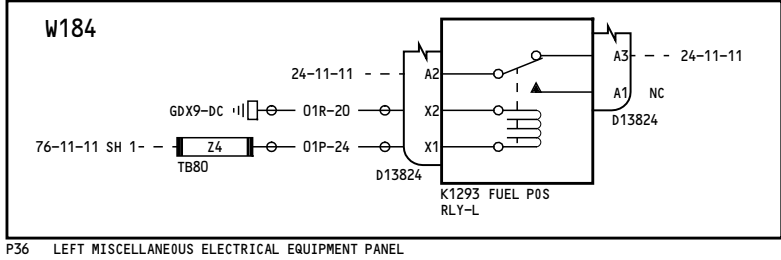
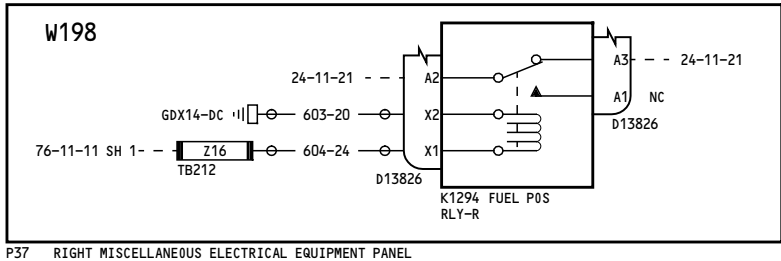
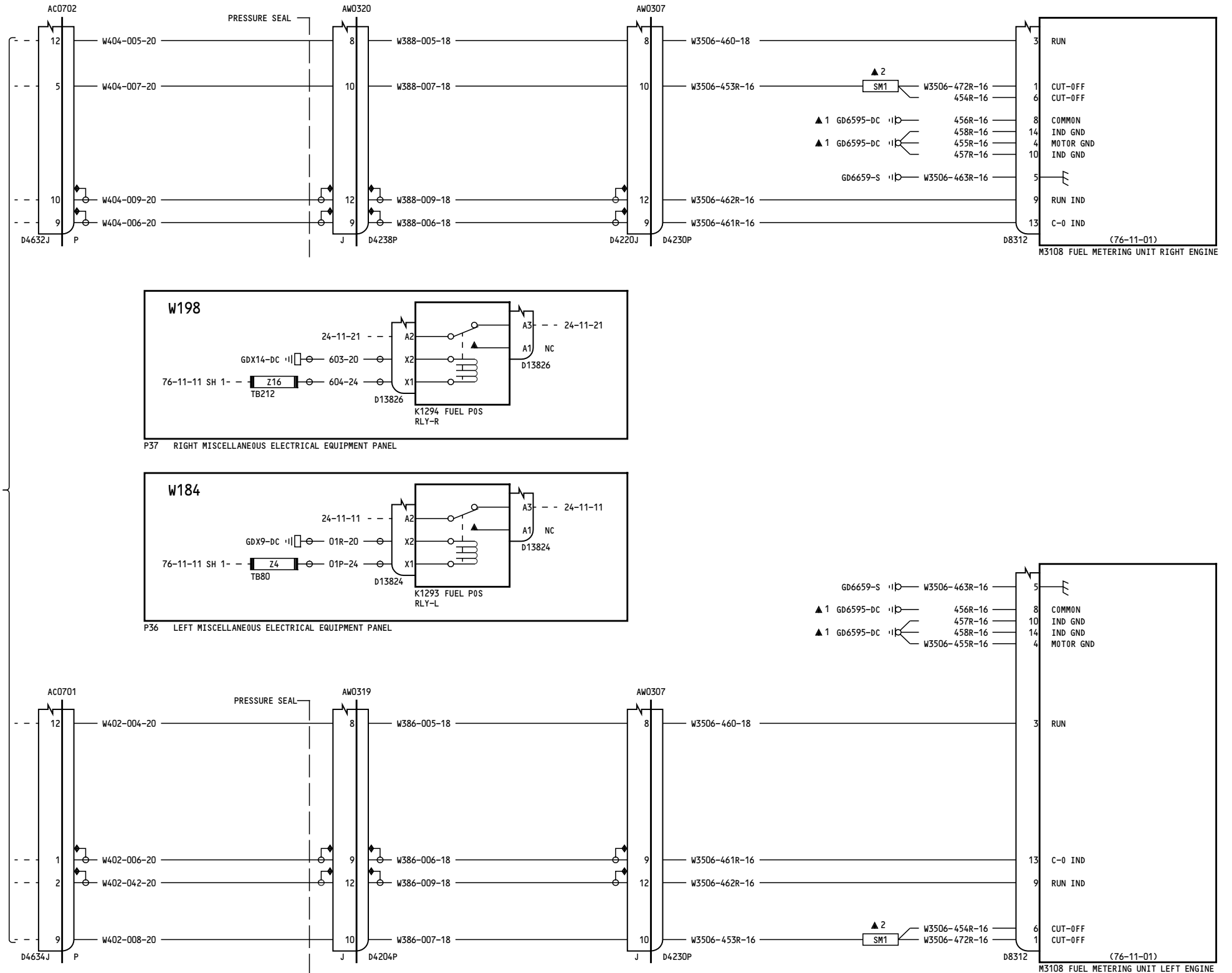

NOTES:
SHIELD PIGTAIL TO DISCONNECT BACKSHELL 2 INCH MAXIMUM