

Color Video Camera

Operating Instructions

Before operating the unit, please read this manual thoroughly and retain it for future reference.

Power HAD
Power HAD WS

DXC-D35K/D35PK
DXC-D35L/D35PL
DXC-D35WSL/D35WSPL
DXC-D35H/D35PH

WARNING

To prevent fire or shock hazard, do not expose the unit to rain or moisture.

To avoid electrical shock, do not open the cabinet. Refer servicing to qualified personnel only.

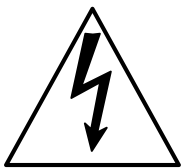
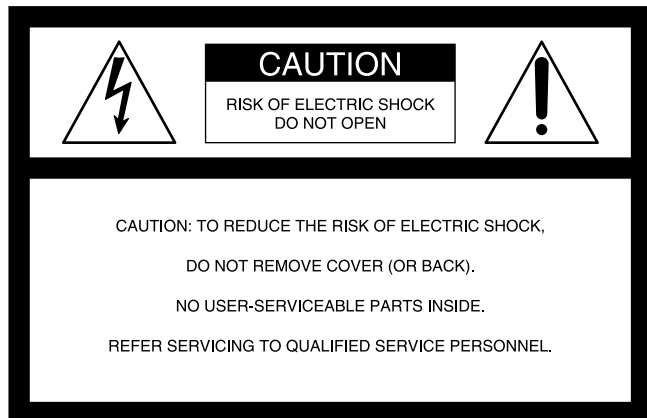

This symbol is intended to alert the user to the presence of uninsulated "dangerous voltage" within the product's enclosure that may be of sufficient magnitude to constitute a risk of electric shock to persons.



This symbol is intended to alert the user to the presence of important operating and maintenance (servicing) instructions in the literature accompanying the appliance.

Owner's Record

The model and serial numbers are located on the top. Record these numbers in the spaces provided below. Refer to them whenever you call upon your Sony dealer regarding this product.

Model No. _____ Serial No. _____

LITHIUM BATTERY

Replace the battery with a Sony CR2032 lithium battery. Use of another battery may present a risk of fire or explosion.

WARNING

Battery may explode if mistreated.
Do not recharge, disassemble or dispose of in fire.

Note

Keep the lithium battery out of the reach of children.
Should the battery be swallowed, consult a doctor immediately.

ADVARSEL!

Lithiumbatteri - Eksplosionsfare ved fejlagtig håndtering. Udskiftning må kun ske med batteri af samme fabrikat og type.

Levér det brugte batteri tilbage til laverandøren.

ADVARSEL

Lithiumbatteri - Eksplosjonsfare. Ved utskifting benyttes kun batteri som anbefalt av apparatfabrikanten.

Brukt batteri returneres apparatleverandøren.

VARNING

Explosionsfara vid felaktigt batteribyte. Använd samma batterityp eller en likvärdig typ som rekommenderas av apparattillverkaren. Kassera använt batteri enligt gällande föreskrifter.

VAROITUS

Paristo voi räjähtää jos se on virheellisesti asennettu. Vaihda paristo ainoastaan laitevalmistajan suosittelemaan tyyppiin. Hävitä käytetty paristo valmistajan ohjeiden mukaisesti.

For the customers in the USA and Canada

RECYCLING NICKEL-CADMIUM BATTERIES

Nickel Cadmium batteries are recyclable. You can help preserve our environment by returning your unwanted batteries to your nearest point for collection, recycling or proper disposal.

Note: In some areas the disposal of nickel cadmium batteries in household or business trash may be prohibited.



RBRC (Rechargeable Battery Recycling Corporation) advises you about spent battery collection by the following phone number.

Call toll free number: 1-800-822-8837 (United States and Canada only)

Caution: Do not handle damaged or leaking nickel-cadmium batteries.

For safety reasons, be sure to discharge the battery before discarding it.

For customers in the USA (for DXC-D35K/D35L/D35WSL/D35H)

This equipment has been tested and found to comply with the limits for a Class A digital device, pursuant to Part 15 of the FCC Rules. These limits are designed to provide reasonable protection against harmful interference when the equipment is operated in a commercial environment. This equipment generates, uses, and can radiate radio frequency energy and, if not installed and used in accordance with the instruction manual, may cause harmful interference to radio communications. Operation of this equipment in a residential area is likely to cause harmful interference in which case the user will be required to correct the interference at his own expense.

You are cautioned that any changes or modifications not expressly approved in this manual could void your authority to operate this equipment.

The shielded interface cable recommended in this manual must be used with this equipment in order to comply with the limits for a digital device pursuant to Subpart B of Part 15 of FCC Rules.

For the customers in Europe (for DXC-D35PK/D35PL/D35WSPL/D35PH)

This product with the CE marking complies with the EMC Directive (89/336/EEC) issued by the Commission of the European Community.

Compliance with this directive implies conformity to the following European standards:

- EN55103-1: Electromagnetic Interference (Emission)
- EN55103-2: Electromagnetic Susceptibility (Immunity)

This product is intended for use in the following Electromagnetic Environment(s):

E1 (residential), E2 (commercial and light industrial), E3 (urban outdoors) and E4 (controlled EMC environment, ex. TV studio).

Table of Contents

Chapter 1

Overview

Product Configurations	7
Features	9
Features on the DXC-D35/D35P/D35WSL/D35WSPL	9
Features on the DXC-D35WSL/D35WSPL	12
Location and function of Parts	13
Camera Head	13
VCL-918BY Zoom Lens	19
DXF-801/801CE Viewfinder	21

Chapter 2

Fitting and Connection

Replacing the Lithium Battery	23
Fitting a VTR	25
Using the Camcorder Grip	27
Fitting the Lens	30
Using Accessories	32
Using the Viewfinder	32
Using an Optional Microphone	33
Fitting to a Tripod	34
Using the Optional CAC-4 Chest Pad	34
Using the Carrying Case	35
Connections	36
Connecting a Portable VTR	36
Connecting a Number of Cameras (Using a Camera Control Unit)	37
Connecting a Number of Cameras (Without Using a Camera Control Unit)	39
Power Supply	40
Using Battery Packs	40
Camera Adaptor Power Supply	41

Chapter 3

Shooting

Basic Procedure for Shooting	43
Using the DynaLatitude Function	45
Shooting with the DSR-1/1P	46
Using the ClipLink Function	46
Using the Edit Search Function While Back Space Editing	48
Using the Freeze Mix Function	49

Chapter 4

Viewfinder Screen Indications and Menus

Viewfinder Screen Indications	51
Changing the Viewfinder Display	51
Viewfinder Normal Indications	54
Status Indications	57
Viewfinder Basic Menu	58
Basic Menu Operations	58
Contents and Settings of Each Page	58
Viewfinder Advanced Menu	64
Advanced Menu Operations	64
Contents and Settings of Each Page	64
Video Output and Viewfinder Picture (For DXC-D35WSL/D35WSPL)	70
Setup Files	71
Calling up a Setup File	71
Changing File Settings	73
Saving File Settings	73
Using SetupNavi and SetupLog with the DSR-1/1P	76
Setting up the Camera Using Data Recorded on Tape	76
Recording the Menu Settings onto a Tape	77
Viewing SetupLog Data	78

Table of Contents

Chapter 5

Adjustments and Settings

White Balance Adjustment	79
Saving an Appropriate White Balance Value in Memory	79
Using the Preset White Balance Settings	81
Light Sources and Color Temperatures	81
Using the ATW (Auto Tracing White Balance) Function	81
Black Balance Adjustment	83
Shutter Settings	84
Setting the Clock and Timestamping Recordings	86
Viewfinder Screen Adjustments	88
Adjusting the Lens	89
Flange Focal Length Adjustment	89
Iris Adjustments	90
Adjusting the Iris Sensitivity	91
Macrophotography	91
Settings for Special Cases	92
Skin Detail Correction	93
Adjusting Color in the Specified Area	93

Appendix

Important Notes on Operation	95
Characteristics of CCD Sensors	96
Warning Indications	97
Specifications	98
Related Products	99
Chart of Optional Components and Accessories	101
What Is ClipLink?	102
How ClipLink Changes Video Production Techniques ...	102
ClipLink Operation Flow	103
Example System Configuration	103
Data Generated When Shooting	104

Overview

Product Configurations

The eight models, DXC-D35K, DXC-D35L/D35WSL, DXC-D35H, DXC-D35PK, DXC-D35PL/D35WSPL, and DXC-D35PH, comprise both NTSC and PAL

versions and the components as shown in the figure on next page. The operation of the basic camera unit is the same in all cases.

Product Configurations

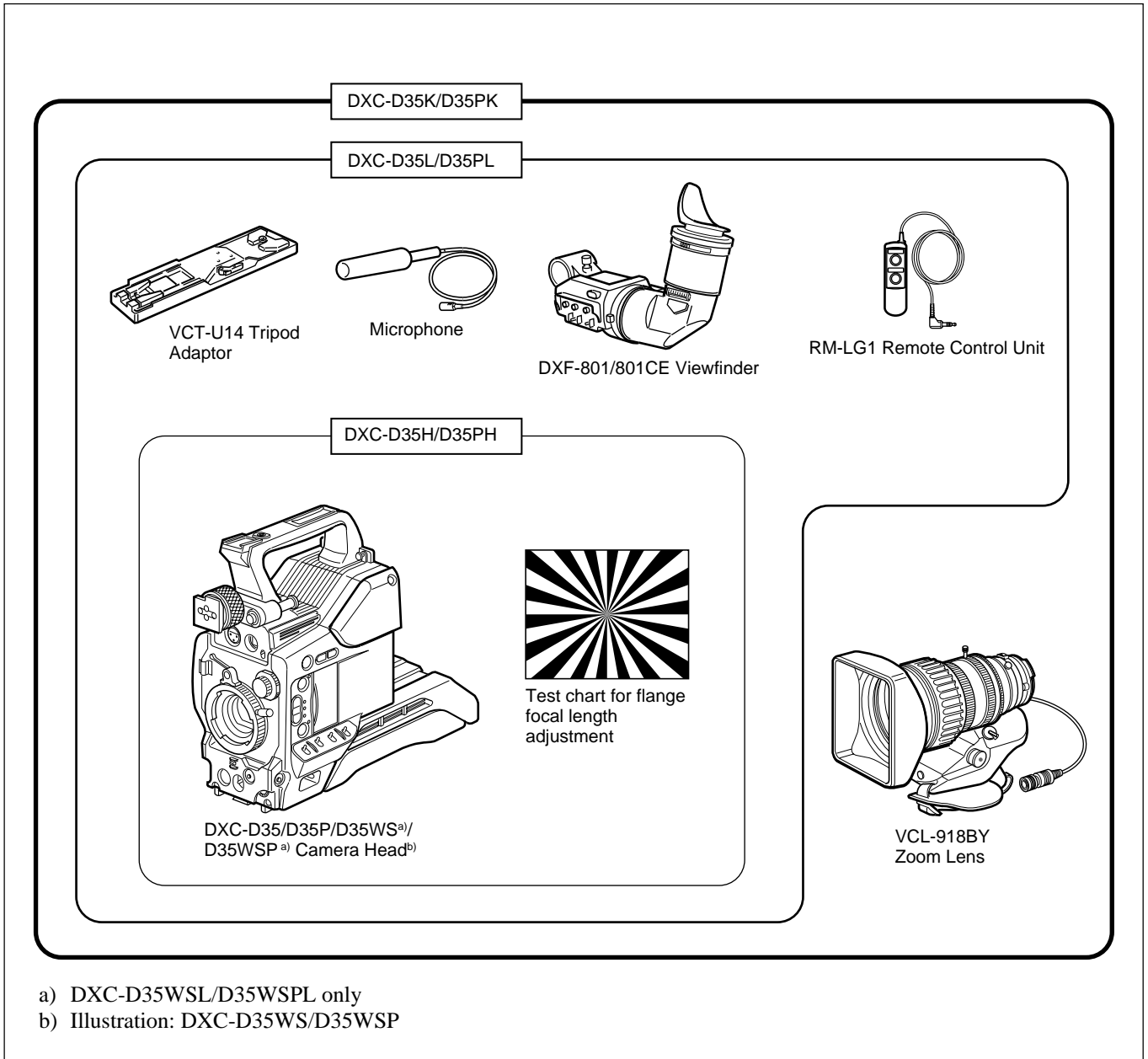

Camera adaptor

The product kit does not include a camera adaptor: to use a camera adaptor, you will need to purchase a model CA-537/537P or CA-327/327P.

Features on the DXC-D35/D35P/ D35WSL/D35WSPL

The DXC-D35WSL/S35WSPL is a 16:9 wide-screen type (4:3-16:9 switchable) digital video camera while the DXC-D35/D35P is a 4:3 standard-screen type digital video camera. Common features on both types are described in this section. See also “Features on the DXC-D35WSL/D35WSPL” (page 12) for using the DXC-D35WSL/S35WSPL.

2/3-inch IT type Power HAD (WS) CCD

The DXC-D35/D35P Color Video Camera uses 2/3-inch IT type Power HAD CCDs. (For the DXC-D35WSL/D35WSPL, Power HAD WS CCDs are used.) It outperforms most of the existing FIT type CCD cameras for high-end use, in both picture quality and sensitivity.

- Smear: -125 dB (DXC-D35/D35P) or -120 dB (DXC-D35WSL/D35WSPL)
- Sensitivity: F11.0 (at 3200 K, 2000 lux)
- S/N: 63 dB (DXC-D35/D35WSL) or 61 dB (DXC-D35P/D35WSPL)

Sophisticated image processing

TruEye™ processing makes possible the following performance features. This new digital signal processing has brought reproduction of natural colors to the level achieved by the human eye.

DynaLatitude™

Enables detailed adjustment of contrast control in each pixel in accordance with a histogram of luminance signal levels (see page 45).

DCC+ (dynamic contrast control plus)

Prevents white breakup when shooting a high intensity subject, and also prevents color faults in high intensity subject.

Black stretch and compress

Enables control of luminance signal levels in black areas without changing the hue.

Variety of detail corrections

- Skin detail function: this function gives a slightly softer appearance to the subject's face. The target skin color can be automatically set.
- Black halo correction
- Red/green vertical detail correction: this function performs vertical detail compensation for both red and green signals.
- Horizontal detail frequency control

Recording and managing setup data

In addition to the setup menu that is displayed in the viewfinder screen, the DXC-D35/D35P/D35WSL/D35WSPL is equipped with the following functions to facilitate camera head setup.

Setup file system

You can use setup files when making adjustments or settings. The DXC-D35/D35P/D35WSL/D35WSPL comes with factory preset files that contain shipped settings and you can freely create user files as well.

Automatic recording of setup data (when using DSR-1/1P)

When the DXC-D35/D35P/D35WSL/D35WSPL is connected to the DSR-1/1P VTR, two types of setup data can be recorded.

SetupLog™: Shooting-related environment settings are recorded onto the tape at intervals of a few seconds. This recorded data can then be used to reproduce the same shooting conditions in subsequent shots. It also makes it easier to identify the causes of problems in previous shots.

SetupNavi™: The setup conditions selected with the setup menu and setup files are recorded onto the tape. The recorded setup data can be copied to other camera heads so that the same setup can be shared among several camera heads.

ClipLink™ Function (when using DSR-1/1P)

The ClipLink function can be used at every step from acquisition to editing. Information necessary for editing is recorded when shooting to ensure fast and efficient editing operations.

When you set a recording start (Rec IN) point or when you press the TAKE button to set a Mark IN point, the video image at that point is recorded on the tape in compressed form as an Index Picture. In addition, the time codes for such editing points (Mark IN/Mark OUT points or cue points) are recorded along with other editing point data (such as the cassette number and scene number) into cassette memory (as ClipLink log data). Unsuccessful scenes containing faults can also be marked in cassette memory as “NG”, so that only the good scenes are taken up from cassette memory when editing.

Dockable with various types of VTRs

The DXC-D35/D35P/D35WSL/D35WSPL docks with the DSR-1/1P DVCAM VTR to configure a digital camcorder. It also docks with the PVV-3/3P Betacam SP VTR to configure a Betacam SP camcorder. In addition, the DXC-D35/D35P/D35WSL/D35WSPL docks with the EVV-9000/9000P Hi-8 VTR. Using an adaptor (not supplied), it is also able to dock with a variety of existing S-VHS VTRs.

New Functions boost operability

EZ (easy) mode function

When there isn't time to check the camera head settings, simply press the EZ mode button to start the auto adjustment function using standard settings. There is no need to lose a shot for lack of setup time.

EZ (easy) focus

Press the EZ focus button before shooting to ensure a quick and accurate focus.

Programmable gain

The amount of gain relative to the GAIN switch setting (H, M, or L) can be programmed as -3 dB, 0 dB, 3 dB, 6 dB, 9 dB, 12 dB, 18 dB, 18 dB+DPR¹⁾, 24 dB, 24 dB+DPR and hyper gain.

Hyper gain

Hyper gain (36 dB or 42dB, i.e. about 60 times or 120 times greater than 0 dB) can be easily set via one switch setting. This can also be done from remote equipment.

Auto tracing white balance

This function automatically traces the white balance, which constantly changes as lighting conditions change. Auto tracing white balance is especially useful when there is no time to manually adjust the white balance or when shooting moves between indoor and outdoor locations.

Total level control system (TLCS)

Even if the incoming light exceeds the range in which the standard auto iris can control exposure, the auto gain control (AGC) or auto exposure (AE) backs up to ensure proper exposure.

Dual pixel readout (DPR)

When the gain is set to either 18 dB or 24 dB, the gain setting can be doubled (6 dB up) without increasing the noise level.

Recording time display

Recording time can be displayed in either of the following modes.

- Total recording time for all cuts
- Total recording time for current cut

Viewfinder super detail

Video signals for the viewfinder are mixed with DTL signals to make focusing easier.

1) DPR = Dual Pixel Readout

Dual zebra pattern display

Two types of zebra patterns, zebra 1 and zebra 2 can be displayed simultaneously or independently. The zebra 1 can be set to the levels ranging from 70 to 90 IRE on the DXC-D35/D35WSL (or from 70 to 90% on the DXC-D35P/D35WSPL) and the zebra 2 indicates the levels of 100 IRE for the DXC-D35/D35WSL or more (or the levels of 100% or more for the DXC-D35P/D35WSPL).

Color temperature display

When reading the white balance, the color temperature is displayed on the viewfinder screen.

Switching the color temperatures for the preset white balance

You can select the preset white balance at 3200 K (default) or 5600 K (default) by setting the FILTER control. The preset white balance can be changed to other value through menu setting (*see page 59*).

Video monitor output with text

The video signal with text superimposed that is shown in the viewfinder can also be output to an external video monitor.

Camera head microphone output indicator

An indication \downarrow appears in the viewfinder whenever a signal is being output from the camera head's microphone.

1-kHz reference signal output

Along with a color bar, a 1-kHz reference signal can also be output.

Freeze mix function (when using DSR-1/1P)

The freeze mix function superimposes any previously recorded still picture on the viewfinder screen to facilitate framing the subject when reshooting the scene.

Edit Search Function (when using DSR-1/1P)

When using the DXC-D35/D35P/D35WSL/D35WSPL with the DSR-1/1P, pressing the EDIT SEARCH buttons allow the tape to play back in search mode. Set either of two playback speeds.

Designed for ease of operation

Dynafit Pad

Thanks to the Dynafit Pad which fits well to the shoulder, the camera is stable on the shoulder.

Slide cover

The slide cover can hide the switches and buttons that are seldom used during shooting. The cover can be locked so as not to open during shooting.

High-performance viewfinder (DXF-801/801CE)

- High resolution (600 TV lines of horizontal resolution)
- Large-diameter eye cup for easier viewing and focusing
- PEAKING potentiometer for vertical and horizontal detail control
- Two indicators can be used as TALLY indicators.
- Tough die-cast aluminum body
- DISPLAY switch that can turn the character display on and off
- Light that can light the lens control elements
- Switching the aspect ratio automatically between 16:9 (wide screen) and 4:3 (standard screen) when used with the DXC-D35WSL/D35WSPL

VTR data display

When connected to a VTR, the DXC-D35/D35P/D35WSL/D35WSPL is able to display the following data on the viewfinder screen.

- Time values (counter, time code, or user bit vales)
- VTR audio levels
- Remaining tape time
- VTR operation mode
- Remaining battery capacity (when using an Anton Bauer Intelligent Battery System)
- ClipLink information (when using the DSR-1/1P)

Features on the DXC-D35WSL/ D35WSPL

Features only on the DXC-D35WSL/S35WSPL is described in this section. See “Features on the DXC-D35/D35P/D35WSL/D35WSPL” (page 9) for common features on a 4:3 standard-screen type digital video camera and 16:9 wide-screen type digital video camera.

Switchable between 16:9 and 4:3 aspect ratios

A simple menu operation provides instant switching between the 16:9 and 4:3 aspect ratios. In 4:3 mode, a screen equivalent to a 4:3 screen is obtained through digital processing of the 16:9 video signals produced by the WS CCD. (See page 68.)

Wide-aspect ID signals

A menu setting is available to add wide-aspect ID signals¹⁾ to 16:9-mode video signals.²⁾ (See page 68.)

Selection of the safety zone size in 16:9 mode

When the aspect ratio is 16:9, you can change the safety zone size through menu setting (see page 65.)

1) ID signals complying with EIAJ CPR-1204 (DXC-D35WSL) or complying with ETS WSS (DXC-D35WSPL).

2) Video signals refer to the following:

- Video signals output from the VIDEO OUT connector and MONITOR OUT connector.
- The Y component of Y/C separate signals and the Y component of component signals output from the VTR connector.

Location and Function of Parts

Camera Head

Right side view

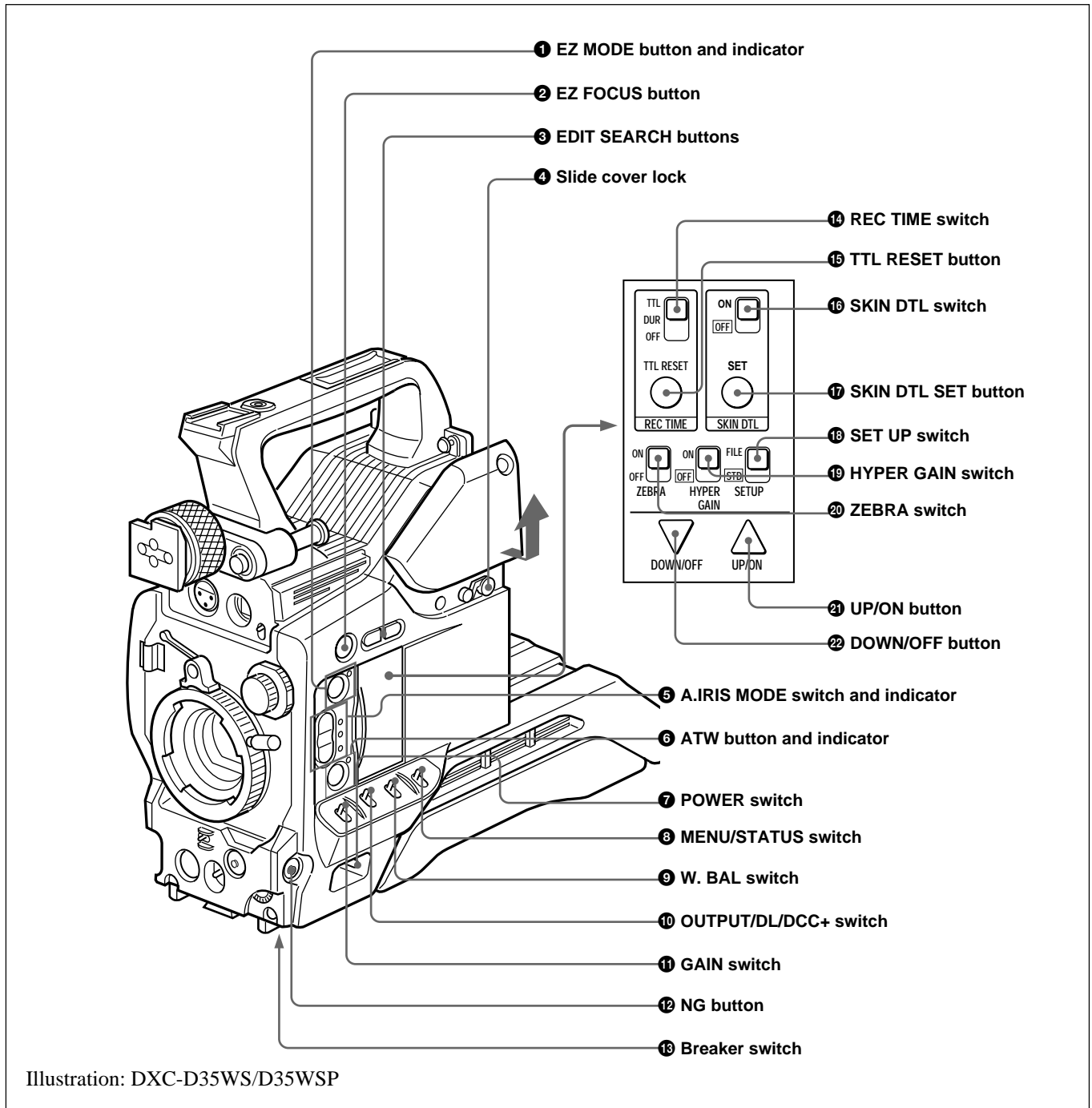

Location and Function of Parts

1 EZ (“easy”) MODE button and indicator

Depress this button (EZ mode on) when you want to be able to shoot immediately, with automatic adjustment of the camera settings to standard values. (See page 68.) When this function is used, the iris and the white balance are adjusted automatically. (The total level control system functions.) Press this button again to return the camera to the previous settings (EZ mode off).

Note

When connecting the CCU-M5/M7 (or CCU-M5P/M7P) Camera Control Unit or the RM-M7G Remote Control Unit, the “easy mode” function is disabled.

2 EZ FOCUS button

Press this button to turn the “easy focus” function on. This opens the iris, to make it easier to focus before beginning shooting. The indication “EZ FOCUS” appears in the viewfinder while the function is on; to turn it off, press the EZ FOCUS button again. If left on, the function automatically turns off after about ten seconds.

Note

If the “easy focus” function is still on when you press the VTR button, it turns off automatically and recording starts about one second later.

3 EDIT SEARCH buttons (for operation with DSR-1/1P)

When using the DSR-1/1P to record, you can see the search playback while pressing either of these buttons at recording pause mode to quickly find the next recording start point. Two playback speeds are available, and press either of the buttons to the inner position to increase the speed.

4 Slide cover lock

This lock keeps the slide cover closed.

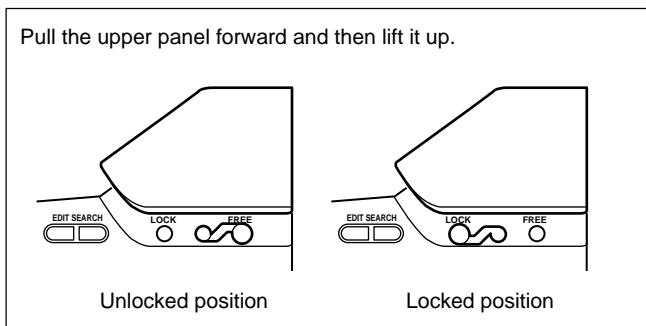

5 A.IRIS (auto iris) MODE switch and indicator

When you use the auto iris function (by setting the iris selector on the lens to A), set this switch to suit the shooting conditions. Selecting BACK L gives more light to back-lit subjects, and selecting SPOT L adjusts for high contrast in spot-lit subjects. For normal shooting, set this switch to STD.

6 ATW (auto tracing white balance) button and indicator

Press this button, turning the indicator on, when you want the white balance to be adjusted automatically to follow changes in lighting conditions. (See page 81.)

7 POWER switch

This powers the camera on and off. There are two different ON settings as follows.

ON STBY: This puts the VTR on standby. In this state, pressing the VTR button on the camera head, the lens or a camera adaptor starts recording immediately.

ON SAVE: This puts the VTR in the power-saving state, with the video head drum stationary. In this state, it takes a few seconds to start recording after pressing the VTR button.

Note

The VTR state when this switch is in the ON STBY or ON SAVE position may depend on the VTR model.

8 MENU/STATUS switch

When you press this switch to the MENU position, the basic menu is displayed. Keep pressing it to the MENU position to cycle through the various menu displays. When you press the switch to the STATUS position, the DXC-D35/D35P/D35WSL/D35WSPL's status (of current settings) is displayed.

9 W. BAL (white balance) switch

This selects the white balance setting from the preset value, the value in memory A or the value in memory B. (See page 79.)

10 OUTPUT/DL/DCC+ (DynaLatitude/dynamic contrast control plus) switch

Use this switch to select the DCC+ function, the DynaLatitude function, or color bar output. Select the CAM/DCC+ position in most cases.

CAM/DCC+: This activates the DCC+ function. This prevents color faults when shooting high-intensity subjects.

CAM/DL: This setting uses the DynaLatitude function, which finely adjusts the contrast of each pixel according to a histogram of luminance signal levels. Access advanced menu page 2 to set the DynaLatitude function ON or OFF. The DynaLatitude effect can be set to any of three levels, Low, STD (standard), and High with basic menu page 2.

BARS: This setting displays color bars.

For details of menu operation, see Chapter 4 “Viewfinder Screen Displays and Menus” (page 51).

11 GAIN switch

This selects one of the three gain settings, high, medium or low. You can choose the gain values assigned to the H, M and L settings from values from -3 dB to 24 dB + DPR and HYPER GAIN. (See page 64.) The factory default selections are 18 dB (H), 9 dB (M) and 0 dB (L).

Note

When the HYPER GAIN switch 19 is in the ON position, the GAIN switch has no effect.

12 NG button

When using the ClipLink function during shooting, you can designate a particular scene as “NG” (No Good) by pressing this button before shooting the next scene. Press the button again to cancel the NG setting.

13 Breaker switch

If there is a fault in the camera power supply, the breaker trips, and the camera power supply is disconnected. Correct the fault in the power supply, then press this switch.

14 REC (recording) TIME switch

This selects the recording time indication in the viewfinder.

TTL: Displays the total recording time.

The total recording time is not reset even when you stop the VTR and power off the camera, for example, to replace the battery pack.

DUR: Displays the recording time of the current cut.

OFF/TC: Switches off the recording time display.

If, however, a PVV-3/3P is connected, and in the advanced menus you set the time code display item (TC IND) to ON (see page 67), then the VTR time data (time code, CTL count, or user bit value) is displayed.

Note

The recording time displayed when this switch is set to the TTL or DUR position is obtained by counting the duration of the internal reference signal input to the camera.

The value may not agree exactly with the value derived from the time code values. Furthermore, the value displayed may not be correct when another manufacturer’s VTR is connected to the camera.

15 TTL (total) RESET button

Pressing this button resets the total recording time (TTL selection) to zero.

16 SKIN DTL (skin detail) switch

Set this switch to ON to use the skin detail correction function.

For details, see “Skin Detail Correction” (page 93).

17 SKIN DTL (skin detail set) SET button

Press this button with the SKIN DTL button 16 to display the area detect cursor on the viewfinder screen. Place the cursor on the target and press this button to perform skin detail correction.

For details, see “Skin Detail Correction” (page 93).

18 SET UP switch

Use this switch to select the camera head setup method.

STD: Set up using the setup menu. Setup file data is not displayed.

FILE: Set up using setup files and the setup menu.

19 HYPER GAIN switch

Setting this switch to the ON position increases the gain by a factor of about 60 or 120 with respect to 0 dB (a 30 or 36 dB increase by electronic amplification and a 6 dB increase for DPR, bringing about a total gain increase of 36 or 42 dB).

When this switch is in the ON position, the indication “HYPER” appears in the viewfinder, and the GAIN UP indicator in the viewfinder also lights.

When finished shooting, return this switch to the OFF position. The “HYPER” indication disappears and the GAIN UP indicator goes out.

Note

Increasing the gain with this switch reduces the horizontal resolution by 50%.

Location and Function of Parts

20 ZEBRA switch

Set this switch to the ON position to display a zebra pattern (diagonal stripes) in the viewfinder.

Depending on the zebra setting in advanced menu page 4 (page 65), the zebra 1 for video levels between 70 to 90 IRE (or 70 to 90%) and the zebra 2 for video levels 100 IRE or more (or 100% or more) can be displayed independently or simultaneously.

21 UP/ON button

Use this button to open displays and to make “ON” settings. When using the advanced menus, use this button to change menu pages or to switch to the ordinary screen display.

22 DOWN/OFF button

Use this button to close displays and to make “OFF” settings. You can also use this button to change menu pages when using the advanced menus.

Front view

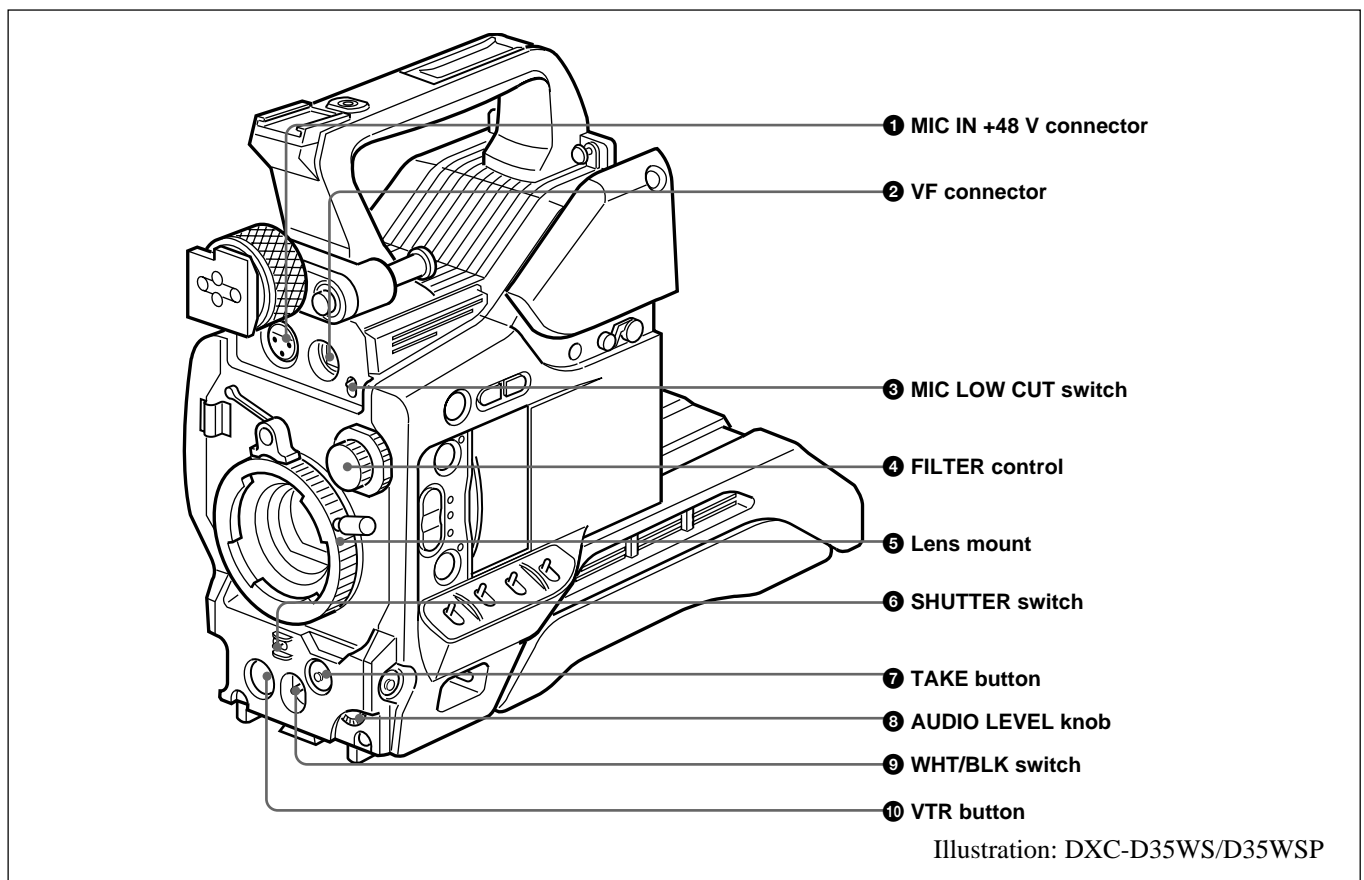

1 MIC (microphone) IN +48 V connector (XLR 3-pin, female)

Connect the supplied microphone or an optional microphone (operable with a 48 V supply).

2 VF (viewfinder) connector (20-pin)

This is the connector for the DXF-801/801CE viewfinder.

Note

When using this connector, do not connect a DXF-41/51 viewfinder to the VF connector on the left side.

3 MIC LOW CUT switch

Set this switch to the ON position to insert a high-pass filter in the microphone circuit, reducing wind noise. Normally leave the switch in the OFF position.

4 FILTER control

Select the color temperature conversion filter appropriate to the lighting conditions. (See page 43.)

5 Lens mount

Attach the zoom lens here.

6 SHUTTER switch

Use this switch to set the shutter speed, CLS (clear scan), or EVS setting (*see page 84*). Usually, set this switch to OFF.

7 TAKE button

Press this button to specify an editing point (Mark IN/OUT or cue point) at the current tape position during shooting.

8 AUDIO LEVEL knob

When the DSR-1/1P is attached, you can use this knob to manually adjust the channel 1 audio recording level.

9 WHT/BLK (white/black) switch

This switch is used for automatic adjustment of the white balance and black balance. (*See pages 79 to 83.*)

10 VTR button

Pressing this button starts and stops recording on the VTR.

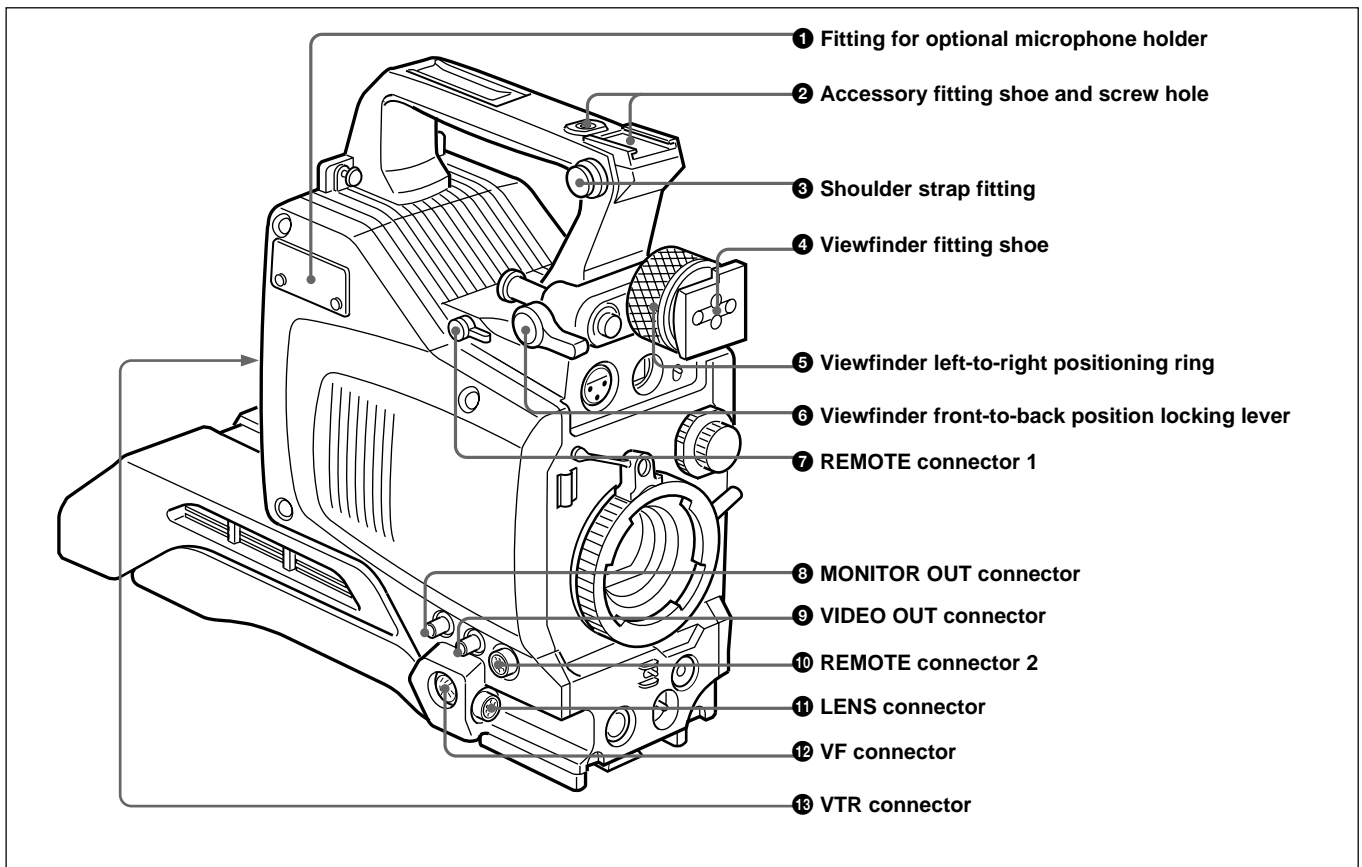
Left and upper view**1 Fitting for optional microphone holder**

You can fit an optional CAC-12 Microphone Holder here. (*See page 33.*)

2 Accessory fitting shoe and screw hole

Attach optional video lights or other accessories here.

3 Shoulder strap fixture

To use the supplied shoulder strap, fix one end here and the other end to the VTR.

4 Viewfinder fitting shoe

Fix the DXF-801/801CE Viewfinder here.

5 Viewfinder left-to-right position fixing ring

Loosen this ring to adjust the left-to-right position of the viewfinder. (*See page 32.*)

6 Viewfinder front-to-back position locking catch

Release this catch to adjust the front-to-back position of the viewfinder. (*See page 32.*)

Location and Function of Parts

7 REMOTE connector 1 (mini-jack)

Connect the RM-LG1 Remote Control Unit to enable remote operation of the ClipLink function.

8 MONITOR OUT connector (BNC)

Outputs both the camera video and the character information as displayed on the viewfinder screen. You can connect an optional LCD color monitor to this connector.

9 VIDEO OUT connector (BNC)

This outputs the video signal captured by the camera.

10 REMOTE connector 2 (10-pin)

Connect the optional RM-M7G Remote Control Unit to this connector. Set the CAMERA HEAD SELECT switch on the bottom of RM-M7G to 1.

Note

When using the RM-M7G, note the following points.

- When operating the camera head from the camera control unit, connect the RM-M7G to the camera control unit.
- EZ mode cannot be used if the RM-M7G is connected to the camera head.

11 LENS connector (12-pin, for 2/3-inch lens)

Connect the lens connector.

12 VF (viewfinder) connector (8-pin)

This is the connector for the DXF-41/51 viewfinder.

Note

When using this connector, do not connect a DXF-801/801CE viewfinder to the VF connector on the front of the camera head.

13 VTR connectors (PRO 76-pin DIGITAL and PRO 50-pin)

Connect a dockable VTR. A PRO 76-pin DIGITAL connector is for the DSR-1/1P and a PRO 50-pin connector is for the PVV-3/3P or a camera adaptor.

VCL-918BY Zoom Lens

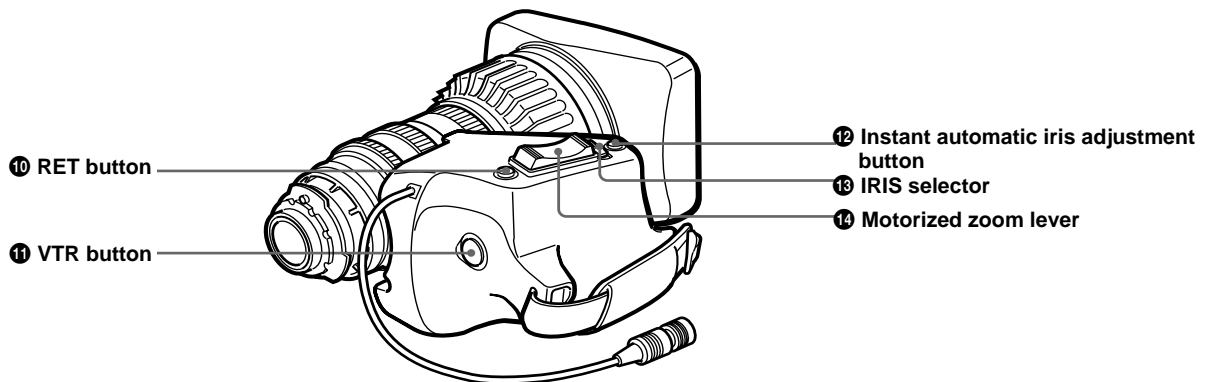
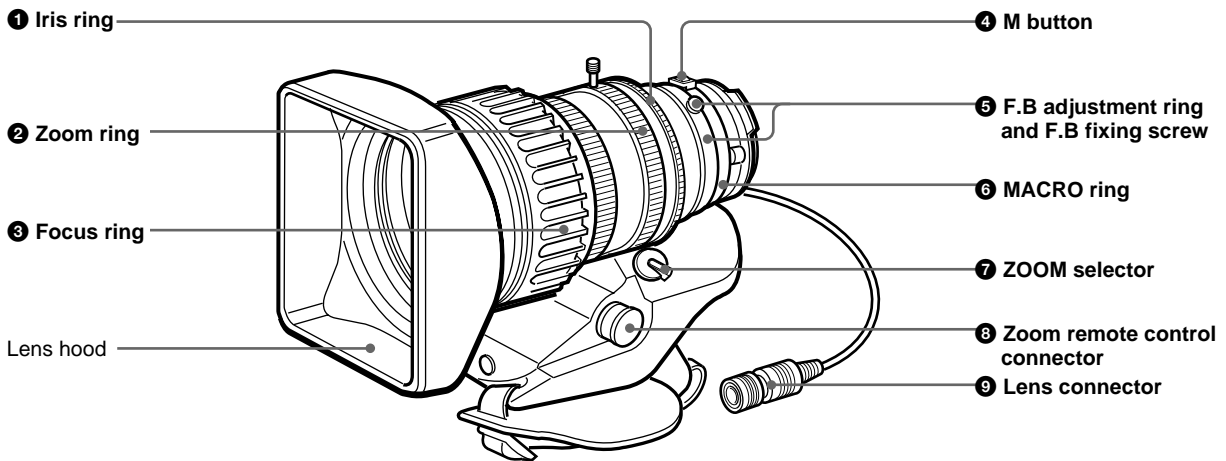

Location and Function of Parts

1 Iris ring

For manual iris control, set the IRIS selector 13 to the “M” position, and turn this ring.

2 Zoom ring

For direct manual zoom control, set the ZOOM selector 7 to the “MANU.” position, and turn this ring.

3 Focus ring

Turn this ring to focus the lens on the subject.

4 M (close-up) button

For close-up work, turn the MACRO ring 6 while holding this button down. (See page 91.)

5 F.B (flange focal length) adjustment ring and F.B fixing knob

F.B adjustment ring : To adjust the flange focal length, loosen the F.B fixing knob, then turn the ring. (See page 89.)

F.B fixing knob: Fixes the F.B adjustment ring.

6 MACRO (close-up) ring

For close-up, turn this ring while holding the M button 4 down. (See page 91.)

7 ZOOM selector

This selects the mode of zoom operation.

SERVO: power zoom

MANU. (manual): manual zoom

8 Zoom remote control connector (8-pin)

Connect the optional LO-26 lens remote control unit for remote control of zooming.

9 Lens connector (12-pin)

Connect to the LENS connector (11 on page 18) of the Camera Head.

10 RET (return) button

This allows you to check the video signal as follows.

When operating with a portable VTR connected via other equipment: when the VTR is in

recording, pressing this button connects the E-E video signal1) from the VTR to the viewfinder.

When operating with a DSR-1/1P or PVV-3/3P mounted on the camera head: when the VTR is in recording pause mode, press this button to review the last few seconds of the recording in the viewfinder (recording review).

When operating with a CCU-M5/M5P/M7/M7P Camera Control Unit connected: pressing this button connects the return video signal from the camera control unit to the viewfinder.

When this button is not pressed, the viewfinder displays the video signal captured by the camera.

11 VTR button

When operating with a VTR: this button starts and stops recording, and once more to stop.

When operating with a CCU-M5/M5P/M7/M7P Camera Control Unit connected: pressing this button connects the return video signal from the camera control unit to the viewfinder.

(Starting and stopping recording is controlled on the VTR.)

12 Instant automatic iris adjustment button

While using manual iris control, press this button to switch temporarily to the automatic iris control setting. The automatic setting is maintained as long as you hold the button down.

13 IRIS selector

This selects the mode of iris operation. (See page 14.)

A (automatic): automatic iris

M (manual): manual iris

14 Motorized zoom lever

Use this to carry out a power zoom. Pressing the lever harder increases the zoom speed.

W end: zoom toward wide angle

T end: zoom toward telephoto

1) **E-E video signal:** “electric-to-electric” video signal. This is the input video signal which has passed through internal electrical circuits, but has not been converted to a magnetic signal.

DXF-801/801CE Viewfinder

You can switch the scan size of the DXF-801/801CE in accordance with the aspect ratio selected on the camera or camcorder.

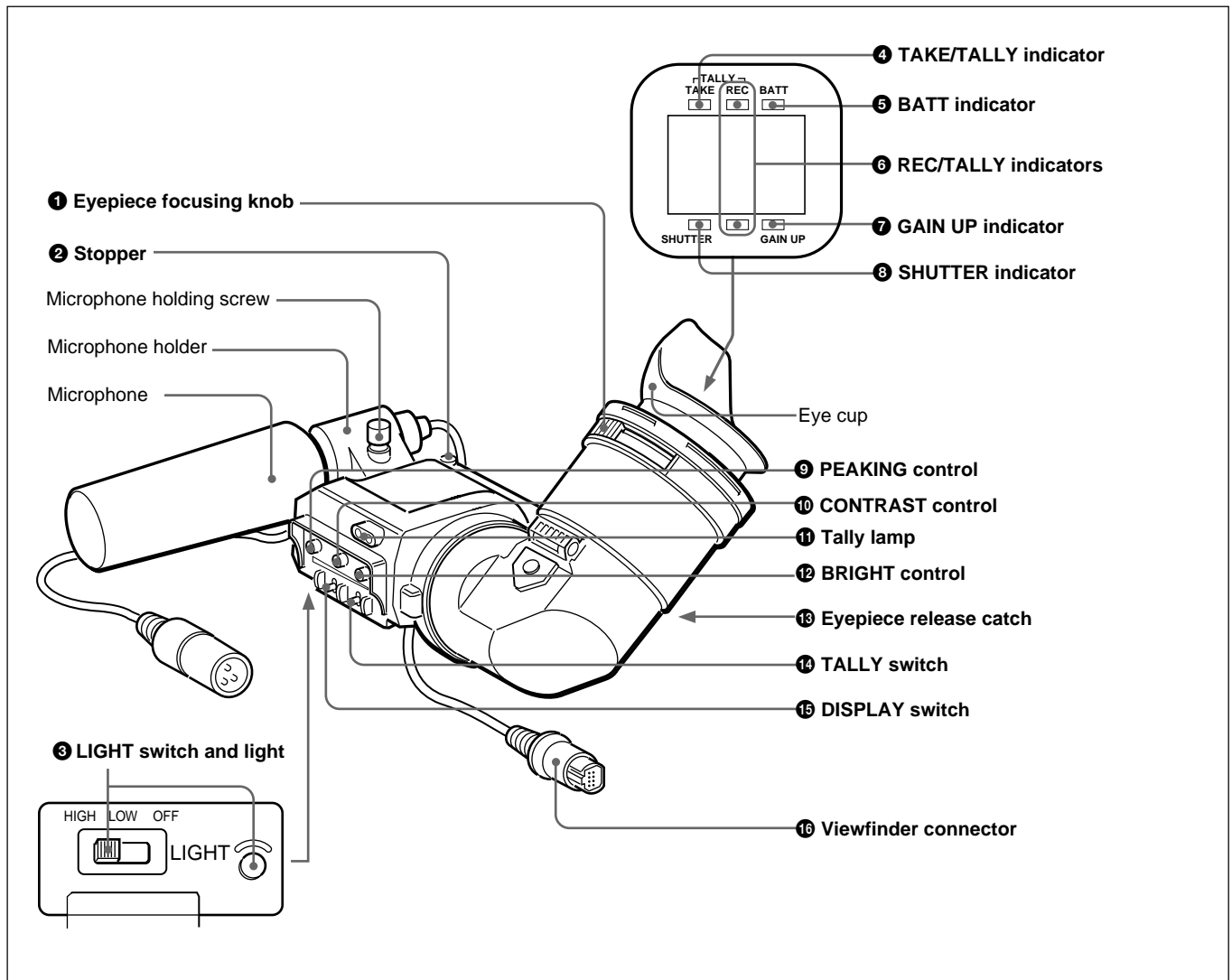

1 Eyepiece focusing knob

Turn this to adjust the viewfinder focus to match your eyesight. (See page 88.)

2 Stopper

Lift up when detaching the viewfinder (See page 32).

3 LIGHT switch and light

The light lights the lens and the switch controls the light as follows.

HIGH/LOW: Turn the light on and control the brightness.

OFF: Turns the lights off.

4 TAKE/TALLY indicator (orange)

When using the ClipLink function while shooting, this indicator lights when the TAKE button (7 on page 17) has been pressed to set a Mark IN point and goes out when a Mark OUT point is set.

5 BATT (battery) indicator (red)

This lights when the battery capacity is low.

Note

When using a camera control unit, this indicator flashes when you operate the controls, but this is not a malfunction.

Location and Function of Parts

⑥ REC/TALLY (recording/tally) indicators (red)

- This flashes from the time when you press the VTR button (⑩ on page 17 and ⑪ on page 20) on the lens or camcorder until recording starts, then stays on continuously during recording.
- When using a camera control unit, this lights when the video from the camera is selected.
- This is also used to indicate a fault. (See page 97.)
- The lower indicator can be disabled by menu setting. (See page 66.)

⑦ GAIN UP indicator (orange)

This lights when the gain is 3 dB or more.

⑧ SHUTTER indicator (red)

This lights when the SHUTTER switch (⑥ on page 17) is in the ON position. (If the EVS is selected, the indicator will not light.)

⑨ PEAKING control

This adjusts the outline intensity of the viewfinder image. (See page 88.)

⑩ CONTRAST control

This adjusts the contrast of the viewfinder image. (See page 88.)

⑪ Tally lamp

When the TALLY switch ⑭ is in the ON position, this operates in the same way as the REC/TALLY indicators ⑥.

⑫ BRIGHT (brightness) control

This adjusts the brightness of the viewfinder image. (See page 88.)

⑬ Eyepiece release catch

To view the viewfinder screen directly, press this catch, and hinge up the eyepiece.

⑭ TALLY switch

Set this switch to the ON position to use the tally lamp ⑪.

⑮ DISPLAY switch

Set this switch to OFF when you want to remove the character data from the viewfinder and the monitor connected to the MONITOR OUT connector. However, items which are set to OFF in advanced menu page 5 and page 6 are not displayed even when this switch is set to ON.

⑯ Viewfinder connector (20-pin)

Connect this to the VF connector (② on page 16).

Fitting and Connections

Replacing the Lithium Battery

The camera head uses a lithium battery (CR2032) to retain date and time data.

When the lithium battery's voltage falls, the clock indication does not appear. Replace the lithium battery and set the clock (*see page 86*).

Notes

- Carefully read the instructions for replacing the lithium battery. **Lithium batteries may explode if misused.**
- Use only CR2032-type lithium batteries. Other types of lithium batteries may come loose when the camcorder is moved. If you have difficulty finding CR2032-type lithium batteries, contact your Sony dealer.

Replacing the Lithium Battery

- 1 Pull the upper part of the battery cover (on the rear of the camera head) forward and turn the cover clockwise.

For detaching the VTR or camera adaptor, see “Fitting a VTR” next page.

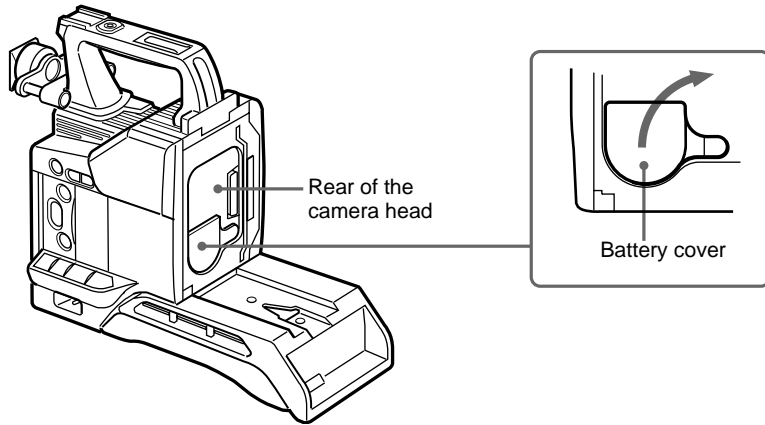

- 2 Take out the lithium battery.

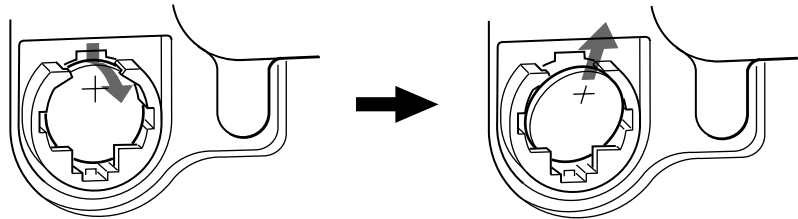

Press down and pull out toward you.

- 3 Reverse step 2 to insert a replacement lithium battery. Make sure that the **+** symbol on the battery is facing you.

- 4 Close the battery cover.

Fitting a VTR

This section explains how to attach the DSR-1/1P to the camera head. The method for attaching a PVV-3/3P is similar.

When replacing the camera head grip with a camcorder grip, see “Using the Camcorder Grip” (page 27).

- 1 Set the PRO 76-pin DIGITAL connector on the DSR-1/1P. (The camera connector on the PVV-3/3P is PRO 50-pin.)

For details, see the operating instructions for the DSR-1/1P.

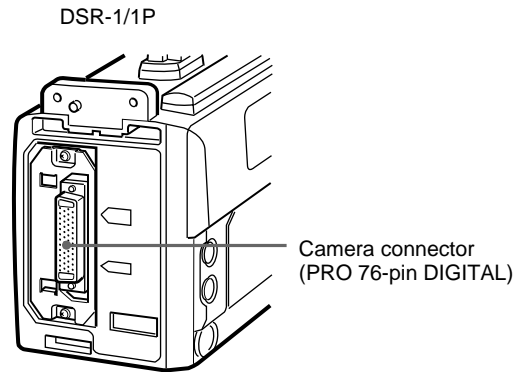

- 2 Loosen the two screws and remove the shoulder pad.

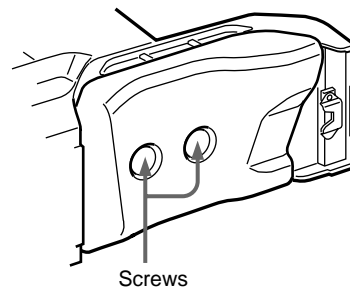

- 3 Align the projection on the bottom of the DSR-1/1P with the slot on the camera head.

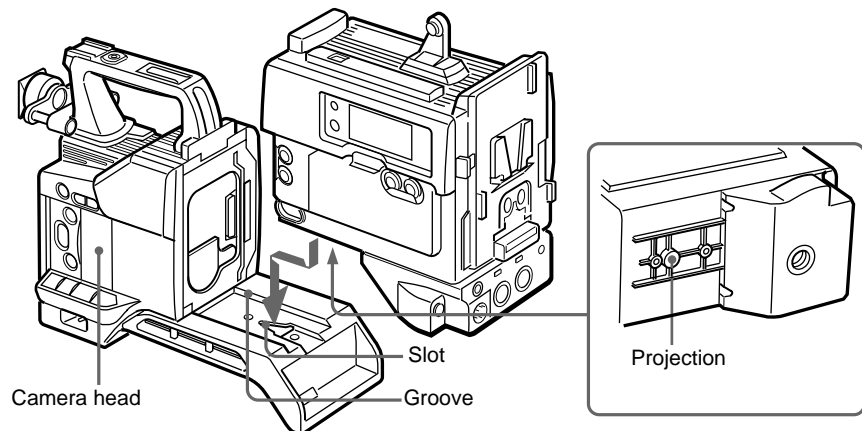

(continued)

Fitting a VTR

- 4** Slide the DSR-1/IP and the camera head together in the groove as far as possible.

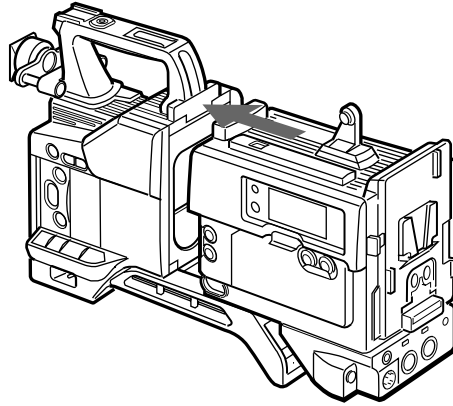

- 5** Tighten the two screws in the grip connector and the two screws in the shoulder pad section.

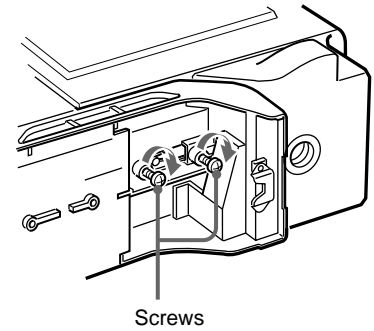
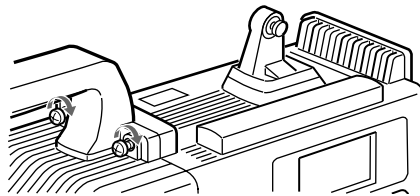

- 6** Attach the shoulder pad.
-

To remove the VTR

Reverse the fitting procedure.

To fit a camera adaptor

Follow the same procedure as when fitting a VTR.

Using the Camcorder Grip

When using the camera head with a VTR as a camcorder, you can replace the camera head's grip with a camcorder grip (not supplied). The type of

camcorder grip and the method for attaching it differ slightly depending on the type of VTR.

Attaching a camcorder grip to the DSR-1/1P

- 1 If the viewfinder is attached, adjust the viewfinder to the full-forward position.

For details, see "Adjusting the viewfinder position" on page 32.

- 2 Remove the camera head grip's three screws, then pull up the grip to remove it.

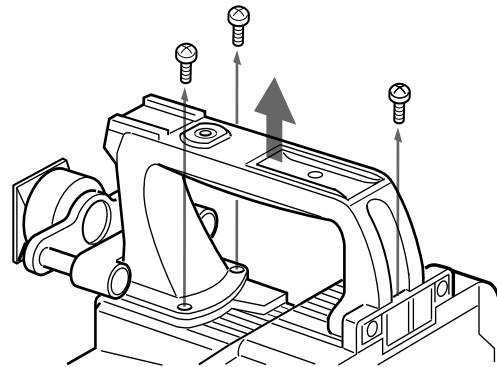

- 3 Remove the VTR connection plate.

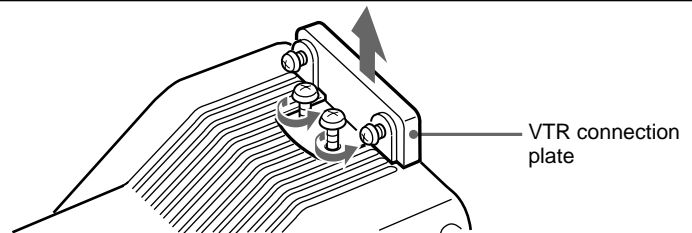

- 4 Remove the DSR-1/1P's shoulder strap fitting and the camera head connection plate.

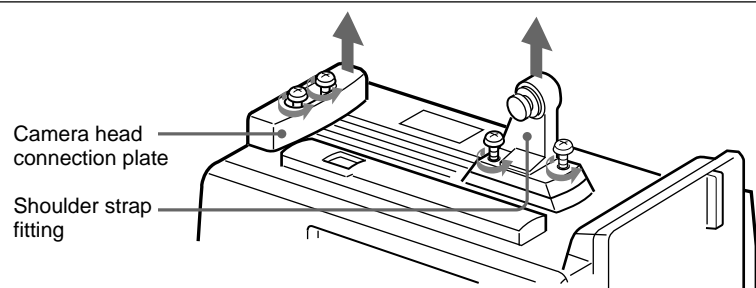

(continued)

Fitting a VTR

5 Perform the first three steps in “Fitting a VTR”.

6 Screw the connection plate (supplied with the grip for the DVCAM camcorder) which straddles the connection between the camera head and the DSR-1/1P. Also, tighten the two screws in the shoulder pad section. (See step **5** on page 26.)

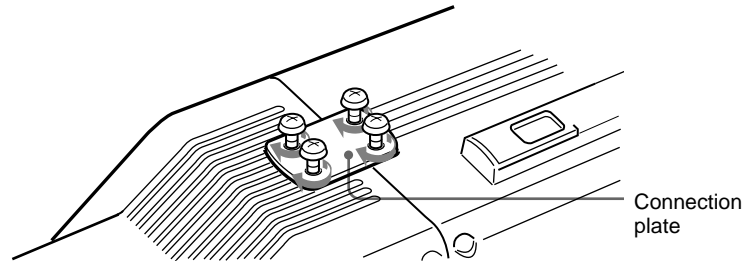

7 Screw the grip for the DVCAM camcorder.

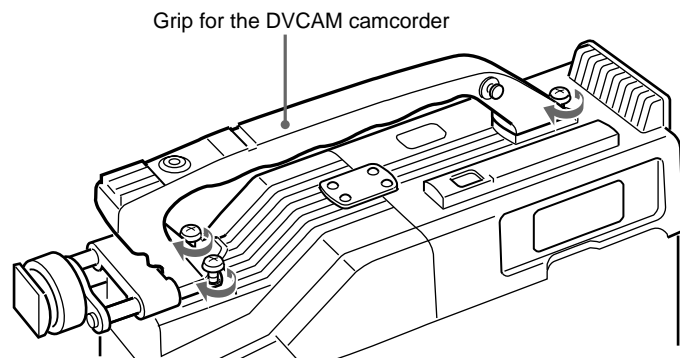

Attaching a camcorder grip to the PVV-3/3P

1 Perform steps **2** to **4** in “Fitting a VTR”.

2 If the viewfinder is attached, adjust the viewfinder to the full-forward position.

For details, see “Adjusting the viewfinder position” on page 32.

- 3** Remove the grip's three screws, then pull up the grip to remove it.

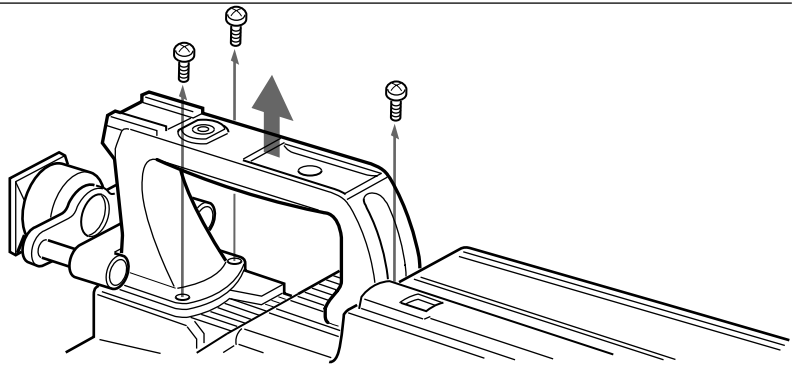

- 4** Remove the PVV-3/3P's shoulder strap fitting.

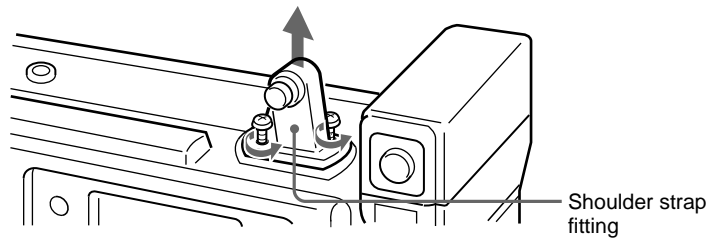

- 5** Screw the grip for the Betacam camcorder.

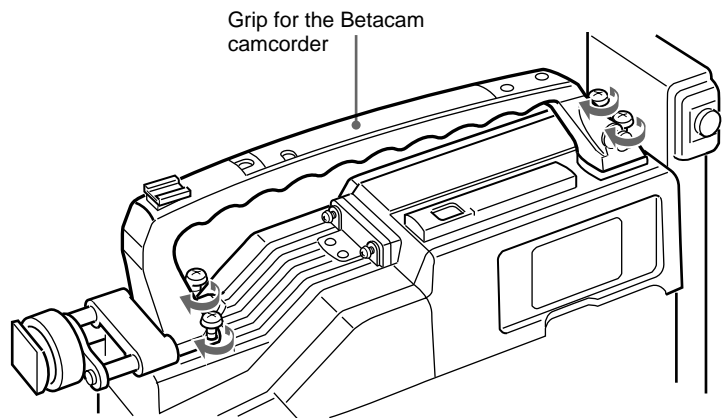

Fitting the Lens

In the case of the DXC-D35K/D35PK model, the lens is already fitted. In other cases, use the following procedure to fit the lens.

- 1 Remove the retaining rubber which prevents the lens mount from coming loose, then raise the lens fixing lever, and remove the lens mount cap.

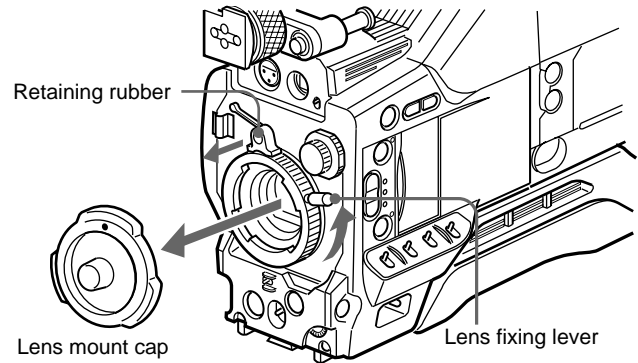

- 2 With the lens fixing lever turned fully counterclockwise, push in the lens, aligning the projection on the lens with the cutout on the camera.

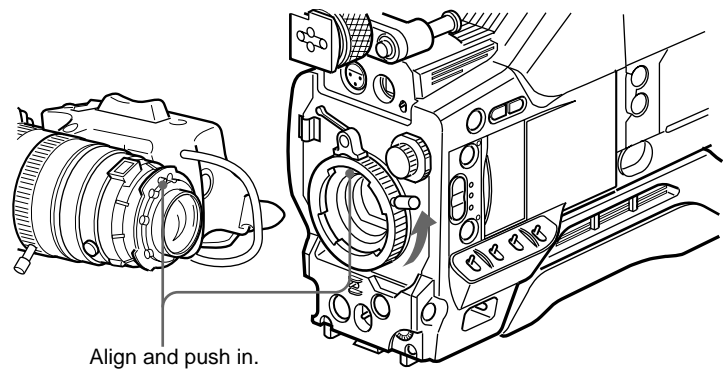

- 3 Supporting the lens, turn the lens fixing lever fully clockwise. Replace the retaining rubber on the lens mount.

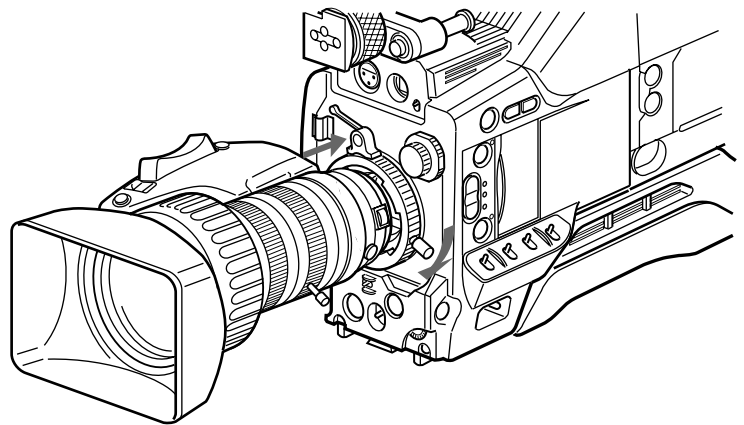

- 4** Using the triangular mark as a guide, push the lens connector into the LENS connector on the camera head, until it clicks into place. Fasten the cable with the clamps.

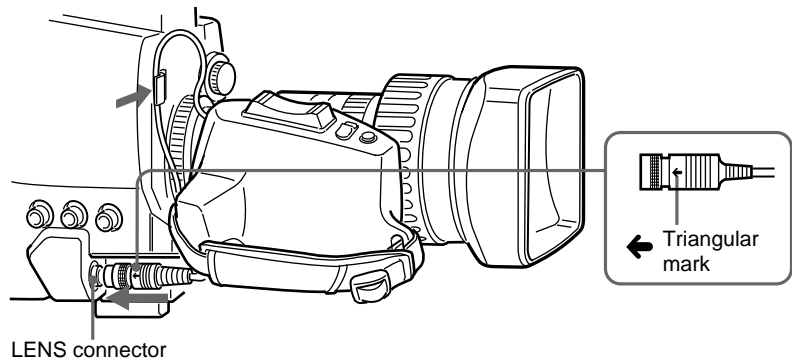

Fitting optional filters

Loosen the lens hood fixing screw to remove the lens hood, then attach the filter.

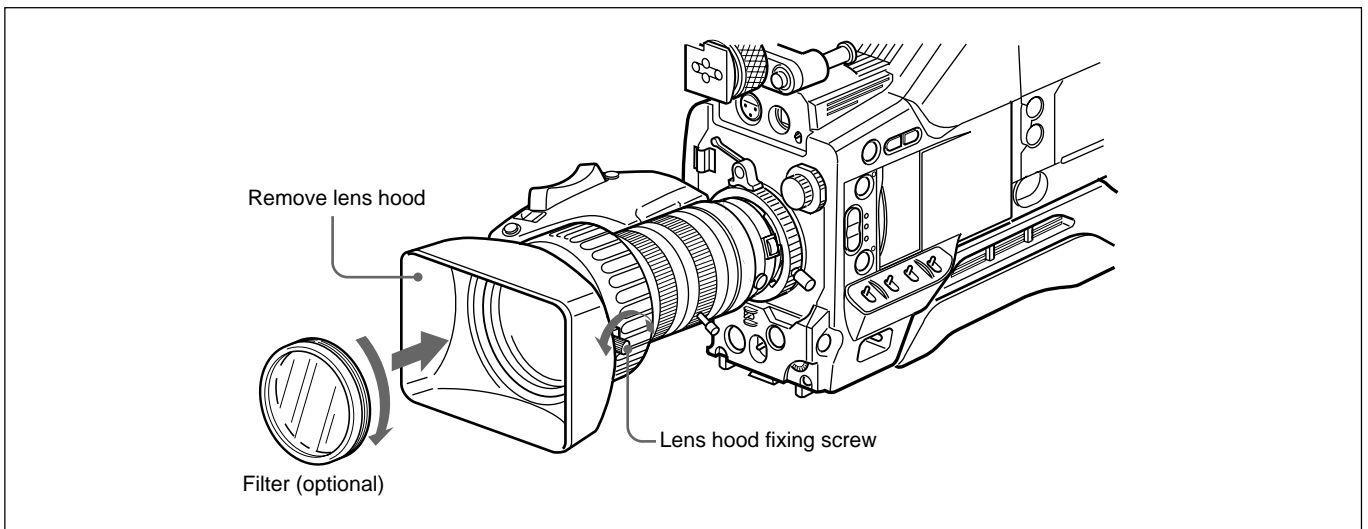

Using Accessories

Using the Viewfinder

Removing the Viewfinder

Remove any microphone from the viewfinder before beginning.

- 1 Pull the viewfinder connector out of the VF connector on the front of the camera head.

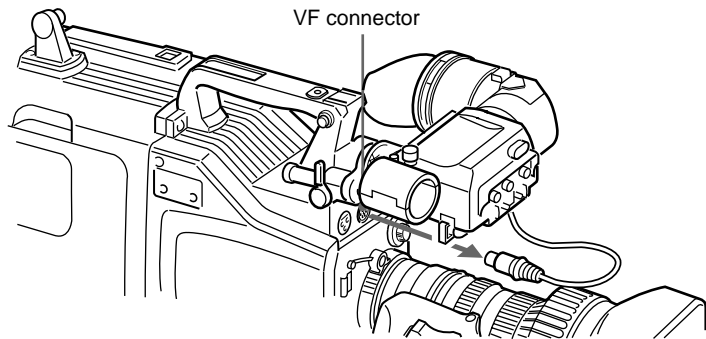

- 2 Loosen the viewfinder left-to-right position fixing ring, then pulling up the retaining catch, slide the viewfinder out.

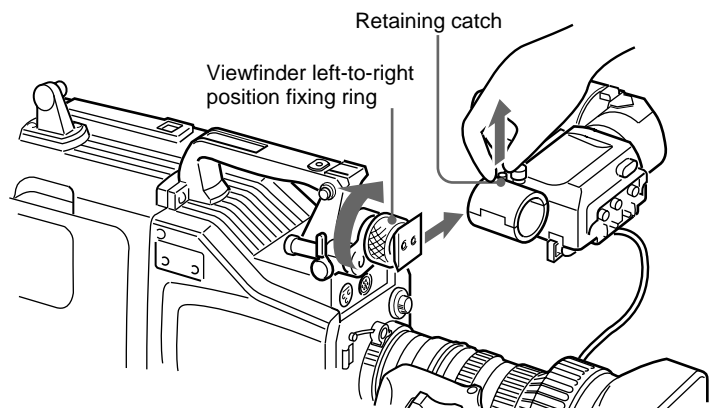

To fit the viewfinder

Reverse the removal procedure.

Adjusting the viewfinder position

To adjust the viewfinder left-to-right position, loosen the left-to-right fixing ring, and to adjust the front-to-back position loosen the front-to-back position locking catch.

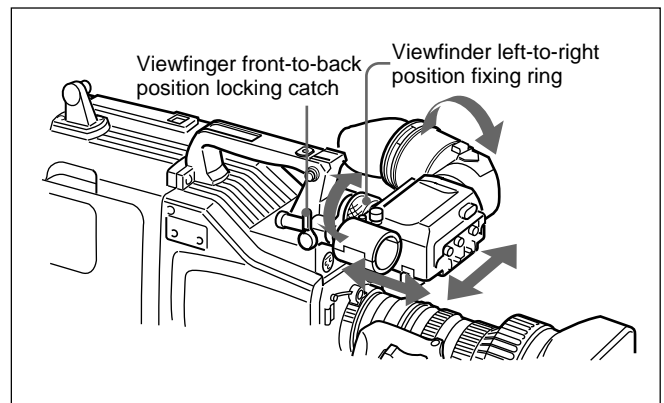

Left eye adaptor

By fitting a left eye adaptor, you can use the camera with your left eye to the viewfinder.

Note

You cannot stow the camera attached with a left eye adaptor in the LC-421 Carrying Case.

For details, consult your Sony dealer.

Using an Optional Microphone

To use a long microphone such as the optional ECM-670/672, fit an optional CAC-12 Microphone Holder to the camera, then mount the microphone in this holder.

Fitting the optional CAC-12 Microphone Holder

Remove the two retaining screws (M3 × 8) for the optional microphone holder, then use these screws to attach the CAC-12 Microphone Holder.

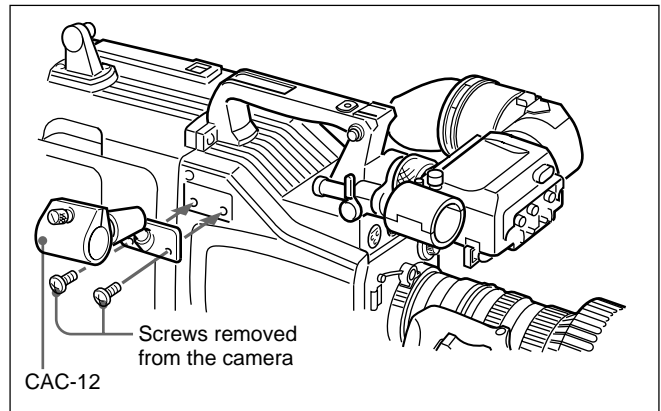

Fitting an optional microphone

Use the following procedure to attach an optional ECM-670 Microphone.

- 1 Loosen the screw of the CAC-12 Microphone Holder, then open the holder and replace the microphone adaptor with the one supplied with the ECM-670 Microphone.

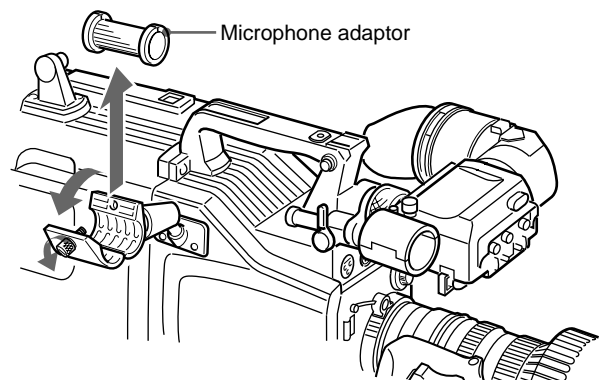

- 2 Insert the microphone in the microphone holder, close the holder, and tighten the screw. Connect the microphone cable to the MIC IN +48 V connector.

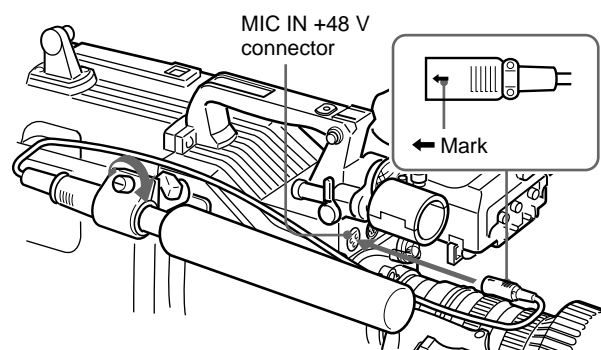

Using Accessories

Fitting optional microphones (operable with a 48 V supply) other than the ECM-670

Use the same fitting procedure as for the ECM-670, but note the following differences with respect to the microphone adaptor.

ECM-672: no microphone adaptor required.

Slender microphones (19 mm (3/4 inch) diameter): use the microphone adaptor supplied with the CAC-12.

Fitting to a Tripod

First fit the VCT-U14 Tripod Adaptor to the tripod, then mount the camera on the tripod adaptor.

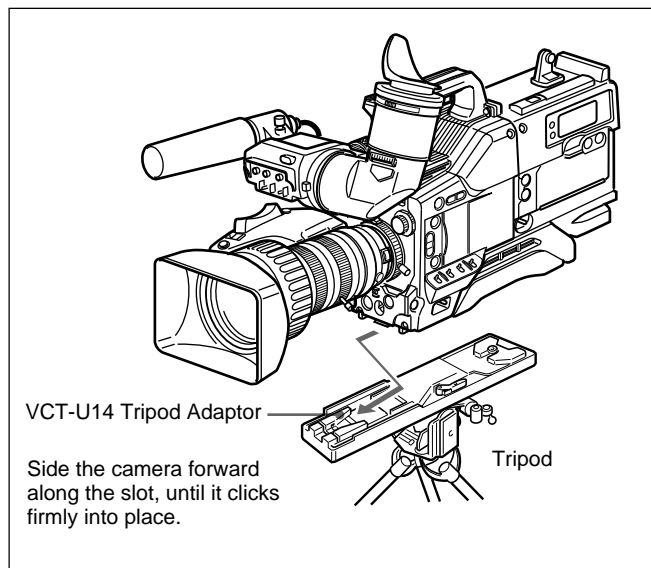

Removal

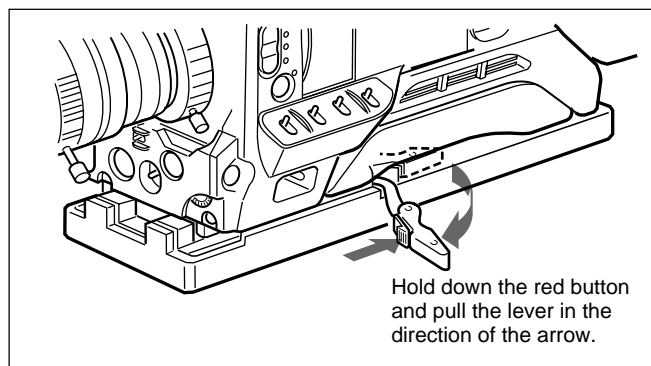

Note

After removing the camera, if the tripod adaptor pin has not returned to its original position, hold down the red button and move the lever in the direction of the arrow to return the pin to its original position. It is not possible to mount a camera with the pin left out.

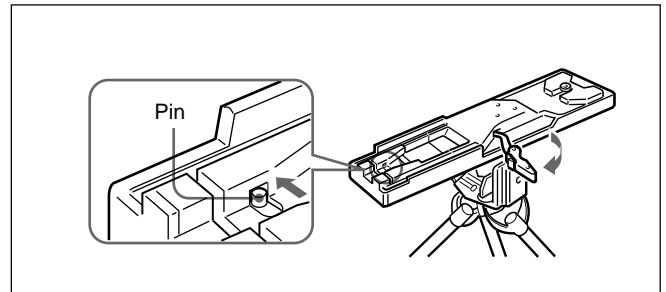

Using the Optional CAC-4 Chest Pad

When using the camera on your shoulder, attaching the optional CAC-4 Chest Pad reduces the load on your right hand supporting the zoom lens, and makes operation easier.

For details see the instructions provided with the CAC-4.

Using the Carrying Case

Stowing the camera

Align the camera with the base of the case, and slide the camera in forward.

Checking that the pin at the rear engages correctly, push forward until it locks into place.

Notes

- Bring the viewfinder into the horizontal position, slide it fully rearward and to the left, then fix before stowing.
- When an optional microphone (ECM-670/672, C-74, etc.) is attached, loosen the microphone fixing screws, move the microphone to the lowest position, and fix before stowing.

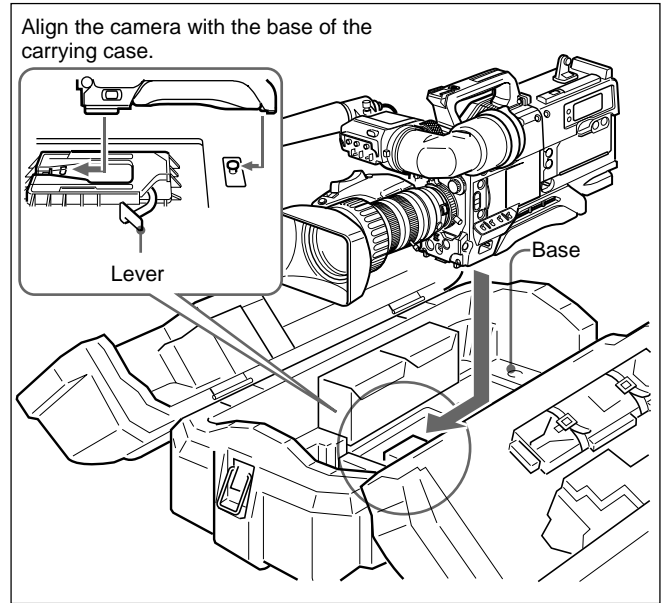

Example of fully-stowed carrying case

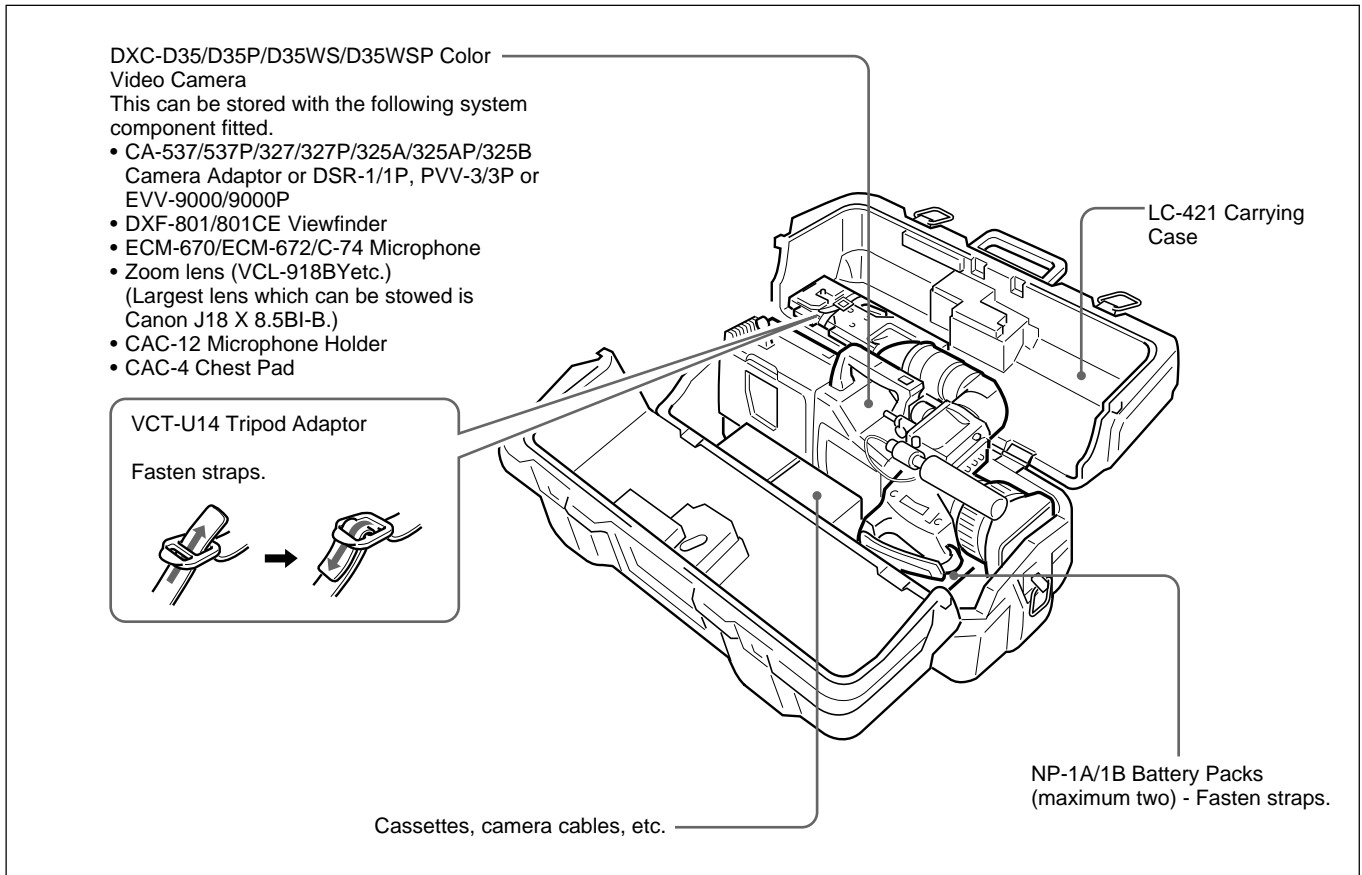

Connecting a Portable VTR

Using the optional CA-537/537P or CA-327/327P Camera Adaptor and a camera cable, you can connect a portable VTR. Set the VTR selector switch on the camera adaptor according to the VTR connected.

If using a VTR from another manufacturer, consult your Sony dealer.

Checks before making connections

Check first that the video camera, camera adaptor, VTR, and other devices are all powered off.

Making connections

Using a camera cable, connect the VTR/CCU/CMA connector on the camera adaptor to the camera input connector of the VTR.

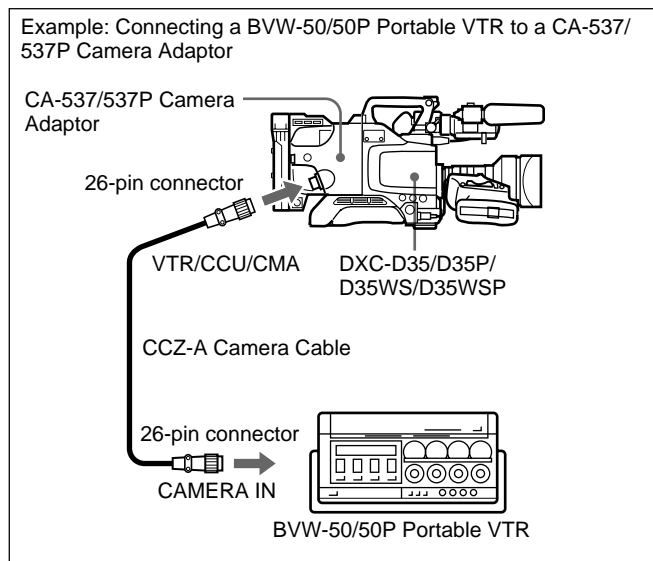

Camera cable

- Select a camera cable to fit the camera input connector on the VTR you are using.
- The maximum camera cable extent is 10 m (33 ft).

For details, consult your Sony dealer.

Video monitor

- If using an S-VHS VTR, using a video monitor with an S-video input connector and connecting it to the S-video connector of the VTR will allow you to monitor a clear picture, with no flecking.
- The output video signal from the VIDEO OUT connector of this unit is a composite video signal. Connect the VIDEO OUT connector of this unit to a composite video signal input connector of the monitor.

Setting the VTR selector switch on the camera adaptor

When using the camera with a CA-537/537P/327/327P Camera Adaptor, it is essential to correctly set the VTR selector switch on the camera adaptor according to the VTR connected. This switch determines the type of video signal output from the VTR/CCU/CMA connector and the audio output signal level.

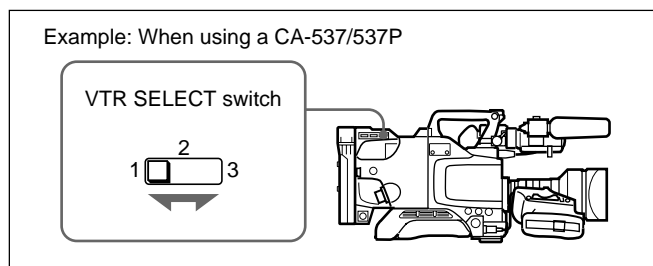

VTR selector settings on the CA-537/537P

Connected VTR	VTR selector switch setting	Video output signal	Audio output signal level
Sony broadcast and professional VTRs: BVU-150/150P, VO-6800/6800PS ^{a)} , BVW-50/50P and BVV-5/5PS ^{b)}	1	Composite (BVU-150/150P and VO-6800/6800PS) or component (BVW-50/50P and BVV-5/5PS)	-60 dB
Sony professional VTRs: VO-8800/8800P and EVV-9000/9000P	3	Y/C	-60 dB
Panasonic AG-6400 VHS VTR	2	Composite	-20 dB
Panasonic AG-7400 S-VHS VTR ^{c)} and JVC BR-S405 S-VHS VTR	3	Y/C	-20 dB

- Set the audio input level on the VO-6800/6800PS to -60 dB.
- When the BVV-5/5PS is used as a portable VTR, a VA-5/5P VTR Composite/Component Adaptor is required.
- Set the input selector switch on the AG-7400 to Y/C.

VTR selector settings on the CA-327/327P

Connected VTR	VTR selector switch setting	Video output signal	Audio output signal level
Sony broadcast and professional VTRs: BVU-150/150P and VO-6800/6800PS ^{a)}	1	Composite	-60 dB
Sony professional VTRs: VO-8800/8800P and EVV-9000/9000P	3	Y/C	-60 dB
Panasonic AG-6400 VHS VTR	2	Composite	-20 dB
Panasonic AG-7400 S-VHS VTR ^{b)}	4	Y/C	-20 dB

- Set the audio input level on the VO-6800/6800PS to -60 dB.
- Set the input selector switch on the AG-7400 to Y/C.

Connecting a Number of Cameras (Using a Camera Control Unit)

When using a number of cameras in the studio, it may be necessary to use a CCU-M5/M5P/M7/M7P Camera Control Unit to provide video and color sync between cameras, and special effects and other devices to allow switching, wipes and so forth.

In the studio it may also be convenient to use a DXF-41/51 Viewfinder.

The figure in the next page shows an example studio configuration.

For details, consult your Sony dealer.

Notes

- When using a camera control unit, put the camera head into the EZ mode off state beforehand (*see page 14*). (Otherwise, it is impossible to access the advanced menu.)
- With the DXC-D35/D35P/D35WSL/D35WSPL, color matrix switching on the CCU-M5/M5P is invalid.
- When the DL in advanced menu page 2 is set to ON (*see page 64*) and the OUTPUT/DL/DCC+ switch is set to DL, knee adjustment does not function on the CCU-M7/M7P.

Connections

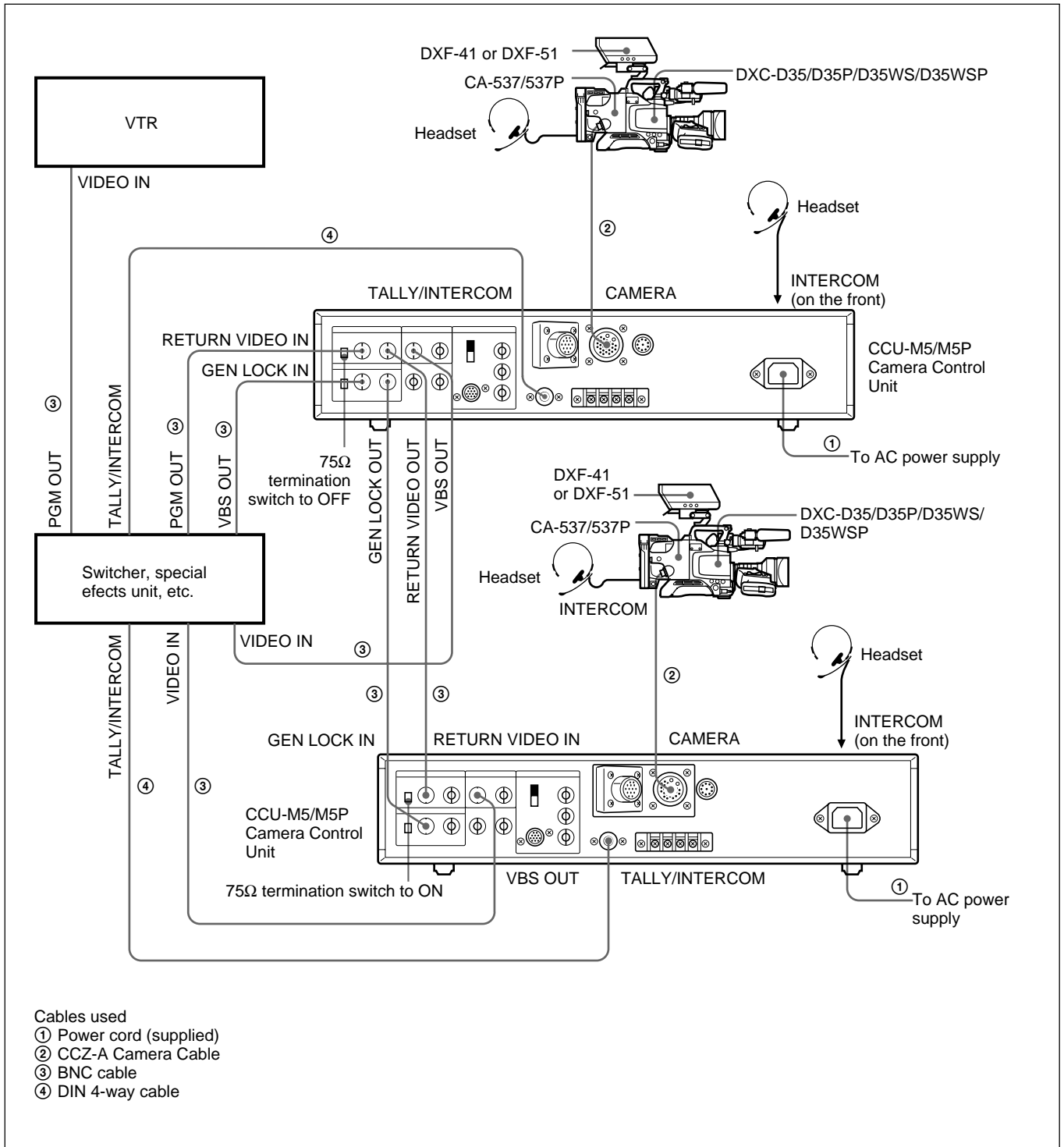

Connecting a Number of Cameras (Without Using a Camera Control Unit)

When using two or more synchronized cameras without a camera control unit, connect an external sync signal to the GEN LOCK IN connector on the camera adaptor (CA-537/537P etc.), supplying a VBS or BS

signal. The camera will then operate synchronized to this signal.

You can adjust the synchronization using the basic menus. (See page 59.)

Example 1: Camera 2 synchronized to the signal from camera 1

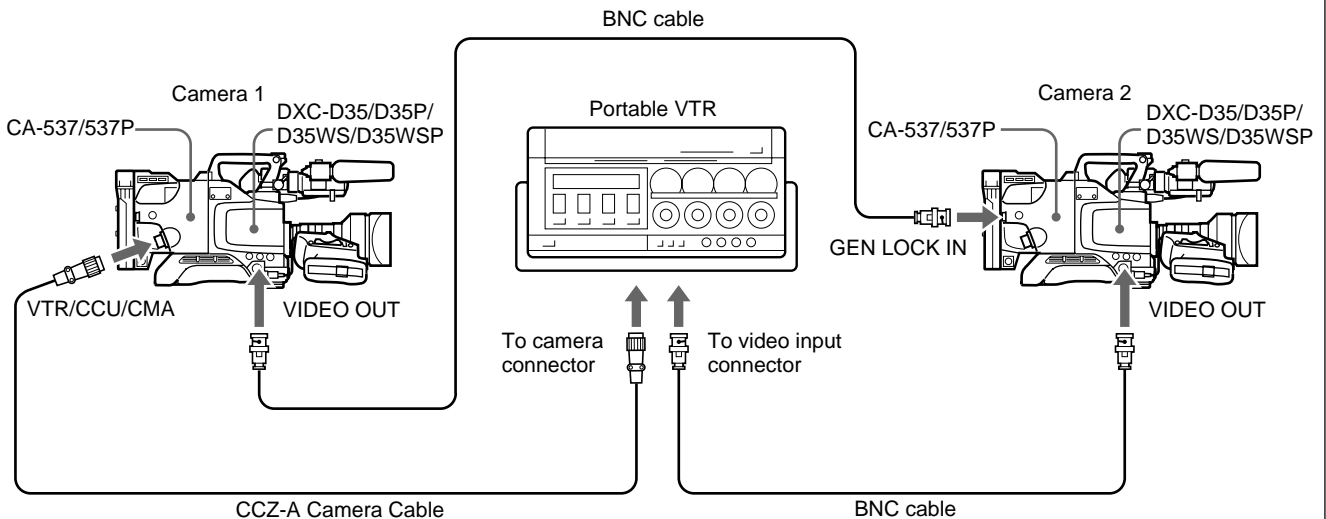

Example 2: Cameras 1 and 2 synchronized to the signal from a special effects unit or similar

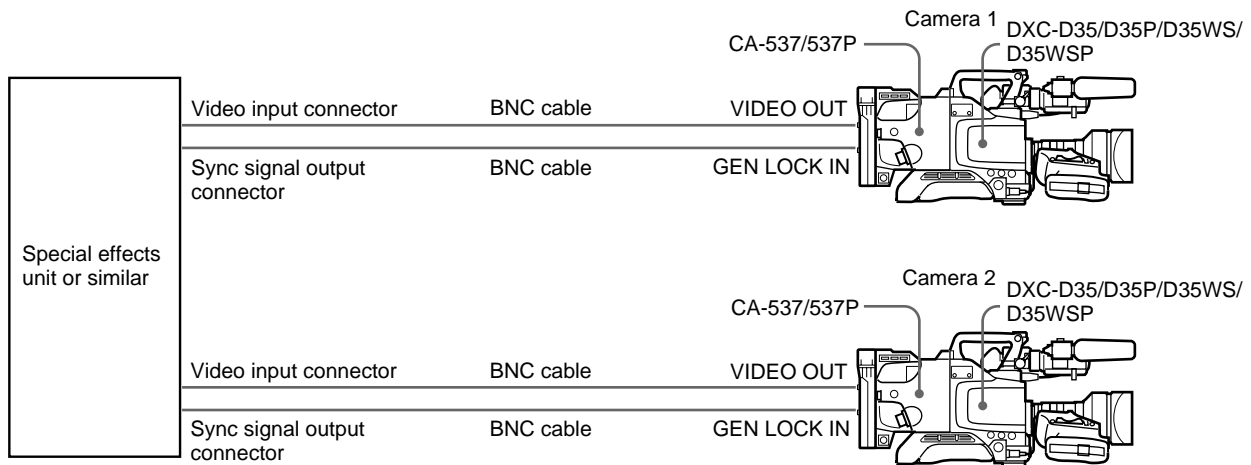

This unit operates on either a battery pack or an AC supply (using the optional CMA-8A/8ACE AC Adaptor).

For details of the power supplies which can be used, refer to the documentation supplied with the VTR connected to this unit or the camera adaptor.

Using an Anton Bauer Intelligent Battery System and Ultralight System

Fitting the special battery mount made by Anton Bauer Corporation to this unit allows you to use their Intelligent Battery System and Ultralight System.

For details, consult your Anton Bauer products supplier or Sony dealer.

Using Battery Packs

Always fully charge a battery pack before using it.

Notes

- Be careful that other metal objects do not come in contact with the metal parts of the battery pack, as this could cause a short.
- Do not leave the battery pack in the camera if it is not going to be used for a long time.
- If the battery pack is recharged after use while still hot, it may not be possible to obtain a full charge.

Battery pack operating times

The following table shows approximate continuous operating times, when operating the camera and 1.5-type viewfinder at normal temperatures, with a camera adaptor and the DSR-1/1P or PVV-3/3P connected.

Approximate operating times with a fully-charged battery pack

With DSR-1/1P

Battery pack	DXC-D35 /D35P	DXC-D35WSL/ D35WSPL
NP-1B ^{a)}	60 minutes	50 minutes
BP-90A ^{b)}	130 minutes	105 minutes
BP-L40	75 minutes	65 minutes
PB-L60A	150 minutes	130 minutes

With PVV-3/3P

Battery pack	DXC-D35 /D35P	DXC-D35WSL/ D35WSPL
NP-1B ^{a)}	60 minutes	50 minutes
BP-90A ^{b)}	130 minutes	105 minutes

a) Requires the special-purpose DC-L1 Battery Case.

b) Requires the special-purpose DC-500 Battery Case.

Battery low indications

When the voltage of the supply to the camera head lowers to or below 11.0 V, the battery voltage indication appears in the viewfinder. At this time, the BATT indicator in the viewfinder flashes when operating with the DSR-1/1P or PVV-3/3P.

If you continue using the camera head, the BATT indicator lights up.

When the battery pack is low, replace it with a fully-charged battery pack.

Battery pack charging

Before using a battery pack, charge it as shown in the following table.

Battery pack	Battery charger
NP-1B	BC-1WD/1WDCE, BC-410/410CE
BP-90A	BC-410/410CE
BP-L40	BC-L50/L100/L100CE
PB-L60A	BC-L50/L100/L100CE

For details of battery charger operation, refer to the instructions provided with the battery charger to be used.

Notes

- A warm battery pack may not be able to be fully recharged.
- Even when fully charged, battery packs gradually lose their charge naturally. Use the battery packs as soon as possible after recharging.
- To prolong the life of battery packs, store them in a cool place (about 20°C (68°F)), and charge in a place with an ambient temperature between 10°C and 30°C (50°F and 86°F).
- At low temperatures, the usable time of battery packs decreases. When the ambient temperature is 0°C (32°F), usable time decreases by about 10%. The usable time of battery packs increases if they are warmed to the room temperature (about 20°C (68°F)) before use at low temperatures.
- Compared to the BP-L40, the BP-L60A offers better performance at low temperature. The BP-L60A is recommended for use at low temperature.
- Carrying a spare battery pack is recommended.

The BP-L40/L60A is free from memory effect. There is no need to discharge it fully before recharging.

Camera Adaptor Power Supply

The camera adaptor automatically operates on power supplied to the VTR/CCU/CMA connector from the portable VTR, CCU-M5A/M5AP Camera Control Unit, CMA-8A/8ACE AC Adaptor or other connected device.

Note

Before use, check that the device connected to the VTR/CCU/CMA connector is able to provide the power required by the camera.

If it is not able to provide the necessary power, or when it is necessary to prolong the operating time, use the camera with a separate power supply.

Shooting

Basic Procedure for Shooting

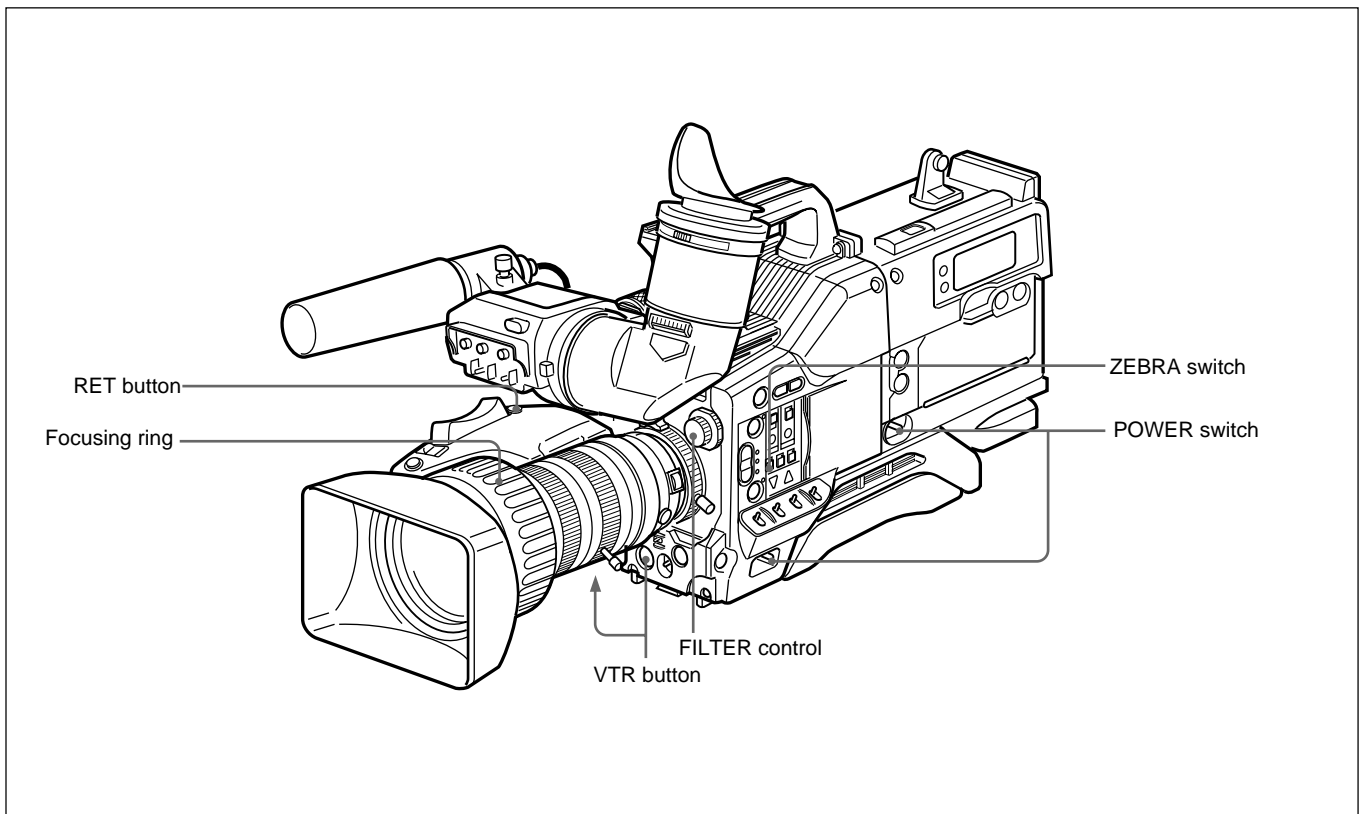

1 Attach the VTR or camera adaptor to the camera head, then turn each device's power on.

2 Set the FILTER control appropriately for the lighting conditions.

(continued)

Basic Procedure for Shooting

Filter setting	Lighting conditions
1 (3200K)	Studio halogen lighting (incandescent), sunrise and sunset.
2 (5600K + 1/8 ND)	Sunlight. This setting includes a 1/8 neutral density filter (reducing the exposure by the equivalent of three stops). Use it to prevent hunting ¹⁾ or to reduce the depth of field ²⁾ .
3 (5600K)	Cloudy or rainy outdoor shooting, and fluorescent lighting.
4 (5600K + 1/64ND)	Sunlight. This setting includes a 1/64 neutral density filter (reducing the exposure by the equivalent of six stops). Use it to prevent hunting ¹⁾ or to reduce the depth of field ²⁾ .

- 3** Check the switch settings on the camera head. (See pages 13 to 18.)
If there is not sufficient time to check the camera settings, you can use “easy mode” by setting the EZ MODE switch to the ON position. The camera is automatically adjusted to standard settings, and the iris and the white balance are adjusted automatically. (See page 68.)
- 4** Check the settings in the basic menu (page 58) and advanced menu (page 64).
- 5** Check the lens settings (pages 30 and 31) and flange focal length adjustment (page 89).
- 6** Adjust the eyepiece focus, and the contrast and brightness of the viewfinder image (page 88).
- 7** Check the sound system settings.
 - Microphone connections
 - Settings on the VTR (refer to the VTR instructions)
- 8** If required, switch on the center marker and/or safety zone (basic menu page 5 and advanced menu page 4) and zebra pattern (ZEBRA switch) in the viewfinder image.
- 9** Adjust the white balance (page 79) and black balance (page 83).

10 Turn the focusing ring so that the subject is sharply in focus. It may be convenient to use the EZ FOCUS button for the “easy focus” function (see page 14).

11 Set up the VTR according to your shooting objectives, then start recording.

If a camera control unit is not connected: Press the VTR button on the camera head or on the lens.

If a camera control unit is connected: Press the VTR’s record button to begin recording.

For details of VTR setup and operations, see your VTR’s operating instructions.

- During recording, the REC/TALLY indicator(s) in the viewfinder light(s), and “REC” appears on the viewfinder screen.
- Depending on the setting of the REC TIME switch (See page 15), you can display the total recording time or the length of the camera cut on the viewfinder screen.
- When recording on the DSR-1/1P, you can use the AUDIO LEVEL knob on the front of the camera head to manually adjust the channel 1 audio level. To do this, you must first set up the DSR-1/1P to enable manual adjustment of the audio recording level.

For details of this operation, see the operating instructions for the DSR-1/1P.

12 To pause recording, press the VTR button again.

1) **Hunting:** This occurs if the automatic iris function is not able to reach a stable state, and as a result the image brightness keeps changing, alternately lighter and darker.

2) **Depth of field:** This is the range over which the subject is sharply in focus.

Reviewing the recording

It is possible to review the last few seconds of the recording on the tape (recording review).

Press the VTR button to pause recording, then press the RET button on the lens.

Depending on how long the button is pressed, the tape is automatically rewound over the last two to ten seconds from the paused position, and then this part is played back in the viewfinder. If the RET button is kept pressing, about ten seconds of the recording review is possible.

The VTR then returns to the paused state.

Note

This function may not be provided by some VTRs. Refer to the instructions for the VTR.

Using the DynaLatitude Function

This function detects the bright and dark parts of the subject and automatically adjusts for the appropriate contrast. The DynaLatitude function enables fine-grained contrast adjustment according to the luminance level of each pixel. It is effective when shooting scenes with mixed light and dark parts.

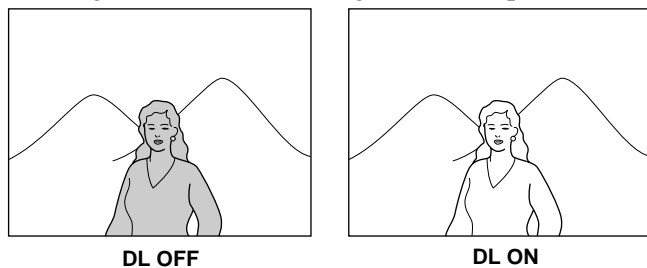

However, the brightness of the subject on the screen may change if the subject moves during shooting. Also, for some subjects, there may be increased noise in dark sections of the picture.

For information on turning this function on and off, see page 64. For information on setting effect levels, see page 59.

Shooting with the DSR-1/1P

The DXC-D35/D35P/D35WS/D35WSP docks with the DSR-1/1P to configure a DVCAM Camcorder. The following describes how to shoot using a DVCAM camcorder.

Using the ClipLink Function

The ClipLink function can be used at all stages from shooting to editing. This function makes editing operations more efficient by automatically recording index pictures (Mark IN point images) that provide a searchable index of recorded scenes, along with other data such as time code and scene numbers.

For concept of the ClipLink function, see the section “What Is ClipLink” (page 102).

- 1 Dock the DSR-1/1P to the camera head and turn on the power, then perform steps **2** to **10** from “Basic Procedure for Shooting” (page 43).
- 2 Insert a cassette into the DSR-1/1P and set ClipLink mode to ON by menu setting.

For details of this operation, see the operating instructions for the DSR-1/1P.

The following display appears on the viewfinder screen.

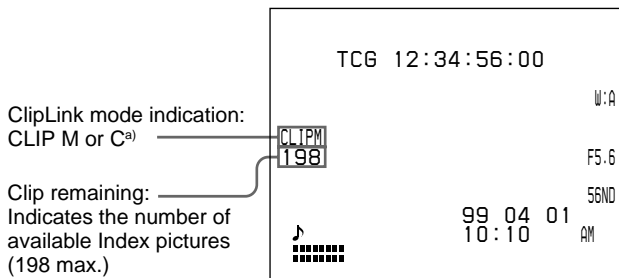

- a) For details, see “Basic menu page 6” (page 60).

To record the cassette name/number

Access basic menu page 6 to specify a name or number for the inserted cassette.

For details, see “Basic menu page 6” (page 60).

- 3 Press the VTR button on the camera head or the lens.

The DSR-1/1P starts recording, and the REC/TALLY indicator lights in the viewfinder. Meanwhile, the time code at the recording start point (Rec IN) is recorded (HH:MM:SS) in the DSR-1/1P’s internal memory.

- 4 When a shooting of the scene completes, press the VTR button on the camera head or the lens.

This pauses recording.

To continue recording the next scene, repeat steps **3** and **4**. The scene number will be automatically incremented.

To set/clear NG (No Good)

If you press the NG button before you start shooting the next scene, the previous scene will be designated as “NG” (the “NG” display appears in the viewfinder).

Once NG has been set, you can cancel it by pressing the NG button again before you start shooting the next scene (the “NG” display in the viewfinder disappears, which means that the previous scene has been re-designated as “OK”). Each time you press the NG button before starting shooting the next scene, the status of the previous scene toggles between “NG” and “OK”. It is always the last selected status that will take effect and be stored in the cassette memory.

- 5 To finish recording, press the STOP button on the DSR-1/1P.

This stops recording.

Note

When using the ClipLink function while shooting, if you continue shooting after stopping or if you change the tape’s recording position, your subsequent shots may overwrite and erase the previously recorded ClipLink log data (time codes, scene number, etc.) or index pictures.

To avoid this problem, press the DSR-1/1P’s ClipLink CONTINUE button before restart of shooting.

For details, see the operating instructions for the DSR-1/1P.

Setting Mark IN/OUT points as you shoot

Instead of continuing shots from scene to scene, you can specify Mark IN and Mark OUT points as you shoot and set scene numbers (ranging from 001 to 198).

- 1** Perform steps **1** and **2** from “Using the ClipLink Function” (page 46).
- 2** Access basic menu page 6 and perform the following operations.
 - 1)** Set MARK/CUE to MARK.
The ClipLink mode indication “CLIP M” appears on the viewfinder screen.
 - 2)** Set the cassette name or number if necessary.

For details of menu operations, see “Basic Menu Operations” (page 58).

- 3** Press the VTR button on the camera head or the lens.

The DSR-1/IP starts recording, and the REC/TALLY indicator(s) light(s) in the viewfinder.

- 4** Press the TAKE button when you find a shot where you would like to set a Mark IN point.

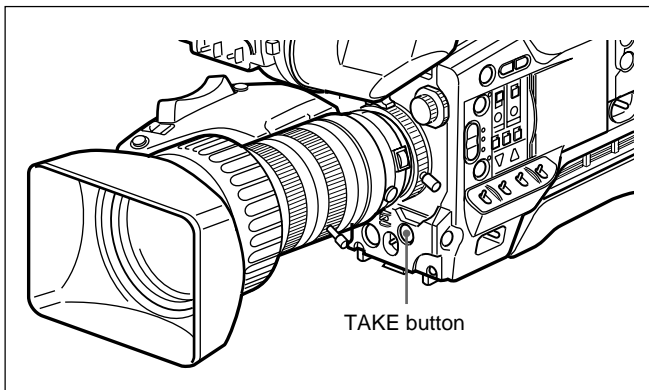

The TAKE/TALLY indicator (orange) lights in the viewfinder and “TAKE” appears on the screen.

- 5** Press the TAKE button when you find a shot where you would like to set a Mark OUT point.

The TAKE/TALLY indicator (orange) goes out in the viewfinder and the “TAKE” disappears from the screen.

At this time, the time code (HH:MM:SS) at the Mark IN/OUT point for scene 001 is recorded to the DSR-1/IP’s internal memory, and then recorded to the cassette memory.

To set/clear NG

If you press the NG button before you set the next Mark IN point, the previous scene will be designated as “NG” (the “NG” display appears in the viewfinder).

Once NG has been set, you can cancel it by pressing the NG button again before you set the next Mark IN point (the “NG” display in the viewfinder disappears).

- 6** Repeat steps **4** and **5** as needed to record (to cassette memory) time codes at Mark IN/OUT points, scene numbers, and NG designations to the cassette memory.

The scene number is automatically incremented each time you specify a Mark OUT point.

- 7** To finish shooting, press the VTR button on the camera head or the lens, then press the DSR-1/IP’s STOP button.

This stops the recording operation. The index pictures of each Mark IN point are recorded onto the tape.

Setting cue points as you shoot

You can make edit search operations easier by specifying cue points to highlight scenes.

- 1** Perform steps **1** and **2** in “Using the ClipLink Function” (page 46).
- 2** Access basic menu page 6 and perform the following operations.
 - 1)** Set MARK/CUE to CUE.
The ClipLink mode indication “CLIP C” appears on the viewfinder screen.
 - 2)** Set the cassette name or number if necessary.

For details of menu operations, see “Basic Menu Operations” (page 58).

- 3** Press the VTR button on the camera head or the lens.

The DSR-1/1P starts recording, and the REC/TALLY indicator lights in the viewfinder. Meanwhile, the recording start point (Rec IN) is recorded in the DSR-1/1P’s internal memory.

- 4** Press the TAKE button when you find a shot where you would like to set a cue point.

The “CUE” indication appears (for about 1 second) on the viewfinder screen. At this point, the time code (HH:MM:SS:frame) at the cue point is recorded into the cassette memory.

- 5** Repeat step **4** to specify more cue points.
- 6** To finish shooting, press the VTR button on the camera head or the lens, then press the DSR-1/1P’s STOP button.

This stops recording operation. Time codes (HH:MM:SS) and scene number (scene 001) are recorded to the cassette memory and the index picture of the Rec IN point is recorded onto the tape.

Using the Edit Search Function While Back Space Editing

While the DSR-1/1P is in recording pause mode, press and hold the EDIT SEARCH buttons to activate the search playback function for as long as you hold down the button. You can use the edit search function to find the desired tape location after a recording stop during back space editing or when continuing to record from any other location on the tape.

- 1** Dock the DSR-1/1P to the camera head and turn on the power, then insert a cassette into the DSR-1/1P.
- 2** Perform steps **2** to **12** in “Basic Procedure for Shooting” (page 43).
- 3** Press and hold either of the EDIT SEARCH buttons (REV or FWD)

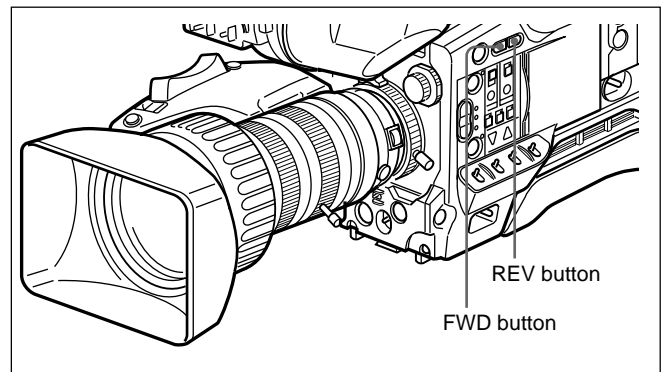

The tape is moved in reverse or forward search mode for as long as you hold down the REV or FWD button, and the image is shown in the viewfinder.

To change the playback speed

Press the REV or FWD button down firmly into the inner position to make the tape move at the faster speed. Press the button down lightly to make the tape move at the slower speed.

Note

Do not shut off the camera head’s power while using the edit search function. The DSR-1/1P may not be able to find the continue point.

- 4** Release the REV or FWD button when you find the tape location where you wish to continue shooting.

The DSR-1/IP enters recording pause mode.

- 5** Press the VTR button on the camera head or the lens.

The DSR-1/IP starts recording.

Using the Freeze Mix Function

The freeze mix function superimposes a freeze-frame image of a previously recorded shot on the shooting image displayed on the viewfinder screen. You can use this function to easily frame a subject within the same framework from a previous shot.

Note

When the camera head is in EZ mode, the freeze mix function is disabled. Release the EZ mode beforehand. (See page 14.)

- 1** Dock the DSR-1/IP to the camera head and connect a color monitor to the MONITOR OUT connector.
- 2** Perform steps **2** to **10** from “Basic Procedure for Shooting” (page 43).
- 3** Play back the tape on which the image to be used for framework alignment has been recorded.

For playback operation, refer to the operating instructions for the DSR-1/IP.

- 4** Press the MENU/STATUS switch down.

The following indication appears on the screen.

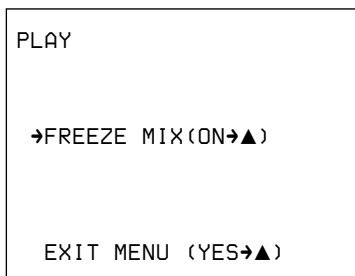

- 5** Press the UP/ON button when you see the image you want to freeze.

The frozen playback image is displayed, mixed with the shooting image, in monochrome. The indication “FREEZE MIX ON” appears on the screen.

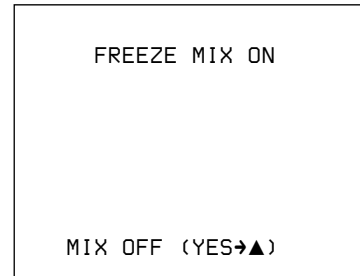

To release the freeze mix mode, press the UP/ON button again.

To change the freeze-frame image

Press the DSR-1/IP’s PLAY button.

This returns to the screen shown in step **3** above, and color playback mode begins.

Use the DSR-1/IP’s tape transport buttons to find the desired image and then perform steps **4** and **5** again.

- 6** Once you have framed your subject, press the UP/ON button to cancel the freeze function.
- 7** Find the recording start point or insert a new cassette for recording, then begin recording.

Note

If you use the DSR-1/IP’s tape transport buttons during back space editing, the back space editing mode will be stopped. When you were using the ClipLink function when shooting, If you simply restart the recording you will lose any ClipLink data that was recorded. To avoid this, press the DSR-1/IP’s ClipLink CONTINUE button before restarting recording.

For details, see the operating instructions for the DSR-1/IP.

Viewfinder Screen Indications and Menus

Viewfinder Screen Indications

There are four types of indication screen which appear in the viewfinder, as follows.

- **Normal indications**

These show the operating state of the camera and connected VTR. (See page 54.)

- **Status indications**

Pressing the MENU/STATUS switch up while the normal indications are present calls a display of current settings. (See page 57.)

- **Basic menu**

These provide settings for the lens iris, shutter speed and so forth, and also a titling screen. (See the section “Viewfinder Basic Menu” page 58.)

- **Advanced menu**

These provide settings for the center marker, zebra pattern, viewfinder screen indications, and so forth. (See the section “Viewfinder Advanced Menu” page 64.)

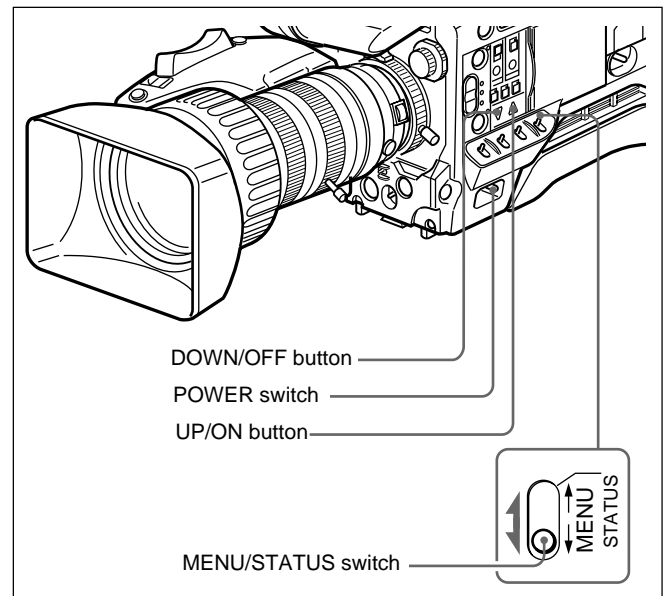

Changing the Viewfinder Display

Use the buttons and switches shown in the following figure to switch the viewfinder display among the normal indications, basic menu pages and advanced menu pages.

Displaying the normal indications and switching to the basic menu

To display the normal indications, move the POWER switch to the ON position.

To switch to and from the basic menu, use the MENU/STATUS switch.

Viewfinder Screen Indications

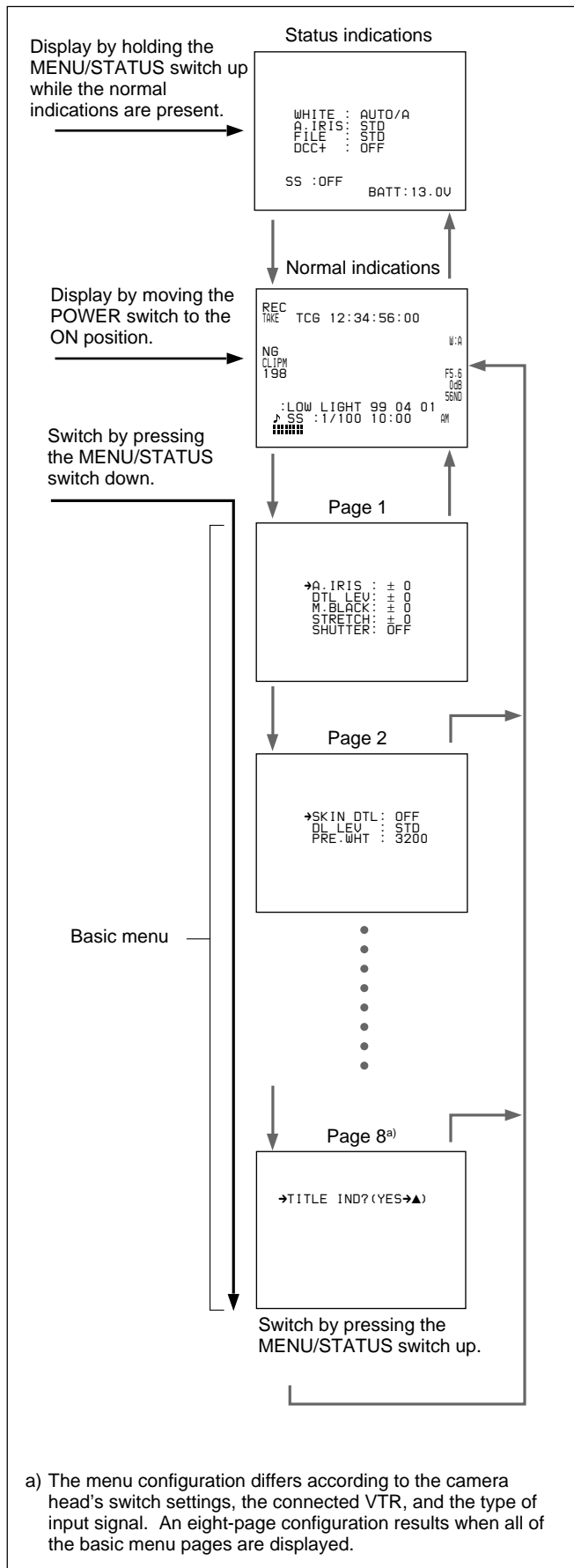

Displaying the advanced menu and switching to the normal indications

Use the following procedure to display the advanced menu.

- ① Move the POWER switch to the ON position while holding down the UP/ON button to display the advanced menu selection screen.
- ② **To display advanced menu page 2 immediately**, move the cursor to the menu number and then press the DOWN/OFF button.

To reinitialize all settings in the advanced menu to their factory defaults

- ① Align the cursor to ALL RESET and press the UP/ON button. (The indication changes to “ALL RESET SURE?”.)
- ② Press the UP/ON button again. (The indication changes to “ALL RESET OK” and reinitialization completes.)
To cancel the reinitialization, move the cursor instead of pressing the UP/ON button.

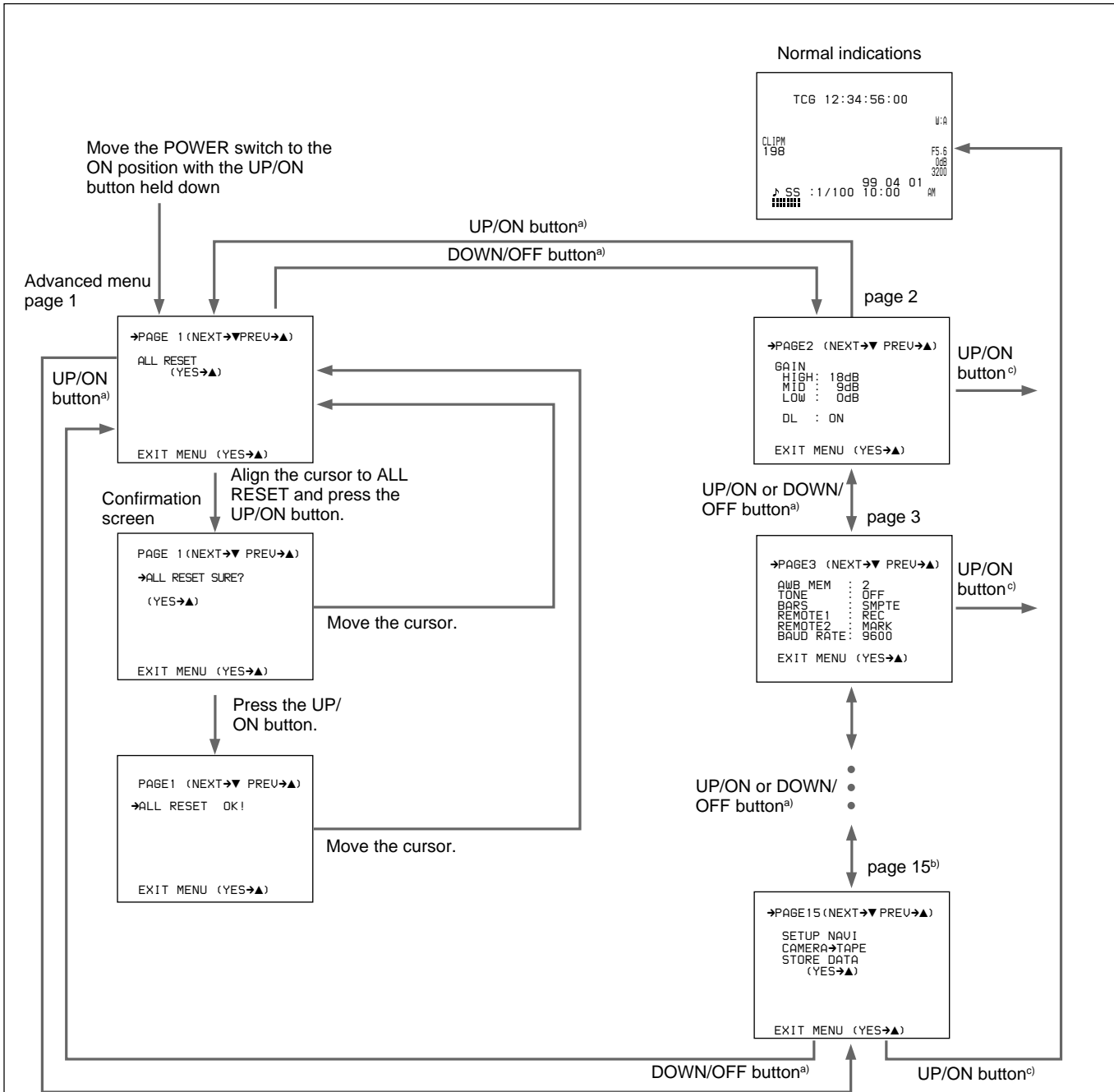

- a) Set the cursor to the page number and press the UP/ON or DOWN/OFF button.
- b) The menu configuration differs according the camera head's switch settings, the connected VTR, and the type of input signal. A 15-page configuration results when all of the advanced menu pages are displayed.

c) Set the cursor to EXIT MENU and press the UP/ON button.

Viewfinder Normal Indications

During normal operation, the following items can be indicated in the viewfinder.

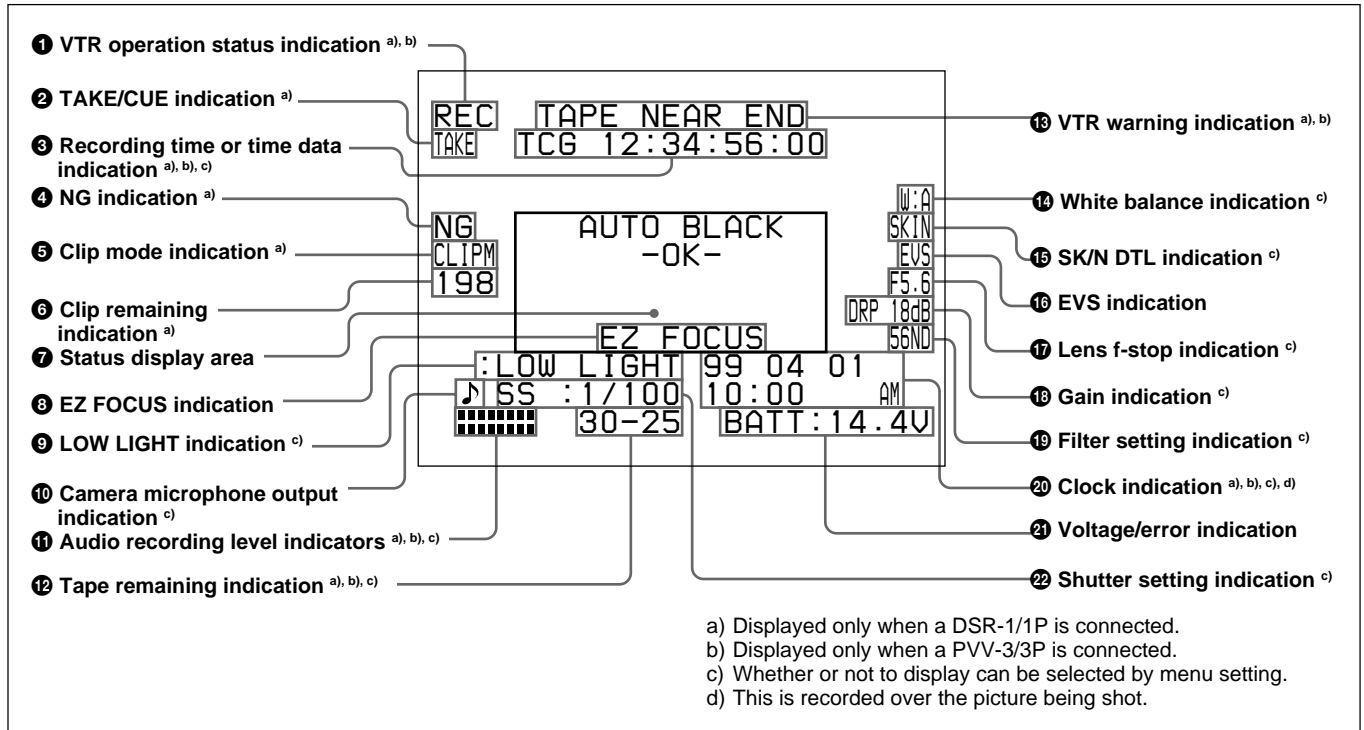

The significance of each of the indications shown in the figure is as follows.

1 VTR operation status indication

This indicates the VTR's current operation status (REC, PLAY, etc.).

2 TAKE/CUE indication

This displays a TAKE or CUE indicator when using the ClipLink function and recording with the DSR-1/1P.

TAKE: When recording in Mark mode, this indication appears when a Mark IN point is set and disappears when the next Mark OUT point is set.

CUE: When recording in Cue mode, this indication appears for about 1 second when a cue point is set.

3 Recording time or time data indication

This shows the following values.

- When the REC TIME switch on the camera is in the TTL position: The total recording time
- When the REC TIME switch on the camera is in the DUR position: The duration of the current recording cut

- With a VTR connected, when the REC TIME switch on the camera head is in the OFF position and the item TC IND in advanced menu page 6 is set to "ON": A time data value from the VTR depending on the DISPLAY switch settings on the VTR as shown in the following table

DISPLAY switch setting	Time data displayed
COUNTER	CNT: Tape transport time
TC	TCG: a time code from the time code generator TCR: a time code from the time code reader
U-BIT	UBG: a user bit value from the user bit generator

When using the DSR-1/1P, time data values appear during playback, fast forward, rewind, or recording review.

4 NG indication

An "NG" (No Good) indicator appears if you designate a recorded scene as "NG" when using the ClipLink function and recording with the DSR-1/1P.

5 Clip mode indication

A “CLIP M” or “CLIP C” indication appears when you use the ClipLink function and record using the DSR-1/1P.

CLIP M: Indicates shooting in Mark mode

CLIP C: Indicates shooting in Cue mode

6 Clip remaining indication

The number of available index pictures remaining is displayed when you use the ClipLink function with the DSR-1/1P.

7 Status display area

One of the following values or messages is displayed to indicate the camera head’s current status or its operation status.

- New values when changing camera head’s settings
- Messages indicating progress or results of adjustments
- The camera head’s current settings
- SetupLog data recorded to tape during shooting (*see page 78*)

Note

The status indication is not shown while the EZ FOCUS indication 8 appears.

8 EZ FOCUS indication

This appears when the EZ FOCUS button is pressed, enabling the “easy focus” function.

9 LOW LIGHT indication

This warning appears if the lighting level is inadequate.

10 Camera microphone output indication

This appears when there is an input from the camera microphone.

Note

This indication serves as a check on whether the camera microphone is operating correctly, but it does not provide confirmation that the VTR is recording sound. Check that the audio recording levels on the VTR are set correctly.

11 Audio recording level indicators

These show the recording levels of audio channels 1 and 2 on the VTR.

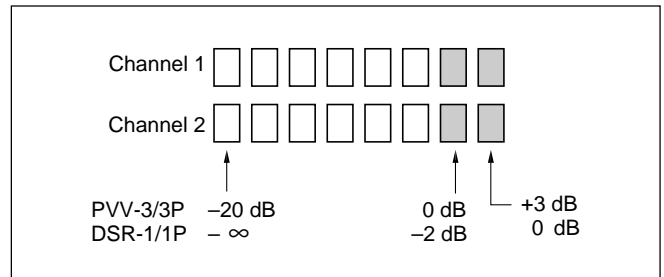

12 Tape remaining indication

This shows the tape remaining in the VTR as follows.

Indication	Tape remaining
F-30	At least 30 minutes
30-25	25 - 30 minutes
25-20	20 - 25 minutes
20-15	15 - 20 minutes
15-10	10 - 15 minutes
10-5	5 - 10 minutes
5-0	2 - 5 minutes
5-0 (flashing)	0 - 2 minutes

13 VTR warning indication

This shows warning indications about operation or status of the connected VTR.

When connecting the DSR-1/1P or PVV-3/3P

Indication	Meaning
NO TAPE	There is no tape loaded.
REC INHIBIT	The tape is in the recording inhibited state.
LOW BATT.	The battery is almost exhausted.
BATT. END	The battery is exhausted.
TAPE NEAR END	The tape is near the end.
TAPE END	The tape is at the end.
CHECK REMOTE (PVV-3/3P only)	A device other than a remote control unit (e.g. headphones) is connected to the REMOTE connector.
SERVO	The servo lock has been lost.
HUMID	There is condensation.
RF	The video heads are clogged, or there is some other fault in the recording system.
SLACK	The tape is not wound properly.
OXIDE TAPE (PVV-3/3P only)	An oxide tape has been loaded. (The tape is automatically ejected.)

Viewfinder Normal Indications

Only when connecting the DSR-1/1P

Indication	Meaning
50P CONNECT	Connection with the PRO 50-pin connector on the DSR-1/1P. (Freeze mix function is disabled.)
MP TAPE	An incorrect type of cassette has been loaded. (The cassette is automatically ejected and the indication disappears in about two seconds.)
CLIP DATA ERR	Abnormality of the cassette memory data.
AUDIO 48kHz? (4 flashes/s)	At back space editing, audio recording mode has changed from 32 kHz mode (4-channel mode) to 48 kHz mode (2-channel mode).
AUDIO 32kHz? (4 flashes/s)	At back space editing, audio recording mode has changed from 48 kHz mode (2-channel mode) to 32 kHz mode (4-channel mode).
ERROR:91-13F	Failure in loading or saving the cassette memory data. When other error indication appears, refer to the operating instructions for the DSR-1/1P.
CLIP CONT?	Asking whether you will continue shooting in ClipLink mode or not when the cassette contains ClipLink data. (The indication disappears when you press the ClipLink CONTINUE button on the DSR-1/1P or start the next shooting without pressing it.)
CLIP NEAR END	At back space editing in ClipLink mode, capacity for only 1 to 3 index pictures remains.
CLIP END	Impossible to record any more clip shots.

14 White balance indication

The following indications appear.

Indication	Meaning
EZ	Operating in EZ mode (The ATW function is selected.)
ATW	The ATW function is selected. (The ATW button was pressed and the indicator is lit.)
W:A	White balance memory A is selected.
W:B	White balance memory B is selected.
W:P	Preset white balance is selected.
W:M	Manual adjustment is performed remotely.

15 SKIN DTL indication

This appears when the skin detail function is activated (The SKIN DTL switch is set ON.)

16 EVS indication

This appears when the EVS (Enhanced Vertical definition System) function is enabled. (See page 84.)

17 Lens f-stop indication

This shows the f-stop of the lens.

Note

Depending on the lens being used, this indication may differ slightly from the actual f-stop on the lens.

18 Gain indication

This shows the gain value, and the settings of the HYPER GAIN switch and the DPR (Dual Pixel Readout) function (see page 64) as shown in the following table.

Example indication	Meaning
18dB	Gain setting is 18 dB.
DPR 18dB	The DPR function is enabled. In this case the DPR function approximately doubles the gain (an increase of 6 dB) over the current gain setting (in this case 18 dB).
HYPER	The HYPER GAIN switch is in the ON position. In this case the hyper gain function increases the gain by a factor of about 60 or 120 with respect to 0 dB regardless of the current gain setting (that is, increased to 36 or 42 dB).

19 Filter setting indication

This shows the setting of the FILTER control.

Indication	Filter setting
3200	1 (3200K)
56ND	2 (5600K + 1/8ND)
5600	3 (5600K)
56ND	4 (5600K + 1/64ND)

20 Clock indication

The clock indication is shown in one of the following ways (according to the CLOCK IND setting of CAM, BARS, or OFF in advanced menu page 8).

CAM: Always displayed.

BARS: Displayed whenever color bars are displayed.

OFF: Not displayed.

If the clock indication is displayed during recording, it is recorded onto the image.

21 Voltage/error indication

The current voltage is displayed whenever the camera head's power supply voltage dips below 11.0 V DC. However, you can also display the current voltage at any time by pressing and holding the MENU/STATUS switch in the upward position (the display is shown for as long as you hold the switch upward).

An error message is displayed when an abnormality has been detected by the auto diagnostic function (page 62).

If an error message appears, contact your Sony dealer.

If using a VTR and an Anton Bauer Intelligent Battery System

The remaining battery capacity is shown as a percentage.

22 Shutter setting indication

When the SHUTTER switch has been set to ON, the shutter speed, CLS frequency or EVS set in basic menu page 1 is displayed here.

Status Indications

If you set the MENU/STATUS switch to STATUS while a menu is being displayed, the camera head's current setting status will be shown in this display area.

```
WHITE : A 3200K
A.IRIS : STD
FILE   : STD
DCC+   : OFFa)

SS     : OFF
BATT  : 13.0V
```

a) When both the DCC+ and DynaLatitude functions are set to OFF

Display	Description
WHITE	White balance adjustment method selection (PRE/A/B) and color temperature during auto white balance adjustment
A.IRIS	Iris adjustment method selection (STD/SPOT L/BACK L)
FILE	STD (when not using the setup files), or a selected file name (when using the setup files) (see page 71).
DCC+ or DL	For DCC+ indication: ON with the OUTPUT/DL/DCC+ switch set to CAM/DCC+ (DCC+ON), and OFF with the switch set to CAM/DL and DL in advanced menu page 2 (page 64) set to OFF (both DCC+ and DynaLatitude OFF). For DL indication: When setting the OUTPUT/DL/DCC+ switch to DL and DL in advanced menu page 2 to OFF (DynaLatitude OFF), LOW, STD or HIGH is displayed according to DL LEV setting in basic menu page 2 (page 59).

Viewfinder Basic Menu

To display the basic menu pages, press the MENU/STATUS switch downward while the normal indications are being shown in the viewfinder. The basic menu configuration can include up to eight pages (the configuration depends on the switch settings and the type of connected VTR).

Basic Menu Operations

The common operations on all basic menu pages are described below.

To change the page or item

The cursor is moved downward each time you press the MENU/STATUS switch down. Once the cursor has reached the last item on a page, press down the MENU/STATUS switch to go to the next page. When the last page is being displayed, pressing down the MENU/STATUS switch returns the display to the normal indications.

The cursor is moved upward each time you press up the MENU/STATUS switch. Once the cursor has reached the first item on a page, pressing up the MENU/STATUS switch returns the display to the normal indications.

To change settings

After using the MENU/STATUS switch to move the cursor to the item on which you will change the setting, press either the UP/ON button or the DOWN/OFF button to select the desired value.

To reset any item to its shipped settings, press the UP/ON button and the DOWN/OFF button at the same time.

Contents and Settings of Each Page

Each page's contents and settings are described below.

On the DXC-D35WSL/D35WSPL, when the MENU MODE is set to 2 in advanced menu page 9, a page for aspect ratio settings (16:9/4:3) is added before basic menu page 1.

Basic menu page 1

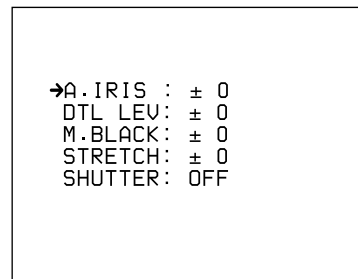

Item	Settings
A. IRIS Sets a base value for auto adjustment of lens iris.	-1.0, -0.5, ±0 (normal value), +0.5, +1.0 Negative adjustment values set a narrower lens iris and positive values set a wider lens iris.
DTL LEV Sets the detail (edge) emphasis.	-99 to ±0 (normal value) to +99 Negative adjustment values soften the image's edges and positive values sharpen them.
M. BLACK Sets the master pedestal level.	-99 to ±0 (normal value) to +99 Negative adjustment values make dark areas of the picture darker and increase the contrast. Positive adjustment values make dark areas of the picture lighter and reduce the contrast.
STRETCH Sets black stretch/compress value.	-16 to ±0 (normal value) to +15 This function adjusts the intensity of dark areas of the screen. Negative values make these areas darker (black compress) and positive values make these areas brighter (black stretch).
SHUTTER Sets shutter speed or CLS/EVS setting (see page 84).	DXC-D35/D35WSL: 1/100 (normal value), 1/250, 1/500, 1/1000, 1/2000, EVS, CLS (60.4 Hz to 200.3 Hz) DXC-D35P/D35WSPL: 1/60 (normal value), 1/250, 1/500, 1/1000, 1/2000, EVS, CLS (50.3 Hz to 201.4 Hz) This selects either the shutter speed or the scan frequency or EVS for the clear scan function.

Basic menu page 2

```

→SKIN DTL: 0.0
DL LEV : STD
PRE.WHT : 3200

```

Item	Settings
SKIN DTL Sets the amount of skin detail correction.	0.0 (normal value) to 1.0 Smaller values set a softer skin detail.
DL LEV Sets the DynaLatitude level.	LOW, STD (normal value), HIGH Set the amount of DynaLatitude effects as high level, standard level (STD), or low level.
PRE.WHT Sets the color temperature of the preset white balance.	When the FILTER control is set to 1 (3200K): 2200 to 3200 (normal value) to 4300 When the FILTER control is set to 2 (5600K + 1/8 ND), 3 (5600K) or 4 (5600K + 1/64 ND): 4600 to 5600 (normal value) to 12000

Basic menu page 3

This is displayed when the SET UP switch has been set to FILE.

```

FILE: *FL
→SELECT FILE
HISAT
CHG FILE
(YES→▲)

```

For details of this operation, see “Setup Files” (page 71).

Basic menu page 4

This menu is displayed only when an external sync signal is input to the camera adaptor or VTR connected to the camera head.

```

→SC PHASE: 000
H PHASE: 135

```

Item	Settings
SC PHASE Sub carrier phase adjustment for when camera is genlocked. ^{a)}	000 (normal value) to 999
H PHASE Horizontal phase adjustment for when camera is genlocked. ^{a)}	000 to 135 (normal value) to 199

a) This applies when using an external sync signal to synchronize operation of several cameras (see page 39).

Basic menu page 5

```

MARKER : ON
→DUR TIME:
MM:SS
00:00

```

Viewfinder Basic Menu

Item	Settings
MARKER Sets MARKER display ON/OFF.	ON (normal value), OFF MARKER is displayed when this setting is ON and is not displayed when it is OFF. When the setting is ON, go to Advanced Menu 4 to select the type of marker (see page 65).
DUR TIME Sets the recording time Setting the recording time before shooting helps you with making scenes of equal duration. When shooting with displaying the recording time of the current cut in the viewfinder (with the REC TIME switch set to DUR), the recording time indication flashes to remind you that the recording time has passed.	00:00 to 59:59 (minute to second) See "Setting the recording time in seconds" below.

Setting the recording time in seconds

Move the cursor to DUR TIME, then press the UP/ON button or DOWN/OFF button.

A value of seconds is displayed under "SS".

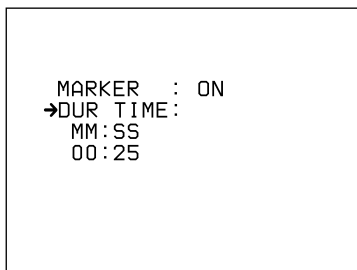

Basic menu page 6

The following display is shown when the DSR-1/IP is connected.



Item	Settings
MARK/CUE Selects MARK mode or CUE mode	MARK (normal value), CUE See "Using the ClipLink Function" (page 46).
CHG REEL NO Sets the cassette name/number	See "To set the cassette name/number" below.

To set the cassette name/number (when using DSR-1/IP)

- 1 Connect the DSR-1/IP and load a cassette.
- 2 Press the MENU/STATUS switch to move the cursor to CHG REEL NO, then press the UP/ON button.

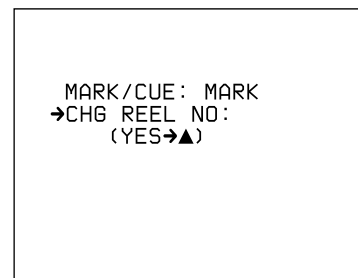

The cursor (→) changes to the text entry arrow (↓) and the current cassette name/number is displayed. ("NO TAPE" is displayed if you neglected to load a cassette.)

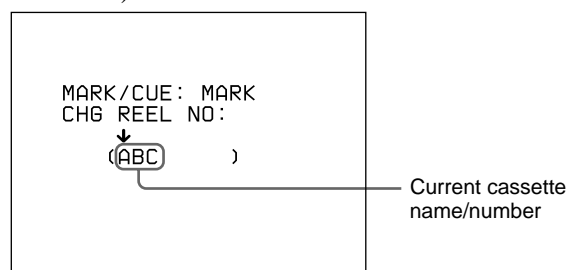

- 3** Press the MENU/STATUS switch to move the text entry arrow.

Press the MENU/STATUS switch upward to move the cursor to the right or downward to move it to the left.

The character cycles through the following sequence.

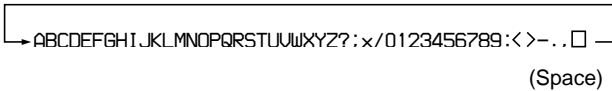

(Space)

- 4** Press the UP/ON button or DOWN/OFF button to enter the desired characters.

The displayed character changes each time the UP/ON button is pressed. It changes in reverse order each time the DOWN/OFF button is pressed.

- 5** Return to step **2** and repeat the text entry procedure.

- 6** After completing text entry, move the text entry cursor to the parenthesis position.

The display changes as follows.

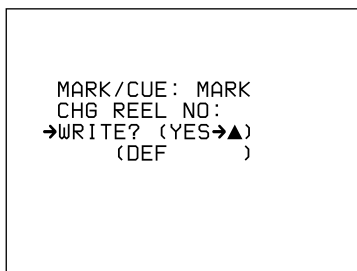

- 7** Check your cassette name/number setting, and press the UP/ON button if no more changes are required. (To make changes or to abort the procedure for this setting, return to step **2**.)

This writes the new cassette name/number to the cassette memory, after which the display changes as follows.

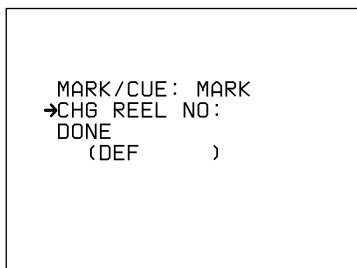

Basic menu pages 7 and 8

You can create a title of up to four lines, each of twelve alphanumeric or punctuation characters, and then save it. It is then possible to record the title over the picture while shooting.

Entering the title (page 7)

- 1** Press the MENU/STATUS switch as necessary to display basic menu page 7 (title setting display) in the viewfinder.

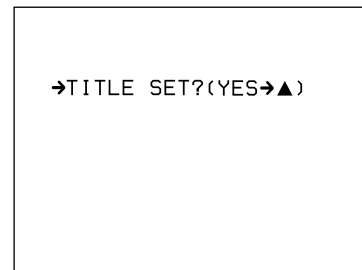

If a title is already present, it appears on this screen. To delete the displayed title, press the UP/ON and DOWN/OFF buttons simultaneously.

- 2** Press the UP/ON button. This brings up the cursor on the screen (flashing), and switches to title editing mode.

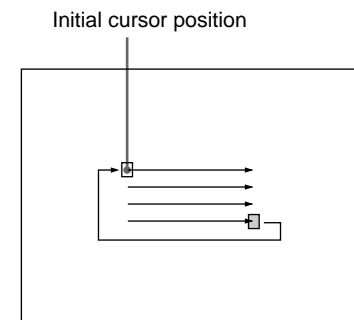

- 3** Press the DOWN/OFF button to move the cursor to the position where you wish to insert a character.

To move the cursor back

With the DOWN/OFF button held down, press the UP/ON button.

(continued)

Viewfinder Basic Menu

4 Press the UP/ON button to select the required character.
Each time you press the UP/ON button, the character cycles through the following sequence.

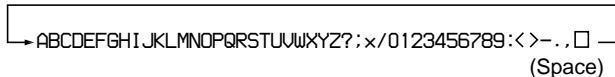

To reverse the character sequence

With the UP/ON button held down, press the DOWN/OFF button.

5 Press the DOWN/OFF button to confirm the character selection.
The cursor advances to the next character position.

To change a character after confirming it

Return to step 3, and input the character again.

6 Repeat steps 4 and 5 until the title is complete.

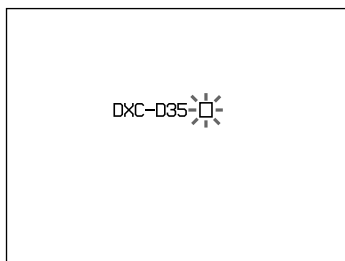

7 When the title is complete, press the MENU/STATUS switch as necessary to return to the normal viewfinder indications.
The title created is retained, even when you power the camera off.

To record a title (page 8)

1 Press the MENU/STATUS switch as necessary to access basic menu page 8 (title display).

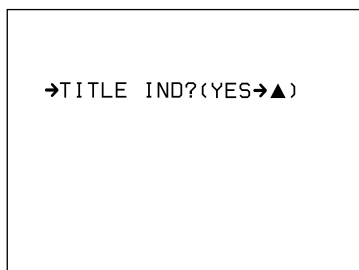

2 Press the UP/ON button once.

The title is superimposed to the picture displayed on the viewfinder screen.

3 Start shooting.

4 To stop the title recording, press the MENU/STATUS switch to clear the title display.

Note on using the CCU-M5/M5P Camera Control Unit

When the CCU-M5/M5P has a function switch setting of "TITLE ON", the title display takes precedence, and the status display (see page 57) do not appear in the normal incidations. However, when you press the MENU/STATUS switch up, for as long as you hold it up the status indications appear in place of the title.

When "CHECK DIAG" is displayed

The "CHECK DIAG" indication appears in the status display area whenever the camcorder's automatic self diagnostic function detects an abnormality. Access this page and perform error checking. (This page is displayed as basic menu page 1.)

"CHECK DIAG" will also be displayed if there is a problem on the sync signal input to the GEN LOCK IN connector. Input a proper sync signal and then perform error checking.



To perform error checking

Press the UP/ON button.

The error checking performs on the digital signal processing (DSP) and memory circuits and the results are displayed.

When no error is detected, "OK" appears.

Example: If an abnormality is detected in the DSP circuit.

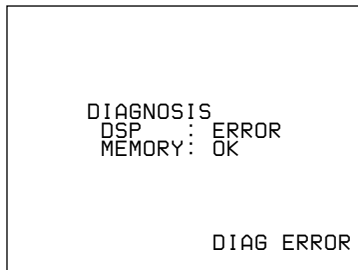

The error message “DIAG ERROR” appears when the normal indications are displayed. If this message appears, contact your Sony dealer.



Viewfinder Advanced Menu

Bring up the advanced menu pages by setting the POWER switch to ON while pressing the UP/ON button up (see page 52).

There are up to 15 advanced menu pages (the number displayed depends on the switch settings and the type of connected VTR).

Note on EZ mode

When the camera is in EZ mode, the advanced menu does not appear. Release the EZ mode beforehand. (See page 14.)

Advanced Menu Operations

To change the page

Move the cursor to the menu number, then press the UP/ON button or the DOWN/OFF button.

Pressing the UP/ON button displays the previous page and pressing the DOWN/OFF button displays the next page. Pressing the DOWN/OFF button when the last page is being displayed returns the display to the first page.

To select items in a page

Press the MENU/STATUS switch to move the cursor among the menu items.

To change settings

This operation is the same as for the basic menus.

For a description of basic menu operations, see page 58.

To return to the normal indications

Move the cursor to EXIT MENU, then press the UP/ON button.

Contents and Settings of Each Page

Each page's contents and settings are described below.

Advanced menu page 1

Use this page to return all advanced menu settings to their factory preset values.

For details of this operation, see "Displaying the advanced menu and switching to the normal indications" (page 52).

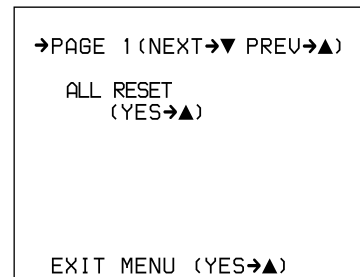

Advanced menu page 2

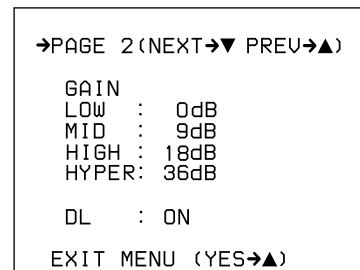

Item	Settings
GAIN This sets gain values for the positions of the GAIN switch. The HIGH, MID, and LOW values must be set so that LOW < MID < HIGH.	
LOW Sets the L position.	-3 dB, 0 dB (normal value), 3 dB, 6 dB, 9 dB, 12 dB, 18 dB, 18 dB + DPR, 24 dB
MID Sets the M position.	0 dB, 3 dB, 6 dB, 9 dB (normal value), 12 dB, 18 dB, 18 dB + DPR, 24 dB, 24 dB + DPR
HIGH Sets the H position.	3 dB, 6 dB, 9 dB, 12 dB, 18 dB (normal value), 18 dB + DPR, 24 dB, 24 dB + DPR, HYPER GAIN
HYPER Sets gain value when the HYPER GAIN is selected.	36 dB (normal value), 42 dB
DL Sets DynaLatitude function ON/OFF. This setting is valid only when the OUTPUT/DL/DCC+ switch has been set to DL.	ON (normal value), OFF When set to ON, the amount of DynaLatitude effects is set in basic menu page 3 (see page 59).

Advanced menu page 3

```

→PAGE 3 (NEXT→▼ PREV→▲)

AWB MEM : 2
TONE : OFF
BARS : SMPTEa)
REMOTE1 : REC
REMOTE2 : MARK
BAUD RATE : 38400

EXIT MENU (YES→▲)
    
```

a) For DXC-D35P/D35WSPL: EBU75

Advanced menu page 4

```

→PAGE4 (NEXT→▼ PREV→▲)

MARKER : CENT/90%
LIMITS : OFF
ZEBRA : 1
ZEBRA1 : 70IREa)
VF S DTL : ±0
VF TALLY : ×2
VF PLAY : Y
LENS SEL : 1

EXIT MENU (YES→▲)
    
```

a) For DXC-D35P/D35WSPL: 70%

Item	Settings
AWB MEM Selects whether or not to make the FILTER knob settings (1 to 4) correspond to separate white balance adjustment values stored in memory.	2 (normal value): No correspondence with FILTER knob settings. Only two adjustment values (A and B) are stored in memory. 2 × 4FL: Correspondence with FILTER knob settings. Each of the four knob settings can be used to set A and B adjustment values, for a total of eight settings.
TONE Selects whether or not to output a 1-kHz audio signal with the color bars when the OUTPUT/DL/DCC+ has been set to BARS.	ON (normal value): Output audio signal. OFF: Do not output audio signal.
BARS Selects normal width or narrower width for color bars.	SMPTE (normal value for DXC-D35/D35WSL): Normal width EBU75 (normal value for DXC-D35P/D35WSPL): EBU 75% EBU100 (for DXC-D35P/D35WSPL): EBU 100% SPLIT (for DXC-D35P/D35WSPL): Not for normal operation SNG: Narrower than normal (used for satellite communications, etc.)
REMOTE1 Sets a function for position 1 of a switch connected to the REMOTE1 connector.	REC (normal value): Specifies recording start/stop MARK: Specifies a Mark IN/OUT point. CUE: Specifies a cue point. NG: Specifies NG/OK.
REMOTE2 Sets a function for position 2 of a switch connected to the REMOTE1 connector.	REC: Specifies recording start/stop. MARK (normal value): Specifies a Mark IN/OUT point. CUE: Specifies a cue point NG: Specifies NG/OK.
BAUD RATE Sets a baud rate for a computer connected to the REMOTE connector 2 (to be supported in future version).	9600, 38400 (normal value)

Item	Settings
MARKER Selects ON/OFF setting for center marker, size setting (percentage of viewfinder screen area), and display ON/OFF setting.	CENT/90% (normal value): Displays center marker and safety zone marker at 90% size. CENT/80%: Displays center marker and safety zone marker at 80% size. 90%: Displays only safety zone marker at 90% size. 80%: Displays only safety zone marker at 80% size. CENT: Displays only center marker.
LIMITS (For DXC-D35WSL/D35WSPL) Selects the safety zone size when the scan size is 16:9.	OFF (normal value): FDepends on the scan size. 4:3, 13:9, 14:9, 15:9
ZEBRA Selects type of zebra pattern display.	1 (normal value): Displays the zebra pattern over parts having a video level between 70 and 90 IRE (or 70 and 90%). Use the next item (ZEBRA1) to select the base level. 2: Displays the zebra pattern over parts having video levels of 100 IRE or above (or 100% or above). 1/2: Dual display (both 1 and 2)
ZEBRA1 Sets base level for zebra pattern 1.	70 IRE (normal value) to 90 IRE or 70% (normal value) to 90% Can be set for each IRE step or 1% step.
VF S DTL Sets the detail level of images on the viewfinder screen (displayed only when a viewfinder other than the DXF-701/701CE/701WS/701WSCE/801/801CE is attached).	-99 to ±0 (normal value) to +99 Negative values set softer edges and positive values set sharper edges.

(continued)

Viewfinder Advanced Menu

Item	Settings
VF TALLY Selects whether or not to use more than one REC/TALLY indicators in the viewfinder (displayed only when the DXF-701/701CE/701WS/701WSCE/801/801CE viewfinder is attached).	×1: Uses only the upper REC/TALLY indicator. ×2 (normal value): Uses two REC/TALLY indicators.
VF PLAY Selects the video signal displayed in the viewfinder during playback of the DSR-1/1P (displayed only when the DSR-1/1P is connected)	Y (normal value): Y signal VBS: Composite video signal
LENS SEL Selects the types of the lens.	1 (normal value), 2, 3, 4 For details, see "Designating the lens" on page 90.

Advanced menu page 5

→PAGE 5 (NEXT→▼ PREVIOUS→▲)	
SS	IND: ALWAYS
LL	IND: ON
MIC	IND: ON
IRIS	IND: ON
GAIN	IND: ON
FILTER	IND: ON
WHITE	IND: ON
SKIN	IND: ON
EXIT MENU (YES→▲)	

Item	Settings
SS IND^{a)} Selects the mode for showing the shutter setting when displaying the normal indications.	3SEC: Displays shutter setting for three seconds only when the setting has been changed. ALWAYS (normal value): Displays the shutter setting at all times.
LL IND^{a)} Selects whether or not to show the LOW LIGHT indication on the normal indications when inadequate lighting is detected.	ON (normal value): Displays. OFF: Not display.
MIC IND^{a)} Selects whether or not to show the camera microphone output indication on the normal indications.	ON (normal value): Displays. OFF: Not display.
IRIS IND^{a)} Selects whether or not to show the lens's F-stop value (iris indication) on the normal indications. The F-stop value is always displayed when in EZ mode.	ON (normal value): Displays. OFF: Not display.

Item	Settings
GAIN IND^{a)} Selects whether or not to always show the gain setting indication on the normal indications.	ON (normal value): Always displays. OFF: displays for two seconds only when the setting has been changed.
FILTER IND^{a)} Selects whether or not to always show the FILTER knob setting indication on the normal indications. The FILTER knob setting indicator is always displayed when in EZ mode.	ON (normal value): Always displays. OFF: Displays for two seconds only when the setting has been changed.
WHITE IND^{a)} Selects whether or not to show the setting of the white balance switch.	ON (normal value): Displays. OFF: Not display.
SKIN IND^{a)} Selects whether or not to show the setting for skin detail correction.	ON (normal value): Displays. OFF: Not display.

a) When the viewfinder's DISPLAY switch is set to OFF, indications related to these items are not displayed even when menu settings are set to ON.

Advanced menu page 6

→PAGE 6 (NEXT→▼ PREVIOUS→▲)	
AUDIO	IND: ON
TAPE	IND: ON
TC	IND: ON
ID	IND: OFF
ID	SET: ↓
()	
EXIT MENU (YES→▲)	

Item	Settings
AUDIO IND^{a)} Selects whether or not to show the audio level indication on the normal indications (valid only when the DSR-1/1P or PVV-3/3P is connected).	ON (normal value): Displays. OFF: Not display.
TAPE IND^{a)} Selects whether or not to show the VTR's remaining tape indication on the normal indications. (valid only when the DSR-1/1P or PVV-3/3P is connected).	ON (normal value): Displays. OFF: Not display.

a) When the viewfinder's DISPLAY switch is set to OFF, indications related to these items are not displayed even when menu settings are set to ON.

Item	Settings
TC IND^{a)} Selects whether or not to show the time data indication on the normal indications (valid only when the DSR-1/1P or PVV-3/3P is connected).	ON (normal value): Displays. OFF: Not display.
ID IND Selects whether or not to display the camera ID when displaying color bars.	ON (normal value): Displays. OFF: Not display.
ID SET Sets the camera ID (up to eight characters, including alphanumerics, symbols, and spaces).	See "To set the camera ID" below.

a) When the viewfinder's DISPLAY switch is set to OFF, indications related to these items are not displayed even when menu settings are set to ON.

To set the camera ID

1 Press the MENU/STATUS switch to move the cursor to ID SET.

The cursor (→) changes to the text entry arrow (↓).

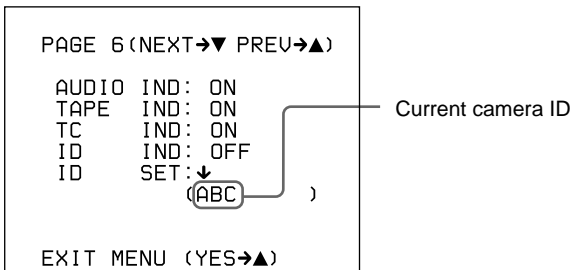

2 Press the MENU/STATUS switch to move the text entry arrow.

Press the MENU/STATUS switch upward to move the cursor to the right or downward to move it to the left.

3 Press the UP/ON button or DOWN/OFF button to enter the desired characters.

The displayed character changes each time the UP/ON button is pressed. It changes in reverse order each time the DOWN/OFF button is pressed.

4 Return to step 2 and repeat the text entry procedure.

5 When you have finished entering the text, move the cursor to the parenthesis position.

This clears the displayed menu and returns to the normal indications.

Advanced menu page 7

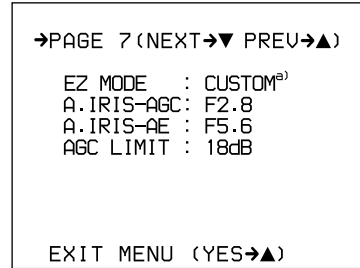

a) At shipping, the EZ MODE is set to STD.

Item	Settings
EZ MODE When the EZ MODE button has been set to EZ mode ON, this selects whether or not to change the settings of other switches and menus to the standard settings. (The EZ mode function cannot be used during remote operation.)	STD (normal value): Changes settings to standard settings. CUSTOM: Changes only some settings to standard settings. <i>For details of the settings when STD or CUSTOM is specified, see "EZ mode settings" on next page.</i>
A.IRIS-AGC Selects auto iris adjustment which sets an F-stop value that can be switched to AGC (displayed only when the EZ MODE is set to CUSTOM).	F1.8, F 2.8 (normal value), F4, F5.6
A.IRIS-AE Selects auto iris adjustment which sets an F-stop value that can be switched to AE (displayed only when the EZ MODE is set to CUSTOM).	F5.6 , F8, F11, F16 (normal value)
AGC LIMIT Sets an upper limit value for AGC adjustment (displayed only when the EZ MODE is set to CUSTOM).	0 dB, 3 dB, 6 dB, 9 dB, 12 dB (normal value)

Viewfinder Advanced Menu

EZ mode settings

The following settings are set for the camera head when EZ mode has been selected.

Item	Setting	
	STD	CUSTOM
Setup file	STD	Selectable
Detail level	±0	Selectable
Master black	±0	Selectable
Black stretch	±0	Selectable
Skin detail	OFF	OFF
Shutter	OFF (AE mode)	OFF (AE mode)
Freeze mix	OFF	OFF
Gain	AGC mode	AGC mode
Hyper gain	OFF	OFF
Iris control method	Automatic	Automatic
Auto iris control mode	STD	STD
Iris override	±0	Selectable
Color bar output	Not output	Not output
AGC upper limit	12dB	Selectable
AGC's F stop value	F2.8	Selectable
AE's F stop value	F16	Selectable
ATW	ON	ON
DynaLatitude	OFF	OFF
DCC+	ON	ON
F-stop value indication	ON	ON
Filter indication	ON	ON
Clock indication	OFF	OFF

Advanced menu page 8

```

→PAGE 8 (NEXT→▼ PREVIOUS→▲)

CLOCK IND: OFF
CLOCK SET: (START→▲)

YY MM DD
00 01 01
0:00 AM

EXIT MENU (YES→▲)
    
```

Item	Setting
CLOCK IND Selects whether or not to display the date/time on the normal indications.	OFF (normal value): Not display. CAM: Displays. BARS: Displays only when color bars are displayed.
CLOCK SET Sets date/time.	See "Setting the Clock and Timestamping Recordings" (page 86).

Advanced menu page 9

```

→PAGE9 (NEXT→▼ PREVIOUS→▲)

16:9/4:3 : 16:9
WIDE ID : ON
VF SCAN : AUTO
MENU MODE: 1

EXIT MENU (YES→▲)
    
```

Item	Settings
16:9/4:3 Selects whether to put the camera in 16:9 mode or 4:3 mode.	16:9 (normal value) 4:3^{a)}
WIDE ID Selects whether or not to add a wide aspect ID signal to video output signals in 16:9 mode.	ON (normal value): Adds. OFF: Does not add.
VF SCAN Selects 16:9 or 4:3 as the viewfinder scan size when using the supplied DXF-801/801CE Viewfinder.	AUTO (normal value): Automatically switch to 16:9 size when the camera is in 16:9 mode, and automatically switch to 4:3 size when the camera is in 4:3 mode. ^{a)} FULL: Regardless of camera's mode (16:9 ^{b)} or 4:3), the viewfinder picture completely fills the display area.
MENU MODE Selects whether or not switch the mode (16:9/4:3) on the basic menu.	1 (normal value): Selects the 16:9 or 4:3 mode only with the advanced menu. 2: Selects the 16:9 or 4:3 mode with both the basic and advanced menus.

- Compared to 16:9 mode, the 4:3 mode video appears as if a zoom lens has been adjusted slightly toward the telephoto end (see figure on page 70).
- When the camera is in 16:9 mode, the viewfinder picture appears stretched vertically (see figure on page 70).

Advanced menu pages 10 to 13

These pages are displayed only when the SET UP switch has been set to FILE.

For details of this operation, see “Setup Files” (page 71).

Advanced menu pages 14 and 15

These pages are displayed only when a DSR-1/1P has been connected and the SET UP switch is set to FILE.

For details of this operation, see “Using SetupNavi and SetupLog with the DSR-1/1P” (page 76).



Viewfinder Advanced Menu

Video Output and Viewfinder Picture (For DXC-D35WSL/D35WSPL)

The video output and viewfinder picture of this camera vary as shown below according to the settings of the 16:9/4:3 item and the VF SCAN item of the advanced menu page 9.

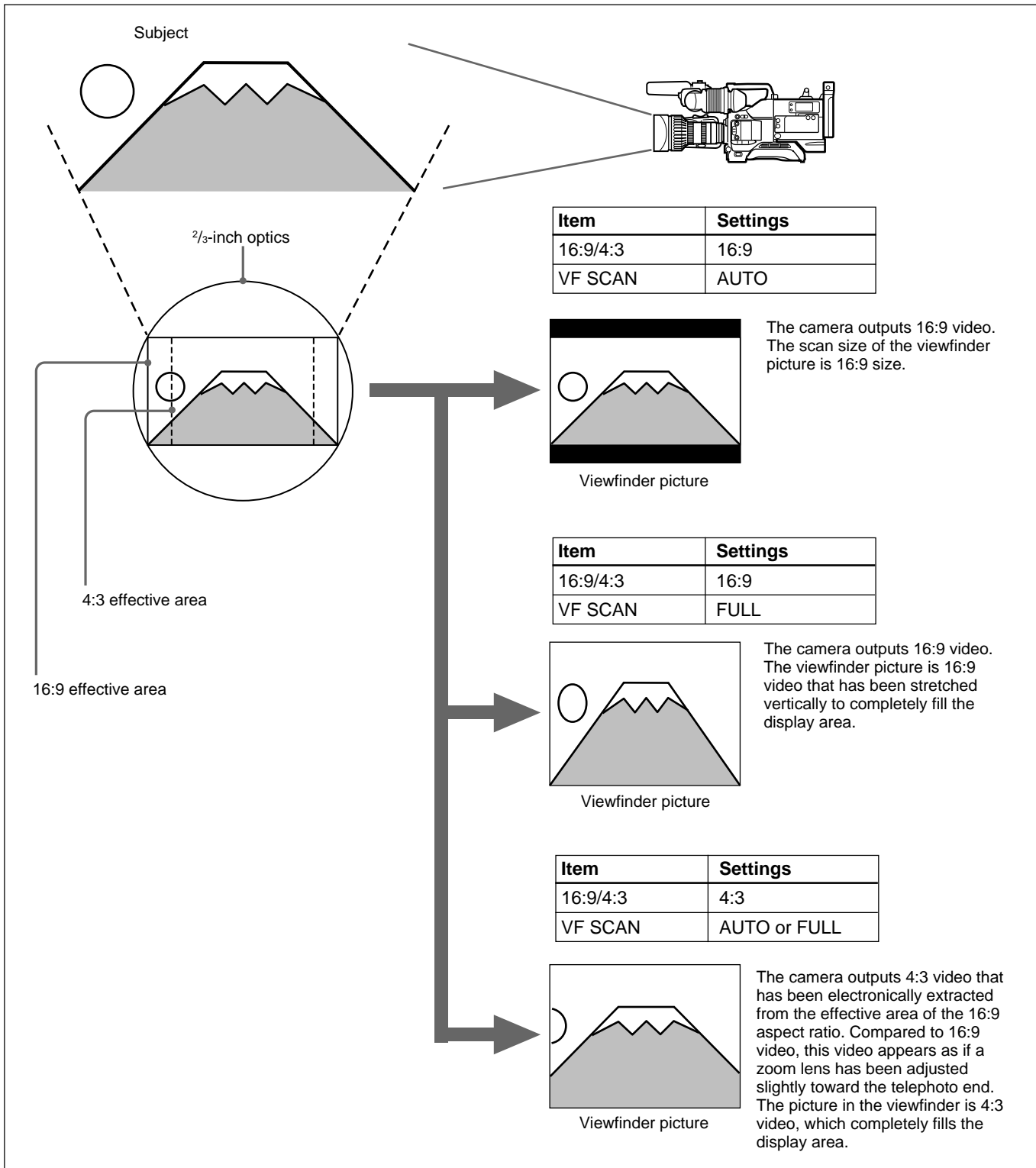

Setup Files

You can use setup files to reproduce a particular configuration of settings. You can also revise the contents of setup files.

There are eight types of setup files, of which five are factory preset setup files and the other three are user files.

Calling up a Setup File

This describes how to call up a setup file and use it to replace the current menu settings.

- 1 Set the SET UP switch to FILE.

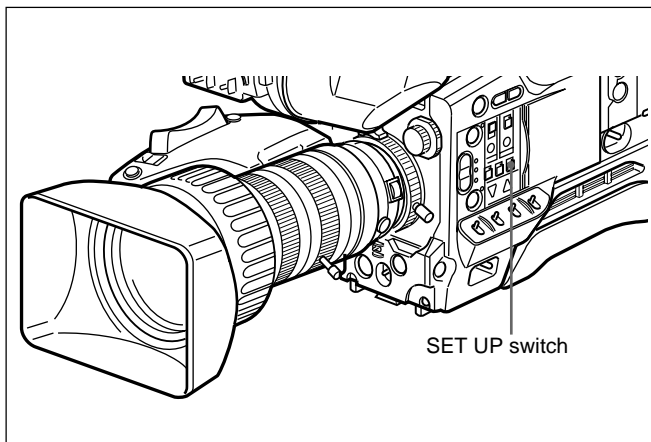

The camera head is set according to the currently-selected file data.

- 2 Access basic menu page 3.

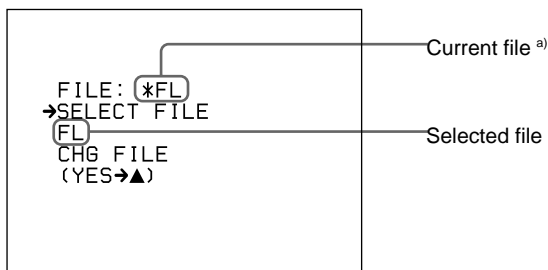

a) An asterisk (*) appears in front of any factory preset file whose contents have been revised at least once.

- 3 Move the cursor to SELECT FILE and use the UP/ON button or the DOWN/OFF button to select the desired file.

Press the UP/ON button or DOWN/OFF button repeatedly until the desired file name is displayed.

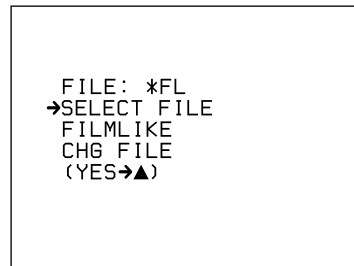

File	Description
STD	Settings for shooting under standard conditions
HI SAT	Settings for making pictures vivid
FL	Settings for shooting under fluorescent lighting
FILMLIKE	Settings for making pictures like ones shot by film camera
SVHS/VHS	Settings to optimize camera image for recording and playback characteristics of S-VHS, VHS, or Hi-8 tape
USER1 to USER3	User setup files (set to STD at shipping)

- 4 Move the cursor to CHG FILE and press the UP/ON button.

The display changes as shown below and the selected file is called up.

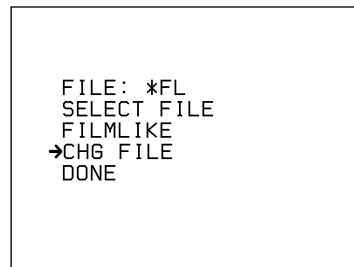

You can also call up these files via a similar operation in advanced menu page 10. In this page, a file recorded onto a tape can also be called up (when using the DSR-1/1P).

For details, see "To call up files recorded onto a tape (when using the DSR-1/1P)" (page 72).

Setup Files

To call up files recorded onto a tape (when using the DSR-1/1P)

First, connect the DSR-1/1P to the camera head and load the cassette that contains the recorded files.

1 Set the SET UP switch to FILE.

2 Access advanced menu page 10.

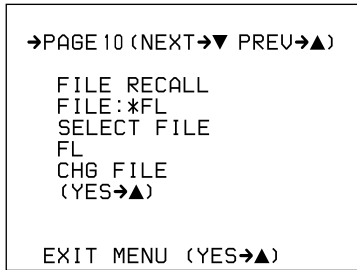

3 Move the cursor to SELECT FILE and use the UP/ON button or the DOWN/OFF button to select TAPE.

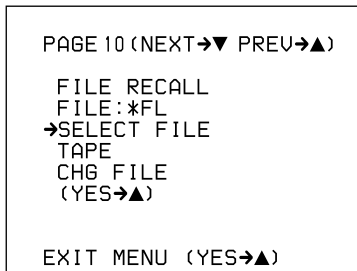

4 Move the cursor to CHG FILE and press the UP/ON button.

The screen appears as shown below.

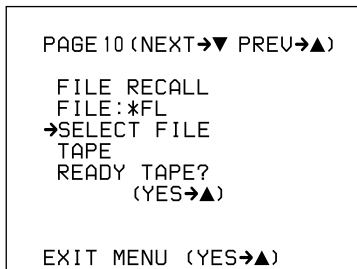

5 Press the UP/ON button to call up the file. To abort the call up operation, press the DOWN/OFF button (the display returns to the one shown in step 3).

During the call up operation, the following display appears.

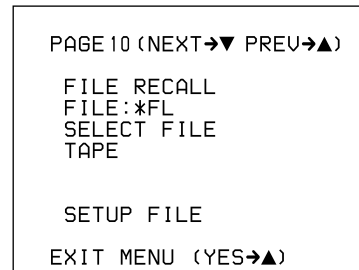

When the call up operation ends, the display changes as shown below.

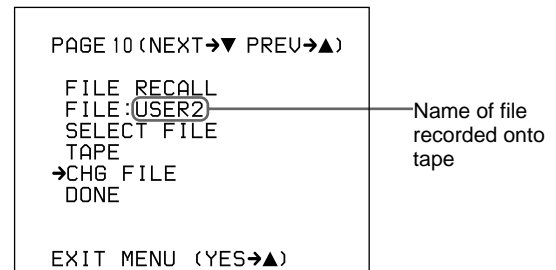

The settings of the camera head are now replaced by the settings in the called file.

Changing File Settings

When using advanced menu page 11 or 12, you can change the settings about picture quality in setup files. (In basic menu page 1, a part of items are changeable.) The changes are accepted only until another file is called up, after which the original settings are restored. If you save the changes, store the modified file as one of the user files or record it in a cassette. (See the following section “Saving File Settings”.)

- 1 Perform the steps described in “To call up files recorded onto a tape (when using the DSR-1/1P)” above to call up the selected file.
- 2 Access advanced menu page 11 or 12.

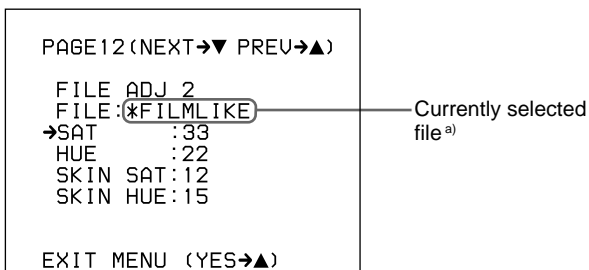
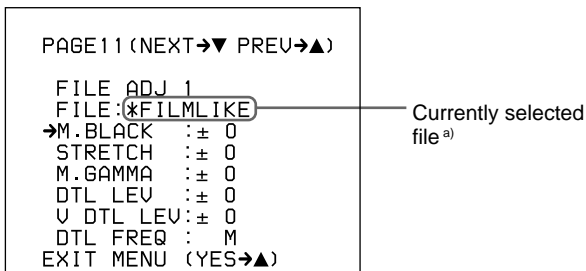

a) An asterisk (*) appears in front of any factory preset file whose contents have been revised at least once.

- 3 Make the desired changes.

Page 11

Item	Settings
M.BLACK, STRETCH and DTL LEV	See “Basic menu page 1” (page 58).
M.GAMMA Adjusts the gamma curve.	-99 to ±0 (normal value) to +99
V DTL LEV Adjusts the vertical detail.	-99 to ±0 (normal value) to +99
DTL FREQ Adjusts the central frequency of the detail.	LL, L, M (normal value), H, HH

Page 12

Item	Settings
SAT Adjusts the saturation of the image.	-99 to ±0 (normal value) to +99 Negative adjustment values decrease the saturation and positive adjustment values increase the saturation.
HUE Adjusts the hue of the image.	-99 to ±0 (normal value) to +99
SKIN SAT Adjusts the saturation in the specified area of the image.	-99 to ±0 (normal value) to +99 Negative adjustment values decrease the saturation and positive adjustment values increase the saturation.
SKIN HUE Adjusts the hue in the specified area of the image.	-99 to ±0 (normal value) to +99

Saving File Settings

Files whose settings have been changed for certain shooting conditions can be saved as a user file or onto a tape (when using the DSR-1/1P).

For details, see “To save setup files to a tape (when using the DSR-1/1P)” (page 74).

- 1 Set the SET UP switch to FILE.

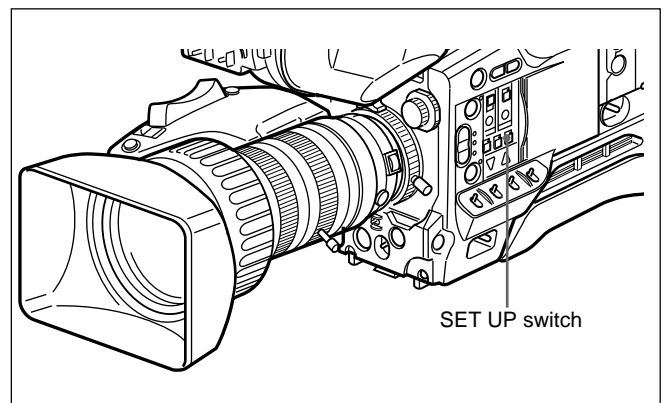

- 2 Call up a setup file whose settings approximate the desired shooting conditions and then change some of the settings.

For details of this operation, see “Calling up a Setup File” (page 71), “Changing File Settings” (in the left column on this page), “Basic Menu Operations” (page 58), and “Advanced Menu Operations” (page 64).

(continued)

Setup Files

3 Access advanced menu page 13.

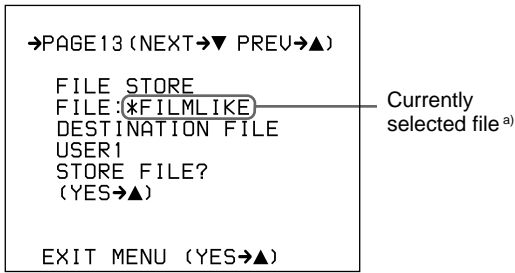

a) An asterisk (*) appears in front of any factory preset file whose contents have been revised at least once.

4 Move the cursor to DESTINATION FILE and repeatedly press the UP/ON button or the DOWN/OFF button to select USER1, USER2, or USER3.

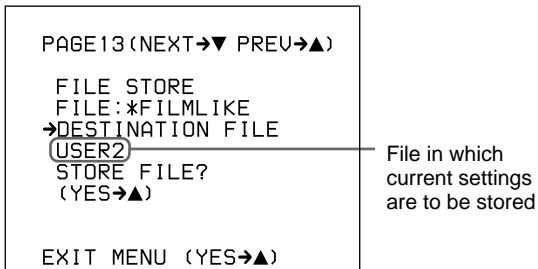

5 Press the UP/ON button to move the cursor to STORE FILE?.

The display changes as shown below.

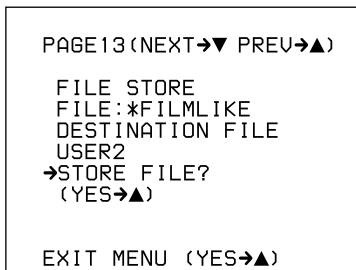

6 Press the UP/ON button to store the file. To abort the save operation, press the DOWN/OFF button (the display returns to the one shown at step 4).

When the save operation is finished, the display changes as shown below.

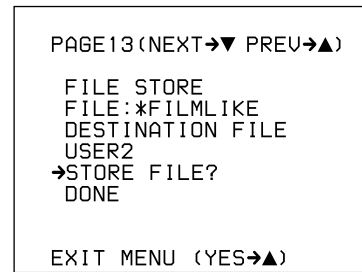

To save setup files to a tape (when using the DSR-1/1P)

Connect the DSR-1/1P to the camera head and load the tape onto which the file will be recorded.

1 Perform steps 1 to 4 of “Saving File Settings” and select TAPE as the file saving destination.

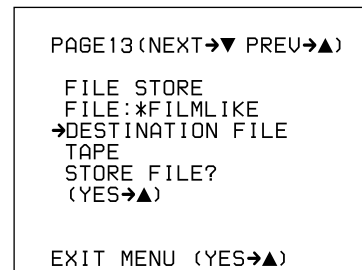

2 Press the UP/ON button to move the cursor to STORE FILE?.

The display changes as shown below.

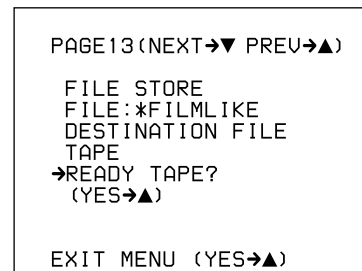

-
- 3** Press the UP/ON button to store the file. To abort the save operation, press the DOWN/OFF button (the screen returns to the screen shown in step 2).

The tape automatically rewinds and recording starts.

The display changes as shown below. (“CAN NOT WRITE” appears on the screen if no tape is loaded or if the loaded tape is write-protected.)

```
PAGE13 (NEXT→▼ PREV→▲)
FILE STORE
FILE:*FILMLIKE
→DESTINATION FILE
TAPE
EXIT MENU (YES→▲)
```

After the settings are stored, the following display appears.

```
PAGE13 (NEXT→▼ PREV→▲)
FILE STORE
FILE:*FILMLIKE
DESTINATION FILE
TAPE
→STORE FILE?
DONE
EXIT MENU (YES→▲)
```



Using SetupNavi and SetupLog with the DSR-1/1P

The SetupNavi function records the setup menu and setup files onto a tape, so that the same settings can be called up and used again or copied to another camera. The SetupLog function records a camera settings every few seconds at shooting and displays the recorded data in the viewfinder during playback.

Note on using an RM-M7G Remote Control Unit

When an RM-M7G is connected to the camera head, you cannot use the SetupNavi function. To make it possible to use the function, power OFF the camera head after disconnecting the RM-M7G, then power ON the camera head again.

Setting up the Camera Using Data Recorded on Tape

The procedure to replace camera's menu settings with settings recorded onto video tape is described here.

- 1 Connect the DSR-1/1P and insert the cassette onto which the data was recorded. Set the SETUP switch to FILE, then set the POWER switch to ON while holding down the UP/ON button.

Advanced menu page 1 appears.

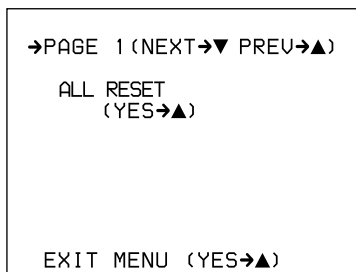

- 2 Repeatedly press down on the MENU/STATUS switch until advanced menu 14 appears.

For details of menu operation, see "Advanced Menu Operations" (page 64).

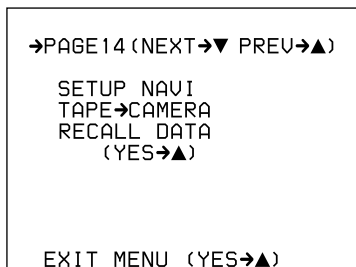

"NO TAPE" is displayed if you neglected to load a cassette.

- 3 Press the UP/ON button to call up the data recorded on the tape. (Press the DOWN/OFF button to cancel).

The display changes as follows and the call up operation begins.

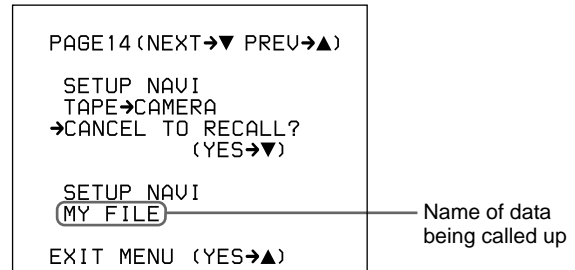

To abort the call up operation while in progress Press the DOWN/OFF button.

The following display appears.

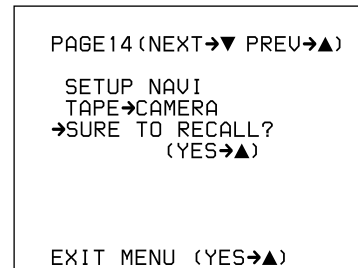

- 4 Press the UP/ON button.

After the data has been read, the following display appears.

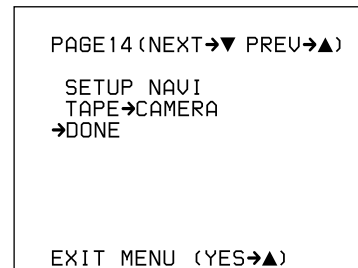

The previous menu settings are overwritten by the data recorded on the tape.

- 5 Change the menu settings if necessary.

Recording the Menu Settings onto a Tape

1 Connect the DSR-1/IP and load the tape onto which the settings are to be recorded. Turn the camera power on.

2 Make your basic menu settings.

For details of this operation, see “Basic Menu Operations” (page 58).

3 Again, set the POWER switch to ON while holding down the UP/ON button.

4 Make your advanced menu settings.

For details of this operation, see “Advanced Menu Operations” (page 64).

5 Access advanced menu page 15.

```

→PAGE15 (NEXT→▼ PREU→▲)
  SETUP NAVI
  CAMERA→TAPE
  STORE DATA
    (YES→▲)

EXIT MENU (YES→▲)
  
```

“NO TAPE” appears if you neglected to load a cassette.

6 Press the UP/ON button.

The following display appears.

```

PAGE15 (NEXT→▼ PREU→▲)
  SETUP NAVI
  CAMERA→TAPE
  →SURE TO STORE?
    (YES→▲)
  NAME SET :
    (YES→▲)
  ( )
  EXIT MENU (YES→▲)
  
```

7 Set the cursor to “NAME SET” and press the UP/ON button to record the menu setting onto the tape. (Press the MENU/STATUS switch to cancel.)

The cursor (→) changes to the text entry cursor (↓).

```

PAGE15 (NEXT→▼ PREU→▲)
  SETUP NAVI
  CAMERA→TAPE
  SURE TO STORE?
    (YES→▲)
  NAME SET :
    ↓
  ( )
  EXIT MENU (YES→▲)
  
```

8 Enter a name for the data.
Moving the text entry cursor: Press the MENU/STATUS switch up to move the cursor to the right, and press the MENU/STATUS switch down to move the cursor to the left.

Selecting the character: Press the UP/ON or DOWN/OFF button repeatedly until the desired character appears.

9 After completing text entry, move the cursor to the parenthesis position.

The display changes as follows.

```

PAGE15 (NEXT→▼ PREU→▲)
  SETUP NAVI
  CAMERA→TAPE
  SURE TO STORE?
    (YES→▲)
  →NAME SET
    (YES→▲)
  MY FILE
  EXIT MENU (YES→▲)
  
```

10 Move the cursor to “SURE TO STORE?” and press the UP/ON button to record the menu settings onto the tape (press the MENU/STATUS switch to cancel).

The display changes as follows and the data recording begins.

```

PAGE15 (NEXT→▼ PREU→▲)
  SETUP NAVI
  CAMERA→TAPE
  →CANCEL TO STORE?
    (YES→▲)

  SETUP NAVI
  (MY FILE)
  EXIT MENU (YES→▲)
  
```

Name of data being recorded

Using SetupNavi and SetupLog with the DSR-1/1P

To abort the data recording while in progress

Press the DOWN/OFF button.

After the data has been recorded, the following display appears.

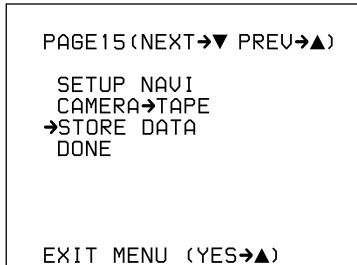

Viewing SetupLog Data

1 Connect the DSR-1/1P and load the tape that contains the recording to be viewed. Turn the camera power on.

2 Play back the tape.

For details of playback operation, see the operating instructions for the DSR-1/1P.

3 Press the MENU/STATUS switch up to the STATUS side.

The display changes to page 1 of the status display.

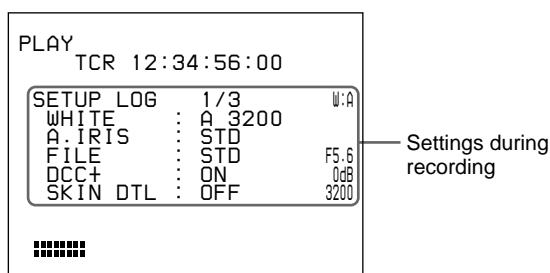

Each time you press upward the MENU/STATUS switch, the status display cycles through the status pages and playback display in the order: page 2, page 3, the playback display (containing the current settings), and page 1.

Status display (page 2)

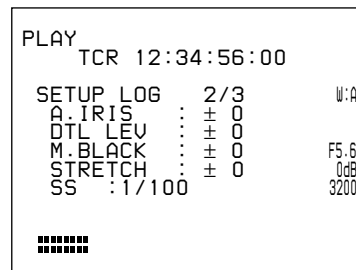

Status display (page 3)

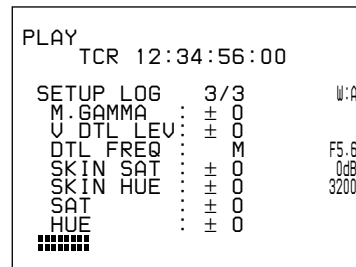

Notes

- SetupLog data is not recorded while SetupNavi data or a setup file is being recorded onto a tape. (If you play back a tape containing SetupNavi data or a setup file, the data displayed in the setup display is not the SetupLog data of the playback picture.)
- In the following cases, changed settings that were not recorded may appear as blank settings.
 - SetupLog data is overwritten at intervals of a few seconds during recording. If the settings are changed frequently for certain items, it may not always be recorded in time.
 - If the recording time is very short, recording may be ended before all of the data has been overwritten.

Adjustments and Settings

White Balance Adjustment

Adjusting the white balance ensures that as lighting conditions change white objects remain white in the image and tones remain natural.

The color of light emitted varies from one light source to another, and as the lighting changes the apparent color of an illuminated subject changes. It is therefore necessary to adjust the white balance each time the principal lighting source changes.

Saving an Appropriate White Balance Value in Memory

You can save two white balance values in separate memories, A and B. Unless changed, the saved values are retained for approximately ten years, even when the camera is powered off.

Once a value is saved, you can automatically restore the adjustment by moving the W. BAL switch to the A or B position. This makes shooting under alternating lighting conditions easy.

Separate white balance values for each FILTER control setting

In the default case, as described above, the same two A and B white balance values apply to all four settings of the FILTER control. It is possible, however, to change the AWB MEM menu setting is advanced menu page 3 (see page 65) so that there are eight possibly different values for the A and B positions and for the four FILTER control settings.

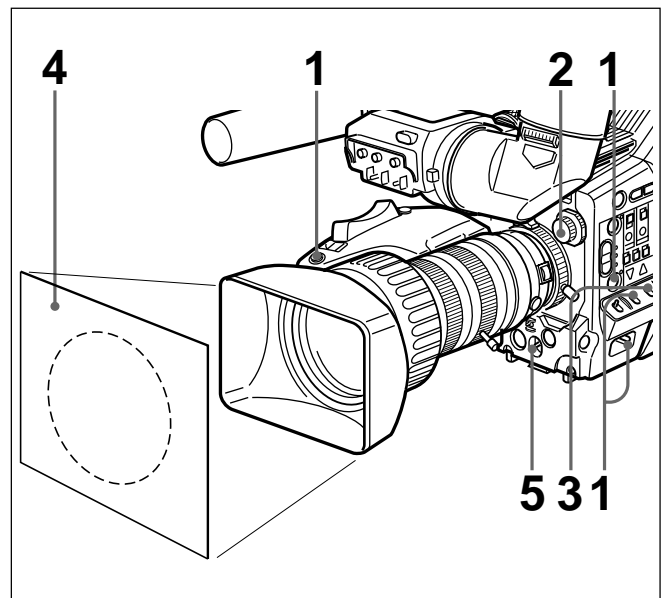

- 1** Make the following settings on the camera.
 - POWER switch: ON SAVE
 - OUTPUT/DL/DCC+ switch: one of the CAM positions
 - Lens iris selector: A (automatic)
 - ATW button: off
- 2** Set the FILTER control according to the lighting conditions. (See page 43.)
- 3** Set the W. BAL switch to A or B.

(continued)

White Balance Adjustment

4 Arrange a white subject (paper, cloth, etc.) under the same lighting conditions as for shooting, and zoom in on it so that as far as possible the whole screen is white.

The minimum white area requirements for the adjustment are shown in the following figure.

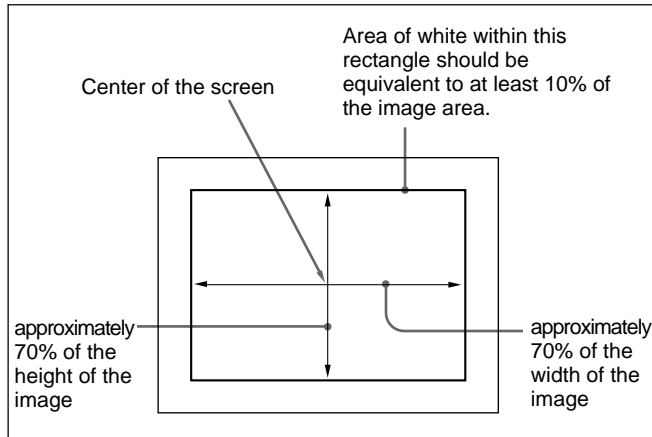

5 Push the WHT/BLK switch in the WHT direction and release.

The white balance adjustment is carried out. During the adjustment the legend “AUTO WHITE -OP-” appears in the viewfinder. After a few seconds the adjustment is complete, and the legend in the viewfinder changes to “AUTO WHITE -OK-” plus a color temperature, as shown in the following figure.

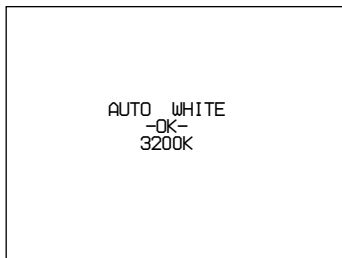

The adjustment value is automatically saved in memory A or B as selected above.

To save the white balance adjustment for different lighting conditions, repeat steps 2 to 4 above. You can save two different values for the white balance, in memories A and B.

Note

When using a camera control unit or remote control unit, if the W/B BALANCE switch of the control unit is set to PRESET or MANUAL, it is not possible to carry out white balance adjustment on the camera.

To recall a white balance value from memory

Before beginning shooting, set the W. BAL switch to the A or B position. This automatically sets the camera to the white balance adjustment saved in the corresponding memory.

If white balance adjustment cannot be completed automatically

The warning message “AUTO WHITE -NG-” appears in the viewfinder.

Make the necessary corrections, then carry out the process again.

Warning messages for white balance adjustment

Message	Meaning and corrections to be made
AUTO WHITE -NG- :LOW LIGHT TRY AGAIN	Light level is too low. <ul style="list-style-type: none"> • Increase the illumination level, open the iris, or use the GAIN switch to increase the video signal level. • Check the setting of the FILTER control. • After these checks, retry the adjustment.
AUTO WHITE -NG- : ?? TRY AGAIN	The subject is not white, or the lighting level is too high. <ul style="list-style-type: none"> • Use a white subject. • Lower the illumination level, stop down the iris, or use the GAIN switch to decrease the video signal level. • Check the setting of the FILTER control. • After these checks, retry the adjustment.
AUTO WHITE -NG- :C.TEMP.LOW CHG.FILTER TRY AGAIN	The color temperature is too low. Try the following, in this order of precedence. <ol style="list-style-type: none"> (1) If the FILTER control is in position 2, 3 or 4, change it to position 1, then retry the adjustment. (2) Check that the subject is completely white, then retry the adjustment. (3) The color temperature may be outside the range of the camera. Fit an appropriate color temperature conversion filter, then retry the adjustment.
AUTO WHITE -NG- :C.TEMP.HI CHG.FILTER TRY AGAIN	The color temperature is too high. Try the following, in this order of precedence. <ol style="list-style-type: none"> (1) If the FILTER control is in position 1, change it to position 2, 3 or 4, then retry the adjustment. (2) Check that the subject is completely white, then retry the adjustment. (3) The color temperature may be outside the range of the camera. Fit an appropriate color temperature conversion filter, then retry the adjustment.

Message	Meaning and corrections to be made
WHITE:PRESET	The W. BAL switch is in the PRESET position. Move the W. BAL switch to the A or B position.
BARS	The camera is outputting a color bar signal. Move the OUTPUT/DL/DCC+ switch to one of the CAM positions.

Using the Preset White Balance Settings

The camera provides two preset white balance settings, for instant shooting with approximately the correct adjustment. The preset white balance can be selected between 2200 K and 4300 K when the FILTER control is set to 1 and between 4600 K and 12000 K when the FILTER control is set to 2, 3 or 4 (see page 59). There are also particular shooting conditions under which the preset values may give better results than the human eye adjustment.

- 1 Set the W. BAL switch to PRESET.
- 2 Set the FILTER control.

The white balance is automatically adjusted for the preset white balance selected in basic menu page 2 (see page 59).

Light Sources and Color Temperature

Adjustment of the white balance to match the light source is essential to ensure correct color rendering. The color of a light source is indicated as a color temperature in kelvins (K). It is higher for bluish light, and lower for reddish light. When the camera is shipped it is adjusted for use with video lights (halogen lamps with a color temperature of 3200 K). For use with other light sources, therefore, adjustment is required.

First use the FILTER control to set the approximate color temperature, then carry out white balance adjustment.

The following table shows typical color temperature values for different light sources.

Color temperatures of different light sources

Light source		Color temperature (K)
Natural	Artificial	
Clear sky		10,000
Light cloud		8,000
Cloudy or rainy skies		Blue light 7,000
		6,000
	Fluorescent light (daylight white)	5,000
Direct sunlight, noon	Mercury lighting	White light
	Fluorescent light (white)	
One hour after sunrise or before sunset	Fluorescent light (warm white)	4,000
	Studio lighting	3,500
	Halogen lamps and video lights	Yellow light 3,200
		2,500
Thirty minutes after sunrise or before sunset	Incandescent lighting	
	Sodium street-lighting	
Sunrise or sunset	Candlelight	Red light 2,000

Using the ATW (Auto Tracing White Balance) Function

The ATW function continuously adjusts the white balance automatically to adapt to changes in lighting conditions.

Note

Depending on the shooting conditions, automatic adjustment may not necessarily give optimum results. For the best possible results, use the W. BAL switch.

To use the ATW function

Press the ATW button turning the indicator on. This activates the ATW function, and the ATW indication appears in the viewfinder.

To disable the ATW function, press the ATW button again, turning the indicator off.

White Balance Adjustment

If the ATW function does not operate correctly

A warning message appears in the viewfinder as shown in the table below.

Message	Meaning and corrections to be made
:C.TEMP.LOW	If the FILTER control is in position 2, 3 or 4, change it to position 1, then retry the ATW operation.
:C.TEMP.HIGH	If the FILTER control is in position 1, change it to position 2, 3 or 4, then retry the ATW operation.

Black Balance Adjustment

Correct adjustment of the black balance is important for optimum operation of a video camera. It is necessary when using the camera for the first time or after a significant period out of use, and also when there has been a sudden change in temperature. The adjustment value is saved in memory, and readjustment is not normally necessary after powering the camera off or simply when lighting conditions change.

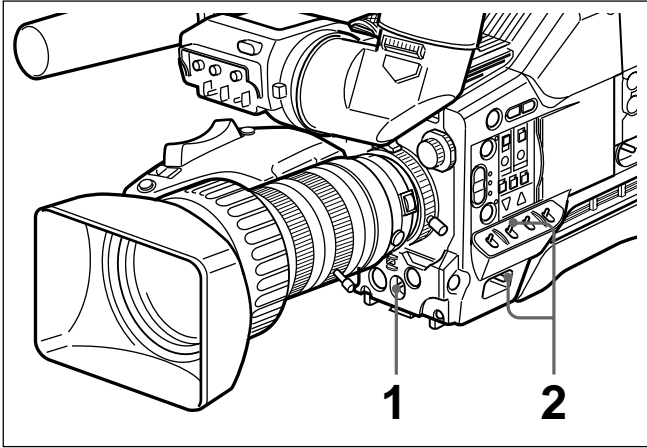

- 1** Move the POWER switch to the ON SAVE position, and check that the OUTPUT/DL/DCC+ switch is in one of the CAM positions.
- 2** Push the WHT/BLK switch in the BLK direction and release. The lens iris closes, and black balance adjustment is carried out. During the adjustment the legend “AUTO BLACK -OP-” appears in the viewfinder.

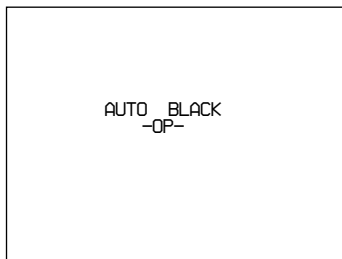

After a few seconds the adjustment is complete, and the legend in the viewfinder changes to “AUTO BLACK -OK-”.

Note

When using a camera control unit or remote control unit, if the W/B BALANCE switch of the control unit is set to MANUAL, it is not possible to carry out black balance adjustment on the camera.

If black balance adjustment cannot be completed automatically

The warning message “AUTO BLACK -NG-” appears in the viewfinder.

Make the necessary corrections, then carry out the process again.

Warning messages for black balance adjustment

Message	Meaning and corrections to be made
AUTO BLACK -NG- : IRIS NOT CLOSED TRY AGAIN	The lens iris did not close fully. Check whether the lens cable is connected properly, and whether there is a fault in the lens. If a second attempt to carry out the adjustment fails, consult your Sony dealer.
AUTO BLACK -NG- : ?? TRY AGAIN	The iris opened during adjustment or there is a hardware error. Close the iris and try again. If this fails, consult your Sony dealer.
BARS	The camera is outputting a color bar signal. Move the OUTPUT/DL/DCC+ switch to one of the CAM positions.

Shutter Settings

This section covers the settings for electronic shutter speed, CLS (clear scan) and EVS function.

The new value for the shutter speed or clear scan frequency and EVS setting remains set until changed, even when the camera is powered off.

Shutter speeds

There are five shutter speeds, from $1/100$ s (DXC-D35/D35WSL) or $1/60$ s (DXC-D35P/D35WSPL) to $1/2000$ s. Increasing the shutter speed reduces blurring when shooting a fast-moving subject. It is also possible to reduce flicker when shooting under fluorescent lighting by changing the shutter speed.

CLS (Clear Scan) function

When shooting a computer screen or projected image, horizontal bands may appear in the camera image. This is because the vertical scan frequency of the computer-generated image is different from the vertical scan frequency of the video system. The clear scan function allows you to select a vertical scan frequency to reduce this interference.

EVS (Enhanced Vertical Scan)

This function enhances the vertical scan resolution from 400 to 450 lines (or 450 to 530 lines) to reduce flicker. However, this increases the aliasing.

Setting the shutter speed, CLS and EVS function

Notes on setting the shutter speed

- The faster you make the shutter speed, the darker the image becomes. Check the brightness in the viewfinder, and if necessary increase the lighting level or adjust the iris.
- When the shutter speed is very fast, shooting a high intensity subject may cause long vertical tails to appear on the highlights (smear).

Note on setting the CLS function

The vertical scan frequencies of computer screens vary, and it may not be possible to eliminate the interference patterns entirely. Note also that the vertical scan frequency may change depending on the software being run.

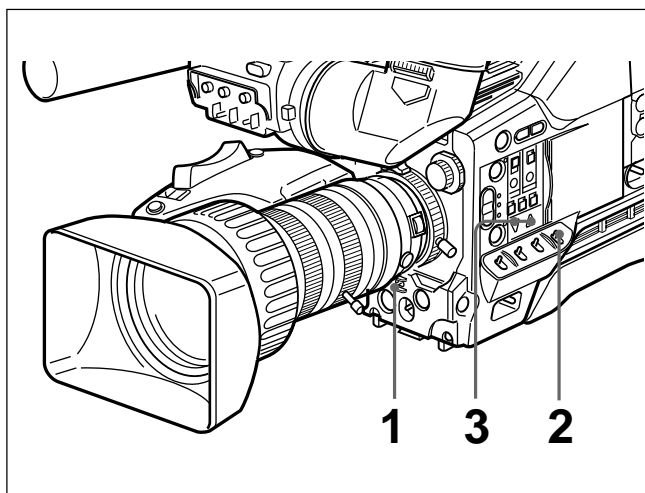

- 1 Set the SHUTTER switch to the ON position.

The SHUTTER indicator in the viewfinder comes on, and it is now possible to change the shutter speed or clear scan frequency setting and to set the EVS function. (If the EVS is already selected, the SHUTTER indicator will not light.)

- 2 Operate the MENU/STATUS switch to align the cursor with the item "SHUTTER" in basic menu page 1.

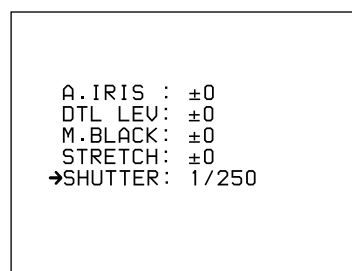

- 3 Press the UP/ON button or DOWN/OFF button to select the required shutter speed, scan frequency or EVS. Each time you press the UP/ON button or DOWN/OFF button, the shutter speed or clear scan frequency setting changes in the following order:

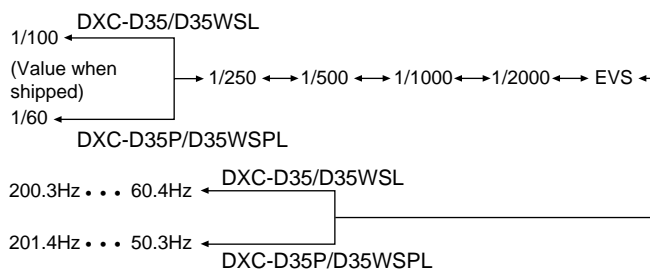

When using the clear scan function

Watching the monitor screen, adjust the frequency to give minimum interference.

If there is a black band in the monitor image, reduce the frequency, and if there is a white band, increase the frequency.

To return from the basic menu to the normal indications

Press the MENU/STATUS switch as many times as necessary until the normal indications appear. The new setting of the shutter speed or clear scan frequency appears in the normal screen display.

When shooting is finished

Set the SHUTTER switch to the OFF position. The SHUTTER indicator in the viewfinder goes off.



Setting the Clock and Timestamping Recordings

Use advanced menu page 8 to set the camera head's internal clock and record the date and time.

Note

If the following date/time setting procedure for the internal clock does not cause the date/time information to be displayed in advanced menu page 8, it may be due to a worn-out lithium battery in the camera head. See page 23 and replace the lithium battery.

How to set the date and time

1 Access advanced menu page 8.

For details of menu operations, see "Advanced Menu Operations" (page 64).

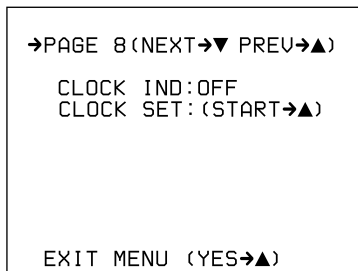

2 Move the cursor to CLOCK SET, then press the UP/ON button.

The following display appears, in which the year indication is flashing.

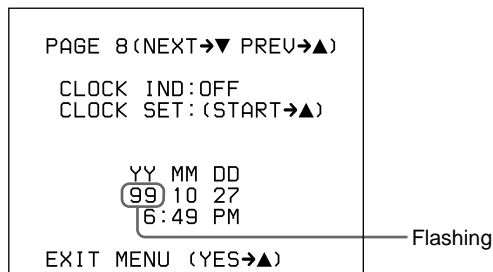

3 Press the MENU/STATUS switch and the UP/ON button to set the desired date and time.

- 1) Press the MENU/STATUS switch up or down until the item to be changed starts flashing.
- 2) Press the UP/ON button to change the number.

Repeat 1) and 2) until you have completed your date and time settings.

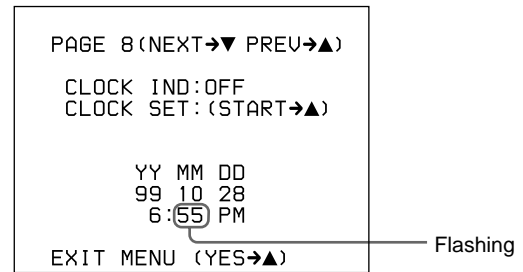

4 Select whether to display a 12-hour clock (showing AM and PM hours) or a 24-hour clock.

- 1) Press the MENU/STATUS switch up or down to select the desired setting (12-hour clock display or 24-hour clock display).

Example of 12-hour clock display: 6:49 PM ("6" and "PM" are flashing)

Example of 24-hour clock display: 18:49 ("18" is flashing)

- 2) Press the UP/ON button.

5 Press the UP/ON button to select the date display format.

Each press of the UP/ON button cycles through the following options.

- Year-month-day: YY MM DD
99 10 27
- Month-day-year: MM DD YY
10 27 99
- Day-month-year: DD MM YY
27 10 99

6 Press the MENU/STATUS switch down.

The cursor is shown at the CLOCK SET position.

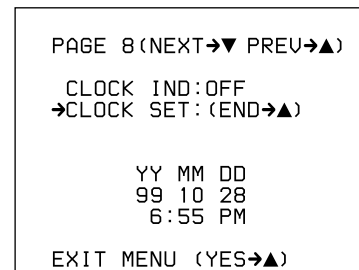

7 Press the UP/ON button (to a time signal).

The clock starts from 00 seconds. The clock display can be viewed if CLOCK IND has been set to ON.

Timestamping recordings

You can timestamp recordings by superimposing the current date and time.

- 1** Before shooting, set the CLOCK IND to CAM in advanced menu page 8.

The date and time appear in the viewfinder, and are superimposed on the video signal output from the camera.

- 2** To stop superimposing the date and time, set the CLOCK IND to OFF.

Viewfinder Screen Adjustments

The following adjustments are provided to improve the visibility of the viewfinder screen.

Although these adjustment may make the viewfinder image clearer, they have no effect on the output video signal from the camera.

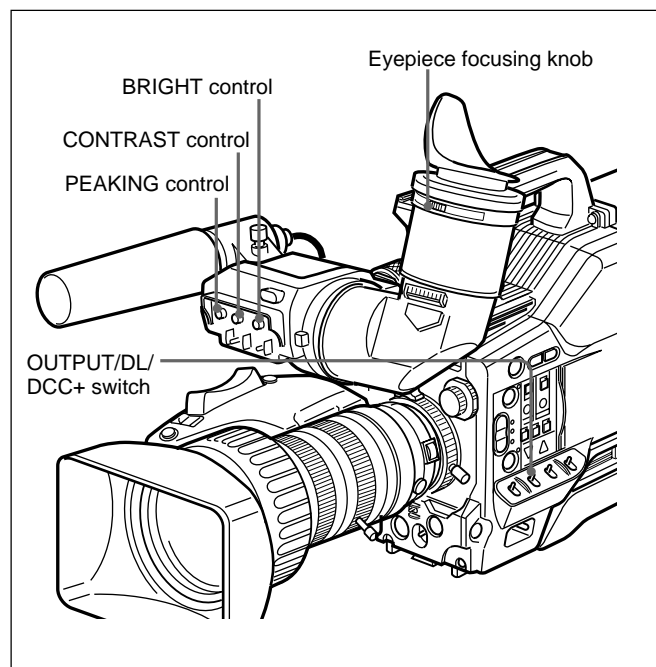

Contrast and brightness adjustment

Carry out these adjustments with the color bars displayed.

- 1** Set the OUTPUT/DL/DCC+ switch to the BARS position.
The color bars appear in the viewfinder.
- 2** Watching the color bars, turn the CONTRAST and BRIGHT controls to adjust the contrast and brightness.
- 3** Return the OUTPUT/DL/DCC+ switch to its original position.

Outline emphasis adjustment

Turning the PEAKING control changes the degree of outline emphasis in the viewfinder image, to make focusing easier.

Adjusting the eyepiece focus

Depending on the eyesight of the camera operator — whether longsighted or shortsighted — the optimal position of the viewfinder image varies. Adjust the eyepiece focus to get the clearest viewfinder image for your eyesight. First focus the image with the lens, then adjust the eyepiece focusing knob. The adjustment range is from -3 to 0 diopters¹⁾ (default when shipped is 0 diopters).

Using an optional part allows you to modify the adjustment range to -2 to $+1$ diopters or -0.5 to $+3$ diopters.

For details, consult your Sony dealer.

1) **Diopter:** A unit to indicate the degree of convergence or divergence of a bundle of rays.

Adjusting the Lens

Flange Focal Length Adjustment

It is necessary to adjust the flange focal length (the distance from the lens flange to the plane of the image along the optical axis) in the following cases.

- When a lens is fitted for the first time
- After changing lenses
- When during zoom operations the focus does not match properly from telephoto to wide angle

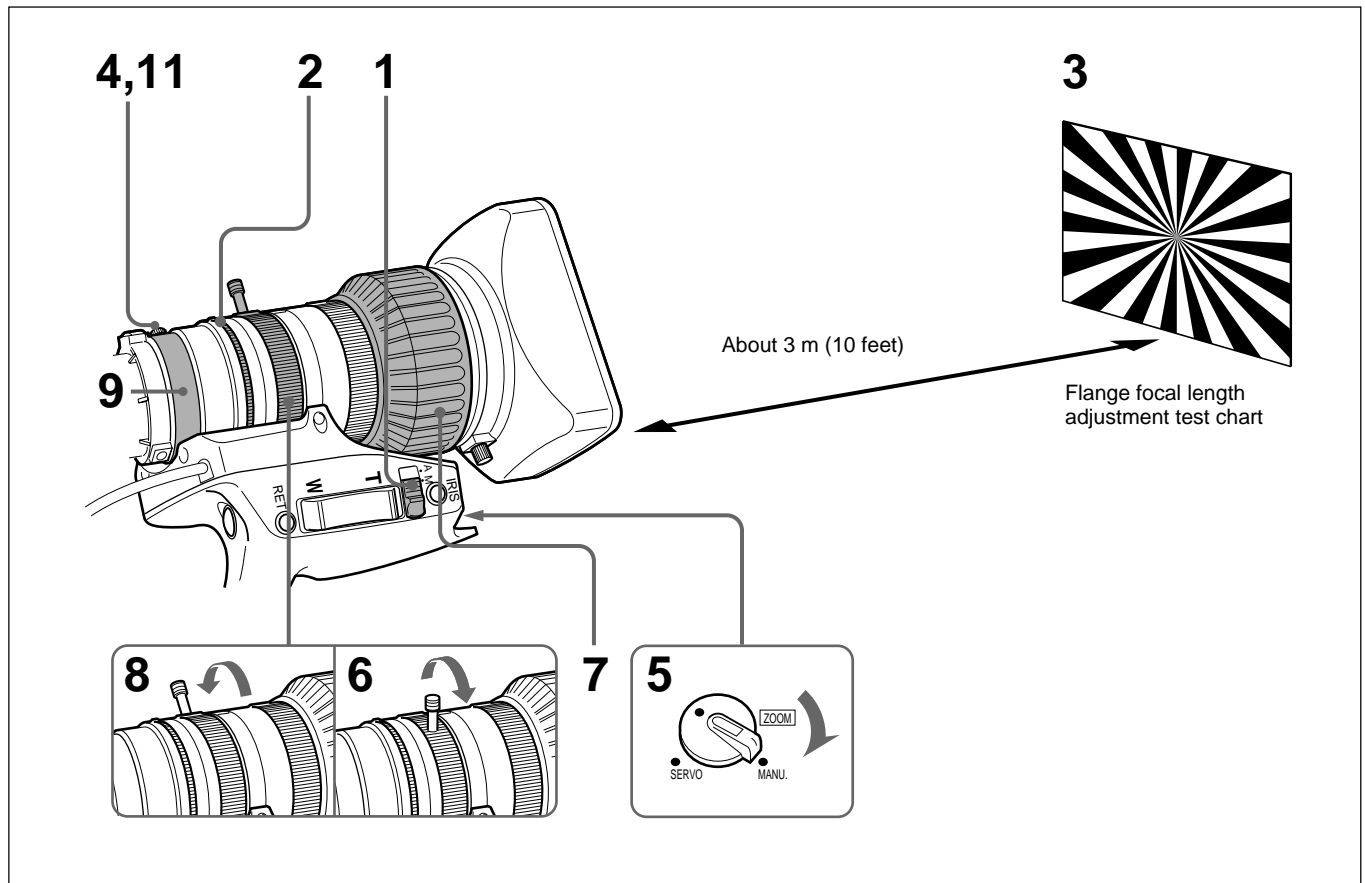

- 1** Set the iris selector to the M position.
- 2** Turn the iris ring to f/1.8 (fully open).
- 3** Place the supplied flange focal length adjustment test chart at a range of about 3 meters (10 feet), and adjust the lighting so that an appropriate video output level is obtained with the iris at f/1.8.
- 4** Loosen the F.B fixing screw.
- 5** Set the ZOOM selector to the MANU. position.
- 6** Move the manual zoom control to the telephoto position.
- 7** Turn the focusing ring so that the test chart is in focus.
- 8** Move the manual zoom control to the wide angle position.
- 9** Turn the F.B adjustment ring so that the test chart is in focus. Do not move the focusing ring.
- 10** Repeat steps 6 to 9 until the image stays in focus from telephoto to wide angle.
- 11** After adjustment, tighten the F.B fixing screw.

Adjusting the Lens

Iris Adjustments

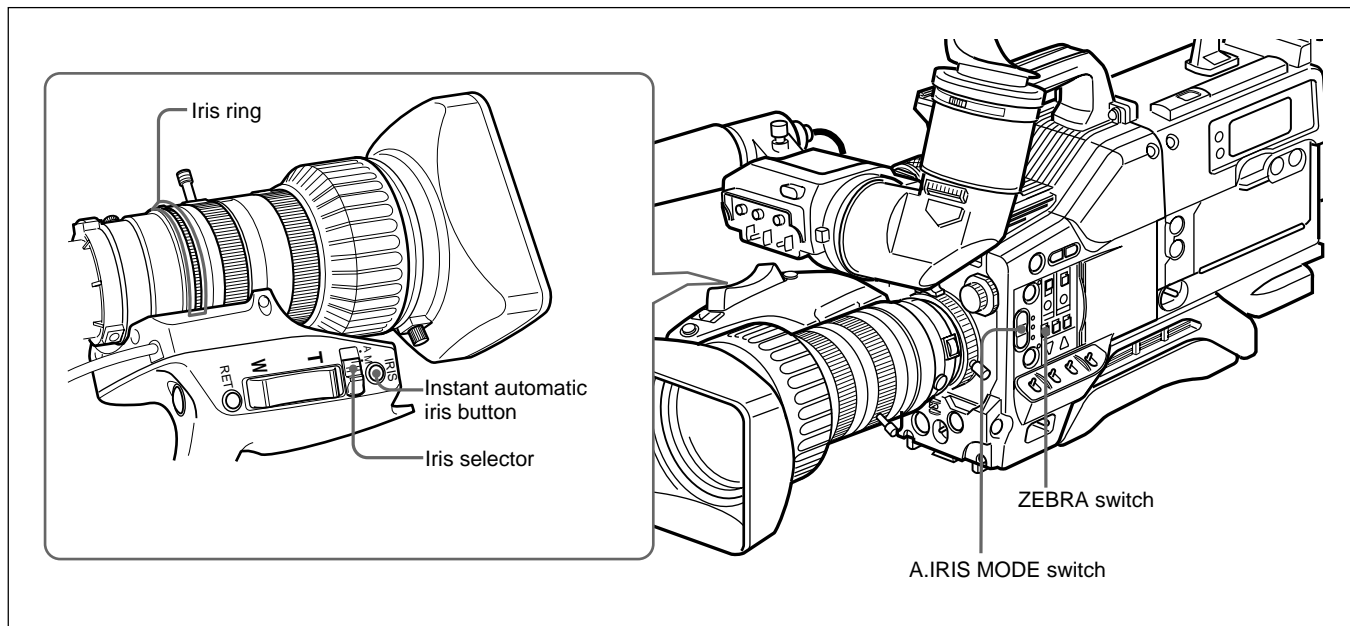

There are three ways of adjusting the iris: automatically, manually, and with the instant automatic iris adjustment function.

Iris adjustment

Adjustment method	Operation
<p>Automatic adjustment mode The iris is adjusted automatically to adapt to changes in the brightness of the subject. This is the mode for normal shooting.</p>	Set the iris selector to the A position.
<p>Manual adjustment mode Use this mode in the following cases:</p> <ul style="list-style-type: none"> • For special effects • When filming a person with a very bright sky background • When shooting a subject with extreme contrast <p>The zebra pattern can be used as a guideline for iris adjustment.</p>	Set the iris selector to the M position and turn the iris ring as required.
<p>Instant automatic adjustment function While in manual adjustment mode, this function makes a temporary automatic adjustment.</p>	With the iris selector in the M position, hold down the instant automatic iris button for as long as necessary.

To make the image lighter when shooting against the light

In the automatic iris adjustment mode, set the A.IRIS MODE switch to BACK L, turning the indicator on.

To make the image clearer when shooting a subject lit by a spotlight

In the automatic iris adjustment mode, set the A.IRIS MODE switch to SPOT L, turning the indicator on.

Using the zebra pattern in manual adjustment mode

To use the zebra pattern as a guideline for iris adjustment in manual adjustment mode, set the ZEBRA switch to the ON position.

Select the zebra pattern to be displayed in advanced menu page 4 (see page 65).

- **When the subject is a person**

Adjust the iris manually so that the zebra pattern appears on the highlights of the subject's face.

- **For other subjects**

Adjust the iris manually so that the zebra pattern appears on the most important parts of the subject.

Designating the lens

You have to designate the lens number according to the types of your lens.

If the number is not designated properly, other colors may appear on the upper and lower of the screen when shooting a white subject.

Set the number in advanced menu page 4 (page 65) according to the following table.

Product	Lens number
Fujinon: VCL-916BYA, A16X9 BRM, A12X6.8 BRM Canon: VCL-918BY, YJ18X9B KRS	1
Fujinon: A10X4.8 BEVM/BERD, A15X8 BERM/BERD, A16X9 BERM, A20X8 BEVM/BERD, A19X8.7 BERM, A19X8.7 BRM Canon: J9aX5.2B IRS/IAS, J15aX8B IRS/IAS	2
Canon: J21aX7.8B IRS/IAS, YJ18X9B IRS	3
Set up the data with Sony dealer.	4

If you use the lens that is not mentioned above, set the lens number as follows:

- When using a lens without an extender, set it to 1.
- When using a lens with an extender, set it to 2.
- When using a lens with a ratio converter, set it to 2.

You can also ask a Sony dealer more precise settings according to your lens. In this case, set it to 4.

Adjusting the Iris Sensitivity

You usually need not adjust the iris sensitivity because lenses are equipped with iris sensitivity adjustment function.

In auto iris mode, if hunting or response delay happens, adjust the iris sensitivity using the iris sensitivity trimmer.

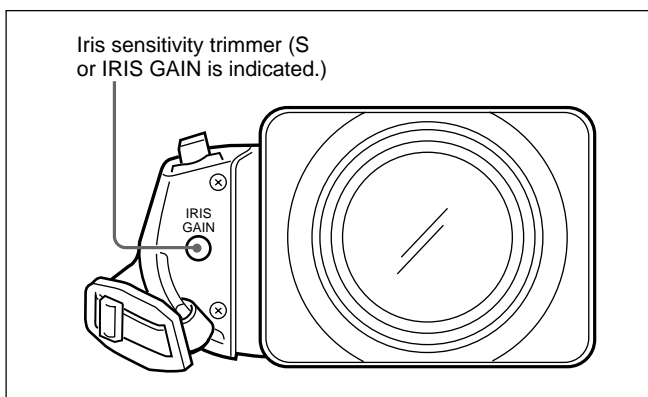

You can see the iris sensitivity trimmer when removing the gum cap on the front of the lens driving unit. Use a mini-screwdriver to turn the trimmer. If you turn it clockwise, the sensitivity increases, and if you turn it counterclockwise, the sensitivity decreases. It is recommended that you confirm the iris sensitivity after replacing the lens.

For more information, refer to the operating instructions for the lens (or consult the lens maker).

Macrophotography

Use the macro function when the subject is less than about 90 cm (3 feet) (for the VCL-918BY) from the front of the lens. It is possible to shoot close-ups down to a range of 10 mm (wide angle, $f = 9$ mm).

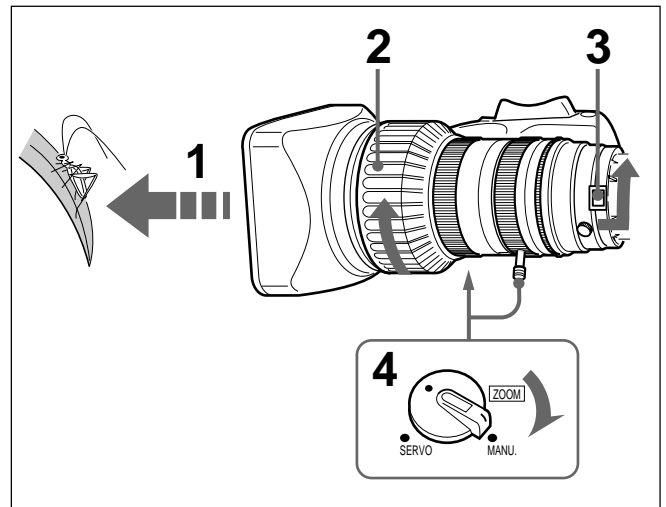

- 1 Bring the lens up to the subject so that the image is the required size.
- 2 Move the focusing ring to the closest focus position.
- 3 Slide the M button toward the rear of the camera, and turn the MACRO ring fully in the direction shown by the arrow.
- 4 Move the ZOOM selector to the MANU. position, and turn the manual zoom control to focus the image.

Ending close-up shooting

Return the MACRO ring to its original position (turn fully in the opposite direction to the arrow in the figure).

Reducing the size of the image

After completing steps 1 to 4 above, if you wish to reduce the size of the image, turn the MACRO ring back slightly, then use the manual zoom control again to focus the image.

Settings for Special Cases

Settings for special cases

Shooting conditions	Setting	Effect
The background is very bright, and the subject is too dark.	Set the A.IRIS MODE switch to BACK L, turning the indicator on.	This lightens the foreground.
The subject is under a spotlight.	Set the A.IRIS MODE switch to SPOT L, turning the indicator on.	This prevents white burn-out in highlights of faces and clothes.
The subject is completely still (e.g. when shooting documents, drawings, etc.).	Enable the EVS (Enhanced Vertical definition System) function. (See page 84.) Note Enabling the EVS function tends to increase the occurrence of aliasing problems (moiré patterns). Therefore, normally leave the function disabled.	This enhances the vertical resolution.
When you wish to give a lush effect, as when shooting a wedding or similar occasion.	Use the HI SAT file. (Access advanced menu page 10 with the SET UP switch set to FILE.)	This increases the saturation of primary colors.
Shooting under fluorescent lighting.	Use the FL file. (Access advanced menu page 10 with the SET UP switch set to FILE.)	This eliminates the blue-green cast, and restores natural hues.
When shooting bright areas mixed with dark areas (Example: A person indoors looking through a window at a bright landscape outdoors)	Set DL to ON in the advanced menu page 2 and, then set the OUTPUT/DL/DCC+ switch to CAM DL.	Prevents white breakup and color faults in bright areas.
When adjusting for skin detail or tone (Example: When shooting to hide skin details)	See “Skin Detail Correction” or “Adjusting Color in the Specified Area” (page 93).	Adjusts the skin detail or tone to a designated active area.
When you wish to give pictures a natural taste created by film camera.	Use the FILMLIKE file. (Access advanced menu page 10 with the SET UP switch set to FILE.)	The “filmlike” effect is added to the picture.
To make focusing before shooting easier.	Press the EZ FOCUS button, turning the “easy focus” function on.	This opens the iris, to make it easier to focus before beginning shooting.
To begin shooting immediately when there is no time to make adjustments.	Set the EZ MODE switch to the ON position.	This provides automatic adjustment to a set of standard values, to allow immediate shooting.

Skin Detail Correction

The DXC-D35/D35P/D35WSL/D35WSPL provides an easy push-button function that designates an active skin tone area.

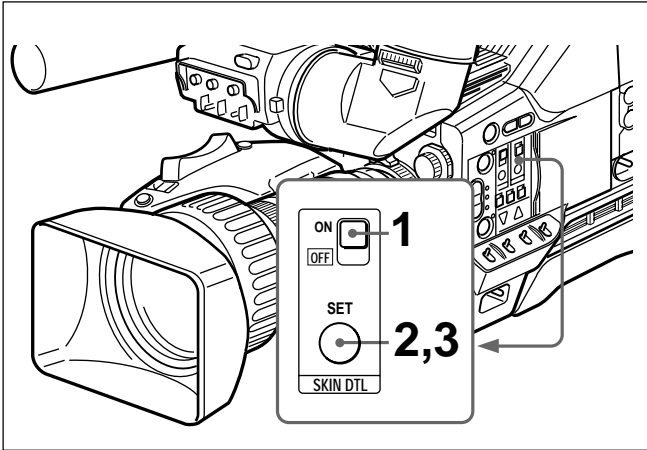

- 1 Set the SKIN DTL switch to ON.

The indication “SKIN AREA: ±0” appears in the viewfinder.

- 2 Press the SKIN DTL SET button.

This causes the area detect cursor to be shown in the viewfinder (for 10 seconds).

- 3 Place the area detect cursor on the target, then press the SKIN DTL SET button.

This designates the correction area, which is indicated by a zebra pattern, and the indication “SKIN AREA: ±0” appears again. If the area detect cursor disappears before designating the area, press the SKIN DTL SET button again to display the cursor. (Return to step 2.)

- 4 Press the UP/ON or DOWN/OFF button to change the SKIN AREA value (–99 to +99) so that the zebra pattern may be displayed in the target area. Use basic menu page 2 to set the correction level (see page 59).

You can also change color in the designated area (see the following section).

Adjusting Color in the Specified Area

You can adjust the specified color using setup files. Perform the same procedure with the skin detail correction to designate the target area.

- 1 Turn the POWER switch on with holding down the UP/ON button.
- 2 Perform steps 1 and 2 in “Changing File Settings” (page 73) and display advanced menu page 12 in the most suitable file for shooting.

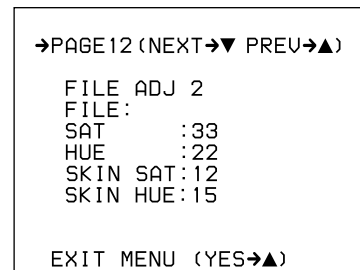

- 3 Perform the procedure for the skin detail correction to designate the area to which you apply color adjustment.

While this procedure is being performed, the menu is not displayed.

- 4 When advanced menu page 12 appears, change the value of the SKIN SAT or SKIN HUE to adjust color in the area designated in step 3.

Note

Set the SKIN DTL to 1.0 in basic menu page 2 if the skin detail correction is unnecessary.

Appendix

Important Notes on Operation

Fitting the zoom lens

It is important to fit the lens correctly, as otherwise damage may result. Be sure to refer to the section “Fitting the Lens” (See page 30).

Do not cover the unit while operating

Putting a cloth, for example, over the unit can cause excessive internal heat build-up.

Operation and storage

Avoid storing or operating the unit in the following conditions.

- In excessive heat or cold (operating temperature range: $-10\text{ }^{\circ}\text{C}$ to $+45\text{ }^{\circ}\text{C}$ ($14\text{ }^{\circ}\text{F}$ to $113\text{ }^{\circ}\text{F}$))
Remember that in summer in warm climates the temperature inside a car with the windows closed can easily exceed $50\text{ }^{\circ}\text{C}$ ($122\text{ }^{\circ}\text{F}$).
- In damp or dusty locations
- Locations where the unit may be exposed to rain
- Locations subject to violent vibration
- Close to radio or TV transmitters producing strong electromagnetic fields.

Viewfinder

- Do not leave the camera with the eyepiece pointing directly at the sun.
The eyepiece lens can concentrate the sun’s rays and melt the interior of the viewfinder.
- Do not use the viewfinder close to strong magnetic fields. This can cause picture distortion.

Shipping

Use the optional LC-421 Carrying Case for optimal shipping.

If sending the camera by truck, ship, air or other transportation service, first store it in the carrying case, then pack the carrying case in the supplied carton (or an equivalent).

Care of the unit

Remove dust and dirt from the surfaces of the lenses or optical filters using a blower.

If the body of the camera is dirty, clean it with a soft, dry cloth. In extreme cases, use a cloth steeped in a little neutral detergent, then wipe dry. Do not use organic solvents such as alcohol or thinners, as these may cause discoloration or other damage to the finish of the unit.

In the event of operating problems

If you should experience problems with the unit, contact your supplier or Sony service representative.

Important Notes on Operation

Characteristics of CCD Sensors

The following effects may appear in the image. They are characteristic of cameras using CCDs (charge-coupled devices), and do not indicate a malfunction.

Vertical smear

When shooting a very bright object, such as a light, the highlight tends to produce vertical tails. This effect is much reduced in this camera.

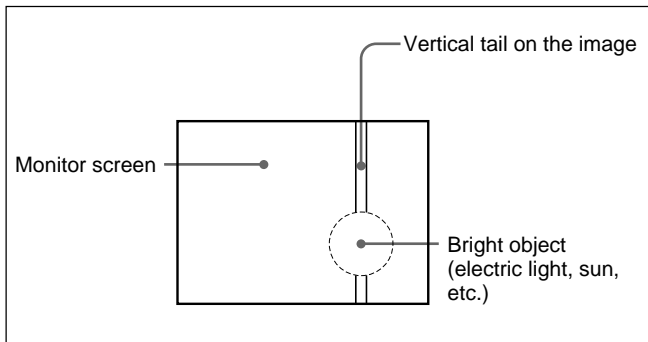

White flecks

If the camera is operated at a high temperature, white flecks may appear in the image.



Warning Indications

If a fault occurs during operation, a warning is given by the REC/TALLY and BATT indicators in the viewfinder and the tally lamp lighting or flashing, and also by warning indications on the viewfinder screen. When you are using a DSR-1/1P or PVV-3/3P, the

WARNING indicator on the VTR also lights or flashes, and warning indications appear in the display window. There is also a warning tone in the earphone.

Warning indications

Camera			VTR			Fault	VTR action	What to do
REC/TALLY indicator and tally lamp	BATT indicator	Viewfinder screen indication	WARNING indicator	Display window	Warning tone			
	—	—		RF (during recording only)	(During recording only)	The video heads are clogged, or there is some other fault in the recording system.	The VTR emits a warning tone when it detects head clogging.	Carry out head cleaning, referring to the instruction manual for the VTR. If the problem persists after cleaning the heads, disconnect the power and consult your Sony dealer.
	—	—		SERVO		The servo lock has been lost.	Recording continues, but the recording may not be satisfactory.	Disconnect the power and consult your Sony dealer. (The SERVO indication may flash momentarily when the tape transport starts, but this does not indicate a problem.)
	—	—		HUMID	(During recording) (During playback, rewind, or fast forward)	There is condensation.	Recording continues, but if the tape sticks to the drum, recording stops. Playback, rewind, or fast forward stops.	Stop the tape transport. Wait until the HUMID indication does not appear when you power the unit on.
	—	—		SLACK		The tape is not wound properly.	The operation stops. (Refer to the service manual or maintenance manual.)	Press the EJECT button to eject the cassette. Close the cassette compartment and check that the top panel has descended before powering off. Then consult your Sony dealer. (Do not attempt to insert any cassette.)
	—	—	(During recording only)	TAPE (flashing, during recording only)		The tape is near the end.	Operation continues.	Change the cassette if necessary.
	—	—		TAPE (flashing)		The tape is at the end.	Recording, playback, and fast forward all stop.	Change the cassette.
		BATT 11.0V		BATT (flashing)	(During recording)	The battery is almost exhausted.	Operation continues.	Change the battery when possible.
		BATT 10.5V		BATT (flashing)		The battery is exhausted.	Operation continues.	Change the battery.

Continuous Flashing once per second Flashing four times per second

Four beeps per second One beep per second Continuous

For the warnings appearing in the viewfinder when a VTR is connected, see the section "Viewfinder Normal Indications" (page 54).

Specifications

DXC-D35/D35P/D35WS/D35WSP Camera Head

Imaging element	Three-chip interline transfer CCD	Horizontal resolution (center)	DXC-D35/D35P: 880 TV lines DXC-D35WS/D35WSP: 850 TV lines (4:3 mode), 800 TV lines (16:9 mode)
Pixel resolution	DXC-D35: 768 (horizontal) × 494 (vertical) DXC-D35P: 752 (horizontal) × 582 (vertical) DXC-D35WS: 980 (horizontal) × 494 (vertical) DXC-D35WSP: 980 (horizontal) × 582 (vertical) mm	Minimum illumination	0.25 lux (at f/1.4, +42 dB) 0.4 lux (at f/1.8, +42 dB)
Imaging area	DXC-D35/D35P: 8.8 × 6.6 mm (² / ₃ -inch, 4:3 optical system) DXC-D35WS/D35WSP: 9.6 × 5.4 mm (² / ₃ -inch, 16:9 optical system)	Sensitivity	2000 lux (f/11.0 standard, 3200 K)
Built-in filter settings	1: 3200K 2: 5600K + ¹ / ₈ ND 3: 5600K 4: 5600K + ¹ / ₆₄ ND	Gain levels	Selectable -3 dB, 0 dB, 3 dB, 6 dB, 9 dB, 12 dB, 18 dB, 18 dB + DPR, 24 dB, 24 dB + DPR, hyper gain (30 dB + DPR or 36 dB + DPR)
Lens mount	Bayonet mount	Video output	Composite signal 1.0 Vp-p, sync negative, 75 Ω, unbalanced Y/C separate signals Y: 1.0 Vp-p, sync negative, unbalanced C: burst level 0.286 Vp-p, no sync
Signal standards	EIA standard signal (NTSC color system) (DXC-D35/D35WS) CCIR standard signal (PAL color system) (DXC-D35P/D35WSP)	Video S/N ratio	63 dB (typical) (DXC-D35/D35WS) 61 dB (typical) (DXC-D35P/D35WSP)
Scanning system	525 lines, 2:1 interlace (DXC-D35/D35WS) 625 lines, 2:1 interlace (DXC-D35P/D35WSP)	Registration	0.05% for all zones, without lens
Scanning frequencies	Horizontal: 15.734 kHz (DXC-D35/D35WS) 15.625 kHz (DXC-D35P/D35WSP) Vertical: 59.94 Hz (DXC-D35/D35WS) 50.00 Hz (DXC-D35P/D35WSP)	Input/output connectors	VIDEO OUT connector: BNC, 75 Ω, unbalanced LENS connector: 12-pin, for ² / ₃ -inch lens VF connector (front): 20-pin VF connector (left side): 8-pin REMOTE connector 1: Stereo mini-jack REMOTE connector 2: 10-pin MONITOR OUT connector: BNC, 75 Ω, unbalanced
Synchronization	Internal sync External sync, using signal input (VBS or BS) to the GEN LOCK IN connector of an optional camera adaptor or input from the GEN LOCK connector of a camera control unit to the VTR/CCU/CMA connector of an optional camera adaptor.	Power supply	12 V DC
		Power consumption	DXC-D35/D35P: 12 W (12.7 W when the DSR1/1P is connected) DXC-D35WS/WSP: 14.9 W (15.3 W when the DSR-1/1P is connected)
		Operating temperature	-10 °C to +45 °C (14 °F to 113 °F)
		Storage temperature	-20 °C to +60 °C (-4 °F to 140 °F)
		Mass	DXC-D35/D35P: 2.4 kg approx. (5 lb 4 oz) DXC-D35WS/D35WSP: 2.5 kg approx. (5 lb 8 oz)

External dimensions in millimeters (inches)

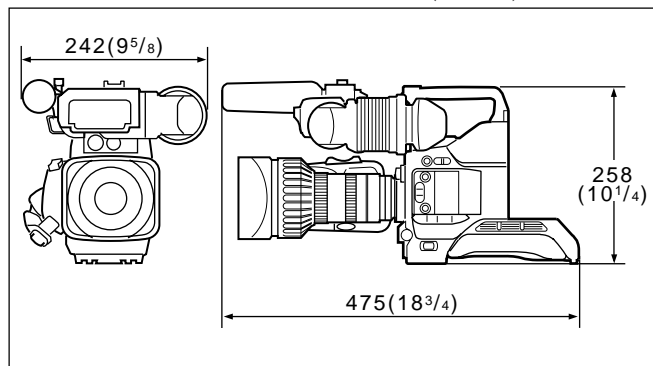

VCL-918BY Zoom Lens

Focal length	9.0 to 162 mm
Zoom	Manual or power, selectable; zoom ratio: $\times 18$
Maximum aperture	1:1.8
Iris	Manual or automatic, selectable; f/1.4 to f/16 and C (closed)
Subject area (at 0.9 m (3 feet))	Wide angle: 789 \times 592 mm (31 1/8 \times 23 3/8 inches) Telephoto: 45 \times 34 mm (1 13/16 \times 1 3/8 inches)
Focusing range	Infinity to 0.9 m
Filter attachment threads	82 mm dia., 0.75 mm pitch
Mounting	Sony 2/3-inch bayonet mount
Mass	1.3 kg approx. (2 lb 13 oz) (excluding lens hood)
External dimensions	122 \times 120 \times 219.7 mm (4 7/8 \times 4 3/4 \times 8 3/4 inches) (with lens hood, without lens grip)

DXF-801/801CE Viewfinder

Picture tube	1.5-inch monochrome
Indicators	REC/TALLY ($\times 2$), BATT, SHUTTER, GAIN UP
Resolution	600 TV lines
Power supply	12 V DC
Power consumption	2.1 W
Mass	620 g approx. (1 lb 5 oz)
Maximum external dimensions	241 (W) \times 91 (H) \times 203 (D) mm (9 1/2 \times 3 5/8 \times 8 inches)
Scan size	Switchable between 4:3 and 16:9

Supplied accessories

- RM-LG1 Remote Control Unit²⁾ (1)
- VCL-918BY Zoom Lens¹⁾ (1)
- DXF-801/801CE Viewfinder²⁾ (1)
- Microphone²⁾ (1)
- Wind screen²⁾ (1)
- VCT-U14 Tripod Adaptor²⁾ (1)
- Lens mount cap (1)
- Flange focal length adjustment test chart (1)
- Operating Instructions (1)

Design and specifications are subject to change without notice.

Related Products

There is a range of Sony products available to meet every conceivable video shooting requirement. For details, consult your Sony sales representative or supplier.

Lenses

VCL-915BYA/916BY/916BYA/918BY Zoom Lens

Camera adaptor products

- CA-325A/325AP/327/327P/511/512³⁾/512P³⁾/513/537/537P Camera Adaptor
- CMA-8A/8ACE AC Adaptor
- RM-M7G Camera Remote Control Unit

1) DXC-D35K/D35PK
2) DXC-D35K/D35L/D35WSL/D35PK/D35PL/D35WSPL

3) When connecting a CA-512/512P, remove the blank panel on the CA-512/512P.

Specifications

VTR products

DSR-1/1P Digital Videocassette Recorder
EVB-9000/9000P Videocassette Recorder
PVV-1/1P/1A/1AP/3/3P Portable Videocassette Recorder
VO-8800/8800P Portable Videocassette Recorder
BVU-150/150P Portable Videocassette Recorder
BVV-5/5PS Videocassette Recorder
BVW-50/50P Portable Videocassette Recorder
VA-5/5P/90/90P VTR Adaptor

Battery products

NP-1B/1A Battery Pack
BP-90A/L40/L60A Battery Pack
BC-1WD/1WDCE/1WB/1WBCE/410/410CE/L50/L100/L100CE Battery Charger
DC-L1/DC-L90/DC-500 Battery Case

Microphone products

ECM-670/672 Electret Condenser Microphone
C-74 Condenser Microphone
CAC-12 Microphone Holder
EC-0.5C2 Microphone Cable
EC-0.3C2 Microphone Cable

Studio equipment

CCU-M5/M5P/M5A/M5AP/M7/M7P Camera Control Unit
DXF-51 5-inch Viewfinder (monochrome)
DXF-41 4-inch Viewfinder (monochrome)
DR-100 Intercom Headset

Cables and miscellaneous

The suffix number on a cable part number indicates the length in meters: e.g. a CCZ-A2 is 2 meters long. (Approximate equivalents in feet: 2 m = 6 ft, 5 m = 16 ft, 10 m = 33 ft, 25 m = 82 ft, 50 m = 164 ft, 100 m = 328 ft)

Camera cables with Z-type 26-pin connectors
CCZ-A2/A5/A10/A25/A50/A100
Camera cables with Q-type 14-pin connectors
CCZQ-A2/A5/A10/A2AM
CCZZ-1B/1E Cable Extension Connector
Camera cables with Q-type 14-pin connectors
CCQ-2BRS/5BRS/10BRS
CCQ-10AM/25AM/50AM/100AM
CCZJ-2 Camera Cable with Z-type 26-pin connector and J-type 10-pin connector
LC-421 Carrying Case
LCR-1 Rain Cover
CAC-4 Chest Pad
LC-DS300SFT Soft Case

Chart of Optional Components and Accessories

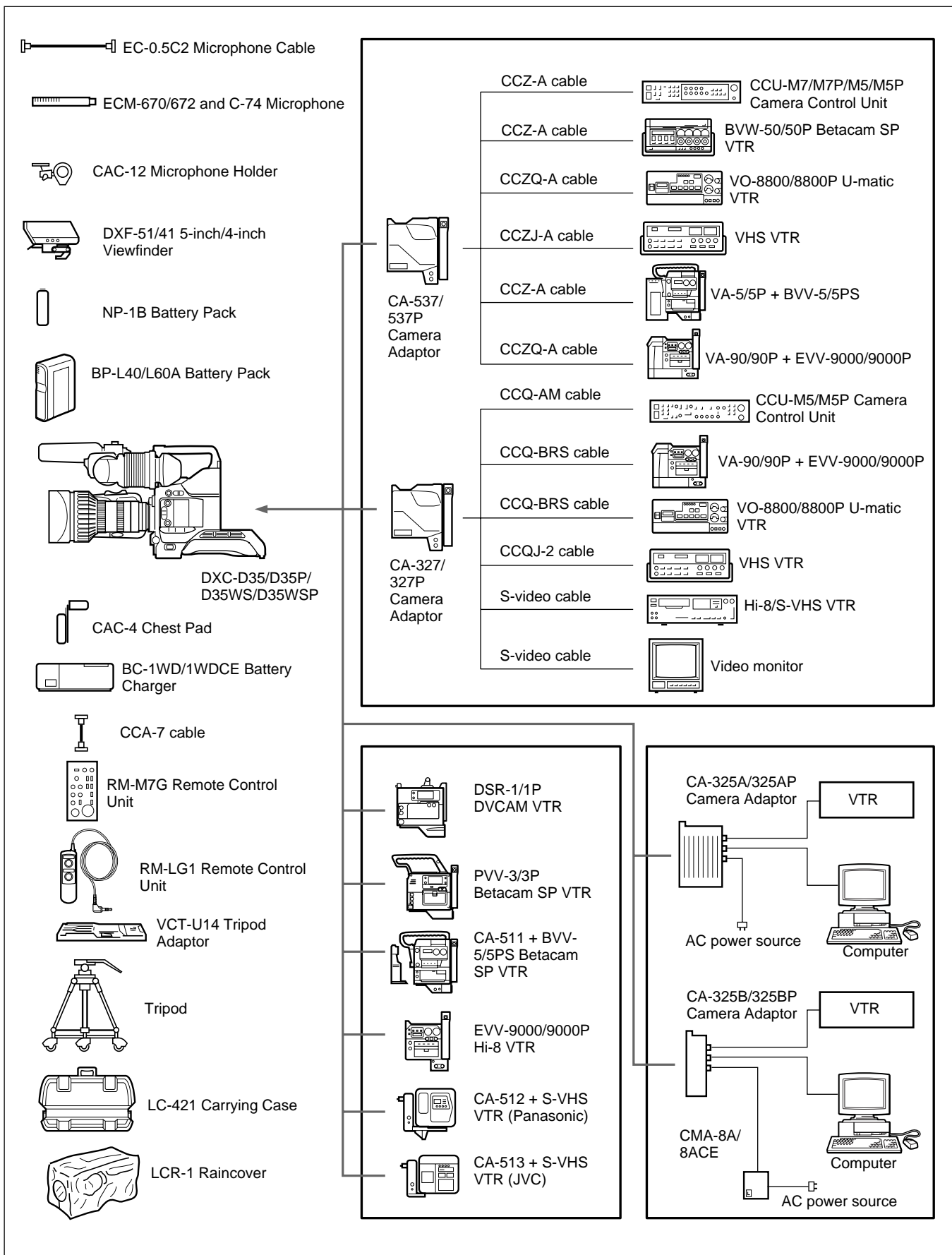

What Is ClipLink?

The ClipLink™ function greatly improves the efficiency of the video production process as a whole by recording various editing-related data on tape when shooting. As such, ClipLink is a revolutionary function that transcends the conventional separation of shooting and editing.

Note

When an external equipment, such as VCR, is connected to the DV OUT connector, the ClipLink function will not work.

How ClipLink Changes Video Production Techniques

The following describes various ways in which ClipLink¹⁾ video production differs from conventional video production.

Recording of ClipLink log data lightens the shooting workload

When you start shooting a scene, ClipLink log data such as the scene number and time code data are automatically recorded into the cassette memory. This eliminates the need for a conventional “shot list” compiled by someone using a stopwatch, clipboard and pencil. You can also designate unwanted scenes as “NG” (no good) and automatically skip all “NG” scenes when editing.

Recorded Index Pictures drastically cut editing time

The ClipLink function also features Index Pictures a time-saving tool for rough editing. Each Index Picture is a compressed image taken from the start of each scene, which is recorded onto the tape as a still picture. When editing, begin by transferring only the Index Pictures and the ClipLink log data to the EditStation’s hard disk. You can also transfer OK scenes only (“NG” scenes are skipped).

Next, begin rough editing by viewing the Index Pictures on the EditStation’s GUI display and rearranging them as you wish. This eliminates the difficult work of matching up a handwritten shot list with recorded scenes. After you have completed this rough editing, you can then transfer only the recordings needed for your video program.

High-speed transfer of recordings

It is also possible to transfer the editing material itself between the DSR-85/85P and ES-7 at four times normal speed. In other words, the transfer can be carried out in one fourth of the real time duration. It is of course possible to carry out a transfer at four times normal speed when backing up video and audio data recorded on the disk drive to the DSR-85/85P, or in the opposite direction when loading data backed up on the DSR-85/85P to the disk drive. Thus the time required is much shorter than with conventional equipment (for which, for example, transferring a 40-minute segment of video takes 40 minutes).

Note

When using a tape recorded by a DVCAM camcorder to transfer digital (video/audio/time code) signals at four times normal speed from the DSR-85/85P Digital Videocassette Recorder to the ES-7 EditStation for editing purposes, there must be about at least 40 seconds of recording on the tape before the IN point. To perform editing without problems, it is recommended **that you pre-record at least 40 seconds of color bar signals at the beginning of the tape.**

1) The ClipLink system is a video production system which uses the cassette memory function.

ClipLink Operation Flow

The following is a detailed description of how to use the ClipLink function during the video production process.

Example System Configuration

The following illustration shows the optimum system configuration for using the ClipLink function. ClipLink operation is possible even with a system containing existing analog equipment. However, note that a part of functions are disabled.

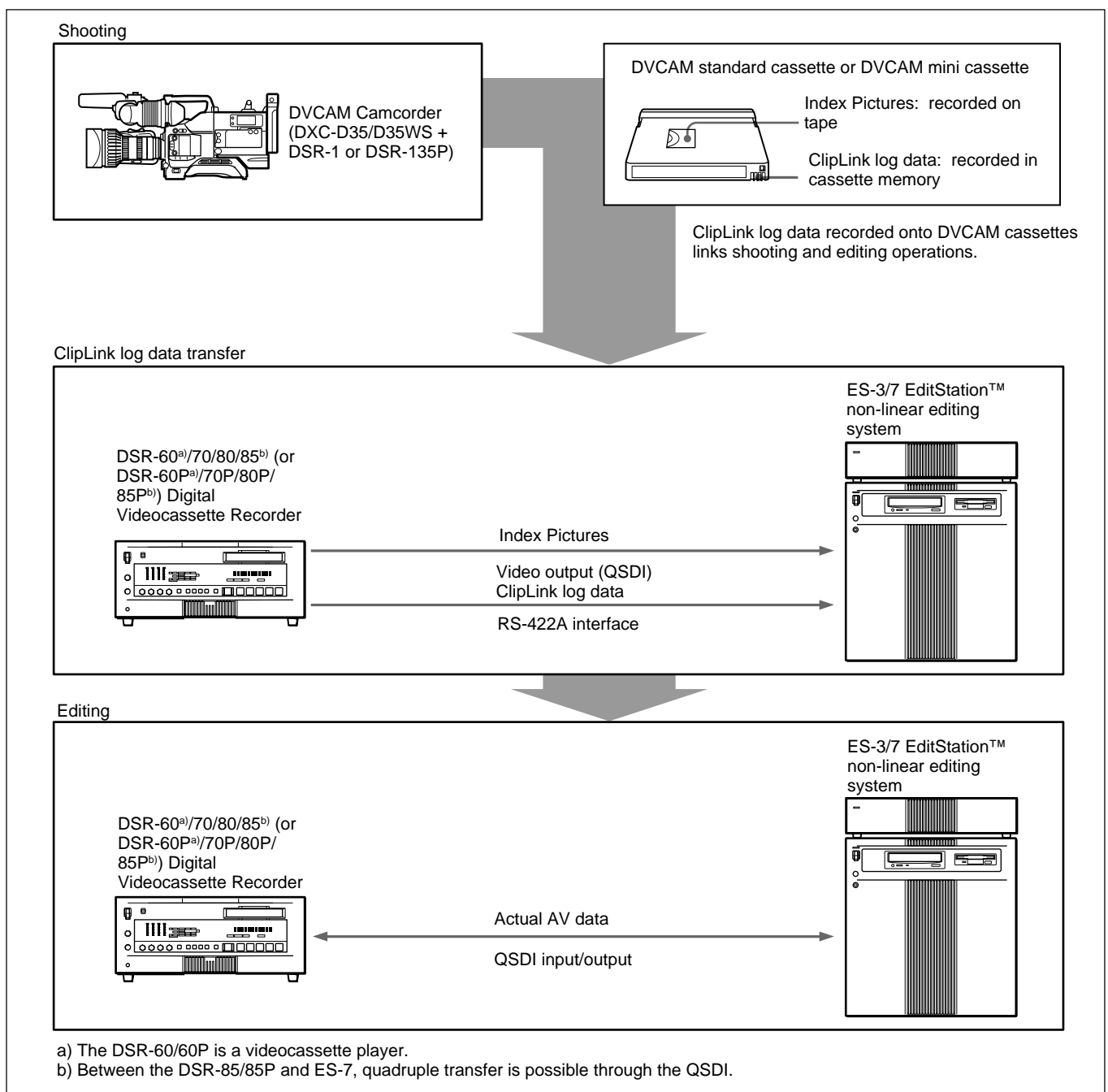

ClipLink Operation Flow

Data Generated When Shooting

The following describes the kinds of data that is generated when using the ClipLink function.

Index Pictures

When shooting, a single-frame image from the Mark IN point at the start of each scene is recorded as a still picture into the DSR-1/1P's internal memory. These images are called "Index Pictures". When you finish shooting, the Index Pictures from all scenes are recorded onto the tape after the last scene.

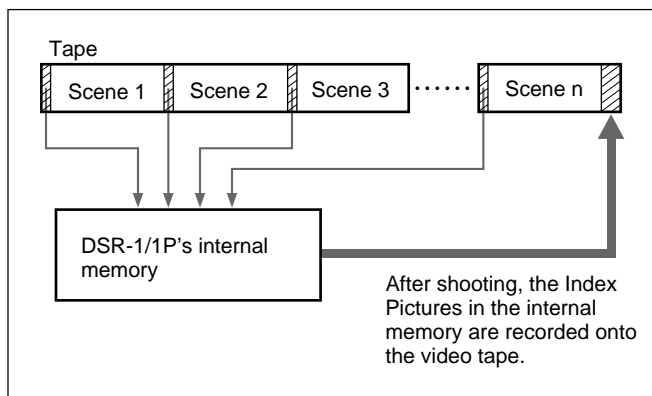

Up to 32 Index Pictures can be recorded onto the tape space normally occupied by one frame, as shown below.

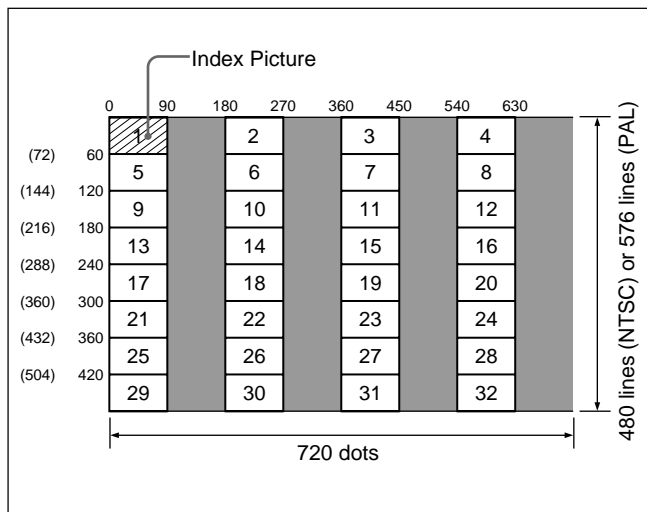

Seven frame spaces are reserved at the end of the last scene as a recording area for Index Pictures. (A cassette with 16 Kbits of cassette memory can record up to 198 Index Pictures, and a cassette with 4 Kbits of cassette memory can record up to 45 Index Pictures.)

ClipLink log data

ClipLink log data can be recorded automatically or manually into the cassette memory for use as a

convenient alternative to the conventional "shot list". ClipLink log data includes the following items.

ClipLink log data	Description
Reel number (cassette number)	Data (maximum length: 8 digits) consisting of alphanumeric characters and/or symbols (This is left blank at shipping.)
Scene number	A three-digit number from 001 to 198 (starts at 001 and is automatically incremented with each scene).
Take number	This cannot be changed (set to "1" at shipping).
OK/NG	Indicates the OK/NG status of a particular scene. (In the OK case, nothing is recorded.)
Mark IN/OUT point time codes	These are the time codes that indicate the Mark IN and Mark OUT points for each scene (HH:MM:SS). These time codes are recorded when the camcorder has been set to Mark mode. The frame digit is incremented at each Mark IN point and is decremented at each Mark OUT point. (For details, see "Time codes recorded for Mark IN/OUT points" on page 106)
Cue point time code	This is the time code that indicates the cue points (valid up to the frame digit). This time code is recorded when the camcorder has been set to Cue mode. When in this mode, the time codes at the start and end of a recording (the Rec IN and Rec OUT time codes) are automatically recorded as Mark IN/OUT points.

How to record ClipLink log data

The following describes how to record the various ClipLink log data items.

OK/NG status

To designate a scene as “NG”, press the NG button on the camcorder while shooting the scene or at any time before you begin shooting the next scene.

All scenes that do not receive an “NG” designation are recorded as “OK” scenes.

(When you exit the VCR recording mode, changing the OK/NG status is no longer possible.)

Mark IN/OUT points time codes

This data is especially useful when shooting a video program for which a scenario has been created.

Set the camcorder to Mark mode before you start shooting. While shooting, each time you press the camcorder’s TAKE button, Mark IN and Mark OUT time codes are recorded alternately.

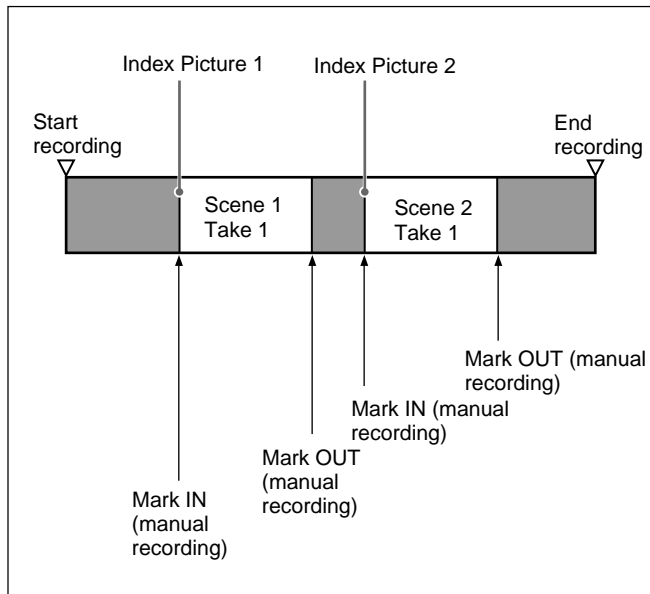

Cue point time codes

This type of data is especially useful when shooting scenes that may contain unexpected events, such as when shooting for sports coverage or documentaries. Set the camcorder to Cue mode before you start to record. While recording, each time you press the camera’s TAKE button, the current time code is recorded as a cue point time code.

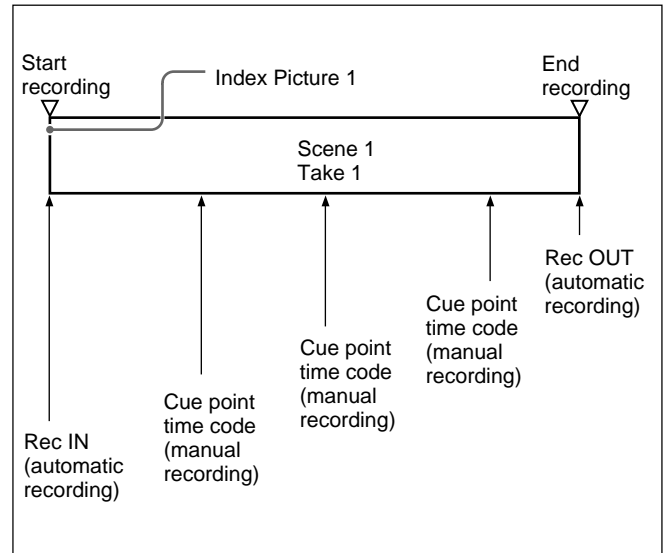

ClipLink Operation Flow

Time codes recorded for Mark IN/OUT points

There is a gap between actual time codes and Mark IN/OUT time codes recorded in the cassette memory, as shown in the figure below. The frame digit is incremented at each Mark IN point and is decremented at each Mark OUT point.

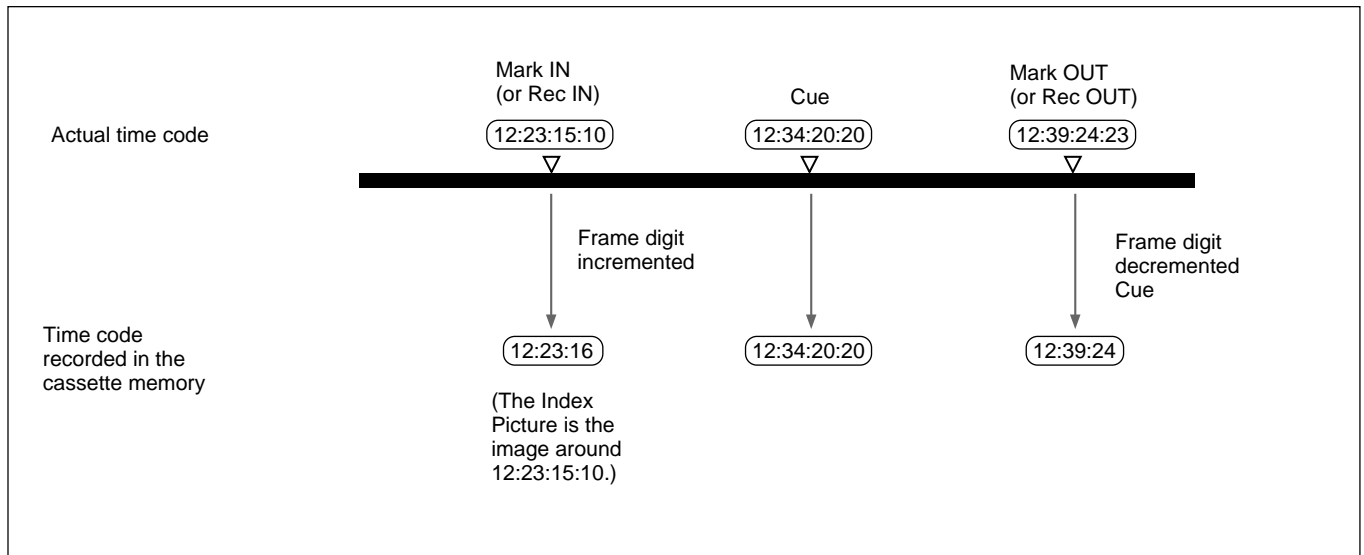

Recording capacity for Mark IN/OUT time codes and Cue point time codes

When in Mark mode, up to 198 pairs of Mark IN and Mark OUT points can be recorded (if using a cassette with 16 Kbits of cassette memory).

When in Cue mode, up to 396 time codes points (including all cue point time codes and all Mark (Rec) IN and Mark (Rec) OUT time codes) can be recorded (if using a cassette with 16 Kbits of cassette memory).

