



719B

**70 CM BROADBAND BOOMER
SSB/CW/FM YAGI
430-450 MHz**



951454 (4/95)

TA5FA

WARNING

THIS ANTENNA IS AN ELECTRICAL CONDUCTOR. CONTACT WITH POWER LINES CAN RESULT IN DEATH, OR SERIOUS INJURY. DO NOT INSTALL THIS ANTENNA WHERE THERE IS ANY POSSIBILITY OF CONTACT WITH OR HIGH VOLTAGE ARC-OVER FROM POWER CABLES OR SERVICE DROPS TO BUILDINGS. THE ANTENNA, SUPPORTING MAST AND/OR TOWER MUST NOT BE CLOSE TO ANY POWER LINES DURING INSTALLATION, REMOVAL OR IN THE EVENT PART OF THE SYSTEM SHOULD ACCIDENTALLY FALL. FOLLOW THE GUIDELINES FOR ANTENNA INSTALLATIONS RECOMMENDED BY THE U.S. CONSUMER PRODUCT SAFETY COMMISSION AND LISTED IN THE ENCLOSED PAMPHLET.

Your Cushcraft 719B Boomer antenna is designed and manufactured to give trouble free service. This antenna will perform as specified if the instructions and suggestions in this manual are followed and care is used in the assembly and installation. When checking the components received in your antenna package use the parts listed beside each diagram. There is a master parts list on page 2. If you are unable to locate any tube or component, check the inside of all tubing. **IMPORTANT:** Save the weight label from the outside of the carton. Each antenna is weighed at the factory to verify the parts count. If you claim a missing part, you will be asked for the weight verification label.

PLANNING

Plan your installation carefully. If you use volunteer helpers be sure that they are qualified to assist you. Make certain that everyone involved understands that you are the boss and that they must follow your instructions. If you have any doubts at all, employ a professional antenna installation company to install your antenna.

LOCATION

Location of the antenna is very important. Surrounding objects such as trees, power lines, other antennas, etc. will seriously reduce efficiency. To minimize the effects of surrounding objects, mount the antenna as high and in the clear as possible. If metal guy wires are used, they should be broken with strain insulators. **EXTREME CARE MUST BE USED FOR YOUR SAFETY. YOU MUST INSURE THAT WHILE THE 719B IS IN OPERATION NEITHER PEOPLE OR PETS CAN COME IN CONTACT WITH ANY PORTION OF YOUR ANTENNA. DEADLY VOLTAGES AND CURRENTS MAY EXIST. ALSO, SINCE THE EFFECTS OF EXPOSURE TO RF FIELDS ARE NOT FULLY UNDERSTOOD, LONG TERM EXPOSURE TO INTENSE RF FIELDS IS NOT RECOMMENDED. THERE IS A WARNING STICKER WHICH MUST BE ATTACHED TO THE BOOM AS SHOWN IN FIGURE E.**

MOUNTING

The mast mount bracket will accommodate up to a 2" (5.1 cm) mast. A 1-1/2" OD (3.8 cm) or larger heavy wall tubing mast should be used. A good heavy duty antenna rotator will provide the best service and longest life. Often it is desirable to mount several antennas on one mast. To keep possible interaction to a minimum, place your antennas as far apart as you can. The 719B provides excellent gain, clean pattern and low VSWR across the entire 70 centimeter band. It can be mounted either horizontally or vertically.

VERTICAL (FM): If you plan to mount the 719B for vertical polarization, best results can be obtained by mounting the antenna at the top of the mast. Note that element E9 is 2" (5.1 cm) from the edge of the mast mounting plate as shown in Figure D. *Install the 719B with the elements on the side of the mast opposite from the mounting plate.* See page 6 for suggested dual and quad array configurations.

HORIZONTAL (CW/SSB): Mount your 719B horizontally and as high as possible, with the boom-to-mast plate between elements E9 and E10 as shown in figure D. See page 6 for a suggested dual array and quad configurations.

SYSTEM GROUNDING

Direct grounding of the antenna, mast and tower is very important. This serves as protection from lightning strikes and static buildup, and from high voltage which is present in the radio equipment connected to the antenna. A good electrical connection should be made to one or more ground rods (or other extensive ground system) directly at the base of the tower or mast, using at least #10AWG ground wire and non-corrosive hardware. For details and safety standards, consult the National Electrical Code. You should also use a coaxial lightning arrester. Cushcraft offers several different models, such as LAC-1, LAC-2 and the LAC-4 series.

ASSEMBLY

Assemble your antenna by following the directions and illustrations in steps 1 through 6. After the antenna is completely assembled, verify dimensions and element spacings for accuracy. Then, return to the section below for final tuning.

TUNING PROCEDURE

The 719B does not require tuning after assembly. You may check the VSWR in order to confirm assembly was done properly. The easiest place to check the antenna is likely to be in its final mounting configuration. Orient the antenna such that it is pointing straight up. The back of the antenna should be at least 2 feet (.6 m) off the ground.

Run the coax cable from your transmitter to the area in which the antenna is to be tested. The length of this cable or your feedline is not critical. Connect a good quality VSWR bridge to the end of this cable. Connect a short length of cable [10 ft. (305 cm) or less] from the VSWR bridge to the antenna under test. Set the transmitter to your center operating frequency and measure the VSWR while taking care not to effect the measurement with your body. A VSWR of 2:1 or less is satisfactory and will not degrade the performance. If the VSWR is greater than 2:1, check all dimensions and connectors.

MASTER PARTS LIST

KEY	P/N	DESCRIPTION	QTY	KEY	P/N	DESCRIPTION	QTY
11	010011	8-32 stainless steel hex nut	23	FD		Folded dipole	1
26	190026	7/8" (2.2 cm) formed aluminum bracket	19	E1		13-3/4" (34.9 cm) aluminum rod	1
28	190028	Aluminum half washer	18	E2		12-11/16" (32.2 cm) aluminum rod	1
38	050038	1" (2.5 cm) black plastic cap	2	E3		12-3/8" (31.4 cm) aluminum rod	1
41	011941	#8 split lock washer	23	E4		12-1/8" (30.8 cm) aluminum rod	1
70	190070	4" x 6" (10.2 x 15.2 cm) formed mounting plate	1	E5		11-15/16" (30.3 cm) aluminum rod	1
84	010084	1/4" (.64 cm) stainless steel lock washer	4	E6		11-7/8" (30.2 cm) aluminum rod	1
85	010085	1/4" (.64 cm) stainless steel hex nut	4	E7		11-5/8" (29.5 cm) aluminum rod	1
104	010104	1/4" (.64 cm) stainless steel flat washer	4	E8		11-5/8" (29.5 cm) aluminum rod	1
116	240116	Silicone package	1	E9		11-1/2" (29.2 cm) aluminum rod	1
118	010118	5/16" (.79 cm) stainless steel hex nut	4	E10		11-7-16" (29 cm) aluminum rod	1
119	010119	5/16" (.79 cm) stainless steel lock washer	4	E11		11-5/16" (28.7 cm) aluminum rod	1
120	010120	8-32 x 2" (5.1 cm) stainless steel machine screw	8	E12		11-1/4" (28.6 cm) aluminum rod	1
123	010123	1-1/2" (3.8 cm) stainless steel machine screw	2	E13		11-1/4" (28.6 cm) aluminum rod	1
231	010231	8-32 x 1-3/4" (4.5 cm) stainless steel machine screw	11	E14		11-3/16" (28.4 cm) aluminum rod	1
326	290326	Danger label	1	E15		11-3/16" (28.4 cm) aluminum rod	1
401	010401	1-1/2" x 3" (3.8 x 7.6 cm) stainless steel U-bolt	2	E16		11-3/16" (28.4 cm) aluminum rod	1
404	010404	2-1/2" x 3" (5.5 x 7.6 cm) stainless steel U-bolt	2	E17		11" (27.9 cm) aluminum rod	1
411	030411	1-3/8" (3.5 cm) stainless steel worm clamp	2	E18		10-3/8" (27.9 cm) aluminum rod	1
BA		1" x 36" (2.5 x 91.4 cm) aluminum tube	1	UM4N		UltraMatch	1
BB		1-1/8" x 72" (2.9 x 182.9 cm) aluminum tube	1				
BC		1" x 64-1/2" (2.5 x 163.8 cm) aluminum tube	1				

#1 - ASSEMBLE BOOM

Assemble the boom as shown below. Slide worm clamps (411) over both ends of tube BB. Insert the end of tube BA into the end of tube BB until the first set of holes are aligned. Permanently install screw (123), washer (41) and nut (11). Insert end of tube BC into tube BB and align the first set of drilled holes. Temporarily pin using hardware 120, 41, and 11. This pin will be removed later for element mounting. Tighten all worm clamps and push on end caps (38).

KEY	P/N	DESC.	SIZE	QTY
BA		ALUM TUBING	1" x 36" (2.5 x 91.4 cm)	1
BB		ALUM TUBING	1-1/8" x 72" (2.9 x 182.9 cm)	1
BC		ALUM TUBING	1" x 64-1/2" (2.5 x 163.8 cm)	1
11	010011	SS HEX NUT	8-32	2
38	050038	PLASTIC CAP	1" (2.5 cm)	2
41	011941	SS LOCK WASHER	#8	2
120	010120	SS MACHINE SCREW	8-32 x 2"	1
123	010123	SS SCREW	8-32 x 1-1/2" (3.8 cm)	1
411	030411	SS WORM CLAMP	1-3/8" (3.5 cm)	2

FIGURE A

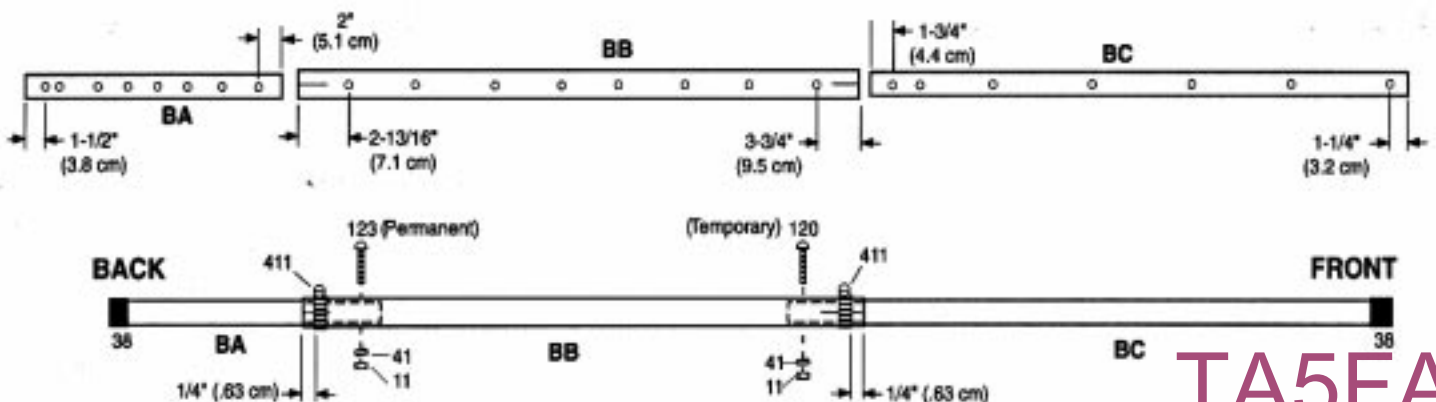

TA5FA

#2 - ASSEMBLE T-MATCH

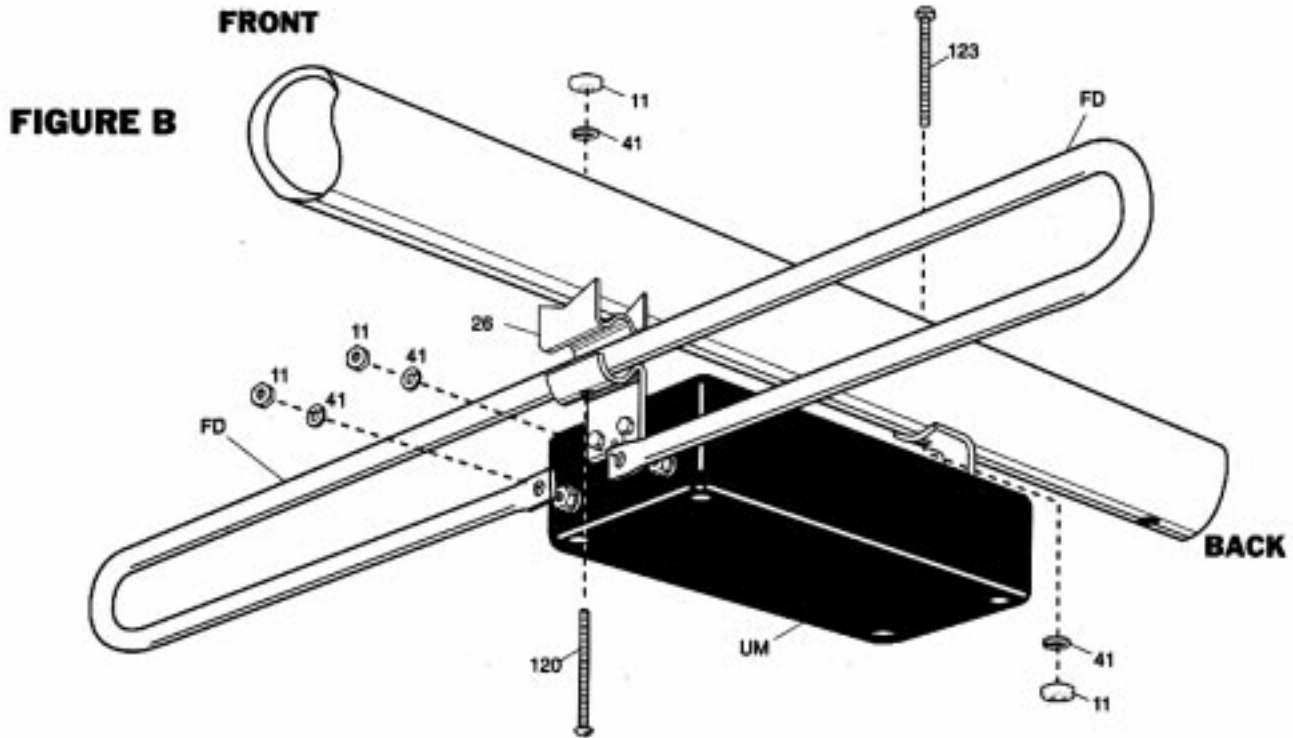

KEY	P/N	DISPLAY	DESC	SIZE	QTY
FD			FOLDED DIPOLE		1
UM4N			UltraMatch BALLUN		1
11	010011		SS HEX NUT	8-32	4
26	190026		ALUM BRACKET	7/8" (2.2 cm)	1
41	011941		SS LOCK WASHER	#8	4
120	010120		SS MACHINE SCREW	8-32 x 2" (5.1 cm)	1
123	010123		SS MACHINE SCREW	8-32 x 1-1/2 (3.81)	1

Locate the second hole in from the end of tube BA. Note the location of UM4N in figure B and D. Attach folded dipole to UM4N with washer (41) and nut (11). Secure dipole assembly to boom with machine screw (120), bracket (26), washer (41) and nut (11). Attach back bracket of UM4N to boom using the hole provided with screw (123), washer (41) and nut (11). Tighten all hardware.

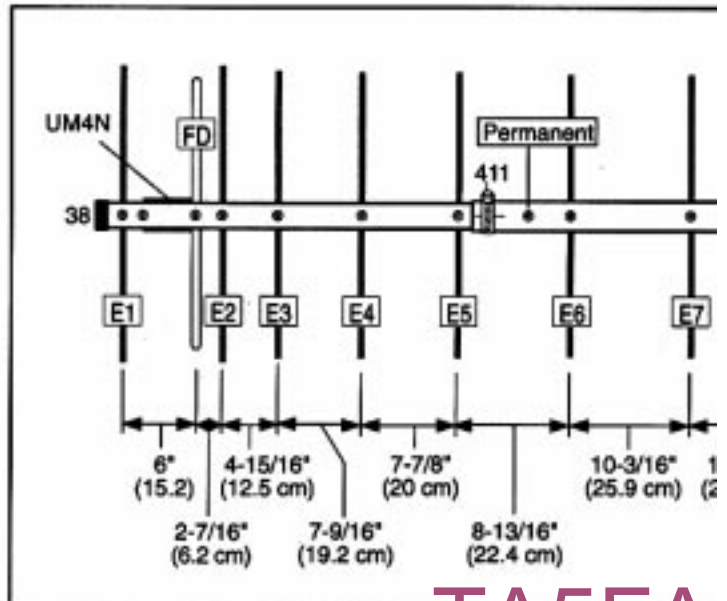

#3 - MOUNT ELEMENTS

The element lengths are given in Table 1. Using Figure D for position, attach elements using hardware as shown in Figure C. Note that screws (231) are used to attach elements to booms BA and BC. Element lengths within 1/16" (.16 cm) of stated length are acceptable. Check all elements again to assure that they are in the correct position and tighten all hardware.







KEY	P/N	DISPLAY	DESC	SIZE	QTY
11	010011		SS HEX NUT	8-32	17
26	190026		ALUMINUM BRACKET	7/8" (2.2 cm)	18
28	190028		ALUM HALF WASHER		18
41	010041		SS SPLIT WASHER	#8	17
120	010120		SS MACHINE SCREW	8-32 x 2" (5.1 cm)	6
231	010231		SS MACHINE SCREW	8-32 x 1-3/4" (4.4 cm)	11

FIGURE C



**TABLE A
(Element Lengths)**

E1	13-3/4" (34.9 cm)	E10	11-7-16" (29.0 cm)
E2	12-11/16" (32.2 cm)	E11	11-5-16" (28.7 cm)
E3	12-3/8" (31.4 cm)	E12	11-1/4" (28.6 cm)
E4	12-1/8" (30.8 cm)	E13	11-1/4" (28.6 cm)
E5	11-15/16" (30.3 cm)	E14	11-3/16" (28.4 cm)
E6	11-7/8" (30.2 cm)	E15	11-3/16" (28.4 cm)
E7	11-5/8" (29.5 cm)	E16	11-3/16" (28.4 cm)
E8	11-5/8" (29.5 cm)	E17	11" (27.9 cm)
E9	11-1/2" (29.2 cm)	E18	10-3/8" (26.4 cm)

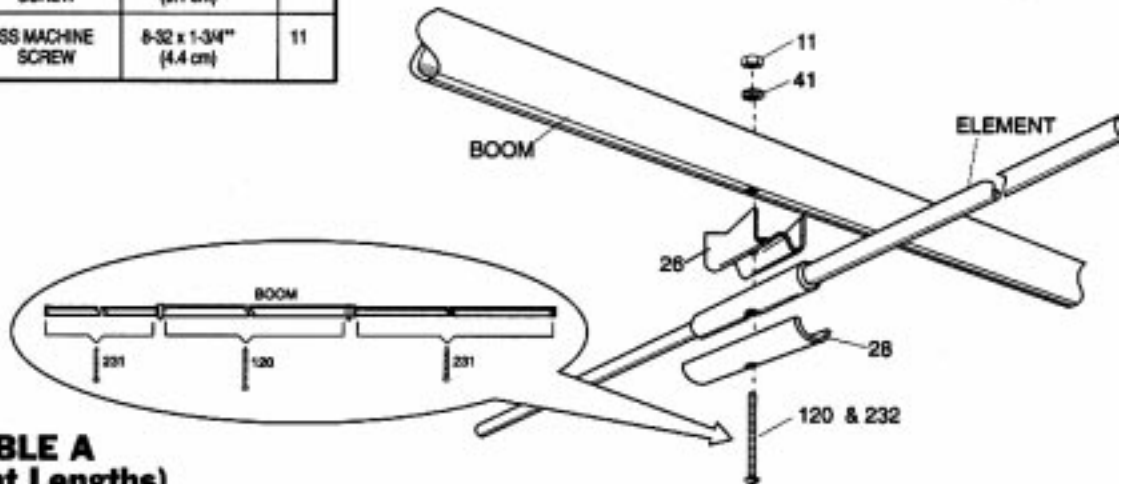
FIGURE D

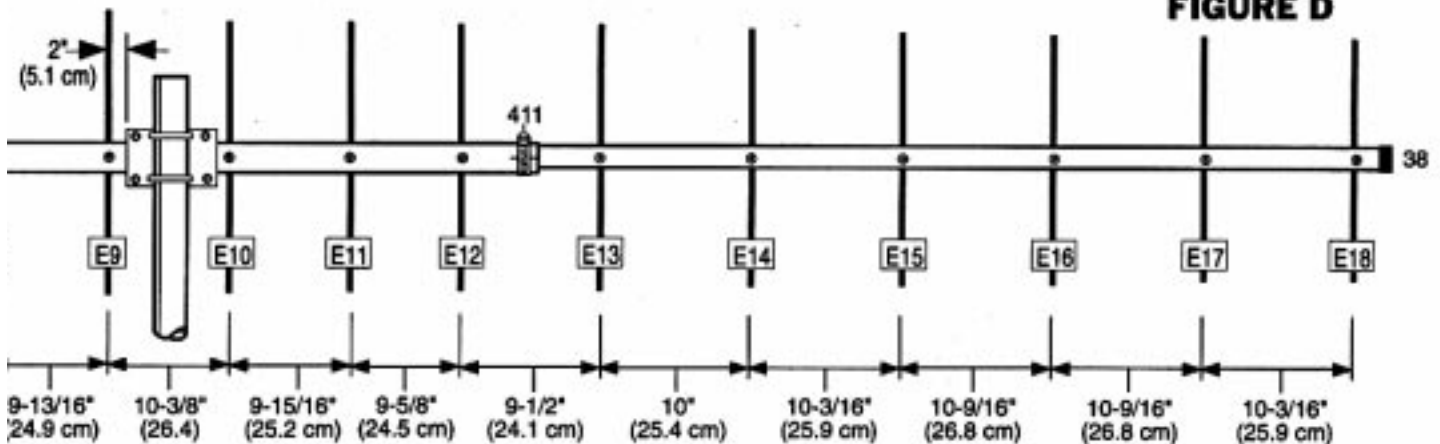

#4 - ASSEMBLE BOOM TO MAST MOUNT

Assemble and mount the boom to mast clamp bracket (70) between elements 10 and 11 with the U-bolts 401 as shown in figure E. Secure with flat washer (104), lock washer (84) and nut (85) in that order. Note that the rear of the mast clamp must be 2 inches (5 cm) from element 10 as shown on figure D. You are now ready to mount the antenna to your mast using the U-bolts 404. Secure with lock washers (119) and nut (118) in that order. Affix the warning label (326) to the boom as shown in figure E.

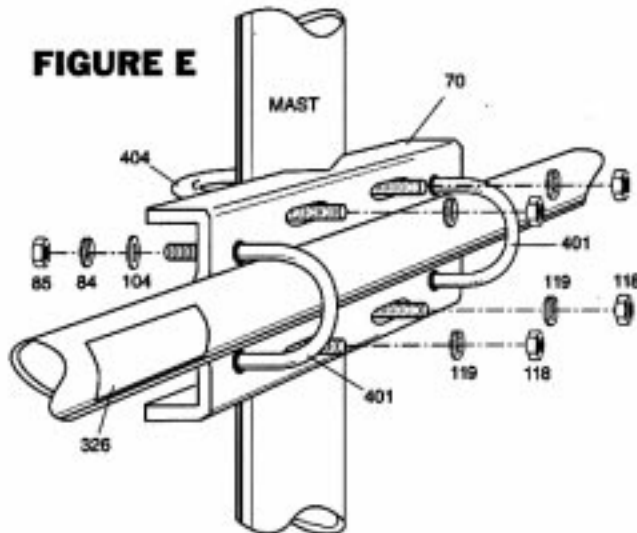

KEY	P/N	DISPLAY	DESC	SIZE	QTY
84	010084		SS LOCK WASHER	1/4" (.64 cm)	4
85	010085		SS HEX NUT	1/4" (.64 cm)	4
104	010104		SS FLAT WASHER	1/4" (.64 cm)	4
118	010118		SS HEX NUT	5/16" (.79 cm)	4
119	010119		SS LOCK WASHER	5/16" (.79 cm)	4
401	010401		SS U-BOLT	1 1/2" x 3" (3.8 x 7.6 cm)	2
404	010404		SS U-BOLT	2 1/2" x 3" (5.5 x 7.6 cm)	2
70	190070		MOUNTING PLATE	4" x 6" (10.2 x 15.2 cm)	1
326	290326		DANGER LABEL		1

#5 - CONNECTOR ASSEMBLY

KEY	P/N	DISPLAY	DESC	SIZE	QTY
116	240116		SILICONE PACKAGE		1

The antenna is designed for use with 50 Ohm coaxial cable terminated with a male N-connector. Any length of feedline can be used with your 719B. The shortest length of cable will have the least loss. Apply silicone (116) to the threaded portion of the female N-connector located on the UM4N. Do not coat the center pins of either of the N-connectors. Attach and tape the feedline in place as shown in Figure G. Before proceeding to the next section, return to the "Tuning" section on page 1 for instruction on how to test your new 719B.

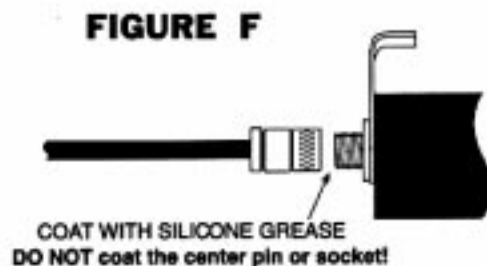

#6 - FEEDLINE ATTACHMENT

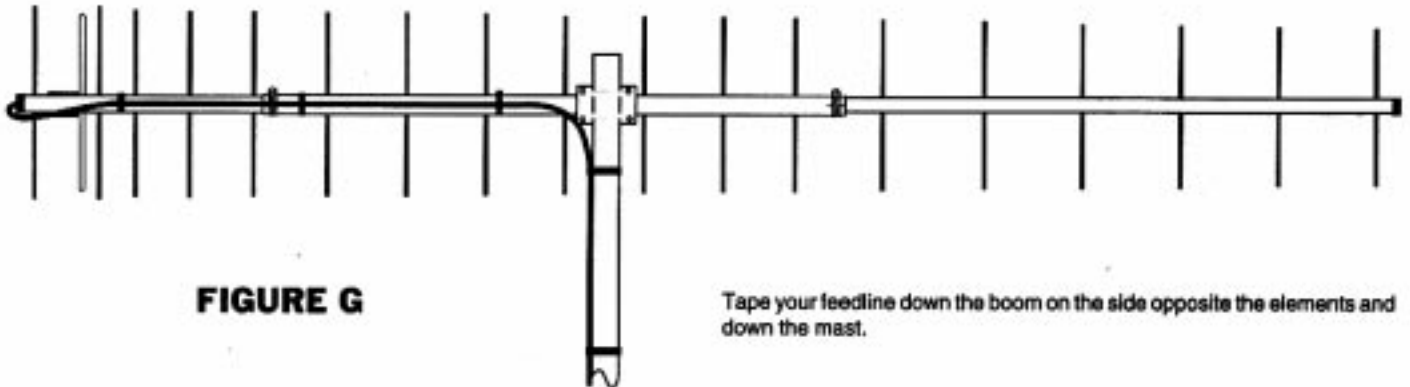

FIGURE G

Tape your feedline down the boom on the side opposite the elements and down the mast.

STACKING THE 719B

Boomers may be stacked in arrays of two or four 719B antennas for improved radiation patterns and increased gain. They may be mounted for either horizontal or vertical polarization. When stacking two vertically polarized 719B's use the 38B2VPK stacking kit, figure H. When stacking four vertically polarized 719B's use two 38BVPK and one 44-SK, figure I. When stacking two horizontally polarized 719B's use the 44-SK stacking kit figure J.

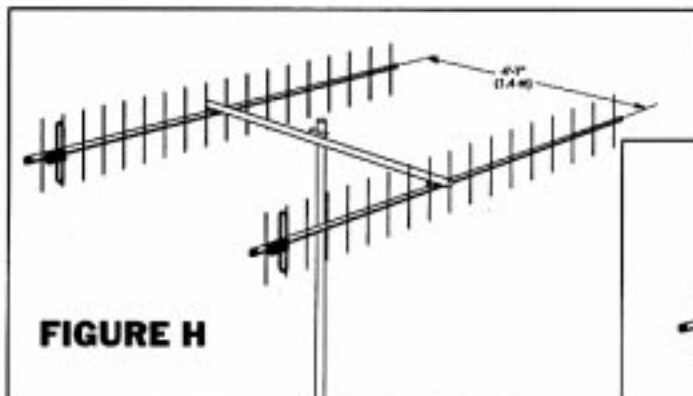

FIGURE H

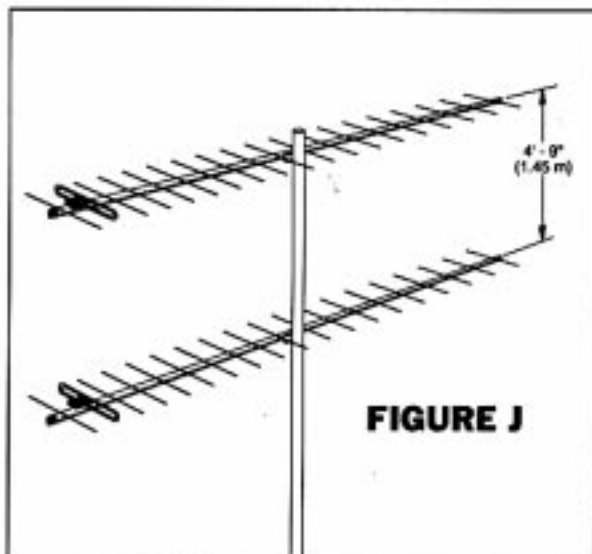

FIGURE J

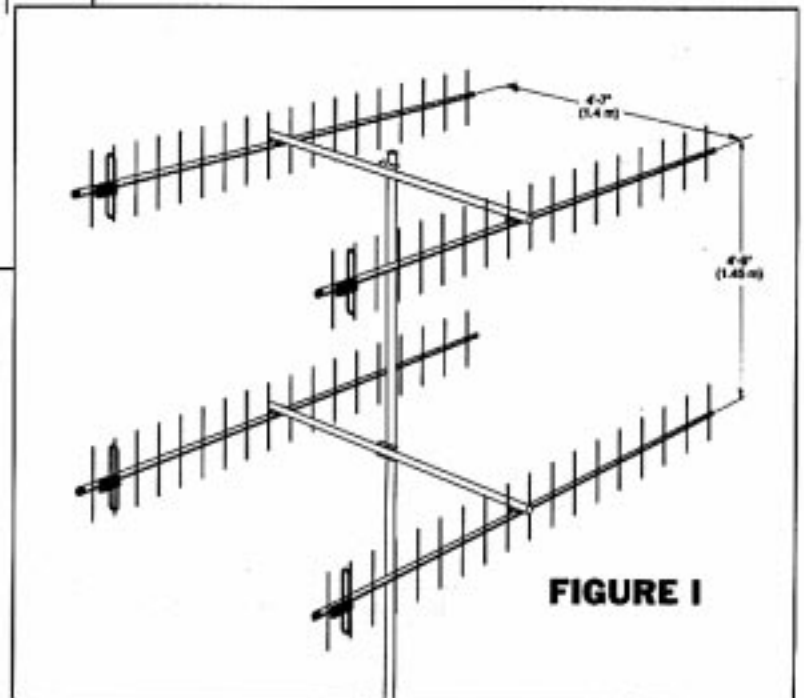

FIGURE I

When stacking antennas, all UltraMatches must be facing in the same direction for proper phasing. That is to say, vertically polarized antennas must have all UltraMatches on one side or the other. Horizontally polarized antennas must have all UltraMatches on the bottom.

SPECIFICATIONS

MODEL	719B
Frequency, MHz	430-450
No. Elements	19
Forward Gain, dBd	15.5
Front to Back Ratio, dB	25
SWR 1.2:1 Typical	
2:1 Bandwidth MHz	20
Power Rating, Watts PEP	2000
3 dB Beamwidth, Degrees	
E Plane	24
H Plane	19
Side Lobe Atten., dB, E Plane	60
Boom Length, ft (m)	13.5 (4.1)
Electrical Wavelength	6
Longest Element, in (cm)	13.75 (34.9)
Turning Radius, ft (m)	7.25 (2.2)
Mast Size Range, in (cm)	1.25-2
.....	(3.2-5.1)
Wind Load, ft ² (m ²)	1.2 (.11)
Weight, lb (kg)	5.6 (2.55)

LIMITED WARRANTY

Cushcraft Corporation, P.O. Box 4680, Manchester, New Hampshire 03108, warrants to the original consumer purchaser for one year from date of purchase that each Cushcraft antenna is free of defects in material or workmanship. If, in the judgement of Cushcraft, any such antenna is defective, then Cushcraft Corporation will, at its option, repair or replace the antenna at its expense within thirty days of the date the antenna is returned (at purchaser's expense) to Cushcraft or one of its authorized representatives. This warranty is in lieu of all other expressed warranties, any implied warranty is limited in duration to one year. Cushcraft Corporation shall not be liable for any incidental or consequential damages which may result from a defect. Some states do not allow limitations on how long an implied warranty lasts or exclusions or limitations of incidental or consequential damages, so the above limitation and exclusion may not apply to you. This warranty gives you specific legal rights, and you may also have other rights which vary from state to state. This warranty does not extend to any products which have been subject to misuse, neglect, accident or improper installation. Any repairs or alterations outside of the Cushcraft factory will nullify this warranty.



48 PERIMETER ROAD, MANCHESTER, NH 03108 USA
 603-627-7877 • TELEX 4949472 • FAX 603-627-1764
 E-mail: techsup@cushcraft.com

SPECIFICATIONS SUBJECT TO CHANGE WITHOUT NOTICE

TA5FA