

617-6B

6 METER BOOMER ANTENNA



TA5FA

WARNING

THIS ANTENNA IS AN ELECTRICAL CONDUCTOR. CONTACT WITH POWER LINES CAN RESULT IN DEATH OR SERIOUS INJURY. DO NOT INSTALL THIS ANTENNA WHERE THERE IS ANY POSSIBILITY OF CONTACT WITH OR HIGH VOLTAGE ARC-OVER FROM POWER CABLES OR SERVICE DROPS TO BUILDINGS. THE ANTENNA, SUPPORTING MAST AND/OR TOWER MUST NOT BE CLOSE TO ANY POWER LINES DURING INSTALLATION, REMOVAL, OR IN THE EVENT PART OF THE SYSTEM SHOULD ACCIDENTALLY FALL. FOLLOW THE GUIDELINES FOR ANTENNA INSTALLATIONS RECOMMENDED BY THE U.S. CONSUMER PRODUCT SAFETY COMMISSION AND LISTED IN THE ENCLOSED PAMPHLET.

Your Cushcraft antenna is designed and manufactured to give top performance and trouble free service. The antenna will perform as specified if the instructions and suggestions are followed and care is used in assembly and installation. When checking the components received in your antenna package use the parts lists in each section. It is easiest to identify the various dimensions of tubing by separating them into groups of the same diameter and length. If you are unable to locate any tube or component, check the inside of all tubing. **IMPORTANT:** save the weight label from the outside of the carton. Each antenna is weighed at the factory to verify the parts count. If you claim a missing part, you will be asked for the weight verification label. There is a master parts list on page 2.

LOCATION

Location of the antenna is very important. Surrounding objects such as trees, power lines, other antennas, etc. will seriously reduce efficiency. To minimize the effects of surrounding objects, mount the antenna as high and in the clear as possible. If metal guy wires are used, they should be broken with strain insulators. YOU MUST INSURE THAT NEITHER PEOPLE NOR PETS CAN COME IN CONTACT WITH YOUR ANTENNA WHILE IT IS IN OPERATION. DEADLY VOLTAGES AND CURRENTS MAY EXIST. ALSO, SINCE THE EFFECTS OF EXPOSURE TO RF ARE NOT FULLY UNDERSTOOD, LONG TERM EXPOSURE TO INTENSE RF FIELDS IS NOT RECOMMENDED. THERE IS A WARNING STICKER WHICH MUST BE ATTACHED TO THE BOOM AS SHOWN IN FIGURE G.

Plan your installation carefully. If you use volunteer helpers be sure that they are qualified to assist you. Make certain that everyone involved understands that you are in charge and that they must follow your instructions. If you have any doubts at all employ a professional antenna installation company to install your antenna.

MOUNTING

The mast mount bracket will accommodate up to a 2" OD (5.1 cm) mast. A 1 1/2" OD (3.8 cm) or larger heavy wall tubing mast should be used. A good heavy duty antenna rotator will provide the best service and longest life. Often it is desirable to mount several antennas on one mast. To keep possible interaction to a minimum, place your antennas as far apart as you can.

SYSTEM GROUNDING

Direct grounding of the antenna, mast and tower is very important. This serves as protection from lightning strikes and static buildup, and from high voltage which is present in the radio equipment connected to the antenna. A good electrical connection should be made to one or more ground rods (or other extensive ground system) directly at the base of the tower or mast, using at least #10 AWG ground wire and non-corrosive hardware. For details and safety standards, consult the National Electrical Code. You should also use a coaxial lightning arrester. Cushcraft offers several different models, such as LAC-1, LAC-2 and the LAC-4 series.

ASSEMBLY

Assemble your antenna by following the directions and illustrations in steps 1 through 6. After the antenna is completely assembled, verify dimensions and element spacings for accuracy. Then, return to the section below for final tuning.

TUNING PROCEDURE

The 617-6B does not normally require tuning after assembly. However, if you wish to check the VSWR before installation, please observe the following procedures. To prevent detuning the antenna, it should be tuned in place or at least 20 feet (6.1 m) above ground and clear of surrounding objects. Keep all metal obstructions such as guy wires and other antennas at least 20 feet (6.1 m) away since they will nullify any adjustment and degraded performance will result.

Run the coax cable from your transmitter to the area in which the antenna is going to be tested. The length of this cable or your feedline is not critical. Connect a good quality VSWR bridge to the end of this cable. Connect a 20 foot (6.1 m) or less length of cable from the VSWR bridge to the antenna. Set the transmitter to your center operating frequency. When you read VSWR, be sure you move far enough away from the antenna so that your body does not effect the reading.

Measure the VSWR. If it is high, move the T-Match clamps (#61) out away from the boom by 1/4" (.6 cm) and check the VSWR. If the VSWR improved, then continue moving the T-Match clamps out. If the VSWR deteriorated then move the T-Match clamps in towards the boom. Repeat this procedure until no further improvement can be made. You have matched your antenna to 50 Ohms. Then tighten all connections. Tape the feedline to the boom and mast.

TA5FA

MASTER PARTS LIST





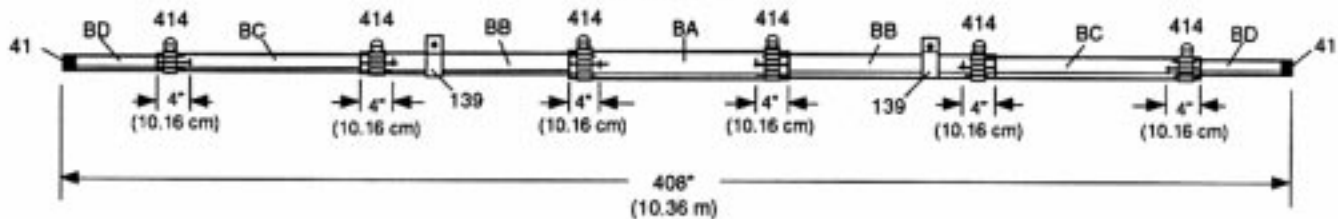

KEY	PART #	DESCRIPTION	QTY	KEY	PART #	DESCRIPTION	QTY
11	010011	8-32 stainless steel hex nut	7	941	011941	#8 stainless steel lock washer	7
27	050027	5/8" (1.59 cm) black plastic cap	12	BA		2" x 72" (5.1 x 182.9 cm) aluminum tubing slotted both ends	1
32	190032	3-1/2" (8.9 cm) U-bolt bracket	6	BB		1-7/8" x 72" (4.76 x 182.9 cm) aluminum tubing slotted one end	2
33	190033	3-1/2" (8.9 cm) U-bolt backing plate	5	BC		1-3/4" x 72" (4.45 x 182.9 cm) aluminum tubing slotted one end	2
41	050041	1-5/8" (4.13 cm) black plastic cap	2	BD		1-5/8" x 36" (4.13 x 91.4 cm) aluminum tubing	2
53	050053	1/2" (1.27 cm) black plastic cap	2	BE		7/8" x 28" (2.22 x 71.1 cm) aluminum tubing slotted both ends	2
63	170063	3-1/2" (8.9 cm) machined aluminum V-block	5	BF		3/4" x 48" (1.91 x 121.9 cm) aluminum tubing flattened and drilled one end.	4
79	010079	8-32 x 1/2" (1.3 cm) stainless steel machine screw	4	EA		3/4" x 48" (1.91 x 121.9 cm) aluminum tubing drilled for U-bolt and slotted both ends	6
115	050115	Connector boot	1	EB		5/8" x 37-1/2" (1.59 x 95.2 cm) aluminum tubing	2
116	240116	Silicone package	1	EC		5/8" x 35-1/2" (1.59 x 90.2 cm) aluminum tubing	2
118	010118	5/16" (.79 cm) stainless steel hex nut	24	ED		5/8" x 31-3/8" (1.59 x 79.7 cm) aluminum tubing	2
119	010119	5/16" (.79 cm) stainless steel lock washer	26	EE		5/8" x 30-15/16" (1.59 x 78.6 cm) aluminum tubing	2
124	190124	Connector strap	1	EF		5/8" x 31-1/8" (1.59 x 79.1 cm) aluminum tubing	2
130	190130	6" x 6" (15.24 x 15.24 cm) aluminum mounting plate	1	EG		5/8" x 25-15/16" (1.59 x 65.9 cm) aluminum tubing	2
135	190135	Connector bracket assembly	1	ET		1/2" x 23-1/4" (1.27 x 59.1 cm) T-match tubes flattened and punched one end	2
139	200139	1-7/8" (4.76 cm) brace clamp	2	HF		Coaxial balun (RG11) with vinyl boots	1
140	010140	5/16" x 1-1/2" (.79 x 3.8 cm) stainless steel hex head bolt	2				
326	290326	Danger label	1				
404	010404	2-1/8" x 3" (5.4 x 7.6 cm) stainless steel U-bolt	5				
405	010405	2" x 4" (5.1 x 10.2 cm) stainless steel U-bolt	6				
409	030409	7/8" (2.22 cm) stainless steel worm clamp	16				
414	030414	2-1/4" (5.72 cm) stainless steel worm clamp	6				
461	202461	1/2" x 3/4" (1.27 x 1.9 cm) T-match clamp	2				

#1 - BOOM ASSEMBLY

Begin by sliding worm clamps (414) over the slotted ends of tube BA. Mark one end of both BB tubes 4" (10.16 cm) from the end. Insert sections BB tubes into the BA tube up to the 4" (10.16 cm) mark that you just made and secure by tightening the worm clamps. Slide brace clamps (139) onto both BB sections. Mark the BC and BD tubes 4" (10.16 cm) from the end. Insert BC tubes into the BB tubes and secure with worm clamps (414). Insert the BD tubes into the BC tubes and secure with worm clamps (414). Press the end caps (41) on to the BD tubes.

FIGURE A

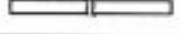

KEY	P/N	DISPLAY	DESC	SIZE	QTY	KEY	P/N	DISPLAY	DESC	SIZE	QTY
BA			ALUM TUBE	2 x 72" (5.1 x 182.9 cm)	1	414	030414		SS WORM CLAMP	2-1/4" (5.7 cm)	6
BB			ALUM TUBE	1-7/8" x 72" (4.76 x 182.9 cm)	2	41	050041		PLASTIC CAP	1-5/8" (4.13 cm)	2
BC			ALUM TUBE	1-3/4" x 72" (4.45 x 182.9 cm)	2	139	200139		BRACE CLAMP	1-7/8" (4.76 cm)	2
BD			ALUM TUBE	1-5/8" x 36" (4.13 x 91.4 cm)	2						

#2 - ELEMENT ASSEMBLY

On one of the EA tubes, slide on both T-Match clamps (461). This will be the driven element. Place a worm clamp (409) on the end of each EA tube. Referring to the drawing below, insert the appropriate end tube pairs 3" (7.6 cm) into the EA tubes. Push the plastic caps onto the end of each element. Adjust the end tubes to the dimensions shown below. Tighten the worm clamps. Attach all the elements except the driven element (#2) to the boom using the spacing shown. (Figures B and C.) Tighten nuts (118) making sure not to overtighten.

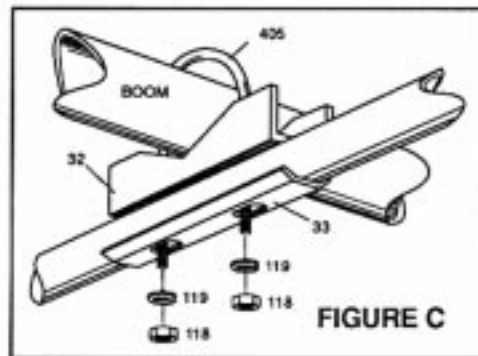
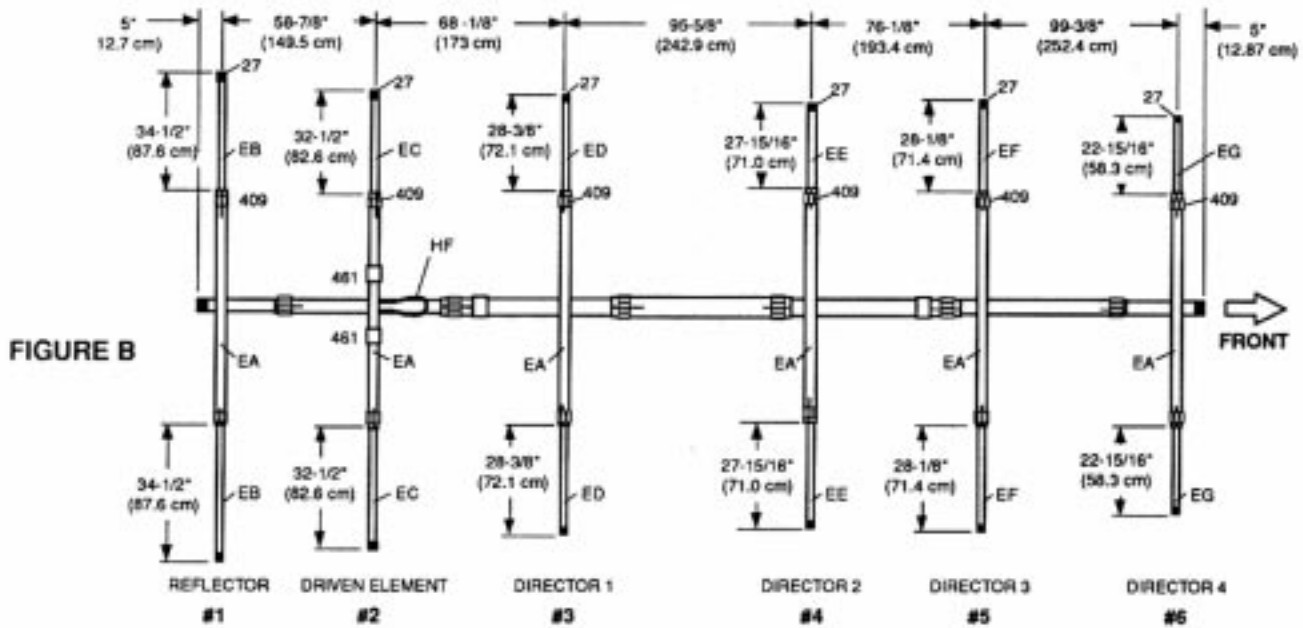

KEY	P/N	DISPLAY	DESC	SIZE	QTY	KEY	P/N	DISPLAY	DESC	SIZE	QTY
EA			ALUM TUBE	3/4" x 48" (1.91 x 121.9 cm)	6	409	030409		SS WORM CLAMP	7/8" (2.22 cm)	12
EB			ALUM TUBE	5/8" x 37-1/2" (1.59 x 95.2 cm)	2	32	190032		U-BOLT BRACKET	3-1/2" (8.9 cm)	6
EC			ALUM TUBE	5/8" x 35-1/2" (1.59 x 90.2 cm)	2	33	190033		U-BOLT BK PLATE	3-1/2" (8.9 cm)	5
ED			ALUM TUBE	5/8" x 31-3/8" (1.59 x 79.7 cm)	2	405	010405		SS U-BOLT	2" x 4" (5.1 x 10.2 cm)	6
EE			ALUM TUBE	5/8" x 30-15/16" (1.59 x 78.6 cm)	2	118	010118		SS HEX NUT	5/16" (.79 cm)	12
EF			ALUM TUBE	5/8" x 31-1/8" (1.59 x 79.1 cm)	2	119	010119		SS LOCK WASHER	5/16" (.79 cm)	12
EG			ALUM TUBE	5/8" x 25-15/16" (1.59 x 65.9 cm)	2	461	202461		T-MATCH CLAMP	1/2" x 3/4" (1.27 x 1.9 cm)	2
27	050027		PLASTIC CAP	5/8" (1.6 cm)	12						

#3 - T-MATCH ASSEMBLY

FIGURE D

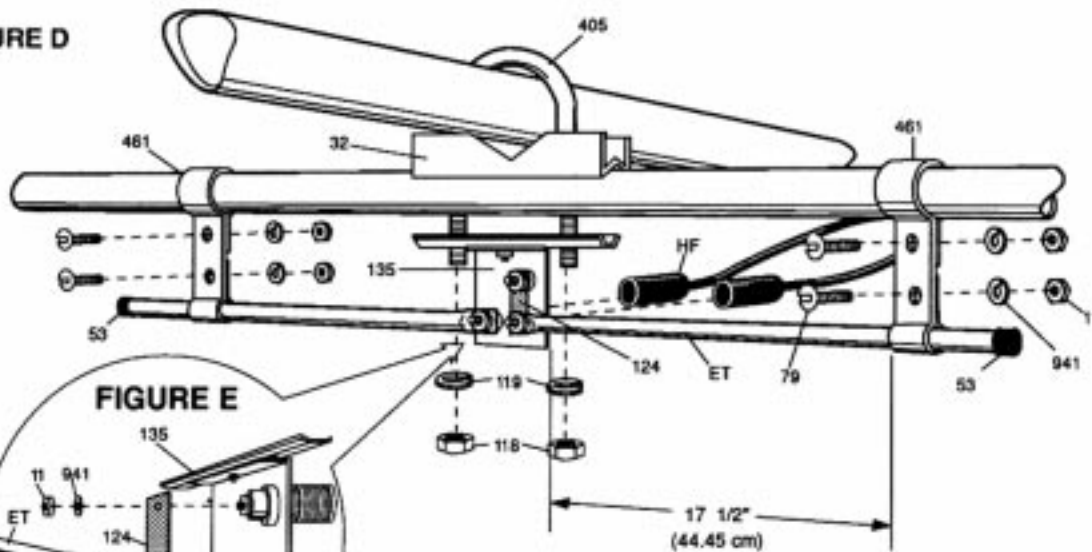
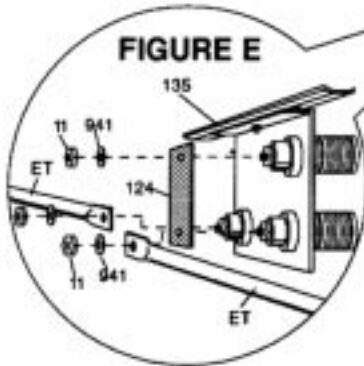

FIGURE E



Assemble the T-Match to the dipole as illustrated in figure D. Position the Reddi-Match clamps (461) according to the diagram. Place the connector strap (124) between the upper and lower connectors (figure E). The flattened end of the T-Match tubes (ET) attach to the lower connectors on the bracket. Secure with washers (41) and nuts (11). The feed line is attached to the upper connector and the balun to the two lower connectors. Mount the dipole to the boom at the position illustrated in figure B using lock washers (119), nuts (118), and U-bolt (405). Tighten U-bolt taking care not to overtighten.

KEY	P/N	DISPLAY	DESC	SIZE	QTY	KEY	P/N	DISPLAY	DESC	SIZE	QTY
11	010011		SS HEX NUT	8-32	7	124	190124		CONNECTING STRAP	5/8" x 2" (1.58 x 5.1 cm)	1
32	190032		U-BOLT BRACKET	3-1/2" (8.9 cm)	1	135	190135		CONNECTOR BRACKET		1
53	050053		PLASTIC CAP	1/2" (1.27 cm)	2	461	202461		T-MATCH CLAMP	1/2" x 3/4" (1.27 x 1.9 cm)	2
79	010079		SS MACHINE SCREW	8-32 x 1/2" (1.3 cm)	4	941	011941		SS LOCK WASHER	#8	7
118	010118		SS HEX NUT	5/16" (8 cm)	2	ET			T-MATCH TUBES	1/2 x 23-1/4" (1.3 x 59.1 cm)	2
119	010119		SS LOCK WASHER	5/16" (.79 cm)	2	HF			COAXIAL BALUN		1

#4 - BALUN AND FEED LINE

When connecting the balun, coat the outside of the aluminum connector threads and the PL-259 with silicone grease provided. Do not coat the connector center conductor pin or socket with silicone. Slide the vinyl boots over the connectors and against the plate for a good weather tight connection. Follow the same procedure for your 50 Ohm coaxial feed cable and be sure to slide the vinyl boot over the cable before attaching the PL-259 connector. When taping feedline and balun to the boom, it's a good idea to form a drip loop in the coax to help protect the connector from water damage (figure F). Before attaching the feed line permanently, tune the antenna as outlined on page 2. The antenna is designed for use with 50 Ohm coaxial cable terminated with a PL-259 connector. Any length of feed line can be used with your 617-6B. The shortest length cable will have the least loss.



FIGURE F

KEY	P/N	DISPLAY	DESC	SIZE	QTY
115	050115		CONN BOOT		1
116	240116		SILICONE PACKAGE		1









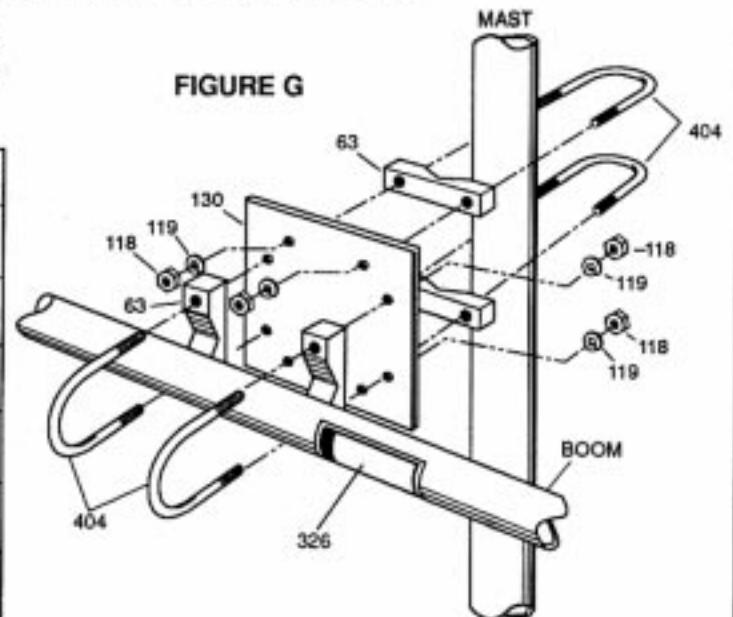

#5 - BOOM TO MAST ASSEMBLY

Assemble and mount the boom/mast bracket at the approximate balance point. Refer to figure J for the balance point and figure G for assembly. Tighten the U-bolts taking care not to crush the boom. Place the danger label (326) on the boom as shown.

KEY	P/N	DISPLAY	DESC	SIZE	QTY
63	170063		ALUM V-BLOCK	3-1/2" (8.9 cm)	4
119	010119		SS LOCK WASHER	5/16" (.8 cm)	8
118	010118		SS HEX NUT	5/16" (.8 cm)	8
130	190130		ALUM PLATE	6 x 6" (15.2 X 15.2 cm)	1
326	290326		DANGER LABEL		1
404	010404		SS U-BOLT	2-1/8 x 3" (5.4 x 7.6 cm)	4



#6 - DIAGONAL BRACE ASSEMBLY

KEY	P/N	DISPLAY	DESC	SIZE	QTY
BE			ALUM TUBING	7/8" x 26" (2.22 x 71.1 cm)	2
BF			ALUM TUBING	3/4" x 48" (1.91 x 121.9 cm)	4
63	170063		ALUM V-BLOCK	3-1/2" (8.9 cm)	1
118	010118		SS HEX NUT	5/16" (.8 cm)	4
119	010119		SS LOCK WASHER	5/16" (.8 cm)	6
139	200139		BRACE CLAMP	1-7/8" (4.8 cm)	2
140	010140		SS HEX BOLT	5/16" x 1-1/2" (.8 x 3.8 cm)	2
404	010404		SS U-BOLT	2-1/8" x 3" (5.4 x 7.6 cm)	1
409	030409		SS WORM CLAMP	7/8" (2.2 cm)	4

Assemble and attach the diagonal braces to the boom as illustrated below. To begin, insert each BF brace section 3" into the slotted tube (BE). Connect the assembled braces to the brace clamps already located on the boom. Locate the brace clamps (139) as shown in figure J. Attach the other end of the braces to the U-bolt assembly which secures to the mast approximately 50" (127 cm) above the antenna. Experiment with the height of the U-bolt assembly until the antenna is level. Tighten the brace U-bolt.

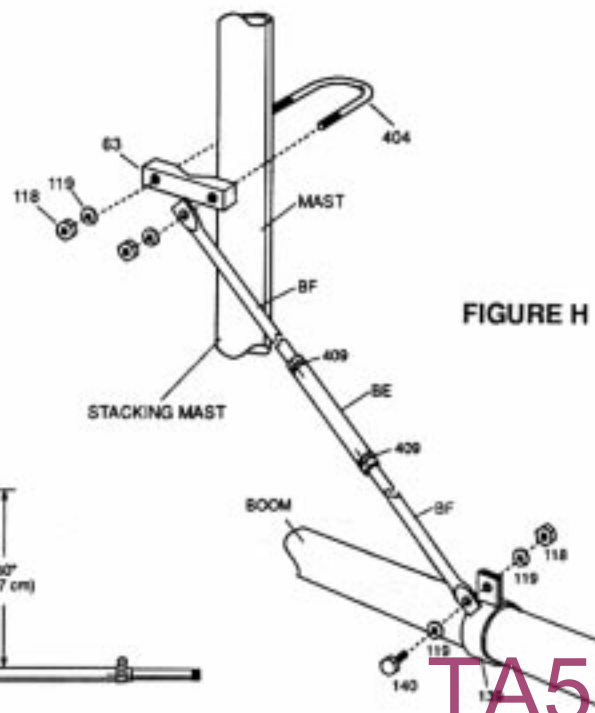
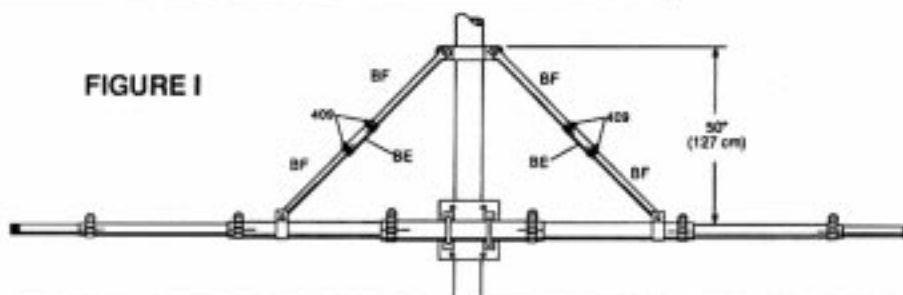

FIGURE I



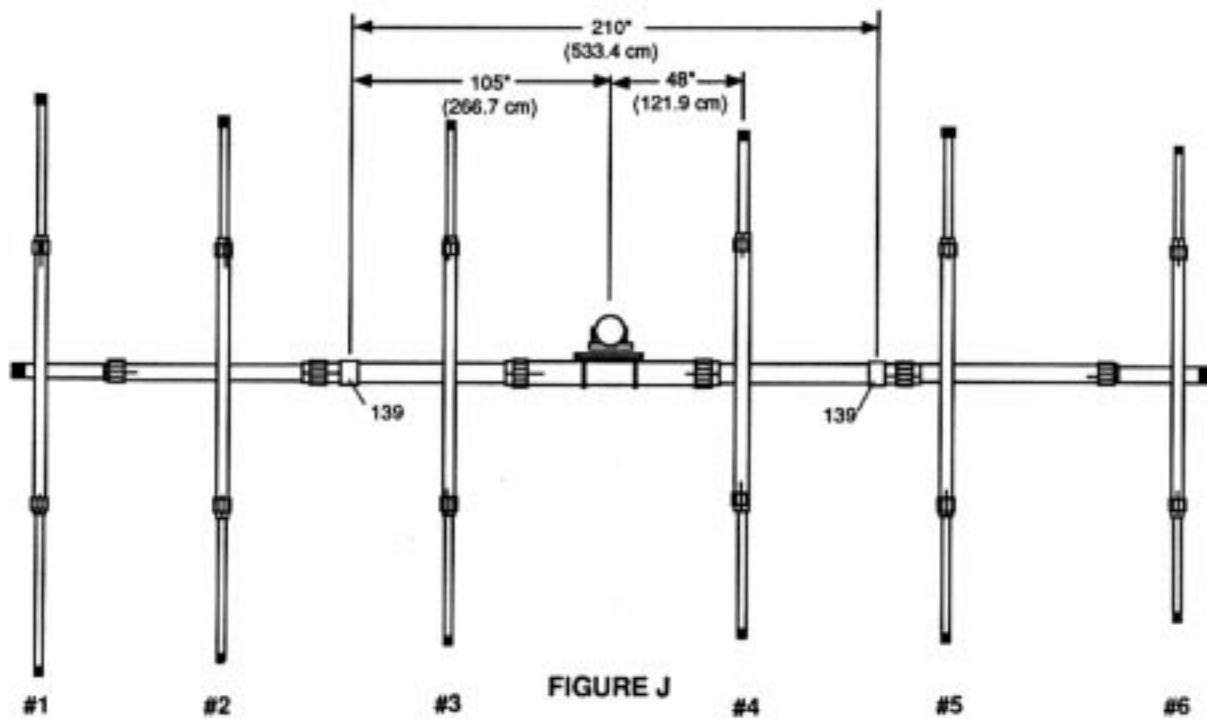

FIGURE J

SPECIFICATIONS			
MODEL	617-6B	Side Lobe Atten., dB, E Plane	60
Frequency, MHz	50-51	Boom Length, ft (m)	34 (10.36)
No. Elements	6	Electrical Wavelength	1.7
Forward Gain, dBd	14.0	Longest Element, in (cm)	117 (297.2)
Front to Back Ratio, dB	30	Turning Radius, ft (m)	17.7 (5.39)
SWR 1.2:1 Typical		Mast Size Range, in (cm)	1.5-2 (3.8-5.1)
2:1 Bandwidth MHz	>1	Wind Load, ft² (m²)	4.8 (.45)
Power Rating, Watts PEP	2000	Weight, lb (kg)	26 (11.79)
3 dB Beamwidth, Degrees			
E Plane	2 x 19		
H Plane	2 x 20		

LIMITED WARRANTY

Cushcraft Corporation, P.O. Box 4680, Manchester, New Hampshire 03108, warrants to the original consumer purchaser for one year from date of purchase that each Cushcraft antenna is free of defects in material or workmanship. If, in the judgement of Cushcraft, any such antenna is defective, then Cushcraft Corporation will, at its option, repair or replace the antenna at its expense within thirty days of the date the antenna is returned (at purchasers expense) to Cushcraft or one of its authorized representatives. This warranty is in lieu of all other expressed warranties, any implied warranty is limited in duration to one year. Cushcraft Corporation shall not be liable for any incidental or consequential damages which may result from a defect. Some states do not allow limitations on how long an implied warranty lasts or exclusions or limitations of incidental or consequential damages, so the above limitation and exclusion may not apply to you. This warranty gives you specific legal rights, and you may also have other rights which vary from state to state. This warranty does not extend to any products which have been subject to misuse, neglect, accident or improper installation. Any repairs or alterations outside of the Cushcraft factory will nullify this warranty.



48 PERIMETER ROAD, MANCHESTER, NH 03108

TA5FA