

10-3CD

SKYWALKER

**10 METER
3 ELEMENT YAGI**



951349 (10/90)

TA5FA

WARNING

THIS ANTENNA IS AN ELECTRICAL CONDUCTOR. CONTACT WITH POWER LINES CAN RESULT IN DEATH, OR SERIOUS INJURY. DO NOT INSTALL THIS ANTENNA WHERE THERE IS ANY POSSIBILITY OF CONTACT WITH OR HIGH VOLTAGE ARC-OVER FROM POWER CABLES OR SERVICE DROPS TO BUILDINGS. THE ANTENNA, SUPPORTING MAST AND/OR TOWER MUST NOT BE CLOSE TO ANY POWER LINES DURING INSTALLATION, REMOVAL OR IN THE EVENT PART OF THE SYSTEM SHOULD ACCIDENTALLY FALL. FOLLOW THE GUIDELINES FOR ANTENNA INSTALLATIONS RECOMMENDED BY THE U.S. CONSUMER PRODUCT SAFETY COMMISSION AND LISTED IN THE ENCLOSED PAMPHLET.

Your Cushcraft 10 meter beam is designed and manufactured to give top performance and trouble free service. The antenna will perform as specified if the instructions and suggestions are followed and care is used in assembly and installation. When checking the components received in your antenna package use the parts lists in each section. It is easiest to identify the various dimensions of tubing by separating them into groups of the same diameter and length. If you are unable to locate any tube or component, check the inside of all tubing. **IMPORTANT:** save the weight label from the outside of the carton. Each antenna is weighed at the factory to verify the parts count. If you claim a missing part, you will be asked for the weight verification label. There is a master parts list on page 3.

LOCATION

Location of the antenna is very important. Surrounding objects such as trees, power lines, other antennas, etc. will seriously reduce efficiency. To minimize the effects of surrounding objects, mount the antenna as high and in the clear as possible. If metal guy wires are used, they should be broken with strain insulators. **YOU MUST INSURE THAT NEITHER PEOPLE OR PETS CAN COME IN CONTACT WITH YOUR ANTENNA WHILE IT IS IN OPERATION. DEADLY VOLTAGES AND CURRENTS MAY EXIST. ALSO, SINCE THE EFFECTS OF EXPOSURE TO RF ARE NOT FULLY UNDERSTOOD, LONG TERM EXPOSURE TO INTENSE RF FIELDS IS NOT RECOMMENDED. THERE IS A WARNING STICKER WHICH MUST BE ATTACHED TO THE BOOM AS SHOWN IN FIGURE F.**

Plan your installation carefully. If you use volunteer helpers be sure that they are qualified to assist you. Make certain that everyone involved understands that you are in charge and that they must follow your instructions. If you have any doubts at all employ a professional antenna installation company to install your antenna.

MOUNTING

The mast mount bracket will accommodate up to a 2" OD (5.1 cm) mast. A 1 1/2" OD (3.8 cm) or larger heavy wall tubing mast should be used. A good heavy duty antenna rotator will provide the best service and longest life. Often it is desirable to mount several antennas on one mast. To keep possible interaction to a minimum, place your antennas as far apart as you can.

SYSTEM GROUNDING

Direct grounding of the antenna, mast and tower is very important. This serves as protection from lightning strikes and static buildup, and from high voltage which is present in the radio equipment connected to the antenna. A good electrical connection should be made to one or more ground rods (or other extensive ground system) directly at the base of the tower or mast, using at least #10AWG ground wire and non-corrosive hardware. For details and safety standards, consult the National Electrical Code. You should also use a coaxial lightning arrester. Cushcraft offers several different models, such as LAC-1, LAC-2 and the LAC-4 series.

ASSEMBLY

Assemble your antenna by following the directions and illustrations in steps 1 through 6. After the antenna is completely assembled, verify dimensions and element spacings for accuracy. Then, return to the section below for final tuning.

TUNING PROCEDURE





If you wish to check the VSWR before installation, please observe the following procedures. Temporarily mount the antenna with the boom vertical, reflector at least one foot (30 cm) off the ground on a non-metallic support (wooden box), to prevent detuning the antenna. Guy the top of the boom. Do not use line with wire in it (some clotheslines have a wire core). Keep other antennas, metal objects and guy lines clear of the antenna under test. Do not attempt to tune the Yagi near the ground with the boom parallel to the ground since ground effects will nullify any adjustment and degraded performance will result.

Run the coax cable from your transmitter to the area in which the antenna is going to be tested. The length of this cable or your feedline is not critical. Connect a good quality VSWR bridge to the end of this cable. Connect a short length of cable [10 ft (305 cm) or less] from the VSWR bridge to the antenna. Set the transmitter to your center operating frequency. When you read VSWR, be sure you move far enough away from the antenna so that your body does not effect the reading.

Measure the VSWR. If it is high, move the Reddi-Match clamp (108) by 1/4" (.6 cm) in one direction and check the VSWR. If the VSWR improved, then continue moving the Reddi-Match clamp in the same direction. If the VSWR deteriorated then move the Reddi-Match clamp in the opposite direction. Repeat this procedure until no further improvement can be made. You have matched your antenna to 50 Ohms. Then tighten all connections. Tape the feedline to the boom and mast.

MASTER PARTS LIST

KEY	PART #	DESCRIPTION	QTY	KEY	PART #	DESCRIPTION	QTY
9	010009	8-32 x 5/8" (1.6 cm) stainless steel round head slotted machine screw	2	402	010402	1-1/2" x 3-3/4" (3.8 x 9.5 cm)	3
10	010010	#8 stainless steel internal tooth lock washer	3	403	010403	1-5/8" x 3" (4.1 x 7.6 cm) stainless steel U-bolt	2
11	010011	8-32 stainless steel hex nut	3	404	010404	2-1/8" x 3" (5.4 x 7.6 cm) stainless steel U-bolt	2
27	050027	5/8" (1.6 cm) black plastic cap	6	409	030409	7/8" (2.22 cm) stainless steel worm clamp	12
33	190033	1-1/2" (3.81 cm) U-bolt backing plate	2	413	030413	1-3/4" (4.44 cm) stainless steel worm clamp	2
46	050046	1-1/2" (3.8 cm) black plastic cap	2	CB		Coaxial connector bracket assembly	1
70	190070	6" x 4" (15.2 x 10.2 cm) aluminum plate	1	RM		Reddi-Match tube assembly	1
84	010084	1/4" (.63 cm) stainless steel lock washer	6	BA		1-5/8" x 12" (4.1 x 30.5 cm) aluminum tubing slotted	1
85	010085	1/4"-20 stainless steel hex nut	6	BB		1-1/2" x 48" (3.8 x 121.9 cm) aluminum tubing	1
108	200108	3/8" x 7/8" (.95 x 2.22 cm) Reddi Match strap	1	BC		1-1/2" x 72" (3.8 x 182.9 cm) aluminum tubing	1
115	050115	Connector boot	1	EA		7/8" x 50" (2.2 x 127 cm) aluminum tubing drilled for U-bolt and slotted both ends	3
116	240116	Silicone Package	1	EB		3/4" x 48" (1.9 x 121.9 cm) aluminum tubing slotted one end	6
118	010118	5/16" (.8 cm) stainless steel hex nut	8	EC		5/8" x 41" (1.6 x 104.1 cm) aluminum tubing	2
119	010119	5/16" (.8 cm) stainless steel lock washer	8	ED		5/8" x 35" (1.6 x 88.9 cm) aluminum tubing	2
143	190143	Aluminum U-bolt bracket	3	EE		5/8" x 29-1/2" (1.6 x 74.9 cm) aluminum tubing	2
326	290326	Danger label	1				

KEY	P/N	DISPLAY	DESC	SIZE	QTY
BA			ALUM TUBE	1-5/8" x 12" (4.1 x 30.5 cm)	1
BB			ALUM TUBE	1-1/2" x 48" (3.8 x 121.9 cm)	1
BC			ALUM TUBE	1-1/2" x 72" (3.8 x 182.9 cm)	1
413	030413		SS WORM CLAMP	1-3/4" (4.4 cm)	2
46	050046		PLASTIC CAP	1-1/2" (3.8 cm)	2

#1 - BOOM ASSEMBLY

Place a worm clamp (413) over each end of the BA tube. Insert the BB and BC tubes 6" (15.2 cm) into the BA tube. Tighten the worm clamps and push the end caps (46) onto each end of the boom.

FIGURE A

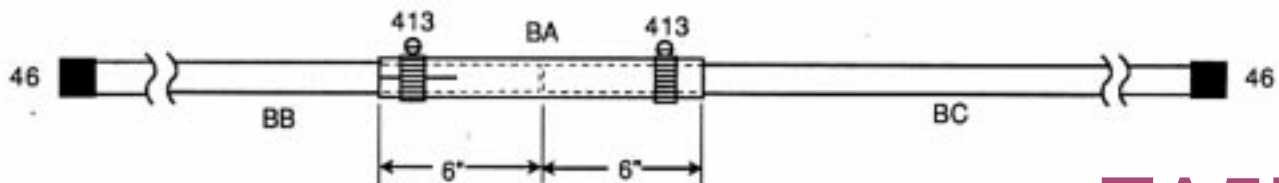

TA5FA

#2 - ELEMENT ASSEMBLY

Assemble the 3 elements according to the illustration below. Slide the Reddi Match clamp (108) onto one of the EA tubes. This will be the driven element. Place clamps (409) onto all the slotted ends of the EA tubes. Mark the unslotted end of the EB tubes 4 inches (10.2 cm) from the end. Insert the EB tubes into the EA tubes to the 4 inch mark and tighten the clamps. Place clamps (409) onto all the slotted ends of the EB tubes. Insert the EC, ED and EE tubes into the appropriate element according to the figure below. Adjust the element tips to the dimensions listed on Chart A. The dimensions in column 2 are recommended for general coverage operation. Tighten all clamps. Check the overall element lengths per Chart A. Install caps (27) on element tips.

FIGURE B

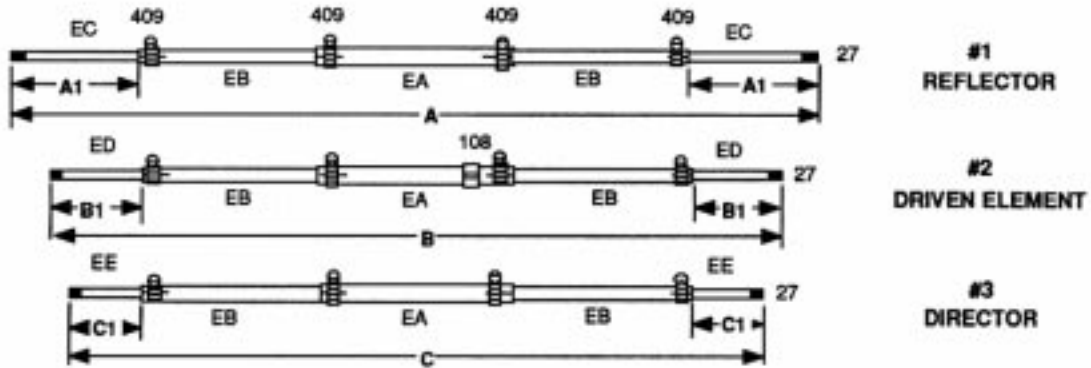

KEY	P/N	DISPLAY	DESC	SIZE	QTY	KEY	P/N	DISPLAY	DESC	SIZE	QTY
EA			ALUM TUBE	7/8" x 50" (2.2 x 127 cm)	3	EE			ALUM TUBE	5/8" x 29-1/2" (1.6 x 74.9 cm)	2
EB			ALUM TUBE	3/4" x 48" (1.9 x 122 cm)	6	108	200108		REDDI-M STRAP	3/8 x 7/8" (.95 x 2.22 cm)	1
EC			ALUM TUBE	5/8" x 41" (1.6 x 104.1 cm)	2	27	050027		PLASTIC CAP	5/8" (1.6 cm)	6
ED			ALUM TUBE	5/8" x 35" (1.6 x 88.9 cm)	2	409	030409		SS WORM CLAMP	7/8" (2.22 cm)	12

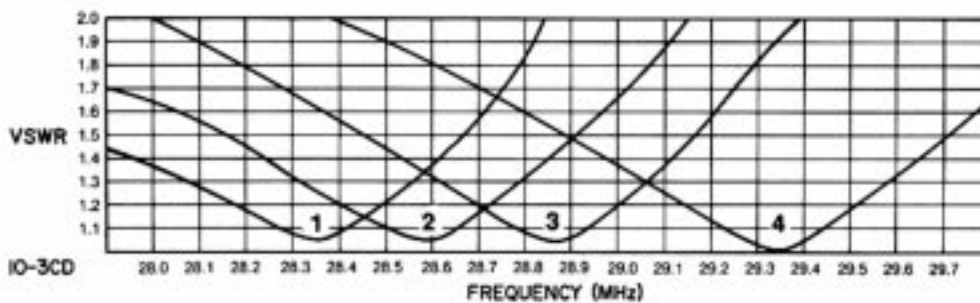

CHART A

FREQUENCY MHz	1 28.000 - 28.970		2 28.120 - 29.100		3 28.400 - 29.250		4 28.850 - 29.7000	
DIMENSION	in.	cm	in.	cm	in.	cm	in.	cm
A	213-1/2	542.3	212	538.5	210-1/2	534.7	207	525.8
A1	37-3/4	95.9	37	94.0	36-1/4	92.1	34-1/2	87.6
B	202-1/2	514.4	201	510.5	199-1/2	506.7	195-1/2	496.6
B1	32-1/4	81.9	31-1/2	80.0	30-3/4	78.1	28-3/4	73.0
C	190	482.6	189	480.1	187-1/2	476.2	183	464.8
C1	26	66.0	25-1/2	64.8	24-3/4	62.9	22-1/2	57.2

#3 - ELEMENT MOUNTING

Mount the element/boom brackets (143) as shown in figure C and E. Position the elements on the boom as shown in figure D. The longest element (reflector) is #1. Align the elements and tighten the U-bolts. Note that the driven element backing plate includes the connector bracket (CB) (figure E). This should be mounted with the connector pointing to the center of the boom to allow easy connection of the feedline.

FIGURE C

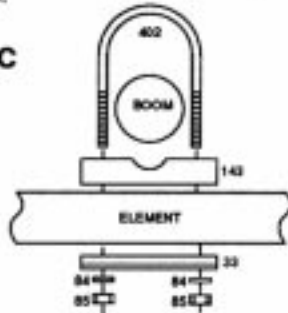
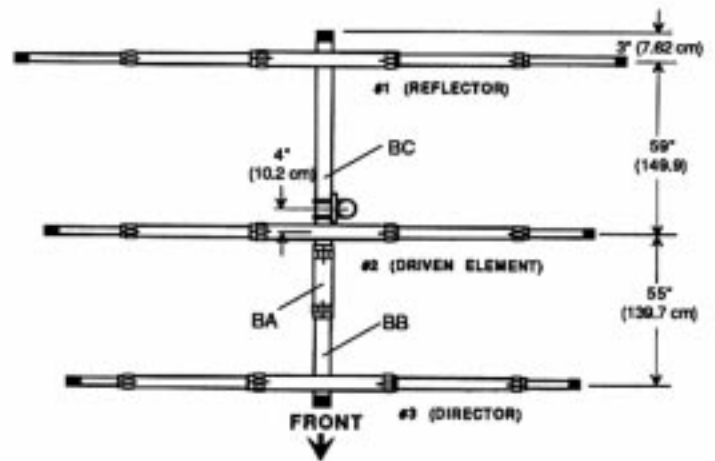

FIGURE D



KEY	P/N	DISPLAY	DESC	SIZE	QTY
33	190033		BACKING PLATE	1-1/2" (5.4 cm)	2
84	010084		SS LOCK WASHER	1/4" (.63 cm)	4
85	010085		SS HEX NUT	1/4"-20 (.63 cm)	4

KEY	P/N	DISPLAY	DESC	SIZE	QTY
143	190143		U-BOLT BRACKET		2
402	010402		SS U-BOLT	1-1/2"x3-3/4" (3.81 x 9.53 cm)	2

FIGURE E

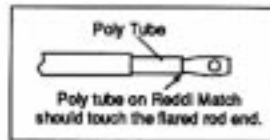
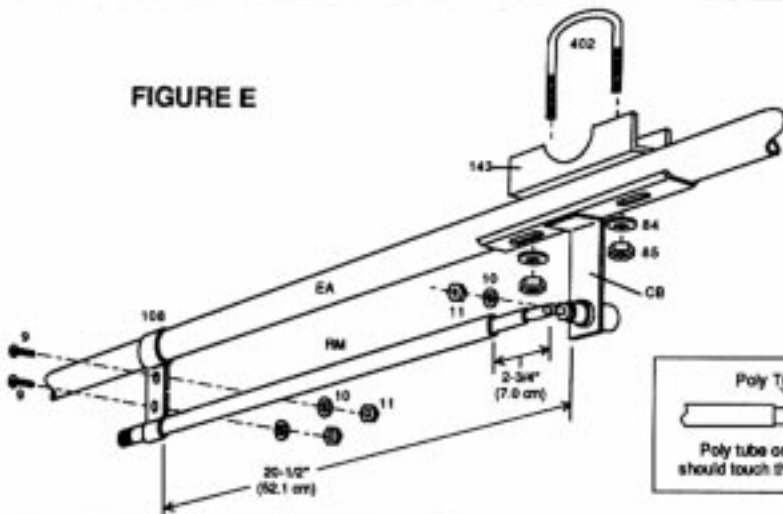





#4 - REDDI-MATCH ASSEMBLY

Mount the Reddi-Match to the driven element #2 as shown in figure E. The tuning strap (108) should already be on the element. Slide the Reddi-Match tube (RM) through the tuning strap. Connect the flattened rod to the screw on the connector. Attach the driven element to the boom using U-bolt (402) with lock washer (84) and hex nut (85) with the connector facing the director element. Slide the poly tube over the rod up to the flattened end. Adjust the dimensions shown and tighten all connectors.

KEY	P/N	DISPLAY	DESC	SIZE	QTY
9	010009		SS MACHINE SCREW	8-32 x 5/8" (1.6 cm)	2
10	010010		SS LOCK WASHER	#8	3
11	010011		SS HEX NUT	8-32	3
84	010084		SS LOCK WASHER	1/4" (.63 cm)	2
85	010085		SS HEX NUT	1/4"-20 (.63 cm)	2

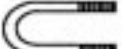

KEY	P/N	DISPLAY	DESC	SIZE	QTY
108	200108		REDDI-M CLAMP	3/8 x 7/8" (.95 x 2.22 cm)	1
143	190143		U-BOLT BRACKET		1
402	010402		SS U-BOLT	1-1/2"x3-3/4" (3.81 x 9.53 cm)	1
CB			CONNECTOR BRACKET		1
	REDDI MATCH		REDDI MATCH		

KEY	P/N	DISPLAY	DESC	SIZE	QTY
70	190070		ALUM PLATE	4" x 6" (10.2 x 15.2 cm)	1
118	010118		SS HEX NUT	5/16" (.8 cm)	8
119	010119		SS LOCK WASHER	5/16" (.8 cm)	8
326	290326		DANGER LABEL		1
403	010403		SS U-BOLT	1-5/8" x 3" (4.1 x 7.6 cm)	2
404	010404		SS U-BOLT	2-1/8" x 3" (5.4 x 7.6 cm)	2

#5 - BOOM TO MAST ASSEMBLY

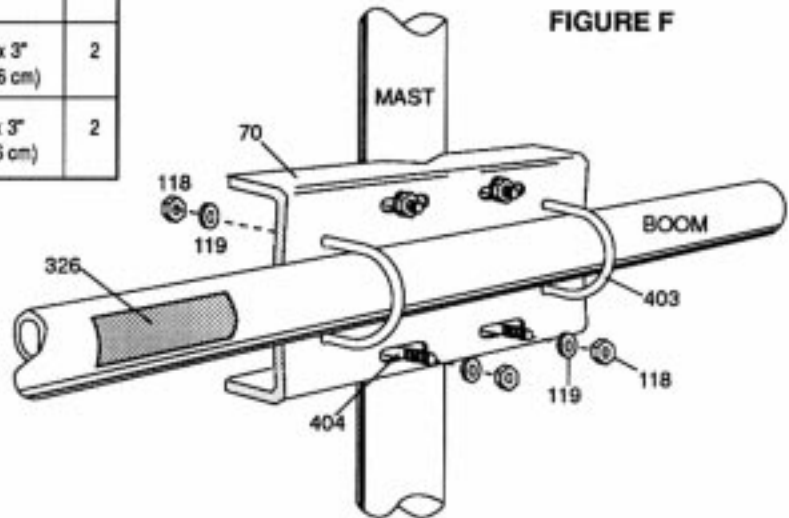
Assemble and mount the boom to mast bracket assembly at the balance point. Refer to figure D for the approximate balance point and figure F for assembly. Place the danger label (326) on the boom as shown in figure F.



KEY	P/N	DISPLAY	DESC	SIZE	QTY
115	050115		CONN BOOT		1
116	240116		SILICONE GREASE PACKAGE		1

#6 - FEEDLINE ASSEMBLY

Before attaching the feedline permanently, tune the antenna as outlined on page 2. The antenna is designed for use with 50 Ohm coaxial cable terminated with a PL-259 connector. Any length of feedline can be used with your Yagi. The shortest length cable will have the least loss. A connector boot is included for use with your new antenna. See figure G. Slide the boot over the cable before attaching your PL-259. Coat only the outside connector threads and shell with silicone grease. Do not coat the center pin or receptacle. After the PL-259 is firmly screwed on to the antenna connector, slide the vinyl boot over the connector and against the connector bracket for a good weather-tight connection. Tape the feedline down the mast.

FIGURE G



SPECIFICATIONS

Frequency	28.0-29.7 MHz
Forward Gain	8.0 dBd
Front to Back Ratio	30 dB
SWR Typical	1.2:1
Boom Length	10 ft. (3.05 m)
Longest Element	17.66 ft. (5.38 m)
Turning Radius	10 ft. (3.05 m)
Wind Surface Area	2.3 ft ² (.21 m ²)
Weight	11 lb (5.0 kg)
Mast Size Range	1.5-2 in. (3.8-5.1 cm)

LIMITED WARRANTY

Cushcraft Corporation, P.O. Box 4680, Manchester, New Hampshire 03108, warrants to the original consumer purchaser for one year from date of purchase that each Cushcraft antenna is free of defects in material or workmanship. If, in the judgement of Cushcraft, any such antenna is defective, then Cushcraft Corporation will, at its option, repair or replace the antenna at its expense within thirty days of the date the antenna is returned (at purchasers expense) to Cushcraft or one of its authorized representatives. This warranty is in lieu of all other expressed warranties, any implied warranty is limited in duration to one year. Cushcraft Corporation shall not be liable for any incidental or consequential damages which may result from a defect. Some states do not allow limitations on how long an implied warranty lasts or exclusions or limitations of incidental or consequential damages, so the above limitation and exclusion may not apply to you. This warranty gives you specific legal rights, and you may also have other rights which vary from state to state. This warranty does not extend to any products which have been subject to misuse, neglect, accident or improper installation. Any repairs or alterations outside of the Cushcraft factory will nullify this warranty.



48 PERIMETER ROAD, MANCHESTER, NH 03108
603-627-7877 / TELEX 4949472 / FAX 603-627-1764

SPECIFICATIONS SUBJECT TO CHANGE WITHOUT NOTICE

TA5FA