

ASL2010

13.5-32 MHz Log Periodic Antenna



951450-16/94
TA5FA

WARNING

THIS ANTENNA IS AN ELECTRICAL CONDUCTOR. CONTACT WITH POWER LINES CAN RESULT IN DEATH, OR SERIOUS INJURY. DO NOT INSTALL THIS ANTENNA WHERE THERE IS ANY POSSIBILITY OF CONTACT WITH OR HIGH VOLTAGE ARC-OVER FROM POWER CABLES OR SERVICE DROPS TO BUILDINGS. THE ANTENNA, SUPPORTING MAST AND/OR TOWER MUST NOT BE CLOSE TO ANY POWER LINES DURING INSTALLATION, REMOVAL, OR IN THE EVENT PART OF THE SYSTEM SHOULD ACCIDENTALLY FALL. FOLLOW THE GUIDELINES FOR ANTENNA INSTALLATIONS RECOMMENDED BY THE U.S. CONSUMER PRODUCT SAFETY COMMISSION AND LISTED IN THE ENCLOSED PAMPHLET.

Your Cushcraft antenna is designed and manufactured to give top performance and trouble free service. The antenna will perform as specified if the instructions and suggestions are followed and care is used in assembly and installation. When checking the components received in your antenna package use the parts lists in each section. It is easiest to identify the various dimensions of tubing by separating them into groups of the same diameter and length. If you are unable to locate any tube or component, check the inside of all tubing. **IMPORTANT:** save the weight label from the outside of the carton. Each antenna is weighed at the factory to verify the parts count. If you claim a missing part, you will be asked for the weight verification label. There is a master parts list on page 2.

LOCATION

Location of the antenna is very important. Surrounding objects such as trees, power lines, other antennas, etc. will seriously reduce efficiency. To minimize the effects of surrounding objects, mount the antenna as high and in the clear as possible. If metal guy wires are used, they should be broken with strain insulators. YOU MUST INSURE THAT NEITHER PEOPLE NOR PETS CAN COME IN CONTACT WITH YOUR ANTENNA WHILE IT IS IN OPERATION. DEADLY VOLTAGES AND CURRENTS MAY EXIST. ALSO, SINCE THE EFFECTS OF EXPOSURE TO RF ARE NOT FULLY UNDERSTOOD, LONG TERM EXPOSURE TO INTENSE RF FIELDS IS NOT RECOMMENDED. THERE IS A WARNING STICKER WHICH MUST BE ATTACHED TO THE BOOM AS SHOWN IN FIGURE N.

Plan your installation carefully. If you use volunteer helpers be sure that they are qualified to assist you. Make certain that everyone involved understands that you are in charge and that they must follow your instructions. If you have any doubts at all employ a professional antenna installation company to install your antenna.

MOUNTING

The mast mount bracket will accommodate up to a 2" OD (5.1 cm) mast. A 1 1/2" OD (3.8 cm) or larger heavy wall tubing mast should be used. A good heavy duty antenna rotator will provide the best service and longest life. Often it is desirable to mount several antennas on one mast. To keep possible interaction to a minimum, place your antennas as far apart as you can.

SYSTEM GROUNDING

Direct grounding of the antenna, mast and tower is very important. This serves as protection from lightning strikes and static buildup, and from high voltage which is present in the radio equipment connected to the antenna. A good electrical connection should be made to one or more ground rods (or other extensive ground system) directly at the base of the tower or mast, using at least #10 AWG ground wire and non-corrosive hardware. For details and safety standards, consult the National Electrical Code. You should also use a coaxial lightning arrester. Cushcraft offers several different models, such as LAC-1, LAC-2 and the LAC-4 series.

ASSEMBLY

Assemble your antenna by following the directions and illustrations in steps 1 through 7. After the antenna is completely assembled, verify dimensions and element spacings for accuracy. Then, return to the section below for final tuning.

TUNING PROCEDURE

The ASL2010 does not normally require tuning after assembly. If you wish to check the VSWR before installation, please observe the following procedures. Temporarily mount the antenna with the boom vertical, element 1 at least one foot off the ground on a nonmetallic support (wooden box) to prevent detuning the antenna. Guy the top of the boom with a non-conductive line. Keep other antennas and metal objects clear of the antenna under test. Do not attempt to measure the VSWR near the ground with the boom parallel to the ground since it will nullify any measurements.

Run a coax cable from your transmitter to the area in which the antenna is to be tested. The length of this feed cable is not critical. Connect a good quality VSWR meter to the end of the cable. Connect a short cable from the VSWR meter to the antenna. Set the transmitter to your center operating frequency. When you read VSWR, be sure to move far enough away from the antenna so that your body does not effect the reading.

A VSWR of 2:1 or less is sufficient and will not degrade the performance of your antenna. Repeat VSWR tests for the other bands. If VSWR is greater than 2:1, recheck all elements lengths, element position and connections.

WARNING: WHILE IT MAY BE POSSIBLE TO ADJUST THE LENGTHS OF AN ELEMENT TO IMPROVE THE VSWR ON A SINGLE BAND, DOING SO WILL DEGRADE THE GAIN AND FRONT-TO-BACK RATIO ON OTHER BANDS AND IS NOT RECOMMENDED.

MASTER PARTS LIST

KEY	PART #	DESCRIPTION	QTY	KEY	PART #	DESCRIPTION	QTY
11	010011	8-32 stainless steel hex nut	51	EA	1-1/4" x 72" (3.18 x 182.9 cm) alum tube slotted both ends	1	
33	190033	3 1/2" (8.9 cm) U-bolt backing plate	7	EB	1-1/4" x 72" (3.18 x 182.9 cm) aluminum tube assembly slotted one end	4	
40	010040	8-32 x 1/14" (3.2 cm) stainless steel machine screw	4	EC	1-1/8" x 60" (2.86 x 152.4 cm) aluminum tube assembly slotted one end	2	
50	123750	1" x 10" (2.5 x 25.4 cm) fiberglass tube	2	ED	1-1/8" x 48" (2.86 x 121.9 cm) aluminum tube assembly slotted one end	4	
51	123751	7/8" x 12" (2.22 x 30.5 cm) fiberglass tube	3	EE	7/8" x 18" (2.22 x 45.7 cm) aluminum tube slotted one end	4	
52	123752	3/4" x 10-5/8" (1.9 x 27 cm) fiberglass tube	2	EF	1-1/8" x 48" (2.86 x 121.9 cm) alum tube slotted one end	2	
53	050053	1/2" (1.27 cm) black plastic cap	16	EG	7/8" x 48" (2.22 x 121.9 cm) aluminum tube double wall slotted one end	4	
63	170063	2" (5.08 cm) machined aluminum V-block	4	EH	7/8" x 48" (2.22 x 121.9 cm) aluminum tube slotted one end	2	
70	190070	4" x 6" (10.2 x 15.2 cm) element mounting plate	1	EI	3/4" x 36" (1.9 x 91.4 cm) aluminum tube slotted one end	4	
99	050099	2" (5.1 cm) black plastic cap	2	EJ	3/4" x 48" (1.9 x 121.9 cm) aluminum tube double wall slotted one end	4	
115	050115	Connector boot	1	EK	3/4" x 36" (1.9 x 91.4 cm) aluminum tube double wall slotted one end	4	
116	240116	Silicone package	1	EL	5/8" x 36" (1.59 x 91.4 cm) aluminum tube slotted one end	6	
118	010118	5/16" (.79 cm) stainless steel hex nut	30	EM	5/8" x 24" (1.59 x 61 cm) aluminum tube slotted one end	2	
119	010119	5/16" (.79 cm) stainless steel lock washer	30	EN	1/2" x 48" (1.27 x 121.9 cm) aluminum tube	6	
123	010123	8-32 x 1.5" (3.8 cm) stainless steel machine screw	14	EO	1/2" x 36" (1.27 x 91.4 cm) aluminum tube	6	
130	190130	6" x 6" (15.24 x 15.24 cm) aluminum mounting plate	1	EP	1/2" x 24" (1.27 x 61 cm) aluminum tube	2	
156	190156	3-1/2" (8.9 cm) U-bolt bracket	7	EQ	1/2" x 18" (1.27 x 45.7 cm) aluminum tube	2	
231	010231	8-32 x 1-3/4" (4.4 cm) stainless steel machine screw	12	FL1	47-5/8" x 3/8" (121 x .9 cm) aluminum strap	2	
232	010232	8-32 x 2.5" (6.4 cm) stainless steel machine screw	3	FL2	39-1/4" x 3/8" (99.7 x .9 cm) aluminum strap	2	
326	290326	Danger label	1	FL3	34-1/8" x 3/8" (86.7 x .9 cm) aluminum strap	2	
402	013402	5/16" (.8 cm) stainless steel flat washer	8	FL4	29-9/16" x 3/8" (75.1 x .9 cm) aluminum strap	2	
403	101403	1-5/8" x 3" (4.1 x 7.6 cm) stainless steel U-bolt	2	FL5	25-3/4" x 3/8" (65.4 x .9 cm) aluminum strap	2	
404	010404	2-1/8" x 3" (5.4 x 7.6 cm) stainless steel U-bolt	6	FL6	22-7/16" x 3/8" (57 x .9 cm) aluminum strap	2	
405	010405	2" x 4" (5.1 x 10.2 cm) stainless steel U-bolt	7	FL7	19-5/8" x 3/8" (49.8 x .9 cm) aluminum strap	2	
409	030409	7/8" (2.22 cm) stainless steel worm clamp	28	FL8	10" x 3/8" (25.4 x .9 cm) formed aluminum strap	2	
411	030411	1-1/4" (3.2 cm) stainless steel worm clamp	16	MN2010	Matching network	1	
414	030414	2-1/4" (5.7 cm) stainless steel worm clamp	2				
832	323832	2" x 1-1/2" x 1/8" (5.1 x 3.8 x .3 cm) spacer	7				
941	011941	#8 stainless steel lock washer	51				
BA		2" x 75-1/4" (5.1 x 191.1 cm) swaged aluminum tube with two holes	1				
BB		2" x 72" (5.1 x 182.9 cm) aluminum tube slotted both ends	1				
BC		2" x 75-1/4" (5.1 x 191.1 cm) swaged aluminum tube with 1 hole	1				

#1 - BOOM ASSEMBLY

Slide worm clamps (414) over the slotted ends of tube BB. Insert swaged ends of tubes BA and BC into tube BB until drilled holes are aligned. Install screws (232) as shown in Figure A along with washers (941) and nut (11). Tighten all hardware. Press end caps (99) onto ends of tubes BA and BC.

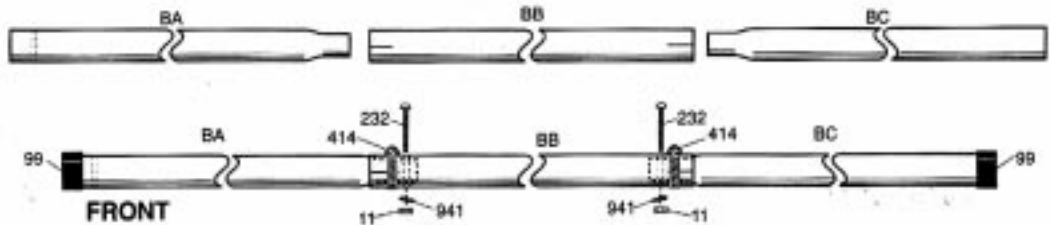

Figure A

KEY	P/N	DISPLAY	DESC	SIZE	QTY	KEY	P/N	DISPLAY	DESC	SIZE	QTY
BA			ALUM TUBE	2" x 75-1/4" (5.1 x 191.1 cm)	1	99	050099		PLASTIC CAP	2" (5.1 cm)	2
BB			ALUM TUBE	2" x 72" (5.1 x 182.9)	1	232	010232		SS MACHINE SCREW	8-32 x 2-1/2" (6.4 cm)	2
BC			ALUM TUBE	2 x 75-1/4" (5.1 x 191.1)	1	414	030414		SS WORM CLAMP	2-1/4" (5.7 cm)	2
11	010011		SS HEX NUT	#8	2	941	011941		SS LOCK WASHER	#8	2

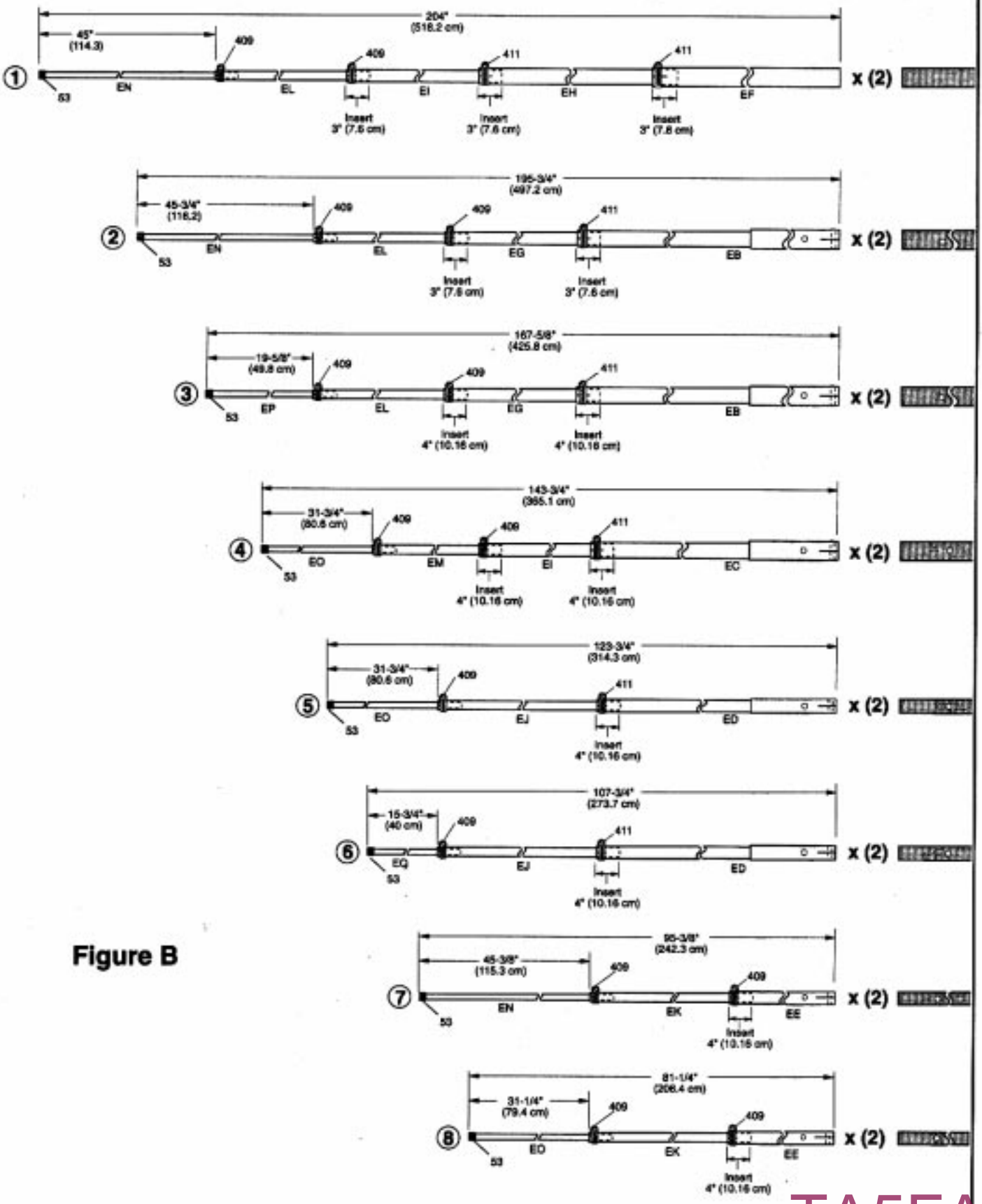

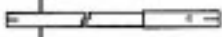

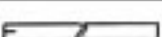
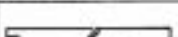
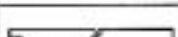
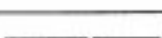



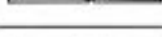
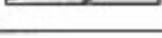
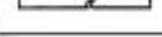

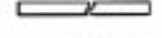





Figure B

TA5FA

#2 - ELEMENT ASSEMBLY

Sort and identify the parts for the elements. Half elements are shown in figure B. Assemble two of each of the half elements. Beginning with element 1, slide the tubes together. The lengths of tubing overlaps are shown. Insert the tip sections as necessary to achieve the called for lengths. End section dimensions are approximate. Use the worm clamps called out to secure the element sections. Note that some of the element sections are double walled. Plastic caps (53) are provided for the ends of the elements.

KEY	PIN	DISPLAY	DESC	SIZE	QTY
EB			ALUM TUBE	1-1/4" x 72" (3.2 x 182.9 cm)	4
EC			ALUM TUBE	1-1/8" x 60" (2.9 x 152.4 cm)	2
ED			ALUM TUBE	1-1/8" x 48" (2.9 x 121.9)	4
EE			ALUM TUBE	7/8" x 18" (2.2 x 45.7 cm)	4
EF			ALUM TUBE	1-1/8" x 48" 2.9 x 121.9 cm)	2
EG			ALUM TUBE DBL WALL	7/8" x 48" (2.2 x 121.9 cm)	4
EH			ALUM TUBE	7/8" x 48" (2.2 x 121.9 cm)	2
EI			ALUM TUBE	3/4" x 36" (1.9 x 91.4)	4
EJ			ALUM TUBE DBL WALL	3/4" x 48" (1.9 x 121.9)	4
EK			ALUM TUBE DBL WALL	3/4" x 36" (1.9 x 91.4 cm)	4
EL			ALUM TUBE	5/8" x 36" (1.6 x 91.4 cm)	6
EM			ALUM TUBE	5/8" x 24" (1.6 x 61 cm)	2
EN			ALUM TUBE	1/2" x 48" (1.3 x 121.9 cm)	6
EO			ALUM TUBE	1/2" x 36" (1.3 x 91.4 cm)	6
EP			ALUM TUBE	1/2" x 24" (1.3 x 61 cm)	2
EQ			ALUM TUBE	1/2" x 18" (1.3 x 45.7 cm)	2
53	050053		PLASTIC CAP	1/2" (1.3 cm)	16
409	039409		SS WORM CLAMP	7/8" (2.2 cm)	28
411	039411		SS WORM CLAMP	1-1/4" (3.2 cm)	14

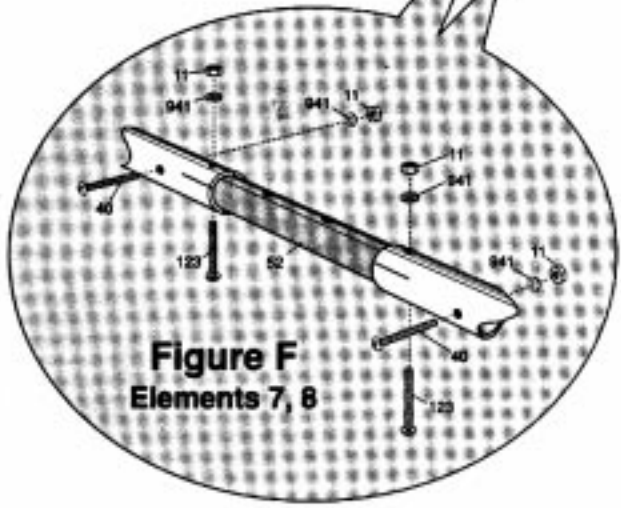
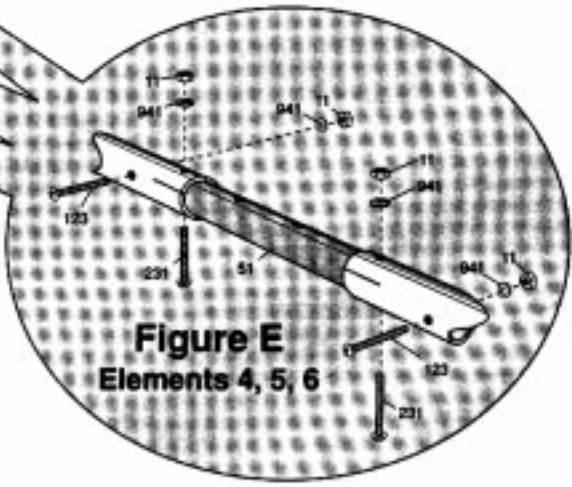
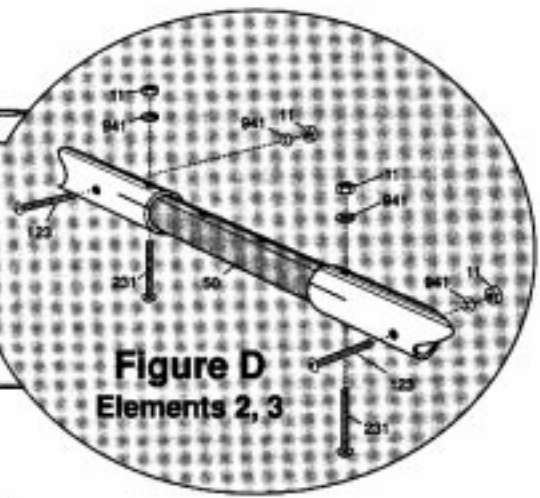
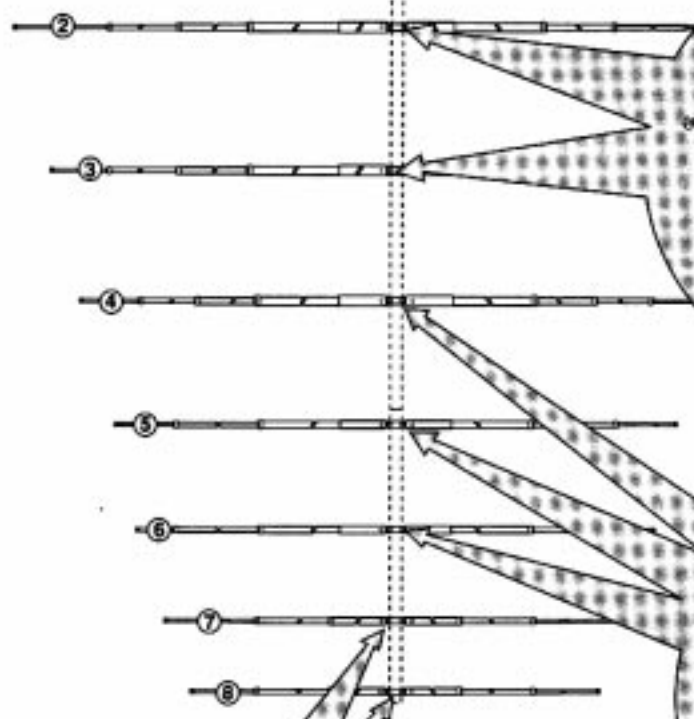
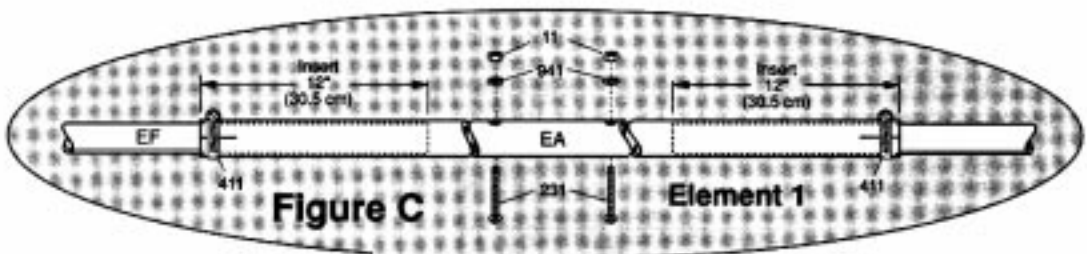

#3 - FULL ELEMENT ASSEMBLY

Element 1 is the only one without a center insulator. Assemble element 1 as shown in figure C. Note the different diameters of the fiberglass tubes. Following figures D, E and F assemble the remainder of the elements. Use care in placing the proper length screws as shown. Check that all hardware is tight.











KEY	P/N	DISPLAY	DESC	SIZE	QTY
EA			ALUM TUBE	1-1/4" x 72" (3.2 x 182.9 cm)	1
11	010011		SS HEX NUT	8-32	30
40	010040		SS MACHINE SCREW	8-32 x 1-1/4" (3.2 cm)	4
50	123750		FIBERGLASS TUBE	1" x 90" (2.5 x 25.4 cm)	2
51	123751		FIBERGLASS TUBE	7/8" X 12" (2.2 x 30.5 cm)	3
52	123752		FIBERGLASS TUBE	3/4" x 10-5/8" (1.9 x 27 cm)	2
123	010123		SS MACHINE SCREW	8-32 x 1-1/2" (3.8 cm)	14
231	010231		SS MACHINE SCREW	8-32 x 1-3/4"	12
411	030411		SS WORM CLAMP	1-1/4" (3.2 cm)	2
941	011941		SS LOCK WASHER	#8	30

Figure G



#4 - MOUNT ELEMENTS TO BOOM

Verify that each element is the proper length using figure I.

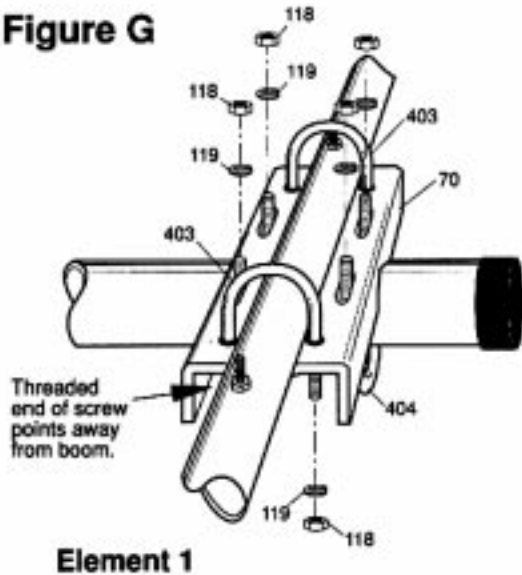
Mark the location of all element positions on the boom (figure I). The front of the boom has a hole located 1-1/2" (3.8 cm) from the end. The threaded end of the screws nearest the center of the boom must point directly away from the boom. Attach element 1 to the mounting plate as shown in figure G. Use care to center the mounting plate between the two screws and orient the screws as shown. Now center the plate on the boom over the first mark. Take care not to crush either the element or the boom when tightening the U-bolts.

The remaining elements should now be assembled as shown in figure H.

Check your assembly to this point. Are all the center screws in the elements pointing away from the boom? Are they centered and outside of the mounting plate? Are the elements the correct length and in the correct position. Are they level (all in the same plane)? Is all of the hardware tight?

Figure H

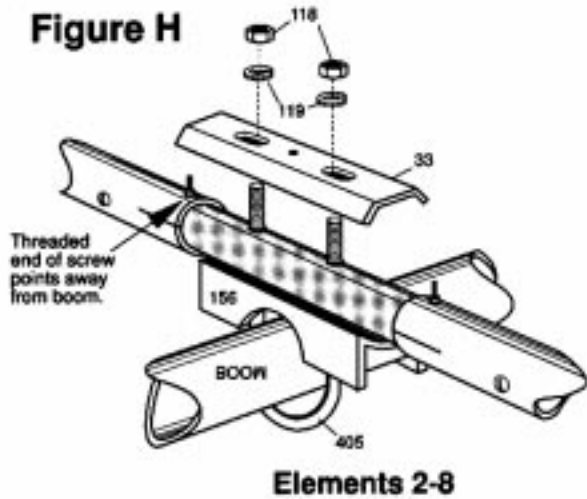



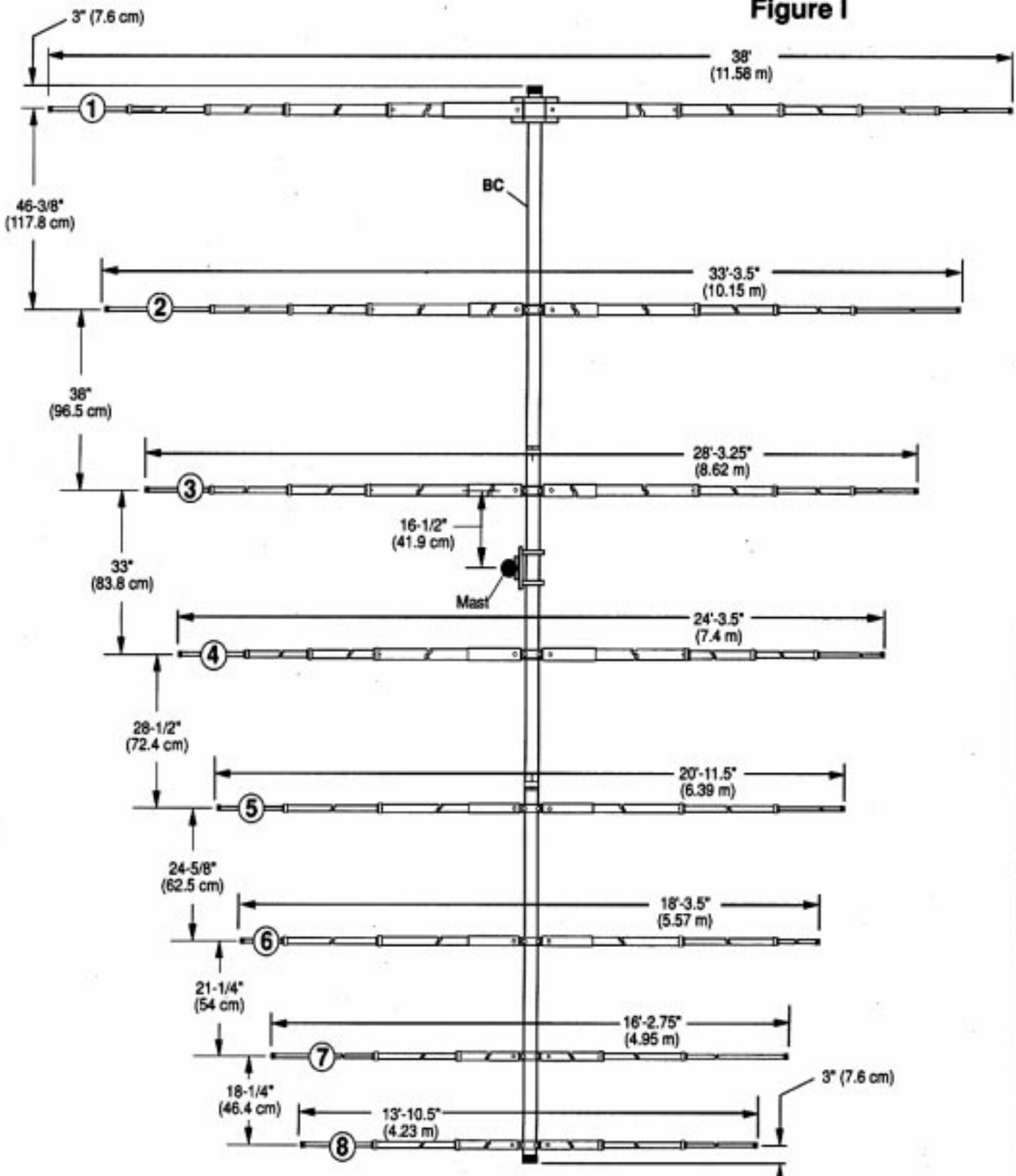

KEY	P/N	DISPLAY	DESC	SIZE	QTY
33	190033		BACKING PLATE	3-1/2" (8.9 cm)	7
70	190070		MOUNTING BRACKET	4 x 6 (10.2 x 15.2 cm)	1
118	010118		SS HEX NUT	5/16" (.8 cm)	22
119	010119		SS LOCK WASHER	5/16" (.8 cm)	22
156	190156		U-BOLT BRACKET	3-1/2" (8.9 cm)	7
403	010403		SS U-BOLT	1-5/8" x 3" (4.1 x 7.6 cm)	2
404	010404		SS U-BOLT	2-1/8" x 3" (5.4 x 7.6)	2
405	010405		SS U-BOLT	2" x 4" (5.1 x 10.2)	7

Figure I



#5 - ATTACHMENT OF FEED STRAPS

KEY	P/N	DISPLAY	DESC	SIZE	QTY
11	010011		SS HEX NUT	8-32	16
232	010232		SS MACHINE SCREW	8-32 x 2-1/2" (6.4 cm)	1
832	323832		SPACER	2" x 1-1/2" (5.1 x 3.8 cm)	7
941	011941		SS LOCK WASHER	#8	16
	MN2010		MATCHING NETWORK		1

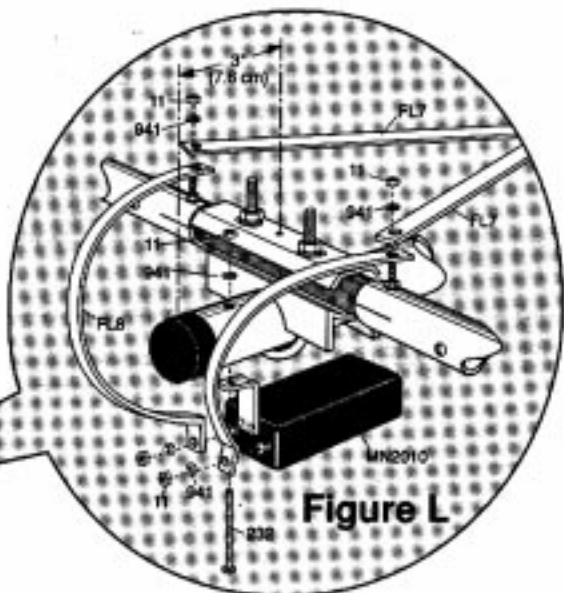
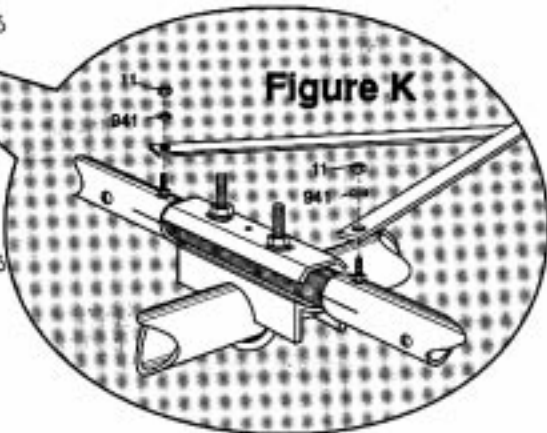
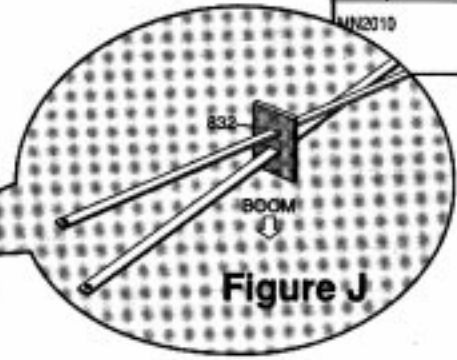
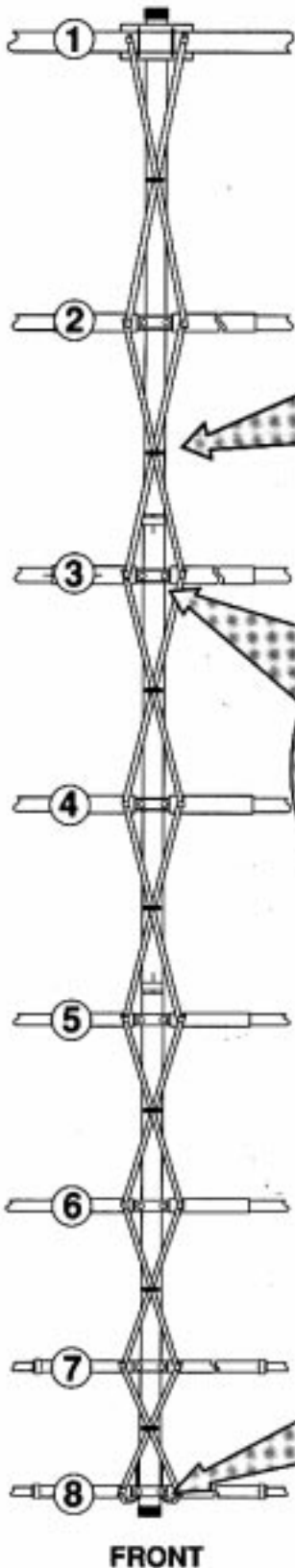

Sort by pairs and identify the feed straps by length. Slide each pair into a spacer (832) as shown in Figure J. Starting with element 1, use the longest pair to connect element 1 to element 2. Next, use the longest pair remaining to connect element 2 to element 3. Attachment details are shown in Figure K. Each set should cross between the elements. Attach the Matching Network (MN2010) to the boom as shown in Figure L and secure the formed straps (FLB) between the Matching Network and element 8. These straps do not cross. Take care that the formed straps (FLB) do not touch the mounting bracket of the matching network or boom. A 1/4" (.6 cm) space is sufficient.

#6 -ATTACH FEEDLINE

Before attaching the feedline, prepare cable and install connector boot (115) to provide a waterproof seal. Apply silicone grease (116) to the outer threads of the UHF female connector located on the matching network (MN2010). Do not coat the center pin! Thread on the male UHF connector and coat the outer sheath with the remaining grease (figure M). Slide the boot over the coax connector until it butts against the MN2010 housing.

Tape the feedline to the underside of the boom as shown. Take care not to exert any unnecessary force on the matching network. Leave a drip loop near the matching network (MN2010).

Figure M

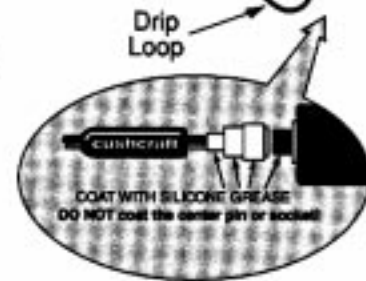

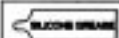
KEY	PIN	DISPLAY	DESC	SIZE	QTY
115	050115		CONN BOOT		1
116	240116		SILICONE PACKAGE		1





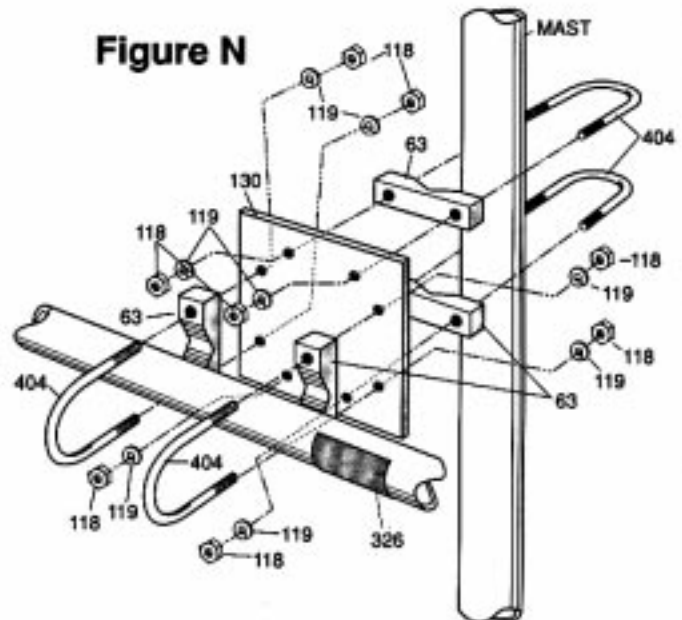

#7 -BOOM TO MAST ASSEMBLY

Refer to figure I for the location of the mast on the boom. Attach the mounting plate (130) to the boom using U-bolts (404), V-blocks (63), washer (118) and nuts (119). Once the plate is properly positioned and secured mount it to the mast using U-bolts (404), V-blocks (63), washers (118) and nuts (119). Be sure that the elements are on the top of the boom and the feedline on the bottom of the boom.

Affix danger label (326) to the boom as shown.

Figure N



KEY	PIN	DISPLAY	DESC	SIZE	QTY
63	170063		ALUM V-BLOCK	2" (5.1 cm)	4
119	010119		SS LOCK WASHER	5/16" (.8 cm)	8
118	010118		SS HEX NUT	5/16" (.8 cm)	8
130	190130		ALUM PLATE	6 x 6" (15.2 X 15.2 cm)	1
326	290326		DANGER LABEL		1
404	010404		SS U-BOLT	2-1/8 x 3" (5.4 x 7.6 cm)	4

SPECIFICATIONS

MODEL	ASL2010
Frequency, MHz	13.5-32
No. Elements	8
Forward Gain, dBd	6.4
Front to Back Ratio, dB	15-20
2:1 Bandwidth	18.5 MHz
Power Rating, Watts	2000
3 dB Beam Width, Deg. E Plane	65
Boom Length, ft (m)	18 (5.48)
Boom Diameter, in (cm)	2.0 (5.08)
Longest Element, ft (m)	38 (11.58)
Element Center Dia, in (cm)	1.25 (3.18)
Turning Radius, ft (m)	19.25 (5.86)
Mast Size Range, in (cm)	1.5-2 (3.18-5.08)
Wind Load, ft ² (m ²)	10.1 (.93)
Weight, lb (kg)	55 (25.5)

LIMITED WARRANTY

Cushcraft Corporation, P.O. Box 4680, Manchester, New Hampshire 03106, warrants to the original consumer purchaser for one year from date of purchase that each Cushcraft antenna is free of defects in material or workmanship. If, in the judgement of Cushcraft, any such antenna is defective, then Cushcraft Corporation will, at its option, repair or replace the antenna at its expense within thirty days of the date the antenna is returned (at purchaser's expense) to Cushcraft or one of its authorized representatives. This warranty is in lieu of all other expressed warranties, any implied warranty is limited in duration to one year. Cushcraft Corporation shall not be liable for any incidental or consequential damages which may result from a defect. Some states do not allow limitations on how long an implied warranty lasts or exclusions or limitations of incidental or consequential damages, so the above limitation and exclusion may not apply to you. This warranty gives you specific legal rights, and you may also have other rights which vary from state to state. This warranty does not extend to any products which have been subject to misuse, neglect, accident or improper installation. Any repairs or alterations outside of the Cushcraft factory will nullify this warranty.



48 PERIMETER ROAD, MANCHESTER, NH 03108
603-627-7877 / TELEX 4949472 / FAX 603-627-1764

SPECIFICATIONS SUBJECT TO CHANGE WITHOUT NOTICE

TA5FA