

ASSEMBLY AND INSTALLATION

A144-11

2 METER YAGI ANTENNA
144-146 MHz



951427 (8/92)

TA5FA

WARNING

THIS ANTENNA IS AN ELECTRICAL CONDUCTOR. CONTACT WITH POWER LINES CAN RESULT IN DEATH, OR SERIOUS INJURY. DO NOT INSTALL THIS ANTENNA WHERE THERE IS ANY POSSIBILITY OF CONTACT WITH OR HIGH VOLTAGE ARC-OVER FROM POWER CABLES OR SERVICE DROPS TO BUILDINGS. THE ANTENNA, SUPPORTING MAST AND/OR TOWER MUST NOT BE CLOSE TO ANY POWER LINES DURING INSTALLATION, REMOVAL OR IN THE EVENT PART OF THE SYSTEM SHOULD ACCIDENTALLY FALL. FOLLOW THE GUIDELINES FOR ANTENNA INSTALLATIONS RECOMMENDED BY THE U.S. CONSUMER PRODUCT SAFETY COMMISSION AND LISTED IN THE ENCLOSED PAMPHLET.

Your Cushcraft VHF antenna is designed and manufactured to give top performance and trouble free service. The antenna will perform as specified if the instructions and suggestions are followed and care is used in assembly and installation. When checking the components received in your antenna package use the parts lists in each section. It is easiest to identify the various dimensions of tubing by separating them into groups of the same diameter and length. If you are unable to locate any tube or component, check the inside of all tubing. *IMPORTANT: save the weight label from the outside of the carton. Each antenna is weighed at the factory to verify the parts count. If you claim a missing part, you will be asked for the weight verification label.* There is a master parts list on page 2.

LOCATION

Location of the antenna is very important. Surrounding objects such as trees, power lines, other antennas, etc. will seriously reduce efficiency. To minimize the effects of surrounding objects, mount the antenna as high and in the clear as possible. If metal guy wires are used, they should be broken with strain insulators. YOU MUST INSURE THAT NEITHER PEOPLE NOR PETS CAN COME IN CONTACT WITH YOUR ANTENNA WHILE IT IS IN OPERATION. DEADLY VOLTAGES AND CURRENTS MAY EXIST. ALSO, SINCE THE EFFECTS OF EXPOSURE TO RF ARE NOT FULLY UNDERSTOOD, LONG TERM EXPOSURE TO INTENSE RF FIELDS IS NOT RECOMMENDED. THERE IS A WARNING STICKER WHICH MUST BE ATTACHED TO THE BOOM AS SHOWN IN FIGURE E.

Plan your installation carefully. If you use volunteer helpers be sure that they are qualified to assist you. Make certain that everyone involved understands that you are in charge and that they must follow your instructions. If you have any doubts at all employ a professional antenna installation company to install your antenna.

MOUNTING

The A144-11 mast mount bracket will take up to a 1-1/2" (3.8 cm) O.D. mast. A 1-1/4" (3.17 cm) television type tubing is satisfactory for any of the *single* beams. A good heavy-duty antenna rotator will provide the best service and longest life. Often it is desirable to mount several antennas on one mast. To keep possible interaction to minimum, place your antennas as far apart as you can. Mount the A144-11 with the *Reddi-Match rods pointing up*. Keep the mast mount bracket on the opposite side of the boom from the elements. This will help to minimize pattern distortion from the mast. See page 5 for suggested dual and quad array configurations.

SYSTEM GROUNDING

Direct grounding of the antenna, mast and tower is very important. This serves as protection from lightning strikes, static buildup and high voltage which is present in the radio equipment connected to the antenna. A good electrical connection should be made to one or more ground rods (or other extensive ground system) directly at the base of the tower or mast, using at least #10AWG ground wire and non-corrosive hardware. For details and safety standards, consult the National Electrical Code. You should also use a coaxial lightning arrester. Cushcraft offers several different models, such as LAC-1, LAC-2 and the LAC-4 series.

ASSEMBLY

Assemble your antenna by following the directions and illustrations in steps 1 through 5. After the antenna is completely assembled, verify dimensions and element spacings for accuracy. Then, return to the section below for final tuning.

TUNING PROCEDURE

The A144-11 does not normally require tuning after assembly. However, if you wish to check the VSWR before installation, please observe the following procedures. To prevent detuning the antenna, it should be tuned in place or at least 7 feet (2.1 m) above ground and clear of surrounding objects. Keep all metal obstructions such as guy wires and other antennas at least 7 feet (2.1 m) away since they will nullify any adjustment and degraded performance will result.

Run the coax cable from your transmitter to the area in which the antenna is going to be tested. The length of this cable or your feedline is not critical. Connect a good quality VSWR bridge to the end of this cable. Connect a short length of cable [10 ft (3 m) or less] from the VSWR bridge to the antenna. Set the transmitter to your center operating frequency. When you read VSWR, be sure you move far enough away from the antenna so that your body does not effect the reading.

Measure the VSWR. If it is high, move the tuning strap by 1/4" (.6 cm) in one direction and check the VSWR. If the VSWR improves, then continue moving the tuning strap in the same direction. If the VSWR deteriorates then move the tuning strap in the opposite direction. Repeat this procedure until no further improvement can be made. You have matched your antenna to 50 Ohms. Tighten all connections making sure to keep the Reddi-Match assembly parallel to the element (EB) above. Tape the feedline to the boom and mast (figure G).

TA5FA

MASTER PARTS LIST

| KEY | PART # | DESCRIPTION | QUANTITY | KEY | PART # | DESCRIPTION | QUANTITY |
|-----|--------|--|----------|-----|--------|---|----------|
| 11 | 010011 | 8-32 stainless steel hex nut | 14 | 402 | 013402 | 5/16" (.8 cm) stainless steel flat washer | 4 |
| 26 | 190026 | 7/8" x 1-1/2" (2.2 x 3.8 cm) mounting bracket | 11 | 410 | 030410 | 1" (2.5 cm) stainless steel worm clamp | 2 |
| 28 | 190028 | Aluminum half washer | 10 | BA | | 1" x 48" (2.5 x 122 cm) aluminum tubing slotted both ends | 1 |
| 41 | 011941 | #8 stainless steel lock washer | 14 | BB | | 7/8" x 50" (2.2 x 127 cm) aluminum tubing | 2 |
| 45 | 321045 | Aluminum spacer | 4 | CB | | Connector bracket | 1 |
| 53 | 050053 | 1/2" (1.3 cm) black plastic cap | 2 | EA | | 40-1/4" (102.2 cm) element rod | 1 |
| 61 | 050061 | 7/8" (2.2 cm) black plastic cap | 2 | EB | | 38-7/16" (97.6 cm) element tube, drilled in center | 1 |
| 70 | 190070 | 4" x 6" (10.2 x 15.2 cm) formed mast plate | 1 | EC | | 36-3/4" (93.3 cm) element rod | 1 |
| 79 | 010079 | 8-32 x 1/2" (1.3 cm) stainless steel machine screw | 2 | ED | | 36-1/4" (92.1 cm) element rod | 1 |
| 84 | 010084 | 1/4" (.63 cm) stainless steel split lock washer | 8 | EE | | 35-3/4" (90.8 cm) element rod | 1 |
| 85 | 010085 | 1/4" (.63 cm) stainless steel hex nut | 8 | EF | | 35-1/4" (89.5 cm) element rod | 1 |
| 115 | 050115 | Connector boot | 1 | EG | | 34-3/4" (88.3 cm) element rod | 1 |
| 116 | 240116 | Silicone package | 1 | EH | | 34-1/4" (87.0 cm) element rod | 1 |
| 120 | 010120 | 8-32 x 2" (5.1 cm) stainless steel machine screw | 1 | EI | | 33-3/4" (85.7 cm) element rod | 1 |
| 125 | 200125 | Tuning strap | 1 | EJ | | 33-1/4" (84.4 cm) element rod | 1 |
| 231 | 010231 | 8-32 x 1-3/4" (4.4 cm) stainless steel machine screw | 10 | EK | | 32-3/4" (83.2 cm) element rod | 1 |
| 251 | 050251 | 3/8" (.9 cm) white plastic cap | 1 | PT | | 3/16" x 4-1/2" (.5 x 11.4 cm) Poly tube | 1 |
| 326 | 290326 | Danger label | 1 | RR | | 3/16" x 4" (.5 x 10.2 cm) Reddi-Match rod | 1 |
| 401 | 010401 | 3" x 1-3/4" (7.6 x 4.4 cm) stainless steel U-bolt | 4 | RT | | 3/8" x 6-1/2" (.9 x 16.5 cm) aluminum tube | 1 |

#1 - BOOM ASSEMBLY

Assemble the boom as shown below. Make a mark 1-3/4" (4.4 cm) in from the ends of the BB tubes as shown. Be sure to mark the correct end of the tube. Slide worm clamps (410) onto the slotted ends of tube BA. Insert both BB tubes up to the marks you made. Align the element holes and tighten the worm clamps. Push the end caps (61) onto the ends of the boom. The assembled boom is symmetrical so either end can be the front.

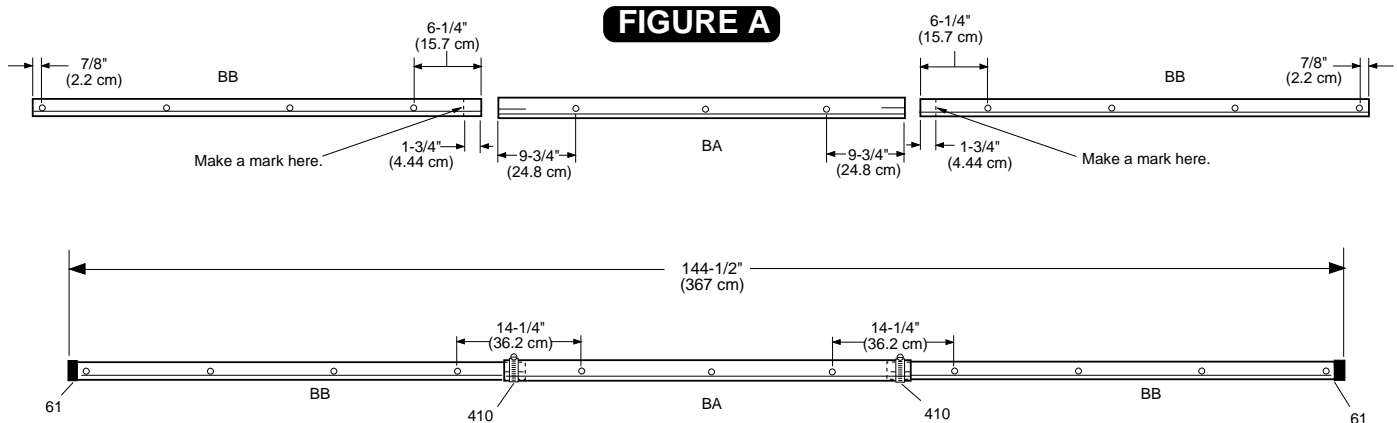

| KEY | P/N | DISPLAY | DESC | SIZE | QTY | KEY | P/N | DISPLAY | DESC | SIZE | QTY |
|-----|-----|---------|-----------|------------------------------|-----|-----|--------|---------|-------------|------------------|-----|
| BA | | | ALUM TUBE | 1" x 48" (2.5 x 122 cm) | 1 | 61 | 050061 | | PLASTIC CAP | 7/8" (2.2 cm) | 2 |
| BB | | | ALUM TUBE | 7/8" x 50" (2.2 x 127 cm) | 2 | 410 | 030410 | | WORM CLAMP | 1" (2.5 cm) | 2 |

TA5FA

#2 - ELEMENT ASSEMBLY

Slide the four pieces of the Reddi-Match assembly (PT, RR, RT, 251) together (figure B). Slide the tuning strap (125) onto the driven element (EB) and secure loosely with screws (79), nuts (11) and lock washers (41). Press on end caps (53). Slide the Reddi-Match assembly through the tuning strap. Connect the flattened rod end to the screw on the connector bracket (CB) with nut (11) and washer (41). Attach the entire driven element assembly shown below to the boom with hardware provided referring to figure D for the proper location. Slide the poly tube (PT) on the Reddi-Match assembly over the rod (RR) up to the flattened end of that rod (figure B-2). Adjust to the dimensions indicated and tighten all connections. Be sure that the connector is pointed towards the center of the boom and the Reddi-Match assembly is parallel to the element above.

Check all element lengths using table A. The cutting tolerance on these elements is $\pm 1/16"$ (.16 cm). The elements are progressively shorter as you proceed toward the front end of the boom. Attach each element to the boom per figure C referring to figure D for proper location.

TABLE A

| KEY | ELEMENT NO. | LENGTH | |
|-----|-------------|---------|-------|
| | | INCHES | CM |
| EA | 1 | 40-1/4 | 102.2 |
| EB | 2 | 38-7/16 | 97.6 |
| EC | 3 | 36-3/4 | 93.3 |
| ED | 4 | 36-1/4 | 92.1 |
| EE | 5 | 35-3/4 | 90.8 |
| EF | 6 | 35-1/4 | 89.5 |
| EG | 7 | 34-3/4 | 88.3 |
| EH | 8 | 34-1/4 | 87.0 |
| EI | 9 | 33-3/4 | 85.7 |
| EJ | 10 | 33-1/4 | 84.4 |
| EK | 11 | 32-3/4 | 83.2 |

FIGURE B

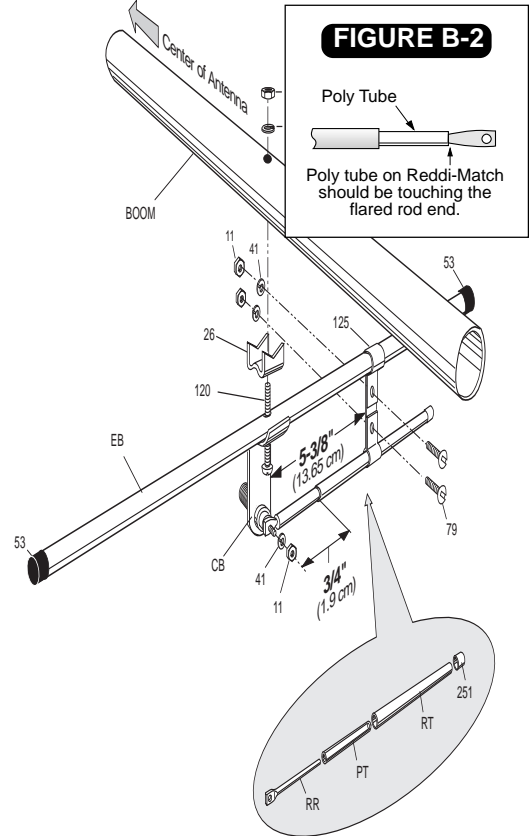
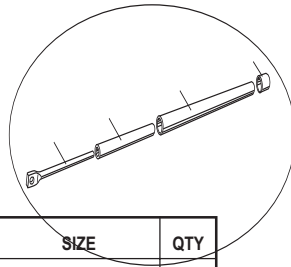

| KEY | P/N | DISPLAY | DESC | SIZE | QTY |
|-----|--------|---------|----------------------|-------------------|-----|
| 11 | 010011 | | SS HEX NUT | 8-32 | 14 |
| 26 | 190026 | | ALUMINUM BRACKET | 7/8\"/> | |
| 28 | 190028 | | ALUMINUM HALF WASHER | | 10 |
| 41 | 011941 | | SS LOCK WASHER | #8 | 14 |
| 53 | 050053 | | PLASTIC CAP | 1/2\"/> | |
| 79 | 010079 | | SS MACHINE SCREW | 8-32 x 1/2\"/> | |
| 120 | 010120 | | SS MACHINE SCREW | 8-32 x 2\"/> | |
| 125 | 200125 | | TUNING STRAP | | 1 |
| 231 | 010231 | | SS MACHINE SCREW | 8-32 x 1-3/4\"/> | |
| 251 | 050251 | | PLASTIC CAP | 3/8\"/> | |
| CB | | | CONNECTOR BRACKET | | 1 |
| EB | | | ALUMINUM TUBE | 1/2 x 38-7/16\"/> | |

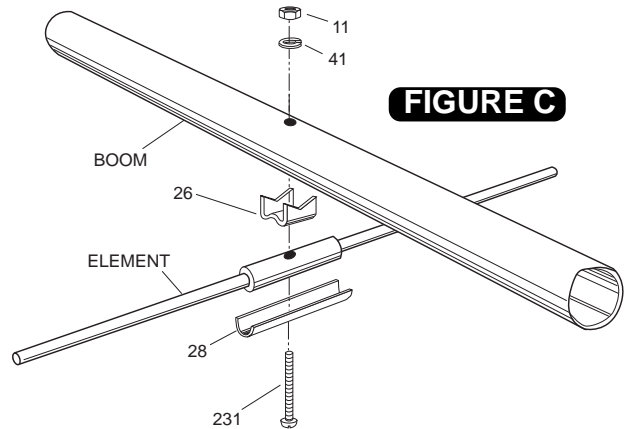
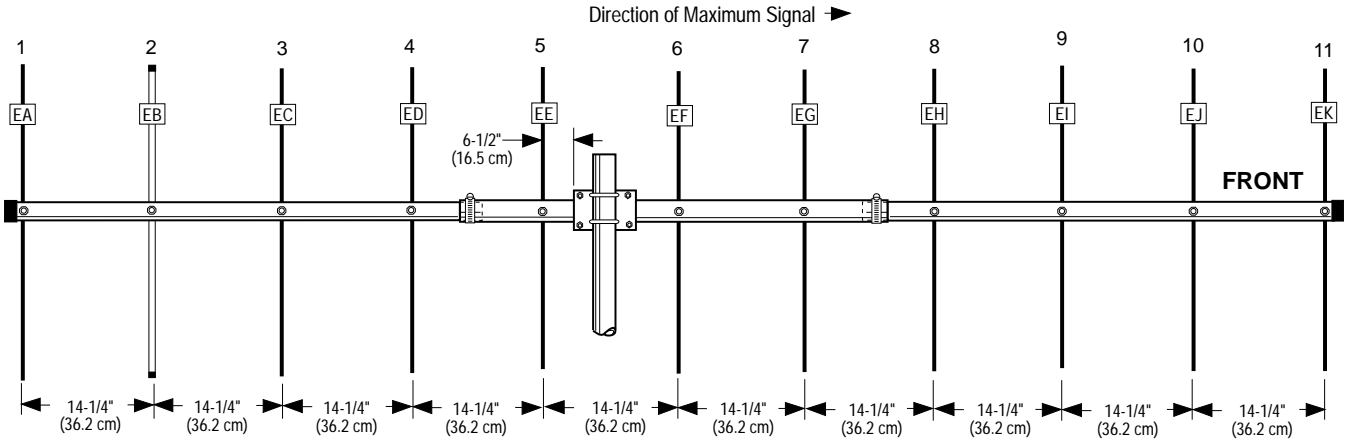

FIGURE C

| KEY | P/N | DISPLAY | DESC | SIZE | QTY |
|-----|-----|---------|-----------------|----------|-----|
| PT | | | POLY TUBE | 3/16\"/> | |
| RR | | | REDDI-MATCH ROD | 3/16\"/> | |
| RT | | | ALUMINUM TUBE | 3/8\"/> | |

TA5FA

FIGURE D



#3 - MAST MOUNT

Mount the antenna to your mast using the mounting plate (70) and the hardware provided per figure E. Refer to figure D for the balance point. Tighten the U-bolts taking care not to crush the boom.







| KEY | P/N | DISPLAY | DESC | SIZE | QTY |
|-----|--------|---|-------------------|-------------------------------|-----|
| 45 | 321045 |  | ALUMINUM SPACER | 1/2" x 1/2" (1.3 x 1.3 cm) | 4 |
| 70 | 190070 |  | FORMED MAST PLATE | 4" x 6" (10.1 x 15.2 cm) | 1 |
| 84 | 010084 |  | SS LOCK WASHER | 1/4" (.63 cm) | 8 |
| 85 | 010085 |  | SS HEX NUT | 1/4" (.63 cm) | 8 |
| 402 | 013402 |  | SS FLAT WASHER | 5/16" (.8 cm) | 4 |
| 326 | 290326 |  | DANGER LABEL | | 1 |
| 401 | 010401 |  | SS U-BOLT | 3" x 1-3/4" (7.6 x 4.4 cm) | 4 |

FIGURE E

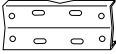

#4 - CONNECTOR ASSEMBLY

This antenna is designed for use with 50 Ohm coaxial cable terminated with a PL-259 connector. Any length of feedline can be used with your A144-11. The shortest length of cable will have the least loss. A connector boot is included for use with your new antenna. Slide the boot over the cable before attaching your PL-259 (figure F). Spread silicone on the outer threads of the Reddi-Match and PL-259 connector. **DO NOT COAT THE CENTER PINS OF THE PL-259.** Attach the connector to the Reddi-Match. Apply the remaining silicone to the outside of the connector. Slip the vinyl boot over the connector and against the mast bracket for a weather tight connection.

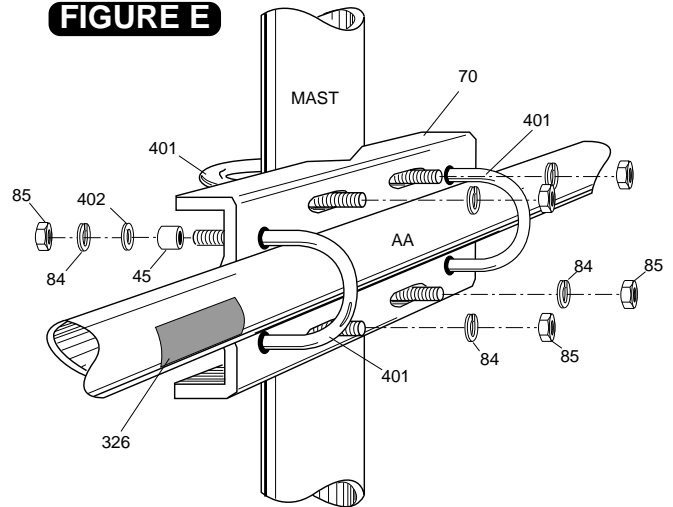

| KEY | P/N | DISPLAY | DESC | SIZE | QTY |
|-----|--------|---|------------------|------|-----|
| 115 | 050115 |  | CONN BOOT | | 1 |
| 116 | 240116 |  | SILICONE PACKAGE | | 1 |

FIGURE F



COAT WITH SILICONE GREASE
(DO NOT coat the center pin or socket!)

TA5FA

#5 - FEEDLINE

Tape your feedline along the boom and down mast (figure G). Any length of feed line can be used with your A144-11. The shortest length cable will have the least loss.

FIGURE G

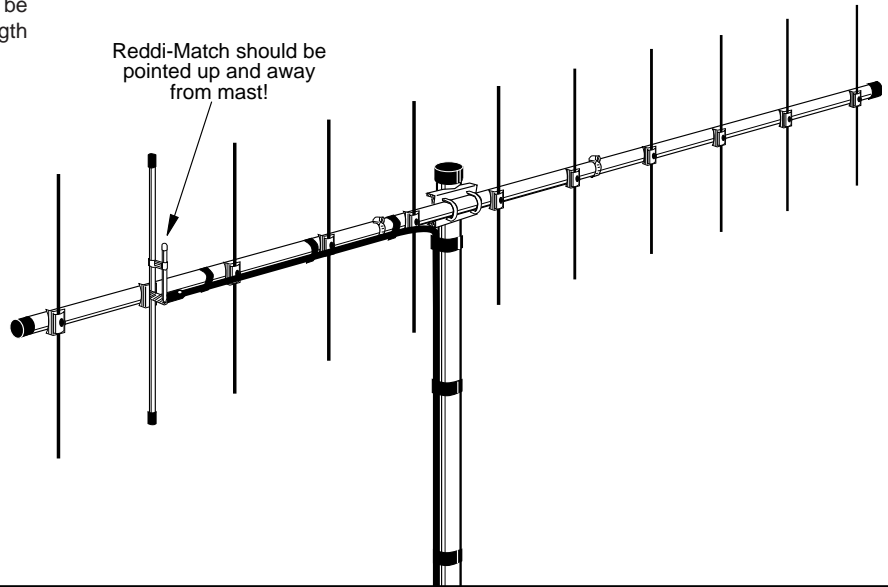

#6 - STACKING OPTIONS

The A144-11 may be stacked in arrays for increased gain and improved radiation patterns. When stacking two A144-11's use the A147-VPK stacking kit, figure H. When stacking four antennas use two A147-22 antennas and one A147-SK harness, figure I.

DUAL STACKING KIT
A14-VPK

HARNESS ONLY
A147-SK

QUAD ARRAY
(2 A147-22 & A147-SK HARNESS)

FIGURE H

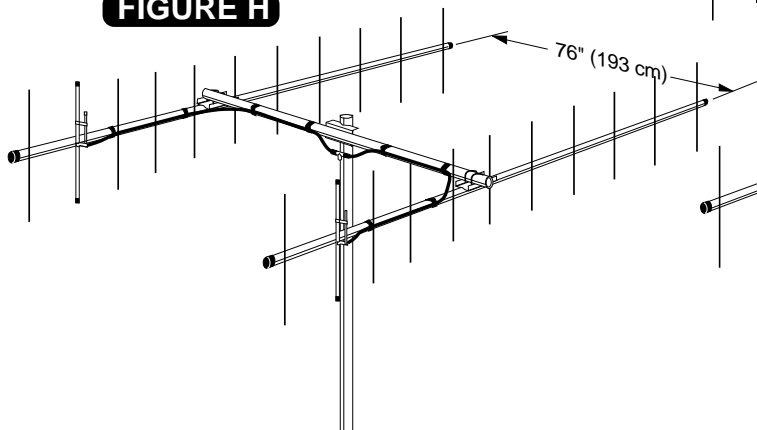
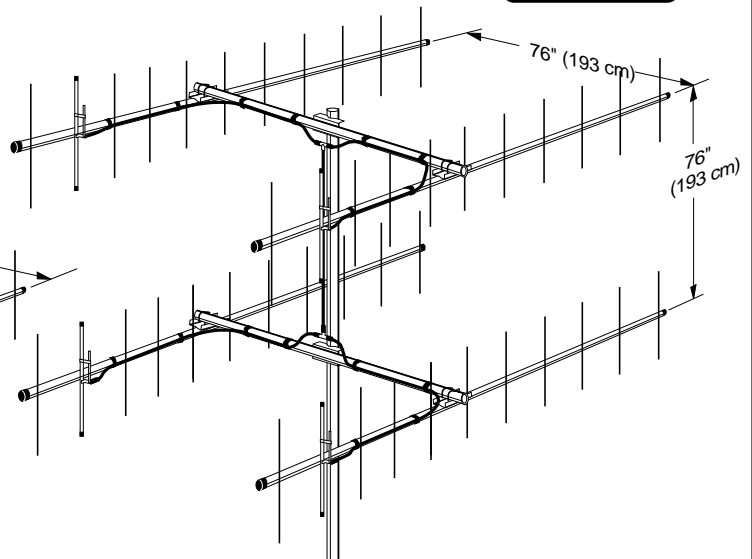

FIGURE I



TA5FA

SPECIFICATIONS

| | | | |
|--------------------------------|----------------|--|-------------|
| MODEL | A144-11 | Boom Length, ft (m) | 12 (3.6) |
| Frequency, MHz | 144-146 | Longest Element, in(cm) | 40 (101.6) |
| No. Elements | 11 | Turning Radius, ft (m) | 6.75 (2.0) |
| Forward Gain, dBd | 13.2 | Mast Size Range, in (cm) | 1.25-1.5 |
| Front to Back Ratio, dB | 20 | | (3.2-3.8) |
| SWR 1.2:1 Typical | | Wind Load, ft² (m²) | 1.21 (0.11) |
| 2:1 Bandwidth MHz | >3 | Weight, lb (kg) | 6 (2.7) |
| Power Rating, Watts PEP | 1000 | | |
| 3 dB Beamwidth, Degrees | | | |
| E Plane | 38 | | |

LIMITED WARRANTY

Cushcraft Corporation, P.O. Box 4680, Manchester, New Hampshire 03108, warrants to the original consumer purchaser for one year from date of purchase that each Cushcraft antenna is free of defects in material or workmanship. If, in the judgement of Cushcraft, any such antenna is defective, then Cushcraft Corporation will, at its option, repair or replace the antenna at its expense within thirty days of the date the antenna is returned (at purchasers expense) to Cushcraft or one of its authorized representatives. This warranty is in lieu of all other expressed warranties, any implied warranty is limited in duration to one year. Cushcraft Corporation shall not be liable for any incidental or consequential damages which may result from a defect. Some states do not allow limitations on how long an implied warranty lasts or exclusions or limitations of incidental or consequential damages, so the above limitation and exclusion may not apply to you. This warranty gives you specific legal rights, and you may also have other rights which vary from state to state. This warranty does not extend to any products which have been subject to misuse, neglect, accident or improper installation. Any repairs or alterations outside of the Cushcraft factory will nullify this warranty.



48 PERIMETER ROAD, MANCHESTER, NH 03108
603-627-7877 / TELEX 4949472 / FAX 603-627-1764

SPECIFICATIONS SUBJECT TO CHANGE WITHOUT NOTICE

TA5FA