

ASSEMBLY AND INSTALLATION



A270-6S

**2 METER/70 CM YAGI ANTENNA
144-148/430-450 MHz**



CUSHCRAFT
COMMUNICATIONS ANTENNAS

951453 (3/95)

TA5FA

WARNING

THIS ANTENNA IS AN ELECTRICAL CONDUCTOR. CONTACT WITH POWER LINES CAN RESULT IN DEATH, OR SERIOUS INJURY. DO NOT INSTALL THIS ANTENNA WHERE THERE IS ANY POSSIBILITY OF CONTACT WITH OR HIGH VOLTAGE ARC-OVER FROM POWER CABLES OR SERVICE DROPS TO BUILDINGS. THE ANTENNA, SUPPORTING MAST AND/OR TOWER MUST NOT BE CLOSE TO ANY POWER LINES DURING INSTALLATION, REMOVAL OR IN THE EVENT PART OF THE SYSTEM SHOULD ACCIDENTALLY FALL. FOLLOW THE GUIDELINES FOR ANTENNA INSTALLATIONS RECOMMENDED BY THE U.S. CONSUMER PRODUCT SAFETY COMMISSION AND LISTED IN THE ENCLOSED PAMPHLET.

Your Cushcraft VHF/UHF antenna is designed and manufactured to give top performance and trouble free service. The antenna will perform as specified if the instructions and suggestions are followed and care is used in assembly and installation. When checking the components received in your antenna package use the parts lists in each section. It is easiest to identify the various dimensions of tubing by separating them into groups of the same diameter and length. If you are unable to locate any tube or component, check the inside of all tubing. *IMPORTANT: save the weight label from the outside of the carton. Each antenna is weighed at the factory to verify the parts count. If you claim a missing part, you will be asked for the weight verification label.* There is a master parts list on page 2.

LOCATION

Location of the antenna is very important. Surrounding objects such as trees, power lines, other antennas, etc. will seriously reduce efficiency. To minimize the effects of surrounding objects, mount the antenna as high and in the clear as possible. If metal guy wires are used, they should be broken with strain insulators. YOU MUST INSURE THAT NEITHER PEOPLE NOR PETS CAN COME IN CONTACT WITH YOUR ANTENNA WHILE IT IS IN OPERATION. DEADLY VOLTAGES AND CURRENTS MAY EXIST. ALSO, SINCE THE EFFECTS OF EXPOSURE TO RF ARE NOT FULLY UNDERSTOOD, LONG TERM EXPOSURE TO INTENSE RF FIELDS IS NOT RECOMMENDED. THERE IS A WARNING STICKER WHICH MUST BE ATTACHED TO THE BOOM AS SHOWN IN FIGURE F.

Plan your installation carefully. If you use volunteer helpers be sure that they are qualified to assist you. Make certain that everyone involved understands that you are in charge and that they must follow your instructions. If you have any doubts at all employ a professional antenna installation company to install your antenna.

MOUNTING

The A270-6S mast mount bracket will take up to a 2" (5.1 cm) O.D. mast. A 1-1/4" (3.17 cm) television type tubing is satisfactory for a single A270-6S beam. A good heavy-duty antenna rotator will provide the best service and longest life. Often it is desirable to mount several antennas on one mast. To keep possible interaction to minimum, place your antennas as far apart as you can. For vertical polarization (normally FM and packet), mount the A270-6S as shown in figure G. For horizontal polarization (normally SSB and CW), mount the A270-6S with the elements parallel to the ground.

SYSTEM GROUNDING

Direct grounding of the antenna, mast and tower is very important. This serves as protection from lightning strikes, static buildup and high voltage which is present in the radio equipment connected to the antenna. A good electrical connection should be made to one or more ground rods (or other extensive ground system) directly at the base of the tower or mast, using at least #10AWG ground wire and non-corrosive hardware. For details and safety standards, consult the National Electrical Code. You should also use a coaxial lightning arrester. Cushcraft offers several different models, such as LAC-1, LAC-2 and the LAC-4 series.

ASSEMBLY

Assemble your antenna by following the directions and illustrations in steps 1 through 6. After the antenna is completely assembled, verify dimensions and element spacings for accuracy. Then, return to the section below for final tuning.

TUNING PROCEDURE

The A270-6S does not normally require tuning after assembly. **Due to the difficulty in adjusting the tuning without the proper test equipment, we do not advise adjusting either of the Reddi-Match straps. Please use the factory specified settings. An VSWR of 2:1 or less is sufficient.** However, if you wish to check the VSWR before installation, please observe the following procedures. To prevent detuning the antenna, it should be tuned in place or at least 7 feet (2.1 m) above ground and clear of surrounding objects. Keep all metal obstructions such as guy wires and other antennas at least 7 feet (2.1 m) away since they will nullify any adjustment and degraded performance will result.

Run the coax cable from your transmitter to the area in which the antenna is going to be tested. The length of this cable or your feedline is not critical. Connect a good quality VSWR bridge to the end of this cable. Connect a short length of cable [10 ft (3 m) or less] from the VSWR bridge to the antenna. Set the transmitter to your center operating frequency. When you read VSWR, be sure you move far enough away from the antenna so that your body does not effect the reading. **Note: The feedline harness (FL) must be connected to both driven elements for proper match. Do not attempt to match separately since the two driven elements interact.**

Measure the VSWR. If it is greater than 2:1, move the tuning strap for that band by 1/8" (.3 cm) in one direction and check the VSWR. If the VSWR improves, continue moving the tuning strap in the same direction. If the VSWR deteriorates then move the tuning strap in the opposite direction. Repeat this procedure until no further improvement can be made. Alternate between adjusting both 2m and 70cm until an SWR of 2:1 or better is achieved on both bands. You have matched your antenna to 50 Ohms. Note that both driven elements will have a slight interaction when adjusted for best match. Very little improvement in performance will result from a match better than 2:1 VSWR. Tighten all connections making sure to keep the Reddi-Match assembly parallel to the elements (EC & ED). Tape the feedline harness to the boom and mast (figure G).

TA5FA

MASTER PARTS LIST

KEY	PART #	DESCRIPTION	QUANTITY	KEY	PART #	DESCRIPTION	QUANTITY
9	010009	8-32 x 5/8" (1.6 cm) stainless steel machine screw	3	BA		7/8" x 33-1/2" (2.2 x 85.1 cm) aluminum tubing	1
11	010011	8-32 stainless steel hex nut	11	EA		41" (104.1 cm) element rod	1
23	190023	Connector bracket, small	1	EB		14-15/16" (37.9 cm) element rod	1
26	190026	7/8" x 1-1/2" (2.2 x 3.8 cm) mounting bracket	6	EC		1/2" x 38" (1.3 x 96.5 cm) element tube, drilled in ctr	1
28	190028	Aluminum half washer	4	ED		1/2" x 12-7/16" (1.3 x 31.6 cm) element tube, drilled in ctr	1
32	190032	3-5/8" x 2-1/2" (9.2 x 6.3 cm) U-bolt bracket	1	EE		12-1/16" (30.6 cm) element rod	1
33	190033	3-1/2" (8.9 cm) U-bolt backing plate	1	EF		36" (91.4 cm) element rod	1
41	011941	#8 stainless steel lock washer	11	FL		Feedline harness	1
43	190043	Connector bracket, large	1	RM1		5-1/2" (14 cm) Reddi-Match assembly for 2 meters	1
53	050053	1/2" (1.3 cm) black plastic cap	4	RM2		3-3/8" (8.6 cm) Reddi-Match assembly for 70 cm	1
61	050061	7/8" (2.2 cm) black plastic cap	2				
115	050115	Connector boot	1				
116	240116	Silicone package	2				
118	010118	5/16" (.8 cm) stainless steel hex nut	2				
119	010119	5/16" (.8 cm) stainless steel lock washer	2				
120	010120	8-32 x 2" (5.1 cm) stainless steel machine screw	2				
125	200125	tuning strap, large	1				
231	010231	8-32 x 1-3/4" (4.4 cm) stainless steel machine screw	4				
405	010405	5/16" x 4-1/2" x 2-7/16" (.8 x 11.4 x 6.2 cm) ss U-bolt	1				
326	290326	Danger label	1				
921	200921	Reddi-Match clamp	4				
941	360941	#8 aluminum flat washer					

#1 - BOOM ASSEMBLY

To make sure that the elements are mounted on the boom in the proper sequence it is necessary to determine the front and back of the boom (Figure A). The four larger holes are the U-bolt mounting holes and are located at the back of the boom.



KEY	P/N	DISPLAY	DESC	SIZE	QTY
BA			ALUM TUBE	7/8" x 33-1/2" (2.2 x 85.1 cm)	1
61	050061		PLASTIC CAP	7/8" (2.2 cm)	2

FIGURE A

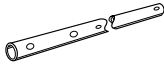

TA5FA

#2 - REDDI-MATCH ASSEMBLY

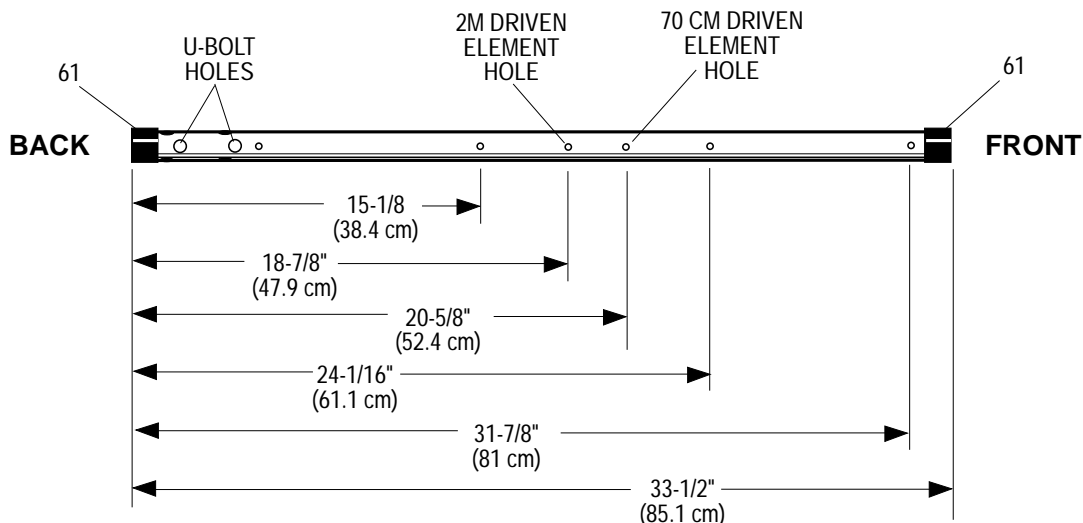
Assemble the driven element tubes (EC & ED) and connector brackets (23 & 43) to the boom at the positions shown in figure D using the hardware shown in figure B. Note that both connectors point towards the back of the boom. Attach the Reddi-Match sub-assemblies starting with element EC. Loosely attach the tuning strap (125) to the driven element (EC) as shown. Slide the longer Reddi-Match sub-assembly (RM1) through the Reddi-Match straps and secure to the connector using washer (41) and nut (11). Set the distance between the connector bracket (43) and the strap (125) as shown in figure B and tighten the hardware. Attach the other Reddi Match sub-assembly (RM2) to the other driven element (ED) using washer (41) and nut (11). Be sure to set the Reddi-Match strap dimension shown in figure B. Install end caps (53) on ends of elements EC and ED.

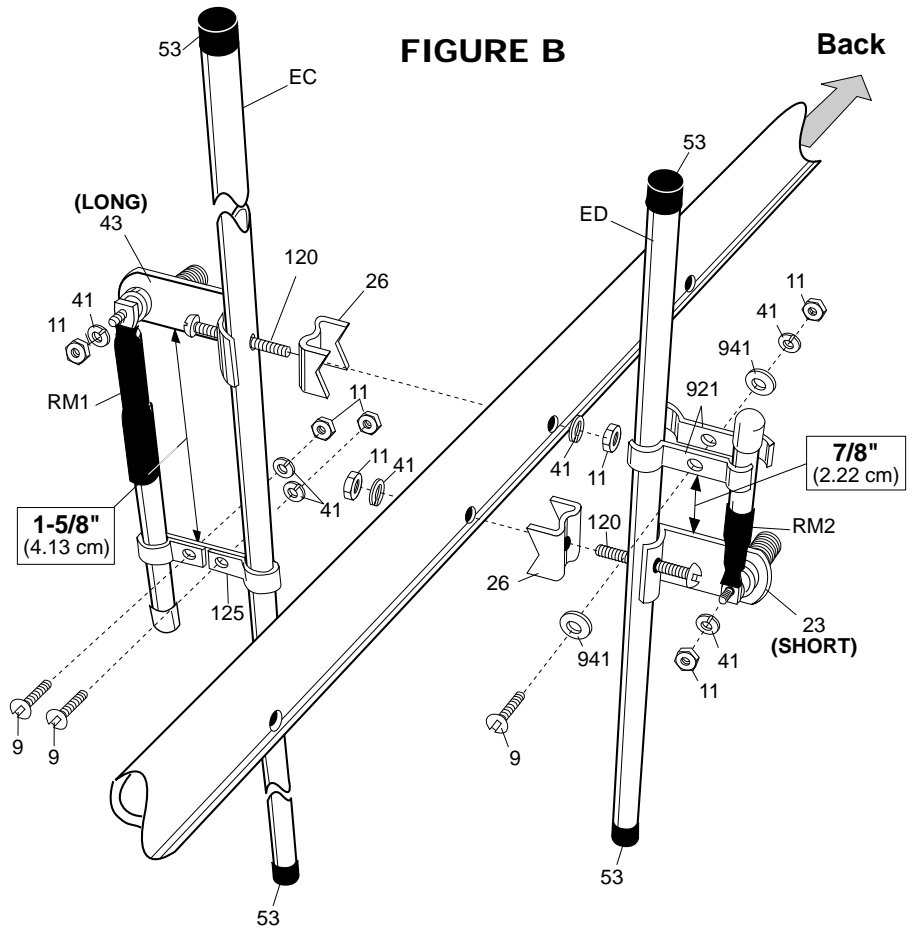

KEY	P/N	DISPLAY	DESC	SIZE	QTY	KEY	P/N	DISPLAY	DESC	SIZE	QTY
9	010009		SS MACHINE SCREW	8-32 x 5/8" (1.6 cm)	3	120	010120		SS MACHINE SCREW	8-32 x 2" (5.1 cm)	2
11	010011		SS HEX NUT	8-32	7	125	200125		TUNING STRAP		1
23	190023		CONNECTOR BRACKET	(SHORT)	1	921	200921		TUNING STRAP		2
26	190026		ALUMINUM BRACKET	7/8" (2.2 cm)	2	941	360941		ALU FLAT WASHER	#8	2
41	011941		SS LOCK WASHER	#8	7	EC			ALUMINUM TUBE	1/2" x 38" (1.3 x 96.5 cm)	1
43	190043		CONNECTOR BRACKET	(LONG)	1	ED			ALUMINUM TUBE	1/2" x 12-7/16" (1.3 x 31.6 cm)	1
53	050053		PLASTIC CAP	1/2" (1.3 cm)	4	RM1			REDDI-MATCH (2 Meter)	5-1/2" (14.0 cm))	1
						RM2			REDDI-MATCH (70 cm)	3-3/8" (8.6 cm)	1

TA5FA

FIGURE C

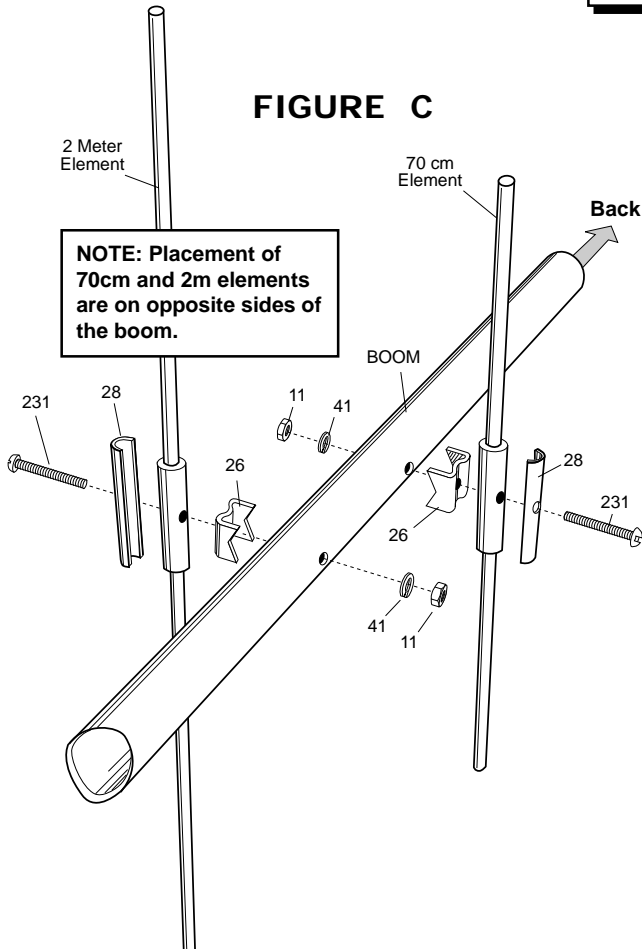

#3 - ELEMENT ASSEMBLY

Sort the elements by size using Table A. (EC and ED have already been installed.) The cutting tolerance on these elements is $\pm 1/16"$ (.16 cm). Attach each element to the boom per figure C referring to figure D for proper location.

KEY	P/N	DISPLAY	DESC	SIZE	QTY
11	010011		SS HEX NUT	8-32	4
26	190026		ALUMINUM BRACKET	7/8" (2.2 cm)	4
28	190028		ALUMINUM HALF WASHER		4
41	011941		SS LOCK WASHER	#8	4
231	010231		SS MACHINE SCREW	8-32 x 1-3/4" (4.4 cm)	4

**TABLE A
ELEMENTS**

KEY	ELEMENT NO.	LENGTH	
		INCHES	CM
EA	1	41	104.1
EB	2	14-15/16	37.9
EC	3	38	96.5
ED	4	12-7/16	31.6
EE	5	12-1/16	30.6
EF	6	36	91.4

IMPORTANT: Placement of 70cm and 2m elements and driven elements are on opposite sides of the boom.

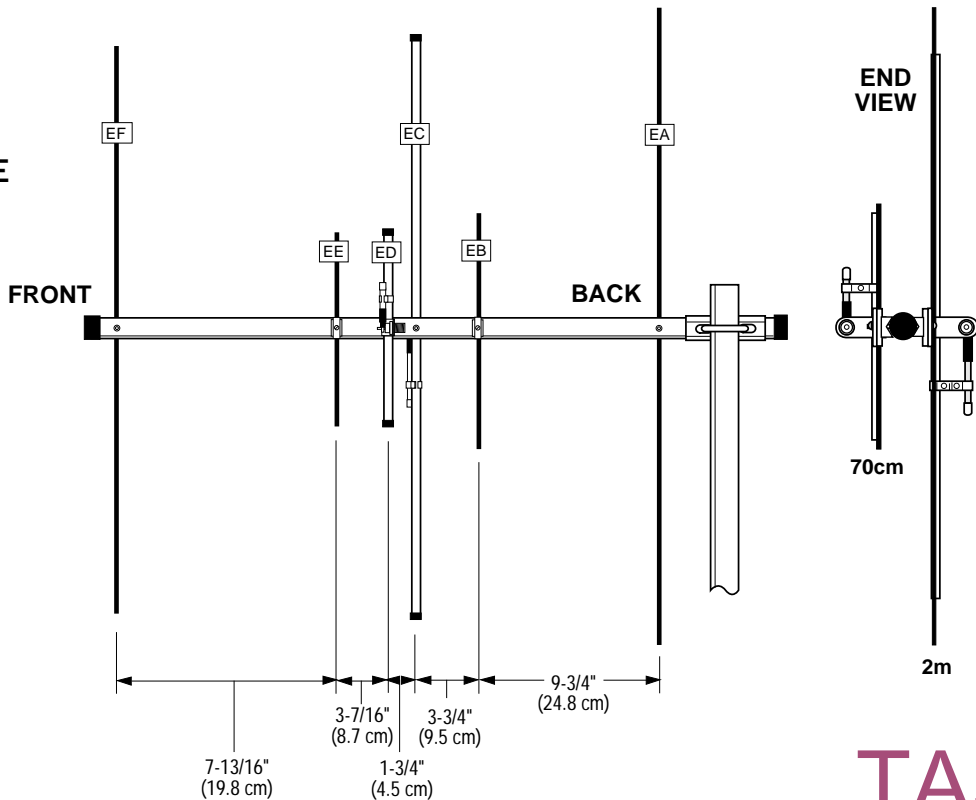

FIGURE D



TA5FA

#4 - FEEDLINE HARNESS





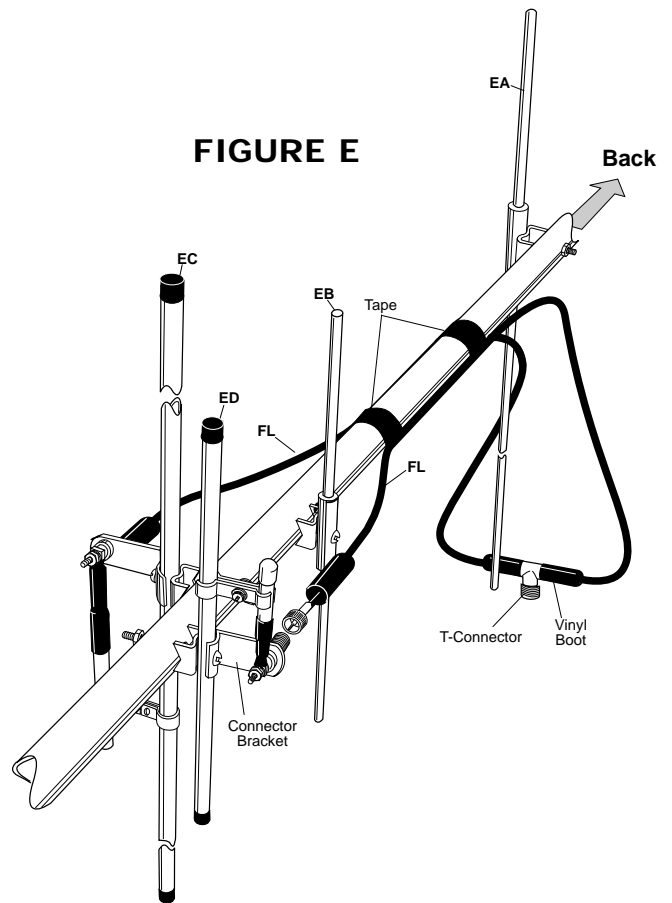
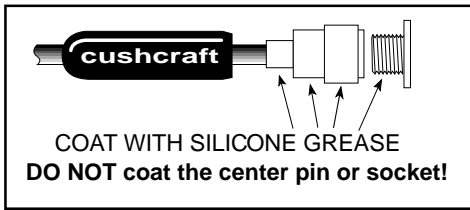

Slide back all four vinyl boots on the feedline harness (FL) to expose the male PL-259 coaxial connectors. Unthread both connectors from the coaxial T-connector. Apply silicone grease (116) to the outer threads of the in-line connectors on the T-connector and re-attach both coaxial male connectors to the T-connector. Apply silicone grease to the outer shells of both male PL-259 connectors. **Do not coat the center pin or socket of the PL-259!** Slide both vinyl boots over the connectors until they butt against the T-connector to create a waterproof seal. Coat the outer threads of both Reddi-Match connectors located on dipoles EC and ED. **Do not coat the center pin or socket of the PL-259!** Thread on both free ends of the feedline harness (FL). Note that both lengths of cable are equal. Coat outer shells of connectors with silicone grease (116). Slide both vinyl boots over the PL-259 male connectors. Make sure the boots butt against the connector brackets. Tape the feedline harness as shown (fig. E).

KEY	P/N	DISPLAY	DESC	SIZE	QTY
FL			FEEDLINE HARNESS		1
116	240116		SILICONE GREASE PACKAGE		1

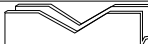

#5 - MAST MOUNT

Mount the antenna to your mast using the U-bolt bracket (32) and the hardware provided per figure E. When you tighten the U-bolt make sure not to crush the boom. Affix the warning label (326) to the boom. See "MOUNTING" on page 1 concerning orientation of mast mount, elements and Reddi-Match.

KEY	P/N	DISPLAY	DESC	SIZE	QTY
32	190032		U-BOLT BRACKET	3-5/8 x 2-1/2 (9.2 x 6.3 cm)	1
33	190033		BACKING PLATE	3-1/2" (8.9 cm)	1
118	010118		SS HEX NUT	5/16" (.8 cm)	2
119	010119		SS LOCK WASHER	5/16" (.8 cm)	2
326	290326		DANGER LABEL		1
405	010405		SS U-BOLT	5/16"x 4-1/2" x 2-7/16" (.8 x 11.4 x 6.2 cm)	1

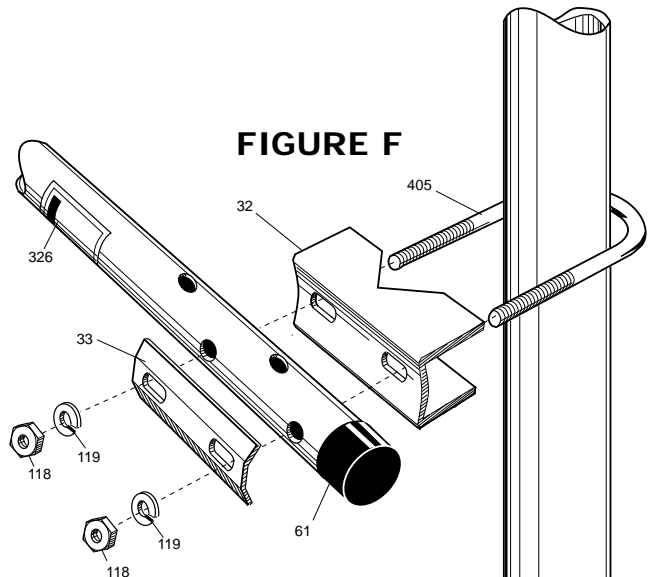

TA5FA

#6 - FEEDLINE

Tape your feedline down the mast (figure G). Any length of feedline can be used with your A270-6S. The shortest length cable will have the least loss. Before installing your connector, slide boot (115) over your feedline. Now, coat the outer threads of the T-connector with silicone grease (116). Do not coat center pin. Thread PL-259 connector onto T-connector. Apply silicone grease over outside shell of PL-259. Slide boot over PL-259 until it butts against the T-connector for a waterproof seal.

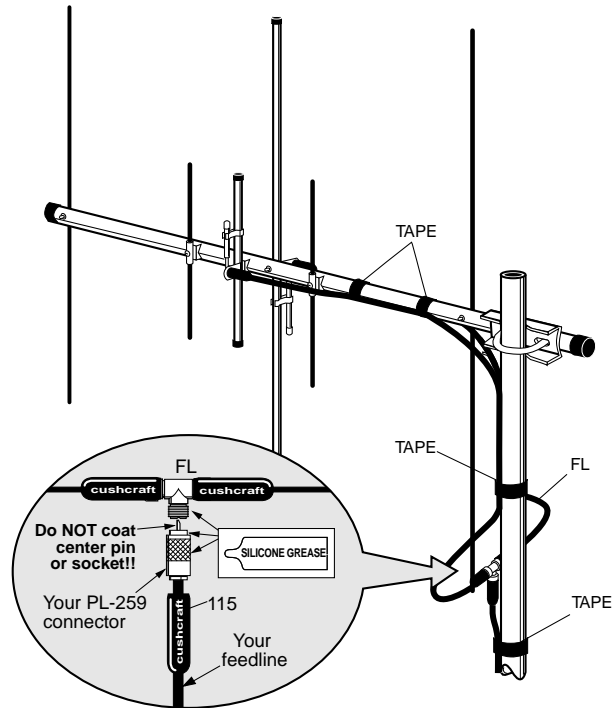

FIGURE G

KEY	P/N	DISPLAY	DESC	SIZE	QTY
115	050115		CONN BOOT		1
116	240116		SILICONE PACKAGE		1

SPECIFICATIONS			
MODEL	A270-6S	Boom Length, ft (m)	2.8 (.85)
Frequency, MHz	144-148	Longest Element, in(cm)	41 (104.1)
	430-450	Turning Radius, ft (m)	2.8 (.85)
No. Elements	3/3	Mast Size Range, in (cm)	1.25-2.0 (3.2-5.1)
Forward Gain, dB	7.8/7.8	Wind Load, ft ² (m ²)	.3 (.02)
Front to Back Ratio, dB	20/18	Weight, lb (kg)	1.7 (.8)
SWR 1.2:1 Typical			
2:1 Bandwidth MHz	≥4 / ≥20		
Power Rating, Watts PEP	350 / 350		
3 dB Beamwidth, Degrees			
	E Plane	66 / 66	
	H Plane	108 / 108	

LIMITED WARRANTY

Cushcraft Corporation, P.O. Box 4680, Manchester, New Hampshire 03108, warrants to the original consumer purchaser for one year from date of purchase that each Cushcraft antenna is free of defects in material or workmanship. If, in the judgement of Cushcraft, any such antenna is defective, then Cushcraft Corporation will, at its option, repair or replace the antenna at its expense within thirty days of the date the antenna is returned (at purchasers expense) to Cushcraft or one of its authorized representatives. This warranty is in lieu of all other expressed warranties, any implied warranty is limited in duration to one year. Cushcraft Corporation shall not be liable for any incidental or consequential damages which may result from a defect. Some states do not allow limitations on how long an implied warranty lasts or exclusions or limitations of incidental or consequential damages, so the above limitation and exclusion may not apply to you. This warranty gives you specific legal rights, and you may also have other rights which vary from state to state. This warranty does not extend to any products which have been subject to misuse, neglect, accident or improper installation. Any repairs or alterations outside of the Cushcraft factory will nullify this warranty.



**48 PERIMETER ROAD, MANCHESTER, NH 03108
603-627-7877 / FAX 603-627-1764**

SPECIFICATIONS SUBJECT TO CHANGE WITHOUT NOTICE

TA5FA