

# A430-11S

**70 CENTIMETER YAGI ANTENNA  
430-435 MHz**



951426 (7/93)

TA5FA

**WARNING**

THIS ANTENNA IS AN ELECTRICAL CONDUCTOR. CONTACT WITH POWER LINES CAN RESULT IN DEATH OR SERIOUS INJURY. DO NOT INSTALL THIS ANTENNA WHERE THERE IS ANY POSSIBILITY OF CONTACT WITH OR HIGH VOLTAGE ARC-OVER FROM POWER CABLES OR SERVICE DROPS TO BUILDINGS. THE ANTENNA, SUPPORTING MAST AND/OR TOWER MUST NOT BE CLOSE TO ANY POWER LINES DURING INSTALLATION, REMOVAL OR IN THE EVENT PART OF THE SYSTEM SHOULD ACCIDENTALLY FALL. FOLLOW THE GUIDELINES FOR ANTENNA INSTALLATIONS RECOMMENDED BY THE U.S. CONSUMER PRODUCT SAFETY COMMISSION AND LISTED IN THE ENCLOSED PAMPHLET.

Your Cushcraft A430-11S antenna is designed and manufactured to give top performance and trouble free service. The antenna will perform as specified if the instructions and suggestions are followed and care is used in assembly and installation. When checking the components received in your antenna package use the parts lists in each section. It is easiest to identify the various dimensions of tubing by separating them into groups of the same diameter and length. If you are unable to locate any tube or component, check the inside of all tubing. **IMPORTANT:** save the weight label from the outside of the carton. Each antenna is weighed at the factory to verify the parts count. If you claim a missing part, you will be asked for the weight verification label. There is a master parts list on page 2.

**LOCATION**

Location of the antenna is very important. Surrounding objects such as trees, power lines, other antennas, etc. will seriously reduce efficiency. To minimize the effects of surrounding objects, mount the antenna as high and in the clear as possible. If metal guy wires are used, they should be broken with strain insulators. YOU MUST INSURE THAT NEITHER PEOPLE NOR PETS CAN COME IN CONTACT WITH YOUR ANTENNA WHILE IT IS IN OPERATION. DEADLY VOLTAGES AND CURRENTS MAY EXIST. ALSO, SINCE THE EFFECTS OF EXPOSURE TO RF ARE NOT FULLY UNDERSTOOD, LONG TERM EXPOSURE TO INTENSE RF FIELDS IS NOT RECOMMENDED. THERE IS A WARNING STICKER WHICH MUST BE ATTACHED TO THE BOOM AS SHOWN IN FIGURE E.

Plan your installation carefully. If you use volunteer helpers be sure that they are qualified to assist you. Make certain that everyone involved understands that you are in charge and that they must follow your instructions. If you have any doubts at all employ a professional antenna installation company to install your antenna.

**MOUNTING**

The A430-11S mast mount bracket will take up to a 1-3/4" (4.4 cm) O.D. mast. A 1-1/4" (3.17 cm) television type tubing is satisfactory for any of the single beams. A good heavy-duty antenna rotator will provide the best service and longest life. Often it is desirable to mount several antennas on one mast. To keep possible interaction to minimum, place your antennas as far apart as you can. Mount the A430-11S with the Reddi-Match rod pointing up. Keep the mast mount bracket on the opposite side of the boom from the elements. This will help to minimize pattern distortion from the mast. See page 5 for dual array configuration.

**SYSTEM GROUNDING**

Direct grounding of the antenna, mast, and tower is very important. This provides protection from lightning strikes, static buildup, and high voltage which is present in the radio equipment connected to the antenna. A good electrical connection should be made to one or more ground rods (or other extensive ground system) directly at the base of the tower or mast, using at least #10 AWG ground wire and non-corrosive hardware. For details and safety standards, consult the National Electrical Code. You should also use a coaxial lightning arrester. Cushcraft offers several different models, such as LAC-1, LAC-2, and the LAC-4 series.

**ASSEMBLY**

Assemble your antenna by following the directions and illustrations in steps 1 through 5. After the antenna is completely assembled, verify dimensions and element spacings for accuracy. Then, return to the section below for final tuning.

**TUNING PROCEDURE**

The A430-11S does not normally require tuning after assembly. However, if you wish to check the VSWR before installation, please observe the following procedures. To prevent detuning the antenna, it should be tuned in place or at least 7 feet (2.1 m) above ground and clear of surrounding objects. Keep all metal obstructions such as guy wires and other antennas at least 7 feet (2.1 m) away since they will nullify any adjustment and degraded performance will result.

Run the coax cable from your transmitter to the area in which the antenna is going to be tested. The length of this cable or your feedline is not critical. Connect a good quality VSWR bridge to the end of this cable. Connect a short length of cable [10 ft (3 m) or less] from the VSWR bridge to the antenna. Set the transmitter to your center operating frequency. When you read VSWR, be sure you move far enough away from the antenna so that your body does not effect the reading.

Measure the VSWR. If it is high, move the Reddi-Match clamp by 1/4" (.6 cm) in one direction and check the VSWR. If the VSWR improves, then continue moving the Reddi-Match clamp in the same direction. If the VSWR deteriorates then move the Reddi-Match clamp in the opposite direction. Repeat this procedure until no further improvement can be made. You have matched your antenna to 50 Ohms. Tighten all connections making sure to keep the Reddi-Match assembly parallel to the element (EB) above. Tape the feedline to the boom and mast (figure G).

# MASTER PARTS LIST

KEY	PART #	DESCRIPTION	QUANTITY	KEY	PART #	DESCRIPTION	QUANTITY
11	010011	8-32 stainless steel hex nut	13	921	200921	Reddi-Match clamp	2
26	190026	7/8" x 1-1/2" (2.2 x 3.8 cm) mounting bracket	11	941	360941	#8 aluminum flat washer	2
28	190028	Aluminum half washer	10	BA		1" x 55" (2.5 x 139.7 cm) aluminum tubing drilled 15 places	1
32	190032	3-5/8" x 2-1/2" (9.2 x 6.3 cm) U-bolt bracket	1	CB		Connector bracket	1
38	050038	1" (2.5 cm) black plastic cap	2	EA		13-3/4" (34.9 cm) element rod	1
41	011941	#8 stainless steel lock washer	14	EB		12-7/8" x 1/2" (32.7 x 1.3 cm) aluminum element tube	1
53	050053	1/2" (1.3 cm) black plastic cap	2	EC		12-1/4" (31.1 cm) element rod	1
79	010079	8-32 x 1/2" (1.3 cm) stainless steel machine screw	1	ED		12-1/8" (30.8 cm) element rod	1
84	010084	1/4" (.63 cm) stainless steel split lock washer	2	EE		12" (30.5 cm) element rod	1
85	010085	1/4" (.63 cm) stainless steel nut	2	EF		11-7/8" (30.2 cm) element rod	1
115	050115	Connector boot	1	EG		11-3/4" (29.8 cm) element rod	1
116	240116	Silicone package	1	EH		11-5/8" (29.5 cm) element rod	1
231	010231	8-32 x 1-3/4" (4.4 cm) stainless steel machine screw	10	EI		11-1/2" (29.2 cm) element rod	1
232	010232	8-32 x 2-1/2" (6.5 cm) stainless steel machine screw	1	EJ		11-3/8" (28.9 cm) element rod	1
251	050251	3/8" (.9 cm) white plastic cap	1	EK		11-1/8" (28.3 cm) element rod	1
326	290326	Danger label	1	PT		3/16" x 2-1/2" (.5 x 6.3 cm) poly tube	1
402	010402	3-3/4" x 1-3/4" (9.5 x 4.4 cm) stainless steel U-bolt	1	RR		3/16" x 1-5/8" (.5 x 4.1 cm) Reddi-Match rod	1
720	190720	7/8" x 3/8" (2.2 x .9 cm) backing plate	1	RT		3/8" x 2-3/4" (.9 x 7.0 cm) aluminum tube	1

## #1 - BOOM ASSEMBLY

To make sure that the elements are mounted on the boom in the proper sequence it is necessary to determine the front and back of the boom (figure A). The larger U-bolt mounting holes are not in the center of the boom. There are six element holes on one side of the U-bolt mount holes and five on the other. The driven element will be mounted on the side with 6 holes which is the back of the boom. Press end caps onto the ends of the boom.

FIGURE A

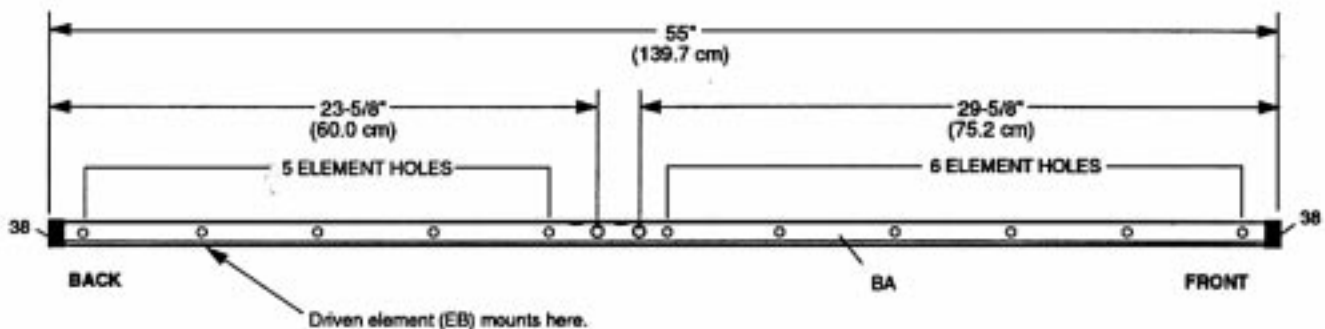

KEY	P/N	DISPLAY	DESC	SIZE	QTY
BA			ALUM TUBE	1" x 53" (2.5 x 134.6 cm)	1
38	050038		PLASTIC CAP	1" (2.5)	2













## #2 - ELEMENT ASSEMBLY

Slide the four pieces of the Reddi-Match assembly (PT, RR, RT, 251) together (figure B). Assemble the tuning strap onto the element tube (EB) using the two Reddi-Match clamps (921), lock washers (41), flat washers (941), and hex nut (11). Slide the Reddi-Match assembly through the tuning clamp assembly. Connect the flattened rod end to the screw on the connector bracket (CB) with nut (11) and washer (41). Attach the entire driven element assembly shown below to the boom with hardware provided. Refer to figure D for the proper location. Slide the poly tube (PT) in the Reddi-Match assembly over the rod (RR) up to the flattened end of that rod (figure B-2). Adjust to the dimensions indicated and tighten all connections. Be sure that the connector is pointed towards the center of the boom and the Reddi-Match assembly is parallel to the element above. Press on end caps (53).



Check all element lengths using table A. The cutting tolerance on these element is  $\pm 1/16"$  (.16 cm). The elements are progressively shorter as you proceed towards the front end of the boom. Attach each element to the boom per figure C referring to figure D for proper location.

TABLE A

KEY	ELEMENT NO.	LENGTH	
		INCHES	CM
EA	1	13-3/4	34.9
EB	2	12-7/8	32.7
EC	3	12-1/4	31.1
ED	4	12-1/8	30.8
EE	5	12	30.5
EF	6	11-7/8	30.2
EG	7	11-3/4	29.8
EH	8	11-5/8	29.5
EI	9	11-1/2	29.2
EJ	10	11-3/8	28.9
EK	11	11-1/8	28.3

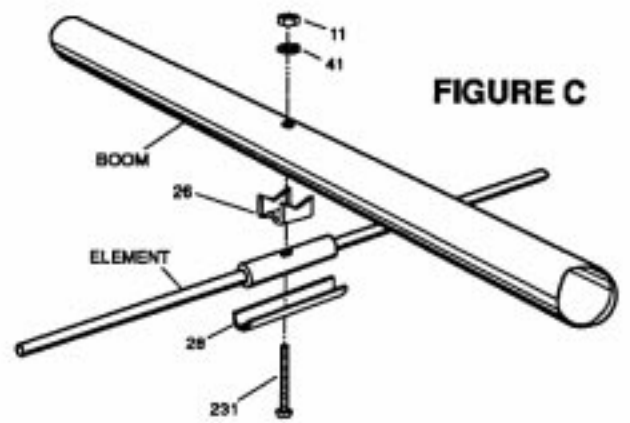
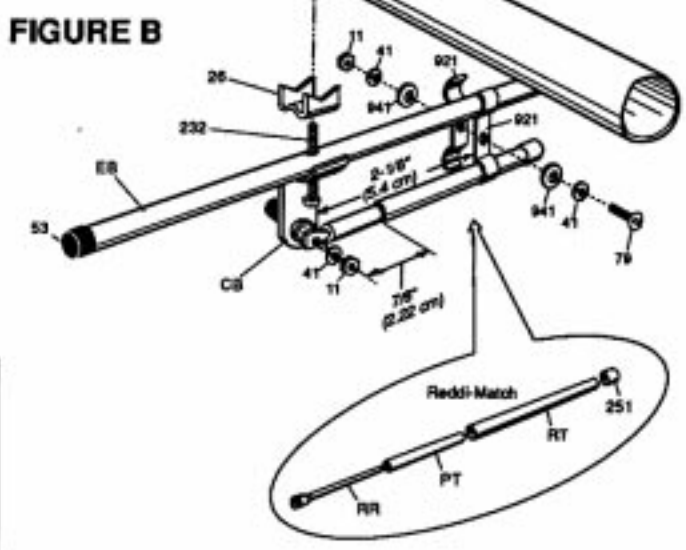
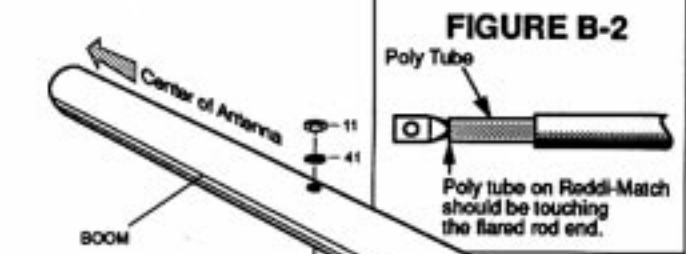
KEY	P/N	DISPLAY	DESC	SIZE	QTY
11	010011		SS HEX NUT	6-32	13
26	190026		ALUMINUM BRACKET	7/8" (2.2 cm)	11
28	190028		ALUMINUM HALF WASHER		10
41	011941		SS LOCK WASHER	#6	14
53	050253		PLASTIC CAP	1/2" (1.3 cm)	2
79	010079		SS MACHINE SCREW	8-32 x 1/2" (1.3 cm)	1
231	010231		SS MACHINE SCREW	8-32 x 1-3/4" (4.4 cm)	10
232	010232		SS MACHINE SCREW	8-32 x 2-1/2" (6.3 cm)	1
251	050251		PLASTIC CAP	3/8" (.9 cm)	1
921	200921		REDDI-MATCH CLAMP		2
941	360941		FLAT WASHER	#6	2
CB			CONNECTOR BRACKET ASS'Y		1
EB			ALUMINUM TUBE	1/2 x 12-3/8" (1.3 x 31.4 cm)	1



KEY	P/N	DISPLAY	DESC	SIZE	QTY
PT			POLY TUBE	3/16" x 2-1/2" (.5 x 6.3 cm)	1
RR			REDDI-MATCH ROD	3/16" x 1-5/8" (.5 x 4.1 cm)	1
RT			ALUMINUM TUBE	3/8" x 2-3/4" (.9 x 7.0 cm)	1

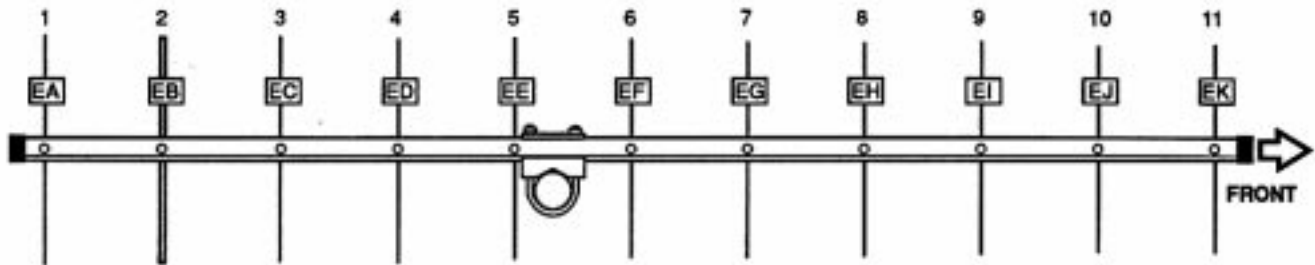

FIGURE D

### #3 - MAST MOUNT

Mount the antenna to your mast using the U-bolt bracket (32) and the hardware provided per figure E. Tighten the U-bolt taking care not to crush the boom. Affix warning label to the boom as shown.

KEY	P/N	DISPLAY	DESC	SIZE	QTY
32	190032		U-BOLT BRACKET		1
84			SS LOCK WASHER	1/4" (.83 cm)	2
85			SS HEX NUT	1/4" (.83 cm)	2
326	290326		DANGER LABEL		1
402	010402		SS U-BOLT	3-3/4" x 1-3/4" (9.5 x 4.4 cm)	1
720	190720		BACKING PLATE	7/8" x 3/8" (2.2 x .9 cm)	1

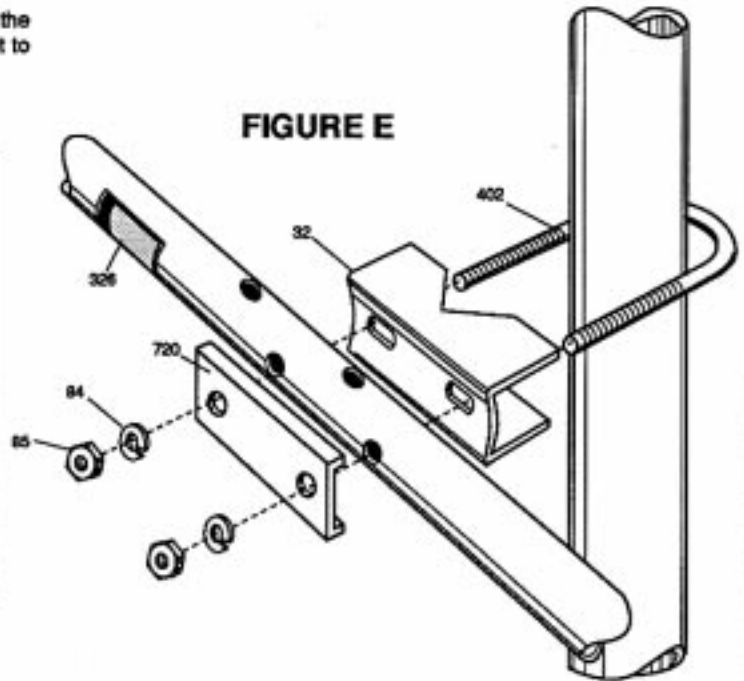

FIGURE E

### #4 - CONNECTOR ASSEMBLY

This antenna is designed for use with 50 Ohm coaxial cable terminated with a PL-259 connector. Any length of feedline can be used with your A430-11S. The shortest length of cable will have the least loss. A connector boot is included for use with your new antenna. Slide the boot over the cable before attaching your PL-259 (figure F). Spread silicone on the outer threads of the Reddi-Match connector and PL-259 connector. DO NOT COAT THE CENTER PIN OF THE PL-259. Attach the connector to the Reddi-Match. Apply the remaining silicone to the outside of the connector. Slip the vinyl boot over the connector and against the connector bracket for a weathertight connection.

KEY	P/N	DISPLAY	DESC	SIZE	QTY
115	050115		CONNECTOR BOOT		1
116	240116		SILICONE PACKAGE		1



FIGURE F

## #5 - FEED LINE

Tape your feedline along the boom and down the mast (figure G). Any length of feed line can be used with your A430-11S. The shortest length cable will have the least loss. It's a good idea to form a drip loop in the coax to help protect the connector from water damage (figure H).

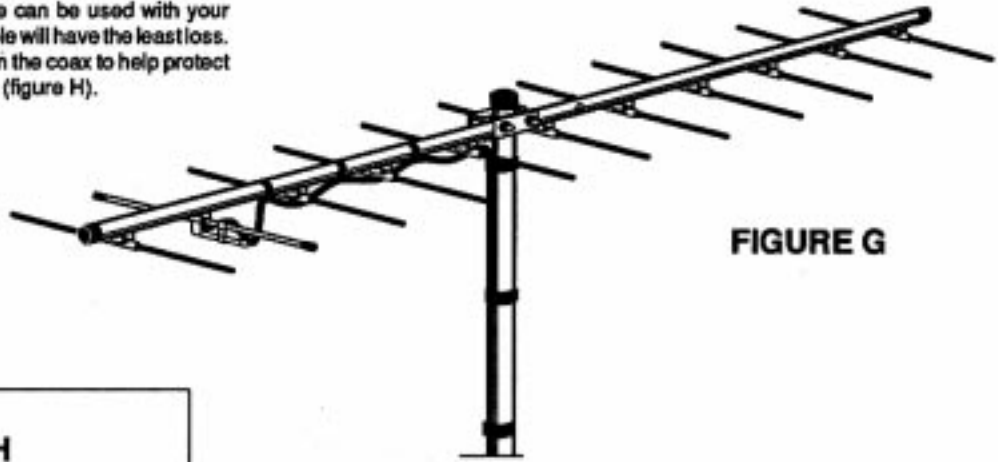

FIGURE G

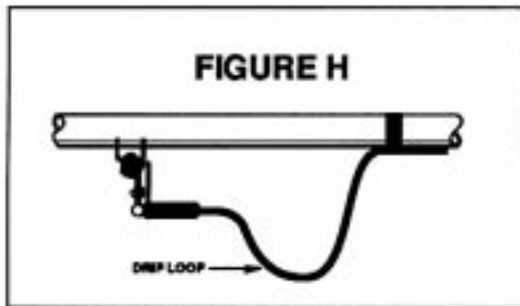

FIGURE H

## #6 - STACKING

The A430-11S may be stacked in arrays for improved radiation patterns and increased gain. When stacking 2 antennas use the Cushcraft A41-SK stacking harness.

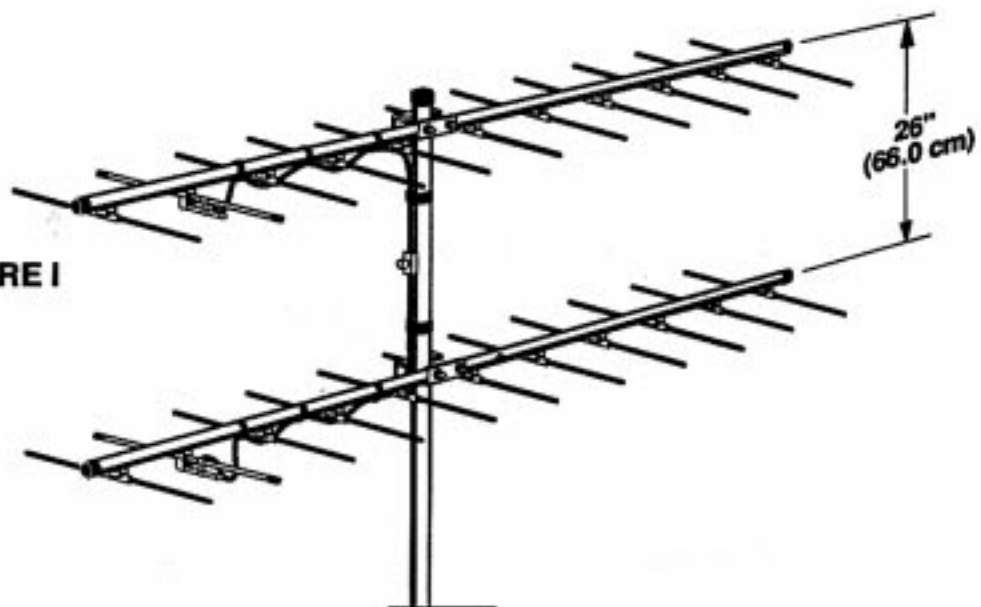

FIGURE I

### SPECIFICATIONS

<b>MODEL</b>	<b>A430-11</b>	<b>Boom Length, ft (m)</b>	<b>4.7 (1.4)</b>
<b>Frequency, MHz</b>	<b>430-435</b>	<b>Longest Element, in (cm)</b>	<b>14 (.35)</b>
<b>No. Elements</b>	<b>11</b>	<b>Turning Radius, ft (m)</b>	<b>2.6 (.81)</b>
<b>Forward Gain, dBd</b>	<b>13.2</b>	<b>Meat Size Range, in (cm)</b>	<b>1.25-1.5</b>
<b>Front to Back Ratio, dB</b>	<b>20</b>		<b>(3.1-3.8)</b>
<b>SWR 1.2:1 Typical</b>		<b>Wind Load, ft<sup>2</sup> (m<sup>2</sup>)</b>	<b>0.42 (0.04)</b>
<b>2:1 Bandwidth MHz</b>	<b>&gt;10</b>	<b>Weight, lb (kg)</b>	<b>3 (1.4)</b>
<b>Power Rating, Watts PEP</b>	<b>350</b>		
<b>3 dB Beamwidth, Degrees</b>			
<b>E Plane</b>	<b>38</b>		

#### LIMITED WARRANTY

Cushcraft Corporation, P.O. Box 4580, Manchester, New Hampshire 03108, warrants to the original consumer purchaser for one year from date of purchase that each Cushcraft antenna is free of defects in material or workmanship. If, in the judgement of Cushcraft, any such antenna is defective, then Cushcraft Corporation will, at its option, repair or replace the antenna at its expense within thirty days of the date the antenna is returned (at purchaser's expense) to Cushcraft or one of its authorized representatives. This warranty is in lieu of all other expressed warranties, any implied warranty is limited in duration to one year. Cushcraft Corporation shall not be liable for any incidental or consequential damages which may result from a defect. Some states do not allow limitations on how long an implied warranty lasts or exclusions or limitations of incidental or consequential damages, so the above limitation and exclusion may not apply to you. This warranty gives you specific legal rights, and you may also have other rights which vary from state to state. This warranty does not extend to any products which have been subject to misuse, neglect, accident or improper installation. Any repairs or alterations outside of the Cushcraft factory will nullify this warranty.



48 PERIMETER ROAD, MANCHESTER, NH 03108  
603-627-7877 / TELEX 4949472 / FAX 603-627-1764

SPECIFICATIONS SUBJECT TO CHANGE WITHOUT NOTICE

TA5FA