

ASSEMBLY AND INSTALLATION

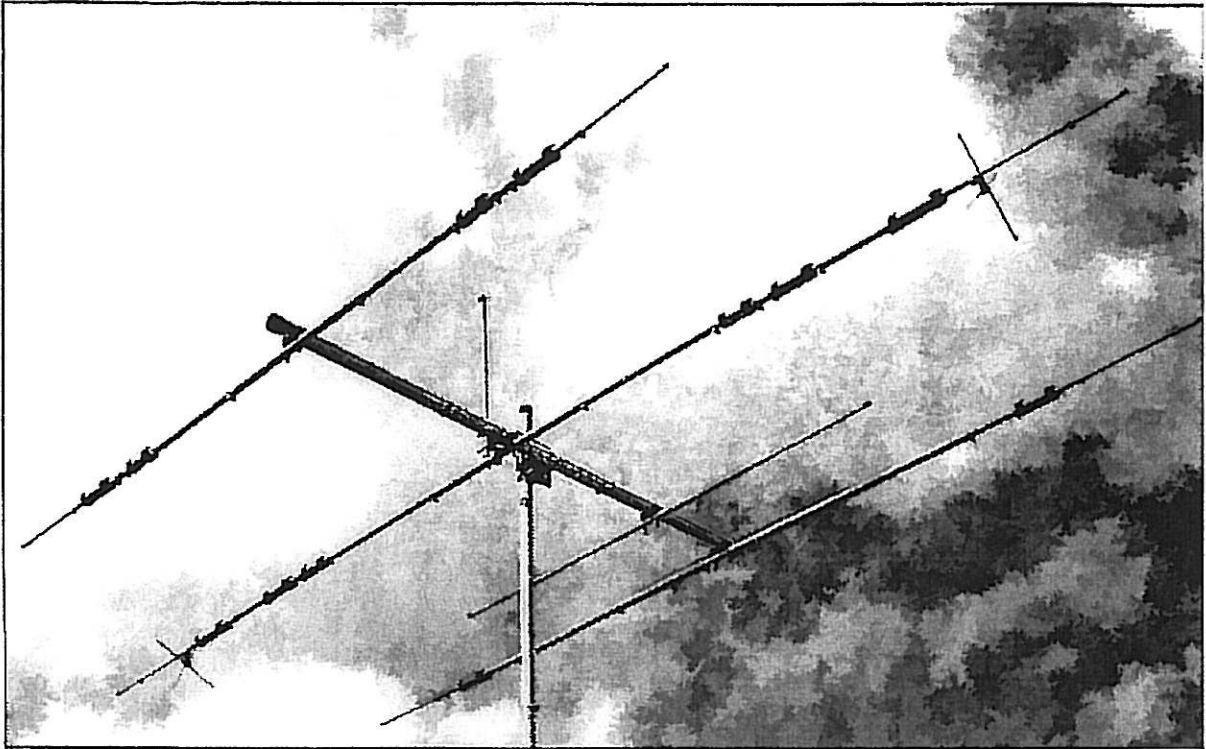

A743 & A744 Add-On

Adds 40 or 30 Meter Operation
For A3S or A4S Antennas

*A743 for A3S

*A744 for A4S



CUSHCRAFT
CORPORATION

TA5FA
951451_GF_AA

ASSEMBLY

The procedure for assembly of the A743/A744 is straight forward as depicted in the illustrations. See the main pictorial on Page 2 for an overall view of the assembled antenna.

Begin by checking the parts supplied against the combined lists. After removing your antenna from it's support, remove the driven element. Remove the center insulator and replace it with the one provided. Complete subassemblies as shown in Steps 2 through 5. Notice that Steps 4 and 5 show full assembly used for 7 MHz, and Step 6A shows alternative for 10 MHz. Remove the tubing sections from the end of your existing element. Place the new assembly C cover over the ends of the 15 meter trap (TC). Adjusts the lengths per Step 6B. Place the support mast E on the boom and feed the support guy line as shown by Step 7. Adjust the support mast until the driven element is parallel to the other elements. Replace the antenna on your tower.

KEY	PART #	DESCRIPTION	QUANTITY
98	122098	Center insulator 1"OD x 0.25 wall x 10" (A743)	1
97	122097	Center insulator 1"OD x 0.25 wall x 10" (A744)	1
	951281	Installation manual A743 and A744	
FA	A743FA	Aluminum tube 3/4"OD x .035 wall x 3"	2
FB	A743FB	Aluminum tube 7/8"OD x .058 wall x 13 1/4"	2
FC	A743FC	Aluminum tube 1"OD x .058 wall x 7"	2
FD	A743FD	Aluminum tube 3/8"OD x .058 wall x 42" (40M SETUP ONLY)	2
FG	A743FG	Aluminum tube 1/2"OD x .049 x 24"	2
FH	A743FH	Aluminum tube 1 1/8" x .058 x 24" (GUYLINE SUPPORT BOTTOM)	1
FJ	A743FJ	Aluminum tube 1" x .058 x 24" (GUYLINE SUPPORT TOP)	1
XHR	A743XHR	Aluminum rod 3/16" x 28 3/4" (40M SETUP ONLY)	4
FN	GUYLINE	3mm x 23' danscord	1
TK	TK	20M trap	2
40	10040	Machine screw #8 - 32 x 1 1/4"	2
72	10072	Machine screw #8 - 32 x 3/4"	2
232	10232	Machine screw #8 - 32 x 2 1/2"	4
405	10405	U-bolt - 5/16" x 2 1/8" ID x 4 - 1/2"	1
409	30409	Worm clamp 3/8" - 7/8" (40M SETUP ONLY)	2
410	30410	Worm clamp 7/16" - 1"	2
411	30411	Worm clamp 9/16" - 1 1/4"	7
38	50038	Cap plastic black 1"	1
53	50053	Cap plastic black 1/2" (30M SETUP ONLY)	2
77	50077	Cap plastic black 3/8" (40M SETUP ONLY)	2
26	190026	Aluminum pillow bracket	3
32	190032	Aluminum bracket for 405 U-bolt	1
33	190033	Aluminum backing plate for 405 U-bolt	1
157	190157	Aluminum bracket for mounting x hats (40M SETUP ONLY)	2
88	200088	Aluminum clamp guyline to driven element	2
56	320056	Aluminum spacer (used with 88)	2
FM	324071	Phenolic tube (drilled) guyline mounting	1
11	10011	Nut hex 18 - 8ss #8 - 32	6 (3-5 extra)
941	11941	Washer lock split 18 - 8ss, 1 #8	10 (3-9 extra)
118	10118	Nut hex 18 - 8ss 5/16" - 18	5 (1extra)
119	10119	Washer lock split 18 - 8ss, 5/16	5 (1 extra)

TA5FA

The A743 and A744 extend the driven element on A3S or A4S to resonate on 30m or 40m (chosen at set up time) while maintaining operation on 10/15/20m. all using one feed line

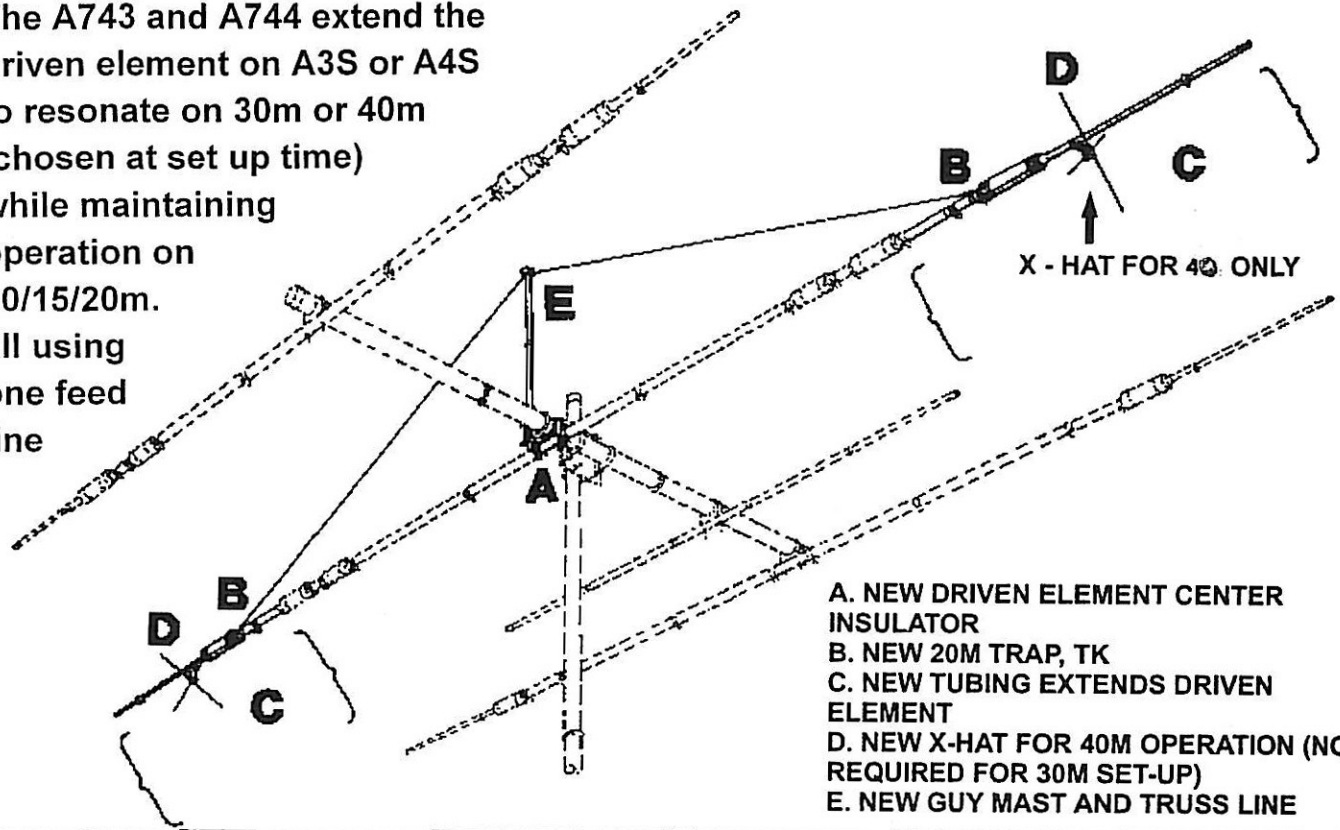

- A. NEW DRIVEN ELEMENT CENTER INSULATOR
- B. NEW 20M TRAP, TK
- C. NEW TUBING EXTENDS DRIVEN ELEMENT
- D. NEW X-HAT FOR 40M OPERATION (NOT REQUIRED FOR 30M SET-UP)
- E. NEW GUY MAST AND TRUSS LINE

1 PARTS REPLACED

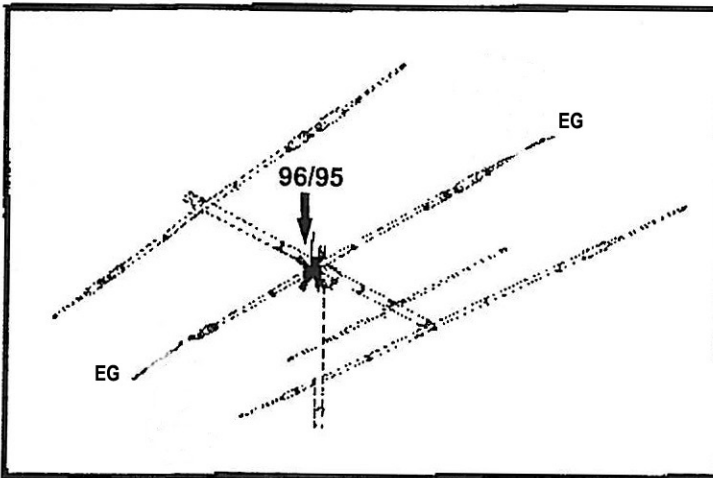

P/N		DETAIL	DESC.	SIZE	QTY
A3	A4				
96	95		FIBERGLASS INSULATOR	1"OD x 10" (2.5cm x 25.4cm)	1
EG	EG		ALUMINUM TUBING	1/2" OD x 35% (1.3cm x 91cm) x .035" wall	2

*** FIBERGLASS INSULATOR 95/96 IS REPLACED BY 96/97 (THICKER WALL)

*** EG TUBING IS REPLACED BY FG (AND FD FOR 40M SET-UP).

2 NEW INSULATOR ASSEMBLY

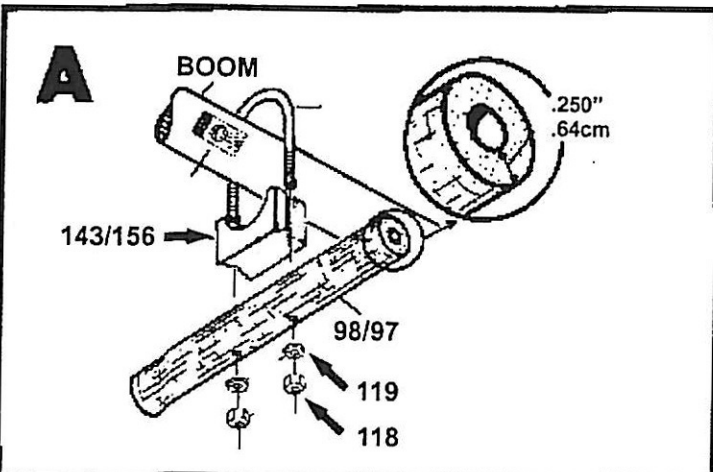

98	97		FIBERGLASS INSULATOR	1"OD x .25" x 10" (2.5cm x 25.4cm)	2
500	500		WARNING LABEL		2

*** RETAIN ALUMINUM PILLOW BRACKET 143 (A3S) OR 156 (A4S) AND U-BOLT FROM ORIGINAL INSULATOR MOUNTING. ADD NEW 5/16 NUTS AND WASHERS.

TA5FA

3 GUYLINE CLAMP ASSEMBLY

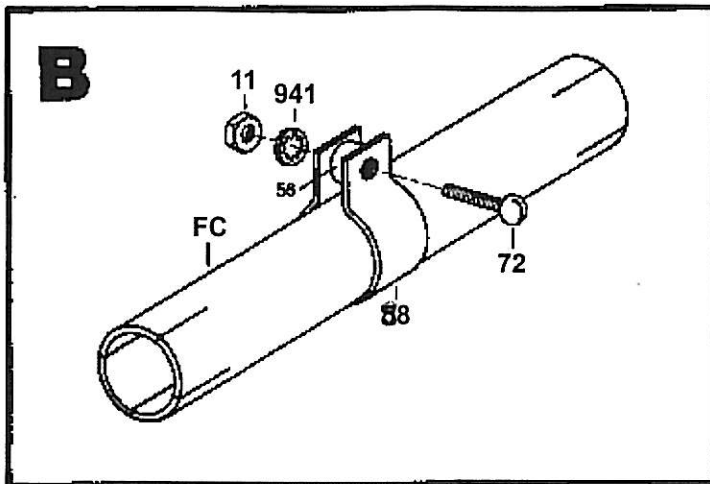

P/N	DETAIL	DESC.	SIZE	QTY
88		GUY LINE CLAMP	1"(2.5cm)	2
56		ALUMINUM SPACER	7/16" x 1/4" (.79 x .64cm)	2
72		SS MACHINE SCREW	#8-32 x 3/4" (1.9cm)	2
941		SS SPLIT LOCKWASHER	#8-32	2
11		SS HEX NUT	#8-32	2
FC		ALUMINUM TUBING	1" x .058" x 7" (2.5 x 17.8cm)	2

4 40 METER (7MHz) ASSEMBLY

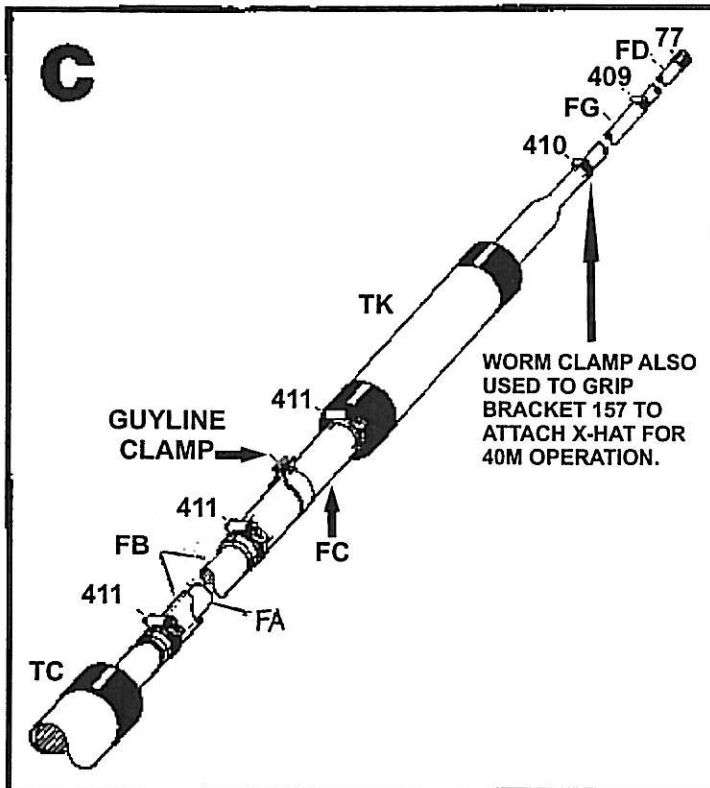

410		SS WORM CLAMP	1 1/4" (3.5cm)	2
FA		ALUMINUM TUBING	3/8" x .035" x 3" (1.9 x 7.5cm)	2
FB		ALUMINUM TUBING	3/8" x .058" x 13 1/2" (2.2 x 33.8cm)	2
TK		TK 20 METER TRAP		2
409		SS WORM CLAMP	3/4" (2.2cm)	2
411		SS WORM CLAMP	5/8" (1.3cm)	6
FG		ALUMINUM TUBING	1/2" x .049" x 24" (1.3 x 61.0cm)	2
FD*		ALUMINUM TUBING	3/8" x .058" x 42" (.8 x 106.7cm)	2
77*		BLACK PLASTIC GAP	3/8" (.95cm)	2

* FD AND 77 USED FOR 40M SET-UP ONLY

5 40 METER (7 Mhz) X-HAT ASSEMBLY (X-HAT NOT USED FOR 30M)

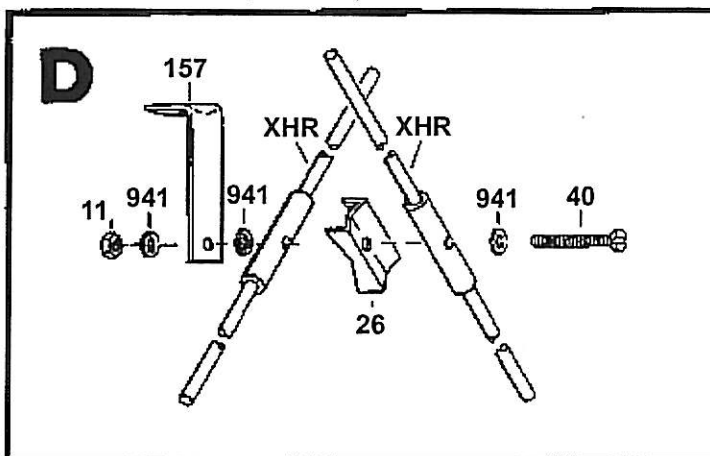

XHR		ALUMINUM ROD	3/8" x 28 3/4" (0.48 x 73.03cm)	4
26		FORMED ALUMINUM BLOCK	3/4" (2.2cm)	2
157		FORMED ALUMINUM BRACKET	2" x 3/4" (5.1 x 1.9cm)	2
40		SS MACHINE SCREW 010040	#8-32 x 1 1/2" (3.18cm)	2
941		SS SPLIT LOCKWASHER	#8-32	6
11		SS HEX NUT	#8-32	2

TA5FA

6A ELEMENT END ASSEMBLY

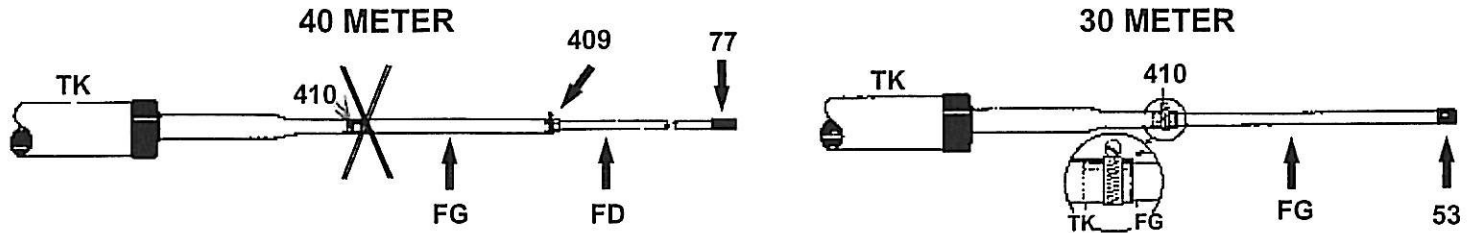

***X - HAT AND TUBE FD ONLY USED FOR 40M SET UP.
WORM 410 HOLDS BRACKET 157 TO SUPPORT X-HAT.

***30M OPERATION USES ONLY TUBE FG. THE X-HAT
SUPPLIED IS NOT USED.

6B DRIVEN ELEMENT LENGTH ADJUSTMENT

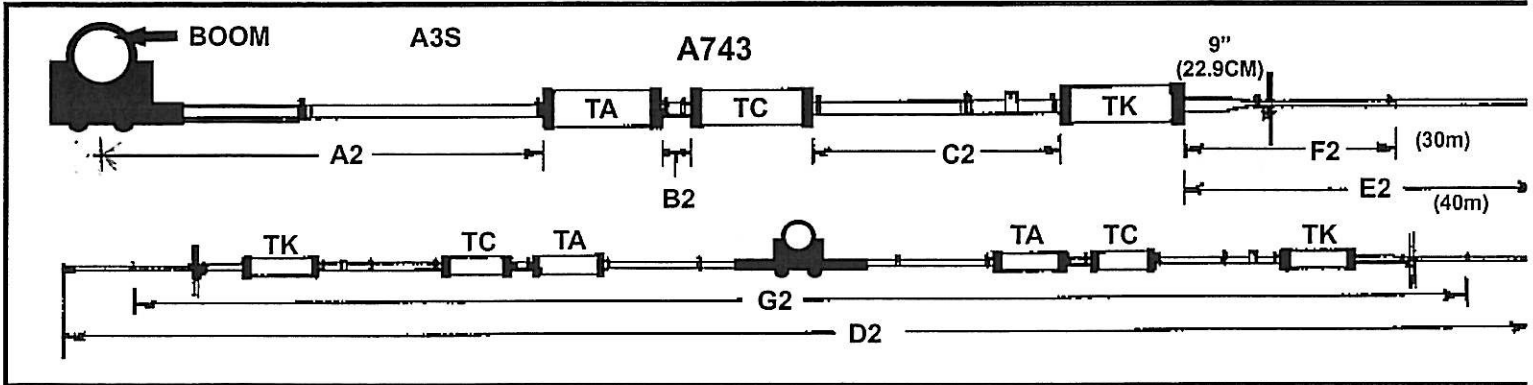

A743 DRIVEN ELEMENT LENGTH ADJUSTMENT

	40 METER (7MHz0)					30 METER (10MHz)				
	A2	B2	C2	E2	D2	A2	B2	C2	F2	G2
CODE:	FT-IN CM	IN CM	IN CM	FT-IN CM	FT-IN METERS	FT-IN CM	IN CM	IN CM	IN CM	FT-IN METERS
PHONE	6 - 8 1/4" 203.8	5.75" 14.6	18 3/4" 47.6	5' - 3/8" 153.3	33' - 2 1/4" 10.11	6' - 9 1/4" 206.4	5 3/4" 14.6	19 1/4" 48.9	24 5/8" 62.6	27' - 5 3/4" 8.38
CENTER	6 - 11 1/2" 212.1	6 15.2	19 48.3	5' - 3 1/8" 160.3	34' - 3 1/4" 10.44	6' - 11 1/2" 212.1	6 15.2	19 1/2" 49.5	24 1/2" 62.23	27' - 11 8.5
CW	7 - 7/8" 215.6	7 17.8	20 50.8	5' - 6 1/8" 168	35' - 4 10.77	7' - 7/8" 215.6	7" 17.8	20 1/4" 51.4	24 1/4" 61.6	28' 4 3/4" 8.66

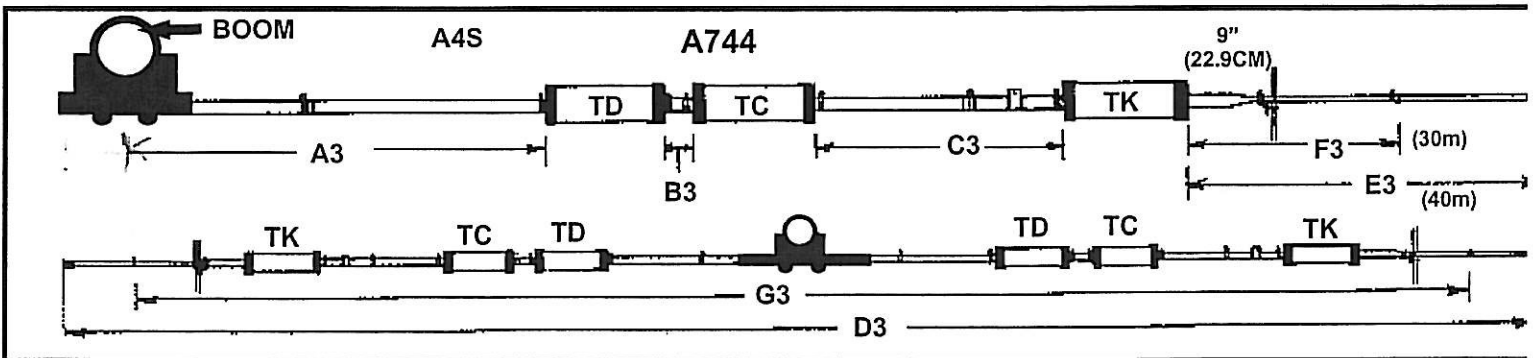

A744 DRIVEN ELEMENT LENGTH ADJUSTMENT

	40 METER (7MHz0)					30 METER (10MHz)				
	A3	B3	C3	E3	D3	A3	B3	C3	F3	G3
CODE:	FT-IN CM	IN CM	IN CM	FT-IN CM	FT-IN METERS	FT-IN CM	IN CM	IN CM	IN CM	FT-IN METERS
PHONE	6 - 6 198.1	5 3/4" 14.6	20 1/4" 51.4	5 - 2 1/2" 158.7	33 - 5 10.19	6 - 6 198.1	5 3/4" 14.6	20 1/4" 51.4	24 3/4" 62.9	27 - 1 1/2" 8.27
CENTER	6 - 7 200.7	5 3/4" 14.6	20 1/4" 51.4	5 - 3 1/2" 161.3	33 - 9 10.9	6 - 7 200.7	5 3/4" 14.6	20 1/4" 51.4	24 5/8" 62.5	27 - 3 1/4" 8.31
CW	6' - 11 1/2" 212.1	6 3/4" 17.1	20 3/4" 52.7	5 - 6 1/2" 169	35 - 3 10.74	6 - 11 1/2" 212.1	6 3/4" 17.1	20 3/4" 52.7	24 7/8" 61.9	28 - 2 3/4" 8.6

7 DRIVEN ELEMENT SUPPORT MAST ASSEMBLY

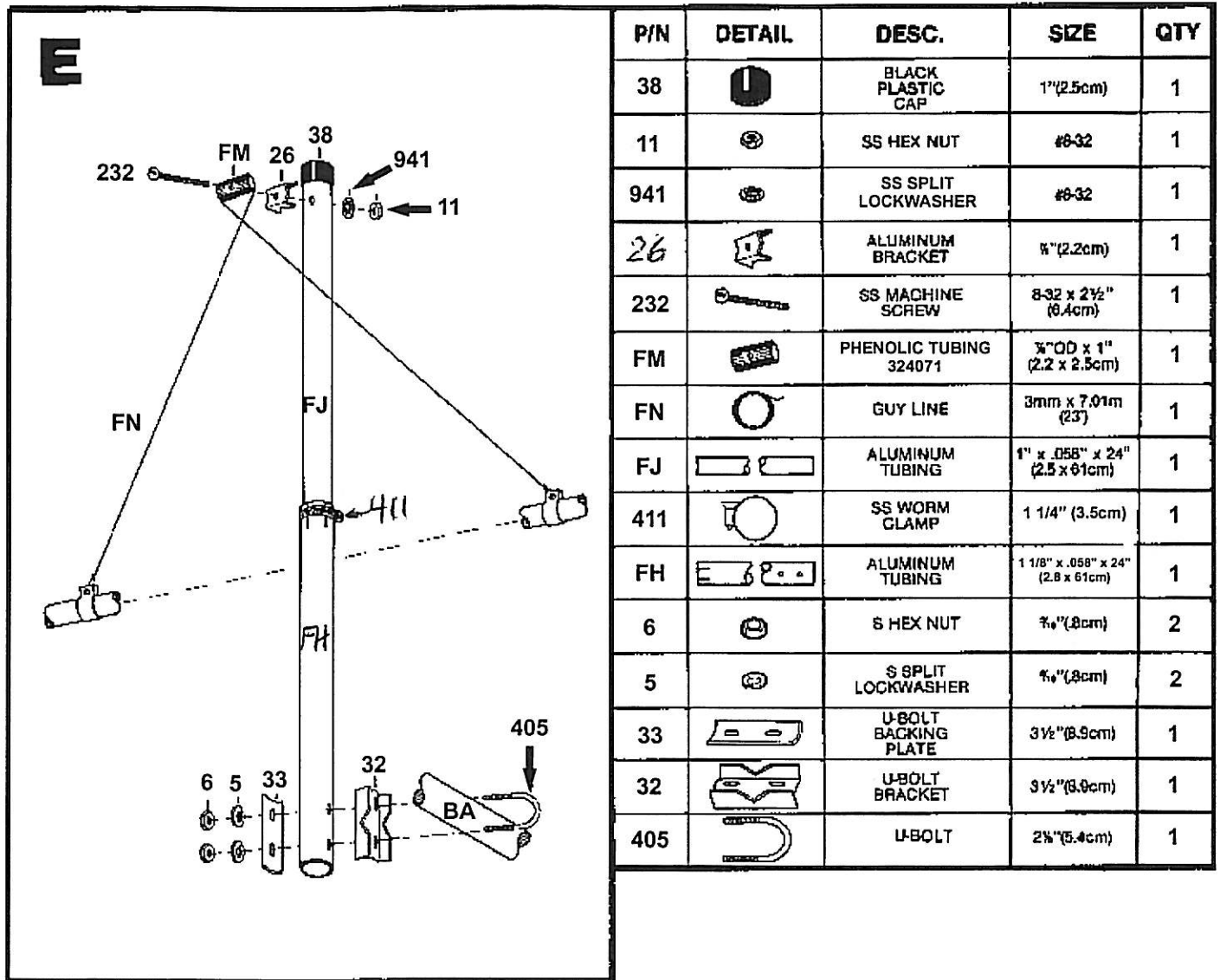

8 ADJUST GUYLINE

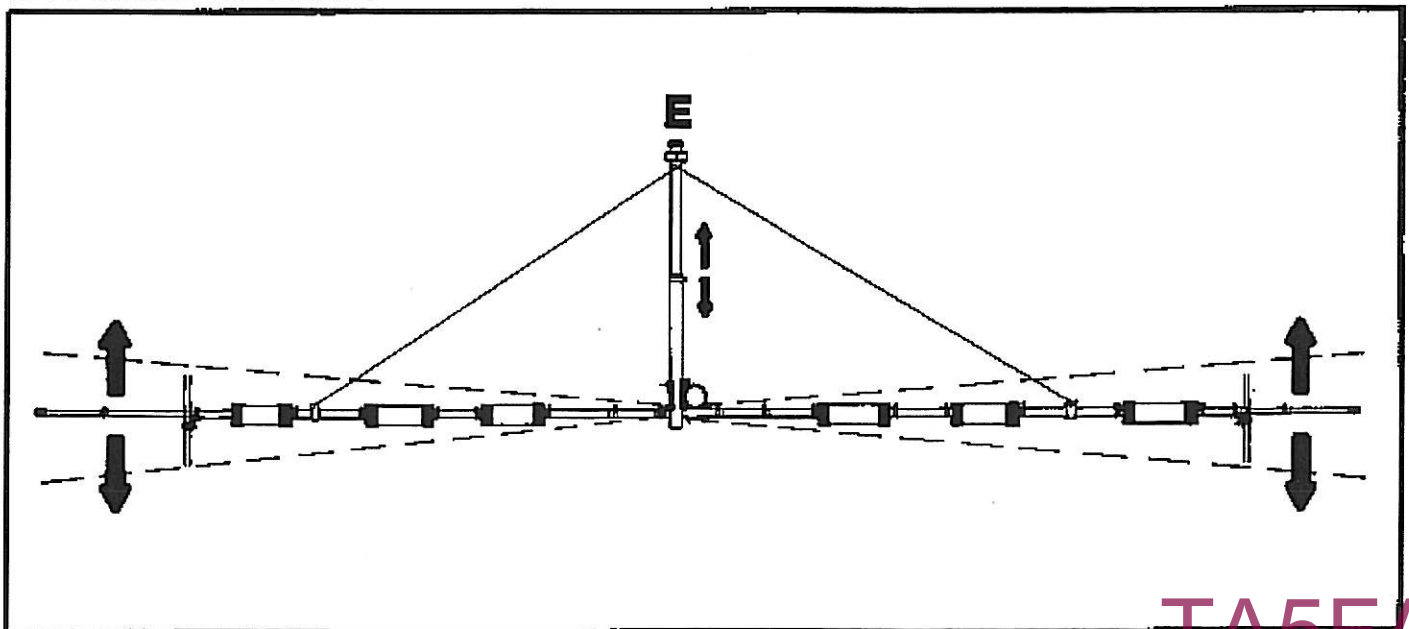

TA5FA

A743 and A744 Common Specifications

Parameter	Set up Frequency of Operation	
	40 Meters	30 Meters
Gain	2 dBi (0 dBd)	2 dBi (0 dBd)
Frequency Range (tunable)	7.0 MHz - 7.3 MHz	10.1 - 10.15 MHz
2:1 SWR Bandwidth	125 kHz	150 kHz
Driven Element Length	35' - 4" (10.7m) max.	28' - 4" (8.6 m) max.
A3S Turning Radius w/ Add-on	17' - 8" (5.38m)	15' - 7" (4.74m)
A4S Turning Radius (not affected)	18' - 1" (5.51m)	18' - 1" (5.51m)
Power Handling	1500 W (PEP)	1500W (PEP)
A3S Wind Loading w/ Add-on	4.94 sq. ft. (0.46 sq. m)	4.68 sq. ft. (0.43 sq. m)
A4S Wind Loading w/ Add-on	6.08 sq. ft (0.56 sq. m)	5.82 sq. ft.(0.54 sq. m)
Weight Added	3.4 lbs. (1.56 kg)	3.25 lbs. (1.47 kg)
A3S Total Weight	30.4 lbs. (13.8 kg)	30.25 lbs. (17.3 kg)
A4S Total Weight	40.4 lbs. (18.34 kg)	40.25 lbs. (18.27 kg)
Input Connector	Unchanged by addition	Unchanged by addition
Shipping Dimensions (inches)	4-1/8" x 2-1/8" x 57-1/2"	4-1/8" x 2-1/8" x 57-1/2"
Shipping Dimensions (cm)	10.5 x 4.0 x 146	10.5 x 4.0 x 146
Shipping Weight	7.5 lbs. (3.4 kg)	7.5 lbs. (3.4 kg)

If you have technical questions and have access to the World Wide Web you can visit Cushcraft's **TECHEXPRESS** support service (<http://www.cushcraft.com>). The site enables the user to place parts orders, ask technical questions, locate part numbers, initiate warranty inquires and review *Frequently Asked Questions*. Our technical support staff can be reached by phone at (603) 627-7877 (8 AM to 5 PM Eastern time or voice mail after hours), faxed at (603) 627-1764 or can be e-mailed at techsup@cushcraft.com.

Limited Warranty

Cushcraft Corporation, 48 Perimeter Road, Manchester, New Hampshire 03103, warrants to the original consumer purchaser for one year from date of purchase that each Cushcraft antenna is free of defects in material or workmanship. If, in the judgement of Cushcraft, any such antenna is defective, then Cushcraft will, at its option, repair or replace the antenna at its expense within thirty days of the date the antenna is returned (at purchaser's expense) to Cushcraft or one of its authorized representatives. This warranty is in lieu of all other expressed warranties. Any implied warranty is limited in duration to one year. Cushcraft Corporation shall not be liable for any incidental or consequential damages which may result from a defect. Some states do not allow a limitation on how long an implied warranty lasts or exclusions or limitations of incidental or consequential damages, so the above limitation and exclusion may not apply to you. This warranty gives you specific legal rights, and you may also have other rights which vary from state to state. This warranty does not extend to any products which have been subject to misuse, neglect, accident or improper installation. Any repairs or alterations outside of the Cushcraft factory will nullify this warranty.



CUSHCRAFT
COMMUNICATIONS ANTENNAS

48 Perimeter Road, Manchester NH 03103 USA • Telephone: 603-627-7877 • Fax: 603-627-1764 • E-mail: techsup@cushcraft.com
Web Site: <http://www.cushcraft.com> • International - Tel: +1-603-627-7877 • Fax: +1-603-627-1764

SPECIFICATIONS SUBJECT TO CHANGE WITHOUT NOTICE

TA5FA