

# THE **DIRECTOR**

HF multiband beam antenna

ASSEMBLY AND INSTALLATION  
INSTRUCTIONS



# MA5B

20 / 17 / 15 / 12 / 10 Meter Beam Antenna



**CUSHCRAFT**  
COMMUNICATIONS ANTENNAS

951485 (5/99) **TA5FA**

**WARNING**

THIS ANTENNA IS AN ELECTRICAL CONDUCTOR. CONTACT WITH POWER LINES CAN RESULT IN DEATH, OR SERIOUS INJURY. DO NOT INSTALL THIS ANTENNA WHERE THERE IS ANY POSSIBILITY OF CONTACT WITH OR HIGH VOLTAGE ARC-OVER FROM POWER CABLES OR SERVICE DROPS TO BUILDINGS. THE ANTENNA, SUPPORTING MAST AND/OR TOWER MUST NOT BE CLOSE TO ANY POWER LINES DURING INSTALLATION, REMOVAL OR IN THE EVENT PART OF THE SYSTEM SHOULD ACCIDENTALLY FALL. FOLLOW THE GUIDELINES FOR ANTENNA INSTALLATIONS RECOMMENDED BY THE U.S. CONSUMER PRODUCT SAFETY COMMISSION AND LISTED IN THE ENCLOSED PAMPHLET.

Your Cushcraft MA5B Yagi is designed and manufactured to give trouble free service. This antenna will perform as specified if the instructions and suggestions in this manual are followed and care is used in the assembly and installation. When checking the components received in your antenna package use the parts listed beside each diagram. There is a master parts list on page 2. If you are unable to locate any tube or component, check the inside of all tubing. **IMPORTANT:** Save the weight label from the outside of the carton. Each antenna is weighed at the factory to verify the parts count. If you claim a missing part, you will be asked for the weight verification label.

**PLANNING**

Plan your installation carefully. If you use volunteer helpers be sure that they are qualified to assist you. Make certain that everyone involved understands that you are the boss and that they must follow your instructions. If you have any doubts at all, employ a professional antenna installation company to install your antenna.

**LOCATION**

Location of the antenna is very important. Surrounding objects such as trees, power lines, other antennas, etc. will seriously reduce efficiency. To minimize the effects of surrounding objects, mount the antenna as high and in the clear as possible. If metal guy wires are used, they should be broken with strain insulators. **EXTREME CARE MUST BE USED FOR YOUR SAFETY. YOU MUST INSURE THAT WHILE THE MA5B IS IN OPERATION NEITHER PEOPLE OR PETS CAN COME IN CONTACT WITH ANY PORTION OF YOUR ANTENNA. DEADLY VOLTAGES AND CURRENTS MAY EXIST. ALSO, SINCE THE EFFECTS OF EXPOSURE TO RF FIELDS ARE NOT FULLY UNDERSTOOD, LONG TERM EXPOSURE TO INTENSE RF FIELDS IS NOT RECOMMENDED. THERE IS A WARNING STICKER WHICH MUST BE ATTACHED TO THE BOOM AS SHOWN IN FIGURE I.**

**MOUNTING**

The mast mount bracket will accommodate up to a 2" (5.1 cm) mast. A 1-1/2" OD (3.8 cm) or larger heavy wall tubing mast should be used. A good heavy duty antenna rotator will provide the best service and longest life. Often it is desirable to mount several antennas on one mast. To keep possible interaction to a minimum, place your antennas as far apart as you can.

**SYSTEM GROUNDING**

Direct grounding of the antenna, mast and tower is very important. This serves as protection from lightning strikes and static buildup, and from high voltage which is present in the radio equipment connected to the antenna. A good electrical connection should be made to one or more ground rods (or other extensive ground system) directly at the base of the tower or mast, using at least #10AWG ground wire and noncorrosive hardware. For details and safety standards, consult the National Electrical Code. You should also use a coaxial lightning arrester. Cushcraft offers several different models, such as LAC-1, LAC-2 and the LAC-4 series.

**ASSEMBLY**

Assemble your antenna by following the directions and illustrations in steps 1 through 6. After the antenna is completely assembled, verify dimensions and element spacings for accuracy. Then, return to the section below for final tuning.

**TUNING PROCEDURE**

Set the element lengths for the portion of the band you want to operate on using Chart A and Figure 2. Your MA5B is now ready for use.

You may check the VSWR in order to confirm assembly was done properly. The easiest place to check the antenna is likely to be in its final mounting configuration. Orient the antenna such that it is pointing straight up. The back of the antenna should be at least 2 feet (.6 m) off the ground.

Run the coax cable from your transmitter to the area in which the antenna is to be tested. The length of this cable or your feedline is not critical. Connect a good quality VSWR bridge to the end of this cable. Connect a short length of cable [10 ft. (305 cm) or less] from the VSWR bridge to the antenna under test. Set the transmitter to your center operating frequency and measure the VSWR while taking care not to effect the measurement with your body. A VSWR of 2:1 or less is satisfactory and will not degrade the performance. If the VSWR is greater than 2:1, check all dimensions and connectors.

## MASTER PARTS LIST

KEY	PART#	DESCRIPTION	QTY
MT3	MT3	21/28 MHz TRAP ASSEMBLY	2
MT2	MT2	24.9 MHz TRAP ASSEMBLY	2
MT1	MT1	21/28 MHz TRAP ASSEMBLY	2
MN	MN5B	MA5B MATCHING NETWORK	1
EF	MA5BEF	MA5B ELEMENT EF (1-1/8" x 84")	1
EE	MA5BEE	MA5B ELEMENT EE (7/8" x 12")	2
ED	MA5BED	MA5B ELEMENT ED (1-1/8" x 46")	2
EC	MA5BEC	MA5B ELEMENT EC (7/8" x 7")	4
EB	MA5BEB	MA5B ELEMENT EB (1-7/8" x 36" SW)	6
EA	MA5BEA	MA5B ELEMENT EA (1-1/8" x 34")	2
BB	MA5BBB	MA5B BOOM BB (1-5/8" x 24")	1
BA	MA5BBA	MA5B BOOM BA (1-1/2" x 44")	2
116	240116	SILICONE PACKAGE	1
115	050115	CONNECTOR BOOT	1
326	290326	DANGER LABEL	1
342	030342	BLACK TIE WRAP	4
404	010404	5/16-18 x 2-7/16 SS U-BOLT	2
403	010403	5/16-18 x 1.955 SS U-BOLT	2
70	190070	BOOM TO MAST PLATE	1
19	010119	5/16 SS SPLIT LOCK WASHER	8
18	010118	5/16-18 SS HEX NUT	8
X41	XHR41	41" X-HAT ROD	12
X26	XHR26	26" X-HAT ROD	8
28	190028	HALF WASHER	20
26	190026	ELEMENT BRACKET	20
85	010085	1/4-20 SS HEX NUT	6
84	010084	1/4" SS SPLIT LOCK WASHER	6
33	190033	U-BOLT BACKING PLATE	3
143	190143	ELEMENT TO BOOM CLAMP	3
402	010402	1/4-20 x 1-3/4" SS U-BOLT	3
11	010011	#8-32 SS HEX NUT	28
41	011941	#8 SS SPLIT LOCK WASHER	28
31	010231	#8-32 x 1 3/4" SS RH MACHINE SCREW	24
96	122096	FIBERGLASS INSULATOR	2
61	050061	7/8" BLACK PLASTIC CAP	6
410	030410	WORM CLAMP 7/16"-1"	12
411	030411	WORM CLAMP 9/16"—1-1/4"	6
46	050046	1-1/2" BLACK PLASTIC CAP	2
413	030413	WORM CLAMP SS 3/4"—1 3/4"	4

# 1 - BOOM ASSEMBLY

Place the worm clamps (413) over the slotted ends of tube BB. Slide both BA sections into BB as shown in Figure 1. Each BA section should be inserted 12 inches (30.5 cm) into section BB to leave 32 inches (81.3 cm) exposed on each end. Tighten the worm clamps. Place the plastic caps (46) on the ends of the boom assembly.

Locate the boom to mast plate (70) at a distance of 36 inches (91.4 cm) from one end as shown in Figure 1. Bolt the plate to the boom using the U-bolts (403), lock washers (19), and hex nuts (18). Apply the danger label (326) to the boom near the mast plate.







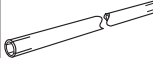


KEY	P/N	DISPLAY	DESC	SIZE	QTY
18	010118		SS Hex Nut	5/16-18	4
19	010119		SS Lock Washer	5/16	4
46	050046		Plastic Cap	1-1/2" (3.8 cm)	2
70	190070		Boom To Mast Plate	6" x 3-1/2" (15.2 x 8.9 cm)	1
403	010403		U-Bolt	5/16" x 2" (5.1 cm)	2
413	030413		Worm Clamp	1-3/4" (4.4 cm)	2
BA	MA5BBA		Aluminum Tube	1-1/2" x 44" (3.8 x 111.7 cm)	2
BB	MA5BBB		Aluminum Tube	1-5/8" x 24" (4.1 x 61 cm)	1
326	290326		Warning Label		1

FIGURE 1

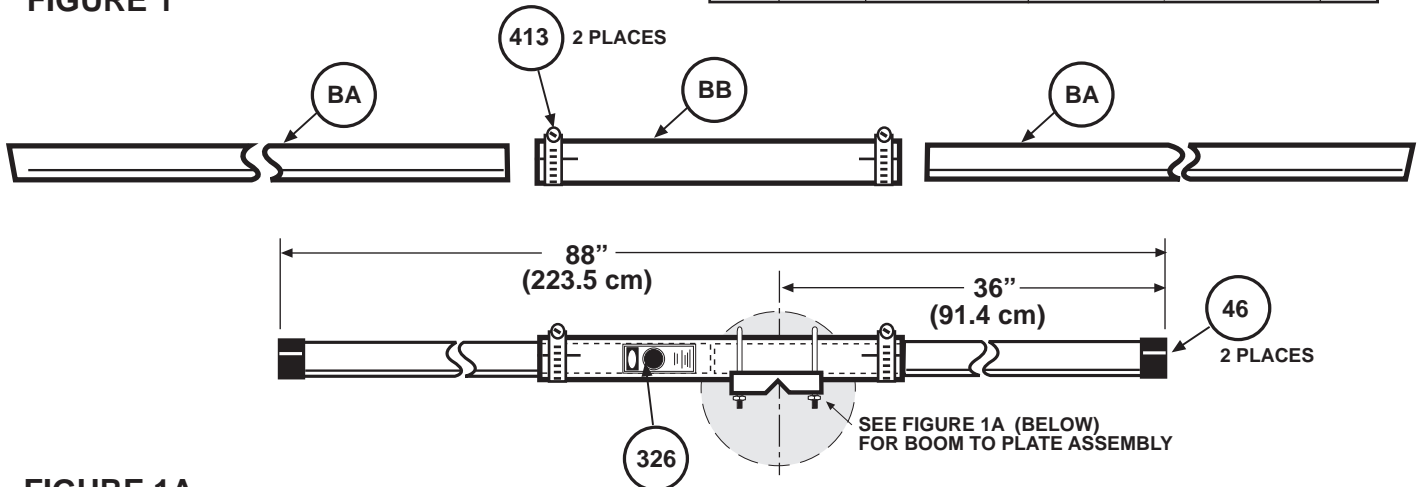
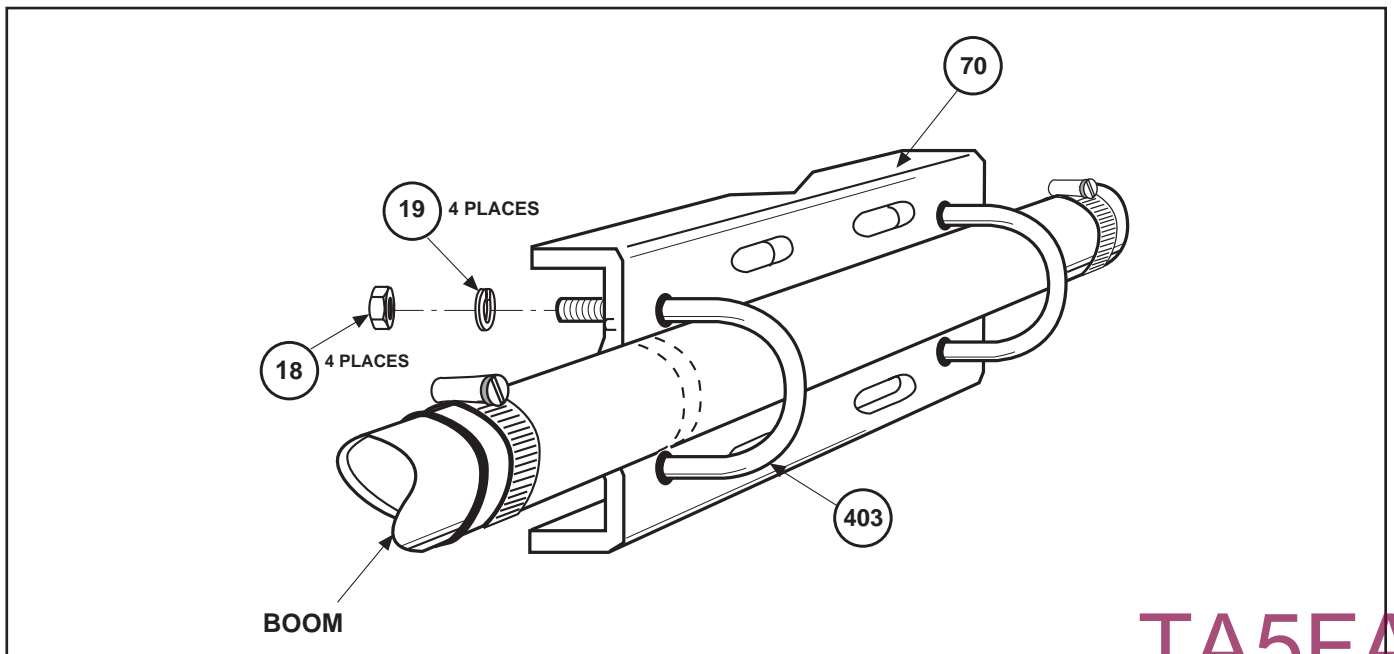


FIGURE 1A


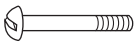


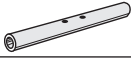


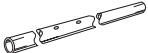










## 2 Element Assembly

Assemble the elements per Figure 2. To assemble element #1, insert the Fiberglass insulator (98) into element sections EA and align the outer holes of the insulator with the holes in section EA. Place the 8-32 machine screws (31) through the two holes and fasten with lock washers (41) and hex nuts (11) as shown in Figure 2B. Place worm clamps (411) over the ends of element EA and worm clamps (410) over the ends of elements EB and EC. Insert elements EB into elements EA to a 4-inch insert length. Tighten the worm clamps. Insert the MT1 traps into elements EB and EC, with the arrows pointing toward elements EC. Adjust the total length of the assembly by using Chart A. Place the plastic endcaps (61) over the ends of elements EC.

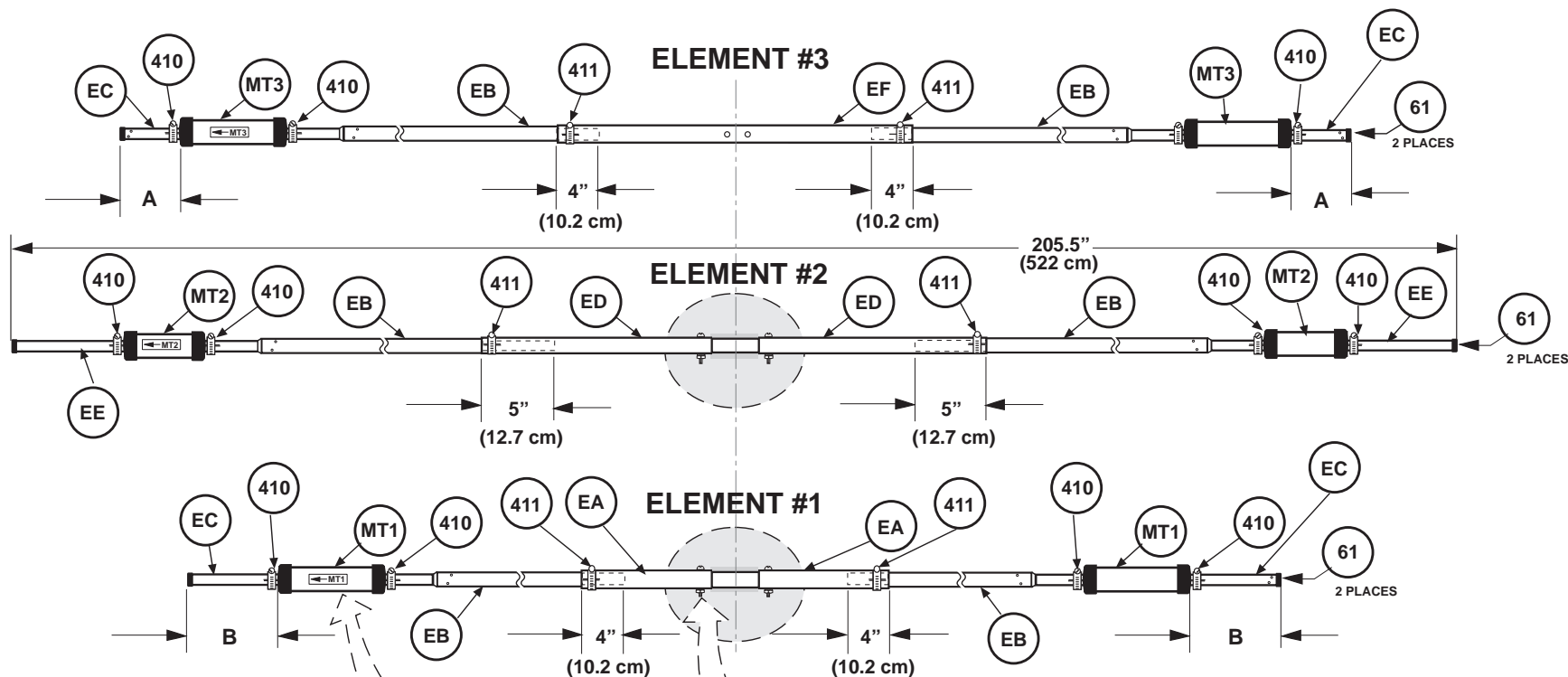
To assemble element #2, insert the Fiberglass insulator (98) into element sections ED and align the outer holes of the insulator with the holes in section ED. Place the 8-32 machine screws (31) through the two holes and fasten with lock washers (41) and hex nuts (11). Place worm clamps (411) over the ends of element ED. Place worm clamps (410) over the ends of elements EB and EE. Insert elements EB into elements ED to a 5-inch insert length. Tighten the worm clamps. Insert the MT2 traps into elements EB and EE, with the arrows pointing toward elements EE. Adjust the total length of the assembly to 205.5 inches (522 cm). Place the plastic endcaps (61) over the ends of elements EE.

To assemble element #3, place worm clamps (411) over the ends of element EF. Place worm clamps (410) over the slotted ends of elements EB and EC. Insert elements EB into elements EF to a 4-inch insert length. Tighten the worm clamps. Insert the MT3 traps, with arrows pointing toward elements EC, into the ends of elements EB. Tighten the worm clamps. Place elements EC over the ends of the traps and tighten the worm clamps. Adjust the total length of element #3 by using Chart A. Place the plastic endcaps (61) over the ends of elements EC.

KEY	P/N	DISPLAY	DESC	SIZE	QTY
11	010011		SS HEX NUT	8-32	4
31	010231		SS SCREW	8-32 x 1-3/4" (2.9 x 91.4cm)	4
41	011941		SS LOCK WASHER	8-32	4
61	050061		PLASTIC CAP	7/8" (2.2cm)	6
96	122096		FIBERGLASS INSULATOR	1" x 10" (2.5 x 25.4 cm)	2
410	030410		WORM CLAMP	1" (2.5 cm)	12
411	030411		WORM CLAMP	1- 1/4" (3.2 cm)	6
EA	MA5BEA		ALUMINUM TUBING	1-1/8" x 34" (4.4cm)	2
EB	MA5BEB		ALUMINUM TUBING	1-7/8" x 36" (4.8 x 91.4 cm)	6
EC	MA5BEC		ALUMINUM TUBING	7/8" x 7" (2.2 x 17.8 cm)	4
ED	MA5BED		ALUMINUM TUBING	1-1/8" x 46" (2.9 x 116.8 cm)	2
EE	MA5BEE		ALUMINUM TUBING	7/8" x 12" (2.2 x 30.5 cm)	2
EF	MA5BEF		ALUMINUM TUBING	1-1/8" x 84" (2.9 x 213.4 cm)	1
MT3	MT3		TRAP	24" (70 cm)	2
MT2	MT2		TRAP	17" (43.2 cm)	2
MT1	MT1		TRAP	24" (70 cm)	2

# ELEMENT ASSEMBLY Cont.

FIGURE 2



Page 5

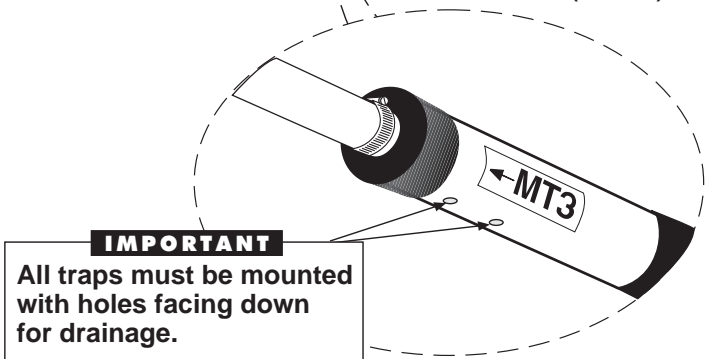


FIGURE 2A

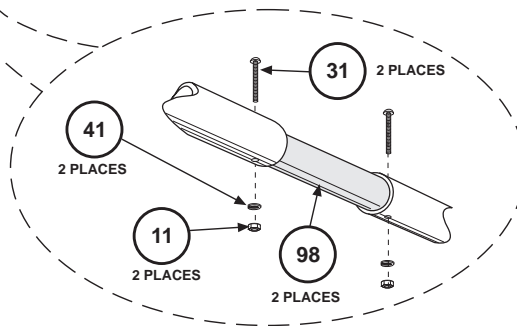


FIGURE 2B

FREQUENCY	DIM. "A"	DIM. "B"
14.025 MHz	9" (22.9 cm)	9" (22.9 cm)
14.175 MHz	8" (20.3 cm)	8" (20.3 cm)
14.300 MHz	7" (17.8 cm)	7" (17.8 cm)

TUNING CHART A

# 3-X-HAT ASSEMBLY

Raise each element assembly off the ground to attach the X-hats to the elements. For element #1, place the 41-inch X-hat rods (X41) and element brackets (26) on elements EB as shown in Figure 3B. Fasten the rods and brackets in place using 8-32 machine screws (31), half washers (28), lock washers (41), and hex nuts (11). Place the 26-inch X-hat rods (X26) and element brackets (26) on elements EC as shown in Figure 3A. Fasten the rods and brackets in place using 8-32 machine screws (31), half washers (28), lock washers (41), and hex nuts (11).

For element #2, place the 41-inch X-hat rods (X41) and element brackets (26) on elements EB as shown in Figure 3B. Fasten the rods and brackets in place using 8-32 machine screws (31), half washers (28), lock washers (41), and hex nuts (11).

For element #3, place the 41-inch X-hat rods (X41) and element brackets (26) on elements EB as shown in Figure 3B. Fasten the rods and brackets in place using 8-32 machine screws (31), half washers (28), lock washers (41), and hex nuts (11). Place the 26-inch X-hat rods (X26) and element brackets (26) on elements EC as shown in Figure 3A. Fasten the rods and brackets in place using 8-32 machine screws (31), half washers (28), lock washers (41), and hex nuts (11).

KEY	P/N	DISPLAY	DESC	SIZE	QTY
11	010011		SS HEX NUT	8-32	20
26	190026		ELEMENT BRACKET	7/8" x 7/8" (2.2 x 2.2 cm)	20
28	190028		HALF WASHER	1-1/8" x 3/8" (2.9 x 1 cm)	20
31	010231		SS SCREW	8-32 x 1-3/4" (3.81 cm)	20
41	011941		SS LOCK WASHER	8-32	20
X26	XHR26		ALUMINUM ROD	3/16" x 26" (0.5 x 66 cm)	8
X41	XHR41		ALUMINUM ROD	3/16" x 41" (0.5 x 104.1 cm)	12

SEE FIGURE 3A

## ELEMENT #3

SEE FIGURE 3B

## ELEMENT #2

SEE FIGURE 3B

SEE FIGURE 3A

## ELEMENT #1

SEE FIGURE 3B

FIGURE 3A

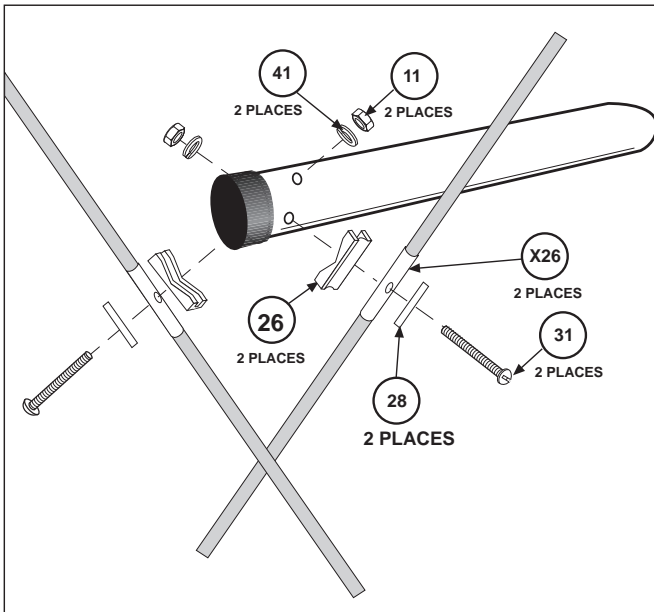
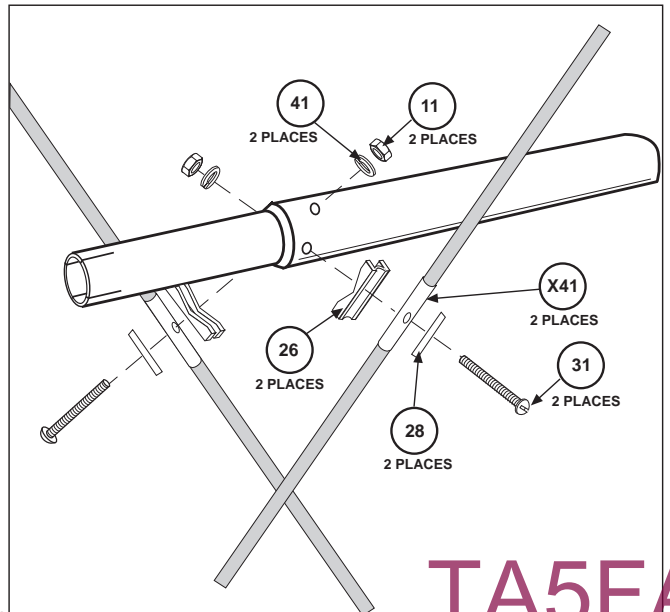


FIGURE 3B



# 4 - ELEMENT MOUNTING

Attach the elements to the boom assembly as shown in Figure 4. Attach element #1 to the end of the boom at 36 inches from the mast clamp. Locate the element next to the black plastic cap. Using the U-bolt (402), element to boom clamp (143), backing plate (33), lock washers (84), and hex nuts (85), fasten the element to the boom. The exposed threads on the element screws (item 31 from section 2) should be facing down and away from the boom.

Attach element #2 to the boom at a distance of 29.5 inches (74.9 cm) from element #1. Using the U-bolt (402), element to boom clamp (143), backing plate (33), lock washers (84), and hex nuts (85), fasten the element to the boom. Note that the exposed threads on the element screws (item 31 from section 2) should be facing away from the boom.

Attach element #3 to the boom at a distance of 55 inches (139.7 cm) from element #2. Using the U-bolt (402), element to boom clamp (143), backing plate (33), lock washers (84), and hex nuts (85), fasten the element to the boom.

Check each X-hat assembly to insure that the rods are located at 45 degrees relative to the boom. If the rods are not at 45 degrees, loosen the appropriate worm clamps and rotate the elements to achieve the correct angle. If necessary, rotate the trap bodies to align the drain holes facing downwards. Tighten all worm clamps once the X-hat rods and traps have been rotated to the correct position.

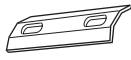




KEY	P/N	DISPLAY	DESC	SIZE	QTY
33	190033		BACKING PLATE	1" x 3-1/2" (2.5 x 8.9 cm)	3
84	010084		LOCK WASHER	1/4" (.6 cm)	6
85	010085		HEX NUT	1/4" (.6 cm)	6
143	190143		ELEMENT TO BOOM CLAMP	3-1/2" x 1-3/8" (8.9 x 3.5 cm)	3
402	010402		U-BOLT	1/4" -20 x 1-3/4"	3

FIGURE 4

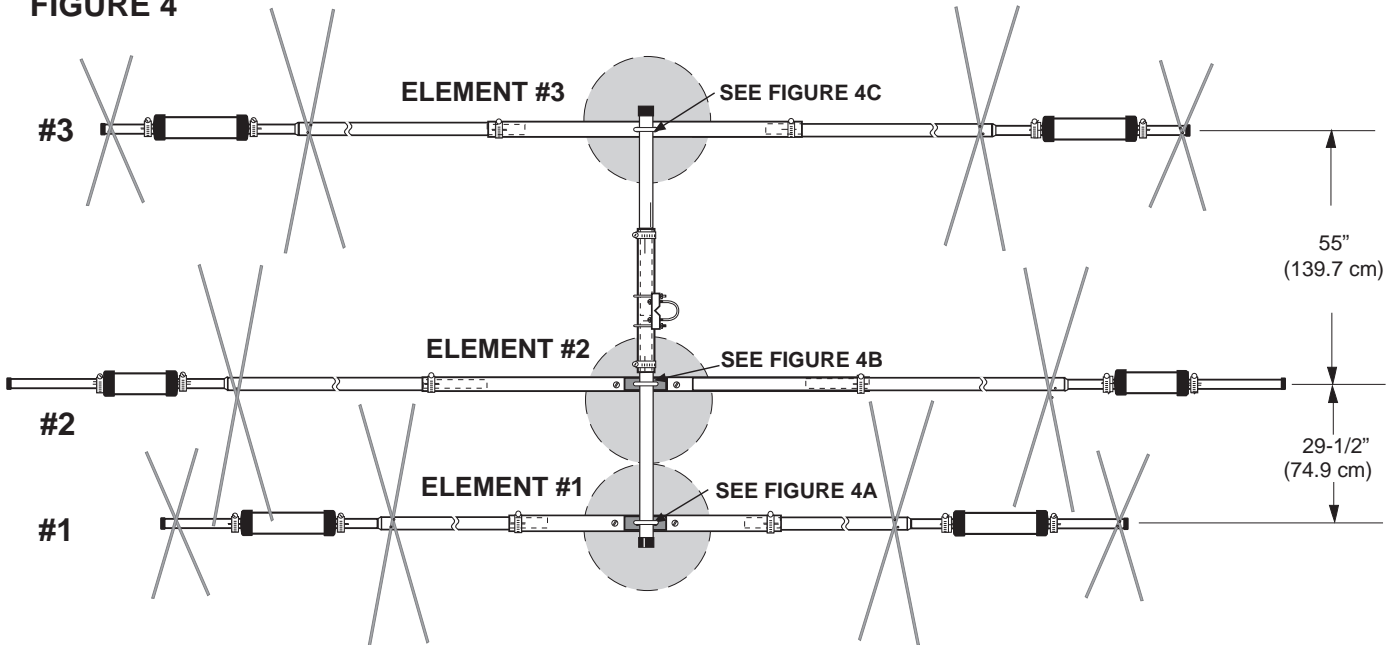
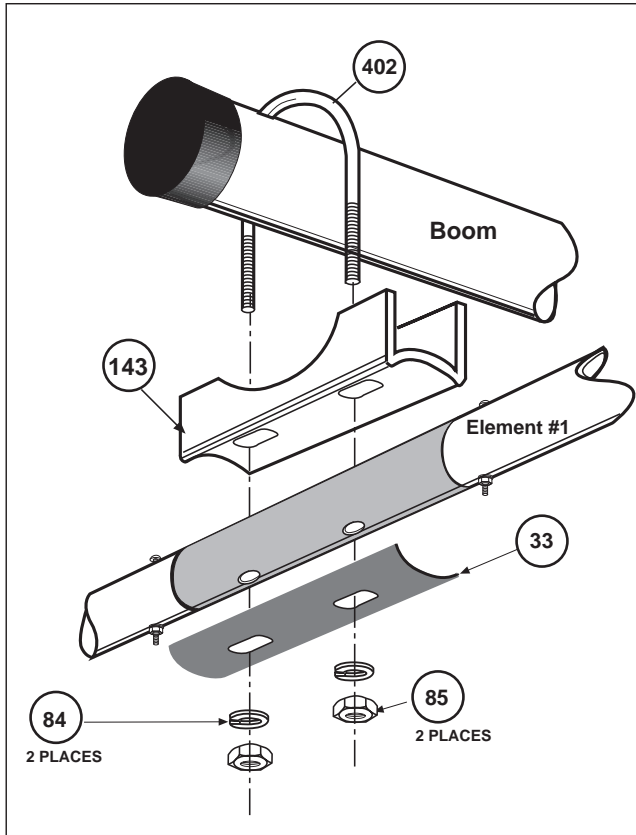




FIGURE 4A



## 4 - ELEMENT MOUNTING Cont.

FIGURE 4B

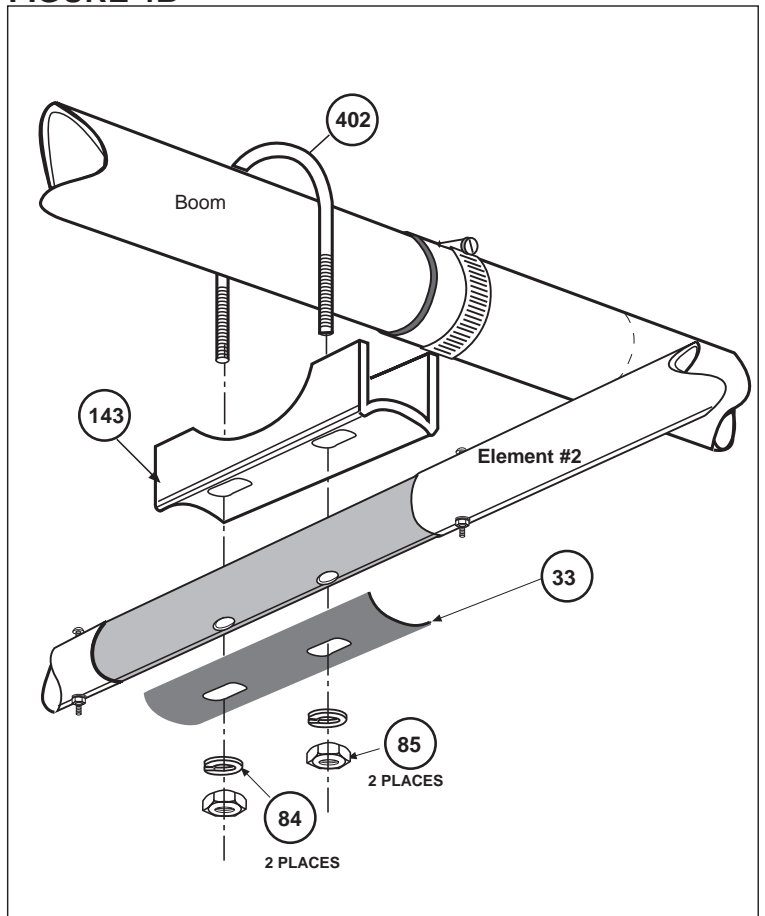
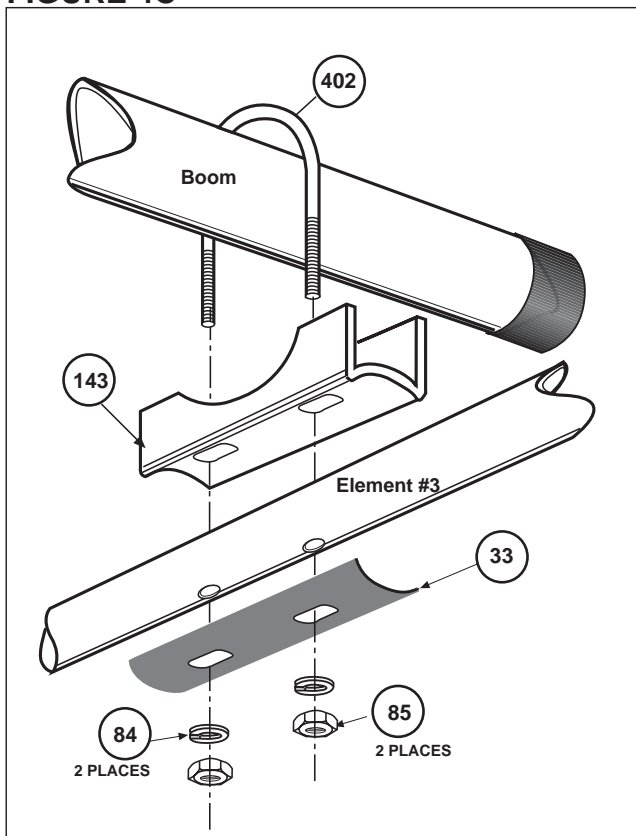







FIGURE 4C

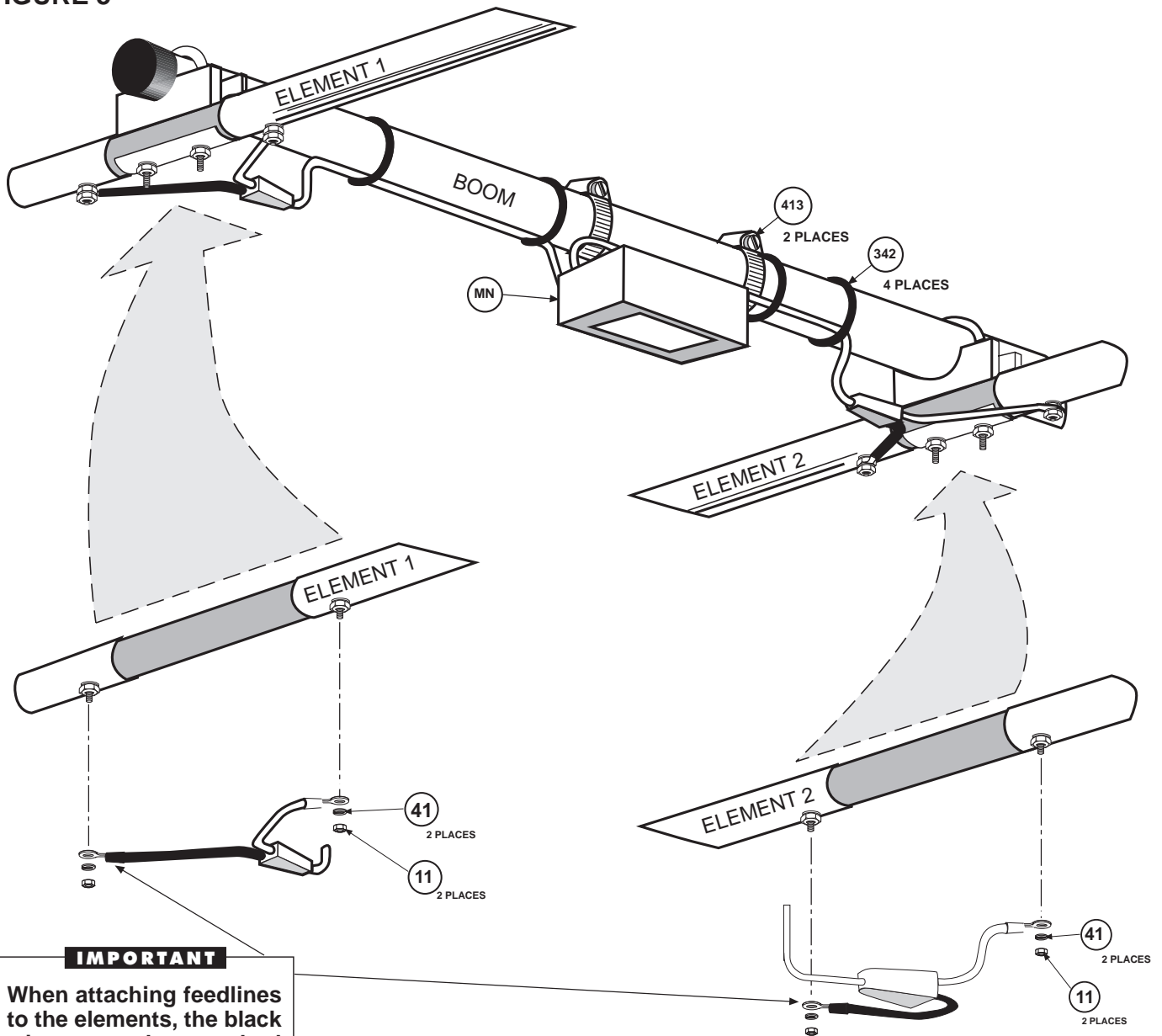


# 5 - MATCHING NETWORK

Install the matching network (MN) to the boom as shown in Figure 5. Loosely attach the worm clamps (413) around the brackets on the matching network and boom section. Attach the feed wires to elements #1 and #2 as shown in the figure. Either cable may be attached to either element, however, the polarity of the wires must be matched on each element (i.e. the red wire on each element must be on the left side and the black wire must be on the right side). Attach the wires using lock washers (41) and hex nuts (11). Slide the matching network to prevent over stressing the cables and tighten the worm clamps. Attach cable ties (342) in 4 places around the cables and tighten.

KEY	P/N	DISPLAY	DESC	SIZE	QTY
11	010011		HEX NUT	#8-32	4
41	011941		LOCK WASHER	#8-32	4
342	030342		CABLE TIE		4
413	030413		WORM CLAMP	1-3/4" (4.4 cm)	2
MN	MN5B		MATCHING NETWORK		1

**FIGURE 5**



**IMPORTANT**  
When attaching feedlines to the elements, the black wires must be attached to the same sides.

## 6 - BOOM TO MAST ASSEMBLY

Before installing the antenna on the mast, check all hardware and worm clamps to insure they are tight. Install the antenna on the mast as shown in Figure 6. Using U-bolts (404), lock washers (19), and hex nuts (18), fasten the antenna to the mast. Place the connector boot (115) on the coax cable before assembly. Apply silicone sealant (116) to the threads of the matching network RF connector and tighten the cable to the matching network. Do not apply silicone to the center conductor or dielectric of either connector. Slide the boot over the connector. Place the coaxial cable over the top of element #2 on the boom and run the cable down the mast to the radio equipment.





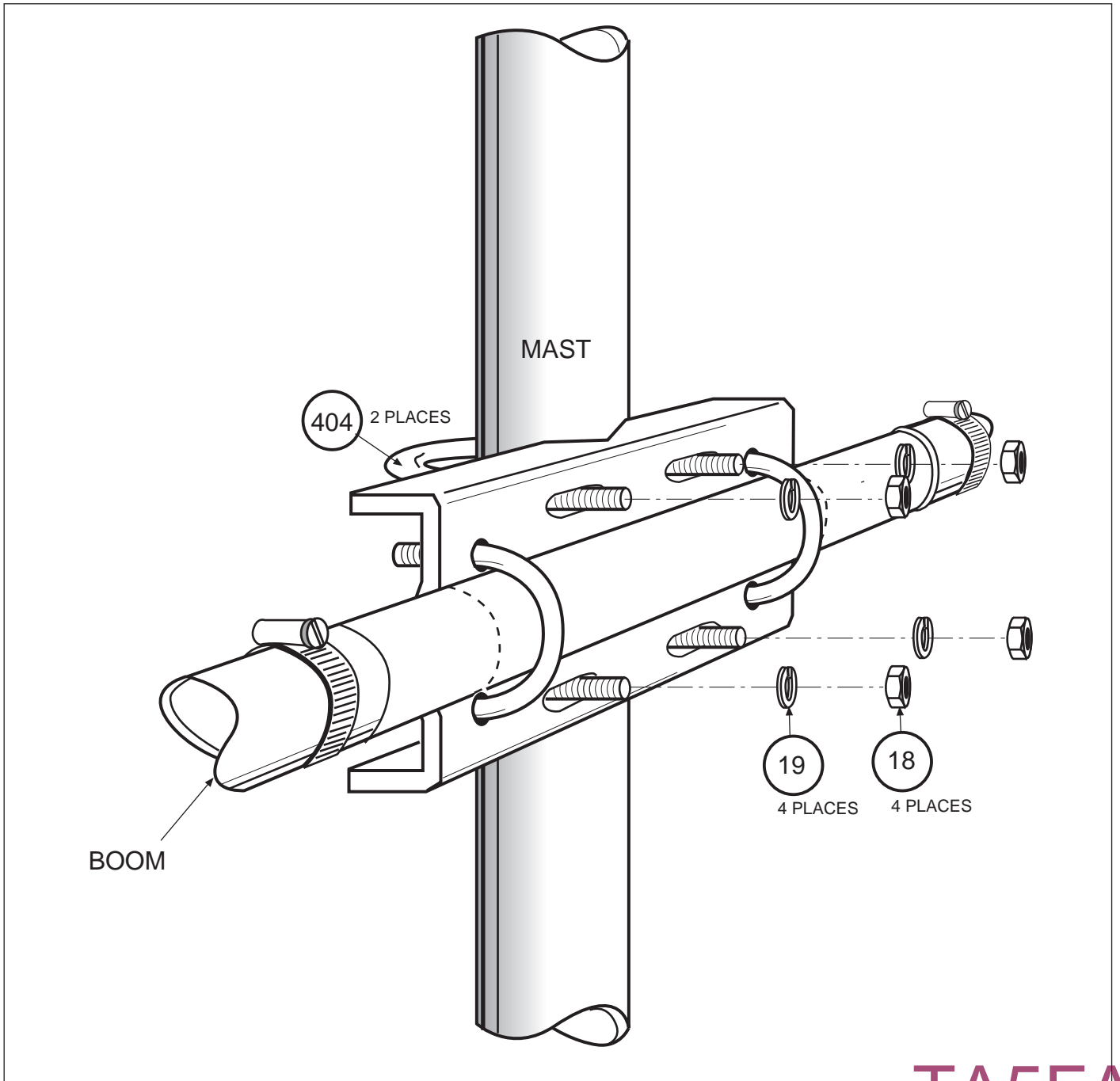
KEY	P/N	DISPLAY	DESC	SIZE	QTY
18	010118		HEX NUT	5/16"	4
19	010119		LOCK WASHER	5/16"	4
115	050115		CONNECTOR BOOT		1
116	240116		SILICONE PACKAGE		1
404	010404		U-BOLT	5/16-18 x 2-1/2" (6.4 cm)	2

FIGURE 6



## MA5B

### SPECIFICATIONS

Model	MA5B				
Frequency Ranges	10	12	15	17	20 meters
Elements	2	1	2	1	2 per band
Gain	5.3	1.0	4.8	1.0	3.6 dBi
Front to Back Ratio	10	0	12	0	22 dB
Sidelobe Attenuation	25	25	25	25	25 dB
VSWR 2:1 Bandwidth	665	>110	225	>100	90 kHz
Longest Element	17.1ft. (5.2m)				
Turning Radius	8.8 ft. (2.7m)				
Boom Length	7.3 ft. (2.2m)				
Boom Diameter	1.5in. (3.8cm)				
Max. Wind Surface Area	3.22ft <sup>2</sup> (.3m <sup>2</sup> )				
Max. Power Handling	1.2 kw				
Weight	26.5 lbs. (12kg)				

The Electrical Specifications for all Cushcraft Amateur Antennas are derived from numerical analysis and measured data taken on our test range. Performance may vary due to the random variables associated with a specific application or installation.

#### LIMITED WARRANTY

Cushcraft Corporation, 48 Perimeter Road, Manchester, New Hampshire 03103, warrants to the original purchaser for one year from date of purchase that each Cushcraft antenna is free of defects in material or workmanship. If, in the judgement of Cushcraft, any such antenna is defective, then Cushcraft Corporation will, at its option, repair or replace the antenna at its expense within thirty days of the date the antenna is returned (at purchasers expense) to Cushcraft or one of its authorized representatives. This warranty is in lieu of all other expressed warranties, any implied warranty is limited in duration to one year. Cushcraft Corporation shall not be liable for any incidental or consequential damages which may result from a defect. Some states do not allow limitations on how long an implied warranty lasts or exclusions or limitations of incidental or consequential damages, so the above limitation and exclusion may not apply to you. This warranty gives you specific legal rights, and you may also have other rights which vary from state to state. This warranty does not extend to any products which have been subject the misuse, neglect, accident or improper installation. Any repairs or alterations outside of the Cushcraft factory will nullify this warranty.



48 PERIMETER ROAD, MANCHESTER, NH 03103 USA  
TELEPHONE: 603-627-7877 • FAX: 603-627-1764 • E-mail: techsup@cushcraft.com

SPECIFICATIONS SUBJECT TO CHANGE WITHOUT NOTICE

# TA5FA