

**ASSEMBLY AND INSTALLATION  
INSTRUCTION**

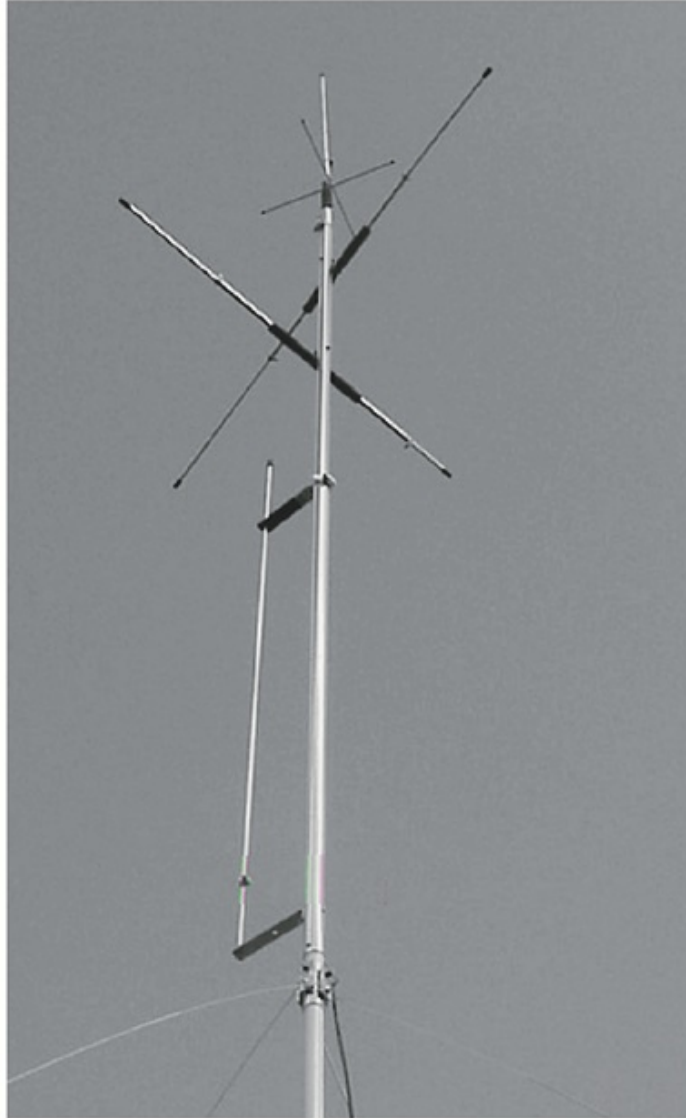

**MA6V**

**6 Band High-Performance  
Mini-Vertical Antenna**



48 PERIMETER ROAD, MANCHESTER, NH 03103 603-627-7877 / FAX 603-627-1764 [www.cushcraft.com](http://www.cushcraft.com)

**TA5FA**  
951528\_GF\_AA

# MA6V

## WARNING

THIS ANTENNA IS AN ELECTRICAL CONDUCTOR. CONTACT WITH POWER LINES CAN RESULT IN DEATH, OR SERIOUS INJURY. DO NOT INSTALL THIS ANTENNA WHERE THERE IS ANY POSSIBILITY OF CONTACT WITH OR HIGH VOLTAGE ARC-OVER FROM POWER CABLES OR SERVICE DROPS TO BUILDINGS. THE ANTENNA, SUPPORTING MAST AND/OR TOWER MUST NOT BE CLOSE TO ANY POWER LINES DURING INSTALLATION, REMOVAL OR IN THE EVENT PART OF THE SYSTEM SHOULD ACCIDENTALLY FALL. FOLLOW THE GUIDELINES FOR ANTENNA INSTALLATIONS RECOMMENDED BY THE U.S. CONSUMER PRODUCT SAFETY COMMISSION AND LISTED IN THE ENCLOSED PAMPHLET.

Your Cushcraft antenna is designed and manufactured to give top performance and trouble free service. The antenna will perform as specified if the instructions and suggestions are followed and care is used in assembly and installation. When checking the components received in your antenna package, use the parts lists in each section. It is easiest to identify the various dimensions of tubing by separating them into groups of the same diameter and length. If you are unable to locate any tube or component, check the inside of all tubing. IMPORTANT: save the weight label from the outside of the carton. Each antenna is weighed at the factory to verify the parts count. If you claim a missing part, you will be asked for the weight verification label. There is a master parts list on page 3.

## LOCATION

To prevent detuning, install the MA5V in an open area clear of metal buildings, guy wires, towers, and dipole feedlines.

Important Warning: Never mount your antenna where humans and pets may contact it accidentally. Protruding elements and hardware can cause injury and contact with energized conductors may inflict severe RF burns. Also, transmitting antennas may expose humans to intense RF fields. The medical effects of RF exposure are unknown, but may be harmful. U.S. amateurs are required to comply with FCC exposure-safety guidelines (for more information, see the FCC web site at [www.fcc.gov/oet/rfsafety](http://www.fcc.gov/oet/rfsafety) and ARRL web site at [www.arrl.org/news/safety](http://www.arrl.org/news/safety)). Amateurs in other countries may also be subject to governmental standards (check publications for your region). Never install antennas without assistance. Plan work carefully and use only qualified persons to monitor or assist. If in doubt about safety obtain the services of a professional installer.

## MOUNTING

The MA6V accepts mast diameters to 2.0" OD (5.1 cm). To prevent injury and minimize ground losses, always mount at least 10-12 feet above the surface. For best DX performance, mount high and in-the-clear. Because of its light weight, the MA6V may be roof-mounted with conventional TV hardware. However, avoid installing near conductive guy wires—these may couple to the lower element and detune the antenna. Also, do not mount next to parallel vertical conductors such as dipole feedline drops, other masts, metal chimneys, and utility poles.

## SYSTEM GROUNDING

To ensure lightning-strike protection, always disconnect the feedline from its building-entrance when the antenna is not in use. For backup protection from unexpected nearby strikes, install a quality lightning arrester such as the Cushcraft LAC4.

## ASSEMBLY

Assemble carefully following all directions, photos, and illustrations. Before mounting, verify each part was installed correctly and check all hardware for tightness.

## FEEDLINE SELECTION

Feedline losses are inevitable, and a small amount is even beneficial because it enhances the antenna's bandwidth without noticeably degrading performance. However, to ensure best results, avoid long runs of lossy cable or short runs of low-loss cable. We recommend the following:

1. RG-58 for runs up to 75'
2. RG-8X (Mini-8) for 50-150 foot runs.
3. RG-8 or RG-213 for longer runs.

## TUNING PROCEDURE

As needed, fine-tune resonator stubs to compensate for varied mounting locations or to provide best SWR in a favorite band segment. When adjusting, use the same feedline you plan to install permanently. MA5V resonators are labeled by band. Lengthen to lower frequency and shorten to raise frequency (interaction between resonators is minimal). A handheld SWR analyzer speeds fine-tuning.

## PRECIPITATION

A buildup of precipitation will lower resonant frequency (a condition common to most antennas). If SWR exceeds 2:1 due to precipitation loading, you may use an antenna tuner (ATU) to temporarily correct the problem. Alternatively if you live in a wet region, consider tuning resonators slightly high to provide built-in compensation for when it rains or snows.

## RF POWER RATING

The MA6V will safely handle up to 250 Watts pep on SSB, but power should not exceed 100 Watts for high duty-cycle modes such as AM, FM, RTTY, and PSK. Important Warning: Never use a high-power linear amplifier with this antenna. Permanent damage to the sealed resonator coils may result.

## SPECIFICATIONS

| MODEL                    | MA6V                        |
|--------------------------|-----------------------------|
| Frequency Meters:        | 20, 17, 15, 12, 10, 6       |
| Gain:                    | 1-2 dBi                     |
| SWR Minimum:             | <1.2:1 All Bands            |
| Power Rating, Watts PEP: | 250 SSB                     |
| Dimensions:              | 14.7' (4.48m) High          |
| Mast Size:               | 1.25 - 2.0" (3.18 - 5.1 cm) |
| Wind Survival, mph:      | >80                         |
| Weight lb. (kg):         | 6.9 (3.13)                  |
| Hardware:                | Stainless Steel             |

# TA5FA

## MASTER PARTS LIST

| KEY | PART #   | DESCRIPTION                             | QUANTITY |
|-----|----------|---|----------|
| 01  | 125401   | Coaxial balun form                      | 1        |
| 02  | 035402   | 3/16" Nylon cable clamp                 | 2        |
| 07  | 030407   | 7/32" - 5/8" worm clamp                 | 6        |
| 11  | 010011   | #8-32 Nut                               | 19       |
| 12  | XHR12    | 12" Long X-hat rd                       | 2        |
| 20  | 010120   | 8-32 x 2" RH slotted machine screw      | 6        |
| 26  | 290326   | Danger label                            | 5        |
| 29  | 010229   | #8-32 x 1" SS RH machine screw          | 2        |
| 31  | 010231   | #8-32 x 1-3/4" RH machine screw         | 2        |
| 32  | 902832   | 49" SS whip & tip assembly              | 4        |
| 40  | 010040   | #8-32 x 1-1/4" Screw                    | 2        |
| 41  | 011941   | #8 SS split lock washer                 | 10       |
| 44  | 014544   | #8 SS flat washer                       | 14       |
| 45  | 321045   | Aluminum spacer                         | 2        |
| 53  | 193853   | Aluminum Bracket                        | 1        |
| 60  | 205560   | MA5V6M Insulator Plate                  | 1        |
| 61  | 195651   | MA5V6M Bracket                          | 1        |
| 68  | 053368   | .156ID x 1/4" long black vinyl cap      | 4        |
| 77  | 050077   | 3/8" x 7/8" black plastic cap           | 6        |
| 84  | 010084   | SS Split Lock Washer 1/4"               | 1        |
| 85  | 010085   | SS Hex Nut, 1/4" x 20                   | 2        |
| 984 | 082984   | Threaded Aluminum Rod 1/4"-20 x 13-1/4" | 1        |
| 96  | 010096   | SSRH Machine Screw, #8-32 x 3/8"        | 1        |
|     | MA5V6MEA | MA5V6M Element EA, 47"                  | 1        |
| 93  | 195393   | Radial rod clamp                        | 8        |
| 411 | 030411   | 9/16"-1-1/4" worm clamp                 | 2        |
| BA  | MA5VBA   | MA5V base tube                          | 1        |
| BB  | MA5VBB   | MA5V insulated base section             | 1        |
| BC  | MA5VBC   | MA5V tube BC                            | 1        |
| BD  | MA5VBD   | MA5V tube BD                            | 1        |
| EA  | MA5VEA   | MA5V element #A                         | 1        |
| EB  | MA5VEB   | MA5V element #B                         | 1        |
| EC  | MA5VEC   | MA5V element #C                         | 1        |
| ED  | MA5VED   | MA5V element #D                         | 1        |
| EE  | MA5VEE   | MA5V element #E                         | 1        |
| RA  | MA5VRA   | MA5V 10M/12M resonator assembly         | 1        |
| RB  | MA5VRB   | MA5V 15M/17M resonator assembly         | 1        |
| RC  | MA5VRC   | MA5V 20M resonator assembly             | 1        |
| RS  | MA5VRS   | MA5V radial sleeve                      | 1        |
| FL  | MA5VFL   | MA5V feed-line                          | 1        |
| HK  | GOMNIHK  | Omni mounting kit                       | 1        |

**Important Note:** Unless otherwise noted, all hardware used in assembly will be #8-32 Stainless Steel

**Step #1 Wind and Mount Coaxial Choke:**

Find the 54" fiberglass insulated tube (MA5BB). Also, find two 2" screws (20) and two nuts (11). Locate choke mounting holes 9-1/2" apart on base end (Photo-1) Install a 2" screw in each hole and secure with a nut as shown.

Find the 1-1/8" x 12" aluminum base tube (MA5BA). Also find one 1-1/4" screw (40) and one nut (11). Slide the slotted end of the aluminum base tube over the fiberglass tube and align mounting holes. Install a screw and nut at the top mounting hole and tighten so the slotted tube compresses onto the insulated mast (Photo-2) The second mounting screw will be installed later.

Find two 1/2" OD x 5/16" aluminum spacers (45). Install one over each mounting screw so it clears the nut (Photo-3).

Find the 2-3/8" OD x 10-1/4" PVC balun form (01). Slide form over the end of the mast and seat into position so it rests on the spacers (Photo-4)

Find the 34' roll of RG-58AU coaxial cable (MA6VFL), also, find two 3/16" nylon cable clamps (02), two flat washers (44), and two nuts (11). Locate the tail end of the coax cable, which has the spade lugs, and measure 38" down from the end. Install a nylon cable clamp at this location. Install the cable and its clamp as shown in Photo-5, securing in place with a flat washer and a nut.

Uncoil and lay out the opposite end of the feedline, removing any bends or loops that could interfere with winding the balun. To wind, rotate the coil form and mast with one hand, while guiding turns into place with the other (Photo-6)

Wind until the last turn falls 1/2" from the opposite mounting stud. Turns should be tight with no open areas between windings. Install the remaining cable clamp and secure in place with a flat washer and nut (Photo-7).

**Step- #2 Install Mounting Hardware:**

Find two extruded aluminum "V" blocks and the mast-mount hardware kit (GOMNIHK). Open the plastic bag and separate the smaller 1/4" hardware from the larger 5/16" hardware.

Using 1/2" hardware, install the mast-mount blocks approximately 10" apart on the support tube, as shown in Photo-8. Align the lower block with the upper block by sighting down between the narrow splits in the mounting rings while tightening hardware.

You may install the 5/16" U-bolt hardware temporarily at this time, or set it aside until the antenna is ready to mount on a support.

Find a 1-1/4" screw (40) and nut (11). Install in the base tube's remaining mounting hole and tighten securely (Photo-9)

**Photo-1**

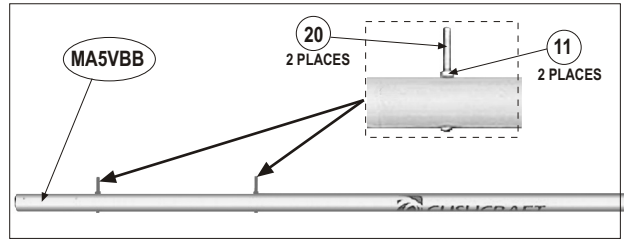

**Photo-2**

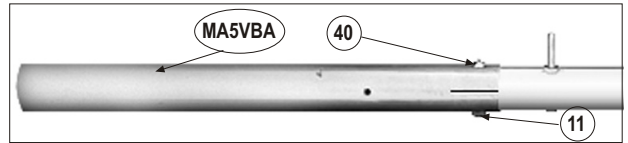

**Photo-3**

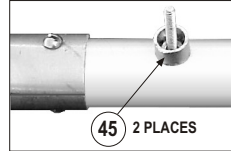

**Photo-4**



**Photo-5**

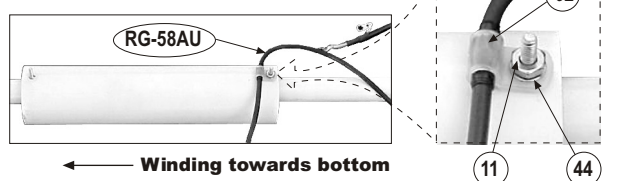

**Photo-6**

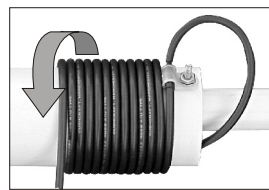

**Photo-7**

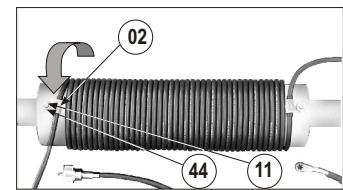

**Photo-8**

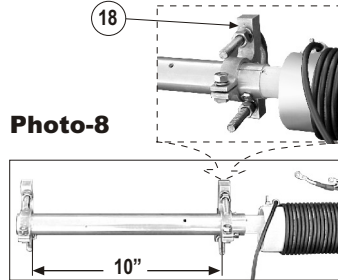

**Photo-9**

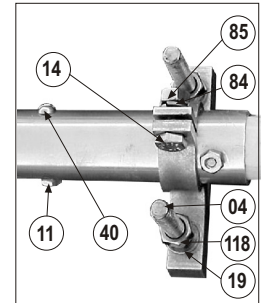

| KEY | P/N    | DISPLAY | DESC              | SIZE            | QTY |
|-----|--------|---------|-------------------|-----------------|-----|
| BB  | MA5VBB |         | Insulated Base    | 1" x 54"        | 1   |
| 20  | 010120 |         | RH Machine screw  | 8-32 x 2"       | 2   |
| 11  | 010011 |         | Hex nut           | #8-32           | 18  |
| BA  | MA5VBA |         | Base tube         | 1-1/8" x 12"    | 1   |
| 40  | 010040 |         | RH Machine screw  | #8-32 x 1-1/4"  | 2   |
| 45  | 321045 |         | Aluminium spacer  | 1/2" OD x 5/16" | 2   |
| 01  | 125401 |         | Balun form        | —               | 1   |
| FL  | MA5VFL |         | Feedline cable    | 34'             | 1   |
| 02  | 035402 |         | Nylon cable clamp | 3/16"           | 2   |
| 44  | 014544 |         | Flat washer       | 1/4"            | 2   |

**GOMNIHK KIT**  
(Omni mounting kit)

| KEY | P/N    | DISPLAY | DESC             | SIZE  | QTY |
|-----|--------|---------|------------------|-------|-----|
| 14  | 010214 |         | Hex screw        | 1/4"  | 2   |
| 84  | 010084 |         | Lock washer      | 1/4"  | 2   |
| 85  | 010085 |         | Nut              | 1/4"  | 2   |
| 18  | 323718 |         | Aluminium Vblock | —     | 2   |
| 04  | 010404 |         | U-bolt           | 5/16" | 2   |
| 118 | 010118 |         | Nut              | 5/16" | 2   |
| 19  | 010119 |         | Lock washer      | 5/16" | 2   |

### Step #3 Install Lower-Element Mounting Hardware:

Find the 1-1/8" OD x 3" radial sleeve (MA5VRS). With the mounting holes closest to the top (Photo-10), slip over the mast and align with the 4 pair of mounting holes, as shown.

Find eight X-pattern radial clamps (93). Also, find four 2" screws (20), four lockwashers (41), nine flat washers (44), and five nuts (11).

Lay two radial clamps face-to-face to form a round mounting channel for the radial rods. Install two mounting screws and place a flat washer over each (Photo-11). Insert the screws through the radial sleeve and mast. Place a flat washer over each screw where it protrudes through the mast.

Lay two more radial clamps face-to-face and install over the mounting screws. Install a lock-washer on each and secure in place finger-tight with nuts (Photo-12).

Repeat the above procedure, installing the remaining four radial clamps finger-tight temporarily secure the shield of the coax to one of the upper mounting screws using the left-over flat washer and nut (Photo-13).

The four 49" whips making up the lower element will be installed last, when other work on the main element is complete.

### Step #4 Install Upper Element:

Find the 1-1/8" x 48" element tube (MA5VBC). Also find two 1-3/4" screws (31), two lockwashers (41), one flat washer (44), and three nuts (11).

Slide the drilled and slotted end of the element over the mast and align the mounting holes (Photo-14). Install the 1-3/4" screw in the upper mounting hole. Secure in place with a lockwasher and nut.

Install the remaining 1-3/4" screw in the lower mounting hole and secure in place with a lockwasher and nut, compressing the slotted tube against the insulated mast.

Temporarily install the coax center-conductor on the lower mounting screw using the remaining flat washer and nut.

Find the 1" x 48" aluminum tube (MA5VBD) and one large worm clamp (411). Slip the clamp onto the slotted end of the lower tube. Install the upper tube for an extended length of 40" and tighten (Photo-15).

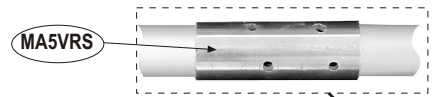

Photo-10



Photo-11

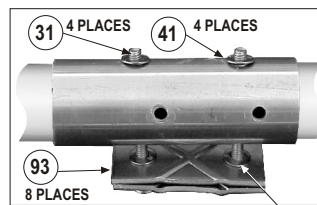

Photo-12

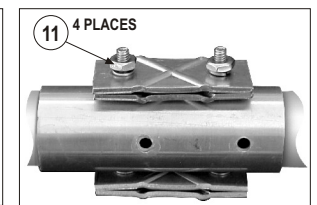

Photo-13

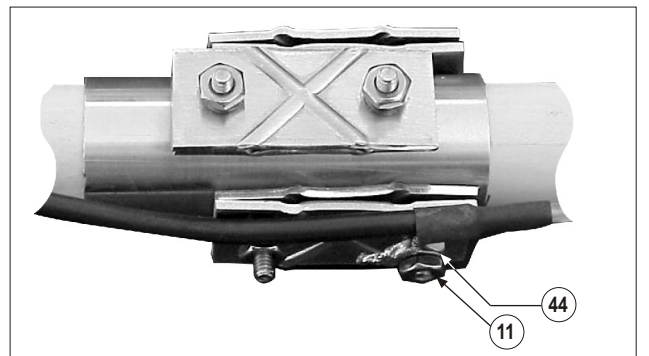

Photo-14

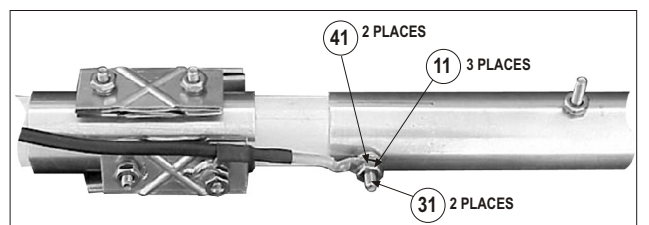
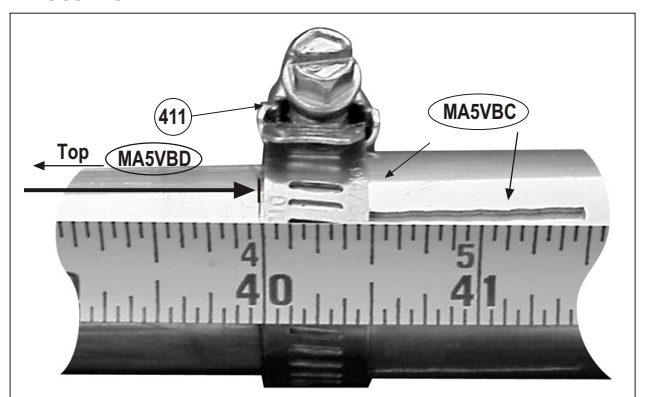

Photo-15



| KEY | P/N    | DISPLAY | DESC             | SIZE           | QTY |
|-----|--------|---------|------------------|----------------|-----|
| RS  | MA5VRS |         | Radial Sleeve    | —              | 1   |
| 93  | 195393 |         | Radial rod clamp | —              | 8   |
| 31  | 010231 |         | RH machine screw | #8-32 x 1-3/4" | 2   |
| 20  | 010120 |         | RH machine screw | #8-32 x 2"     | 4   |
| 41  | 011941 |         | Lock washer      | #8             | 6   |
| 44  | 014544 |         | Flat washer      | #8             | 10  |
| 11  | 010011 |         | Hex nut          | #8-32          | 8   |
| BC  | MA5VBC |         | Aluminium tube   | 1-1/8" x 48"   | 1   |
| BD  | MA5VBD |         | Aluminium tube   | 1" x 48"       | 1   |
| 411 | 020411 |         | Large worm clamp | —              | 1   |



### Step #5 Assemble and Install 20-Meter Resonator Coil and X-Hat:

Find the 20-Meter resonator assembly (MA5VRC) and two 3/16" OD x 12" center-drilled X-hat rods (XHR12). Also, find two 1" screws (29), two lockwashers (41) and two nuts (11).

Install X-Hat rods as shown in Photo-16. Note that each pair of mounting holes are "step drilled" (one hole is larger than the other). Place the hat rod over the larger hole to lock it into position and secure in place with a screw, lockwasher, and nut.

Find four flexible vinyl caps (68) and a small worm clamp (07). Install a cap on the tip of each X-Hat rod. Also, install the small worm clamp on the top section of the resonator (Photo-17).

Find a large worm clamp (411). Slide clamp on the slotted end of the 1" element tube and install coil assembly for an extension length of 2-1/2" (Photo-18)

Photo-18



Photo-16

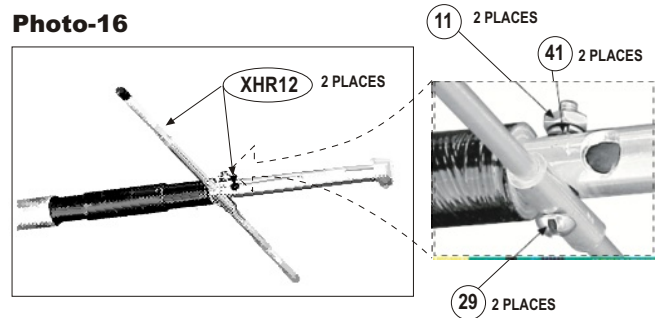
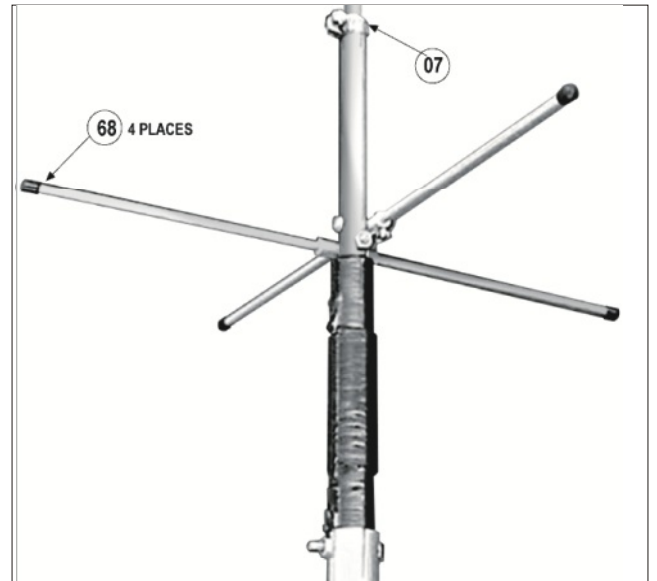

Photo-17



### Step #6 Install 10/12-Meter and 15/17-Meter Resonator Assemblies:

Find the 10/12-Meter resonator assembly (MA5VRA) and the 15/17-Meter resonator assembly (MA5VRB). Also find four small worm clamps (07) and two nuts (11).

Locate the lower of the two resonator-mounting holes on upper element tube MA5VBD (21-1/2" below top lip of tube). Mount the 10/12-Meter coil assembly — as shown in Photo -19— using a nut (resonators are labeled by band). Install a worm clamp loosely on each end.

In similar fashion, locate the higher of the two resonator-mounting holes (6-1/2" below top lip of tube), and mount the 15/17-Meter resonator coil assembly. Install worm clamps.

Photo-19

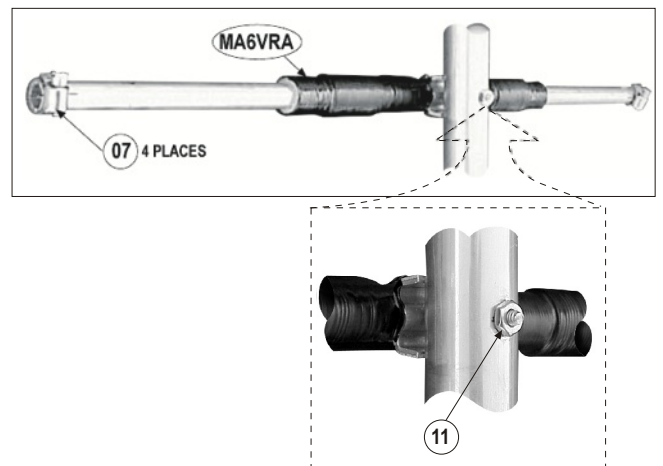

| KEY | P/N    | DISPLX | DESC               | SIZE            | QTY |
|-----|--------|--------|--------------------|-----------------|-----|
| RC  | MA5VRC |        | Resonator assembly | 20 Meter        | 1   |
| 12  | HXR12  |        | X-hat rod          | 12"             | 2   |
| 29  | 010229 |        | RH machine screw   | #8-32 x 1"      | 2   |
| 41  | 011941 |        | Split lock washer  | #8-32           | 6   |
| 11  | 010011 |        | Hex nut            | #8-32           | 4   |
| 68  | 053368 |        | Vinyl caps         | .156" ID x 1/4" | 4   |
| 07  | 030407 |        | Small worm clamp   | -----           | 5   |
| 411 | 030411 |        | Large worm clamp   | -----           | 1   |
| RA  | MA5VRA |        | Resonator assembly | 10/12 meter     | 1   |
| RB  | MA5VRB |        | Resonator assembly | 15/17 meter     | 1   |

**Step #7 Install and Pre-set Resonator Element Tubes:**

Find the five 3/8" OD resonator tubes: 21" (MA5VEE), 18" (MA5VED), 14" (MA5VEC), 12" (MA5VEB), and 6" (MA5VEA). Also, find five 3/8" ID black-plastic end caps (77)

Install a 21" tube in the 20-Meter resonator adjust for 18-1/4" extension, and tighten. (Photo-20)

Locate the 10-Meter resonator (marked) and install the 6" resonator tube for 3-3/8" extension (Photo-21) Tighten worm clamp.

Install a 12" tube in the 12-Meter resonator adjust for 9-1/4" extension, and tighten.

Install a 14" tube in the 15-Meter resonator adjust for 10-1/4" extension, and tighten.

Install a 18" tube in the 17-Meter resonator adjust for 14" extension, and tighten.

Install a black-plastic end cap on the end of each tube.

**Photo-20**

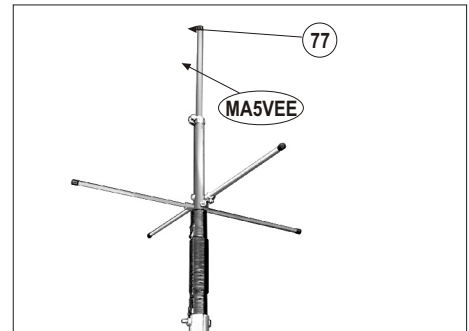

**Photo-21**

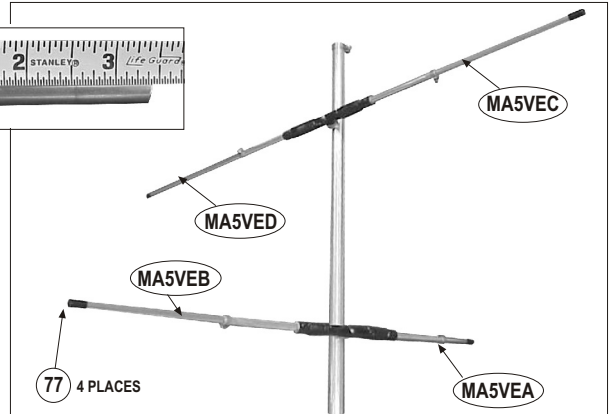

**Step-8, Install 6 Meter Resonator**

In some applications (backpacking, camping, etc.), the MA5V may be easier to transport and faster to set up without the six-meter resonator installed. If six-meter operation is not required, you may omit Step-8 and proceed to Step-9.

Find two 1/4" nuts (85), a 1/4" lock washer (84), the element base rod (984) and base bracket (61).

Install a 1/4" nut and lock washer on threaded end of rod. Install bracket using a second nut to secure firmly in place (see Photo 22).

Using existing hardware, install base bracket assembly on the existing #8 screw located approximately 6" above the feedpoint on tube MA5BC.

Find plastic insulator plate (60), two 8-32 x 3/8" screws (96), two #8 flat washers (44), two #8 lock washers (41), and two 8-32 nuts (8). Also, find the upper mounting bracket (53).

Place a flat washer on each screw, then install through the plastic insulator and bracket as shown (Photo 23). Fasten in place with lockwashers and nuts, then tighten securely.

Find the 47" six-meter resonator tube (MA5V6MEA). Install the upper bracket by sliding it over the tube to a position approximately 6" below the end of the tube .

Find the 3/8" end cap (77) and the small worm clamp (07). Install the small worm clamp loosely on the slotted end of the tube. Install the end cap on the unslotted (opposite) end, seating firmly in place (see Photo-24).

Slide the slotted end of the element tube onto the base rod and secure temporarily with the small worm clamp.

The large worm clamp that secures tube MA5BD to MA5BC on the main mast is also used to clamp the six-meter upper element bracket in place. Loosen the large worm clamp (without changing extension length). Align the upper bracket with the lower, slip it under the large worm clamp, and loosely secure in place.

Rotate upper tube MA5VBD so the 10/12-meter resonator arm is 90-degrees off-axis from the six-meter element bracket (see Photo-25). When in position, fully tighten the worm clamp to secure the top section and bracket in place permanently.

On a test MA6V, minimum SWR was obtained with the resonator settings shown below in the Tuning Chart. Minor adjustments may be required, depending on mounting location and surroundings.

**Photo-22**

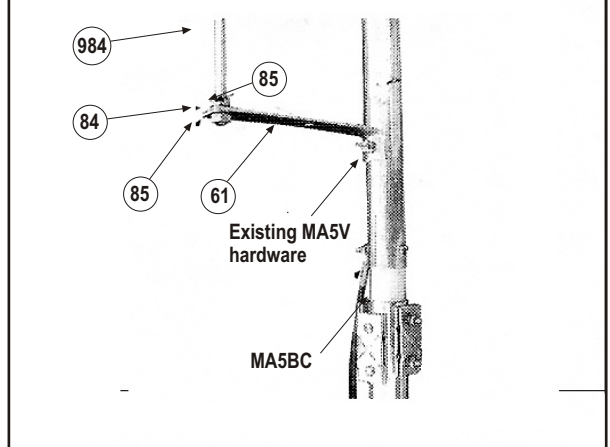



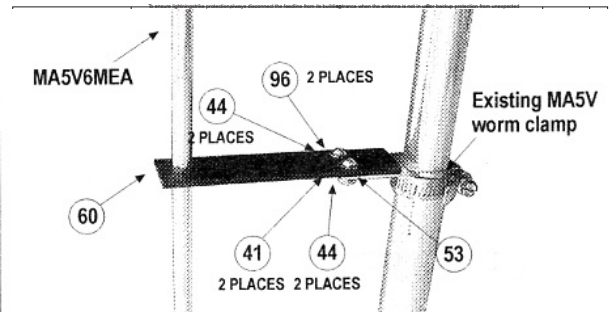









**Photo-23**



## Step-8, Install 6 Meter Resonator:

### Tuning Chart

|            |                                |                           |
|------------|--------------------------------|---------------------------|
| 50.150 MHz | (CW/SSB/AM portion of band)    | 52-3/4"                   |
| 52.525 MHz | (FM simplex calling frequency) | 49-3/4"                   |
| 52.54 MHz  | (Standard FM repeater pairs)   | 50-1/2" $\varnothing$ 48" |

| KEY      | P/N    | DISPLAY   | DESC                   | SIZE                | QTY |
|----------|--------|---|------------------------|---------------------|-----|
| 07       | 030407 |  | SS Worm Clamp          | 7/32" - 5/8"        | 1   |
| 11       | 010011 |  | SS Hex Nut             | #8-32               | 2   |
| 41       | 014941 |  | SS Split Lock Washer   | #8                  | 2   |
| 44       | 014544 |  | SS Flat Washer         | #8                  | 2   |
| 53       | 193853 |  | Aluminum Bracket       | —                   | 1   |
| 61       | 195561 |  | MA5V6M Bracket         | —                   | 1   |
| 60       | 205560 |  | MA5V6M Insulator Plate | —                   | 1   |
| 77       | 050077 |  | Black Plastic End Cap  | 3/8"                | 1   |
| 84       | 010084 |  | SS Split Lock Washer   | 1/4"                | 1   |
| 85       | 010085 |  | SS Hex Nut             | 1/4" - 20           | 2   |
| 984      | 082984 |  | Threaded Aluminum Rod  | 1/4" - 20 x 13-1/4" | 1   |
| 96       | 010096 |  | SS RH Machine Screw    | #8 - 32 x 3/8"      | 2   |
| MA5V6MEA |        |   | MA5V6M Element EA      | 47"                 | 1   |

## Step-9, Install Lower-Element Rods:

Find four 49" stainless whip-and-tiprods (32). Note that whips should be mounted so they extend outward from the mast in a pinwheel pattern (Photo 26).









Insert two whips in upper opposing clip-pairs—as shown in Photo-25. Loosen hardware and remove coax pigtail for easier installation. Once inserted, tighten hardware securely and re-install coax pigtail.

Insert two whips in the lower set of clips and secure.

Attach all safety warning labels included with your antenna.

This completes assembly of the MA6V 6-band vertical antenna.

**Handling Note:** For convenient handling during installation, you may slide all four whip ends into the feedline choke coil form and use this as a temporary retainer (do not store in this manner for extended periods). Always confirm each whip returns to its original 45-degree angle when released.

| KEY | P/N    | DISPLAY   | DESC          | SIZE            | QTY |
|-----|--------|---|---------------|-----------------|-----|
| EE  | MA5VEE |  | Element tube  | 3/8"OD x 21"    | 1   |
| ED  | MA5VED |  | Element tube  | 3/8"OD x 18"    | 1   |
| EC  | MA5VEC |  | Element tube  | 3/8"OD x 14"    | 1   |
| EB  | MA5VEB |  | Element tube  | 3/8"OD x 12"    | 1   |
| EA  | MA5VEA |  | Element tube  | 3/8"OD x 6"     | 1   |
| 77  | 050077 |  | Black end cap | .156" ID x 1/4" | 5   |
| 32  | 902832 |  | Whip and tip  | -----           | 4   |
| 26  | 290326 |  | Danger label  | -----           | 5   |

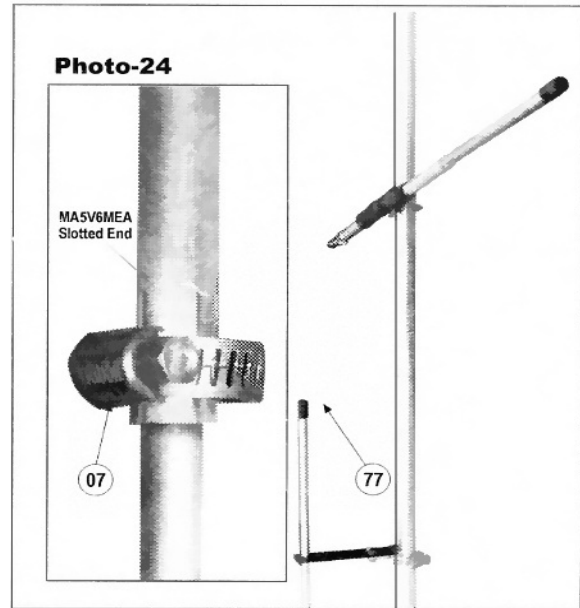

**Note:** Measure from the tip of the resonator rod to the resonator base bracket (see Photo-26).

Photo-25

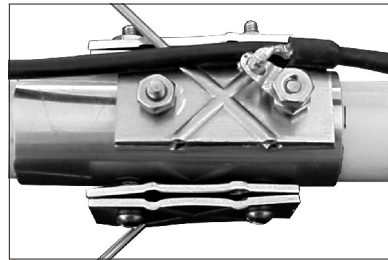

Photo-25  
Top View

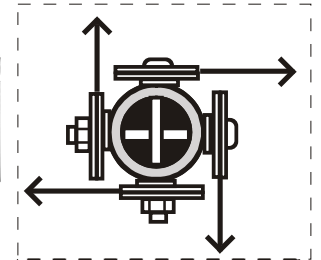
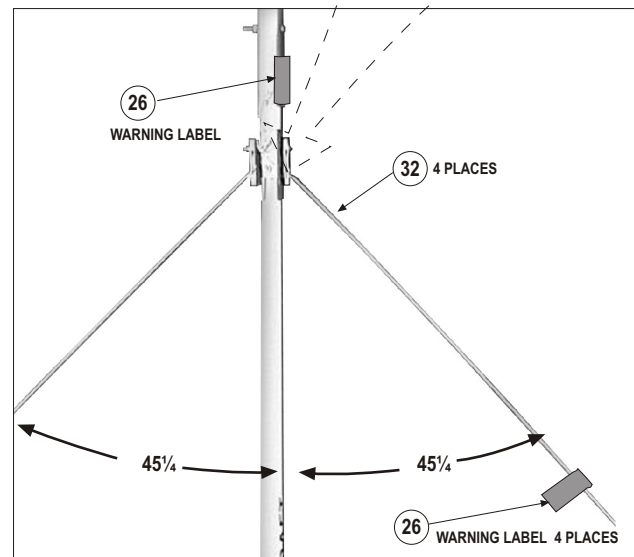

Photo-26



TA5FA



**LIMITED WARRANTY**

CUSHCRAFT CORPORATION, P.O. BOX 4680, MANCHESTER, NEW HAMPSHIRE 03108, WARRANTS TO THE ORIGINAL CONSUMER PURCHASER FOR TWO YEARS FROM DATE OF PURCHASE THAT EACH CUSHCRAFT ANTENNA IS FREE OF DEFECTS IN MATERIAL OR WORKMANSHIP. IF, IN THE JUDGMENT OF CUSHCRAFT, ANY SUCH ANTENNA IS DEFECTIVE, THEN CUSHCRAFT CORPORATION WILL, AT ITS OPTION, REPAIR OR REPLACE THE ANTENNA AT ITS EXPENSE WITHIN THIRTY DAYS OF THE DATE THE ANTENNA IS RETURNED (AT PURCHASER'S EXPENSE) TO CUSHCRAFT OR ONE OF ITS AUTHORIZED REPRESENTATIVES. THIS WARRANTY IS IN LIEU OF ALL OTHER EXPRESSED WARRANTIES, ANY IMPLIED WARRANTY IS LIMITED IN DURATION TO ONE YEAR. CUSHCRAFT CORPORATION SHALL NOT BE LIABLE FOR ANY INCIDENTAL OR CONSEQUENTIAL DAMAGES WHICH MAY RESULT FROM A DEFECT. SOME STATES DO NOT ALLOW LIMITATIONS ON HOW LONG AN IMPLIED WARRANTY LASTS OR EXCLUSIONS OR LIMITATIONS OF INCIDENTAL OR CONSEQUENTIAL DAMAGES, SO THE ABOVE LIMITATION AND EXCLUSION MAY NOT APPLY TO YOU. THIS WARRANTY GIVES YOU SPECIFIC LEGAL RIGHTS, AND YOU MAY ALSO HAVE OTHER RIGHTS WHICH VARY FROM STATE TO STATE. THIS WARRANTY DOES NOT EXTEND TO ANY PRODUCTS WHICH HAVE BEEN SUBJECT TO MISUSE, NEGLIGENCE, ACCIDENT OR IMPROPER INSTALLATION, ANY REPAIRS OR ALTERATIONS OUTSIDE OF THE CUSHCRAFT CORPORATION FACTORY WILL NULLIFY THIS WARRANTY.

SPECIFICATIONS SUBJECT TO CHANGE WITHOUT NOTICE

**WARRANTY AND LIABILITY**

Cushcraft Corporation shall not be liable for any incidental or consequential damages which may result from a defect, or use, improper or otherwise or installation, improper or otherwise.  
Please contact your vendor for technical support and warranty service.



**48 Perimeter Road  
Manchester, NH 03103  
603-627-7877  
FAX 603-627-1764**

SPECIFICATIONS SUBJECT TO CHANGE WITHOUT NOTICE

**TA5FA**