

ASSEMBLY AND INSTALLATION INSTRUCTIONS

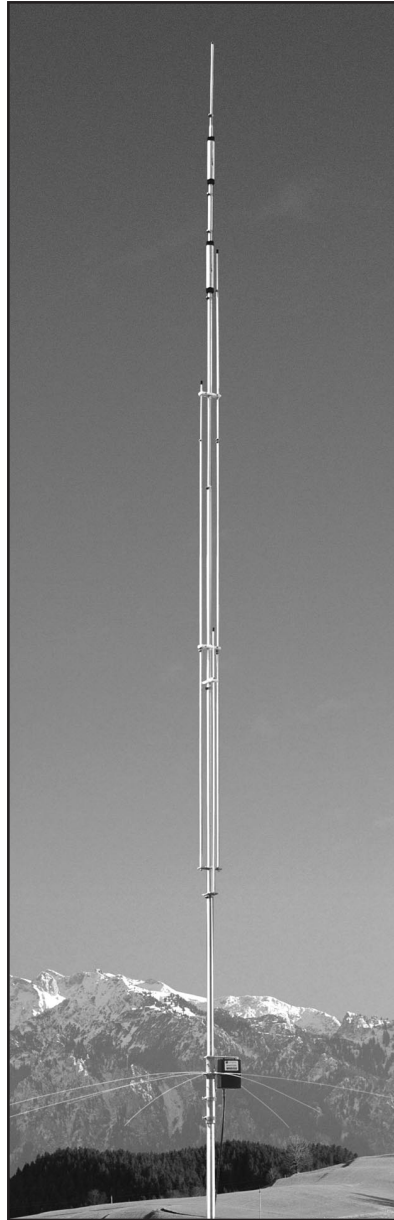

R6000

6, 10, 12, 15, 17, 20 Meters



CUSHCRAFT
COMMUNICATIONS ANTENNAS

951472 (2/99)

TA5FA

WARNING

THIS ANTENNA IS AN ELECTRICAL CONDUCTOR. CONTACT WITH POWER LINES CAN RESULT IN DEATH, OR SERIOUS INJURY. DO NOT INSTALL THIS ANTENNA WHERE THERE IS ANY POSSIBILITY OF CONTACT WITH HIGH VOLTAGE OR ARC-OVER FROM POWER CABLES OR SERVICE DROPS TO BUILDINGS. THE ANTENNA, SUPPORTING MAST AND/OR TOWER MUST NOT BE CLOSE TO ANY POWER LINES DURING INSTALLATION, REMOVAL OR IN THE EVENT PART OF THE SYSTEM SHOULD ACCIDENTALLY FALL. FOLLOW THE GUIDELINES FOR ANTENNA INSTALLATIONS RECOMMENDED BY THE U.S. CONSUMER PRODUCT SAFETY COMMISSION AND LISTED IN THE ENCLOSED PAMPHLET.

Your Cushcraft R6000 vertical antenna is designed and manufactured to give trouble free service. This antenna will perform as specified if the instructions and suggestions in this manual are followed and care is used in the assembly and installation. When checking the components received in your antenna package use the parts listed beside each diagram. There is a master parts list on page 2. If you are unable to locate any tube or component, check the inside of all tubing. **IMPORTANT:** Save the weight label from the outside of the carton. Each antenna is weighed at the factory to verify the parts count. If you claim a missing part, you will be asked for the weight verification label.

If you have technical questions and have access to the World Wide Web you can visit Cushcraft's **TECHEXPRESS** support service (<http://www.cushcraft.com>). The site enables the user to place parts orders, ask technical questions, locate part numbers, initiate warranty inquires and review *Frequently Asked Questions*. Our technical support staff can be reached by phone at (603) 627-7877 (8 AM to 5 PM Eastern time or voice mail after hours), faxed at (603) 627-1764 or can be e-mailed at techsup@cushcraft.com.

PLANNING

Plan your installation carefully. If you use volunteer helpers be sure that they are qualified to assist you. Make certain that everyone involved understands that you are the boss and that they must follow your instructions. If you have any doubts at all, employ a professional antenna installation company to install your antenna.

LOCATION

Although the R6000 will operate in almost any location, it will perform best if it is mounted vertically and located in the clear away from surrounding objects such as buildings, trees, power lines, towers, guy wires, antennas and metallic objects. The R6000 should not be attached to a ground radial system. Failure to heed these points will possibly degrade performance, detune the antenna and increase VSWR.

EXTREME CARE MUST BE USED FOR YOUR SAFETY. YOU MUST INSURE THAT WHILE THE R6000 IS IN OPERATION NEITHER PEOPLE OR PETS CAN COME IN CONTACT WITH ANY PORTION OF YOUR ANTENNA INCLUDING THE COUNTERPOISE RODS. DEADLY VOLTAGES AND CURRENTS MAY EXIST. ALSO, SINCE THE EFFECTS OF EXPOSURE TO RF ARE NOT FULLY UNDERSTOOD, LONG TERM EXPOSURE TO INTENSE RF FIELDS IS NOT RECOMMENDED. THERE ARE SEVEN WARNING STICKERS WHICH MUST BE ATTACHED TO THE ENDS OF THE COUNTERPOISE RODS AS SHOWN IN FIGURE E.

MOUNTING

Your mast should be rigid and pointing straight up. Always use a mast at least 1-1/2 inches (3.8 cm) but not larger than 1-3/4 inches (4.4 cm) in diameter. If you guy the mast, use non-conducting guy wires.

SYSTEM GROUNDING

Direct grounding of the antenna mast is very important. This serves as protection from lightning strikes and static buildup, and from high voltages which may be present in the equipment attached to the antenna. A good electrical connection should be made to one or more ground rods directly at the base of the antenna or mast using a least #10 AWG ground wire and non-corrosive hardware. For details and safety standards, consult the National Electrical Code. You should also use a coaxial lightning arrester. Cushcraft offers several different models, such as the LAC-4 series.

ASSEMBLY

Assemble your R6000 by following steps 1 through 5. After assembling the antenna, verify all dimensions in Chart A for accuracy. Then return to the adjustment section below for final tuning.

ADJUSTMENT

The dimensions in Chart A normally allow proper operation on all the bands. However, some variations may occur from one location to another. Adjustments must be made from the bottom of the antenna to the top. Adjusting the antenna from top to bottom will not work. This is because the settings at the top are severely affected by the adjustments at the bottom.

We suggest measuring the VSWR of your antenna by using the SWR meter in your transceiver. If your transceiver does not have one, use a good quality VSWR bridge for this application. Begin with 6 meters since this is at the bottom of the antenna. Set your transceiver at your favorite frequency on 6 meters. Key the rig and check your VSWR. The R6000 is extremely broadbanded on 6 meters and seldom needs adjustment. If the VSWR is low enough (below 1.5:1) then move on to the 10 meter band. If the 10 meter VSWR is not low enough, adjust the antenna as follows: Check several frequencies on 10 meters to find the frequency of lowest VSWR. If the frequency of lowest VSWR is above your favorite frequency, lengthen dimension D (figure F) by 1 inch (2.5 cm). This should lower the frequency of lowest VSWR by 50 to 100 KHz. If the frequency of lowest VSWR is below your desired frequency, shorten dimension D (figure F) by 1 inch (2.5 cm). Check your desired 10 meter operating frequency again to see if the VSWR is less than 1.5:1. Repeat this procedure until the VSWR at your desired frequency is low enough.

Continue this procedure by selecting your desired frequency on 12 meters and checking the VSWR there. Dimension E (figure F) should be used to adjust the VSWR on 15 meters. *Remember to shorten this dimension to raise the frequency or lengthen it to lower the frequency.*

The balance of the antenna should be adjusted in a like manner. The dimensions and the bands that they effect are shown in figure F. On 10 through 20 meters 1 inch (2.5 cm) of change in length will change the operating frequency by 50 to 100 KHz. When the antenna is completely adjusted, check all fasteners to be sure they are tight. Improving VSWR's that are less than 2:1 will not noticeably improve station performance.

INSTALLATION

Following the guidelines in the location and adjustment sections above, place the antenna on its mast in its final operating location. If you plan to install the antenna in a salty or corrosive environment, you may want to consider coating it with a clear marine varnish or equivalent *after final assembly and adjustment has been completed*. Now connect your transceiver. If you have any difficulties, reread the information above and the helpful hints below.

INSTALLATION RECOMMENDATIONS AND OPERATING TIPS

These Installation Recommendations and Operating Tips are offered to help you enjoy the use of your antenna to the fullest. In our estimation, your system will work "optimally", while achieving the longest service life if they are followed.

- Horizontally space your antenna sixty-six (66) feet from any surrounding metal.
- When considering height above ground, achieving "line of sight" is most desirable for optimal performance. It is recommended that you achieve line of sight and be at least ten (10) feet above ground.
- Do not use vinyl tape on SO-239 or PL-259 connectors.
- Use Phillystran for top guying.
- Use liquid soap on the threads of Nylock washers to prevent friction and galling of stainless steel parts.
- Try to locate your R6000 as far away from TV antennas and their feedlines as possible. This will help to avoid overloading your television with RF.
- If you check the resistance across the coax connector on your R6000 you will find a DC short. This is normal. It does not mean that the RF path is short circuited. It is approximately 50 Ohms at your operating frequencies.
- High VSWR is sometimes caused by poor contact between the matching network and the counterpoise rods. Make sure that corrosion has not formed on the jumper strap terminals. Check to insure the hardware is tight.
- If your R6000 is very close to your shack you may experience RF on the feedline. Try lengthening your feedline several feet, placing an RF ferrite bead on the coax, winding the feedline on a toroid or winding the coax in a 10 turn coil 8 inches (20 cm) in diameter.
- Weather sealing the matching network is not necessary. We have provided a large hole near the coax connector to allow air to circulate through the box and to keep it dry. Keep this hole clear to avoid difficulties caused by humidity and condensation.
- Long periods (2 minutes or longer) of key down operation, such as RTTY, at high power (over 1500 Watts) may damage your R6000.
- Anti-oxidation compound can be used on aluminum tubing connections, but NOT on electrical/RF connections on the Matching Network.
- For improved waterproofing, you may apply an RTV[®] type sealant on the top plastic caps of CS1 and CS2.
- When measuring SWR do not rely only on readings from "Antenna Analyzers". They are subject to incorrect readings due to nearby RF fields. This is due to a lack of input filtering. Verify readings with your transceiver and an SWR bridge.

PART#	QTY	DESCRIPTION	PART#	QTY	DESCRIPTION
010079	8	#8-32 x 1/2" (1.3cm) SS Machine Screw	204813	2	Plastic Clamp
010082	4	1/4-20 x 1" (2.5cm) SS Hex Head Bolt	204814	1	Aluminum Clamp Assembly
010084	4	1/4" SS Lock Washer	204923	1	Plastic Clamp
010085	4	1/4-20 SS Nut	240116	1	Silicone Package
010232	3	#8-32 x 2 1/2" (6.3cm) SS Machine Screw	290326	7	Warning Label
014387	28	#8-32 SS Lock Nut	902428	1	Jumper Strap
014388	1	10-24 SS Lock Nut	902832	7	49" (124.5 cm) SS Radial Rod
014764	14	#8-32 x 2 1/4" (5.7cm) SS Machine Screw	MN6000	1	Matching Network
030407	9	5/8" (1.6cm) SS Worm Clamp	BA	1	Base Assembly
030409	1	15/16" (2.4cm) SS Worm Clamp	BB	1	1 1/4" x 48" (3.2cm x 122cm) aluminum tube slotted one end
030411	4	1 1/4" (3.2cm) SS Worm Clamp	BC	1	1 1/8" x 48" (2.8cm x 122cm) aluminum tube slotted one end
030412	2	1 1/2" (3.8cm) SS Worm Clamp	BD	1	1" x 48" (2.5cm x 122cm) aluminum tube slotted one end
050053	1	1/2" (1.3cm) Plastic Cap	BE	1	1" x 12" (2.5cm x 30.5 cm) aluminum tube slotted both ends
050077	3	3/8" (1.0 cm) Plastic Cap	BF	1	1/2" x 21" (1.3cm x 53.3cm) aluminum tube
050115	1	Connector Boot	BG	3	1/2" x 48" (1.3cm x 122cm) aluminum tube slotted one end
194173	4	Radial Ring Bracket	BH	2	1/2" x 48" (1.3cm x 122cm) aluminum tube slotted both ends
194174	2	Radial Ring	BJ	1	1/2" x 36" (1.3cm x 122cm) aluminum tube slotted 1 end
194748	1	Upper Matching Network Bracket	BK	2	3/8" x 18" (1.0cm x 45.7cm) aluminum tube
203110	2	Mast Mount Clamp	BL	3	3/8" x 6" (1.0cm x 15.2cm) aluminum tube
204727	2	Plastic Clamp	BM	1	3/8" x 12" (.9 x 30.5 cm) aluminum tube
204728	2	Plastic Clamp	CS1	1	12 Meter Trap
204729	1	Aluminum Clamp Assembly	CS2	1	17 Meter Trap

#1 - ASSEMBLE RADIAL RINGS

FIGURE A

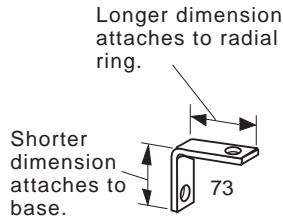

FIGURE B

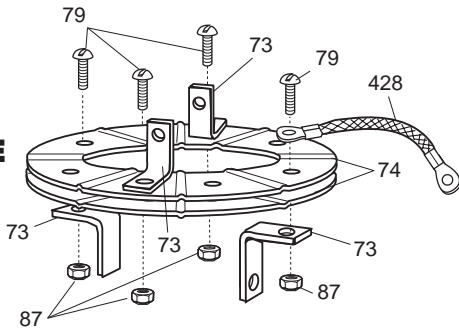

FIGURE C

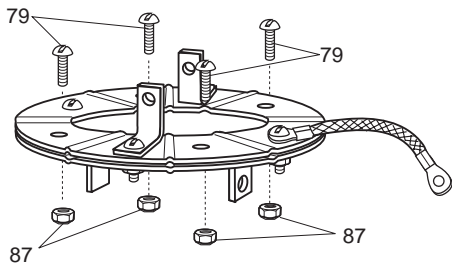
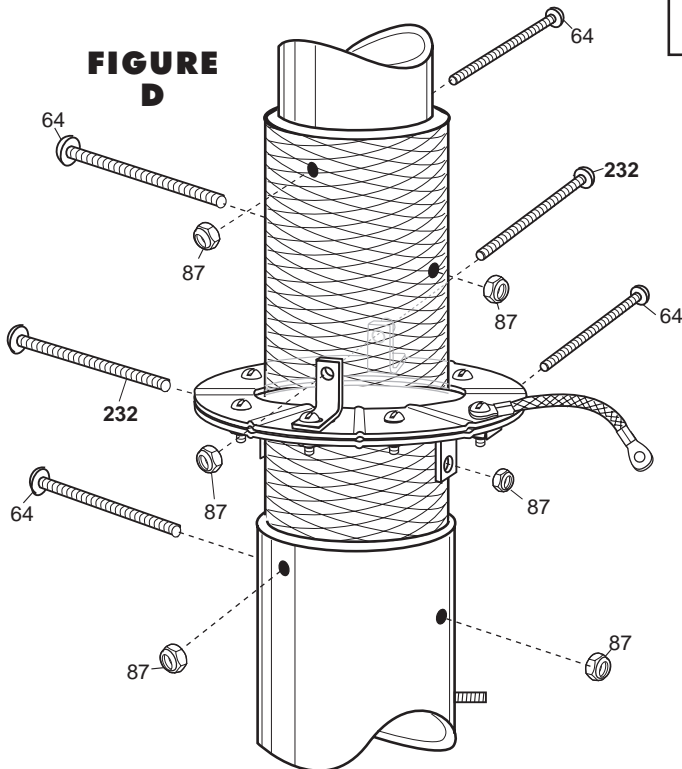

FIGURE D



Figures A through D show the steps for radial ring assembly. Refer to the Radial Ring Subassembly Parts List for the parts required in this step. Slide the two radial rings (74) onto the base assembly (BA). Note the orientation of the ring slots. Attach the rings to the base using the radial ring brackets (73), 2 1/2" screws (232), 1/2" screws (79) and lock nuts (87). Leave hardware loose until Step #2. Note the proper orientation of the radial ring brackets in Figure A. Install jumper strap (428) as shown in Figure D.

NOTE: Do not accidentally use the #10-24 nut in this step.

Insert four 2 1/4" screws (64) into the base assembly (BA) as shown in Figure D. Secure with nuts (87).

KEY	P/N	DISPLAY	DESC	SIZE	
BA			BASE ASSEMBLY		1
64	014764		SS MACHINE SCREW	#8-32 x 2-1/4" (5.7 cm)	4
73	194173		RADIAL RING BRACKET		4
74	194174		RADIAL RING		2
79	010079		SS MACHINE SCREW	8-32 x 1/2" (1.3 cm)	8
87	014387		SS LOCK NUT	8-32	14
232	010232		SS MACHINE SCREW	8-32 x 2-1/2" (6.35 cm)	2
428	902428		STRAP		1





#2 - ATTACH MATCHING NETWORK AND RADIALS

Slide upper matching network bracket (48) onto base section (BA). Place it tight against the fiberglass insulator. Insert one 2 1/2" screw (232) into bracket (48) and attach nut (87) as shown in Figure E. Slide Matching Network (MN) screws into holes on upper matching network bracket (48). Position bottom MN bracket over captive screw in base section (BA) and secure with #10 nut (88). Secure MN to upper MN bracket (48) with two nuts (87). Tighten screw in upper MN bracket (48).

The radial rods may be inserted into the base section at any time in the assembly process.

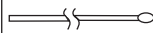
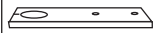
One at a time, place the stainless radial rods (32) into the slots in the radial rings. Tighten the corresponding ring screws as you work your way around the rings. The radial rings do not have to touch each other to secure the radial rods properly. Do not overtighten the screws. When all rods are secure, tighten all hardware on the base section. Attach jumper strap (428) to MN screw with nut (87).

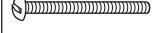
Attach warning labels (326) as shown.

KEY	P/N	DISPLAY	DESC	SIZE	
32	902832		SS RADIAL	49" (124.5 cm)	7
48	194748		MN6000 BRACKET		1
87	014387		SS LOCK NUT	#8-32	4
88	014388		SS LOCK NUT	10-24	1
232	010232		SS MACHINE SCREW	#8-32 x 2-1/2" (6.35 cm)	1
326	290326		WARNING LABEL		7
MN	MN6000		MATCHING NETWORK		1

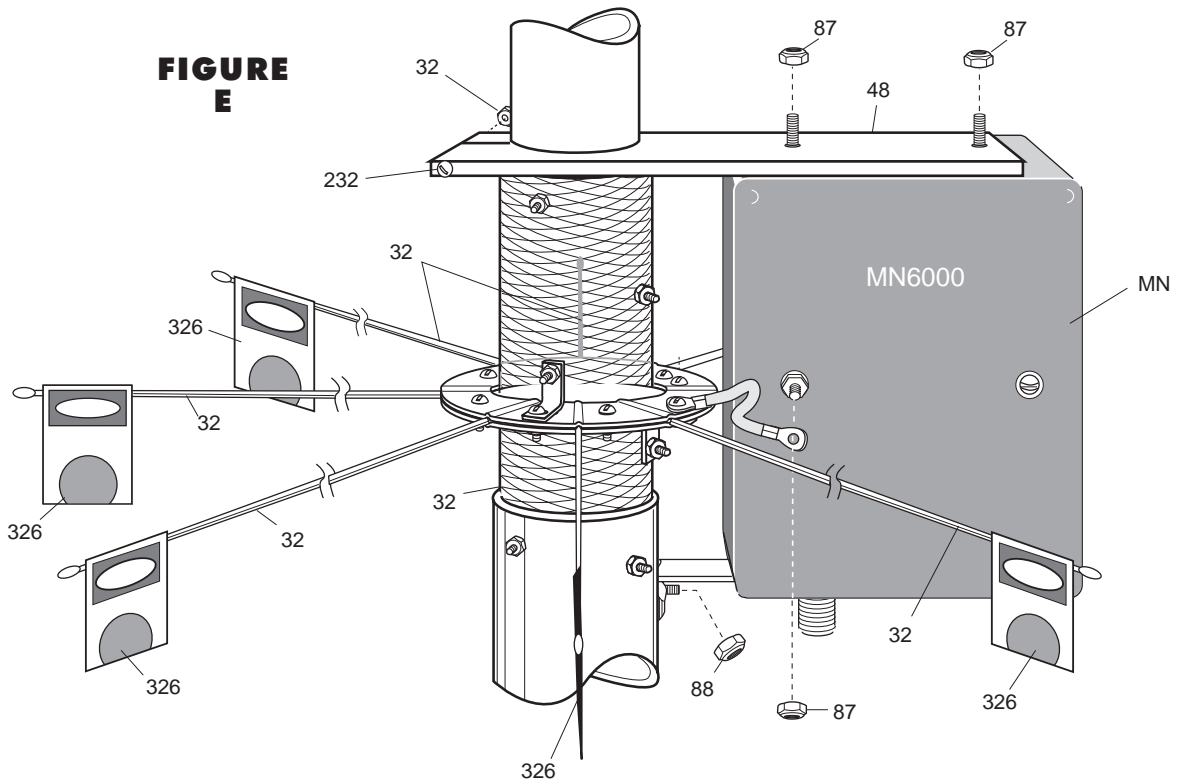

#3 - ASSEMBLE RADIATOR

Place worm clamp (413) over top end of base assembly (BA). Slide non-slotted end of section BB into BA section 3 inches (7.6 cm) and secure worm clamp. Leave the aluminum clamp assemblies 814 and 29 screwed together. Slide (814) onto BB (Figure F3) and loosely secure with second screw (64) and nut (87). Now slide second clamp assembly (29) onto BB and secure loosely with screw (64) and nut (87).

Place worm clamp (412) over top end of section BB. Slide non-slotted end of section BC into BB section 3 inches (7.6 cm) and secure worm clamp. Place worm clamp (411) over top end of section BC. Slide non-slotted end of section BD into BC section 2 inches (5.1 cm) and secure worm clamp. Place worm clamp (411) over top end of section BD.

See Figure F for proper trap placement. Note that trap arrows point DOWN towards the R6000 base. Also note that bottom trap cap has a drain hole for water. There is no drain hole in the top cap. Hold trap CS1 with arrow pointing down and slide bottom tube into section BD 2 inches (5.1 cm). Secure worm clamp. Place a worm clamp (411) on each end of section BE. Slide BE tube over CS1 top tube 2 inches (5.1 cm) and secure worm clamp. Hold trap CS2 with arrow pointing down and slide bottom tube into section BE 2 inches (5.1 cm) and secure worm clamp. Place worm clamp (409) on top tube of trap CS2. Slide section BF into trap CS2. Refer to Chart A for Dimension "C". Adjust length of section BF for Dimension "C" and secure worm clamp. Place plastic cap (53) on end of section BF.

Place clamp (29) 5-1/2" (14.0 cm) above the top end of the base assembly (BA). Place a BG section in both of the 1/2" (1.3 cm) holes. Let the BG tube protrude 1/2" (1.3 cm) below the clamp (29) and tighten the clamp screws. Insert a BL tube 3 inches (7.6 cm) into the top of each BG section. Secure with a worm clamp (407). Slide a BH tube onto each BL tube until the BH tube butts against the BG tube. Secure with a worm clamp (407). Position the lower radiator brackets (28) around the BC and BH sections at the position shown in Figures F and F2. Align the brackets with the clamp (29) below. Insert 2 screws (64) into brackets and secure with nuts (87). DO NOT OVERTIGHTEN THE BRACKET SCREWS. The brackets are for proper spacing of the radiator section and are not required to physically support the aluminum tube. Slide a BK tube into one of the BH tubes 5 inches (12.7 cm) and secure with worm clamp (407). Insert a BL tube 3 inches (7.6 cm) into the top of the second BH tube and secure with worm clamp (407). Slide a BJ tube over the BL tube until BJ tube butts against the BH tube. Secure with worm clamp (407). Insert BK tube into the BJ tube 9 inches (22.9 cm) and secure with worm clamp (407). Place a plastic cap (77) over the top of each BK tube. Position the upper radiator brackets (27) around the BD, BJ, and BK sections at the position shown in Figure F. Position the 15m radiator bracket (923) around the BD and BJ sections. Align the brackets with the clamp (29) and brackets (28) below. Insert 2 screws (64) into brackets and secure with nuts (87). DO NOT OVERTIGHTEN THE BRACKET SCREWS. The brackets are for proper spacing of the radiator section and are not required to physically support the aluminum tube.

Secure the 814 bracket assembly flush against the top of BA with BG tube in place 1/2" (1.3 cm) below the brackets (Figure F3). Attach brackets (813) to tubes BC and BG (Figure F2) using screws (64) and nuts (87). Put worm clamp (407) over top of BG tube, insert tube BM and secure. Set Dimension F using Chart B.

Verify all radiator dimensions are within 1/4" (0.6 cm) of the values in Chart A. Set dimension C for the desired 20 meter frequency in Chart A.

FIGURE F1

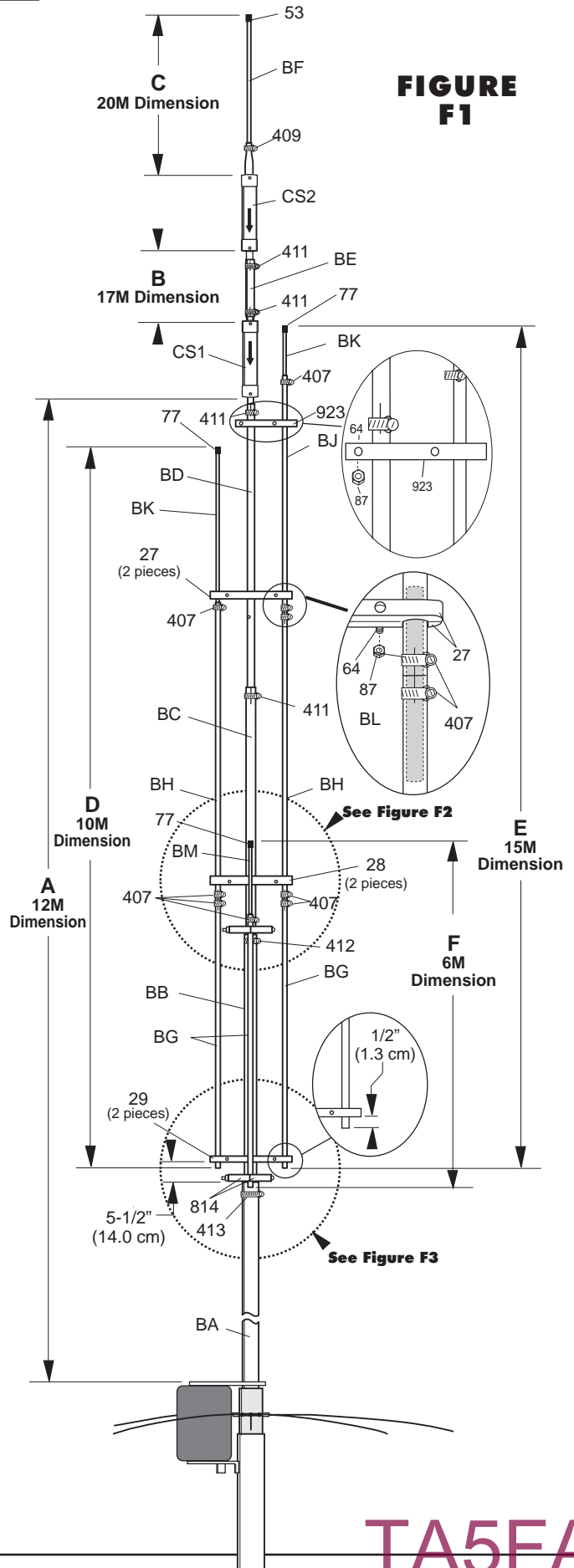

Chart A

Dimension	Inches	CM
A	170	432
B	14	35.6
C (CW)	24	61
C (Center)	23-1/2	60
C (SSB)	23	58.5
D	109	277
E	141	358

**Chart B
Dimension F**

Freq.	Inches	CM
50.15	58	147.3
51	57	144.8
51.7	56	142.2
52.3	55.5	141
52.5	55	139.7
53.5	54	137.2

TA5FA

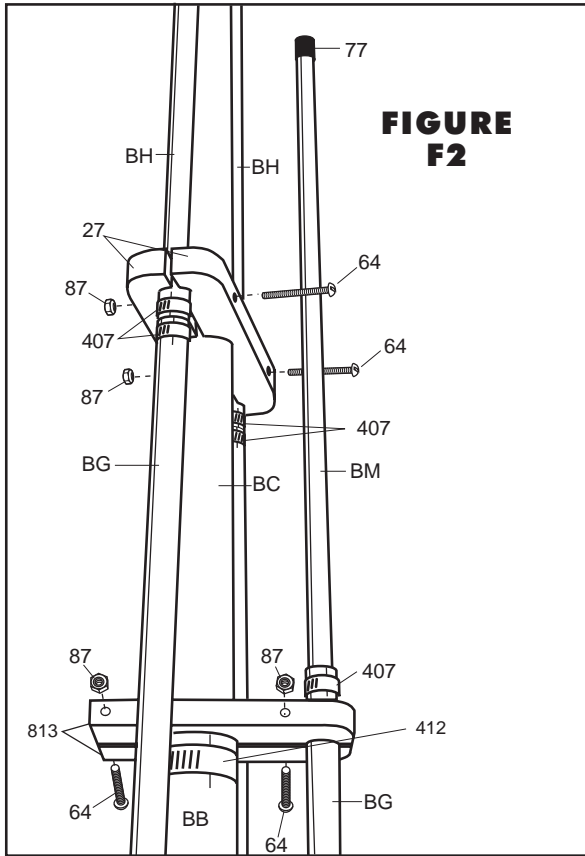

FIGURE F2

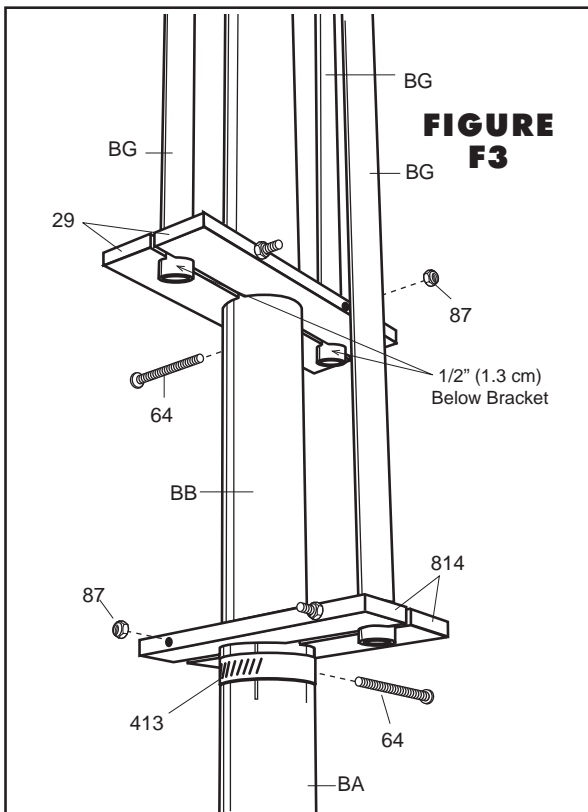

FIGURE F3

KEY	P/N	DISPLAY	DESC	SIZE	
27	204727		UPPER PLASTIC CLAMP		2
28	204728		LOWER PLASTIC CLAMP		2
29	204729		ALU CLAMP ASSEMBLY		1
53	050053		PLASTIC CAP	1/2" (1.3 cm)	1
64	014764		SS MACHINE SCREW	#8-32 x 2-1/4" (5.7 cm)	10
77	050077		PLASTIC CAP	3/8" (1.0 cm)	3
87	014387		SS LOCK NUT	#8-32	12
407	030407		SS WORM CLAMP	5/8" (1.6 cm)	9
409	030409		SS WORM CLAMP	15/16" (2.4 cm)	1
411	030411		SS WORM CLAMP	1-1/4" (3.2)	4
412	030412		SS WORM CLAMP	1-1/2" (3.8 cm)	2
813	204813		PLASTIC CLAMP		2
814	204814		ALU CLAMP ASSEMBLY		1
923	204923		PLASTIC CLAMP		2
BA			BASE ASSEMBLY		1
BB			ALUMINUM TUBE	1-1/4" x 48" (3.2 x 121.9 cm)	1
BC			ALUMINUM TUBE	1-1/8" x 48" (2.8 x 122 cm)	1
BD			ALUMINUM TUBE	1" x 48" (2.5 x 122)	1
BE			ALUMINUM TUBE	1" x 10" (2.5 x 25.4 cm)	1
BF			ALUMINUM TUBE	1/2" x 21" (1.3 x 53.3 cm)	1
BG			ALUMINUM TUBE	1/2" x 48" (1.3 x 122)	3
BH			ALUMINUM TUBE	1/2" x 48" (1.3 x 122 cm)	2
BJ			ALUMINUM TUBE	1/2" x 36" (1.3 x 122)	1
BK			ALUMINUM TUBE	3/8" x 18" (1.0 x 45.7)	2
BL			ALUMINUM TUBE	3/8" x 6" (1.0 x 15.2)	3
BM			ALUMINUM TUBE	3/8" x 12" (1.0 x 30.5 cm)	1
CS1			12 METER TRAP		1
CS2			17 METER TRAP		1

#4 - BASE CLAMP SUBASSEMBLY

Refer to the Base to Mast Subassembly Parts List for the parts required in this step. Slide both mast mount rings (110) around the bottom of the base assembly. Attach antenna base to your mast as shown in Figure G. Insert screws (82), nuts (85), and washers (84) into rings and tighten hardware against mast. Do not over tighten screws.







KEY	P/N	DISPLAY	DESC	SIZE	
82	010082		SS HEX HEAD BOLT	1/4-20 x 1" (2.5 cm)	4
84	010084		SS LOCK WASHER	1/4" (.6 cm)	4
85	010085		SS NUT	1/4-20	4
110	203110		MAST MOUNT CLAMP		2

FIGURE G

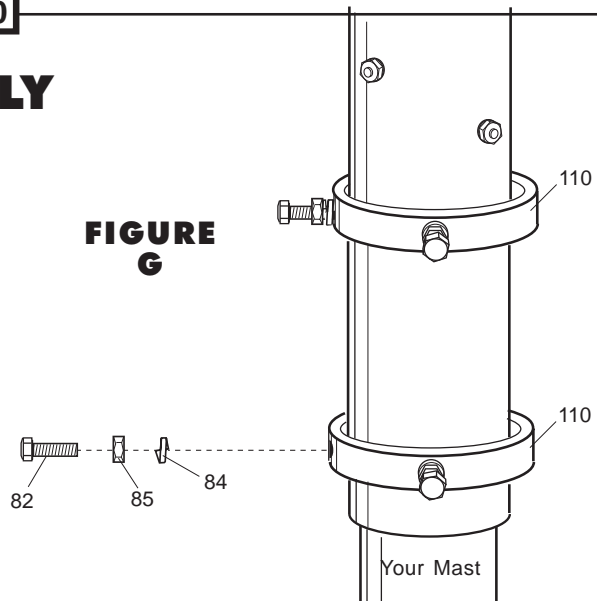

#5 - FEEDLINE

The R6000 is designed for use with 50 Ohm coaxial cable terminated with a PL-259 connector. The shortest length of cable will have the least loss. A connector boot is included for use with your new antenna (figure H). Slide the boot over the cable before attaching your PL-259. Coat only the outside connector threads and shell with silicone grease. **Do not coat the center pin or receptacle.** After the PL-259 is firmly screwed onto the antenna connector, slide the vinyl boot over the connector and against the connector bracket for a good weather-tight connection. After the antenna is on the mast, tape the feedline to the mast.

KEY	PART#	DISPLAY	DESCRIPTION	SIZE	QTY
115	050115		CONNECTOR BOOT		1
116	240116		SILICONE PACKAGE		1

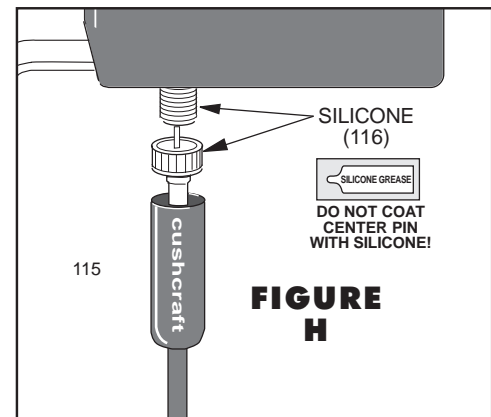

FIGURE H

SPECIFICATIONS

Frequency, meters	6, 10, 12, 15, 17, 20
Gain, dBi	3
VSWR minimum	1.2:1 typical
2:1 bandwidth, KHz	6m >1300 10m >1700 12m >100 15m >450 17m >100 20m 300
Power, Watts output	1500
Radiation angle, deg.	16
Horizontal rad, deg	360
Height, ft (m)	19 (5.8)
Mast size range, in (cm)	1.5 -1.75 (3.8-4.4)
Wind load, ft ² (m ²)	1.5 (.14)
Wind Survival, mph (kph)	80 (128)
Weight, lb (kg)	12.5 (5.6)

LIMITED WARRANTY

Cushcraft Corporation, P.O. Box 4680, Manchester, New Hampshire 03108, warrants to the original purchaser for one year from date of purchase that each Cushcraft antenna is free of defects in material or workmanship. If, in the judgement of Cushcraft, any such antenna is defective, then Cushcraft Corporation will, at its option, repair or replace the antenna at its expense within thirty days of the date the antenna is returned (at purchasers expense) to Cushcraft or one of its authorized representatives. This warranty is in lieu of all other expressed warranties, any implied warranty is limited in duration to one year. Cushcraft Corporation shall not be liable for any incidental or consequential damages which may result from a defect. Some states do not allow limitations on how long an implied warranty lasts or exclusions or limitations of incidental or consequential damages, so the above limitation and exclusion may not apply to you. This warranty gives you specific legal rights, and you may also have other rights which vary from state to state. This warranty does not extend to any products which have been subject the misuse, neglect, accident or improper installation. Any repairs or alterations outside of the Cushcraft factory will nullify this warranty.

SPECIFICATIONS SUBJECT TO CHANGE WITHOUT NOTICE



48 PERIMETER ROAD, MANCHESTER, NH 03108 USA
TELEPHONE: 603-627-7877 • FAX: 603-627-1764 • E-mail: techsup@cushcraft.com

TA5FA