

**ASSEMBLY AND INSTALLATION
INSTRUCTIONS**



ROO

6,10, 12, 15, 17, 20, 30, 40, Meters



TA5FA
951489 (9/01)

WARNING

THIS ANTENNA IS AN ELECTRICAL CONDUCTOR. CONTACT WITH POWER LINES CAN RESULT IN DEATH, OR SERIOUS INJURY. DO NOT INSTALL THIS ANTENNA WHERE THERE IS ANY POSSIBILITY OF CONTACT WITH HIGH VOLTAGE OR ARC-OVER FROM POWER CABLES OR SERVICE DROPS TO BUILDINGS. THE ANTENNA, SUPPORTING MAST AND/OR TOWER MUST NOT BE CLOSE TO ANY POWER LINES DURING INSTALLATION, REMOVAL OR IN THE EVENT PART OF THE SYSTEM SHOULD ACCIDENTALLY FALL. FOLLOW THE GUIDELINES FOR ANTENNA INSTALLATIONS RECOMMENDED BY THE U.S. CONSUMER PRODUCT SAFETY COMMISSION AND LISTED IN THE ENCLOSED PAMPHLET.

Your Cushcraft R8 vertical antenna is designed and manufactured to give trouble free service. This antenna will perform as specified if the instructions and suggestions in this manual are followed and care is used in the assembly and installation. When checking the components received in your antenna package use the parts listed beside each diagram. There is a master parts list on page 2. If you are unable to locate any tube or component, check the inside of all tubing. **IMPORTANT:** Save the weight label from the outside of the carton. Each antenna is weighed at the factory to verify the parts count. If you claim a missing part, you will be asked for the weight verification label.

PLANNING

Plan your installation carefully. If you use volunteer helpers be sure that they are qualified to assist you. Make certain that everyone involved understands that you are the boss and that they must follow your instructions. If you have any doubts at all, employ a professional antenna installation company to install your antenna.

LOCATION

Although the R8 will operate in almost any location, it will perform best if it is mounted vertically and located in the clear away from surrounding objects such as buildings, trees, power lines, towers, guy wires, antennas and metallic objects.

EXTREME CARE MUST BE USED FOR YOUR SAFETY. YOU MUST INSURE THAT WHILE THE R8 IS IN OPERATION NEITHER PEOPLE NOR PETS CAN COME IN CONTACT WITH ANY PORTION OF YOUR ANTENNA INCLUDING THE COUNTERPOISE RODS. DEADLY VOLTAGES AND CURRENTS MAY EXIST. ALSO, SINCE THE EFFECTS OF EXPOSURE TO RF ARE NOT FULLY UNDERSTOOD, LONG TERM EXPOSURE TO INTENSE RF FIELDS IS NOT RECOMMENDED. THERE ARE SEVEN WARNING STICKERS WHICH MUST BE ATTACHED TO THE ENDS OF THE COUNTERPOISE RODS AS SHOWN IN FIGURE E.

MOUNTING

Your mast should be rigid and pointing straight up. Always use a mast at least 1-3/4 inches (4.4 cm) but not larger than 2-1/8 inches (5.4 cm) in diameter. If you guy the mast, use nonconducting guy wires.

SYSTEM GROUNDING

Direct grounding of the antenna mast is very important. This serves as protection from lightning strikes and static buildup, and from high voltages which may be present in the equipment attached to the antenna. A good electrical connection should be made to one or more ground rods directly at the base of the antenna or mast using a least #10 AWG ground wire and noncorrosive hardware. For details and safety standards, consult the National Electrical Code. You should also use a coaxial lightning arrester. Cushcraft offers several different models, such as the LAC-1, LAC-2 or the LAC-4 series.

ASSEMBLY

Assemble your R8 by following steps 1 through 12. After assembling the antenna, verify all dimensions for accuracy.

TA5FA

MASTER PARTS LIST

KEY	PART#	DESCRIPTION	QTY
BA		Base assembly	1
BB		R8 Tube BB 1-1/4" x 72"(3.17 x 182.9cm)	1
BC		R8 Tube BC 1-1/8" x 72"(2.9 x 182.9cm)	1
BD		R8 Tube BD 1" x 36" (2.5 x 91cm)	1
BE		R8 Tube BE 7/8" x 16" (2.3 x 40.5cm)	1
BF		R8 Tube BF 7/8" Swedged x 10-3/4" (2.3 x 27.3cm)	1
BG		R8 Tube BG 1/2" x 24" (1.2 x 61cm)	1
BH		R8 Tube BH 3/8" x 24" (0.9 x 61cm)	1
SA		R8 Stub SA 3/8" x 52" (0.9 x 132cm)	1
SB		R8 Stub SB 1/4" x 6" (0.6 x 15cm)	6
SC		R8 Stub SC 3/8" x 48" (0.9 x 121.9cm)	1
SD		R8 Stub SD 1/4" x 48" (0.6 x 121.9cm)	1
SE		R8 Stub SE 1/4" x 12" (0.6 x 30cm)	1
SF		R8 Stub SF 3/8" x 72" (0.9 x 182.8cm)	2
SG		R8 Stub SG 3/8" x 43-1/2" (0.9 x 110.5cm)	1
SH		R8 Stub SH 3/8" x 68" (0.9 x 173cm)	1
BT1		BT1 Trap 17 / 20 Meter	1
BT2		BT2 Trap 30 Meter	1
MN8		R8 Matching Network	1
XHR32		32" X-Hat Rod	2
XHR40		40" X-Hat Rod	2
09	010009	# 8-32 x 5/8" SS RH MS	12
11	010011	# 8-32 SS Hex Nut	18
26	190026	Aluminum Bracket	4
28	190028	Aluminum Half Washer	4
32	902832	49" Whip & Tip Assembly	7
63	170063	Extruded Aluminum V-Block	4
64	014764	# 8-32 x 2-1/4" SS Machine Screw	2
73	194173	Radial Ring Bracket	4
74	194174	Radial Ring	2
76	054276	3/8" x 7/8" Black plastic Cap	1
79	010079	# 8-32" x 1/2" SS RH MS	4
87	014387	# 8-32 x SS/Nylon Hex Nut	21
96	010096	# 8-32 x 3/8" SS RH MS	4
99	205099	Aluminum Stub Clamp	2
105	055105	1/4" Black Plastic Cap	4
115	050115	Connector Boot	1
116	240116	Silicone Package	1
120	010120	# 8-32 x 2" SS RH MS	1
160	190160	Matching Network Bracket	1
220	010220	# 10-24 SS Hex Nut	1
231	010231	# 8-32 x 1-3/4" SS RH MS	7
232	010232	# 8-32 x 2-1/2" SS RH MS	6
233	010233	# 10 SS Split Lock Washer	1
326	290326	Danger Label	8
389	014389	5/16-18 SS/Nylon Hex Nut	8
404	010404	U-Bolt SS 5/16-18 3-1/4 (2-7/16 C-C)	2
405	010405	U-bolt SS 5/16-18 4-1/2 (2-7/16 C-C)	2
407	030407	Worm Clamp SS 7/32" - 5/8"	10
409	030409	Worm Clamp SS 3/8" - 7/8"	2
410	030410	Worm Clamp SS 7/16" - 1"	3
411	030411	Worm Clamp SS 9/16" - 1-1/4"	2
412	030412	Worm Clamp SS 11/16" - 1-1/2"	1
413	030413	Worm Clamp SS 3/4" - 1-3/4"	1
428	902428	Ground Strap	1
657	194657	Aluminum L Bracket	6
940	360940	# 8 Aluminum Flat Washer	12
941	011941	# 8 SS Split Lock Washer	18
4079	194079	Aluminum Mounting Plate	1
5072	205072	4-Hole Insulator	1
5096	205096	3-Hole Insulator	1
5097	205097	2-Hole Insulator	1

#1 - ASSEMBLE RADIAL RINGS

Figures A through D show the steps for radial ring assembly. Refer to the parts table below for the parts required in this step. Slide the two radial rings (74) onto the base assembly (BA). Note the orientation of the ring slots. Attach the rings to the base using the radial ring brackets (73), 2 1/2" screws (232), 1/2" screws (79) and lock nuts (87). Leave hardware loose until Step #2. Note the proper orientation of the radial ring brackets in Figure A. Install ground strap (428) as shown in Figure D.

NOTE: Do not accidentally use the #10-24 nut in this step.

Insert four 2 1/2" screws (232) into the base assembly (BA) as shown in Figure D. Secure with nuts (87).









KEY	P/N	DISPLAY	DESC	SIZE	QTY
BA			BASE ASSEMBLY		1
73	194173		RADIAL RING BRACKET		4
74	194174		RADIAL RING		2
79	010079		SS MACHINE SCREW	# 8-32 x 1/2 (1.3 cm)	4
87	014387		SS LOCK NUT	# 8-32	14
96	010096		SS MACHINE SCREW	#8-32 x 3/8" (.95 cm)	4
232	010232		SS MACHINE SCREW	# 8-32 x 2-1/2" (6.35 cm)	6
428	902428		GROUND STRAP		1

FIGURE A

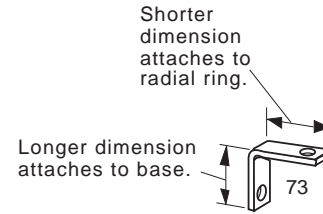


FIGURE B

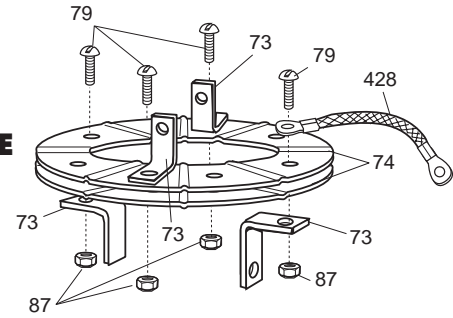


FIGURE C

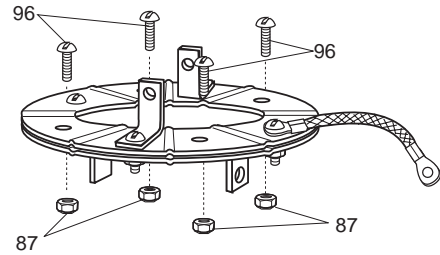
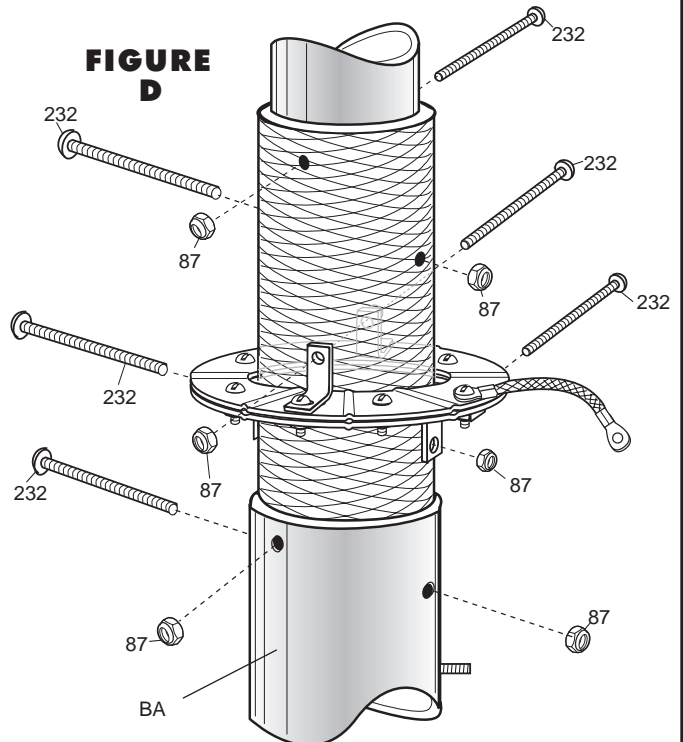


FIGURE D



TA5FA

#2 - ATTACH MATCHING NETWORK AND RADIALS

Slide upper matching network bracket (160) onto base section (BA). Place it tight against the fiberglass insulator. Insert one 2" screw (120) into bracket (160) and attach nut (87) as shown in Figure E. Slide Matching Network screws into holes on upper matching network bracket (160). Position bottom MN bracket over captive screw in base section (BA) and secure with #10 nut (220) and a #10 lock washer (233). Secure MN to upper MN bracket (160) with two nuts (11) and lock washer (941). Tighten screw in upper MN bracket (160). The radial rods may be inserted into the base section at any time in the assembly process.

One at a time, place the stainless radial rods (32) into the slots in the radial rings. Tighten the corresponding ring screws as you work your way around the rings. The radial rings do not have to touch each other to secure the radial rods properly. Do not overtighten the screws. When all rods are secure, tighten all hardware on the base section. Attach jumper strap (428) to MN screw with nut (11) and lock washer (941).

Attach warning labels (326) as shown.


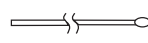


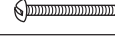





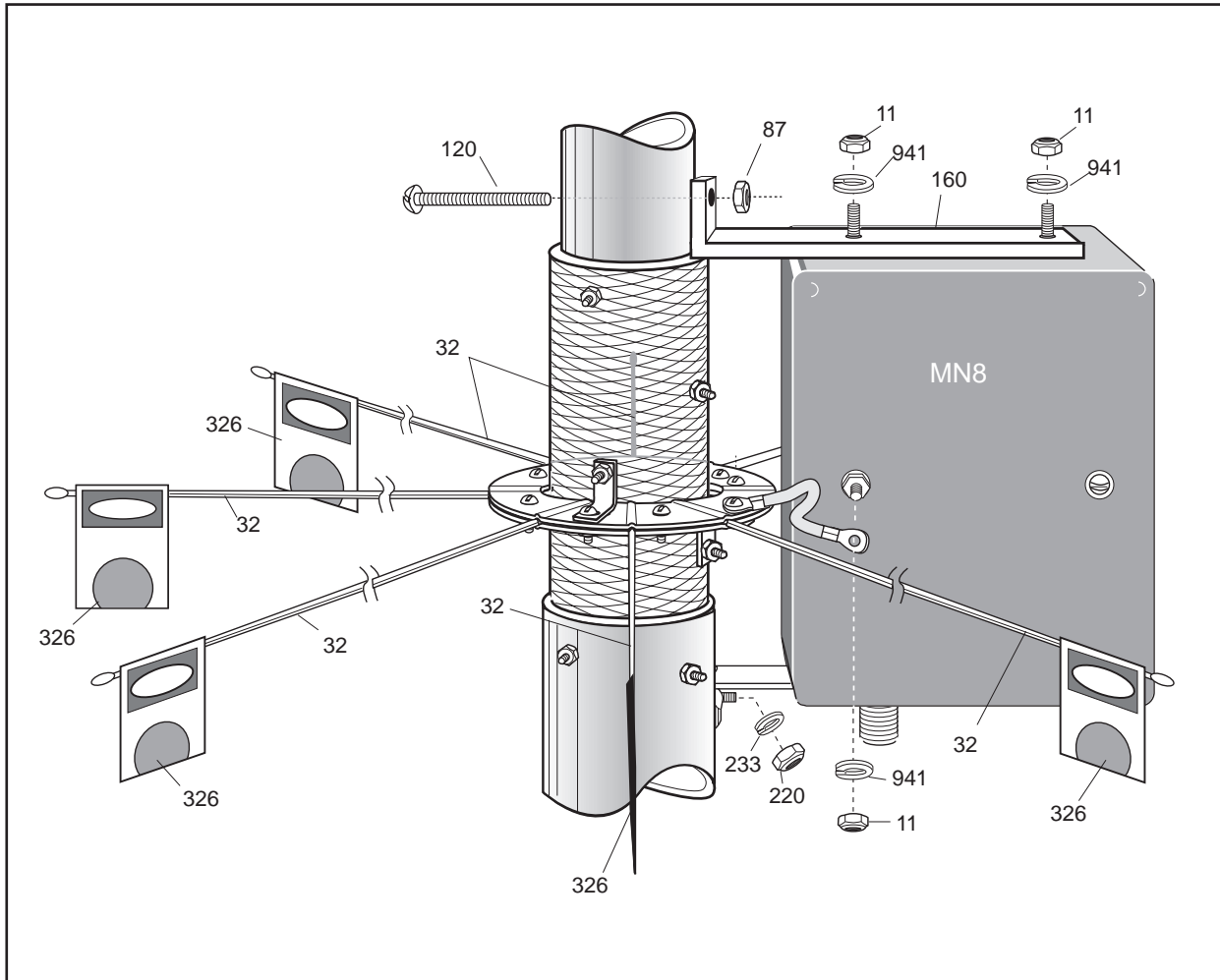
KEY	P/N	DISPLAY	DESC	SIZE	QTY
11	010011		SS HEX NUT	#8-32	3
32	902832		SS RADIAL	49" (124.5 cm)	7
160	190160		MN8 BRACKET		1
87	014387		SS LOCK NUT	#8-32	4
120	010120		SS MACHINE SCREW	# 8-32 x 2" (5.1 cm)	1
326	290326		WARNING LABEL		7
MN	MN8		MATCHING NETWORK		1
220	010220		SS HEX NUT	#10-24	1
233	010233		SS SPLIT LOCK WASHER	#10	1
941	011941		SS SPLIT LOCK WASHER	#8	3

FIGURE E



TA5FA

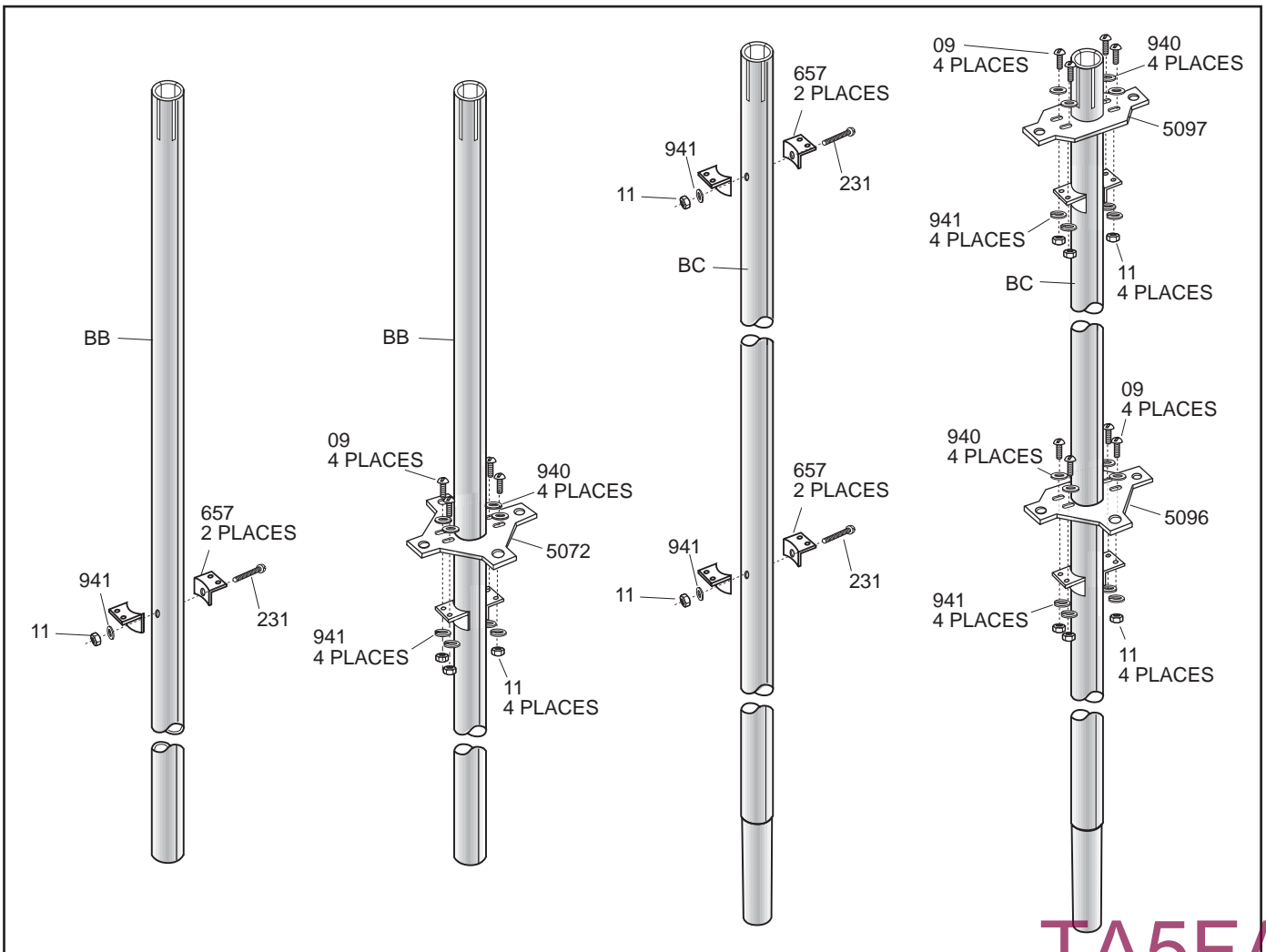
#3 - ASSEMBLE PLASTIC SPACERS TO RADIAL RINGS

Place the aluminum L-brackets (657) on tube (BB) and secure them with hardware (231,941&11). Repeat this as well on tube (BC) as shown on Fig. "F". Slide the 4-hole insulator (5072) on tube (BB) and secure it with applicable hardware (09, 940,941 & 11). Repeat the same with two and three hole insulators (5096 & 5097) on tube (BC) according to the Fig. "F".

NOTE: Make sure that the tubes are oriented with the slotted ends on the top when you start assembling the hardware onto them.

KEY	P/N	DISPLAY	DESC	SIZE	QTY
09	010009		SS Machine Screw	# 8-32 x 5/8" (1.6 cm)	12
11	010011		SS HEX NUT	8-32	15
941	011941		SS Split Lock Washer	# 8	15
231	010231		SS Machine Screw	8-32 x 1-3/4" (4.45 cm)	3
657	194657		Aluminum L Bracket		6
940	360940		Aluminum Flat Washer	# 8	12
BB	R8BB		R8 Tube	1-1/4" x 72" (3.2 x 182.9 cm)	1
BC	R8BC		R8 Tube	1-1/8" x 72" (2.9 x 182.9 cm)	1
5072	205072		4-Hole Insulator		1
5096	205096		3-Hole Insulator		1
5097	205097		2-Hole Insulator		1

FIGURE F



TA5FA

#4 - ASSEMBLE RADIATOR TUBES

Slide the Tube BD into tube BC until it hits the inner tube, and secure it with worm clamp (411). Slide this assembly into tube BB and secure it with worm clamp (412). Make sure that plastic insulators are aligned as shown in Fig. "G".

Insert assembly consisted of tubes BD, BC and BB 4 -1/2 " into base assembly (BA) and secure it with worm clamp (413). We recommend that you use workhorses or two chairs to place this assembly in a horizontal position . You may or may not attach the stainless radial rods (32) to the base assembly (BA) at this time as mentioned in Section #2 of this manual.

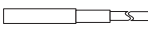
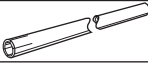
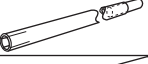
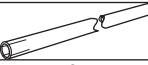



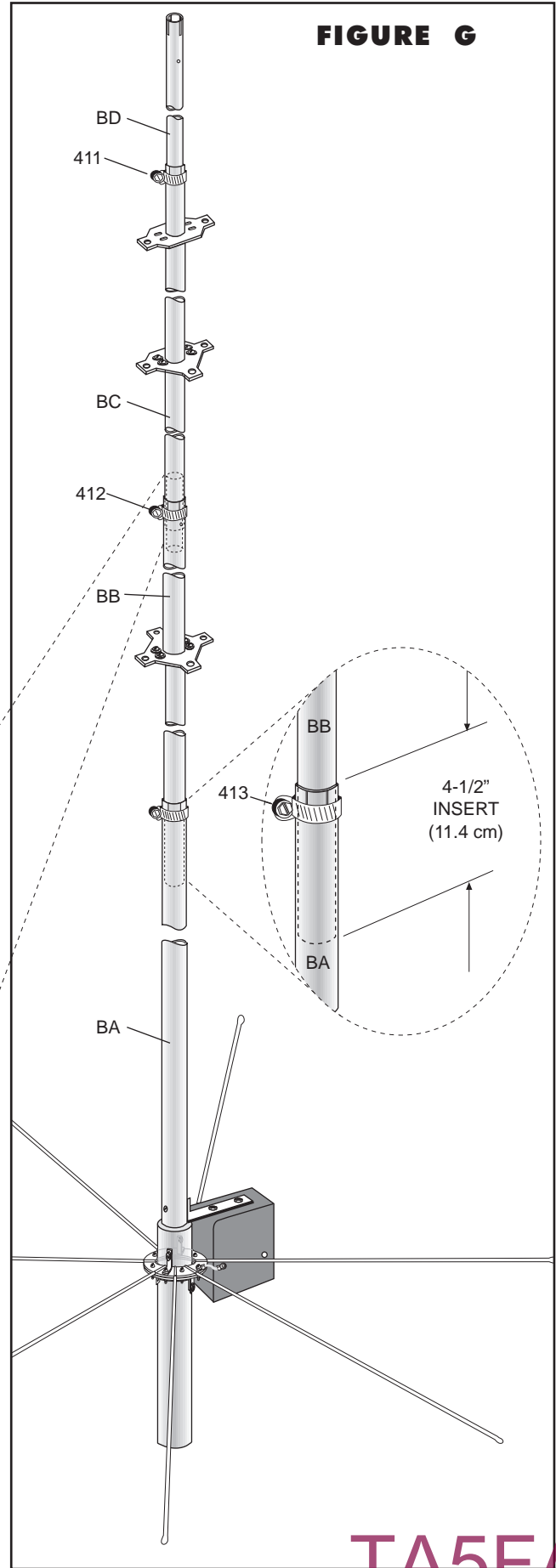
KEY	P/N	DISPLAY	DESC	SIZE	QTY
BA			BASE ASSEMBLY		1
BB			R8 TUBE BB	1-1/4" x 72" (3.17 x 182.9 cm)	1
BC			R8 TUBE BC	1-1/8" x 72" (2.9 x 182.9 cm)	1
BD			R8 TUBE BD	1" x 36" (2.5 x 91 cm)	1
411	030411		SS WORM CLAMP	9/16" x 1-1/4" (1.4 x 3.1 cm)	1
412	030412		SS WORM CLAMP	11/16" x 1-1/2" (0.7 x 3.8 cm)	1
413	030413		SS WORM CLAMP	3/4" x 1-3/4" (1.9 x 4.4 cm)	1

FIGURE G



TA5FA

#5 - ASSEMBLE METAL CLAMPS ON TO RADIATOR

As the antenna radiator sits on workhorses or pair of chairs place the aluminum stub clamps (99) on radiator according the Fig. "H". Make sure the clamps are aligned as shown. Leave the hardware on clamps (64, 87) slightly loose to allow you insert the stub tubes later.



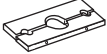
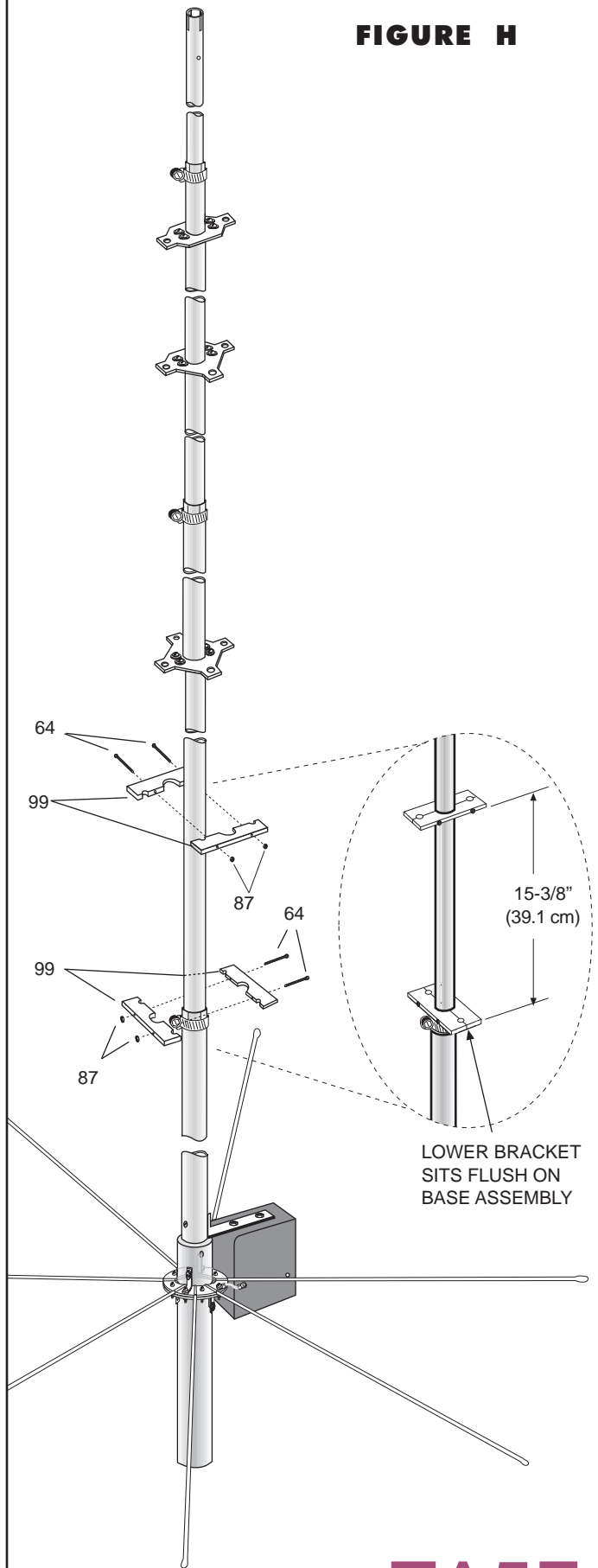
KEY	P/N	DISPLAY	DESC	SIZE	QTY
64	014764		SS MACHINE SCREW	#8-32 x 2-1/4" (5.7 cm)	4
87	014387		SS NYLON HEX NUT	#8-32	4
99	205099		ALUMINUM STUB CLAMP		2

FIGURE H




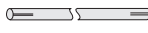





TA5FA

#6 - ASSEMBLY OF 6 AND 10 METERS STUBS

Take the (SA) tube and slide it through the 4-hole insulator and secure it in the bottom aluminum stub clamp as shown in Fig. "I". Make sure that the slotted end of (SA) tube protrudes beyond the 4-hole insulator and the opposite end of (SA) tube is mounted flush with the bottom of the stub clamp (see callout at bottom of Fig I). In same fashion slide the tube (SC) and secure it on other side of bottom aluminum stub clamp. Align the bottom stub clamp with plastic insulators and secure it tight. Slide the 6" rod (SB) into tube (SA) and secure with worm clamp (407). Use 6 Meter tuning chart to adjust the stub (SB) for selected portion of the band. Place the protective plastic cap on top of (SB) tuning rod to complete the 6 Meter stub.

Take another 6" rod (SB) and slide it 3" into tube (SC) and secure with worm clamp (407) as shown in callout of Fig. "I". Slide the tube (SD) through 3-hole plastic insulator and assemble with worm clamp (407) over other end of rod (SB). Insert rod (SE) into tube (SD) as shown, and complete the 10 Meter stub by placing the protective plastic cap on top.

KEY	P/N	DISPLAY	DESC	SIZE	QTY
SA	R8SA		R8 Stub SA	3/8" x 52" (1 x 132 cm)	1
SB	R8SB		R8 Stub SB	1/4" x 6" (0.6 x 15 cm)	2
SC	R8SC		R8 Stub SC	3/8" x 48" (1 x 121.9 cm)	1
SD	R8SD		R8 Stub SD	3/8" x 48" (1 x 121.9 cm)	1
SE	R8SE		R8 Stub SE	1/4" x 12" (.6 x 30.5 cm)	1
105	055105		Black Plastic Cap	1/4" (.6 cm)	2
407	030407		SS Worm Clamp	7/32"-5/8" (.6 x 1.6 cm)	4

6 Meter Tune Chart	
Frequency (MHz)	Length
50.250	4-1/2" (11.4 cm)
50.800	3-1/2" (8.9 cm)
51.500	2-1/2" (6.4 cm)
52.500	1-1/2" (13.8 cm)
53.500	1/2" (1.3 cm)

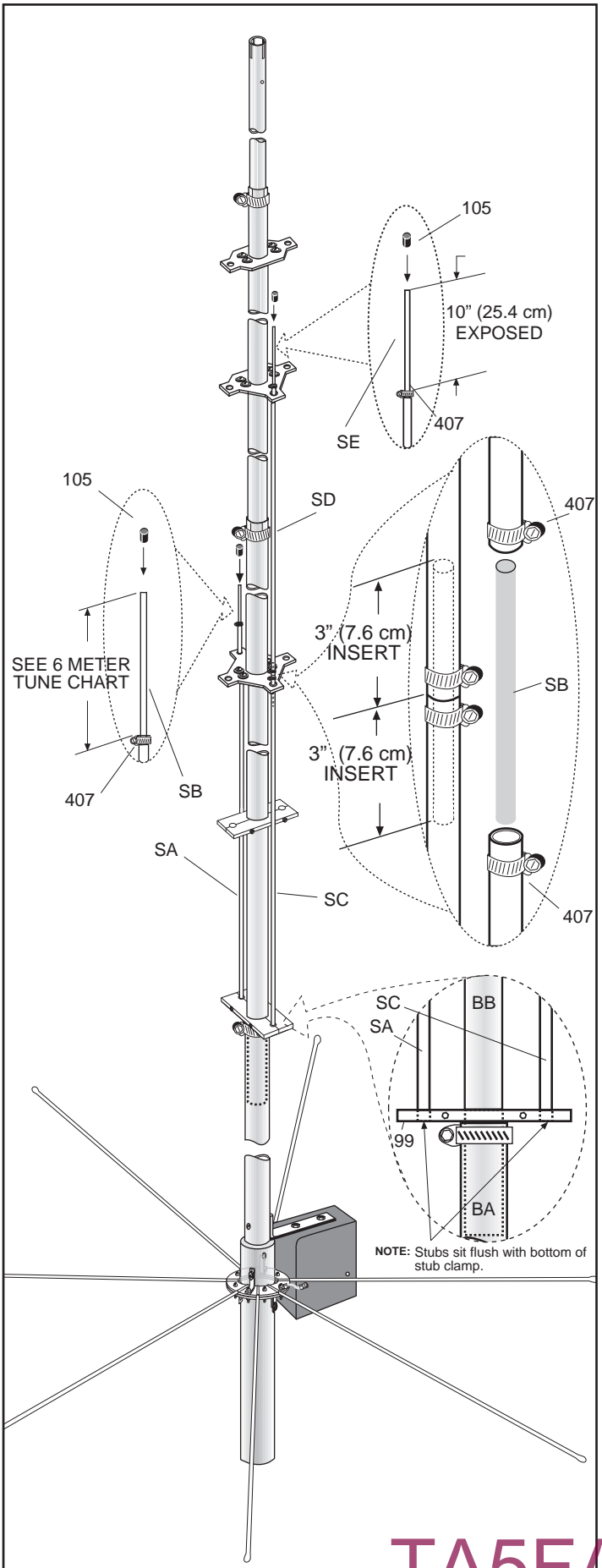


FIGURE I

TA5FA

#7 - ASSEMBLY OF 12 AND 15 METERS STUBS

Take two tubes (SF) and slide them through 4-hole plastic insulator and secure in top stub clamp as shown in Fig. J1. Insert two 6" rods (SB) in (SF) tubes and place the worm clamps (407) as shown in callout at Fig. J2. Place tube (SH) on left side stub as shown in Fig. J2, sliding it through 2 and 3 hole plastic insulators. Insert tube (SG) on the right side stub as shown and secure with worm clamp. Take two (SB) rods and insert them on top of these two stubs as shown in top callouts of Fig. J2 along with protective end caps.

Note: Make sure that all stubs are positioned around main radiator as shown in Fig. J2





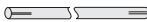

KEY	P/N	DISPLAY	DESC	SIZE	QTY
SB	R8SB		R8 STUB SB	1/4" x 6" (.6 x 15 cm)	4
105	055105		BLACK PLASTIC CAP	1/4" (.6 cm)	2
407	030407		SS WORM CLAMP	7/32"-5/8" (1.2 x 1.6 cm)	6
SF	R8SF		R8 STUB SF	3/8" x 72" (1 x 182.9 cm)	2
SH	R8SH		R8 STUB SH	3/8" x 68" (1 x 173 cm)	1
SG	R8SG		R8 STUB SG	3/8" x 43-1/2" (1 x 110.5 cm)	1

FIGURE J1

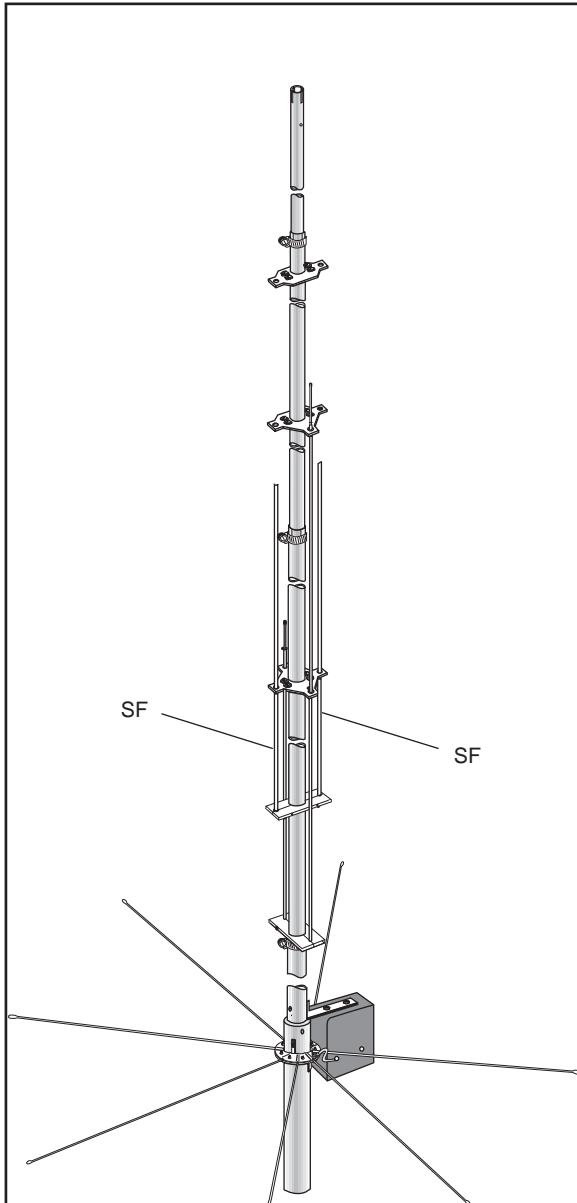
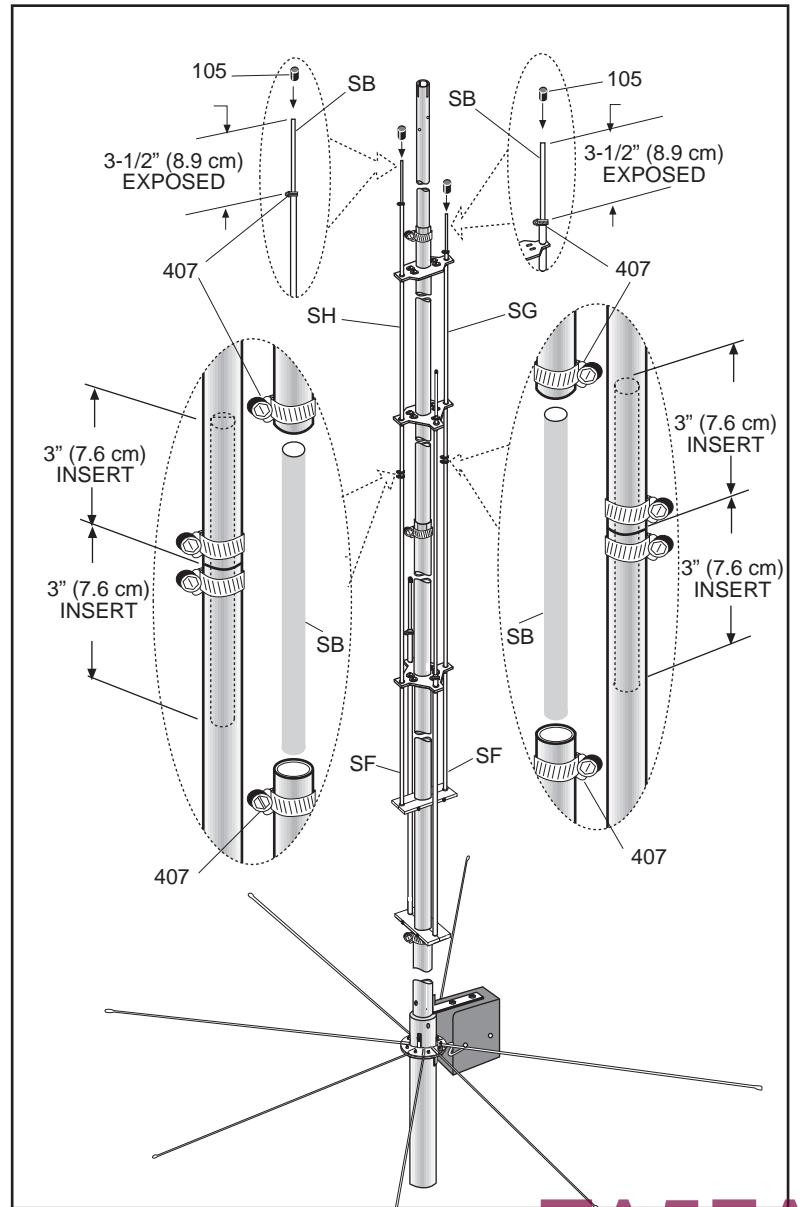






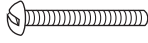
FIGURE J2



TA5FA

#8 - ASSEMBLE X-HAT ON BD TUBE

Install 2 X hat rods (XHR40) as shown in figure K, using aluminum bracket, (26), aluminum half washers (28), and fasten with screw (231) and lock nut (87).

KEY	P/N	DISPLAY	DESC	SIZE	QTY
XHR40	XHR40		X-Hat Rod	40" (101.6 cm)	2
26	190026		Aluminum Bracket		2
28	190028		Aluminum Half Washer		2
87	014387		SS Nylon Hex Nut	# 8-32	2
231	010231		SS RH Machine Screw	#8-32 x 1-3/4" (4.4 cm)	2

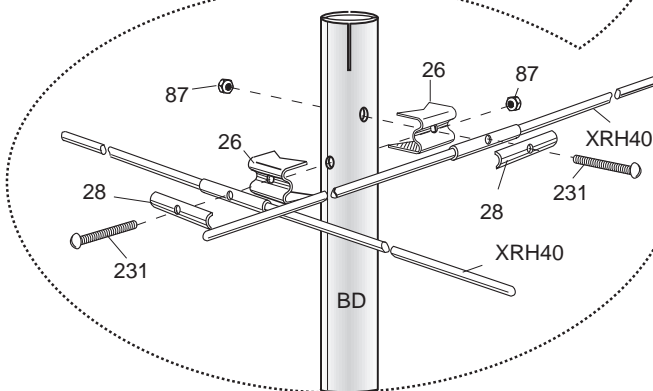
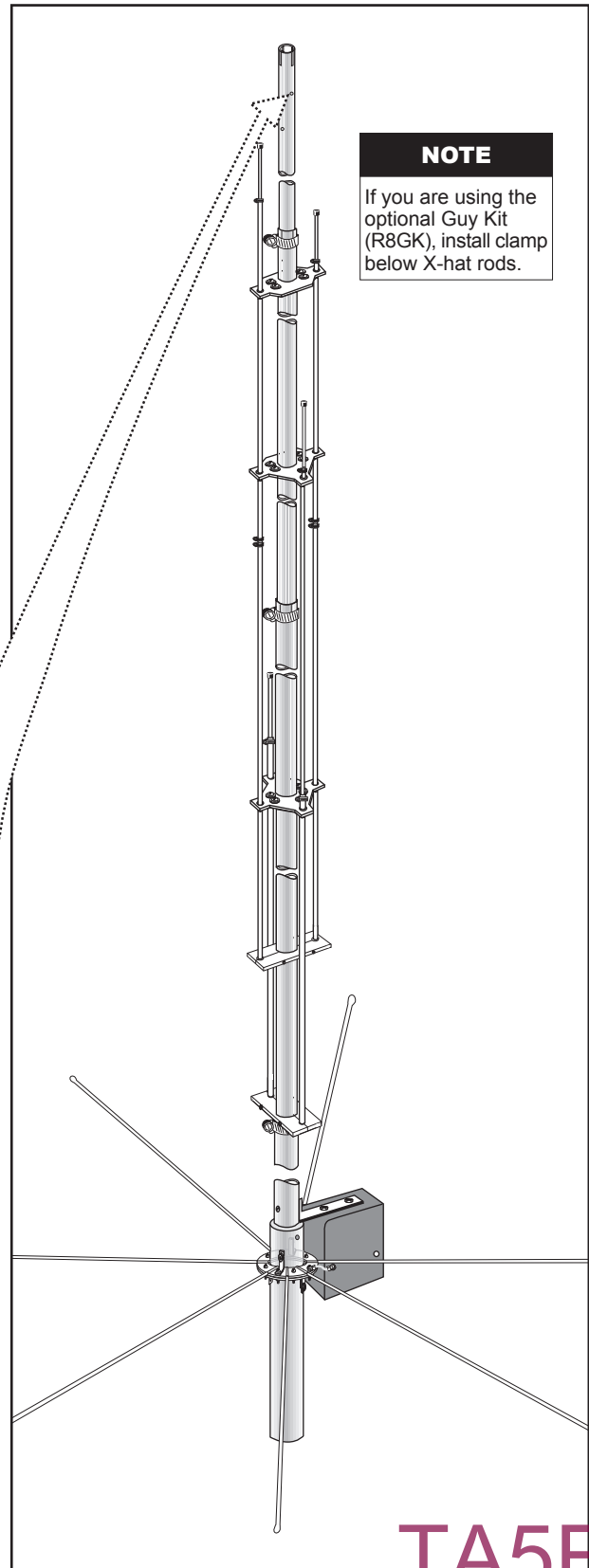


FIGURE K



NOTE






If you are using the optional Guy Kit (R8GK), install clamp below X-hat rods.

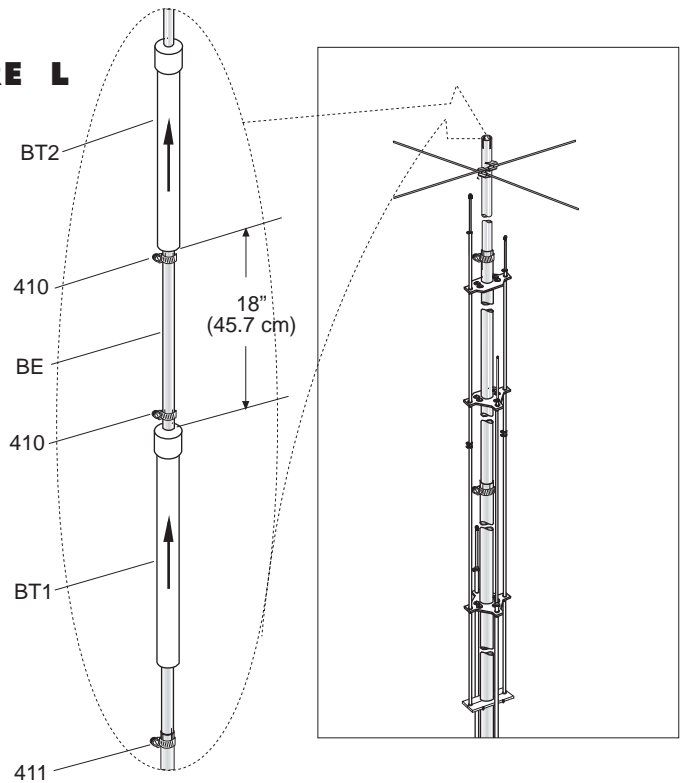
TA5FA

#9 - ASSEMBLE TRAPS

FIGURE L






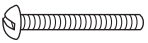




Assemble traps (BT1) and (BT2) as shown in callout of Fig."L". Slide this assembly into top tube (BD) of main radiator assembly until it hits the screws of X-hat assembly and secure it with worm clamp (411).

KEY	P/N	DISPLAY	DESC	SIZE	QTY
BT1			BT1 TRAP 17/20 METER		1
BT2			BT2 TRAP 30 METER		1
BE			R8 TUBE BE	7/8" x 16" (2.3 x 41 cm)	1
410	030410		SS WORM CLAMP	7/16"-1" (1.1 x 2.5cm)	2
411	030411		SS WORM CLAMP	9/16" x 1-1/4" (1.4 x 3.2 cm)	1



#10 - ASSEMBLE TOP RADIATOR WITH X-HAT

Take the tube (BG) and insert 2" into swedged tube (BF). Secure assembly with worm clamp (409). Slide tube (BH) into tube (BG) and adjust for selected portion of 40 Meters band according the 40 Meter Tuning chart. Install X-hats (XHR32) on swedged tube (BF) as shown in callout of Fig."M". Take this assembly and slide it over top trap (BT2) spacing the edge of (BF) 1" of the trap cap.

KEY	P/N	DISPLAY	DESC	SIZE	QTY
XHR32	XHR32		X-HAT ROD	32" (81 cm)	2
26	190026		ALUMINUM BRACKET		2
28	190028		ALUMINUM Half Washer		2
76	054276		END CAP	3/8" (0.9 cm)	1
87	014387		SS NYLON HEX NUT	# 8-32	2
231	010231		SS RH MACHINE SCREW	# 8-32 x 1-3/4" (4.4 cm)	2
409	030409		SS WORM CLAMP	3/8"-7/8" (0.9 x 2.2 cm)	1
410	030410		SS WORM CLAMP	7/16"-1" (1.1 x 2.5 cm)	1
BG	R8BG		R8 TUBE BG	1/2" x 24" (1.3 x 61 cm)	1
BH	R8BH		R8 TUBE BH	3/8" x 24" (0.9 x 61 cm)	1

Frequency (MHz)	Length (ln) (cm)	Frequency (MHz)	Length (ln) (cm)
7.025	20" (50.8)	7.200	10" (23.4)
7.050	18.5" (47.0)	7.250	7" (17.8)
7.100	16" (40.6)	7.300	5" (12.7)
7.150	13" (33.0)		

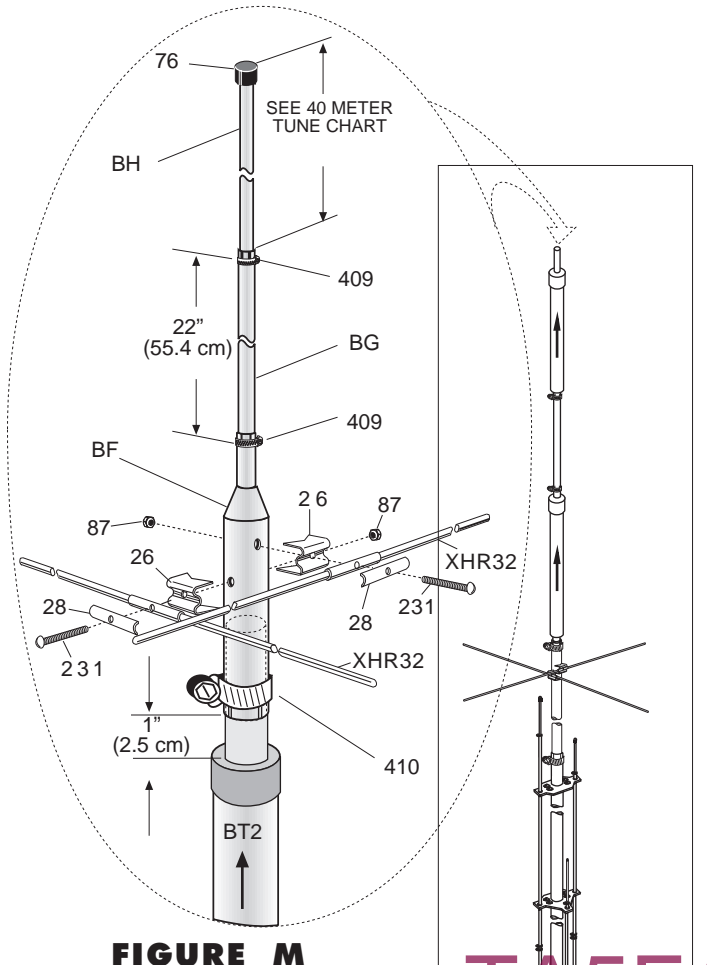
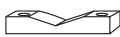







FIGURE M

TA5FA

#11 - BASE TO MAST ASSEMBLY

Attach the antenna base to your mast as shown in Figure N. First attach the mounting plate (4079) with U-bolts (404), aluminum V-blocks (63), and nut (389) to the antenna base. The bottom of the plate should be even with the bottom of the antenna to leave room for the radial clamping system. Affix danger label (326) to the antenna so that is easy to see. When attaching mounting plate to the mast use the (405) U-bolts, aluminum V-blocks (63), and nut (389).

KEY	P/N	DISPLAY	DESC	SIZE	QTY
63	170063		V-BLOCK	2" (5.1 cm)	4
389	014389		SS/NYLON LOCK NUT	5/16" (.8 cm)	8
404	010404		U-BOLT	5/16-18 x 3-1/4" (6.2 x 8.2 cm)	2
405	010405		U-BOLT	5/16-18 x 4-1/2" (6.2 x 11.4 cm)	2
4079	194079		MOUNTING PLATE		1
326	290326		WARNING LABEL		1

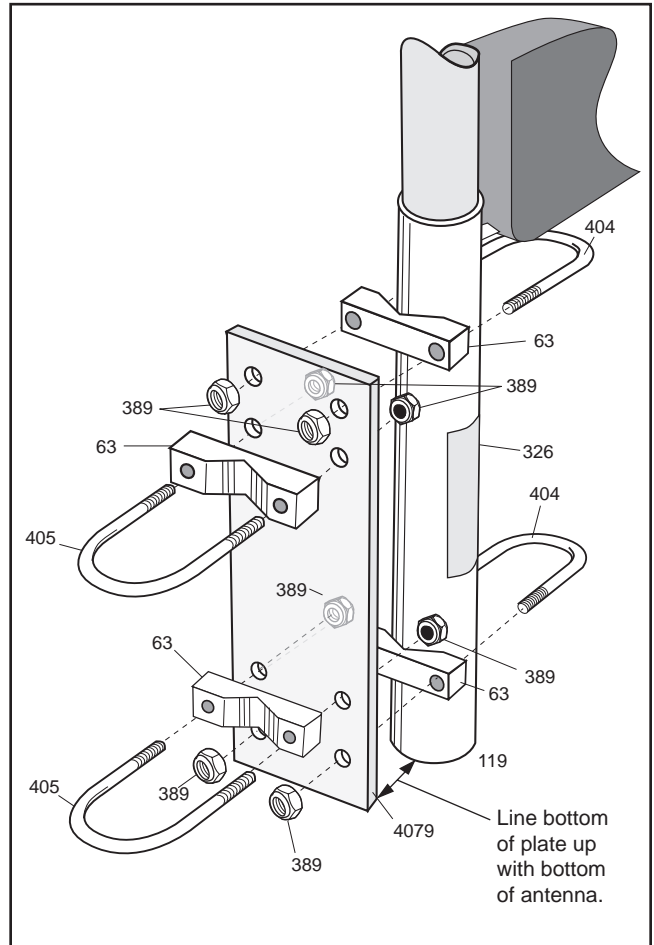




Figure N

#12 - FEEDLINE

The R8 is designed for use with 50 Ohm coaxial cable terminated with a PL-259 connector. The shortest length of cable will have the least loss. A connector boot is included for use with your new antenna (figure O). Slide the boot over the cable before attaching your PL-259. Coat only the outside connector threads and shell with silicone grease. Do not coat the center pin or receptacle. After the PL-259 is firmly screwed onto the antenna connector, slide the vinyl boot over the connector and against the connector bracket for a good weather-tight connection. After the antenna is on the mast, tape the feedline to the mast. If you plan to install the antenna in a salty or corrosive environment, you may want to consider coating it with a clear marine varnish or equivalent after it is assembled.

KEY	PART#	DESCRIPTION	SIZE	QTY
115	050115	 CONNECTOR BOOT		1
116	240116	 SILICONE PACKAGE		1

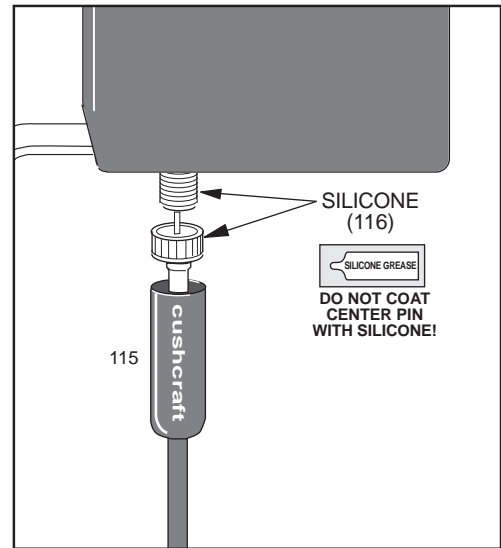


Figure O

R8 SPECIFICATIONS

Frequency, meters	6,10,12,15,17,20,30,40
Gain, dBi	3
VSWR 2:1 bandwidth, KHz	40m (150)
	30m (>50)
	20m (>350)
	17m (>100)
	15m (>450)
	12m (>100)
	10m (>1500)
	6m (>1500)
VSWR at resonance (typical)	1.3:1
Power Rating, Watts CW	1500
Vertical Radiation angle, deg.	16
Horizontal rad, deg.	360
Height, ft(m)	28.5 max. (8.7)
Wind survival	80 mph
Weight, lb. (kg)	23 (10.5)

The Electrical Specifications for all Cushcraft Amateur Antennas are derived from numerical analysis and measured data taken on our test range. Performance may vary due to the random variables associated with a specific application or installation.

LIMITED WARRANTY

Cushcraft Corporation, 48 Perimeter Road, Manchester, New Hampshire 03103, warrants to the original purchaser for one year from date of purchase that each Cushcraft antenna is free of defects in material or workmanship. If, in the judgement of Cushcraft, any such antenna is defective, then Cushcraft Corporation will, at its option, repair or replace the antenna at its expense within thirty days of the date the antenna is returned (at purchasers expense) to Cushcraft or one of its authorized representatives. This warranty is in lieu of all other expressed warranties, any implied warranty is limited in duration to one year. Cushcraft Corporation shall not be liable for any incidental or consequential damages which may result from a defect. Some states do not allow limitations on how long an implied warranty lasts or exclusions or limitations of incidental or consequential damages, so the above limitation and exclusion may not apply to you. This warranty gives you specific legal rights, and you may also have other rights which vary from state to state. This warranty does not extend to any products which have been subject the misuse, neglect, accident or improper installation. Any repairs or alterations outside of the Cushcraft factory will nullify this warranty.



48 PERIMETER ROAD, MANCHESTER, NH 03103 USA
TELEPHONE: 603-627-7877 • FAX: 603-627-1764 • E-mail: techsup@cushcraft.com

SPECIFICATIONS SUBJECT TO CHANGE WITHOUT NOTICE

TA5FA