



**ASSEMBLY &
INSTALLATION**



X940
40 Meter ADD-ON KIT FOR X9



CUSHCRAFT
COMMUNICATIONS ANTENNAS

TA5FA

951471 (8/98)

X940

Thank you for your purchase of the Cushcraft X940 40 meter add-on kit. This kit is designed and manufactured to give the best performance and trouble free service. The antenna will perform as specified if the instructions are followed during assembly and installation. If you have technical questions and have access to the World Wide Web you can visit Cushcraft's **TECHEXPRESS** support service (<http://www.cushcraft.com>). The site enables the user to place parts orders, ask technical questions, locate part numbers, initiate warranty inquiries and review *Frequently Asked Questions*. Our technical support staff can be reached by phone at (603) 627-7877 (8 AM to 5 PM Eastern time or voice mail after hours), faxed at (603) 627-1764 or can be e-mailed at techsup@cushcraft.com.

WARNING

THIS ANTENNA IS AN ELECTRICAL CONDUCTOR. CONTACT WITH POWER LINES CAN RESULT IN DEATH OR SERIOUS INJURY. DO NOT INSTALL THIS ANTENNA WHERE THERE IS ANY POSSIBILITY OF CONTACT WITH OR HIGH VOLTAGE ARC-OVER FROM POWER CABLES OR SERVICE DROPS TO BUILDINGS. THE ANTENNA, SUPPORTING MAST AND/OR TOWER MUST NOT BE CLOSE TO ANY POWER LINES DURING INSTALLATION, REMOVAL OR IN THE EVENT PART OF THE SYSTEM SHOULD ACCIDENTALLY FALL. FOLLOW THE GUIDELINES FOR ANTENNA INSTALLATION RECOMMENDED BY THE U.S. CONSUMER PRODUCT SAFETY COMMISSION AND LISTED IN THE ENCLOSED PAMPHLETS.

Antenna System Planning

Before assembly, take time to review your installation plans for the antenna. Location of the antenna is very important. Surrounding objects such as trees, power lines, buildings, and other antennas will interact with an HF Yagi. To minimize the effects of surrounding objects, mount the antenna as high and in the clear as possible. Metallic guy wire within 30 feet of this antenna, if broken with strain insulators, will improve performance. **YOU MUST INSURE THAT NEITHER PEOPLE OR PETS CAN COME IN CONTACT WITH YOUR ANTENNA WHILE IT IS IN OPERATION. DEADLY VOLTAGES AND CURRENTS MAY EXIST. ALSO, SINCE THE EFFECTS OF EXPOSURE TO RF ARE NOT FULLY UNDERSTOOD, LONG TERM EXPOSURE TO INTENSE RF FIELDS IS NOT RECOMMENDED. THERE IS A WARNING STICKER WHICH MUST BE ATTACHED TO THE BOOM AS SHOWN IN FIGURE A.** Plan your installation carefully. If you use volunteer helpers be sure that they are qualified to assist you. Make certain that everyone involved understands that you are in charge and that they must follow your instructions. If you have any doubts at all, employ a professional antenna installation company to install your antenna.

System Grounding

Direct grounding of the antenna, mast and tower is very important. This serves as protection from lightning strikes and static buildup. A good electrical connection should be made to one or more ground rods directly at the base of the tower or mast using at least #10 AWG ground wire and non-corrosive hardware. For details and safety standards, consult the National Electrical Code. A coaxial lightning arrester should be used. Cushcraft offers several different models such as the LAC series.

Assembly

The assembly procedure for the X940 consists of assembling the following subassemblies. **1) Verification of Parts. 2) Element Assembly 3) Element to Boom Assembly. 4) Feed System Assembly. 5) Element Truss Assembly. 6) X-hat Assembly 7) Boom-to-Mast Mount Relocation.** Assembly of the X940 will be easiest if the preceding steps are performed in the given order. However, depending upon your installation, you may prefer to perform step 7 before the element assembly is mounted to the boom. **Please read through the entire assembly procedure before beginning.**

1-Verification of Parts

Verify all parts are present by using the X940 Master Parts List. Check off each part when it is counted. There are extra parts intentionally shipped with this antenna. Place common hardware in temporary containers for ease of assembly. Note all hardware is Stainless Steel.

Part No.	Description	Metric Equiv	Quantity	Part No.	Description	Metric Equiv	Quantity
010011	#8-32 SS Nut		2	050131	1-1/8" Plastic Cap	2.9 cm	1
010082	1/4-20 x 1" SS Hex Bolt	2.5 cm	9	094622	30' Roll of Phyllystran Cable	9.1 m	1
010084	1/4" SS Lock Washer	0.6 cm	24	124567	1" x 8" Drilled Fiberglass Insulator	2.5 x 20.3 cm	1
010085	1/4-20 SS Nut	0.6 cm	2	190026	Formed Aluminum Bracket		5
010104	1/4" SS Flat Washer	0.6 cm	2	190028	Formed Aluminum Half Washer		4
010207	3/8" SS Flat Washer	0.9 cm	2	194707	4" x 24" Drilled U-Channel Bracket	10.2 x 61 cm	1
010212	1/4-20 x 2" SS Hex Bolt	5.1 cm	2	200088	1" Diameter Formed Aluminum Clamp	2.5 cm	2
010231	#8-32 x 1-3/4" SS Machine Screw	38 x 4.4 cm	6	290326	Warning sticker		1
010232	#8-32 x 2-1/2" SS Machine Screw	6.4 cm	1	321045	3/8" Aluminum Spacer	1.0 cm	2
011941	#8 SS Lock Washer		11	323718	Extruded Al V-Block		1
014387	#8-32 SS/Nylon Hex Lock Nut		9	324071	Black Plastic Insulator		1
014399	1/4-20 SS/Nylon Hex Lock Nut	0.6 cm	24	324509	4 x 5 1/4" x 3/16" Drilled Al Bracket	10.2 x 13.3 x 0.5 cm	2
014497	1 1/4" Cush-a-Clamp	3.2 cm	6	EA	1-1/4" x 72" Drilled&slotted Al Tube w/insert	3.2 x 183 cm	2
014588	1/4" x 3 1/2" SS Hex Bolt	0.6 cm x 8.9 cm	1	EB	1-1/8" x 48" Al Tube slotted 1 end	2.8 cm x 183 cm	2
014592	1/4" Flat Washer 1/8" thick	0.6 cm x 0.3 cm	2	EC	1" x 48" Aluminum Tube slotted 1 end	2.5 x 183 cm	2
024259	1/8" Thimble	0.3 cm	2	ED	1/2" x 48" Aluminum Tube slotted 1 end	1.3 x 183 cm	2
024624	1/8" Cable Clamp	0.3 cm	6	EE	3/8" x 36" Aluminum Tube	1.0 x 91 cm	2
030407	5/8" Worm Clamp	1.6 cm	2	EF	1-1/8" x 18" Aluminum Tube drilled 1 end	2.8 cm x 45.7 cm	1
030409	1-1/16" Worm Clamp	1.7 cm	2	LCA	40 Meter Loading Coil		2
030411	1-1/8" Worm Clamp	2.9 cm	4	MNX740	X940 Matching Network		1
030412	1-1/2" Worm Clamp	3.8 cm	2	XHR	3/8" x 34 1/2" Aluminum Rod drilled in center	1.0 x 87.6 cm	4
032881	2-3/4" Worm Clamp	7 cm	2	X79FS	1/2" Tinned Copper Braid 6" Long with Lugs	1.2 cm x 15 cm	2
050077	3/8" Plastic Cap	1 cm	2				

TA5FA

2 - Element Assembly

Figure A and B show the steps required for element assembly. Identify the parts required using the Element Subassembly Parts List. Slide EA sections over fiberglass insulator (567) until #8 screw holes line up. Insert screws (231) through holes and secure with lock washer (941) and nut (11). Insert EB tubes 4" (10.2 cm) into EA slotted ends until they stop against the EA insert tube and secure with worm clamp (412). Insert EC tubes 4" (10.2 cm) into slotted ends of EB and secure with worm clamp (411). Insert ED tubes 4" (10.2 cm) into slotted ends of LCA coils and secure with worm clamp (409). Insert EE tubes into ED tubes and adjust the element half lengths per Chart A. Secure EE tube with worm clamp (407). Place plastic caps (77) on ends of EE

Center Frequency (MHz)	Element Half Length Inches	Meters
7.000	250	6.35
7.075	248	6.30
7.150	246	6.25
7.225	244	6.20
7.300	242	6.15

ID	Part #		Description	Dimensions	Qty
11	010011		SS Nut	#8-32	2
26	290326		Warning Sticker		1
41	011941		SS Lock Washer	#8	2
77	050077		Black Plastic Cap	3/8" (0.9 cm)	2
231	010231		SS Machine Screw	#8-32 x 1-3/4" (4.4 cm)	2
407	030407		Worm Clamp	5/8" (1.6 cm)	2
409	030409		Worm Clamp	11/16" (1.7 cm)	2
411	030411		Worm Clamp	1-1/8" (2.9 cm)	4
412	030412		Worm Clamp	1-1/2" (3.8 cm)	2
567	124567		Fiberglass Insulator	1" x 8" (2.5 x 20.3)	1
EA			Aluminum Tube	1-1/4" x 72" (3.2 x 183 cm)	2
EB			Aluminum Tube	1-1/8" x 48" (2.8 x 183 cm)	2
EC			Aluminum Tube	1" x 48" (2.5 x 183 cm)	2
ED			Aluminum Tube	1/2" x 48" (1.3 x 183 cm)	2
EE			Aluminum Tube	3/8" x 36" (1.0 x 91 cm)	2
LCA	LCA		Loading Coil		2

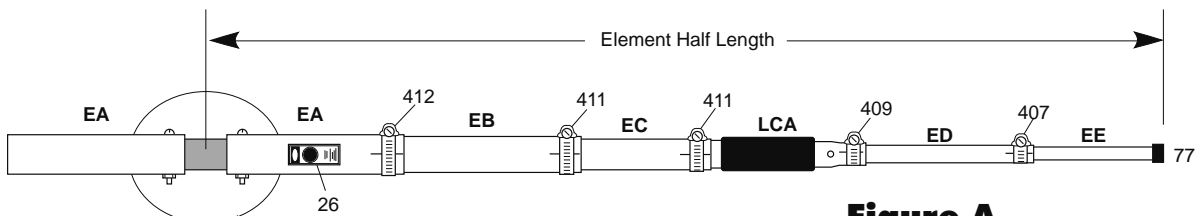

Figure A

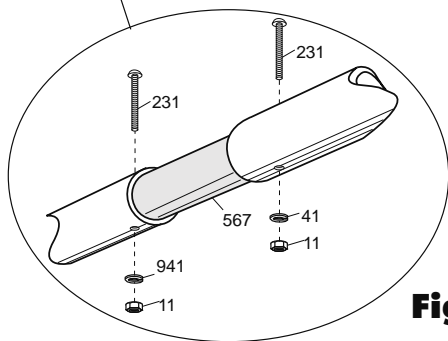
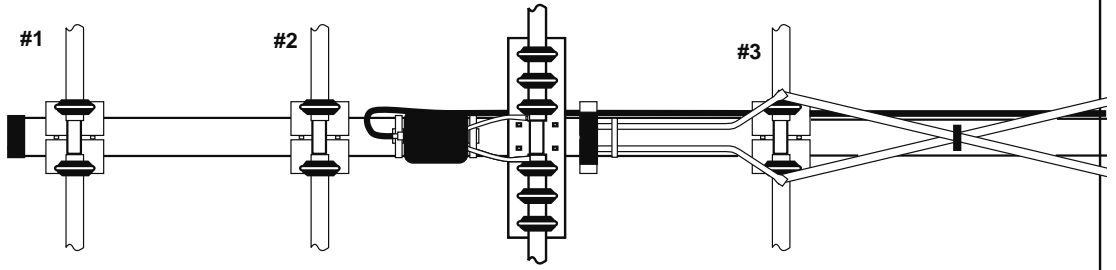

Figure B



3 - Element to Boom Assembly

Figure C, D and E show the steps for element mounting on the X9 Boom. Identify the parts required using the Element to Boom Subassembly Parts List. Attach the two 4" x 5 1/4" Extruded AL Brackets (509) to the X9BA boom section in the unused hole between X9 elements #2 and #3. Use the hardware shown. Tighten the bolts in the order shown. Attach the U-Channel Plate (707) to the Element EA sections using 6 Cush-a-Clamps (97) and the 1/4" Lock Washers (84) and 1/4-20 Nylon Lock Nuts (99). Center the fiberglass insulator (567) in the center of the U-Channel bracket (707). Insure the #8 hardware in the fiberglass insulator (567) is parallel to the boom with the #8 nuts (11) towards the rear of the boom (reflector end), see Figure F. Attach the Element to the Boom by bolting the U-Channel bracket (707) to the element brackets (509) using the 1/4" hardware shown in Figure E. Place 1/4-20 bolt (82) thru holes in V-Block (18) and attach hardware as shown. Leave bolt loose until Step 6.

Figure C

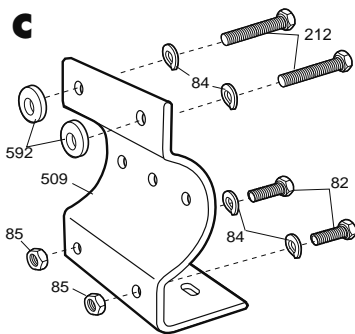

Figure D

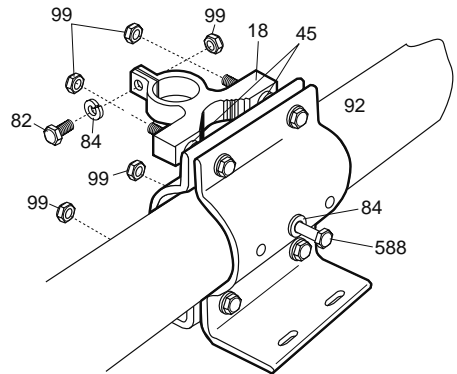
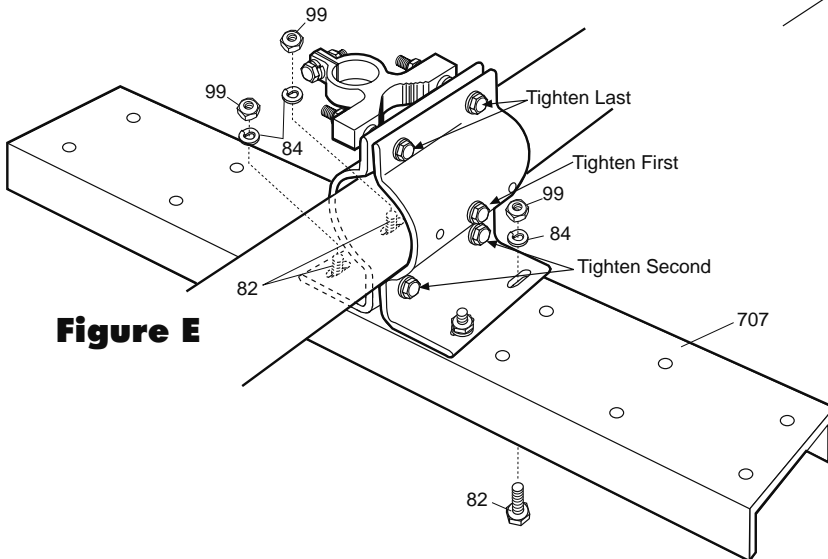
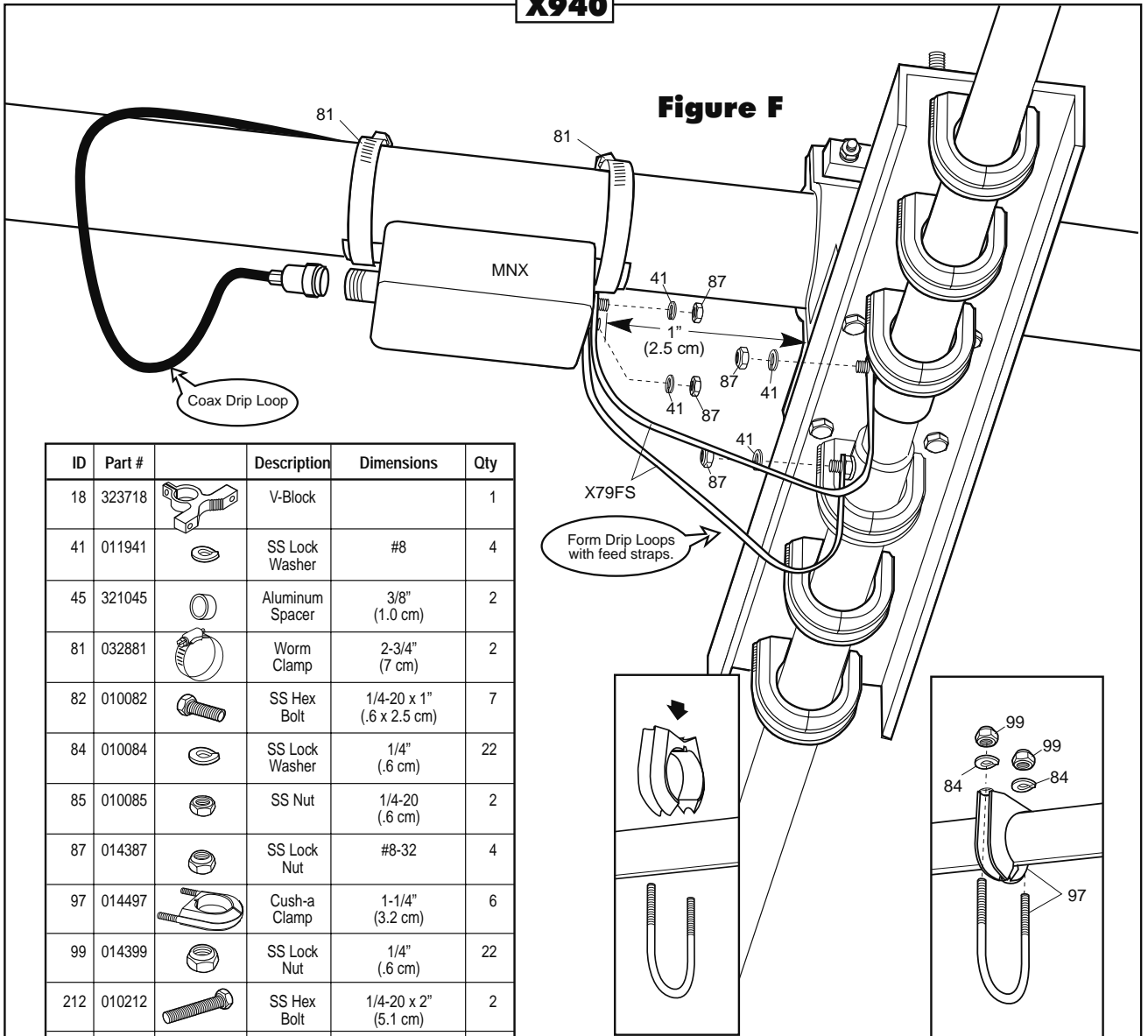

Figure E



TA5FA

Figure F









ID	Part #	Description	Dimensions	Qty
18	323718	V-Block		1
41	011941	SS Lock Washer	#8	4
45	321045	Aluminum Spacer	3/8" (1.0 cm)	2
81	032881	Worm Clamp	2-3/4" (7 cm)	2
82	010082	SS Hex Bolt	1/4-20 x 1" (.6 x 2.5 cm)	7
84	010084	SS Lock Washer	1/4" (.6 cm)	22
85	010085	SS Nut	1/4-20 (.6 cm)	2
87	014387	SS Lock Nut	#8-32	4
97	014497	Cush-a Clamp	1-1/4" (3.2 cm)	6
99	014399	SS Lock Nut	1/4" (.6 cm)	22
212	010212	SS Hex Bolt	1/4-20 x 2" (5.1 cm)	2
509	324509	Aluminum Bracket	4" x 5-1/4 x 3/16" (10.2 x 13.3 x .5 cm)	2
588	014588	SS Hex Bolt	1/4" x 3-1/2" (.6 x 10.2 cm)	1
592	014592	SS Flat Washer	1/4" (1/8" thick) (.6 x .3 cm)	2
707	194707	U-Channel Bracket	4" x 24" (10.2 x 61 cm)	1
MNX	MNX740	Matching Network		1
X79FS		Copper Braid	1/2" x 6" (1.2 x 15 cm)	2

4 - Feed System Assembly

Figure F shows the steps for feed system assembly. Identify the parts required using the Feed System Subassembly Parts List. Position the Matching Network (MNX) on the bottom of the X9 boom on the reflector side of the 40 meter driven element. Space the MNX feed screws 1" (2.5 cm) from the U-Channel driven element (707). Secure the MNX to the boom using two worm clamps (81). Attach the Feed Straps (FS) to the two screws on the MNX and the two driven element screws with the hardware shown. Position the Feed Straps away from the U-Channel bracket (707).

5 - X-Hat Assembly

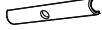
Figure G shows the steps for assembly of the two X-Hats. Identify the parts required using the X-Hat Subassembly Parts List. Two XHR rods attach to each 40 meter coil (LCA). Use the hardware shown in Figure G. The rods may be mounted in any position relative to the element or boom.

ID	Part #		Description	Dimensions	Qty
31	010231		SS Machine Screw	#8-32 x 1-3/4" (4.4 cm)	4
41	011941		SS Lock Washer	#8	4
87	014387		SS Lock Nut	#8-32	4
26	190026		Aluminum Bracket		4
28	190028		Aluminum Half Washer		4
XHR			Aluminum Rod	3/8" x 34-1/2" (1.0 x 87.6 cm)	4

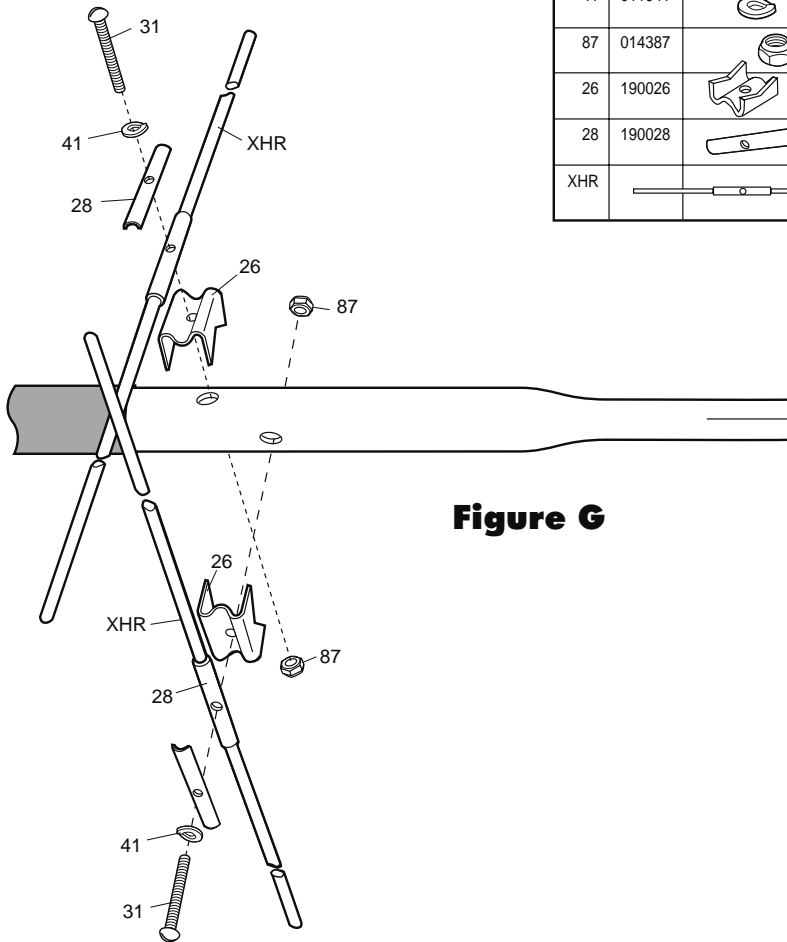

Figure G

6 - Element Truss Assembly

Figures H, I, J and K show the steps for assembly of the element truss. The truss is not required for mechanical strength, it is provided so the 40 meter element will have the same form as the other X9 elements. The 40 meter element is mechanically designed for 90+ mph wind survival without the truss. Identify the parts required using the Element Truss Subassembly Parts List. Place 1" (2.5 cm) clamps (88) on EC sections of element 2" (5.1 cm) from the slotted end of EC. Use the hardware called out in Figure J. Compress the clamp completely. Refer to Figure I and insert the EF tube into the hole in the V-Block (18). Slide EF as far down as possible. Attach Insulator (71) to drilled end of EF using hardware shown in Figure H. Connect one end of Phillystran cable (22) to one of the element clamps (88) using three cable clamps (24). Loop the Phillystran cable through the insulator and attach the loose end to the other element clamp (88) while keeping the cable tight. Secure the cable with 3 cable clamps (24).

Place plastic cap (31) on drilled end of EF tube. Adjust the 40 meter element to match the other elements by raising the EF tube. Tighten V-Block (18) bolt to secure EF tube.

Figure J

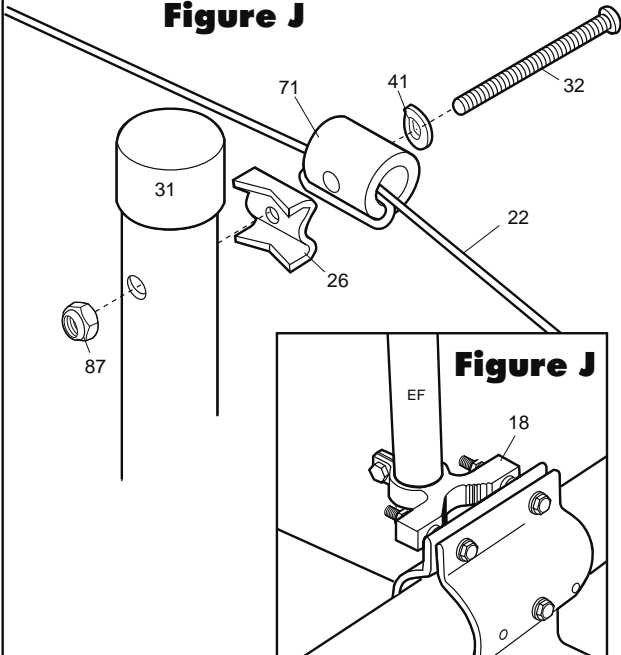

Figure J

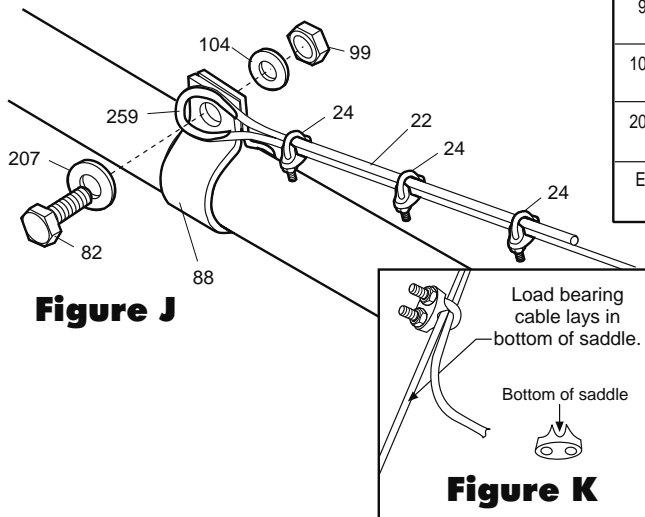

Figure J

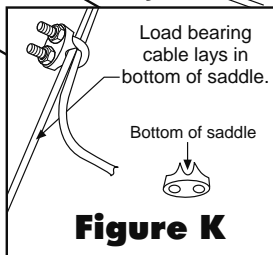
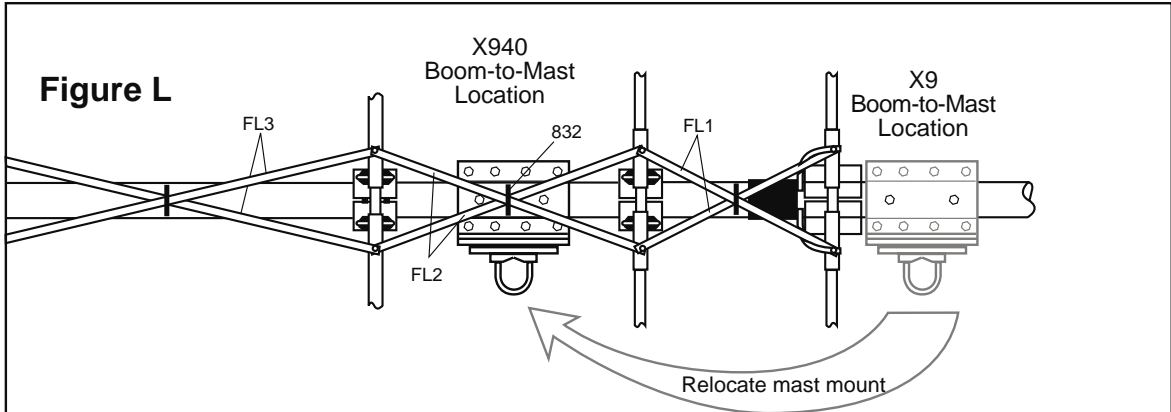

Figure K

ID	Part #		Description	Dimensions	Qty
22	094622		Phillystran Cable	1/8" x 30' (.3 x 9.1m)	1
24	024624		Cable Clamp	1/8" (.3 cm)	6
26	190026		Aluminum Bracket		1
31	050131		Plastic Cap	1-1/8" (2.9 cm)	1
32	010232		SS Machine Screw	#8-32 x 2-1/2 (6.4 cm)	1
41	011941		SS Lock Washer	#8	1
59	024259		Thimble	1/8" (.3 cm)	2
71	324071		Black Plastic Insulator		1
82	010082		SS Hex Bolt	1/4-20 x 1" (2.5 cm)	2
84	010084		SS Lock Washer	1/4" (.6 cm)	2
87	014387		SS Lock Nut	#8-32	1
88	200088		Aluminum Clamp	1" (2.5 cm)	2
99	014399		SS Lock Nut	1/4-20 (.6 cm)	2
104	010104		SS Flat Washer	1/4" (.6 cm)	2
207	010207		SS Flat Washer	3/8" (.95 cm)	2
EF			Aluminum Tube	1-1/8" x 18" (2.8 x 45.7)	1



7 - Relocation of X9 Boom-to-Mast Clamp

The X9 boom-to-mast clamp assembly must be moved when the X940 add-on kit is installed. This is necessary to balance the antenna on the tower mast.

First remove the FL2 feedline straps from the X9 boom. The Boom Truss Assembly has to be dismantled and later reassembled with different cable lengths. Remove the bolts and top plate holding the boom and relocate the assembly to the new location shown in Figure L, above. The assembly must be centered between the two elements as shown in Figure L. New holes must be drilled in the boom to accommodate the 1/4" x 3-1/2" (.63 x 8.9 cm). Use the aluminum brackets as a drill template and a 9/32" (7mm) diameter drill to drill through the wall of the boom section. Drill four places, twice from the top and twice from the bottom, to break through only one wall of the boom each time. Secure the boom-to-mast assembly and reattach the FL2 feedline straps.

Limited Warranty

Cushcraft Corporation, 48 Perimeter Road, Manchester, New Hampshire 03103, warrants to the original consumer purchaser for one year from date of purchase that each Cushcraft antenna is free of defects in material or workmanship. If, in the judgement of Cushcraft, any such antenna is defective, then Cushcraft will, at its option, repair or replace the antenna at its expense within thirty days of the date the antenna is returned (at purchaser's expense) to Cushcraft or one of its authorized representatives. This warranty is in lieu of all other expressed warranties.

Any implied warranty is limited in duration to one year. Cushcraft Corporation shall not be liable for any incidental or consequential damages which may result from a defect. Some states do not allow a limitation on how long an implied warranty lasts or exclusions or limitations of incidental or consequential damages, so the above limitation and exclusion may not apply to you. This warranty gives you specific legal rights, and you may also have other rights which vary from state to state.

This warranty does not extend to any products which have been subject to misuse, neglect, accident or improper installation. Any repairs or alterations outside of the Cushcraft factory will nullify this warranty.

SPECIFICATIONS For X9 with X940 Kit Installed

Frequency Coverage (Meters)	10, 15, 20, 40
Total number of Elements	8
Free Space Gain (dBi)	40M 2.0 20M 8.25 15M 9.75 10M 9.75
Maximum Front to Back Ratio (dB)	30 (0 on 40M)
Number of Elements per Band	3 (1 on 40M)
VSWR Minimum	1.1:1
VSWR 1.5:1 Bandwidth (KHz)	40M 100 20M 600 15M 750 10M 1700
Longest Element, ft (m)	41 (12.5)
Turning Radius, ft (m)	20.0 (6.09)
Boom Length, ft (m)	18 (5.49)
Boom Diameter, in (cm)	2-1/2 (6.35)
Maximum Mast Diameter OD, in (cm)	2-1/2 (6.35)
Maximum Wind Survival, mph (kph)	>100 (>161)
Maximum Wind Surface Area, ft ² (m ²)	9.9 (.92)
Windload @ 80 mph, lb (kg)	253 (114.8)
Maximum Power Handling (KW)	2
Weight, lb. (kg)	80 (36.3)
Design Safety Factor	1.25



CUSHCRAFT
COMMUNICATIONS ANTENNAS