



**ASSEMBLY &
INSTALLATION**



XM515
15 METER 5 ELEMENT YAGI



CUSHCRAFT
COMMUNICATIONS ANTENNAS

TA5FA
981483 (12/98)

XM515

Thank you for your purchase of the Cushcraft XM515 . This antenna is designed and manufactured to give the best performance and trouble free service. The antenna will perform as specified if the instructions are followed during assembly and installation. If you have technical questions and have access to the World Wide Web you can visit Cushcraft's **TECHEXPRESS** support service (<http://www.cushcraft.com>). The site enables the user to place parts orders, ask technical questions, locate part numbers, initiate warranty inquires and review *Frequently Asked Questions*. Our technical support staff can be reached by phone at (603) 627-7877 (8 AM to 5 PM Eastern time or voice mail after hours), faxed at (603) 627-1764 or can be e-mailed at techsup@cushcraft.com.

THIS ANTENNA IS AN ELECTRICAL CONDUCTOR. CONTACT WITH POWER LINES CAN RESULT IN DEATH OR SERIOUS INJURY. DO NOT INSTALL THIS ANTENNA WHERE THERE IS ANY POSSIBILITY OF CONTACT WITH OR HIGH VOLTAGE ARC-OVER FROM POWER CABLES OR SERVICE DROPS TO BUILDINGS. THE ANTENNA, SUPPORTING MAST AND/OR TOWER MUST NOT BE CLOSE TO ANY POWER LINES DURING INSTALLATION, REMOVAL OR IN THE EVENT PART OF THE SYSTEM SHOULD ACCIDENTALLY FALL. FOLLOW THE GUIDELINES FOR ANTENNA INSTALLATION RECOMMENDED BY THE U.S. CONSUMER PRODUCT SAFETY COMMISSION AND LISTED IN THE ENCLOSED PAMPHLETS.

Antenna System Planning

Before assembly, take time to review your installation plans for the antenna. Location of the antenna is very important. Surrounding objects such as trees, power lines, buildings, and other antennas will interact with an HF Yagi. To minimize the effects of surrounding objects, mount the antenna as high and in the clear as possible. Metallic guy wire within 30 feet of this antenna, if broken with strain insulators, will improve performance. **YOU MUST INSURE THAT NEITHER PEOPLE OR PETS CAN COME IN CONTACT WITH YOUR ANTENNA WHILE IT IS IN OPERATION. DEADLY VOLTAGES AND CURRENTS MAY EXIST. ALSO, SINCE THE EFFECTS OF EXPOSURE TO RF ARE NOT FULLY UNDERSTOOD, LONG TERM EXPOSURE TO INTENSE RF FIELDS IS NOT RECOMMENDED. THERE IS A WARNING STICKER WHICH MUST BE ATTACHED TO THE BOOM AS SHOWN IN FIGURE A.** Plan your installation carefully. If you use volunteer helpers be sure that they are qualified to assist you. Make certain that everyone involved understands that you are in charge and that they must follow your instructions. If you have any doubts at all, employ a professional antenna installation company to install your antenna.

System Grounding

Direct grounding of the antenna, mast and tower is very important. This serves as protection from lightning strikes and static buildup. A good electrical connection should be made to one or more ground rods directly at the base of the tower or mast using at least #10 AWG ground wire and non-corrosive hardware. For details and safety standards, consult the National Electrical Code. A coaxial lightning arrester should be used. Cushcraft offers several different models such as the LAC series.

Assembly

The assembly procedure for the XM515 consists of assembling the following subassemblies. **1) Boom Assembly. 2) Element Assembly. 3) Element to Boom Assembly. 4) Feed System Assembly. 5) Boom to Mast Assembly.** Assembly of the XM515 will be easiest if the preceding steps are performed in the given order. **Please read through the entire assembly procedure before beginning.**

Verification of Parts

Verify all parts are present by using the XM515 Master Parts List. Check off each part when it is counted. There are extra parts intentionally shipped with this antenna. Place common hardware in temporary containers for ease of assembly. Note all hardware is Stainless Steel.

Part No.	Description	Metric Equivalent	Quantity	Qty Check
MNXM	Matching Network		1	___
X79FS	6" feed strap	15.2 cm	2	___
XM515FL	5/8" x 61-1/4"	1.6 x 155.6 cm	2	___
XM515EA	7/8" x 12" aluminum tube	2.2 x 30.5 cm	3	___
XM515EB	1" x 36" aluminum tube, swedged, slotted one end	2.5 x 91.4 cm	4	___
XM515EC	1" x 36" aluminum tube, swedged, slotted one end	2.5 x 91.4 cm	6	___
X79ED	3/4" x 36" aluminum tube, swedged, slotted one end	1.9 x 91.4 cm	10	___
X79EE	1/2" x 36" aluminum tube, slotted one end	1.3 x 91.4 cm	10	___
X79EF	3/8" x 48" aluminum tube4 x 121.9 cm	10	___
XM515BA	2-1/2" x 60" aluminum tube, 4 holes	6.3 x 152.4 cm	1	___
XM515BB	2-1/2" x 60" aluminum tube, 4 holes	6.3 x 152.4 cm	1	___
XM515BC	2-1/2" x 84" aluminum tube, 10 holes	6.3 x 213.4 cm	1	___
XM515BD	2-3/8" x 12" aluminum tube, 4 holes	6.0 x 30.5 cm	2	___
XM515BE	2-1/2" x 84" aluminum tube, 4 holes	6.3 x 213.4 cm	1	___
XM515BF	2-3/8" x 24" aluminum tube, 8 holes	6.0 x 61 cm	1	___

TA5FA

XM515

Part No.	Description	Metric Equivalent	Quantity	Qty Check
010011	#8-32 Stainless Steel Nut		4	___
010082	1/4-20 x 1" Hex Bolt	0.6 cm - 20 x 2.5 cm	36	___
010084	1/4" Stainless Steel Flat Washer	0.6 cm	67	___
010085	1/4-20 Stainless Steel Nut	0.6 cm	10	___
010207	3/8" Stainless Steel Flat Washer	0.9 cm	4	___
010208	3/8" Stainless Steel Lock Washer	0.9 cm	4	___
010209	3/8" Stainless Steel Nut	0.9 cm	4	___
010231	8-32 x 1-3/4" Stainless Steel machine screw	4.4 cm	4	___
010719	1/4"-20 x 3" Stainless Steel Hex Bolt	7.6 cm	2	___
011941	#8 Stainless Steel Lock Washer		4	___
013209	2-7/8" Center-to-center U-Bolt 4" Long	7.3 cm -10.2 cm Long	2	___
014387	#8-32 Stainless Steel Lock Nut		6	___
014496	1" Cush-a-Clamp	2.5 cm	10	___
014399	1/4" Stainless Steel Lock Nut	0.6 cm	67	___
014588	1/4" x 3-1/2" Stainless Steel Hex Bolt	0.6 x 8.9 cm	9	___
014592	1/4" Stainless Steel Flat Washer 1/8" Thick	0.6 x 0.3 cm	10	___
030407	5/8" Worm Clamp	1.6 cm	10	___
030409	11/16" Worm Clamp	1.7 cm	10	___
030410	1" Worm Clamp	2.5 cm	16	___
050077	3/8" Black Plastic Cap	0.9 cm	10	___
054526	2-1/2" Black Plastic Cap	6.4 cm	2	___
124566	7/8" x 8" Drilled Fiberglass Insulator	2.2 x 20.3 cm	2	___
170035	3-1/2" Formed Aluminum Vee Blocks	8.9 cm	2	___
194542	8" x 8" x 1/4" Aluminum Mounting Plate	20.3 x 20.3 x 0.6 cm	1	___
290326	Danger Label		1	___
323832	Feed Line Insulator		1	___
324506	8" x 5-1/4" x 3/16" Drilled Extruded Aluminum Bracket	20.3 x 13.3 x 0.5 cm	2	___
324509	4" x 5-1/4" x 3/16" Drilled Extruded Aluminum Bracket	10.2 x 13.3 x 0.5 cm	10	___

TA5FA

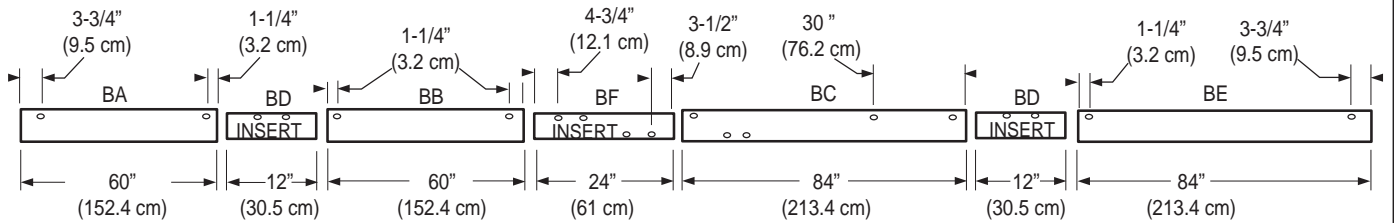
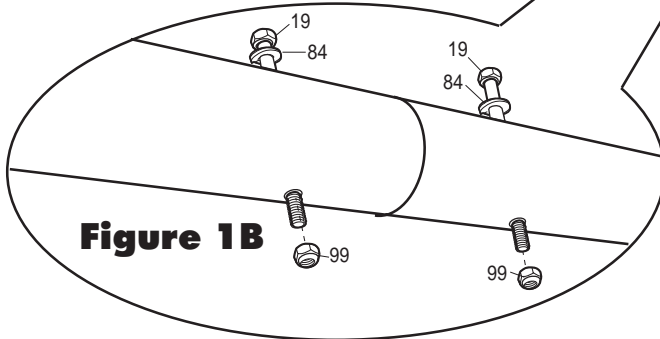
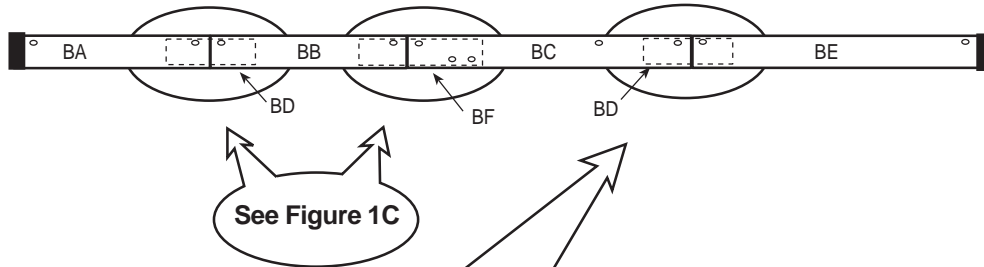

Figure 1A



1-Boom Assembly

Lay out boom sections as shown in Figure 1A. Make sure tube ends are free of debris to allow the inserts BD and BF to slide more easily. Applying penetrating oil to the inserts will also be helpful. Secure the BC/BE connection as shown in Figure 1B.

The other boom connections are made using the element mounting hardware as shown in Figure 1C. When installing the 1" hex bolt (82), lock washer (84), and nut (85) on the element bracket, tighten the nut completely before attaching to the second bracket. After the boom is assembled attach the remaining three element mount brackets shown in Figure 1D.

ID	Part #		Description	Dimensions	Qty
BA	XM515BA		Aluminum Tube	2-1/2" x 60" (6.3 x 152.4 cm)	1
BB	XM515BB		Aluminum Tube	2-1/2" x 60" (6.3 x 152.4 cm)	1
BC	XM515BC		Aluminum Tube	2-1/2" x 84" (6.3 x 213.4 cm)	1
BD	XM515BD		Aluminum Tube	2-3/8" x 12" (6.0 x 30.5 cm)	2
BE	XM515BE		Aluminum Tube	2-1/2" x 84" (6.3 x 213.4 cm)	1
BF	XM515BF		Aluminum Tube	2-3/8" x 24" (6.0 x 61 cm)	1
19	010719		SS Hex Bolt	1/4-20 x 3" (7.6)	2
26	054526		Black Plastic Cap	2-1/2" (6.3 cm)	2
84	010084		SS Lock Washer	1/4"	2
99	014399		SS Lock Nut	1/4-20	2

Figure 1C

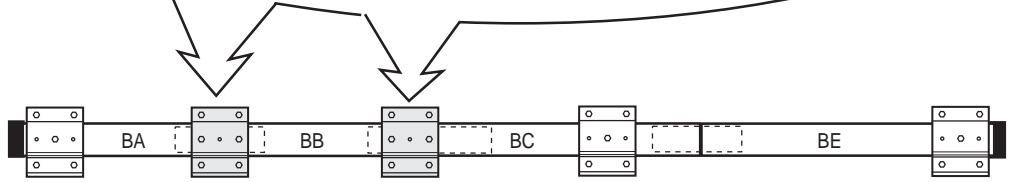
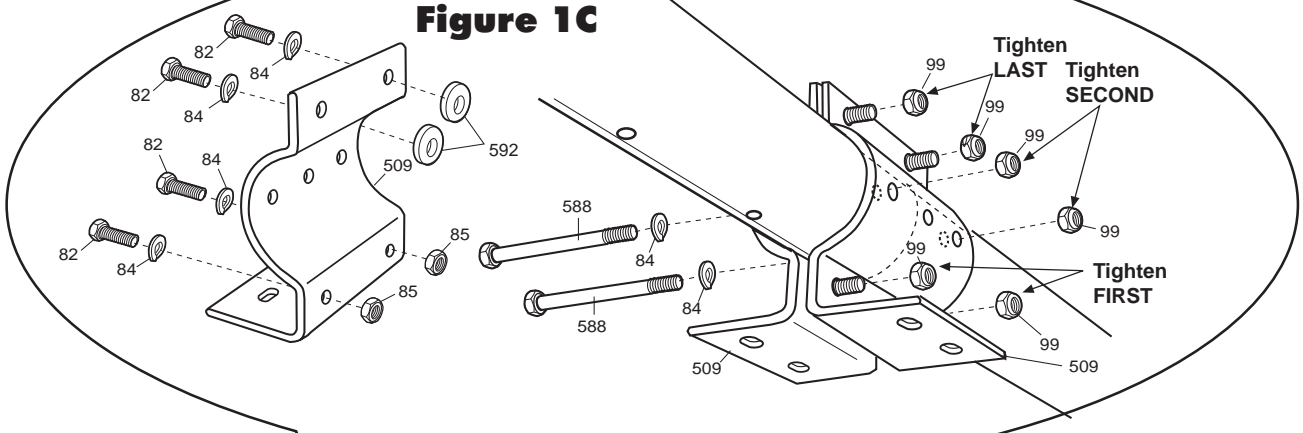
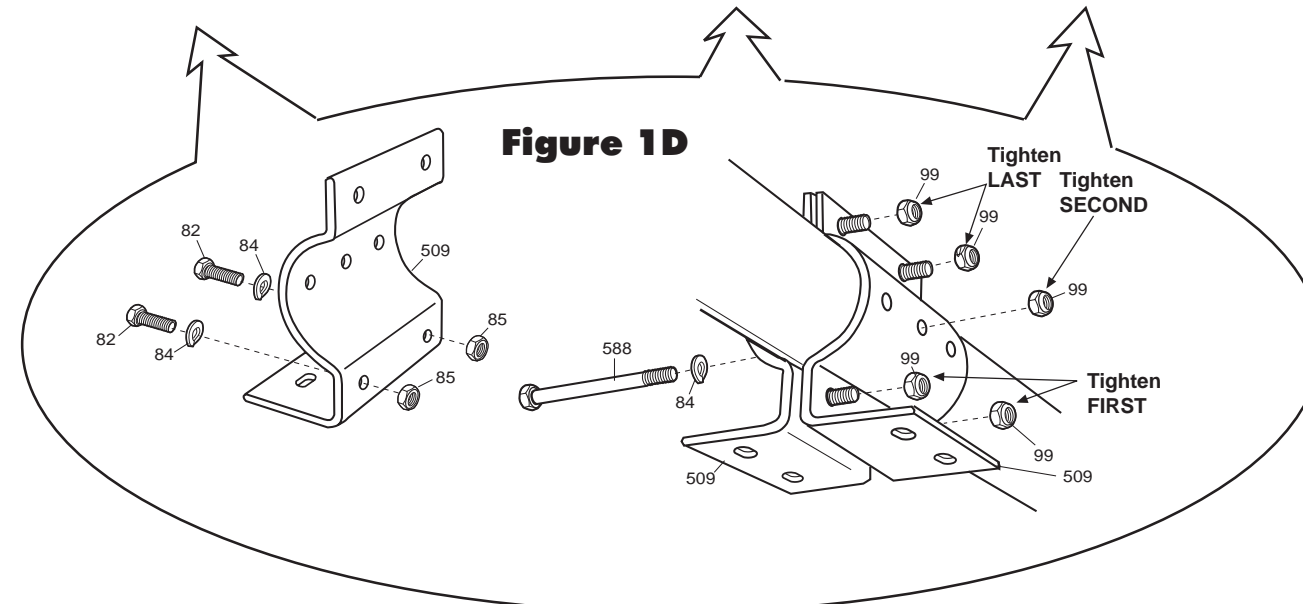









Figure 1D



ID	Part #		Description	Dimensions	Qty
82	010082		Hex Bolt	1/4-20 x 1" (.6 x 2.5 cm)	20
84	010084		SS Lock Washer (.6 cm)	1/4"	27
85	010085		SS Nut (.6 cm)	1/4-20	10
99	014399		SS Lock Nut (.6 cm)	1/4" (.6 cm)	27

ID	Part #		Description	Dimensions	Qty
509	324509		Aluminum Bracket	4" x 5-1/4 x 3/16" (10.2 x 13.3 x .5 cm)	10
588	014588		SS Hex Bolt	1/4" x 3-1/2" (.6 x 10.2 cm)	7
592	014592		SS Flat Washer (.6 x .3 cm)	1/4" (1/8" thick) (.6 x .3 cm)	10

2 - Element Assembly

Figures 2A and 2B show the steps required for element assembly. Slide EB sections over fiberglass insulator (566) until #8 screw holes line up (Figure 2B) . Insert screws (231) through holes and secure with lock washer (41) and nut (11). Pay close attention to all dimensions shown.

Figure 1A

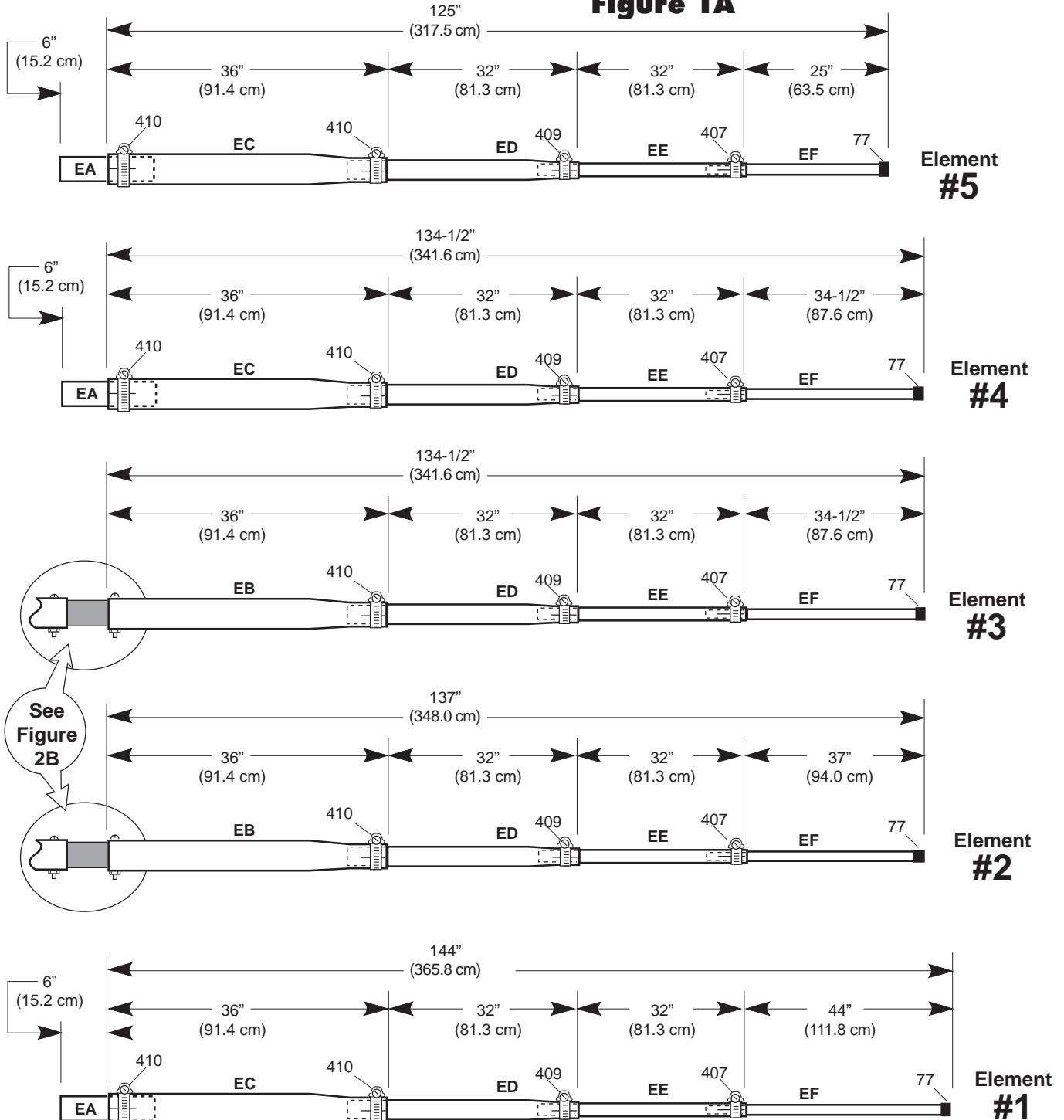

TA5FA

Element Assembly Continued

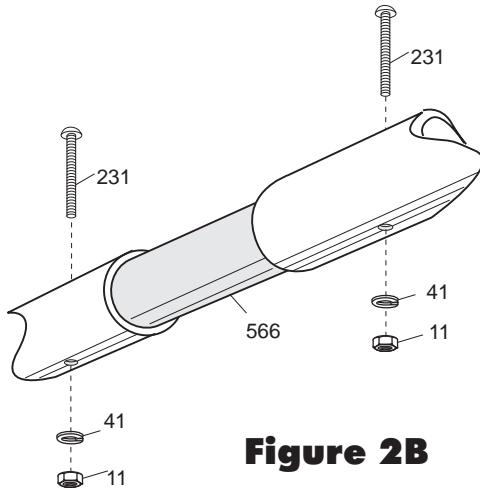

Figure 2B

ID	Part #		Description	Dimensions	Qty
11	010011		SS Nut	#8-32	4
41	011941		SS Lock Washer	#8	4
77	050077		Black Plastic Cap	3/8" (0.9 cm)	10
231	010231		SS Machine Screw	#8-32 x 1-3/4" (4.4 cm)	4
407	030407		Worm Clamp	5/8" (1.6 cm)	10
409	030409		Worm Clamp	11/16" (1.7 cm)	10
410	030410		Worm Clamp	1" (2.5 cm)	16
566	124566		Fiberglass Insulator	7/8" x 8" (2.2 x 20.3 cm)	2
EA	XM515EA		Aluminum Tube	7/8" x 12" (2.2 x 30.5 cm)	3
EB	XM515EB		Aluminum Tube	1" x 36" (2.5 x 91.4)	4
EC	XM515EC		Aluminum Tube	1" x 36" (2.5 x 91.4 cm)	6
ED	X79ED		Aluminum Tube	3/4" x 36" (1.9 x 91.4 cm)	10
EE	X79EE		Aluminum Tube	1/2" x 36" (1.3 x 91.4 cm)	10
EF	X79EF		Aluminum Tube	3/8" x 48" (.4 x 121.9 cm)	10

3 - Element to Boom Assembly

Figure 3A

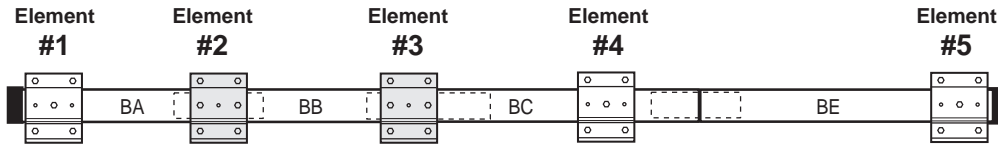

Figure 3B

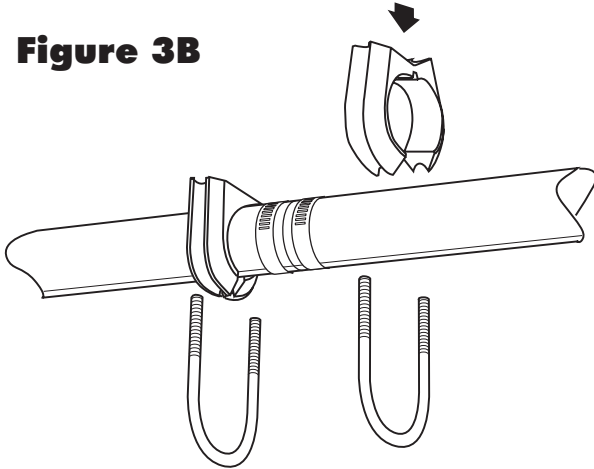

Figure 3C

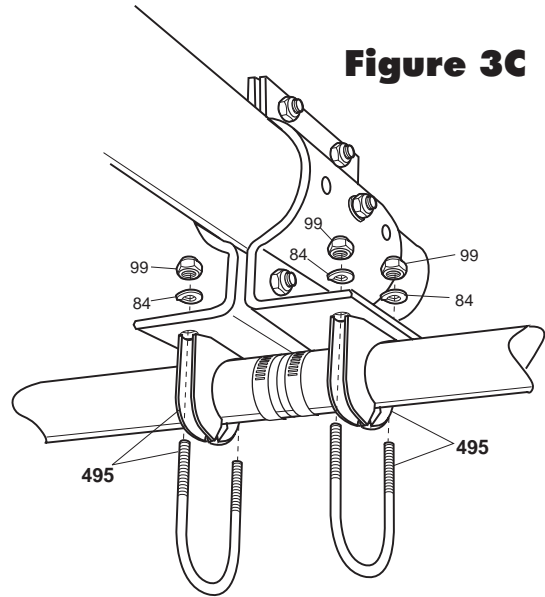
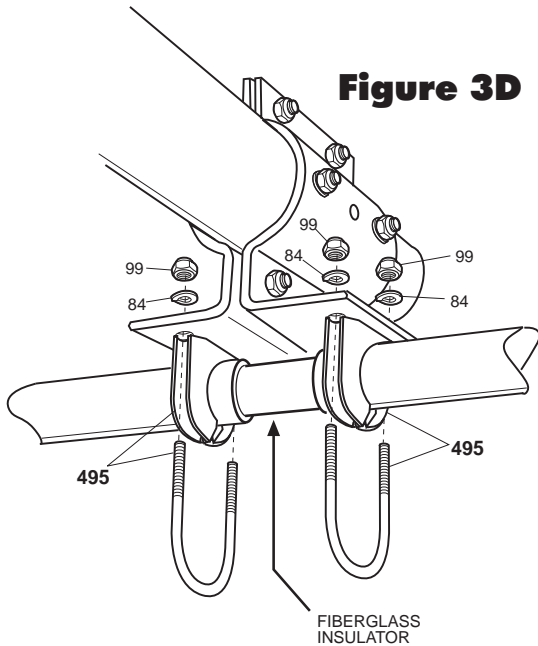





Figure 3D



Elements can be attached to the boom when the antenna is on the ground or when the antenna is being installed on a tower. Refer to Figure 3A for element locations. Identify the hardware required to secure the elements. Attach Cush-a-Clamps on each element according to Figure 3B. When securing element to the boom brackets, tighten each clamp until the element tubing can no longer rotate inside the Cush-A-Clamp. The lock washers under the nuts securing the Cush-A-Clamps should be tightened until they are flat against the mounting bracket. Figure 3C illustrates the mounting of elements 1, 4 and 5. Figure 3D shows elements 2 and 3.

ID	Part #		Description	Dimensions	Qty
84	010084		SS Lock Washer	1/4" (.6 cm)	20
99	014399		SS Lock Nut	1/4" (.6 cm)	20
495	014495		Cush-a-Clamp® (2.2 cm)	7/8"	10

TA5FA

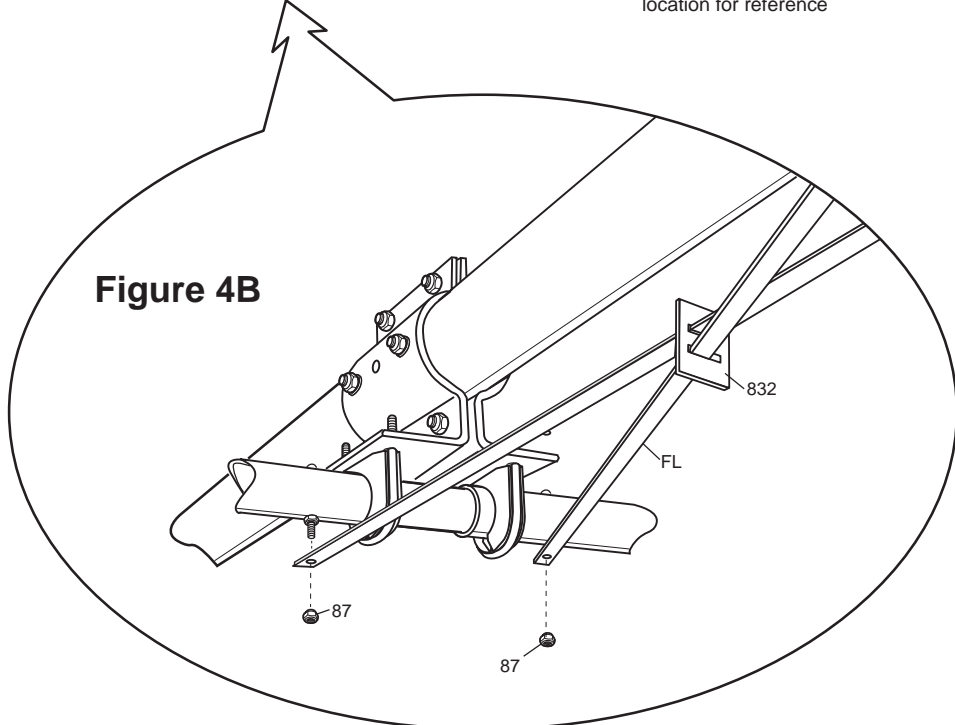
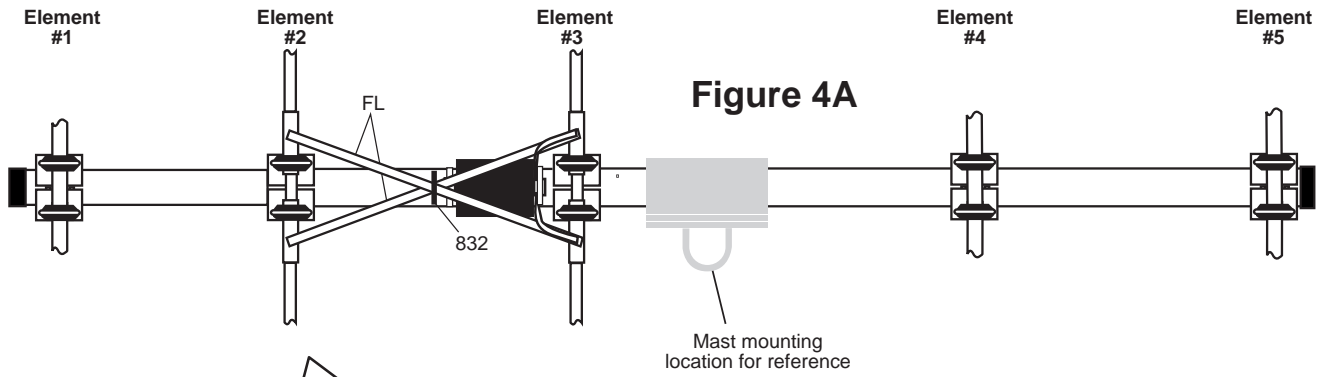





4-Feed System Assembly

The feed system consists of 2 sub-assemblies. They are the feed-straps (Figure 4B) and the matching network (Figure 4C).

Referring to Figure 4B, insert the feedline straps (FL) into the slots on the strap insulator (832) . Attach the feedline straps to element #2 and secure with nuts (87).

ID	Part #		Description	Dimensions	Qty
87	014387		SS Lock Nut	#8-32	2
832	323832		Strap Insulator	2" x 1-1/2" x 1/8" (5.1 x 3.8 x .3 cm)	1
FL	XM515FL		Aluminum Strap	5/8" x 61-1/4" (1.6 x 155.6 c m)	2

ID	Part #		Description	Dimensions	Qty
81	032881		Worm Clamp	2-1/16" x 3" (5.2 x 7.6 cm)	2
87	014387		SS Lock Nut	#8-32	2
MN	MNXM		Matching Network		1
FS	X79FS		Copper Braid	1/2" x 6" (1.2 x 15 cm)	2

Feed System Assembly Continued

Reference Figure 4C for matching network mounting. Attach matching network (MN) to boom with two worm clamps (81). Connect copper braid feed straps (FS) from matching network terminals to aluminum straps (FL) as shown. Form drip loops in the copper feed straps (FS) and position them as shown.

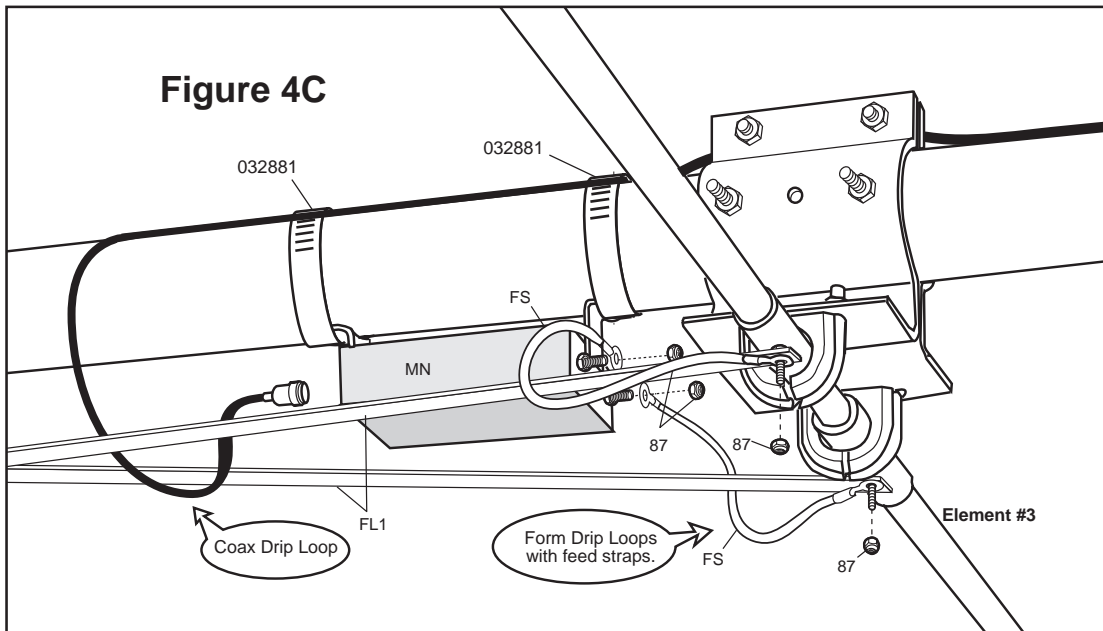

5- Boom to Mast Assembly

The XM515 boom to mast clamp is designed to be mounted on the tower/mast so the built in boom shelf feature can be utilized. Following this suggestion, if possible, will simplify antenna installation

Form the boom shelf by attaching the lower boom bracket (506) to the mast plate (542) using hardware shown (Figure 5A). Attach mast plate (542) to mast using U-bolts (3209) and V-blocks (35).

Place the boom on the boom shelf during installation. Loosely attach the top boom bracket (506) to the mast-plate (542) and to the lower boom bracket (506) as shown in Figure 5B. This allows the boom to be moved back and forth for tower top element mounting.

When all elements are securely mounted to the boom and the feed system is in place, line up the 2 holes in the top of the upper boom bracket (506) holes with the corresponding 2 holes in boom section BC. Insert bolts (588) and tighten in place. Next, tighten the 8 bolts, securing the upper and lower boom brackets. Tighten the 4 bolts connecting the upper boom bracket to the mast plate.

Attach good quality coax with a PL-259 connector to the XM515 matching network. Form a drip-loop with the coax and secure the coax to the boom. Insure PL-259 connector is waterproofed with a good quality sealant after it is attached to the matching network.

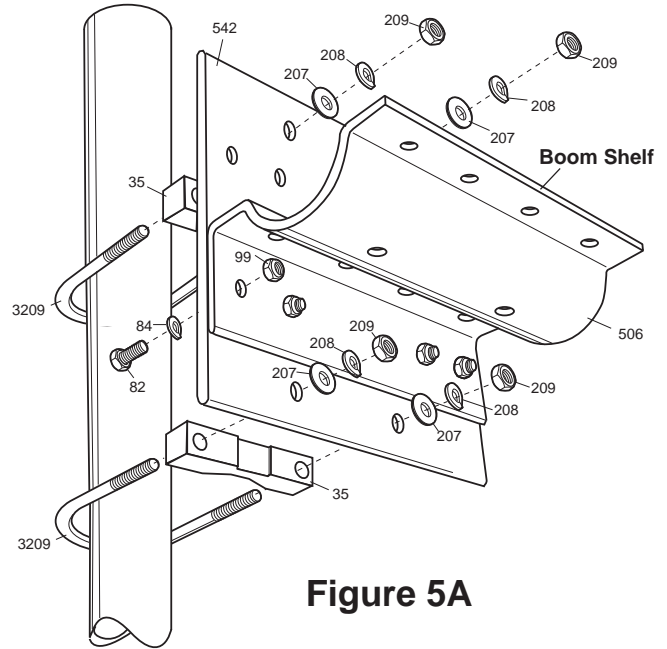

Figure 5A

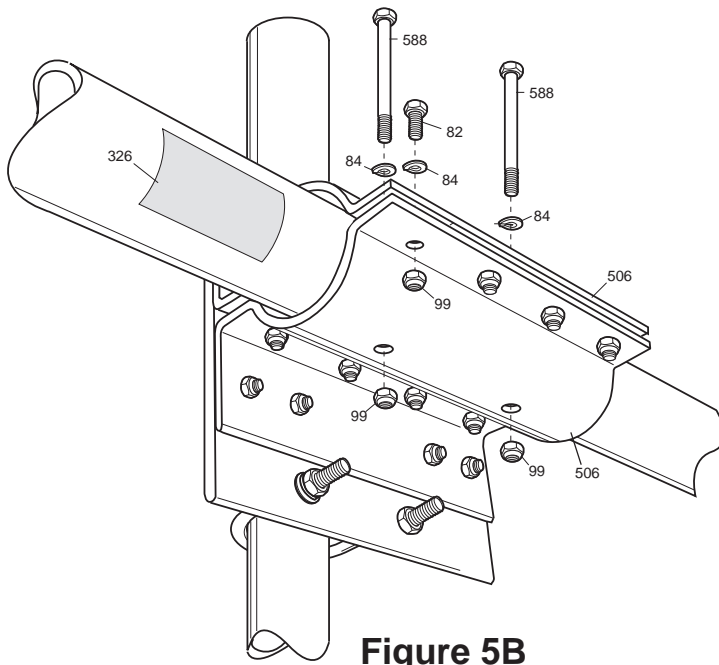

Figure 5B

ID	Part #		Description	Dimensions	Qty
35	170035		Aluminum V-Block	3-1/2" (8.9 cm)	2
82	010082		Hex Bolt	1/4-20 x 1" (2.5 cm)	16
84	010084		SS Lock Washer	1/4" (0.6 cm)	18
99	014399		SS Lock Nut	1/4" (.6 cm)	18
207	010207		SS Flat Washer	3/8" (.95 cm)	4
208	010208		SS Lock Washer	3/8" (.95 cm)	4
209	010209		SS Nut	3/8" (.95 cm)	4
326	290326		Danger Label		1
506	324506		Aluminum Bracket	8" x 5-1/4" x 3/16" (20.3 x 13.3 x .5 cm)	2
542	194542		Alu Mounting Plate	8" x 8" x 1/4" (20.3 x 20.3 x .6 cm)	1
588	014588		SS Hex Bolt	1/4" x 3-1/2" (.6 x 8.9 cm)	2
3209	013209		U-Bolt	2-7/8" (7.3 cm)	2

TA5FA

SPECIFICATIONS

Frequency Coverage (Meters)	15	Boom Length, ft (m)	24 (7.3)
Total number of Elements	5	Boom Diameter, in (cm)	2.5 (6.3)
Free Space Gain (dBi)	9.3	Maximum Mast Diameter OD, in (cm)	2.5 (6.3)
Maximum Front to Back Ratio (dB)	25	Maximum Wind Survival, mph (kph)	>100 (>161)
VSWR Minimum	1.1	Maximum Wind Surface Area, ft ² (m ²)	4.5 (.41)
VSWR 1.5:1 Bandwidth (KHz)	450	Wind Load @ 80 mph (129 kph), lb (kg)	115 (52.3)
Longest Element, ft (m)	24 (7.3)	Maximum Power Handling (KW)	2
Turning Radius, ft (m)	16.3 (5.0)	Weight, lb. (kg)	47 (21.1)
		Design Safety Factor	1.25

The Electrical Specifications for all Cushcraft Amateur Antennas are derived from numerical analysis and measured data taken on our test range. Performance may vary due to the random variables associated with a specific application or installation.

Limited Warranty

Cushcraft Corporation, 48 Perimeter Road, Manchester, New Hampshire 03103, warrants to the original consumer purchaser for one year from date of purchase that each Cushcraft antenna is free of defects in material or workmanship. If, in the judgement of Cushcraft, any such antenna is defective, then Cushcraft will, at its option, repair or replace the antenna at its expense within thirty days of the date the antenna is returned (at purchaser's expense) to Cushcraft or one of its authorized representatives. This warranty is in lieu of all other expressed warranties. Any implied warranty is limited in duration to one year. Cushcraft Corporation shall not be liable for any incidental or consequential damages which may result from a defect. Some states do not allow a limitation on how long an implied warranty lasts or exclusions or limitations of incidental or consequential damages, so the above limitation and exclusion may not apply to you. This warranty gives you specific legal rights, and you may also have other rights which vary from state to state. This warranty does not extend to any products which have been subject to misuse, neglect, accident or improper installation. Any repairs or alterations outside of the Cushcraft factory will nullify this warranty.



CUSHCRAFT
COMMUNICATIONS ANTENNAS