

# ASSEMBLY AND INSTALLATION

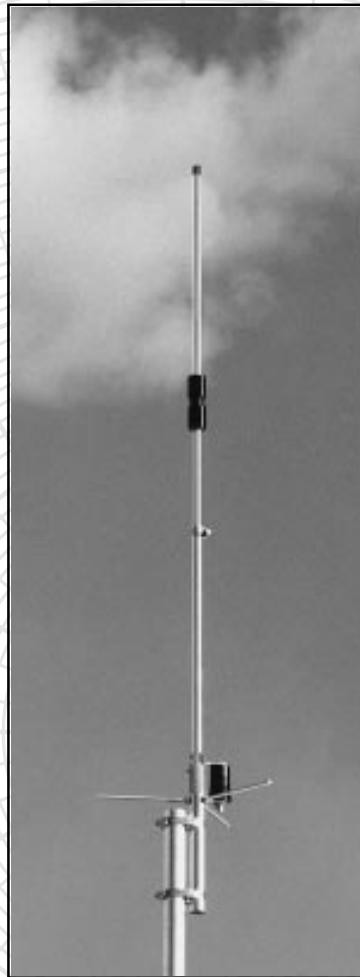

# AR-270

DUAL BAND RINGO  
2 METER / 70 CM



TA5FA  
951375 (2/95)

**WARNING:** THIS ANTENNA IS AN ELECTRICAL CONDUCTOR. CONTACT WITH POWER LINES CAN RESULT IN DEATH, OR SERIOUS INJURY. DO NOT INSTALL THIS ANTENNA WHERE THERE IS ANY POSSIBILITY OF CONTACT WITH OR HIGH VOLTAGE ARC-OVER FROM POWER CABLES OR SERVICE DROPS TO BUILDINGS. THE ANTENNA SHOULD NOT BE LOCATED WHERE PEOPLE OR PETS CAN COME IN CONTACT WITH IT. THE ANTENNA, SUPPORTING MAST AND/OR TOWER MUST NOT BE CLOSE TO ANY POWER LINES DURING INSTALLATION, REMOVAL OR IN THE EVENT PART OF THE SYSTEM SHOULD ACCIDENTALLY FALL. APPLY THE ELECTRICAL SHOCK WARNING LABEL (326) TO A PROMINENT LOCATION ON THE ANTENNA BASE AS SHOWN ON FIGURE 1. FOLLOW THE GUIDELINES FOR ANTENNA INSTALLATIONS RECOMMENDED BY THE U.S. CONSUMER PRODUCT SAFETY COMMISSION AND LISTED IN THE ENCLOSED PAMPHLET.

Your Cushcraft dual band vertical is designed to give top performance and trouble free service. This antenna will perform as specified if the suggestions are followed and care is used in assembly and installation.

## LOCATION

Location of the antenna is very important. Surrounding objects such as trees, power lines, other antennas, etc. will seriously reduce efficiency. To minimize the effects of surrounding objects, mount the antenna as high and in the clear as possible. If metal guy wires are used, they should be broken with strain insulators.

Plan your installation carefully. If you use volunteer helpers be sure that they are qualified to assist you. Make certain that everyone involved understands that you are the boss and that they must follow your instructions. If you have any doubts at all, employ a professional antenna installation company to install your antenna.

## MOUNTING

The AR-270 will take up to a 2" (5.1 cm) OD mast. For all installations the antenna must be mounted on the top 6 inches (15 cm) of a mast. It should be mounted above horizontally polarized beam antennas. If you side mount this antenna on a tower it will require a short mast, secured at two points. The mast should be kept at least 1/4 wavelength or 20 inches (50 cm) away from the tower.

## SYSTEM GROUNDING

Direct grounding of the antenna, mast and tower is very important. This serves as protection from lightning strikes and static buildup, and from high voltage which is present in the radio equipment connected to the antenna. A good electrical connection should be made to one or more ground rods (or other extensive ground system) directly at the base of the tower or mast, using at least #10AWG ground wire and non-corrosive hardware. For details and safety standards, consult the National Electrical Code. You should also use a coaxial lightning arrester. Cushcraft offers several different models, such as LAC-1, LAC-2 and the LAC-4 series.

## ASSEMBLY

Assemble your antenna by following the directions and illustrations in steps #1 through #3. After the antenna is completely assembled, verify the dimensions for accuracy. Return to the section below for final tuning.

## TUNING PROCEDURE

With the dimensions shown in figure 2, the antenna should not require any tuning. If you decide to minimize the VSWR at your favorite operating frequency, insert a good quality 50 Ohm standing wave bridge as close to the antenna as possible. First check the forward power and then the reverse power. Keep away from the antenna when making these tests.

If the VSWR is higher than desired, loosen clamp #407 on the lower section and increase or decrease the length of dimension "A" by 1/4" (.64 cm). If the VSWR increases, reverse direction. If the VSWR decreased, continue in this direction until there is little or no reflected power at the bridge. Remember that both frequency bands will be affected by this adjustment so some compromise may be required.

A VSWR of 1.5:1 meets commercial standards. Even if the VSWR is less than 2:1 this antenna will still radiate an optimum signal and meet all specifications.

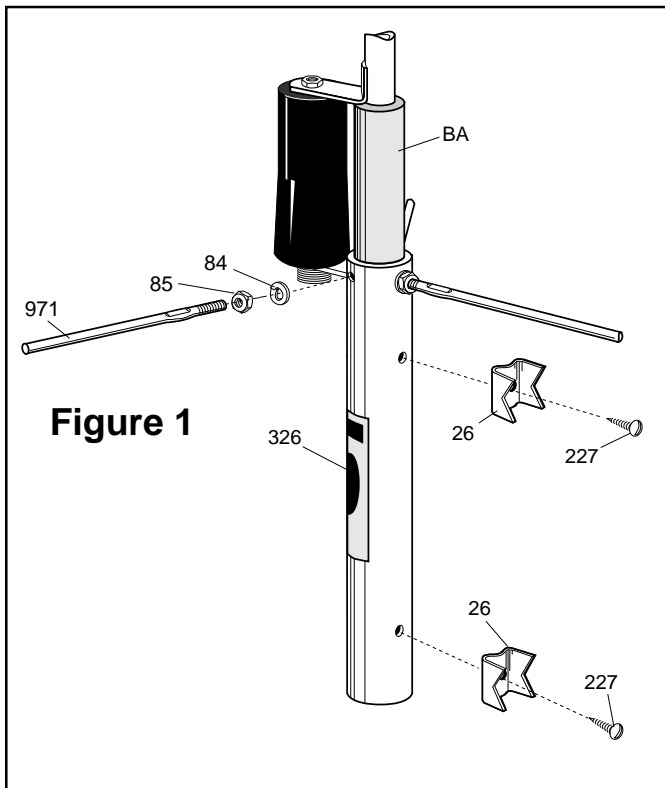











Figure 1

### #1 - ANTENNA ASSEMBLY

Thread the three ground radials (971) into the base section using the washers (84) and nuts (85) provided (figure 1). Insert all three radials (971) an equal amount until they touch each other inside the antenna base assembly (BA). Be very careful not to overtighten the radial rods or their clamping nuts (85). Over tightening may cause permanent unwarranted damage. Next place the worm clamp (407) on the top of the base section. Insert TA into BA and set to dimension A (figure 2) and tighten the clamp. Affix danger label (326) to base (figure 1). Attach aluminum brackets (26) with self tapping screws (227) as shown.

KEY	P/N	DISPLAY	DESC	SIZE	QTY
26	190026		ALUMINUM BRACKET		2
53	050053		PLASTIC CAP	1/2" (1.27 cm)	1
84	010084		LOCK WASHER	1/4" (.6 cm)	3
85	010085		HEX NUT	1/4" (.6 cm)	3
227	010227		SELF TAPPING SCREW	#8 X 1/2" (.95 cm)	2
326	290326		DANGER LABEL		1
407	030407		WORM CLAMP	5/8" (1.6 cm)	1
BA			BASE ASSEMBLY		1
TA			TOP ASSEMBLY		1
971	082971		RADIAL RODS	6-3/4" (17.1 cm)	3

#### TUNING CHART

FREQUENCY RANGE	A
144-146 MHz & 430-440 MHz	21" (53.34 cm)
145-148 MHz & 438-450 MHz	20-1/4" (51.44 cm)

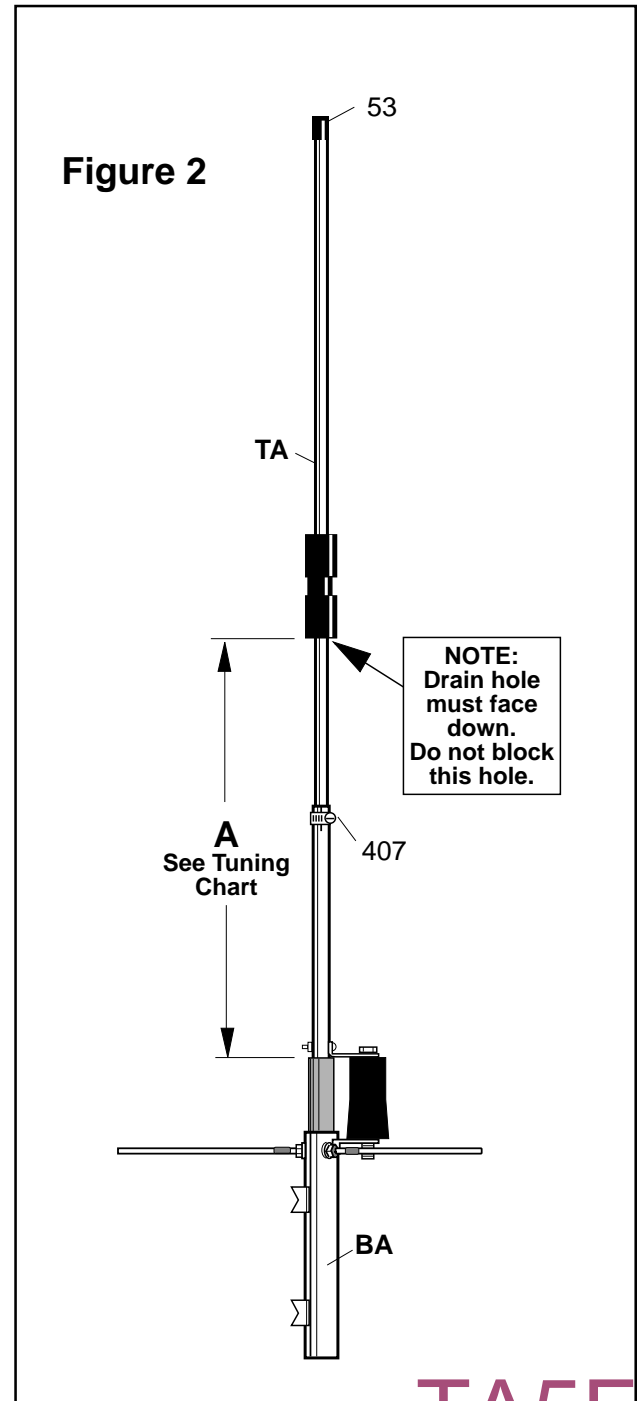

Figure 2

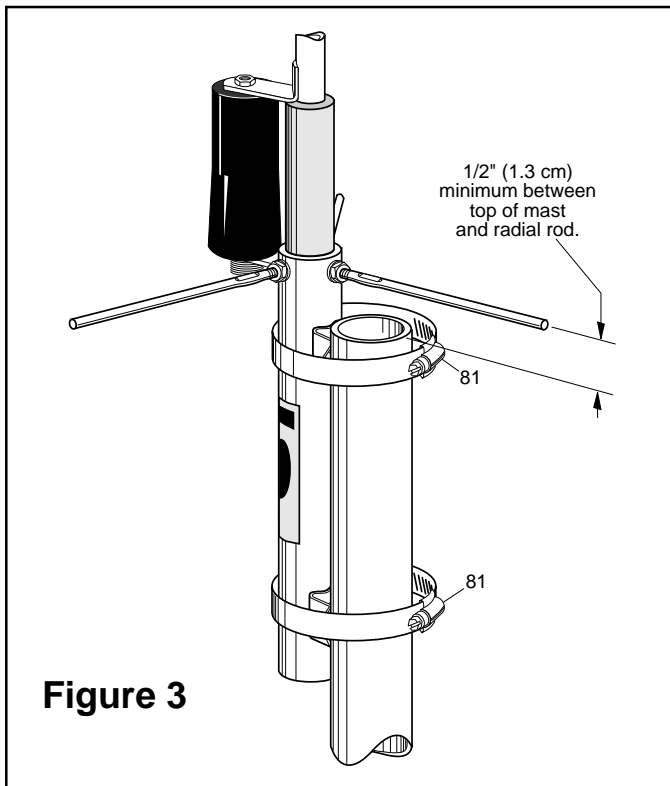





Figure 3

### #2 - MASTING

Attach the AR-270 to the top of your mast which can be 1-1/4" to 2" (3.2-5.1 cm) outside diameter. Using the large worm clamps (81) secure the antenna to the top of the mast (figure 3). The radials should be at least 1/2 inch (1.3 cm) above the top of the mast.

KEY	P/N	DISPLAY	DESC	SIZE	QTY
81	032881		WORM CLAMP	3" (7.6 cm)	2
115	050115		CONNECTOR BOOT		1
116	240116		SILICONE PACKAGE		1

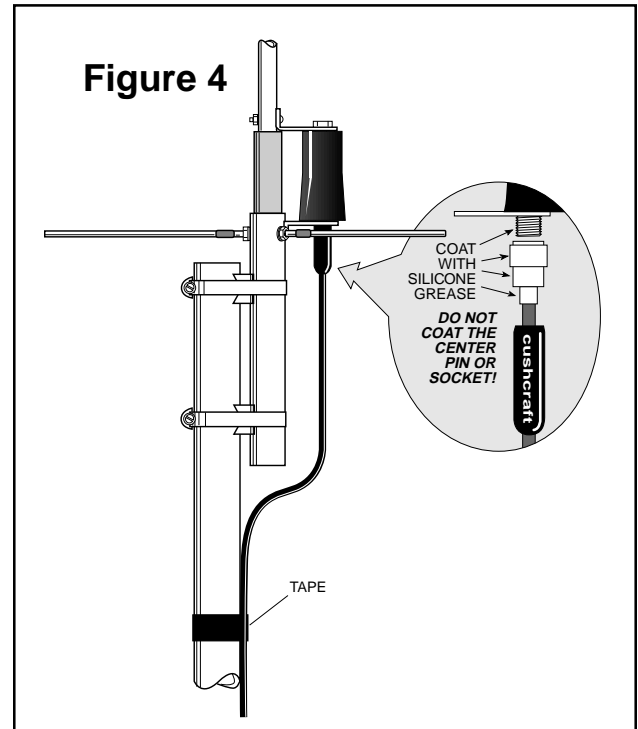

Figure 4

### #3 - FEEDLINE

The AR-270 is designed for use with 50 Ohm coaxial cable terminated with a PL-259 connector. Any length of feedline can be used with your AR-270. The shortest length of cable will have the least loss. A connector boot is included for use with your new antenna. Slide the boot over the cable before attaching your PL-259 (figure 4). Spread silicone grease on the outer threads of the connector located on the base matching assembly and on the PL-259 connector. DO NOT COAT THE CENTER PIN OF THE PL-259! Attach the connector to the base matching network. Apply the remaining silicone to the outside of the connector. Slip the vinyl boot over the connector and against the connector bracket for a weathertight connection. If you plan to install the antenna in a salty or corrosive environment, you may want to consider coating it with a clear marine varnish or equivalent, after it is assembled.

### MASTER PARTS LIST

26	190026	Aluminum bracket	2
53	050053	Black plastic cap	1
81	032881	2-1/16-3" worm clamp	2
84	010084	1/4" (.6 cm) lock washer	3
85	010085	1/4" (.6 cm) hex nut	3
115	050115	Connector boot	1
116	240116	Silicone package	1
227	010227	#8 x 1/2" (.95 cm) self tapping screw	2
326	290326	Danger label	1
407	030407	7/32-5/8" worm clamp	1
971	082971	Radial rod	3
BA		Base assembly	1
TA		Top assembly	1

## SPECIFICATIONS

Model	AR-270	
Frequency, MHz	144-148	430-450
VSWR 1.2:1 Typical		
2:1 Bandwidth in MHz	>4	>15
Gain, dB	3.7	5.5
Power Rating, Watts FM	250	250
Horizontal Radiation		
Pattern, Degrees	360	360
Height, ft (m)	4.04 (1.23)	
Mast Size Range, in (cm)	1.25-2.0 (3.2-5.1)	
Radial Length, in (cm)	6.75 (17.1)	
Wind Load, ft <sup>2</sup> (m <sup>2</sup> )	0.29 (0.03)	
Weight, lb (kg)	2.0 (0.9)	

### LIMITED WARRANTY

Cushcraft Corporation, P.O. Box 4680, Manchester, New Hampshire 03108, warrants to the original consumer purchaser for one year from date of purchase that each Cushcraft antenna is free of defects in material or workmanship. If, in the judgement of Cushcraft, any such antenna is defective, then Cushcraft Corporation will, at its option, repair or replace the antenna at its expense within thirty days of the date the antenna is returned (at purchasers expense) to Cushcraft or one of its authorized representatives. This warranty is in lieu of all other expressed warranties, any implied warranty is limited in duration to one year. Cushcraft Corporation shall not be liable for any incidental or consequential damages which may result from a defect. Some states do not allow limitations on how long an implied warranty lasts or exclusions or limitations of incidental or consequential damages, so the above limitation and exclusion may not apply to you. This warranty gives you specific legal rights, and you may also have other rights which vary from state to state. This warranty does not extend to any products which have been subject to misuse, neglect, accident or improper installation. Any repairs or alterations outside of the Cushcraft factory will nullify this warranty.



48 PERIMETER ROAD, MANCHESTER, NH 03108 USA  
603-627-7877 • TELEX: 4949472 • FAX: 603-627-1764

SPECIFICATIONS SUBJECT TO CHANGE WITHOUT NOTICE

TA5FA