

# ASSEMBLY AND INSTALLATION INSTRUCTIONS

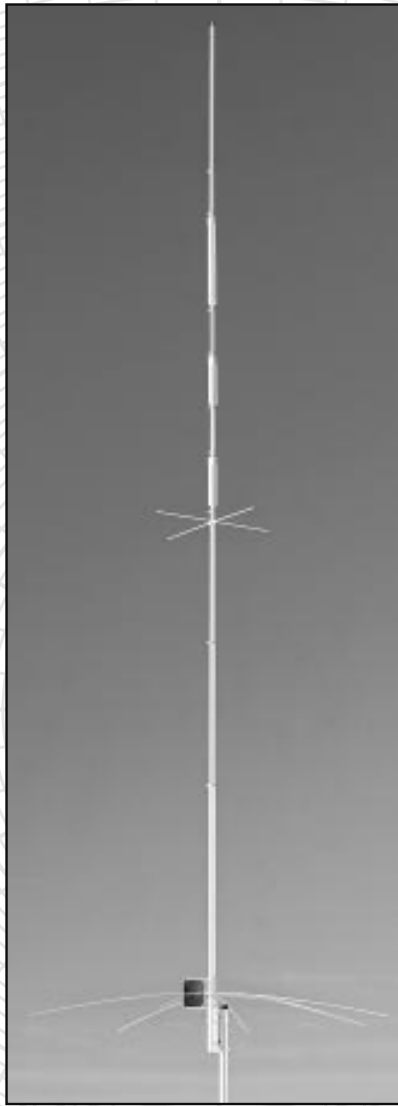

# R7000

10, 12, 15, 17, 20, 30, 40 Meters



TA5FA  
951465 (10/96)

## WARNING

THIS ANTENNA IS AN ELECTRICAL CONDUCTOR. CONTACT WITH POWER LINES CAN RESULT IN DEATH, OR SERIOUS INJURY. DO NOT INSTALL THIS ANTENNA WHERE THERE IS ANY POSSIBILITY OF CONTACT WITH HIGH VOLTAGE OR ARC-OVER FROM POWER CABLES OR SERVICE DROPS TO BUILDINGS. THE ANTENNA, SUPPORTING MAST AND/OR TOWER MUST NOT BE CLOSE TO ANY POWER LINES DURING INSTALLATION, REMOVAL OR IN THE EVENT PART OF THE SYSTEM SHOULD ACCIDENTALLY FALL. FOLLOW THE GUIDELINES FOR ANTENNA INSTALLATIONS RECOMMENDED BY THE U.S. CONSUMER PRODUCT SAFETY COMMISSION AND LISTED IN THE ENCLOSED PAMPHLET.

Your Cushcraft R7000 vertical antenna is designed and manufactured to give trouble free service. This antenna will perform as specified if the instructions and suggestions in this manual are followed and care is used in the assembly and installation. When checking the components received in your antenna package use the parts listed beside each diagram. There is a master parts list on page 2. If you are unable to locate any tube or component, check the inside of all tubing. **IMPORTANT:** Save the weight label from the outside of the carton. Each antenna is weighed at the factory to verify the parts count. If you claim a missing part, you will be asked for the weight verification label.

## PLANNING

Plan your installation carefully. If you use volunteer helpers be sure that they are qualified to assist you. Make certain that everyone involved understands that you are the boss and that they must follow your instructions. If you have any doubts at all, employ a professional antenna installation company to install your antenna.

## LOCATION

Although the R7000 will operate in almost any location, it will perform best if it is mounted vertically and located in the clear away from surrounding objects such as buildings, trees, power lines, towers, guy wires, antennas and metallic objects. The R7000 should not be attached to a ground radial system. Failure to heed these points will possibly degrade performance, detune the antenna and increase VSWR.

**EXTREME CARE MUST BE USED FOR YOUR SAFETY. YOU MUST INSURE THAT WHILE THE R7000 IS IN OPERATION NEITHER PEOPLE OR PETS CAN COME IN CONTACT WITH ANY PORTION OF YOUR ANTENNA INCLUDING THE COUNTERPOISE RODS. DEADLY VOLTAGES AND CURRENTS MAY EXIST. ALSO, SINCE THE EFFECTS OF EXPOSURE TO RF ARE NOT FULLY UNDERSTOOD, LONG TERM EXPOSURE TO INTENSE RF FIELDS IS NOT RECOMMENDED. THERE ARE SEVEN WARNING STICKERS WHICH MUST BE ATTACHED TO THE ENDS OF THE COUNTERPOISE RODS AS SHOWN IN FIGURE 2.**

## MOUNTING

Your mast should be rigid and pointing straight up. Always use a mast at least 1-3/4 inches (4.4 cm) but not larger than 2-1/8 inches (5.4 cm) in diameter. If you guy the mast, use non-conducting guy wires.

## SYSTEM GROUNDING

Direct grounding of the antenna mast is very important. This serves as protection from lightning strikes and static buildup, and from high voltages which may be present in the equipment attached to the antenna. A good electrical connection should be made to one or more ground rods directly at the base of the antenna or mast using a least #10 AWG ground wire and non-corrosive hardware. For details and safety standards, consult the National Electrical Code. You should also use a coaxial lightning arrestor. Cushcraft offers several different models, such as the LAC-1, LAC-2 or the LAC-4 series.

## ASSEMBLY

Assemble your R7000 by following steps 1 through 5. After assembling the antenna, verify all dimensions in figure F for accuracy. Then return to the adjustment section below for final tuning.

## ADJUSTMENT

The dimensions in figure F normally allow proper operation on all the bands. However, some variations may occur from one location to another. Adjustments must be made from the bottom of the antenna to the top. Adjusting the antenna from top to bottom will not work. This is because the settings at the top are severely affected by the adjustments at the bottom.

We suggest measuring the VSWR of your antenna by using the SWR meter in your transceiver. If your transceiver does not have one, use a good quality VSWR bridge for this application. We will begin with 10 meters since this is at the bottom of the antenna. Set your transceiver at your favorite frequency on 10 meters. Key the rig and check your VSWR. The R7000 is extremely broadbanded on 10 meters and seldom needs adjustment. If the VSWR is low enough (below 1.5:1) then move on to the 12 meter band. If the 10 meter VSWR is not low enough, adjust the antenna as follows: Check several frequencies on 10 meters to find the frequency of lowest VSWR. If the frequency of lowest VSWR is above your favorite frequency, lengthen dimension A (figure F) by 1 inch (2.5 cm). This should lower the frequency of lowest VSWR by 50 to 100 KHz. If the frequency of lowest VSWR is below your desired frequency, shorten dimension A (figure F) by 1 inch (2.5 cm). Check your desired 10 meter operating frequency again to see if the VSWR is less than 1.5:1. Repeat this procedure until the VSWR at your desired frequency is low enough. Adjusting Dimension A is also used to move the resonant frequency of 12m.

Continue this procedure by selecting your desired frequency on 15 meters and checking the VSWR there. Dimension B (figure F) should be used to adjust the VSWR on 15 meters. *Remember to shorten this dimension to raise the frequency or lengthen it to lower the frequency.*

The balance of the antenna should be adjusted in a like manner. The dimensions and the bands that they effect are shown in figure F. On 10 through 30 meters 1 inch (2.5 cm) of change in length will change the operating frequency by 50 to 100 KHz. On 30 and 40 meters the change will be 15 to 25 KHz per inch (5 to 10 KHz/cm). When the antenna is completely adjusted, check all fasteners to be sure they are tight. Improving VSWR's that are less than 2:1 will not noticeably improve station performance.

# TA5FA

# R7000

## INSTALLATION

Following the guidelines in the location and adjustment sections above, place the antenna on its mast in its final operating location. If you plan to install the antenna in a salty or corrosive environment, you may want to consider coating it with a clear marine varnish or equivalent *after final assembly and adjustment has been completed*. Now connect your transceiver. If you have any difficulties, reread the information above and the helpful hints below.

## HELPFUL HINTS

- Try to locate your R7000 as far away from TV antennas and their feedlines as possible. This will help to avoid overloading your television with RF.
- The dimensions recommended in figure F are based on mounting the R7000 approximately 8 feet (2.4 meters) above the ground and 25 feet (7.5 meters) from surrounding objects. Antennas installed with less clearance may require additional adjustments.
- If you check the resistance across the coax connector on your R7000 you will find a DC short. This is normal. It does not mean that the RF path is short circuited. It is approximately 50 Ohms at your operating frequencies.
- High VSWR is sometimes caused by poor contact between the matching network and the counterpoise rods. Make sure that corrosion has not formed on the jumper strap terminals. Check to insure the hardware is tight.
- If your R7000 is very close to your shack you may experience RF on the feedline. Try lengthening your feedline several feet, placing an RF ferrite bead on the coax, winding the feedline on a toroid or winding the coax in a 10 turn coil 8 inches (20 cm) in diameter.
- Weather sealing the matching network is not necessary. We have provided a large hole near the coax connector to allow air to circulate through the box and to keep it dry. Keep this hole clear to avoid difficulties caused by humidity and condensation.
- Long periods (2 minutes or longer) of key down operation, such as RTTY, at high power (over 1000 Watts) may damage your R7000.

# MASTER PARTS LIST

KEY	PART#	DESCRIPTION	QTY	KEY	PART#	DESCRIPTION	QTY
BA		Base assembly with rings	1	62	014162	#10 stainless steel nut/washer	1
BB		1-1/4" x 48" (3.2 x 121.9 cm) aluminum tube slotted one end	1	63	170063	2" aluminum V-block	4
				73	194173	Radial ring bracket	4
BC		1" x 48" (2.5 x 121.9 cm) aluminum tube slotted one end	1	79	010079	#8-32 x 1/2" (1.3 cm) stainless steel machine screw	4
BD		7/8" x 12" (2.2 x 30.5 cm) aluminum tube slotted both ends	2	96	010096	#8-32 x 3/8" (.95 cm) stainless steel machine screw	4
				115	050115	Connector boot	1
BE		7/8" x 18" (2.2 x 45 cm) aluminum tube slotted both ends	1	116	240116	Silicone package	1
BG		3/4" x 48" (1.9 x 121.9 cm) aluminum tube	1	120	010120	#8-32 x 2" (5.1 cm) stainless steel machine screw	1
CT1		10/12 meter trap assembly	1	160	190160	Matching network upper bracket	1
CT2		15/17 meter trap assembly	1	231	010231	#8-32 x 1-3/4" (4.4 cm) stainless steel machine screw	2
CT3		20/30 meter trap assembly	1	232	010232	#8-32 x 2-1/2" (6.3 cm) stainless steel machine screw	2
XHR		3/16" x 36" (.48 x 91.4 cm) aluminum rod drilled center	2	326	290326	Warning label	8
MN7000		Matching network	1	404	010404	2-7/16" x 3-1/4" (6.2 x 8.3 cm) stainless steel U-bolt	2
				405	010405	2-7/16" x 4-1/2" (6.2 x 11.4 cm) stainless steel U-bolt	2
12	050012	3/4" (1.9 cm) plastic cap	1	410	030410	1" (2.5 cm) stainless steel worm clamp	6
26	190026	7/8" (2.22 cm) formed aluminum bracket	2	411	030411	1-1/4" (3.2 cm) stainless steel worm clamp	1
28	190028	Aluminum halfwasher	2	412	030412	1-1/2" (3.8 cm) stainless steel worm clamp	1
32	902832	49" (124.5 cm) stainless steel radial rod	7	413	030413	1-3/4" (4.4 cm) stainless steel worm clamp	1
49	014149	#8 stainless steel nut/washer	16	428	902428	Jumper strap	1
51	014151	5/16" (.8 cm) stainless steel nut/washer	8	4079	194079	Aluminum mounting plate	1

TA5FA

# #1 - ASSEMBLE AND ATTACH RADIAL RING

**FIGURE A**

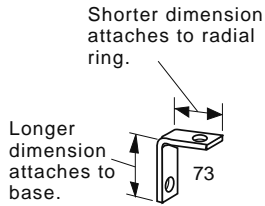

Loosely attach radial ring brackets (73) and strap (428) to radial the rings which are located on the fiberglass section of the base assembly with 4 machine screws (79) and nut/washers (49) as shown in Figure B. Be aware of the proper orientation of this bracket as shown in Figure A. Loosely attach 4 shorter screws (96) and nuts (49) onto the radial ring (Figure C). Referring to Figure D attach this assembly to the base with 2-1/2" screws (232) and nuts (49). Leave all screws loosely fastened.

**FIGURE B**

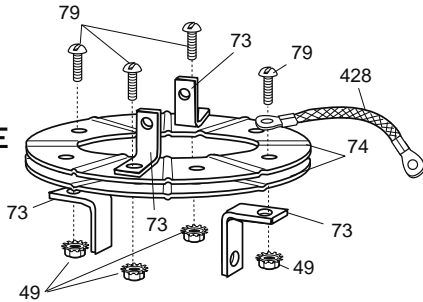

KEY	P/N	DISPLAY	DESC	SIZE	QTY
49	014149		NUT/WASHER	8-32	10
73	194173		RADIAL RING BRACKET		4
79	010079		SS MACHINE SCREW	8-32 x 1/2" (1.3 cm)	4
96	010096		SS MACHINE SCREW	8-32 x 3/8" (.95 cm)	4
232	010232		SS MACHINE SCREW	8-32 x 2-1/2" (6.35 cm)	2
428	902428		STRAP		1

**FIGURE C**

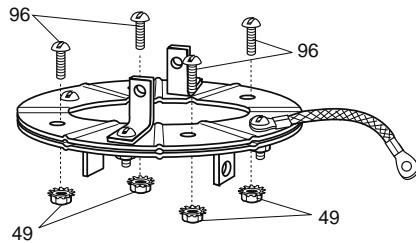

**FIGURE D**

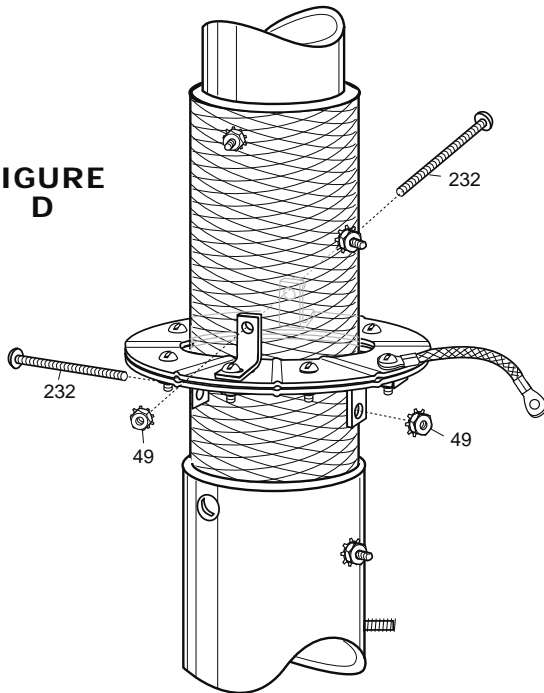

TA5FA

## #2 - ATTACH MATCHING NETWORK AND RADIALS

One at a time, place the stainless steel radial rods into the slots of the radials rings. Tighten the corresponding ring screws as you work your way around the rings. The radial rods do not have to touch each other to secure the radial rods properly so do not overtighten the screws. When all 7 radial rods are secure, tighten the two screws holding the radial ring brackets to the base. Attach warning labels (326) as shown in Figure E.

Attach matching network upper bracket (160) to base assembly (BA) using screw (120) and nut/washer (49). Attach MN7000 to base assembly by inserting the two 8-32 mounting screws into the upper bracket (160) and securing screws with two nut/washers (49). Place bottom of MN7000 over the 10-24 captive screw and secure with nut/washer (62). Connect braid from radial ring to MN7000 screw as shown using nut/washer (49).







KEY	P/N	DISPLAY	DESC	SIZE	QTY
32	902832		SS RADIAL	49" (124.5 cm)	7
49	014149		NUT/WASHER	8-32	4
62	014162		SS NUT/WASHER	10-24	1
120	010120		SS MACHINE SCREW	8-32 x 2" (5.1 cm)	1
160	190160		MN7000 BRACKET		1
326	290326		WARNING LABEL		7
	MN7000		MATCHING NETWORK		1

FIGURE E

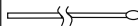

TA5FA

# #3 - ASSEMBLE RADIATOR

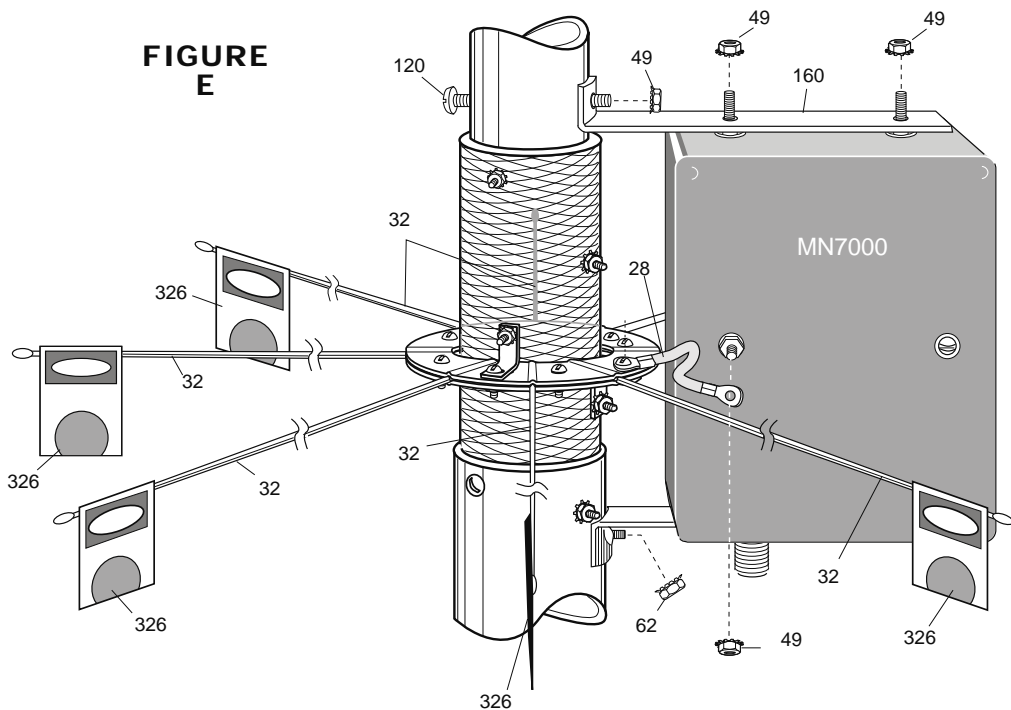
Place worm clamp (413) over top end of base assembly (BA). Note Figure G for proper positioning of all worm clamps. Slide section BB into BA 4 inches and secure worm clamp. Place worm clamp (412) over slots of section BB. Slide section BC into BB 4 inches and secure worm clamp. Attach capacity hat rods (XHR) to BC using hardware shown in Figure G. Place worm clamp (411) over slots of section BC. Hold trap assembly CT1 with capped end up and slide bottom tube into section BC until it is stopped by the XHR mounting screws and secure worm

clamp. Place worm clamps (410) over each end of section BD. Slide BD over CT1 top tube 2" and secure worm clamp. Hold trap assembly CT2 with capped end up and slide bottom tube into BD 2" and secure worm clamp. Place worm clamps (410) over each end of section BD. Slide BD over CT2 top tube 3" and secure worm clamp. Hold trap assembly CT3 with capped end up and slide bottom tube into BD 3-1/2". Secure worm clamp. Place worm clamps (410) over each end of section BD. Slide BE over CT3 top tube 5" and secure worm clamp. Slide BG into BE 5" and secure worm clamp. Install cap (12). Verify all radiator dimensions to within 1/4" (.6 cm) using Figure F.

KEY	P/N	DISPLAY	DESC	SIZE	QTY
12	050012		PLASTIC CAP	3/4" (1.9 cm)	1
26	190026		ALUMINUM BRACKET	7/8" (2.2 cm)	2
28	190028		ALUMINUM HALF WASHER		2
49	014149		NUT/WASHER	8-32	2
231	010231		SS MACHINE SCREW	8-32 x 1-3/4" (4.4 cm)	2
410	030410		SS WORM CLAMP	1" (2.5 cm)	6
411	030411		SS WORM CLAMP	1-1/4" (3.2)	1
412	030412		SS WORM CLAMP	1-1/2" (3.8 cm)	1
413	030413		SS WORM CLAMP	1-3/4" (4.4 cm)	1
BA			BASE ASSEMBLY		1
BB			ALUMINUM TUBE	1-1/4" x 48 (3.2 x 121.9 cm)	1
BC			ALUMINUM TUBE	1" x 48" (2.5 x 121.9 cm)	1
BD			ALUMINUM TUBE	7/8" x 12" (2.2 x 30.5 cm)	2
BE			ALUMINUM TUBE	7/8" x 18" (2.2 x 45 cm)	1
BG			ALUMINUM TUBE	3/4" x 48" (1.9 x 121.9)	1
CT1			10/12 M TRAP		1
CT2			15/17 M TRAP		1
CT3			20/30 M TRAP		1
XHR			ALUMINUM ROD	3/16" x 36" (.5 x 91.4 cm)	2

Chart A

Dimension D (in)	Center Frequency (cm)	Center Frequency (MHz)
53	134.5	7.300
54	137	7.275
56	142	7.225
58	147	7.175
60	152.5	7.125
62	157.5	7.075
64	162.5	7.025
65	165	7.000

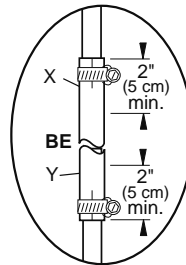

**NOTE:** When installing BE tube, ensure at least 2" (5 cm) length of the adjoining 3/4" (1.9 cm) tubes are inserted into R7000BE (Figure A, points X and Y).

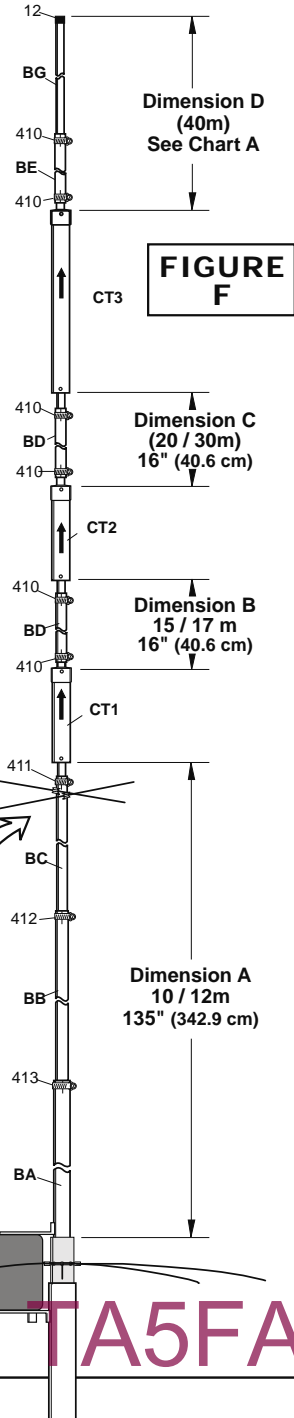

Secure hose clamps about 1/4" from top of each slotted tube to ensure adequate compression.

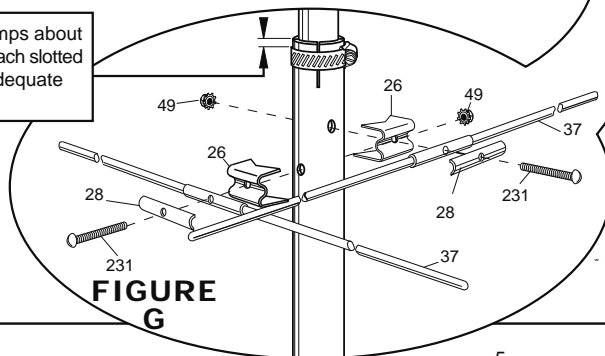



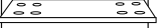



FIGURE G

TA5FA

## #4 - BASE TO MAST ASSEMBLY

Attach the antenna base to your mast as shown in Figure H. First attach the mounting plate (4079) with U-bolts (404), aluminum V-blocks (63), and nut/washers (51) to the antenna base. The bottom of the plate should be even with the bottom of the antenna to leave room for the radial clamping system. Affix danger label (326) to the antenna so that is easy to see. When attaching mounting plate to the mast use the (405) U-bolts, aluminum V-blocks (63), and nut/washers (51).

KEY	P/N	DISPLAY	DESC	SIZE	QTY
51	014151		NUT/WASHER	5/16" (.8 cm)	8
63	170063		V-BLOCK	2" (5.1 cm)	4
404	010404		U-BOLT	2-7/16 x 3-1/4" (6.2 x 8.2 cm)	2
405	010405		U-BOLT	2-7/16" x 4-1/2" (6.2 x 11.4 cm)	2
4079	194079		MOUNTING PLATE		1
326	290326		WARNING LABEL		1

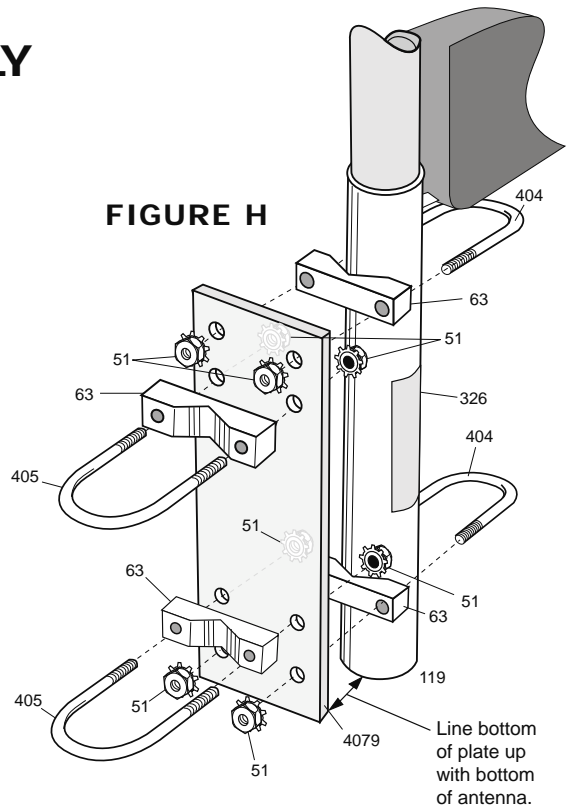

## #5 - FEEDLINE

The R7000 is designed for use with 50 Ohm coaxial cable terminated with a PL-259 connector. The shortest length of cable will have the least loss. A connector boot is included for use with your new antenna (figure I). Slide the boot over the cable before attaching your PL-259. Coat only the outside connector threads and shell with silicone grease. Do not coat the center pin or receptacle. After the PL-259 is firmly screwed onto the antenna connector, slide the vinyl boot over the connector and against the connector bracket for a good weather-tight connection. After the antenna is on the mast, tape the feedline to the mast. If you plan to install the antenna in a salty or corrosive environment, you may want to consider coating it with a clear marine varnish or equivalent after it is assembled. For final tuning see page 1.

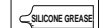
KEY	PART#	DESCRIPTION	SIZE	QTY
115	050115	 CONNCTOR BOOT		1
116	240116	 SILICONE GREASE		1

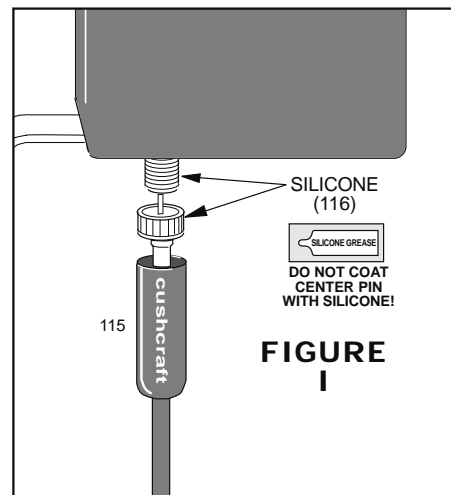

TA5FA



## SPECIFICATIONS

Frequency Coverage, meters	10, 12, 15, 17, 20, 30, 40
Gain, dBi	3
Electrical Wavelength each band	Half-wave
VSWR 1.2:1 Typical	
2:1 Bandwidth (KHz)	10m (1700), 12m (100), 15m (450), 17m (100) 20m (250), 30m (100), 40m (150)
Power Rating, Watts PEP	1500
Radiation Angle, degrees	16
Horizontal Radiation Pattern, degrees	360
Height, ft (m)	24 (7.31m)
Mast Size Range, in (cm)	1.75-2.125 (4.4-5.4 cm)
Wind Load, ft <sup>2</sup> (m <sup>2</sup> )	2 (.2)
Weight, lb (kg)	18 (8.2)

### LIMITED WARRANTY

Cushcraft Corporation, P.O. Box 4680, Manchester, New Hampshire 03108, warrants to the original purchaser for one year from date of purchase that each Cushcraft antenna is free of defects in material or workmanship. If, in the judgement of Cushcraft, any such antenna is defective, then Cushcraft Corporation will, at its option, repair or replace the antenna at its expense within thirty days of the date the antenna is returned (at purchasers expense) to Cushcraft or one of its authorized representatives. This warranty is in lieu of all other expressed warranties, any implied warranty is limited in duration to one year. Cushcraft Corporation shall not be liable for any incidental or consequential damages which may result from a defect. Some states do not allow limitations on how long an implied warranty lasts or exclusions or limitations of incidental or consequential damages, so the above limitation and exclusion may not apply to you. This warranty gives you specific legal rights, and you may also have other rights which vary from state to state. This warranty does not extend to any products which have been subject the misuse, neglect, accident or improper installation. Any repairs or alterations outside of the Cushcraft factory will nullify this warranty.



48 PERIMETER ROAD, MANCHESTER, NH 03108 USA  
TELEPHONE: 603-627-7877 • FAX: 603-627-1764 • E-mail: techsup@cushcraft.com

TA5FA