



**ASSEMBLY &  
INSTALLATION**



**20-15-10 Meter Nine Element Beam**



**CUSHCRAFT**  
COMMUNICATIONS ANTENNAS

**TA5FA**  
951471 (9/98)

Thank you for your purchase of the Cushcraft X9 Tribander. This antenna is designed and manufactured to give the best performance and trouble free service. The antenna will perform as specified if the instructions are followed during assembly and installation. Cushcraft operates a full service Technical Support staff to answer questions regarding assembly, tuning, parts and just about everything else. Please contact us by phone (603) 627-7877 (8 AM - 5PM Eastern Time), FAX (603) 627-1764, or email techsup@cushcraft.com for prompt service.

**WARNING**

THIS ANTENNA IS AN ELECTRICAL CONDUCTOR. CONTACT WITH POWER LINES CAN RESULT IN DEATH OR SERIOUS INJURY. DO NOT INSTALL THIS ANTENNA WHERE THERE IS ANY POSSIBILITY OF CONTACT WITH OR HIGH VOLTAGE ARC-OVER FROM POWER CABLES OR SERVICE DROPS TO BUILDINGS. THE ANTENNA, SUPPORTING MAST AND/OR TOWER MUST NOT BE CLOSE TO ANY POWER LINES DURING INSTALLATION, REMOVAL OR IN THE EVENT PART OF THE SYSTEM SHOULD ACCIDENTALLY FALL. FOLLOW THE GUIDELINES FOR ANTENNA INSTALLATION RECOMMENDED BY THE U.S. CONSUMER PRODUCT SAFETY COMMISSION AND LISTED IN THE ENCLOSED PAMPHLETS.

**Antenna System Planning**

Before assembly, take time to review your installation plans for the antenna. Location of the antenna is very important. Surrounding objects such as trees, power lines, buildings, and other antennas will interact with an HF Yagi. To minimize the effects of surrounding objects, mount the antenna as high and in the clear as possible. Metallic guy wire within 30 feet of this antenna should be broken with strain insulators to improve performance.

**40 Meter Add-On Kit**

The X940 40 meter add-on kit is available for the X9. The kit consists of a loaded dipole element that is mounted on the boom section BA between Elements #2 and #3. The 40 meter element requires a separate coax feed. Contact Cushcraft or your dealer for more information.

YOU MUST INSURE THAT NEITHER PEOPLE OR PETS CAN COME IN CONTACT WITH YOUR ANTENNA WHILE IT IS IN OPERATION. DEADLY VOLTAGES AND CURRENTS MAY EXIST. ALSO, SINCE THE EFFECTS OF EXPOSURE TO RF ARE NOT FULLY UNDERSTOOD, LONG TERM EXPOSURE TO INTENSE RF FIELDS IS NOT RECOMMENDED. THERE IS A WARNING STICKER WHICH MUST BE ATTACHED TO THE BOOM AS SHOWN IN FIGURE 8A.

Plan your installation carefully. If you use volunteer helpers be sure that they are qualified to assist you. Make certain that everyone involved understands that you are in charge and that they must follow your instructions. If you have any doubts at all, employ a professional antenna installation company to install your antenna.

**System Grounding**

Direct grounding of the antenna, mast and tower is very important. This serves as protection from lightning strikes and static buildup. A good electrical connection should be made to one or more ground rods directly at the base of the tower or mast using at least #10 AWG ground wire and non-corrosive hardware. For details and safety standards, consult the National Electrical Code. A coaxial lightning arrester should be used. Cushcraft offers several different models such as the LAC series.

**Assembly**

The assembly procedure for the X9 consists of assembling the following subassemblies.

- 1) Verification of Parts. 2) Boom Assembly. 3) Element Assembly. 4) Element to Boom Assembly. 5) Feed System Assembly. 6) Boom to Mast Clamp Assembly. 7) Boom Truss Assembly.**

Assembly of the X9 will be easiest if the preceding steps are performed in the given order. For easier tower mounting, some or all of the elements may be mounted to the boom when the antenna is on the tower. If this option is chosen, the feed system can be attached after the elements are mounted.

*Please read through the entire assembly procedure before beginning.*

**NOTE: If you plan to install the 40 meter add-on kit, please read the X940 manual before you assemble the X9.**

# 1-Verification of Parts

Verify all parts are present by using the X9 Master Parts List. Check off each part when it is counted. There are extra parts intentionally shipped with this antenna. Place common hardware in temporary containers for ease of assembly.

Part No.	Description	Metric Equivalent	Quantity	Qty Check
014597	#8-32 x 3" Stainless Steel Machine Screw	#8 x 7.6 cm	2	___
X9EW	7/8" x 12" Aluminum tube slotted 2 ends	2.2 x 30.5 cm	1	___
X9EX	1/2" x 32" Aluminum tube	1.3 x 81.2 cm	2	___
X99FS	1/2" Tinned Copper Braid 6" Long with Lugs	1.2 cm x 15 cm	2	___
010011	#8-32 Stainless Steel Nut		10	___
010082	1/4-20 x 1" Hex Bolt	0.6 cm - 20 x 2.5 cm	56	___
010084	1/4" Stainless Steel Lock Washer	0.6 cm	107	___
010085	1/4-20 Stainless Steel Nut	0.6 cm	19	___
010120	#8-32 x 2" Stainless Steel Machine Screw	#8 x 5.1 cm	4	___
010123	#8-32 x 1 1/2" Stainless Steel Machine Screw	#8 x 3.8 cm	4	___
010207	3/8" Stainless Steel Flat Washer	0.9 cm	10	___
010208	3/8" Stainless Steel Lock Washer	0.9 cm	10	___
010209	3/8" Stainless Steel Nut	0.9 cm	10	___
011941	#8 Stainless Steel Lock Washer		10	___
013209	2-7/8" Center-to-center U-Bolt 4" Long	7.3 cm -10.2 cm Long	5	___

**TA5FA**

## Verification of Parts continued

Part No.	Description	Metric Equivalent	Quantity
014387	#8-32 Stainless Steel Lock Nut		12
014399	1/4" Stainless Steel Lock Nut	0.6 cm	105
014495	7/8" Cush-a-Clamp®	2.2 cm	6
014496	1" Cush-a-Clamp®	2.5 cm	4
014497	1-1/4" Cush-a-Clamp®	3.2 cm	8
014588	1/4" x 3-1/2" Stainless Steel Hex Bolt	0.6 x 8.9 cm	15
014592	1/4" Stainless Steel Flat Washer 1/8" Thick	0.6 x 0.3 cm	16
024259	1/8" Thimble	0.3 cm	4
024624	1/8" Cable clamp	0.3 cm	12
024623	5/16" x 4" Turnbuckle	0.8 x 10 cm	2
030407	5/8" Worm Clamp	1.6 cm	14
030409	11/16" Worm Clamp	1.7 cm	18
030410	1" Worm Clamp	2.5 cm	26
030411	1-1/8" Worm Clamp	2.9 cm	8
030412	1-1/2" Worm Clamp	3.8 cm	8
050053	1/2" Black Plastic Cap	1.3 cm	4
050077	3/8" Black Plastic Cap	0.9 cm	14
054526	2-1/2" Black Plastic Cap	6.4 cm	2
094622	35' Phillystran cable	8.9m	1
124565	5/8" x 8" Drilled Fiberglass Insulator	1.6 x 20.3 cm	2
124566	7/8" x 8" Drilled Fiberglass Insulator	2.2 x 20.3 cm	1
124567	1" x 8" Drilled Fiberglass Insulator	2.5 x 20.3 cm	1
154554	3" x 2-1/2" x 1" Tuning Tube Insulator	7.6 x 6.3 x 2.5 cm	1
170035	2-1/2" Formed Aluminum Vee Blocks	6.4 cm	5
194542	8" x 8" x 1/4" Aluminum Mounting Plate	20.3 x 20.3 x 0.6 cm	1
194555	2-7/8" x 1" x 1/4" Tuning Tube Shorting Strap	7.3 x 2.5 x .6 cm	1
194618	6" x 12" x 1/4" Aluminum mounting plate	15.2 x 30 x 0.6 cm	1
194791	2" x 4" x 1/8" Drilled aluminum truss bracket	5.1 x 10.2 x 0.3 cm	1
244604	NOALOX® conductive lubricant		1
290326	Danger Label		1
323832	2" x 1-1/2" x 1/8" Feed Strap Plastic Insulator	5.1 x 3.8 x .3 cm	3
324504	3" x 5-1/4" x 1/8" Drilled Extruded Aluminum Bracket	7.6 x 13.3 x 0.3 cm	6
324506	8" x 5-1/4" x 3/16" Drilled Extruded Aluminum Bracket	20.3 x 13.3 x 0.5 cm	2
324509	4" x 5-1/4" x 3/16" Drilled Extruded Aluminum Bracket	10.2 x 13.3 x 0.5 cm	12
324564	1" x 5-1/4" x 1/8" Drilled Extruded Aluminum Bracket	2.5 x 13.3 x 0.3 cm	2
330885	Brush		1
T2	17" 10 meter Director Trap	43 cm	2
T4	19" 15 meter Director Trap	48 cm	2
T6	20-3/4" 15 Meter Director Trap	52.7 cm	2
TD	16-1/2" 10 Meter Director Trap	42 cm	2
MXN79	Matching Network	42 cm	1
BA	2-1/2" x 84" Drilled Aluminum Tube	6.4 x 213 cm	1
BB	2-1/2" x 72" Drilled Aluminum Tube	6.4 x 182 cm	1
BC	2-1/2" x 54" Drilled Aluminum Tube	6.4 x 137 cm	1
BD	2-1/2" x 66" Drilled Aluminium Tube	6.4 x 167 cm	1
BE	2-1/2" x 84" Drilled Aluminum Tube	6.4 x 213 cm	1
EA	1-1/4" x 72" Aluminum Tube slotted 2 ends	3.2 x 183 cm	1
EB	1-1/8" x 52" Aluminum Tube slotted 1 end, 1" tube insert 1 end	2.8 x 132 cm	4
EC	1" x 36" Aluminum Tube slotted 7/8" swege 1 end	2.5 x 91 cm	4
ED	3/4" x 36" Aluminum Tube slotted 5/8" swege 1 end	1.9 x 91 cm	10
EE	1/2" x 36" Aluminum Tube slotted 1 end	1.3 x 91 cm	8
EF	3/8" x 48" Aluminum Tube	1.0 x 122 cm	4
EG	1" x 48" Aluminum Tube slotted 2 ends	2.5 x 122 cm	1
EH	7/8" x 48" Aluminum Tube slotted 1 end	2.2 x 122 cm	2
EJ	3/8" x 32" Aluminum Tube	1.0 x 81 cm	4
EK	1" x 24" Aluminum Tube slotted 1 end, drilled 1 end	2.5 x 61 cm	2
EL	1-1/4" x 36" Aluminum Tube, slotted 1 end, drilled 1 end	3.2 x 91 cm	2
EM	1/2" x 24" Aluminum Tube slotted 1 end	1.3 x 61 cm	6
EN	3/8" x 36" Aluminum Tube	1.0 x 91 cm	6
EP	1-1/4" x 48" Aluminum Tube slotted 2 ends	3.2 x 122 cm	2
ER	1-1/8" x 48" Aluminum Tube slotted 1 end	2.9 x 122 cm	4
ES	1/2" x 36" Aluminum Tube	1.3 x 91 cm	2
ET	7/8" x 36" Aluminum Tube slotted 1 end	2.2 x 91 cm	2
EU	3/4" x 36" Aluminum Tube slotted 5/8" OD swege 1 end, drilled 1 end	1.9 x 91 cm	4
EV	1" x 36" Aluminum Tube slotted 1 end	2.5 x 91 cm	4
EX	1/2" X 32" Aluminum Tube	1.3 x 81 cm	2
EY	1" x 5-1/4" Aluminum Tube slotted 2 ends	2.5 x 13.3 cm	4
EZ	3/8" x 30" Intentionally Bent Aluminum Tube crimped and drilled 1 end	1.0 x 76 cm	2
FL1	5/8" x 16" Aluminum Flat Feedline Strap	0.9 x 41 cm	2
FL2	5/8" x 20-3/4" Aluminum Flat Feedline Strap	0.9 x 53 cm	2
FL3	5/8" x 28-3/4" Aluminum Flat Feedline Strap	0.9 x 73 cm	2

TA5FA

**Figure 1**

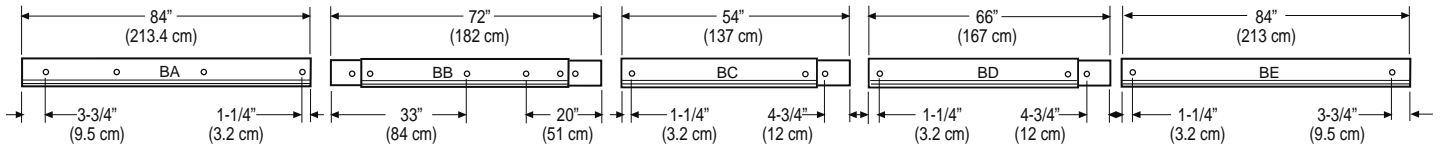

**Figure 2**

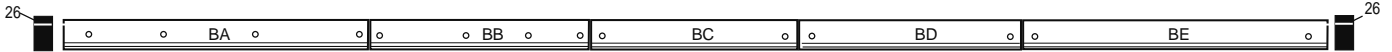

**Figure 3**

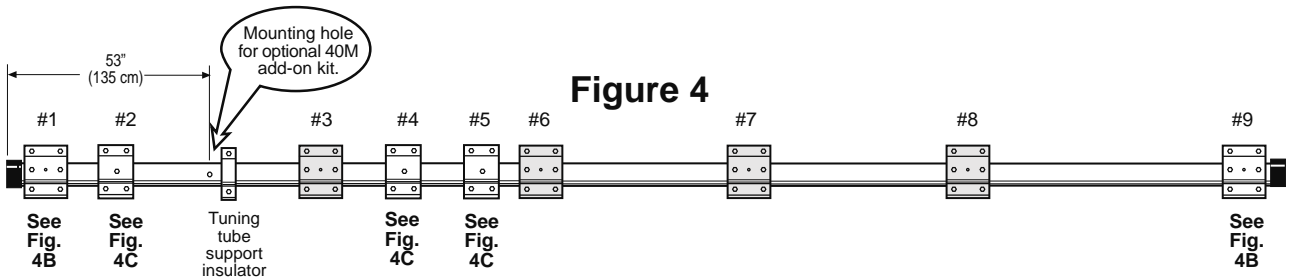
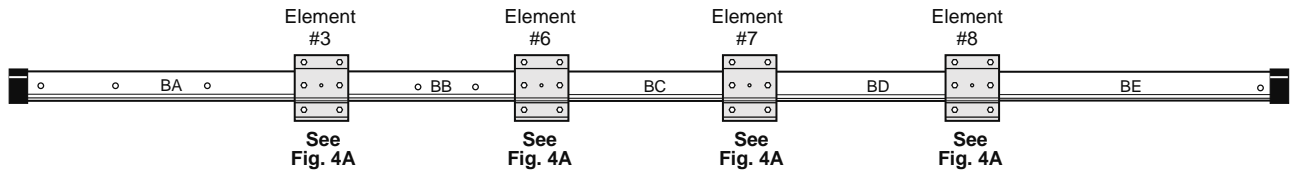

*NOTE: The X9 is shipped with NOALOX® conductive lubricant and an applicator brush. Apply small amounts of the lubricant to telescoping tubing sections during element and boom assembly. Apply small amounts of lubricant to bolt/U-bolt threads to prevent galling (seizing) of the nuts during assembly. Also, apply small amounts to the feedstrap assembly and matching network connections.*

## 2-Boom Assembly

Figures 1, 2, 3 and 4 show the steps for boom assembly. Identify the tubing sections, element brackets and hardware required for this step by using the Boom Subassembly Parts List. Note the element brackets for Elements #3, #6, #7 and #8 join the boom sections (Figure 3).

Refer to Figures 4A, 4B, 4C and 4D to assemble element brackets. The 1/4" hex nuts (85) are used as spacers on all brackets. Tighten these nuts in place before assembling element bracket halves. The 1/4" flat washers (1/8" thick) (529) are used on brackets as spacers (Figures 4A, 4B, 4C). The Boom may be placed on a flat surface with all brackets laying flat on the surface. This will allow all brackets to be fastened in line with each other. When tightening the hardware, refer to Figure 4A and tighten all bracket hardware in this order. Do not tighten the bolts on the Tuning Tube Support Insulator Bracket (Figure 4D). Allow the bracket to remain loose on the boom for Step 5 (Feed System Assembly).

Nylon insert lock nuts are designed for one-time use. Do not tighten these nuts if you expect to disassemble antenna sections during antenna mounting.

After mounting boom end caps (26), drill a small hole (1/4") in the bottom edge of the cap for water drainage. Determine which edge of the end cap will be on the ground facing side of the boom when antenna is mounted in its final position.

ID	Part #		Description	Dimensions	Qty
82	010082		Hex Bolt	1/4-20 x 1" (.6 x 2.5 cm)	30
84	010084		SS Lock Washer	1/4" (.6 cm)	50
85	010085		SS Nut	1/4-20 (.6 cm)	19
99	014399		SS Lock Nut	1/4" (.6 cm)	50
504	324504		Aluminum Bracket	3" x 5-1/4" x 1/8" (7.6 x 13.3 x .3 cm)	6
509	324509		Aluminum Bracket	4" x 5-1/4 x 3/16" (10.2 x 13.3 x .5 cm)	12
564	324564		Aluminum Bracket	1" x 5-1/4" x 1/8" (2.5 x 13.3 x .3 cm)	2
588	014588		SS Hex Bolt	1/4" x 3-1/2" (.6 x 10.2 cm)	13
592	014592		SS Flat Washer	1/4" (1/8" thick) (.6 x .3 cm)	16

TASFA

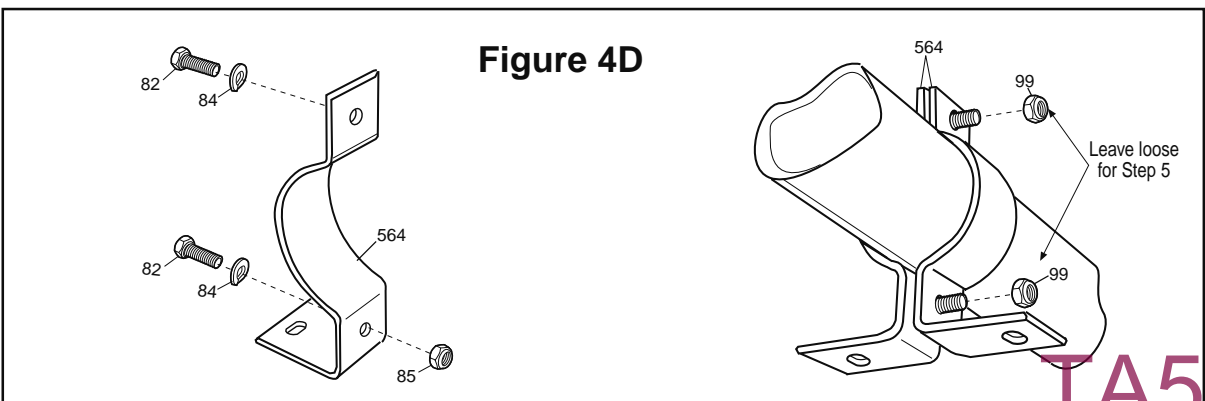
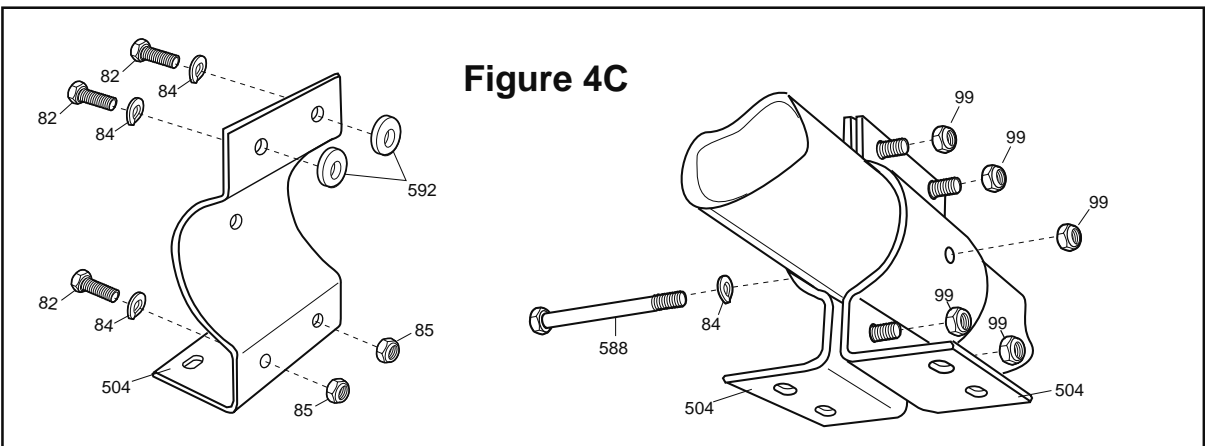
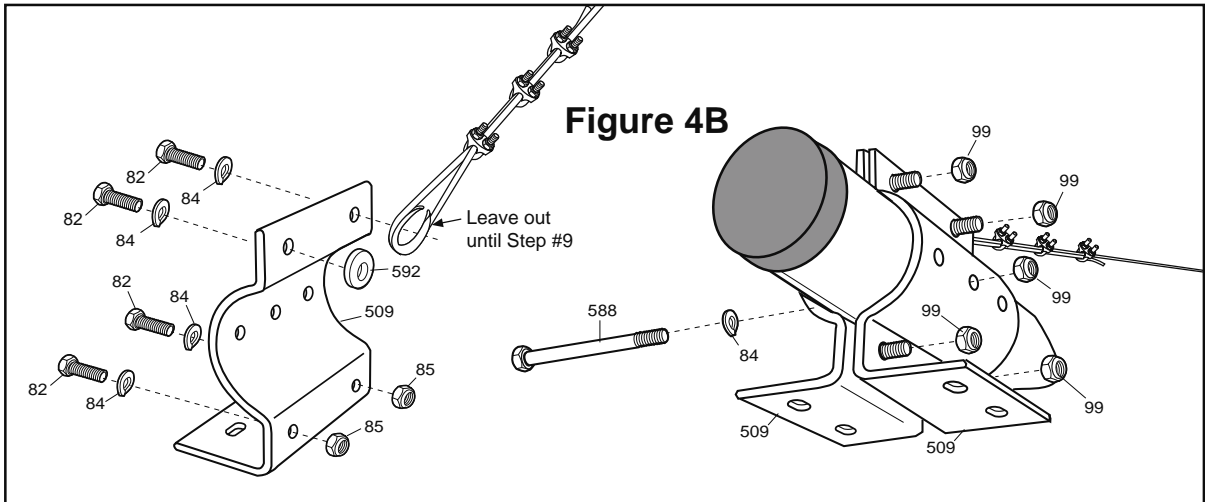
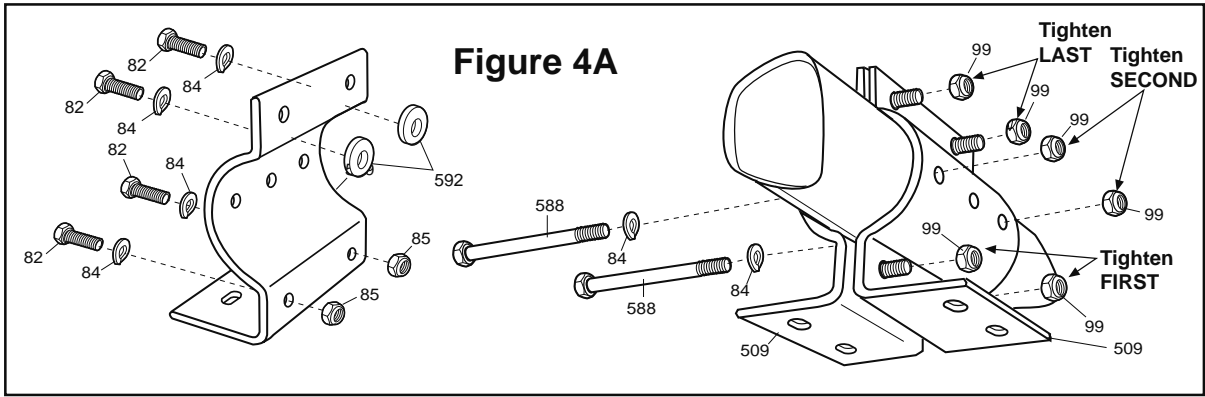

TA5FA

# 3-Element Assembly

Figures 5, 5A, 5B, and 5C show the steps for element assembly. Identify the tubing sections required for each element using the Element Subassembly Parts List. Each telescoping tubing section is inserted 4 inches into the larger section except where noted in Figure 5. Adjust the length of the end tubing section to give each element the proper total half length. All dimensions should be within 1/4 inch of the values given. Mark the center of tubing sections EA, EG, and EP with a marker as shown in Figure 6A. These marks will be used in Step 4 when elements are mounted on the boom. The dimension between traps TB and T2 is measured between the ends of each trap. The 75 inch dimension from element #7 center is measured to the end of trap T2. The dimension between traps T4 and TD is measured between the ends of each trap. The 72-1/2" dimension from element #9 center is measured to the end of trap TD. Insure all traps are installed with arrows pointing toward the boom. Also position trap drain holes so they will be facing the ground when the antenna is in its final position.

Install all worm clamps as shown. Take care not to overtighten and strip the worm clamp. Apply electrical tape over the worm clamp and tubing. This will keep the worm clamps from snagging wires or ropes in the future. Extra worm clamps are provided. Note that all element sections can be fastened using a self-taping screw at each tubing transition. Use stainless screws for best performance. Properly installed worm clamps will provide years of trouble free service.

The X9 is constructed entirely with .058-inch wall tubing. This creates a tight transition between tubing sections with the closest possible fit and better ice-loading characteristics than antennas constructed with thinner wall tubing. Elements 3, 4, 5 and 6 have fiberglass center sections. Reference figures 5A, 5B and 5C for proper assembly.

After mounting element end caps (53, 77) punch a small hole (1/4") in the bottom edge (ground facing side) of each cap for water drainage.

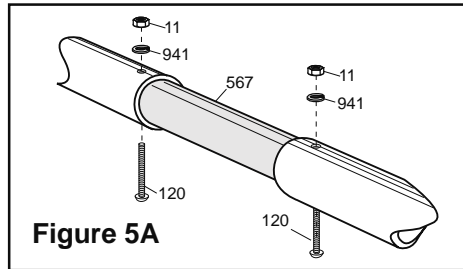

Figure 5A

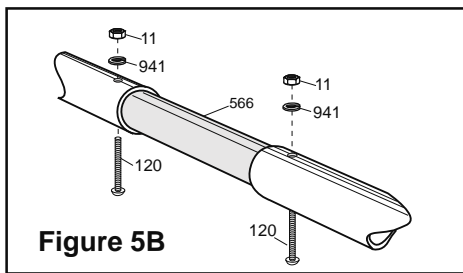

Figure 5B

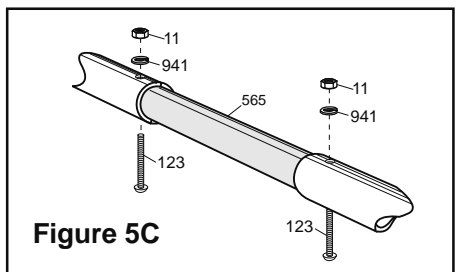
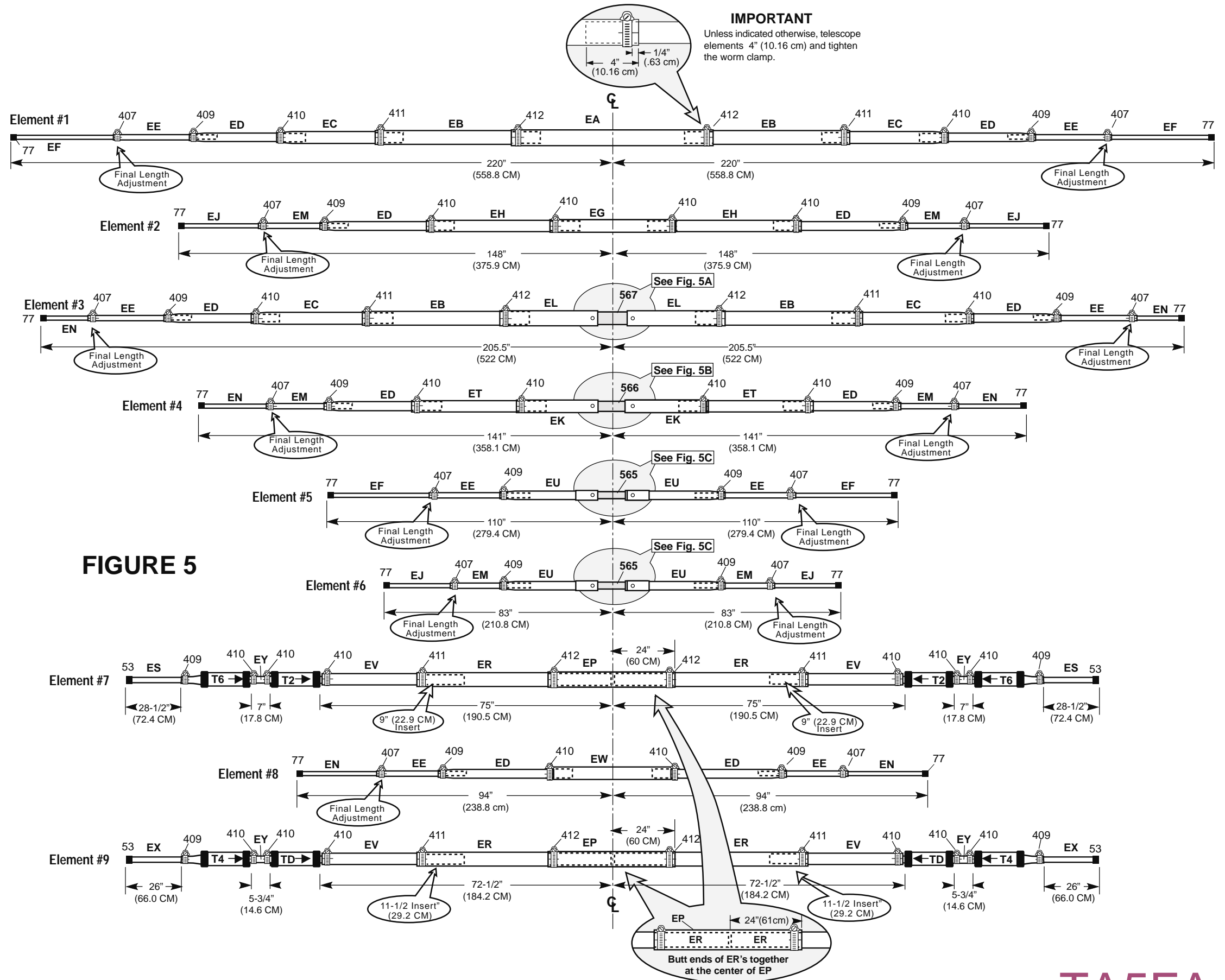



















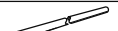

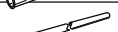

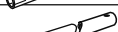
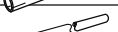
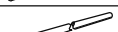
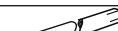



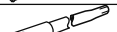
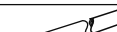
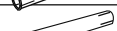

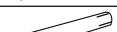
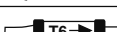
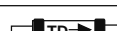
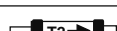
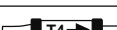

Figure 5C



# 3-Element Assembly Parts List

ID	Part #		Description	Dimensions	Qty
11	010011		SS Nut	#8-32	8
53	050053		Black Plastic Cap	1/2" (1.3 cm)	4
77	050077		Black Plastic Cap	3/8" (0.9 cm)	14
120	010120		SS Machine Screw	#8-32 x 2" #8 x 5.1 cm)	4
123	010123		SS Machine Screw	#8-32 x 1-1/2" #8 x 3.8 cm)	4
407	030407		Worm Clamp	5/8" (1.6 cm)	12
409	030409		Worm Clamp	11/16" (1.7 cm)	14
410	030410		Worm Clamp	1" (2.5 cm)	18
411	030411		Worm Clamp	1-1/8" (2.9 cm)	6
412	030412		Worm Clamp	1-1/2" (3.8 cm)	6
565	124565		Fiberglass Insulator	5/8" x 8" (1.6 x 20.3 cm)	2
566	124566		Fiberglass Insulator	7/8" x 8" (2.2 x 20.3 cm)	1
567	124567		Fiberglass Insulator	1" x 8" (2.5 x 20.3)	1
941	011941		SS Lock Washer	#8	8
EA	X79EA		Aluminum Tube	1-1/4" x 72" (3.2 x 183 cm)	1
EB	X79EB		Aluminum Tube	1-5/8" x 52" (2.8 x 132 cm)	4
EC	E79EC		Aluminum Tube	1" x 36" 2.5 x 91 cm)	4
ED	X79ED		Aluminum Tube	3/4" x 36" (1.9 x 91 cm)	10
EE	X79EE		Aluminum Tube	1/2" x 36" (1.3 x 91 cm)	8
EF	E79EF		Aluminum Tube	3/8" x 48" (1.0 x 122 cm)	4
EG	E79EG		Aluminum Tube	1" x 48" (2.5 x 122 cm)	1
EH	E79EH		Aluminum Tube	7/8" x 48" (2.2 x 122 cm)	2
EJ	E79EJ		Aluminum Tube	3/8" x 32" (1.0 x 81 cm)	4
EK	X79EK		Aluminum Tube	1" x 24" (2.5 x 61 cm)	2
EL	X79EL		Aluminum Tube	1-1/4" x 36" (3.2 x 91 cm)	2
EM	X79EM		Aluminum Tube	1/2" x 24" (1.3 x 61 cm)	6
EN	X79EN		Aluminum Tube	3/8" x 36" (1.0 x 99 cm)	6
EP	X79EP		Aluminum Tube	1-1/4" x 48" (3.2 x 122 cm)	2

ER	X79ER		Aluminum Tube	1-1/8" x 48" (2.9 x 122 cm)	4
ES	X79ES		Aluminum Tube	1/2" x 36" (1.3 x 91 cm)	2
ET	X79ET		Aluminum Tube	7/8" x 36" (2.2 x 91 cm)	2
EU	X79EU		Aluminum Tube	3/4" x 36" (1.9 x 91 cm)	4
EV	X79EV		Aluminum Tube	1" x 36" (2.5 x 91 cm)	4
EW	X9EW		Aluminum Tube	7/8" x 12" (2.2 x 30.5 cm)	1
EX	X9EX		Aluminum Tube	1/2" x 32" (1.3 x 81 cm)	2
EY	A34SEF		Aluminum Tube	1" x 5-1/4" (2.5 x 13.3 cm)	2
T6	T6		15 M Trap	20-3/4" (52.7 cm)	2
TD	TD		10 M Trap	16-1/2" (42 cm)	2
T2	T2		10 M Trap	17" (43 cm)	2
T4	T4		15 M Trap	19" (48 cm)	2

### Limited Warranty

Cushcraft Corporation, 48 Perimeter Road, Manchester, New Hampshire 03103, warrants to the original consumer purchaser for one year from date of purchase that each Cushcraft antenna is free of defects in material or workmanship. If, in the judgement of Cushcraft, any such antenna is defective, then Cushcraft will, at its option, repair or replace the antenna at its expense within thirty days of the date the antenna is returned (at purchaser's expense) to Cushcraft or one of its authorized representatives. This warranty is in lieu of all other expressed warranties. Any implied warranty is limited in duration to one year.

Cushcraft Corporation shall not be liable for any incidental or consequential damages which may result from a defect. Some states do not allow a limitation on how long an implied warranty lasts or exclusions or limitations of incidental or consequential damages, so the above limitation and exclusion may not apply to you. This warranty gives you specific legal rights, and you may also have other rights which vary from state to state. This warranty does not extend to any products which have been subject to misuse, neglect, accident or improper installation. Any repairs or alterations outside of the Cushcraft factory will nullify this warranty.

# TA5FA

# Figure 6

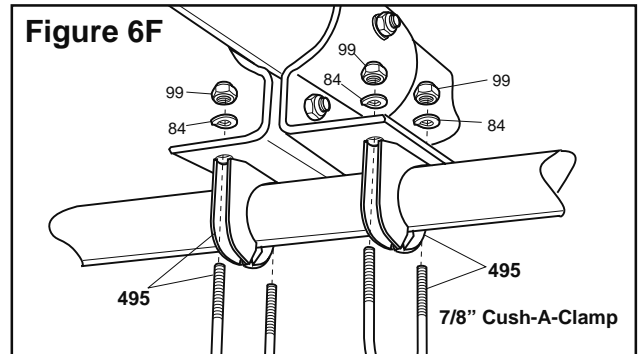
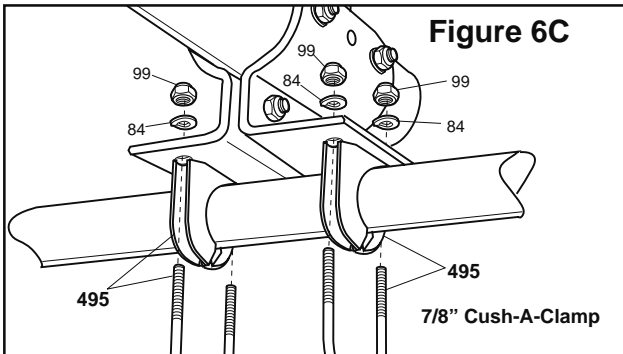
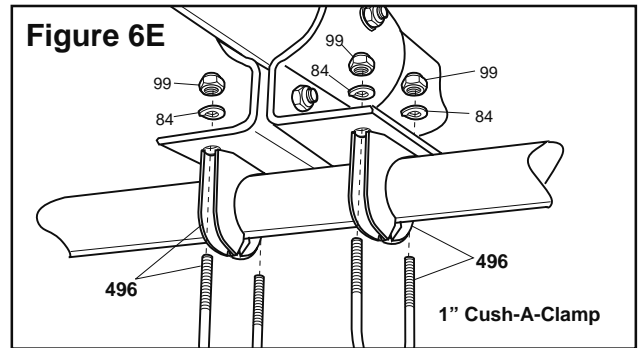
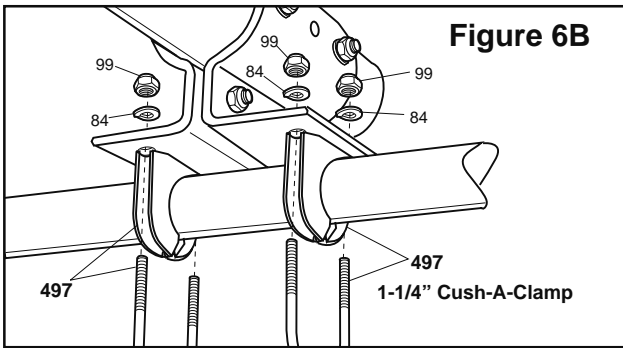
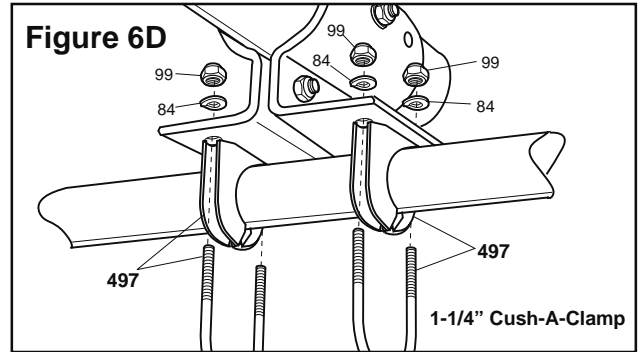
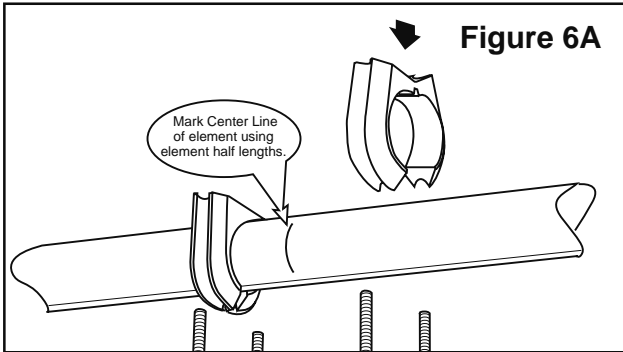
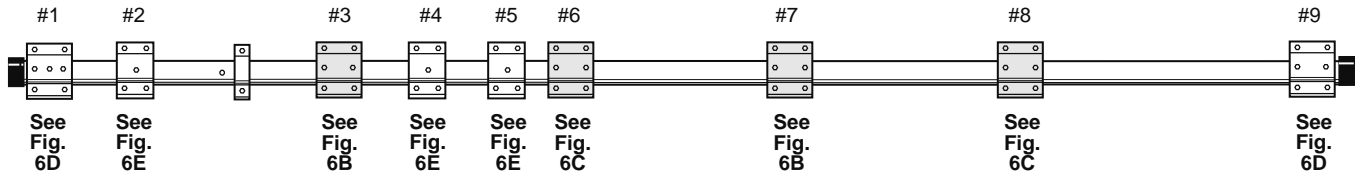

## 4-Element to Boom Assembly

Elements can be attached to the boom when the antenna is on the ground or when the antenna is being installed on a tower. Identify the hardware required to secure the elements by using the Element-to-Boom Parts List. Figure 6 shows the position of each element on the boom. Mark the center of element as shown in Figure 6A. Figures 6B, 6C, 6D, 6E, 6F show the hardware required to attach each element to the element bracket. Position each element center mark equidistant between each Cush-A-Clamp. Leave the Cush-A-Clamps loose on the Log Cell Elements (#3, #4, #5, #6) until the feed straps are attached in Step 5. There are three sizes of Cush-A-Clamps. Tighten each clamp until the element tubing can no longer rotate inside the Cush-A-Clamp. The lock washers under the nuts securing the Cush-A-Clamps should be tightened until they are flat against the mounting bracket.

ID	Part #	Description	Dimensions	Qty
84	010084	SS Lock Washer	1/4" (.6 cm)	36
99	014399	SS Lock Nut	1/4" (.6 cm)	36
495	014495	Cush-a-Clamp®	7/8" (2.2 cm)	6
496	014496	Cush-a-Clamp®	1" (2.5 cm)	4
497	014497	Cush-a-Clamp®	1-1/4" (3.2 cm)	8

TA5FA



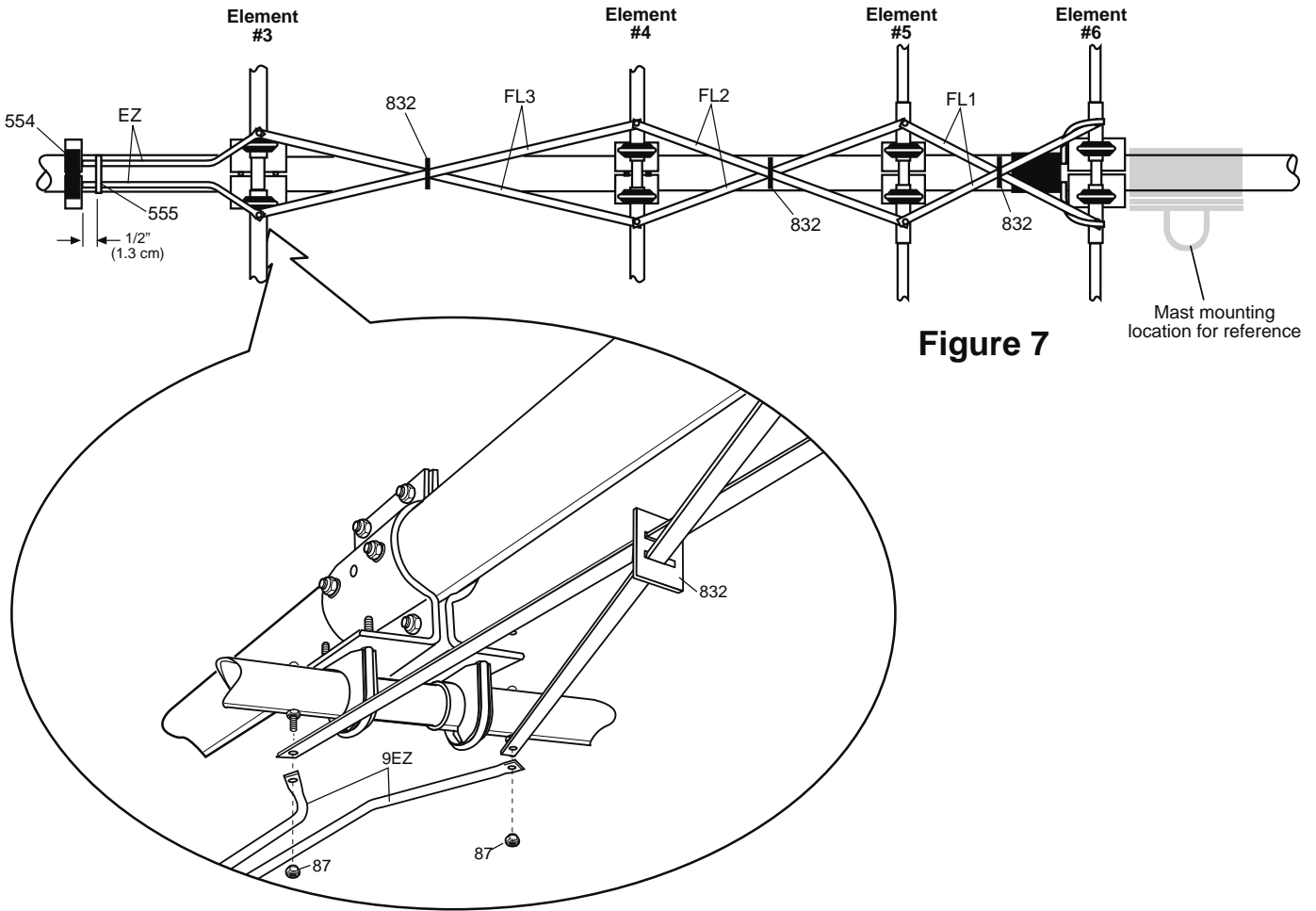

**Figure 7**









Mast mounting location for reference

## 5-Feed System Assembly

The feed system consists of 3 sub-assemblies. They are the feed-straps, the tuning tube insulator and the matching network. Figure 7 illustrates the 3 pairs of feed-straps (FL1, FL2, FL3). Refer to the Feed System Subassembly Parts List for the hardware required to install the straps. Slide a feed-strap insulator (832) on to each pair of feed-straps to space and insulate the straps. Elements may be rotated slightly during feed strap attachment. Tighten Cush-A-Clamps on Elements #3, #4, #5 and #6.

Locate the 2 tuning-tubes (EZ). Attach the punched ends of each tube to the screws at the center of Element #3.

Locate the Tuning Tube Shorting Strap (555). Loosen the 2 screws and slide the strap onto the tuning tubes (EZ). Leave strap loose.

ID	Part #		Description	Dimensions	Qty
87	014387		SS Lock Nut	#8-32	8
554	154554		Tuning Tube Insulator	3" x 2-1/2" x 1" (7.6 x 6.3 x 2.5 cm)	1
555	194555		Tuning Tube Shorting Strap	2-7/8" x 1" x 1/4" (7.3 x 2.5 x .6 cm)	1
832	323832		Strap Insulator	2" x 1-1/2" x 1/8" (5.1 x 3.8 x .3 cm)	3
FL1	X79FL1		Feedline Strap	5/8" x 16" (.9 x 41 c m)	2
FL2	X79FL2		Feedline Strap	5/8" x 20-3/4" (.9 x 53)	2
FL3	X79FL3		Feedline Strap	5/8" x 28-3/4" (.9 x 73 cm)	2
EZ	X79EZ		Bent Alum Tube	3/8" x 28" (.95 x 71.1 cm)	2





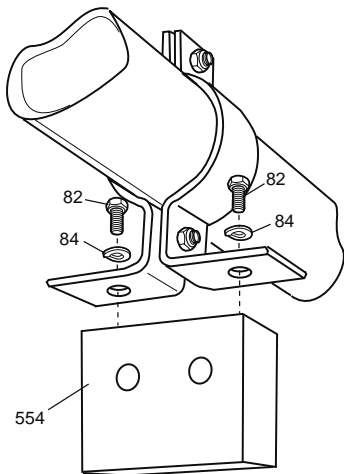

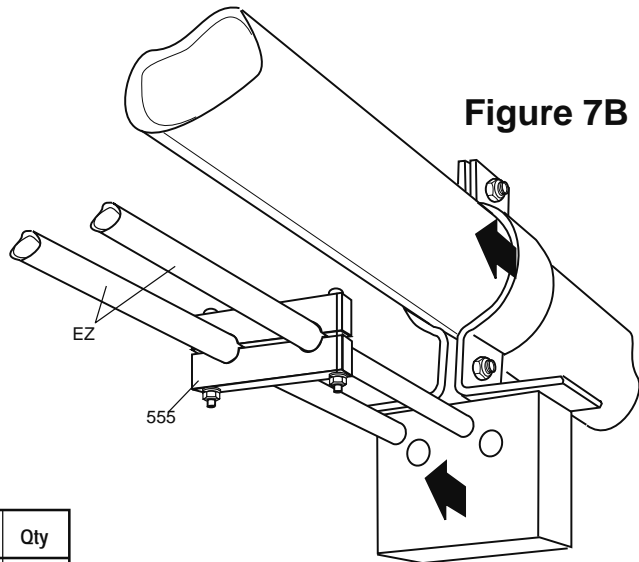

TA5FA

**Figure 7A**

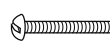

**Figure 7B**

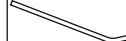
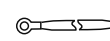

ID	Part #		Description	Dimensions	Qty
82	010082		Hex Bolt	1/4-20 x 1" (.6-20 x 2.5 cm)	2
84	010084		SS Lock Washer	1/4" (.6 cm)	2
87	014387		SS Lock Nut	#8-32	2
554	154554		Tuning Tube Insulator	3" x 2-1/2" x 1" (7.6 x 6.3 x 2.5 cm)	1
555	194555		Tuning Tube Shorting Strap	2" x 1-1/2" x 1/8" (5.1 x 3.8 x .3 cm)	1
597	014597		SS Machine Screw	#8-32 x 3" (7.6 cm)	2
941	011941		SS Lock Washer	#8	4
EZ			Tuning Tube	3/8" x 30" (.95 x 76.2 cm)	2
FS	X79FS		Feed	6" (15.2 cm)	2
MN	MNX79		Matching Network		1

Refer to Figure 7A and attach the tuning tube insulator to the boom bracket. Use the hardware listed in the Tuning Tube Insulator Subassembly Parts List. Slide the insulator toward tuning tubes (EZ) until tube ends slide into the insulator holes, (Figure 7B). Tighten bolts on boom bracket securing tuning tube insulator in place.

Reference Figure 7 and position the Tuning Tube Shorting Strap (555) 1/2 inch from the tuning tube insulator. Adjusting this strap will not have a significant effect on the VSWR of the X9. Tighten strap screws.

Reference Figure 7C for matching network mounting. Required hardware is listed in the Matching Network Subassembly Parts List. Attach matching network (MN) to boom with two 8-32 bolts (597). Connect feed straps (FS) from matching network terminals to each FL3 end at the center of Element #6. Form drip loops in the feed straps and position them as shown in Figure 7C. Form the feed-straps away from the Cush-A-Clamp U-bolts and Element #6 element bracket.

**Figure 7C**

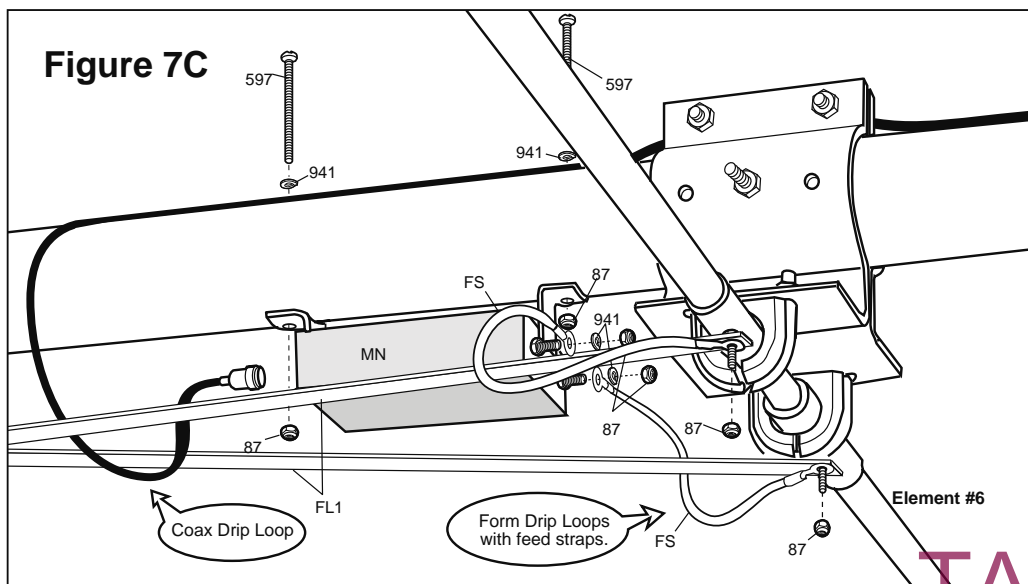

**Figure 8**

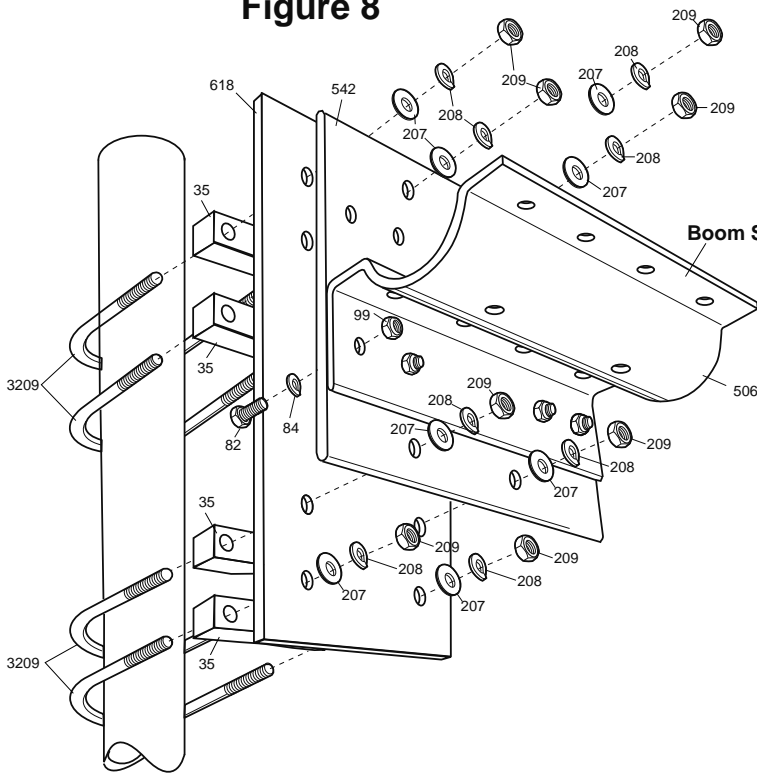

**Figure 8A**

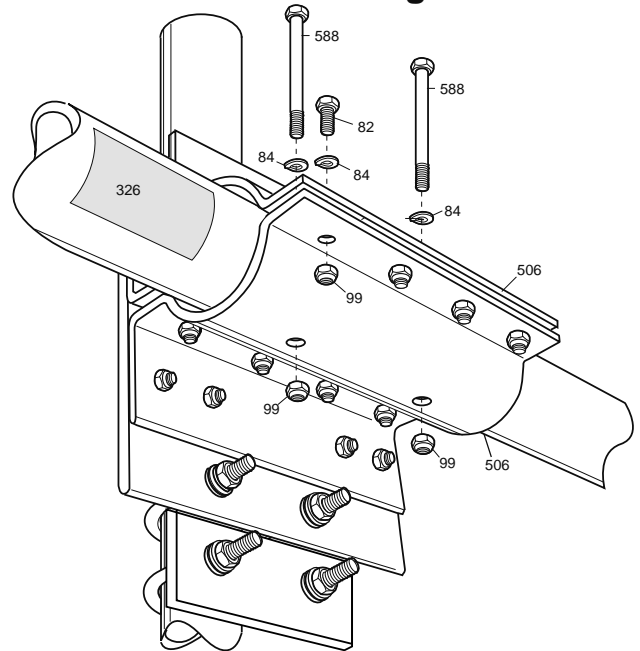

ID	Part #		Description	Dimensions	Qty
35	170035		Aluminum V-Block	2-1/2" (6.3 cm)	4
82	010082		Hex Bolt	1/4-20 x 1" (2.5 cm)	16
84	010084		SS Lock Washer	1/4" (0.6 cm)	18
99	014399		SS Lock Nut	1/4" (.6 cm)	18
207	010207		SS Flat Washer	3/8" (.95 cm)	8
208	010208		SS Lock Washer	3/8" (.95 cm)	8
209	010209		SS Nut	3/8" (.95 cm)	8
326	290326		Danger Label		1
506	324506		Aluminum Bracket	8" x 5-1/4" x 3/16" (20.3 x 13.3 x .5 cm)	2
542	194542		Alu Mounting Plate	8" x 8" x 1/4" (20.3 x 20.3 x .6 cm)	1
588	014588		SS Hex Bolt	1/4" x 3-1/2" (.6 x 8.9 cm)	2
618	194618		Alu Mounting Plate	6" x 12" x 1/4" (15.2 x 30.5 x .6 cm)	1
3209	013209		U-Bolt	2-7/8" (7.3 cm)	4

## 6-Boom to Mast Clamp Assembly

The X9 boom to mast clamp is designed to be mounted on the tower/mast so the built in boom shelf feature can be utilized. Following this suggestion, if possible, will simplify antenna installation.

Reference Figure 8 for assembly of boom to mast clamp. Required hardware is listed in the Boom to Mast Clamp Assembly Parts List. Form the boom shelf by attaching the lower boom bracket (506) to the mast plate (542). Attach mast plates (542 & 618) to mast using U-bolts (3209) and V-blocks (35).

Place the boom on the boom shelf during installation. Loosely attach the top boom bracket (506) to the mast-plate (542) and to the lower boom bracket (506) as shown in Figure 8A. This allows the boom to be moved back and forth for tower top element mounting.

When all elements are securely mounted to the boom and the feed system is in place, line up the 2 holes in the top of the upper boom bracket (506) holes with the corresponding 2 holes in boom section BC. Insert bolts (588) and tighten in place. Next, tighten the 8 bolts, securing the upper and lower boom brackets. Tighten the 4 bolts connecting the upper boom bracket to the mast plate.

Attach good quality coax with a PL-259 connector to the X9 matching network. Route the coax as shown in Figure 7C. Form a drip-loop with the coax and secure the coax to the boom. Insure PL-259 connector is waterproofed with a good quality sealant after it is attached to the matching network.

**TA5FA**

# 7 - Boom Truss Assembly

Figure 9 illustrates the boom truss assembly. Refer to the boom truss assembly parts list for the hardware required. The X9 uses Phillystran® cable to guy the boom. The cable is one continuous piece from one boom end to the other. Note the Phillystran cable safety loop that goes around the mast truss bracket.

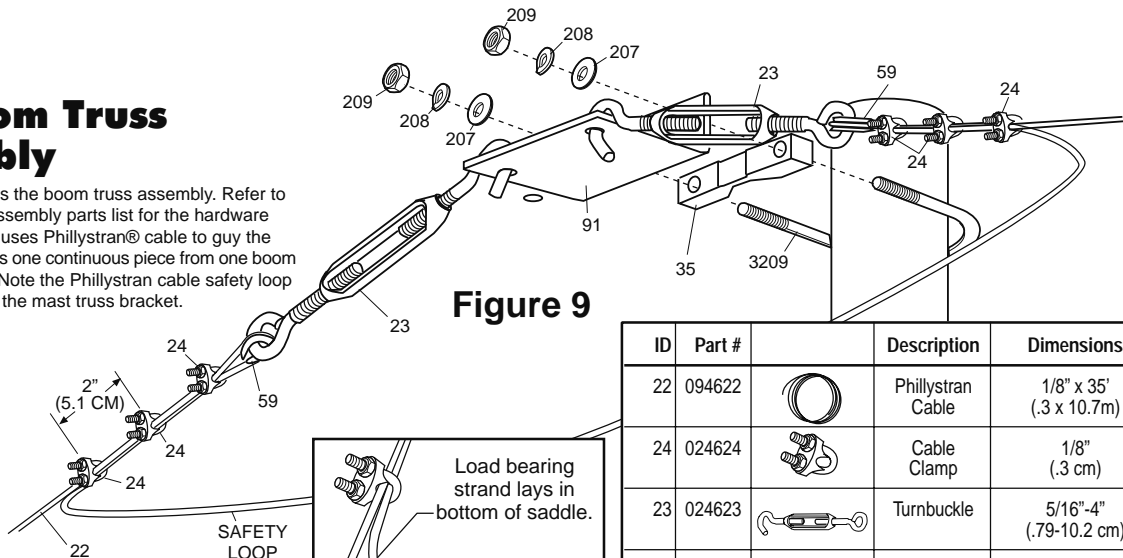

**Figure 9**

ID	Part #		Description	Dimensions	Qty
22	094622		Phillystran Cable	1/8" x 35' (.3 x 10.7m)	1
24	024624		Cable Clamp	1/8" (.3 cm)	12
23	024623		Turnbuckle	5/16"-4" (.79-10.2 cm)	2
91	194791		Truss Bracket	2" x 42" x 1/8" (5.1 x 10.2 x .3 cm)	1
35	170035		Aluminum V-Block	2-1/2" (6.3 cm)	1
59	024259		Thimble	1/8" (.3 cm)	4
207	010207		SS Flat Washer	3/8" (.95 cm)	2
208	010208		SS Lock Washer	3/8" (.95 cm)	2
209	010209		SS Nut	3/8" (.95 cm)	2
3209	013209		U-Bolt	2-7/8" (7.3 cm)	1

Attach the truss plate (26) to the mast 3 feet (1m) above the boom to mast clamp using the 3/8" hardware provided. Position the truss bracket on the same side of the mast as the boom to mast clamp. Unscrew the turnbuckle ends until there is 1/2" (1.2 cm) of thread remaining. Place the jaw of each turnbuckle (23) into the holes of the truss bracket. Place a thimble (59) on the eye of each turnbuckle. Place three loose cable clamps (24) onto the cable end. Reference Figure 9 and place the cable clamp saddle over the load bearing cable. The load bearing cable is the cable that attaches to the boom end. Feed the cable through a turnbuckle eye. Run the cable back through the cable clamps. Place three additional cable clamps on the end of the cable. Feed the cable through the other turnbuckle eye. Run the cable back through the cable clamps. Feed enough cable through these parts until the center of the Phillystran cable coil is located at the truss bracket. Insure there is enough slack in the cable to form a loose safety loop between the turnbuckles. Tighten the cable clamps beginning with the clamp closest to the thimble.

Refer to Figure 4B for attachment of the cable to the boom ends. Place a thimble (59) on the 1/4-20 x 1" bolt. Place three loose cable clamps (24) onto the cable end. Feed the cable end through the element bracket and around the thimble. Run the cable back through the cable clamps. Tighten the cable to remove the majority of the sag from the boom. Space the cable clamps 2 inches (5.1 cm) apart. Insure the load bearing cable is seated in the cable clamp saddle as shown above. Tighten the cable clamps beginning with the clamp closest to the thimble. Cut off excess cable 2" (5.1 cm) after the third cable clamp.

Adjust each turnbuckle to bring each boom end level with the center. Phillystran cable has a minimal amount of stretch over time. A safety wire can be placed through the turnbuckle openings to keep the turnbuckles from unscrewing.

## Tuning Procedure

The X9 does not require tuning. The broadband VSWR characteristics of the log cell can not be improved by adjusting element lengths. Varying the element dimensions from those suggested in this manual is not recommended. For help with tuning, please contact Cushcraft technical support.

## SPECIFICATIONS

Frequency Coverage (Meters)	10, 15, 20	Longest Element, ft (m)	36.5 (11.12)
Total number of Elements	9	Turning Radius, ft (m)	21.7 (6.61)
Maximum Gain (dBi)	20M 13.0 @ 14 deg	Boom Length, ft (m)	28 (8.53)
@ One Wavelength	15M 13.9 @ 12 deg	Boom Diameter, in (cm)	2-1/2 (6.35)
above ground	10M 14.0 @ 15 deg	Maximum Mast Diameter OD, in (cm)	2-1/2 (6.35)
Free Space Gain (dBi)	20M 8.25	Maximum Wind Survival, mph (kph)	>100 (>161)
	15M 9.75	Maximum Wind Surface Area, ft <sup>2</sup> (m <sup>2</sup> )	9.9 (.92)
	10M 9.75	Windload @ 80 mph, lb (kg)	255 (116)
Maximum Front to Back Ratio (dB)	30	Maximum Power Handling (KW)	2
Number of Elements per Band	4*	Weight, lb. (kg)	85 (38.5)
VSWR Minimum	1.1:1	Design Safety Factor	1.25
VSWR 1.5:1 Bandwidth (KHz)	20M 350		
	15M 450		
	10M 1500		

\* 6 active elements on 10 meters



**CUSHCRAFT**  
COMMUNICATIONS ANTENNAS

**TA5FA**