

EFRATOM LPRO-101
Repair reference guide
By Fred de Vries, PE1FBO, 2010

Revision 6, Januari 2010, © PE1FBO

Contents

Brief specs	4
Rubidium lamp.....	4
Temperature controlled assemblies.....	5
17 and 14 Volts section	6
5 volts filtering.....	7
VCO and input protection diodes.....	8
VCO section (20MHz).....	8
Rb cell connections (SRD and C-field)	9
SRD (Step Recovery Diode).....	9
Rb cell connections (Thermistor and Photocell).....	10
C field adjustments	11
Possible faults on the unit.....	12
Location of R705 and R729	13
Note on replacement of the Rb cell heater transistors	13
Tantalum caps	13
SMD diode reference.....	14
SMD diode reference by SMD code	14
SMD transistor reference by SMD code	14
SMD IC reference	14
Tuning the unit.....	15
Efratom Rubidium synthesizer schema	17
Hyperfine resonance frequencies according to NIST.....	17
Lamp exciter diagram	18
Lamp heater diagram sub 1	19
Lamp heater diagram sub 2.....	20

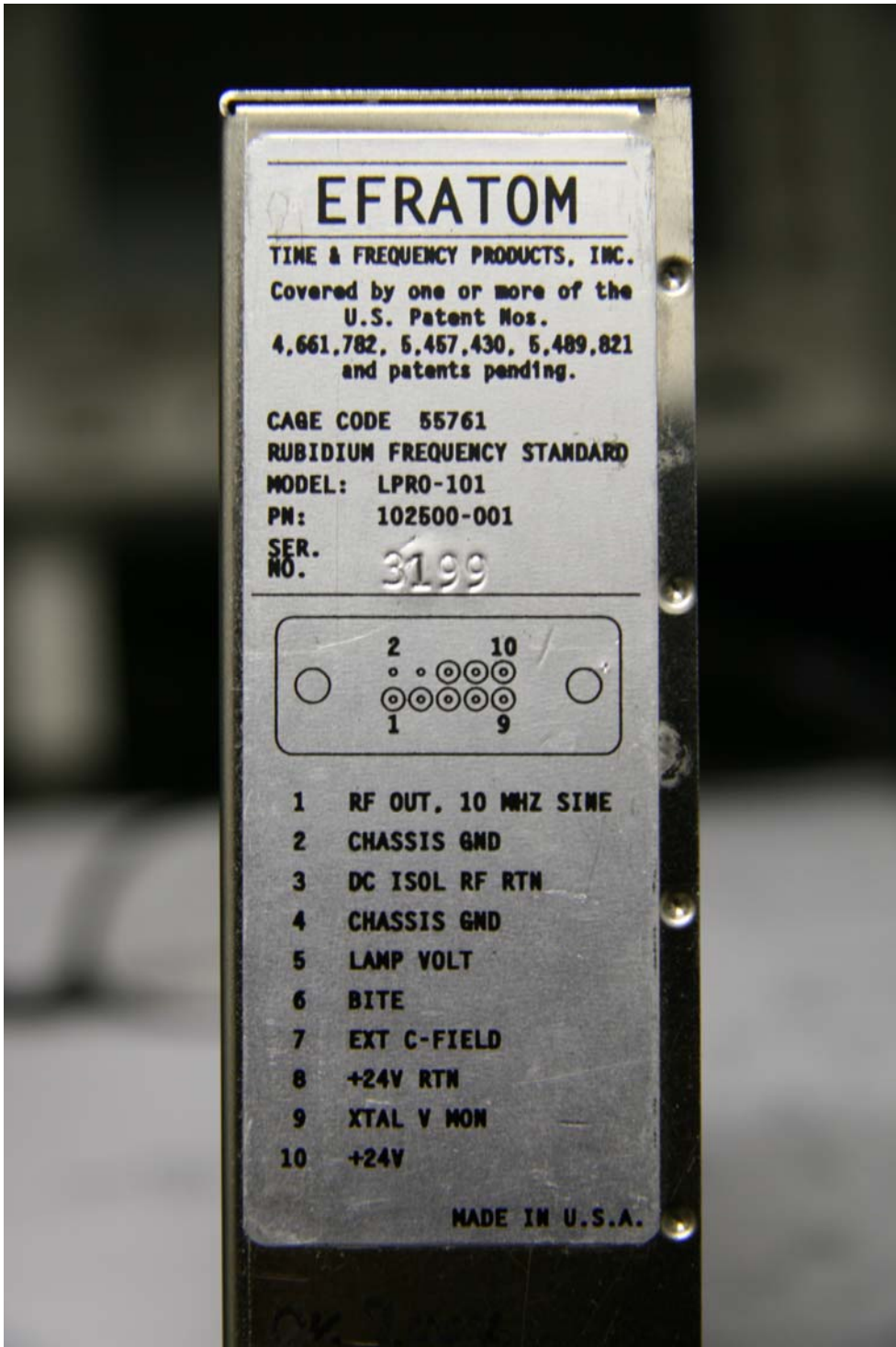

Fig 1, Connections

Brief specs

Nominal input voltage 24 V DC. (19 .. 32V)

Initial input current when cold (22°C) is about 1.25 Amp, when the lamp ignites it becomes 1.19 Amps.

Input current when locked is 0.35 .. 0.45 Amp

Time to lock when cold (22°C) is 3 to 5 minutes

Rubidium lamp

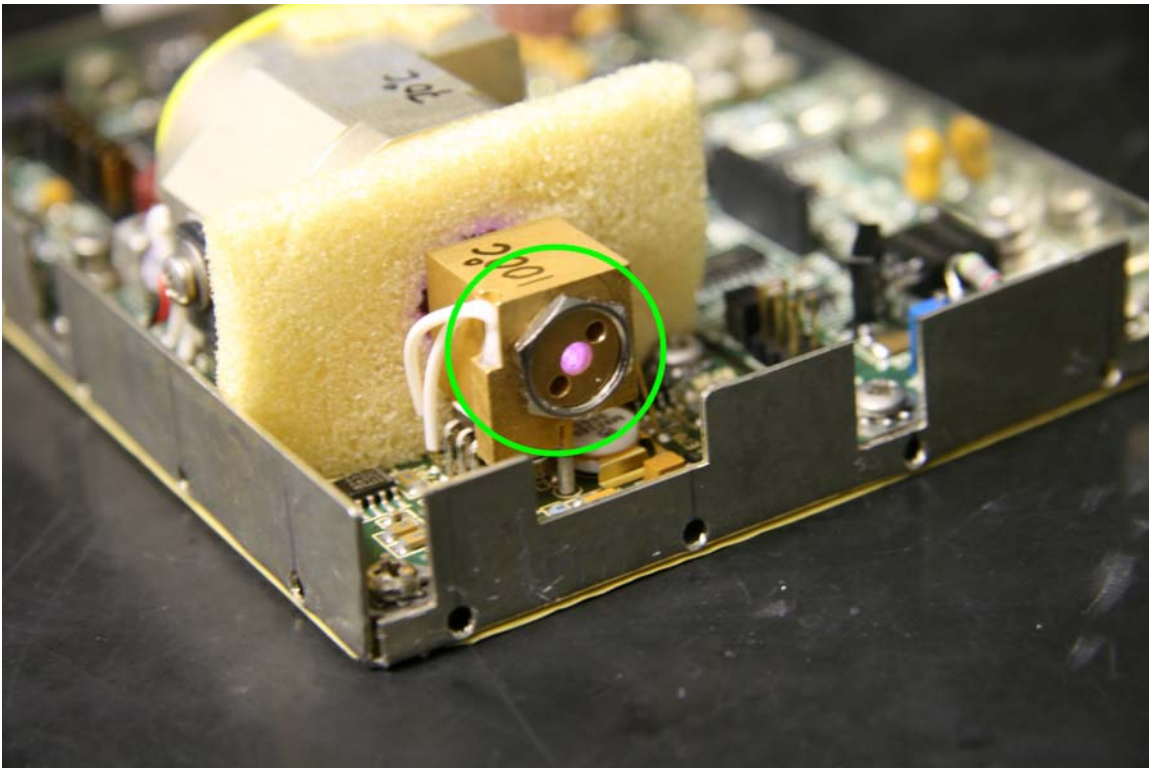

Fig 2, Rubidium lamp

When the rubidium lamp section reaches 40 to 60° Celsius it ignites, you will see the purple light coming from the back of the lamp.

Mind you, that when stray light (50Hz or 60Hz) enters the rubidium cell, the whole unit starts to behave very strange and loses lock, so be aware of this!

Lamp voltage (pin 5) can be as low as 3 Volts, below 3 volts an atomic lock becomes difficult. Healthy units are ranging from **6 to 9 Volts**.

Temperature controlled assemblies

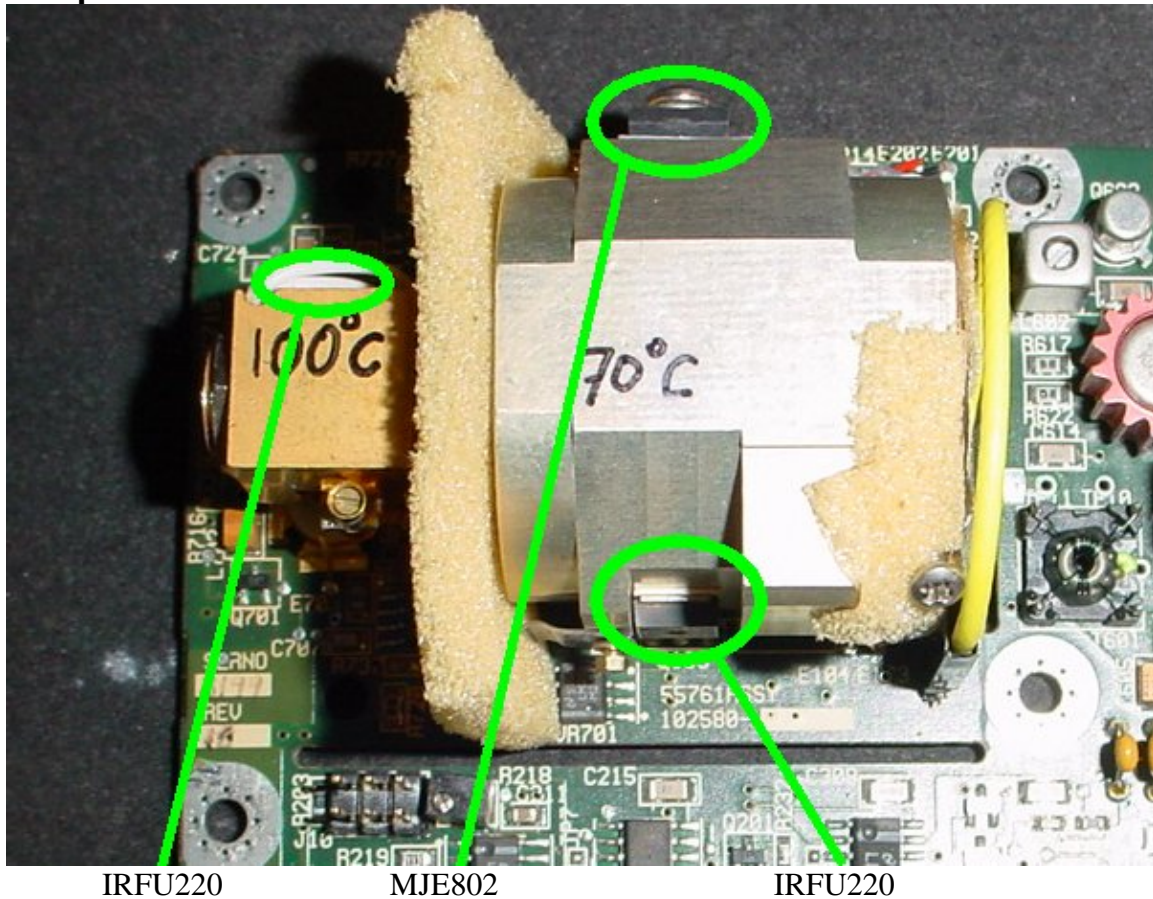

Fig 3, Temperature controlled assembly

The Rubidium lamp housing is about 101° Celsius

The Rubidium cell is about 71° Celsius

The official temperatures (according to the manual) are 110° C for the lamp, and 79° C for the Rb cell.

The housing of the heated assemblies measures lower. Both samples had this. It is also depending where you measure the temperature.

The base plate needs to be mounted on a heat sink to prevent loss of lock and thermal runaway of the internal electronics.

As a test, you can operate the unit without heat-sink for about half an hour to check if the electronics work reliable at higher ambient temperatures.

The TO202 heater transistor is a MJE802 (NPN darlington, 4A, 40Watt), this can be replaced with an BD679 or BD681.

The TO251 transistors on the lamp and Rb-cell are IRFU220 MOSFETS, 4.6A/200V, 40 Watt. They can be replaced with an IRFU420 or STD3NB30

The Rb lamp exciter transistor is an MRF160, it's a MOSFET from Motorola. Ft 500 Mhz, 4W, 28 volts. A possible substitute could be the PD57006 from ST

17 and 14 Volts section

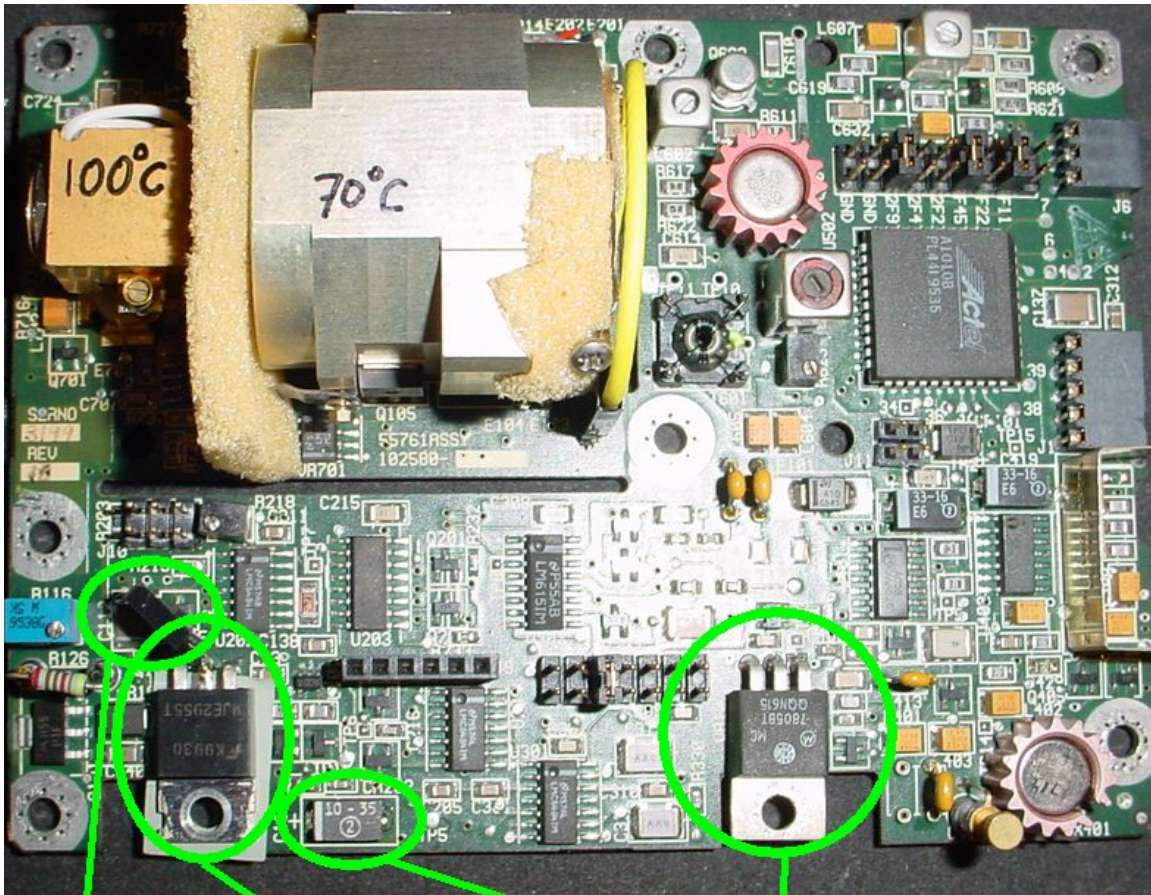

Ceramic C 2N6490 4u7/35V 7805

Fig 4, 17 Volts section and 14 Volts section

Power transistor Q106 is originally a 2N6490, it is a 15Amp, PNP, low hfe type. It can be replaced by an MJE2955T or BD912 if faulty.

The collector (mounting tab) of Q106 should be at 17.0 Volts (to GND)
Q106 is isolated from the chassis.

The additional black capacitor is 1uF/50Volts ceramic. I had to remove the one on the back side, which was suspected to be short at higher temps. There is not enough clearance on the back side of the PCB to have it fitted there.

The capacitor C116 is a tantalum one, 4.7uF/35V

The positive terminal of this capacitor is about 14.4 Volts (to GND)

The voltage regulator VR102 is an 7805, it's output is at 5 Volts (to GND)

5 volts filtering



Fig 5, 5 Volts filtering

The two SMD tantalum capacitors can be replaced by SMD tantalum ones of a different value.

The original ones were 68 μ F/16Volts. The new ones I used are 33 μ F/16 Volts.

The positive terminal of C419 is about 4.6 Volts, the other cap's voltage is about 4.4 Volts (to GND)

Both are used to filter the 5 Volts supply.

VCO and input protection diodes

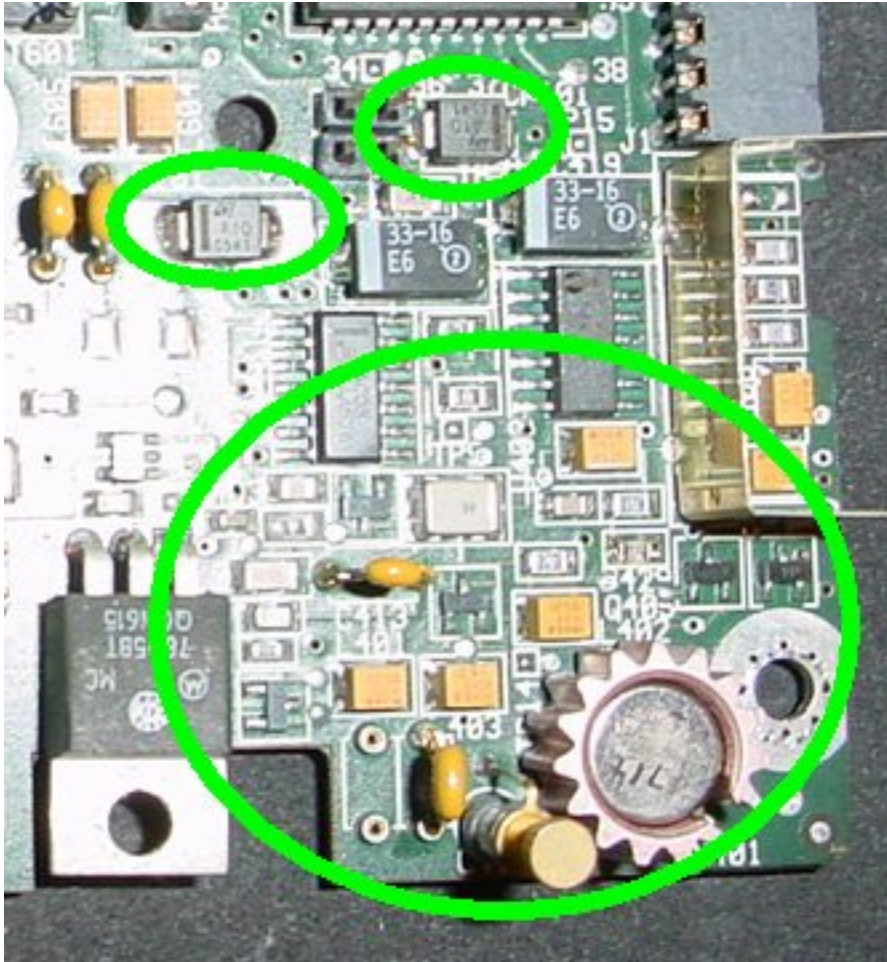

Fig 6, input protection diodes and VCO

Both diodes CR101 and CR 106 (F101) are SMBYW02 diodes, with a forward voltage drop of 650 mV.

Both anodes are connected to the input of 24 Volts, the cathode is 23.35 Volts.

VCO section (20MHz)

Oscillator VCO range is rather big +/- 150 Hz for the 10Mhz output.

9.999 850 .. 10.000 180 Hz

Total time for a complete scan takes about 105 seconds. (60s ramp up, 45s ramp down) The internal VCO works on 20MHz.

The 20 MHz crystal is housed in the round package with heat-sink on it.

Rb cell connections (SRD and C-field)

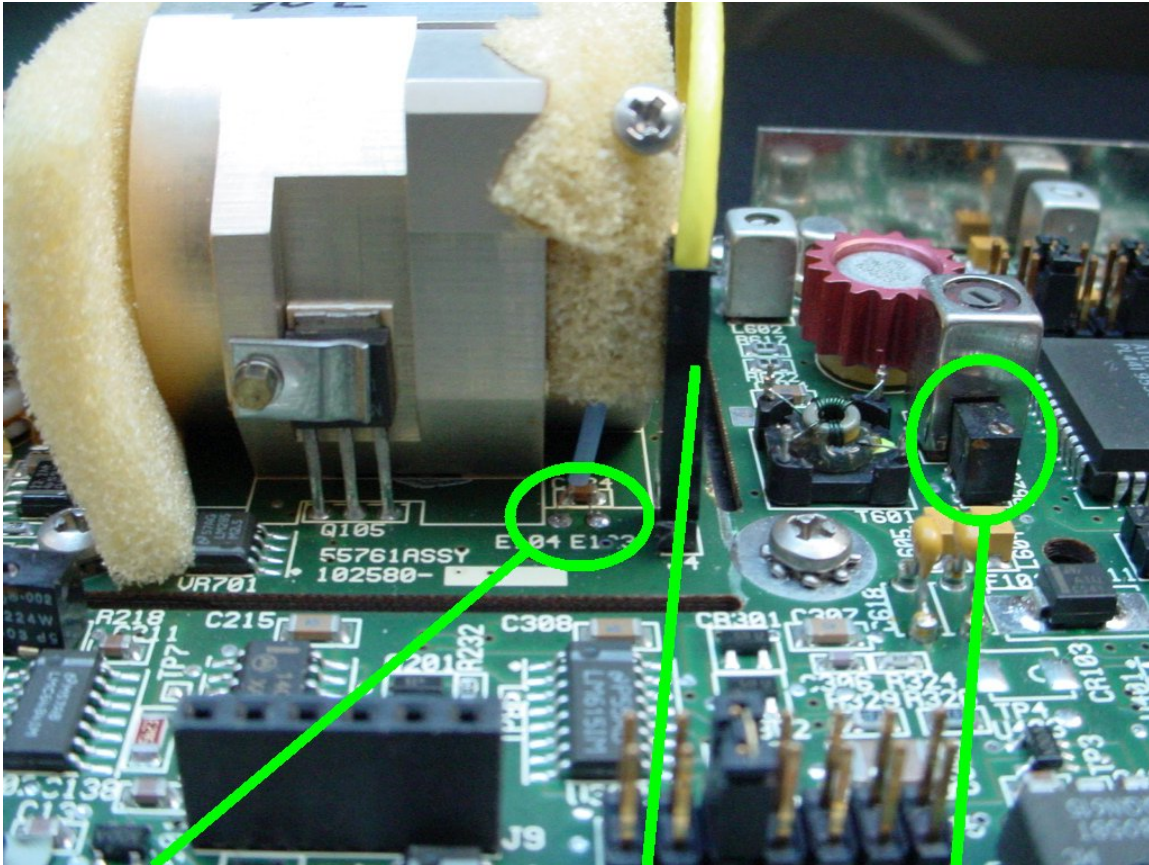

C-field coil connection

RF to cavity

SRD bias pot

Fig 7, Rb cell connections

SRD (Step Recovery Diode)

The SRD bias potentiometer is typical set between 1.5 and 4 kOhms

If you disconnect the yellow coax cable you can measure the SRD forward voltage drop of 0.7 Volts (centre to shield).

The SRD is an HP 5082-0833. It is located inside the cavity.

To set the bias correctly refer to the adjustments section.

Rb cell connections (Thermistor and Photocell)

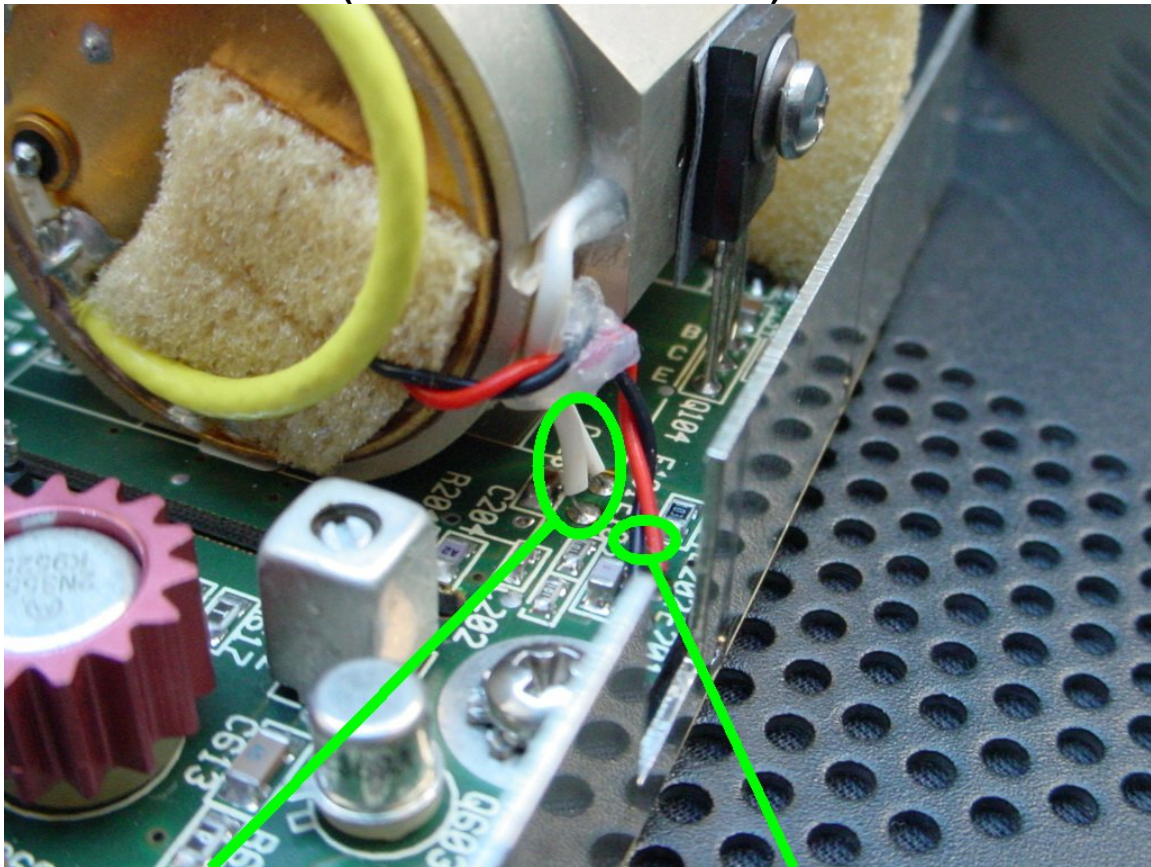

Thermistor connection

Photocell connection

Fig 8, Rb cell connections

C field adjustments

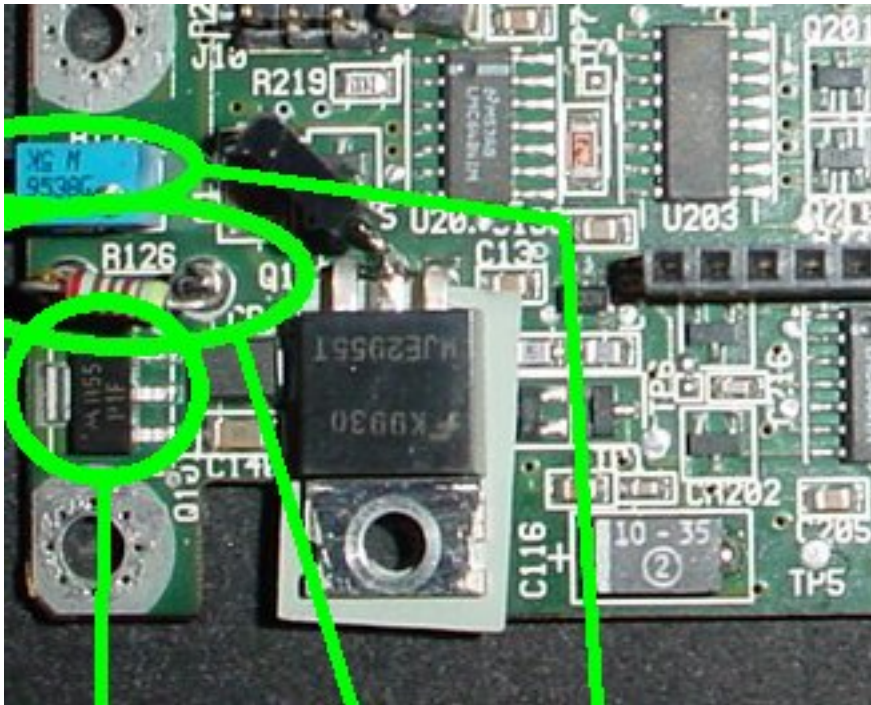

Q10, PZT2222

R126

R116

Fig 9, C field resistor

Frequency	Resistor value R126
9.999.999.908	>100k
9.999.999.964	6k2
9.999.999.976	5k2
10.000.000.002	4k2
10.000.000.050	3k2
10.000.000.165	2k2

With increasing current through the C field coil, the frequency increases.

By adapting R126, you can tune the unit with potentiometer R116 to exactly 10 MHz

The C field coil is approx. 22 Ohms, @ 70°C,
Voltage approx, 140 mV, @ 6.4mA

Q10 is a PZT2222A, P1F marking, This is a 2N2222 in SOT223 SMD package.

Possible faults on the unit.

I would say all 100k resistors of this size on the board are suspect. They are of the 0603 SMD size, and marked with 104 (The smallest parts on the board)

In particular R705 (82k in-circuit) and R729

Some quick checks can be done

- Rb lamp needs to lit
- Rb lamp housing needs to be 100°C
- Rb cell housing needs to be 70 °C

If there is a problem with the heating of the Rb cell, check if the emitter of the MJE802 is at 12 volts. This is about half the supply voltage, and follows the input voltage. The voltage over the current sense resistors (backside) is about 300mV. This is when the Rb cell is cold. There are 3 1.2Ohm resistors in parallel. Current is 850 mA. Voltage on the gate of the IRFU220 when stabilised is about 4.4 volts, on the source it is 70 mV. Drain voltage is 12 Volts.

If there is a problem with the lamp heater, you could check if the voltage over the 2 Ohms resistor (backside) is about 0.4 Volts, this corresponds to 200mA.

If the lamp does not lit, the Rb-lamp oscillator probably is dead. This is difficult to diagnose. You can start by taking out the lamp and see if it has some cracks or other physical damage. Also in a worn unit the lamp is still lit, but not so intense anymore.

Location of R705 and R729

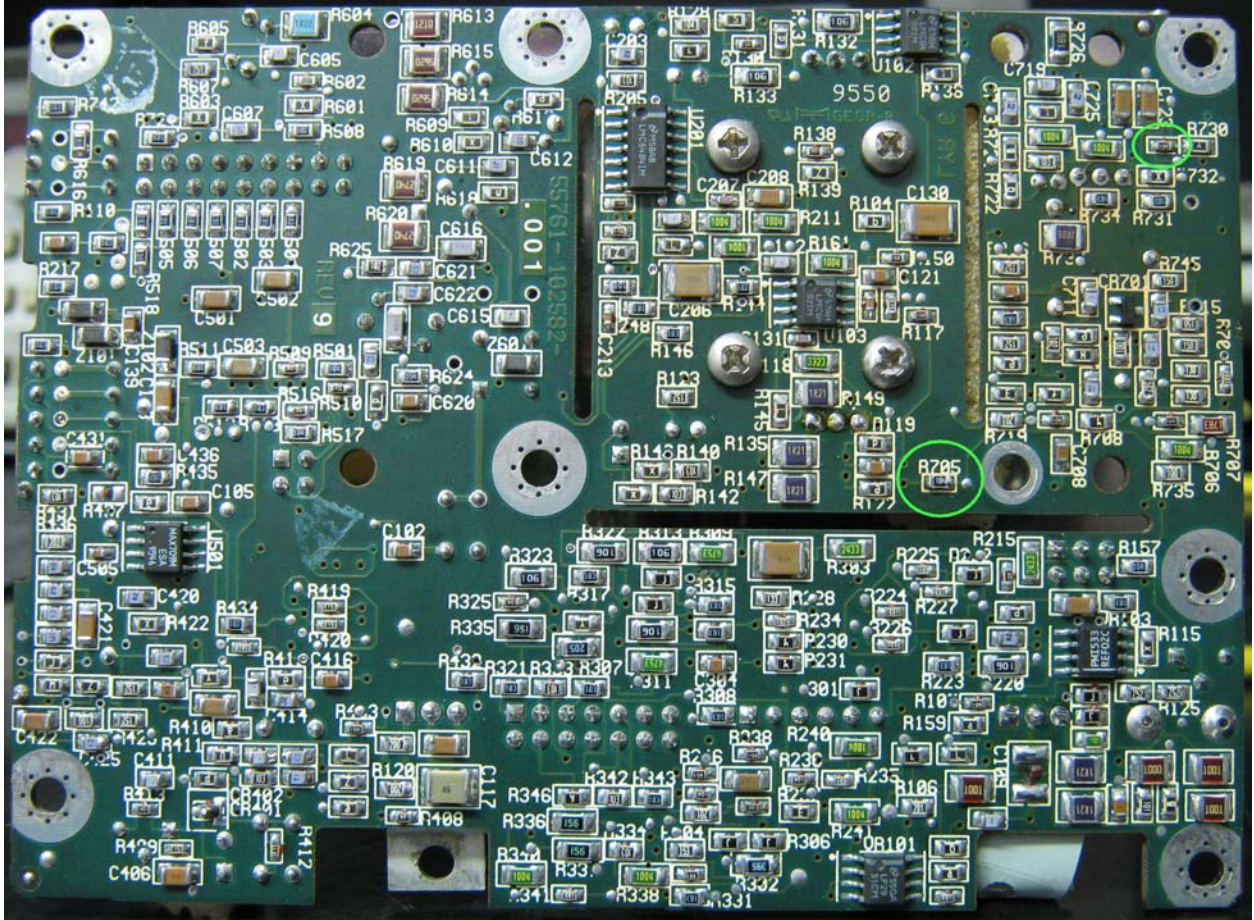

Fig 10, Location of R705 and R729

Note on replacement of the Rb cell heater transistors

Efratom has used a fusing kind of isolation pad to mount both heater transistors. This results in a very low thermal resistance from transistor case to the aluminium base. If you replace the transistors it is important to restore the original low thermal resistance. With an increased thermal resistance, the lock time increases as well and the MTBF of the unit is also negatively affected since the junction temperature of both heater transistors will be higher.

Tantalum caps

On an old unit, the tantalum caps have possibly a high ESR or are completely open. I would replace them with new ones since the units run at high temperatures and this has an accelerated aging effect on the tantalum caps.

SMD diode reference

CR101	SMBYW02-100 (BYW02)
CR106 or F101	SMBYW02-100
CR102	SMD CODE ER10 ??

SMD diode reference by SMD code

5D	MMBD914 (1N914)
----	-----------------

SMD transistor reference by SMD code

1P	MMBT2222 A
P1F	PZT2222 A
1JA	MMBT2369 A

SMD IC reference

U101	LMC7101 AIM5X	
U102	LMC6482 IM	(replacable with TLC272)
U103	LMC6482 IM	(replacable with TLC272)
U201	LMC6484 IM	(replacable with TLC274)
U202	LMC6484 IM	(replacable with TLC274)
U203	MC14053 B	
U204	LMC6484 IM	(replacable with TLC274)
U301	LMC6484 IM	(replacable with TLC274)
U302	LM615 IM	
U401	74AC08	
U402	74AC74	
U403	LMC7101 AIM5X	
U501	MAX709 M	
U701	TLC2272	
U702	TLC2272	
VR101	LP2951 CM	
VR103	REF02 C	
VR701	LM285	

Tuning the unit

Once you have a locked unit you can tune the SRD bias and the 6.8 GHz cavity. Allow the unit to warm-up for 10 minutes. You can only do this after a lock has been established. If you don't have a lock, you probably make things worse by adjusting the settings on the unit.

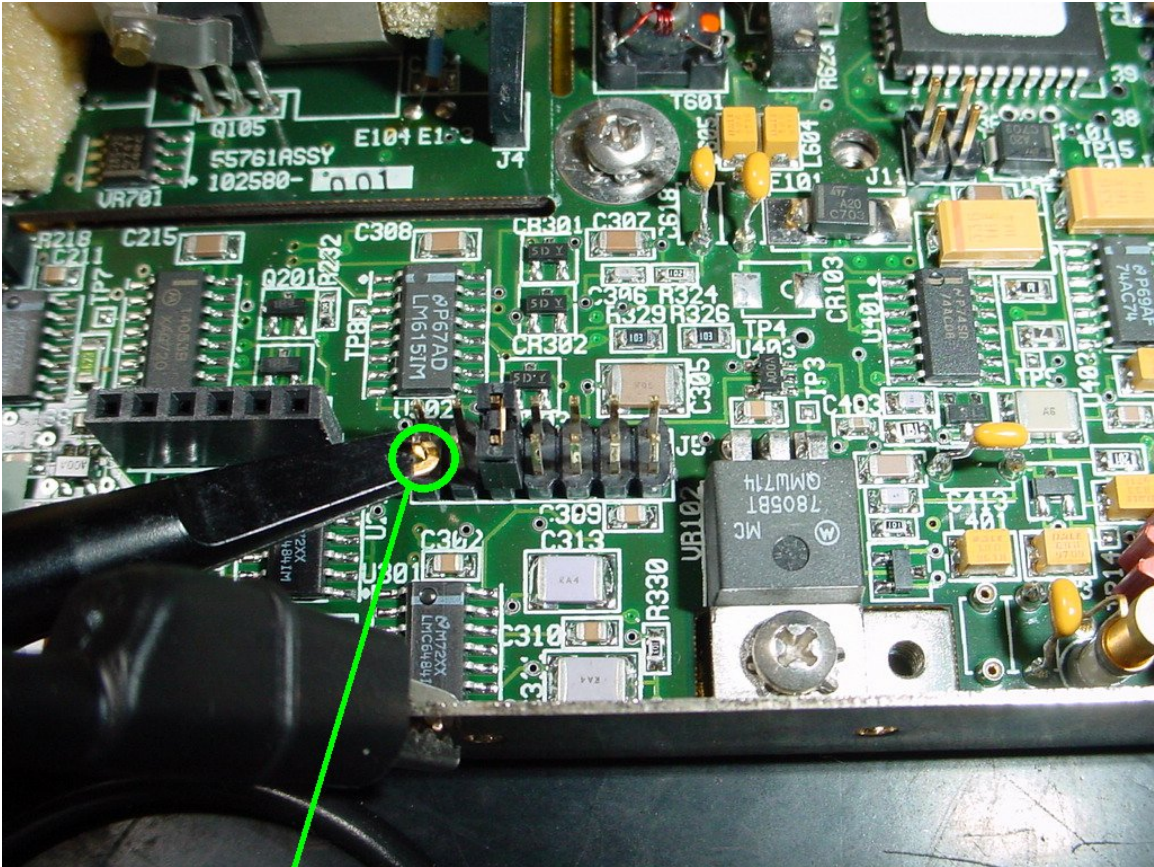

Fig 11, Test point J5, corner pin

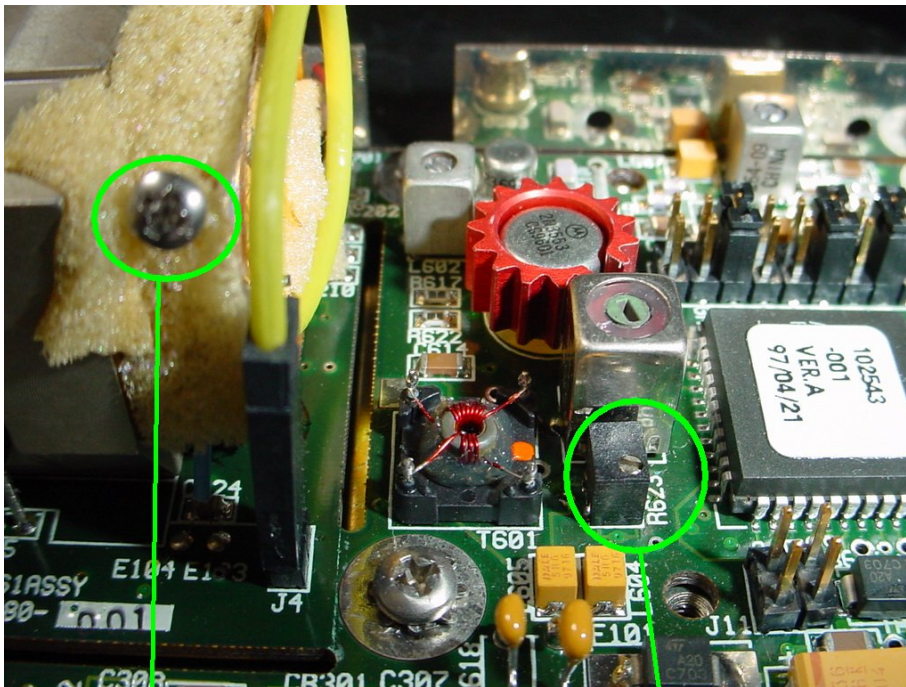

Fig 12, Cavity tuning 6.8 GHz

SRD bias pot

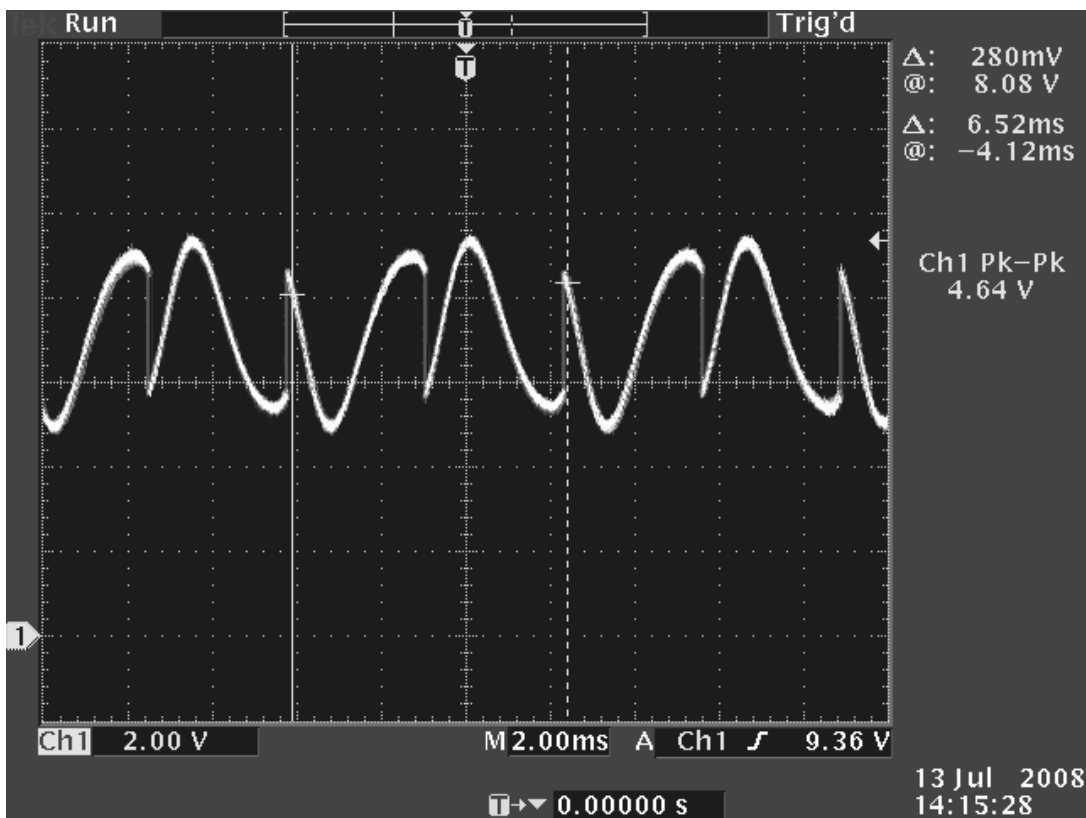

Fig 13, Wave form on J5

Tune both adjustments for maximum Vpp

Efratom Rubidium frequency synthesizer schema

A part)

$$10 \text{ MHz} * 6 = 60 \text{ MHz}$$

$$114 * 60 \text{ MHz} = 6.840 \text{ GHz}$$

B part)

$$10 \text{ MHz} / 2 = 5 \text{ MHz}$$

$$5 \text{ MHz} / 16 = 0.3125 \text{ MHz}$$

$$5 \text{ MHz XOR } 0.3125 \text{ MHz} = 5.3125 \text{ MHz}$$

A and B are mixed, one of the components is

$$6.840 - 0.0053125 = 6.834 \text{ 687 500 GHz}$$

Atomic ground state hyperfine resonance frequencies according to NIST

$$\text{Rubidium} = 6.834 \text{ 682 608 GHz}$$

$$\text{Hydrogen} = 1.420 \text{ 405 752 GHz}$$

$$\text{Caesium} = 9.192 \text{ 631 770 GHz}$$

Difference of frequency (NIST measure and Efratom synth.) is due to buffer gas in the Rb cell, that has a positive offset on the resonance frequency

Lamp exciter diagram

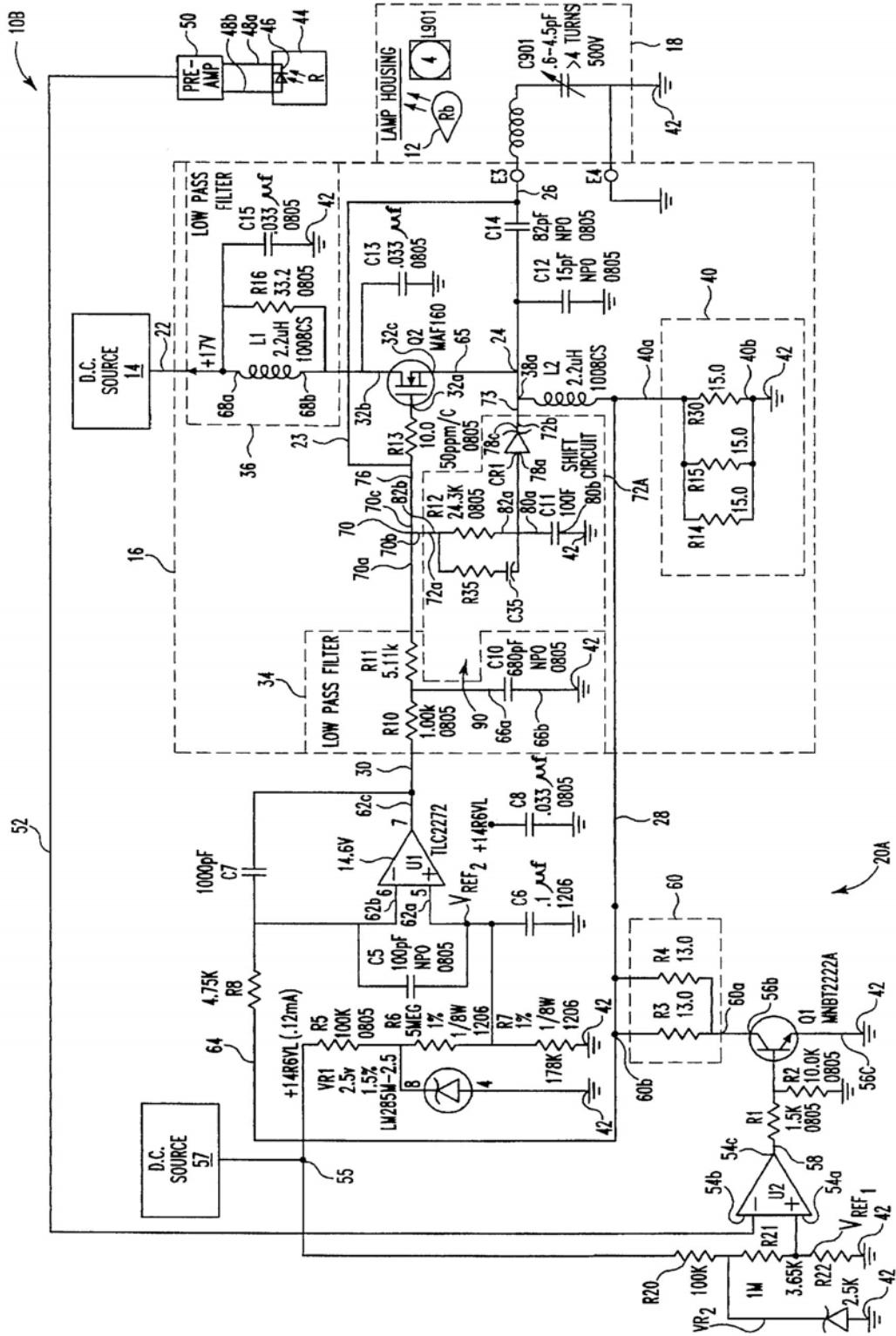

Fig 14, Diagram of Rb lamp exciter

Lamp heater diagram sub 1

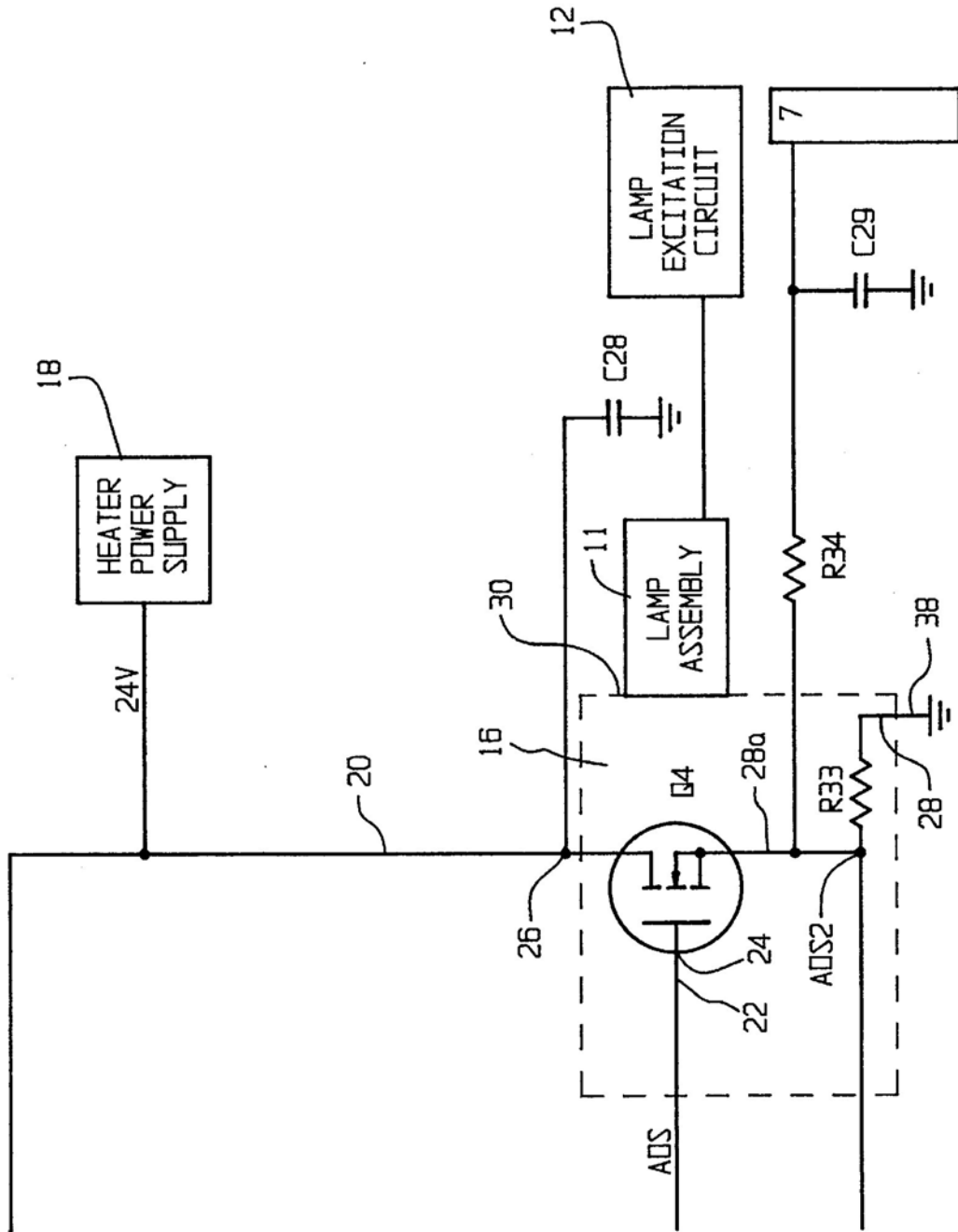

Fig 15, Lamp heater diagram sub 1

Lamp heater diagram sub 2

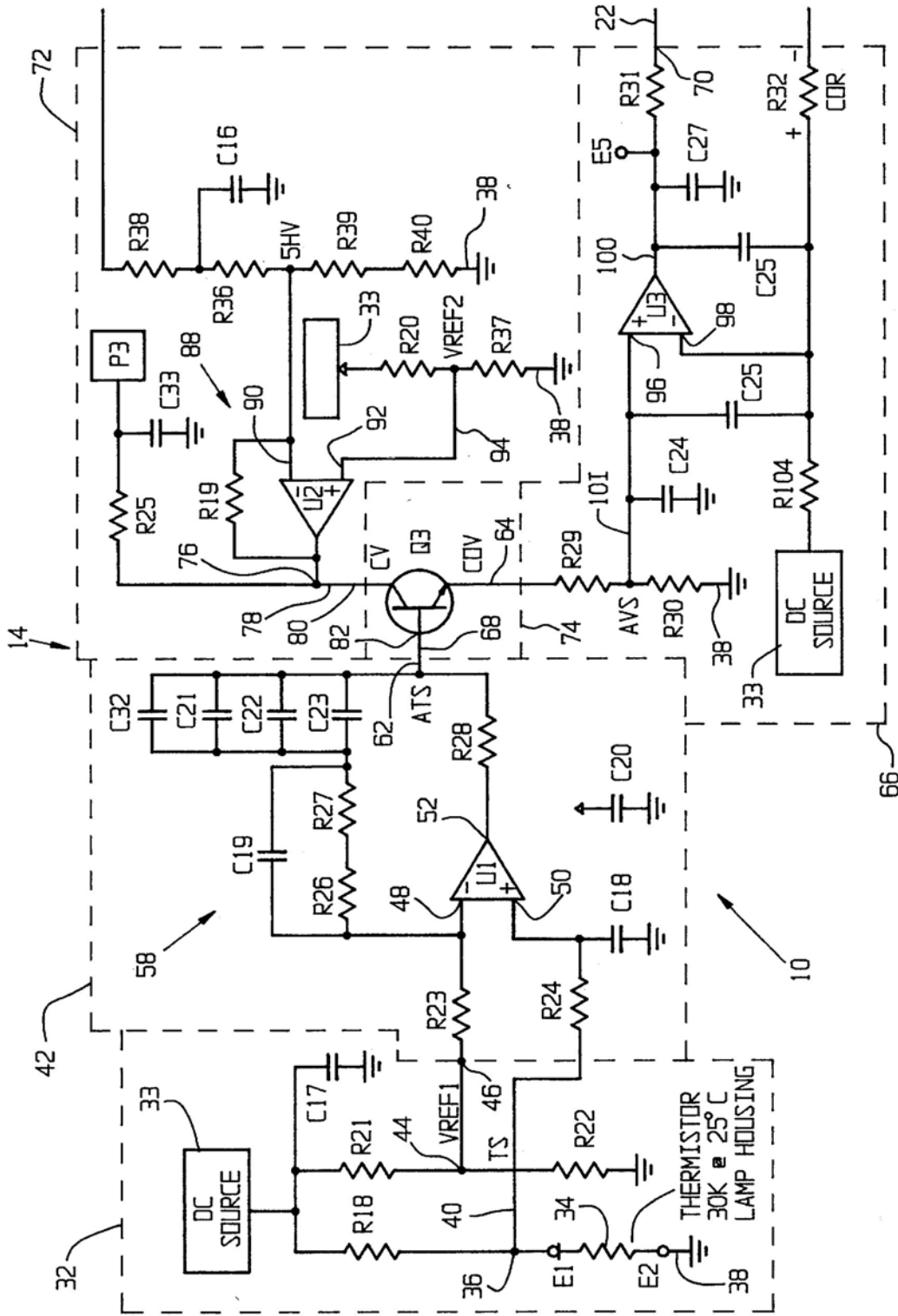

Fig 16, Lamp heater diagram sub 2