

FUJIFILM

DIGITAL CAMERA

FINEPIX

XCP140 Series

Owner's Manual

Introduction

Thank you for your purchase of this product. Be sure that you have read this manual and understood its contents before using the camera. Keep the manual where it will be read by all who use the product.

For the Latest Information

The latest versions of the manuals are available from:

<http://fujifilm-dsc.com/en/manual/>



The site can be accessed not only from your computer but also from smartphones and tablets. It also contains information on the software license.



For information on firmware updates, visit:

http://www.fujifilm.com/support/digital_cameras/software/



Chapter Index

Menu List	iv
1 Before You Begin	1
2 First Steps	13
3 Basic Photography and Playback	29
4 Movie Recording and Playback	35
5 Taking Photographs	41
6 The Shooting Menus	65
7 Playback and the Playback Menu	79
8 The Setup Menus	99
9 Shortcuts	113
10 Optional Accessories	117
11 Connections	119
12 Technical Notes	131



















Menu List

Camera menu options are listed below.

Shooting Menus

Adjust settings when shooting photos or movies.



















 See page 65 for details.

SHOOTING MENU			SHOOTING MENU		
	SHOOTING MODE	66		SELF-TIMER	70
	AF/MF SETTING	66		INTERVAL TIMER SHOOTING	71
	RELEASE TYPE	68		TIME-LAPSE MOVIE MODE	72
	ISO	68		WHITE BALANCE	73
	IMAGE SIZE	69		FLASH SET-UP	73
	IMAGE QUALITY	70		MOVIE SET-UP	74
	FINEPIX COLOR	70		IS MODE	76
				DIGITAL IMAGE STABILIZER	76
				WIRELESS COMMUNICATION	77
				INTELLIGENT DIGITAL ZOOM	78

Playback Menu

Adjust playback settings.

 See page 84 for details.

PLAYBACK MENU			PLAYBACK MENU		
	IMAGE TRANSFER ORDER	84		PROTECT	92
	WIRELESS COMMUNICATION	85		IMAGE ROTATE	92
	IMAGE SEARCH	86		RED EYE REMOVAL	93
 1	ERASE	87	 2	SLIDE SHOW	93
	MOVIE EDIT	89		PHOTOBOOK ASSIST	94
	CROP	91		PC AUTO SAVE	95
	RESIZE	91		COPY	96
				PRINT ORDER (DPOF)	97
			 3	instax PRINTER PRINT	98
				DISP ASPECT	98

Setup Menu

Adjust basic camera settings.

 See page 99 for details.















SET-UP			SET-UP		
	DATE/TIME	100		FUNCTION (Fn) SETTING	105
	TIME DIFFERENCE	100		POWER MANAGEMENT	105
	言語/LANG.	101	 2	SAVE DATA SET-UP	106
 1	RESET	101		CONNECTION SETTING	108
	SOUND & FLASH	101		FORMAT	111
	SOUND SET-UP	102			
	SCREEN SET-UP	103			



Table of Contents









Introduction.....	ii
For the Latest Information.....	ii
Menu List.....	iv
Shooting Menus.....	iv
Playback Menus.....	v
Setup Menus.....	v
Supplied Accessories.....	xii
Product Features and Precautions for Use.....	xiii
About This Manual.....	xvii
Symbols and Conventions.....	xvii
Terminology.....	xvii

1 Before You Begin **1**





















Parts of the Camera.....	2
The Selector.....	4
The Burst Mode Button.....	5
Camera Displays.....	6
The LCD Monitor.....	6
Adjusting Display Brightness.....	8
The DISP/BACK Button.....	8
Customizing the Standard Display.....	9
Using the Menus.....	11

2 First Steps **13**

Attaching the Strap.....	14
Inserting the Battery and a Memory Card.....	15
Compatible Memory Cards.....	18
Charging the Battery.....	20
Turning the Camera On and Off.....	23
Checking the Battery Level.....	24
Basic Setup.....	25
Choosing a Different Language.....	27
Changing the Time and Date.....	27





















3 Basic Photography and Playback	29
Taking Photographs	30
Viewing Pictures	32
Deleting Pictures	33
4 Movie Recording and Playback	35
Recording Movies	36
Adjusting Movie Settings	37
Viewing Movies	38
5 Taking Photographs	41
Choosing a Shooting Mode	42
Shooting Mode Options	43
 ADVANCED SR AUTO	44
 MULTIPLE EXPOSURE	45
 ADVANCED FILTER	46
 PANORAMA	48
 FIREWORKS	51
 CALS	51
Exposure Compensation	52
Continuous Shooting (Burst Mode)	53
 CONTINUOUS (HIGH / MIDDLE / LOW)	54
 4K BURST	54
HDR	56
Focus Mode	57
Focus/Exposure Lock	58
Using the Flash	59
White Balance	60
Using the Self Timer	61
2 SEC/10 SEC	62
FACE AUTO SHUTTER	62
SMILE	63
BUDDY	63
GROUP	64

6 The Shooting Menus 65









SHOOTING MENU ( /  / )	66
 SHOOTING MODE	66
 AF/MF SETTING	66
FOCUS MODE	66
FACE/EYE DETECTION SETTING	66
AF ILLUMINATOR	67
 RELEASE TYPE	68
 ISO	68
 IMAGE SIZE	69
 IMAGE QUALITY	70
 FINEPIX COLOR	70
 SELF-TIMER	70
 INTERVAL TIMER SHOOTING	71
 TIME-LAPSE MOVIE MODE	72
 WHITE BALANCE	73
 FLASH SET-UP	73
FLASH MODE	73
FLASH COMPENSATION	73
RED EYE REMOVAL	73
 MOVIE SET-UP	74
MOVIE MODE	74
HD HIGH SPEED VIDEO	75
FOCUS MODE	75
WIND FILTER	75
 IS MODE	76
 DIGITAL IMAGE STABILIZER	76
 WIRELESS COMMUNICATION	77
 INTELLIGENT DIGITAL ZOOM	78





7 Playback and the Playback Menu 79

The Playback Display	80
The DISP/BACK Button	81
Viewing Pictures	82
Playback Zoom	83
Multi-Frame Playback	83

The Playback Menu ( /  / )	84
 IMAGE TRANSFER ORDER	84
 WIRELESS COMMUNICATION	85
 IMAGE SEARCH	86
 ERASE	87
 MOVIE EDIT	89
 CROP	91
 RESIZE	91
 PROTECT	92
 IMAGE ROTATE	92
 RED EYE REMOVAL	93
 SLIDE SHOW	93
 PHOTOBOOK ASSIST	94
 PC AUTO SAVE	95
 COPY	96
 PRINT ORDER (DPOF)	97
 instax PRINTER PRINT	98
 DISP ASPECT	98

8 The Setup Menus 99

The Setup Menu ( / )	100
 DATE/TIME	100
 TIME DIFFERENCE	100
 言語/LANG.	101
 RESET	101
 SOUND & FLASH	101
 SOUND SET-UP	102
OPERATION VOL.	102
SHUTTER VOLUME	102
SHUTTER SOUND	102
PLAYBACK VOLUME	102
 SCREEN SET-UP	103
IMAGE DISP.	103
LCD BRIGHTNESS	103
LCD COLOR	103
FRAMING GUIDELINE	104

AUTOROTATE PB.....	104
DISP. CUSTOM SETTING.....	104
 FUNCTION (Fn) SETTING.....	105
 POWER MANAGEMENT.....	105
AUTO POWER OFF.....	105
HIGH PERFORMANCE.....	105
 SAVE DATA SET-UP.....	106
FRAME NO.....	106
DATE STAMP.....	107
 CONNECTION SETTING.....	108
Bluetooth SETTINGS.....	108
PC AUTO SAVE.....	109
instax PRINTER CONNECTION SETTING.....	109
GENERAL SETTINGS.....	110
INFORMATION.....	110
RESET WIRELESS SETTING.....	110
 FORMAT.....	111

9 Shortcuts 113

The Fn (Function) Buttons.....	114
Assigning a Role to the Function Buttons.....	115

10 Optional Accessories 117

Accessories from Fujifilm.....	118
--------------------------------	-----

11 Connections 119

HDMI Output.....	120
Connecting to HDMI Devices.....	120
Wireless Connections (Bluetooth®, Wireless LAN/Wi-Fi).....	122
Smart Phones and Tablets: FUJIFILM Camera Remote.....	122
Copying Pictures to a Computer: PC AutoSave.....	124
Connecting to Computers via USB.....	125
Windows (MyFinePix Studio).....	125
Mac OS X/macOS.....	125
Connecting the Camera.....	126

instax SHARE Printers	128
Establishing a Connection	128
Printing Pictures.....	129
12 Technical Notes	131
Software from Fujifilm.....	132
FUJIFILM Camera Remote	132
FUJIFILM PC AutoSave	132
MyFinePix Studio.....	132
For Your Safety	133
Product Care	142
Firmware Updates.....	143
Checking the Firmware Version	143
Troubleshooting.....	144
Warning Messages and Displays	152
Memory Card Capacity	155
Specifications	156

Supplied Accessories

The following are included with the camera:

- NP-45S rechargeable battery
- AC-5VG AC power adapter
- Plug adapter (Shape of adapter varies with region of sale.)
- USB cable
- Strap
- *User Guide/Basic Manual*

Product Features and Precautions for Use

Water, Dust, and Shock Resistance

- ① The camera complies with JIS Class 8 water resistance and JIS Class 6 (IP68) dust resistance standards, and has passed Fujifilm drop tests (drop height: 1.80 m/5.9 ft.; impact surface: plywood, thickness 5 cm/2.0 in.) compliant with MIL-STD 810F Method 516.5: Shock. These results were obtained through in-house testing and are not a blanket guarantee of water resistance or invulnerability to damage or destruction. The accessories supplied with the camera are not water resistant.

Before Use

- 1 Inspect the water-resistant seal and adjacent surfaces and remove any dust, sand, or other foreign matter using a soft, dry cloth.

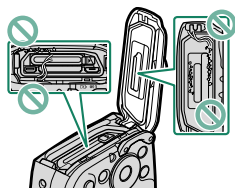

- ① Have the water-resistant seal replaced if it is deformed or otherwise damaged (note that a fee is charged for this service; contact your retailer or a Fujifilm-authorized repair technician for more information). Failure to replace the seal could result in leaks and damage to the camera.

- 2 Holding the battery-chamber cover closed against the camera body (①), rotate the latch until it clicks into place (②), indicating that the cover is secure.

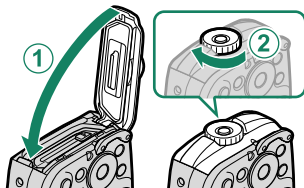

- 3 Check that the cover is secure by rotating the latch in the opposite direction and confirming that the cover does not open.

- ① The front surface of the camera lens is protected by a sheet of glass. Foreign matter on the glass will appear in photographs; keep the glass clean at all times.
- ① Be sure that the battery-chamber is fully latched. The presence of water, mud, or sand in the camera could cause malfunction.
- ① Do not open or close the battery-chamber cover with wet hands or in locations that are dusty, sandy, or near water, for example while on or by a body of water.
- ① Be sure the camera is completely dry before inserting or removing batteries or memory cards or connecting the USB or HDMI cable.
- ① The camera does not float. Be sure to attach the strap and keep it around your wrist when using the camera.

■ During Use

- ① Restrict underwater use to depths of 25 m (82 ft.) or less and periods shorter than 120 minutes. Clean and dry the camera within one hour of using it underwater.
- ① The interior of the camera is not waterproof. Do not open or close the battery-chamber cover while under water. After cleaning the camera, be sure it is completely dry before opening or closing the battery-chamber cover.
- ① Do not use in hot springs or heated pools.
- ① The camera may lose water resistance if subjected to excessive force or vibration. Do not dive into water with the camera or otherwise subject it to excessive force. In the event the camera is subjected to strong physical shocks, contact your retailer or a Fujifilm-authorized repair technician.
- ① If the camera is left on the sand, its temperature may exceed operating limits and sand may get into the speaker or microphone.
- ① Sunscreen, suntan lotion, or other oily substances may discolor the camera body and should be removed with a damp cloth.
- ① Note that the color of the supplied strap may fade or transfer to other items if it is exposed to moisture or friction.

■ After Use

Perform the following steps after using the camera underwater or in locations where foreign matter might adhere to the camera body.

- 1** Securely close the battery-chamber cover and rinse the camera under the tap or leave it in a basin of fresh water for about ten minutes.

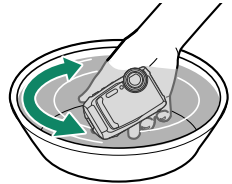

- 2** Remove water from the camera with a soft, dry cloth and leave it to dry in a well-ventilated location in the shade.
- 3** After confirming that the camera has dried and is free of water droplets, open the battery-chamber cover and use a soft, dry cloth to remove any water, dust, or other foreign matter from the battery chamber.

- ⓘ Remove any foreign matter from the water-resistant seal and adjacent surfaces. Foreign matter could damage the seal, lowering water resistance.
- ⓘ Liquid soaps, detergents, alcohol, and other cleansers may affect water resistance and should never be used.
- ⓘ After use, remove water droplets and foreign matter with a dry cloth, firmly latch the battery-chamber cover, and soak the camera in fresh water for about ten minutes. Dry the camera thoroughly after removing it from the water.

■ Storage and Maintenance

- ① Do not store at temperatures below 0 °C (32 °F) or above 40 °C (104 °F).
- ① To ensure continued water resistance, it is recommended that you have the water-resistant seal replaced about once a year (a fee is charged for this service). Contact your retailer or a Fujifilm-authorized repair technician for more information.

■ Condensation Inside the Lens

In some environments, condensation (fog) may form inside of lens. This does not indicate a malfunction. Condensation can be removed by leaving the battery-chamber cover open in a location with a steady temperature that is free of heat, humidity, sand, and dust.

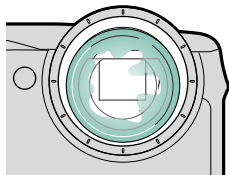

Condensation

Condensation is particularly likely to occur if the camera is placed in cold water after being exposed to high temperatures or taken from a cold to a warm environment or if the battery chamber is opened in a humid location.

■ Cold Climates

- ① Battery performance drops at low temperatures, reducing the number of pictures that can be taken. Insulate the camera to keep it warm or place it in your clothing.
- ① Use an NP-45S battery.
- ① Display response may slow at low temperatures. This is not a malfunction.

About This Manual

This manual contains instructions for your FUJIFILM FinePix XP140 digital camera. Be sure you have read and understood its contents before proceeding.

Symbols and Conventions

The following symbols are used in this manual:



Information that should be read to prevent damage to the product.



Additional information that may be helpful when using the product.



Pages on which related information may be found.

Menus and other text in the displays are shown in **bold**. Illustrations are for explanatory purposes only; drawings may be simplified, while photographs are not necessarily taken with the model of camera described in this manual.

Terminology

The optional SD, SDHC, and SDXC memory cards the camera uses to store pictures are referred to as “memory cards”. The LCD monitor may be referred to as the “LCD”.

MEMO

Before You Begin



Parts of the Camera

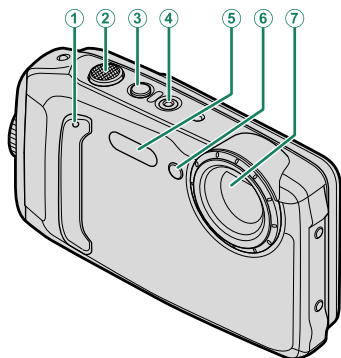

① Microphone.....	36	⑤ Flash.....	59, 73
② Shutter button.....	31	⑥ Self-timer lamp.....	61, 70
③ ON/OFF button.....	23	AF-assist illuminator.....	30, 67
④  (movie recording) button.....	36	⑦ Lens/protective glass.....	30

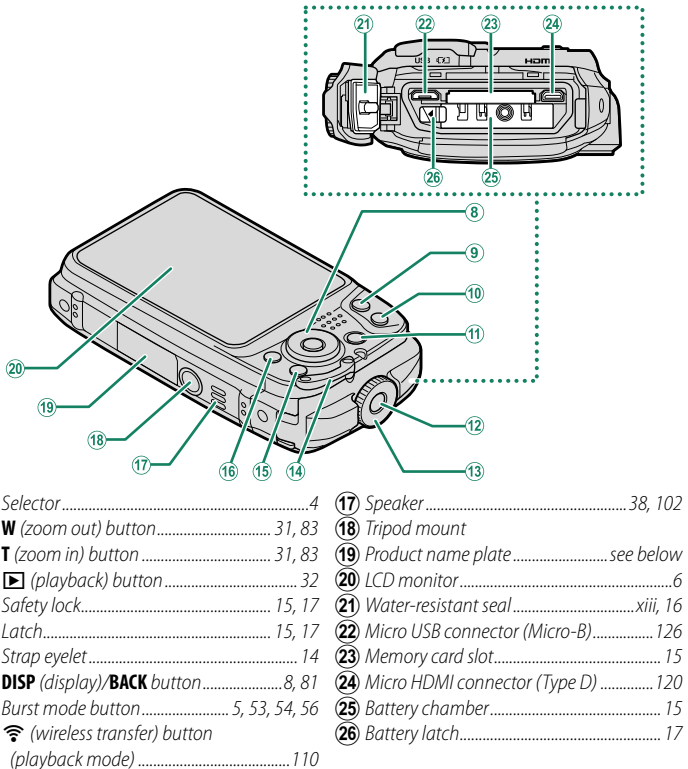

The Product name plate

Do not remove the product name plate, which provides the FCC ID, KC mark, CMIIT ID, serial number, and other important information.

The Selector

Use the ▲▼◀▶ (up, down, left, and right) buttons to highlight menu items or access camera functions.

- 1 Move cursor up (▲)
☒ (exposure compensation) button 52
🗑 (delete) button 33
- 2 Move cursor left (◀)
Fn (function) button 114
- 3 Move cursor right (▶)
⚡ (flash) button 59, 114
- 4 Move cursor down (▼)
⌚ (self-timer) button 61, 114
- 5 MENU/OK button 11, 66, 84, 100

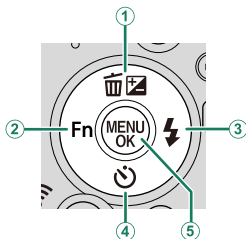

The Fn (Function) Buttons

- The ⚡ (flash) and ⌚ (self-timer) buttons can also serve as **Fn** (function) buttons. Pressing and holding the ▼, ◀, or ▶ button during shooting activates the assigned function, displaying a menu of options.
- The roles assigned to the function buttons can be selected using the **Fn FUNCTION (Fn) SETTING** item in the setup menu (📖 105, 115).
- Role selection can also be accessed by pressing and holding the function or **DISP/BACK** button.

The Burst Mode Button

Press the burst-mode button (📷) to switch between single-frame and burst modes.

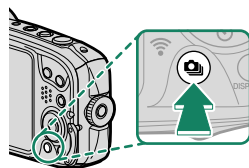

Mode		📖	Mode		📖
📷	STILL IMAGE	30	4K	4K BURST	54
📷	CONTINUOUS	54	HDR	HDR	56

Camera Displays

This section lists the indicators that may be displayed during shooting.

! For illustrative purposes, displays are shown with all indicators lit.

The LCD Monitor

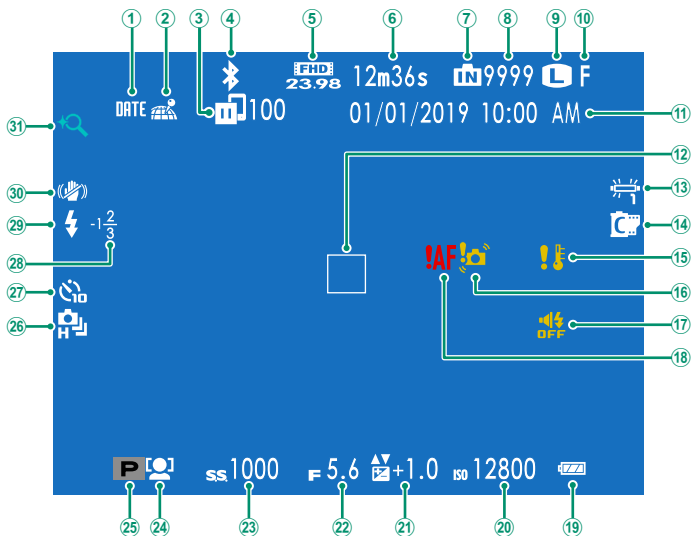

① Date stamp.....	107	①7 Sound and flash indicator	101
② Location data download status.....	110	①8 Focus warning.....	31
③ Image transfer status.....	84	①9 Battery level.....	24
④ Bluetooth ON/OFF.....	108	②0 Sensitivity.....	68
⑤ Movie mode	36, 74	②1 Exposure compensation.....	52
⑥ Movie recording time remaining	36	②2 Aperture	
⑦ Internal memory indicator ¹		②3 Shutter speed	
⑧ Number of available frames ²	155	②4 Face/eye detection setting.....	66
⑨ Image size.....	69	②5 Shooting mode.....	42
⑩ Image quality.....	70	②6 Continuous mode.....	53
⑪ Date and time.....	25, 100	②7 Self-timer indicator (Interval shooting / Time-lapse movie).....	70
⑫ Focus frame.....	58	②8 Flash compensation	73
⑬ White balance	60, 73	②9 Flash mode.....	59
⑭ FINEPIX color.....	70	③0 IS mode.....	76
⑮ Temperature warning	154	③1 Intelligent digital zoom.....	78
⑯ Blur warning	152		

- 1 **IN**: indicates that no memory card is inserted and that pictures will be stored in the camera's internal memory; flashes yellow while images are recorded. If a memory card is inserted, a yellow **■** icon will flash in the display while images are recorded.
- 2 Shows "9999" if there is space for over 9999 frames.

Adjusting Display Brightness

Use the items in the **SCREEN SET-UP** menu to adjust the brightness and hue of the LCD monitor when changes in ambient brightness make the display difficult to read. Choose **LCD BRIGHTNESS** to adjust brightness or **LCD COLOR** to adjust hue.

The DISP/BACK Button

Press **DISP/BACK** to cycle through display modes as follows.

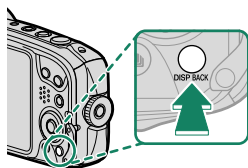

Standard



Information off



Customizing the Standard Display

To choose the items shown in the standard display:

- 1 Display standard indicators.**
Use the **DISP/BACK** button to display standard indicators.
- 2 Select DISP. CUSTOM SETTING.**
Select **SCREEN SET-UP > DISP. CUSTOM SETTING** in the setup menu.

- 3 Choose items.**
Highlight items and press **MENU/OK** to select or deselect.

Item	Default	Item	Default
FRAMING GUIDELINE	<input type="checkbox"/>	DUAL IS MODE	<input checked="" type="checkbox"/>
ELECTRONIC LEVEL	<input type="checkbox"/>	WHITE BALANCE	<input checked="" type="checkbox"/>
FOCUS FRAME	<input checked="" type="checkbox"/>	FINEPIX COLOR	<input checked="" type="checkbox"/>
SHOOTING MODE	<input checked="" type="checkbox"/>	FRAMES REMAINING	<input checked="" type="checkbox"/>
APERTURE/S-SPEED/ISO	<input checked="" type="checkbox"/>	IMAGE SIZE/QUALITY	<input checked="" type="checkbox"/>
INFORMATION BACKGROUND	<input type="checkbox"/>	MOVIE MODE & REC. TIME	<input checked="" type="checkbox"/>
Expo. Comp.(Digit)	<input checked="" type="checkbox"/>	INTELLIGENT DIGITAL ZOOM	<input checked="" type="checkbox"/>
FLASH	<input checked="" type="checkbox"/>	AUTO IMAGE TRANSFER	<input checked="" type="checkbox"/>
CONTINUOUS MODE	<input checked="" type="checkbox"/>	BATTERY LEVEL	<input checked="" type="checkbox"/>

- 4 Save changes.**
Press **DISP/BACK** to save changes.
- 5 Exit the menus.**
Press **DISP/BACK** as needed to exit the menus and return to the shooting display.

Virtual Horizon

Selecting **ELECTRONIC LEVEL** displays a virtual horizon. The camera is level when the two lines overlap. Note that the virtual horizon may not be displayed if the camera lens is pointed up or down.

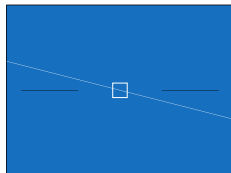

Using the Menu

To display the menu, press **MENU/OK**.

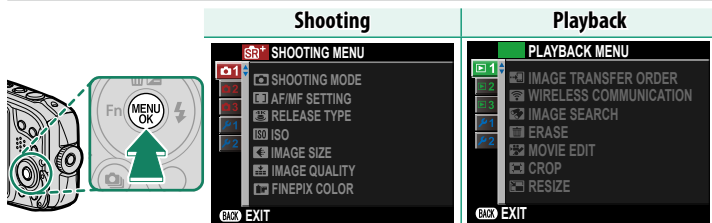

To navigate the menus:

- 1 Press **MENU/OK** to display the menus.

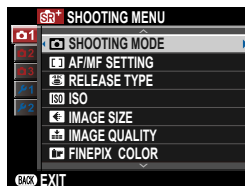

- 2 Press the selector left to highlight the tab for the current menu.



Tab

- 3 Press the selector up or down to highlight the tab (**1**, **2**, **3**, **1**, **2**, **3**, **1**, or **2**) containing the desired item.
- 4 Press the selector right to place the cursor in the menu.

First Steps

2

Attaching the Strap

Attach the strap to the eyelet as shown.

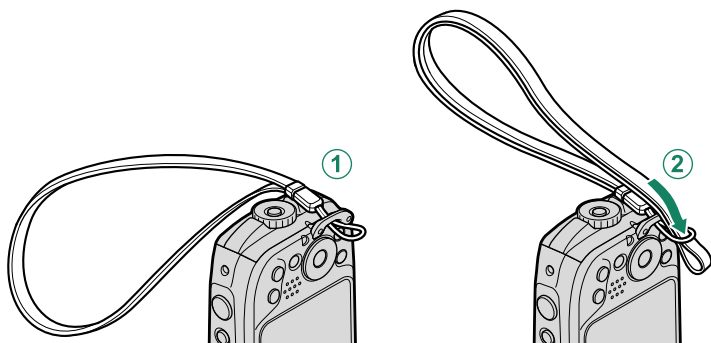

! To avoid dropping the camera, be sure the strap is correctly secured.

Inserting the Battery and a Memory Card

Insert the battery and memory card as described below.

! Before proceeding, confirm that the water-resistant seal is free of foreign matter as described on page xiii.

1 Open the battery-chamber cover.

Keeping the safety lock pressed (①), rotate the latch (②) and open the battery-chamber cover (③).

Remove water droplets and other foreign matter with a dry cloth before opening the battery-chamber cover.

- !** Do not open the battery-chamber cover when the camera is on. Failure to observe this precaution could result in damage to image files or memory cards.
- Do not use excessive force when handling the battery-chamber cover.

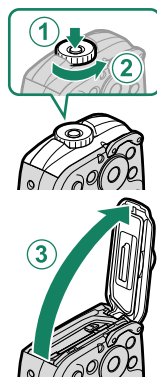

2 Insert the battery as shown.

Using the battery to keep the battery latch pressed to one side, insert the battery contacts first in the direction shown by the arrow.

- !** Inserting the battery in the incorrect orientation could damage the camera. Be sure to insert the battery in the correct orientation.
- Confirm that the battery is securely latched.

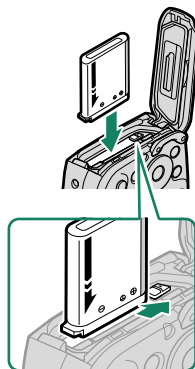

3 Insert the memory card.

- Be sure card is in the correct orientation; do not insert at an angle or use force. If the memory card is not correctly inserted or no memory card is inserted, **IN** will appear in the LCD monitor and internal memory will be used for recording and playback.
- Holding the card in the orientation shown, slide it in until it clicks into place at the back of the slot.

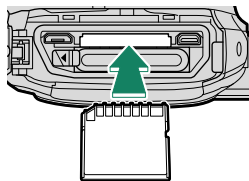

4 Holding the battery-chamber cover closed against the camera body (1), rotate the latch until it clicks into place (2), indicating that the cover is secure.

- If the cover does not close, check that the battery is in the correct orientation.
- Before closing the cover, confirm that there is no dust, sand, or other foreign matter on the water-resistant seal or adjacent surfaces.
- When closing the battery-chamber cover, do not subject it to excessive horizontal forces. Failure to observe this precaution could cause the water-resistant seal to become misaligned, allowing water into the camera.
- Check that the cover is secure by rotating the latch in the opposite direction and confirming that the cover does not open.

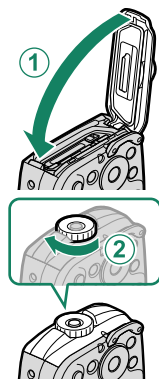

5 Format the memory card (📖 111).

- Format memory cards before first use, and be sure to reformat all memory cards after using them in a computer or other device.

Confirming That the Cover Is Latched

- Make sure that the strap is not caught in the cover.

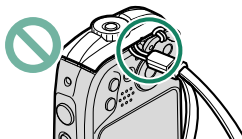

- Confirm that the latch is closed.

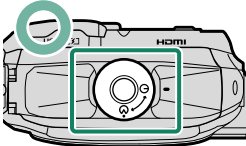
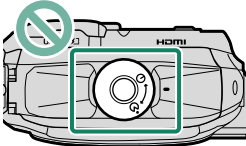
Correct	Incorrect
 <p data-bbox="140 572 508 631">The indicator shows that the latch is in the closed position.</p>	 <p data-bbox="550 572 917 631">The indicator shows that the latch is not in the closed position.</p>

Removing the Battery and Memory Card

Before removing the battery or memory card, *turn the camera off* and open the battery-chamber cover.

To remove the battery, press the battery latch to the side, and slide the battery out of the camera as shown.

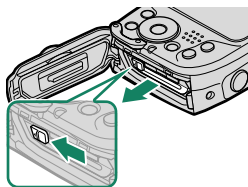

- ⚠ The battery may become hot when used in high-temperature environments. Observe caution when removing the battery.

To remove the memory card, press it in and release it slowly. The card can then be removed by hand. When a memory card is removed, the card could be ejected too quickly. Use your finger to hold it and gently release the card.

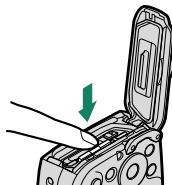

- ⚠ Press the center of the card when ejecting it.

Compatible Memory Cards

- The camera can be used with SD, SDHC, and SDXC memory cards. The UHS-I bus interface is supported.
- Use a memory card with a UHS speed class of 3 or better for 4K burst photography or when recording movies.
- A list of supported memory cards is available on the Fujifilm website. For details, visit:
http://www.fujifilm.com/support/digital_cameras/compatibility/.



- Do not turn the camera off or remove the memory card while the memory card is being formatted or data are being recorded to or deleted from the card. Failure to observe this precaution could damage the card.
- Memory cards can be locked, making it impossible to format the card or to record or delete images. Before inserting a memory card, slide the write-protect switch to the unlocked position.
- Memory cards are small and can be swallowed; keep out of reach of children. If a child swallows a memory card, seek medical assistance immediately.
- miniSD or microSD adapters that are larger or smaller than memory cards may not eject normally; if the card does not eject, take the camera to an authorized service representative. Do not forcibly remove the card.
- Do not affix labels or other objects to memory cards. Peeling labels can cause camera malfunction.
- Movie recording may be interrupted with some types of memory card.
- The data in internal memory may be erased or corrupted when the camera is repaired. Please note that the repairer will be able to view pictures in internal memory.
- With the first shot taken after a memory card or internal memory is formatted in the camera, the camera creates a folder in which pictures are stored. Do not rename or delete this folder or use a computer or other device to edit, delete, or rename image files. Always use the camera to delete pictures from memory cards and internal memory; before editing or renaming files, copy them to a computer and edit or rename the copies, not the originals. Renaming the files on the camera can cause problems during playback.

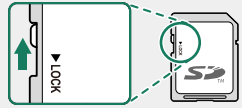

Charging the Battery

The battery is not charged at shipment. Turn the camera off and charge the battery before use. The camera charges the battery internally.

- An NP-45S rechargeable battery is supplied with the camera.
- Charging takes about 120 minutes.

1 Attach the plug adapter to the AC power adapter.

Attach the plug adapter as shown, making sure that it is fully inserted and clicks into place on the AC power adapter terminals.

- The supplied plug adapter is for use exclusively with the AC-5VG AC power adapter. Do not use it with other devices.
- The shape of the plug adapter varies with the country of sale.

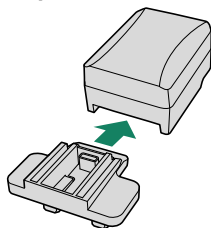

2 Open the battery-chamber cover.

Keeping the safety lock pressed (①), rotate the latch (②) and open the battery-chamber cover (③).

Before opening the battery-chamber cover, use a soft cloth to remove any water droplets or other foreign matter from the camera.

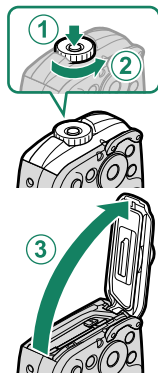

3 Charge the battery.

Connect the camera to the supplied AC power adapter using the supplied USB cable. Then plug the AC power adapter into an indoor power outlet.

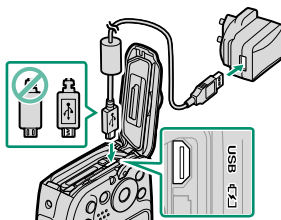

- Connect the cable to the camera's Micro USB (Micro-B) connector.
- Be sure the connectors are in the correct orientation and then insert them fully.

Charge Status

The self-timer lamp shows battery charge status as follows.

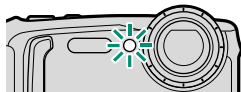

Self-timer lamp	Battery status
On	Battery charging.
Off	Charging complete.
Blinks	Battery fault.



- The battery will not charge while the camera is on.
- The supplied AC power adapter is compatible with power supplies of 100 to 240 V (a plug adapter may be needed for overseas use).
- The battery is not charged at shipment. Turn the camera off and charge the battery before use.
- Do not affix labels or other objects to the battery. Failure to observe this precaution could make it impossible to remove the battery from the camera.
- Do not short the battery terminals. The battery could overheat.
- Read the cautions in “The Battery and Power Supply”.
- Use only genuine Fujifilm rechargeable batteries designated for use in this camera. Failure to observe this precaution could result in product malfunction.
- Do not remove the labels from the battery or attempt to split or peel the outer casing.
- The battery gradually loses its charge when not in use. Charge the battery one or two days before use. If the battery fails to hold a charge, it has reached the end of its charging life and must be replaced.
- Unplug the AC power adapter from the power outlet when it is not in use.
- Remove dirt from the battery terminals with a clean, dry cloth. Failure to observe this precaution could prevent the battery from charging.
- Charging times may increase at very low or very high temperatures.
- The camera operates in external power mode if the camera is turned on while plugged into AC power with the battery inserted.



Turning the Camera On and Off

Use the **ON/OFF** button to turn the camera on and off.

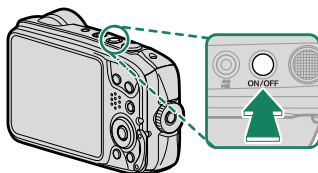

Press the **ON/OFF** button once to turn the camera on and again to turn it off.



- Fingerprints and other marks on the protective glass covering the lens can affect pictures. Keep the glass clean.
- You may be prompted to confirm that the battery-chamber cover is locked, but this does not indicate a malfunction.

- Pressing the  button during shooting starts playback.
- Press the shutter button halfway to return to shooting mode.
- The camera will turn off automatically if no operations are performed for the length of time selected for  **POWER MANAGEMENT** > **AUTO POWER OFF**.
- Selecting **HIGH PERFORMANCE** for  **POWER MANAGEMENT** reduces startup time.

Playback Mode

- To turn the camera on and begin playback, press the  button for about a second.
- Press the  button again or press the **ON/OFF** button to turn the camera off.

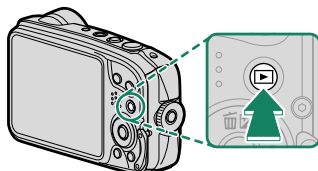





Checking the Battery Level

After turning the camera on, check the battery level in the display.

Battery level is shown as follows:



Indicator	Description
 (white)	Battery partially discharged.
 (white)	Battery more than half discharged.
 (red)	Low battery. Charge battery.
 (blinks red)	Battery exhausted. Turn camera off and recharge battery.

Basic Setup

When you turn the camera on for the first time, you can choose a language and set the camera clock. At default settings, you can also pair the camera with a smartphone or tablet so that you can later synchronize the clocks or download pictures. Follow the steps below when turning the camera on for the first time.

 If you intend to pair the camera with a smartphone or tablet, install and launch the latest version of the FUJIFILM Camera Remote App on the smart device before proceeding. For more information, visit: http://app.fujifilm-dsc.com/en/camera_remote/

1 Turn the camera on.

A language-selection dialog will be displayed.

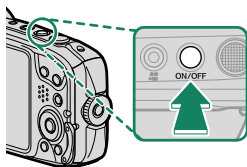

2 Choose a language.

Highlight a language and press **MENU/OK**.

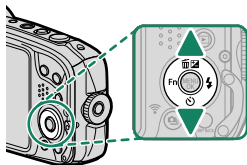

3 Pair the camera with the smartphone or tablet.

Press **MENU/OK** on the camera and tap **PAIRING REGISTRATION** in FUJIFILM Camera Remote.

 To skip pairing, press **DISP/BACK**.





4 Check the time.

When pairing is complete, you will be prompted to set the camera clock to the time reported by the smartphone or tablet. Check that the time is correct.

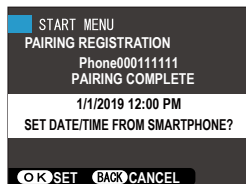
 To set the clock manually, press **DISP/BACK** (📖 27).



5 Synchronize the camera settings with the settings configured on your smartphone or tablet.

 The option selected can be changed at any time using  **CONNECTION SETTING > Bluetooth SETTINGS**.

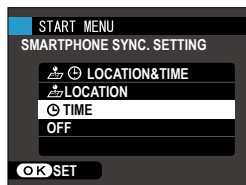

6 Set the clock.

Press **MENU/OK** to set the camera clock to the time reported by the smartphone or tablet and exit to shooting mode.

 If the battery is removed for an extended period, the camera clock will be reset and the language-selection dialog will be displayed when the camera is turned on.

Skipping the Current Step

Press **DISP/BACK** to skip the current step. A confirmation dialog will be displayed; select **NO** to avoid repeating any steps you skipped the next time the camera is turned on.

Choosing a Different Language

To change the language:

- 1 Display language options.**
Display the setup menu and select  言語/LANG..
- 2 Choose a language.**
Highlight the desired option and press **MENU/OK**.

Changing the Time and Date

To set the camera clock:

- 1 Display DATE/TIME options.**
Display the setup menu and select  DATE/TIME.
- 2 Set the clock.**
Press the selector left or right to highlight the year, month, day, hour, or minute and press up or down to change. Press **MENU/OK** to set the clock.

Basic Photography and Playback

3

Taking Photographs

This section explains basic photography.

1 Turn the camera on.

Press the **ON/OFF** button to turn the camera on. **SR+** shooting indicators will be displayed.

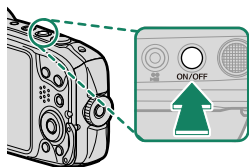

- 1 **Scene:** The camera automatically selects the appropriate scene.
- 2 **The  Icon:** Shows that the camera is focusing on the subjects' eyes.

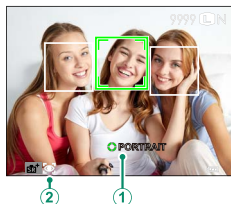

 In **SR+** mode, the camera continuously adjusts focus and searches for eyes, increasing the drain on the battery; in addition, the sound of the camera focusing may be audible.

2 Ready the camera.

Hold the camera steady with both hands and brace your elbows against your sides. Shaking or unsteady hands can blur your shots.

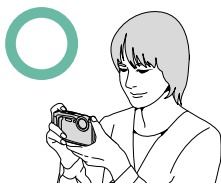

To prevent pictures that are out of focus or too dark (underexposed), keep your fingers and other objects away from the flash and from the protective glass covering the lens.

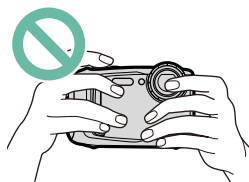

3 Frame the picture.

Use the zoom buttons to frame the picture in the display.

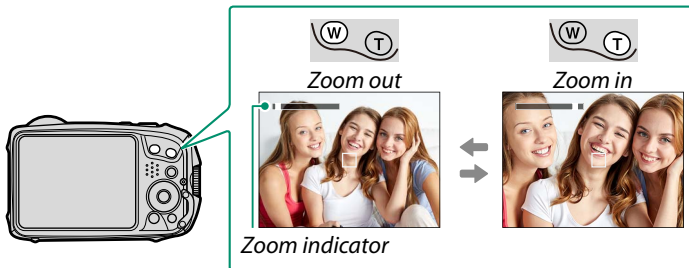

4 Focus.

Press the shutter button halfway to focus.

- **If the camera is able to focus**, it will beep twice and the focus frame will turn from white to green.
- **If the camera is unable to focus**, the focus frame will turn red and **!AF** will be displayed. Change the composition or use focus lock (📖 58).



- The lens may make a noise when the camera focuses; this is normal.
- If the subject is poorly lit, the AF-assist illuminator may light to assist the focus operation.
- Focus and exposure will lock when the shutter button is pressed halfway. Focus and exposure remain locked while the button is kept in this position (AF/AE lock).
- The camera will focus on subjects at any distance in the macro and standard focus ranges for the lens.

5 Shoot.

Smoothly press the shutter button the rest of the way down to take the picture.

Viewing Pictures

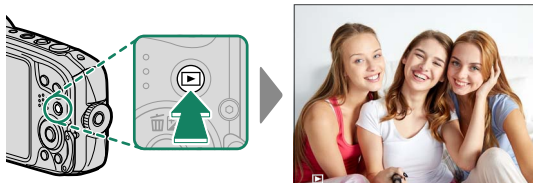

Pictures can be viewed in the LCD monitor.

To view pictures full frame, press .

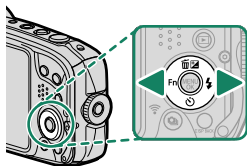

Press the selector right to view pictures in the order recorded, left to view pictures in reverse order. Keep the selector pressed to scroll rapidly to the desired frame.



 Pictures taken using other cameras are marked with a  ("gift image") icon to warn that they may not display correctly and that playback zoom may not be available.



Deleting Pictures

Use the (▲) button to delete pictures.



Deleted pictures cannot be recovered. Copy important pictures to a computer or other storage device before proceeding.

- 1 With a picture displayed full frame, press the (▲) button and select **FRAME**.

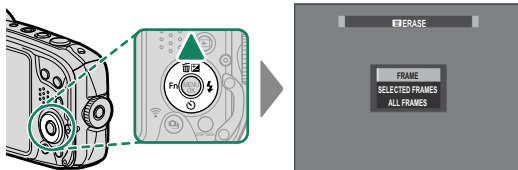

- 2 Press the selector left or right to scroll through pictures and press **MENU/OK** to delete.



- Pictures are deleted the moment you press the **MENU/OK** button; be careful not to delete pictures accidentally.
- Repeat as necessary to delete additional pictures. Display the picture to be deleted and press **MENU/OK**.
- Protected pictures cannot be deleted. Remove protection from any pictures you wish to delete (92).
- Pictures can also be deleted by **ERASE** from playback menu (87).

Movie Recording and Playback

4



Recording Movies

This section describes how to film movies.

- 1 Press to shoot a movie.

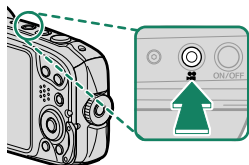

- A recording indicator () is displayed while recording is in progress.
- The display also shows the time remaining.





Zoom can be adjusted while recording is in progress (31).

- 2 To end recording, press the button again. Recording ends automatically when the movie reaches maximum length or memory is full.





- ! Electronic vibration reduction is not performed when **4K 2160/15P** or **FULL HD 1080/59.94P** is selected for **MOVIE SET-UP > MOVIE MODE** (74).
- Do not open the battery-chamber cover while recording movies. Failure to observe this precaution could prevent the movie from being played back.
- Use a memory card with a UHS speed class of 3 or better when recording movies.
- The area recorded when **ON** is selected for **DIGITAL IMAGE STABILIZER** is smaller than that shown in the monitor.
- Sound is recorded via the built-in microphone; do not cover the microphone during recording.
- Note that the microphone may pick up lens noise and other sounds made by the camera during recording.
- Vertical or horizontal streaks may appear in movies containing very bright subjects. This is normal and does not indicate a malfunction.

 Recording may be unavailable at some settings, while in other cases settings may not apply during recording.



DIGITAL IMAGE STABILIZER

Image stabilization can be used to correct for camera shake during filming, producing footage with less vibration. Image stabilization can be turned on or off using the  **DIGITAL IMAGE STABILIZER** option in the shooting menu ( 76).

Adjusting Movie Settings

- Adjust movie settings in the  **MOVIE SET-UP** menu.
- The movie type, frame size, and frame rate can be selected using  **MOVIE SET-UP > MOVIE MODE**.
- The AF-area mode for movie recording is selected using  **MOVIE SET-UP > FOCUS MODE**; choose from **CONTINUOUS AF** and **SINGLE AF**.
- Focus mode is selected using  **MOVIE SET-UP > FOCUS MODE**; for continuous focus adjustment, select **CONTINUOUS AF** or choose **SINGLE AF** and enable Intelligent Face Detection.

 The temperature of the camera may rise if it is used to record movies for an extended period or if the ambient temperature is high. This is normal and does not indicate a malfunction.

-  Exposure and white balance are adjusted automatically throughout recording. The color and brightness of the image may vary from that displayed before recording begins.
- If the subject is poorly lit, the AF-assist illuminator may light to assist the focus operation. To turn the AF-assist illuminator off, select **OFF** for  **AF/MF SETTING > AF ILLUMINATOR** ( 67).

Viewing Movies

View movies on the camera.

In full-frame playback, movies are identified by a  icon. Press the selector down to start movie playback.

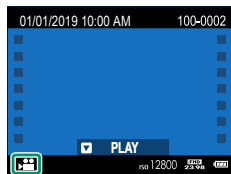

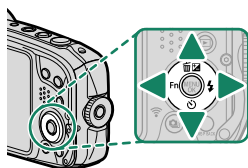

The following operations can be performed while a movie is displayed:



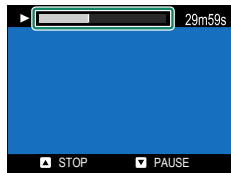

Selector	Full-frame playback	Playback in progress (▶)	Playback paused (⏸)
▲	Erase	End playback	
▼	Start playback	Pause playback	Start/ resume playback
◀▶	View other pictures	Adjust speed	Single frame rewind/ advance

Progress is shown in the display during playback.



-  Do not cover the speaker during playback.
- Sound is not played back if **OFF** is selected for  **SOUND & FLASH**.

 Press **MENU/OK** to pause playback and display volume controls. Press the selector up or down to adjust the volume; press **MENU/OK** again to resume playback. Volume can also be adjusted using  **SOUND SET-UP > PLAYBACK VOLUME** (📖 102).

Playback Speed

Press the selector left or right to adjust playback speed during playback. Speed is shown by the number of arrows (▶ or ◀).

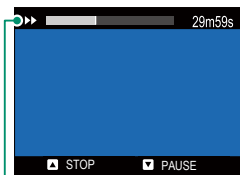

Arrows

Taking Photographs

5

Choosing a Shooting Mode

Choose a shooting mode according to the scene or type of subject.

- 1 Press **MENU/OK** to display the shooting menu.

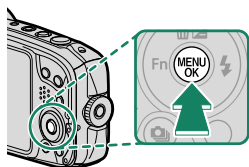

- 2 Highlight **SHOOTING MODE** and press the selector right to display shooting mode options.

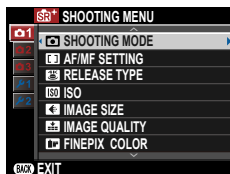



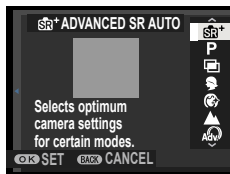















- 3 Highlight the desired mode and press **MENU/OK**.



- 4 Press **DISP/BACK** to exit to shooting mode.

Shooting Mode Options

Mode	Description
 ADVANCED SR AUTO	The camera automatically analyzes the composition and selects a scene according to shooting conditions and the type of subject (📖 44).
P PROGRAM AE	The camera sets exposure automatically.
 MULTIPLE EXPOSURE	Create a photograph that combines two exposures (📖 45).
 PORTRAIT	Choose for portraits.
 PORTRAIT ENHANCER	Processes portraits to give the subject a smooth, natural-looking complexion.
 LANDSCAPE	Choose for daylight shots of buildings and landscapes.
 ADVANCED FILTER	Take photos with filter effects (📖 46).
 PANORAMA	Pan the camera to record a series of shots that are joined together to form a panorama (📖 48).
 SPORT	Choose when photographing moving subjects.
 NIGHT	Choose this mode for poorly lit twilight or night scenes.
 NIGHT (TRIPOD)	Choose this mode for slow shutter speeds when shooting at night.
 FIREWORKS	Slow shutter speeds are used to capture the expanding burst of light from a firework (📖 51).
 SUNSET	Choose this mode to record the vivid colors in sunrises and sunsets.
 SNOW	Choose for crisp, clear shots that capture the brightness of scenes dominated by shining white snow.
 BEACH	Choose for crisp, clear shots that capture the brightness of sunlit beaches.
 UNDERWATER	Choose for underwater photography.
 PARTY	Capture indoor background lighting under low-light conditions.
 FLOWER	Choose for vivid close-ups of flowers.
 TEXT	Take clear pictures of text or drawings in print.
CRS CALS	Take pictures at size and image quality settings suitable for submission under Japanese Ministry of Land, Infrastructure, Transport and Tourism guidelines (📖 51).

SR+ ADVANCED SR AUTO

Select **SR+ ADVANCED SR AUTO** for shooting mode.

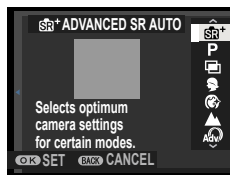

The camera automatically selects the appropriate scene.

Scene	Scene
AUTO	MACRO
PORTRAIT	NIGHT PORTRAIT
LANDSCAPE	BACKLIT PORTRAIT
NIGHT	SUNSET

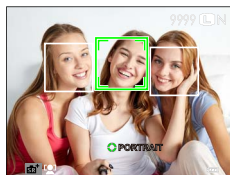

! The mode selected may vary with shooting conditions. The mode selected for a given subject may also change with shooting conditions. If the mode and subject do not match, select mode **P** (program AE).

- !** If the camera detects one or more portrait subjects, the face selected by the camera will be indicated by a green border; press the shutter button halfway to focus. If there is more than one face in the frame, the camera will select the face closest to the center. Other faces are indicated by white borders. To select a different face, press the selector left.
- If the camera detects a non-portrait subject, it will be indicated by a green border; press the shutter button halfway to focus. Press the selector left (◀) to switch focus from the selected subject to the subject at the center of the frame or back again.
- The function assigned to the ◀ button is disabled in **SR+ ADVANCED SR AUTO** mode.
- If the camera is moved or the subject changes position immediately before the shutter is released, the subject may not be in the green border when the picture is taken.
- Faces can be detected with the camera in vertical or horizontal orientation.
- The camera may be unable to detect the faces of subjects wearing glasses or whose eyes are hidden by hair or other objects.

MULTIPLE EXPOSURE

Create a photograph that combines two exposures.

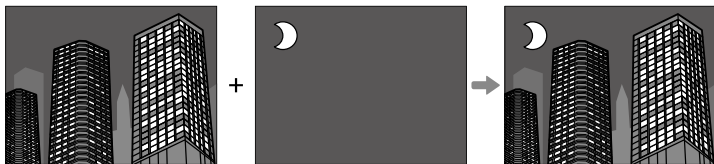

1 Select  **MULTIPLE EXPOSURE** for the shooting mode.

2 Take the first shot.

3 Press **MENU/OK**. The first shot will be shown superimposed on the view through the lens and you will be prompted to take the second shot.



- To return to Step 2 and retake the first shot, press the selector left.
- To save the first shot and exit without creating a multiple exposure, press **DISP/BACK**.

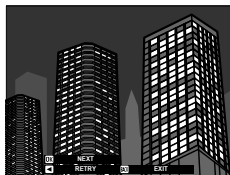

4 Take the second shot, using the first frame as a guide.



5 Press **MENU/OK** to create the multiple exposure, or press the selector left to return to Step 4 and retake the second shot.



ADVANCED FILTER

Take photos with filter effects.

- 1 Select **ADVANCED FILTER** for shooting mode.

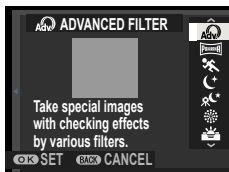





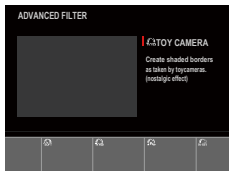











- Advanced filter options can also be displayed by pressing a function button. Advanced filter selection is assigned to the ◀ button by default.
- Advanced filter selection can also be assigned to other function buttons (📖 115).
- The ◀ button can also be assigned other functions using the **Fn FUNCTION (Fn) SETTING** item in the setup menu.

- 2 A menu of advanced filter options will be displayed.



3 Highlight one of the following options and press **MENU/OK**.

Filter	Description
 TOY CAMERA	Choose for a retro toy camera effect.
 POP COLOR	Create high-contrast images with saturated colors.
 HIGH-KEY	Create bright, low-contrast images.
 LOW-KEY	Create uniformly dark tones with few areas of emphasized highlights.
 FISH-EYE	Create a distorting effect of a fisheye lens.
 DYNAMIC TONE	Dynamic tone expression is used for a fantasy effect.
 MINIATURE*	The tops and bottoms of pictures are blurred for a diorama effect.
 CROSS SCREEN*	Create a star pattern where lines radiate out from bright objects. The effects of the cross screen filter can be viewed after shooting.
 RICH & FINE	Add a rich & fine effect recommend for table-top photography.
 MONOCHROME(NIR)	Monochrome photography as taken by Near-infrared camera.
 PARTIAL COLOR (RED)	Areas of the image that are the selected color are recorded in that color. All other areas of the image are recorded in black-and-white.
 PARTIAL COLOR (ORANGE)	
 PARTIAL COLOR (YELLOW)	
 PARTIAL COLOR (GREEN)	
 PARTIAL COLOR (BLUE)	
 PARTIAL COLOR (PURPLE)	
 SOFT FOCUS	Create a look that is evenly soft throughout the whole image.

* Not available when shooting movies.

 Depending on the subject and camera settings, images may in some cases be grainy or vary in brightness or hue.

PANORAMA

Follow an on-screen guide to create a panorama.

- 1 Select  PANORAMA for shooting mode.

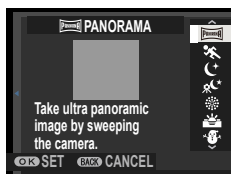

- 2 To select the size of the angle through which you will pan the camera while shooting, press the selector left. Highlight a size and press **MENU/OK**.
- 3 Press the selector right to view a choice of pan directions. Highlight a pan direction and press **MENU/OK**.

- 4 Press the shutter button all the way down to start recording. There is no need to keep the shutter button pressed during recording.

- 5 Pan the camera in the direction shown by the arrow. Shooting ends automatically when the camera is panned to the end of the guides and the panorama is complete.

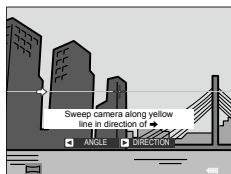

For Best Results

Prop your elbows against your sides and move the camera slowly in a small circle at a steady speed, keeping the camera parallel or at right angles to the horizon and being careful only to pan in the direction shown by the guides. Use a tripod for best results. If the desired results are not achieved, try panning at a different speed.

- ❗ • If the shutter button is pressed all the way down before the panorama is complete, shooting will end and no panorama may be recorded.
- The last part of the panorama may not be recorded if shooting ends before the panorama is complete.
- Panoramas are created from multiple frames, and the camera may in some cases be unable to stitch the frames together perfectly.
- Panoramas may be blurred if the subject is poorly lit.
- Shooting may be interrupted if the camera is panned too quickly or too slowly. Panning the camera in a direction other than that shown cancels shooting.
- The camera may in some cases record a greater or lesser angle than selected.
- The desired results may not be achieved with:
 - Moving subjects
 - Subjects close to the camera
 - Unvarying subjects such as the sky or a field of grass
 - Subjects that are in constant motion, such as waves and waterfalls
 - Subjects that undergo marked changes in brightness
- Exposure locks when the shutter button is pressed halfway for the first time.

Viewing Panoramas

With the panorama displayed full frame, press the selector down to start panorama playback. Vertical panoramas will scroll vertically, horizontal panoramas horizontally.

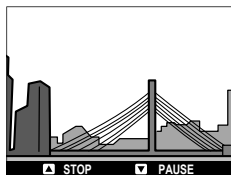
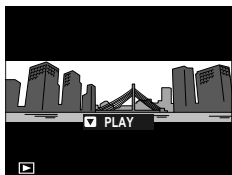

- To zoom the panorama in or out, pause playback and use the **W** (zoom out) and **T** (zoom in) buttons.
- Panorama playback is controlled using the multi selector.

Selector	Full-frame playback	Panorama playback	Panorama playback paused
▲ (Press up)	Erase	End playback	
▼ (Press down)	Start playback	Pause playback	Resume playback
◀▶ (Press left or right)	View other pictures	Choose pan direction	Scroll panorama manually

FIREWORKS

Slow shutter speeds are used to capture the expanding burst of light from a firework.

- 1 Select  **FIREWORKS** for shooting mode.





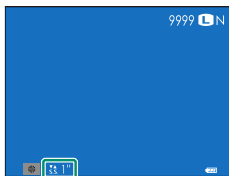



- 2 Choose a shutter speed. Press the selector up and then press it up or down to choose a shutter speed.
- 3 Press **MENU/OK** to select.



CALS CALS

Take pictures at size and image quality settings suitable for submission under Japanese Ministry of Land, Infrastructure, Transport and Tourism guidelines.

- 1 Select  **CALS CALS** for shooting mode.
- 2 Press **MENU/OK**.

 The  **IMAGE SIZE** and  **IMAGE QUALITY** items in the shooting menu are disabled in **CALS CALS** mode. To adjust image size and quality using the  **IMAGE SIZE** and  **IMAGE QUALITY** items, select a different mode.

Exposure Compensation

Adjust exposure.

- 1 Press the selector up () to display exposure compensation options.

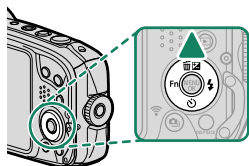

- 2 Press the selector up or down to choose an exposure compensation value and then press **MENU/OK**.

 Exposure compensation is unavailable in some modes.



Continuous Shooting (Burst Mode)

Capture motion in a series of pictures.

- 1 Press the burst-mode button (📷).
Burst mode options will be displayed.

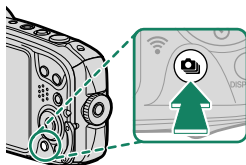



- 2 Press the selector up or down to highlight **CONTINUOUS** (📷 54) or **4K BURST** (📷 54).
- 3 When **CONTINUOUS** is selected, you can press the selector left or right to choose the frame rate (**HIGH**, **MIDDLE**, or **LOW**).
- 4 Press **MENU/OK** to select.
- 5 Take pictures.

Viewing Pictures Taken Using Continuous Shooting

Only the first frame of each series will be displayed. Press the selector down to view the other pictures in the series.

- 📷 Pictures taken in continuous shooting mode have file names that start with "S".
e.g. S0010001.JPG

CONTINUOUS (HIGH / MIDDLE / LOW)

The camera takes pictures at the selected frame rate ( **HIGH**,  **MIDDLE**, or  **LOW**) while the shutter button is pressed. Shooting ends when the shutter button is released or the memory card is full.

-  If file numbering reaches 999 before shooting is complete, the remaining pictures will be recorded to a new folder.
- Shooting ends when the memory card or internal memory is full; the camera will record all photos shot to that point. Burst shooting may not begin if the space available on the memory card or in internal memory is insufficient.
- Frame rates may slow as more shots are taken.
- Frame rate varies with the scene, shutter speed, sensitivity, and focus mode.
- Depending on shooting conditions, frame rates may slow.
- The flash cannot be used.
- Recording times may increase during burst shooting.

4K BURST

Shoot a burst of 4K pictures and choose which shots to save.

Select  **4K BURST** in the burst mode menu.

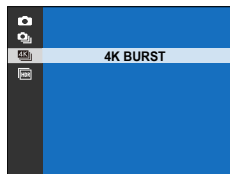



-  Use a memory card with a UHS speed class of 3 or better.
- Selecting 4K burst mode reduces the picture angle.

- 1 Shoot a burst of pictures with  **4K BURST** selected for burst mode.

 The function performed by the shutter button can be selected using the  **RELEASE TYPE** option in the shooting menu.

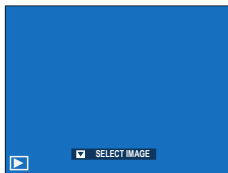
- 2 In full-frame playback, display a picture taken with  **4K BURST**. Press the selector down to view the pictures in the burst as a thumbnail list.



- 3 Press the selector left or right to highlight frames and press the burst mode button () to save the highlighted frame as a separate image.

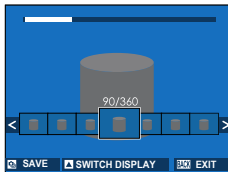

- 4 After saving the desired frames, press **DISP/BACK** to exit the thumbnail list.

 If the subject moves during shooting, the image may be distorted, while banding may occur in images taken under flickering or transient light sources such as fluorescent lights.

-  If **CONTINUOUS** is selected for  **SCREEN SET-UP > IMAGE DISP.**, the most recent picture will be displayed when shooting ends, allowing you to select the frames to be saved without exiting to playback mode.
- The flash cannot be used.

HDR

Each time the shutter button is pressed, the camera takes multiple shots at different exposures and combines them into a single high-dynamic-range image, reducing loss of detail in highlights and shadows.

- 1 Press the burst-mode button ()
Burst mode options will be displayed.

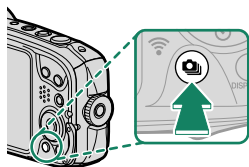

- 2 Press the selector up or down to highlight  HDR in the burst-mode menu.
- 3 Press the selector left or right to choose the amount exposure is varied over the course of each shot (**AUTO**, **1.0EV**, **1.5EV**, **2.0EV**, **2.5EV**, or **3.0EV**).
- 4 Press **MENU/OK** to select. The exposure range will be set to the selected value.
- 5 Take pictures.





-  • The camera may fail to record an image if the subject moves during shooting.
- If the camera is moved or the subject changes during shooting, the shots may be recorded separately instead of being combined into a single image.
- Keep the camera steady.

-  The camera displays the combined image after shooting. Press **MENU/OK** to save the image or **DISP/BACK** to end HDR shooting without recording the image.

Focus Mode

Use the **FOCUS MODE** option in the **AF/MF SETTING** menu to choose how the camera focuses.

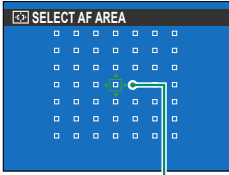
- 1 Press **MENU/OK** to display the menus.
- 2 Select **AF/MF SETTING > FOCUS MODE** in the shooting menu.
- 3 Choose from the following options:

Mode	Description
 MULTI	When the shutter button is pressed halfway, the camera detects high-contrast subjects and selects the focus area automatically.
 AREA	The focus area can be changed. Press the selector up, down, left, or right to move the focus area, and then press MENU/OK to apply the focus area setting.  <i>Focus area point</i>
 TRACKING	Position the subject in the center focus area and press DISP/BACK . Focus will track the subject as it moves through the frame.

Focus/Exposure Lock

Compose photographs with off-center subjects.

- 1 Focus:** Position the subject in the focus frame and press the shutter button halfway to lock focus and exposure. Focus and exposure will remain locked while the shutter button is pressed halfway (AF/AE lock).

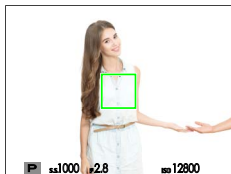

- 2 Recompose:** Keep the shutter button pressed halfway. Ensure that the distance to the subject does not change.

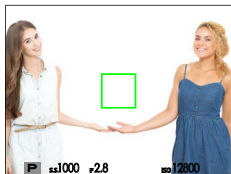

- 3 Shoot:** Press the button all the way down.

Autofocus

Although the camera boasts a high-precision autofocus system, it may be unable to focus on the subjects listed below.

- Very shiny subjects such as mirrors or car bodies.
- Subjects photographed through a window or other reflective object.
- Dark subjects and subjects that absorb rather than reflect light, such as hair or fur.
- Insubstantial subjects, such as smoke or flame.
- Subjects that show little contrast with the background.
- Subjects positioned in front of or behind a high-contrast object that is also in the focus frame (for example, a subject photographed against a backdrop of highly contrasting elements).

Using the Flash

Use the built-in flash for additional lighting when shooting at night or indoors under low light.

- 1 Press the **▶** (⚡ flash) button. Flash options will be displayed.

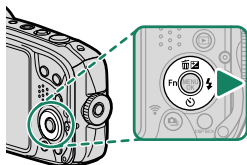

- The right (⚡ flash) button on the selector can be assigned other functions using the **Fn FUNCTION (Fn) SETTING** item in the setup menu. Its default role can also be assigned to other function buttons (📖 115).
- Settings can also be adjusted using the **⚡ FLASH SET-UP** item in the shooting menu.

- 2 Highlight one of the following options and press **MENU/OK**.

Mode	Description
AUTO (Auto flash) 👁️ RED EYE REDUCTION*	The flash fires when required.
⚡ FORCED FLASH 👁️⚡ FORCED FLASH*	The flash fires whenever a picture is taken.
S ⚡ SLOW SYNCHRO 👁️ RED EYE & SLOW*	Capture both the main subject and the background under low light (note that brightly lit scenes may be overexposed).
🚫 SUPPRESSED FLASH	The flash does not fire even when the subject is poorly lit. A tripod is recommended.







* Red-eye removal is available in these modes when Intelligent Face Detection is active and red-eye removal is on. Red-eye removal minimizes “red-eye” caused when light from the flash is reflected from the subject’s retinas.



- If **⚡** is displayed when the shutter button is pressed halfway, the flash will fire when the photo is taken.
- The flash fires several times with each shot. Do not move the camera until shooting is complete.

WB White Balance

For natural colors, choose a white balance option that matches the light source.

- 1 Press **MENU/OK** to display the shooting menu.
- 2 Highlight **WB WHITE BALANCE** in the shooting menu and press **MENU/OK** to view white balance options.
- 3 The following white balance options are available.

Option	Description
AUTO	White balance is adjusted automatically. Recommended in most situations.
	For subjects in direct sunlight.
	For subjects in the shade.
	Use under "daylight" fluorescent lights.
	Use under "warm white" fluorescent lights.
	Use under "cool white" fluorescent lights.
	Use under incandescent lighting.
	Reduces the blue cast typically associated with underwater lighting.

-  In conditions in which **AUTO** fails to produce the desired results—for example, under certain types of lighting or in close-ups of portrait subjects—choose a white balance option suited to the light source.
- White balance is adjusted for flash lighting only in **AUTO** and  modes. Turn the flash off using other white balance options.



Using the Self Timer

Use the timer for group- or self-portraits, to prevent blur caused by camera shake, or to release the shutter automatically when selected conditions are met.

- 1 Press the (self-timer) button. Self-timer options will be displayed.

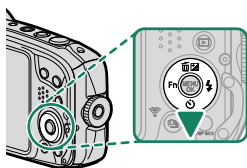

- The down (self-timer) button on the selector can be assigned other functions using the **Fn FUNCTION (Fn) SETTING** item in the setup menu. Its default role can also be assigned to other function buttons (115).
- Settings can also be adjusted using the **SELF-TIMER** item in the shooting menu.

- 2 Highlight one of the following options and press **MENU/OK**.

Option		Option	
2 SEC	62	BUDDY	63
10 SEC	62	GROUP	64
FACE AUTO SHUTTER	62	OFF	—
SMILE	63		



- Stand behind the camera when using the shutter button. Standing in front of the lens can interfere with focus and exposure.
- The self-timer turns off automatically when the camera is turned off.

- To stop the timer before the picture is taken, press **DISP/BACK**.
- Selecting **FACE AUTO SHUTTER**, **SMILE**, **BUDDY**, or **GROUP** sets **AF/MF SETTING > FACE/EYE DETECTION SETTING** to **FACE ON/EYE OFF**. The original setting is restored when the self timer is turned off.

2 SEC/10 SEC

The shutter is released 2 or 10 seconds after the shutter button is pressed.

- 1 Highlight either of the following options in the self-timer menu and press **MENU/OK**.

Option	Description
 2 SEC	The shutter is released two seconds after the shutter button is pressed. Use to reduce blur caused by the camera moving when the shutter button is pressed. The self-timer lamp blinks as the timer counts down.
 10 SEC	The shutter is released ten seconds after the shutter button is pressed. Use for photographs in which you wish to appear yourself. The self-timer lamp blinks immediately before the picture is taken.

- 2 Press the shutter button all the way down to start the timer. A count-down timer will appear in the display; the picture will be taken when the timer expires.

FACE AUTO SHUTTER

The picture will be taken when the camera detects a portrait subject facing the lens.

- 1 Highlight  (**FACE AUTO SHUTTER**) in the self-timer menu and press **MENU/OK**.
- 2 Frame a portrait subject in the display. The camera will initiate face detection and release the shutter when the subject is facing the lens.

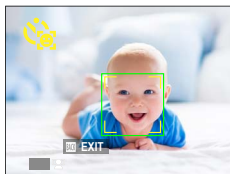



 The camera may fail to detect subjects who are not facing the camera or whose eyes are hidden.

SMILE

The camera releases the shutter when the subject smiles.

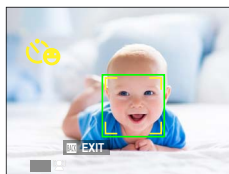
- 1 Highlight  (**SMILE**) in the self-timer menu and press **MENU/OK**.
- 2 Frame portrait subjects in the display. The camera will initiate face detection and release the shutter when any of the subjects smiles.





 The camera may fail to detect subjects who are not facing the camera or whose eyes are obscured by hair or other objects.

BUDDY

The camera takes a picture when it detects two subjects close together.

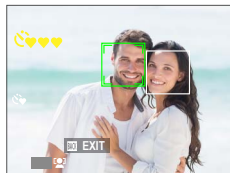

- 1 Highlight  (**BUDDY**) in the self-timer menu and press **MENU/OK**.
- 2 When prompted to choose how close the subjects must be together before the timer starts, highlight the desired option and press **MENU/OK** (the required degree of closeness is shown by heart icons in the shooting display: the more hearts, the closer together the subjects must be).
 - **LV.1 (NEAR):** The timer starts when the subjects are close enough to link hands.
 - **LV.2 (CLOSE UP):** The timer starts when the subjects are shoulder-to-shoulder.
 - **LV.3 (SUPER CLOSE):** The timer starts when the subjects are cheek-to-cheek.



 The timer starts only when the subjects are sufficiently close together; the shutter is released one second later.

GROUP

The camera takes a picture when it detects the selected number of portrait subjects.

- 1 Highlight  (**GROUP**) in the self-timer menu and press **MENU/OK**.
- 2 Highlight the desired number of subjects (1 to 4) and press **MENU/OK** (the number of subjects is indicated by  icons in the shooting display). The timer starts only when the selected number of subjects is in the frame; the shutter is released two seconds later.

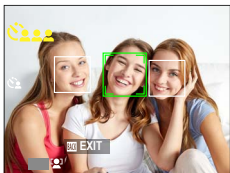





The Shooting Menus

6

SHOOTING MENU (/ /)

Adjust shooting settings.

The shooting menu is displayed when you press **MENU/OK** in shooting mode. Choose from tabs , , or .

 The options available vary with the shooting mode selected.



SHOOTING MODE

Choose a shooting mode according to the type of subject ( 42).

AF/MF SETTING

Adjust focus settings.

FOCUS MODE

Choose how the camera focuses ( 57).

FACE/EYE DETECTION SETTING

Intelligent Face Detection sets focus and exposure for human faces anywhere in the frame, preventing the camera from focusing on the background in group portraits. Choose for shots that emphasize portrait subjects. You can also choose whether the camera detects and focuses on eyes when Intelligent Face Detection is on. Choose from the following options:

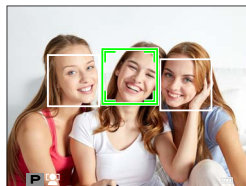

Option	Description
FACE ON/EYE OFF	Intelligent Face Detection only.
FACE ON/EYE AUTO	The camera automatically chooses which eye to focus on when a face is detected.
FACE ON/RIGHT EYE PRIORITY	The camera focuses on the right eye of subjects detected using Intelligent Face Detection.
FACE ON/LEFT EYE PRIORITY	The camera focuses on the left eye of subjects detected using Intelligent Face Detection.
FACE OFF/EYE OFF	Intelligent Face Detection and eye priority off.

- If the subject moves as the shutter button is pressed, the face may not be in the area indicated by the green border when the picture is taken.
 - In some modes, the camera may set exposure for the frame as a whole rather than the portrait subject.
- The face selected by the camera is indicated by a green border.
 - If there is more than one face in the frame, the camera will select the face closest to the center; other faces are indicated by white borders. In **SR+ ADVANCED SR AUTO** mode (but not in other modes), you can select a different face by pressing the selector left.
 - Faces can be detected with the camera in vertical or horizontal orientation.
 - If the camera is unable to detect the subject's eyes because they are hidden by hair, glasses, or other objects, the camera will instead focus on faces.

AF ILLUMINATOR

If **ON** is selected, the AF-assist illuminator will light to assist autofocus.

Options	
ON	OFF

- The AF-assist illuminator turns off automatically when **OFF** is selected for **SOUND & FLASH** in the setup menu.
- The camera may be unable to focus using the AF-assist illuminator in some cases.
- If the camera is unable to focus, try increasing the distance to the subject.
- Avoid shining the AF-assist illuminator directly into your subject's eyes.

RELEASE TYPE

Choose how the shutter button functions when  4K BURST is selected as the burst mode.

Option	Description
WHEN PRESSING	Pictures are taken while the shutter button is pressed.
ON/OFF SWITCH	Shooting starts when the shutter button is pressed and ends when the button is pressed a second time.

ISO

Adjust the camera's sensitivity to light.

Option	Description
AUTO	Sensitivity is adjusted automatically in response to shooting conditions, but will not be raised above the value in parentheses. AUTO is only displayed if AUTO (1600) , AUTO (800) , and AUTO (400) are unavailable.
AUTO (1600)	
AUTO (800)	
AUTO (400)	
12800–100	Adjust sensitivity manually. Selected value is shown in display.

 Sensitivity is not reset when the camera is turned off.

Adjusting Sensitivity

High values can be used to reduce blur when lighting is poor, while lower values allow slower shutter speeds or wider apertures in bright light; note, however, that mottling may appear in pictures taken at high sensitivities.

IMAGE SIZE

Choose the size and aspect ratio at which still pictures are recorded.

Options			
L 4:3 (4608 × 3456)	L 3:2 (4608 × 3072)	L 16:9 (4608 × 2592)	L 1:1 (3456 × 3456)
M 4:3 (3264 × 2448)	M 3:2 (3264 × 2176)	M 16:9 (3264 × 1840)	M 1:1 (2432 × 2432)
S 4:3 (2048 × 1536)	S 3:2 (2304 × 1536)	S 16:9 (1920 × 1080)	S 1:1 (1728 × 1728)

 When pictures are recorded to internal memory, the default value is set to **S 4:3**.

 **IMAGE SIZE** is not reset when the camera is turned off or another shooting mode is selected.

Aspect Ratio

The aspect ratio determines the dimensions of the frame. Choose an option suited to your goals.

Option	Description
4:3	Pictures have the same proportions as the camera display.
3:2	Pictures have the same proportions as a frame of 35 mm film.
16:9	Suited for display on High Definition (HD) devices.
1:1	Pictures are square.

Selecting 1:1

To switch to an aspect ratio of 1:1 before taking pictures, simply press the control to which **SQUARE MODE(1:1)** is assigned ( 115). Press the control again to restore the previously-selected aspect ratio.

Current image size	Image size selected using control to which SQUARE MODE(1:1) is assigned
L 4:3, L 3:2, L 16:9	L 1:1
M 4:3, M 3:2, M 16:9	M 1:1
S 4:3, S 3:2, S 16:9	S 1:1





IMAGE QUALITY



Choose a file format and compression ratio.

Option	Description
FINE	Lower compression ratios are used for higher-quality images.
NORMAL	Higher compression ratios are used to increase the number of images that can be stored.

FINEPIX COLOR

Enhance contrast and color saturation or take pictures in black and white.

Option	Description
 STANDARD	Standard contrast and saturation. Recommended in most situations.
 CHROME	Vivid contrast and color. Choose for vivid shots of flowers or enhanced greens and blues in landscapes.
 B&W	Take pictures in black and white.
 SEPIA	Take pictures in sepia.

-  • Settings other than  **STANDARD** are shown by an icon in the LCD monitor.
- Depending on the subject, the effects of  **CHROME** may not be visible in the LCD monitor.

SELF-TIMER

Use the timer for group- or self-portraits, to prevent blur caused by camera shake, or to release the shutter automatically when selected conditions are met ( 61).

INTERVAL TIMER SHOOTING

Configure the camera to take photos automatically at a preset interval. If desired, frames shot using interval timer shooting can be joined to form a time-lapse movie.

- 1 Highlight  **INTERVAL TIMER SHOOTING** in the shooting menu and press **MENU/OK**.
- 2 Use the selector to choose the interval and number of shots. Press **MENU/OK** to proceed.

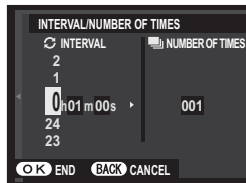

- 3 Highlight one of the following recording types and press **MENU/OK**.
 - **STILL**: Each photo is recorded separately.
 - **STILL+TIME-LAPSE MOVIE**: Each photo is recorded separately; in addition, the entire sequence is recorded as a time-lapse movie.

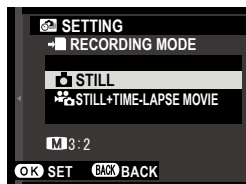

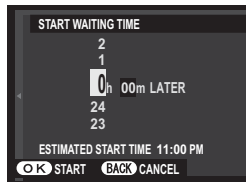

 The frame size and rate for the time-lapse movie can be selected using  **TIME-LAPSE MOVIE MODE** before shooting begins.

- 4 Use the selector to choose the starting time and then press **MENU/OK**.

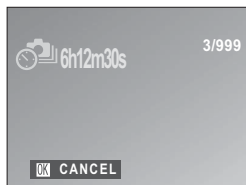

5 Shooting will start automatically.



 Interval timer photography cannot be used during burst, 4K burst, HDR, panorama, or multiple exposure photography.

-  Use of a tripod is recommended.
- The display sometimes turns off between shots and lights a few seconds before the next shot is taken.
- The display can be activated at any time by pressing the shutter button.









Viewing Pictures Taken Using Interval Timer Shooting

Only the first frame of each series will be displayed. Press the selector down to view the other pictures in the series.

-  Pictures taken during interval timer shooting have file names that start with "S".
e.g. S0010001.JPG

TIME-LAPSE MOVIE MODE

Choose the frame size and rate for time-lapse movies.

Option	Frame size	Rate
 2160/15P*	3840 × 2160 (4K)	15 fps
 1080/59.94P  1080/24P	1920 × 1080 (Full HD)	59.94 fps, 50 fps, 24 fps, 23.98 fps
 1080/50P  1080/23.98P		
 720/59.94P  720/24P	1280 × 720 (HD)	
 720/50P  720/23.98P		

* Use a memory card with a UHS speed class of 3 or better when recording time-lapse movies that will be viewed on the camera.

WB WHITE BALANCE

For natural colors, choose a white balance option that matches the light source (📖 60).

⚡ FLASH SET-UP

Adjust flash settings.

FLASH MODE

Choose a flash mode (📖 59).

FLASH COMPENSATION

Adjust flash brightness. Choose from values between +2 EV and -2 EV. Note that the desired results may not be achieved depending on shooting conditions and the distance to the subject.

Options												
+2	+1½	+1¼	+1	+¾	+½	±0	-½	-¾	-1	-1¼	-1½	-2

RED EYE REMOVAL

Choose **ON** to remove red-eye effects caused by the flash.

Options	
ON	OFF

















 Red-eye reduction is performed only when a face is detected.

MOVIE SET-UP

Adjust movie-recording options.

MOVIE MODE

Choose a frame size and rate for movie recording.

Option	Frame size	Rate
 2160/15P ^{1,2}	3840×2160 (4K)	15 fps
 1080/59.94P ¹	1920×1080 (Full HD)	59.94 fps
 1080/50P		50 fps
 1080/24P		24 fps
 1080/23.98P		23.98 fps
 1080 SQUARE 59.94P	1080×1080 (Full HD)	59.94 fps
 1080 SQUARE 50P		50 fps
 1080 SQUARE 24P		24 fps
 1080 SQUARE 23.98P		23.98 fps
 720/59.94P	1280×720 (HD)	59.94 fps
 720/50P		50 fps
 720/24P		24 fps
 720/23.98P		23.98 fps
 720 SQUARE 59.94P	720×720 (HD)	59.94 fps
 720 SQUARE 50P		50 fps
 720 SQUARE 24P		24 fps
 720 SQUARE 23.98P		23.98 fps

1 Electronic vibration reduction is not performed.

2 Use a memory card with a UHS speed class of 3 or better when recording time-lapse movies that will be viewed on the camera.

 The default setting for movies recorded to internal memory is  **2160/15P**.

HD HIGH SPEED VIDEO

Record high-frame-rate HD movies that play back in slow motion, giving you time to view fast-moving subjects or details too fleeting for the naked eye: a batter's swing, darting insects, or swiftly-flowing waters.

Option	Description
1.6× 59.94P 100P	Record HD (1280×720) movies at 1.6×, 2×, 3.3×, or 4× speed and a frame rate of 100 fps. The movies play back at 1/16, 1/2, 1/33, or 1/4 speed, respectively.
2× 50P 100P	
3.3× 29.97P 100P	
4× 25P 100P	
OFF	High-speed recording off.

High-speed movies are recorded at a reduced frame size with no sound. Focus, exposure, and white balance are fixed at the values in effect at the start of recording. Movies shot under low light may be underexposed due to the high recording speeds; we recommend shooting outdoors in daylight or in other brightly-lit locations. If desired, high-speed movies can also be viewed in slow-motion on a computer.

FOCUS MODE

Choose the focus mode for movie recording.

Option	Description
CONTINUOUS AF	The camera focuses using continuous AF.
SINGLE AF	The camera focuses using single AF.





WIND FILTER

Choose whether to enable wind noise reduction during movie recording.

Options	
ON	OFF

IS MODE

Choose from the following image stabilization options:

Option	Description
 CONTINUOUS +MOTION	Image stabilization on. If +MOTION is selected, the camera will adjust shutter speed to reduce motion blur when moving objects are detected.
 CONTINUOUS	
 SHOOTING +MOTION	As above, except that image stabilization is performed only when the shutter is released. If +MOTION is selected, the camera will adjust shutter speed to reduce motion blur when moving objects are detected.
 SHOOTING ONLY	
OFF	Image stabilization off. Choose this option when using a tripod.

 **+MOTION** has no effect when sensitivity is set to a fixed value, and may also be unavailable at some other combinations of settings. The effect may vary with lighting conditions and the speed at which the object is moving.

DIGITAL IMAGE STABILIZER

Choose whether to enable digital image stabilization during movie recording.

Options	
ON	OFF

WIRELESS COMMUNICATION



Connect to smartphones running the latest version of the FUJIFILM Camera Remote app. The smartphone can then be used to:

- Control the camera and take pictures remotely
- Receive pictures uploaded from the camera
- Browse the pictures on the camera and download selected pictures
- Upload location data to the camera



- For downloads and other information, visit:

http://app.fujifilm-dsc.com/en/camera_remote/

- If **WIRELESS COMMUNICATION** is selected for  **CONNECTION SETTING > GENERAL SETTINGS >  BUTTON SETTING**, you can connect to the smartphone during shooting using a function button to which **WIRELESS COMMUNICATION** is assigned ( 114).

INTELLIGENT DIGITAL ZOOM

If **ON** is selected, pressing **T** at the maximum optical zoom position triggers intelligent digital zoom, further magnifying the image while processing it for sharp, high-resolution results.

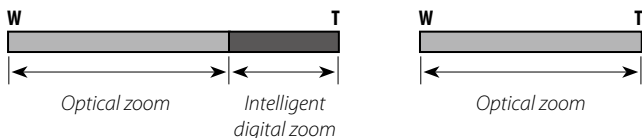

INTELLIGENT DIGITAL ZOOM on

INTELLIGENT DIGITAL ZOOM off

Options

ON

OFF



- Intelligent digital zoom may sometimes produce lower quality images than optical zoom.
- Selecting another mode may end intelligent digital zoom.
- When combined with optical zoom, intelligent digital zoom offers zoom factors as high as 10X.
- The time needed to record images increases.
- The effects are not visible in the display during shooting.
- Intelligent digital zoom is not available in continuous mode or during movie recording.

Playback and the Playback Menu

7

The Playback Display

This section lists the indicators that may be displayed during playback.

! For illustrative purposes, displays are shown with all indicators lit.

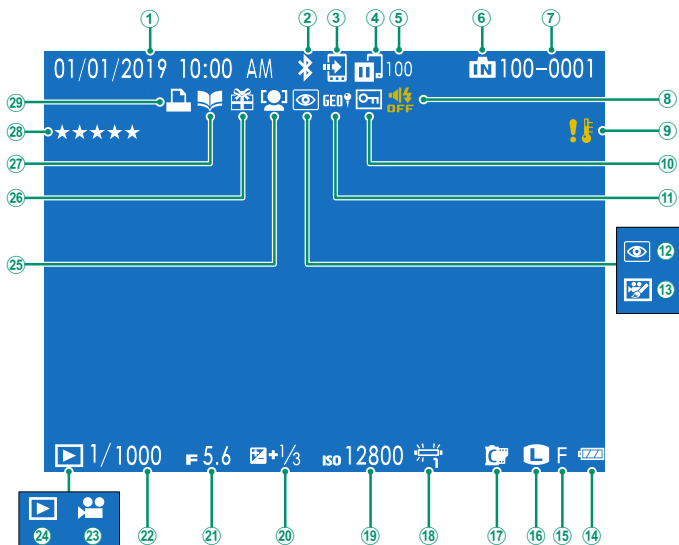

① Date and time.....	25, 100	⑮ Image quality.....	70
② Bluetooth ON/OFF.....	108	⑯ Image size.....	70
③ Image transfer order.....	84	⑰ FINEPIX color.....	70
④ Image transfer status.....	84	⑱ White balance.....	73
⑤ Number of frames selected for upload.....	84	⑲ Sensitivity.....	68
⑥ Internal memory indicator.....		⑳ Exposure compensation.....	52
⑦ Frame number.....	106	㉑ Aperture.....	
⑧ Sound and flash indicator.....	101	㉒ Shutter speed.....	
⑨ Temperature warning.....	154	㉓ Movie icon.....	38
⑩ Protected image.....	92	㉔ Playback mode indicator.....	32
⑪ Location data.....	108, 110	㉕ Face/eye detection setting.....	66
⑫ Red-eye removal indicator.....	93	㉖ Gift image.....	32
⑬ Movie edit.....	89	㉗ Photobook assist indicator.....	94
⑭ Battery level.....	24	㉘ Rating.....	81
		㉙ DPOF print indicator.....	97

The DISP/BACK Button

The **DISP/BACK** button controls the display of indicators during playback.

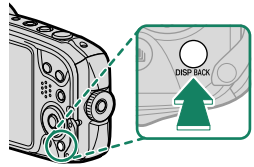

Favorites: Rating Pictures

To rate the current picture, press **DISP/BACK** and press the selector up and down to select from zero to five stars.

Viewing Pictures

Read this section for information on playback zoom and multi-frame playback.

Use the **W** or **T** button to go from full-frame playback to playback zoom or multi-frame playback.

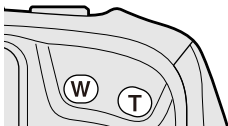

Full-frame playback



Multi-frame playback



Nine-frame view



Hundred-frame view

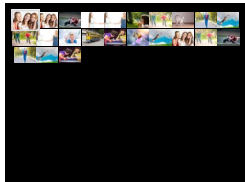

Playback zoom



Medium zoom



Maximum zoom



Press the **DISP/BACK** button to return to full-frame playback.

Playback Zoom

Press **T** to zoom in on pictures displayed in single-frame playback. Press **DISP/BACK** to exit zoom.

- Press **W** to zoom out.
- The maximum zoom ratio varies with the option selected for **IMAGE SIZE**.
- Playback zoom is not available with cropped or resized copies saved at a size of **640**.

Scroll

When the picture is zoomed in, the selector can be used to view areas of the image not currently visible in the display.



Navigation window

Multi-Frame Playback

Press **W** to increase the number of images displayed from 1 to 9 or 9 to 100 (multi-frame playback). The number of pictures displayed decreases each time the **T** button is pressed.

- When two or more images are displayed, use the selector to highlight images and press **MENU/OK** to view the highlighted image full frame.
- In the nine- and hundred-frame displays, use the selector to view more pictures.

The Playback Menu (▶1 / ▶2 / ▶3)

Adjust playback settings.

The playback menu is displayed when you press **MENU/OK** in playback mode. Choose from tabs ▶1, ▶2, or ▶3.

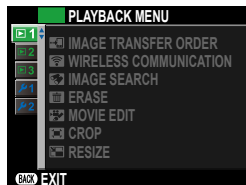

IMAGE TRANSFER ORDER

Select photos for upload to a paired smartphone or tablet.

- 1 Select **IMAGE TRANSFER ORDER** > **SELECT FRAMES** in the playback menu.
- 2 Highlight photos and press **MENU/OK** to select or deselect. Repeat until all the desired photos have been selected.
- 3 Press **DISP/BACK** to exit to playback.

If **ON** is selected for **CONNECTION SETTING** > **Bluetooth SETTINGS** > **Bluetooth ON/OFF**, upload will begin shortly after you exit to playback or turn the camera off.

- Image transfer orders can contain a maximum of 999 pictures.
- The following cannot be selected for upload:
 - Protected pictures
 - Movies
 - "Gift" pictures (pictures taken with other cameras)
- If **PAIRING/TRANSFER ORDER** is selected for **CONNECTION SETTING** > **GENERAL SETTINGS** > **WIRELESS COMMUNICATION** > **WIRELESS COMMUNICATION**, photos can also be marked for upload using the (wireless transfer) button.
- To remove upload marking from all pictures in the current order, select **IMAGE TRANSFER ORDER** > **RESET ORDER**.
- If **ON** is selected for **CONNECTION SETTING** > **Bluetooth SETTINGS** > **AUTO IMAGE TAGGING**, photos will automatically be marked for upload as they are taken.

WIRELESS COMMUNICATION

Connect to smartphones running the latest version of the FUJIFILM Camera Remote app. The smartphone can then be used to:

- Control the camera and take pictures remotely
- Receive pictures uploaded from the camera
- Browse the pictures on the camera and download selected pictures
- Upload location data to the camera



- For downloads and other information, visit:
http://app.fujifilm-dsc.com/en/camera_remote/
- If **WIRELESS COMMUNICATION** is selected for **CONNECTION SETTING > GENERAL SETTINGS >  BUTTON SETTING**, you can connect to the smartphone by pressing the  (wireless transfer) button during playback.

IMAGE SEARCH





Search for pictures.

- 1 Select  **IMAGE SEARCH** in the playback menu, highlight one of the following search criteria, and press **MENU/OK**.

Option	Description
BY DATE	Search by date.
BY FACE	Find all pictures containing faces.
BY ★ FAVORITES	Search by rating.
BY SCENE	Find all pictures that match a selected scene.
BY TYPE OF DATA	Find all still pictures, all movies, or all pictures taken in burst mode.

- 2 Select a search condition. Only pictures that match the search condition will be displayed.

 To delete or protect selected pictures or to view the search results in a slide show, press **MENU/OK** and choose:

-  **ERASE** ( 87)
-  **PROTECT** ( 92)
-  **SLIDE SHOW** ( 93)

ERASE

Delete individual pictures, multiple selected pictures, or all pictures.

 Deleted pictures cannot be recovered. Protect important pictures or copy them to a computer or other storage device before proceeding.

Option	Description
FRAME	Delete pictures one at a time.
SELECTED FRAMES	Delete multiple selected pictures.
ALL FRAMES	Delete all unprotected pictures.

FRAME

- 1 Select **FRAME** for **ERASE** in the playback menu.
- 2 Display the desired picture and press **MENU/OK** to delete.

-  • Pictures are deleted the moment you press the **MENU/OK** button; be careful not to delete pictures accidentally.
- Repeat as necessary to delete additional pictures. Display the picture to be deleted and press **MENU/OK**.

SELECTED FRAMES

- 1 Select **SELECTED FRAMES** for **ERASE** in the playback menu.
- 2 Highlight pictures and press **MENU/OK** to select or deselect (pictures in photobooks or printer orders are shown by **■**). Selected pictures are indicated by check marks (**☑**).
- 3 When the operation is complete, press **DISP/BACK** to display a confirmation dialog.
- 4 Highlight **OK** and press **MENU/OK** to delete the selected pictures.

ALL FRAMES

- 1 Select **ALL FRAMES** for **ERASE** in the playback menu.
- 2 A confirmation dialog will be displayed; highlight **OK** and press **MENU/OK** to delete all unprotected pictures.



- Pressing **DISP/BACK** cancels deletion; note that any pictures deleted before the button was pressed cannot be recovered.
- If a message appears stating that the selected images are part of a DPOF print order, press **MENU/OK** to delete the pictures.
- If a memory card is inserted, only the pictures on the memory card will be affected; the pictures in internal memory are only deleted if no memory card is inserted.

MOVIE EDIT

Edit movies.

MOVIE TRIMMING

Remove opening or ending footage to create an edited copy of the current movie.

- 1 Display the desired movie.
- 2 Select  **MOVIE EDIT** > **MOVIE TRIMMING** in the playback menu. To remove footage from the start of the copy, proceed to Step 3; otherwise, proceed to Step 4.
- 3 Press the selector down to begin playback and press it down again when the new opening frame is reached.
- 4 Press **MENU/OK**. To remove footage from the end of the copy, proceed to Step 5; otherwise, proceed to Step 6.
- 5 Press the selector down to begin playback and press it down again when the new closing frame is reached.
- 6 Press **MENU/OK** to save the copy.

 Do not turn the camera off while editing movies.

MOVIE JOIN

Add existing footage to the end of the current movie to create an edited copy.

- 1 Display the desired movie.
- 2 Select  **MOVIE EDIT** > **MOVIE JOIN** in the playback menu.
- 3 Press the selector left or right to highlight a movie.
- 4 Press **MENU/OK** to add the highlighted footage to the end of the current movie and save the resulting copy, or press **DISP/BACK** to exit without creating a copy.



- Both movies must have been recorded at the same frame size and frame rate.
- Footage cannot be joined if the size of the resulting file would exceed 4 GB.
- Do not turn the camera off while editing movies.

CROP

Create a cropped copy of the current picture.

- 1 Display the desired picture.
- 2 Select  **CROP** in the playback menu.
- 3 Use the zoom buttons to zoom in and out and use the selector to scroll the picture until the desired portion is displayed.
- 4 Press **MENU/OK** to display a confirmation dialog.
- 5 Press **MENU/OK** again to save the cropped copy to a separate file.



- The higher the zoom ratio, the smaller the number of pixels in the cropped copy.
- If the size of the final copy will be **640**, **YES** will be displayed in yellow.

RESIZE

Create a small copy of the current picture.

- 1 Display the desired picture.
- 2 Select  **RESIZE** in the playback menu.
- 3 Highlight a size and press **MENU/OK** to display a confirmation dialog.
- 4 Press **MENU/OK** again to save the resized copy to a separate file.



- The sizes available vary with the size of the original image.

PROTECT

Protect pictures from accidental deletion. Highlight one of the following options and press **MENU/OK**.

Option	Description
FRAME	Protect selected pictures. Press the selector left or right to view pictures and press MENU/OK to select or deselect. Press DISP/BACK when the operation is complete.
SET ALL	Protect all pictures.
RESET ALL	Remove protection from all pictures.





 Protected pictures will be deleted when the memory card or internal memory is formatted.

IMAGE ROTATE

Rotate pictures.

- 1 Display the desired picture.
- 2 Select  **IMAGE ROTATE** in the playback menu.
- 3 Press the selector down to rotate the picture 90° clockwise, up to rotate it 90° counterclockwise.
- 4 Press **MENU/OK**. The picture will automatically be displayed in the selected orientation whenever it is played back on the camera.



 • Protected pictures cannot be rotated. Remove protection before rotating pictures.

- The camera may not be able to rotate pictures created with other devices. Pictures rotated on the camera will not be rotated when viewed on a computer or on other cameras.
- Pictures taken with  **SCREEN SET-UP > AUTOROTATE PB** are automatically displayed in the correct orientation during playback.

RED EYE REMOVAL

Remove red-eye from portraits. The camera will analyze the image; if red-eye is detected, the image will be processed to create a copy with reduced red-eye.

- 1 Display the desired picture.
- 2 Select  **RED EYE REMOVAL** in the playback menu.
- 3 Press **MENU/OK**.

-  • Results vary depending on the scene and the camera's success in detecting faces.
- The amount of time needed to process the image varies with the number of faces detected.
- Red eye cannot be removed from pictures that have already been processed using red-eye removal, which are indicated by a  icon during playback.

SLIDE SHOW

View pictures in an automated slide show. Press **MENU/OK** to start and press the selector right or left to skip ahead or back. Press **DISP/BACK** at any time during the show to view on-screen help. The show can be ended at any time by pressing **MENU/OK**.

-  The camera will not turn off automatically while a slide show is in progress.

PHOTOBOOK ASSIST

Create books from your favorite photos.

Creating a Photobook

- 1 Select **NEW BOOK** for  **PHOTOBOOK ASSIST** in the playback menu.
- 2 Scroll through the images and press the selector up to select or deselect. Press **MENU/OK** to exit when the book is complete.



- Neither photographs **640** or smaller nor movies can be selected for photobooks.
- The first picture selected becomes the cover image. Press the selector down to select the current image for the cover instead.

- 3 Highlight **COMPLETE PHOTOBOOK** and press **MENU/OK** (to select all photos for the book, choose **SELECT ALL**). The new book will be added to the list in the photobook assist menu.



- Books can contain up to 300 pictures.
- Books that contain no photos are automatically deleted.

Photobooks

Photobooks can be copied to a computer using MyFinePix Studio software.

Viewing Photobooks

Select a book in the photobook assist menu to view its contents. Press the selector left or right to scroll through the pictures in the selected book.

Editing and Deleting Photobooks

Display the photobook and press **MENU/OK**. The following options will be displayed; select the desired option and follow the on-screen instructions.

- **EDIT**: Edit the book as described in “Creating a Photobook”.
- **ERASE**: Delete the book.





PC AUTO SAVE

Upload pictures from the camera to a computer running the latest version of FUJIFILM PC AutoSave (note that you must first install the software and configure the computer as a destination for images copied from the camera).

 For downloads and other information, visit:
http://app.fujifilm-dsc.com/en/pc_autosave/

COPY

Copy pictures between internal memory and a memory card.

- 1 Select  **COPY** in the playback menu.
- 2 Highlight one of the following options and press the selector right:
 -  **INTERNAL MEMORY** →  **SD CARD**: Copy pictures from internal memory to a memory card.
 -  **SD CARD** →  **INTERNAL MEMORY**: Copy pictures from a memory card to internal memory.
- 3 Highlight one of the following options and press **MENU/OK**:

- **FRAME**: Copy selected pictures.



Press the selector left or right to view pictures and press **MENU/OK** to copy the current picture.



- **ALL FRAMES**: Copy all pictures.



- Copying ends when the destination is full.
- DPOF print information is not copied.

PRINT ORDER (DPOF)

Create a digital “print order” for DPOF-compatible printers.

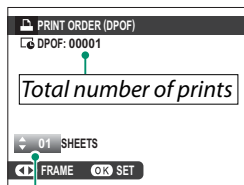

- 1 Select  **PRINT ORDER (DPOF)** in the playback menu.
- 2 Select **WITH DATE**  to print the date of recording on pictures, **WITHOUT DATE** to print pictures without dates, or **RESET ALL** to remove all pictures from the print order before proceeding.
- 3 Display a picture you wish to include in or remove from the print order.
- 4 Press the selector up or down to choose the number of copies (up to 99).

 To remove a picture from the order, press the selector down until the number of copies is 0.



Number of copies

- 5 Repeat steps 3–4 to complete the print order.
- 6 The total number of prints is displayed in the monitor. Press **MENU/OK** to exit.

-  • Remove the memory card to create or modify a print order for the pictures in internal memory.
- The pictures in the current print order are indicated by a  icon during playback.
 - Print orders can contain a maximum of 999 pictures from a single memory card.
 - If a memory card is inserted containing a print order created by another camera, you will need to delete the order before creating as described above.



instax PRINTER PRINT

Print pictures on optional Fujifilm instax SHARE printers (128).

DISP ASPECT

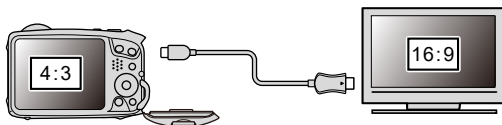
Choose how High Definition (HD) devices display pictures with an aspect ratio of 4:3 (this option is available only when an HDMI cable is connected).



	Option	
	16:9	4:3
Display		

 Select 16:9 to display the image so that it fills the screen with its top and bottom cropped out, 4:3 to display the entire image with black bands at either side.

The Setup Menus

8

The Setup Menu (P1/P2)

Adjust basic camera settings.

To access basic camera settings, press **MENU/OK** and select tab P1 or P2.



🕒 DATE/TIME

Set the camera clock (📖 27).

🕒 TIME DIFFERENCE

Switch the camera clock instantly from your home time zone to the local time at your destination when traveling. To specify the difference between your local and home time zone:

- 1 Highlight **↔ LOCAL** and press **MENU/OK**.
- 2 Use the selector to choose the time difference between local time and your home time zone. Press **MENU/OK** when settings are complete.

To set the camera clock to local time, highlight **↔ LOCAL** and press **MENU/OK**. To set the clock to the time in your home time zone, select **🏠 HOME**.

Options

↔ LOCAL

🏠 HOME

📌 If **↔ LOCAL** is selected, **↔** will be displayed in yellow for about three seconds when the camera is turned on.

言語/LANG.

Choose a language ( 27).

RESET

Reset shooting or setup menu options to default values.

- 1 Highlight the desired option and press **MENU/OK**.

Option	Description
SHOOTING MENU RESET	Reset all shooting menu settings to default values.
SET-UP RESET	Reset all setup menu settings other than  DATE/TIME ,  TIME DIFFERENCE , and  CONNECTION SETTING to default values.

- 2 A confirmation dialog will be displayed; highlight **OK** and press **MENU/OK**.

SOUND & FLASH

Select **OFF** to disable the speaker, flash, and illuminator in situations in which camera sounds or lights may be unwelcome.

Options	
ON	OFF

 appears in the display when **OFF** is selected.

SOUND SET-UP

Adjust sound settings.

OPERATION VOL.

Adjust the volume of the sounds produced when camera controls are operated. Choose OFF to disable control sounds.

Options

 (high)

 (medium)

 (low)

OFF (mute)

SHUTTER VOLUME

Adjust the volume of the sounds produced by the electronic shutter. Choose OFF to disable the shutter sound.

Options

 (high)

 (medium)

 (low)

OFF (mute)

SHUTTER SOUND

Choose the sound made by the electronic shutter.

Options

 1 SOUND 1

 2 SOUND 2

 3 SOUND 3

PLAYBACK VOLUME

Adjust the volume for movie playback. Choose from 10 options between 10 (high) and 1 (low) or select 0 to mute audio during movie playback.

Options

10

9

8

7

6

5

4

3

2

1

0

SCREEN SET-UP

Adjust display settings.

IMAGE DISP.

Choose how long images are displayed after shooting.

Option	Description
CONTINUOUS	Pictures are displayed until the MENU/OK button is pressed or the shutter button is pressed halfway.
1.5 SEC	Pictures are displayed for the selected time or until the shutter button is pressed halfway.
0.5 SEC	
OFF	Pictures are not displayed after shooting.



- Colors may differ slightly from those in the final image.
- “Noise” mottling may be visible at high sensitivities.
- Note that at some settings, the camera will display pictures after shooting regardless of the option selected.

LCD BRIGHTNESS

Adjust monitor brightness.

Options										
+5	+4	+3	+2	+1	0	-1	-2	-3	-4	-5

LCD COLOR

Adjust monitor hue.

Options										
+5	+4	+3	+2	+1	0	-1	-2	-3	-4	-5

FRAMING GUIDELINE

Choose a framing grid for shooting mode.

		Option		
		GRID 9	GRID 24	HD FRAMING
Display				
	<p>For “rule of thirds” composition.</p>	<p>A six-by-four grid.</p>	<p>Frame HD pictures in the crop shown by the lines at the top and bottom of the display.</p>	

Framing guides are not shown at default settings but can be displayed using **SCREEN SET-UP > DISP. CUSTOM SETTING** (9).

AUTOROTATE PB

Choose **ON** to automatically rotate “tall” (portrait-orientation) pictures during playback.

Options	
ON	OFF

DISP. CUSTOM SETTING

Choose items for the standard display (9).

Fn FUNCTION (Fn) SETTING

Choose the roles assigned to the left (**Fn**/function, ①), right (⚡/flash, ②), and down (⌚/self-timer, ③) buttons on the selector (📖 115).

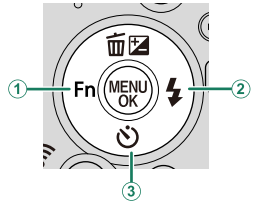

PM POWER MANAGEMENT

Adjust power management settings.

AUTO POWER OFF

Choose the length of time before the camera turns off automatically when no operations are performed. Shorter times increase battery life; if **OFF** is selected, the camera must be turned off manually.

Options		
5 MIN	2 MIN	OFF

HIGH PERFORMANCE

Select **ON** for faster focus and to reduce the time needed to restart the camera.

Options	
ON	OFF

SAVE DATA SET-UP

Adjust file management settings.

FRAME NO.

New pictures are stored in image files named using a four-digit file number assigned by adding one to the last file number used. The file number is displayed during playback as shown. **FRAME NO.** controls whether file numbering is reset to 0001 when a new memory card is inserted or the current memory card or internal memory is formatted.

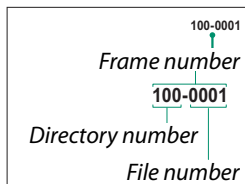





Option	Description
CONTINUOUS	Numbering continues from the last file number used or the first available file number, whichever is higher. Choose this option to reduce the number of pictures with duplicate file names.
RENEW	Numbering is reset to 0001 after formatting or when a new memory card is inserted.

- If the frame number reaches 999-9999, the shutter release will be disabled. Format the memory card after transferring to a computer any pictures you wish to keep.
- Selecting **RESET** sets **FRAME NO.** to **CONTINUOUS** but does not reset the file number.
- Frame numbers for pictures taken with other cameras may differ.

DATE STAMP

Stamp the time and/or date of recording on photographs as they are taken.

Option	Description
 + ⊖	Stamp new photographs with the date and time of recording.
	Stamp new photographs with the date of recording.
OFF	Do not stamp the time and date on new photographs.

- Time and date stamps cannot be deleted. Turn **DATE STAMP** off to prevent time and date stamps appearing on new photographs.
- If the camera clock is not set, you will be prompted to set the clock to the current date and time ( 25, 27).
- We recommend that you turn the DPOF “print date” option off when printing images with a time and date stamp ( 97).
- Time and date stamps do not appear on movies or panoramas or on shots taken using 4K burst.

CONNECTION SETTING

Adjust settings for connection to wireless devices, including smartphones, computers, and Fujifilm instax SHARE printers.



For more information on wireless connections, visit:

<http://fujifilm-dsc.com/wifi/>

Bluetooth SETTINGS

Adjust Bluetooth settings.

Option	Description
PAIRING REGISTRATION	To pair the camera with a smartphone or tablet, select this option, then launch FUJIFILM Camera Remote on the smart device and tap PAIRING REGISTRATION .
SELECT PAIRING DESTINATION	Choose a connection from a list of devices with which the camera has been paired using PAIRING REGISTRATION . Select NO CONNECTION to exit without connecting.
DELETE PAIRING REG.	Delete pairing information for selected devices. Choose the device in the device list. The selected device will also be removed from the devices listed in SELECT PAIRING DESTINATION .
Bluetooth ON/OFF	<ul style="list-style-type: none">• ON: The camera automatically establishes a Bluetooth connection with paired devices when turned on.• OFF: The camera does not connect via Bluetooth.
AUTO IMAGE TAGGING	<ul style="list-style-type: none">• ON: Mark JPEG images for upload as they are taken.• OFF: Photos are not marked for upload as they are taken.
SEAMLESS TRANSFER	<ul style="list-style-type: none">• ON: Pictures are uploaded to paired devices during playback, while the camera is off, and after shooting.• OFF: Pictures are uploaded to paired devices only when the camera is off or starting shortly after you exit to playback.
SMARTPHONE SYNC. SETTING	Choose whether to synchronize the camera to the time and/or location provided by a paired smartphone. <ul style="list-style-type: none">• LOCATION&TIME: Synchronize the time and location.• LOCATION: Synchronize the location.• TIME: Synchronize the time.• OFF: Synchronization off.

- Install the latest version of the FUJIFILM Camera Remote app on your smartphone or tablet before pairing the device with your camera or uploading images.
- When **ON** is selected for both **Bluetooth ON/OFF** and **AUTO IMAGE TAGGING** and **OFF** is chosen for **SEAMLESS TRANSFER**, upload to paired devices will begin when the camera is turned off or shortly after you exit to playback.
- If **AUTO IMAGE TAGGING** is off, pictures can be marked for transfer using the  **IMAGE TRANSFER ORDER** option in the playback menu.

PC AUTO SAVE

Adjust settings for connection to computers via wireless LAN.

Option	Description
PC AUTO SAVE SETTING	Choose the method used for connection to computers via a wireless LAN. <ul style="list-style-type: none"> • SIMPLE SETUP: Connect using WPS. • MANUAL SETUP: Choose the network from a list (SELECT FROM NETWORK LIST) or enter the name manually (ENTER SSID).
DELETE REGISTERED DESTINATION PC	Remove selected destinations.
DETAILS OF PREVIOUS CONNECTION	View computers to which the camera has recently connected.

instax PRINTER CONNECTION SETTING

Adjust settings for connection to optional Fujifilm instax SHARE printers.



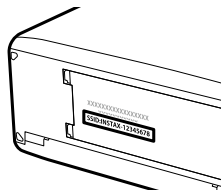

The Printer Name (SSID) and Password

The printer name (SSID) can be found on the bottom of the printer; the default password is "1111". If you have already chosen a different password to print from a smartphone, enter that password instead.



GENERAL SETTINGS

Adjust settings for connection to wireless networks.

Option	Description
NAME	Choose a name (NAME) to identify the camera on the wireless network (the camera is assigned a unique name by default).
RESIZE IMAGE FOR SMARTPHONE 	Choose whether to resize images for upload to smartphones. Resizing applies only to the copy uploaded to the smartphone; the original is not affected. <ul style="list-style-type: none"> • ON: Larger images are resized to  for upload. This setting is recommended. • OFF: Images are uploaded at their original size.
GEOTAGGING	Choose whether location data downloaded from a smartphone are embedded in pictures as they are taken.
LOCATION INFO	Display the location data last downloaded from a smartphone.
 BUTTON SETTING	Choose the role played by the  (wireless transfer) button during playback or during shooting by the Fn button when it is assigned the WIRELESS COMMUNICATION function. <ul style="list-style-type: none"> • PAIRING/TRANSFER ORDER: If the camera is not currently paired with another device, Bluetooth pairing options will be displayed. Otherwise transfer options will be displayed. • WIRELESS COMMUNICATION: The button functions as a wireless communication button.

INFORMATION

View the camera's MAC and Bluetooth address.

RESET WIRELESS SETTING

Restore wireless settings to their default values.

FORMAT

If a memory card is inserted in the camera, this option will format the memory card. If no memory card is inserted, this option will format internal memory.

- 1 Highlight  **FORMAT** in the setup menu and press **MENU/OK**.
- 2 A confirmation dialog will be displayed. Highlight **OK** and press **MENU/OK** to format the memory card or internal memory.

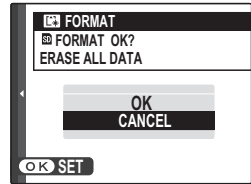

 To exit without formatting the memory card or internal memory, select **CANCEL** or press **DISP/BACK**.

-  All data—including protected pictures—will be deleted from the memory card or internal memory. Be sure important files have been copied to a computer or other storage device.
- Do not open the battery-chamber cover during formatting.

Shortcuts

9

The Fn (Function) Buttons

Assign a role to the function buttons for quick access to the selected feature.

The default assignments are:

Fn (function) button

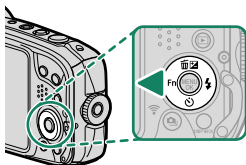

Advanced filter

⚡ (flash) button

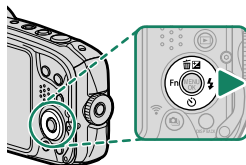

Flash mode

⌚ (self-timer) button

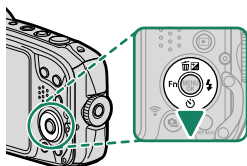

Self-timer

Assigning a Role to the Function Buttons

The roles assigned to the function buttons can be selected using the **Fn FUNCTION (Fn) SETTING** item in the setup menu. The following options are available.

- ISO
- SELF-TIMER
- IMAGE SIZE
- SQUARE MODE(1:1)
- IMAGE QUALITY
- ADVANCED FILTER
- FINEPIX COLOR
- WHITE BALANCE
- FOCUS MODE
- FOCUS AREA
- PORTRAIT ENHANCER LV
- FLASH MODE
- FLASH COMPENSATION
- MOVIE MODE
- FACE/EYE DETECTION SETTING
- WIRELESS COMMUNICATION
- AUTO IMAGE TAGGING
- SELECT PAIRING DESTINATION
- Bluetooth ON/OFF
- NONE



- To disable the function button, choose **NONE**.
- Role selection can also be accessed by pressing and holding the function or **DISP/BACK** button.
- Pressing the button to which advanced filters are assigned displays filter selection options. Highlight a filter and press **MENU/OK** to select. To exit advanced filter mode, choose another shooting mode or press the **DISP/BACK** button to return to the previously-selected mode.

Optional Accessories

10

Accessories from Fujifilm

The following optional accessories are available from Fujifilm. For the latest information on the accessories available in your region, check with your local Fujifilm representative or visit http://www.fujifilm.com/products/digital_cameras/index.html.

Rechargeable Li-ion batteries

NP-45S: Additional NP-45S rechargeable batteries can be purchased as required.

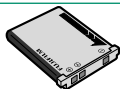

instax SHARE printers

SP-1/SP-2/SP-3: Connect via wireless LAN to print pictures on instax film.

Connections

11

HDMI Output

Camera playback displays can be output to HDMI devices via a third-party HDMI cable.

Connecting to HDMI Devices

Connect the camera to TVs or other HDMI devices using a third-party HDMI cable.

- 1 Turn the camera off.
- 2 Connect the cable as shown below.

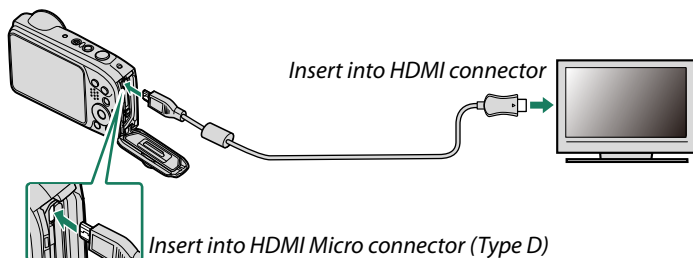

- 3 Configure the device for HDMI input as described in the documentation supplied with the device.
- 4 Press the  button for about a second to turn the camera on. The camera monitor turns off and pictures and movies are played back on the TV.

- ! Making sure the connectors are fully inserted.
- The USB cable cannot be used while an HDMI cable is connected.
- Use an HDMI cable no more than 1.5 m (4.9 ft.) long.



- When an HDMI cable is connected, pictures and sound are played back on the TV.
- Some televisions may briefly display a black screen when movie playback begins.
- Note that the camera volume controls have no effect on sounds played on the TV; use the television volume controls to adjust the volume.

Wireless Connections (Bluetooth®, Wireless LAN/Wi-Fi)

Access wireless networks and connect to computers, smartphones, or tablets. For more information, visit:

<http://fujifilm-dsc.com/wifi/>

Smart Phones and Tablets: FUJIFILM Camera Remote

Connect to the camera via Bluetooth or wireless LAN.

 To establish a wireless connection to the camera, you will need to install the latest version of the FUJIFILM Camera Remote app on your smartphone or tablet.

FUJIFILM Camera Remote

Once a connection has been established, you can use FUJIFILM Camera Remote to:

- Control the camera and take pictures remotely
- Receive pictures uploaded from the camera
- Browse the pictures on the camera and download selected pictures
- Upload location data to the camera
- Release the camera shutter
- Update camera firmware

For downloads and other information, visit:

http://app.fujifilm-dsc.com/en/camera_remote/

Smart Phones and Tablets: Bluetooth® Pairing

Use **📶 CONNECTION SETTING > Bluetooth SETTINGS > PAIRING REGISTRATION** to pair the camera with smartphones or tablets. Pairing offers a simple method for downloading photos from the camera.



- Photos are downloaded via a wireless connection.
- Once pairing is complete, you will be able to synchronize the camera clock and location data with the smartphone or tablet (📖 108).
- Pairing can also be performed by pressing the **📶** (wireless transfer) button during playback or by pressing the button to which **PAIRING/TRANSFER ORDER** has been assigned using **📶 CONNECTION SETTING > GENERAL SETTINGS > 📶 BUTTON SETTING** (📖 114). Once pairing is complete, these buttons display transfer options.

Smartphones and Tablets: Wi-Fi

Use the **📶 WIRELESS COMMUNICATION** options in the shooting menu or the playback menu to connect to a smartphone or tablet via Wi-Fi.



- Wi-Fi connections can also be initiated by pressing the **📶** (wireless transfer) button during playback or by pressing the button to which **WIRELESS COMMUNICATION** has been assigned using **📶 CONNECTION SETTING > GENERAL SETTINGS > 📶 BUTTON SETTING** (📖 114).

Copying Pictures to a Computer: PC AutoSave

Install the latest version of FUJIFILM PC AutoSave to your computer to upload pictures from the camera over wireless networks (Wi-Fi).

FUJIFILM PC AutoSave

For downloads and other information, visit:
http://app.fujifilm-dsc.com/en/pc_autosave/

Computers: Wireless Connections

You can upload pictures from the camera using the  **PC AUTO SAVE** option in the playback menu.

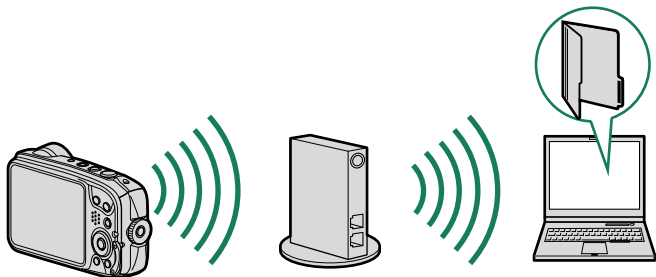

Connecting to Computers via USB

Connect the camera to a computer to download pictures.

Windows (MyFinePix Studio)

Use MyFinePix Studio to copy pictures to your computer, where they can be stored, viewed, organized, and printed. MyFinePix Studio is available for download from the following website:

<http://fujifilm-dsc.com/mfs/>

Once download is complete, double-click the downloaded file ("MFPS_Setup.EXE") and follow the on-screen instructions to complete installation.

Mac OS X/macOS

Pictures can be copied to your computer using Image Capture (supplied with your computer) or other software.

 Use a card reader to copy files over 4 GB in size.

Connecting the Camera

Connect the camera and computer using the supplied USB cable.

- 1 Start the computer.
- 2 Turn the camera off and connect the supplied USB cable as shown, making sure the connectors are fully inserted.

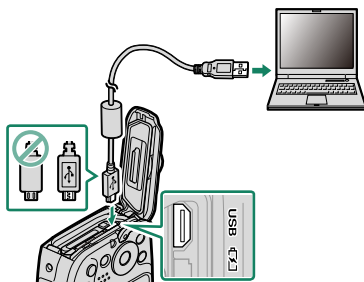

! The camera is equipped with a Micro USB (Micro-B) USB 2.0 connector.

- 3 Press the **▶** button for about a second to turn the camera on.
- 4 Copy pictures to the computer using MyFinePix Studio or applications provided with your operating system.
- 5 When transfer is complete, turn the camera off and disconnect the USB cable.

- ❗ • When connecting USB cables, be sure the connectors are fully inserted in the correct orientation. Connect the camera directly to the computer; do not use a USB hub or keyboard.
- Loss of power during transfer could result in loss of data or damage to internal memory or the memory card. Charge the battery before connecting the camera.
- To transfer pictures from internal memory, remove the memory card from the camera.
- If a memory card containing a large number of images is inserted, there may be a delay before the software starts and you may be unable to import or save images. Use a memory card reader to transfer pictures.
- Do not disconnect the USB cable while transfer is in progress. Failure to observe this precaution could result in loss of data or damage to internal memory or the memory card.
- Disconnect the camera before inserting or removing memory cards.
- In some cases, it may not be possible to access pictures saved to a network server using the software in the same way as on a stand-alone computer.
- Do not immediately remove the camera from the system or disconnect the USB cable once the message stating that copying is in progress clears from the computer display. If the number of images copied is very large, data transfer may continue after the message has ceased to be displayed.
- The user bears all applicable fees charged by the phone company or Internet service provider when using services that require an Internet connection.

instax SHARE Printers

Print pictures from your digital camera to instax SHARE printers.

Establishing a Connection

Select  **CONNECTION SETTING** > **instax PRINTER CONNECTION SETTING** in the camera setup menu and enter the instax SHARE printer name (SSID) and password.

The Printer Name (SSID) and Password

The printer name (SSID) can be found on the bottom of the printer; the default password is "1111". If you have already chosen a different password to print from a smartphone, enter that password instead.

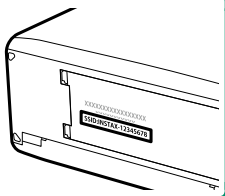

Printing Pictures

- 1 Turn the printer on.
- 2 Select  **instax PRINTER PRINT** in the camera playback menu. The camera will connect to the printer.

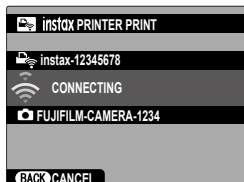

- 3 Display the picture you want to print, then press **MENU/OK**.



-  Pictures taken with other cameras cannot be printed.
- The area printed is smaller than the area visible in the LCD monitor.
- The displays may vary depending on the printer connected.

- 4 The picture will be sent to the printer and printing will start.

12

Technical Notes

Software from Fujifilm

The camera can be used with the following Fujifilm software.

FUJIFILM Camera Remote

Establish a wireless connection between your camera and a smartphone or tablet (📖 122).

http://app.fujifilm-dsc.com/en/camera_remote/

FUJIFILM PC AutoSave

Download pictures from your camera over wireless networks (📖 124).

http://app.fujifilm-dsc.com/en/pc_autosave/

MyFinePix Studio

Manage, view, print, and edit the many images downloaded from your digital camera (📖 125).

<http://fujifilm-dsc.com/mfs/>

For Your Safety

IMPORTANT SAFETY INSTRUCTIONS

- **Read Instructions:** All the safety and operating instructions should be read before the appliance is operated.
- **Retain Instructions:** The safety and operating instructions should be retained for future reference.
- **Heed Warnings:** All warnings on the appliance and in the operating instructions should be adhered to.
- **Follow Instructions:** All operating and use instructions should be followed.

Installation

Power Sources: This video product should be operated only from the type of power source indicated on the marking label. If you are not sure of the type of power supply to your home, consult your appliance dealer or local power company. For video products intended to operate from battery power, or other sources, refer to the operating instructions.

Grounding or Polarization: This video product is equipped with a polarized alternating-current line plug (a plug having one blade wider than the other). This plug will fit into the power outlet only one way. This is a safety feature. If you are unable to insert the plug fully into the outlet, try reversing the plug. If the plug should still fail to fit, contact your electrician to replace your obsolete outlet. Do not defeat the safety purpose of the polarized plug.

Alternate Warnings: This video product is equipped with a three-wire grounding-type plug, a plug having a third (grounding) pin. This plug will only fit into a grounding-type power outlet. This is a safety feature. If you are unable to insert the plug into the outlet, contact your electrician to replace your obsolete outlet. Do not defeat the safety purpose of the grounding type plug.

Overloading: Do not overload wall outlets and extension cords as this can result in a risk of fire or electric shock.

Ventilation: Slots and openings in the cabinet are provided for ventilation, to ensure reliable operation of the video product and to protect it from overheating, and these openings must not be blocked or covered. The openings should never be blocked by placing the video product on a bed, sofa, rug, or other similar surface.

This video product should not be placed in a built-in installation such as a bookcase or rack unless proper ventilation is provided or the manufacturer's instructions have been adhered to. This video product should never be placed near or over a radiator or heat register.

Attachments: Do not use attachments not recommended by the video product manufacturer as they may cause hazards.

Water and Moisture: Do not use this video product near water—for example, near a bath tub, wash bowl, kitchen sink, or laundry tub, in a wet basement, or near a swimming pool, and the like.

Power-Cord Protection: Power-supply cords should be routed so that they are not likely to be walked on or pinched by items placed upon or against them, paying particular attention to cords at plugs, convenience receptacles, and the point where they exit from the appliance.

Accessories: Do not place this video product on an unstable cart, stand, tripod, bracket, or table. The video product may fall, causing serious injury to a child or adult, and serious damage to the appliance. Use only with a cart, stand, tripod, bracket, or table recommended by the manufacturer, or sold with the video product. Any mounting of the appliance should follow the manufacturer's instructions, and should use a mounting accessory recommended by the manufacturer.

An appliance and cart combination should be moved with care. Quick stops, excessive force, and uneven surfaces may cause the appliance and cart combination to overturn.



Antennas

Outdoor Antenna Grounding: If an outside antenna or cable system is connected to the video product, be sure the antenna or cable system is grounded so as to provide some protection against voltage surges and built-up static charges. Section 810 of the National Electrical Code, ANSI/NFPA No. 70, provides information with respect to proper grounding of the mast and supporting structure, grounding of the lead-in wire to an antenna discharge unit, size of grounding conductors, location of antenna discharge unit, connection to grounding electrodes, and requirements for the grounding electrode.

EXAMPLE OF ANTENNA GROUNDING AS PER NATIONAL ELECTRICAL CODE

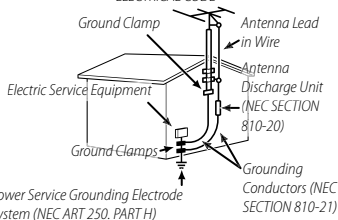

Power Lines: An outside antenna system should not be located in the vicinity of overhead power lines or other electric light or power circuits, or where it can fall into such power lines or circuits. When installing an outside antenna system, extreme care should be taken to keep from touching such power lines or circuits as contact with them might be fatal.

Use

Cleaning: Unplug this video product from the wall outlet before cleaning. Do not use liquid cleaners or aerosol cleaners. Use a damp cloth for cleaning.

Object and Liquid Entry: Never push objects of any kind into this video product through openings as they may touch dangerous voltage points or short out parts that could result in a fire or electric shock. Never spill liquid of any kind on the video product.

Lightning: For added protection for this video product receiver during a lightning storm, or when it is left unattended and unused for long periods of time, unplug it from the wall outlet and disconnect the antenna or cable system. This will prevent damage to the video product due to lightning and power-line surges.

Service

Service: Do not attempt to service this video product yourself as opening or removing covers may expose you to dangerous voltage or other hazards. Refer all servicing to qualified service personnel.

Damage Requiring Service: Unplug this video product from the wall outlet and refer servicing to qualified service personnel under the following conditions:

- When the power-supply cord or plug is damaged
- If liquid has been spilled, or objects have fallen into the video product.
- If the video product has been exposed to rain or water.
- If the video product has been dropped or the cabinet has been damaged.

If the video product does not operate normally follow the operating instructions. Adjust only those controls that are covered by the operating instructions as an improper adjustment of other controls may result in damage and will often require extensive work by a qualified technician to restore the video product to its normal operation.

When the video product exhibits a distinct change in performance — this indicates a need for service.

Replacement Parts: When replacement parts are required, be sure the service technician has used replacement parts specified by the manufacturer or have the same characteristics as the original part. Unauthorized substitutions may result in fire, electric shock or other hazards.

Safety Check: Upon completion of any service or repairs to this video product, ask the service technician to perform safety checks to determine that the video product is in proper operating condition.



Be sure to read these notes before use

Safety Notes



- Make sure that you use your camera correctly. Read these safety notes and your *Owner's Manual* carefully before use.
- After reading these safety notes, store them in a safe place.

About the Icons



The icons shown below are used in this document to indicate the severity of the injury or damage that can result if the information indicated by the icon is ignored and the product is used incorrectly as a result.

	WARNING	This icon indicates that death or serious injury can result if the information is ignored.
	CAUTION	This icon indicates that personal injury or material damage can result if the information is ignored.

The icons shown below are used to indicate the nature of the instructions which are to be observed.

	Triangular icons tell you that this information requires attention ("Important").
	Circular icons with a diagonal bar tell you that the action indicated is prohibited ("Prohibited").
	Filled circles with an exclamation mark indicate an action that must be performed ("Required").

The symbols on the product (including the accessories) represent the following:

	AC
	DC
	Class II equipment (The construction of the product is double-insulated.)













WARNING















If a problem arises, turn the camera off, remove the battery, disconnect the USB cable, and unplug the AC power adapter. Continued use of the camera when it is emitting smoke, is emitting any unusual odor, or is in any other abnormal state can cause a fire or electric shock. Contact your Fujifilm dealer.





Do not allow water or foreign objects to enter the camera or connecting cables. Do not use the camera or connecting cables following ingress of fresh or salt water, milk, beverages, detergents, or other liquids. Should liquid find its way into the camera or connecting cables, turn the camera off, remove the battery, disconnect the USB cable, and disconnect and unplug the AC adapter. Continued use of the camera can cause a fire or electric shock. Contact your Fujifilm dealer.













 WARNING	
	Do not use the camera in the bathroom or shower (excluding waterproof products). This can cause a fire or electric shock.
	Never attempt to change or take apart the camera (never open the case). Failure to observe this precaution can cause fire or electric shock.
	Should the case break open as the result of a fall or other accident, do not touch the exposed parts. Failure to observe this precaution could result in electric shock or in injury from touching the damaged parts. Remove the battery immediately, taking care to avoid injury or electric shock, and take the product to the point of purchase for consultation.
	Do not change, heat or unduly twist or pull the connection cord and do not place heavy objects on the connection cord. These actions could damage the cord and cause a fire or electric shock. If the cord is damaged, contact your Fujifilm dealer. Do not use cables with bent connectors.
	Do not place the camera on an unstable surface. This can cause the camera to fall or tip over and cause injury.
	Never attempt to take pictures while in motion. Do not use the camera while walking or driving. This can result in you falling down or being involved in a traffic accident.
	Do not touch any metal parts of the camera during a thunderstorm. This can cause an electric shock due to induced current from the lightning discharge.
	Do not use the battery except as specified. Load the battery as shown by the indicator.
	Do not disassemble, modify, or heat batteries. Do not drop, strike, or throw batteries or otherwise subject them to strong impacts. Do not use batteries that show signs of leaking, deformation, discoloration, or other abnormalities. Use only designated chargers to recharge rechargeable batteries and do not attempt to recharge non-rechargeable Li-ion or alkaline batteries. Do not short batteries or store them with metallic objects. Failure to observe these precautions could result in the batteries overheating, igniting, rupturing, or leaking, causing fire, burns, or other injury.
	Use only batteries or AC power adapters specified for use with this camera. Do not use voltages other than the power supply voltage shown. The use of other power sources can cause a fire.
	If the battery leaks and fluid gets in contact with your eyes, skin or clothing, flush the affected area with clean water and seek medical attention or call an emergency number right away.

 WARNING	
	Do not use the charger to charge batteries other than those specified here. The supplied charger is for use only with batteries of the type supplied with the camera. Using the charger to charge conventional batteries or other types of rechargeable batteries can cause the battery to leak, overheat or burst.
	Using a flash too close to a person's eyes may cause visual impairment. Take particular care when photographing infants and young children.
	Do not remain in prolonged contact with hot surfaces. Failure to observe this precaution could result in low-temperature burns, particularly at high ambient temperatures or with users who suffer from poor circulation or reduced sensation, in which case use of a tripod or similar precautions are recommended.
	Do not leave one part of the body in contact with the product for prolonged periods while the product is on. Failure to observe this precaution could result in low-temperature burns, particularly during prolonged use, at high ambient temperatures, or with users who suffer from poor circulation or reduced sensation, in which case use of a tripod or similar precautions are recommended.
	Do not use in the presence of flammable objects, explosive gases, or dust.
	When carrying the battery, install it in a digital camera or keep it in the hard case. When storing the battery, keep it in the hard case. When discarding, cover the battery terminals with insulation tape. Contact with other metallic objects or batteries could cause the battery to ignite or burst.
	Keep memory cards, hot shoes, and other small parts out of the reach of small children. Children may swallow small parts; keep out of reach of children. Should a child swallow a small part, seek medical attention or call emergency.
	Turn the camera off in crowds. The camera emits radio-frequency radiation that may interfere with pacemakers.
	Turn the camera off in the vicinity of automatic doors, public address systems, and other automatically controlled devices. The camera emits radio-frequency radiation that may cause these devices to malfunction.
	Keep the camera at least 22 cm (0.7 ft.) away from people wearing pacemakers. The camera emits radio-frequency radiation that may interfere with pacemakers.
	Keep out of reach of small children. Among the elements that could cause injury are the strap, which could become entangled about a child's neck, causing strangulation, and the flash, which could cause visual impairment.





 **WARNING**

-  **Do not view the sun through the lens or camera viewfinders.** Failure to observe this precaution can cause permanent visual impairment.
-  **Using a flash too close to a person's eyes may temporarily affect the eyesight.** There is a risk of visual impairment. When using the flash to photograph a child or infant, take special care to keep enough distance.
-  **Follow the directions of airline and hospital personnel.** This product generates radio-frequency emissions that could interfere with navigational or medical equipment.

 **CAUTION**

-  **Do not use this camera in locations affected by oil fumes, steam, humidity or dust.** This can cause a fire or electric shock.
-  **Do not leave this camera in places subject to extremely high temperatures.** Do not leave the camera in locations such as a sealed vehicle or in direct sunlight. This can cause a fire.
-  **Do not place heavy objects on the camera.** This can cause the heavy object to tip over or fall and cause injury.
-  **Do not move the camera while the AC power adapter is still connected.** Do not pull on the connection cord to disconnect the AC power adapter. This can damage the power cord or cables and cause a fire or electric shock.
-  **Do not cover or wrap the camera or the AC power adapter in a cloth or blanket.** This can cause heat to build up and distort the casing or cause a fire.
-  **Do not use the plug if it is damaged or if it does not fit securely into the outlet.** Failure to observe this precaution could result in fire or electric shock.
-  **When you are cleaning the camera or you do not plan to use the camera for an extended period, remove the battery and disconnect and unplug the AC power adapter.** Failure to do so can cause a fire or electric shock.
-  **When charging ends, unplug the charger from the power socket.** Leaving the charger plugged into the power socket can cause a fire.
-  **When a memory card is removed, the card could come out of the slot too quickly. Use your finger to hold it and gently release the card.** Injury could result to those struck by the ejected card.
-  **Request regular internal testing and cleaning for your camera.** Build-up of dust in your camera can cause a fire or electric shock. Contact your Fujifilm dealer to request internal cleaning every two years. Please note that this service is not free of charge.
-  **Danger of explosion if battery is incorrectly replaced. Replace only with the same or equivalent type.**
-  **Batteries (battery pack or batteries installed) shall not be exposed to excessive heat such as sunshine, fire or the like.**

 **CAUTION**

-  **Remove your fingers from the flash window before the flash fires.** Failure to observe this precaution could result in burns.
-  **Keep the flash window clean and do not use the flash if the window is obstructed.** Failure to observe these precautions could cause smoke or discoloration.
-  **Keep the sun out of the frame when shooting backlit subjects.** Sunlight focused into the camera when the sun is in or close to the frame can cause fire or burns.
-  **Do not carry the camera or lens while they are attached to a tripod.** The product can fall or strike other objects, causing injury.

The Battery and Power Supply

Note: Check the type of battery used in your camera and read the appropriate sections.

⚠ WARNING: Battery shall not be exposed to excessive heat such as sunshine, fire or the like.

The following describes the proper use of batteries and how to prolong their life. Incorrect use can shorten battery life or cause leakage, overheating, fire, or explosion.

Li-ion Batteries

Read this section if your camera uses a rechargeable Li-ion battery.

The battery is not charged at shipment. Charge the battery before use. Keep the battery in its case when not in use.

■ Notes on the Battery

The battery gradually loses its charge when not in use. Charge the battery one or two days before use.

Battery life can be extended by turning the camera off when not in use.

Battery capacity decreases at low temperatures; a depleted battery may not function when cold. Keep a fully charged spare battery in a warm place and exchange as necessary, or keep the battery in your pocket or other warm place and insert it in the camera only when shooting. Do not place the battery in direct contact with hand warmers or other heating devices.

■ Charging the Battery

Charging times will increase at ambient temperatures below +10°C (+50°F) or above +35°C (+95°F). Do not attempt to charge the battery at temperatures above +40°C (+104°F); at temperatures below 0°C (+32°F), the battery will not charge.

Do not attempt to recharge a fully charged battery. The battery does not however need to be fully discharged before charging.

The battery may be warm to the touch immediately after charging or use. This is normal.

■ Battery Life

At normal temperatures, the battery can be recharged about 300 times. A noticeable decrease in the length of time the battery will hold a charge indicates that it has reached the end of its service life and should be replaced.

■ Storage

Performance may be impaired if the battery is left unused for extended periods when fully charged. Run the battery flat before storing it.

If the camera will not be used for an extended period, remove the battery and store it in a dry place with an ambient temperature of from +15°C to +25°C (+59°F to +77°F). Do not store in locations exposed to extremes of temperature.

■ Cautions: Handling the Battery

- Do not transport or store with metal objects such as necklaces or hairpins.
- Do not expose to flame or heat.
- Do not disassemble or modify.
- Use with designated chargers only.
- Dispose of used batteries promptly.
- Do not drop or subject to strong physical shocks.
- Do not expose to water.
- Keep the terminals clean.
- The battery and camera body may become warm to the touch after extended use. This is normal.

■ Caution: Disposal

Dispose of used batteries in accord with local regulations. Attention should be drawn to the environmental aspects of battery disposal. Use the apparatus under moderate climate.

AC Power Adapters

Use only Fujifilm AC power adapters designated for use with this camera. Other adapters could damage the camera.

- The AC power adapter is for indoor use only.
- Be sure the DC plug is securely connected to the camera.
- Turn the camera off before disconnecting the adapter. Disconnect the adapter by the plug, not the cable.
- Do not use with other devices.
- Do not disassemble.
- Do not expose to high heat and humidity.
- Do not subject to strong physical shocks.
- The adapter may hum or become hot to the touch during use. This is normal.
- If the adapter causes radio interference, reorient or relocate the receiving antenna.

Using the Camera

- Do not aim the camera at extremely bright light sources, such as the sun in a cloudless sky. Failure to observe this precaution could damage the camera image sensor.
- Strong sunlight focused through the viewfinder may damage the panel of electronic viewfinder (EVF). Do not aim the electronic viewfinder at the sun.

Take Test Shots

Before taking photographs on important occasions (such as at weddings or before taking the camera on a trip), take a test shot and view the results to ensure that the camera is functioning normally. FUJIFILM Corporation cannot accept liability for damages or lost profits incurred as a result of product malfunction.

Notes on Copyright

Unless intended solely for personal use, images recorded using your digital camera system cannot be used in ways that infringe copyright laws without the consent of the owner. Note that some restrictions apply to the photographing of stage performances, entertainments, and exhibits, even when intended purely for personal use. Users are also asked to note that the transfer of memory cards containing images or data protected under copyright laws is only permissible within the restrictions imposed by those copyright laws.

Handling

To ensure that images are recorded correctly, do not subject the camera to impact or physical shocks while images are being recorded.

Liquid Crystal

In the event that the display is damaged, care should be taken to avoid contact with liquid crystal. Take the urgent action indicated should any of the following situations arise:

- **If liquid crystal comes in contact with your skin**, clean the area with a cloth and then wash thoroughly with soap and running water.
- **If liquid crystal enters your eyes**, flush the affected eye with clean water for at least 15 minutes and then seek medical assistance.
- **If liquid crystal is swallowed**, rinse your mouth thoroughly with water. Drink large quantities of water and induce vomiting, then seek medical assistance.

Although the display is manufactured using extremely high-precision technology, it may contain pixels that are always lit or that do not light. This is not a malfunction, and images recorded with the product are unaffected.

Trademark Information

The typefaces included herein are solely developed by Dyna-Comware Taiwan Inc. Mac, OS X, and macOS are trademarks of Apple Inc. in the U.S.A. and other countries. Windows is a registered trademark of Microsoft Corporation in the U.S.A. and other countries. Wi-Fi® and Wi-Fi Protected Setup® are registered trademarks of the Wi-Fi Alliance. The Bluetooth® word mark and logos are registered trademarks owned by the Bluetooth SIG, Inc., and any use of such marks by Fujifilm is under license. The SDHC and SDXC logos are trademarks of SD-3C, LLC. The HDMI logo is a trademark or registered trademark of HDMI Licensing LLC. All other trade names mentioned in this manual are the trademarks or registered trademarks of their respective owners.

Electrical Interference

This camera may interfere with hospital or aviation equipment. Consult with hospital or airline staff before using the camera in a hospital or on an aircraft.

Color Television Systems

NTSC (National Television System Committee) is a color television telecasting specification adopted mainly in the U.S.A., Canada, and Japan. PAL (Phase Alternation by Line) is a color television system adopted mainly in European countries and China.

Exif Print (Exif Version 2.3)

Exif Print is a newly revised digital camera file format in which information stored with photographs is used for optimal color reproduction during printing.

IMPORTANT NOTICE: Read Before Using the Software

Direct or indirect export, in whole or in part, of licensed software without the permission of the applicable governing bodies is prohibited.

NOTICES

To prevent fire or shock hazard, do not expose the unit to rain or moisture.

Please read the "Safety Notes" and make sure you understand them before using the camera.

Perchlorate Material—special handling may apply. See:

<http://www.dtsc.ca.gov/hazardouswaste/perchlorate>

For Customers in the U.S.A.

Tested To Comply With FCC Standards FOR HOME OR OFFICE USE



Contains IC : 7736B-02100005

Contains FCC ID : W22-02100005

FCC Statement: This device complies with Part 15 of the FCC Rules. Operation is subject to the following two conditions:

- (1) This device may not cause harmful interference, and
- (2) this device must accept any interference received, including interference that may cause undesired operation.

CAUTION: This equipment has been tested and found to comply with the limits for a Class B digital device, pursuant to Part 15 of the FCC Rules. These limits are designed to provide reasonable protection against harmful interference in a residential installation. This equipment generates, uses, and can radiate radio frequency energy and, if not installed and used in accordance with the instructions, may cause harmful interference to radio communications. However, there is no guarantee that interference will not occur in a particular installation. If this equipment does cause harmful interference to radio or television reception, which can be determined by turning the equipment off and on, the user is encouraged to try to correct the interference by one or more of the following measures:

- Reorient or relocate the receiving antenna.
- Increase the separation between the equipment and receiver.
- Connect the equipment into an outlet on a circuit different from that to which the receiver is connected.
- Consult the dealer or an experienced radio/TV technician for help.

FCC Caution: Any changes or modifications not expressly approved by the party responsible for compliance could void the user's authority to operate this equipment.

This transmitter must not be co-located or operating in conjunction with any other antenna or transmitter.

Radiation Exposure Statement: This device meets the government's requirements for exposure to radio waves. This device is designed and manufactured not to exceed the emission limits for exposure to radio frequency (RF) energy set by the Federal Communications Commission of the U.S. Government.

The exposure standard for wireless device employs a unit of measurement known as the Specific Absorption Rate, or SAR. The SAR limit set by the FCC is 1.6W/kg. Tests for SAR are conducted using standard operating positions accepted by the FCC with the device transmitting at its highest certified power level in all tested frequency bands.

Notes on the Grant: To comply with Part 15 of the FCC Rules, this product must be used with a Fujifilm-specified ferrite-core A/V cable, USB cable, and DC supply cord.



A lithium ion battery that is recyclable powers the product you have purchased. Please call 1-800-8-BATTERY for information on how to recycle this battery.

For Customers in Canada

CAN ICES-3 (B)/NMB-3(B)

CAUTION: This Class B digital apparatus complies with Canadian ICES-003.

Industry Canada statement: This device complies with Industry Canada's licence-exempt RSSs. Operation is subject to the following two conditions: (1) This device may not cause interference; and (2) This device must accept any interference, including interference that may cause undesired operation of the device.

This device and its antenna(s) must not be co-located or operating in conjunction with any other antenna or transmitter, except tested built-in radios. The County Code Selection feature is disabled for products marketed in the US/ Canada.

Radiation Exposure Statement: The available scientific evidence does not show that any health problems are associated with using low power wireless devices. There is no proof, however, that these low power wireless devices are absolutely safe. Low power Wireless devices emit low levels of radio frequency energy (RF) in the microwave range while being used. Whereas high levels of RF can produce health effects (by heating tissue), exposure of low-level RF that does not produce heating effects causes no known adverse health effects. Many studies of low-level RF exposures have not found any biological effects. Some studies have suggested that some biological effects might occur, but such findings have not been confirmed by additional research. FinePix XP140 has been tested and found to comply with IC radiation exposure limits set forth for an uncontrolled environment and meets RSS-102 of the IC radio frequency (RF) Exposure rules.

Disposal of Electrical and Electronic Equipment in Private Households

In the European Union, Norway, Iceland and

Liechtenstein: This symbol on the product, or in the manual and in the warranty, and/or on its packaging indicates that this product shall not be treated as household waste. Instead it should be taken to an applicable collection point for the recycling of electrical and electronic equipment.



By ensuring this product is disposed of correctly, you will help prevent potential negative consequences to the environment and human health, which could otherwise be caused by inappropriate waste handling of this product.

This symbol on the batteries or accumulators indicates that those batteries shall not be treated as household waste.



If your equipment contains easy removable batteries or accumulators please dispose these separately according to your local requirements.

The recycling of materials will help to conserve natural resources. For more detailed information about recycling this product, please contact your local city office, your household waste disposal service or the shop where you purchased the product.

In Countries Outside the European Union, Norway, Iceland and

Liechtenstein: If you wish to discard this product, including the batteries or accumulators, please contact your local authorities and ask for the correct way of disposal.

In Japan: This symbol on the batteries indicates that they are to be disposed of separately.



Li-ion

Wireless Network and Bluetooth Devices: Cautions

This product complies with the following EU Directives:

- RoHS Directive 2011/65/EU
- RE Directive 2014/53/EU

Hereby, FUJIFILM Corporation declares that the radio equipment type FinePix XP140 is in compliance with Directive 2014/53/EU.

The full text of the EU declaration of conformity is available at the following internet address: http://www.fujifilm.com/products/digital_cameras/xp/finepix_xp140/pdf/index/finepix_xp140_cod.pdf

This compliance is indicated by the following conformity marking placed on the product:



This marking is valid for non-Telecom products and EU harmonized Telecom products (e.g. Bluetooth®).

IMPORTANT: Read the following notices before using the camera's built-in wireless transmitter.

① This product, which contains encryption function developed in the United States, is controlled by the United States Export Administration Regulations and may not be exported or re-exported to any country to which the United States embargoes goods.

- **Use only a wireless network or Bluetooth device.** Fujifilm does not accept liability for damages resulting from unauthorized use. Do not use in applications requiring a high degree of reliability, for example in medical devices or other systems that may directly or indirectly impact human life. When using the device in computer and other systems that demand a greater degree of reliability than offered by wireless network or Bluetooth devices, be sure to take all necessary precautions to ensure safety and prevent malfunction.
- **Use only in the country in which the device was purchased.** This device conforms to regulations governing wireless network and Bluetooth devices in the country in which it was purchased. Observe all location regulations when using the device. Fujifilm does not accept liability for problems arising from use in other jurisdictions.
- **Do not use the device in locations subject to magnetic fields, static electricity, or radio interference.** Do not use the transmitter in the vicinity of microwave ovens or in other locations subject to magnetic fields, static electricity, or radio interference that may prevent reception of wireless signals. Mutual interference may occur when the transmitter is used in the vicinity of other wireless devices operating in the 2.4 GHz band.

- **The wireless transmitter operates in the 2.4 GHz band using DSSS, OFDM and GFSK modulation.**

- **Security:** Wireless network and Bluetooth devices transmit data via radio and consequently their use requires greater attention to security than applies in the case of wired networks.

- Do not connect to unknown networks or networks to which you do not have access rights, even if they are displayed on your device, as such access may be considered unauthorized. Connect only to networks to which you have access rights.
- Be aware that wireless transmissions may be vulnerable to interception by third parties.

- **The following may be punishable by law:**

- Disassembly or modification of this device
- Removal of device certification labels

- **This device operates on the same frequency as commercial, educational, and medical devices and wireless transmitters.** It also operates on the same frequency as licensed transmitters and special unlicensed low-voltage transmitters used in RFID tracking systems for assembly lines and in other similar applications.

- Do not connect to unknown networks or networks to which you do not have access rights, even if they are displayed on your device, as such access may be considered unauthorized. Connect only to networks to which you have access rights.
- Be aware that wireless transmissions may be vulnerable to interception by third parties.

- **To prevent interference with the above devices, observe the following precautions.** Confirm that the RFID transmitter is not in operation before using this device. Should you observe that the device causes interference in licensed transmitters used for RFID tracking, immediately stop using the affected frequency or move the device to another location. If you notice that this device causes interference in low-voltage RFID tracing systems, contact a Fujifilm representative.

- Do not use this device on board an aircraft. Note that Bluetooth may remain on even when the camera is off. Bluetooth can be disabled by selecting **OFF** for  **CONNECTION SETTING > Bluetooth SETTINGS > Bluetooth ON/OFF.**

- **Do not use this device on board an aircraft.** Note that Bluetooth may remain on even when the camera is off. Bluetooth can be disabled by selecting **OFF** for  **CONNECTION SETTING > Bluetooth SETTINGS > Bluetooth ON/OFF.**

Product Care

To ensure continued enjoyment of the product, observe the following precautions.

Camera body: Use a soft, dry cloth to clean the camera body after each use. Do not use alcohol, thinner, or other volatile chemicals, which could discolor or deform the leather on the camera body. Any liquid on the camera should be removed immediately with a soft, dry cloth. Use a blower to remove dust from the monitor, taking care to avoid scratches, and then gently wipe with a soft, dry cloth. Any remaining stains can be removed by wiping gently with a piece of Fujifilm lens-cleaning paper to which a small amount of lens-cleaning fluid has been applied.

Firmware Updates

Updates to product firmware may result in changes not described in the manual. For more information, visit:
http://www.fujifilm.com/support/digital_cameras/software

Checking the Firmware Version

 The camera will only display the firmware version if a memory card is inserted.

- 1 Turn the camera off and check that a memory card is inserted.
- 2 Turn the camera on while holding the **DISP/BACK** button. The current firmware version will be displayed; check the firmware version.
- 3 Turn the camera off.









Troubleshooting

Consult the table below should you encounter problems using your camera. If you don't find the solution here, contact your local Fujifilm distributor.

Water in the Camera

Problem	Solution
Water in the camera.	The battery-chamber cover was not fully closed before the camera was immersed, or was opened under water: Take the camera to a Fujifilm-authorized service technician for repairs. Do not turn the camera on.

Power and Battery

Problem	Solution
The camera cannot be turned off by pressing the ON/OFF button or pressing and holding the  button.	<ul style="list-style-type: none">• The battery is exhausted: Charge the battery or insert a fully-charged spare battery ( 20).• The battery is inserted incorrectly: Reinsert in the correct orientation ( 15).• The battery-chamber cover is not latched: Latch the battery-chamber cover ( 15).
The battery runs down quickly.	<ul style="list-style-type: none">• The battery is cold: Warm the battery by placing it in a pocket or other warm place and reinsert it in the camera immediately before taking a picture.• There is dirt on the battery terminals: Clean the terminals with a soft, dry cloth.•  TRACKING is selected for FOCUS MODE: Select a different focus mode ( 57).• + is selected for shooting mode: Select a different mode ( 44).• The battery has been charged many times: The battery has reached the end of its charging life. Purchase a new battery.

Problem	Solution
The camera turns off suddenly.	The battery is exhausted: Charge the battery or insert a fully-charged spare battery (📖 20).
Charging does not start.	Reinsert the battery in the correct orientation and make sure that the AC power adapter is plugged in (📖 15, 20).
Charging is slow.	Charge the battery at room temperature.
The self-timer lamp blinks and the battery does not charge.	<ul style="list-style-type: none"> • There is dirt on the battery terminals: Clean the terminals with a soft, dry cloth (📖 15). • The battery has been charged many times: The battery has reached the end of its charging life. Purchase a new battery. If the battery still fails to charge, contact your Fujifilm dealer (📖 118). • The battery is too hot or too cold: Wait for the battery temperature to stabilize (📖 20).

Menus and Displays

Problem	Solution
Display is not in English.	Select ENGLISH for 言語/LANG. (📖 27, 101).

Shooting

Problem	Solution
No picture is taken when the shutter button is pressed.	<ul style="list-style-type: none">• Memory is full: Insert a new memory card or delete pictures (📖 15, 87).• Memory is not formatted: Format the memory card or internal memory (📖 111).• There is dirt on the memory card contacts: Clean the contacts with a soft, dry cloth.• The memory card is damaged: Insert a new memory card (📖 15).• The battery is exhausted: Charge the battery or insert a fully-charged spare battery (📖 20).• The camera has turned off automatically: Turn the camera on (📖 23).
Mottling (“noise”) appears in the monitor when the shutter button is pressed halfway.	Gain is increased to aid composition when the subject is poorly lit, which may result in noticeable mottling when images are previewed in the displays. Images taken with the camera are unaffected.
The camera does not focus.	The subject is not suited to autofocus: Use focus lock (📖 58).
No face is detected.	<ul style="list-style-type: none">• The subject’s face is obscured by sunglasses, a hat, long hair, or other objects: Remove the obstructions (📖 66).• The subject’s face occupies only a small area of the frame: Change the composition so that the subject’s face occupies a larger area of the frame (📖 66).• The subject’s head is tilted or horizontal: Ask the subject to hold their head straight (📖 66).• The camera is tilted: Keep the camera level.• The subject’s face is poorly lit: Shoot in bright light.
Wrong subject is selected.	The selected subject is closer to the center of the frame than the main subject. Recompose the picture or turn face detection off and frame the picture using focus lock (📖 58).

Problem	Solution
Movie recording and 4K burst are unavailable.	The memory card write speed is too slow: Use a memory card with a UHS speed class of 3 or better (📖 18, 36, 54).
The flash does not fire.	<ul style="list-style-type: none"> • The flash is disabled: Adjust settings (📖 59). • The battery is exhausted: Charge the battery or insert a fully-charged spare battery (📖 20). • The camera is in continuous mode: Select single frame mode (📖 53). • OFF is selected for SOUND & FLASH: Select ON (📖 101).
Some flash modes are not available.	OFF is selected for SOUND & FLASH: Select ON (📖 101).
The flash does not fully light the subject.	<ul style="list-style-type: none"> • The subject is not in range of the flash: Position the subject in range of the flash. • The flash window is obstructed: Hold the camera correctly.
Pictures are blurred.	<ul style="list-style-type: none"> • The protective glass covering the lens is dirty: Clean the glass. • The protective glass covering the lens is blocked: Keep objects away from the lens (📖 30). • !AF is displayed during shooting and the focus frame is displayed in red: Check focus before shooting (📖 31). • !📷 is displayed during shooting: Use the flash or a tripod (📖 59).
Pictures are mottled.	<ul style="list-style-type: none"> • Shutter speed is slow and the ambient temperature is high: This is normal and does not indicate a malfunction. • The camera has been used continuously at high temperatures or a temperature warning is displayed: Turn the camera off and wait for it to cool down (📖 23, 154).
Location data	Location data are incorrect. The camera has been moved since location data were last updated.

Playback





Problem	Solution
Pictures are grainy.	The pictures were taken with a different make or model of camera.
Playback zoom is unavailable.	The pictures were created using RESIZE or with a different make or model of camera.
No sound in movie playback.	<ul style="list-style-type: none">• Playback volume is too low: Adjust playback volume (📖 102).• The microphone was obstructed: Hold the camera correctly during recording.• The speaker is obstructed: Hold the camera correctly during playback.• OFF is selected for SOUND & FLASH: Select ON (📖 101).
Selected pictures are not deleted.	Some of the pictures selected for deletion are protected. Remove protection using the device with which it was originally applied (📖 92).
File numbering is unexpectedly reset.	The battery-chamber cover was opened while the camera was on. Turn the camera off before opening the battery-chamber cover (📖 106).

Connections

Problem	Solution
The monitor is blank.	<p>The camera is connected to a TV: Pictures will be displayed on the TV instead of in the camera monitor (📖 120).</p>
No picture or sound on TV.	<ul style="list-style-type: none"> • The camera is not properly connected: Connect the camera properly (📖 120). • Input on the television is set to “TV”: Set input to “HDMI” (📖 120). • The volume on the TV is too low: Use the controls on the television to adjust the volume (📖 120).
The computer does not recognize the camera.	<p>Be sure the camera and computer are correctly connected (📖 125).</p>
Cannot transfer pictures to computer.	<p>Use MyFinePix Studio to transfer pictures (Windows only; 📖 125).</p>

Wireless Transfer

For additional information on troubleshooting wireless connections, visit: <http://digital-cameras.support.fujifilm.com/app?pid=x>



Problem	Solution
Smartphone will not display pictures.	Select ON for RESIZE IMAGE FOR SMARTPHONE  3M. Selecting OFF increases upload times for larger images; in addition, some phones may not display images over a certain size ( 110).
Cannot connect to smartphone. The camera is slow to connect or upload pictures to the smartphone. Upload fails or is interrupted.	<ul style="list-style-type: none">• The smartphone is too far away: Move the devices closer ( 122).• Nearby devices are causing radio interference: Move the camera and smartphone away from microwave ovens or cordless phones ( 122).• The smartphone is connected to another device: The smartphone and camera can connect to only one device at a time. End the connection and try again.
Cannot upload images.	<ul style="list-style-type: none">• There are several smartphones in the vicinity: Try connecting again. The presence of multiple smartphones can make connection difficult.• The image is a movie: Uploading movies takes some time. Movies intended for display on a smartphone or tablet should be recorded at a frame size of 1280×720 (HD) or smaller. For information on viewing the pictures on the camera, visit: http://app.fujifilm-dsc.com/en/camera_remote/• The image was created on another device: The camera may not be able to upload images created on other devices.

Miscellaneous













Problem	Solution
The camera is unresponsive.	<ul style="list-style-type: none"> • Temporary camera malfunction: Remove and reinsert the battery (📖 15). • The battery is exhausted: Charge the battery or insert a fully-charged spare battery (📖 20). • The camera is connected to a wireless LAN: End the connection.
The camera does not function as expected.	Remove and reinsert the battery (📖 15). If the problem persists, contact your Fujifilm dealer.
No sound.	<ul style="list-style-type: none"> • Adjust the volume (📖 102). • Select ON for SOUND & FLASH (📖 101).
Time and date stamps.	<ul style="list-style-type: none"> • Time and date stamps are not correct: Set the camera clock (📖 27, 100). • Time and date stamps appear on photographs: Time and date stamps cannot be deleted. To prevent stamps appearing on new photographs, select OFF for SAVE DATA SET-UP > DATE STAMP (📖 107).

Warning Messages and Displays

The following warnings appear in the display.







Warning	Description
 (red)	Low battery. Charge the battery or insert a fully-charged spare battery.
 (blinks red)	Battery exhausted. Charge the battery or insert a fully-charged spare battery.
	Slow shutter speed. Pictures may be blurred; use the flash or a tripod.
!AF (displayed in red with red focus frame)	The camera cannot focus. Use focus lock to focus on another subject at the same distance, then recompose the picture.
Aperture or shutter speed displayed in red	The subject is too bright or too dark and the picture will be over- or under-exposed. Use the flash for additional lighting when taking photographs of poorly-lit subject.
FOCUS ERROR	Camera malfunction. Turn the camera off and then on again. If the message persists, contact a Fujifilm dealer.
LENS CONTROL ERROR	
TURN OFF THE CAMERA AND TURN ON AGAIN	
NO CARD	No memory card inserted when COPY is selected in the playback menu. Insert a memory card.
CARD NOT INITIALIZED	<ul style="list-style-type: none">• The memory card or internal memory is not formatted or the memory card was formatted in a computer or other device: Format the memory card or internal memory using the FORMAT option in the camera setup menu.• The memory card contacts require cleaning: Clean the contacts with a soft, dry cloth. If the message is repeated, format the card. If the message persists, replace the card.• Camera malfunction: Contact a Fujifilm dealer.

Warning	Description
CARD ERROR	<ul style="list-style-type: none"> • The memory card is not formatted for use in the camera: Format the card. • The memory card contacts require cleaning or the memory card is damaged: Clean the contacts with a soft, dry cloth. If the message is repeated, format the card. If the message persists, replace the card. • Incompatible memory card: Use a compatible card. • Camera malfunction: Contact a Fujifilm dealer.
PROTECTED CARD	The memory card is locked. Unlock the card.
BUSY	The memory card is incorrectly formatted. Use the camera to format the card.
SD MEMORY FULL INTERNAL MEMORY IS FULL INSERT A NEW CARD	The memory card or internal memory is full and pictures cannot be recorded or copied. Delete pictures or insert a memory card with more free space.
WRITE ERROR	<ul style="list-style-type: none"> • Memory card error or connection error: Reinsert the card or turn the camera off and then on again. If the message persists, contact a Fujifilm dealer. • Not enough memory remaining to record additional pictures: Delete pictures or insert a memory card with more free space. • The memory card or internal memory is not formatted: Format the memory card or internal memory.
TOO MANY FRAMES	A search has returned more than 5,000 results, or more than 999 frames were selected for deletion. Perform a different search or select fewer pictures.
FRAME NO. FULL	The camera has run out of frame numbers (current frame number is 999-9999). Format the memory card and select RENEW for FRAME NO. . Take a picture to reset frame numbering to 100-0001, then select CONTINUOUS for FRAME NO. .

Warning	Description
READ ERROR	<ul style="list-style-type: none"> • The file is corrupt or was not created with the camera: The file cannot be viewed. • The memory card contacts require cleaning: Clean the contacts with a soft, dry cloth. If the message is repeated, format the card. If the message persists, replace the card. • Camera malfunction: Contact a Fujifilm dealer.
PROTECTED FRAME	An attempt was made to delete or rotate to a protected picture. Remove protection and try again.
 NO IMAGE	The source selected for COPY contains no images. Select a different source.
 NO IMAGE	
 CAN NOT CROP	 pictures cannot be cropped.
CAN NOT CROP	The picture is damaged or was not created with the camera.
DPOF FILE ERROR	Print orders can contain no more than 999 pictures. Copy any additional pictures you wish to print to another memory card and create a second print order.
 CANNOT EXECUTE	An attempt was made to create a resized copy at a size equal to or larger than the original. Choose a smaller size.
 CANNOT EXECUTE	
 CANNOT EXECUTE	
CAN NOT SET DPOF	The picture cannot be printed using DPOF.
 CAN NOT SET DPOF	Movies cannot be printed using DPOF.
CAN NOT ROTATE	The selected picture cannot be rotated.
 CAN NOT ROTATE	Movies cannot be rotated.
 CANNOT EXECUTE	Red-eye removal cannot be applied to movies.
 CANNOT EXECUTE	Red-eye removal cannot be applied to pictures created with other devices.
COMMUNICATION ERROR	A connection error occurred while pictures were being printed or copied to a computer or other device. Confirm that the device is turned on and that the USB cable is connected.
Ensure the battery chamber cover is locked.	Check that the battery-chamber cover is latched. Note that the cover may already be latched; this message merely encourages you to check that the cover is secure before proceeding.
	Turn the camera off and wait for it to cool. Mottling may increase in pictures taken when this warning is displayed.

Memory Card Capacity

The following table shows the recording time or number of pictures available at different image sizes. All figures are approximate; file size varies with the scene recorded, producing wide variations in the number of files that can be stored. The number of exposures or length remaining may not diminish at an even rate.

		Capacity	8 GB		16 GB	
			FINE	NORMAL	FINE	NORMAL
Photos	 4:3		1000	1590	2000	3190
	 2160/15P		13 minutes		26 minutes	
Movies ^{1,2}	 1080/59.94P, 50P, 24P, 23.98P		27 minutes		55 minutes	
	 1080 SQUARE 59.94P, 50P, 24P, 23.98P		47 minutes		95 minutes	
	 720/59.94P, 50P, 24P, 23.98P		52 minutes		105 minutes	
	 720 SQUARE 59.94P, 50P, 24P, 23.98P		89 minutes		178 minutes	

1 Use a UHS speed class 3 card or better.

2 Individual movies cannot exceed 29 minutes in length or 4 GB in size.

Temperature Warnings

The camera automatically turns off to protect itself when its temperature or the temperature of the battery rises. If a temperature warning is displayed, image noise may increase. Turn the camera off and wait for it to cool before turning it on again ( 154).

Specifications

System																			
Model	Digital Camera FinePix XP140 Series																		
Effective pixels	Approx. 16.35 million																		
Image sensor	½ ₃ -in. square pixel CMOS with primary color filter																		
Storage media	<ul style="list-style-type: none"> Internal memory (approx. 90 MB) Fujifilm-recommended SD/SDHC/SDXC memory cards 																		
File system	Compliant with Design Rule for Camera File System (DCF), Exif 2.3, and Digital Print Order Format (DPOF)																		
File format	<ul style="list-style-type: none"> Still pictures: Exif 2.3 JPEG (compressed) Movies: MOV (H.264)/Linear PCM (pseudo-stereo) 																		
Image size	<table border="0"> <tbody> <tr> <td>L 4:3 (4608 × 3456)</td> <td>L 3:2 (4608 × 3072)</td> </tr> <tr> <td>M 4:3 (3264 × 2448)</td> <td>M 3:2 (3264 × 2176)</td> </tr> <tr> <td>S 4:3 (2048 × 1536)</td> <td>S 3:2 (2304 × 1536)</td> </tr> <tr> <td>L 16:9 (4608 × 2592)</td> <td>L 1:1 (3456 × 3456)</td> </tr> <tr> <td>M 16:9 (3264 × 1840)</td> <td>M 1:1 (2432 × 2432)</td> </tr> <tr> <td>S 16:9 (1920 × 1080)</td> <td>S 1:1 (1728 × 1728)</td> </tr> <tr> <td colspan="2">CALS CALS (1280 × 960)</td> </tr> <tr> <td colspan="2">L panorama: vertical (5760 × 1632)/horizontal (5760 × 1088)</td> </tr> <tr> <td colspan="2">M panorama: vertical (3840 × 1632)/horizontal (3840 × 1088)</td> </tr> </tbody> </table>	L 4:3 (4608 × 3456)	L 3:2 (4608 × 3072)	M 4:3 (3264 × 2448)	M 3:2 (3264 × 2176)	S 4:3 (2048 × 1536)	S 3:2 (2304 × 1536)	L 16:9 (4608 × 2592)	L 1:1 (3456 × 3456)	M 16:9 (3264 × 1840)	M 1:1 (2432 × 2432)	S 16:9 (1920 × 1080)	S 1:1 (1728 × 1728)	CALS CALS (1280 × 960)		L panorama: vertical (5760 × 1632)/horizontal (5760 × 1088)		M panorama: vertical (3840 × 1632)/horizontal (3840 × 1088)	
L 4:3 (4608 × 3456)	L 3:2 (4608 × 3072)																		
M 4:3 (3264 × 2448)	M 3:2 (3264 × 2176)																		
S 4:3 (2048 × 1536)	S 3:2 (2304 × 1536)																		
L 16:9 (4608 × 2592)	L 1:1 (3456 × 3456)																		
M 16:9 (3264 × 1840)	M 1:1 (2432 × 2432)																		
S 16:9 (1920 × 1080)	S 1:1 (1728 × 1728)																		
CALS CALS (1280 × 960)																			
L panorama: vertical (5760 × 1632)/horizontal (5760 × 1088)																			
M panorama: vertical (3840 × 1632)/horizontal (3840 × 1088)																			
Lens	<ul style="list-style-type: none"> Type: Fujinon 5× optical zoom lens Focal length: f=5.0 mm–25.0 mm (35-mm format: approximately equivalent to 28 mm–140 mm) Maximum aperture: F3.9 (wide angle) – F4.9 (telephoto) 																		
Digital zoom	Up to about 2× with intelligent digital zoom (up to 10× when combined with optical zoom)																		
Aperture	F3.9/F6.2 (wide angle), F4.9/F8.0 (telephoto)																		
Focus range (distance from front of lens)	Approx. 9 cm (0.2 ft.)–infinity (wide angle); 1.0 m (3.2 ft.)–infinity (telephoto)																		
Sensitivity	Standard output sensitivity equivalent to ISO 100–12800 in increments of 1 EV; AUTO *, AUTO (1600), AUTO (800), AUTO (400) * AUTO is only displayed if AUTO (1600) , AUTO (800) , and AUTO (400) are unavailable.																		

System

Movies

- Movies with pseudo-stereo sound

4K 2160/15P

FULL HD 1080/59.94P

FULL HD 1080/50P

FULL HD 1080/24P

FULL HD 1080/23.98P

SFHD 1080 SQUARE 59.94P

SFHD 1080 SQUARE 50P

SFHD 1080 SQUARE 24P

SFHD 1080 SQUARE 23.98P

HD 720/59.94P

HD 720/50P

HD 720/24P

HD 720/23.98P



SFHD 720 SQUARE 59.94P

SFHD 720 SQUARE 50P



SFHD 720 SQUARE 24P



SFHD 720 SQUARE 23.98P

- Silent HD high-speed movies

1.6×  59.94P  100P

2×  50P  100P

3.3×  29.97P  100P

4×  25P  100P

Input/output terminals

Digital input/output USB 2.0 High-Speed, Micro USB connector (Micro-B);
MTP/PTP



HDMI output HDMI Micro connector (Type D)

Power supply/other

Power supply	NP-45S rechargeable battery (supplied with camera)
Camera size (W × H × D)	109.6 mm × 71.0 mm × 27.8 mm/4.3 in. × 2.7 in. × 1.0 in., excluding projections
Camera weight	Approx. 190.6 g/6.7 oz., excluding battery, accessories, and memory card
Shooting weight	Approx. 207.4 g/7.3 oz., including battery and memory card
Operating conditions	<ul style="list-style-type: none"> • Temperature: –10 °C to +40 °C/+14 °F to +104 °F • Humidity: 10% to 80% (no condensation)
Battery life	<ul style="list-style-type: none"> • Battery type: NP-45S • Shooting mode: mode P

Approximate number of frames

240

Mode	Actual battery life of movie capture	Continuance battery life of movie capture
	Approx. 42 minutes	Approx. 73 minutes
 *	Approx. 40 minutes	Approx. 54 minutes

* At a frame rate of 59.94 fps.

CIPA standard, measured using battery supplied with camera and SD memory card.

Note: Number of shots that can be taken with battery varies with battery charge level and will decline at low temperatures.

Wireless transmitter

Wireless LAN

Standards	IEEE 802.11b/g/n (standard wireless protocol)
Operating frequency (center frequency)	<ul style="list-style-type: none">• Japan, China: 2,412 MHz–2,472 MHz (13 channels)• Other countries: 2,412 MHz–2,462 MHz (11 channels)
Maximum radio-frequency power (EIRP)	5.67 dBm
Access protocols	Infrastructure

Bluetooth®

Standards	Bluetooth version 4.1 (Bluetooth Low Energy)
Operating frequency (center frequency)	2,402 MHz–2,480 MHz
Maximum radio-frequency power (EIRP)	2.69 dBm

NP-45S rechargeable battery**Nominal voltage** 3.7 V DC**Nominal capacity** 740 mAh**Operating temperature** 0 °C to +40 °C/+32 °F to +104 °F**Dimensions** 31.4 mm × 39.5 mm × 5.8 mm/1.2 in. × 1.5 in. × 0.2 in.
(W × H × D)**Weight** Approx. 19 g/0.6 oz.**AC-5VG AC power adapter****Rated input** 100 V – 240 V AC, 50/60 Hz**Input capacity** 10.5 VA (100 V), 11.9 VA (240 V)**Rated output** 5.0 V DC, 1000 mA**Operating temperature** 0 °C to +40 °C/+32 °F to +104 °F**Weight** Approx. 26 g ± 15%/0.9 oz. ± 15% (AC power adapter only)

Weight and dimensions vary with the country or region of sale.



Specifications and performance are subject to change without notice. Fujifilm will not be held liable for any errors this manual may contain. The appearance of the product may differ from that described in this manual.

FUJIFILM

FUJIFILM Corporation

7-3, AKASAKA 9-CHOME, MINATO-KU, TOKYO 107-0052, JAPAN

http://www.fujifilm.com/products/digital_cameras/index.html

