

BASIC ELECTRICITY

PRICE \$5.00



HEATHKIT

EDUCATIONAL
SERIES

MODEL EK-1

595-253

HEATH COMPANY BENTON HARBOR, MICHIGAN

TYPICAL COMPONENT TYPES

This chart is a guide to commonly used types of electronic components. The symbols and related illustrations

should prove helpful in identifying most parts and reading the schematic diagrams.

<p>RESISTOR</p>	<p>CAPACITOR</p>	<p>TUBE</p>
<p>POTENTIOMETER (CONTROL)</p>	<p>ELECTROLYTIC CAPACITOR</p>	<p>TRANSISTOR</p>
<p>TRANSFORMER (IRON CORE)</p>	<p>VARIABLE CAPACITOR</p>	<p>RECTIFIER (DIODE)</p>
<p>TRANSFORMER (ADJUSTABLE POWDERED IRON CORE) ARROW INDICATES DIRECTION OF CORE MOVEMENT TO INCREASE INDUCTANCE</p>	<p>BATTERY</p>	<p>NEON BULB</p>
<p>TRANSFORMER (ADJUSTABLE CORE)</p>	<p>PHONO JACK</p>	<p>ILLUMINATING BULB</p>
<p>POWER TRANSFORMER</p>	<p>PHONE JACK</p>	<p>METER</p>
<p>INDUCTOR (COIL)</p>	<p>RECEPTACLE</p>	<p>SPST SWITCH (TOGGLE) DPDT</p>
<p>PIEZOELECTRIC CRYSTAL</p>	<p>SPEAKER</p>	<p>SWITCH (ROTARY)</p>
<p>BINDING POST</p>	<p>MICROPHONE</p>	<p>FUSE</p>
<p>ANTENNA GENERAL LOOP</p>	<p>EARTH GROUND CHASSIS GROUND</p>	<p>CONDUCTORS NOT CONNECTED CONNECTED SHIELDED</p>

BASIC ELECTRICITY

★ ★

One of a series of Learn-by-Doing
EDUCATIONAL KITS
prepared especially for
Individual Home Study
or
Group Classroom Instruction

★ ★

HEATH COMPANY
Benton Harbor, Michigan

Copyright © 1959
Heath Company
All rights reserved

THIS BOOK, OR ANY PARTS THEREOF,
MAY NOT BE REPRODUCED IN ANY
FORM WITHOUT WRITTEN PERMISSION
FROM THE HEATH COMPANY

PRINTED IN THE UNITED STATES

OF AMERICA

December 1959

INTRODUCTION

This EK-1 Kit and Manual has been especially prepared to provide you with useful training material in the field of electricity and electronics.

While your use of this and other Heath Educational Kits may start out merely as an interesting hobby, continued interest in this type of activity may help you decide upon your life's work, or may add a new and valuable facet to your intellectual personality.

Every effort has been made to present this material in an easy-to-understand form. Scientific material is of such a nature, however, that you should not hesitate to reread a word, a sentence, or even a paragraph until the meaning reveals itself to you. The dictionary should be most useful. Take time to look up the scientific meaning of any unfamiliar words used in the text.

Above all, take your time in performing the experiments so that you understand what is being demonstrated and why it is important. Rushing through the kit will only detract from the learning experience it can provide.

At the end of each chapter are two sets of questions. The second set, with answers, has been inserted upside down so a person opposite you can check your verbal answers. This is your measuring stick. Use it, and you will be rewarded by the satisfaction of genuine accomplishment.

TABLE OF CONTENTS

	Page
Parts List and Description.....	VI
Recommended Tools.....	VII
Soldering Instructions.....	VII
CHAPTER 1	
Electricity and Series and Parallel Circuits	1
CHAPTER 2	
The Direct Current Milliammeter.....	21
CHAPTER 3	
The Direct Current Voltmeter and Ohmmeter.....	59
CHAPTER 4	
Verifying Ohm's Law and the D-C Maximum Power Transfer Theorem.....	89
CHAPTER 5	
Checking Electrical Appliances and Automobile Circuits.....	101
APPENDIX.....	111
SPECIFICATIONS.....	117
INDEX.....	119

PARTS LIST

PART No.	PARTS Per Kit	DESCRIPTION
----------	---------------	-------------

Resistors

1-3	1	100 ohm 1/2 watt (brown-black-brown)
1-9	1	1,000 ohm 1/2 watt (brown-black-red)
1-33	1	470 K ohm 1/2 watt (yellow-violet-yellow)
2-7	1	9 K ohm 1/2 watt (precision)
2-11	1	100 K ohm 1/2 watt (precision)
2-64	1	110 ohm 1/2 watt (precision)
2-99	1	50 K ohm 1/2 watt (precision)
2-113	1	4 K ohm 1/2 watt (precision)
2-128	1	20 ohm 1/2 watt (precision)
2-131	1	10 ohm 1/2 watt (precision)
2-140	1	250 ohm 1/2 watt (precision)
2-141	1	166 ohm 1/2 watt (precision)
2A-2	1	2 ohm 1 watt (precision)
2A-45	1	500 K ohm 1 watt (precision)

Controls - Switches

10-99	1	250 ohm linear control
10-100	1	1000 ohm linear control
A60-16	1	3 pole DT slide switch
D63-198	1	Rotary switch
D63-199	1	Rotary switch
64-7	1	Push button SPST switch
65-2	1	Knife type SPST switch

Hardware

250-83	2	#10 x 1/2" handle screw
250-89	14	6-32 x 3/8" BH machine screw
252-3	10	6-32 nut
252-7	4	Control nut
252-9	6	Speednut, jack
252-22	2	6-32 folded speednut, Tinnerman
252-32	1	Speednut (small) for pilot lamp
253-2	16	#6 fiber shoulder washer
253-10	4	Control nickel washer
254-1	2	Lockwasher
254-4	4	Control lockwasher
258-7	4	Spring
259-1	10	#6 solder lug
260-1	3	Alligator clip
260-16	16	Alligator clip (small)

Miscellaneous

70-5	2	Banana plug insulator, black
70-6	2	Banana plug insulator, red
A73-20	1	Insulator for alligator test clip (red)
A73-21	2	Insulator for alligator test clip (black)
90-144	1	Cabinet
203-172F-257	1	Front panel
204-M320	1	Battery mounting bracket
204-M254	4	Battery holder bracket
211-4	1	Handle
214-2	4	Battery housing cup
261-4	8	Rubber foot

 1/2 WATT RESISTOR

 1/2 WATT PRECISION RESISTOR

 1 WATT PRECISION RESISTOR

 ROTARY SWITCH

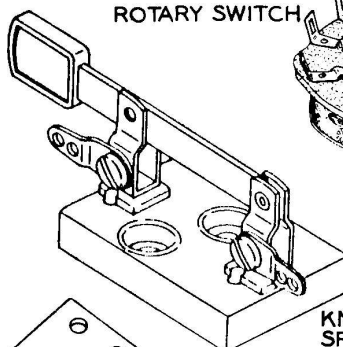
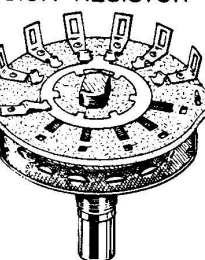

KNIFE TYPE SPST SWITCH

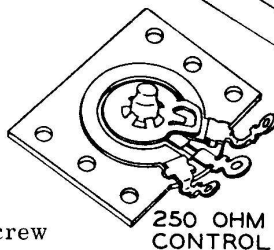

250 OHM CONTROL



1000 OHM CONTROL

 6-32 NUT  LOCKWASHER  6-32X3/8" BHMS

 CONTROL LOCKWASHER

 CONTROL NUT

 CONTROL NICKEL WASHER

 #6 SOLDER LUG

 JACK SPEEDNUT

 #6 FIBER SHOULDER WASHER

 6-32 FOLDED SPEEDNUT

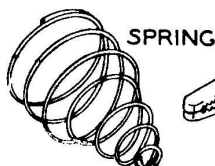
 SPRING

 ALLIGATOR CLIP

 BANANA PLUG INSULATOR

 ALLIGATOR CLIP INSULATOR

PART No.	PARTS Per Kit	DESCRIPTION
----------	---------------	-------------

Miscellaneous (cont'd.)

340-1	1	Length bare wire
341-1	1	Length black test lead
341-2	1	Length red test lead
344-59	1	Length hookup wire
346-1	1	Length insulated sleeving
406-4	1	Compass (toy)
407-63	1	0-1 MA DC meter, 1000 Ω resistance
412-1	2	#47 light bulb
412-12	1	Neon plastic covered bulb
434-21	2	Pilot light socket
436-2	2	Banana jack, black
436-3	4	Banana jack, red
437-1	6	Banana jack insert
438-13	4	Banana plug assembly
439-1	1	Red test prod
462-13	2	Black knob
462-24	2	Pointer knob
331-6		Solder
595-253	1	Manual



BANANA JACK

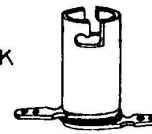

PILOT LIGHT SOCKET



BANANA JACK INSERT

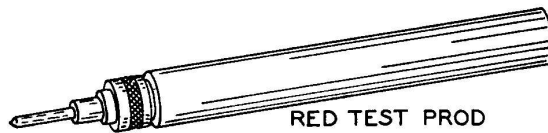

RED TEST PROD

NOTE: Four standard size "C" flashlight batteries should be purchased at this time to be available when needed.

RECOMMENDED TOOLS

SOLDERING IRON

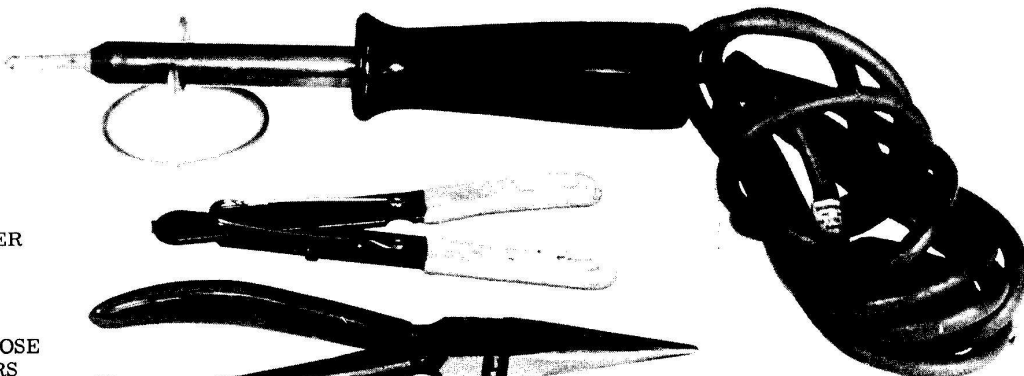

WIRE STRIPPER

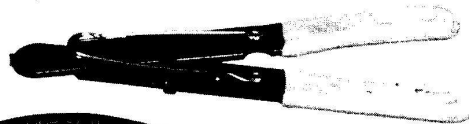

LONG-NOSE PLIERS

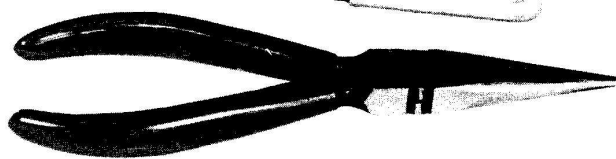

1/8" SCREWDRIVER



3/16" SCREWDRIVER

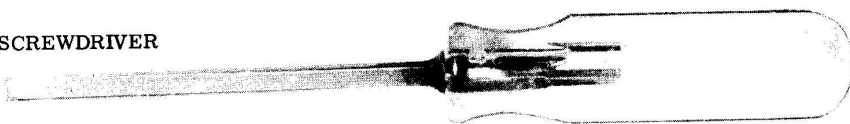

SOLDERING INSTRUCTIONS

You must master the technique of soldering to receive good results from any electrical circuit. These instructions, and practice with various pieces of wire, should enable you to make neat, firm solder joints to assure proper electrical contact.

ROSIN CORE SOLDER HAS BEEN SUPPLIED WITH THIS KIT. THIS TYPE OF SOLDER MUST BE USED FOR ALL SOLDERING IN THIS KIT. ALL GUARANTEES ARE VOIDED AND WE WILL NOT REPAIR OR SERVICE EQUIPMENT IN WHICH ACID CORE SOLDER OR PASTE FLUXES HAVE BEEN USED. IF ADDITIONAL SOLDER IS NEEDED, BE SURE TO PURCHASE ROSIN CORE (60:40 or 50:50 TIN-LEAD CONTENT) RADIO TYPE SOLDER.

For most wiring a 25 to 100 watt iron, or the equivalent in a soldering gun, is satisfactory. In order to put a new electric iron into service, the tip of the iron must be "tinned." Scrape the tip clean with a knife blade (unless directed otherwise by the Manufacturer), then plug the iron into a 117 volt outlet. When the copper tip reaches a temperature hot enough to melt a piece of rosin-core solder held against it, rub solder over the entire tip. This is called "tinning the iron."

Keep the iron tip clean and bright. A cloth may be used to wipe the tip quickly during use.

SOLDERING PROCEDURE

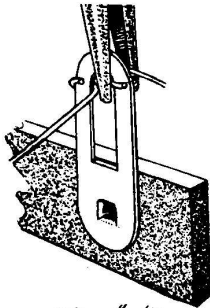

Crimp or bend the lead (or leads) around the terminal to form a good joint without relying on solder for physical strength. If the wire is too large to allow bending, position the wire so that a good solder connection can still be made.

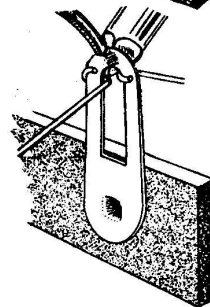

Position the work, if possible, so that gravity will help to keep the solder where you want it.

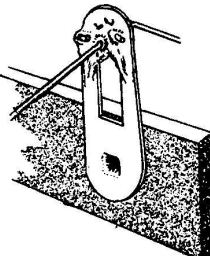

Place a flat side of the soldering iron tip against the joint to be soldered until it is heated sufficiently to melt the solder.

Then place the solder against the heated terminal (not on the iron) and it will immediately flow over the joint. Use only enough solder to thoroughly wet the junction; it is usually not necessary to fill the entire hole in the terminal with solder.

Remove the solder and then the iron from the completed junction. Use care not to move the leads until the solder is solidified.

Now test the soldered joint by moving the wire to see if it is firmly attached and does not move at the joint.

In temporary circuits and hookups, where wires will later be disconnected, follow the above procedure but do not bend or crimp the wires before soldering.

CHAPTER 1

ELECTRICITY AND SERIES AND PARALLEL CIRCUITS

The home of electricity is the atom.

SIMPLE PICTURE OF OXYGEN ATOM

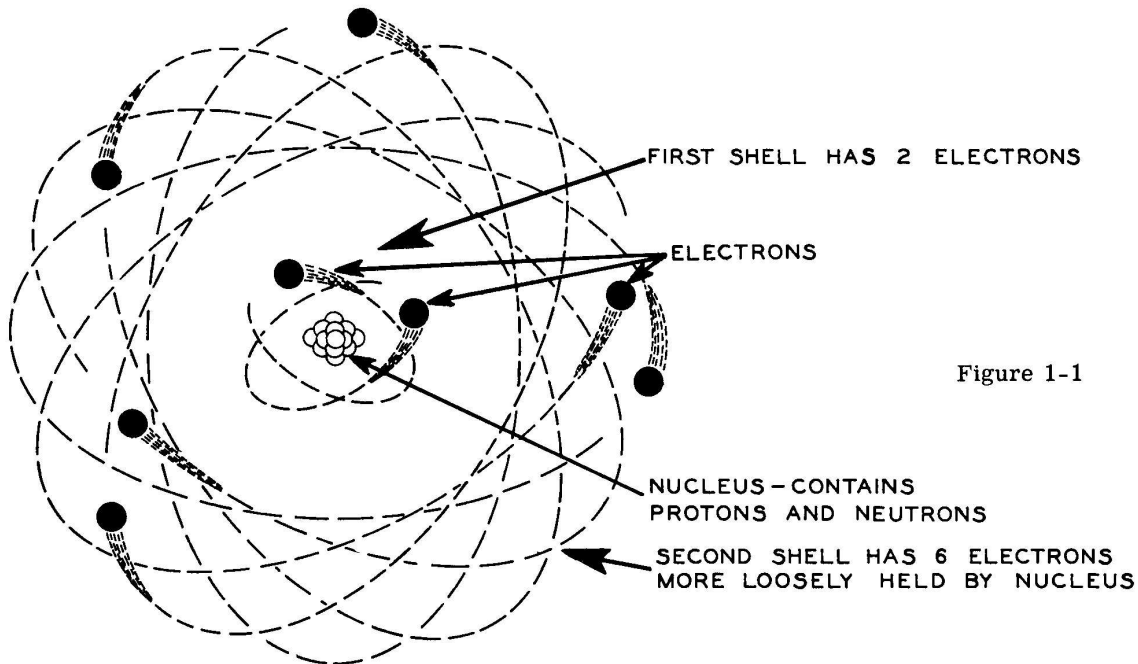

Figure 1-1

The present and widely accepted theory concerning atoms is that they are made up of a nucleus containing one or more protons and neutrons, and one or more electrons whirling around and held captive by the nucleus.

The electrons whirling around the nucleus are held captive by the protons in the nucleus because of "electric forces" similar in action to the force of gravity.

Since this electric force exists, it is reasoned that its existence is due to some property of the proton and electron and this property is referred to as "charge".

The electric force exerted by the proton is equal to, but opposite, that of the electrons. Since the above statement is true, it follows that the charges producing the opposite forces must also be opposite in nature. To designate this opposite nature of charge, a plus (+) sign is assigned to the proton and a negative (-) sign to the electron. The proton is sometimes referred to as positive electricity while the electron is referred to as negative electricity. The neutron does not exert an electrical force on either the proton or electron and, therefore, is said to possess no charge.

The proton and neutron that make up the nucleus of the atom are about 1800 times heavier than the electron.

The above pictured oxygen atom has eight protons and eight neutrons forming the nucleus, and eight electrons whirling around the nucleus in two different shells. The largest atoms have seven shells of electrons. Letters are used to represent the different shells. Starting with the shell closest to the nucleus they are labeled K, L, M, N, O, P, and Q.

To show the atom in its three dimensional form (Figure 1-1) becomes too complicated when an atom of many electrons is to be pictured. A simple flat view showing the different layers of electrons is sufficient. The oxygen atom is pictured in the more simplified form in Figure 1-2.

The 8+ written at the center represents the eight positive protons in the nucleus.

If the atom has not been disturbed in some way, there will always be the same number of electrons as protons. Some atoms have more neutrons than protons in the nucleus.

The oxygen atom, then, is made up of a specific number of electrons, protons and neutrons. Atoms are different from one another chiefly because they contain different numbers of electrons, protons and neutrons. It should be evident that all substances contain positive and negative electricity since all substances are made up of atoms.

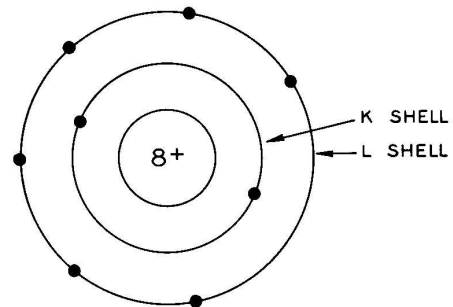

Figure 1-2

When we say that electricity makes the lamp light up, we are really talking about negative electricity or, more specifically, the charge of electrons moving through the lamp. The flashlight cell is a device capable of supplying electrons from the zinc atoms contained in the cell. When the flashlight is turned on, the flashlight cells then deliver electrons to the filament inside the lamp. The electrons cause the thin filament to become hot, thus producing light.

Let us construct electrical circuits by first putting together the four flashlight cell holders, as shown in Figure 1-3, and connecting wires, as shown in Figure 1-4.

Cut two 6" lengths and six 3" lengths of wire from the red test lead wire. Remove about 1/4" of insulation from each end and then solder a small alligator clip to each end.

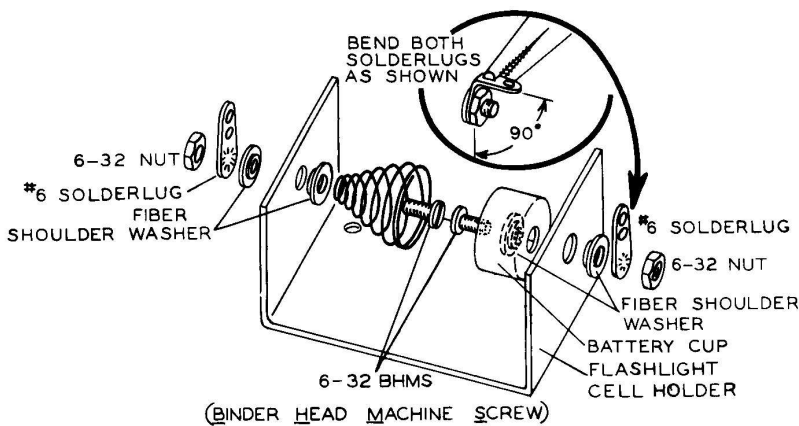

Figure 1-3

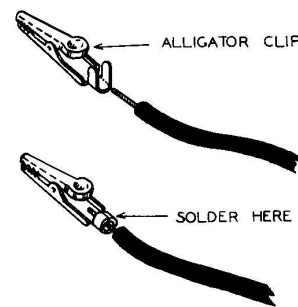

Figure 1-4

Insert the flashlight cells into the cell holders by pulling the spring back and placing the end of the cell with the center raised portion into the cup; then let the spring slide over the other end of the cell. See Figure 1-5A, B and C. CAUTION: Do not allow the head of the cell to touch any metal surface that might short the center post (+) to the jacket (-), as this would immediately exhaust the cell's energy.

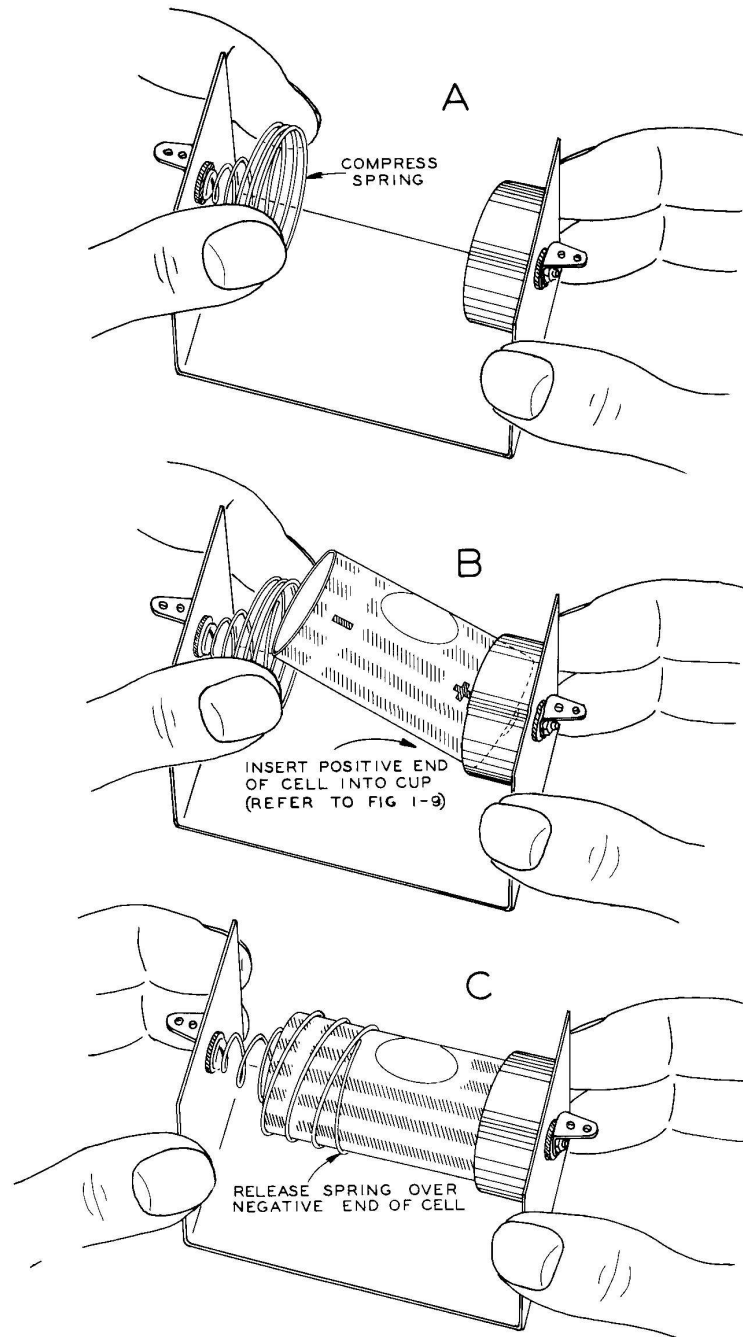
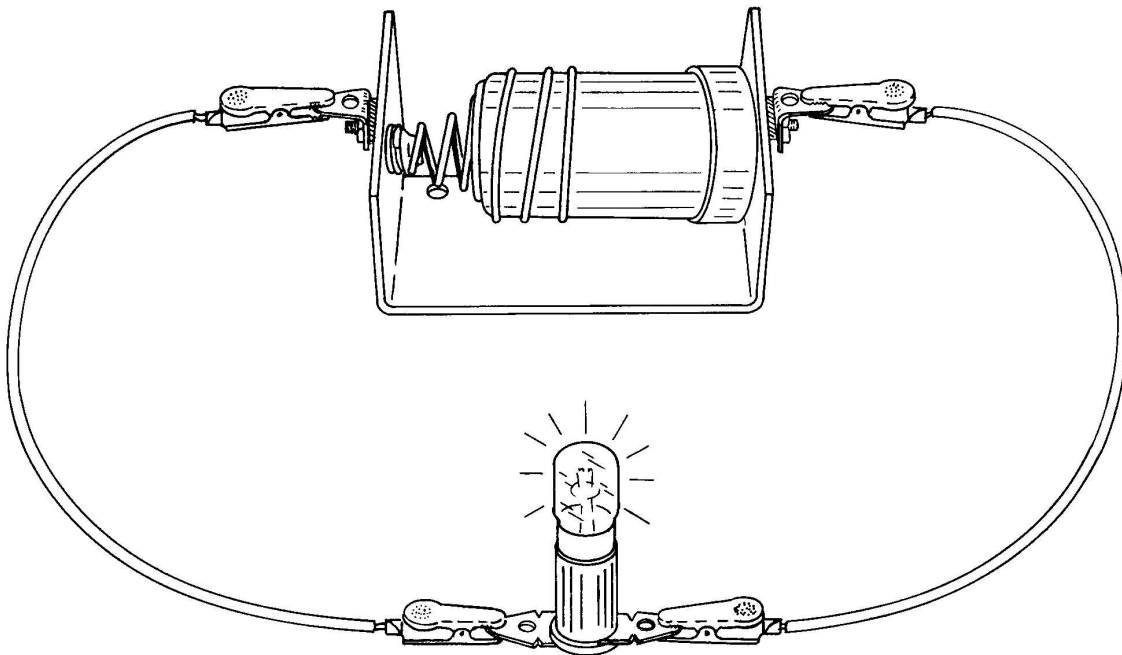

Figure 1-5

Construct the following **DIRECT CURRENT SERIES CIRCUIT**, Figure 1-6.



CLOSED CIRCUIT

Figure 1-6

NOTE: Never allow the alligator clips to touch the frame of the cell holder for if both clips touch the frame at the same time, you will be "shorting out" or "short circuiting" the cell. This means that you are making the cell give out an excessive amount of electrons. The result is that the device the cell is to operate will not function properly or will not function at all and the cell could be ruined if this shorted condition were to remain for any amount of time.

Insert the lamp into its socket, turning it to make sure that the pins are locked in place. The lamp should now be glowing and will continue to glow until the circuit is broken. This is done when the lamp is removed from its socket or when one of the two wires going from the socket to the cell is disconnected. Do not leave the lamp burning for long periods of time; this precaution will prolong the life of the cell. If this circuit were to be used commercially, a switch would have to be inserted in the circuit to turn the lamp on and off, since you will agree that removal of the lamp is not the accepted way of turning it off.

Fasten a #6 solder lug under each bolt on the knife switch. Position the lugs as shown in Figure 1-7.

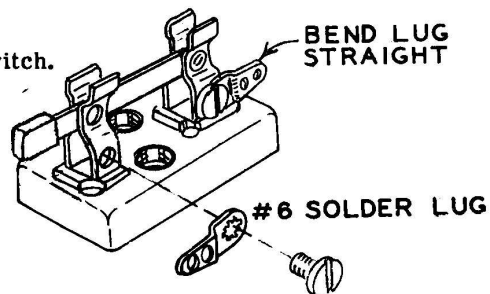

Figure 1-7

Construct the circuit of Figure 1-8A and note the actions of the switch and lamp as the switch is opened and closed.

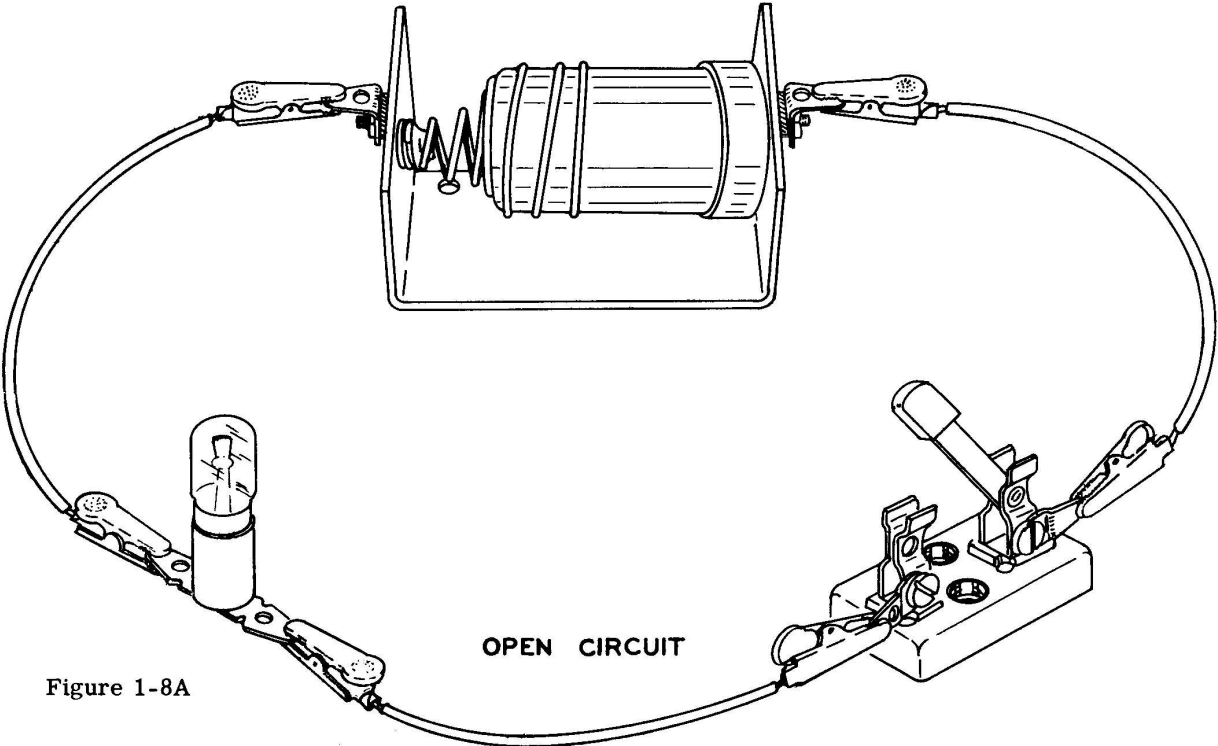

Figure 1-8A

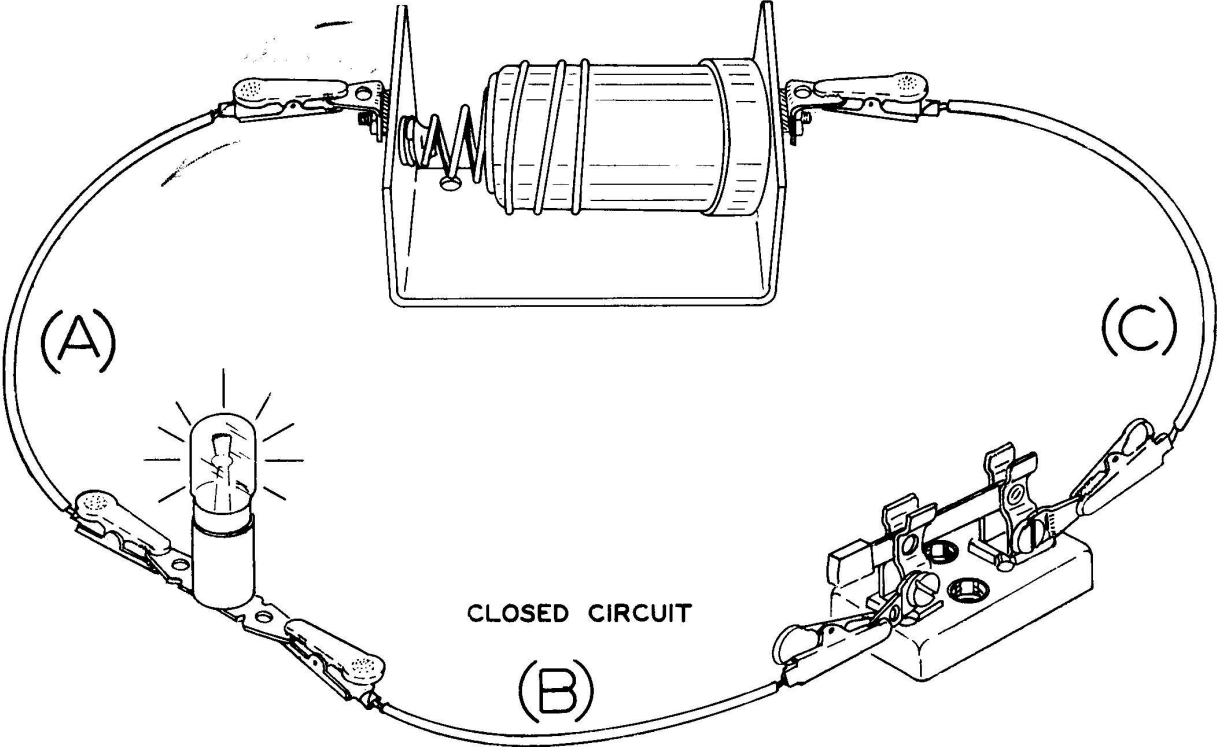

Figure 1-8B

The circuit of Figure 1-8B is a direct current series circuit because the flashlight cell delivers a continuous flow of electrons in one direction (direct current) and this flow of electrons passes through each part of the circuit in succession. In other words, the steady flow of electrons comes from the spring-connected end of the cell and flows through wire (A), then the lamp, wire (B), switch, wire (C) back into the center raised portion of the flashlight cell.

We will examine the different parts of the direct current series circuit just constructed by first discussing the flashlight cell, then the lamp and finally the connecting wires.

THE FLASHLIGHT CELL:

The most common type of flashlight cell is pictured below.

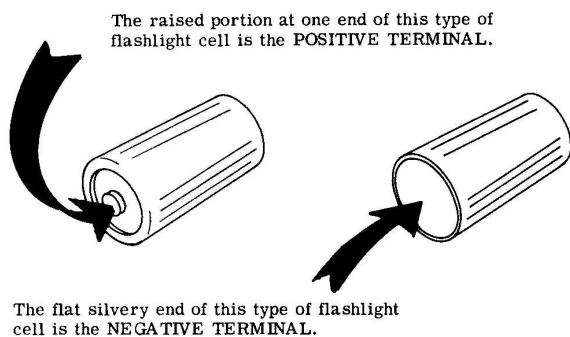
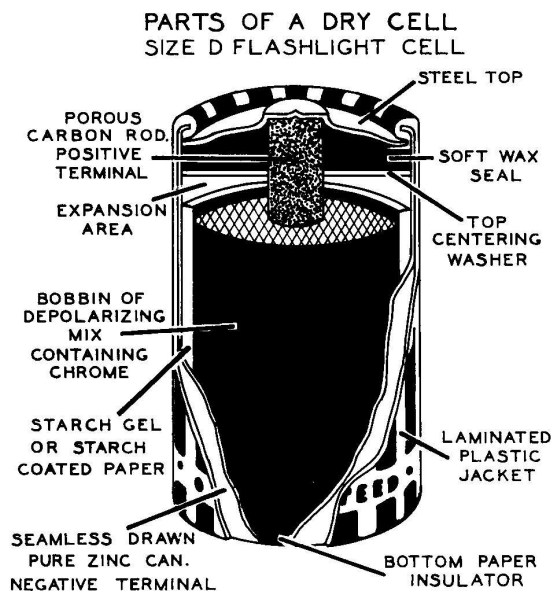

Figure 1-9

As is indicated in Figure 1-9, the flashlight cell has two terminals (places where electrical connections are made). The center raised portion at one end of the cell is the positive terminal and the flat silvery end is the negative terminal. Observe Figure 1-10 and notice that the (+) terminal is at one end of the carbon electrode (e-lek-trōd) and that the (-) terminal is at the middle of the zinc electrode.



(COURTESY BURGESS BATTERY CO.)

Figure 1-10

The negative electrode is nothing more than a zinc container that holds the rest of the cell, and in this way serves two purposes. Even though this type of cell is often referred to as a "dry cell", it is not dry on the inside but contains a moist paste. However, a wax seals off the open end of the zinc container, holding back any liquid that would ooze out when the cell is used in a horizontal position. It is for this reason that the term "dry cell" has been applied to this type of cell. An example of a "wet cell" would be one of the cells in an automobile battery. This type of cell can never be positioned on its side for the liquid within the cell will readily escape.

The function of the flashlight cell is to cause electrons to flow through a closed circuit. By chemical action some of the zinc atoms give up two of their electrons, causing an excess of electrons to accumulate on the zinc electrode. Since there are more electrons than protons on the zinc electrode, the zinc electrode exhibits a negative charge. Again by chemical action, electrons are taken from the carbon rod, causing a deficiency of electrons to exist at the carbon

electrode. Because there is a deficiency of electrons at the carbon electrode, there must be an excess of protons, and this causes the carbon rod to exhibit a net positive charge. Eventually, the chemical action within the cell destroys most of the zinc electrode, at which time the cell becomes worn out. The carbon electrode is not affected by the chemical action. Consult high school and college chemistry books if you desire to pursue the chemistry of the flashlight cell any further.

Because of the positive and negative charges existing at the two electrodes, an electrical pressure or "electromotive force" (abbreviated emf) is said to exist between the two electrodes.

To explain the idea of pressure in a physical way, let us observe Figure 1-11A.

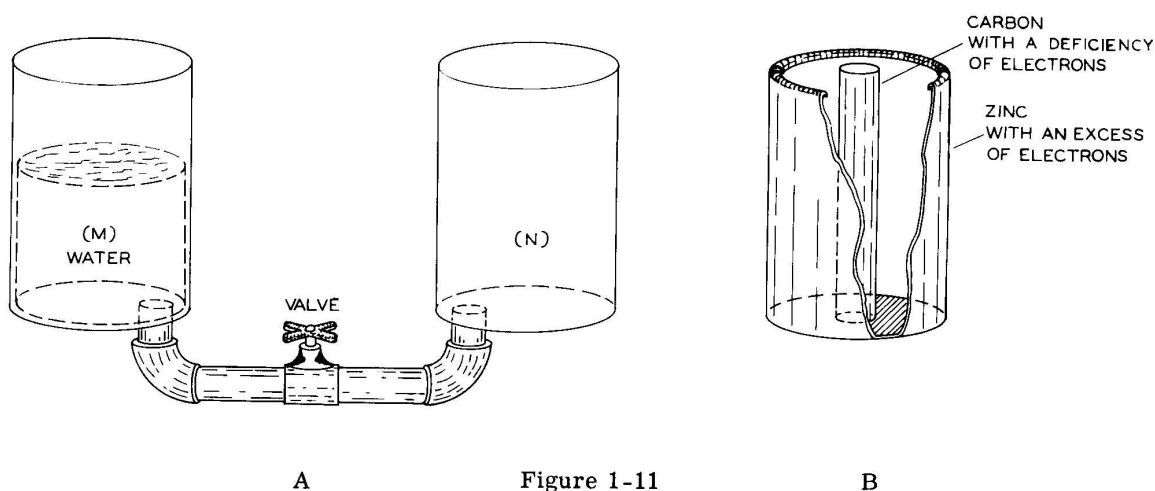

With the valve closed and tank M filled with water, as shown, we know that a pressure exists against the valve for if it is opened, water will flow into tank N. Therefore, a pressure exists between M and N because an excess of water exists in tank M and a deficiency of water exists in tank N. Tank M, with its excess of water, would compare with the zinc electrode (Figure 1-11B) and its excess of electrons while tank N, with a deficiency of water, compares with the carbon electrode and deficiency of electrons. If we open the valve, the water in tank M will flow into tank N until the level of water in both tanks is the same. At this time, no difference of pressure exists at the valve as the water has stopped flowing through the valve. The same condition can exist in the dry cell if we use the dry cell for several hours, as in Figure 1-6, or short it by connecting a wire from one terminal to the other for five or ten minutes. If the cell is allowed to rest for several hours or longer, the chemical action will have restored an excess of electrons on the zinc container and a deficiency of electrons on the carbon rod, at which time the cell is again useable.

The term "volt" was defined as a measurement of electrical pressure, just as the term "mile" was defined as a measure of distance. In a new flashlight cell when the chemical and electrodes are new, the electrical pressure between the negative and positive terminals will be high as 1.55 volts. As the cell ages, it is not capable of creating the excess and deficiency of electrons on the electrodes as fast and therefore, the pressure will decrease and approach zero. When applying a load (any device that uses up electrical energy, in this case a lamp) between the two terminals of the flashlight cell, Figure 1-12, the electrical pressure between the terminals forces electrons to flow through the lamp, with the result that light is emitted from the lamp.

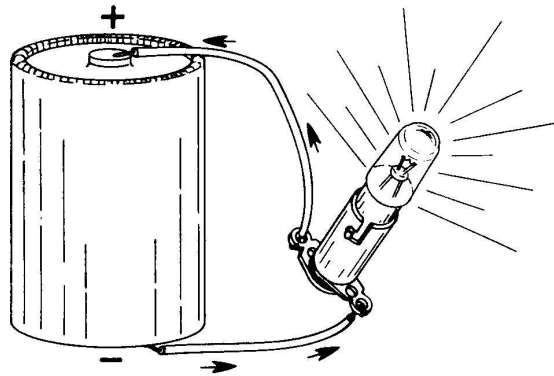

Figure 1-12

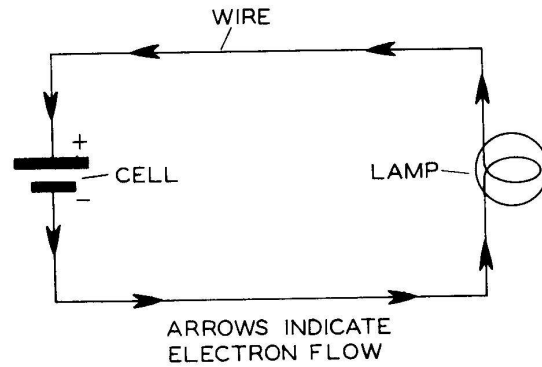

Figure 1-13

In Figure 1-12 the arrows show the excess of electrons coming from the negative terminal flowing through the wire, the light bulb, the wire again and entering the positive terminal of the flashlight cell.

Figure 1-12 has been drawn in pictorial form but showing electrical circuits in this manner is cumbersome. Symbols have been devised for each electrical item. Figure 1-13 is a schematic diagram of Figure 1-12 with symbols replacing the cell, lamp and wire.

Arrows are omitted from the schematic diagram for it is understood that electrons flow from the negative terminal of the electrical source to the positive terminal of the electrical source. Note the symbol for the cell in that the long line represents the positive electrode while the short line represents the negative electrode.

Now that you have some knowledge of the type of direct current source of energy used in the circuit just constructed, our attention will be directed to the lamp.

THE ELECTRIC LAMP:

One device for changing electrical energy into light energy is the electric lamp. Figure 1-14A is a labeled view of the #47 lamp.

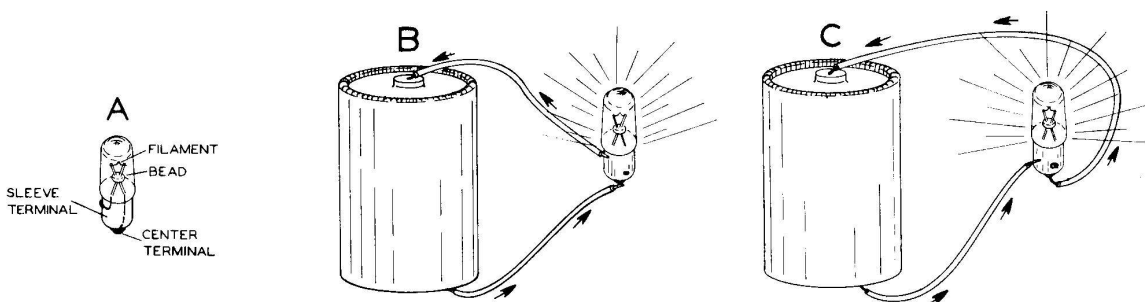

Figure 1-14

In Figure 1-14B, the lamp has been connected so that electrons flow into the center terminal through the filament and out of the sleeve terminal, while in Figure 1-14C the reverse is taking place. It makes no difference to the lamp which way the electrons flow. When electrons flow

through a circuit, it is referred to as an electric current. In order to get the quantity of light specified by the manufacturer, a certain amount of electric current must flow through the filament. In the case of the #47 lamp, a charge of approximately 938,000,000,000,000 electrons must flow through the filament for each second that the lamp is lit. To talk about negative electricity in terms of the charge of so many electrons would be quite cumbersome and, therefore, the unit coulomb was defined to represent the total charge of approximately 6,250,000,000,000,000 electrons. It is necessary to define a certain amount of electricity just as it is necessary to define the quart as a certain amount of liquid. Now we must go a step further. If the coulomb of negative electricity takes a long time to flow through the filament of the lamp, it may never heat the filament enough for the human eye to detect light. Suppose the opposite condition prevails, such that one coulomb of negative electricity moves through the filament in a short time. The filament might be heated to such a high temperature that it would evaporate while creating a very bright flash of light.

It should be apparent that the amount of time required for the coulomb to flow through the filament is the determining factor as to whether the filament operates at its correct temperature, burns out, or whether no visible light is emitted. The unit "ampere" was defined to represent the flow of one coulomb per second past a point of a circuit.

In summary, then, the charge of approximately 6,250,000,000,000,000 electrons = one coulomb and one coulomb per second (past a point of a circuit) = one ampere.

In terms of amperes, the #47 lamp will emit the correct amount of light when a current of 15/100 ampere (0.15 ampere) is flowing through it.

To better acquaint ourselves with the ampere, let us again go to a physical analogy. Suppose that we set up some one-quart milk bottles, filled with water, so that they are within reach. It will be our job to fill a vat that drains into a machine at the rate of one quart per second. The word "per" indicates division. One quart per second would mathematically be written

$$1 \text{ quart} \div 1 \text{ second or } \frac{1 \text{ quart}}{1 \text{ second}}$$

This means when the clock ticks each second, we must empty another quart of water into the vat. The situation might look like Figure 1-15.

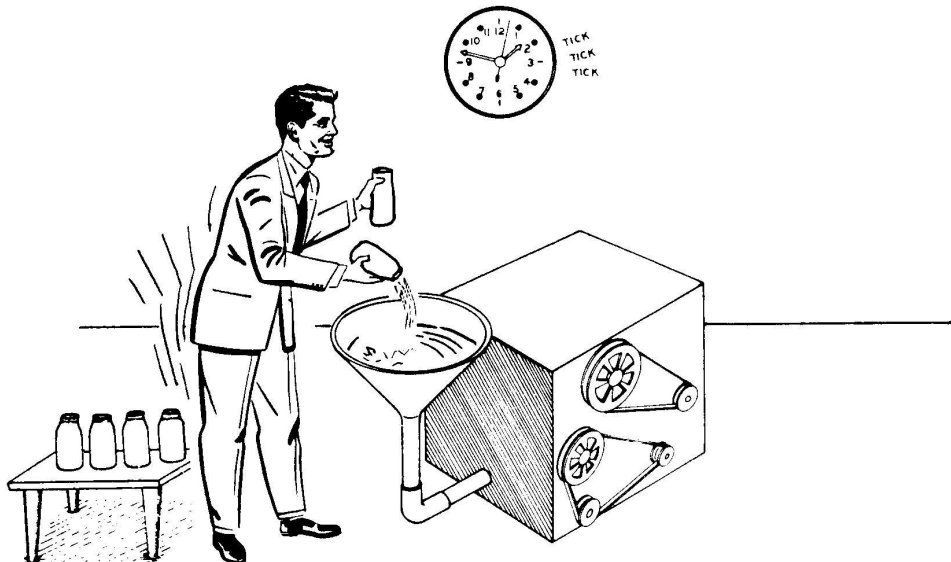

Figure 1-15

This would be quite a job, for a second does not last very long. Since sixty seconds equal a minute, it would require sixty quarts of water per minute to satisfy the machine. In the scientific sense, the pace at which something is done is called its rate and always includes two factors, such as amount and time. When one of the two factors in a rate is time, we emphasize this fact by saying "time rate". Since many things in science involve motion, most scientific rates are "time rates". In Figure 1-15, the amount is quarts and the time is the second. Therefore, the time rate is one quart per second. Actually, the idea of time rate is quite useful for we know how much of anything has been used up at the end of a certain amount of time. For example, in Figure 1-15, after ten seconds of running, the machine has used ten quarts of water; twenty seconds, twenty quarts; thirty seconds, thirty quarts, etc. The commercial way of regulating the flow of water into the machine would be with a valve and water meter. The system would look something like Figure 1-16.

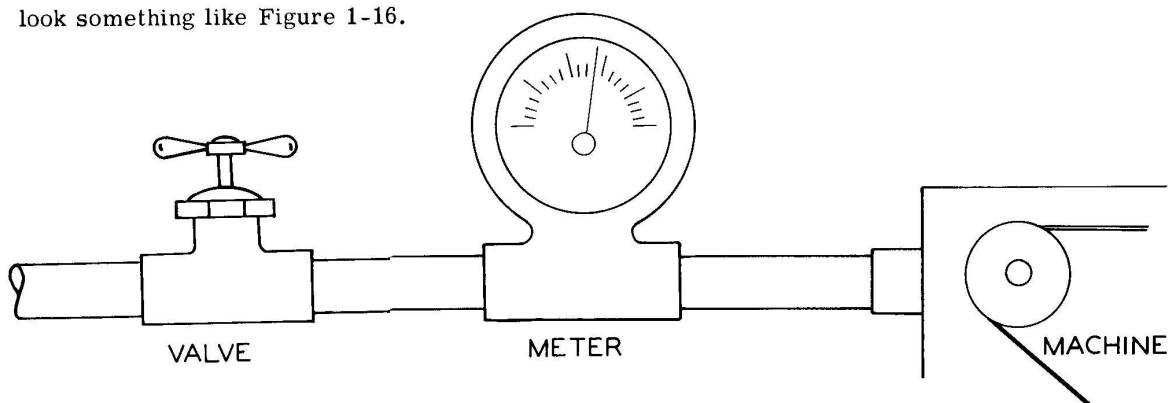

Figure 1-16

The valve is turned until the meter reads the required time rate of water flow. As was stated previously, the ampere was defined to represent one coulomb flowing past a point of a circuit per second. The ampere, then, is a time rate such as gallons per second. The ampere is mathematically written

$$\text{one coulomb} \div \text{one second} \text{ or } \frac{\text{one coulomb}}{\text{one second}}$$

In Chapter 2, an electrical meter will be used to measure the rate of electric current at any point of the circuit.

When you connected Figure 1-6 and caused the lamp to glow, you probably wondered why it did not glow very brightly. The reason is that not enough electrons were flowing through the filament to heat it to proper brilliance. To force more electrons through the filament, the electrical pressure must be increased by using more cells connected together in a string, as in Figure 1-17, so that the electrical pressure of each cell will aid the next one. Actually, six volts of electrical pressure is needed to cause the correct current of .15 amperes to flow through the filament of a #47 lamp. Since each flashlight cell develops approximately 1.5 volts of electrical pressure, it would take four flashlight cells connected in series to make 6 volts, since $4 \times 1.5 \text{ volts} = 6 \text{ volts}$. Connect the other three dry cells in series to form a battery of cells, or simply a battery, as shown in Figure 1-18.

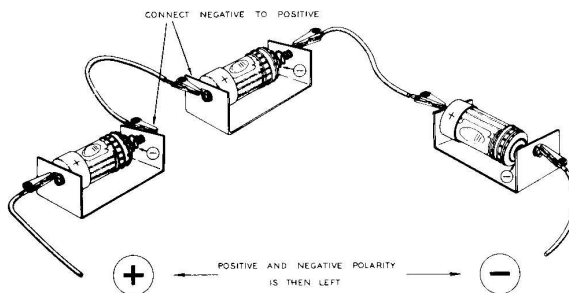

Figure 1-17

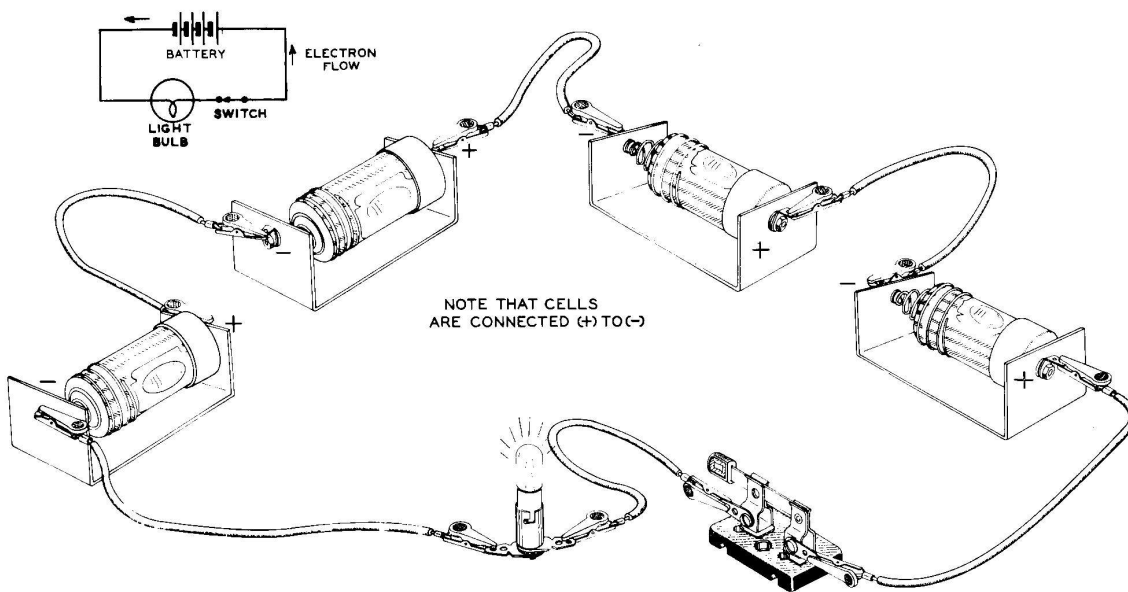

Figure 1-18

We have discussed the flashlight cell (our source of direct current), the #47 lamp (the load in the circuit), and now all that remains are the connecting wires or conductors of electricity.

THE CONNECTING WIRES:

Observe the copper atom, Figure 1-19.

Note the single electron in the N shell and that it is far away from the nucleus. Because of the distance from the N shell to the nucleus, the electrical force holding this single electron in orbit is very weak and we therefore say that this electron is loosely held to the atom. Atoms of other metals such as silver, gold, aluminum, iron etc., also have loosely held electrons in their outermost shell.

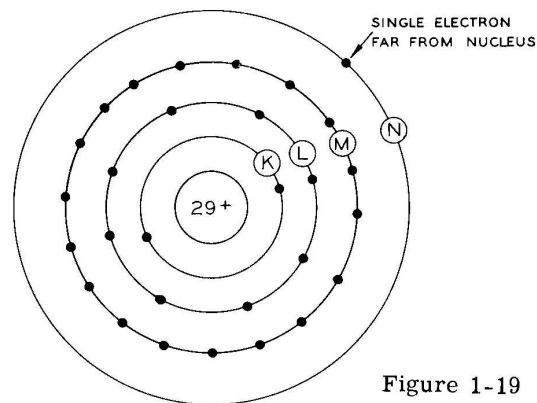

Figure 1-19

These loosely held electrons will move from one atom to the next atom freely when there is an electrical pressure applied to the ends of the metal, Figure 1-20. Metals of this type are called conductors.

As the electrons break away from the atoms, they cannot travel far before attaching themselves to other atoms. When this happens, the electron loses energy in the form of heat. This is beneficial in some cases, as with the lamp, for the hotter the filament the brighter the light. It is not beneficial to have the connecting wires get hot, for they could start a fire.

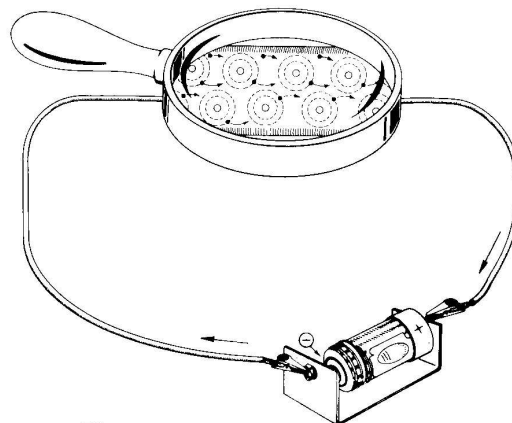

Figure 1-20

By plugging in too many appliances at one receptacle, the circuit of this receptacle can become overloaded, causing the wires to become excessively heated unless the circuit is protected by fuses. A fuse is a device that will disconnect the circuit if the current exceeds the capacity of the fuse. For example, a 15 ampere fuse will open the circuit if sixteen or seventeen amperes are flowing through the fuse. Fifteen ampere fuses are recommended for lighting circuits, thirty ampere fuses for hot water heaters and clothes dryers, and sixty ampere cartridge fuses for electric stoves. Everyone should know where the fuse box is located in his home, for this is the place where all of the current for the home can be shut off in case of trouble. Figure 1-21 illustrates various types of fuses and the fuse box.

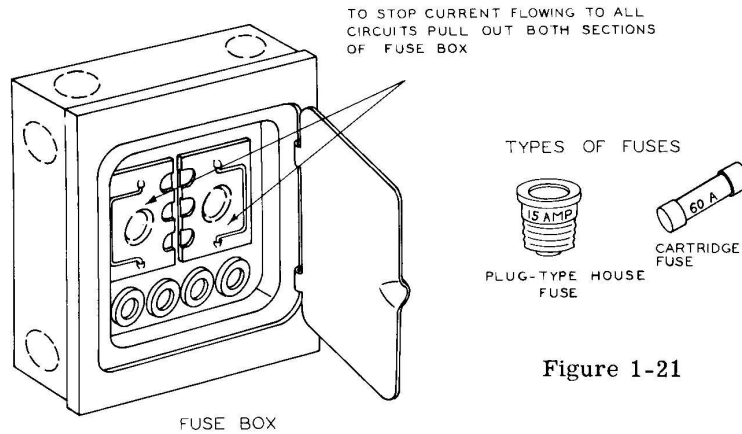

Figure 1-21

We can now see that using amperes in place of the charge of so many electrons per second is a big help in talking about current flow. The following is a list of home appliances and the amount of current in terms of amperes that these appliances normally use.

100 watt light bulb.....	0.9 ampere
Toaster.....	10 amperes
Waffle Iron.....	15 amperes
Flatiron.....	10 amperes
Television set.....	2 amperes
Hot water heater.....	20 amperes
Electric range (with 4 burners and oven turned on).....	40 amperes

Electrons in the outermost shell of the atoms of some materials are held to the rest of the atom probably because their outer shell is completely filled with electrons by "chemical" means. Since these electrons are tightly bound, it is almost impossible to make any of the electrons move from atom to atom. For all practical purposes, this type of material will not allow current to flow. It is for this reason that these materials are called insulators. Insulating materials such as rubber and plastics are used to cover the copper or metal conductor, or are used in some way to control the path of current.

To summarize, then, a direct current series circuit is composed of (1) some electrical source that will deliver a continuous flow of current, (2) a load, and (3) connecting wires such that the current flows through the circuit from one place to the next place in succession.

THE DIRECT CURRENT PARALLEL CIRCUIT

In the parallel or "shunt" circuit, the current that comes from the electrical source divides and takes two or more paths through the various loads before it returns to the same electrical source. In Figure 1-22, we see that two lamps have been connected so that the current from the electrical source divides and flows through each lamp. With connecting wires, socket, and lamp revise your circuit of Figure 1-18 to correspond with Figure 1-22.

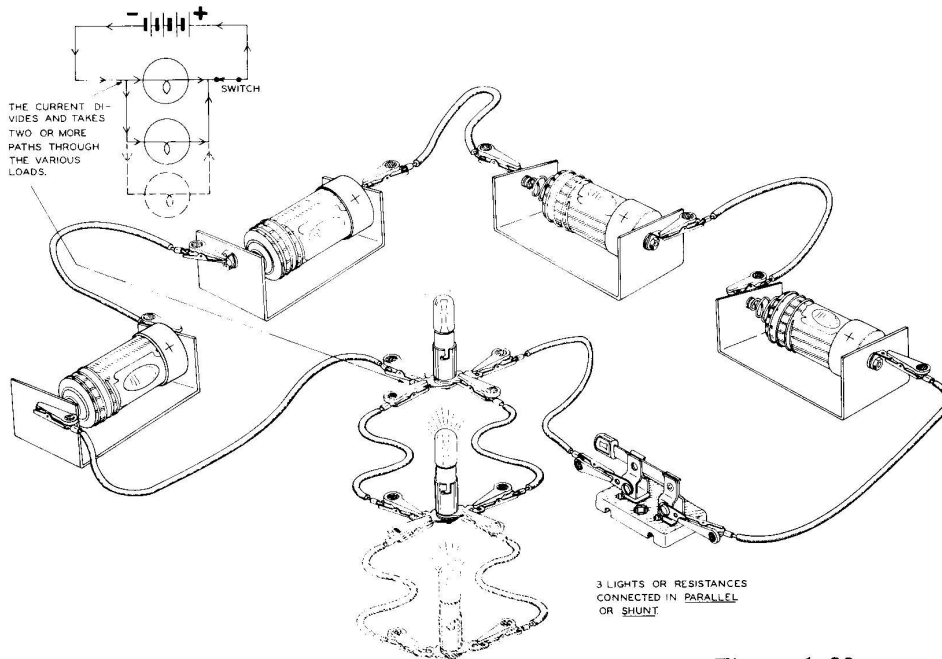

Figure 1-22

The dotted line indicates how a third lamp could be connected in parallel with the other two. Now remove one of the two lamps and notice that the other lamp stays lit. This would not be true if the lamps were connected in series as in Figure 1-23, for removing one lamp would stop the current from flowing through the other lamp. Verify this statement by constructing the circuit of Figure 1-23.

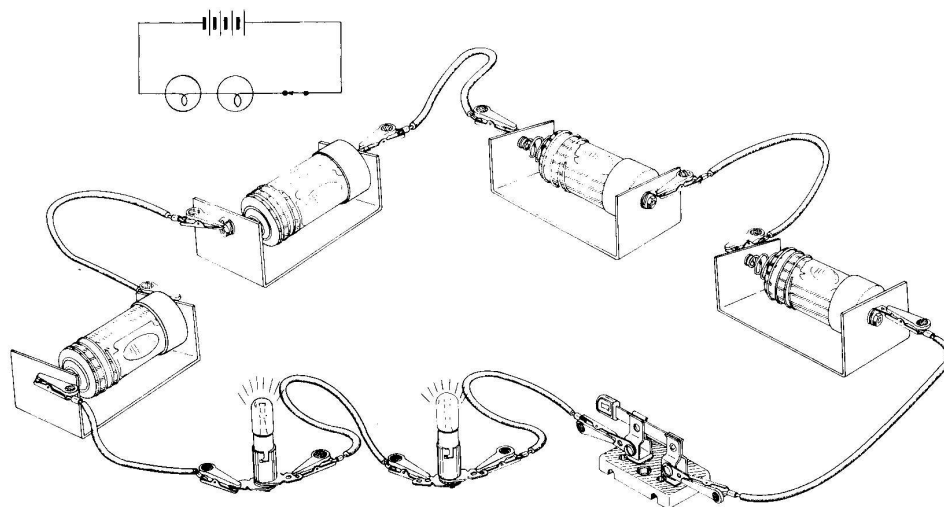

Figure 1-23

Many of the older type Christmas tree lamps were connected in series and when one lamp burned out the entire string of lamps would be out. It was customary to take a lamp that was known to be good, and starting at one end of the string, replace each lamp until the string of lamps lit up.

When one lamp burns out in a string of parallel connected lamps, the rest of the lamps stay lit; thus, the burned out lamp can be quickly identified. The headlamps in the automobile are connected in parallel so that when one lamp burns out the other lamp is not affected. The same is true of the two tail lights.

You realize, of course, that only a limited number of lamps could be connected in parallel across the flashlight cells, since the greater the number of lamps using current, the faster the cells run down. The chemical action necessary to replenish the electrical pressure between the two terminals of each cell can only work so fast, and if more current is removed than can be replaced, the electrical pressure (voltage) starts to drop. With reduced voltage, fewer electrons travel around the circuit, causing the lamps to dim. This effect is also noted when the flashlight has been left on for some time, or the cells are old and need replacing. Do not leave the lamps on for any extended amount of time until you are through with this course, as the experiments will work better with fresh cells. When the cells are no longer needed for experiments, you should use them in circuits of your own design.

To summarize, the direct current (abbreviated d-c) parallel circuit is composed of (1) a direct current electrical source, (2) two or more loads, and (3) connecting wires such that the current takes two or more paths through the various loads before it returns to the same electrical source.

CONNECTING CELLS IN PARALLEL

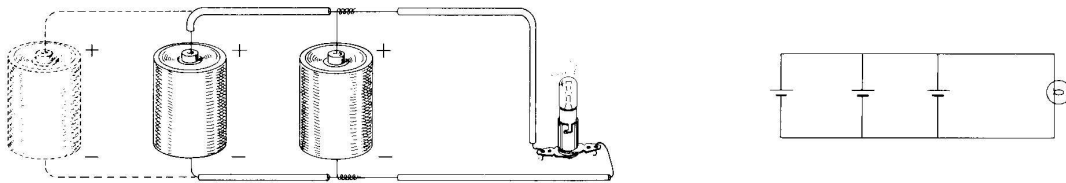

Figure 1-24A

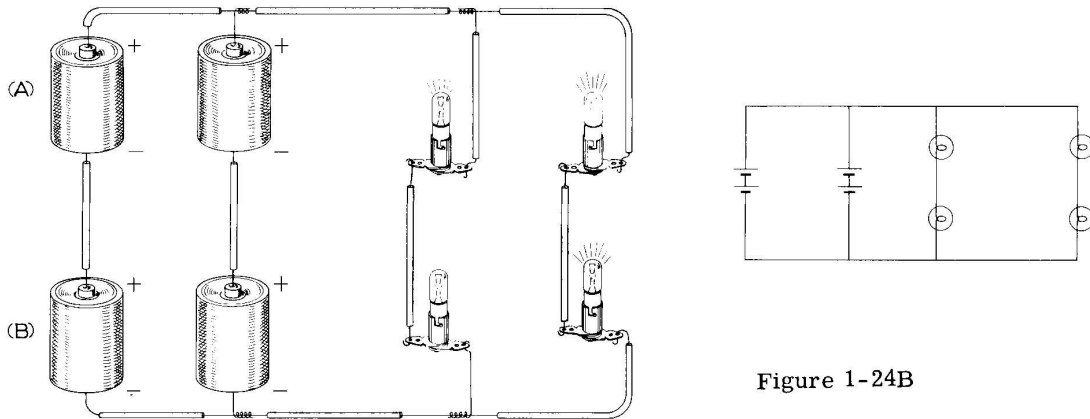

Figure 1-24B

Figure 1-24A shows cells connected in parallel. Twice as much current can be obtained with a two cell connection, but the voltage still remains 1.5 volts. In Figure 1-24B both cells and loads are series-parallel connected. Here the series connection of cells gives twice the voltage of one cell (3.0 volts) and parallel connecting the series cells results in twice the current available. If cells A and B were removed, the remaining cells would be used up twice as fast.

THOUGHT QUESTIONS

1. If a table lamp and a radio are plugged into the same wall outlet, are they connected in series or parallel at the outlet? Why?

Answer: They are connected in parallel for either appliance can operate without the other being on. If they were connected in series both appliances would have to be on at the same time.

2. Observe the following figure. Would the lamp function? Why?

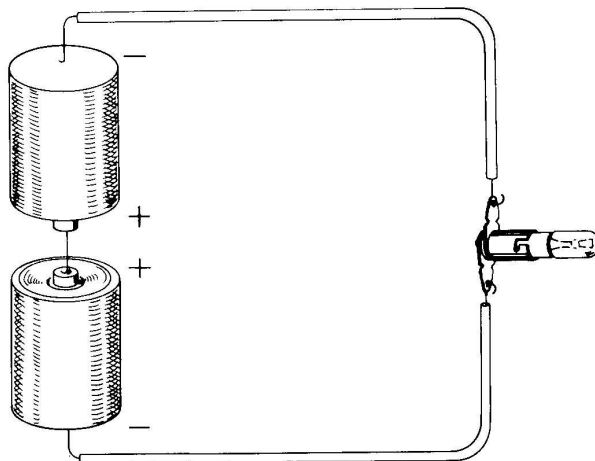

Answer: The lamp will not function because the electrical pressure of one cell cancels the electrical pressure of the other cell and under this condition no current is able to flow through the lamp (notice the opposing polarity of the two cells).

THINGS TO DO

1. When you are in a store that sells electrical equipment, look at the counter displaying fuse boxes, fuses, switches, sockets, plugs, etc. This will acquaint you with electrical equipment.
2. Using a hacksaw, cut through the center of a worn out flashlight cell and observe its construction.

NOTE: At the end of each chapter are two sets of questions. The second set of questions with answers has been inserted upside down so that a person opposite you can check your verbal answers. If you can answer all of the following questions correctly, it may be assumed that you understand the material in this chapter very well.

QUESTIONS FOR CHAPTER 1

1. What two things make up the nucleus of an atom?
2. What is the name of the particle that whirls around the nucleus?
3. Describe the oxygen atom.
4. What makes one atom different from another atom?
5. What specifically is it that makes the lamp light up?
6. What should be used in the circuit to turn the lamp on and off?
7. The zinc electrode is called the _____ electrode and the carbon rod is called the _____ electrode.
8. Why has the term "dry cell" been applied to the flashlight cell?
9. The chemical action within a dry cell causes an excess of electrons to exist at the _____ electrode and a deficiency of electrons at the + electrode.
10. Because of the positive and negative charges existing at the two electrodes, an electrical pressure is said to exist between the two electrodes.
11. How may the electrical pressure of a dry cell be made to decrease? 1.2
12. What term was defined so that the amount of electrical ^{volt} pressure or "EMF" could be measured? coulomb
13. What is the pressure in volts of a new flashlight cell? 1.55
14. What represents a load in the first electrical circuit constructed?
15. Starting with the cell, describe the path of current around the series circuit of Figure 1-6.
16. Draw a schematic diagram of a series circuit using one dry cell, light bulb and connecting wires. (Check drawing with Figure 1-13, Page 8.)
17. Does it make a difference to the light bulb which way the current flows through the filament?
18. What term was defined for the total charge of approximately 6,250,000,000,000,000 electrons? coulomb
19. What term was defined to represent the flow of one coulomb per second past a point of a circuit? ampere

1. What two things make up the nucleus of an atom? Answer: One or more positively charged particles and neutral particles. Alternate answer: (protons and neutrons)
2. What is the name of the particle that whirls around the nucleus? Answer: electron.
3. Describe the oxygen atom. Answer: The oxygen atom has eight protons and eight neutrons forming the nucleus and eight electrons whirling around the nucleus in two different shells.
4. What makes one atom different from another atom? Answer: Atoms differ from one another because they have different numbers of electrons, protons and neutrons.
5. What specifically is it that makes the lamp light up? Answer: The charge of the electron moving through the filament inside the lamp.
6. What should be used in the circuit to turn the lamp on and off? Answer: A switch.
7. The zinc electrode is called the negative electrode and the carbon rod is called the positive electrode.
8. Why has the term "dry cell" been applied to the flashlight cell? Answer: The cell is sealed off in such a way that the liquid within it will not ooze out when the cell is in a horizontal position.
9. The chemical action within a dry cell causes an excess of electrons to exist at the negative electrode and a deficiency of electrons at the positive electrode.
10. Because of the excess and deficiency of electrons existing at the two electrodes, an electrical pressure is said to exist between the two electrodes.
11. How may the electrical pressure of a dry cell be made to decrease? Answer: By using the dry cell for several hours or by shorting it by connecting a wire from one electrode to the other.
12. What term was defined so that the amount of electrical pressure could be measured? Answer: Volt.
13. What is the pressure in volts of a new flashlight cell? Answer: 1.55 volts.
14. What represents a load in the first electrical circuit constructed? Answer: The lamp.
15. Starting with the cell, describe the path of current around the series circuit of Figure 1-6. Answer: The electricity flows from the negative terminal through a wire, light bulb, wire again, and enters the positive terminal of the flashlight cell.
16. Draw a schematic diagram of a series circuit using one dry cell, light bulb and connecting wires. (Check drawing with Figure 1-13, Page 8.)
17. Does it make a difference to the light bulb which way the current flows through the filament? Answer: No.
18. What term was defined for the total charge of approximately 6,250,000,000,000,000 electrons? Answer: Coulomb.
19. What term was defined to represent the flow of one coulomb per second past a point of a circuit? Answer: Ampere.

QUESTIONS FOR CHAPTER 1

20. How much current in amperes must flow through the filament of the #47 lamp in order for it to be at proper brilliance? *1.3*

21. The pace at which something is done is called its rate.

22. When one of the two factors in a rate is time, we emphasize this fact by saying per unit.

23. How is the ampere mathematically written? *ampere - A*

24. What condition prevails in the outermost shell of electrons of most metal atoms, such that they are called conductors? *loose*

25. What is a fuse? *safe device*

26. Why should everyone know where the fuse box is located in his home?

27. How much current does a 100 watt lamp use? *0.9 ampere*

28. Name two insulating materials that are used to cover a metal conductor. *rubber, plastic*

29. What three things go into making a direct current series circuit? *power source, load, wire*

30. Draw a schematic diagram of a direct current parallel circuit using four cells, two light bulbs and connecting wires. (Check drawing with Figure 1-22, Page 13.)



31. Can any number of light bulbs be connected in parallel across a flashlight cell?

32. How is direct current abbreviated?

33. What three things go into making a direct current parallel circuit? *power source, load, wire*

20. How much current in amperes must flow through the filament of the #47 lamp in order for it to be at proper brilliance? Answer: .15 ampere.
21. The pace at which something is done is called its rate.
22. When one of the two factors in a rate is time, we emphasize this fact by saying "time rate".
23. How is the ampere mathematically written? Answer: $\frac{\text{one coulomb}}{\text{one second}}$
24. What condition prevails in the outermost shell of electrons of most metal atoms, such that they are called conductors? Answer: Some of the electrons in the outer shell are loosely held to the atom and will move from one atom to the next more freely when there is an electrical pressure applied.
25. What is a fuse? Answer: A device that will disconnect the circuit if more current is flowing than should be.
26. Why should everyone know where the fuse box is located in his home? Answer: This is the place where all of the current for the home can be shut off in case of trouble.
27. How much current does a 100 watt light bulb use? Answer: 0.9 ampere.
28. Name two insulating materials that are used to cover a metal conductor. Answer: Rubber and plastics.
29. What three things go into making a direct current series circuit? Answer: (1) A source of power that will deliver a continuous flow of current, (2) a load, and (3) connecting wires such that the current flows through the circuit from one place to the next place in succession.
30. Draw a schematic diagram of a direct current parallel circuit using four cells, two light bulbs and connecting wires. (Check drawing with Figure 1-22, Page 13.)
31. Can any number of light bulbs be connected in parallel across a flashlight cell? Answer: No.
32. How is direct current abbreviated? Answer: d-c.
33. What three things go into making a direct current parallel circuit? Answer: (1) A direct current power source, (2) two or more loads, and (3) connecting wires such that the current takes two or more paths through loads before it returns to the same electrical source.

CHAPTER 2

THE DIRECT CURRENT MILLIAMMETER

To manufacture a commercial instrument, a panel with painted directions and indications is usually necessary. This is true of the Model EK-1. Study the panel and see how much of the printed material is meaningful to you.

A space () has been provided in front of each step so that you can lightly check off each operation as it is completed. This will prevent confusion if your work is interrupted. Be sure you read each step all the way through before you start to do it.

In all operations involving panel assembly and wiring, a soft cloth or pad should be placed on the working surface so that the panel will not become marred or damaged by scratching against another surface.

(✓) All banana jacks will be mounted at this time, Figure 2-1.

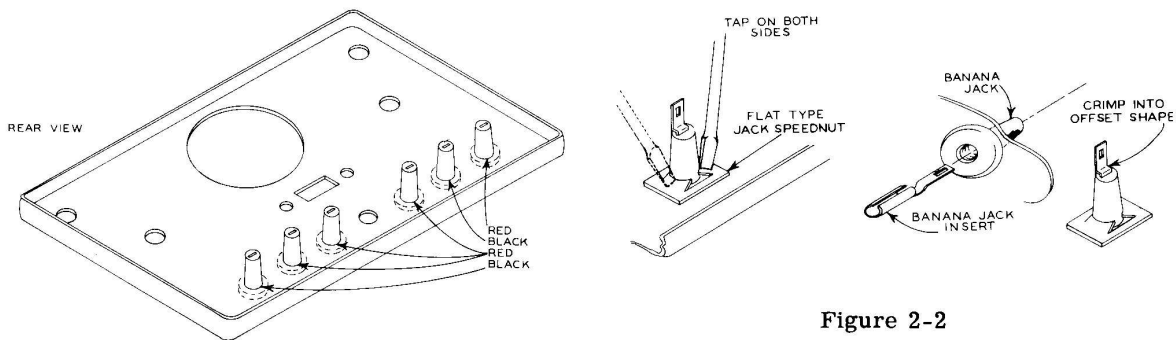

Figure 2-1

Figure 2-2

- (✓) Holding the screwdriver against the jack speednut as shown in Figure 2-2, tap screwdriver so that both sides of speednut are forced to grip banana jack tightly.
- () Insert all banana jack inserts and bend an offset into each insert, as shown in Figure 2-2, to hold it inside the banana jack.
- (✓) Mount the push button switch as shown in Figure 2-3. Be sure the switch terminals are positioned as shown.

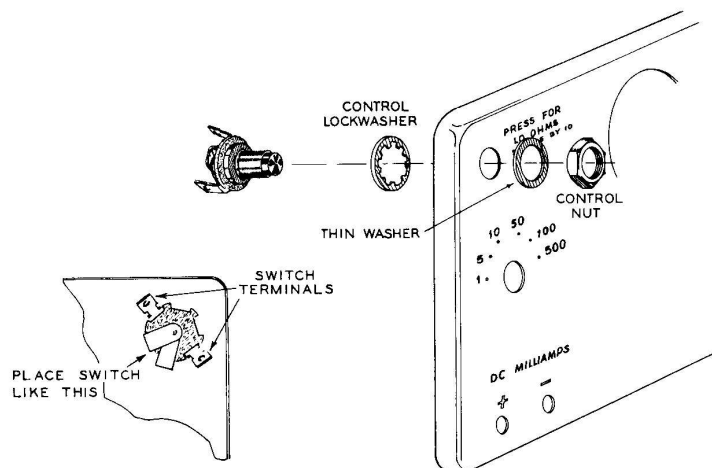
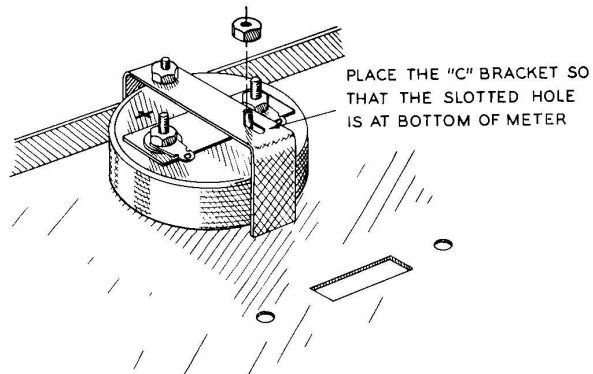

Figure 2-3

- (✓) Mount the meter, Figure 2-4, using C bracket supplied on back of meter.



- (✓) Mount the slide switch, using two 6-32 x 3/8" BHMS as shown in Figure 2-5.

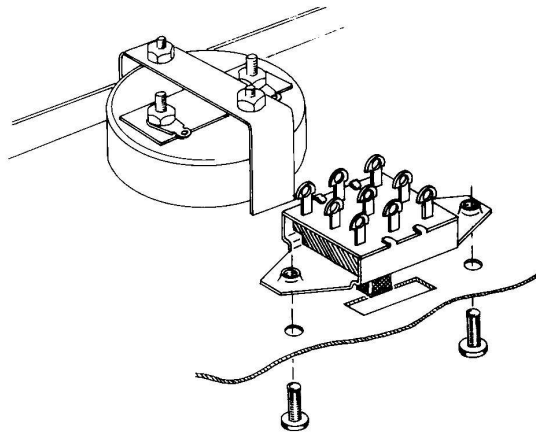

Figure 2-5

- () Insert the neon lamp, holding it in place with the small speednut, as shown in Figure 2-6.

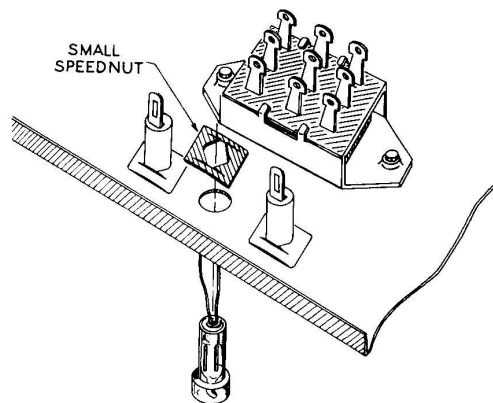
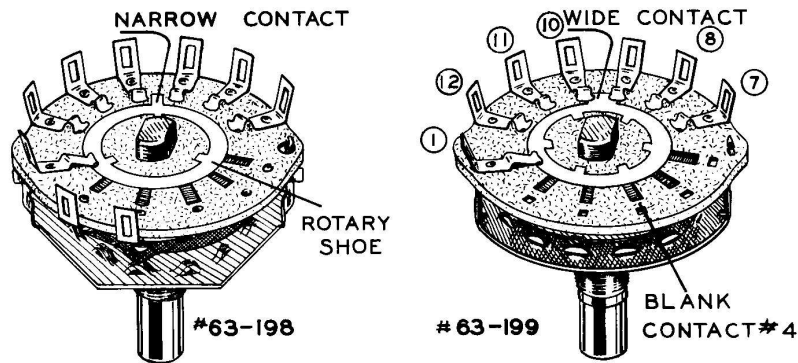

Figure 2-6

- ✓ Unpack the two rotary switches and compare them with the rotary switches in Figure 2-7, pictured below.



With narrow contact on rotary shoe, switch is called "non-shorting type" for as switch is rotated, the narrow contact will not short the fixed contacts adjacent to it.

With wide contact on rotary shoe, switch is called "shorting type" for as switch is rotated, the switch contact momentarily shorts the fixed contacts adjacent to it.

Figure 2-7 *Wide contacts*

- ✓ Fasten a large knob on the shaft of each switch and rotate the rotary contact shoe, observing the shorting and non-shorting action.
- ✓ After removing the knob, fasten the "shorting type" switch (#63-199) and battery holder bracket to the panel above the letters "DC Milliamps" with the blank contact #4 on the switch pointing between the banana jacks directly below the switch. See Figure 2-8 for mounting procedure, and switch Figure 2-7 for blank contact #4.

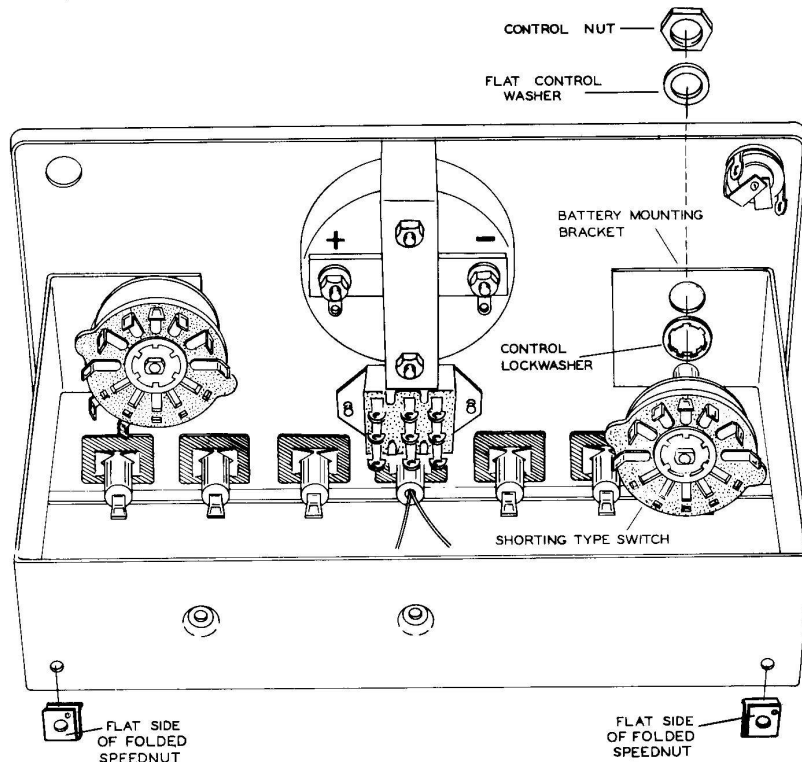

Figure 2-8

- (✓) Refasten the knob so that it correctly indicates when rotated between 1 and 500 milliamperes.
- (✓) Mount the "non-shorting type" rotary switch in the same manner as you mounted the other rotary switch. This switch fits in the hole above the letters "DC Volts-Ohms".
- (✓) Fasten the knob so that it correctly indicates when rotated between 5 and ohms.
- (✓) Connect a wire from the positive meter terminal to the red banana jack marked positive (+) (below the letters DC Milliamps) and another wire from the negative meter terminal to the black banana jack marked negative (-). See Figure 2-9. Solder these connections.

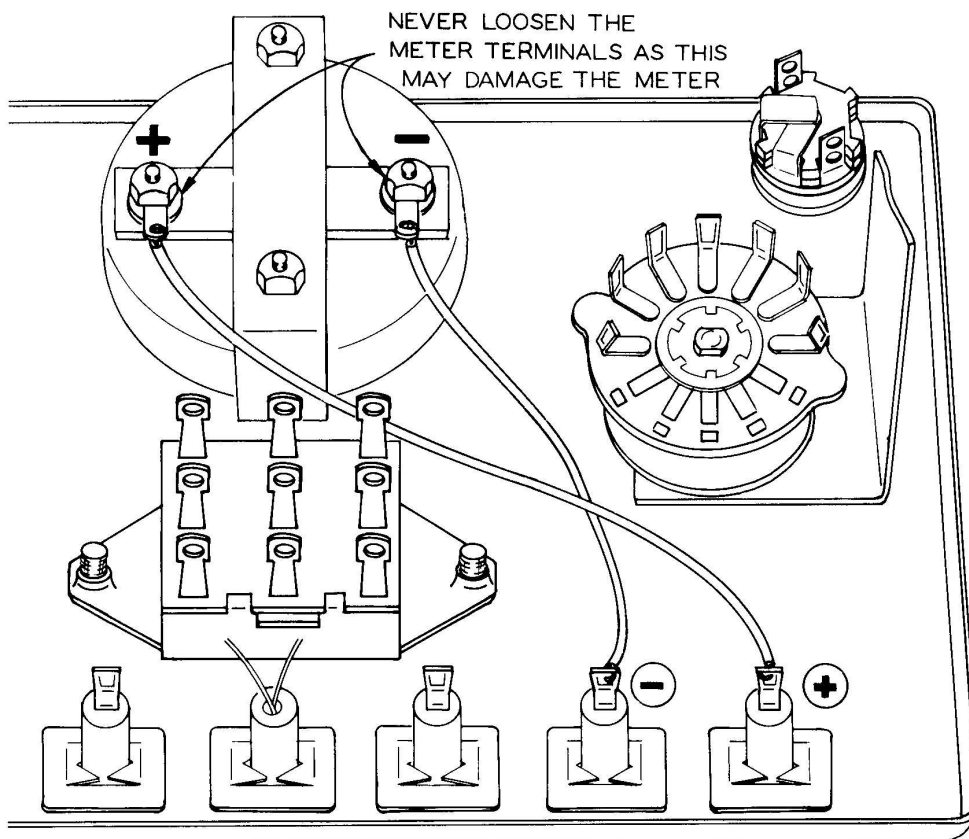

Figure 2-9

- (✓) Place the two folded speednuts on the back flange of the battery mounting bracket in line with the holes provided. See Figure 2-8.
- (✓) Insert four rubber feet into the four holes on the bottom of the cabinet, and insert the other four into the four holes (near the corners) on the back of the cabinet.
- (✓) Attach the handle with the two #10 x 1/2" screws at the top of the cabinet.
- (✓) Insert the front panel into the cabinet, holding it in place with two 6-32 x 3/8" BHMS through the holes at the back of the cabinet, and the speednuts.

U Construct the two black test leads, each 3 feet long, as shown in Figure 2-10.

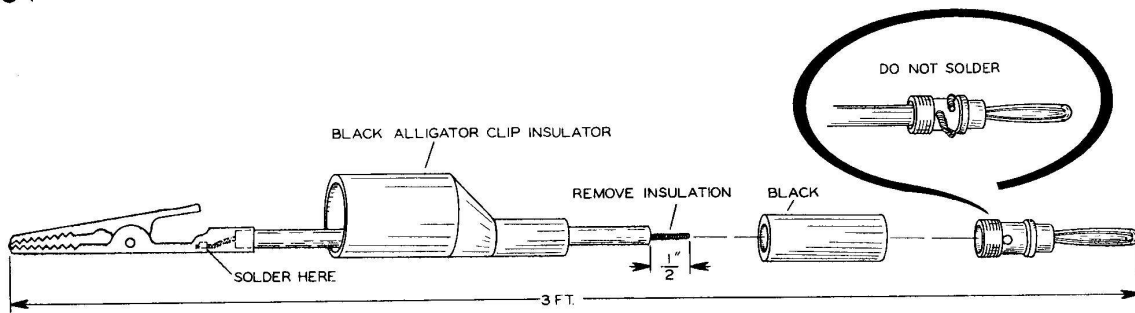

Figure 2-10

(U) Construct one red test lead 3 feet long, as shown in Figure 2-11.

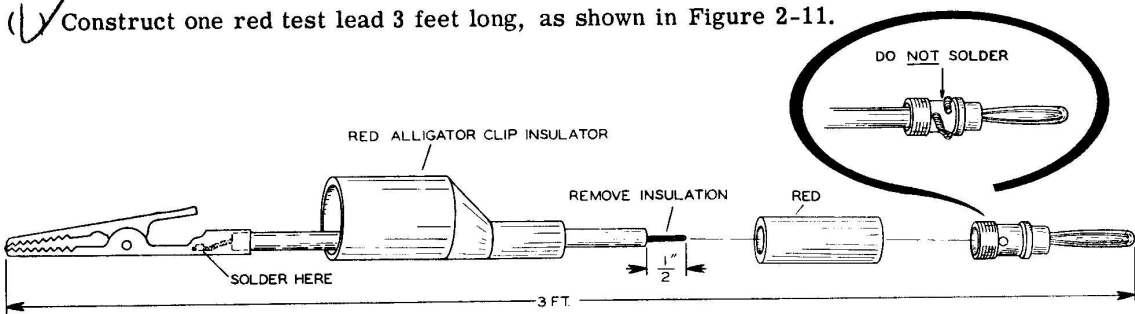

Figure 2-11

() Construct one red test lead 3 feet long, as shown in Figure 2-12.

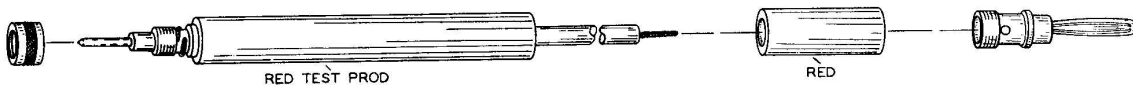

Figure 2-12

NOTE: The 1,000 ohm control is not to be mounted at this time.

() Insert one black test lead and one red test lead (with alligator clip) into the appropriate banana jacks below the letters "DC Milliamps".

Your meter has now assumed the electrical situation shown in Figure 2-13.

Figure 2-13

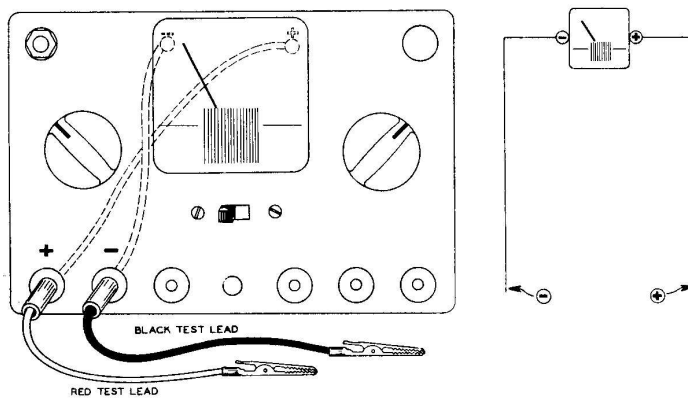

How the Meter can indicate the rate of flow of electric current.

In 1819, Hans Christian Oersted (Er-stet), a Danish physicist, made an important discovery. He found that an electric current flowing through a conductor would deflect a compass needle placed near the conductor. He reasoned that the current flowing through the conductor was creating a magnetic field. Figures 2-14A and B illustrate his theory.

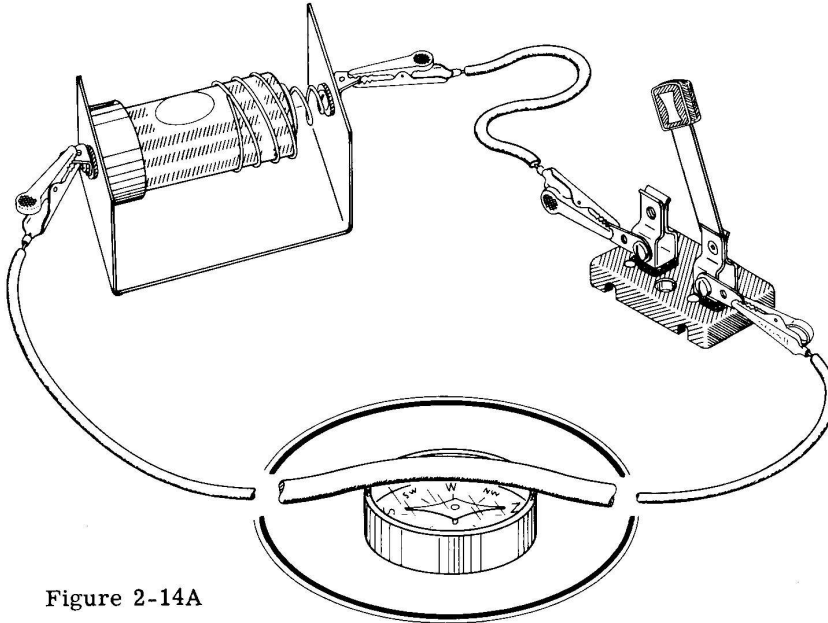

Figure 2-14A

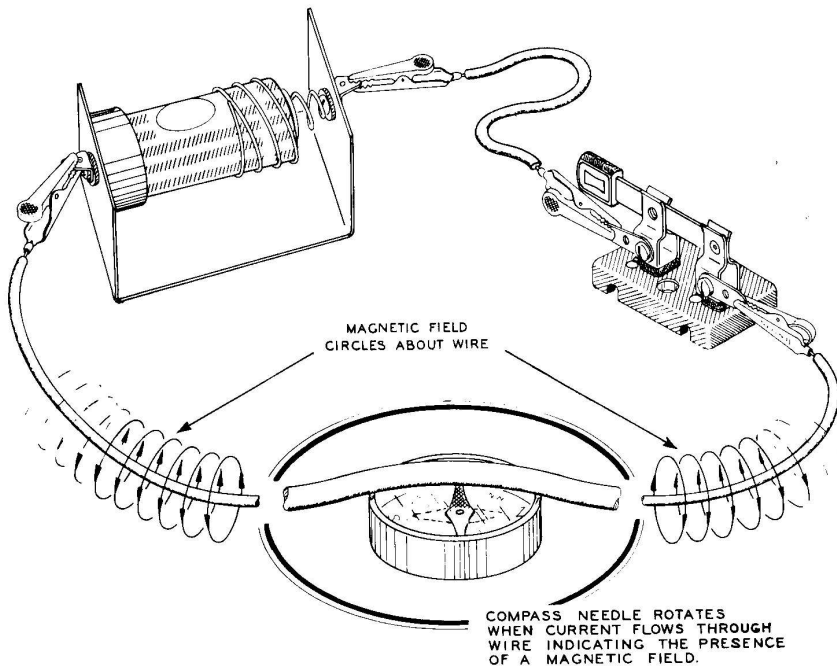

Figure 2-14B

Repeat Oersted's experiment as illustrated in Figure 2-14A and B. For best results, orient the wire so that it is in line with the compass needle when no current is flowing through the wire. This orientation of the wire will cause the needle to rotate almost a full 90° when current starts flowing through the wire. THE SWITCH SHOULD MAKE CONTACT ONLY LONG ENOUGH TO OBSERVE THE ACTION OF THE COMPASS NEEDLE.

To strengthen the magnetic field, the wire is formed into a coil. We can do this by forming the remaining length of hookup wire into a coil using a flashlight cell as a base upon which to wrap the wire, Figure 2-15A. Make the coil as narrow as possible.

Slip the coil away from the flashlight cell and wrap scotch tape or string around the wires to keep them in shape, Figure 2-15B.

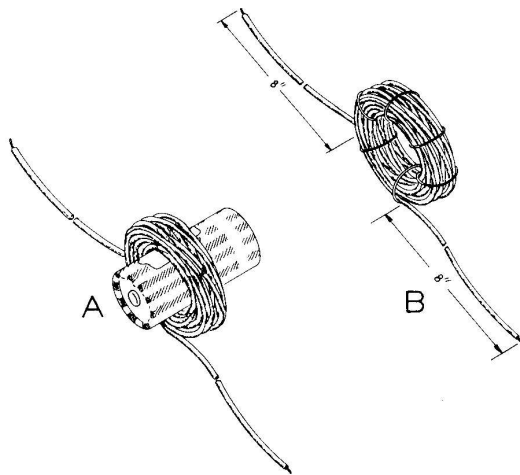

Figure 2-15

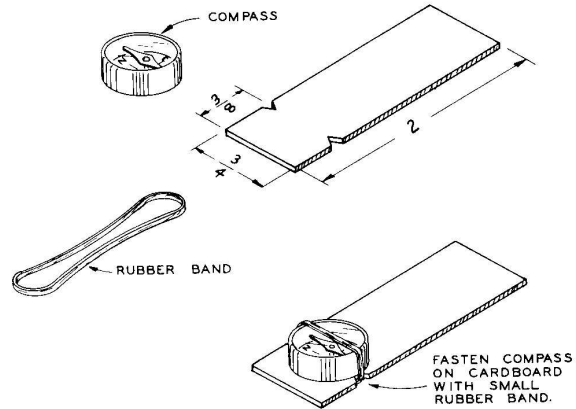

Figure 2-16

Mount the compass on a piece of cardboard as shown in Figure 2-16.

Construct the circuit of Figure 2-17A. (WHEN INSTRUCTED, CLOSE THE SWITCH ONLY LONG ENOUGH TO OBSERVE THE COMPASS INDICATIONS.)

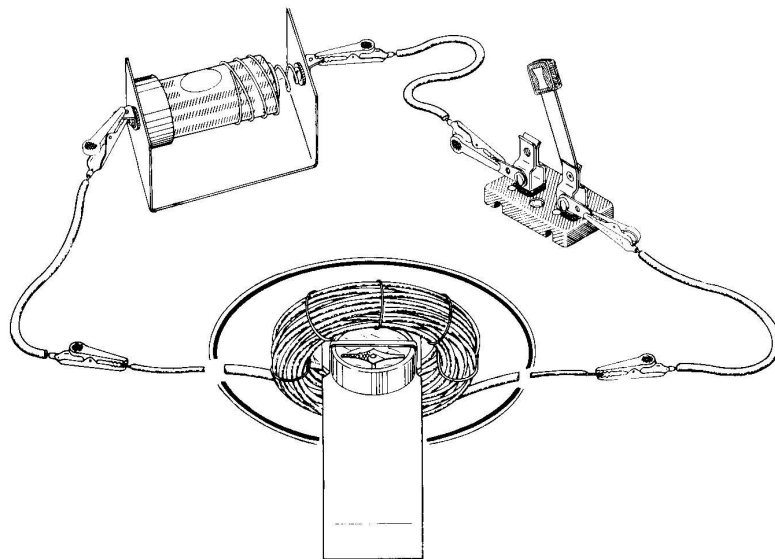

Figure 2-17A

With no current flowing, and the compass inside the coil, orient the coil and compass so that the compass needle points to the turns of wire as shown in Figure 2-17A. Now cause current to flow through the coil by closing the switch, and observe the compass needle, Figure 2-17B.

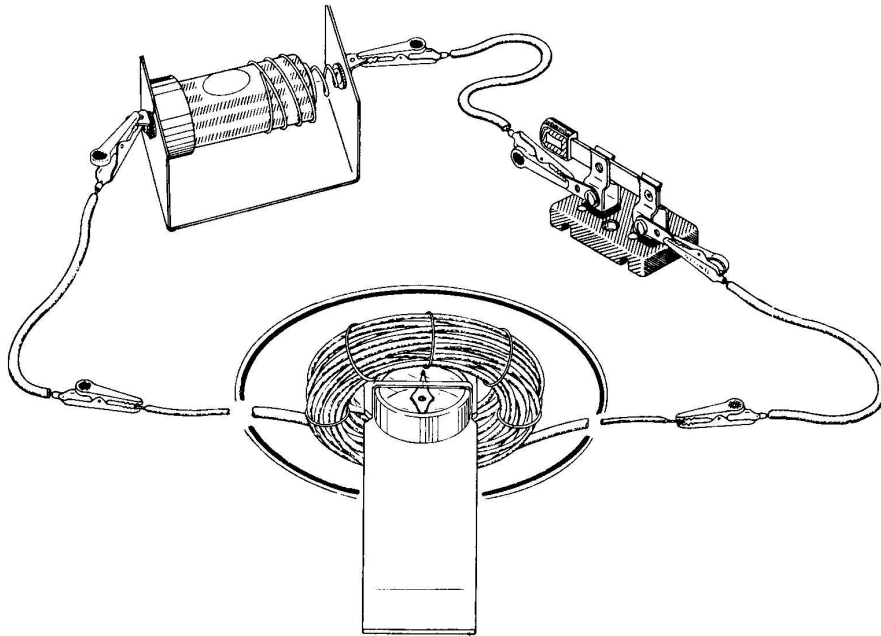

Figure 2-17B

The magnetic field of the coil is stronger at the center of the coil. This increase in the strength of the magnetic field at the center of the coil can be observed by comparing the oscillations of the compass needle at the center of the coil with oscillations of the needle at the outside rim of the coil each time the electrons start to flow through the coil, Figure 2-18A and B.

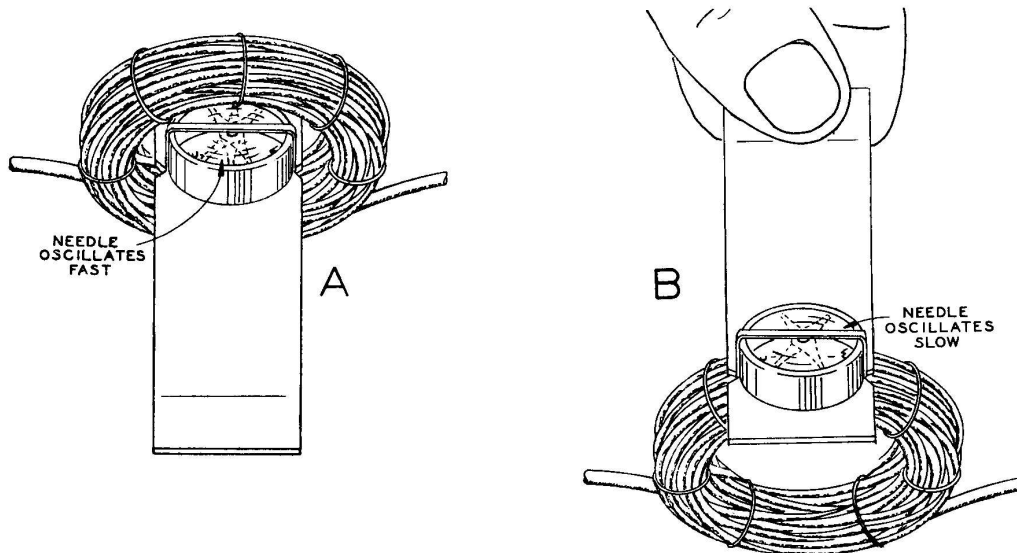

Figure 2-18

The faster oscillations at the center can only be attributed to a stronger magnetic field. Open the switch again after this observation.

The compass needle, then, is most sensitive to the magnetic field set up by the current through the coil when it is located at the center of the coil. Now let us observe the compass needle when the amount of current flowing through the coil is varied.

The "250 Ω " control will be employed to control the amount of current flowing through the coil. The 250 Ω control is nothing more than a variable resistor. A resistor is a device that resists the flow of current. Actually, all materials are resistors in a sense because all materials resist the flow of current. However, some materials resist the flow of current much more than others. For example, one type of iron wire the same size and length as copper wire resists the flow of current eight times more than copper; or, stated another way, copper is eight times better at conducting current than is this type of iron. Carbon resists the flow of current about 3000 to 4000 times more than copper, and this is the material used inside the control to vary the amount of current flowing through it.

The 250 Ω control is merely a curved path of carbon material upon which a slider rotates. Refer to Figure 2-19.

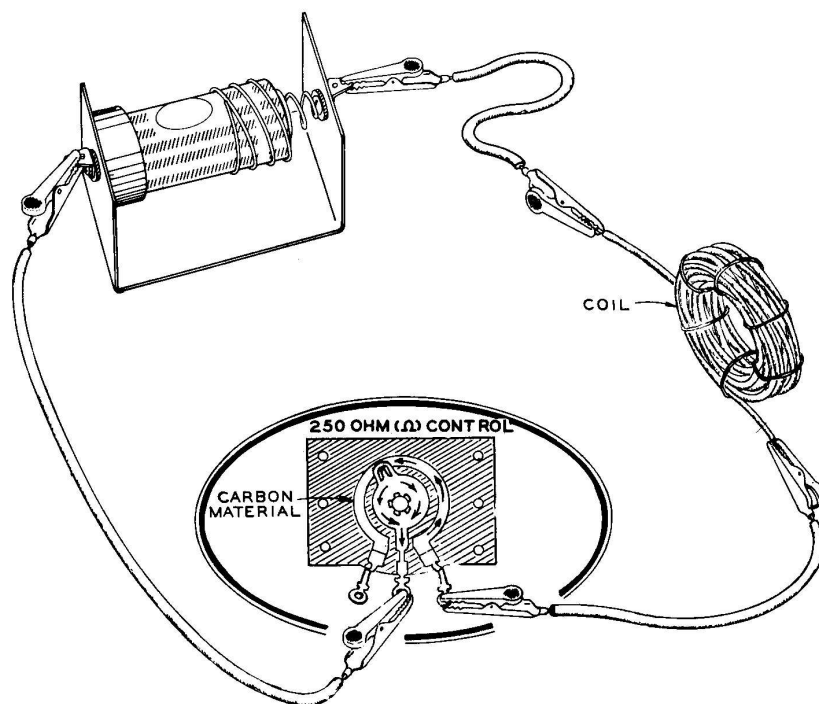

Figure 2-19

If the slider is turned clockwise (same direction that the hands of the clock rotate) by turning the knob, the carbon path is made shorter and, therefore, the resistance is decreased, thus causing the current to increase through the circuit. Moving the slider counterclockwise will increase the carbon path, hence increasing the resistance and decreasing the flow of current.

Since resistance is present in all electrical circuits and certain amounts of resistance are actually put into the circuit to control the amount of current in the circuit (the 250 Ω control, for example), it becomes necessary to define a unit of measure for resistance. The unit of measure for resistance is the ohm, named after George S. Ohm, a German physicist, as the relationship between voltage, current and resistance was first given by him. The Greek symbol Ω represents ohms.

Construct the circuit of Figure 2-20.

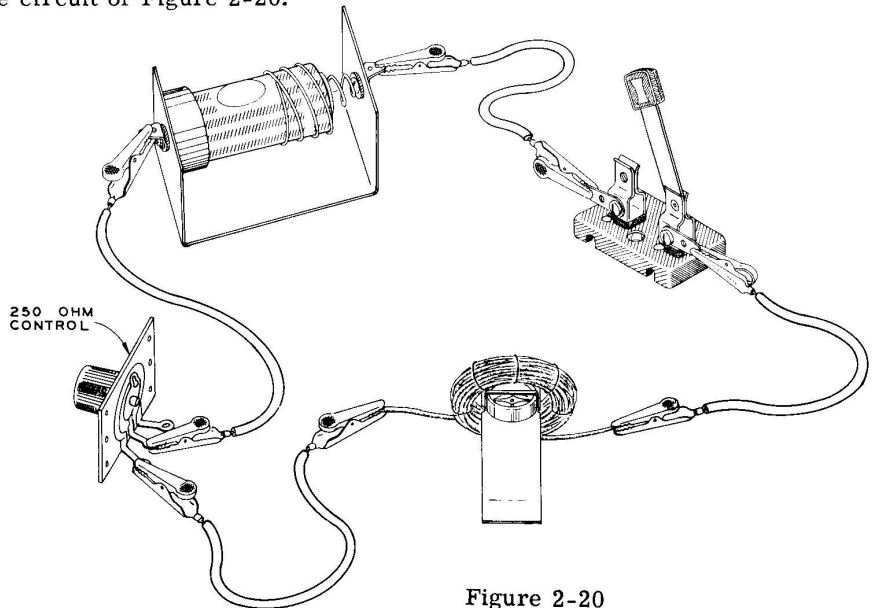

Figure 2-20

Close the switch and rotate the 250 Ω control and observe the compass needle. Note that when the control is set for maximum resistance, the needle rotates very little from its rest position. As the resistance is decreased, the needle rotates more and more, indicating that the magnetic field is getting stronger and stronger. Be sure to disconnect the circuit when you are through observing the deflections of the needle. Unwind the coil so that this wire can be used in circuit hookups.

This demonstration shows that the greater the rate of flow of current, the stronger the magnetic field and hence the greater the deflection of the compass needle. It so happens that the magnetic field is directly proportional to the rate of flow of current; in other words, if we double the rate of flow of current the strength of the magnetic field is doubled.

The compass needle, then, is indirectly indicating the rate of flow of current through the coil. We say indirectly for we are depending on the strength of the magnetic field created by the current to cause the needle to indicate as it does.

The EK-1 meter movement is constructed essentially the same way as the physical setup of your compass and coil, for the meter movement is a moving magnet mounted inside a coil of wire. The physical setup basically looks like Figure 2-21.

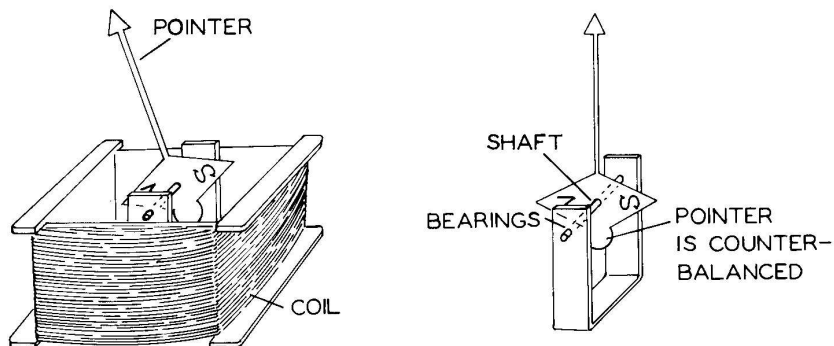

Figure 2-21

A pointer is attached to the moving magnet so that the indications of the moving magnet can be observed more readily. The pointer must be counterbalanced so that the earth's gravity will not cause the pointer to rotate. The only force, then, that will cause the pointer to rotate is the magnetic field created by the current that flows through the coil.

Suppose electrons did flow through the coil as pictured in Figure 2-21, in such a way that the needle would rotate clockwise. Upon stopping the flow of current through the coil, we would observe that the needle does not return to its former position since there is no force present to move the needle back to the original position. In the case of the compass needle, the earth's magnetic field returned the needle to its original position. The EK-1 Meter cannot use the earth's magnetic field for this purpose as moving the meter at different angles would change the effectiveness of the earth's magnetic field. The meter is so constructed that the earth's magnetic field has little or no effect upon the moving magnet.

Another fault of the meter as pictured in Figure 2-21 is that any current capable of starting the needle moving would rotate it all the way across until it was stopped by the edge of the coil. Therefore, it would be impossible to detect the difference between weak and strong currents unless the speed of rotation of the needle could be observed, since the stronger the current the faster the needle would rotate. To overcome these problems, a permanent magnet is placed on the back of the coil, as in Figure 2-22, in such a way that the south pole of the permanent magnet is behind the north pole of the compass needle and the north pole of the permanent magnet is behind the south pole of the compass needle.

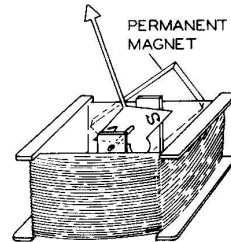

Figure 2-22

The magnetic field of the fixed magnet works with the magnetic field of the compass needle in such a way that the compass needle is forced to rest opposite the fixed magnet. If we were to rotate the pointer clockwise, Figure 2-23, and then release the pointer, it would return to its original position. Also, the greater the rotation away from its rest position, the greater must the force be to hold the needle away from its rest position.

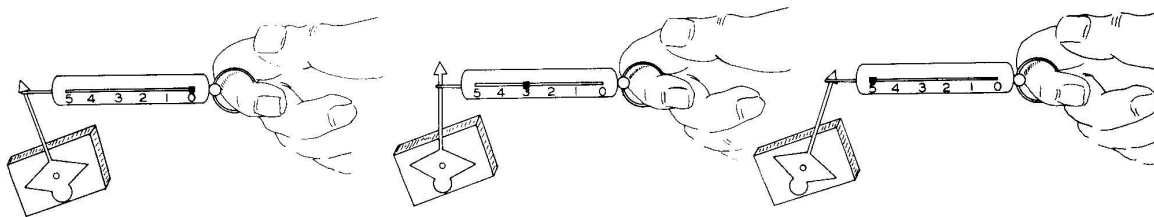

Figure 2-23

Having placed a permanent magnet on the outside of the coil has solved the two problems previously mentioned, for now the needle will always return to its rest position and the stronger the current through the coil, the greater the rotation of the pointer. Up to this point, all discussion assumed the rest position of the pointer to be at the left side of the coil, and current flowing through the coil in a direction such that the pointer would move from left to right. This is the usual case, and to make sure that the meter is connected properly to the electrical circuit, the terminals at the back of the meter are marked plus (+) and minus (-). If the terminals of the meter were connected in reverse, the needle would rotate in the wrong direction.

Most devices that will detect current flowing through a wire, can be made to tell us how much current is flowing, if we can calibrate it with a standard. To illustrate the idea of calibrating measuring equipment, imagine making a scale for use in weighing various objects. We need a screen door spring, wood, paper, wire, hook-eye, and metal pointer and pan cut from tin cans.

Figure 2-24 illustrates a typical homemade scale.

With everything in place, the spring will be partially stretched due to the weight of the pan and pointer. Since the pan and pointer will never stretch the spring any farther, generally speaking, we can mark the paper "0" in line with the pointer. Then, using some other scale in the house, such as the bathroom scale, as a standard, we can put various objects on the bathroom scale until it reads "1 lb." Placing these same objects on the pan of our homemade scale will then cause the spring to stretch more, and the pointer to move down a certain amount. Since 1 pound of weight causes the pointer to come to rest at a new location on the paper, we can mark this new location "1". If we continue placing objects on the bathroom scale until they equal "2 lbs.", "3 lbs.", etc., and then place them in the pan and mark the paper in line with the pointer "2", "3", etc., we will end up with a weighing device about as accurate as the bathroom scale, since this is the reference, or standard, used in calibrating the paper dial on the homemade scale.

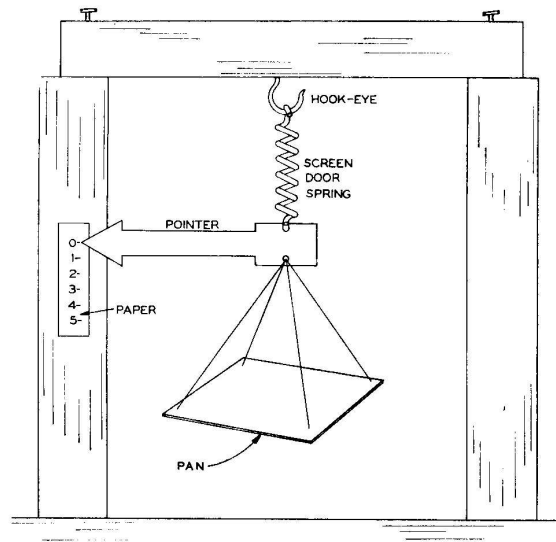

Figure 2-24

To illustrate further the method of calibrating, suppose you devised some method of measuring time rate of water flow for the machine in Figure 2-25. By connecting your instrument beside the commercial meter, and using this as a reference or standard, you could regulate the valve causing the commercial meter to register different time rates of water flow, and where the indicator of your meter came to rest, you would mark these points appropriately, thereby calibrating your water meter.

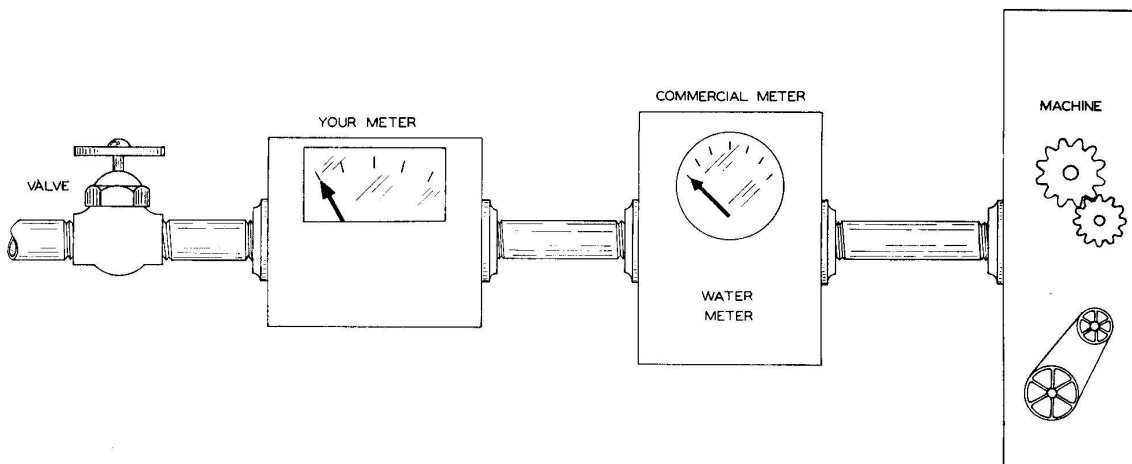

Figure 2-25

By affixing an appropriate piece of cardboard behind the pointer of the meter in Figure 2-21 we can calibrate the meter, using another meter as a standard. Observe Figure 2-26 and note the similarity to Figure 2-25.

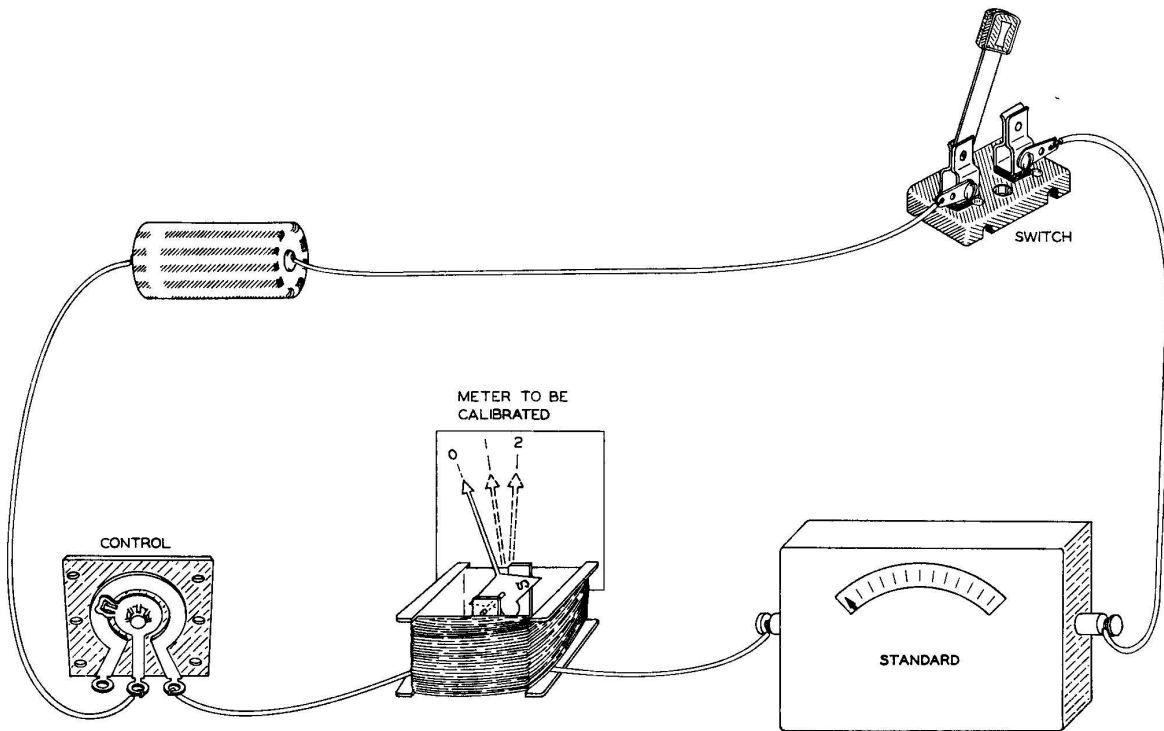

Figure 2-26

Here again the calibrating procedure is about the same. The switch is closed and the control is rotated so that the standard meter can indicate appropriate rates of flow of current. The cardboard is then marked accordingly.

The commercial method of calibrating an electrical meter.

Meters used for general purpose work, that is, work that does not require extreme accuracy, cannot be individually calibrated if the cost of the meter is to be appealing to industry.

Indications of ten like meters are taken and averaged and from this information a "common" meter face is printed.

For example, to calibrate the dial of the EK-1 Meter, one manufacturer connects ten of these meters in series with a very accurate standard, Figure 2-27, and an electrical source that can be adjusted to give any current desired.

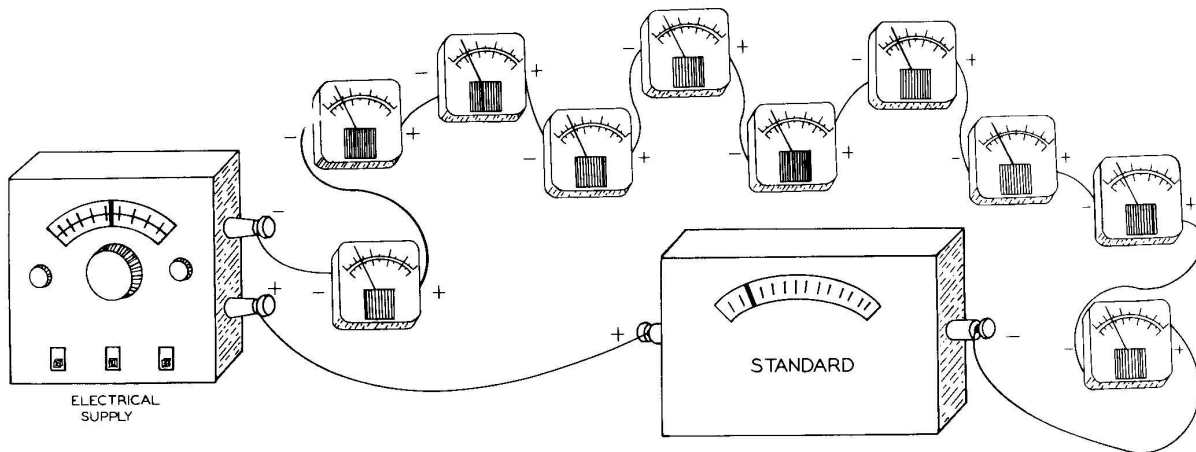

Figure 2-27

The EK-1 Meter reads full scale when one thousandth, or .001, ampere of current flows through the coil. One thousandth of an ampere is called a "milliampere." This type of meter is called a "0 to 1 milliampere meter" or more simply a "milliammeter", since it takes 1 milliampere of current to rotate the pointer to the end of the scale.

Scales marked in degrees are fastened behind the pointers on these meters. The operator turns the control on the electrical source until the standard meter indicates one tenth of a milliampere (.0001 ampere). Each meter is read and the number of degrees recorded and averaged by adding up the ten readings and dividing by ten. Suppose the ten readings were as follows: 5.7°, 5.7°, 5.8°, 5.7°, 5.9°, 5.9°, 5.8°, 5.9°, 5.7°, and 5.9°, which equals 58°. Dividing 58° by ten gives 5.8° and represents one tenth of a milliampere. The current control is then advanced until two tenths of a milliampere (.0002 ampere) is recorded on the standard meter, and readings are again taken from the ten meters and averaged. This procedure continues until the standard meter has indicated currents of .3, .4, .5, .6, .7, .8, .9 and 1 milliampere, at which time all meters are indicating full scale.

Suppose the average degree readings from the ten meters, and current readings from the standard meter, are as follows:

Averaged Degree Readings	0	5.8	11	18	25.1	33.2	41.4	50	57.9	64.2	71
Current (milliamperes)	0	0.1	0.2	0.3	0.4	0.5	0.6	0.7	0.8	0.9	1.0

A drawing four times larger than the actual meter face is made by laying off the degree marks as indicated in the box, and then inserting the proper numbers representing the various amounts of current. From this enlarged drawing, Figure 2-28, meter faces are printed.

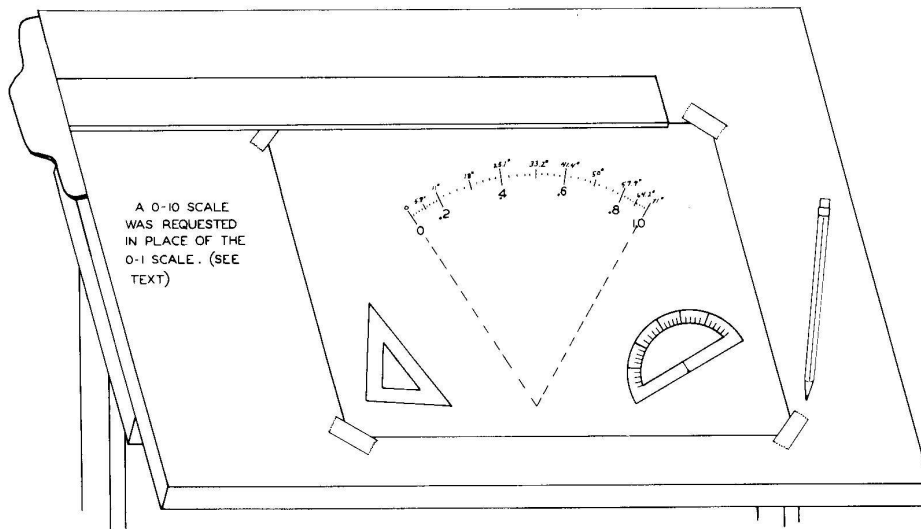

Figure 2-28

By using other components, the meter for EK-1 is made to indicate rate of flow of current up to 500 milliamperes (1/2 ampere), and so the scale 0-10 was requested in place of 0-1. When reading 1 milliampere, mentally divide the 0-10 scale by ten. For example, 8 becomes .8 milliampere. If we wish to make readings between 0 and 100 milliamperes, we simply multiply the 0-10 scale by ten. For example, 6 becomes 60. More will be said about scale reading when the time comes to make actual readings with the meter.

You might have wondered why a certain manufacturer uses ten meters rather than one meter, in series with the standard, to obtain the degrees of deflection for the "common" meter face. The reason is that no two meters will indicate exactly the same, because of slight physical differences. Two coils can never be wound exactly the same, two permanent magnets will never contain exactly the same amount of magnetism, and no two sets of bearings will offer the same resistance to the rotating shafts.

The EK-1 Meter face must contain markings that can be used with any EK-1 Meter that comes from the assembly line. If a meter indicating a little low or a little high had been used to furnish information needed to print the meter face, many of the meters would indicate greater errors than could be tolerated.

The meter for EK-1 is accurate to within 5% of full scale. On the 0-10 scale we take 5% of 10, which equals .5. This tells us that the needle will indicate up to, but no more than, .5 higher or .5 lower than the actual reading. For example, suppose the true current in the circuit is 6 milliamperes. The needle could indicate anywhere between 5.5 and 6.5 milliamperes, as shown in Figure 2-29. In other words, on the 0-10 milliampere scale the needle will be accurate to within .5, or 1/2, of a milliampere anywhere along the scale.

The most commonly used meters are accurate to within 2%, but cost much more than the 5% meter movement. The 5% movement is not as delicate as the usual 2% movement, and therefore, cannot be damaged as readily when an excess of current flows through the meter movement.

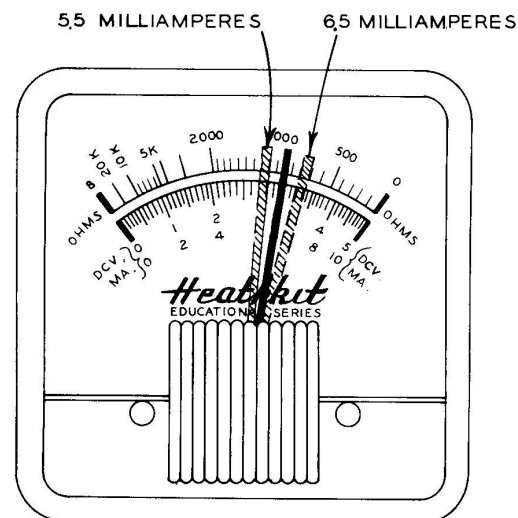

Figure 2-29

Now that we understand how the EK-1 meter was calibrated, we will put it to work.

Measuring current flowing through a series circuit.

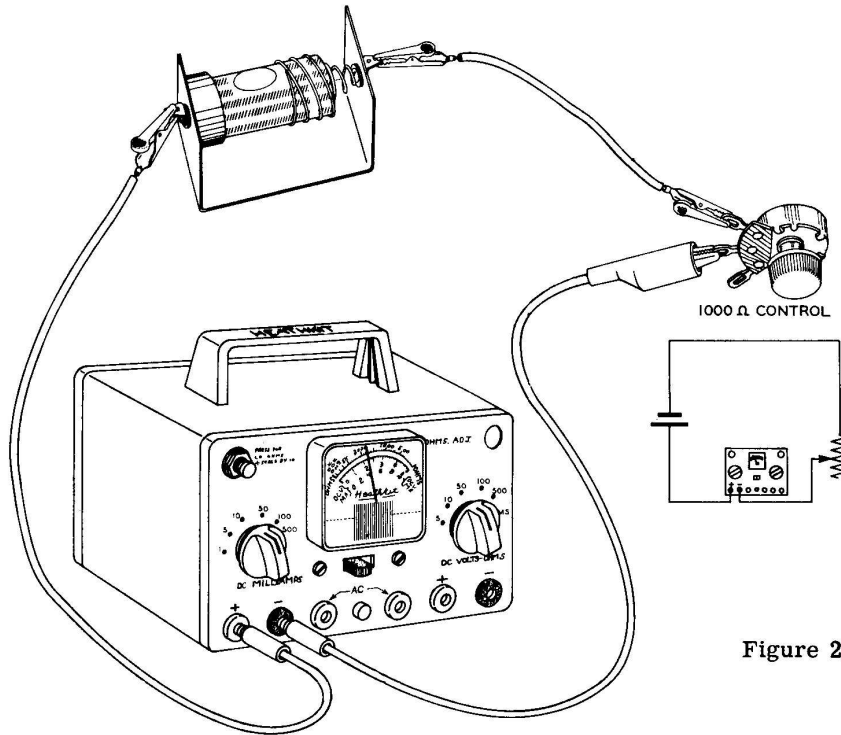
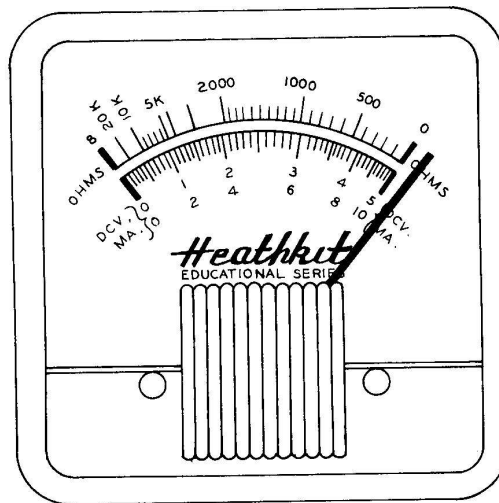

Figure 2-30

If the control, Figure 2-30, happens to be set such that the resistance it presents to the circuit is minimum, the needle in the meter will pin itself to the right side of the dial, Figure 2-31. Under ordinary circumstances the meter would burn out, however, the EK-1 Meter has such a high resistance that it cannot be burned out while doing any of the experiments discussed in this book. You can also expect this condition to occur when performing some of the other experiments. Now construct the circuit of Figure 2-30.

Figure 2-31



Install one of the small black knobs on the shaft of the control and rotate the knob until the pointer indicates full scale, Figure 2-32.

Figure 2-32

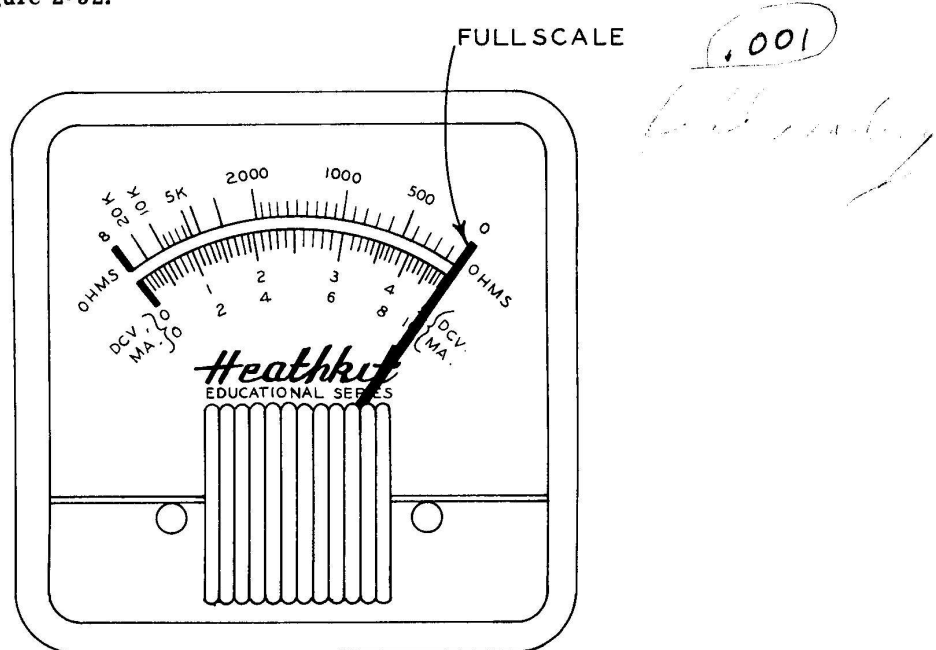

With the pointer at full scale position, the meter is indicating that 1 milliampere of current is flowing from the cell, through the 1,000 Ω control, and back to the cell. To read 1 milliampere on the meter, observe the 0-10 scale which is directly above the word "Heathkit" and mentally divide by 10. For example, the pointer indication of $10 \div 10 = 1$, and this represents 1 milliampere.

Now rotate the control until the pointer is halfway between 8 and 10, Figure 2-33.

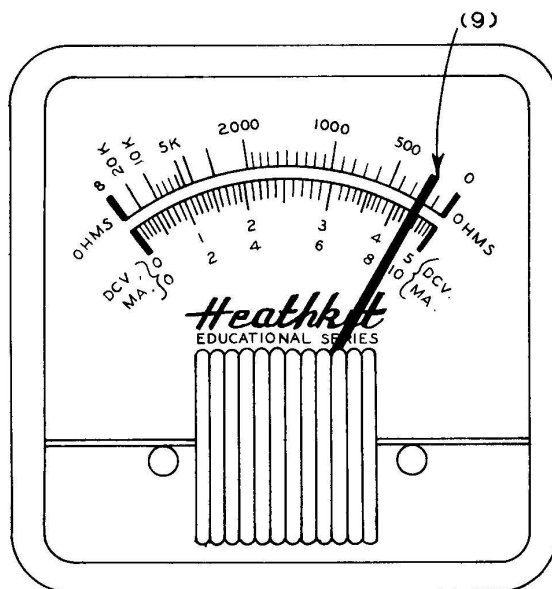

Figure 2-33

The pointer now indicates 9 on the meter face, and dividing 9 by 10 gives us .9 or 9/10 of a milliampere. IT MUST BE REMEMBERED THAT NO MATTER HOW THE METER IS CONNECTED IN THE CIRCUIT, OR WHAT IS PRINTED ON THE METER FACE, THE EK-1 METER REQUIRES ONLY 1 MILLIAMPERE OF CURRENT TO INDICATE FULL SCALE.

Consider the preceding circuit, Figure 2-30, in schematic form, Figure 2-34. The wiggly line and arrow form the symbol for a variable resistor.

Figure 2-34 is a d-c series circuit because the source of electrical energy will deliver a continuous flow of current, the load is the variable resistor, and the wires are connected such that the current flows through the circuit from one place to the next place in succession.

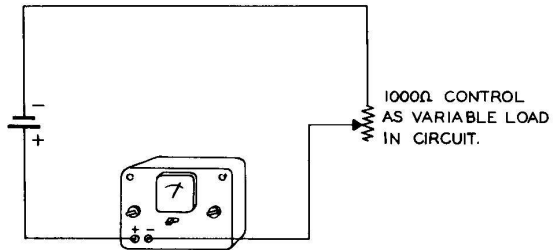

Figure 2-34

The current in all parts of a series circuit is the same. The current flowing away from the load, as measured in Figure 2-30, must equal the current flowing to the load. To prove this first readjust the control, if necessary, so that the meter indicates .9 milliamperes and then reconnect the milliammeter so that it will measure the current flowing to the load, Figure 2-35.

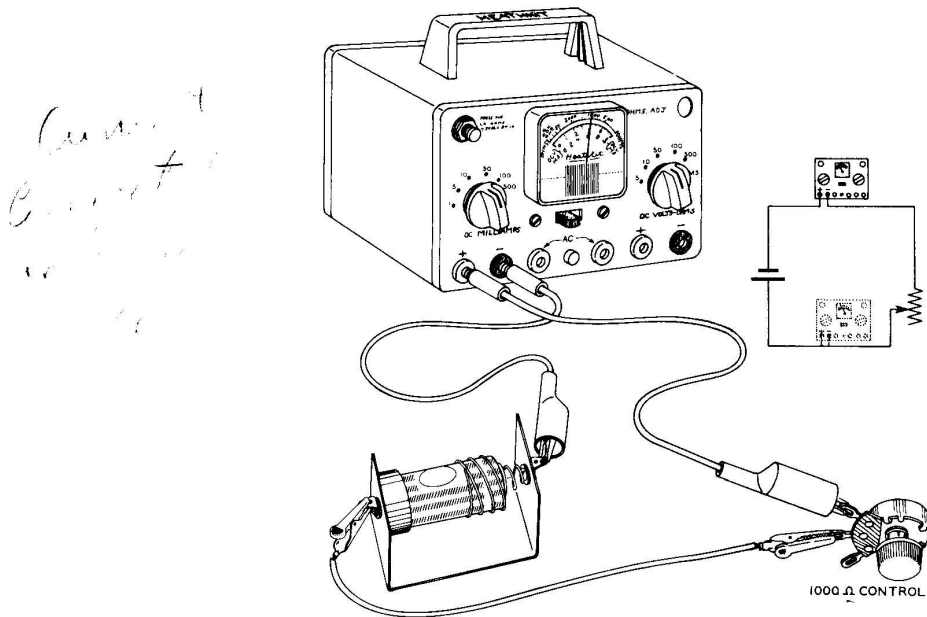

Figure 2-35

We can rightly conclude from this demonstration that it makes no difference where in the series circuit the milliammeter is connected as it will always indicate the same rate of flow of current. Disconnect one test lead to open this circuit temporarily.

OHM'S LAW

As was previously mentioned, the relationship between voltage, current and resistance was first given by George S. Ohm. This relationship is known as Ohm's Law and is stated as follows: The resistance of a circuit, in ohms, is equal to the voltage across this resistance, in volts, divided by the current flowing through this resistance, in amperes. Ohm's Law, mathematically stated is:

$$1 \text{ ohm} = \frac{1 \text{ volt}}{1 \text{ ampere}} \longrightarrow \frac{1 \text{ volt}}{1 \text{ ampere}} = 1 \text{ ohm}$$

Using letters -- $R = \frac{V}{I}$

Where R = resistance in ohms

V = electrical pressure in volts

I = current in amperes

Observe Figure 2-36

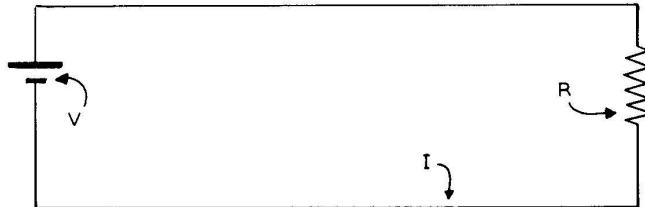

Figure 2-36

The current flowing through a circuit depends on the amount of electrical pressure (voltage) and the amount of resistance (ohms) present in the circuit. The only way that current flowing around a circuit can be made to increase or decrease in amount is to increase or decrease the voltage, or increase or decrease the resistance of the circuit. Since the circuit of Figure 2-37 contains a fixed resistance of 1 ohm, the only way that we can increase the current is by increasing the voltage.

The meter indicates one ampere when connected to (A) and two amperes when connected to (B).

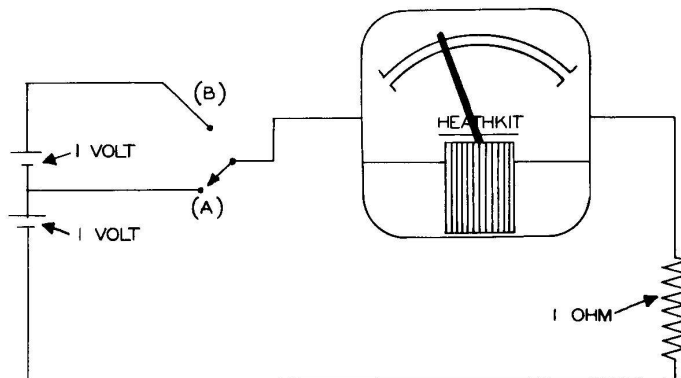

Figure 2-37

With a fixed voltage source in Figure 2-38 of 1 volt, the only way the current can be increased is to decrease the resistance.

The meter indicates 1 ampere when connected to (A) and 2 amperes when connected to (B).

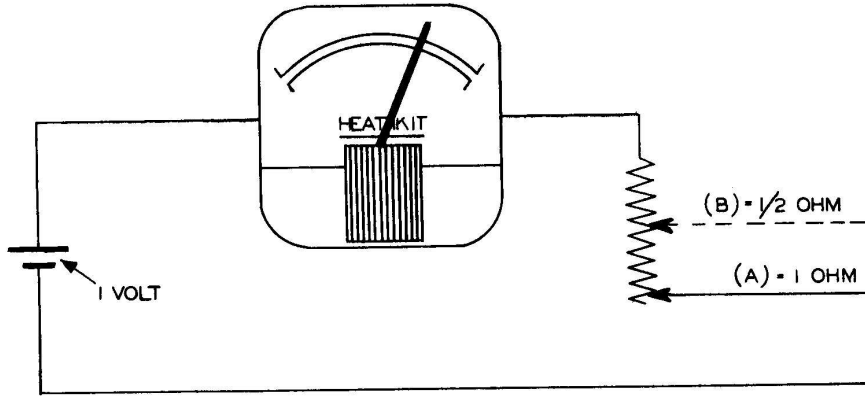

Figure 2-38

Why is it that Ohm's Law must be in the form of $R = \frac{V}{I}$ rather than $R = V + I$, or $R = VI$ or $R = \frac{I}{V}$?

To answer this question we will mathematically test these formulas against the two circuit conditions of Figures 2-37 and 2-38.

The correct formula for Ohm's Law will be: Case (1) $(R = \frac{V}{I})$

and the other assumed formulas will be: Case (2) $(R = V + I)$

Case (3) $(R = VI)$

and Case (4) $(R = \frac{I}{V})$

Both meters indicate 1 ampere with connection (A) and 2 amperes with connection (B).

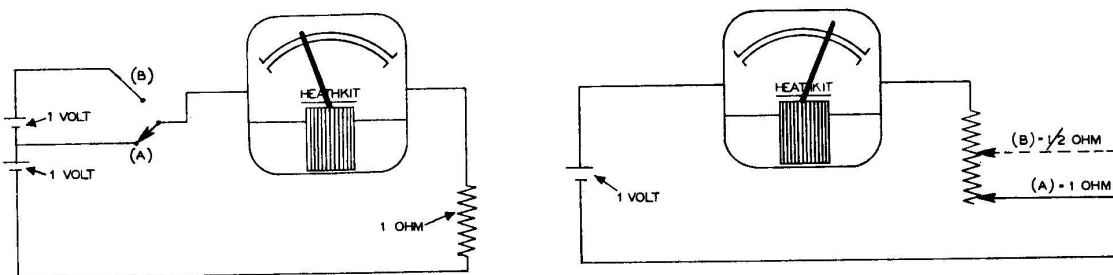

Figure 2-39

Case 1	$R = \frac{V}{I}$		$R = \frac{V}{I}$
Ammeter Connection (A)	$1 \text{ ohm} = \frac{1 \text{ volt}}{1 \text{ ampere}}$ $1 = \frac{1}{1}$ $1 = 1$	Resistance Connection (A)	$1 \text{ ohm} = \frac{1 \text{ volt}}{1 \text{ ampere}}$ $1 = \frac{1}{1}$ $1 = 1$
Ammeter Connection (B)	$1 \text{ ohm} = \frac{2 \text{ volts}}{2 \text{ amperes}}$ $1 = \frac{2}{2} \text{ or } 1 = 1$	Resistance Connection (B)	$1/2 \text{ ohm} = \frac{1 \text{ volt}}{2 \text{ amperes}}$ $1/2 = 1/2$

We see that all four conditions agree.

Case 2	$R = V + I$		$R = V + I$
Ammeter Connection (A)	$1 \text{ ohm} = 1 \text{ volt} + 1 \text{ ampere}$ $1 = 1 + 1$ $1 \neq 2$	Resistance Connection (A)	$1 \text{ ohm} = 1 \text{ volt} + 1 \text{ ampere}$ $1 = 1 + 1$ $1 \neq 2$
\neq means: is <u>not</u> equal to			
Ammeter Connection (B)	$1 \text{ ohm} = 2 \text{ volts} + 2 \text{ amperes}$ $1 = 2 + 2$ $1 \neq 4$	Resistance Connection (B)	$1/2 \text{ ohm} = 1 \text{ volt} + 2 \text{ amperes}$ $1/2 = 1 + 2$ $1/2 \neq 3$

We see that none of the four conditions agree.

Case 3	$R = VI$		$R = VI$
Ammeter Connection (A)	1 ohm = 1 volt x 1 ampere 1 = 1 x 1 1 = 1	Resistance Connection (A)	1 ohm = 1 volt x 1 ampere 1 = 1 x 1 1 = 1
Ammeter Connection (B)	1 ohm = 2 volts x 2 amperes 1 = 2 x 2 1 ≠ 4	Resistance Connection (B)	1/2 ohm = 1 volt x 2 amperes 1/2 = 1 x 2 1/2 ≠ 2

We see that two of the conditions do not agree.

Case 4	$R = \frac{I}{V}$		$R = \frac{I}{V}$
Ammeter Connection (A)	1 ohm = $\frac{1 \text{ ampere}}{1 \text{ volt}}$ 1 = $\frac{1}{1}$ 1 = 1	Resistance Connection (A)	1 ohm = $\frac{1 \text{ ampere}}{1 \text{ volt}}$ 1 = $\frac{1}{1}$ 1 = 1
Ammeter Connection (B)	1 ohm = $\frac{2 \text{ amperes}}{2 \text{ volts}}$ 1 = $\frac{2}{2}$ 1 = 1	Resistance Connection (B)	1/2 ohm = $\frac{2 \text{ amperes}}{1 \text{ volt}}$ 1/2 = $\frac{2}{1}$ 1/2 ≠ 2

We see that one condition does not agree.

It should be concluded from the preceding discussion that the formula in Case 1 is the only correct formula for the relationship between resistance, voltage and current as this is the only situation in which all four conditions agree.

When the entire EK-1 instrument has been constructed we will be able to verify "Ohm's Law".

If we know the voltage and current, it is a simple matter to calculate the resistance. Try your skill with mathematics on the following problems.

Problem (1)

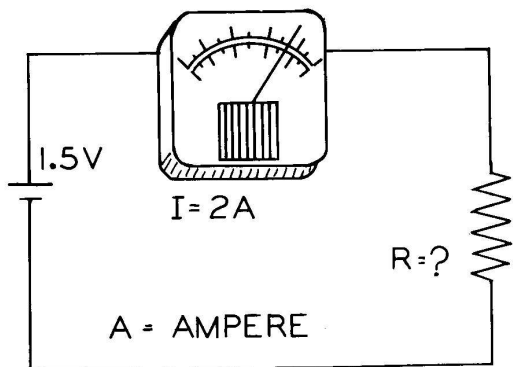

Problem (2)

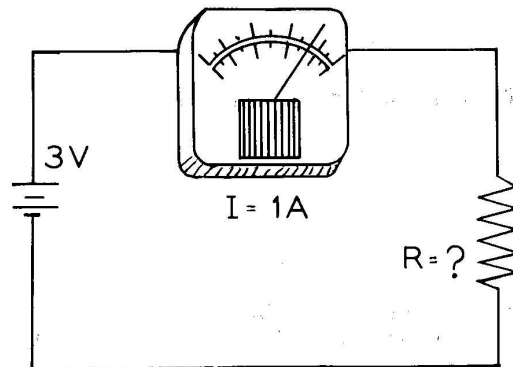

Solution: $R = \frac{V}{I} = \frac{1.5}{2} = ? \text{ ohms}$

Problem (3)

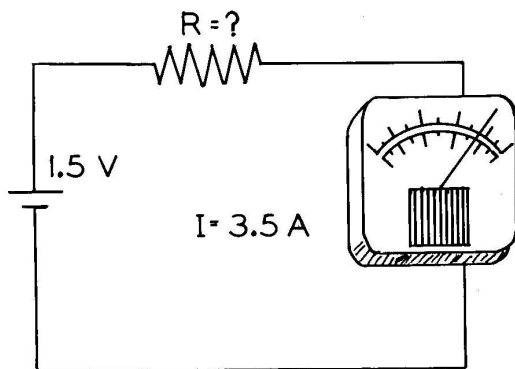

Problem (4)

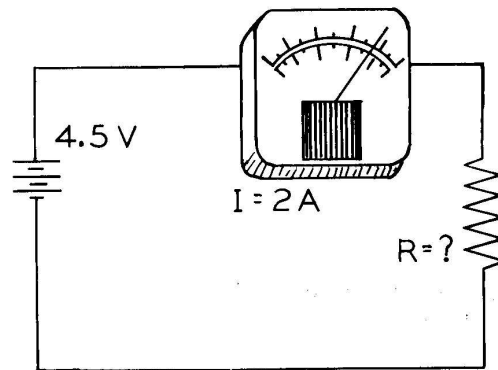

- Answers: (1) .75 or 3/4 ohm (2) 3 ohms
 (3) .43 ohm (4) 2.25 ohms

THE THREE FORMS OF OHM'S LAW

When voltage and resistance are known, Ohm's Law takes the form:

$$I = \frac{V}{R} \quad (1)$$

Read: Current = Voltage \div Resistance

When resistance and current are known, Ohm's Law takes the form:

$$V = IR \quad (2)$$

Read: Voltage = Current \times Resistance

The original form listed here for reference when we know voltage and current is:

$$R = \frac{V}{I} \quad (3)$$

Read: Resistance = Voltage \div Current

An easy method for finding the relationships between V, I and R is to draw a circle and divide it as shown in Figure 2-40A and then insert V in the top space, I and R in the bottom spaces, Figure 2-40B.

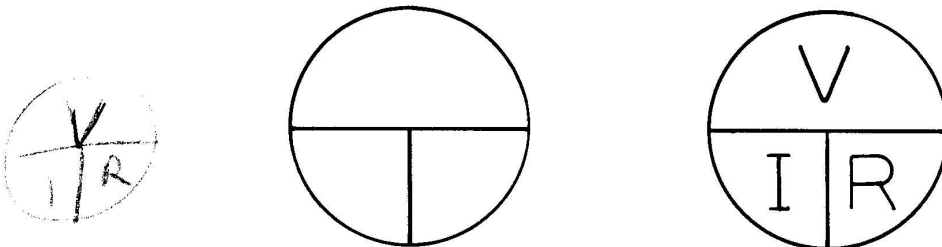

A

Figure 2-40

B

Cover the unknown with your thumb and perform the indicated operation with the remaining symbols.

For example, if we wish to recall the formula for finding current we cover I and observe:

$$\frac{V}{R} \text{ thus } I = \frac{V}{R}$$

If we seek the formula for finding resistance, we cover R and observe:

$$\frac{V}{I} \text{ thus } R = \frac{V}{I}$$

Likewise, if we cover V we see IR together, thus

$$V = IR$$

To understand better how Ohm's Law can assume three forms, let us relate formula #2 ($V = IR$) to the formula for the area of a rectangle ($A = LW$), with which you are probably more familiar.

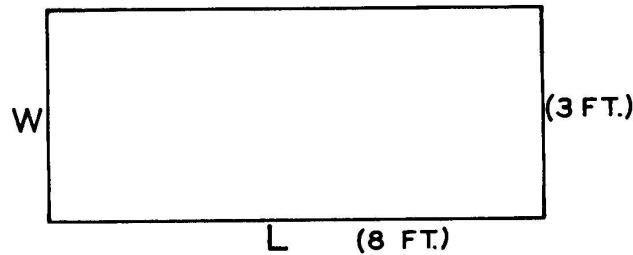

You will recall that the area (A) of a rectangle is equal to the length (L) times the width (W). For the above rectangle, the arithmetic work would look as follows:

$$\begin{aligned} A &= LW \\ A &= 8 \text{ ft.} \times 3 \text{ ft.} \quad (1) \\ A &= 24 \text{ square ft.} \end{aligned}$$

Here 8 ft. was substituted for the letter (L), which represents the length of all rectangles and 3 ft. was substituted for the letter (W), which represents the width of all rectangles. Now, suppose the area of 24 square ft. and the length, 8 ft., are known. How is the width found? If the area, 24 square ft., is divided by the length, 8 ft., we obtain 3 ft. (the width), or

$$\frac{24}{8} = 3$$

Replacing $\frac{24}{8} = 3$ by letters, we have:

$$\frac{A}{L} = W \text{ or } W = \frac{A}{L} \quad (2)$$

If the area, 24 square ft., and the width, 3 ft., are known, then how do we find the length? The length is found by dividing the area, 24 square ft., by the width, 3 ft., or

$$\frac{24}{3} = 8$$

Replacing the numbers by letters, we have

$$\frac{A}{W} = L \text{ or } L = \frac{A}{W} \quad (3)$$

The three forms for the area of a rectangle are then

$$A = LW \quad (1)$$

$$W = \frac{A}{L} \quad (2)$$

$$L = \frac{A}{W} \quad (3)$$

If V is substituted in place of A , I for L , and R for W , we have the three forms of Ohm's Law.

$$V = IR$$

$$R = \frac{V}{I}$$

$$I = \frac{V}{R}$$

When we have a formula such as $A = LW$, the letter A is called the subject of the formula, for the area is what we are looking for. However, in equation 2,

$$W = \frac{A}{L}$$

W becomes the subject of the formula as now we are looking for the width of the rectangle, rather than the area. This is called "changing the subject of the formula." What is the subject of the formula in

$$L = \frac{A}{W} \quad I = \frac{V}{R} \quad R = \frac{V}{I} \quad V = IR?$$

The answers are respectively L , I , R and V .

CHANGING THE SUBJECT OF A FORMULA BY ALGEBRA

A statement usually accepted as true is called an "axiom". An "axiom" cannot be theoretically proven, and therefore, exists in the minds of men as a self-evident truth. Two examples of axioms are: (1) "The whole of a quantity is greater than any of its parts," and (2) "The whole of a quantity is equal to the sum of its parts." There are four equation axioms that must be considered briefly, as they form the foundation for algebra.

Addition Axiom: The same number may be added to both members of an equation without destroying the equality.

Consider the equation	$4 = 4$
Add (1) to both members	$1 + 4 = 4 + 1$
	or $5 = 5$

The equality has not been changed.

Subtraction Axiom: The same number may be subtracted from both members of an equation without destroying the equality.

Consider the equation	$6 = 6$
Subtract (3) from both members	$6 - 3 = 6 - 3$
	or $3 = 3$

The equality has not been changed.

Multiplication Axiom: Both members of an equation may be multiplied by the same number without destroying the equality.

Consider the equation	$8 = 8$
Multiply both members by (2)	$2 \times 8 = 8 \times 2$
	or $16 = 16$

The equality has not been changed.

Division Axiom: Both members of an equation may be divided by the same number, except zero, without destroying the equality.

Consider the equation	$10 = 10$
Divide both members by (5)	$\frac{10}{5} = \frac{10}{5}$
	or $2 = 2$

The equality has not been changed.

It is this last axiom that will be used most often throughout the rest of this book. Consider again the formula for the area of a rectangle, "A = LW" and with algebra change the subject from "A" to "L".

Solution:

$$A = LW$$

Divide both members by (W)

$$\frac{A}{W} = \frac{L\cancel{W}}{\cancel{W}}$$

Then

$$\frac{A}{W} = L \text{ or } L = \frac{A}{W}$$

Now, consider the formula for voltage when current and resistance are known, and change the subject of the formula from "V" to "I" and "R", respectively.

Solution:

$$V = IR$$

Divide both sides by (R)

$$\frac{V}{R} = \frac{\cancel{I}R}{\cancel{R}}$$

Then

$$\frac{V}{R} = I \text{ or } I = \frac{V}{R}$$

Solution:

$$V = IR$$

Divide both sides by (I)

$$\frac{V}{I} = \frac{\cancel{I}R}{\cancel{I}}$$

Then

$$\frac{V}{I} = R \text{ or } R = \frac{V}{I}$$

If you would remember Ohm's Law as "V = IR," the other two forms can quickly be derived by using the division axiom. It is suggested that you acquire skill in changing the subject of the formulas "V = IR" and "A = LW," using the division axiom.

**EXTENDING THE CURRENT RANGE OF THE
0-1 MILLIAMPERE METER**

In Figure 2-41, the variable resistance load is adjusted so that 2 milliamperes are flowing around the circuit.

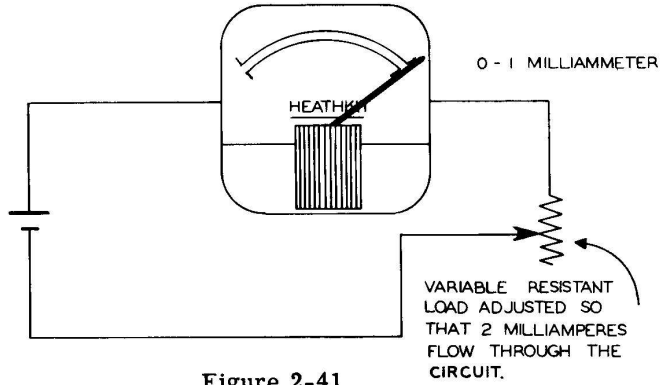

Figure 2-41

The pointer in the meter will be pinned to the right side of the meter for when more than one milliampere flows through the meter, the pointer continues to move beyond full scale in a clockwise direction until stopped by some part of the meter.

This illustrates that unless some method is provided, the 0-1 milliammeter can never be used to indicate currents greater than 1 milliampere. The method used to extend the range of the meter is to bypass a certain portion of the current around the meter.

Construct Figure 2-42.

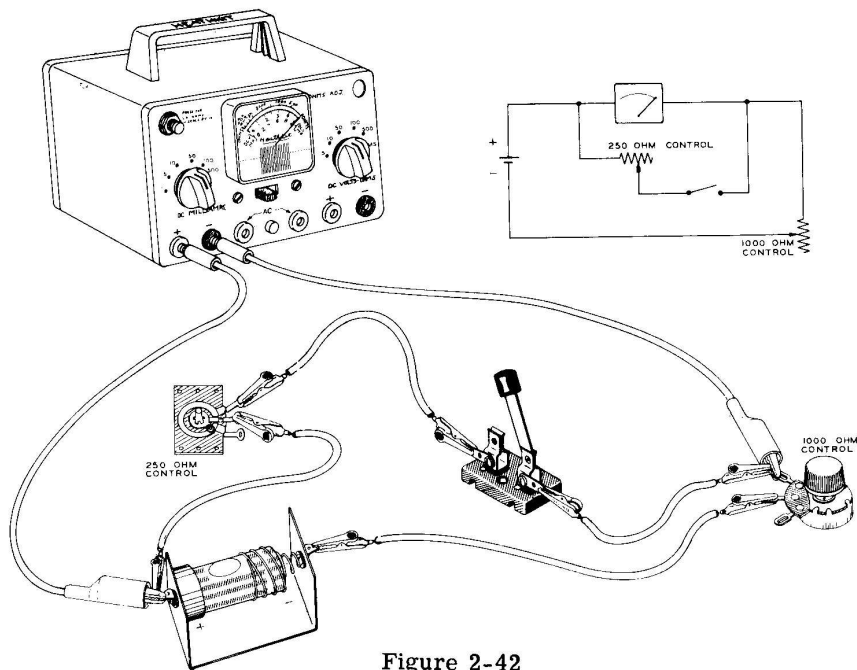

Figure 2-42

With the switch open, adjust the 1000 ohm control so that the meter indicates 1 milliampere. Rotate the 250 ohm control so that it presents maximum resistance to the circuit. Close the switch and observe the meter. The meter indicates that less than half a milliampere is now flowing through it. By closing the switch, the current divides, part flowing through the 250 ohm control and the other part flowing through the meter. This is indicated with arrows in Figure 2-43.

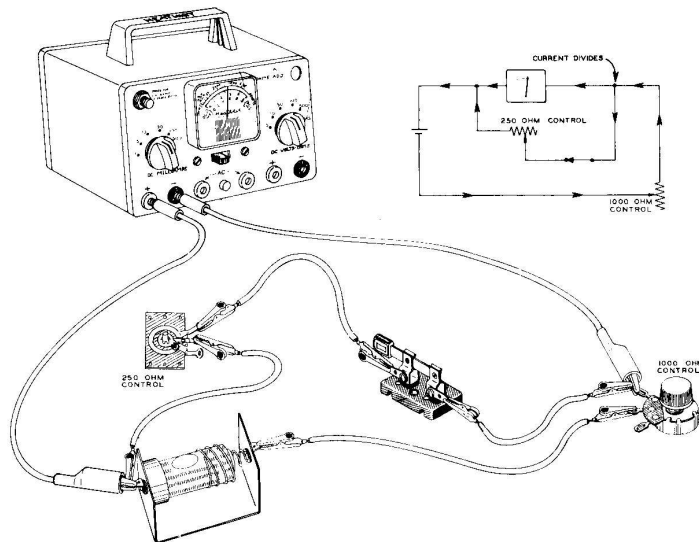

Figure 2-43

The 250 ohm control is said to be shunting current around the meter. It is for this reason that a resistor connected in parallel across a meter is called a shunt. Rotate the 250 ohm control and observe its effect on the meter.

Extending the 0-1 Milliampmeter to Indicate 0-10 Milliamperes.

Imagine that the variable resistance load is adjusted so that 10 milliamperes of current flow through the circuit. If nothing was done to the 0-1 milliammeter circuit, the pointer as discussed before, would be pinned to the right side of the meter and the excess of current could burn out the meter. By connecting resistance R_x (pronounced R sub x) across the meter terminals, we cause some of the current to bypass the meter, thus reducing the amount of current flowing through the meter. If resistance R_x is of a certain value, 9 of the 10 milliamperes of current will flow through the resistance, leaving 1 milliampere to flow through the movement, as shown in Figure 2-44. Milliampere is abbreviated ma.

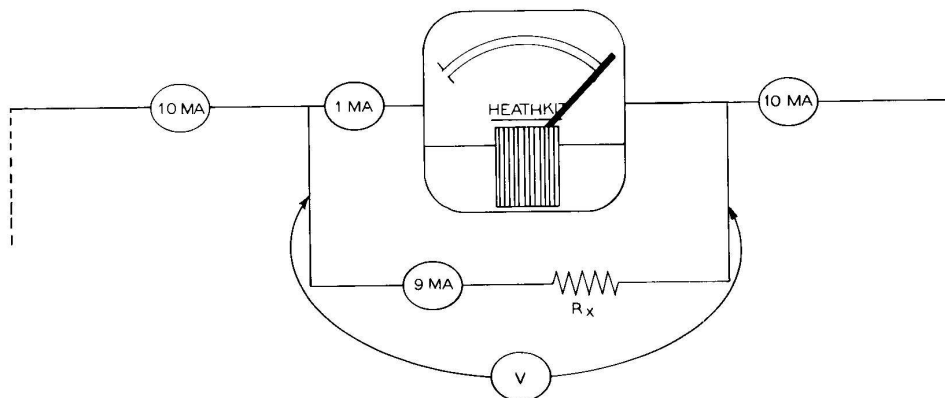

Figure 2-44

The meter and shunt resistor are connected in parallel, therefore, and voltage (V) across the meter is the same as that across the shunt. The meter, as specified by the manufacturer, has 1000 ohms of resistance. From Ohm's Law, the voltage across the meter is equal to the current through the meter times the resistance of the meter. When using Ohm's Law, the current must always be expressed in amperes and, therefore, 1 milliamperere equals .001 ampere. The voltage is calculated as follows:

$$V = IR$$

$$V = .001 \text{ ampere} \times 1000 \text{ ohms}$$

$$V = 1 \text{ volt}$$

Since the voltage across R_x is equal to the voltage across the meter (1 volt), and 9 of the 10 milliamperes are to flow through this resistance, we can now find R_x by Ohm's Law as follows:

$$R_x = \frac{V}{I} = \frac{1 \text{ volt}}{.009 \text{ ampere}}$$

$$R_x = 111 \text{ ohms}$$

Now that we know the resistance necessary to shunt 9 milliamperes around the meter when a current of 10 milliamperes is flowing through the circuit (the meter thus indicating full scale) let us investigate the condition when the pointer is indicating half-scale (1/2 milliamperere) shunted by the 111 ohm resistor, as in Figure 2-45.

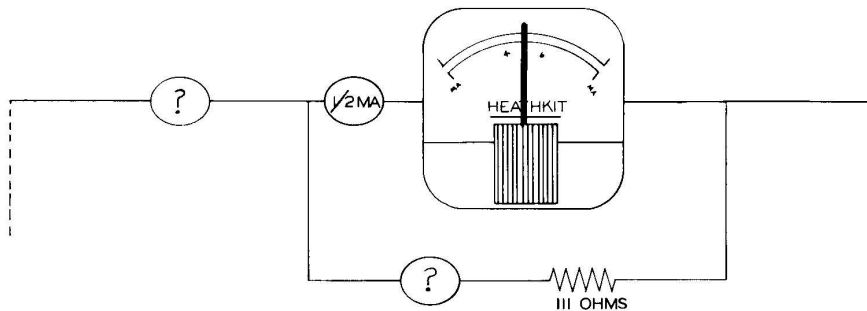

Figure 2-45

Again, the voltage across the meter can be calculated by Ohm's Law as follows:

$$V = IR = .0005 \text{ ampere} \times 1000 \text{ ohms}$$

$$V = 0.5 \text{ volt}$$

Since the voltage across the meter is the same as that across the 111 ohm resistor, the current flowing through the resistance is

$$I = \frac{V}{R} = \frac{0.5 \text{ volt}}{111 \text{ ohms}} = .0045 \text{ ampere or } 4.5 \text{ milliamperes}$$

If the meter indicates .5 milliamperere flowing through it, and we calculated 4.5 milliamperes flowing through the 111 ohm resistance, then the total current flowing around the circuit equals .5 plus

4.5 milliamperes, or 5 milliamperes. THIS SHOWS THAT THE ACTUAL CURRENT FLOWING THROUGH THE CIRCUIT (5 MILLIAMPERES) EQUALS TEN TIMES THE CURRENT FLOWING THROUGH THE METER (.5 MILLIAMPERE). We could calculate the total current flowing through the circuit for each pointer setting from 0 to 1 milliampere as we just have for .5 milliampere, AND EACH TIME THE TOTAL CURRENT WOULD EQUAL TEN TIMES THE ACTUAL CURRENT FLOWING THROUGH THE METER. By marking the meter scale with numbers from 1 through 10, we have what is known as a "direct reading scale" when the meter is shunted with 111 ohms. A 110 ohm resistor is used instead of the calculated 111 ohm resistor. This can be done as the error in resistance is less than 1%.

$$\frac{111-110}{111} = \frac{1}{111} = .009 = 0.9\%$$

For all practical purposes, the 0-10 milliampere scale is direct reading when shunted by the 110 ohm resistor. The Greek letter Ω (omega) sometimes printed after the number 110 on the precision resistor represents ohms. Until otherwise instructed, do not trim any of the resistor leads. Connect the following circuit, Figure 2-46, and vary the load so that different currents flow through the circuit, enabling you to practice reading the dial. Remember that the 0-10 ma scale is now direct reading, that is, "2" on the 0-10 scale indicates 2 ma flowing through the circuit, "3" indicates 3 ma, etc.

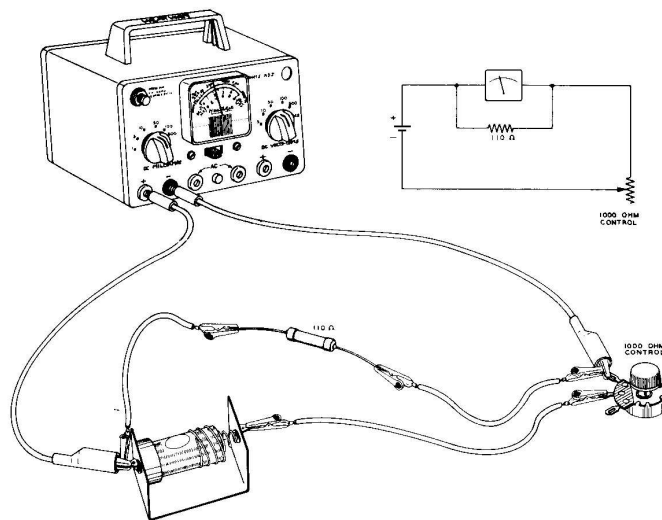

Figure 2-46

Five shunts are to be alternately switched across the meter movement to extend its range. After observing the following calculations of R_x for the 5 milliampere scale, set up diagrams similar to Figure 2-47 and show all mathematics necessary to calculate R_x for the 50, 100 and 500 milliampere scales.

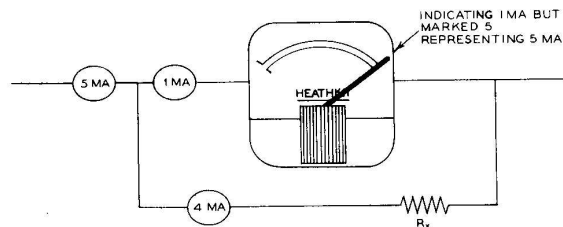

Figure 2-47

Voltage across meter

$$V = IR = .001 \times 1000 \Omega$$

$$V = 1 \text{ volt}$$

Voltage across R_x also equals 1 volt. (Why?)

Current through R_x must be 4 ma (from diagram)

Therefore..... $R_x = \frac{V}{I} = \frac{1 \text{ volt}}{.004 \text{ ampere}}$

$$R_x = 250 \text{ ohms}$$

Answers:

Scale	R_x
50 ma	20 Ω
100 ma	10 Ω
500 ma	2 Ω

It is interesting to note that only pure reasoning is necessary for determining the shunt values. Consider the 0-10 milliampere scale and the following thinking, as shown in Figure 2-48.

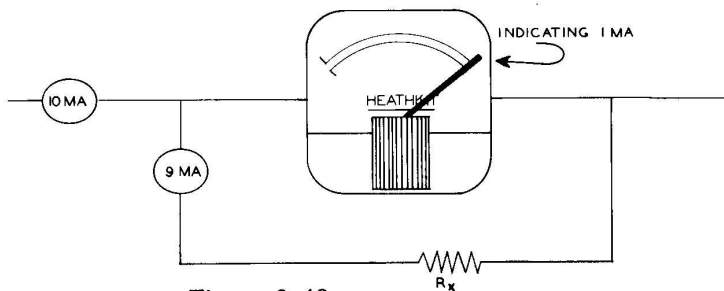

Figure 2-48

We know that 9 milliamperes must flow through the shunt R_x so that 1 milliampere is left to flow through the meter. In order for the R_x shunt to conduct 9 milliamperes around the meter movement, it must be a better conductor by 9 times, compared to the meter. If the meter resistance is 1000 ohms, then a conductor containing 1/9 of this resistance, or 111 ohms, will conduct 9 times more current. The 111 ohm shunt obtained by reasoning is equal to the 111 ohm shunt as calculated by Ohm's Law.

Let us apply this reasoning to the 50 milliampere scale. Refer to Figure 2-49.

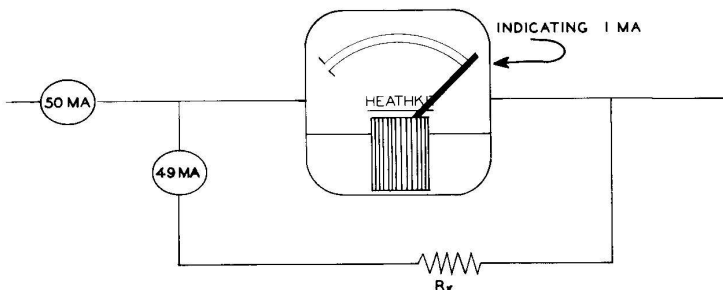

Figure 2-49

The resistance R_x must conduct current 49 times better than the meter movement. The resistance of R_x should then equal $1/49$ of the meter resistance.

$$1/49 \times 1000 = 20.4 \text{ or } 20 \text{ ohms}$$

We see that this agrees with the calculated value. Similar reasoning can be applied to obtain shunt values for the other scales.

If you can answer all of the following questions correctly, it may be assumed that you understand the material in this chapter very well.

QUESTIONS FOR CHAPTER 2

1. Who was the Danish physicist that discovered the fact that current flowing through a conductor created a magnetic field?
2. How can the magnetic field around a wire be strengthened?
3. How can the compass needle be used to compare the strength of the magnetic field at the center and outside rim of the coil?
4. What is a resistor?
5. Carbon resists the flow of current about _____ times more than copper.
6. Describe the 250Ω control. *250 ohms*
7. What is the unit of measure for resistance?
8. Why do we say that the compass needle is indirectly indicating the rate of flow of current through the coil.
9. What is meant when we say something is rotating clockwise?
10. What is done at the back of the meter to make sure that the meter is connected properly to the electrical circuit?
11. What was the reference, or standard, used in the calibrating of the homemade weight scale?
12. How much current in amperes and milliamperes does the EK-1 meter require to cause the needle to indicate full scale?
13. How can a 0-10 milliamperes scale be used to indicate 0-100 milliamperes? *100*
14. The meter for EK-1 is accurate to within what % of full scale?
15. Draw a schematic diagram of a series circuit containing a cell, variable load, and meter to measure the current flowing through the load.
16. Is the rate of flow of current the same in all parts of a series circuit? *Y*
17. State Ohm's Law for resistance. *$R = \frac{V}{I}$*

QUESTIONS FOR CHAPTER 2

1. Who was the Danish physicist that discovered the fact that current flowing through a conductor created a magnetic field? Answer: Hans Christian Oersted.
2. How can the magnetic field around a wire be strengthened? Answer: By forming the wire into a coil.
3. How can the compass needle be used to compare the strength of the magnetic field at the center and outside rim of the coil? Answer: The oscillations of the compass needle are observed at the two places in question. The faster oscillations indicate the stronger magnetic field.
4. What is a resistor? Answer: A device that resists the flow of current.
5. Carbon resists the flow of current about $\overline{3000}$ times more than copper.
6. Describe the 250 Ω control. Answer: The 250 Ω control is merely a curved path of carbon material upon which a slider rotates.
7. What is the unit of measure for resistance? Answer: Ohm.
8. Why do we say that the compass needle is indirectly indicating the rate of flow of current through the coil? Answer: The compass needle is indirectly indicating the rate of flow of current for we are depending on the strength of the magnetic field created by the current to cause the needle to indicate as it does.
9. What is meant when we say something is rotating clockwise? Answer: The object is rotating in the same direction that the hands of a clock rotate.
10. What is done at the back of the meter to make sure that the meter is connected properly to the electrical circuit? Answer: The electrodes at the back of the meter are marked (+) and (-).
11. What was the reference, or standard, used in the calibrating of the homemade weight scale? Answer: The bathroom scale.
12. How much current in amperes and milliamperes does the EK-1 meter require to cause the needle to indicate full scale? Answer: .001 ampere or 1 milliampere.
13. How can a 0-10 milliampere scale be used to indicate 0-100 milliamperes? Answer: The 0-10 scale must be multiplied by 10.
14. The meter for EK-1 is accurate to within what % of full scale? Answer: 5% of full scale.
15. Draw a schematic diagram of a series circuit containing a cell, variable load, and meter to measure the current flowing through the load. (Check drawing with Figure 2-34, Page 38.)
16. Is the rate of flow of current the same in all parts of a series circuit? Answer: Yes.
17. State Ohm's Law for resistance. Answer: The resistance of a circuit, in ohms, is equal to the voltage across this resistance, in volts, divided by the current flowing through this resistance, in amperes.

Solve the following problems:

18.

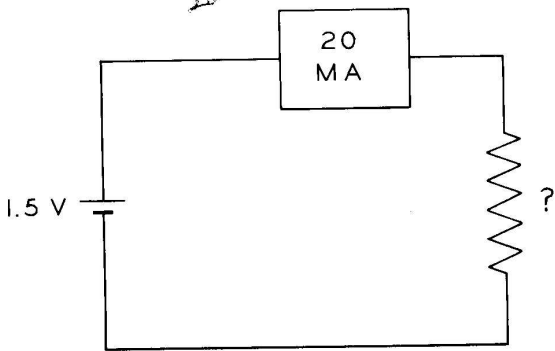

19.

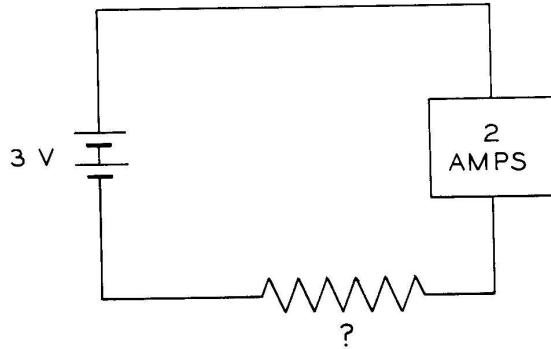

20. What are the three forms of Ohm's Law?

21. If we know the area of a rectangle and the length of one side, how is the width found?

22. If we know the area of a rectangle and the width of one side, how is the length found?

23. Using $V = IR$, change the subject of the formula from "V" to "I" by algebra.

24. A resistor placed across the terminals of a meter is called a _____.

25. Compute the shunt resistance R_x in the following Figure, using either Ohm's Law or pure reasoning.

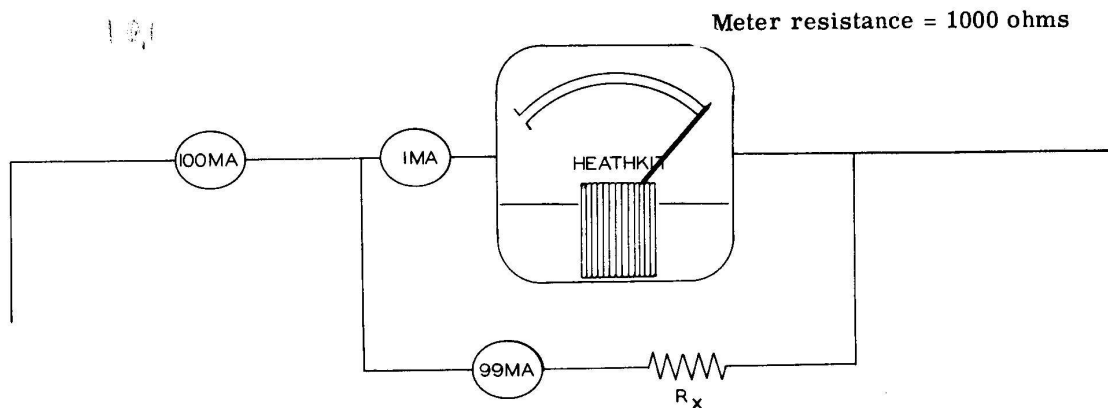

26. If 8 milliamperes are flowing around a circuit and the EK-1 milliammeter is connected to indicate 10 ma full scale, how much current is actually flowing through the meter?

Solve the following problems:

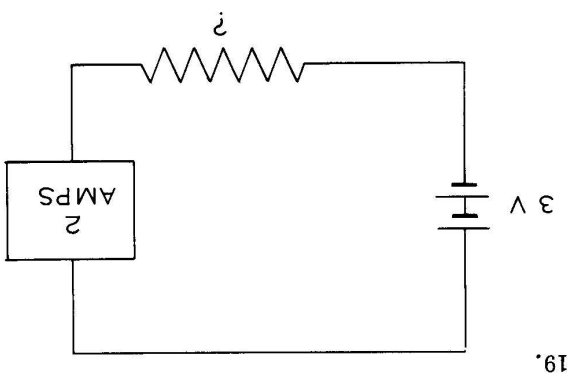
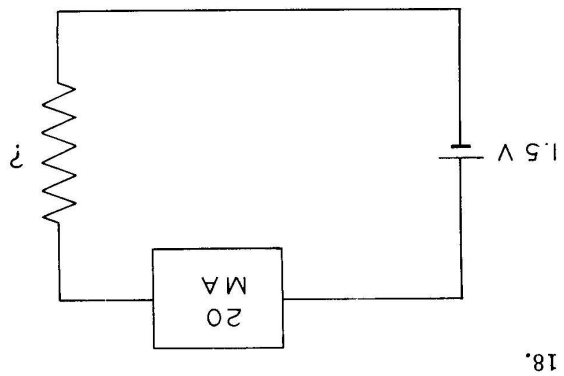

20. What are the three forms of Ohm's Law? Answer: (A) $R = \frac{V}{I}$ (B) $I = \frac{R}{V}$ (C) $V = IR$

21. If we know the area of a rectangle and the length of one side, how is the width found? Answer: The width is found by dividing the area by the length.

22. If we know the area of a rectangle and the width of one side, how is the length found? Answer: The length is found by dividing the area by the width.

23. Using $V = IR$, change the subject of the formula from "V" to "I" by algebra.

Solution: $V = IR$

$$\frac{V}{R} = \frac{IR}{R} \text{ then } \frac{V}{R} = I \text{ or } I = \frac{V}{R}$$

24. A resistor placed across the terminals of a meter is called a shunt.

25. Compute the shunt resistance R_x in the following Figure, using either Ohm's Law or pure reasoning.

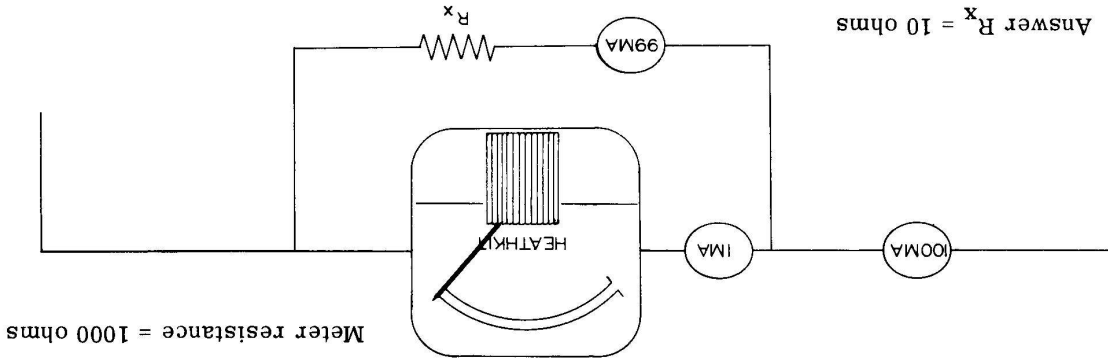

26. If 8 milliamperes are flowing around a circuit and the EK-1 milliammeter is connected to indicate 10 ma full scale, how much current is actually flowing through the meter? Answer: .8 ma.

CHAPTER 3

THE DIRECT CURRENT VOLTMETER AND OHMMETER

THE VOLTMETER

Of the three primary electrical measurements made in electronic work (electrical pressure, current and resistance), electrical pressure is probably most often measured. No electrical apparatus will function unless electrical pressure is present; for unless the electron moves, we cannot obtain any work from it.

It is, therefore, quite necessary that we know if electrical pressure (voltage) is present and if it is of the correct amount.

To understand how the EK-1, 0-1 milliammeter, can be used to indicate voltage, we will start our thinking by asking this question. How much voltage, at points (A) and (B), is necessary to cause a current of one milliampere to flow through the meter, thus making it read full scale?

Figure 3-1 presents the question in the form of a diagram.

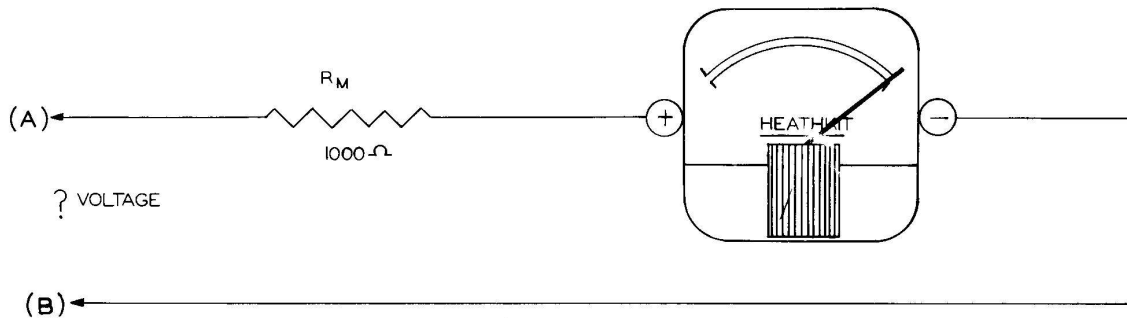

Figure 3-1

To help us remember that the meter contains $1,000 \Omega$ of resistance, the symbol for resistance, labeled R_m , has been inserted in the above circuit.

The solution to this problem comes about by knowing that one milliampere must be flowing through the meter for it to indicate full scale and that the meter resistance is $1,000 \Omega$. Applying Ohm's law for voltage we obtain the result that one volt must be present between points (A) and (B) for

$$V = IR$$

$$V = (.001) \times (1,000)$$

$$V = 1 \text{ volt}$$

Full scale deflection can be thought of as indicating one volt of electrical pressure between points (A) and (B). If points (A) and (B) are used as test leads, one volt between the test leads will always cause the meter to indicate full scale. Since this is the case, we can mark the full scale indication "one volt". This basic meter movement can be thought of as a 0-1 volt voltmeter as well as a 0-1 milliammeter.

The next question that comes to mind is where will the pointer be if only 1/2 volt (.5 volt) is present between points (A) and (B)? See Figure 3-2.

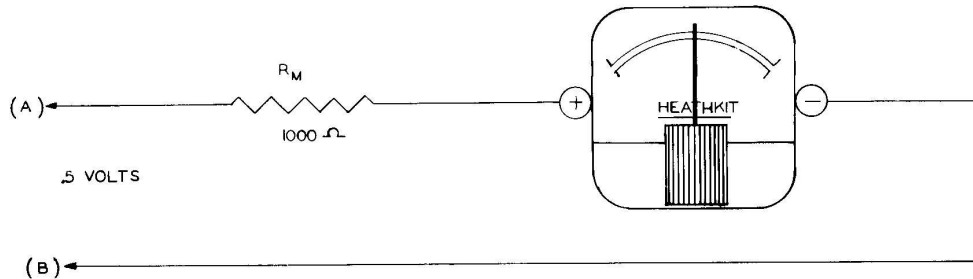

Figure 3-2

Actually, we are asking, what current will the meter indicate when .5 volt is present between the test leads? Ohm's Law for current tells us that the meter should be indicating .5 ma for

$$I = \frac{V}{R}$$

$$I = \frac{.5 \text{ volts}}{1,000 \text{ ohms}}$$

$$I = .0005 \text{ ampere or } .5 \text{ ma}$$

$$I = .5 \text{ ma}$$

The meter deflection can now be thought of as indicating .5 volt of electrical pressure between points (A) and (B) and therefore, the .5 ma indication can also be marked .5 volts.

Noting that now one ma also represents one volt, and .5 ma represents .5 volt, it is true that all 0-1 ma indications are the same as 0-1 volt indications. BASICALLY, MOST VOLTMETERS ARE AMMETERS CALIBRATED IN VOLTS.

A scale as low as a 0-1 volt scale is usually not as advantageous as higher scales because cell voltages start at 1.5 volts and, therefore, a 0-1 volt scale is useless for measuring the electrical pressure of even a single cell. For this reason, a 0-5 volt scale is the first basic scale of the EK-1 meter.

EXTENDING THE RANGE OF THE VOLTMETER

THE FIVE VOLT SCALE

Again, it must be realized that when the test leads (A) and (B) of the EK-1 meter are connected to a 5 volt DC source, only 1 milliampere must be allowed to flow through the meter. For this reason, R_X must be inserted in the circuit. See Figure 3-3.

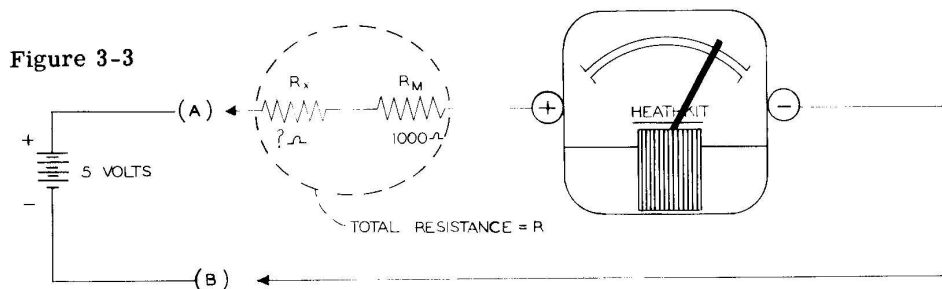

Figure 3-3

Using Ohm's Law

$$R = \frac{V}{I} = \frac{5 \text{ volts}}{.001 \text{ ampere (1 ma)}}$$

$$R = 5,000 \Omega \text{ (total circuit resistance)}$$

The total required circuit resistance (R) is 5,000 Ω . Since the meter presents 1,000 Ω to the circuit, an additional resistance of 4,000 Ω must be included in the circuit. This resistance is indicated as R_x in Figure 3-3.

Mathematically stated, the resistance to be added (R_x) is equal to the total required circuit resistance minus the meter resistance.

$$\begin{aligned} \text{or} \quad R_x &= R - R_m \\ R_x &= 5,000 - 1,000 \\ R_x &= 4,000 \Omega \end{aligned}$$

Because 1 milliampere is flowing through the circuit, the pointer will indicate full scale. Marking this point "5" represents 5 volts present at points (A) and (B), the test leads. Using Ohm's Law, we can calculate the current flowing around the circuit for cell voltages of 4, 3, 2, 1 and 0 volts.

$$\begin{aligned} I = \frac{V}{R} &= \frac{4}{5000} = .0008 \text{ ampere or } .8 \text{ ma} \\ &\frac{3}{5000} = .0006 \text{ ampere or } .6 \text{ ma} \\ &\frac{2}{5000} = .0004 \text{ ampere or } .4 \text{ ma} \\ &\frac{1}{5000} = .0002 \text{ ampere or } .2 \text{ ma} \\ &\frac{0}{5000} = 0 \text{ ampere or } 0 \text{ ma} \end{aligned}$$

Marking the .8 ma point on the scale "4 volts", .6 ma "3 volts", .4 ma "2 volts", .2 ma "1 volt" and the 0 ma "0 volts" completes the calibration of the 0-1 milliammeter into a direct reading 0-5 voltmeter.

As it turns out, the previously discussed 0-5 ma scale is the same as the 0-5 volt scale and, therefore, one scale is used to indicate either voltage or current, depending on how the meter is connected in the circuit.

Construct the following circuit, Figure 3-5, and measure the voltage across each lamp.

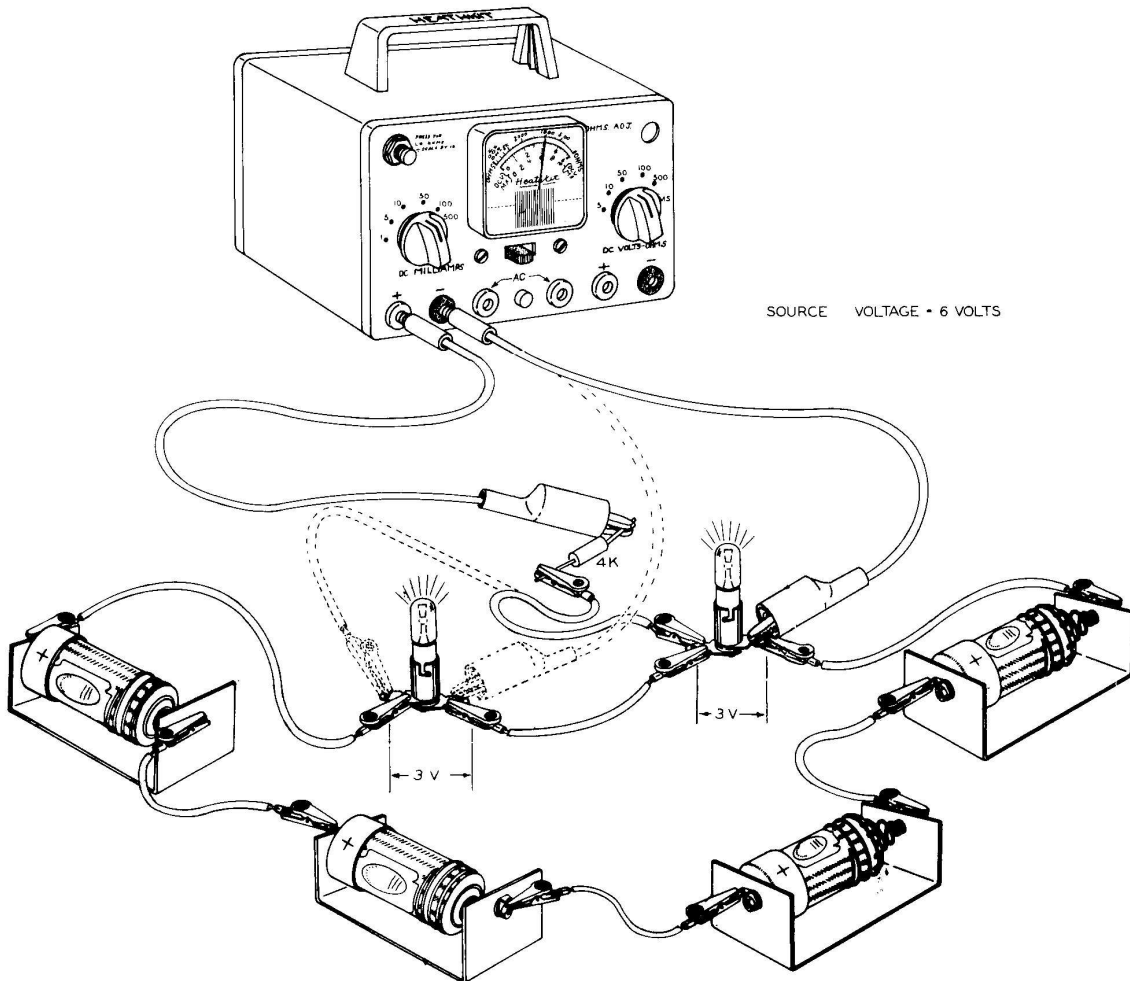
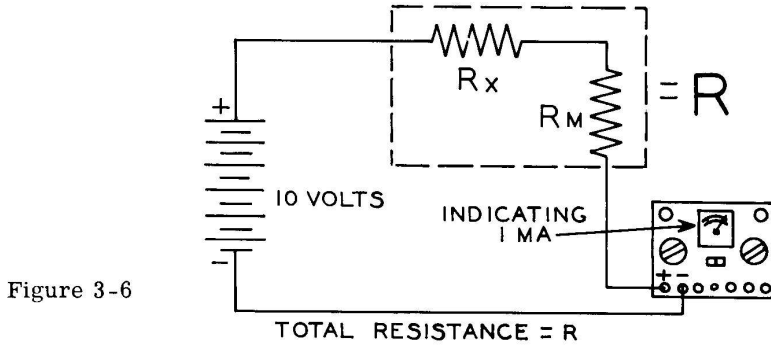

Figure 3-5

To measure the voltage across each lamp, both test leads must be moved as indicated by the dotted lines. Note that the voltage drop across each lamp (3 volts) equals the source voltage (6 volts). If you try to measure the total voltage (the voltage across both lamps of 6 volts) the pointer will indicate past full scale as full scale represents 5 volts.

THE 0-10 VOLT SCALE

Again, it must be realized that when the test leads of the EK-1 meter are connected to any DC source, only 1 milliampere must be allowed to flow through the meter. See Figure 3-6.



Using Ohm's Law $R = \frac{V}{I} = \frac{10 \text{ volts}}{.001 \text{ ampere (1 ma)}}$

$R = 10,000 \Omega$ (total circuit resistance)

and $R_x = R - R_m$ (total circuit resistance - meter resistance)

Therefore $R_x = 10,000 \Omega - 1,000 \Omega$

$R_x = 9,000 \Omega$ or 9 K

Figure 3-7 shows the placement of the 9 K resistor so that a maximum of 6 volts can be indicated by the meter on the 0-10 volt scale.

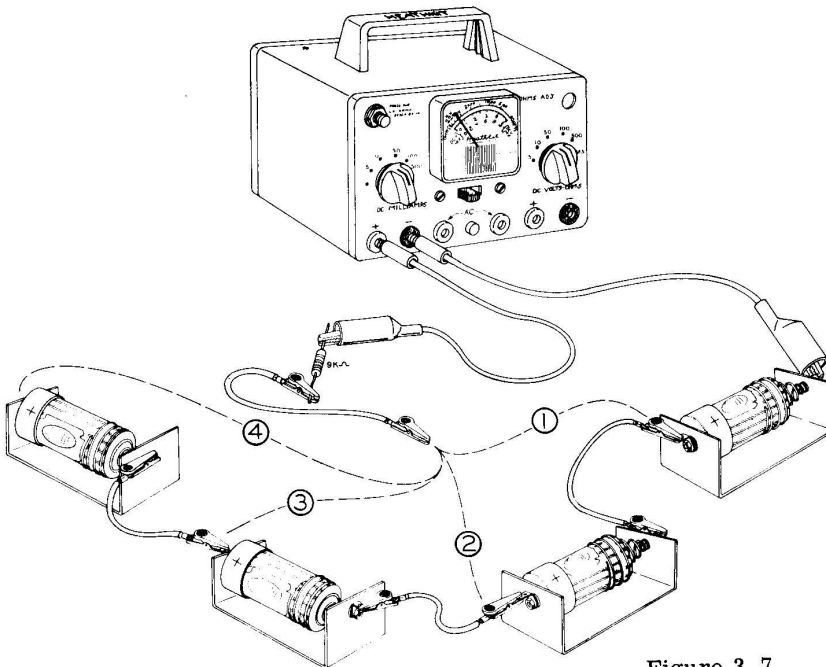

Figure 3-7

Using Ohm's Law again, we can calculate the current flowing around the circuit for voltages of 9, 8, 7, 6, 5, 4, 3, 2 and 1 volt.

$$I = \frac{V}{R} = \frac{9}{10,000} = .0009 \text{ or } .9 \text{ ma}$$

$$\text{and } \frac{8}{10,000} = .0008 \text{ or } .8 \text{ ma}$$

$$\frac{7}{10,000} = .0007 \text{ or } .7 \text{ ma}$$

$$\frac{6}{10,000} = .0006 \text{ or } .6 \text{ ma}$$

$$\frac{5}{10,000} = .0005 \text{ or } .5 \text{ ma}$$

$$\frac{4}{10,000} = .0004 \text{ or } .4 \text{ ma}$$

$$\frac{3}{10,000} = .0003 \text{ or } .3 \text{ ma}$$

$$\frac{2}{10,000} = .0002 \text{ or } .2 \text{ ma}$$

$$\frac{1}{10,000} = .0001 \text{ or } .1 \text{ ma}$$

Marking the .8 ma point on the scale "8 volts", .6 ma "6 volts", .4 ma "4 volts", .2 ma "2 volts" and 0 ma "0 volts" completes the calibration of the 0-1 milliammeter into a Direct Reading 0-10 volt voltmeter. As it again turns out, the previously discussed 0-10 ma scale is the same as the 0-10 volt scale. The same scale is used to read either volts or ma. A resistor such as the 4 K or 9 K resistor connected in series with the meter movement is called a "multiplier resistor".

Using the lead connected to the free end of the 9 K resistor, touch the appropriate lamp terminal and read the indicated voltages of 3 and 6 volts on the 0-10 volt scale, Figure 3-8.

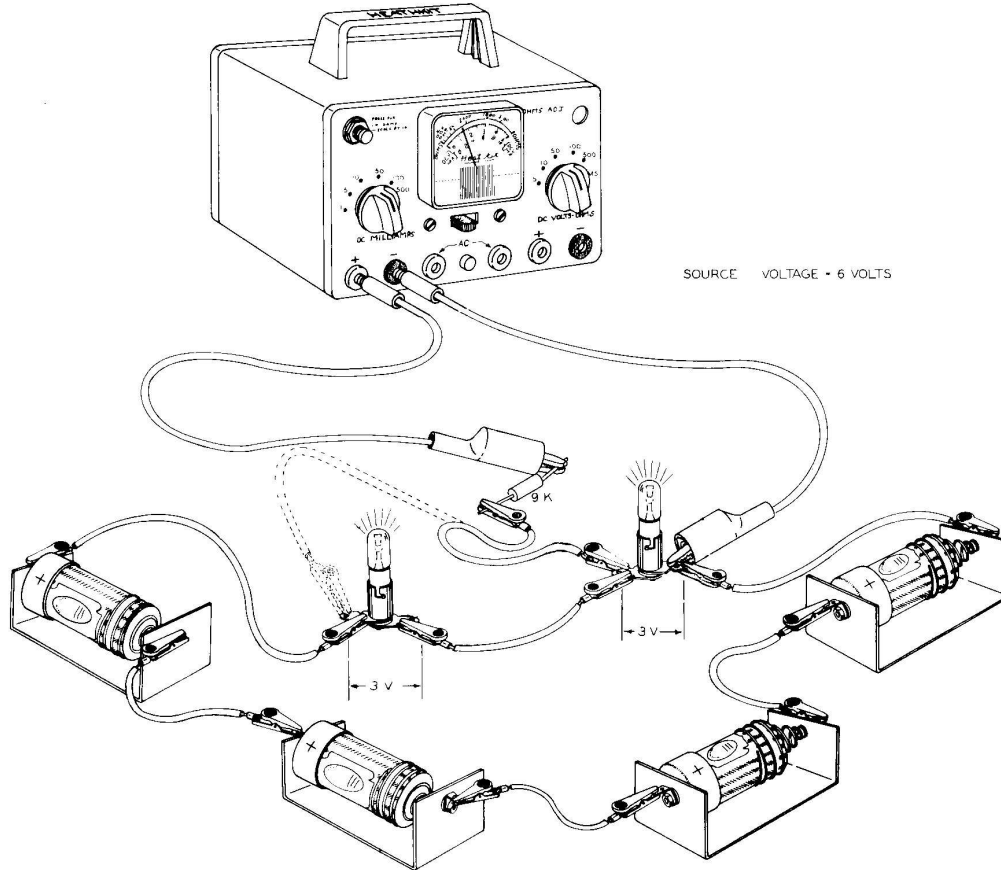

Figure 3-8

Having observed the calculations of the 4 K and 9 K multiplier resistors, set up similar diagrams as shown in Figure 3-9, and calculate the multipliers (R_x) necessary for use with the 50, 100 and 500 volt scales.

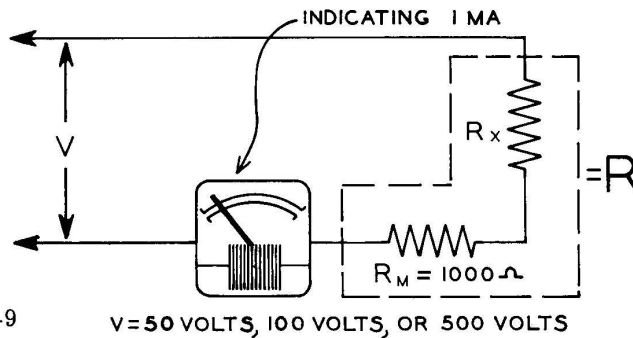

Figure 3-9

50 K, 100 K and 500 K precision resistors were used in place of the 49 K, 99 K and 499 K calculated values, as the error in resistance is much less than the 5% accuracy of the meter movement.

MAKING AN OHMMETER

Construct the following circuit, as shown in Figure 3-10.

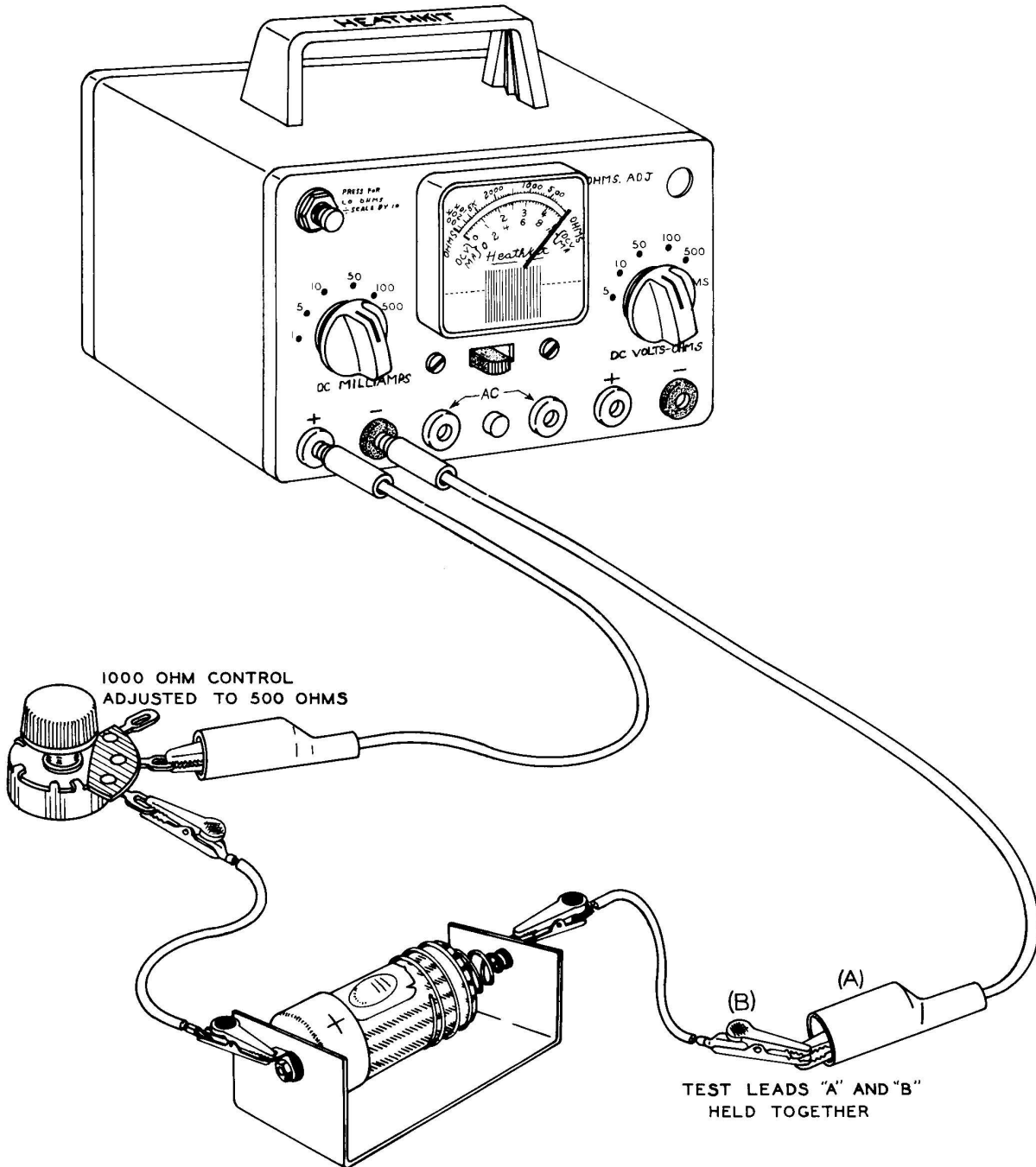

Figure 3-10

Adjust the 1,000 Ω control (called an "ohms adjust") until the pointer reads full scale. The full scale indication again tells us that 1 ma is flowing through the circuit. Assuming the cell pressure of 1.5 volts, the circuit resistance must be 1,500 Ω for

$$R = \frac{V}{I} = \frac{1.5 \text{ volts}}{.001 \text{ ampere (1 ma)}} = 1,500 \Omega$$

{ Because the meter resistance is 1,000 Ω the 1,000 Ω control must be set at 500 Ω .

Since the two test leads (A) and (B) were held together in order to complete the circuit, zero resistance now exists between the two leads. The full scale position is then marked "0", as this is where the pointer rests when there is zero resistance between the two leads. Now clip a 1,000 Ω resistor (brown-black-red and silver bands painted on the body of the resistor) between the two test leads, as shown in Figure 3-11, and observe the new location of the pointer.

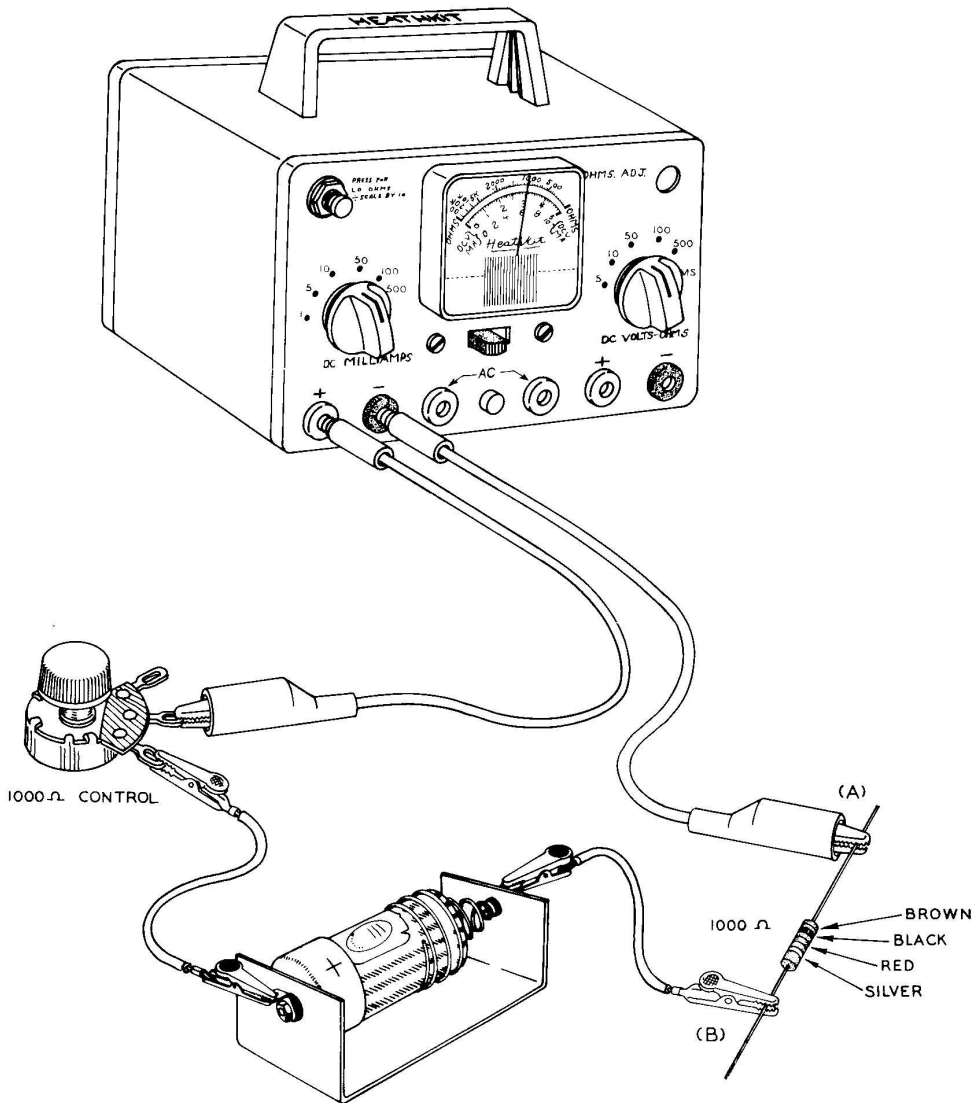

Figure 3-11

The pointer has dropped back from full scale indication, for adding resistance to the circuit cuts down the amount of current flowing through the circuit. Using Ohm's Law, we will calculate the amount of current flowing.

$$I = \frac{V}{R} = \frac{1.5 \text{ volts}}{1,000 + 1,000 + 500} = \frac{1.5}{2,500} = .0006 \text{ ampere or } .6 \text{ ma}$$

↓
↓
↓
 Meter Resistance Resistor Control

Observing the 0-10 ma scale and mentally changing it to a 0-1 ma scale, we see that the number 1,000 has been placed approximately in line with .6 ma. Replace the 1 K ohm resistor with a 4 K ohm precision resistor and observe the new location of the pointer. The pointer registers a little less than .3 ma and checking with Ohm's Law,

$$I = \frac{V}{R} = \frac{1.5 \text{ volts}}{1,000 + 4,000 + 500} = \frac{1.5 \text{ volts}}{5,500 \Omega} = .00027 \text{ or } .27 \text{ ma}$$

↓
↓
↓
 Meter Resistance Resistor Control

It should now be evident that increasing the resistance between the two test leads from 0 to 20 K Ω simply decreases the current from 1 milliampere to almost 0, and thus the milliampere meter current indications along the scale marked in ohms allows a direct reading in ohms to be accomplished. Note that high current indicates low resistance and low current indicates high resistance, causing resistance indications to be in reverse to current indications.

THE LO OHM'S CIRCUIT

So that resistance less than 100 Ω can be read more accurately, a LO ohms circuit is added. This consists of shunting 9/10 of the current around the meter and zero-adjust so that only 1/10 of the current flowing through the resistor under measurement will be indicated by the meter, thus dividing the ohms scale by 10. A 100 Ω resistor would then be indicated at the 1000 Ω mark.

To calculate the value of the shunt resistance to be placed across the ohms-adjust and meter, it is only necessary to reason that the shunt must carry 9 times more current than the ohms-adjust and meter. In order for the shunt to carry 9 times more current, the resistance must be 1/9 of the combined resistance of the ohms-adjust and meter. The ohms-adjust is set at 500 ohms and the meter movement is 1,000 Ω , making a total of 1,500 Ω . The shunt resistance is then 1/9 of 1,500 Ω , or 166 Ω .

Construct the following circuit, Figure 3-12, and observe what happens when the lead connected to the 166 Ω resistor is touched to the positive cell terminal, thus shunting the ohms-adjust and meter.

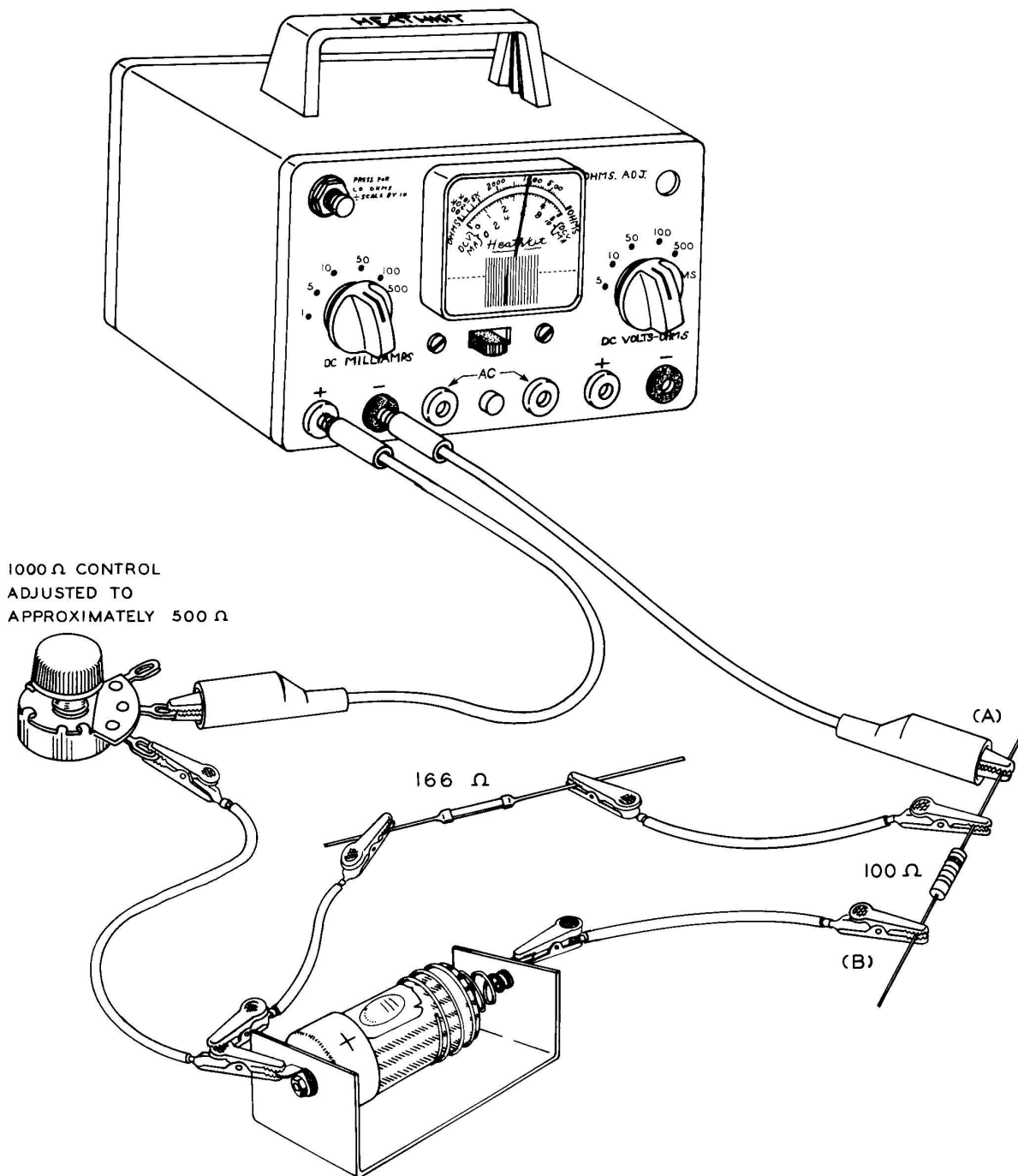

Figure 3-12

You probably wonder why the meter is not directly shunted rather than including the ohms-adjust. Remove the 100 Ω resistor and touch the remaining leads together, as shown in Figure 3-13. If necessary, adjust the ohms-adjust so that the meter again indicates 0 resistance (full scale).

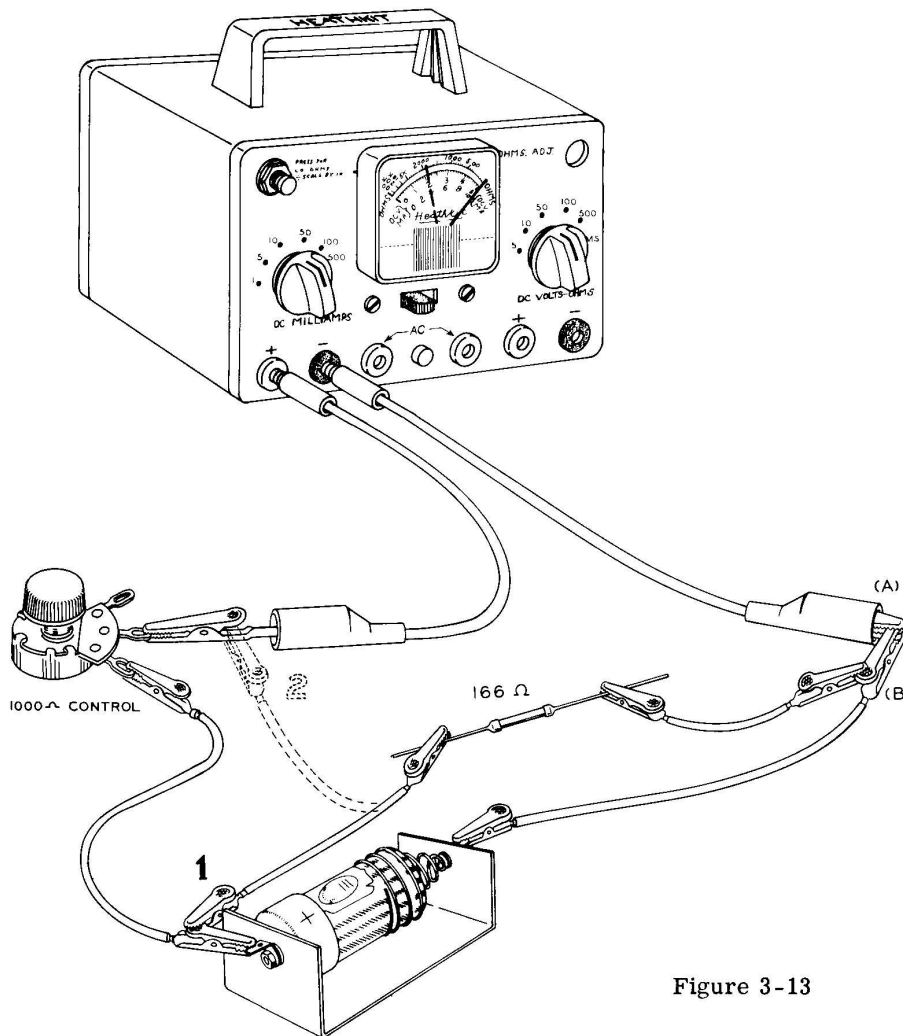

Figure 3-13

Now touch the lead from the free end of the 166 Ω resistor to the positive cell terminal, as before, and note the meter indication. You probably notice a very slight needle movement which is indicating a very small voltage drop from the cell. A slight adjustment of the ohms-adjust will correct this fault. Now place the lead from the free end of the 166 Ω resistor to the positive meter test lead. The needle falls way back, indicating about 2000 Ω of resistance, and yet zero resistance exists between leads (A) and (B) as they are held together. Zero resistance should be indicated whether the 166 Ω resistance is connected or not, and this condition existed at connection "1". It is for this reason that the ohms-adjust, as well as the meter, must be shunted.

We have discussed the 0-1 milliammeter and how to extend its current measuring range, the voltmeter and how to extend its range, and finally the ohmmeter and how to make it indicate low resistance. We will now assemble the meter in its permanent form, first as a milliammeter, then as a voltmeter, and finally as an ohmmeter.

THE MILLIAMMETER

- (/) Mount the $1000\ \Omega$ control next to the words "OHMS-ADJ", with terminals as indicated by Figure 3-14. Attach the small black knob to the shaft.

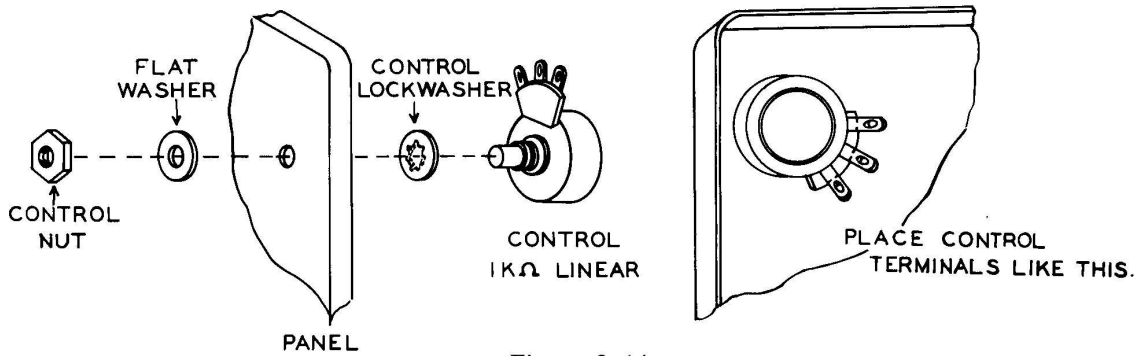

Figure 3-14

- (/) Unsolder the wire from the red banana jack. Trim this wire appropriately and resolder it to slide switch terminal (B). See Figure 3-15.

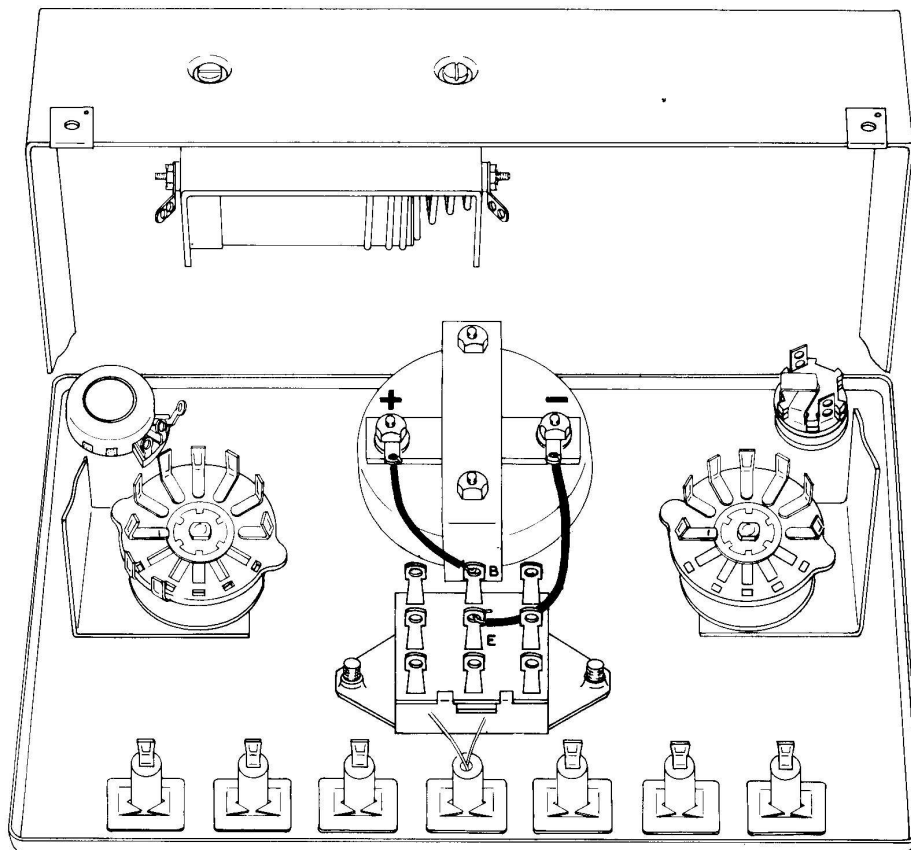

Figure 3-15

- () In the same manner, unsolder the wire from the black banana jack, trim and resolder it to slide switch terminal (E), Figure 3-15.

NOTE: The slide switch is used to connect the meter in parallel with shunts when switched to the left (measuring current), or the slide switch connects the meter in series with the multiplier resistors when switched to the right (measuring voltage, also resistance). To understand the mechanical action of the switch, study Figure 3-16A and B.

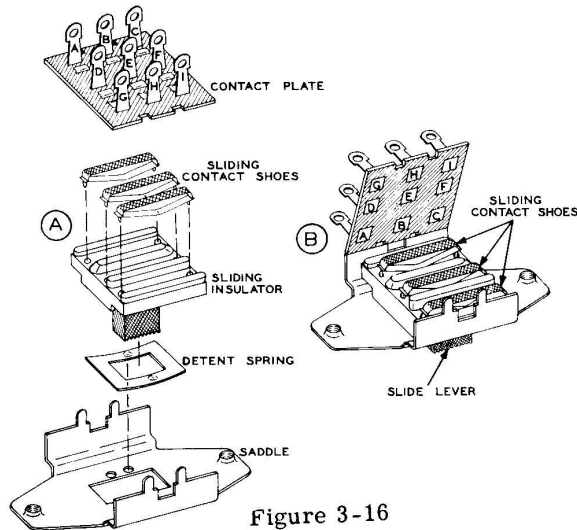

Figure 3-16

The "sliding insulator" houses three "sliding contact shoes" in such a way that when the slide lever is moved back and forth, the sliding contact shoes also move. In the position shown, the sliding contacts are making contact with contacts BC, EF and HI. See Figure 3-16B. If the slide lever is moved to the left, contacts AB, DE and GH are connected together. It should be noted that contacts B, E and H are used, whether the slide lever is in the left or right position. Figure 3-17 shows a schematic symbol for the slide switch used in the EK-1.

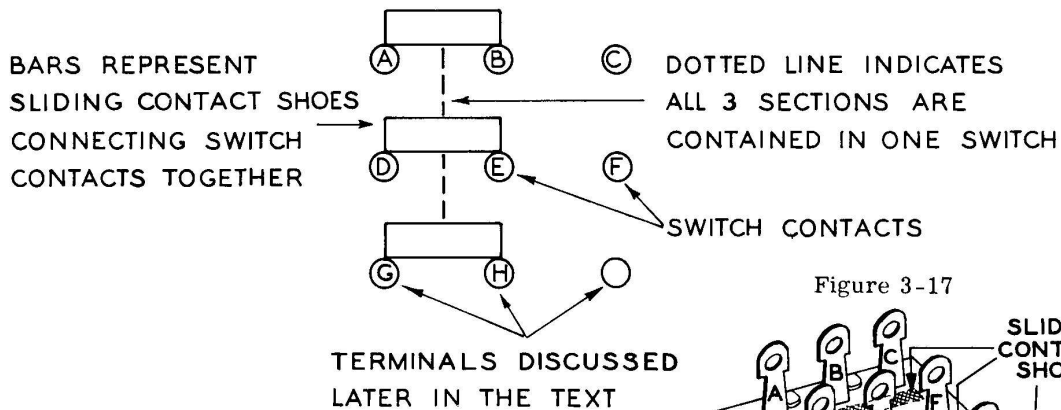

Figure 3-17

Observe the front panel and then move the switch slide lever to the MA position, if it is not already in this position. Observing the switch from the back, as in Figure 3-18, it should be apparent that the contact shoes are connecting contacts BC and EF.

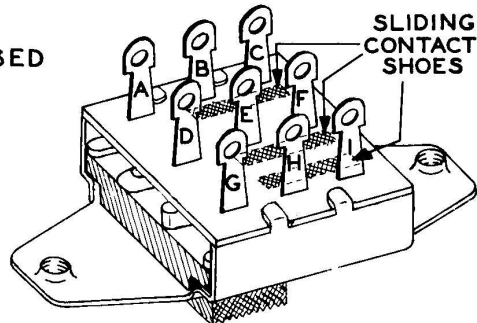

Figure 3-18

Using a pencil, complete the wiring in Figure 3-19 by observing the Schematic Diagram below Figure 3-19.

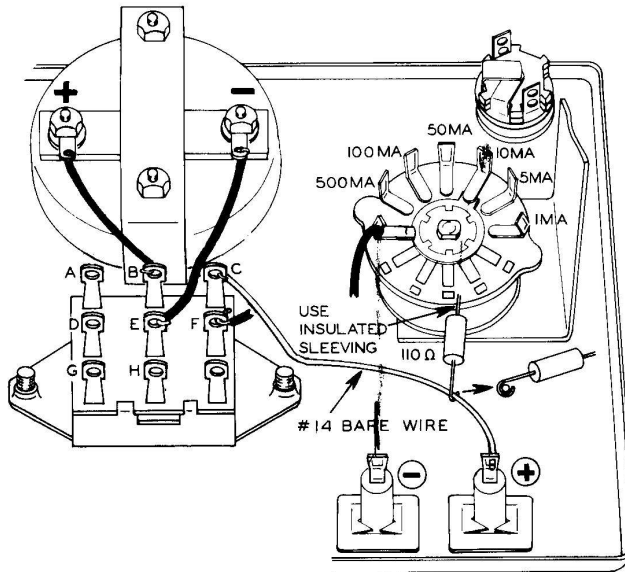
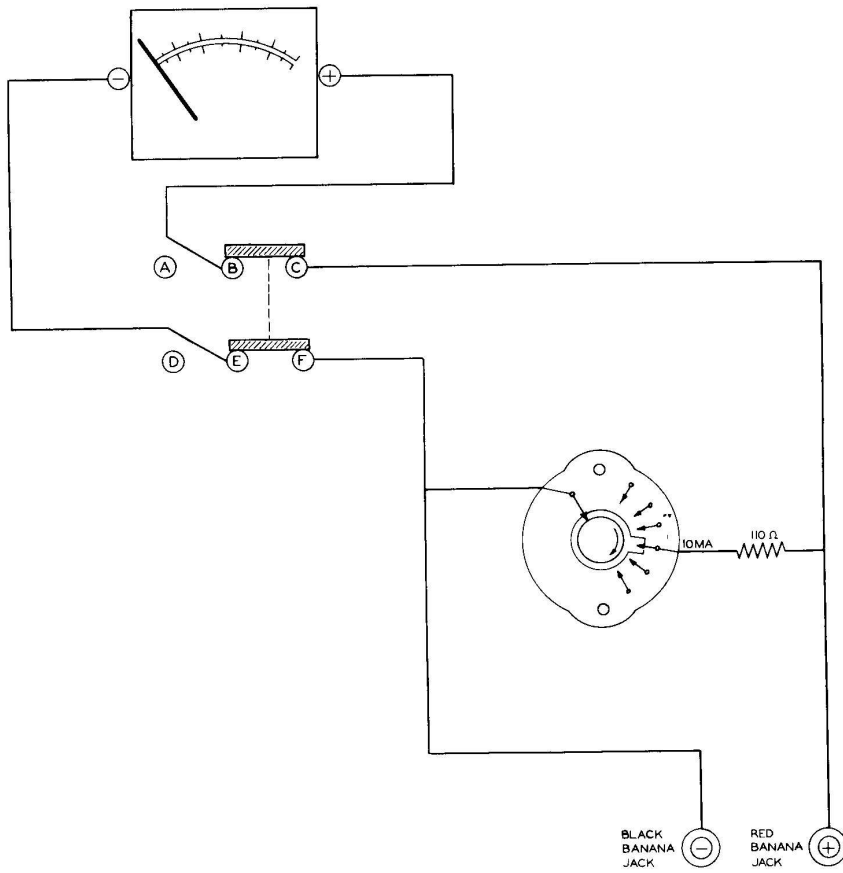

Figure 3-19



Correct your finished drawing with Figure 3-19A in the Appendix, and then wire the front panel as shown in your corrected Figure 3-19. Solder all connections.

Study the Schematic Diagram below Figure 3-19 and observe that the 110 ohm precision resistor is connected in parallel across the meter terminals, as was the case when the circuit of Figure 2-46, Page 52, was constructed. It should be evident that even though switches complicate the physical construction of this electrical circuit, it still remains that electrically, the commercial meter is the same as Figure 2-46.

- () After making sure that the pointer knob is set at 10 ma, insert one red test lead at the red (+) banana jack and one black test lead at the black (-) banana jack. Connect the alligator clips to the test circuit, Figure 3-20, and vary the load (control), reading the current on the 10 ma scale.

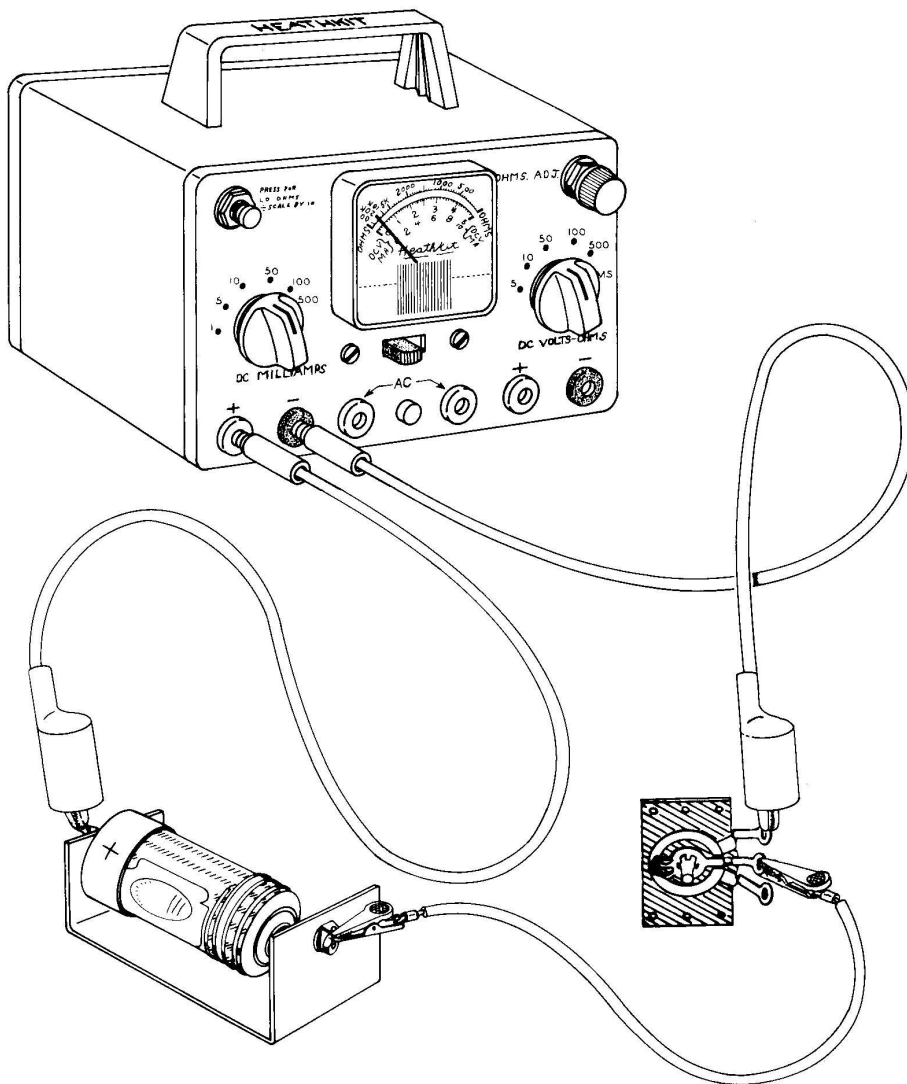

Figure 3-20

If the meter does not indicate current flowing through the circuit, do not progress any further until you find the difficulty. Having some other person check your work is sometimes helpful.

If everything seems as it should be, disconnect the alligator clips, and with pencil complete the resistor leads in Figure 3-21.

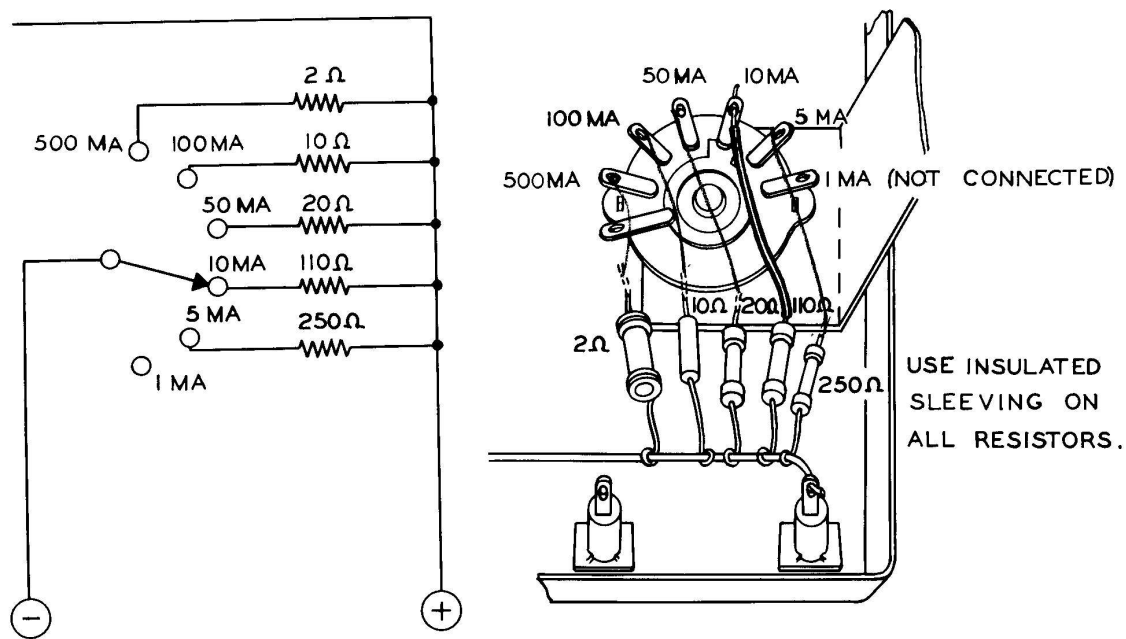

Figure 3-21

Check your penciled connections with Figure 3-21A in the Appendix and if correct, solder in these resistors as shown in your drawings.

Why is the contact for the 1 milliamperere scale not used? The answer should be obvious, for the meter is basically a 1 milliamperere movement and therefore no excess of current exists to be bypassed when measuring currents of 1 milliamperere or less.

This essentially completes the milliammeter circuit. The 0-1 milliammeter is now capable of measuring current flow from 0 to 500 milliampereres in six ranges.

THE VOLTMETER

Move the switch slide lever to the DC VOLTS-OHMS position. Observing the switch from the back as in Figure 3-22, it should be apparent that the sliding contact shoes are connecting contacts AB and DE. Using a pencil, complete the wiring in Figure 3-22 by observing the Schematic Diagram below Figure 3-22.

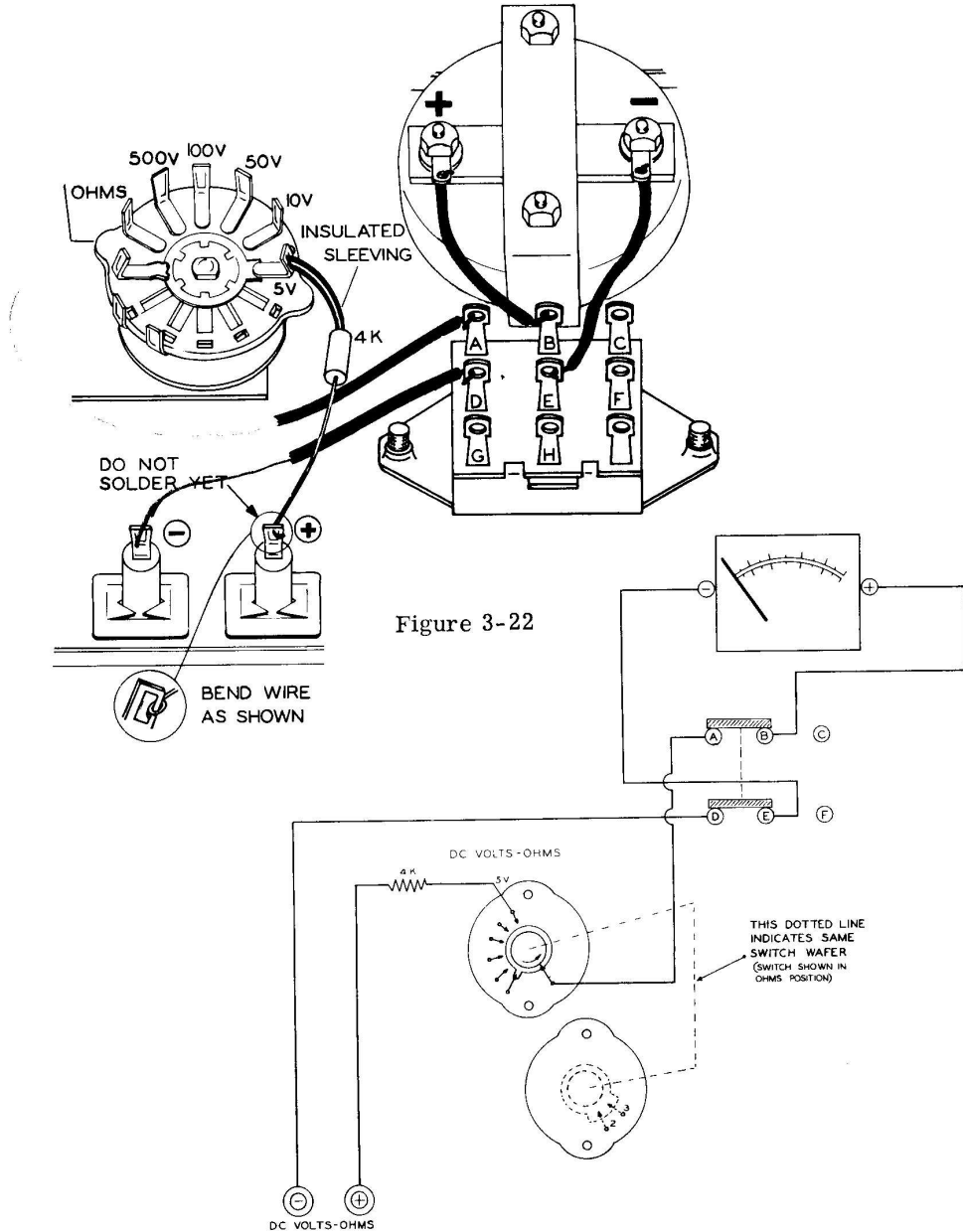

Correct your finished drawing with Figure 3-22A in the Appendix, and then wire the front panel as shown in your corrected Figure 3-22. Solder all connections except the red banana jack connection.

Study the Schematic Diagram below Figure 3-22 and observe that the 4 K ohm precision resistor is connected in series with the meter, as was the case when the circuit of Figure 3-4, Page 62, was constructed.

Even though the switches complicate the physical construction of this electrical circuit, it still remains that electrically the commercial meter is the same as Figure 3-4.

- ✓) After making sure that the pointer knob is set at 5 volts, insert the red and black test leads in their appropriate banana jacks. Connect the alligator clips to the test circuit, Figure 3-23, reading the cell voltage of 1.5 volts on the 5 volt scale.

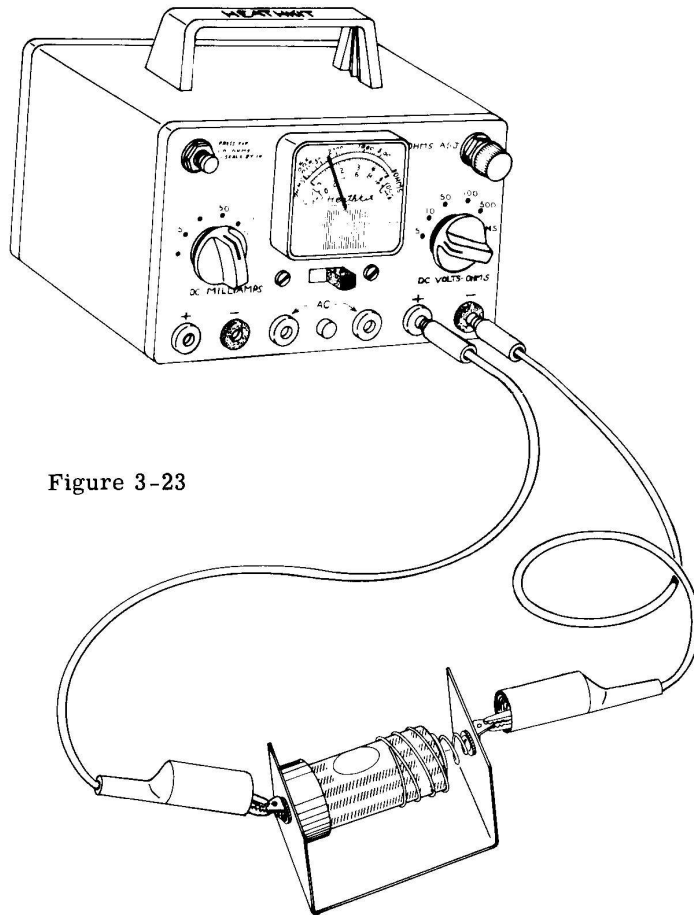

Figure 3-23

If the meter does not indicate voltage from the cell, do not progress any further until you find the difficulty. If everything seems as it should be, disconnect the alligator clips and with pencil complete the resistor leads in Figure 3-24.

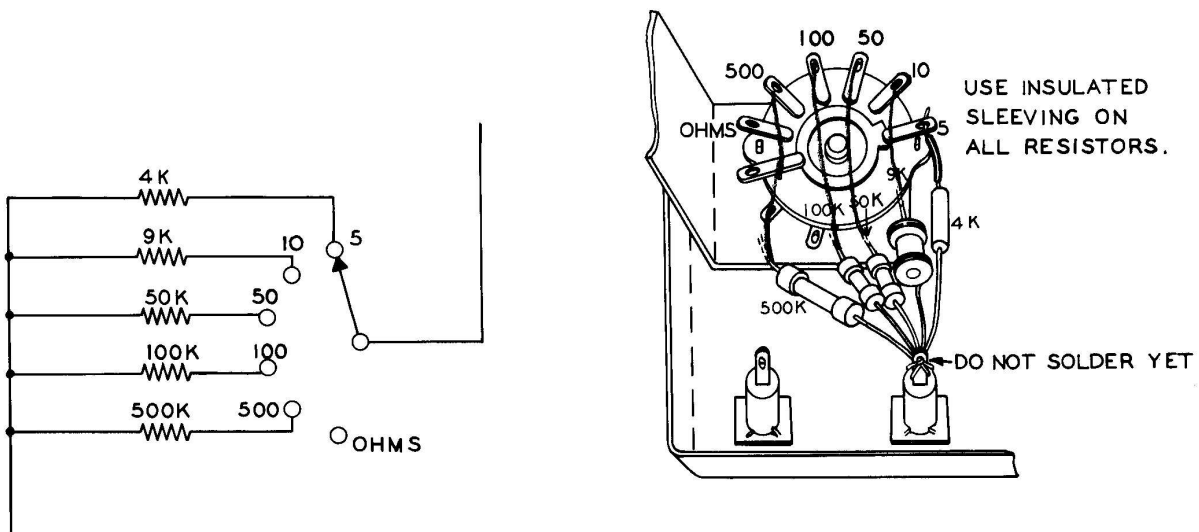

Figure 3-24

Check your penciled connections with Figure 3-24A in the Appendix and if correct, solder in these resistors as shown in your drawing except the red banana jack as one more connection remains to be connected.

This completes the voltmeter circuit. The 0-1 milliammeter is now capable of measuring voltages from 0 to 500 volts in five ranges.

THE OHMMETER

- (✓) Mount one of the battery holders behind the meter, using two #6-32 x 3/8" BHMS, lockwashers and nuts, as shown in Figure 3-25.

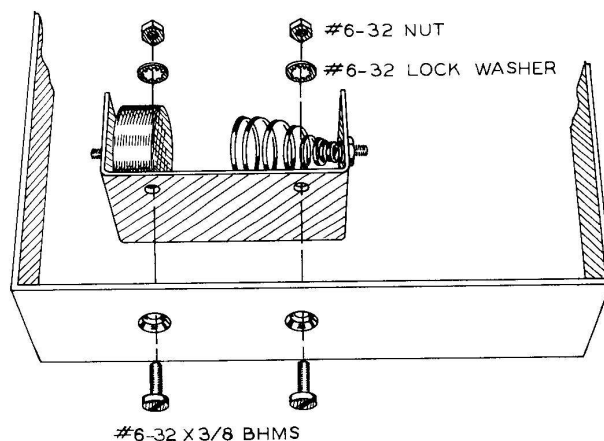

Figure 3-25

Using a pencil, complete the wiring in Figure 3-26 by observing the Schematic Diagram below Figure 3-26.

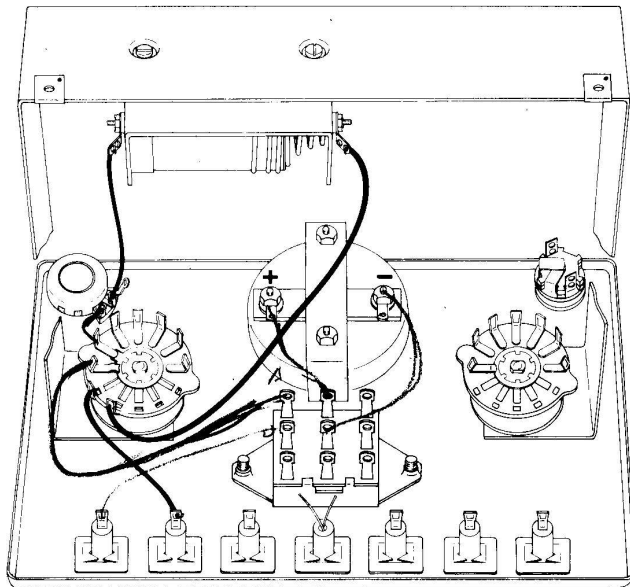
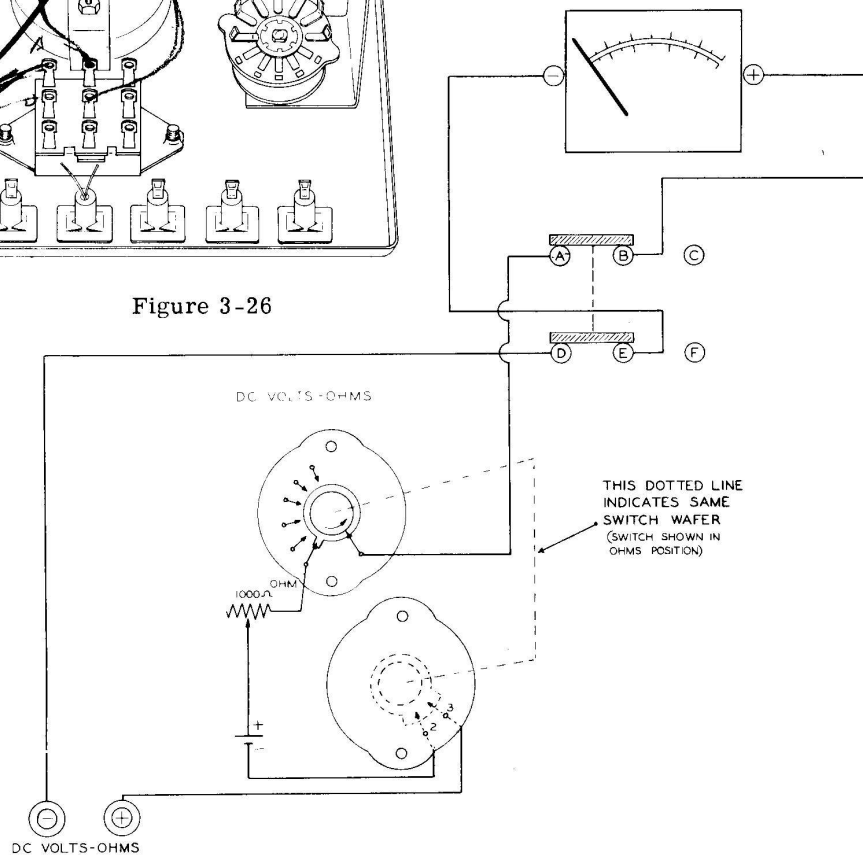

Figure 3-26



Correct your finished drawing with Figure 3-26A in the Appendix and wire in those wires not already done, by observing your corrected Figure 3-26. Solder all connections except the middle terminal on the ohm-adjust.

Note that the connection between the negative cell terminal and the positive banana jack passes through contacts on the rotary switch. This is done so that high voltage under measurement cannot arc from the cell to the cabinet or other internal parts. In other words, the ohms circuit is completely isolated when voltage measurements are made.

Using a pencil, complete the wiring in Figure 3-27 by observing the Schematic Diagram below Figure 3-27.

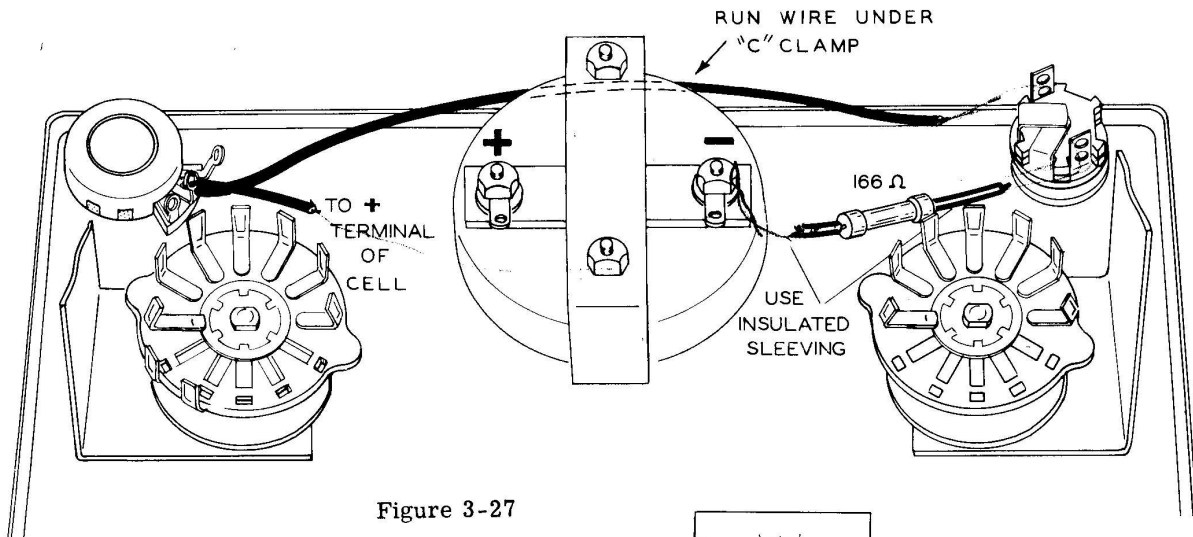
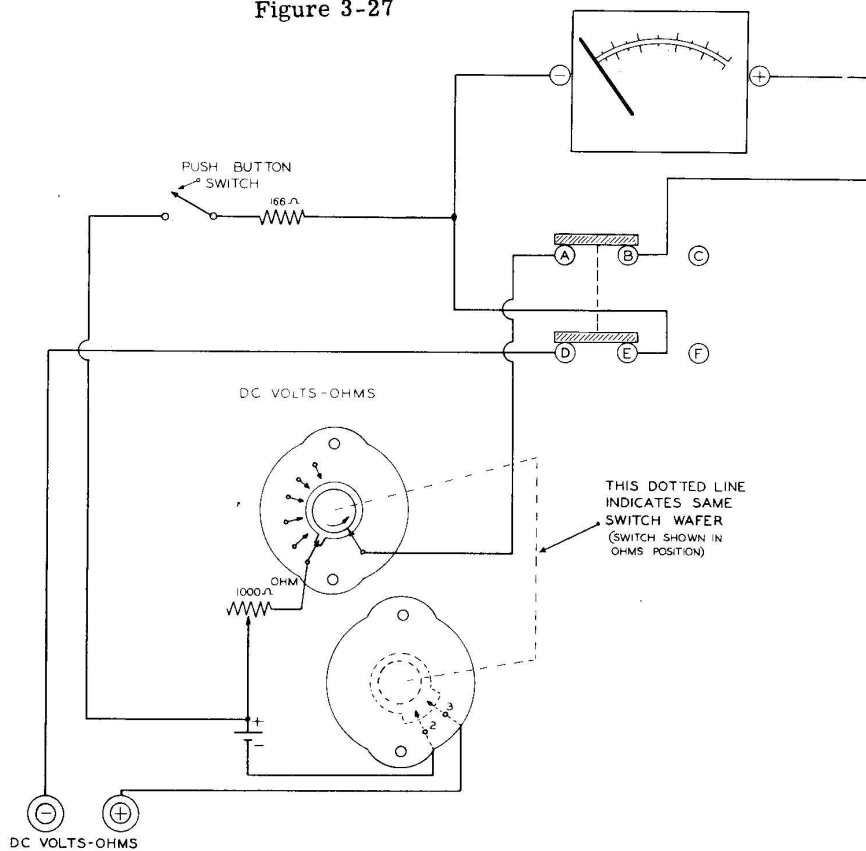

Figure 3-27



Check your penciled connections with Figure 3-27A in the Appendix and, if correct, solder the connections.

Again, the Schematic Diagram below Figure 3-27 is basically the same electrical circuit as Figure 3-12, Page 70. To check the LO ohms scale, short the test leads together and if necessary, adjust for zero resistance. Next, place a 100 ohm resistor (brown-black and brown colored bands painted on resistor) between the alligator clips, as illustrated in Figure 3-28.

Figure 3-28

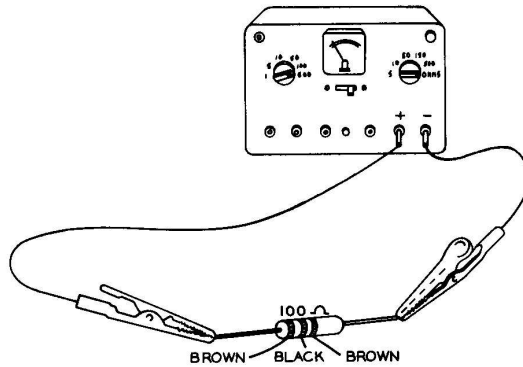

The pointer should drop back one division, indicating 100 ohms. Now press the LO ohms button. The needle should fall back to about 1,000 and, dividing by ten, this indicates 100 ohms. If the pointer does not fall back to the 1,000 indication when the LO ohms button is pressed, do not go any further until you find the difficulty. If the wiring is correct, the fault might be in the 166 ohm resistor. Unsolder the resistor and measure its resistance with the ohmmeter. If the ohmmeter indicates between one and two divisions back from zero, then the resistance is correct, as you will recall these divisions indicate 100 and 200 ohms. If the needle does not move at all, this indicates an open resistor.

This completes the two ohmmeter circuits. After the next two items are taken care of, your EK-1 kit will be finished.

One of the important features of this kit is that current and voltage can be read from the meter without disturbing the circuit under test. The slide switch allows this feature as it switches the meter terminals between the voltage circuit and the current circuit. The milliammeter shunts stay in the circuit regardless of the position of the slide switch.

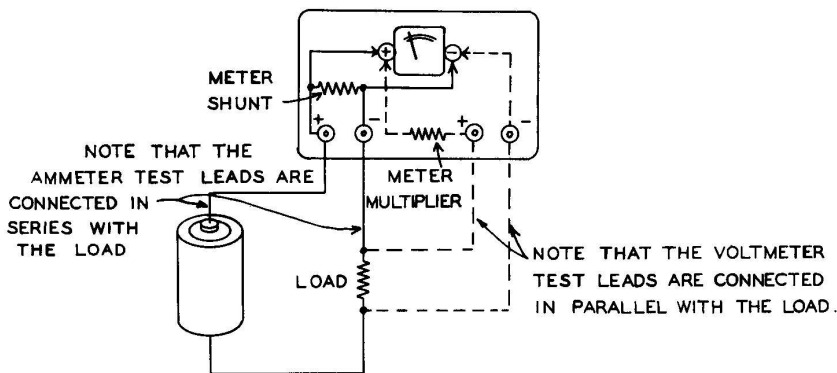

Figure 3-29

Figure 3-29 shows the meter terminals switching between shunt and multiplier resistors. If the meter shunt did not stay in the circuit when the meter terminals were switched to read VOLTAGE, the circuit would be open and no voltage would appear across the load to be indicated by the voltmeter. Since the shunts do stay in the circuit when the meter terminals are switched to indicate

VOLTAGE, a slight error appears in the voltage readings because the 1,000 ohm meter resistance is no longer across the shunt, causing a little bit less current to flow around the circuit. To remedy this, a 1,000 ohm resistor is switched across the shunt resistor when the slide switch is in the VOLTAGE position.

With a pencil, draw in the 1,000 ohm resistor (brown-black-red) and complete the circuit in Figure 3-30 by observing the Schematic Diagram following Figure 3-30.

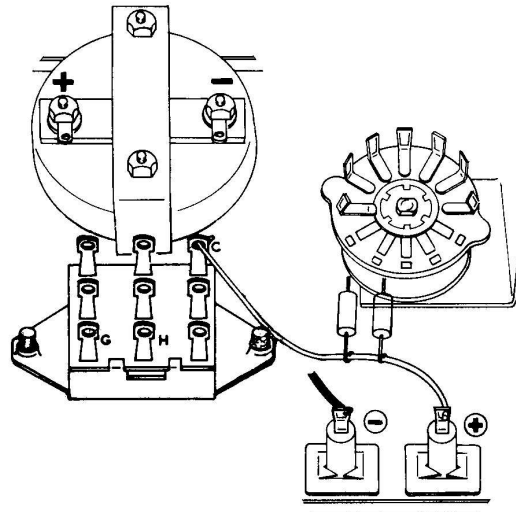
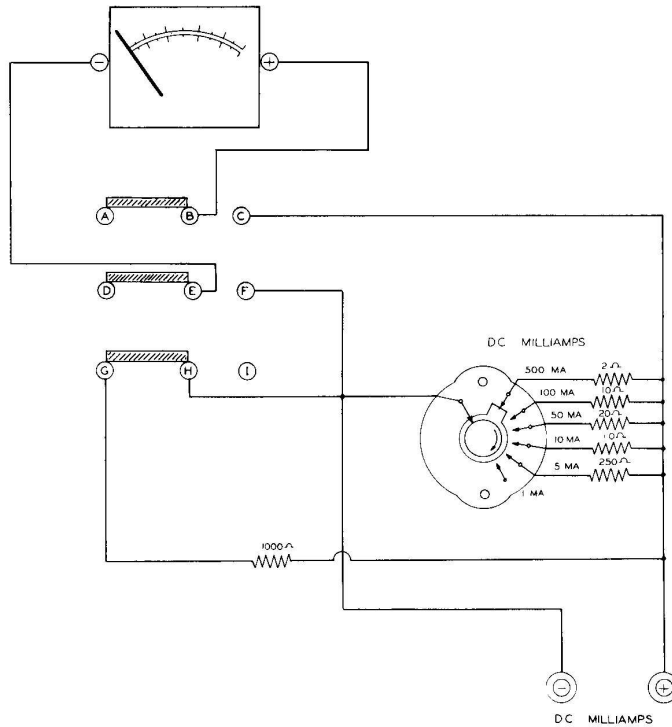

Figure 3-30



Check your penciled connections with Figure 3-30A in the Appendix and then wire in and solder the 1,000 ohm resistor circuit as shown in your corrected Figure 3-30.

THE A-C INDICATOR

Up to this point, the commercial meter is strictly a direct current instrument. If all electricity were of the direct current type, there would be no need for the a-c indicator. However, most homes and factories use an alternating type of current, for this type of current is more economical to transmit over many miles of wire. The type of alternating current (a-c) produced by power companies in the United States exhibits the following characteristics:

- A. The current starts at zero in one direction and increases in amount (determined by the load utilizing this current), then decreases to zero at which time it changes direction and again increases in amount (determined by the load), then decreases to zero again, repeating this cycle 60 times in one second.
- B. The time it takes the current to go first in one direction and then back again is always the same (1/60 of a second).

It is sometimes convenient to know if a-c voltage is present at a load and for this purpose an economical a-c indicating device has been added. The a-c indicating device consists of a neon bulb and resistor. If the neon bulb were connected directly to the 117 volt power line, it would burn out. Connecting a resistor of suitable value in series with the bulb limits the amount of current flowing through the bulb and protects it from burning out.

So that voltages from 90 to 500 volts a-c could be indicated safely, a resistor of 470,000 ohms is connected in series with the neon bulb.

- (✓) Connect the 470 K resistor (yellow-violet-yellow) to one of the red banana jacks next to the neon bulb. Attach one wire from the bulb to the other end of the resistor and the other wire from the bulb to the second red banana jack, Figure 3-31.

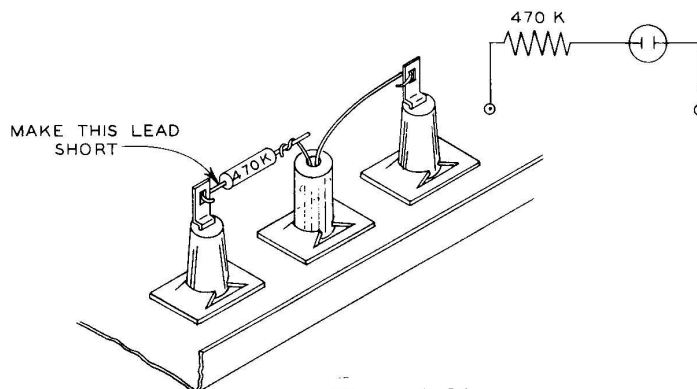

Figure 3-31

WARNING: UNDER NO CIRCUMSTANCES SHOULD YOU CONNECT THE METER TO AN A-C CIRCUIT.

This completes the construction of your commercial Volt-Ohm-Milliammeter (V-O-M Meter) and it may now be installed in its cabinet.

To test the a-c indicator, connect two of the test leads to the two red banana jacks and any voltage between 90 and 500 volts. **BE CAREFUL WHEN CONNECTING THE TEST LEADS DIRECTLY TO THE WALL OUTLET.** If you are not sure of a safe way to test the neon indicator, ask someone who is familiar with electricity to help you.

COMPLETE SCHEMATIC DIAGRAM OF THE V-O-M METER

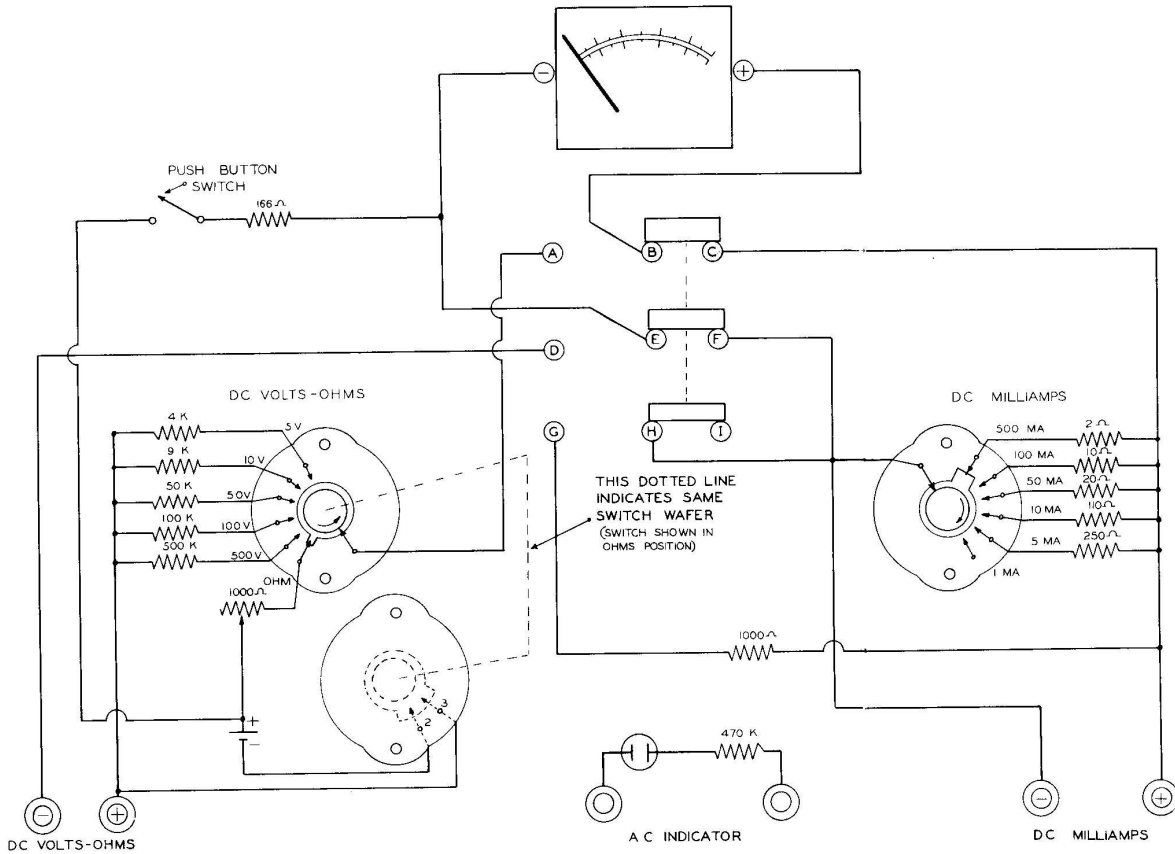

Figure 3-32

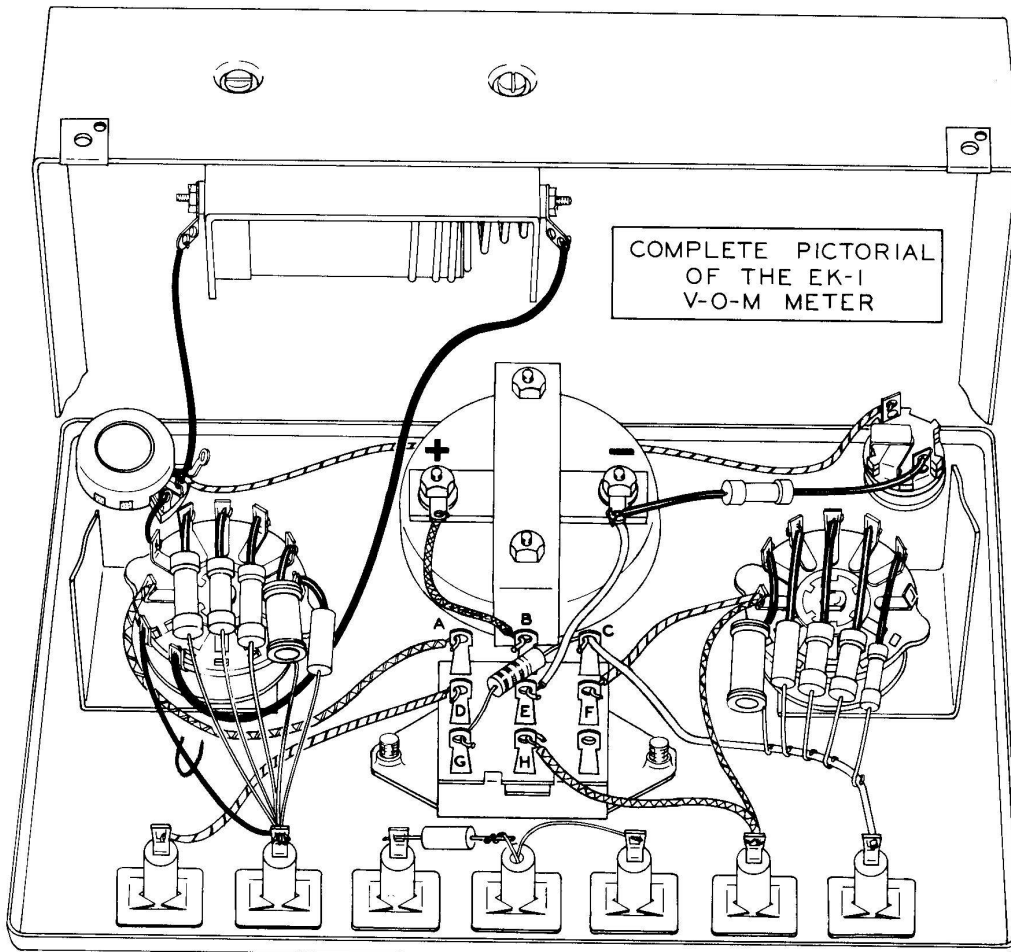
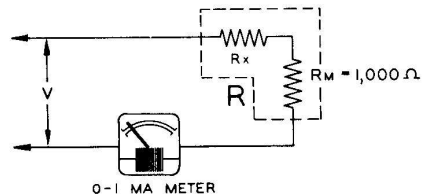

Figure 3-33

If you can answer all of the following questions correctly, it may be assumed that you understand the material in this chapter very well.

QUESTIONS FOR CHAPTER 3

1. Basically, most voltmeters are _____ calibrated in volts.
2. If a multiplier resistor of $4,000\ \Omega$ is connected to a meter with $1,000\ \Omega$ of resistance, what current will be flowing through the meter if the free resistor lead and meter terminal are connected to 4.5 volts?
3. What does the letter K usually stand for?
4. In the accompanying diagram, V equals 50 volts and the meter is a 0-1 ma meter. What is the resistance of the multiplier resistor R_x if the meter is indicating full scale?
5. Why is the ohms scale in reverse compared to all the other scales on the meter face?
6. Why is the switch contact for the 1 milliampere scale not used?



QUESTIONS FOR CHAPTER 3

1. Basically, most voltmeters are ammeters calibrated in volts.

2. If a multiplier resistor of $4,000 \Omega$ is connected to a meter with $1,000 \Omega$ of resistance, what current will be flowing through the meter if the free resistor lead and meter terminal are connected to 4.5 volts? Answer: $.9$ ma.

3. What does the letter K usually stand for? Answer: $1,000$.

4. In the following diagram, V equals 50 volts and the meter is a $0-1$ ma meter. What is the resistance of the multiplier resistor R_x if the meter is indicating full scale?

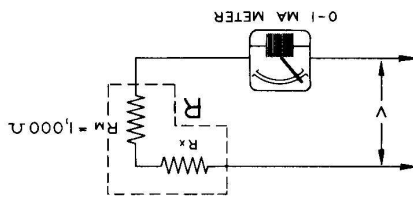

Answer: $49 K$.

5. Why is the ohms scale in reverse compared to all the other scales on the meter face? Answer: Increasing the resistance between the test leads from 0 to $20 K\Omega$ decreases the current from 1 milliampere to almost 0 , therefore, high current indicates low resistance and low current indicates high resistance, causing resistance indications to be in reverse to current indications.

6. Why is the switch contact for the 1 milliampere scale not used? Answer: The meter is basically a 1 milliampere movement and therefore no excess of current exists to be by-passed when measuring current of 1 milliampere or less.

CHAPTER 4
VERIFYING OHM'S LAW AND THE
D-C MAXIMUM POWER TRANSFER THEOREM

Before accurate measurements of any kind can be taken from the object under consideration, the limitations of the measuring device must be known. For example, in Figure 4-1, the more graduations the ruler has, the more accurate will be the reading obtained from the ruler.

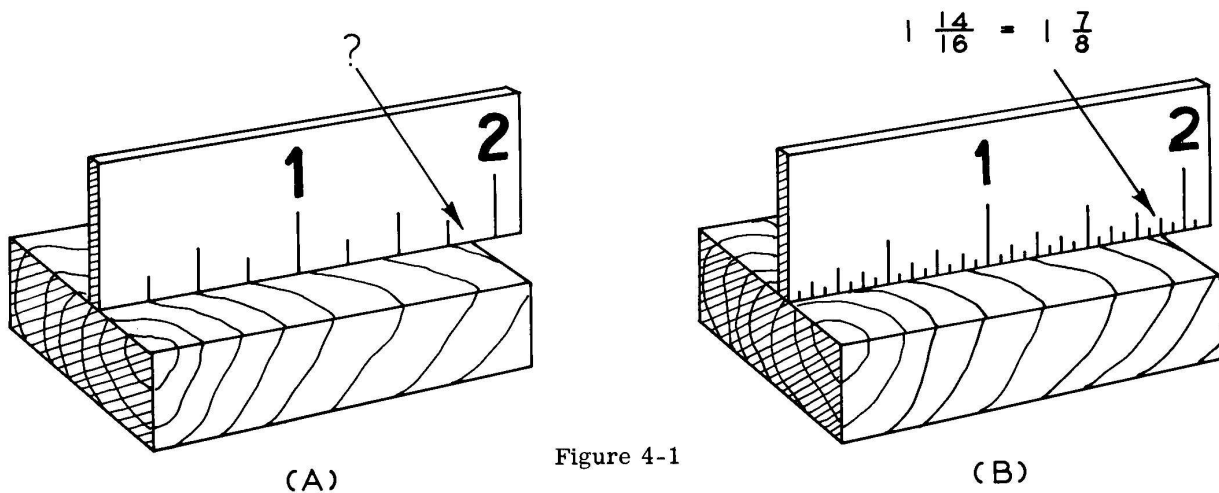

Figure 4-1

We can see that using the ruler in Figure 4-1 (A) results in a guess compared to ruler (B). The ruler in (A) is still better than no ruler at all and, knowing its limitations, it can be a very useful measuring device.

Similarly, the Volt-Ohm-Milliammeter just constructed would compare with ruler (A), while the Heathkit Vacuum Tube Volt-Ohmmeter would compare with ruler (B).

It is nice to have fine equipment but it is definitely not necessary when you are a novice. It is not necessary to buy an expensive casting rod to learn to fish, or to take driving lessons in the most expensive automobile in order to learn to drive. The Volt-Ohm-Milliammeter that you have just constructed was designed with the novice in mind and the limitations about to be pointed out exist with any meter, regardless of price, but to a lesser extent.

NOTE: IT IS GOOD PRACTICE TO SET THE RANGE SWITCHES TO THE HIGHEST SCALES BEFORE CONNECTIONS ARE MADE. AFTER CONNECTIONS ARE MADE, THE SWITCH IS THEN ROTATED TO THE APPROPRIATE SCALE. BY OBSERVING THIS PRACTICE, YOU WILL KEEP FROM BURNING OUT THE METER.

Construct the following circuit, Figure 4-2

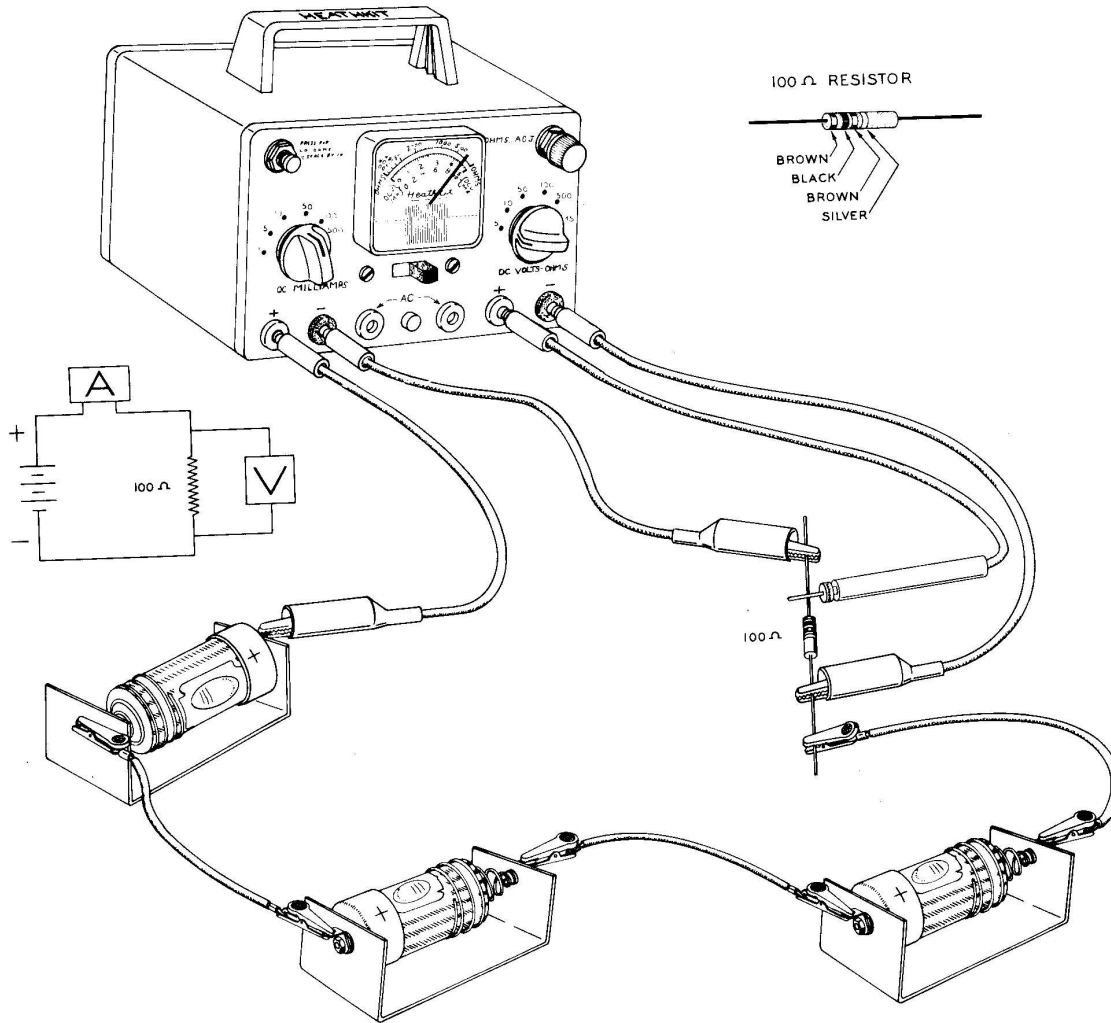

Figure 4-2

The voltage reading across the load is about 3.8 V and the current reading is about 41 milliamperes. Check these readings with your meter.

Move the slide switch to volt-ohms and rotate the current range switch, observing what happens to the voltage across the 100 ohm load. It should be noted that switching to lower current scales causes less voltage to appear across the 100 ohm load. This effect is due to the higher resistance shunts necessary for the lower current scales. Observe Figure 4-3 showing the shunt switching circuit.

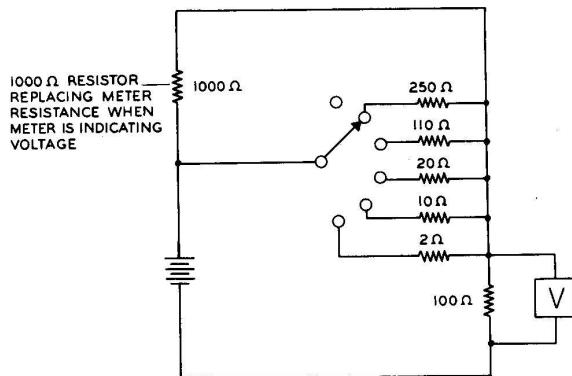

Figure 4-3

As the range switch is rotated from the 500 ma scale to the 1 ma scale, the various shunt resistances increase from 2 ohms to 1,000 ohms, thus decreasing the amount of current flowing around the circuit.

By Ohm's Law the 100Ω resistance is equal to the voltage across the resistance divided by the current through the resistance.

$$R = \frac{V}{I} \text{ or } 100 \Omega = \frac{V}{I}$$

If the current through the resistance decreases, the voltage must decrease proportionally. You have observed this happening and therefore you have verified the fact that connecting an ammeter into the circuit adds resistance to the circuit, thereby causing a lower value of current to flow around the circuit. Since the ammeter is only capable of indicating the actual current flowing through it and this current is less because of inserted ammeter resistance, the ammeter reading will naturally be less, causing an error. The amount of error is less, the more accurate and delicate the instrument.

The milliammeter insertion resistance offered by the EK-1 Meter will not cause excessive error in measuring electronic circuit currents if properly connected into this type of circuit.

Not only does the milliammeter present circuit error, but the voltmeter too has its problems. Voltmeter error is due to the fact that the voltmeter requires a small amount of current in order for it to function.

VERIFYING OHM'S LAW

With the circuit hookup of Figure 4-4, record in the Table below Figure 4-4 the current flowing through the load from the 50 ma scale and the voltage across the load from the 5 volt scale.

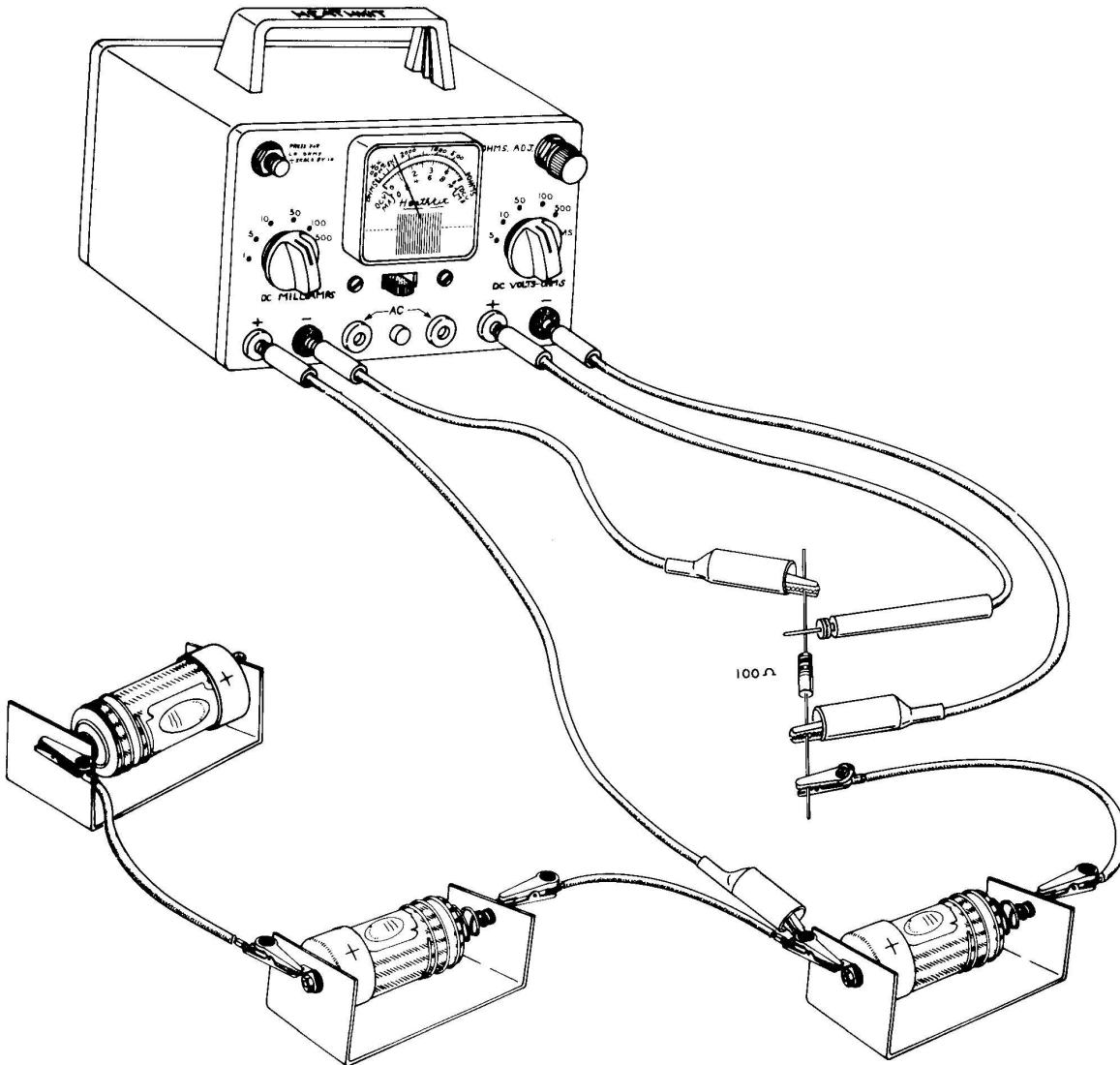

Figure 4-4

	BATTERY VOLTAGE	CURRENT THROUGH LOAD	VOLTAGE ACROSS LOAD	COMPUTED RESISTANCE
Example:	1.5 volts	11 ma	1.2 volts	109 ohms

Use Ohm's Law to compute the resistance. Remember to change milliamperes to amperes. Record the computed results in the Table on Page 92.

$$\text{Example: } R = \frac{V}{I} = \frac{1.2}{.011} = \frac{1200}{11} = 109 \text{ ohms}$$

Now measure the resistance of the load on the LO ohms scale as follows:

1. Disconnect one of the milliammeter leads so that no current flows through the load when checking resistance.

CAUTION: It is extremely important that no current other than that coming from the ohmmeter be flowing through the device when a resistance measurement is made, for if the voltage existing across the object is high enough, it could burn out your Meter. At any rate, a correct resistance reading cannot be obtained when current other than that coming from the ohmmeter circuit is flowing through the object under measurement.

2. Because the voltmeter leads are also used when measuring resistance, the ohmmeter leads in effect are already connected for measuring resistance.
3. Rotate the Volt-Ohms Range switch to OHMS and press the LO ohms button.
4. Read the resistance, remembering to divide by 10. Record this reading and the resistance as specified by the manufacturer in the box below.

Example:

MEASURED RESISTANCE (on LO ohms scale)	RESISTANCE AS SPECIFIED BY MANUFACTURER
96 ohms	100 ohms
120	

NOTE: The computed resistance in the example could have turned out less than 100 ohms, and also the measured resistance could have been greater than 100 ohms. Never be guided too rigorously by an example, but always enter the exact results even though they may seem in error. The point here is that the computed, measured and manufactured values should be in close agreement. If all three do not agree closely, make sure that human error did not enter. We mean by this that you may have read the wrong scale or your computation of resistance is wrong.

Rotate the Volt-Ohms selector switch back to 5 volts. **NEVER LEAVE THE VOLTS-OHMS SELECTOR SWITCH IN THE OHMS POSITION.** The reason for this is that you might forget the selector switch is in the OHMS position and try to make a voltage measurement; the result will be a burned out meter, as was previously explained.

Using the circuit of Figure 4-4, fill in the following boxes as before, using 3 volt and 4.5 volt connections, respectively.

BATTERY VOLTAGE	CURRENT THROUGH LOAD	VOLTAGE ACROSS LOAD	COMPUTED RESISTANCE
3 volts	13.02	2.5	1.1
4.5 volts	1.30	-	-

.0043 .5 12.0
11

MEASURED RESISTANCE	RESISTANCE AS SPECIFIED BY MANUFACTURER

To obtain further practice and verification of Ohm's Laws, construct the circuit as in Figure 4-5 and vary the control until the specified current in the box below is obtained in each case. At each current setting, make voltage and resistance measurements and complete the box.

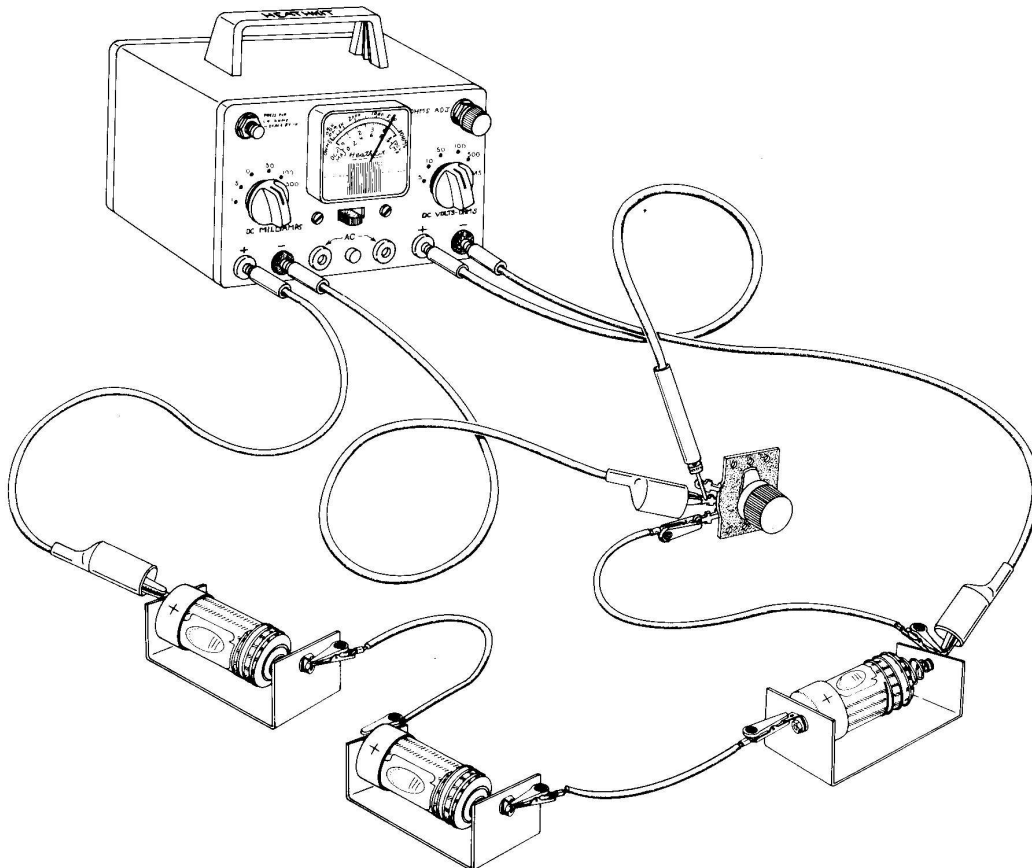

Figure 4-5

CURRENT THROUGH LOAD	VOLTAGE ACROSS LOAD	COMPUTED RESISTANCE	MEASURED RESISTANCE
20 ma	3.8	.019	20 ⁰
30 ma	3.5	.028	123
40 ma	3.2	.0355	90
50 ma	2.95	.059	70

If the computed and measured resistance values compare favorably, you have successfully demonstrated the validity of Ohm's Law.

ELECTRICAL POWER

The unit for electrical power is the "watt", named in honor of James Watt, the inventor of the steam engine. The amount of power (in watts) consumed by an electrical load is equal to the current (in amperes) flowing through the load times the electrical pressure (in volts) that exists across the load.

Mathematically stated:

$$P = VI$$

where

P = power in watts
V = pressure in volts
I = current in amperes

Problem: What is the current flowing through the lamp and the power consumed by the lamp in the circuit of Figure 4-6?

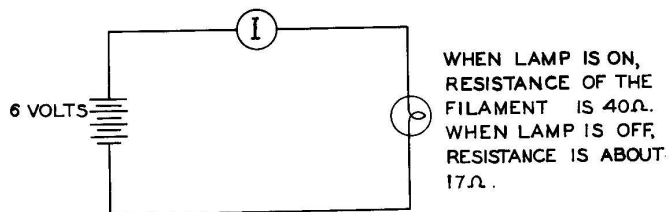

Figure 4-6

Solution: $I = \frac{V}{R}$

$$I = \frac{6 \text{ volts}}{40 \text{ ohms}}$$

$$I = 0.15 \text{ amperes}$$

$$P = IV$$

$$P = (.15 \text{ amperes}) \times (6 \text{ volts})$$

$$P = 0.90 \text{ watts (consumed by the lamp)}$$

Problem: Three cells are connected in series with a $120\ \Omega$ resistor and variable resistor. The variable resistor is adjusted until 1.25 volts appear across it and a current of 27 ma flows through it. Calculate the resistance of the variable resistance and the power consumed by both resistors (see Figure 4-7).

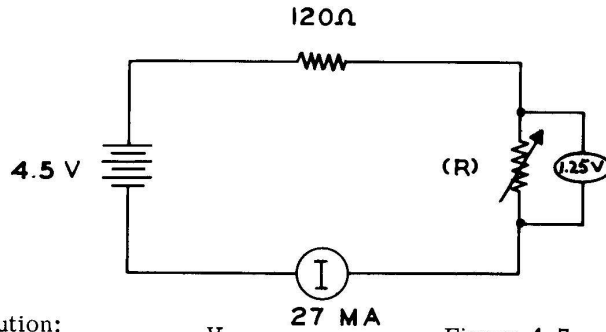

Solution:

$$R = \frac{V}{I}$$

Figure 4-7

$$R = \frac{1.25}{.027} = 46\ \Omega \text{ (resistance of variable resistor)}$$

$$P_{(R)} = IV = .027 \times 1.25 = .0338$$

$$P_{(R)} = .034 \text{ watts (consumed by variable resistor)}$$

$$P_{(120\ \Omega)} = IV$$

Since $V = IR$ (Ohm's Law) we can replace V with IR .

$$P_{(120\ \Omega)} = I \times IR$$

$$P_{(120\ \Omega)} = .027 \times .027 \times 120$$

$$P_{(120\ \Omega)} = .0875 \text{ watts (consumed by fixed resistance)}$$

THE D-C MAXIMUM POWER TRANSFER THEOREM

Theorem: Maximum power output is obtained from a d-c voltage source when the resistance of the load is equal to the internal resistance of the voltage source.

Theory: Consider the following circuit, Figure 4-8.

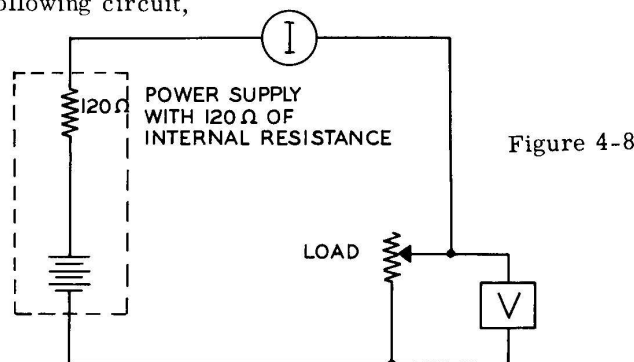

Figure 4-8

Since the internal resistance of cells is in the order of 0.2 ohms, the load resistance would have to vary below and above this very low resistance in order to demonstrate the experiment. Also, the total circuit resistance would be so low that 5 or 10 amperes would be flowing around the circuit. To bring the experiment up to the level of your equipment, it is only necessary to increase the internal resistance of the cells. This is done by inserting 120 ohms of resistance in series with the cells, considering this as the internal resistance of the cells. Since the 0.2 ohm of actual cell resistance is insignificant next to the 120 ohms of added resistance, we simply neglect it.

By varying the load resistance from zero to 250 ohms and calculating the power consumed in the load at various intervals of load resistance, a load resistance close to 120 ohms will be found to consume the maximum amount of power. Load resistances below or above this value will not consume as much power. A line graph is used to illustrate this effect.

Procedure: Construct the circuit of Figure 4-9.

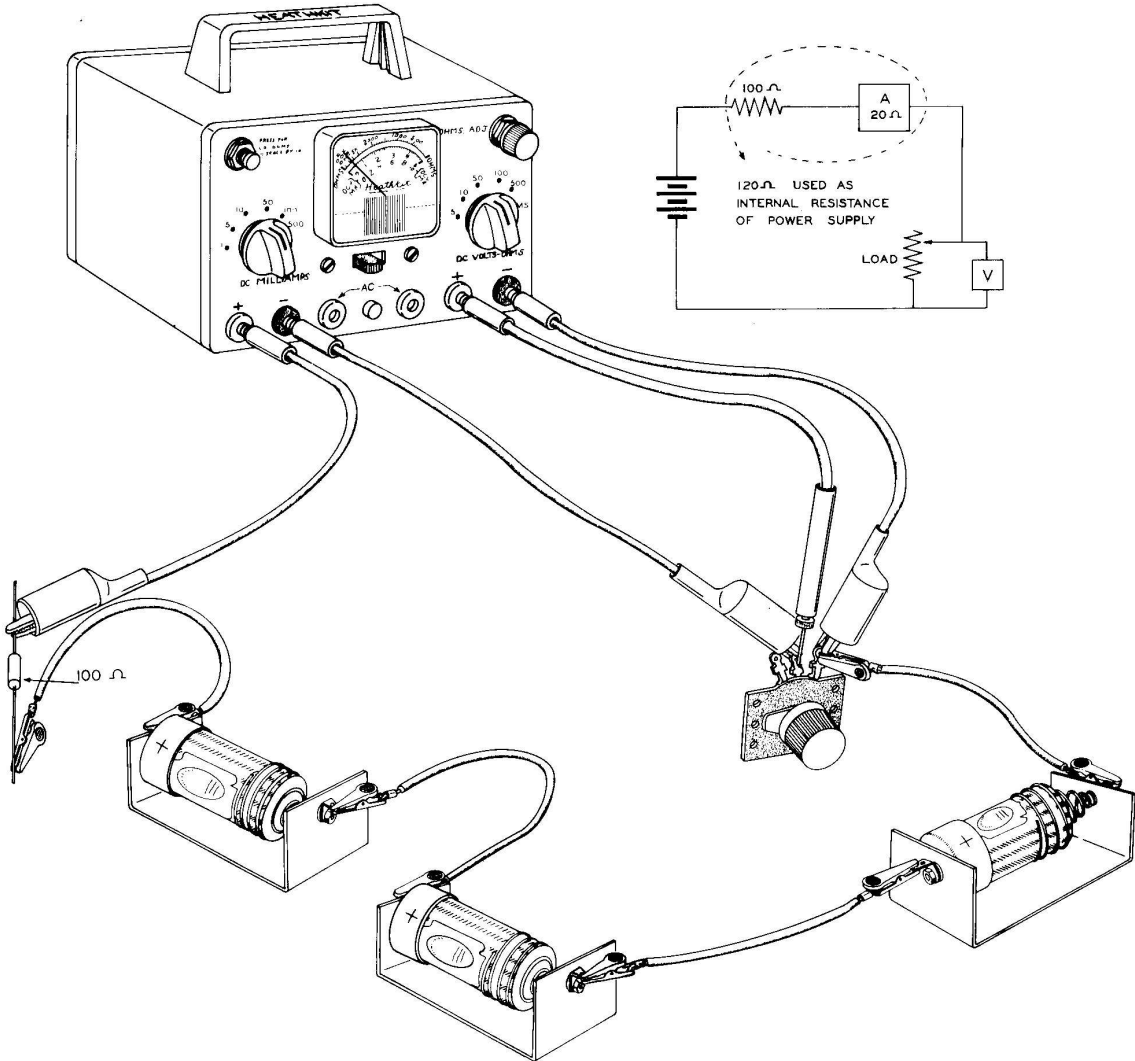

Figure 4-9

1. From the data of voltage and current, calculate and tabulate in the table on Page 98, the values of load resistance $R = \frac{V}{I}$ and power consumed ($P = VI$).
2. On the graph paper provided, Figure 4-11, plot the resistance and power values as calculated and draw a curved line joining these points (see Figure 4-10).
3. From the curve, obtain the value of load resistance corresponding to maximum load power and compare this value with the 120 ohm internal resistance of the power source (see Figure 4-10).

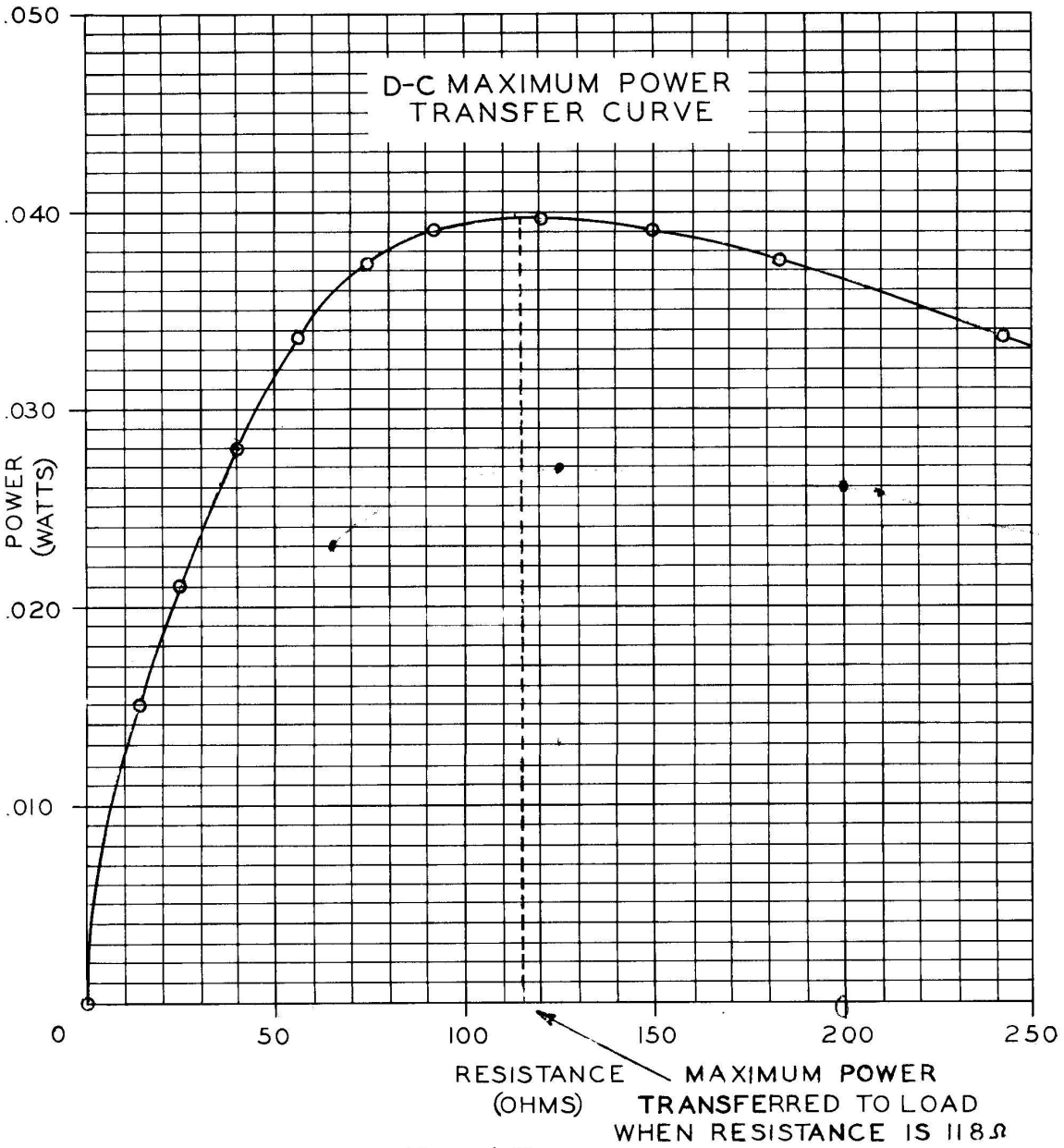

Figure 4-10

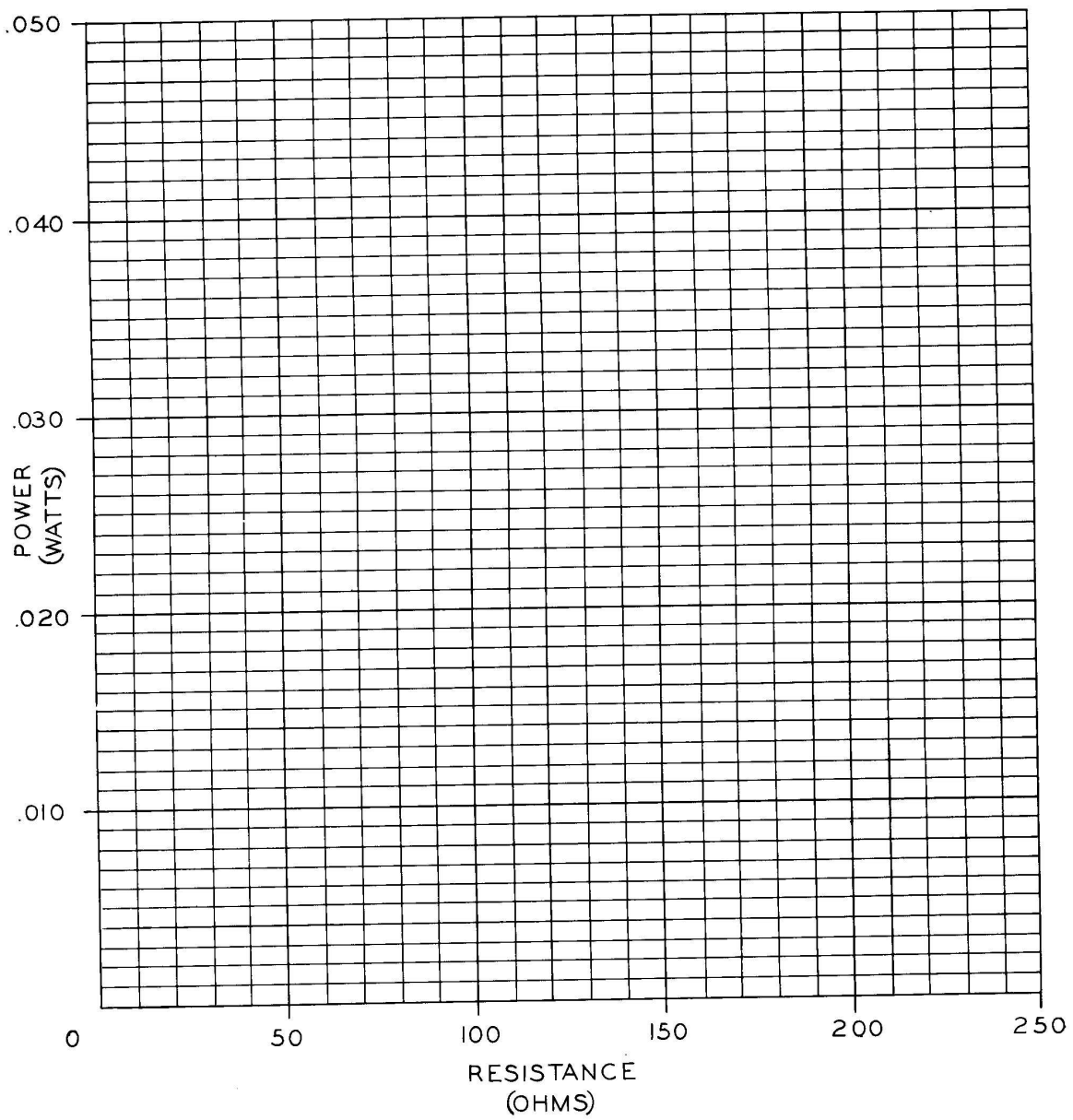

Figure 4-11

If the load resistance corresponding to maximum load power is fairly close to the internal resistance (120 ohms), you have verified the D-C Maximum Power Transfer Theorem.

CHAPTER 5

CHECKING ELECTRICAL APPLIANCE AND AUTOMOBILE CIRCUITS

Continuity Testing

The word continuity means "quality or state of being continuous". Electrical circuits are continuous. The word circuit implies that the electrons have a continuous path to follow. The ohmmeter is usually used when checking the continuity of a circuit or device. When the ohmmeter leads are held together, current flows through the ohmmeter circuit, Figure 5-1.

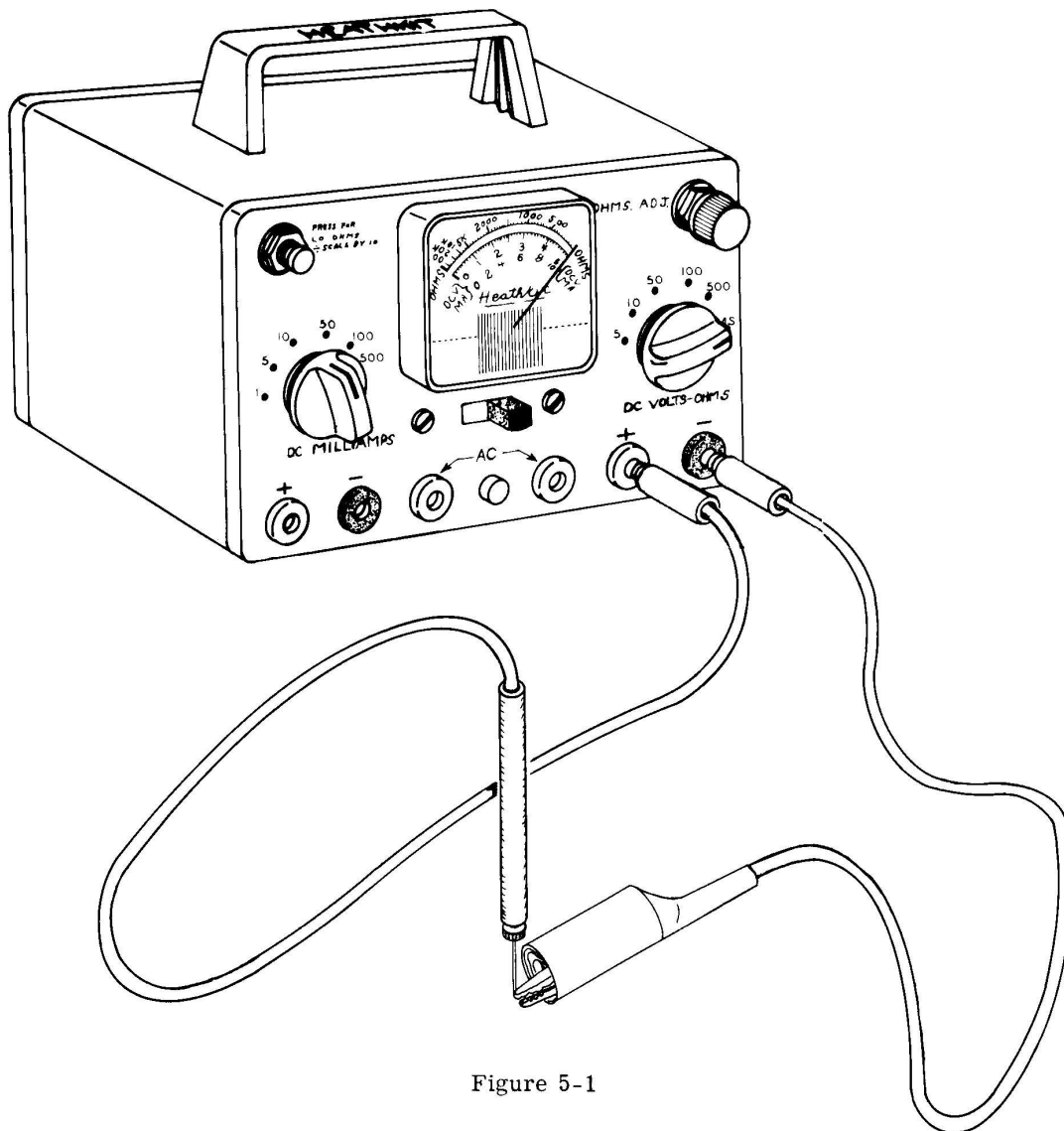

Figure 5-1

This current is indicated by the 0-1 milliammeter for the pointer swings across the dial to full scale. The meter in effect indicates continuity of the ohmmeter circuit. When the leads are separated, thus creating a break in the circuit, the continuity of the circuit is broken. The meter again indicates this condition, for the pointer is now at its rest position.

If the ohmmeter leads are connected to a lamp that is not burned out, the meter will indicate current flowing through the filament of the lamp, thus indicating the "continuity" of the filament.

Using your ohmmeter, check the continuity of the filament of the #47 lamp and any other lamp in the house, as shown in Figure 5-2.

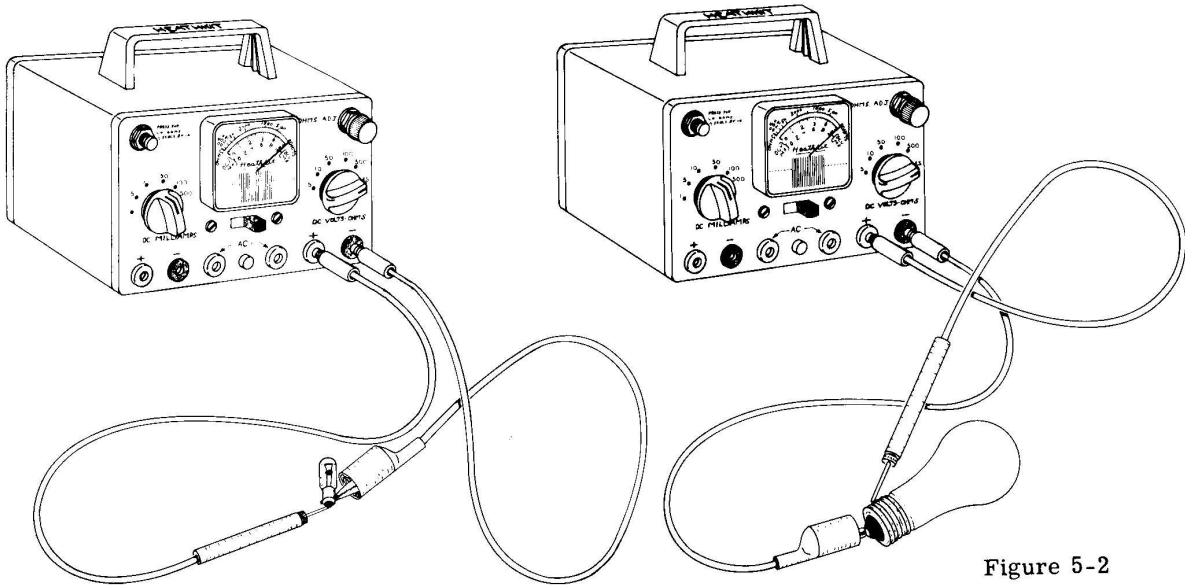

Figure 5-2

If the filament is burned out, the pointer will stay at its rest position.

The voltage must always be removed from the device before measuring its continuity, for continuity testing is merely the measuring of the resistance of the device under test and you will recall that when measuring resistance, no current other than that coming from the ohmmeter must be flowing through the device.

THE FOLLOWING DIAGRAMS SHOW HOW TO CHECK THE CONTINUITY OF VARIOUS APPLIANCES OR DEVICES

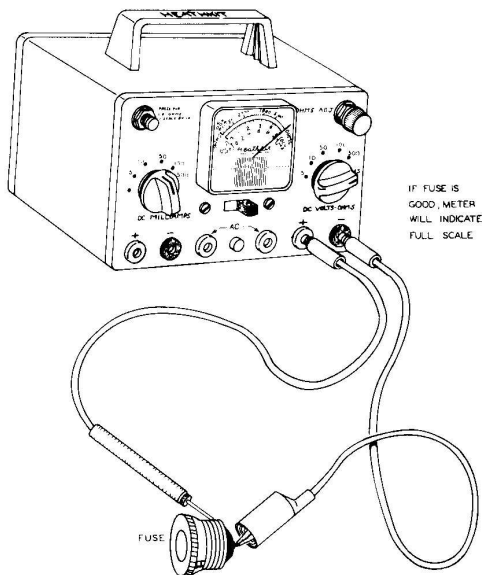

Figure 5-3A

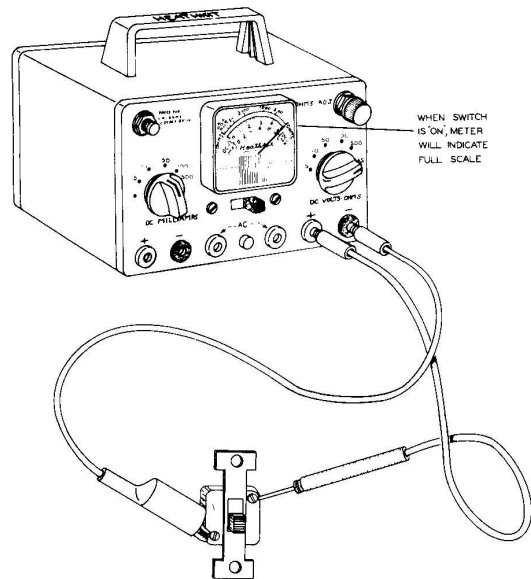

Figure 5-3B

IF THE FOLLOWING APPLIANCES ARE GOOD, THE METER SHOULD INDICATE NEAR FULL SCALE.

Flatiron and Cord

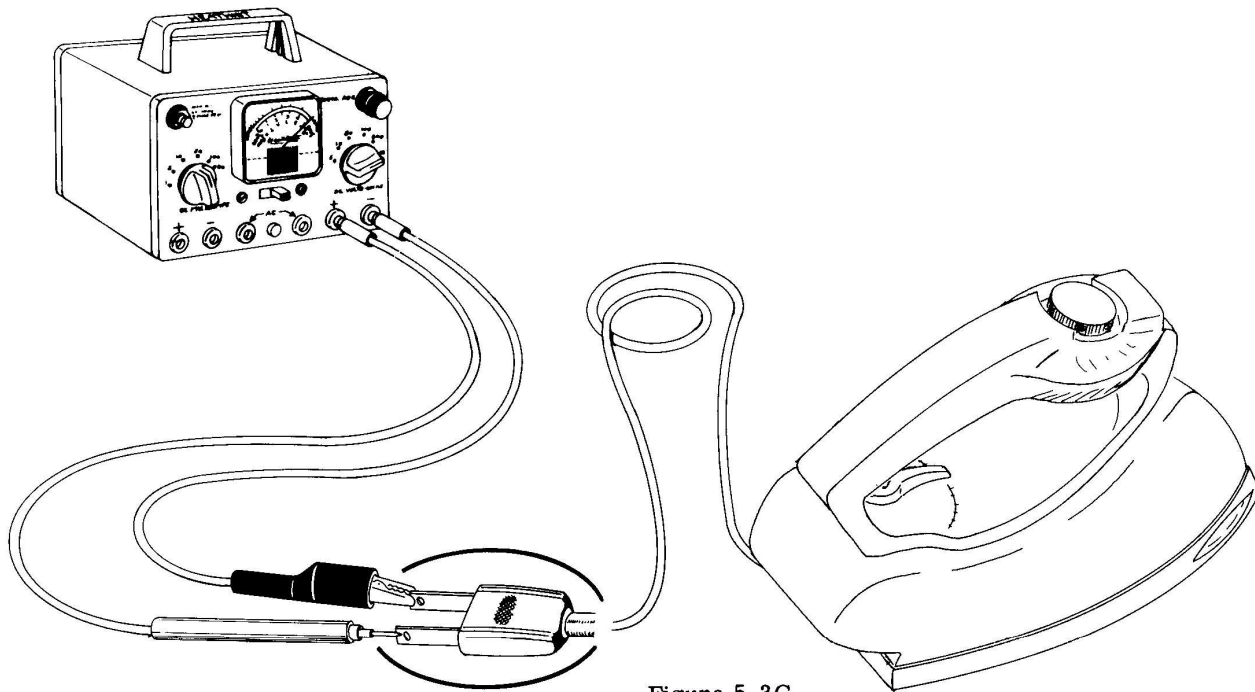

Figure 5-3C

Toaster and Cord

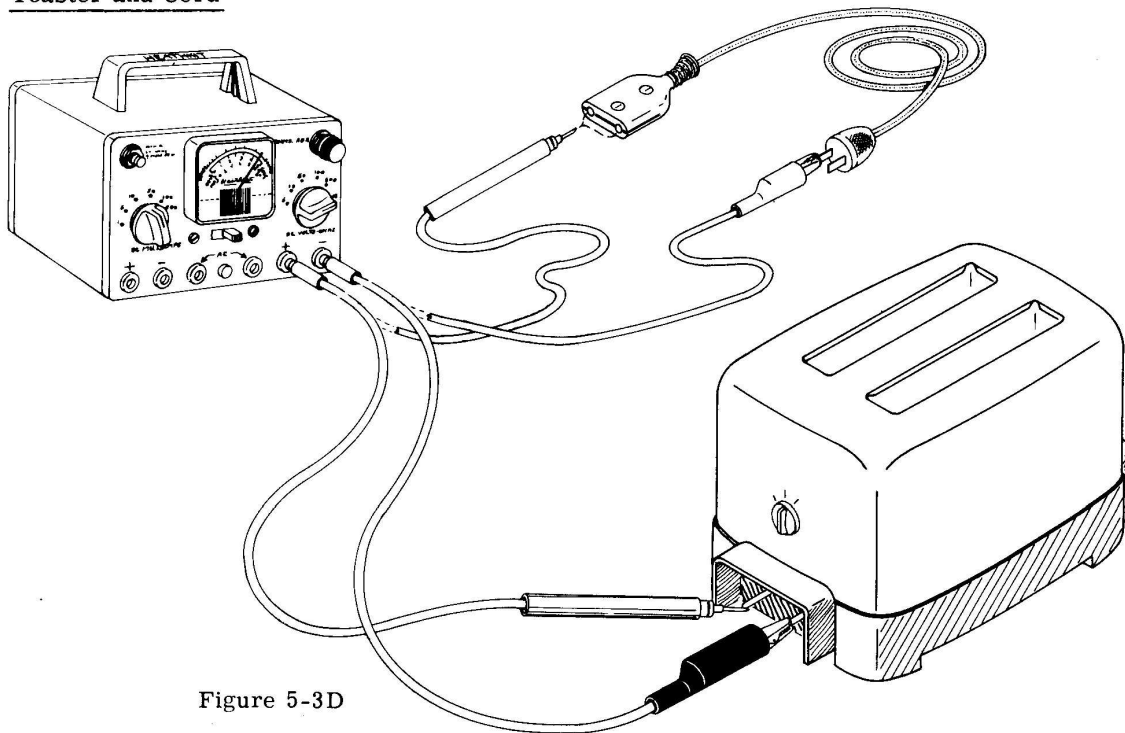

Figure 5-3D

Waffle Iron

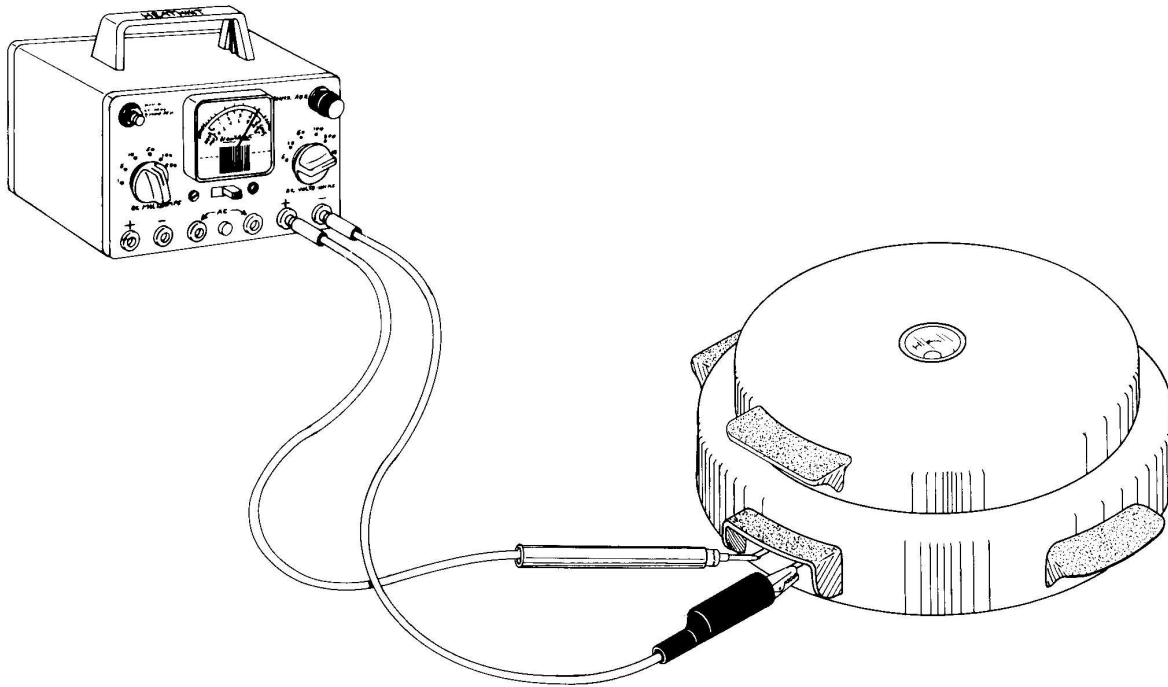

Figure 5-3E

Heating Pad

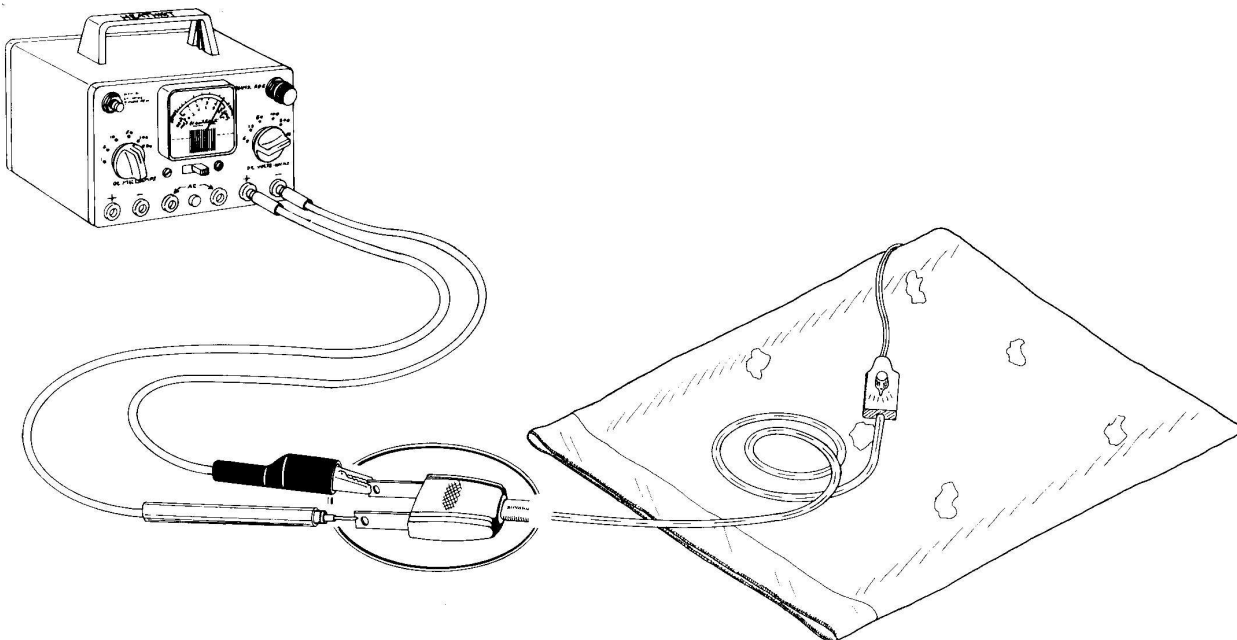

Figure 5-3 F

Clock

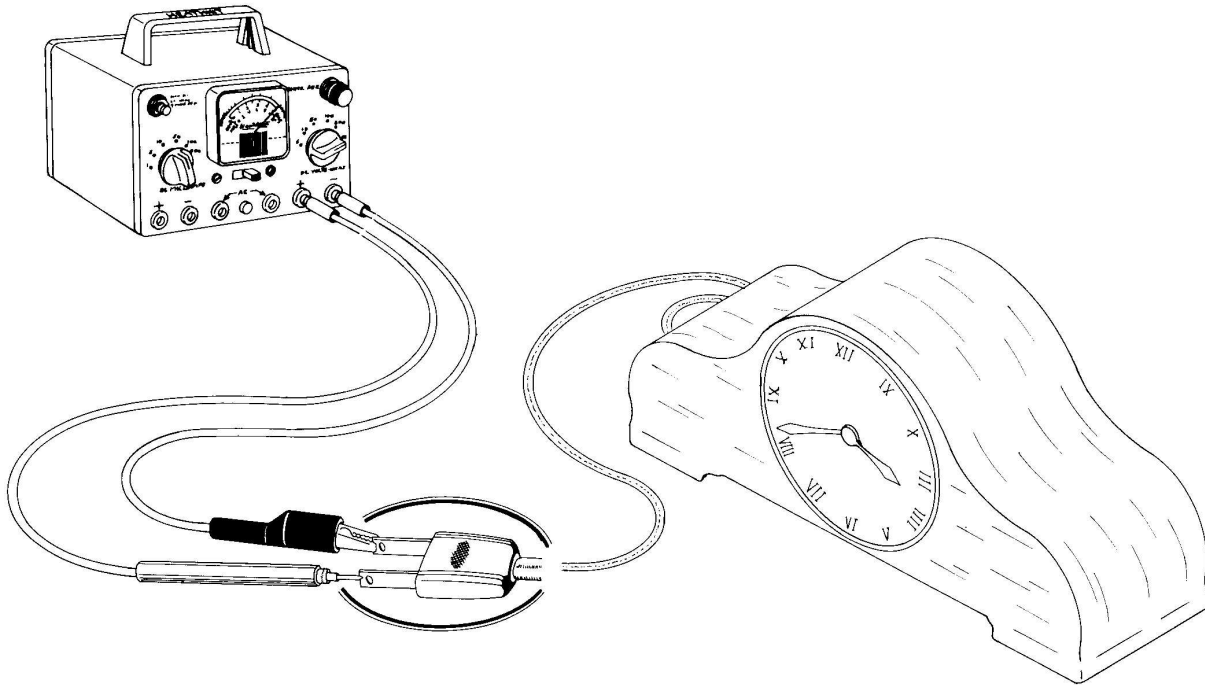

Figure 5-3G

Fan

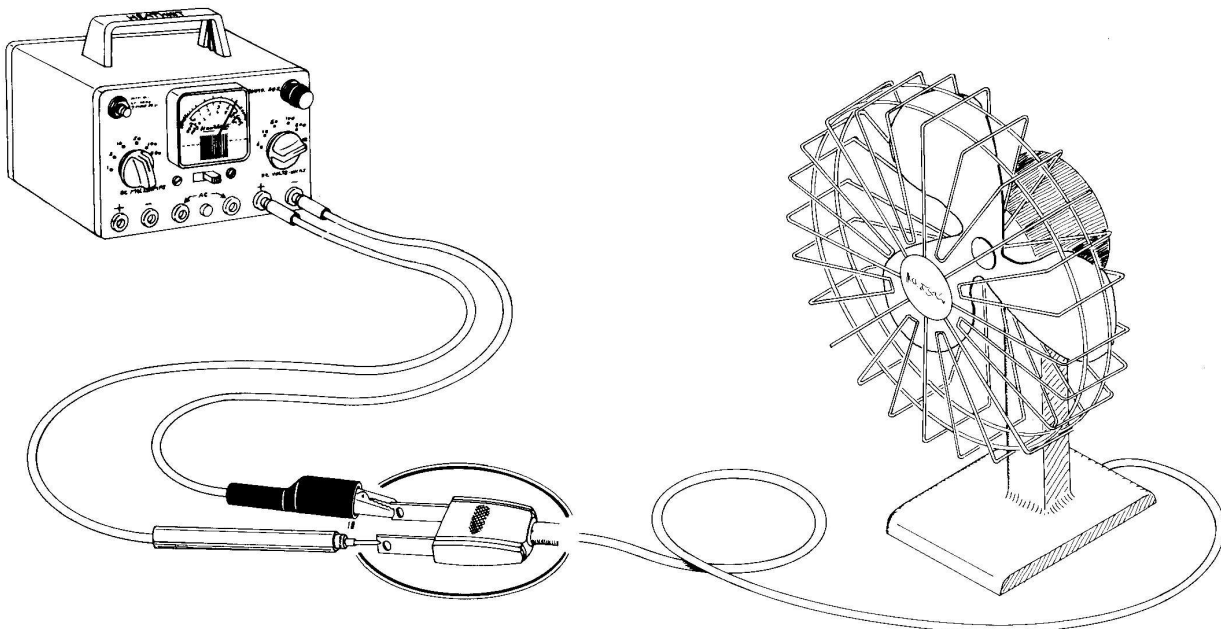

Figure 5-3H

Vacuum Cleaner

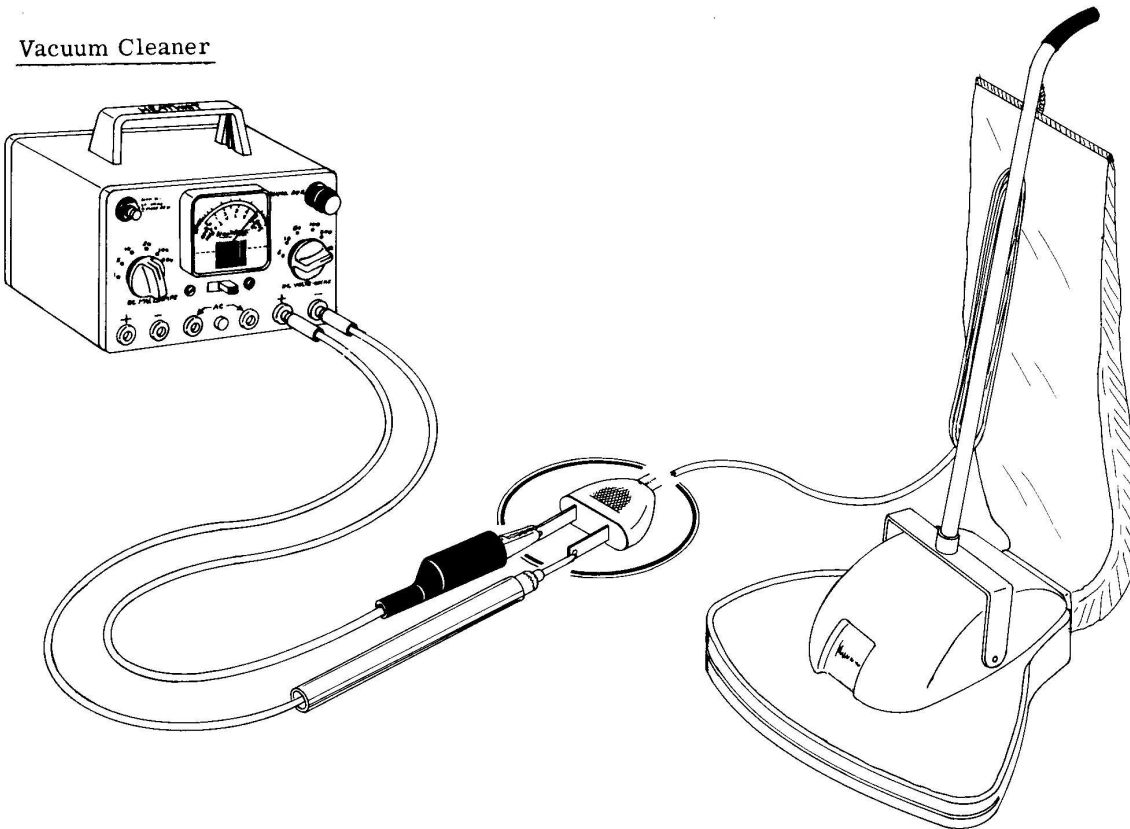

Figure 5-3I

Voltage Tests

It is sometimes helpful to know if voltage is present at the device or wall outlet. The AC indicator is used for this purpose. The volts-ohms test leads are plugged into the two red AC banana jacks so that the neon bulb can function.

For example, in checking voltage at the end of the flatiron cord, we connect the two AC indicator test leads to the end of the cord that plugs into the iron, and then plug the cord into a wall outlet. See Figure 5-4.

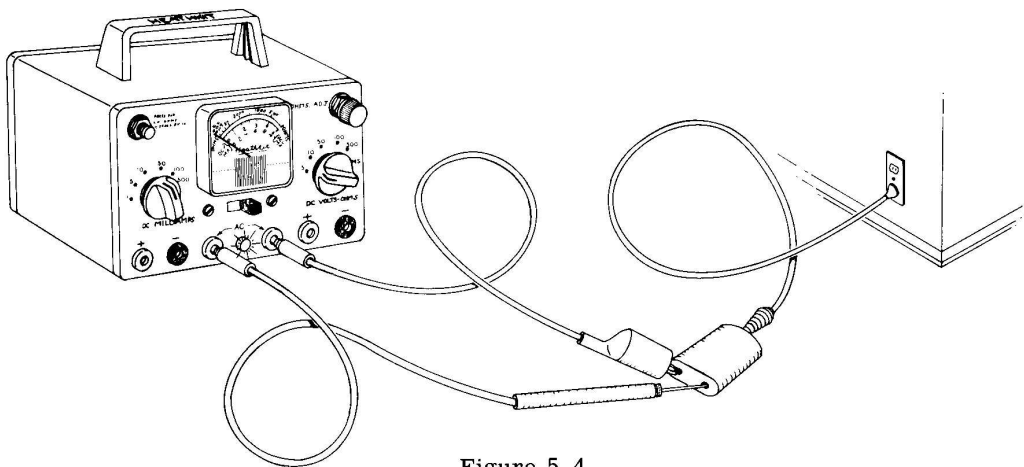

Figure 5-4

If the cord is good, the neon bulb will glow, indicating the presence of a-c voltage.

The Automobile Storage Battery

To check battery voltages in the automobile, Figure 5-5, use the 10 volt scale if the automobile contains a 6-volt battery, or the 50 volt scale if the automobile contains a 12-volt battery. Either the positive or negative pole of the battery (depending on the make of automobile) will be fastened to the frame. The frame acts as a return wire to the electrical source.

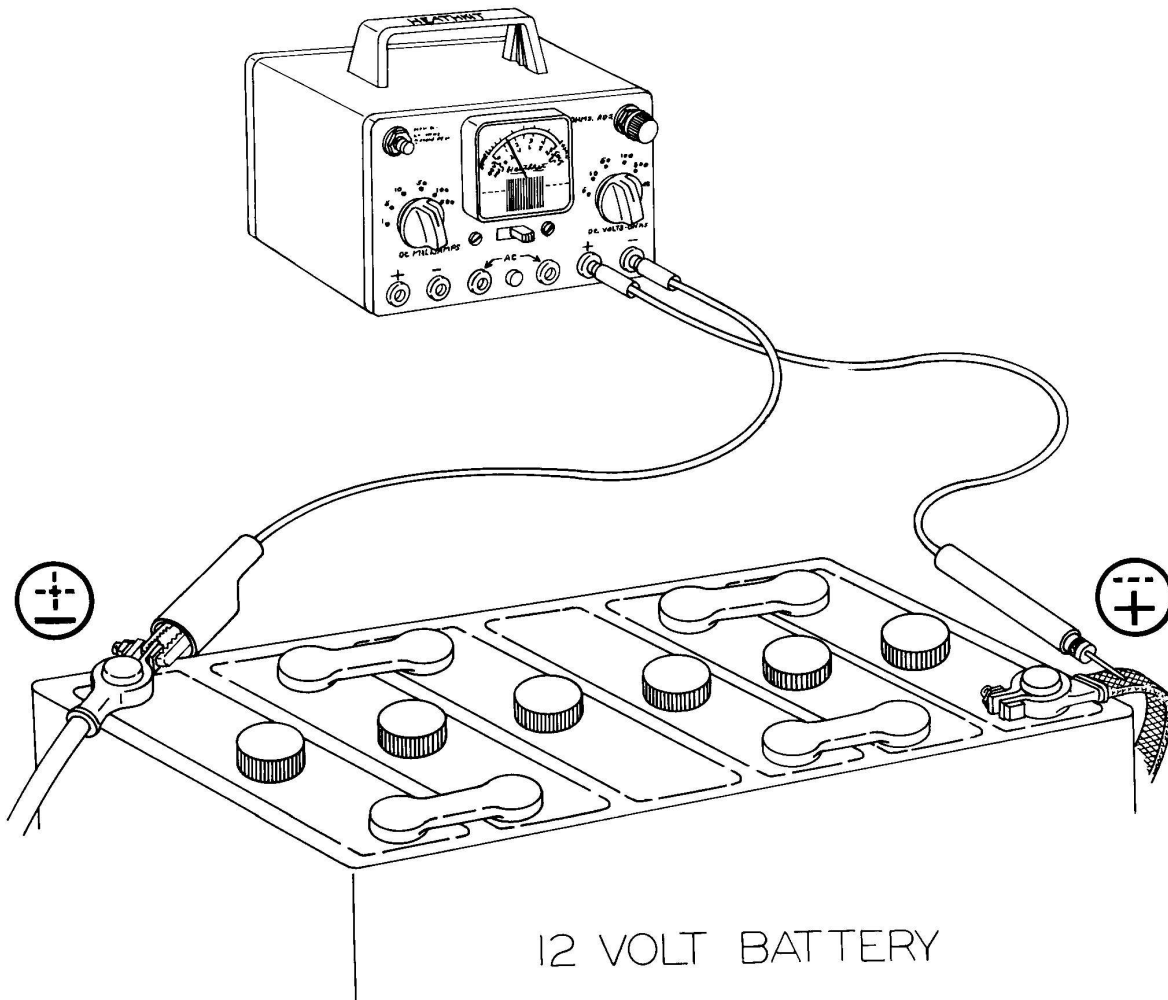

Figure 5-5

The automobile storage battery is made from 2-volt cells connected in series. The 6-volt battery has three such cells while the 12-volt battery contains six such cells. The voltage of each cell can be checked on the 5 volt scale by holding the test leads on the cell terminals as shown in Figure 5-6.

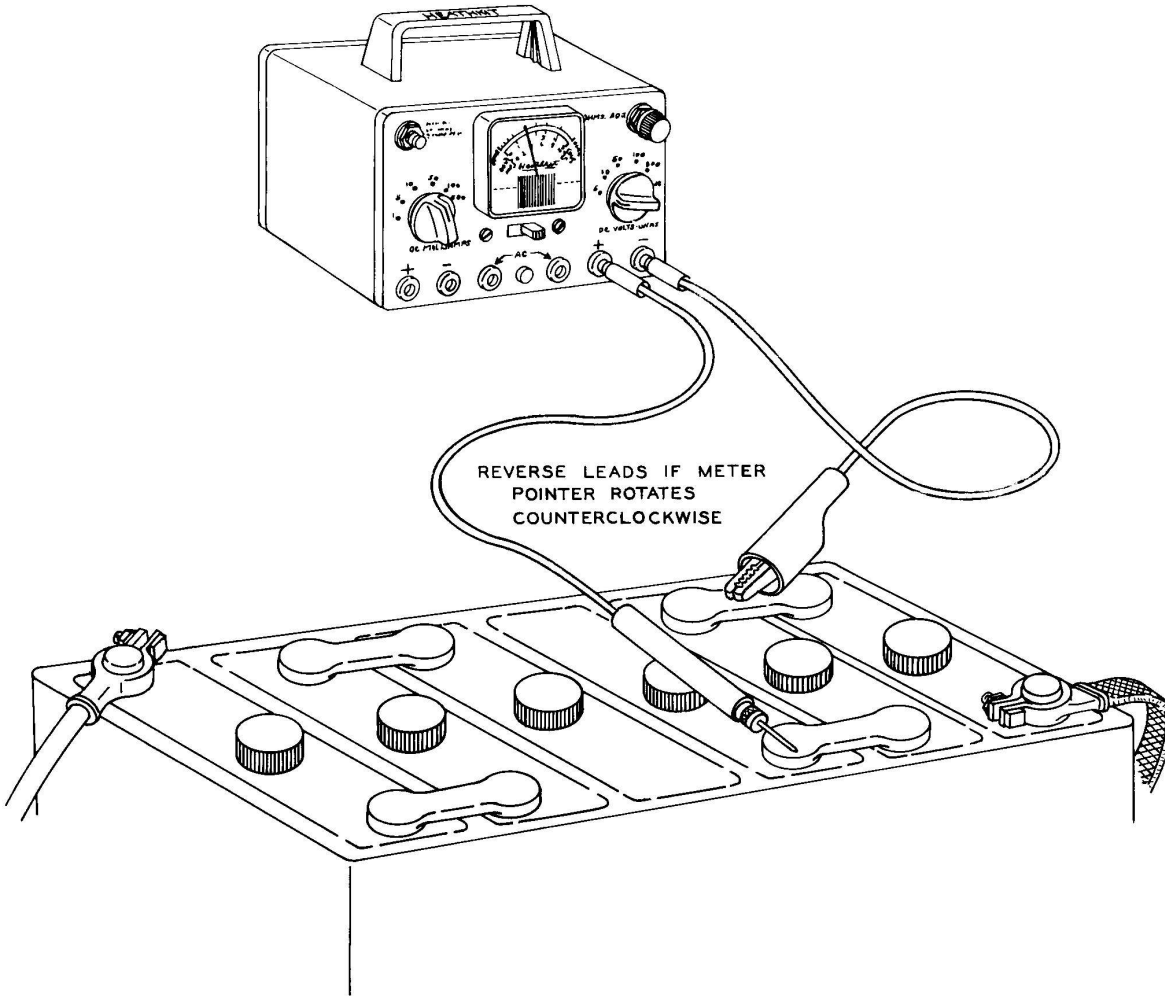

Figure 5-6

To check the voltage at the dome lamp of an automobile with a 12-volt battery, the black (negative) test lead is connected to a convenient place on the frame, and after removing the lamp, the red (positive) test lead is held at the center of the lamp socket. The voltage is then read on the 50 volt scale. If the pointer rotates in the wrong direction, reverse the test leads at the meter (that is, put the red test lead in the black banana jack and the black test lead in the red banana jack).

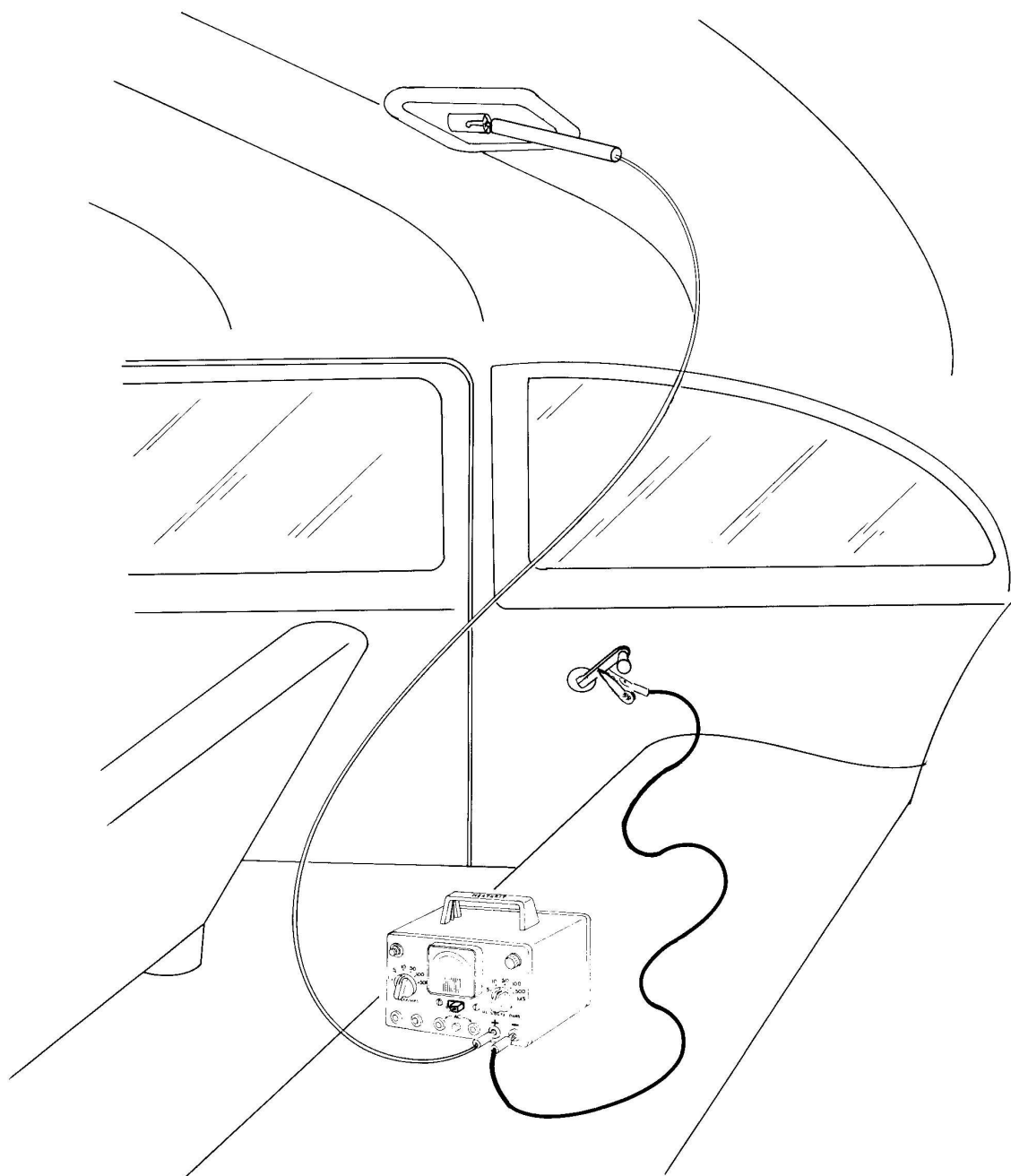

Figure 5-7

The Hydraulic Stop Light Switch

Voltage will be present across the switch terminals when the switch is OFF, Figure 5-8. When the brake pedal is pressed, the switch turns ON, causing the voltage across the terminals to become zero. The ignition switch should be ON when the switch is checked.

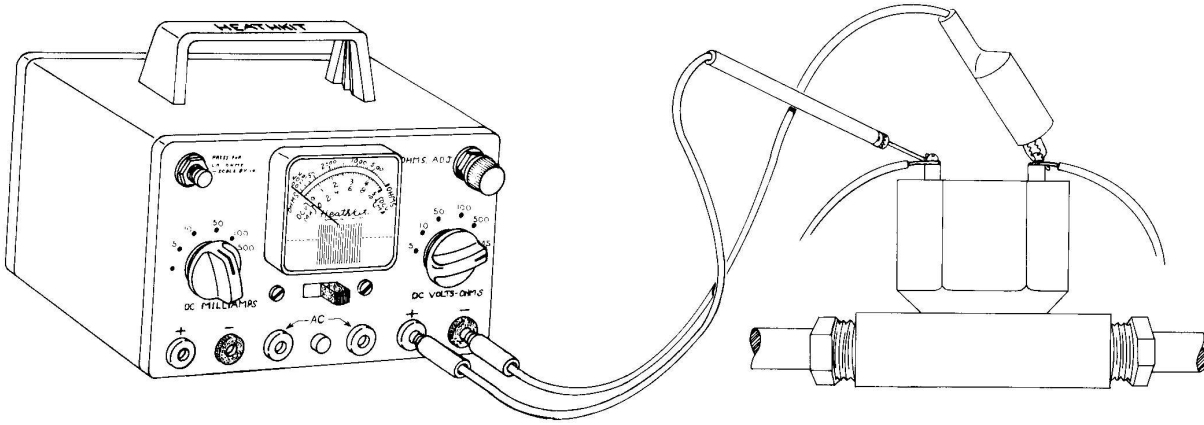

Figure 5-8

Fuses and Lamps Check by Continuity

Using the ohmmeter circuit, automobile fuses and lamps can be checked for continuity.

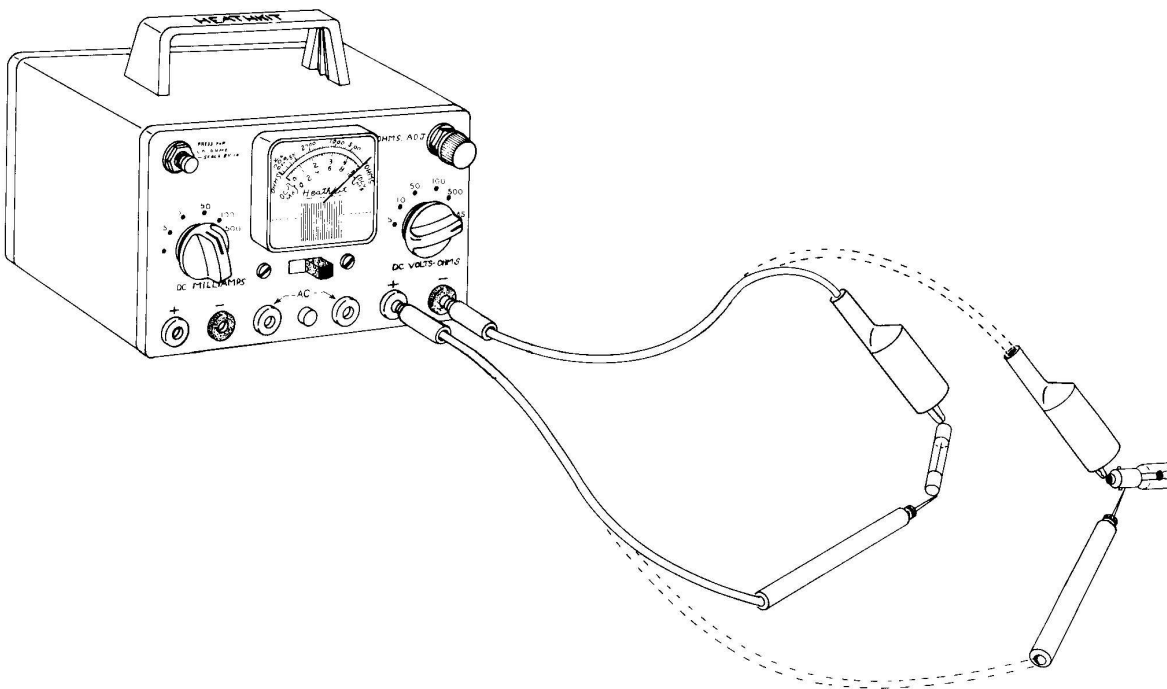

Figure 5-9

APPENDIX

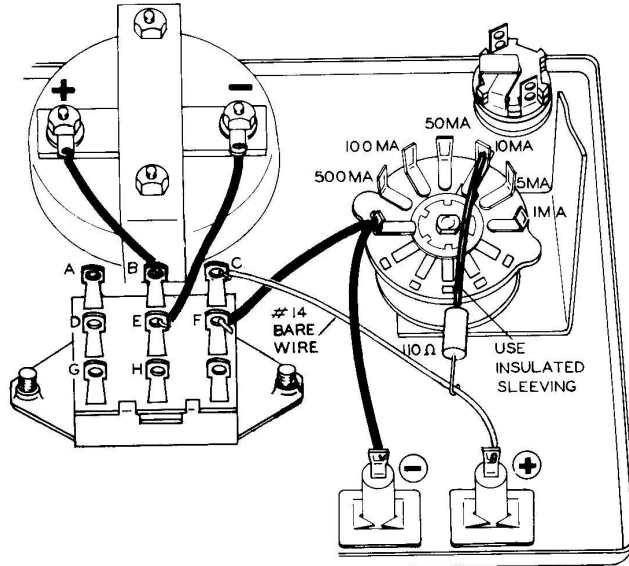

Figure 3-19A

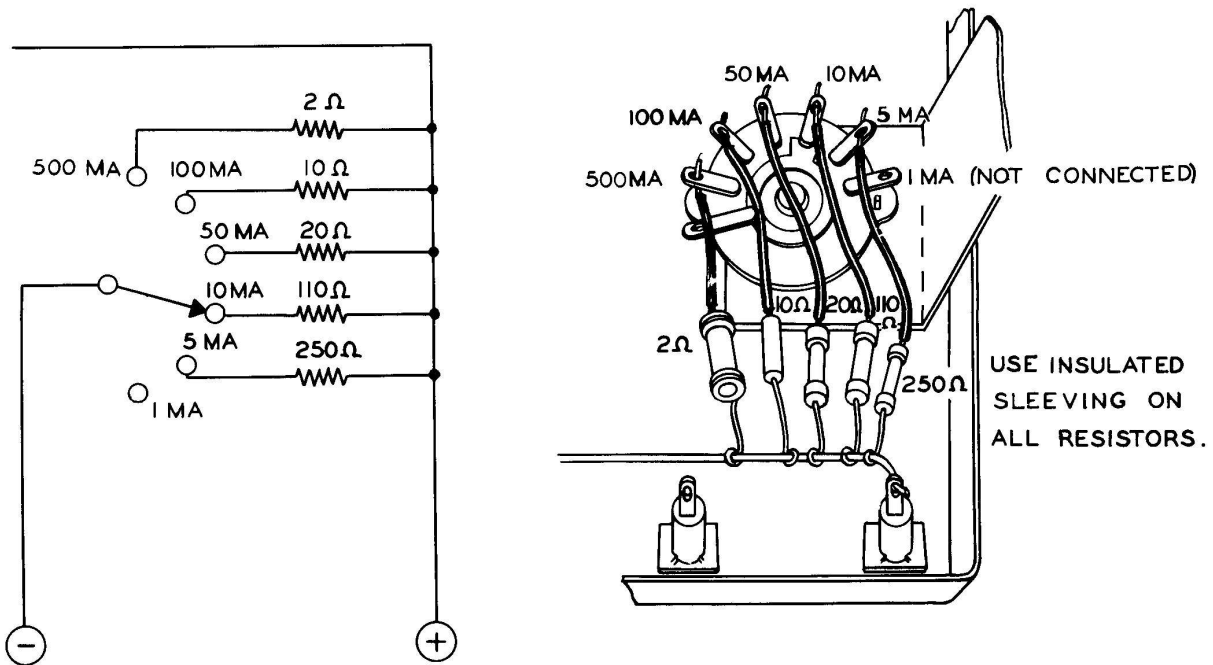

Figure 3-21A

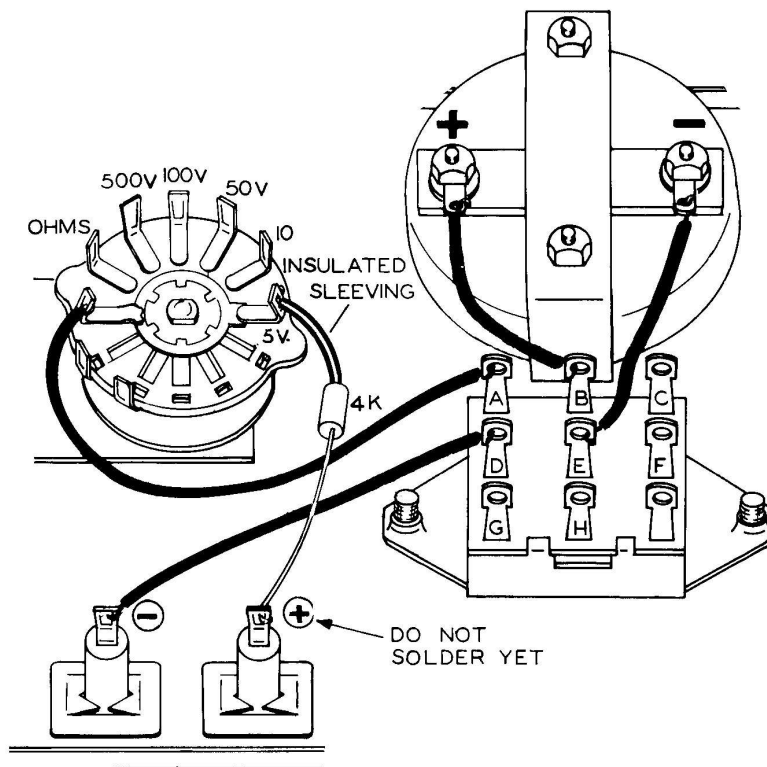

Figure 3-22A

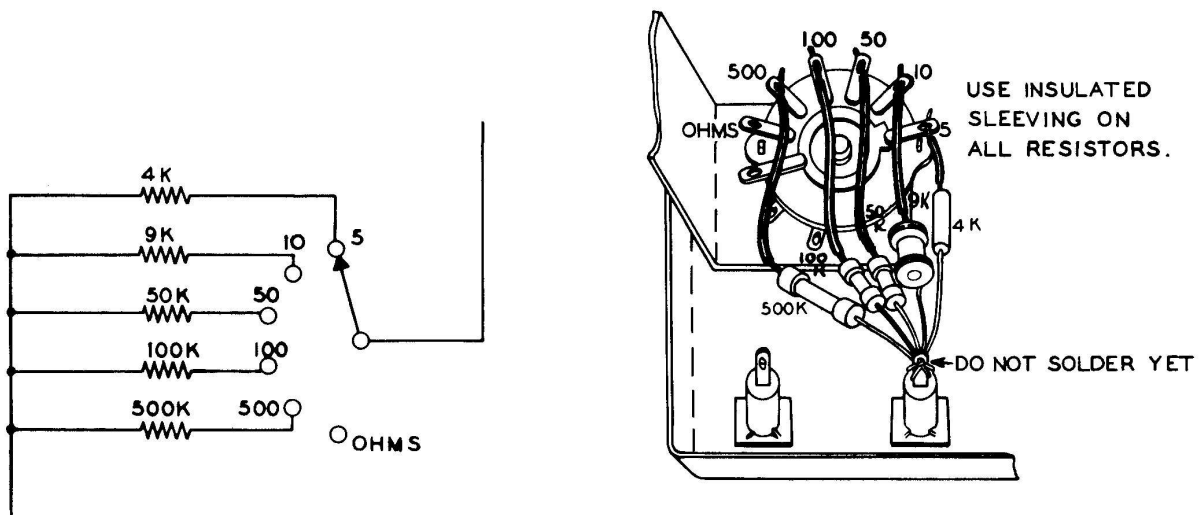

Figure 3-24A

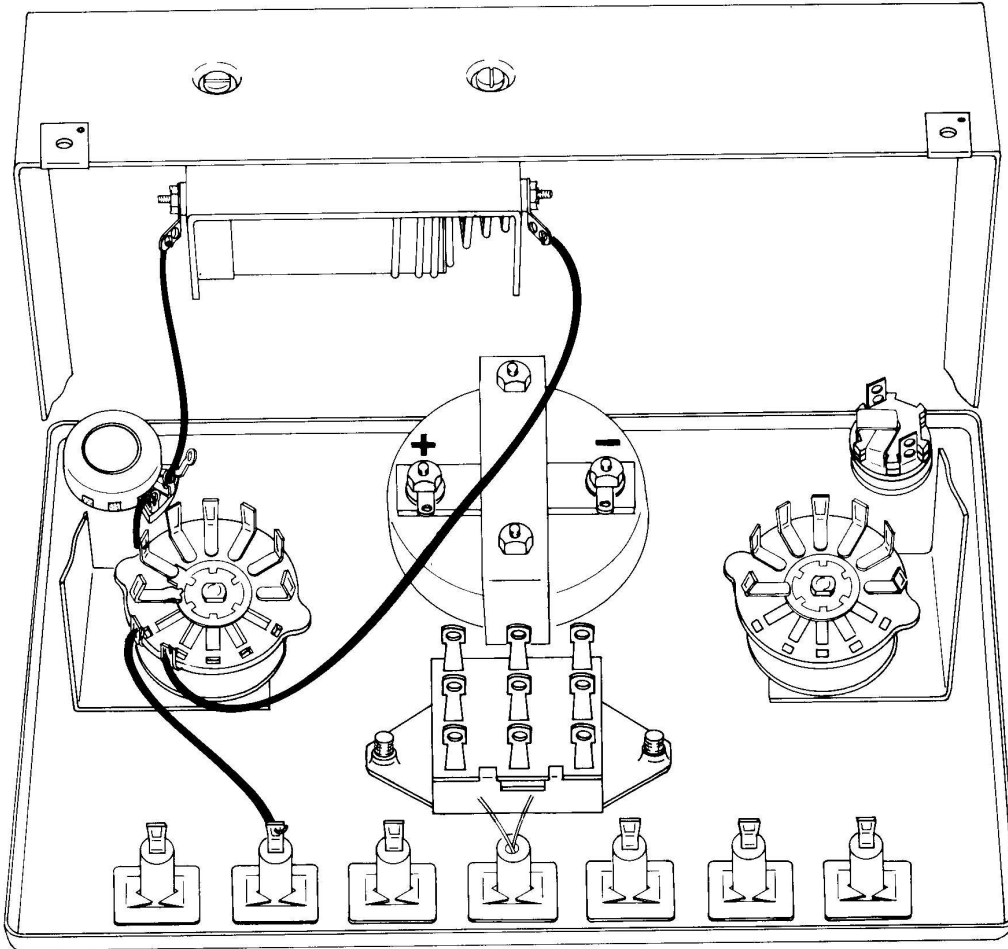

Figure 3-26A

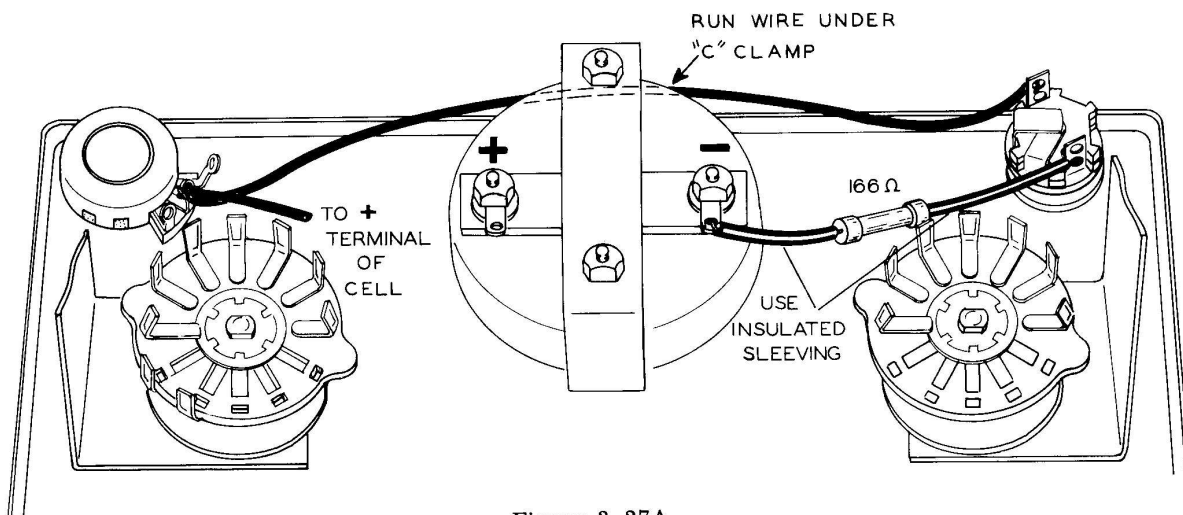

Figure 3-27A

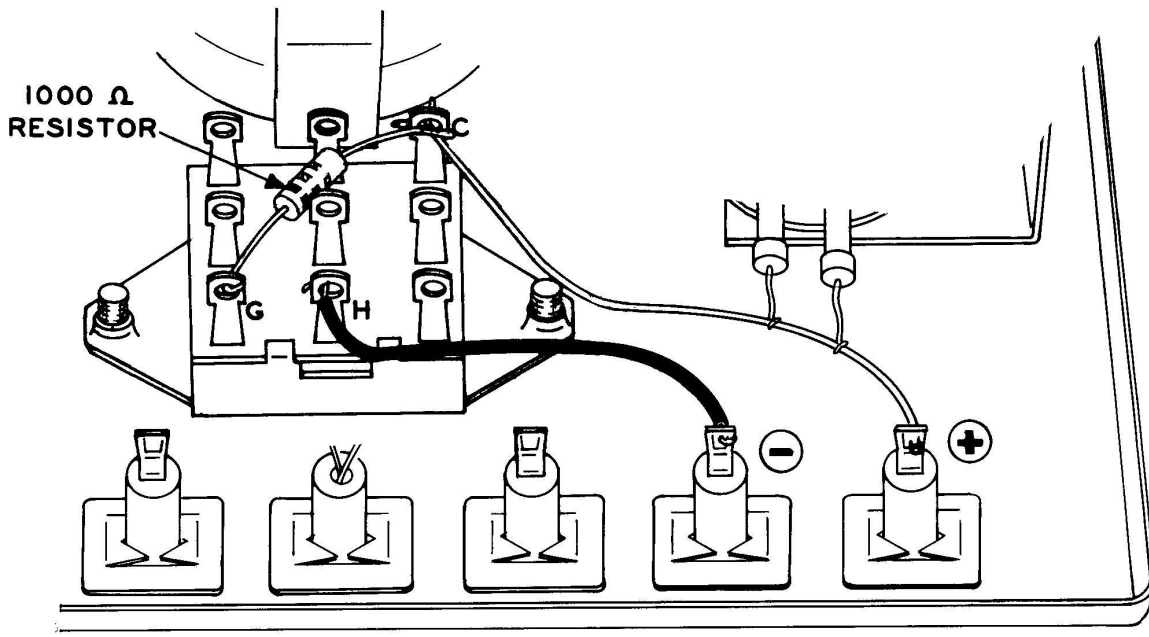

Figure 3-30A

SERVICE

In event continued operational difficulties of the completed instrument are experienced, the facilities of the Heath Company Service Department are at your disposal, or you may contact our Technical Consultation Department by mail. Local Service is available in some areas through authorized Heathkit Service Centers. You will be charged a minimal service fee, plus the price of any additional material or parts that may be required. THESE SERVICE POLICIES APPLY ONLY TO THE COMPLETED INSTRUMENT CONSTRUCTED IN ACCORDANCE WITH THE INSTRUCTIONS AS STATED IN THE MANUAL. Instruments that are not entirely completed or instruments that are modified in design will not be accepted for repair. Instruments showing evidence of acid core solder or paste fluxes will be returned NOT repaired.

REPLACEMENTS

Material supplied with Heathkits has been carefully selected to meet design requirements and ordinarily will fulfill its function without difficulty. Occasionally improper instrument operation can be traced to a faulty component. Should inspection reveal the necessity for replacement, write to the Heath Company and supply all of the following information:

- A. Thoroughly identify the part in question by using the part number and description found in the Manual Parts List.
- B. Identify the kit Model Number and Series Number.
- C. Mention date of purchase.
- D. Describe the nature of defect or reason for requesting replacement.

The Heath Company will promptly supply the necessary replacement. Please do not return the original component until specifically requested to do so. Do not dismantle the component in question as this will void the guarantee. This replacement policy does not cover the free replacement of parts that may have been broken or damaged through carelessness on the part of the kit builder.

SHIPPING INSTRUCTIONS

In the event that your Instrument must be returned for service, these instructions should be carefully followed.

ATTACH A TAG TO THE INSTRUMENT BEARING YOUR NAME, COMPLETE ADDRESS, INVOICE NUMBER ON WHICH THE INSTRUMENT WAS PURCHASED, AND A BRIEF DESCRIPTION OF THE DIFFICULTY ENCOUNTERED. Wrap the Instrument in heavy paper, exercising care to prevent damage. Place the wrapped Instrument in a stout carton of such size that at least three inches of shredded paper, excelsior, or other resilient packing material can be placed between all sides of the Instrument and the carton. Close and seal the carton with gummed paper tape, or alternately, tie securely with stout cord. Clearly print the address on the carton as follows:

To: HEATH COMPANY
Benton Harbor, Michigan 49023

Include your name and return address on the outside of the carton. Preferably affix one or more "Fragile" or "Handle With Care" labels to the carton, or otherwise so mark with a crayon of bright color. Ship by insured parcel post or prepaid express; note that a carrier cannot be held responsible for damage in transit, if in HIS OPINION, the article is inadequately packed for shipment. Your Instrument will be returned by express collect.

SPECIFICATION CHANGES

All prices are subject to change without notice. The Heath Company reserves the right to discontinue instruments and to change specifications at any time without incurring any obligation to incorporate new features in instruments previously sold.

WARRANTY

Heath Company warrants that all Heathkit parts shall be free of all defects in materials and workmanship under normal use and service, and in fulfillment of such warranty Heath Company will, for a period of three months from the date of shipment, replace any part upon verification that it is defective.

The foregoing warranty shall apply only to the original buyer, and is and shall be in lieu of all other warranties, whether express or implied and of all other obligations or liabilities on the part of Heath Company and in no event shall Heath Company be liable for any anticipated profits, consequential damages, loss of time or other losses incurred by the buyer in connection with the purchase, assembly or operation of Heathkits or components thereof. No replacement shall be made of parts damaged by the buyer in the course of handling or assembling Heathkit equipment.

The foregoing warranty is completely void if corrosive solder or fluxes have been used in wiring the equipment. Heath Company will not replace or repair any equipment in which corrosive solder or fluxes have been used.

This warranty applies only to Heath equipment sold and shipped within the continental United States including APO and FPO shipments. Warranty replacement for Heathkit equipment outside the United States is on an f.o.b. factory basis. Contact the Heathkit authorized distributor in your country or write: Heath Company, International Division, Benton Harbor, Michigan, U.S.A.

HEATH COMPANY



SPECIFICATIONS

D-C Voltmeter	
5 Ranges:.....	0-5, 10, 50, 100, 500 volts full scale.
D-C Milliammeter	
6 Ranges:.....	0-1, 5, 10, 50, 100, 500 milliamperes full scale.
Ohmmeter	
2 Ranges:.....	100 - 20,000 ohms (1500 ohms center scale). 10 - 2,000 ohms (150 ohms center scale).
Battery:.....	1 1/2 volt type "C" flashlight cell.
Meter:.....	2 1/4 " 1 ma, 1000 ohm internal resistance, 5% of full scale movement, clear plastic case.
Multipliers:.....	1% precision type.
Cabinet:.....	7 3/8" long x 4 11/16" high x 4 1/8" deep. Charcoal gray panel, feather gray cabinet.
Net Weight:.....	2 1/2 lbs.
Shipping Weight:.....	4 lbs.

INDEX

This index, of words or terms used in electricity, indicates the page in which the word or term is first used or defined.

- AMPERE, 9
- ATOMS, 1
- CALIBRATING, 32
- CELL, DRY and WET, 6
- CHARGE, 1
- CONDUCTORS, 11
- CONTINUITY, 101
- COULOMB, 9
- DIRECT CURRENT, 6
- ELECTRIC CURRENT, 9
- ELECTRIC FORCES, 1
- ELECTRIC LAMP, 8
- ELECTRICITY, 1
- ELECTRODE, 6
- ELECTRONS, 1
- FUSE, 12
- FUSE BOX, 12
- INSULATORS, 12
- MAGNETIC FIELD, 26
- NEGATIVE ELECTRICITY, 1
- NEUTRON, 1
- OHM, 29
- OHM'S LAW, 39
 - Three forms of, 44
- PARALLEL CIRCUIT, 13
- POWER, ELECTRICAL, 95
 - Maximum, 96
- PROTONS, 1
- RATE, TIME RATE, 10
- RESISTANCE, 29
 - Internal, 97
- RESISTOR, 29
 - Multiplier, 65
- SCHEMATIC DIAGRAM, 8
- SERIES CIRCUIT, 6
- SHORT CIRCUITING, 4
- SHUNT, 13
- SWITCH, 4
 - Rotary shorting and non-shorting type, 23
- TERMINAL, NEGATIVE and POSITIVE, 6
- VOLT, 7
- VOLTMETER, 59
- WATT, 95

NOTES

PP 85

HEATH COMPANY

THE WORLD'S FINEST ELECTRONIC EQUIPMENT IN KIT FORM

BENTON HARBOR, MICHIGAN

Made in U.S.A.